

Series 2
BOX 1
CF 21

NASA Manned Spacecraft Center
Houston, Texas 77058
October 4, 1967

APOLLO GUIDANCE SOFTWARE
DEVELOPMENT AND VERIFICATION PLAN

43 pages

Prepared by
THE GUIDANCE SOFTWARE VALIDATION COMMITTEE

- R. E. Wilson EG42/Guidance and Control Division
- Dr. M. Kayton EG43/Guidance and Control Division
- D. W. Gilbert EG27/Guidance and Control Division
- Dr. K. J. Cox EG23/Guidance and Control Division
- S. P. Mann FM7/Mission Planning and Analysis Division
- J. E. Williams FS55/Flight Support Division
- R. V. Sperry Bellcomm
- E. Copps MIT/IL

for
THE GUIDANCE SOFTWARE CONTROL PANEL

**WSU SPECIAL COLLECTIONS
FOR RESEARCH USE ONLY**

Approval: *Harold Cohen*
Chairman
Apollo Guidance Software Control Panel

CONTENTS

	<u>PAGE</u>
1. Purpose and Scope	1-1
2. Summary and Conclusions	2-1
3. Software Development	3-1
3.1 Source Data	3-1
3.2 Software Design Specification	3-1
3.3 Program Development and Development Testing	3-3
3.3.1 Equations Development and Analysis	3-3
3.3.2 Program Development and Integration	3-3
3.3.3 Qualification	3-4
4. Software Verification Procedures	4-1
4.1 Verification Test Planning	4-1
4.2 Verification Facilities Preparation	4-4
4.3 Verification Testing	4-5
4.4 Verification Test Results Documentation	4-5
5. Software Verification Testing	5-1
5.1 Engineering Simulators	5-1
5.2 Interpretive Computer Simulations (ICS)	5-2
5.3 Hybrid Simulators	5-3
5.4 Associated Tests	5-4
5.4.1 System Intogration Tests	5-4
5.4.2 Astronaut Procedure Tests	5-5
5.5 Flight Fixed and Erasable Memory Verification	5-6
5.5.1 Flight Fixed Memory Certification	5-6
5.5.2 Erasable Load and Tape Generation	5-6
6. Simulation Model Control	6-1
6.1 Simulation Master Model	6-1
6.2 Simulation Facility Models	6-2

	<u>PAGE</u>
7. Software Review, Approval and Control	7-1
7.1 Configuration Management	7-1
7.1.1 Software Approval Procedures	7-1
7.1.2 Software Change Control Procedures	7-5
7.2 Software Design Specification Review	7-6
7.2.1 Preliminary Design Review (PDR)	7-6
7.2.2 Critical Design Review (CDR)	7-6
7.3 Development Testing Reviews	7-6
7.3.1 Development Test Plan Reviews	7-6
7.3.2 First Article Configuration Inspection	7-7
7.4 Customer Acceptance Readiness Review (CARR)	7-7
7.5 Flight Readiness Review (FRR)	7-7
8. Schedules	8-1
8.1 Apollo Guidance Computer Software Schedule	8-1
8.1.1 Critical Design Review (CDR)	8-1
8.1.2 Test Plan Review (TPR)	8-1
8.1.3 First Article Configuration Inspection	8-1
8.1.4 Customer Acceptance Readiness Review	8-2
8.1.5 Flight Readiness Review (FRR)	8-2
8.2 ACS Software Schedule	8-2
8.2.1 Critical Design Review (CDR)	8-2
8.2.2 First Article Configuration Inspection	8-2
8.2.3 Customer Acceptance Readiness Review	8-3
8.2.4 Flight Readiness Review (FRR)	8-3

1. PURPOSE AND SCOPE

This report documents the general plan for verification of the Apollo flight software. The plan defines the necessary steps for control and verification of the software to be contained in the Command Module Computer (CMC), LM Guidance Computer (LGC), and the computer in the LM Abort Guidance Section (AGS). Included in this plan are the software development; software verification; simulation model control; software review, approval, and change control; and representative schedules. The general plan is summarized, and conclusions and recommendations are presented in Section 2.

The scope of this plan is limited to the existing Apollo software procedures and status. The AGS software procedures differ from those for the CMC and LGC in a minor respect but this plan is general enough so that it applies to all three Apollo software development efforts. Specific differences between the AGS software development and the CMC and LCC software development will be noted only when it is deemed necessary for clarification.

Software, as defined in this report, means only the contents of the computer which is more normally called the computer program. In the context of this report, qualification means that it has been demonstrated by the contractor that the software meets the requirements set forth in the specifications and verification means that it has been demonstrated independent of the software contractor that the software meets the requirements set forth in the specifications. Software development is included in this plan to identify the development procedures necessary for delivery and Verification of a program.

2. SUMMARY AND CONCLUSIONS

The recommended software development and verification procedures are given in Figure 2-1. Tests, reviews, and approvals are shown for three software phases: the definition phase, the development phase, and the verification phase.

Identified in the definition phase are the definition of requirements, the generation of the specifications and equations, and engineering simulation testing of these equations. The testing to be accomplished by MSC and by the software contractor leads to the approval (by the responsible MSC divisions) of the specifications and equations. The formal approval by the MSC Guidance Software Control Panel takes place at the Critical Design Review (CDR). This approval places the software definition documentation under configuration control. The CDR formally starts the software developmental phase.

In the development phase the computer programs are developed and tested, and the verification and qualification test plans are written and reviewed. Reviews are held throughout this phase whenever significant test plans and results are produced. The formal approval of the satisfactory completion of development testing occurs at the First Article Configuration Inspection (FACI). The software is placed under configuration control at the FACI. This review starts the formal software qualification and verification phase.

A formal qualification test plan and an independent verification test plan will be prepared for approval at the FACI. Upon satisfactory completion

of the qualification tests, the software is formally approved and accepted at the Customer Acceptance Readiness Review (CARR). Preliminary results available from the independent verification tests are also reviewed prior to the CARR.

The software, accepted at the CARR, is then released for hard memory fabrication, verification, and system testing at KSC. The hard memory fabrication will be consistent with the need date at KSC. Following the CARR, erasable memory tapes are generated and verified; the final version of the specification, equations document, and flow diagrams of the accepted software are published, and the verification testing is completed. These activities will be reviewed and approved at the final software review prior to the Flight Readiness Review (FRR). Certification of the software for flight is given at the FRR.

For subsequent flights, where some changes are to be made in the fixed memory, the above cycle is repeated with the testing reduced in accordance with the magnitude of the change. If, at the CDR, the fixed memory from a previous flight is approved for a subsequent flight, the cycle is reduced, and only flight peculiar testing and the software generation and verification activities, shown after the CARR in Figure 2-1 are necessary. These procedures are particularly applicable to the AGS.

The following items are identified as improvements, changes, or additions required in existing Apollo software procedures.

- a. A complete software specification, including a set of crew procedures consistent with program design and interface definition,

must be included in the software documentation as approved at the CDR.

- b. The responsible MSC divisions must insure that sufficient engineering tests are accomplished and reviewed to enable them to actively approve the software specifications and equations at the CDR and to provide their required inputs to software test planning.
- c. A master model of the spacecrafts, environment and interpretive computer simulators must be developed and controlled for simulator design and verification functions. The models at each facility used in software simulations must be consistent with the master model, documented, and actively approved.
- d. Associated tests such as systems integration, simulated flight, and crew procedure tests although not a part of formal in-line software verification do provide important additional testing and any anomalies effecting software must be reported to the Guidance Software Control Panel.
- e. The responsible MSC divisions must verify that crew procedures, operational targeting, and real time mission targeting are consistent with the software.
- f. Configuration control of applicable mission program functions, as determined by MSC, must be maintained from mission to mission. This includes changes to any instruction or constant related to the peculiar function.
- g. Special emphasis must be placed in defining performance design requirements.

h. The Software Design Specification (SDS) must be presented at the FACI in preliminary form for review and for final review at the CARR. Publication of this document will be within one month of the CARR.

3. SOFTWARE DEVELOPMENT

Independent verification of a computer program requires ample time following program coding to thoroughly test the performance. In Apollo, as in most real situations, efficiency and economy of verification demand that the program development be controlled and documented in accordance with the needs of testing as well as those of programming. Therefore, it is necessary to identify the program development procedures, consistent with present Apollo software philosophy, which are necessary for delivery of a program that can be verified in the time available.

3.1 SOURCE DATA

Flight program development requires data sources that explicitly define the constraints and requirements. The data sources employed are the guidance computer software requirements, mission requirements, hardware specifications, interface control documents, and data exchange documentation. Those sources provide the basis for the generation of the Software Design Specifications (for the primary systems, the Guidance System Operations Plan, and for the Abort, Guidance System, a series of design reports). The Software Design Specification (SDS) is a configuration controlled document and requires MSC approval for any modifications due to changes or additions in the source data.

3.2 SOFTWAREDESIGN SPECIFICATION

The key to successful development of flight software is its specification. The contents of the SDS will be discussed in this section.

The SDS should contain all requirements for program modes, functions, interfaces, the equations and logic to be programed to satisfy the requirements, and an operations manual for exercising the program to satisfy the requirements. The SDS should specify kinds of displays, their units, and number of digits. When the SDS is drafted by the software contractor, it is to be distributed to all concerned divisions of MSC. The divisions are responsible for the review of the SDS and for the verification that the program, designed to satisfy the requirements and constraints of the SDS and implemented through the equations contained in it, will satisfy their needs. The SDS will include all pertinent data on constants including their scaling and units along with range of validity of constants. In addition, the accuracy of computation is required. The end product of the review will be formal signoff of the SDS at the divisional level of MSC. The SDS becomes a configuration controlled document as described in Section 7 of this report. The review process employed must include study of the equations testing performed at the contractor's facility and any additional engineering studies deemed necessary by the division to confirm performance.

Following program configuration control, the preparation of the final SDS begins. This document will update the approved version with only changes approved since the earlier document underwent configuration control. A complete set of flow charts consistent with the flight program and a program listing must be included, along with definitions of program variables and constants, so that the final document represents a full definition, in standard engineering language, of the contents of the flight program and the mechanism for its use, including the constraints and requirements to which it has been designed.

3.3 PROGRAM DEVELOPMENT AND DEVELOPMENT TESTING

The development and testing of a flight program by the software contractor covers three phases of work: (1) the equations development and analysis phase, (2) the program development and integration phase, and (3) the qualification phase.

The following descriptions of testing performed during these three phases are the minimum allowable requirements for testing. A software contractor has the option to breakdown the testing to further sub-levels within a given phase but each new level defined must be reviewed and approved by MSC. Positive control procedures will be exercised through configuration control of test plans subsequent to approval of the SDS at the CDR.

3.3.1 Equations Development and Analysis

This phase covers the development and analysis of the equations necessary to meet the software requirements. This testing must be documented and reviewed at the CDR prior to approving the SDS.

3.3.2 Program Development and Integration

During this phase the major programs with their supporting routines and subroutines are coded and tested on an individual basis. Following satisfactory completion of this testing the program elements are integrated together and tested in sequence to insure satisfactory performance through the various mission phases. Test plans for this phase will be reviewed and approved by MSC. The results will be documented, reviewed, and approved by MSC prior to placing the program under configuration control,

3.3.3 Qualification

This **phase** qualifies the program for delivery by the contractor. The qualification test plan **is** generated by the contractor during the period of program development. The qualification test plan is reviewed formally and approved by **MSC** to insure its testing of all mandatory mission functions. The results **will** be documented, reviewed, and approved at the CARR prior to program release. **All** tests must be performed on the assembly of the program to be flown and must be executed in accordance with procedures defined in the **operations** manual.

4. SOFTWARE VERIFICATION PROCEDURES

This section describes the procedures used to verify that the Apollo guidance software represented by the final **released** flight program meets the software requirements defined **by** the specification. The verification is accomplished by testing the flight program independent of, but closely coordinated with, the testing performed by the software contractor. The flight program is verified against the requirements defined by the SDS for both a range of missions and also for any specific **missions** that may be defined. The testing is performed by engineering simulations, bit-by-bit simulations, and hybrid simulators. Those simulators and their applicability are described in Section 5.

The following phases of software verification are shown in the flow chart in Figure 4-1:

- Test requirements determination
Test planning
- Modification and validation of simulators
- Test analysis and results **summary**

4.1 VERIFICATION TEST PLANNING

Test requirements in verification testing are established by the following inputs:

- Program specification, equations, and operating procedures
- Reference trajectories
- Flight plans defining guidance programs' utilization
- Test requirements (including evaluation criteria) defined by responsible MSC divisions
- Equation performance data obtained from engineering simulation results

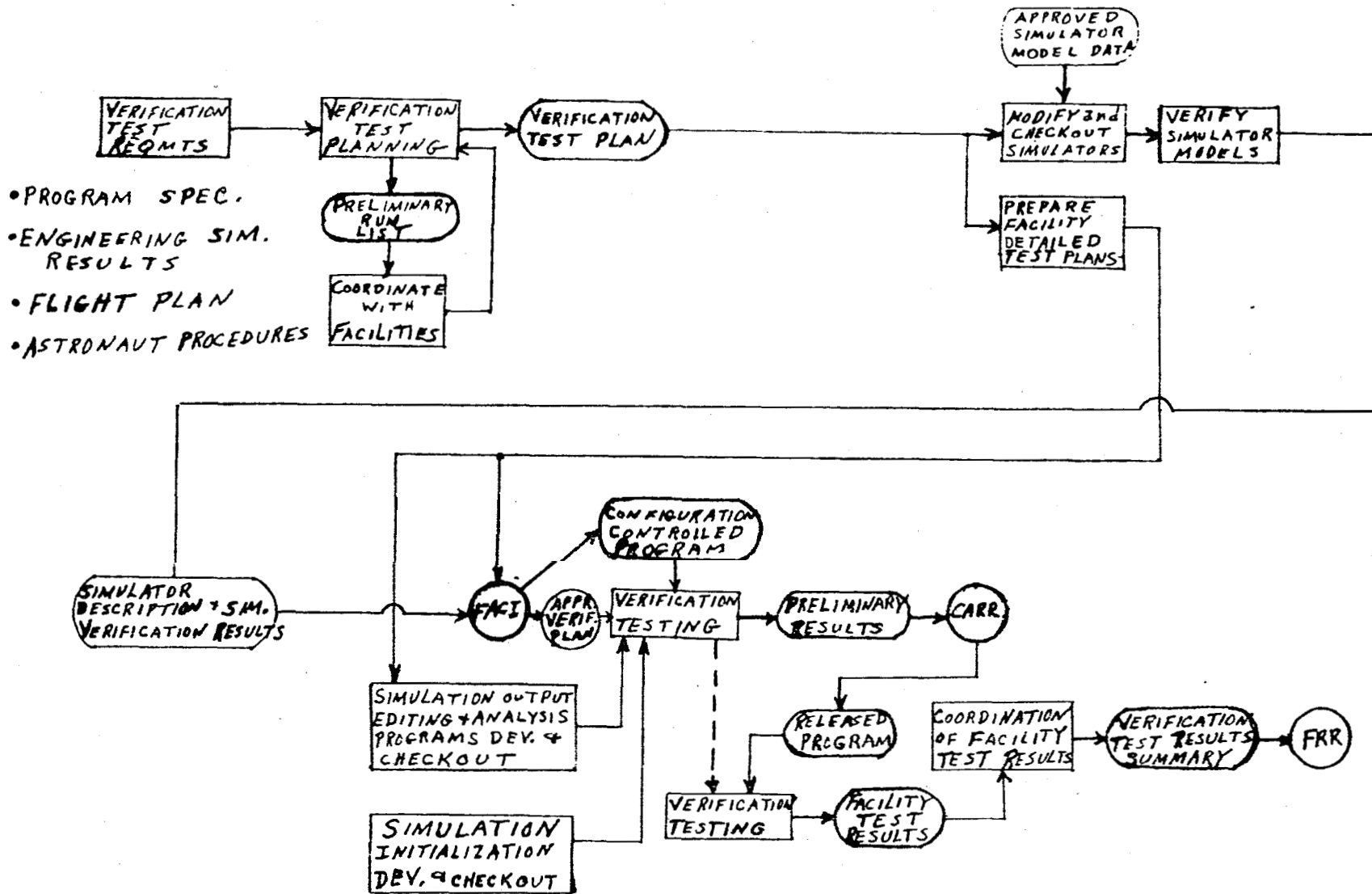

FIG. 4-1 SOFTWARE VERIFICATION PROCEDURES

- Hardware and system dispersions defined in the simulation master model
- Test requirements for marginal testing

The test planning phase begins with MC generating a preliminary list of the tests planned for each facility. This list is coordinated with the simulation facilities that will perform the tests. Each facility will prepare test plans defining in detail the following information on the runs to be performed:

- Run description
- Objective
- Simulation interval
- Flight program sequencing
- Flight program routines exercised
- Run evaluation criteria
- Simulation initial conditions
- Simulation output requirements
- Astronaut or uplink procedures
- Run priority

A master plan which defined all independent verification testing to be performed on the flight program is then developed based on the coordinated list. An outline of the contents of the test plan is given in Table 4-1. This test plan contains references to all documentation defining requirements for testing and simulation. A discussion of the testing includes a summary of the testing planned, reference to previous testing that is applicable, a definition of the areas of testing not included, and a comparison with the qualification testing planned by the software contractor. Ground rules for testing priority will also be established,

The core of the verification test plan is the test specifications that define the test, output requirements, and evaluation criteria. A separate specification is prepared for each test providing the information shown in the outline. The test plan documentation includes test procedures and test results prepared by each facility performing the tests.

The verification test plan will be formally reviewed and approved by the Guidance Software Control Panel at the FACI. The review and approval of the software contractor qualification test plan will be held at the same time.

4.2 VERIFICATION FACILITIES PREPARATION

The first step in verification testing is to modify, checkout, and validate the simulation facilities to be used. This procedure will be based upon approved simulation model data defined by the simulation master model (Section 6). A document describing the simulation models and containing the results of the validation of the simulation models will be prepared and submitted for review by each simulation facility.

Verification test preparation will also include development or modification of simulation output editing and analysis programs. Initialization of the simulation runs includes initialization of the flight program and the simulation of the environment external to the flight program. A review of the facility test plans and of the facility simulation description documents will then be held to insure compatibility with the requirements of the master verification test plan and master simulation model. Subsequent to validation of the simulator models and prior to start of formal testing, the simulators will undergo configuration control.

4.3 VERIFICATION TESTING

Formal verification testing and software contractor qualification testing **will** begin at the time the flight program undergoes configuration control. The verification testing, unlike the qualification testing, will continue after release is approved at the Customer Acceptance Readiness Review (CARR).

Subsequent to program release, the remainder of the verification testing is performed on the released flight program. Any changes to the flight program after configuration control are considered for their impact on the verification testing as well as on the qualification testing.

Flight program anomalies encountered during verification testing are reported promptly via discrepancy reports prepared by the testing facilities, and are investigated thoroughly. The cause and resolution of the problems are recorded by the GSCP.

For verification purposes, a standard erasable load **will be** defined at the CARR.

4.4 VERIFICATION TEST RESULTS DOCUMENTATION

At completion of the testing, a summary and analysis of test results is prepared by each simulation facility. The format of the test results document is specified in the master verification test plan. The test results documents will identify whether tests have passed or failed evaluation criteria. Exceptions or anomalies noted during the testing **will** be noted and workaround procedures, as applicable, **will** be identified.

The individual test results documents will be coordinated and reviewed and an overall verification test results summary will be presented to the Guidance Software Control Panel prior to the Flight Readiness Review. This review certifies that the program is properly verified and ready for flight.

TABLE 4-1. OUTLINE MASTER TEST PLAN

1. Purpose and Scope
2. Applicable Documentation
 - Software Design Specification
 - Mission Definitions
 - Data Specifications
 - Flight Program Performance Requirements and Constraints
 - Simulator Capabilities Documents
3. Discussion of Testing
 - Summary of Testing for each Simulator
 - Comparison with Software Contractor Testing
 - Previous Testing that **is** Applicable
 - Areas of Tasting not Included
 - Testing Priority
4. Test Specifications
 - Run Description
 - Objective
 - Simulation Interval
 - Flight Program Sequencing
 - Routines Exercised
 - Test Evaluation Criteria
 - Output Requirements
 - Facility Used
 - Test Priority
5. Documentation and Schedule
 - Schedule of Testing and Documentation
 - Definition of Contents and Format of Documents

5. SOFTWARE VERIFICATION TESTING

Software verification is accomplished by employing flight software simulations to obtain the data needed to meet the verification test requirements. The three types of simulators required are: (1) engineering simulators, (2) hybrid simulators, and (3) interpretive computer simulations. A description of the simulators required for verification, and associated tests that support the verification process are specified in this section. The procedures to be followed in the verification and control of the hardware memory ropes and erasable memory tapes are also described in this section.

5.1 ENGINEERING SIMULATORS

Engineering simulators duplicate software equations but are independent of the characteristics of the real computer. They cover a broad range of possibilities from a simple open loop simulation of one set of equations to a full mission closed loop simulation and are extensively used in equation and trajectory design and in software verification. These simulations have the advantage of being completed early in the software development cycle, following the equations definition. They are suitable for broad parametric studies to determine the realm of acceptability of the equations.

A well designed engineering simulator can determine if the equations are satisfactory, but normally this does not mean the flight software can perform as well as the simulations indicate. The flight computer is more restrictive than the scientific computers.

In the software definition and development phase, sufficient engineering simulations studies should be accomplished to verify that the equations to be programed, as given the SDS, can meet the software requirements.

These engineering simulators will be used to support the verification of the actual software, to generate test cases to compare the results of ICS and hybrid simulations, and to provide initialization data needed to set up the runs on the other simulators.

5.2 INTERPRETIVE COMPUTER SIMULATIONS (ICS)

Interpretive computer simulators are all digital programs that are exact logical representations of the flight computer. They simulate the flight computer on a scientific digital computer and execute the flight programs without modification on the simulating computer. They are used in conjunction with Flight Simulators (FS) which are mathematical models of the spacecraft dynamics and environments that interface with the flight computer. The ICS can be used to examine the contents of registers and instructions at all or selected steps of flight program execution. These simulators are the only available tool for this microscopic analysis of the software operation.

In combination with Flight Simulator, a complete mission or any part of the mission, can be simulated and the output and internal operation of the software checked.

The ICS-FS will be used to verify that the software satisfies the approved requirements for the nominal mission and for selected perturbations. The issuance of all discrettes and other outputs will be checked

for proper timing, polarity as defined by specification, magnitude, and frequency, including all specified levels of reaction. All failures the computer is to monitor will be induced to cause the computer to take alternate actions.

Any known or suspected software anomalies will be investigated, microscopically, on the ICS-FS by employing the ICS features of program trace, illegal instruction detection, overflow detection, etc.

In order to achieve the capability to microscopically examine the action of the simulated computer, the ICS-FS is usually slower than real time. Therefore, it may be more economical to employ other test facilities that operate in real time for those verification tests that require several runs to determine the effect of parameter variations and where detailed knowledge of the computer operation is not needed.

5.3 HYBRID SIMULATORS

In this report a hybrid simulator refers to a simulation that contains a real flight computer and operates in real time. It is a flight simulator composed of general purpose analog and digital computers, guidance and control subsystem hardware, special purpose hardware and interface equipment, and a crew station mockup with appropriate displays and controls. The hybrid simulators have the capability to verify the hardware-hardware and hardware-software functional interfaces as well as the overall G&C equipment compatibility with crew procedures, visibility, and mission time line. They will be used in the software development and qualification testing and as part of the independent verification testing. Specifically,

there shall be a hybrid simulation of the primary G&C active phases of each mission with MSC flight crews conducted at the software contractors facility as part of the testing that must be completed before the software is put under configuration control. Subsequent to this there will be an independent hybrid simulation of all the G&C functions for each mission as part of the verification activity for each mission. This verification activity will be a constraint; to rope manufacture.

5.4 ASSOCIATED TESTS

In the overall Apollo testing there are a number of test sequences that employ the flight software and these tests should be reviewed as part of the software verification activity.

The integration of the G&N system and the AGS, including the software, into the CSM and LM, are accomplished at the spacecraft contractor's facilities. These tests are accomplished with hybrid simulators and with the actual spacecraft.

5.4.1 System Integration Tests

At the Kennedy Space Center (KSC) the spacecraft with the G&N system is subjected to multiple tests. Included are vacuum chamber tests and a series of simulated flight tests. These tests officially verify the interface between the software and the spacecraft. A broad series of tests are performed, most of which *exercise* the software to some degree. The software will have been extensively verified prior to this time. This will, however, be the first mating of the software with the actual ACE equipment. The plans for these tests are reviewed and additions and

changes to the plan are recommended. Any anomalies that appear during the tests which could be a software problem **will** be reported to the Guidance Software Control Panel and detailed investigation of the anomaly will then be assigned to the appropriate verification facility.

5.4.2 Astronaut Procedure Tests

During the software development cycle the crew procedures **will** be defined and included in the software specification. These specified procedures **will** be verified on the ICS-FS and hybrid simulations. In addition, there **will** be testing of crew procedures in the mission simulators at MSC and KSC. These simulators do not contain a real computer but have an ICS. There **will** be a great deal of study of procedures on these simulators, and the results can be expected to provide data useful in extending and adding confidence to the in-line verification effort. This also holds for other astronaut procedure tests to be performed at MIT, NAA, and GAEC. The abbreviated crew check list must be reviewed by the GSCP and recommendations **made** to insure that it is consistent with the specification procedures. This check list should serve as the nominal set of crew procedures in verification. A series of tests are performed to insure compatibility between the RTCC targeting and the onboard flight program. The ICS-FS and hybrid simulators *are* used during this testing and the data provided *is* a significant part of the verification of the flight program. Astronaut procedures at NAA and GAEC must be **part** of the verification for manned software. Discrepancy reports **will** be provided for all anomalies found during manned testing.

5.5 FLIGHT FIXED AND ERASABLE MEMORY VERIFICATION

The verification effort discussed previously leads to verification of the flight fixed memory, using a nominal set of erasable memory constants, *so* that the flight fixed memory can be manufactured. The software verification also included the certification of flight fixed memory and the generation and verification of the tapes to be used to load the erasable memory. The flow diagram of the production and verification of flight fixed memory and those tapes is shown in Figure 5.1 and 5.2,

5.5.1 ~~Flight Fixed Memory Certification~~

Once the contents of the flight fixed memory are approved, procedures are followed to insure that the approved program, delivered by the software contractor, is identical, bit for bit, to the manufactured flight fixed memory. There ~~will~~ be a formal acceptance and certification of the flight fixed memory by MSC. At the acceptance tests, the contents of the manufactured flight fixed memory must **be** compared with the ~~MSC~~ approved configuration of the flight fixed memory software.

5.5.2 ~~Erasable Load and Tape Generation~~

The values of the constants to be used for the erasable load ~~will~~ be generated by MSC divisions and the software Contractor, and ~~the~~ verification will **be** performed by ~~MSC~~ and/or the software contractor. Review and approval by the GSCP is required prior to releasing the erasable load for manufacturing the tapes. These tapes will be used at KSC for loading the computer memory,

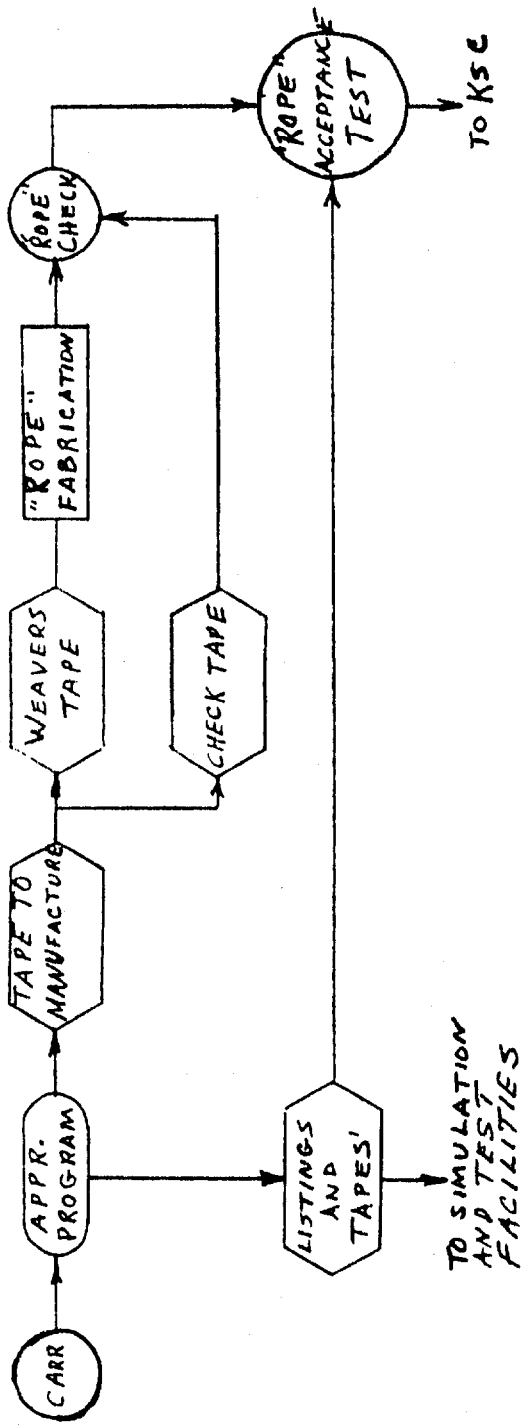

FIG. 5-1 FLIGHT FIXED MEMORY GENERATION & VERIFICATION

"ROPE" FLIGHT FIXED MEMORY

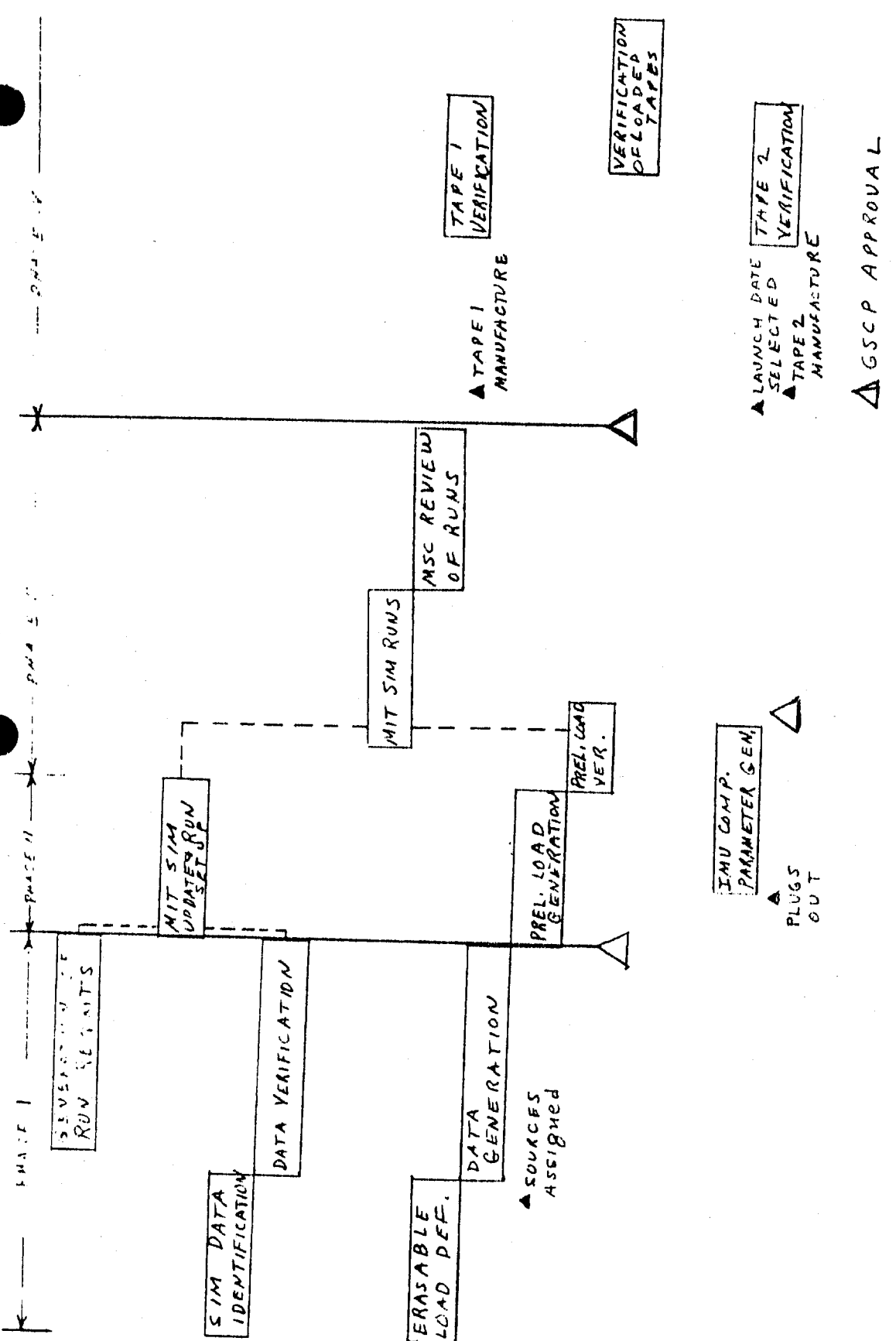

FIG 5-2 ERASABLE LOAD GENERATION AND VERIFICATION

6. SIMULATION MODEL CONTROL

The flight programs are developed and tested against models of the guidance and vehicle hardware. These require control to insure software fidelity to the physical environment, and consistency from one model to another. To this end, separate activities may be defined to provide a master model with maximum fidelity and approved facility models adequate for the testing to be performed in line with program verification.

6.1 SIMULATION MASTER MODEL

A best available model of the spacecraft must be developed, documented, and maintained for simulator design and validation functions. For any spacecraft/mission combination, this model must be verified and approved by the responsible divisions of MSC. Qualification testing by the contractor and verification testing performed independently must be executed on a simulator validated against an approved, configuration-controlled master model. Preliminary models may be employed for development testing and engineering studies, but it is mandatory that the best available data be used in the software verification and qualification. A request for clarification of, or a change to, any element of the master model may be initiated by any division of MSC, testing facility, software or hardware contractor which may require it. The models incorporated should include tolerances where applicable.

It shall be the responsibility of the agency supplying the hardware to NASA to define the master model for that hardware and to **decide** on the necessity for changes. The supplying agency shall take the initiative to

review changes to their equipment for effect on the simulation master model and inform the MSC and designated using agencies when changes are required. Changes to a simulation master model will be evaluated by the Guidance Software Control Panel to determine the impact on validity of verification activity completed or in progress and the effect on cost and schedule to make a change in the facility models.

6.2 SIMULATION FACILITY MODELS

Each using agency shall determine the extent to which the various simulation master models are to be simulated in their facility. Prior to the performance of qualification or verification testing, each facility whose simulator is to be in line with the release of the flight program must submit for MSC review and approval a description of the simulation models employed and the results of the verification of the simulation models against the master model.

Any changes in math models subsequent to this must be reported to MSC for review and approval as they occur and the final configuration summarized with a report on the results of the verification simulations.

In cases where an interpretive computer system is being used instead of a hardware guidance computer a series of tests must be conducted on the ICS and a hardware computer and the results submitted with the facility models prior to the performance of the qualification or verification testing.

7. SOFTWARE REVIEW, APPROVAL, AND CONTROL

This section defines the MSC configuration management procedures used to control the development and verification of the Apollo flight software. Software approval procedures, change control procedures and reviews held during the software development and verification process are described. Configuration control of the Software Design Specification and of the flight program is defined.

The formal reviews described in this section are those that are nominally required. The GSCP may schedule additional formal reviews as deemed necessary,

7.1 CONFIGURATION MANAGEMENT

The responsibility for management of the Apollo flight software is defined within MSC. The responsible MSC organization is the source of information and provides direction to the software contractors as shown in Figure 7-1. Various MSC divisions are assigned the responsibility of reviewing and approving various aspects of the software development and verification. These divisions provide review and approval of the software and are the source of software requirements.

The Guidance Software Control Panel (GSCP) has the overall responsibility of providing official certification for flight of the flight software. This panel, made up of representatives of various MSC divisions, coordinates the activities of these divisions.

7.1.1 Software Approval Procedures

The responsible MSC divisions review and give active approval of software requirements, the Software Design Specification (SDS), software

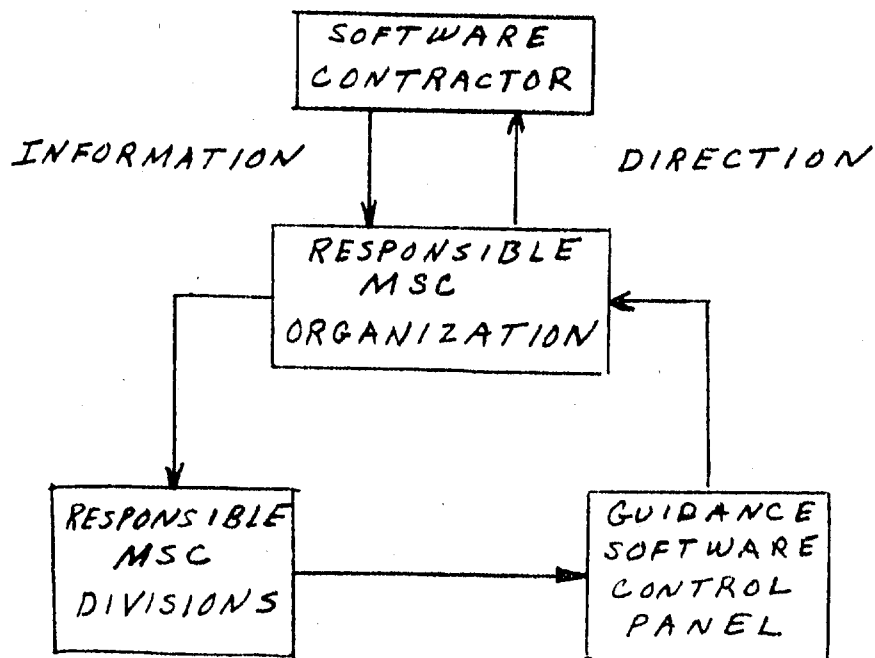

FIG. 7-1 SOFTWARE MANAGEMENT

test plans, and software test results. These reviews will include performing the necessary analyses and simulation studies to insure that software requirements have been adequately defined and that adequate testing, which demonstrates that the software meets the requirements, has been performed.

The Guidance Software Control Panel provides formal certification of the Apollo flight software. The areas of responsibility of the panel include the following:

- . Approve software requirements
- . Approve program specifications
- . Approve software test plans
- . Approve software changes
- . Approve adequacy of software testing
- . Certify flight readiness of Apollo flight software

Configuration control of the computer programs is exercised by controlling the SDS during the software development phase and the SDS and program listing during the software qualification and verification phases. Any change to the approved SDS must be approved by the GSCP using the change control procedures defined in Section 7.1.2. This includes changes to equations, constants, program design, operating procedures, and program interfaces.

Any change to the configuration controlled program after the FACT review must be approved by the GSCP, including changes to any memory call. Configuration control of applicable program functions, as determined by MSC, should be maintained from mission to mission. This includes changes to any instruction or constant related to the particular function.

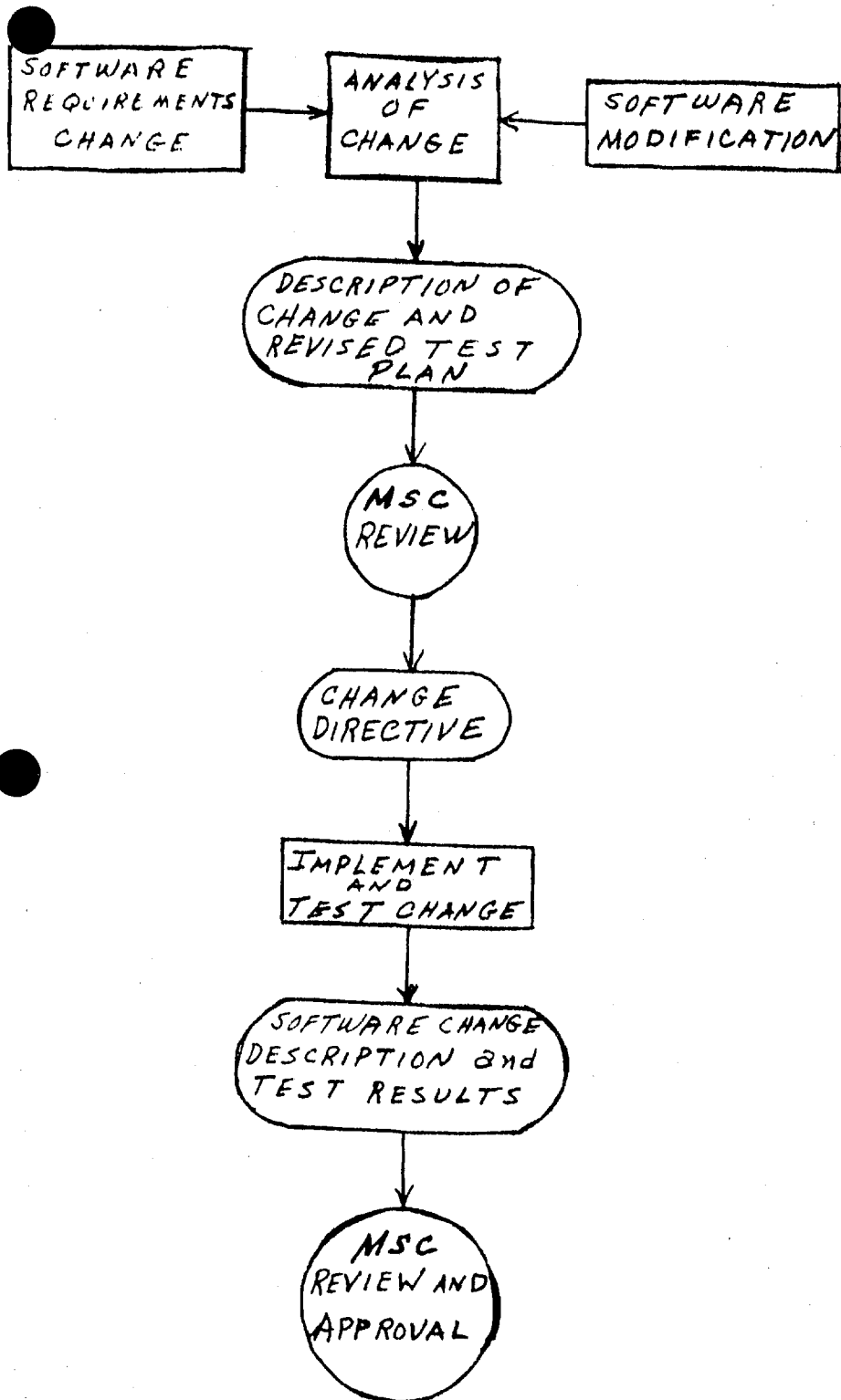

FIG. 7-2 SOFTWARE CHANGE PROCEDURE

7.1.2 Software Change Control Procedures

Procedures to control program changes are shown in Figure 7-2. These procedures are related to the overall software development and verification procedures. When a software change is initiated after the program and/or SDS have become configuration controlled, the steps of these change procedures are completed before returning to the normal procedures. The number of steps of the change procedures completed depends on the phase of the development and verification that the change is initiated, (Figure 7-2)

Software changes can be initiated by the software contractor or by MSC. The software change can be the result of requirement or software modification. After an analysis of the change by the software contractor, a description of the change, the impact of the change, and the testing required to evaluate the change is presented for MSC review. If the change is approved, a change directive is issued. The change is then implemented and tested by the software contractor, and the results are prepared in document form for MSC review and approval. Change to the SDS prior to the FACI will be reviewed at the FACI to insure proper implementation in the program. Any changes to the program, that takes place between the FACI and the CARR, will be reviewed at the CARR. Proposed changes to the flight program, subsequent to the CARR, should be reviewed by special sessions of the GSCP. The review should take into consideration all aspects of the mission (spacecraft schedules, methods of implementing, required testing, mission requirements, etc.) prior to recommending approval or disapproval.

7.2 SOFTWARE DESIGN SPECIFICATION REVIEW

7.2.1 Preliminary Design Review (PUR)

The PDR is joint MSC/contractor working group reviews of the preliminary SDS. The purpose of the PUR is to compare the contractor's design approach with the requirements specified by MSC. Results of engineering simulations by the contractor and organizations within MSC that demonstrate the performance of the equations in the SDS will be reviewed. Changes or action items to be accomplished by the contractor should be identified by the responsible MSC organizations and should be completed by the software contractor before approval of the SDS is given.

7.2.2 Critical Design Review (CDR)

The CDR is a formal review of the SDS by the GSCP. The divisional level of MSC and contractors are included in this review. The purpose of the CDR is to determine that adequate review and analysis have been performed to insure that the SDS satisfies the requirements provided by MSC. When the SDS is given formal written approval by MSC, it is published by the contractor with both the PDR and CDR comments incorporated and is placed under configuration control.

7.3 DEVELOPMENT TESTING REVIEWS

7.3.1 Development Test Plan Reviews

Working group reviews of software contractor development test plans are held by MSC. The purpose of these reviews is to insure that each step in the software development has been properly tested before proceeding to the next step. In addition, the reviews will also identify testing required to investigate known problem areas and provide coordination

of software contractor testing with applicable independent testing.

7.3.2 First Article Configuration Inspection (FACI)

The FACI is a working group review by M&C of (1) development test results, (2) qualification test plan, and (3) verification test plan. Review at the FACI will be directed towards assuring that the program reflects what is in the SDS and that the qualification and verification testing being planned are appropriate and complete. A review of flight program erasable load verification, rope memory generation, crew procedures, training plans, and prelaunch operations is also made. The outcome of the FACI is that the flight program undergoes configuration control and the qualification and verification test plans have been formally approved.

7.4 CUSTOMER ACCEPTANCE READINESS REVIEW (CARR)

The CARR is a formal review by the CSCP of the software contractor qualification test results and preliminary test results as available from independent verification.

The purpose of the CARR is to determine the readiness of the program for manufacturing release. If it is determined that the program has been properly qualified, it will be approved for release. However, if it is determined that the program is not ready for release, M&C will specify the action required on the part of the contractor to insure that the program is properly qualified.

7.5 FLIGHT READINESS REVIEW (FRR)

Prior to the FRR a formal review of all flight program verification test results will be held by the GSCP. The divisional level of M&C should

be included in this review. The purpose of this review is to determine the readiness of the software for flight. The results of flight program erasable load verification, rope memory generation ~~verification~~ and preluanch testing applicable to the software are also made. The result of the review is official certification by the GSCP at the FRR that the software is ready for flight.

8. SCHEDULES

The attached schedules (Figures 8-1 and 8-2) are representative of software development and verification sequences consistent with known requirements. Except as noted below, the sequence of events and required inputs and outputs for each review are unique.

8.1 APOLLO GUIDANCE COMPUTER SOFTWARE SCHEDULE

A representative schedule for the development and verification of the primary guidance system program is given in Figure 8-1. The constraining items in the detailed scheduling are the five reviews discussed below.

8.1.1 Critical Design Review (CDR)

The CDR reviews the GSOP and provides the mechanism for its formal approval. The complete draft submitted, no later than 6 weeks earlier, will have been reviewed and exhaustively tested in the interim; frequent preliminary design reviews will have been held to assist in the evolution of an acceptable document, but these are intended to be less formal meetings.

8.1.2 Test Plan Review (TPR)

With a baseline of the approved (controlled) GSOP, the contractor development test planning may be undertaken. The product of the TPR is the approved development plan. It should be noted that qualification test planning will be performed during the development phase and the plan will be reviewed and approved at the FACI.

8.1.3 First Article Configuration Inspection (FACI)

The primary output of the FACI is a flight program under configuration control. The necessary inputs to this review are the preliminary erasable memory load, the development test results, the qualification test plan, and the verification test plan. The review will include cognizant personnel from the MSC divisions and the contractors who have monitored the coding and testing during the period since the CDR.

8.1.4 Customer Acceptance Readiness Review (CARR)

The function of the CARR is to demonstrate to MSC, collectively, and to the GSCP, specifically, that the program is flightworthy. This is accomplished by means of a detailed review of the qualification test results and of the preliminary findings of the verification testing. The outputs of the CARR are the flight-release program, and the erasable memory load used for testing.

8.1.5 Flight Readiness Review (FRR)

The FRR is the end point for all system and subsystem qualification and verification; in the case of the software, this review provides the participants with the opportunity to certify the adequacy of the flight program testing through an examination of all test results.

8.2 ACS SOFTWARE SCHEDULE

A representative schedule for the development and verification of a particular ACS flight program is presented in Figure 8-2. The constraining items in the scheduling are the four design reviews discussed below.

8.2.1 Critical Design Review (CDR)

The CDR provides a review of the preliminary analysis of the requirements, a revised program specification, and a master development and qualification test plan.

8.2.2 First Article Configuration Inspection (FACI)

The inputs to the FACI review are development, test results, qualification test plan, and verification test plan. After this review, the flight program undergoes configuration control. The software contractor's qualification test plan and verification test plan are also reviewed and approved at this time,

8.2.3 Customer Acceptance Readiness Review (CARR)

The function of the CARR is to demonstrate to MSC, collectively, and to the GSCP, specifically, that the program is flightworthy. This is accomplished by means of a detailed review of the qualification test results and of the preliminary findings of the verification testing. The outputs of the CARR are the flight-release program, and the erasable memory load used for testing.

8.2.4 Flight Readiness Review (FRR)

The FRR is the final software review prior to the flight to review the results of the verification of all erasable memory tapes and ~~the~~ results of system integration testing.

EQ. DEV TEST | CODING AND DEVELOPMENT TESTING | QUAL. TESTING | DEVELOPMENT ACTIVITY

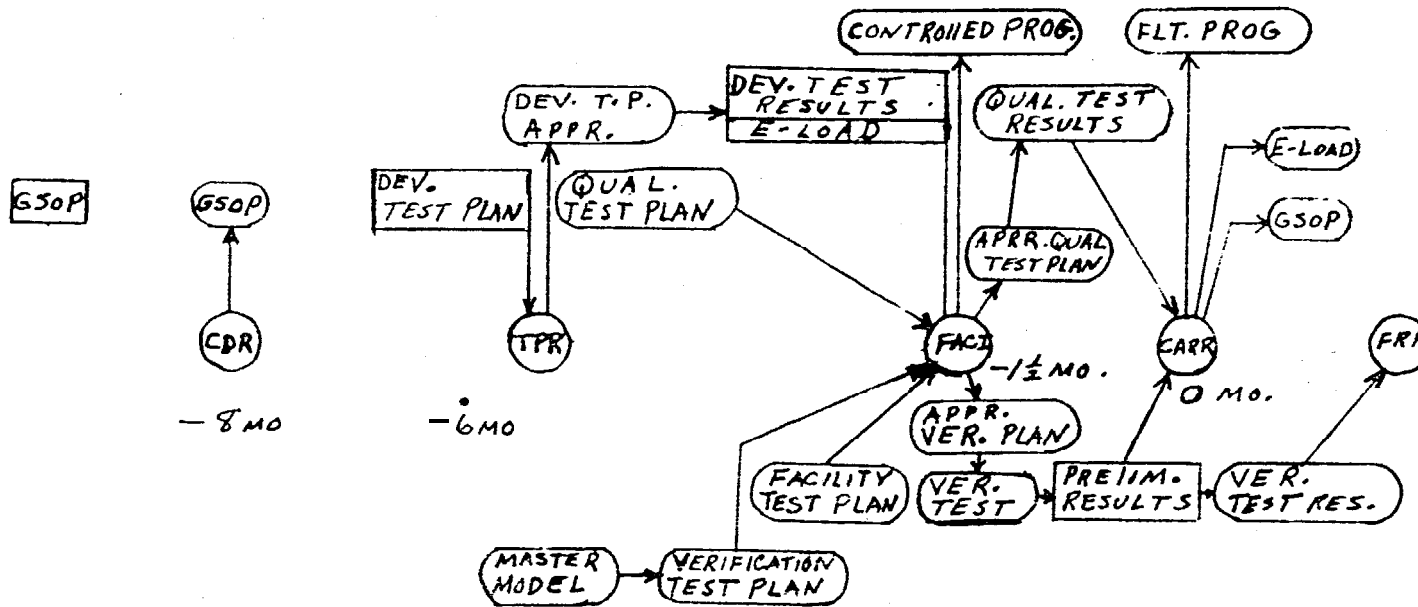

ENGR. TEST (EQUATION) | DEV. MONITOR, MODEL VERIFICATION, TEST INITIAL | VERIFICATION TESTING | VERIFICATION ACTIVITY

IZATION

FIG. 8-1 REPRESENTATIVE PGNC'S SOFTWARE DEVELOPMENT + VERIFICATION SCHEDULE

ANALYZE CHANGE PROGRAM MODIFICATIONS + CHECKOUT QUAL. TESTING

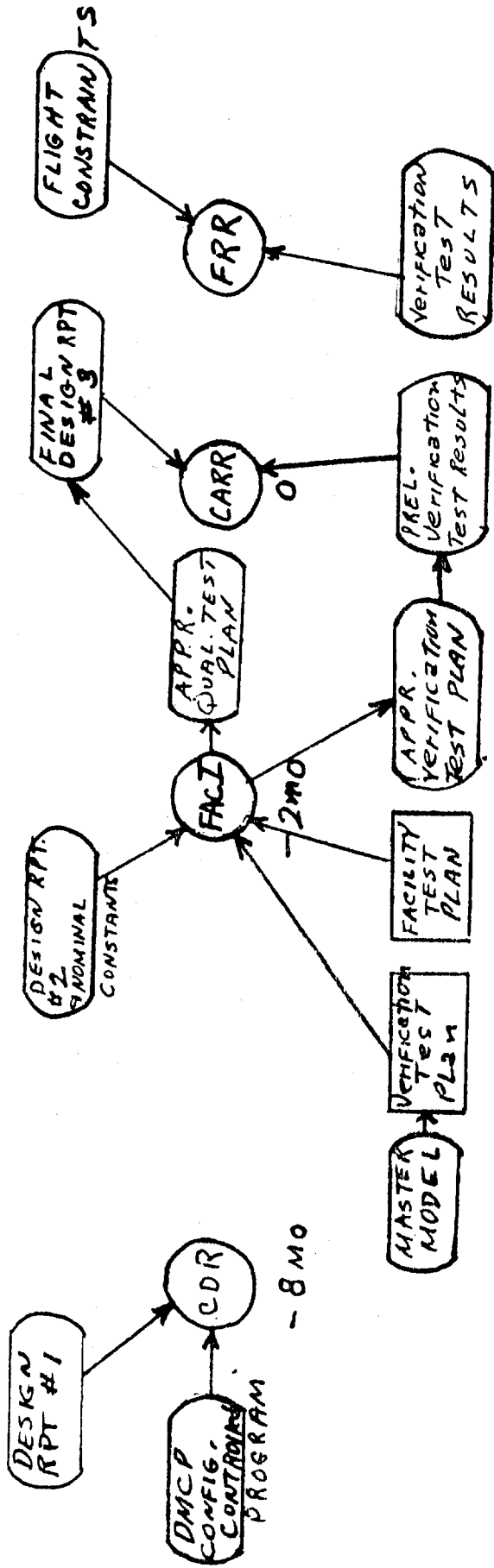

TEST PLANNING, SIMULATOR MODEL VER. VERIFICATION TESTING

FIG. 8-2 Representative AGS SOFTWARE DEVELOPMENT AND VERIFICATION SCHEDULE