

UNCLASSIFIED

Copy 3

FM 4-184

WAR DEPARTMENT

ANTI-AIRCRAFT ARTILLERY
FIELD MANUAL

BARRAGE BALLOON SITE
INSTALLATIONS

April 13, 1943

MHRC
COPY

REGRADED UNCLASSIFIED BY
AUTHORITY OF DOD DIR. 5200.1 R
BY TRAKERS ON 140205

FM 4-184

**ANTIAIRCRAFT ARTILLERY
FIELD MANUAL**



**BARRAGE BALLOON SITE
INSTALLATIONS**



UNITED STATES
GOVERNMENT PRINTING OFFICE
WASHINGTON : 1943

WAR DEPARTMENT,
WASHINGTON, April 13, 1943.

FM 4-184, Antiaircraft Artillery Field Manual, Barrage Balloon Site Installations, is published for the information and guidance of all concerned.

[A. G. 062.11 (2-25-43).]

BY ORDER OF THE SECRETARY OF WAR:

G. C. MARSHALL,
Chief of Staff.

OFFICIAL:

J. A. ULIO,
Major General,
The Adjutant General.

DISTRIBUTION:

IBn and H 44 (5) ; IC 44 (25).
(For explanation of symbols see FM 21-6.)

TABLE OF CONTENTS

	Paragraph	Page
CHAPTER 1. General.		
SECTION I. General	1-6	1
II. Classes of sites.....	7-9	6
III. Occupation of sites.....	10-11	7
CHAPTER 2. Basic construction of site.		
SECTION I. Access road.....	12-16	9
II. Earthwork.....	17-21	9
III. Steel and concrete.....	22-24	11
CHAPTER 3. Construction of bed and winch installations.		
SECTION I. Anchorages.....	25-36	12
II. Winch installations.....	37-43	21
CHAPTER 4. Use of bed.		
SECTION I. Bedding down.....	44-57	26
II. Tail-line mooring.....	58-68	38
III. Mooring-circle close-haul.....	69-72	48
IV. Midship mooring.....	73-76	50
CHAPTER 5. Other site installations and site maintenance.		
SECTION I. Buildings, gas cylinder stacks, and local defenses.....	77-98	57
II. Maintenance of site.....	99-116	65
APPENDIX I. Dummy sites.....		69
II. List of references.....		72
INDEX		73

~~RESTRICTED~~

ANTIAIRCRAFT ARTILLERY FIELD MANUAL

BARRAGE BALLOON SITE INSTALLATIONS

CHAPTER 1

GENERAL

	Paragraphs
SECTION I. General.....	1-6
II. Classes of sites.....	7-9
III. Occupation of sites.....	10-11

SECTION I

GENERAL

■ 1. **SCOPE.**—This manual presents the details of construction, use, and maintenance of land sites for low altitude barrage balloons. Rigging of the bed is described for securing low altitude barrage balloons by bedding down, tail-line mooring, mooring-circle close-haul, and midship mooring. Appendix I discusses dummy sites. For information on waterborne sites see FM 4-187.

■ 2. **SITE.**—A barrage balloon site is the area that contains the balloon bed and auxiliary installations necessary for inflating, mooring, and flying the balloon. The winch position, balloon maneuvering space, local defenses, gas cylinder stacks, motor parking space, operations hut, and frequently the crew quarters are all part of the site. (See fig. 1.)

■ 3. **BED.**—A balloon bed is that part of the site on which the balloon is moored when it is not flying.

■ 4. **GROUNDING.**—*a.* The primary function of barrage balloons is to fly, but circumstances often require that they be brought down to the bed for varying lengths of time. Balloons often must be grounded to prevent their loss due to adverse weather. They must be grounded for inspection and servicing. They must be grounded if demanded by tactical operational controls.



FIGURE 1.—Balloon site.

b. Basic considerations in grounding the balloon are:

(1) The balloon must be secured so that it can be put into the air with a minimum of delay when orders to fly the balloon are received.

(2) Danger of damage or destruction to the balloon due to adverse wind conditions must be reduced to a minimum.

c. Mk. VII, Mk. X, D-7, and D-8 balloons are of the low pressure ballonnet type. The low pressure ballonnet type balloon is designed to operate with very little or no internal gas pressure, and is dependent on the wind to obtain and maintain a streamlined shape. A streamlined shape is not necessary in still air, but it is very important in a high wind, because a flabby balloon is liable to damage, is hard to control, and causes excessive tension on the flying cable. A streamlined shape is obtained in the low pressure ballonnet type of balloon by wind blowing through the air-scoop into the ballonnet and forcing the ballonnet diaphragm upward; the upward movement of the diaphragm compresses the inflation gas and tightens the balloon envelope. Since the air-scoop cannot scoop up air unless the balloon is headed into the wind, it is important that the balloon be headed into the wind at all times. During flight, this position is assumed automatically by the balloon; when the balloon is grounded, it is moored so that its nose points into the wind.

■ 5. METHODS.—*a.* When the inflated balloon is not flying, there are four methods of securing the balloon on land sites: bedding down, tail-line mooring, mooring-circle close-haul, and midship mooring.

(1) Bedding down is securing the balloon close to the ground by means of ballast so that the air-scoop is just above the ground. (See fig. 9.) It is stressed that the balloon, when secured by this method, does not actually rest on the ground.

(2) Tail-line mooring is securing the balloon by the junction assembly and tail-line, the balloon being permitted to turn with the wind. (See fig. 15.)

(3) Mooring-circle close-haul is securing the balloon by the junction assembly and four handling lines, allowing restricted movement with the wind. (See fig. 20.)

(4) Midship mooring is securing the balloon by the junction assembly and a wire running line, allowing restricted movement with the wind. (See fig. 21.)

b. The situations in which the four methods of securing a balloon are used are as follows:

(1) Bedding down is used to secure the balloon in strong winds, for inspection, and for minor repairs. The balloon may be bedded down or partially bedded down for topping-up.

(2) Tail-line mooring is used to secure the balloon in readiness for quick flying. In this method of mooring, the balloon can be handled with the least number of men and ride light gusty winds with a minimum of attention. If the tactical situation requires readiness for immediate flight, the balloon may be held at tail-line mooring even in high winds. Under ordinary circumstances, however, tail-line mooring is not used in high winds or storms.

(3) Mooring-circle close-haul is used for the same reason as tail-line mooring on sites that do not have sufficient space for tail-line mooring.

(4) Midship mooring is an improved alternative for mooring-circle close-haul.

■ 6. GENERAL FEATURES OF HANDLING EQUIPMENT.—*a. Bedding down.*—The standard equipment for bedding down the low pressure ballonnet balloon is designed so that—

(1) The balloon may be hauled onto the bed by hauling on the handling lines, either manually with block and tackle or mechanically by using the gipsy-head on the winch.

(2) The balloon remains attached to the flying cable while bedded down, and actually flies close to the ground. The lift is counteracted by ballast attached in such a manner that the pull is exerted on the rigging patches in the same direction as when the balloon is aloft.

(3) No part of the balloon gets too great a load because the maximum load on any patch is determined by the amount of ballast that patch must lift.

(4) The balloon may be turned to keep its nose into the wind without removing the balloon from the bed.

b. Tail-line mooring.—The standard equipment for mooring the balloon at tail-line mooring, which should be pro-

vided on all sites where sufficient space is available, is designed so that—

(1) The balloon may be moored at the junction assembly by a wire cable pyramid, and connected at the tail to a snatch block which rides on a circular cable track.

(2) The snatch block riding on the cable track permits the balloon to swing with the wind. If the space does not permit the construction of a complete circular cable track, a fractional circle should be built in order to take advantage of this efficient method of mooring. Special effort should be made to locate a segment of the tail-line mooring circle on the down wind side of the bed.

c. Mooring-circle close-haul.—The standard equipment for mooring the balloon at mooring-circle close-haul is designed so that—

(1) The balloon may be moored at the junction assembly by a safety stop which takes the tension off the flying cable when the balloon is moored.

(2) The front handling lines are fastened to a cluster of sandbags on each side of the balloon.

(3) The rear handling lines on each side are reeved through bed blocks attached to mooring-circle anchorages on the 37-foot circle and are connected by means of a transverse stop. This arrangement enables the tail of the balloon to swing with the wind, to a more limited extent than in tail-line mooring.

d. Midship mooring.—The equipment for mooring the balloon at midship mooring is designed so that—

(1) The balloon may be moored at the junction assembly by a wire cable pyramid, as in tail-line mooring, and by a wire running line.

(2) The wire running line, which hangs under the balloon and just ahead of the rudder, is suspended from two wire bridles, rigged approximately amidships on opposite sides of the balloon.

(3) The running line is attached by a trolley assembly to a cable track around the 37-foot mooring circle.

(4) In this position the balloon is secured at only two points and is free to swing with the wind, its nose always pointing into the wind.

SECTION II

CLASSES OF SITES

■ 7. LOCATIONS.—In a balloon barrage it may be necessary to fly balloons from different types of sites. Some sites will contain ample space for installing all equipment needed for safe and speedy handling of the balloon, other sites may be in restricted areas, and still other sites may be over water. (For information on selection of sites, see FM 4-181 (when published).) As a rule, exact site locations will have been designated before those in charge of making installations arrive.

■ 8. TYPES.—*a. General.*—(1) Wherever possible a complete tail-line mooring system should be installed on a site. The next best site is one combining a partial tail-line mooring system and a mooring-circle close-haul or midship mooring system. When room for complete tail-line mooring is not available, the site should be made to yield as much tail-line mooring space on the down wind side as is possible.

(2) On sites lacking room for a tail-line mooring system or portion thereof, a mooring-circle close-haul or midship mooring system is necessary. If sufficient space is not available for at least mooring-circle close-haul or midship mooring, it normally is recommended that a different site be selected.

b. Urban sites.—Tactical situations will often require the siting of balloons in urban districts. These urban sites may be divided into three general classes: residential, industrial, and business.

✓(1) In residential districts, sites may be located in vacant lots, public parks and playgrounds, golf courses, athletic fields, school grounds, street intersections, and other open spaces.

(2) In industrial and business areas, buildings may be sufficiently scattered to permit selection of ground sites. When space is not available, it may be necessary to take over street intersections for sites, moving power lines and other obstructions. In emergencies, balloons sometimes may be

flown from alleys, courtyards, flat roofs of buildings, and other similar places too small for the usual bed installations.

c. Waterborne sites.—For information on waterborne sites, see FM 4-187.

d. Airport sites.—Balloons may be flown from airport runways by use of mobile winches. In such cases, beds for mooring the balloons when they are not flying should be along the outside of the runways.

■ 9. **RATIO.**—It is difficult to predetermine the average number of the different kinds of sites that will be established in future balloon barrages. Liaison officers from Great Britain estimate that less than one-tenth of the Mk. VII balloons in Britain are flown from water-borne sites and that about 75 percent of the land sites have either complete tail-line mooring systems or partial tail-line mooring plus mooring-circle close-haul.

SECTION III

OCCUPATION OF SITES

■ 10. **FULLY PREPARED SITE.**—*a.* An organization moving onto a completed site should find the following:

- (1) Bed leveled.
- (2) Anchorages for all ground rigging installed.
- (3) Anchorage for winch installed.
- (4) Crew quarters and operations hut complete, when needed, including sanitary and messing facilities where specified.
- (5) Access road constructed, when necessary.

b. In this situation, an occupying unit will usually perform the following tasks:

- (1) Move into the barrage area, with battalion, battery, and platoon commanders reconnoitering the prepared positions, and with troops and matériel being sent to the sites.
- (2) Go into housekeeping at each site, see that communication is established, check equipment on hand, install ground rigging on the bed, install the winch, select the gas

cylinder dump and motor parking space, prepare and inflate the balloon for flying, and construct local defenses.

■ 11. PARTIALLY PREPARED SITE.—An organization arriving at a site which has been only partly completed should go into housekeeping, see that communication is established, complete the site, and then continue as in paragraph 10.

CHAPTER 2

BASIC CONSTRUCTION OF SITE

	Paragraphs
SECTION I. Access road.....	12-16
II. Earthwork.....	17-21
III. Steel and concrete.....	22-24

SECTION I

ACCESS ROAD

■ 12. CONSTRUCTION.—If no road leads to the location selected for a site, an access road should be built immediately, so that materials and equipment can be trucked to the site.

■ 13. QUALITY.—The access road should be of a quality sufficient to hold up a 2½-ton truck fully loaded. For techniques in road-building, refer to FM 5-10.

■ 14. TURN-OUTS.—If the road is a one-way road and is fairly long, one or more turn-outs should be provided to allow for passage of vehicles.

■ 15. MAINTENANCE.—If the access road is not a public road, maintenance will be the responsibility of the using organization. Particular attention should be paid to drainage, so that the road will be passable during prolonged periods of inclement weather.

■ 16. PARKING SPACE.—Wherever possible, it is desirable to have available space at or near the site for parking of motor vehicles. This may be in the form of a loop in the access road.

SECTION II

EARTHWORK

■ 17. PLANS.—This manual showing lay-out of beds should always be on hand or readily available to those immediately directing the construction of the site.

■ 18. CLEARING THE AREA.—In preparing the site, it is necessary to clear the area of all ground obstructions which would impede efficient and safe handling of the balloon. The bed area should be cleared of all trees and stumps, but the site area should not necessarily be cleared to the ground. Small trees are valuable as a windbreak, and natural vegetation serves to camouflage and to reduce both erosion and the problem of site maintenance. However, the safety of the balloon should be the chief factor in determining how much of a site should be stripped of ground obstructions.

① 19. GRADING.—After the area is sufficiently cleared, any necessary excavating, filling, and compacting will follow. If the site is on a hillside, it may be necessary to shore up orrevet the edge of the fill or excavation. (See FM 5-15.) The slope of the bed proper should not be over 5 percent. Great

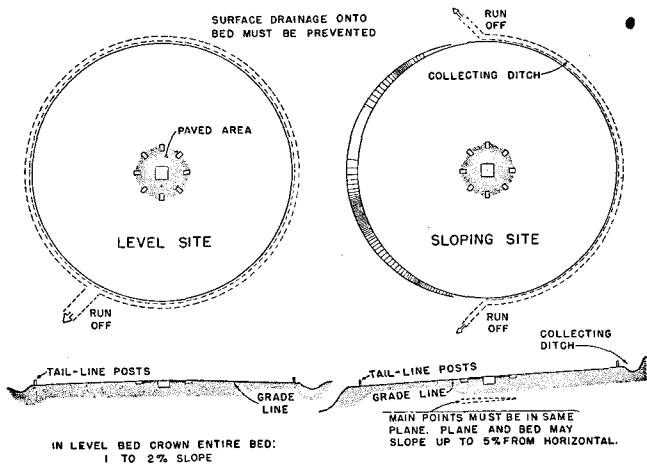

FIGURE 2.—Drainage of site.

care should be taken to assure proper bed drainage by obtaining a crowning (or watch crystal) effect; that is, completely around the bed there should be a gentle slope from the central anchorage. (See fig. 2.)

■ 20. HIGH WATER MARKS.—When sites are to be in low areas, the high water marks should be ascertained to make sure the bed is above such marks. Sources in the community in which the site is to be established probably will be able to furnish this information. If the site is in an unpopulated area, trees may be studied for water marks.

■ 21. SAFEGUARDING PROPERTY.—In constructing a site, great care is necessary to avoid damage to property adjacent to the site. Crops should not be trampled or other damage done.

SECTION III

STEEL AND CONCRETE

■ 22. STEEL.—*a.* Normally, all steel equipment except cable needed for the balloon bed—anchorage rods, flog rings, and other like equipment—will arrive at the site already fabricated to the proper dimensions.

b. When, in an emergency, it is necessary to fashion equipment on the site from scrap steel, care should be taken to see that the steel is free of rust or grease.

■ 23. CONCRETE ANCHORAGES.—To insure long life of the bed and to avoid the difficulties that must eventually develop from the use of deadman anchorages and screw pickets, all anchorages should be made of concrete. For safe anchorage in every type of soil, a standard anchorage should contain a sufficient weight of concrete to hold the load imposed on that anchorage. No attempt should be made to design anchorages so that their shape will give a deadman effect, and no dependence should be placed on the weight of the soil to be disturbed before failure.

■ 24. MIX.—The 1-3-5 concrete mix (1 part of cement to 3 parts of sand to 5 parts of gravel) is suggested for use on the bed. For other mixes, which may be required for special conditions, and for rules of thumb for mixing and curing, see tables in FM 4-198 (when published). For further details on concrete see FM 5-35.

CHAPTER 3

CONSTRUCTION OF BED AND WINCH INSTALLATIONS

	Paragraphs
SECTION I. Anchorages	25-36
II. Winch installations	37-43

SECTION I

ANCHORAGES

■ 25. **BED SPACE.**—Operations in the field require a cleared space upon which a balloon may be inflated and inspected, with equipment for mooring a balloon. In most instances it is desirable to fly the balloon from this cleared space. The area and the anchorages required for these operations constitute the balloon bed. (See fig. 3.)

■ 26. **LAYING OUT BALLOON BED.**—In laying out the bed, the steps listed below should be followed in order.

a. Select central point of bed.

b. Determine direction of prevailing wind.

c. Establish one main point exactly in the direction from which the prevailing wind blows.

d. Select fair-lead anchorage $22\frac{1}{2}^{\circ}$ to right or left of the main point established in c above.

e. Establish winch anchorage so that its right edge is in line with fair-lead anchorage and center of bed.

f. Establish first tail-line mooring-circle anchorage directly in front of center of winch anchorage.

g. Establish curb of central anchorage so that one side is perpendicular to line from bed center to winch anchorage.

h. Establish positions for the remaining main points, mooring-circle anchorages, hauling anchorages, and tail-line mooring-circle anchorages.

■ 27. **CENTRAL ANCHORAGE.**—a. The central anchorage consists of a steel anchorage rod fixed in a concrete block, a

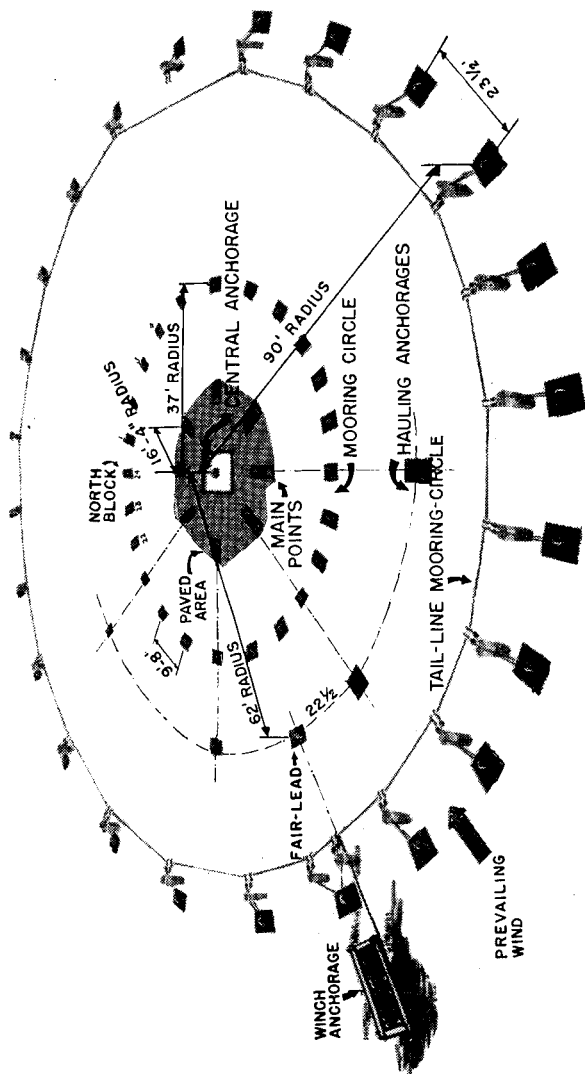

FIGURE 3.—Standard bed.

metallic grounding mat, a concrete curb, and a grounding plate with proper electrical connections. (See fig. 4.)

b. The central anchorage is placed in the center of the balloon bed, and, from its center, measurements to all points

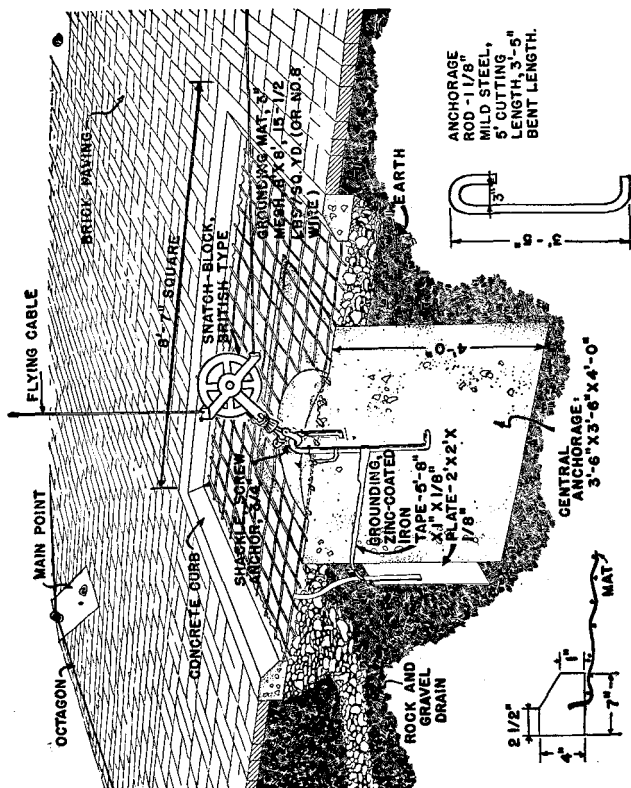

FIGURE 4.—Central anchorage.

of the bed are made. The block of the central anchorage is made of concrete and is formed to the dimensions shown in figure 4. The purpose of the crown of the block is to catch the shank of the snatch block and hold the sheave clear

when the wind forces the flying cable off at an unusual angle. The anchorage rod is placed accurately in the block so that it is in the same vertical plane as the left edge of the winch and the center of the central anchorage block. The curb extending around the center block is constructed of concrete according to the dimensions shown in figure 4.

c. The grounding mat, grounding plate, and the central anchorage rod are of the type and dimensions shown in figure 4. The grounding mat is secured in position by having the crown of the concrete block formed over its center and by having its edges embedded in the curb. This embedding prevents curling of the mat and consequent cutting of the balloon. Gravel or crushed stone is placed under the mat within the curb to provide drainage and to prevent the formation of mud. The grounding plate is electrically connected with the central anchorage rod and the grounding mat. The grounding plate and connections must have a conductivity of at least No. 4 copper wire.

■ 28. TEMPORARY CENTRAL ANCHORAGE.—When a concrete anchorage is not immediately available for the central anchorage, a temporary deadman anchorage of logs or timbers can be used (see fig. 5). Size of the deadmen and the depth to which they are buried naturally will vary with the kind of soil. For holding powers of various types of earth, see tables in FM 4-198 (when published). Dimensions suggested below are approximate.

■ 29. CONSTRUCTION.—A trench is dug about 2 feet wide, 5 feet 8 inches deep, and 8 feet long at right angles to the cable coming from the winch to the snatch block. On the side of this trench toward the winch an undercut big enough to receive the deadman is made about 5 feet below the surface. The next step is to dig two small trenches, of shovel width, in the form of an inverted V, from about 18 inches below the surface to a point about 2 feet in from each end of the large trench. See figure 5 for proper slope and other details. Two deadmen, one about 8 inches by 8 inches by 8 feet and the other about 4 inches by 4 inches by 4 feet, are cut.

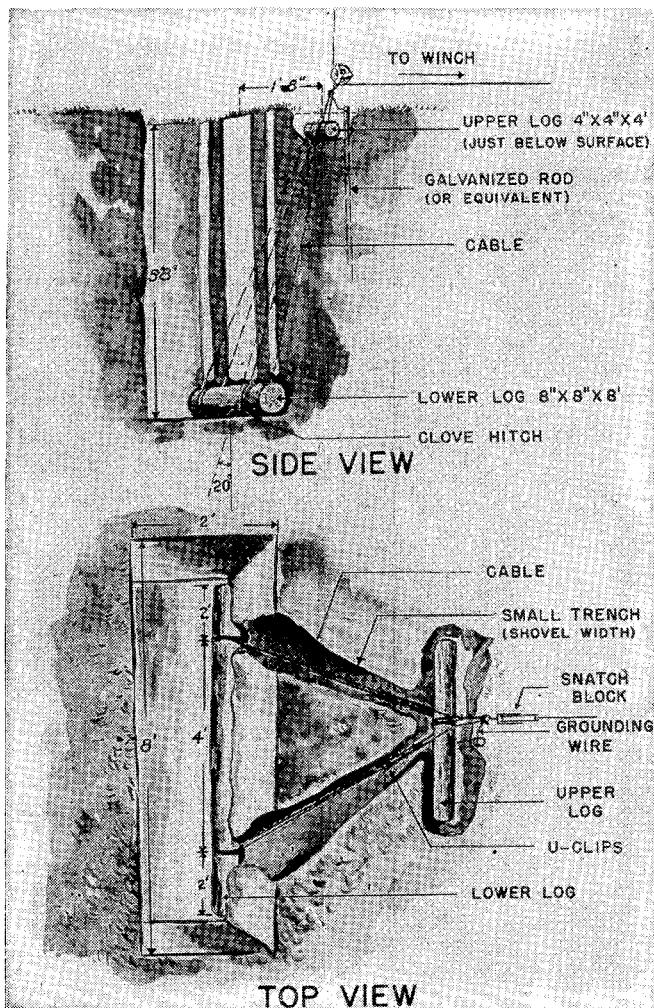

FIGURE 5.—Temporary central anchorage.

Balloon cable is fastened to the larger deadman with a clove hitch, with the crossing of the cable being on the underside of the deadman, and the deadman is placed in the large trench. Cable is then fastened to the smaller deadman, interlocking with the cable on the larger deadman via the two small trenches, and the smaller deadman is placed just below ground surface at the convergence of the two small trenches. The snatch block at the central anchorage is attached to the anchorage cable on the small deadman, and is ready for use as soon as the trenches are filled and tamped.

■ 30. GROUNDING.—Grounding the snatch block and balloon cable is accomplished, where a grounding plate and connections are not available, by driving a 10-foot, $\frac{3}{4}$ -inch galvanized rod or its equivalent into the ground close to the upper deadman and connecting it to the block by No. 4 copper wire, or by burying approximately 16 feet of grounding wire in the trench and connecting the end to the block.

■ 31. EIGHT MAIN POINTS.—*a.* Eight anchorages are evenly distributed on a radius of 16 feet 4 inches from the center of the central anchorage, the distance between centers of adjacent anchorages being 12 feet $4\frac{1}{2}$ inches. When the prevailing wind can be accurately located, one main point should be placed so that it points directly into the prevailing wind. Two bent rods with flop rings are embedded in each main point anchorage. Flop rings are placed so that when held vertically, they are in line with the center of the bed. (See figs. 3, 4, and 6.)

b. The eight main points should be in one plane so that one set of markings on the handling lines will be sufficient for hauling the balloon onto the bed. Any inclination of the plane of the main points induces difficulty in bedding down the balloon, and an inclination of 5 percent or greater in the plane of the main points may peel the handling-line patches.

c. A wire cable called the "octagon" is reeved through the outermost flop rings of the main point anchorages and

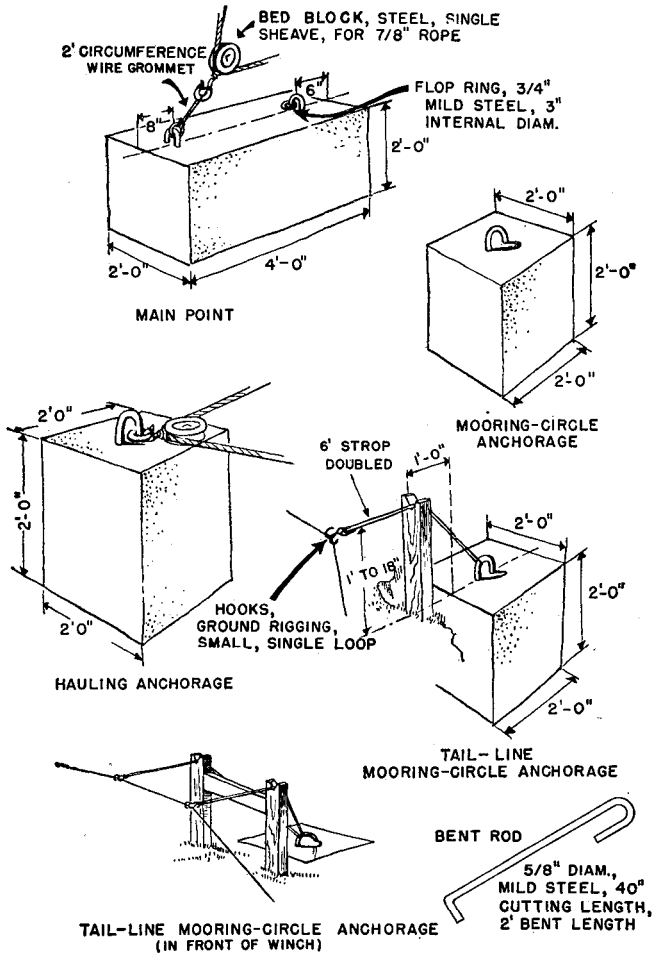

FIGURE 6.—Anchorage.

fastened taut. The octagon should be made from salvaged flying cable. (See figs. 4 and 12.)

■ 32. **MOORING-CIRCLE ANCHORAGES.**—A mooring circle of 37-foot radius is laid out from the center of the bed. On this circle 24 concrete anchorages equipped with bent rods and equally spaced 15° apart (9 feet 8 inches between bent rods of anchorages) are placed. Eight of the mooring-circle anchorages are placed so as to be radially in line with the 8 main points and the center of the bed. (See fig. 3.) Each anchorage has a number distinctly painted on it, with No. 24 on the anchorage most nearly north, and Nos. 1, 2, 3, through to No. 23 proceeding clockwise. For details of the anchorage, see figure 6. The cradle bed embraces everything up to and including the 37-foot circle. It does not include the tail-line mooring circle.

■ 33. **HAULING ANCHORAGES.**—There are four hauling anchorages and a fair-lead anchorage on a radius of 62 feet from the center of the bed. Each of the five anchorages consists of a concrete block with a bent rod; each bent rod holds a flop ring. The four hauling anchorages are located directly in line with the center of the bed and with the four consecutive main points on the side of the bed toward the winch. (See fig. 3.) Midway between the second and third of these hauling anchorages, the fair-lead anchorage is located. By the use of these anchorages, the balloon can always be hauled down with its nose within $22\frac{1}{2}^\circ$ of the wind direction. When the balloon is hauled down mechanically, the hauling cable passes through a block attached to whichever hauling anchorage will most nearly cause the nose to be brought down into the wind. The hauling cable is then led through a block on the fair-lead anchorage to the gipsy-head of the winch. For details of the hauling anchorage, see figure 6.

■ 34. **TAIL-LINE MOORING-CIRCLE ANCHORAGES.**—On a circle of 90-foot radius, 24 concrete anchorages of the same design and dimensions as the mooring-circle anchorages are placed. The first tail-line mooring-circle anchorage is located on a line between the center of the bed and the center of the

winch anchorage. The remaining 23 anchorages are equally spaced around the tail-line mooring circle at intervals of approximately $23\frac{1}{2}$ feet. (See figs. 3 and 6.) If a 90-foot radius is not possible, any radius between 80 and 90 feet may be used.

■ 35. SUBSTITUTE ANCHORAGES.—*a.* When concrete anchorages are not immediately available for the eight main points

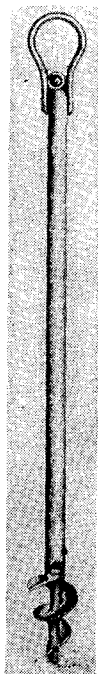

FIGURE 7.—Screw picket.

and the hauling anchorages, the deadman type of anchorage should be used. For installing the deadman anchorage, follow the general procedure outlined in this manual for emergency central anchorages and winch anchorages.

b. For the 37-foot mooring circle and the tail-line mooring circle, screw pickets may be used, either alone or lashed to deadmen.

c. If screw pickets are used, they should be about 3 feet long, with a $\frac{3}{4}$ -inch solid steel shank, or equivalent, a screw 4 to 6 inches in diameter, and a 3-inch eye on top for fastening rope or cable. Figure 7 shows one of several types. In installing a picket, it sometimes is advisable to dig a small hole 6 inches deep, insert the picket, cover it with dirt, pack the dirt, and then screw the picket into the ground for the rest of the way. In extremely hard ground, it may be necessary to dig a hole to the depth of the picket. When this is done and the picket has been placed, about 3 inches of dirt should be put into the hole and tamped. Then 3 more inches of dirt should be put in and tamped, and this repeated until the surface is reached.

■ 36. SURFACING THE BED.—a. If material is available, the bed should be paved from the central anchorage to the main points, paved or graveled to the 37-foot circle, and grassed from there to the tail-line mooring circle. The paving may be either concrete, asphalt, brick, or plank. The soil of the bed may also be consolidated by chemical treatment. Surfacing the bed is advantageous for several reasons: it prevents the formation of mud; it enables the crew to work at night with more certainty and speed; and it allows the ballast to be moved easily.

b. A gravel walk should lead toward the central anchorage from the operations hut to that point on the bed at which hard surfacing begins.

C added to list

SECTION II

WINCH INSTALLATIONS

■ 37. PURPOSE.—The winch anchorage is to provide an anchor to which a barrage balloon winch may be securely fastened.

■ 38. TYPES OF FLYING.—Balloons are flown by either indirect or direct flying, in the following manner:

a. In indirect flying, which is the usual flying method, the winch is anchored just outside the tail-line mooring circle or about 100 feet from the central anchorage, which is the ascension point. The winch should be on the up wind side of the bed to minimize the frequency with which the tail-line snatch block will interfere with the flying cable.

b. In locating the winch anchorage, a line from the central anchorage rod, running along the right edge of the winch anchorage (the edge of the winch anchorage nearest the bed being considered as the front of the anchorage), should run midway between two main points. The center of the winch anchorage should be set radially with the central anchorage rod. (See fig. 3.)

c. In direct flying the balloon flies directly from the winch, with the lead-off gear as the ascension point. The winch should be on the up wind side of the ascension point, with the lead-off gear facing down wind.

■ 39. CONCRETE ANCHORAGE.—a. The standard winch anchorage is of concrete. For dimensions see figure 8.

b. Imbedded in the anchorage are four anchor rods, bent into the shape shown in figure 8. The anchorage should be capable of sustaining a vertical lift of 3,000 pounds and should be grounded electrically. Like that of the central anchorage, this electrical grounding is done with a ground plate and connecting straps, the straps of the winch anchorage extending 8 inches above the ground level so that they can be connected to the winch.

■ 40. TEMPORARY ANCHORAGE.—In emergencies, occupying troops may use a deadman anchorage made of logs or timbers, with the standard concrete type anchorage being installed to replace it as soon as feasible.

■ 41. METHOD OF TEMPORARY ANCHORING.—In both direct and indirect flying, the winch is anchored by three deadmen, two being placed in front of the winch (that is, in front of the

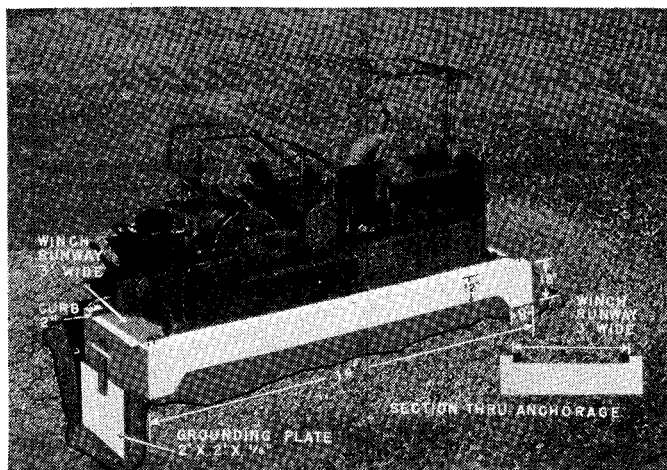

①

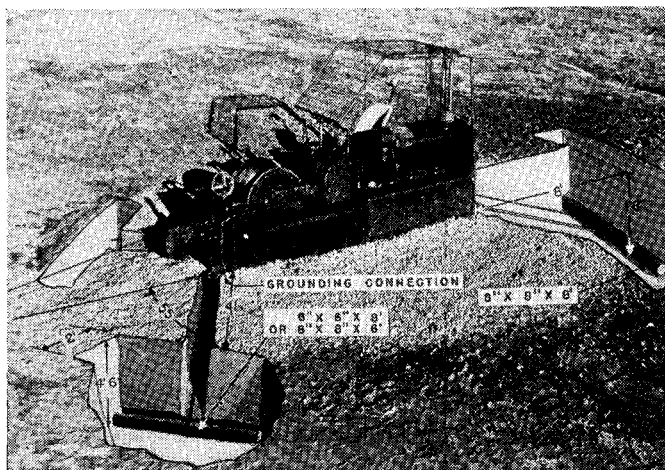

②

FIGURE 8.—Winch anchorages.

two corners nearest the lead-off gear), and one being placed in rear of the winch. (See fig. 8.) Size of the deadmen and the depth to which they are buried naturally will vary with the kind of soil. For holding powers of various types of earth, see tables in FM 4-198 (when published). The two corners of the winch nearest the lead-off gear are anchored to resist the vertical pull in case the snatch block breaks loose. Experience has shown that in many cases the deadmen on these corners will be of sufficient strength if they are timbers 6 inches by 6 inches by 8 feet or 8 inches by 8 inches by 6 feet, or logs of equal size, and are located 4 feet from the winch and buried 4 feet below the ground. In placing each of these front deadmen, a trench is dug at an angle to the cable coming from the winch to the snatch block. The trench should be 2 feet wide, $4\frac{1}{2}$ feet deep, and long enough to accommodate the deadman. On the side of this trench toward the winch, an undercut big enough to receive the deadman is made at about 4 feet below the surface. At the midpoint of the trench, a small trench of shovel width is dug toward the winch. The bottom of this trench will slope at about 45° . Balloon cable is fastened to the deadman by a clove hitch, with the crossing of the cable being on the underside of the deadman, which is placed in the trench. The log should not be notched, since pull alone will cause the cable to bite into the wood and hold. Several stakes may be driven into the side of the trench just over the deadman to prevent slippage. The ends of the cable then are passed up the inclined trench to the ring on the corner of the winch, are passed through the ring from opposite directions, and clamped with U-clips 6 or 8 inches below the ring. The U-part of the clip should be placed on the running end of the cable. The two rear corners of the winch are anchored to resist a horizontal pull toward the central anchorage. Usually, a deadman 8 inches by 8 inches by 8 feet is of sufficient size, if buried 8 feet in rear of the winch and at a depth of 4 feet. The deadmen are anchored to the winch by means of cable and U-clips, as described above.

■ 42. **GROUNDING.**—The winch frame is electrically connected to the ground, and electricity dissipated, by one of the following or equivalent: a $\frac{3}{4}$ -inch 10-foot pipe, a zinc-coated iron plate, or a 15-foot No. 4 copper wire buried in the ground, which is kept wet.

■ 43. **TRUCK WINCH ANCHORAGE.**—*a.* A truck-mounted winch should be anchored on each of the four corners, following the general principles outlined for anchoring the winch on the ground. The truck's weight is not to be considered in determining anchorage strength, since this weight should be allowed as a safety factor.

b. The truck frame is electrically connected to the ground by a wire capable of carrying 2,500 amperes. This is a copper cable similar in size to an automobile battery cable. If no large wire is available, smaller wire can be wrapped together to form a larger cable. In no case should a wire smaller than $\frac{1}{4}$ inch be used.

CHAPTER 4

USE OF BED

	Paragraphs
SECTION I. Bedding down.....	44-57
II. Tail-line mooring.....	58-68
III. Mooring-circle close-haul.....	69-72
IV. Midship mooring.....	73-76

SECTION I

BEDDING DOWN

■ 44. **NECESSITY.**—The safest and most effective method of securing the balloon is bedding down (see fig. 9). If the tactical situation permits, the balloon is bedded down for inspection, for minor repairs, and for securing the balloon in winds unsafe for a close-haul mooring system. Since even a well-drilled crew takes about 4 minutes to fly the balloon from a bedded-down position, certain tactical situations may make it inadvisable to bed down. The balloon should be bedded down when grounded for extended periods.

■ 45. **POINT OF ATTACHMENT.**—The balloon is hauled down by winch until it is at point of attachment, that is, the junction assembly is within 3 to 6 feet of the central anchorage snatch block.

■ 46. **BED BLOCKS.**—Eight bed blocks are attached to wire grommets on the outer flop rings of the main points (see fig. 6). The eight main points permit the balloon to be hauled onto the bed with its nose pointing in any of eight directions.

■ 47. **WIRE SPIDER.**—Attached to the end of the hauling cable or hauling rope is a wire spider, to which the handling lines are tied when the balloon is to be hauled onto the bed. The

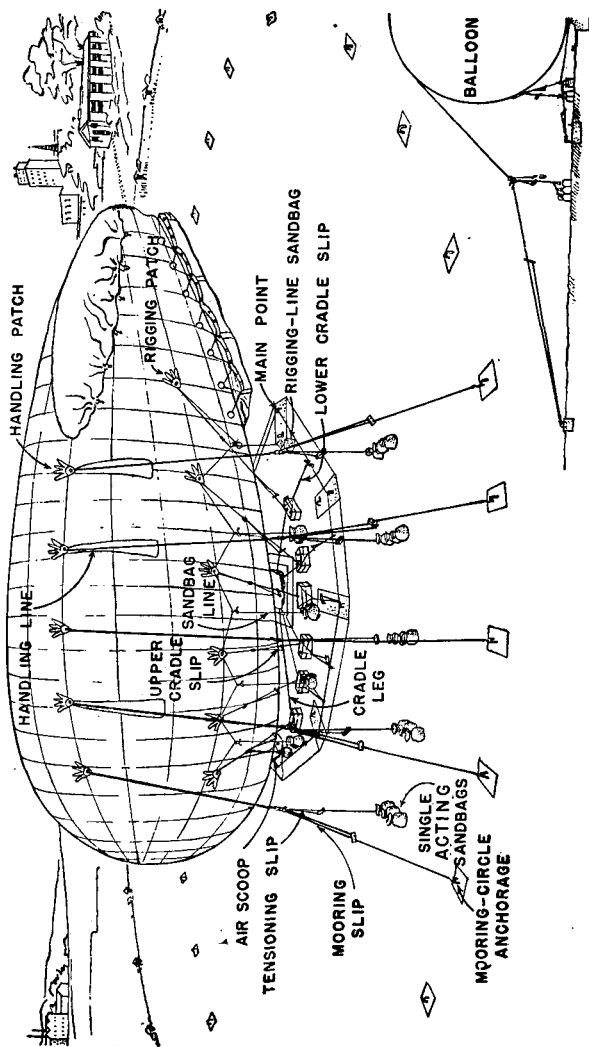

Figure 9.—Balloon bedded down.

spider consists of six legs, each terminating in an eye. For design and dimensions, see figure 10.

■ 48. ATTACHING HANDLING LINES TO WIRE SPIDER.—*a.* The free ends of the handling lines on each side of the balloon are reeved through three consecutive bed blocks. That is, six bed blocks are used, leaving the bed block under the nose and the bed block under the tail free. Each handling line is then attached to an eye of the wire spider with a swab hitch, the closest handling lines to the shortest legs of the spider, the farthest handling lines to the longest legs of the spider.

b. (1) The handling lines are marked at the point where they are to be tied onto the spider. Front and rear lines are marked at two points. These markings are necessary since the balloon may be hauled down with either its nose or tail in the direction of the spider. Obviously if the tail of the balloon is in the direction of the spider, the rear handling lines will be closest to the spider. In this event, they will be pulled through the eyes of the spider and tied to it at the second marking from the end of the line; if, on the other hand, the nose of the balloon is pointing in the direction of the spider, the rear handling lines are then the farthest ones from the spider and are consequently tied into it at the first marking from the free end of the line. The same procedure, of course, is followed with the front handling lines. All measurements are made from the upper ends of the lines. The following approximate measurements are used:

	<i>Hauling from tail</i>	<i>Hauling from nose</i>
Front handling lines	(D-7) -----62 feet	51 feet
	(D-8) -----67 feet	54 feet
Center handling lines	(D-7) -----61 feet	61 feet
	(D-8) -----64 feet	64 feet
Rear handling lines	(D-7) -----51 feet	62 feet
	(D-8) -----54 feet	67 feet

(2) The handling lines may be marked by passing a short length of balloon fabric through one lay of the rope at the prescribed distance. It is important that these distances

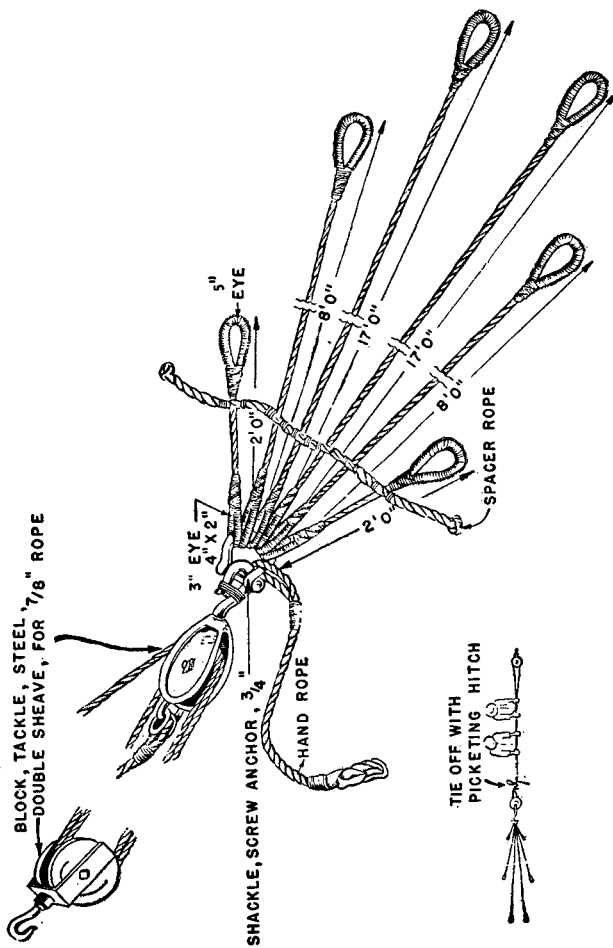

FIGURE 10.—Wire spider and tackle for manual haul-down.

be checked frequently, since even manila rope will stretch or shrink and substandard rope will vary even more. Variation of handling-line markings makes bedding down more difficult.

■ 49. HAULING DOWN.—After the handling lines are reeved through the bed blocks and attached to the spider, the balloon is hauled down onto the bed by power applied to the hauling cable. Power may be applied to the spider either mechanically by use of the gipsy-head of the winch, or manually by block and tackle. (See FM 4-187.)

■ 50. EQUIPMENT FOR MANUAL HAUL-DOWN.—For manually hauling the balloon from point of attachment, a tackle consisting of two double blocks and 200 feet of $\frac{3}{4}$ -inch manila rope (or equivalent) is connected to the shackle of the wire spider and to the hauling anchorage, and is tied off with a picketing hitch. (See fig. 10.)

■ 51. CRADLE.—*a. Cradle legs.*—(1) The cradle of the bed, which remains rigged at all times, consists of 12 legs of wire cable or 1-inch manila rope (or equivalent). Each cradle leg is constructed with a small eye-splice at the inner end and a 5-inch eye-splice at the outer end (see fig. 11). The lengths of the cradle legs used for the D-7 balloon are as follows:

Legs Nos. 1 and 6 (4 legs) ---- 12 feet 6 inches over-all.

Legs Nos. 2 and 5 (4 legs) ---- 11 feet over-all; straight cut splices 1 foot 6 inches from external eye.

Legs Nos. 3 and 4 (4 legs) ---- 8 feet over-all.

(2) A wire strop 1 foot 2 inches long is reef-bent onto the inner eye of each of the long legs of the cradle (12 feet 6 inches) when the D-8 balloon is to be bedded down. Four strops are used.

b. Attachment to central anchorage.—The small eyes of each set of legs are reeved onto a shackle, and each shackle is attached to the rod of the central anchorage by an 18-inch wire strop (see fig. 11).

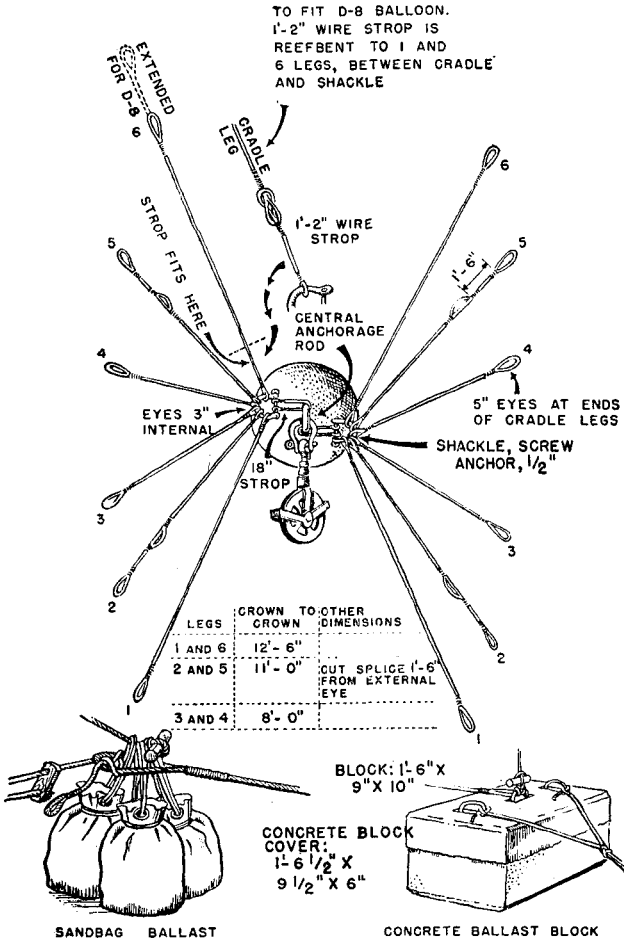

FIGURE 11.—Cradle and ballast.

c. *Cradle ballast.*—Cradle ballast is attached to the outer eye of each cradle leg (see figs. 11 and 12). Ballast may be

in the form of clusters of three sandbags, weighing approximately 120 pounds, or concrete blocks. Concrete blocks are superior to sandbags in that they do not deteriorate through friction with the bed. The ballast blocks should be covered to prevent wear of the balloon on rough edges. The blocks do not normally require lifting and are easily dragged along the ground by the slips to which they are attached or with a grapple. For details of a concrete ballast block and block cover, see figure 11. Each sandbag should weigh 40 pounds and should be rigged as shown in figure 13.

■ 52. CRADLE SLIPS AND LINES.—*a. General.*—Twenty slips (ropes rigged with adjusting blocks) and four lines are used on the cradle. These cradle slips (9 feet long) and lines (6 feet long) are constructed of $\frac{3}{8}$ -inch manila rope (or equivalent). Two grommets are lark's-headed onto the octagon between each two main points (total 16).

b. Lower cradle slips and lines.—The legs of the cradle are held to the wire octagon by eight lower cradle slips and four cradle lines. The cradle lines are used where space is so limited as to prohibit the proper use of the adjusting blocks on slips. The cradle slips are attached to the eyes holding the ballast of Nos. 2, 3, 4, and 5 cradle legs by a single sheet-bend if sandbag ballast is used, or to the concrete ballast blocks by means of a rope bridle (see fig. 11). The hooks in the bights of the lower cradle slips are hooked to grommets on the octagon. The four cradle lines are attached by a single sheet-bend to the eyes holding the ballast of Nos. 1 and 6 cradle legs if sandbag ballast is used, or to the concrete ballast blocks by means of a rope bridle. The cradle lines are attached to grommets on the octagon by means of a single bowknot. All lower cradle slips and lines are firmly tensioned. Their purpose is to keep the cradle legs fully extended in the direction of the balloon rigging patches, and to prevent the cradle ballast from shifting.

c. Upper cradle slips.—The balloon is held to the cradle ballast by 12 upper cradle slips. The free end of each upper cradle slip is fixed to a straight toggle and attached to the cradle leg ballast (see figs. 9 and 11). All upper cradle slips are hooked to bedding strops.

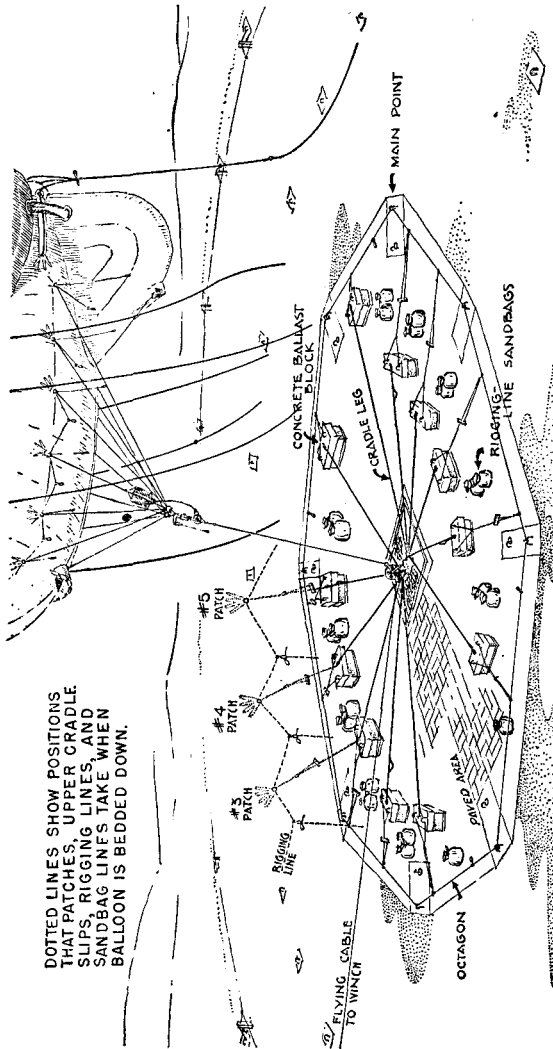

DOTTED LINES SHOW POSITIONS THAT PATCHES, UPPER CRADLE SLIPS, RIGGING LINES, AND SANDBAG LINES TAKE WHEN BALLOON IS BEDDED DOWN.

FIGURE 12.—Cradle bed prepared for balloon.

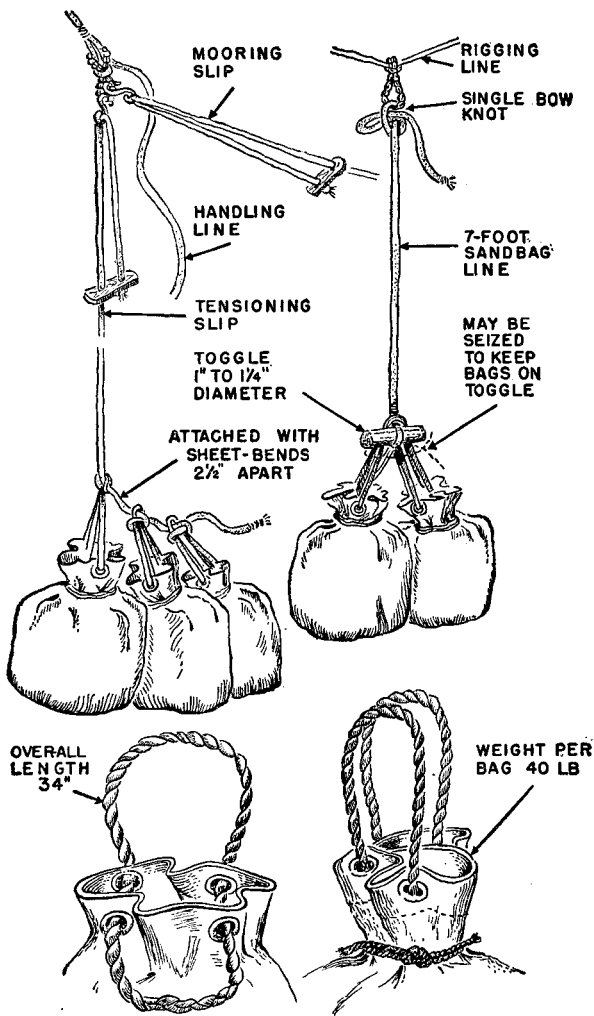

FIGURE 13.—Rigging and use of sandbags.

d. Bedding strops.—Flying with the balloon from each rigging patch is a bedding strop. These strops are made of $\frac{3}{8}$ -inch manila rope (or equivalent) with a soft eye in each end, and are lark's-headed to the rigging patches. The overall lengths of the strops are as follows:

	<i>D-7 or Mk. VII</i>	<i>D-8</i>
No. 1 rigging patch-----	1-foot strop	1-foot strop
No. 2 rigging patch-----	2-foot strop	2-foot strop
No. 3 rigging patch-----	3-foot strop	3-foot strop
No. 4 rigging patch-----	4-foot strop	4-foot strop
No. 5 rigging patch-----	5-foot strop	5-foot strop
No. 6 rigging patch-----	6-foot strop	8-foot strop

■ 53. RIGGING-LINE SANDBAGS.—*a. General.*—Part of the ballast of the balloon consists of sandbags attached to the rigging lines on each side of the balloon envelope (see figs. 9 and 13).

b. Sandbag lines.—Twelve sandbag lines of $\frac{3}{8}$ -inch manila rope (or equivalent), 7 feet long, are used in bedding the balloon. At their upper ends, ten of these lines are attached by a single bowknot to grommets on the rigging line. At the lower ends, each of the lines is toggled to two sandbags. Each of the two other lines is tied, one on each side of the balloon, to the bedding strop of the first rigging patch and toggled to a single sandbag. These two sandbags prevent the hooks of the cradle slips at the nose of the balloon from pressing into the balloon envelope.

■ 54. MOORING SLIPS.—Ten mooring slips are used to moor the balloon to the mooring-circle anchorages. These slips are constructed of $\frac{3}{8}$ -inch manila rope (or equivalent), 25 feet long. The slips are constructed with a large hook eye-spliced into the free ends. The small hook (in the bight) of each mooring slip is hooked into a grommet reef-bent onto the cut-splice in each handling and mooring line. The large hooks of the mooring slips are hooked into the rods of the mooring-circle anchorages. (See fig. 9.)

■ 55. TENSIONING SLIPS.—Ten tensioning slips are used to maintain tension on the mooring and handling lines. These

slips are constructed of $\frac{3}{8}$ -inch manila rope (or equivalent), 12 feet long. Each slip is hooked at the same point at which the mooring slips are attached, that is, to the grommet on the handling and mooring lines. When properly adjusted, the slips tension the handling and mooring lines so that they are tangent to the envelope of the balloon. Three sandbags are attached to the lower end of each tensioning slip at $2\frac{1}{2}$ -inch intervals, arranged so as to have a shock absorber action. (See figs. 9 and 13.)

■ 56. FURLING THE RUDDER AND FINS. ⁷⁰¹ ~~a.~~ *General.*—When the balloon is bedded down for a period of time, the rudder and fins must be furled. Furling is necessary to prevent the wind from tossing the fins and rudder around and damaging them. It is particularly important in keeping the rudder deflated and thus preventing it from rubbing on the ground. Standard equipment for furling consists of a rudder protection sheet 7 by 26 feet and two fin-furling lines 32 feet long for the D-7, and 38 feet long for the D-8.

b. *Furling the rudder.*—The rudder is deflated and drawn up close to the envelope of the balloon by means of the rudder protection sheet held in place by cords and hooks.

c. *Furling the fins.*—In furling the fins, it is necessary to use a 20-foot stepladder, which is placed with the steps facing the balloon. Setting the ladder up in this way is highly important in order to prevent injury to personnel and damage to the balloon. In this position the ladder is braced to the maximum; consequently, surges of the balloon are unlikely to turn it over. Furthermore, a man on the ladder can work more efficiently from this position and can keep the balloon from rubbing against the ladder and being damaged.

1701
 ■ 57. ADDITIONAL EQUIPMENT FOR STORM PRECAUTIONS.—In high winds or when a storm warning has been issued and the balloon is to be bedded down, the following additional equipment is necessary (see fig. 14):

a. (1) For the D-7 balloon, four mooring-line extensions of $\frac{1}{2}$ -inch manila rope (or equivalent), 25 feet long, eyespliced at one end.

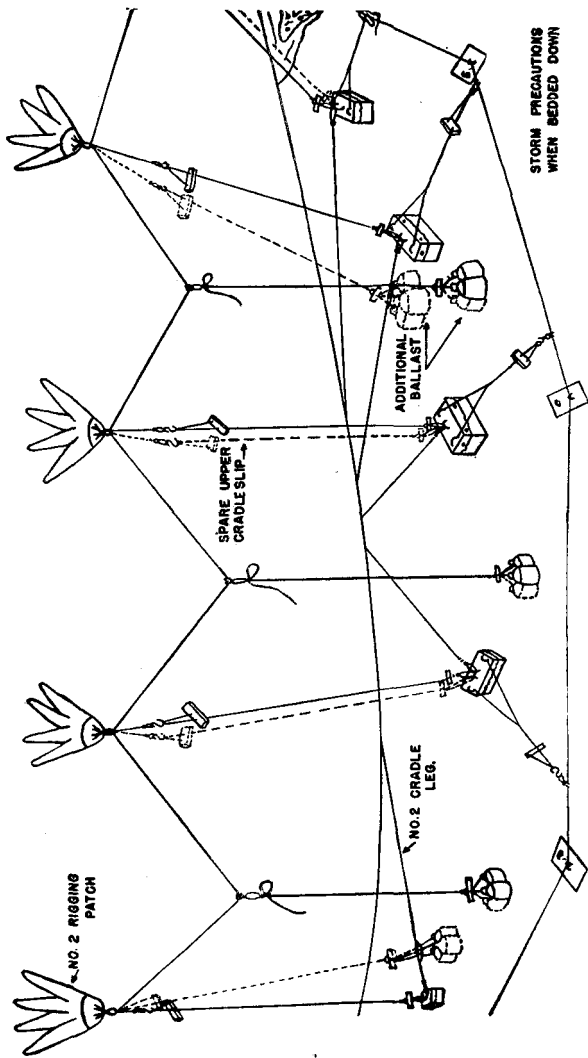

FIGURE 14.—Additional equipment for storm precautions.

(2) For the D-8 balloon, four mooring-line extensions of $\frac{5}{8}$ -inch manila rope (or equivalent), 30 feet long, eye-spliced at one end.

b. (1) Extra sandbags or ballast blocks to provide additional ballast for Nos. 2 and 5 cradle legs.

(2) For the D-8 balloon, it may also be necessary to attach a ballast block or three additional sandbags to the large eye of each cradle leg.

c. An extra set of bedding strops.

d. An extra set of upper cradle slips.

e. One extra sandbag for each sandbag line.

SECTION II

TAIL-LINE MOORING

■ 58. GENERAL.—*a.* When the balloon must be ready for quick flying, the most efficient and desirable method of securing it in all but severe weather is tail-line mooring. At tail-line mooring the balloon is secured at only two points: at the junction assembly by the safety strop and wire pyramid; and at the tail by the tail-line assembly and tail-line bungee assembly. (See par. 6*b* and fig. 15.) The flying cable remains attached to the balloon.

b. Equipment necessary for tail-line mooring includes: tail-line mooring-circle anchorages; tail-line mooring-circle cable, posts, and wire-cable strops; a handy-billy; a pyramid; a handling-line bag; and a tail-line bungee assembly.

■ 59. TAIL-LINE MOORING-CIRCLE CABLE.—The cable which forms the tail-line mooring circle is held in place by wire strops reeved through the rods of the tail-line mooring-circle anchorages and passed over the tops of wooden posts. The cable must be taut when held by the strops of 23 anchorages. On the tail-line mooring-circle cable runs the block attached to the lower end of the bungee assembly, the upper end of which is attached to the tail of the balloon by a toggle. The balloon is thus allowed to turn with the wind, its nose, in the manner of a weathercock, always pointing into the wind.

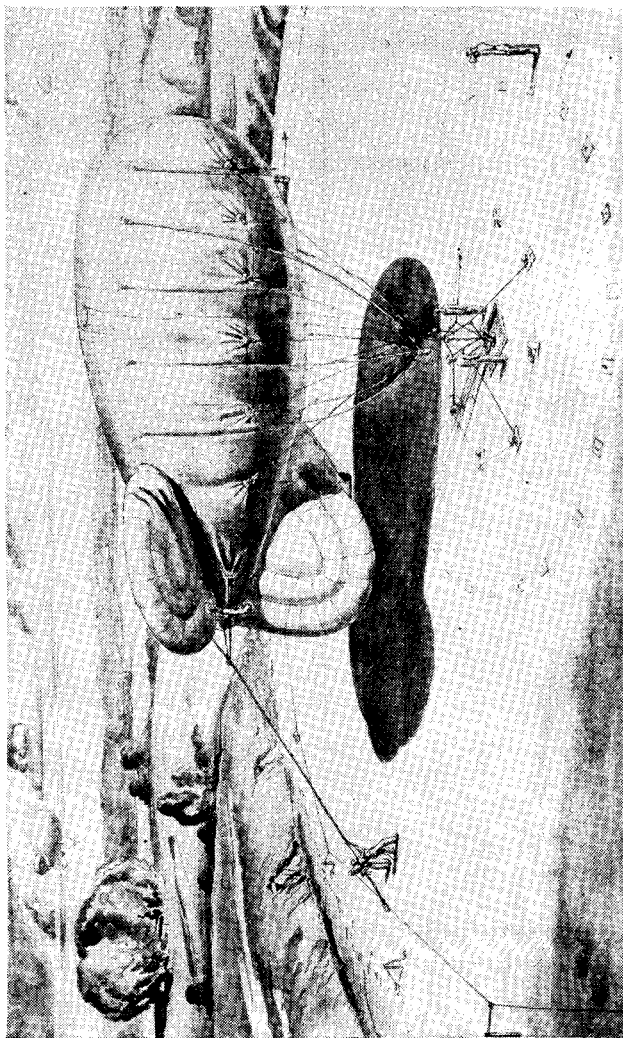

FIGURE 15.—Balloon at tail-line mooring.

■ 60. **TAIL-LINE MOORING-CIRCLE POSTS.**—*a.* About 2 feet inward from the rods of the tail-line mooring-circle anchorages (see par. 34) are the tail-line mooring-circle posts, which are of wood (2- by 4-inch minimum) with a triangular groove cut in the top. On a level bed the posts are driven into the ground until about 18 inches remain above the surface. If the ground along the tail-line mooring circle is uneven, the posts are left at varying heights above the ground, so that their tops compensate for the unevenness of the ground and keep the tail-line mooring-circle cable in an approximate plane. (See fig. 16.)

b. Twenty-five tail-line mooring-circle posts are used. Two posts are placed 2 feet apart, one on each side of the tail-line mooring-circle anchorage in front of the winch anchorage, with a spacer brace in between (see fig. 16). Directly in front of these two posts the tail-line mooring-circle is joined by means of clips or nicopress sleeves. The other 23 posts are placed around the tail-line mooring circle on a line between the bent rods of the other tail-line mooring-circle anchorages and the center of the bed.

■ 61. **STROPS.**—*a.* Twenty-five strops made of wire cable, normally 6 feet long, with a hook spliced in each end, are used to support the tail-line mooring-circle cable.

b. Two strops are used at the junction of the cable, one on each side of the cable clips or nicopress sleeves. These strops are reeved through the bent rod in the tail-line mooring-circle anchorage opposite the winch anchorage, and each of them is passed through the notch on one of the posts on each side of the anchorage. The hooks are then fastened over the cable. (See fig. 16.)

c. Each of the remaining 23 strops is reeved through the bent rod of one of the tail-line mooring-circle anchorages, passed through the notch of the corresponding post, and engaged by means of the hooks to the cable. Since the notch in the top of the post is approximately 18 inches above the ground, the strop passing over it keeps the cable also about 18 inches above ground. That is, the strop, being reeved through the rod of the anchorage and passed over the post,

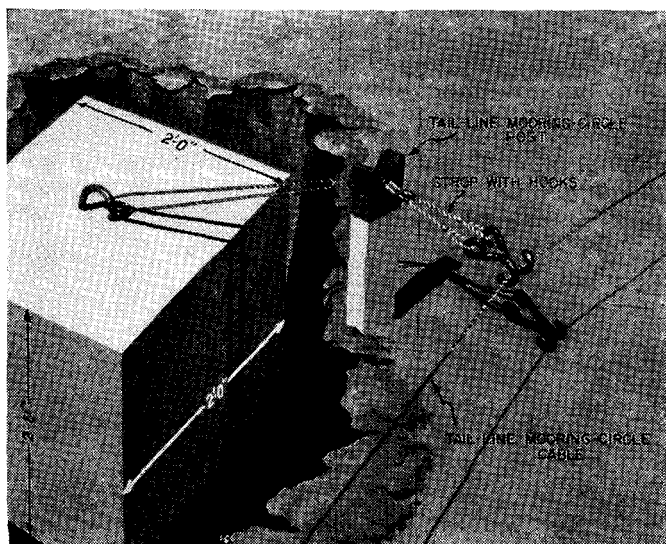

①

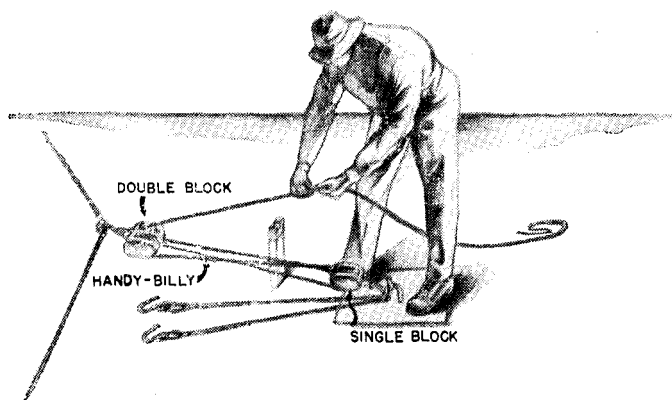

②

FIGURE 16.—Tail-line mooring-circle equipment.

creates enough tension to hold the cable at about the same height as the notch in the post.

d. The hooks are placed in opposite directions when supporting the tail-line mooring-circle cable.

■ 62. ADJUSTING THE MOORING CIRCLE.—*a.* When the balloon is at tail-line mooring, one strop is always detached from the tail-line mooring-circle cable. The block to which the tail line is attached is thus free to ride two sections of the cable. When the wind shifts sufficiently to bring the block into proximity with one of the supporting strops, it is necessary to open a new section of the cable and to close the one no longer required by the movement of the block. This switch is made by releasing one of the supporting strops and by reengaging the one previously released.

b. To engage and release the strops, a tackle arrangement (sheave and pulley) called a handy-billy is used (see fig. 16). The handy-billy enables one man to make the switch. The hook on the double block is placed over the cable, the hook on the single block is attached to a mooring-circle anchorage rod, and pull is exerted away from the cable.

■ 63. PYRAMID.—*a. General.*—The balloon is moored at the junction assembly by a junction strop and safety strop. Four pyramid legs are used to restrict movement of the safety strop.

b. *Safety strop.*—The safety strop is used to take the lift of the balloon off the flying cable. The safety strop is 5 feet 10 inches long, made of wire cable, eye-spliced at each end around thimbles. The strop is shackled at its lower end to the central anchorage rod and at its upper end by a quick release shackle to the lower end of the junction strop. (See fig. 17.)

c. *Rip cord strop.*—A rip cord strop, made of $\frac{3}{8}$ -inch manila rope (or equivalent), 5 feet 6 inches long and eye-spliced at each end, has its lower end on the shackle with the safety strop. The rip cord strop is seized to the safety strop at intervals of about 18 inches, leaving the upper eye seized by its throat to the safety strop (see fig. 17). When the balloon

is tail-line moored, the rip cord is transferred from the flying cable to the upper eye of the rip cord strop.

d. Pyramid legs.—The pyramid legs are attached at their lower ends to the inner flop rings of four main points, and at their upper ends to the quick release shackle (see fig. 17). On a level site the pyramid legs are 15 feet 9 inches long. It is necessary to vary this length on sloping sites so that the quick release shackle will be vertical above the central anchorage rod.

■ **64. HANDLING-LINE BAG.**—The ends of the handling lines are coiled and placed in a bag, which is perforated at the bottom to prevent the accumulation of rain water and consequent rotting of ropes. The handling-line bag hangs free when the balloon is flying but is attached to the junction assembly by a small rope when the balloon is close-hauled. Bagging the handling lines prevents them from fouling on the ground rigging when the balloon is moored. When the balloon is flying, bagging also keeps the lines from tangling around the parachute or otherwise fouling the lethal device.

NOTE.—Two handling line bags may be necessary for the D-8 balloon.

■ **65. TAIL-LINE RIGGING.**—The tail of the balloon is connected by means of a tail-line assembly and a tail-line bungee assembly to the tail-line mooring-circle cable (see fig. 18).

■ **66. TAIL-LINE ASSEMBLY.** *a. Components.*—The tail-line assembly includes all parts of the tail-line rigging which fly with the balloon. It consists of a tail-line bridle, a tail line, and a tail-line extension.

b. Tail-line extension.—The tail-line extension, which must be made by the using troops, is 25 feet long, of ½-inch cotton rope. When used with a double strop tail line, the tail-line extension has a 6-inch eye in one end and is lark's-headed just above the 8-inch eye in the tail line. When used with the single strop tail line, the tail-line extension is short-spliced into the tail line 1 foot above the 8-inch eye, with the splice toward the center of the tail line.

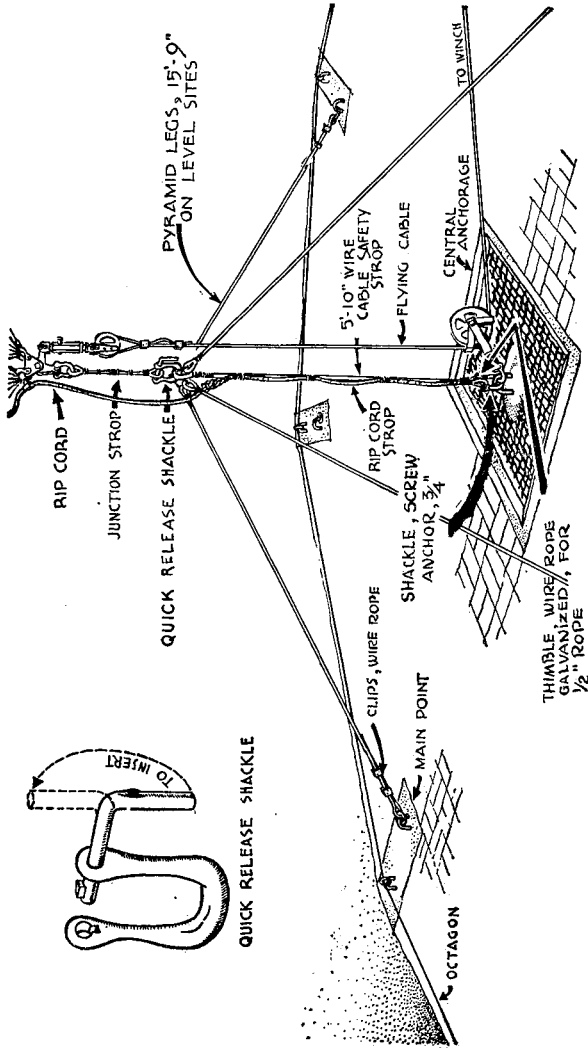

FIGURE 17.—Pyramid and quick release shackle.

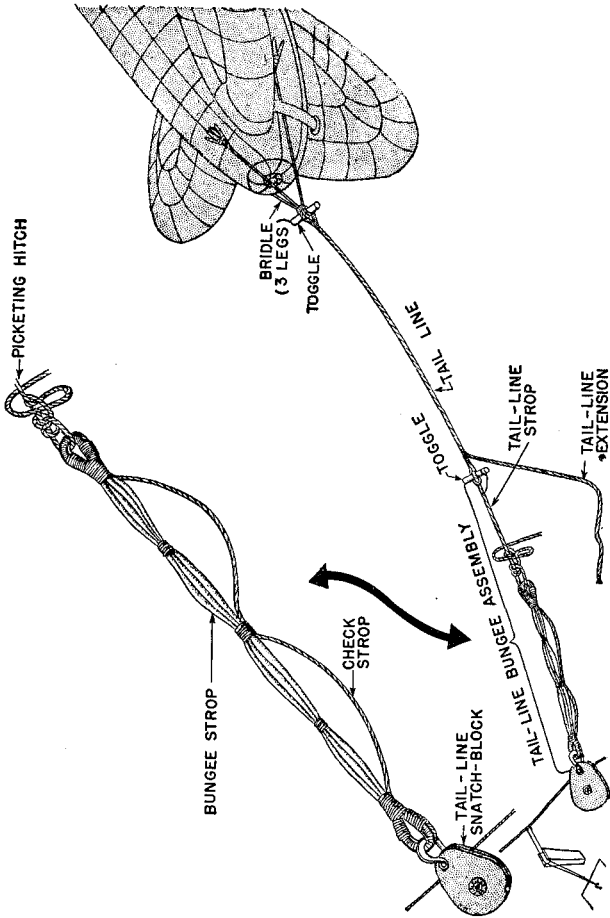

FIGURE 18.—Tail-line rigging.

CI
67. **TAIL-LINE BUNGEE ASSEMBLY.**—*a. General.*—The tail-line bungee assembly includes all parts of the tail-line rigging which do not fly with the balloon. It consists of a tail-line strop with toggle, a bungee strop, a check strop, and a snatch block. (See fig. 18.)

b. Tail-line strop.—The tail-line strop is made of $\frac{3}{4}$ -inch manila rope (or equivalent), 15 feet long, with a soft eye in the upper end. The eye is connected to the tail line by a 14-inch toggle. The lower end of the strop is reeved through the upper eye of the bungee strop and tied to its standing part with a picketing hitch. The 14-inch toggle is secured to the tail-line strop by a retaining cord.

c. Bungee strop.—The bungee strop is 4 feet long, made of rubber cords, $\frac{5}{16}$ -inch in diameter, and constructed as shown in figure 18. The upper eye of the bungee strop is attached to the tail-line strop, and the lower eye is shackled to a block which runs on the tail-line mooring-circle cable. Retracting and stretching with the pull of the balloon, the bungee strop tends to keep the tail of the balloon under tension at all times.

d. Check strop.—A check strop made of $\frac{1}{2}$ -inch manila rope (or equivalent), 6 feet long, with a soft eye in each end, is seized to the bungee strop at the center, as shown in figure 18, and is secured with the bungee strop at either end. The check strop prevents the bungee strop from going beyond its elastic limit and being broken.

e. Tail-line snatch block.—The tail-line snatch block contains a 9-inch sheave and runs on the tail-line mooring-circle cable.

68. **TAIL-LINE BYPASS.**—When the wind is blowing from directly opposite the front of the winch anchorage, the movement of the tail-line snatch block will be blocked by the clips or nicopress sleeves on the tail-line mooring-circle cable, in front of the winch. To remedy this a cable bypass may be constructed and installed as shown in figure 19. To use the bypass, the tail-line snatch block is transferred from the tail-line mooring-circle cable to the bypass cable. When not in

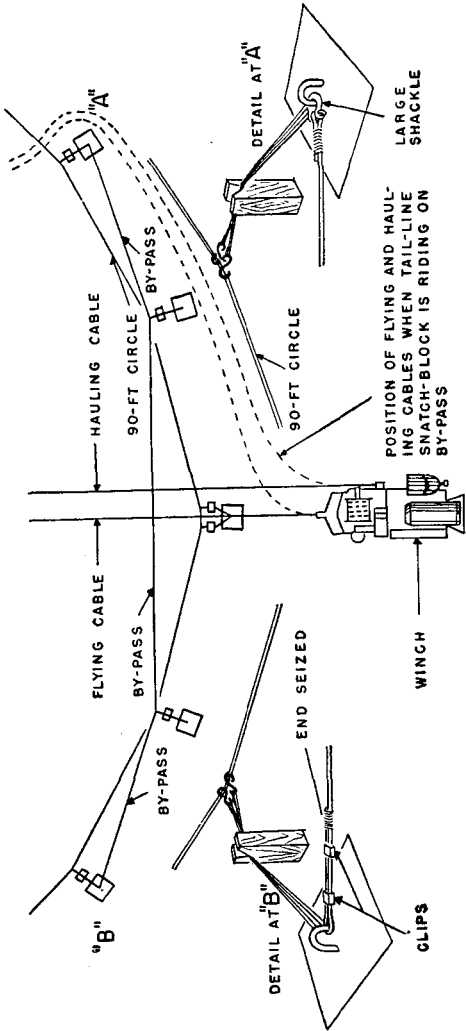

FIGURE 19.—Tail-line bypass.

use the bypass is unshackled and coiled at the anchorage to which one end of the bypass is clamped.

SECTION III

MOORING-CIRCLE CLOSE-HAUL

■ 69. GENERAL.—*a.* Mooring-circle close-haul is one of two substitutes for tail-line mooring when a sufficient area for tail-line mooring is not available. (The other substitute is midship mooring, discussed in section IV, ch. 4.) Mooring-circle close-haul is neither as safe nor as satisfactory as tail-line mooring; it requires a larger crew and more time. Furthermore, the balloon will not stand as much wind at mooring-circle close-haul as it will at tail-line mooring.

b. When the balloon is at mooring-circle close-haul, the lift is principally overcome by a safety strop attached to the central anchorage and to the junction strop. The flying cable remains attached to the balloon. To restrain the balloon in gusty winds, each front handling line is anchored to clusters of sandbags. Each rear handling line is reeved through a bed block attached to a mooring-circle anchorage and then tied to a transverse strop. The transverse strop is tensioned by a running tensioning slip which is attached to straight cut-splices in the transverse strop and which runs through a small block attached to the junction assembly. (See fig. 20.)

c. Equipment necessary for mooring-circle close-haul includes the following: a safety strop, a rip cord strop, sandbag spiders and sandbags, snubbers, bed blocks, a transverse strop, and a running tensioning slip.

■ 70. ATTACHMENT AT CENTRAL ANCHORAGE.—*a.* *Safety strop.*—The safety strop is used to take the lift of the balloon off the flying cable. (See par. 63 and figs. 17 and 20.)

b. *Rip cord strop.*—When the balloon is mooring-circle close-hauled, the rip cord is transferred from the flying cable to the upper eye of the rip cord strop (see par. 63).

■ 71. REAR HANDLING LINES.—*a.* *Bed blocks.*—Two bed blocks are attached to the mooring-circle anchorages slightly in the

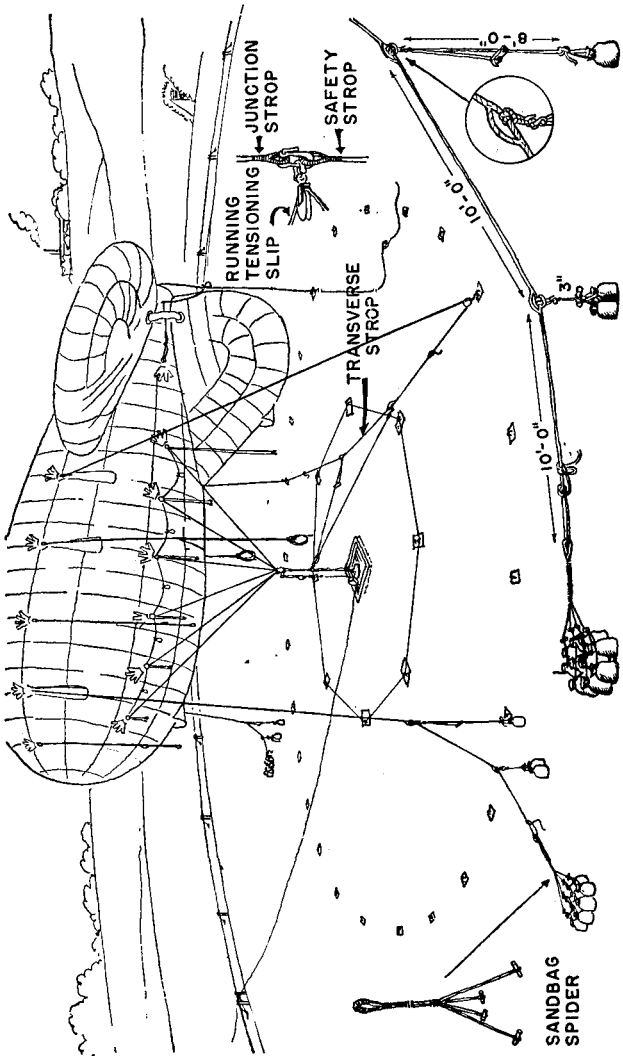

FIGURE 20.—Balloon at mooring-circle close-haul.

rear of each of the rear handling patches of the balloon. When the blocks are properly located, seven vacant mooring-circle anchorages remain between the anchorages to which the blocks are attached. The rear handling lines are reeved through these two bed blocks and are attached by a swab hitch to the ends of the transverse strop. (See fig. 20.)

b. Transverse strop.—The transverse strop, generally made of flying cable, is 25 feet long, and eye-spliced at each end with an eye the same size as the large eye on the wire spider. The transverse strop also has straight cut-splices 5 feet from each end.

c. Running tensioning slip.—A running tensioning slip of $\frac{1}{2}$ -inch rope, 36 feet long, with a hook on the running end as well as in the bight, is used to tension the transverse strop. The hooks of the tensioning slip are hooked to the transverse strop at the cut-splices. The slip runs through a block attached to the quick release shackle (see fig. 20). When the close-haul has been completed, tension will be applied to draw the transverse strop about 5 feet nearer the junction assembly.

■ 72. FRONT HANDLING LINES AND SNUBBERS.—*a. Attachment of lines.*—Each front handling line is extended out from the balloon at the normal angle to its respective patch and is tied with a picketing hitch to the eye of a rope spider that holds a cluster of sandbags. For details of the sandbag spider see figure 20. About 5 feet of line should be allowed to make the picketing hitch, and the line should be almost taut when tied.

b. Snubbers.—Looped cut-splices are made in each of the front handling lines at 15 feet and 25 feet from the lower end of the line. Two sandbags are attached to the outer cut-splice of each line and a single bag to the inner splice, as shown in figure 20. These snubbers give a shock absorber action.

SECTION IV

MIDSHIP MOORING

■ 73. GENERAL.—*a.* In the past, when lack of space prevented the use of tail-line mooring, mooring-circle close-

haul was recommended. Though this method has been partially satisfactory, the need for a speedier, less complicated method requiring fewer men has been recognized. As a result, midship mooring has been evolved.

b. It is suggested that as new balloons arrive in the field for use on sites currently equipped for mooring-circle close-haul, both balloons and sites be rigged for midship mooring, since midship mooring has the following advantages over mooring-circle close-haul:

(1) It requires less time for mooring and flying the balloon.

(2) It permits the balloon to swing with the wind over a wider arc, to ride more satisfactorily in gusty winds, and to be turned more easily in event of a sudden shift in wind direction.

(3) It reduces the size of the crew required by two men.

c. In midship mooring, as in tail-line mooring, the junction assembly of the balloon is attached to the pyramid and safety stop, and the rip cord is transferred from the flying cable to the rip cord stop. The tail of the balloon is moored at the 37-foot circle by a running line, trolley assembly, and a cable track, which function in a manner similar to the tail-line assembly, tail-line bungee assembly, and tail-line mooring-circle cable of tail-line mooring. (See fig. 21.)

d. Site equipment required for midship mooring includes the pyramid with safety and rip cord stops, a mooring-circle cable track and track stops, a trolley assembly, a handy-billy, and two handling-line bags. Special rigging on the balloon is also required.

■ 74. RIGGING ON BALLOON.—On each side of the balloon the rigging consists of a front midship patch, a rear midship patch, a wire bridle grommet, and a wire bridle. A wire running line connects the bridles.

a. *Patches.*—(1) *Front midship patches.*—Each front midship patch on the balloon is placed 16 inches in front of and 5 inches below No. 3 rigging patch. It is placed with the center axis of the patch parallel to a line drawn through the bottom of the rigging patches (see fig. 22). Each front midship patch carries a sector ring.

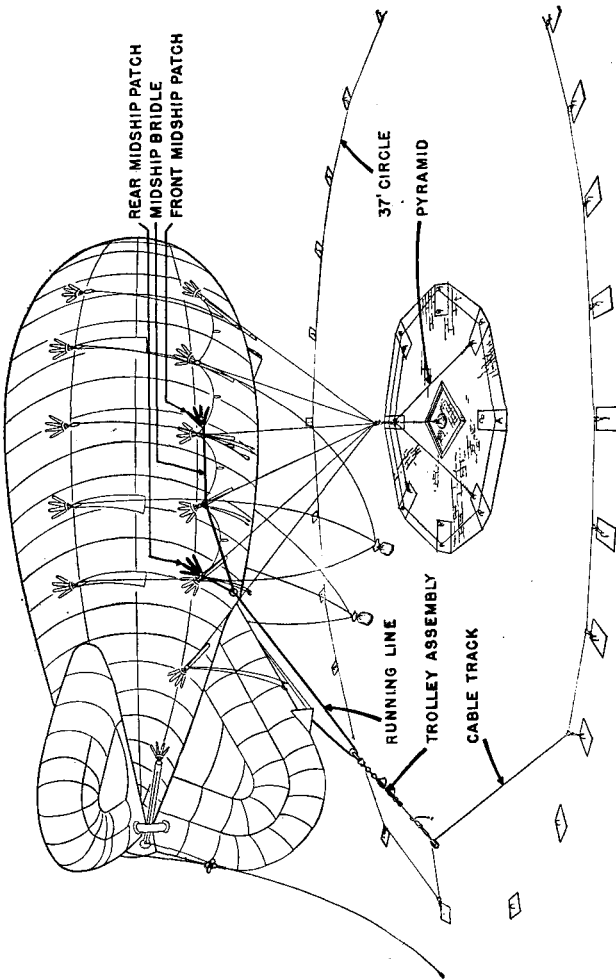

FIGURE 21.—Balloon at midship mooring.

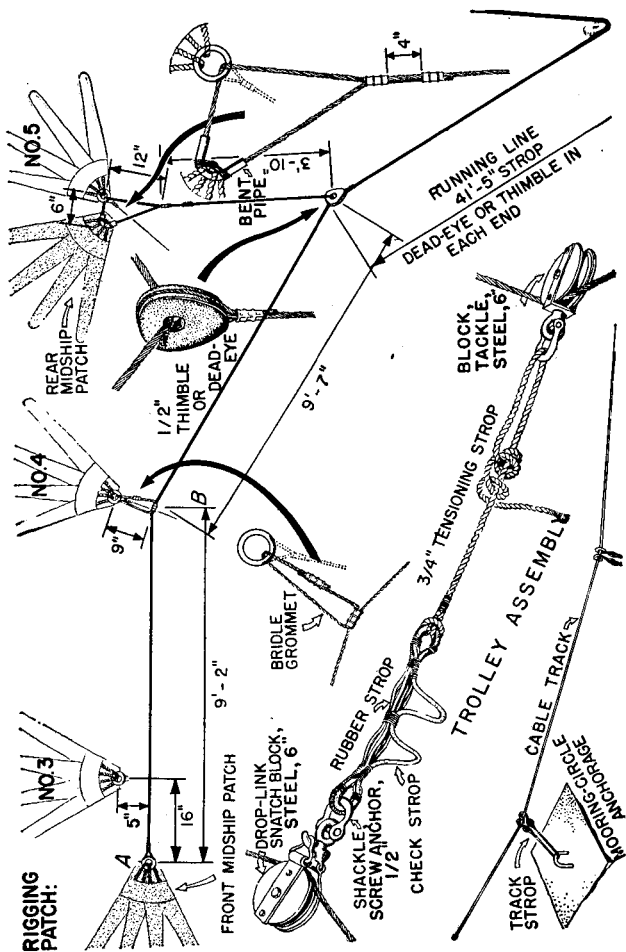

FIGURE 22.—Midship mooring equipment.

(2) *Rear midship patches.*—Each rear midship patch is placed with the center of the bottom of the patch 6 inches ahead of the center of the bottom of No. 5 rigging patch, so that the new patch appears to be a rotation forward of No. 5 rigging patch (see fig. 22). Instead of a sector ring, a $\frac{3}{8}$ -inch iron pipe, 6 inches long and bent to an angle of 60° , is placed in the junction of the midship patch ropes and seized into place. The ends of the pipe are turned toward the No. 5 patch.

b. Bridle grommets.—(1) *Definition.*—The bridle grommet is a short piece of cable made into a 9-inch loop by passing it through the eye of the sector ring of No. 4 rigging patch and clamping the ends together (see fig. 22).

(2) *Installation.*—The bridle grommet is installed, one on each side of the balloon, by looping 1 foot 8 inches of wire rope through the eye of the sector ring of No. 4 rigging patch and clamping the ends together with a nicopress sleeve. A second nicopress sleeve is slipped onto the grommet and left loose when the ends of the grommet are clamped. For details of nicopress sleeve (see FM 4-196 (when published)).

c. Bridles.—(1) *Location.*—A wire cable bridle is rigged from the front midship patch to the rear midship patch on each side of the balloon.

(2) *Installation.*—Each bridle is started at the forward midship patch, carried around the sector ring, and clamped to itself by a nicopress sleeve. It is then run through the loose nicopress sleeve on the bridle grommet (see fig. 22), through a thimble on the end of the running line, through the bent pipe on the rear midship patch, and finally through the eye of the sector ring on No. 5 rigging patch. The running end then is clamped to its standing part 12 inches below the sector ring of No. 5 patch by two nicopress sleeves 4 inches apart. The bridle is tensioned by pulling on the cable until the distance between the forward midship patch and the bridle grommet (points *A* and *B*, fig. 22) is 9 feet 2 inches. After this adjustment, the nicopress sleeve attaching the bridle to the bridle grommet is clamped tight.

NOTE.—The installation and adjustment of the bridle should be made after the balloon is inflated.

d. Running line.—(1) *Definition.*—The running line is a wire cable (41 feet 5 inches long for the D-8 balloon, 39 feet 5 inches for the D-7) passing under the balloon and connecting the two bridles (see fig. 21).

(2) *Installation.*—The running line passes under the balloon in front of the rudder air-scoop and hangs loosely when the balloon is flying. Each end of the line terminates in an eye formed with a nicopress sleeve around a ½-inch thimble. The bridle passes through the eye of the thimble so that the bridle supports the running line behind No. 4 rigging patch.

■ 75. RIGGING ON BED.—The balloon bed used for midship mooring is the standard bed without the tail-line mooring circle.

a. Pyramid.—The pyramid is shackled onto the junction strop of the balloon, as described in tail-line mooring (see par. 63).

b. Mooring circle.—(1) *Cable track.*—A cable track is fastened onto the 37-foot mooring circle anchorages by track strops.

(2) *Track strops.*—Track strops are 1-foot 10-inch wire strops with a small ground rigging hook in each end. Eyes are formed in the ends of each strop with nicopress sleeves.

(3) *Securing cable track.*—A track strop is reeved through the bent rod of each 37-foot mooring-circle anchorage. Both ends of 21 consecutive track strops are hooked onto the cable that is to become the track. The cable is pulled hand tight and secured with a wire rope clip. Then, with the use of the handy-billy, the twenty-second track strop is secured to the track, the cable being allowed to slip in the wire rope clip if necessary, but still being kept taut. The junction of the cable is secured with 2 nicopress sleeves 4 inches apart and the ends of the cable are trimmed back to the sleeves. The wire rope clip is removed and the cable is allowed to lie on the ground with 2 points always unhooked. The junction in the cable track lies under the flying cable.

c. Trolley assembly.—(1) *Definition.*—The trolley assembly consists of the blocks, strops, and shock absorbing devices used to attach the running line to the cable track. The com-

ponent parts are the running-line snatch block and shackle, the rubber strop and the check strop, the midship tensioning strop, and the trolley block and shackle. (See fig. 22.)

(2) *Running-line snatch block.*—A 6-inch, drop-link snatch block rides on the running line when the balloon is moored. It is attached to the rubber strop and check strop by a shackle. It is removed from the running line when the balloon is to be flown.

(3) *Rubber strop.*—The rubber strop is made of 10 strands of $\frac{5}{16}$ -inch rubber cord constructed in the same manner as the tail-line bungee strop described in FM 4-196 (when published). A 1-inch thimble is served into an eye at each end of the rubber strop and the finished, contracted length, from crown to crown of thimbles, is 24 inches.

(4) *Check strop.*—The check strop is 3 feet 4 inches long with a soft eye in each end, and is made of $\frac{1}{2}$ -inch manila rope or equivalent.

(5) *Midship tensioning strop.*—The midship tensioning strop is 7 feet long with a soft eye in one end and with the other end served. It is made of $\frac{3}{4}$ -inch manila rope, or equivalent.

(6) *Trolley block.*—The 6-inch trolley block rides on the cable track.

(7) *Fitting trolley assembly.*—To fit the trolley assembly, a shackle is first attached to the running-line snatch block. One eye of the rubber strop is put on the shackle; then one eye of the check strop is slipped on beside the rubber strop eye and served into place. The soft eye of the tensioning strop next is lark's-headed on the lower eyes of the rubber and check strops. The other end of the tensioning strop is passed through the shackle on the trolley block and tied with a picketing hitch.

■ 76. ADJUSTING THE CABLE TRACK.—To permit the trolley block to ride back and forth, thereby allowing the balloon to shift with the wind, the cable track remains detached from two down wind points on the 37-foot mooring circle. When a shift in wind warrants it, the trolley block is switched by opening one or more points in the direction of the wind shift and closing an equal number of points.

CHAPTER 5

OTHER SITE INSTALLATIONS AND SITE MAINTENANCE

SECTION I. Buildings, gas cylinder stacks, and local defenses_	Paragraphs 77-98
II. Maintenance of site.....	99-116

SECTION I

BUILDINGS, GAS CYLINDER STACKS, AND LOCAL DEFENSES

■ 77. CREW QUARTERS.—The nature of barrage balloon operations requires that the crew be housed on or near the site. Whenever facilities are not available close by, quarters must be constructed for sleeping, messing, and recreation. They preferably should be not less than 75 feet nor more than 150 feet from the tail-line mooring circle.

■ 78. CONSTRUCTION.—It is suggested that the crew quarters be 48 feet long and 20 feet wide and made of prefabricated material to facilitate dismantling and relocating if the site is moved.

■ 79. EQUIPMENT.—*a.* Equipment will include double bunks or steel cots, clothes shelves and poles, a space heater, a coal box where needed, a stove for cooking, food storage shelves, a food preparation counter, two mess tables, a sink, a dish storage, a rifle rack, and sanitary facilities.

b. If connections with public water and sewer lines are possible, the quarters should include a faucet for drinking water, two lavatories, a toilet, a urinal, a shower, and a hot water heater. If public water and sewer connections are not available, a latrine will have to be built outside the quarters, but it still is advisable for the quarters to contain personal washing and drinking facilities and a shower attached to a barrel water supply on a platform. Drinking water should be stored in a barrel or other large container; and it may be well for the men to keep canteens filled for

emergencies, the water in the canteens being changed every day. Electricity should be used for lighting wherever possible; otherwise, lanterns or lamps will be required.

■ 80. LATRINE.—If a toilet is not at hand, it is imperative that a latrine be constructed immediately on the crew's arrival. For construction details see FM 4-198 (when published) or FM 8-40.

■ 81. GARBAGE DISPOSAL.—If garbage is not collected by a public or private agency, it may be necessary to dispose of refuse on the site. For details on incinerators, see FM 8-40.

■ 82. OPERATIONS HUT.—On each barrage balloon site it is necessary to have a building where the telephone is manned 24 hours a day, where all logs and records are maintained by the balloon chief, and storage space is provided for extra equipment. This building is known as the operations hut.

■ 83. LOCATION.—The hut must be within a few feet of the 90-foot mooring-circle and placed so as to allow a full view of the bed through a window facing the central anchorage. When site space is at a premium, the hut may be constructed in combination with the winch shelter.

■ 84. CONSTRUCTION.—The hut should be at least 12 by 16 feet and, if possible, constructed of prefabricated material to facilitate relocation if the site is moved (see figs. 23 and 24).

■ 85. EQUIPMENT.—The hut should contain a desk placed just inside a window facing the central anchorage, a large bulletin board, a work bench, a space heater, a fire extinguisher, a tool chest, a rifle rack, lighting fixtures, tackle brackets, and shelves and pegs for the storage of extra equipment.

■ 86. STORAGE.—It is important that all extra equipment needed on the site be properly labeled and kept in a definite place in the operations hut. Equipment to be stored will include inflation apparatus, lethal devices, mooring slips, tensioning slips, upper cradle slips, lower cradle slips, handling lines, sandbag lines, extra sandbags, grommets, toggles, running nose line, bedding strops, central anchorage cushion, rudder protection sheet, fin-furling lines, block and tackle,

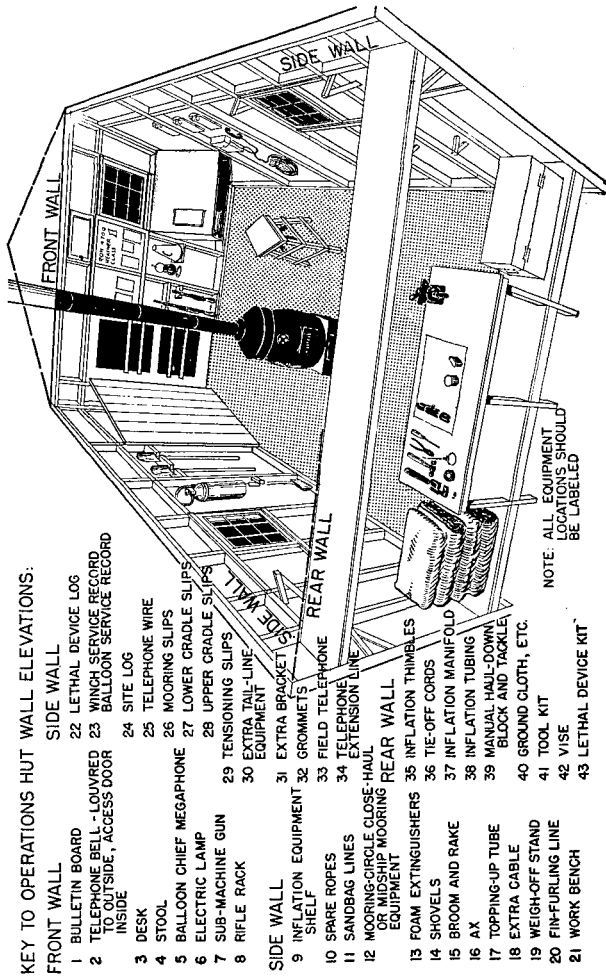

FIGURE 23.—Operations hut,

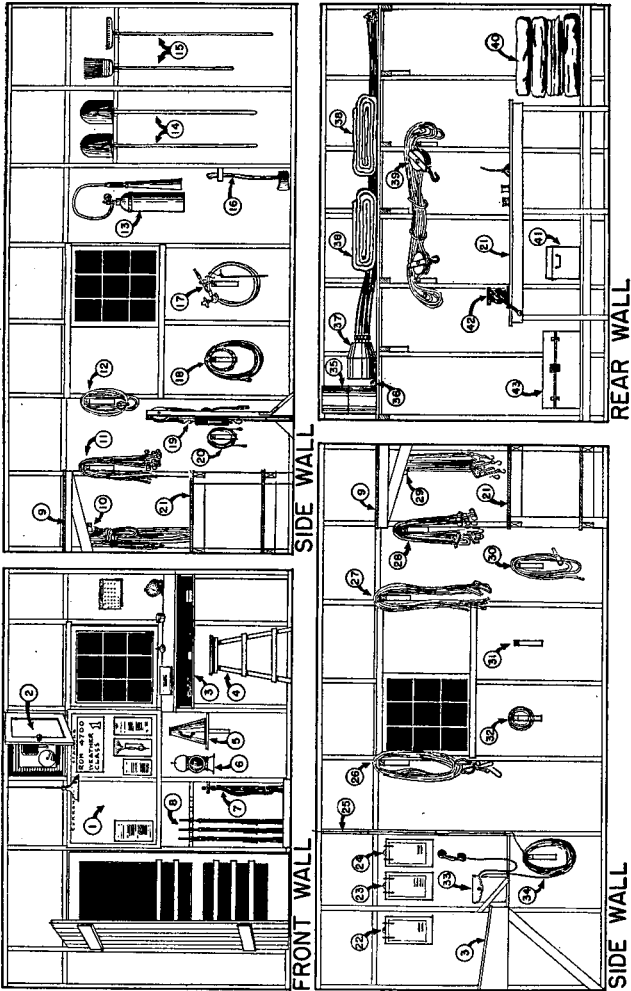

FIGURE 24.—Walls of operations hut.

weigh-off stand, topping-up tube, extra ground cloths, tools, and other bed and site equipment.

87. WIND SAIL.—The wind sail should be placed on the site so as to give an accurate indication of the wind direction. In some cases it may be possible to place the wind sail on top of the operations hut.

88. LOCATION OF GAS CYLINDER STACKS.—The gas cylinder stacks should be accessible by truck, and preferably located on the side of the inflation appendix of the balloon, as the balloon nose faces the prevailing wind. The stacks should be about 10 feet outside the 90-foot mooring circle.

89. PREPARATION.—The lower row of cylinders should be placed on 2- by 6-inch wooden runners or prepared concrete dunnage, with each cylinder chocked with wooden blocks to prevent sidewise motion. The cylinders should be stacked 13 on the bottom row, with the stack not over 6 tiers high and containing a total of not more than 63 cylinders (see fig. 25). When two or more stacks are made, they should be at least 10 feet apart.

90. GROUNDING.—The bottom row of cylinders should be grounded with copper tape 1 inch by $\frac{1}{8}$ inch by 15 feet (or equivalent) attached to a zinc-coated iron grounding rod $\frac{3}{4}$ inch by 6 feet (or equivalent) driven at least 4 feet into the ground.

91. CYLINDER CARE.—Cylinders should be stacked with valve outlets turned down. The stacks should be covered with tarpaulin, removable wooden sheds, or other suitable material to offer protection from direct rays of the sun. All safety precautions relating to hydrogen should be observed. (See FM 4-187.)

92. LOCAL DEFENSES.—Combat efficiency of a unit is dependent on its morale almost as much as on its technical proficiency. In combat zones, morale tends to drop as casualties rise. Consequently, in construction of balloon sites.

it is necessary to establish some form of shelter for the men in event of air or ground attack. The building of such shelters is a function of the occupying troops and should be carried out at the earliest opportunity.

■ 93. L-SHAPED FOX HOLES.—*a.* Reports from combat areas indicate that several L-shaped fox holes scattered around the site afford the most satisfactory protection against bombing or strafing attacks. The resulting dispersion of manpower is extremely desirable since a single bomb hit is less likely to effect the entire site personnel. The L-shape prevents enfilading during a strafing attack if crewmen take shelter in the leg of the L perpendicular to the line of attack.

b. The size and terrain of the individual sites naturally will govern the exact location of the defenses. It is suggested, however, that at least three fox holes be placed about the bed approximately as an equilateral triangle, in order to obtain dispersion of the crew. They should be located so that the men can reach them quickly and still be in position to operate the winch, if necessary, and guard against attack from paratroops or ground troops.

c. One fox hole should be within 15 feet of the winch and in line with the opening in the winch barricade, if a barricade is present, or with the operator's seat if there is no barricade. A second fox hole should be near the operations hut and within easy access of the door. A third should be across the bed from the winch. If crew quarters are on the site, a fourth should be close to the quarters. Any of these fox holes could be used in conjunction with a machine-gun emplacement, if one is located on the site.

■ 94. ASSIGNMENT.—To avoid confusion, each squad member should be definitely assigned to a fox hole.

■ 95. FOX HOLE CONSTRUCTION.—The fox holes should be about 18 inches wide, about $4\frac{1}{2}$ to 6 feet deep, and with each leg of the L at least 8 feet long (see fig. 26). Steps should be dug on each end to facilitate entering and leaving. If the fox holes are in soft ground, it may be well to brace them. The dug-out earth should be used as a parapet, which will afford extra protection and at the same time help keep out

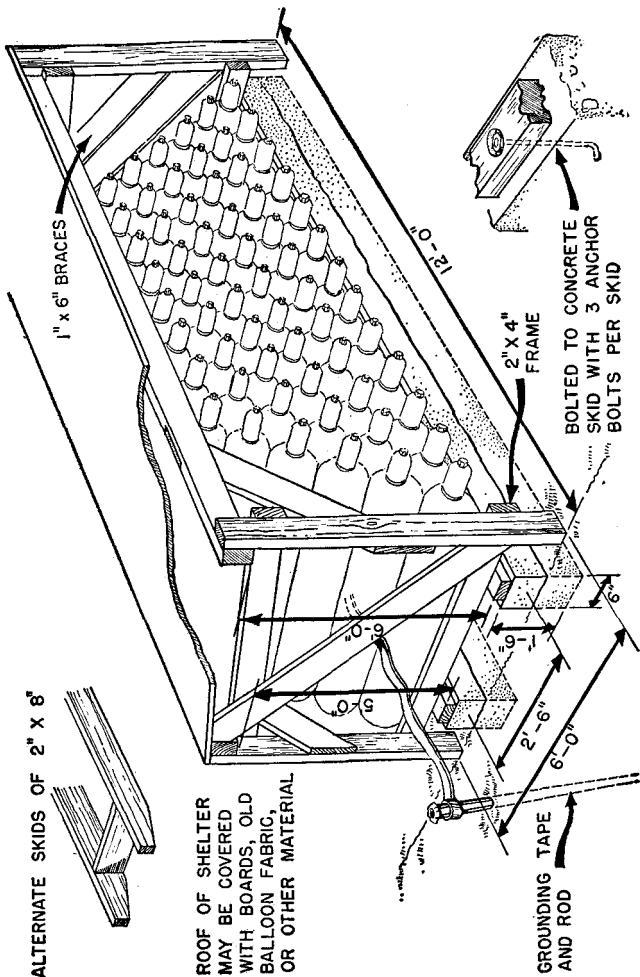

FIGURE 25.—Gas cylinder stack.

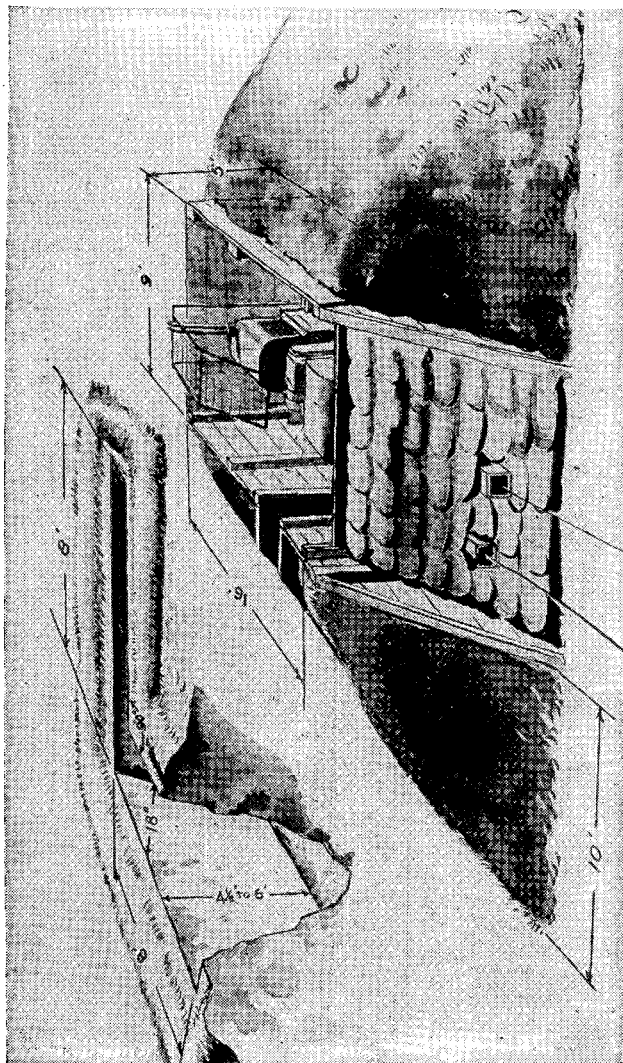

FIGURE 26.—Local defenses.

surface water. To drain off water which may fall directly into the fox hole, use either of the following methods: On the low side of the fox hole place a wooden flume, carrying into a ditch or hollow; or slope the bottom of the fox hole and on the low side dig a deep sump, filling it with loose rock, gravel, or similar material.

■ 96. **INDIVIDUAL FOX HOLES.**—On some sites, individual fox holes may be advisable for use against ground attack. For construction details, see FM 21-45.

■ 97. **WINCH PROTECTION.**—Damage to the winch will immobilize the balloon and therefore it is essential that some type of protection be provided. One suggested shelter for the winch consists of a plank wall about 9 by 16 by 5 feet, surrounded on three sides by an earth embankment sloping up from a point about 10 feet out from the wall (see fig. 26). On the fourth side, facing the bed, is a removable wooden panel, fronted by sandbags sloping up to the top of the wall. Rectangular wooden tunnels provide passage for the flying cable and for the hauling cable leading to the gipsy-head. A narrow entrance for the winch operator is on one side of the shelter. The winch anchorage should be installed before the shelter is built.

■ 98. **CAMOUFLAGE.**—The fox holes and the winch barricade should be camouflaged whenever possible. Either natural or artificial materials or combinations of both may be used, but the results should blend with the appearance of the immediate vicinity. Chicken wire, nets, burlap or burlap substitute, paints, and lumber are some of the artificial materials which may be used on occasion to supplement natural materials. For more detailed information on camouflage see FM 21-45 and FM 5-20.

SECTION II

MAINTENANCE OF SITE

■ 99. **CARE.**—Site equipment at all times should be kept in the best of condition, since faulty equipment means faulty operations.

■ 100. CABLE.—All cable used on the bed must be kept free from dirt and rust by frequent inspection, cleaning, and application of new engine oil. For further information on cable repair, treatment, and storage, see FM 4-187.

■ 101. ROPE, SLIPS, AND GROMMETS.—All equipment made of rope should be inspected frequently and kept clean and dry. If wet, it should be hung up and allowed to dry naturally, avoiding the application of artificial heat. Care should be taken to prevent the freezing of wet ropes. Wet rope equipment should never be stored until dried. To test rope, it should be twisted open, and loose fibers, dampness, or flakiness noted. Markings on handling lines should be checked after each rainy spell and, if necessary, moved. Worn rope naturally should be replaced at once. For detailed information on rope, see FM 4-196 (when published).

■ 102. ADJUSTING BLOCKS AND TOGGLES.—All equipment made of wood should be checked frequently for splits or other defects.

■ 103. HOOKS ON SLIPS.—Hooks should be maintained clean and free from rust and kept either painted or oiled.

■ 104. GROUND CLOTHS.—When ground cloths are not needed, they should be dried, if necessary, folded, and placed in the operations hut.

■ 105. ANCHORAGES.—All metal work on anchorages should be oiled or painted and kept free from rust or dirt. Frequent anchorage inspections should be made for damage or undermining by erosion.

■ 106. METAL BLOCKS.—Metal blocks should be cleaned frequently to prevent accumulation of rust or dirt, and the moving parts should be kept oiled. Frames should be painted. When the blocks are not in use, it is best to protect them with fabric covers.

107. SPIDERS.—Frequent inspections should be made to see that eyes of the spiders are well served, since worn serving makes for unnecessary wear on the handling lines.

108. SANDBAGS.—Sandbags should be frequently weighed to insure the correct quantity of sand. They should be checked for rips and for dampness and when wet should be dried. Care should be taken to avoid dropping the bags, since this shortens their life.

109. HANDY-BILLY.—When not in use the handy-billy should be placed on top of a tail-line mooring-circle post. It should be kept clean and oiled. The blocks should be painted, and the rope frequently checked for wear.

110. TAIL-LINE BLOCK.—The tail-line block should be subject to the care applied to all metal blocks (see par. 106), but in addition, should have a fabric cover on at all times.

111. SHACKLES.—Shackles should be kept free from dirt and rust and should be oiled to facilitate freedom of movement. A check should be made for bent pins.

112. GROUNDING MAT.—The grounding mat should be inspected for general condition and should be kept free from mud.

113. GRASS.—Grass is desirable on that part of the bed which is not paved or graveled, but it should be kept free from weeds and brush that would impede handling of the balloon.

114. DRAINAGE.—Care must be taken to keep the bed and site well drained at all times.

115. DEADMEN.—Deadmen once installed will not last indefinitely and frequent inspections should be made for deterioration of wood and corrosion of cable.

a. *Care of wood.*—Creosote or some other protective material will help prolong the life of the deadmen.

b. *Care of cable.*—For protection of cable several commercial products are available. They are usually applied by

painting, dipping, or spraying, and are reported highly resistant to acid, alkaline, or sea water. The length of time cable will last depends upon the type of soil and atmospheric conditions. Experience indicates that in salty soil it is necessary to replace all nontreated cable by the end of the third or fourth month.

■ 116. STORAGE.—Adequate storage space is needed on the site for all extra site equipment. (See par. 86.)

APPENDIX I

DUMMY SITES

■ 1. PURPOSE.—*a.* Dummy installations are intended primarily to confuse the enemy as to the location of the target or targets and the strength of the barrage, but also may give some protection to personnel by distracting strafing airplanes.

b. A dummy should be made to look exactly like a real bed from the air, so far as this is possible. If the roof of a building is used, it may be possible to paint the bed in, but on the ground much of the earthwork necessary for a real site will be required. Painted boards for anchorages, scattered blocks, and a winch faked from boards may be employed. Whenever possible, experts on camouflage should be consulted before dummy sites are constructed.

■ 2. USING OLD BALLOONS.—The illusory value of dummy sites, particularly in open areas, will be increased considerably if old balloons, no longer fit for actual flying but suitable for air inflation, are placed on the beds, inflated, and moored. Dummy beds holding such balloons naturally will have to be constructed with this function in view.

■ 3. MOORING OLD BALLOONS.—*a.* The balloons, minus rudder and fins or with rudder and fins furled, should be air inflated, bedded down in the direction of the prevailing wind, and left pointing that way regardless of subsequent shifts in wind. One suggested method for bedding down is to lay out a 37-foot circle of 24 screw pickets and secure the balloon with handling, mooring, and nose mooring lines (see fig. 27). No octagon or cradle bed is required.

b. The procedure is as follows:

(1) The 37-foot circle should be laid out.

(2) Ground cloths should be placed in the middle of the bed and four 50-foot lengths of $\frac{1}{2}$ -inch rope laid out.

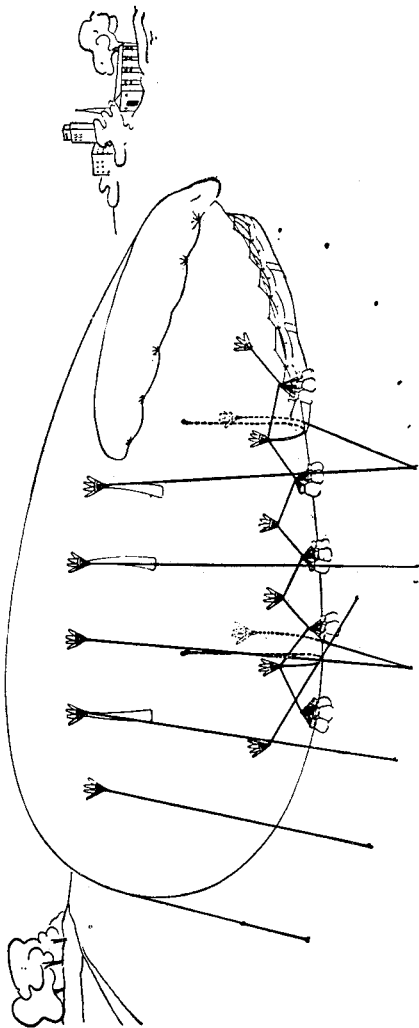

FIGURE 27.—Mooring old balloon on dummy site.

BARRAGE BALLOON SITE INSTALLATIONS

(3) The balloon then should be laid out, with nose to the prevailing wind, and a cradle formed by running the $\frac{1}{2}$ -inch rope from the Nos. 2 and 5 rigging patches on the left side underneath the balloon to the pickets on the 37-foot circle on the right side, and similarly from the Nos. 2 and 5 rigging patches on the right side to the pickets on the left side.

(4) Air inflation should begin, with the gas valve line buckle being moved about 20 inches in from the gas setting, toward the gas valve.

(5) The handling, mooring, and nose mooring lines meanwhile should be rigged to the 37-foot circle.

(6) Then, to prevent the balloon from moving forward, a length of $\frac{1}{2}$ -inch rope on each side of the balloon should be rigged to the No. 1 rigging patch, run outward and toward the tail, and made fast to screw pickets placed 3 feet out from the No. 3 rigging patch.

(7) Four sandbags should be tied together by the loops and hung across the rigging line between rigging line patches.

(8) Inflation should continue with the handling, mooring, and nose mooring lines and sandbags being adjusted until all are subjected to a light strain with the gas valve blowing off.

(9) All knots should be secured, with no subsequent cordage adjustments made except when topping-up with the air blower or when the valve is blowing off. Slack cordage indicates topping-up is needed. When deemed advisable, extra sandbags may be hung on rigging lines and bedding strops.

■ 4. MAINTENANCE.—Adequate personnel should be assigned to dummy balloons, both to protect matériel and to top-up or perform other servicing as needed.

APPENDIX II

LIST OF REFERENCES

Organization and Tactics.....	FM 4-181 (to be published)
Service of the Balloon and Balloon Equipment, Low Altitude.	FM 4-187
Rigging and Fabric Repair.....	FM 4-196 (to be published)
Reference Data.....	FM 4-198 (to be published)
Communications, Construction, and Utilities.	FM 5-10
Field Fortifications.....	FM 5-15
Camouflage.....	FM 5-20
Reference Data.....	FM 5-35
Field Sanitation.....	FM 8-40
Protective Measures, Individuals, and Small Units.	FM 21-45

INDEX

	Paragraph	Page
Access road:		
Construction -----	12	9
Maintenance -----	15	9
Parking space near -----	16	9
Quality -----	13	9
Turn-outs -----	14	9
Airport sites -----	8	6
Anchorage:		
Permanent:		
Central -----	27	12
Fair-lead -----	33	19
General requirements -----	23	11
Hauling -----	33	19
Main point -----	31	17
Mooring-circle -----	32	19
Tail-line mooring-circle -----	34	19
Winch -----	39	22
Temporary:		
Central -----	28-30	15
Hauling -----	35	20
Main point -----	35	20
Mooring-circle -----	35	20
Tail-line mooring-circle -----	35	20
Winch -----	40-42	22
Assembly, trolley -----	75	55
Bag, handling line -----	64, 73	43, 50
Ballast blocks, extra -----	57	36
Ballast, cradle -----	51	30
Ballonet type balloon, characteristics -----	4	1
Balloon:		
Ballonet type -----	4	1
Old -----	App. I	69
Securing -----	5	3
Bed:		
Definition of -----	3	1
Steps in laying out -----	26	12
Surfacing -----	36	21
Bed blocks:		
Attachment of in bedding down -----	46	26
Use in mooring-circle close-haul -----	71	48
Bedding down -----	44-57	26
Characteristics of equipment -----	6	4
Necessity -----	44	26
Bedding strops -----	52	32
Extra -----	57	36
Block, central anchorage -----	27	12
Block, trolley -----	75	55

INDEX

	Paragraph	Page
Blocks:		
Bed:		
Attachment of in bedding down.....	46	26
Use in mooring-circle close-haul.....	71	48
Ballast.....	51	30
Bridle grommet.....	74	51
Bridle, wire.....	74	51
Bungee assembly, tail-line.....	67	46
Bungee stop.....	67	46
Bypass, tail-line mooring-circle.....	68	46
Cable:		
Hauling.....	33	19
Tail-line mooring-circle.....	59	38
Track for midship mooring.....	75	55
Camouflage, site.....	98	65
Central anchorage:		
Construction of concrete type.....	27	12
Construction of temporary type.....	28, 29	15
Grounding equipment.....	27	12
Rod.....	27	12
Check stop:		
For tail-line mooring.....	67	46
For midship mooring.....	75	55
Close-haul, mooring-circle.....	5, 6, 69-72	3, 4, 48
Concrete:		
Suggested mix of.....	24	11
Use for anchorages.....	23	11
Cradle:		
Ballast.....	51	30
Extension stop.....	51	30
Legs.....	51	30
Lines.....	52	32
Slips:		
Extra upper.....	57	36
Lower.....	52	32
Upper.....	52	32
Cradle bed, definition.....	32	19
Crew quarters:		
Construction.....	78	57
Equipment.....	79	57
Garbage disposal equipment.....	81	58
Latrine.....	80	58
Curb, central anchorage.....	27	12
Deadman central anchorage:		
Construction.....	29	15
Grounding.....	30	17
Deadman winch anchorage:		
Construction.....	41	22
Grounding.....	42	25
Defenses, local.....	92-98	61
Dummy sites:		
Construction.....	App. I	69
Mooring old balloons.....	App. I	69
Purpose.....	App. I	69
Use of old balloons.....	App. I	69

INDEX

	Paragraph	Page
Earthwork:		
Clearing site.....	18	10
Grading site.....	19	10
High water marks.....	20	11
Equipment:		
Additional for storm precautions.....	57	36
Features of handling.....	6	4
Manual haul-down.....	50	30
Fins, furling.....	56	36
Flying, types.....	38	22
Fox holes.....	93-96	62
Assignment of men.....	94	62
Construction.....	95	62
Location.....	93	62
Front midship patch.....	74	51
Furling rudder and fins.....	56	36
Garbage disposal equipment for site.....	81	58
Gas cylinder stacks:		
Care.....	91	61
Grounding.....	90	61
Location.....	88	61
Preparation.....	89	61
Gipsy-head.....	33	19
Grading of site.....	19	10
Grommet, bridle.....	74	51
Grommets, wire.....	46	26
Grounding mat, central anchorage.....	27	12
Grounding plate:		
Central anchorage.....	27	12
Winch anchorage.....	39	22
Handling equipment, general features.....	6	4
Handling-line bag.....	64, 73	43, 50
Handling lines:		
Attaching front in mooring-circle close-haul.....	72	50
Attaching to wire spider.....	48	28
Marking.....	48	28
Reeving and tying rear in mooring-circle close-haul.....	71	48
Handy-billy.....	62, 73	42, 50
Haul-down:		
Manual.....	49, 50	30
Mechanical.....	49	30
Hauling anchorage, construction.....	33	19
Latrine.....	80	58
Laying out bed, steps.....	26	12
Line, running.....	74	51
Lines:		
Cradle.....	52	32
Sandbag.....	53	35
Local defenses:		
Camouflaging.....	98	65
Fox holes.....	93-96	62
Winch barricade.....	97	65

INDEX

	Paragraph	Page
Main points:		
Construction	31	17
Plane	31	17
Maintenance of site equipment	99-116	65
Manual haul-down	49	30
Equipment	50	30
Mechanical haul-down	49	30
Midship mooring	5, 6, 73-76	3, 4, 50
Advantages	73	50
Characteristics of equipment	6	4
Midship tensioning strop	75	55
Mooring circle, radius	32	19
Mooring-circle anchorages, construction	32	19
Mooring-circle close-haul	5, 6, 69-72	3, 4, 48
Characteristics of equipment	6	4
Mooring-line extensions	57	36
Mooring, midship	5, 6, 73-76	3, 4, 50
Mooring slips	54	35
Occupation of site:		
Procedure for when site fully prepared	10	7
Procedure for when site partially prepared	11	8
Octagon	31	17
Old balloons:		
Maintenance	App. I	69
Mooring	App. I	69
Tactical use	App. I	69
Operations hut:		
Construction	84	58
Equipment stored	86	58
Location	83	58
Parking space	16	9
Patches, midship	74	51
Pickets, screw	35	20
Point of attachment	45	36
Post, tail-line mooring-circle	60	40
Pyramid	63	42
Quarters, crew	77-81	57
Quick release shackle	63	42
Rear midship patch	74	51
Rigging, tail-line	66, 67	43, 46
Rigging-line sandbags	53	35
Rip cord strop	63	42
Rods, anchorage	27, 31-34, 39	12, 17, 22
Rubber strop	75	55
Rudder, furling	56	36
Running line, wire	74	51
Running-line snatch block	75	55
Running tensioning slip	71	48
Safeguarding property	21	11
Safety strop	63	42
Sale, wind	87	61

INDEX

	Paragraph	Page
Sandbag—		
Lines.....	53	35
Spider.....	72	50
Weight.....	51	30
Sandbags:		
Extra.....	57	36
Rigging-line.....	53	35
Securing balloon:		
Basic considerations.....	4	1
Methods.....	5	3
Shackle, quick release.....	63	42
Shelter for—		
Crew.....	92-96	61
Winch.....	97	65
Site:		
Airport.....	8	6
Auxiliary installations.....	2	1
Definition.....	2	1
Dummy.....	App. 1	69
Earthwork.....	17-19	9
Grading.....	19	10
High water marks.....	20	11
Occupation.....	10, 11	7, 8
Sites:		
Ratio.....	9	7
Types.....	8	6
Urban.....	8	6
Site equipment, maintenance.....	99-116	65
Slip, running tensioning.....	71	48
Slips:		
Extra upper cradle.....	57	36
Lower cradle.....	52	32
Mooring.....	54	35
Tensioning.....	55	35
Upper cradle.....	52	32
Snatch block:		
Running-line.....	75	55
Tail-line.....	67	46
Snubbers.....	72	50
Space, parking.....	16	9
Spider, sandbag.....	72	50
Spider, wire.....	47	26
Attaching handling lines.....	48	28
Steel equipment.....	22	11
Stepladder for fin furling.....	56	36
Storm precautions, extra equipment.....	57	36
Strop:		
Bedding.....	52	32
Bungee.....	67	46
Check.....	67	46
Rip cord.....	63	42
Rubber.....	75	55
Safety.....	63	42
Tail-line.....	67	46
Tail-line mooring-circle.....	61	40
Tensioning, midship.....	75	55

INDEX

	Paragraph	Page
Strop—Continued.		
Track -----	75	55
Transverse -----	71	48
Surfacing bed -----	36	21
Tail-line—		
Assembly -----	66	43
Bungee assembly -----	67	46
Rigging -----	65	43
Snatch block -----	67	46
Strop -----	67	46
Tail-line mooring -----	5, 6, 58-68	3, 4, 38
Characteristics of equipment -----	6	4
Tail-line mooring-circle -----	34	19
Anchorages, construction -----	34	19
Bypass -----	68	46
Cable -----	59	38
Posts -----	60	40
Strops -----	61	40
Temporary anchorages. (<i>see</i> Anchorages, temporary.)		
Tensioning slips -----	55	35
Tensioning strop, midship -----	75	55
Track, cable -----	75	55
Adjusting -----	76	56
Track strops -----	75	55
Transverse strop -----	71	48
Trolley assembly -----	75	55
Fitting -----	75	55
Trolley block -----	75	55
Types of flying -----	38	22
Urban sites -----	8	6
General classes -----	8	6
Winch anchorage:		
Construction of—		
Concrete type -----	39	22
Deadman type -----	41-42	22
Truck type -----	43	25
Location for—		
Direct flying -----	38	22
Indirect flying -----	38	22
Wind, prevailing:		
Relation to main point -----	26, 31	12, 17
Relation to winch anchorage -----	38	22
Wind sail -----	87	61
Wire bridle -----	74	51
Wire running line -----	74	51
Wire spider -----	47	26



ANTI-AIRCRAFT ARTILLERY FIELD MANUAL

BARRAGE BALLOON SITE INSTALLATIONS

CHANGES
No. 1

WAR DEPARTMENT,
WASHINGTON 25, D. C., 27 March 1944.

FM 4-184, 13 April 1943, is changed as follows:

5. METHODS.—*a.* When the inflated * * * and midship
ring.

(1) Bedding down is securing the balloon close to the ground
by means of ballast so that the air-scoop is just above the
ground, the lowest point of the ballonnet clears the ground by
about 18 inches, and the junction of the rudder and ballonnet
is 3 to 5 feet above the ground. (See fig. 9.) It is stressed
* * * on the ground.

* * * * *

8. TYPES.

* * * * *

b. Urban sites.—Tactical situations will * * * industrial,
and business.

(1) In residential districts, sites may be located in vacant
lots, public parks, golf courses, street intersections, and other
open spaces. If it is necessary to locate balloon sites in school
yards or playgrounds, the civilian population should be ex-
cluded from the occupied areas.

* * * * *

19. GRADING.—After the area * * * the central anchor-
e. (See fig. 2.) It may be necessary to camouflage the
drainage ditch and the outline of the bed in order to fit into
local camouflage plans.

36. SURFACING THE BED.

* * * * *

(Added.) It may be necessary to camouflage the surface of
the bed in order to fit into local camouflage plans.

■ 39. CONCRETE ANCHORAGE.

* * * * *

b. Imbedded in the anchorage are four anchor rods, bent into the shape shown in figure 6. The anchorage should * * * to the winch.

■ 52. CRADLE SLIPS AND LINES.

* * * * *

d. *Bedding strops* (Superseded).—Bedding strops are made of $\frac{3}{8}$ -inch manila rope (or equivalent) with a soft eye in each end. On balloons with delta type rigging patches, the bedding strops are lark's-headed to the foot ropes. On balloons with finger type rigging patches, the bedding strops are lark's-headed into the suspension rings. Two bedding strops are attached at each No. 5 rigging patch, and one strop is normally attached at each of the remaining patches. For storm precautions, an extra bedding strop is attached at every rigging patch except No. 5. The overall lengths of the strops are as follows:

<i>Rigging patch</i>	<i>D-7 or Mk. VII</i>	<i>D-8</i>
Nos. 1 through 4-----	2 feet 6 inches	2 feet 6 inches
No. 5-----	3 feet 9 inches	5 feet
No. 6-----	6 feet	8 feet

■ 56. FURLING THE RUDDER AND FINS.—a. *General*.—When the balloon * * * on the ground. Standard equipment for furling consists of a rudder protection sheet 7 by 26 feet and *tr. fin-furling lines* 38 feet long.

* * * * *

■ 57. ADDITIONAL EQUIPMENT FOR STORM PRECAUTIONS.—In high winds * * * (see fig. 14):

a. (1) For the D-7 balloon, four mooring-line extensions of $\frac{5}{8}$ -inch manila rope (or equivalent), 25 feet long, eye-spliced at one end.

* * * * *

■ 66. TAIL-LINE ASSEMBLY.—a. *Components*.—The tail-line assembly * * * tail-line extension. The tail-line bridle * * * tail line are furnished with the balloon. For dimensions, FM 4-196 or FM 4-198.

BARRAGE BALLOON SITE INSTALLATIONS

■ 67. TAIL-LINE BUNGEE ASSEMBLY.

* * * * *

b. *Tail-line strop*.—The tail-line * * * the upper end. The eye is connected to the tail line by a 14-inch toggle, which is secured to the tail-line strop by a retaining cord. The lower end * * * a picketing hitch. The tail-line strop is tensioned so that the balloon rides at an angle of trim of about 12°.

■ 71. REAR HANDLING LINES.—a. *Bed blocks*.

■ 75. RIGGING ON BED.

b. *Mooring circle*.

* * * * *

(2) *Track strops*.—Track strops are 1-foot 6-inch wire strops with a small ground rigging hook in each end. Eyes are formed in the ends of each strop with nicopress sleeves.

* * * * *

d. *Fitting trolley assembly*.—To fit the * * * a picketing hitch. The tensioning strop is tensioned so that the balloon rides at an angle of trim of about 12°.

* * * * *

■ 77. CREW QUARTERS.—The nature of * * * messing, and recreation. They preferably should be not less than 75 feet nor more than 150 feet up prevailing wind from the tail-line mooring circle, and doors on the side of the quarters facing the balloon bed should be avoided.

* * * * *

■ 81. GARBAGE DISPOSAL (Superseded).—Garbage from the sites should be collected and disposed of at a central location by the platoon, battery, or battalion. Incineration of garbage at the site should not be attempted because of the fire hazard.

■ 81.1. (Added) STERILIZATION OF MESS KITS.—Open fires should not be used at balloon sites to heat water for the sterilization of mess kits. A closed brick or stone fireplace may be constructed on the site to heat water, provided such a fireplace is located not less than 150 feet from the balloon.

ANTI-AIRCRAFT ARTILLERY FIELD MANUAL

■ 87. WIND SAIL.—Rescinded.

■ 108. SANDBAGS. — Sandbags should be * * * shortens their life. The use of clean pea gravel, if available, instead of sand for filling sandbags will help to increase the life of the bags. Capillary dampness does not occur in gravel-filled bags, and these bags dry more quickly after becoming wet.

[A. G. 300.7 (7 Mar 44).]

BY ORDER OF THE SECRETARY OF WAR:

G. C. MARSHALL,
Chief of Staff.

OFFICIAL:

J. A. ULIO,
Major General,
The Adjutant General.