

TM 9-575

WAR DEPARTMENT

TECHNICAL MANUAL



AUXILIARY FIRE-CONTROL
INSTRUMENTS
(FIELD GLASSES, EYEGLASSES,
TELESCOPES, AND WATCHES)

May 4, 1942

**AUXILIARY FIRE-CONTROL INSTRUMENTS
(FIELD GLASSES, EYEGLASSES, TELESCOPES,
AND WATCHES)**

SECTION I. General.	Paragraph
Scope-----	1
II. Field glasses.	
Binocular M3-----	2
Glass, field, type EE-----	3
Glass, field, Huet type, 8-power-----	4
Glass, field, type E-----	5
III. Eyeglasses.	
Eyeglasses, amber, M2-----	6
Eyeglasses, red, M1-----	7
IV. Observation telescopes.	
Telescope, observation, M4-----	8
Telescope, observation, French, 3-power, M1917--	9
V. Time interval recorders.	
General-----	10
Recorder, time interval-----	11
Watch, stop, type B, class 15-----	12
VI. Watches.	
Watch, pocket, 7-jewel-----	13
Watch, pocket, 15 or more jewels-----	14
Watch, pocket, railroad grade-----	15
Watch, wrist, 7-jewel-----	16
Watch, wrist, 15 or more jewels-----	17
VII. Care and preservation.	
Instructions-----	18
APPENDIX. List of references-----	Page 24

SECTION I

GENERAL

Scope-----	Paragraph 1
------------	----------------

1. **Scope.**—*a.* This manual is published for the information and guidance of the using arms and services.

0-030674

PROPERTY OF U.S.

b. In addition to a description of fire-control instruments for general application, this manual contains technical information required for the identification, use, and care of the matériel.

c. Disassembly, assembly, and such repairs as may be handled by using arms personnel will be undertaken only under the supervision of an officer or the chief mechanic.

d. In all cases where the nature of the repair, modification, or adjustment is beyond the scope or facilities of the unit, the responsible ordnance service should be informed in order that trained personnel with suitable tools and equipment may be provided, or proper instructions issued.

e. Instruments described are—

- (1) Binocular M3.
- (2) Glass, field, type EE.
- (3) Glass, field, Huet.
- (4) Glass, field, type E.
- (5) Eyeglasses, amber, M2.
- (6) Eyeglasses, red, M1.
- (7) Telescope, observation, M4.
- (8) Telescope, observation, French, 3-power, M1917.
- (9) Recorder, time interval, classes A and B.
- (10) Watch, stop, type B, class 15.
- (11) Watch, pocket, 7-jewel.
- (12) Watch, pocket, 15-jewel.
- (13) Watch, pocket, railroad grade.
- (14) Watch, wrist, 7-jewel.
- (15) Watch, wrist, 15 or more jewels.

SECTION II

FIELD GLASSES

Paragraph

Binocular M3.....	2
Glass, field, type EE.....	3
Glass, field, Huet type, 8-power.....	4
Glass, field, type E.....	5

2. Binocular M3 (figs. 1 and 2).—*a. Description.*—(1) This is the standard binocular field glass used for observation and approximate measurement of small angles. It has 6-power magnification and an objective pupil diameter of 30 mm.

(2) Binocular M3 consists of two compact prismatic telescopes pivoted about a hinge which provides adjustment for interpupillary

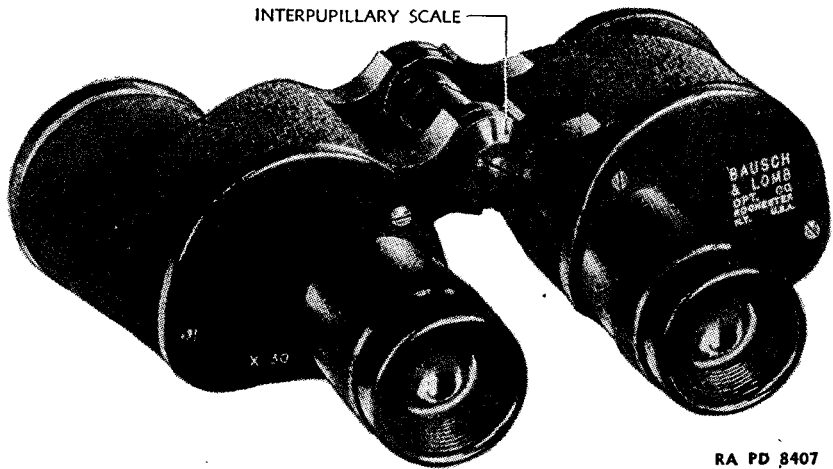

FIGURE 1.—Binocular M3 showing interpupillary scale.

distances varying between 56 and 74 mm. The left telescope contains the reticle.

(3) The reticle (fig. 3) has a horizontal mil scale, graduated at 10-mil intervals and numbered from 50 mils right to 50 mils left of the center of the field of view. Above the horizontal line are two

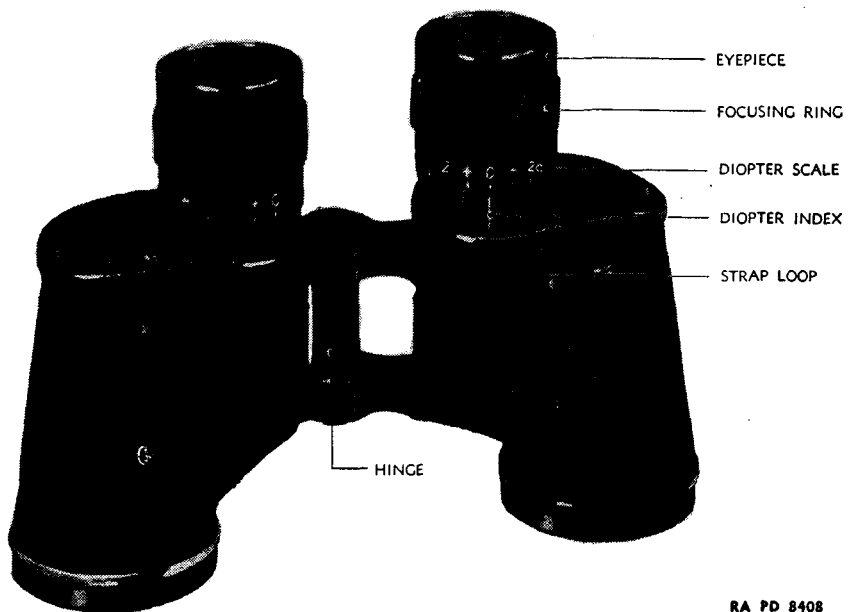
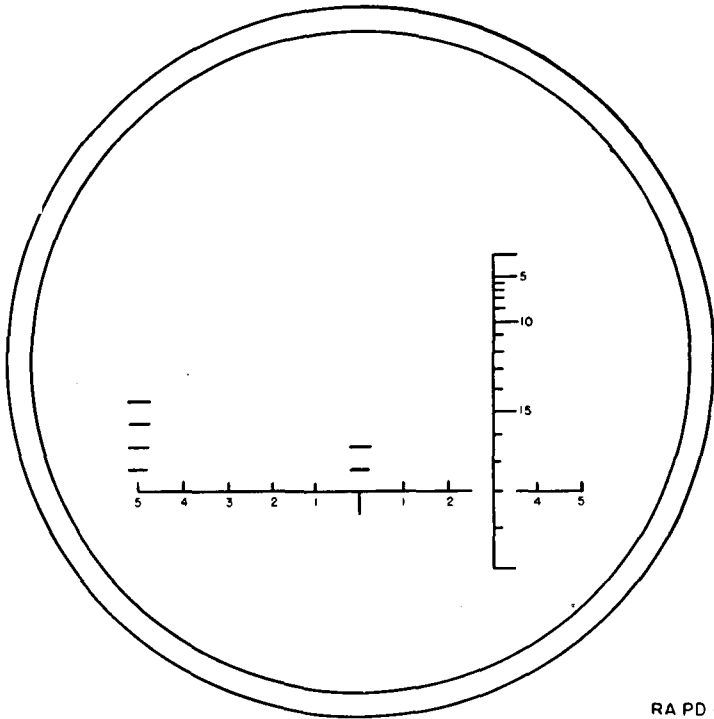

FIGURE 2.—Binocular M3 showing diopter scales.

series of reference marks; these marks are spaced 5 mils apart for convenience in observing fire. The vertical scale, graduated in hundreds of yards, with the 1,800-yard indication in line with the horizontal mil scale, is used by infantry organizations in indirect firing at long range and at invisible field targets.

(4) The neck strap, secured to the strap loops of the instrument, protects the instrument from accidental falls and keeps it within easy reach. A russet leather carrying case, with carrying loop and shoulder



RA PD 4896

FIGURE 3.—Binocular M3, reticle pattern.

strap, protects the instrument when it is not in use. The instrument is carried in the case with the objective end up. When replacing the binocular in the case the diopter scale (par. 3b) setting need not be distributed, but the hinge may need adjusting.

b. Operation.—(1) *Setting interpupillary distances.*—To set the binocular so that the eyepieces are the same distance apart as the observer's eyes, first look through the glass at some fairly distant object, then open or close the glasses at the hinge until the field of view ceases to be separate or overlapping circles and appears to be one sharply defined circle.

(2) *Focusing.*—Look through the eyepieces, both eyes open, at a fairly distant object. Place a hand over the front of one telescope and screw the focusing nut of the other in or out until the object is sharply defined. Repeat for the other eye. Then note the diopter scale reading on each eyepiece; a similar setting of the eyepieces of any other field glass will accommodate the observer's eyes. Avoid touching the objective lens.

(3) *Observing.*—Hold the binocular in both hands, eyepieces pressed lightly to the eyes to avoid transmission of body tremors to the instrument. When possible, use a rest for the binocular or elbows.

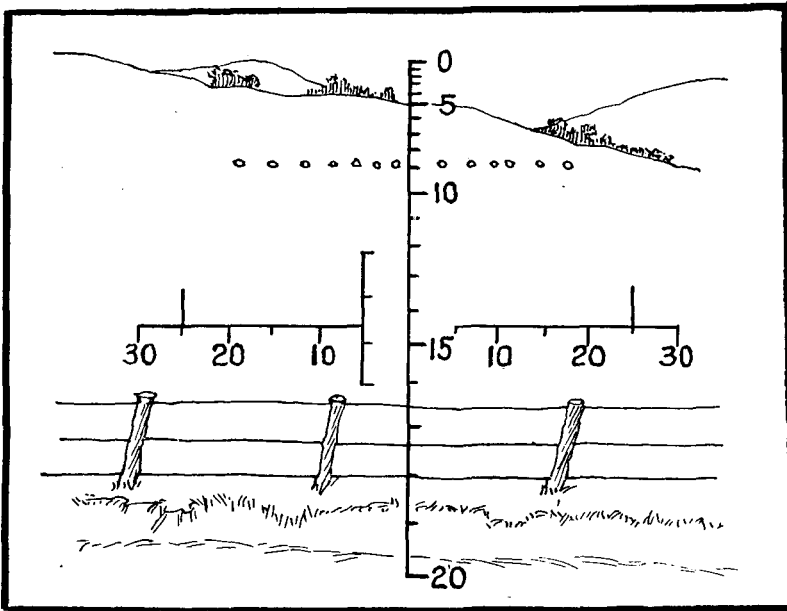

FIGURE 4.—Image, field glass, type EE.

(4) *Use of reticle.*—(a) The mil scales are seen when looking through the glass, superimposed on the observed objects. The horizontal and vertical angles may be read between them.

(b) The stadia scale is used to secure range setting on sharply defined auxiliary aiming points when the target is not clear enough for direct aiming. The target must be visible and its range known for the observer to determine these range settings. In use, the graduation marking the known range is laid on the true target. Any sharply defined object which coincides with a graduation on the scale as an auxiliary aiming point may then be selected. If, for example, the target is a line of heads 900 yards away (fig. 4), the graduation "900"

on the scale would be laid on the line of heads seen through the glass. Any one of several aiming points will then be opposite the graduations on the scale. The sky line might cross the scale at 500 and if aim is taken at the sky line with 500 yards set on the rear sight of the service rifle or machine gun the shots will fall on the line of heads at 900 yards, as intended. The bottom wire of a fence might cross the scale at 1,800 and if aim is taken on the wire with 1,800 yards elevation set on the rear sight the shots will fall in the line of heads, as intended.

c. Care and preservation.—(1) The binocular is rugged in construction but should not be subjected to rough handling.

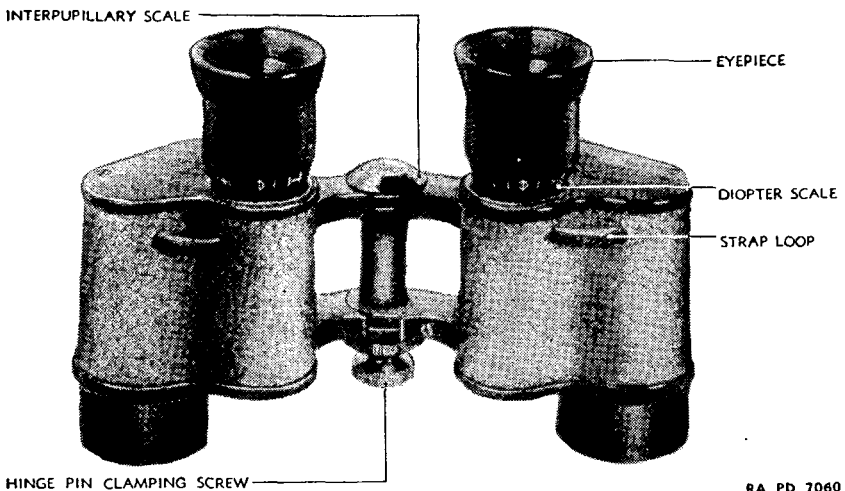

FIGURE 5.—Field glass, type EE.

RA PD 7060

(2) The instrument is not to be disassembled by the using arm. Repairs involving disassembly or painting are to be referred to ordnance maintenance personnel.

(3) The instrument should be carefully wiped dry immediately after use in wet weather and returned to the carrying case provided. Optical surfaces are to be carefully wiped with clean paper, lens tissue, a supply of which is contained in the carrying case.

(4) Binoculars should not be lubricated by the using arm.

3. Glass, field, type EE (fig. 5).—*a. General.*—These field glasses are made by either of two manufacturers, Bausch and Lomb Optical Company or the United States naval gun factory, and are so indicated on each glass. They are used for observation and approximate measurement of small angles. The Bausch and Lomb field glass is the preferred type of limited standard glass for issue to the using

arms, but the naval gun factory instrument is also limited standard. Both have the same optical characteristics, but the Bausch and Lomb field glass is smaller and is considered superior.

b. Description.—(1) The type EE field glass is a binocular field glass having 6-power magnification and an objective pupil diameter of 30 mm. It consists of two compact prismatic telescopes, pivoted about a common hinge which provides adjustment for interpupillary distances varying between 56 and 74 mm. The left telescope contains the reticle.

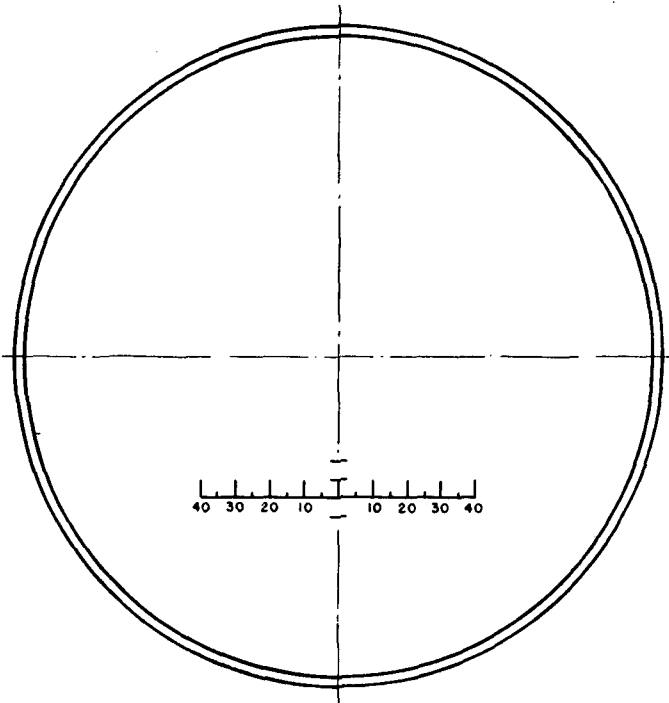

RA FSD 1243

FIGURE 6.—Field glass, type EE—new style reticle pattern.

(2) Two types of reticles may be found in this field glass, type EE:

(a) In glasses of late manufacture the reticle (fig. 6) has a horizontal mil scale in the lower portion of the field. The scale is graduated at 5-mil intervals to 40 mils right and left of center. Above and below the center of the scale are short horizontal lines which indicate 5-mil vertical intervals.

(b) In field glasses of early manufacture the reticle (fig. 7) has a horizontal mil scale graduated at 5-mil intervals to 30 mils right and left of center. The vertical stadia scale, graduated in hundreds of

yards, is used by infantry organizations in indirect firing at long range and at invisible field targets.

(3) An adjustable stop on the hinge provides for rapid setting at a predetermined point on the interpupillary scale. The stop may be disengaged to allow full hinge motion without disturbance of the stop adjustment.

(4) The neck strap secured to the strap loops of the instrument protects the instrument from accidental falls, and the russet leather carrying case with carrying loop and shoulder strap protects it when not in use.

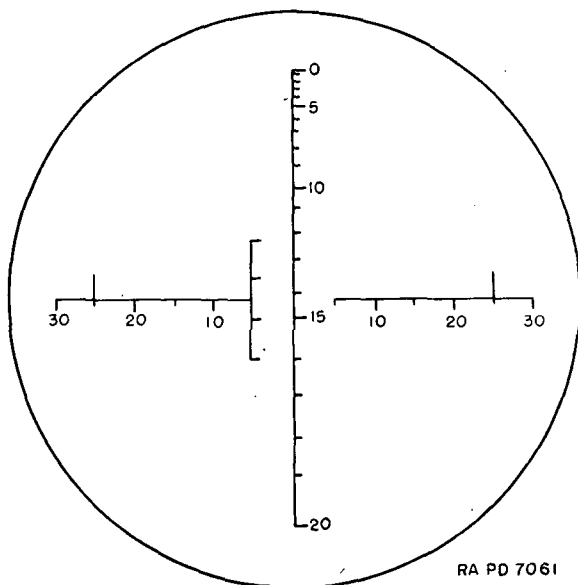

FIGURE 7.—Field glass, type EE—old style reticle pattern.

c. Operation.—Operation of this field glass is the same as that of binocular M3 with the added use of the stop on the interpupillary scale to speed the interpupillary setting (see par. 2*b*(1)).

d. Care and preservation.—Precautions taken with binocular M3 apply also to the field glass, type EE.

4. Glass, field, Huet type, 8-power.—The Huet field glass (fig. 8) is a limited standard field glass. The reticle pattern (fig. 9) consists of a vertical line and a horizontal scale, graduated at 5-mil intervals, extending 40 mils on each side of center. Operation of the Huet type field glass is the same as that of binocular M3, with the added use of an interpupillary hinge clamping knob and a reticle adjusting ring (see fig. 8). Precautions taken with binocular M3 apply also to this field glass.

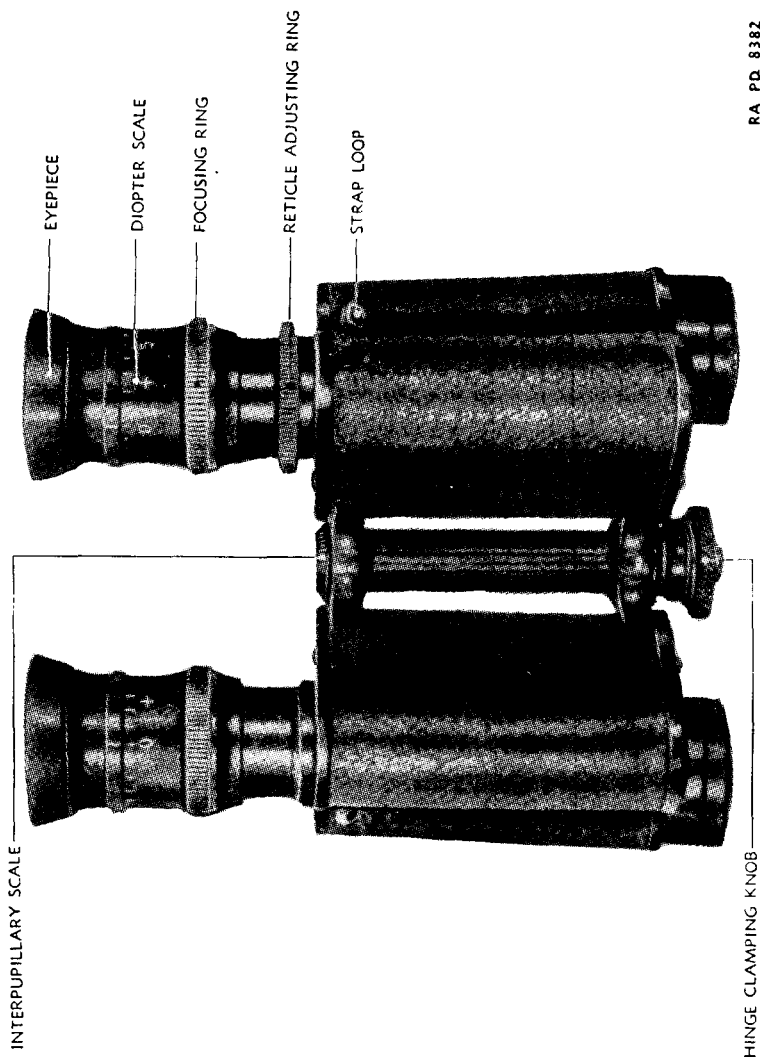

FIGURE 8.—Huet type field glass, 8-power.

RA PD 8382

5. **Glass, field, type E.**—This field glass is a limited standard field glass and has the same general characteristics as the type EE field glass, except that it is heavier and larger.

SECTION III

EYEGLASSES

Eyeglasses, amber, M2-----	Paragraph 6
Eyeglasses, red, M1-----	7

6. **Eyeglasses, amber, M2.**—*a. Description.*—(1) These eyeglasses (fig. 10) are used to reduce glare in antiaircraft observation.

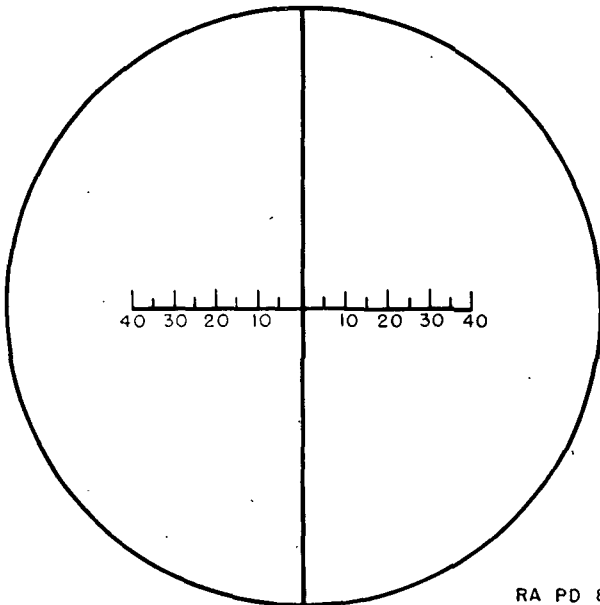

RA PD 8383

FIGURE 9.—Huet type field glass, 8-power—reticle pattern.

(2) The glasses are commercial type goggles with amber-colored ground lenses and perforated metal eyeshields which protect the eyes against grit and dirt.

(3) The metal sidepieces are covered with transparent plastic to avoid contact of the metal with the skin. The bridge of the goggles has plastic nose pads.

(4) A metal carrying case is supplied to protect the glasses when not in use.

b. Care and preservation.—The eyeglasses should be given the same care as ordinary spectacles and should be kept in the carrying case when not in use.

7. **Eyeglasses, red, M1.**—*a. Description.*—These eyeglasses are used for observing tracer fire and are the same as the amber eyeglasses M2, except for the red-colored ground lenses (fig. 10).

b. Care and preservation.—They should be given the same care as ordinary spectacles and should be kept in the carrying case when not in use.

SECTION IV

OBSERVATION TELESCOPES

Telescope, observation, M4.....	Paragraph 8
Telescope, observation, French, 3-power, M1917.....	9

8. **Telescope, observation, M4.**—*a. General.*—This telescope (figs. 11 and 12) is used for observation purposes by cavalry and in-

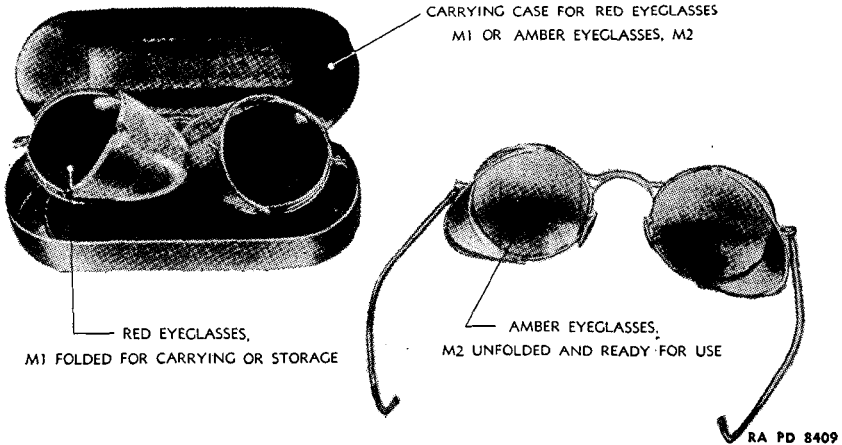

FIGURE 10.—Amber eyeglasses, M2, red eyeglasses M1, and carrying case.

fantry organizations. The complete unit consists of the telescope, tripod, and carrying cases for the telescope and tripod.

b. Description.—(1) The telescope (figs. 11 and 12) has 19.5-power magnification. The eyepiece has a knurled focusing nut. The sliding sunshade is secured to the objective end, and the objective itself is protected in travel by the objective cap which screws into the sunshade.

(2) The tripod (fig. 11) includes a cradle and web strap, ball and socket joint, spindle-shaped support, tripod head, and three legs. The cradle and web strap support and secure the telescope. The adjustable ball and socket permits pivoting, elevating, and depressing. The support may be raised or lowered. The hinged tripod legs support the telescope about one foot above the ground.

(3) The cylindrical leather carrying case (fig. 13) protects the telescope when it is not in use. A canvas carrying case, reinforced with leather, contains one pocket for the telescope and another for the tripod.

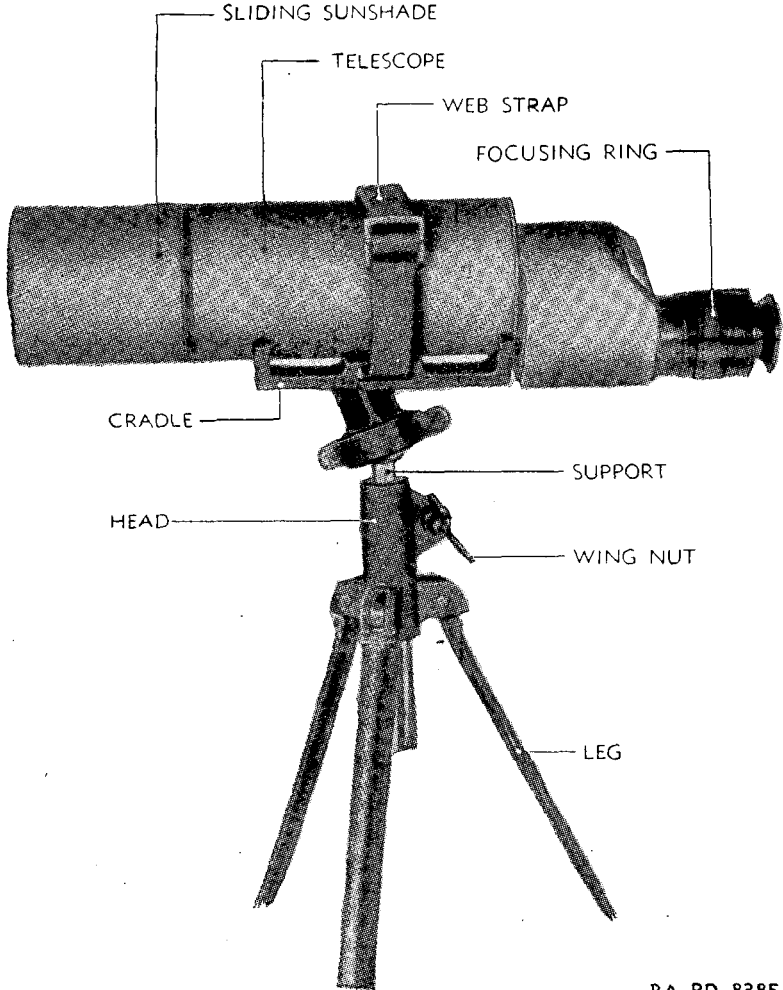

FIGURE 11. -Observation telescope M4.

RA PD 8385

c. Operation.—The telescope is set up as shown in figure 11 with the objective cap and eyepiece cap removed. It is then pointed at the target and the eyepiece adjusted to bring the target into sharp focus.

d. Care and preservation.—(1) The telescope is sturdy but should not be carelessly handled.

(2) After exposure to rain or dampness wipe the telescope carefully before returning it to the carrying case.

(3) Keep the telescope in its case when not in use.

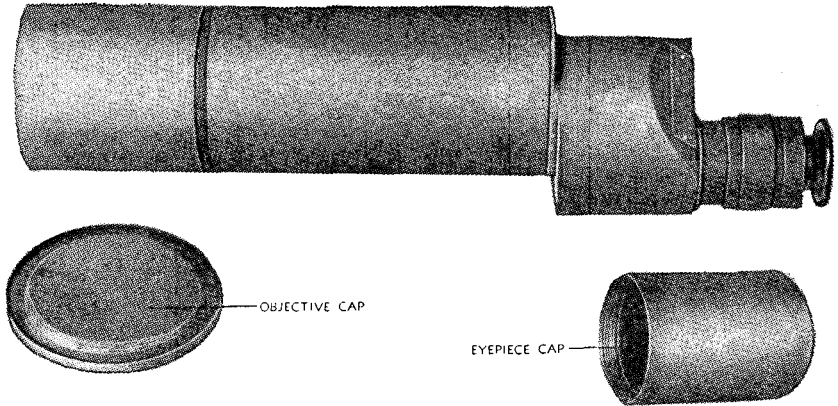

FIGURE 12.—Observation telescope M4—telescope with caps.

RA PD 8386

9. Telescope, observation, French, 3-power, M1917.—*a. General.*—This instrument (fig. 14), complete, consists of the telescope, telescope mount, azimuth mount, type X tripod, and carrying cases.

b. Description.—(1) The telescope is prismatic and has a turret at the eyepiece end which mounts three eyepieces. The eyepieces afford powers of 15, 23, and 30 and can be swung readily into position.

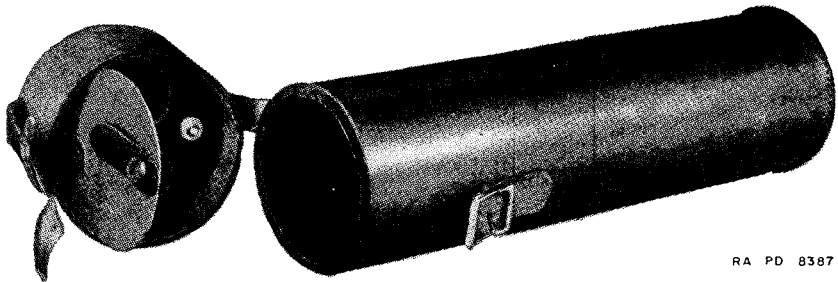

FIGURE 13.—Observation telescope M4—telescope carrying case.

RA PD 8387

Each eyepiece can be focused and includes a diopter scale for rapid setting when the correction for the observer's eye is known; zero setting is normal. The 15-power is for use on cloudy or dark days, at twilight or dawn. The 23-power is used on a normal, clear day, while the 30-power is for long range observation on a clear day.

(2) The reticle (fig. 14) contains cross lines which indicate the optical axis of the telescope, and a set of vertical and horizontal scales graduated at 5-mil intervals. A special graduation at plus 3 mils on the vertical scale indicates the normal height of burst for spotting artillery fire.

(3) The telescope mount supports the telescope in a hinged yoke and cap secured by a thumbscrew. The mount includes the angle-of-site level, the angle-of-site scale which is graduated from minus 400 to plus 400 mils, the micrometer which is graduated from 0 to 100 mils by 1-mil intervals, and the angle-of-site knob. The elevation

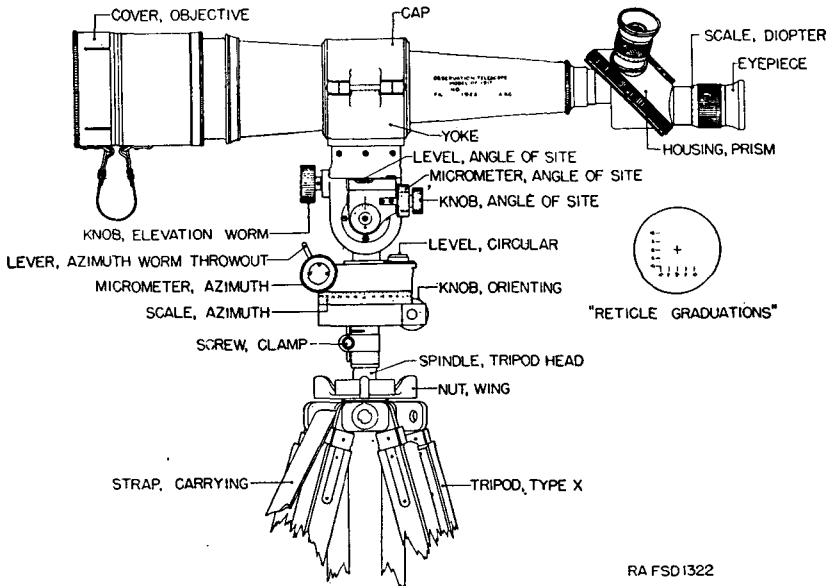

FIGURE 14.—Observation telescope, 3-power, French, M1917.

worm knob, which elevates or depresses the telescope, is also included. The telescope mount is secured to the spindle of the azimuth mount by a clamping screw, not shown in the figure.

(4) The azimuth mount has a spindle for supporting the telescope mount and contains an azimuth scale, micrometer, knob, and throw-out lever. The orienting knob is used for initial orientation of the instrument. The mount is secured to the tripod head spindle by a screw clamp.

(5) The type X tripod has a spindle for engaging the azimuth mount and has extensible wooden legs fitted with clamps for locking the legs at a convenient length. A carrying strap is provided.

legs to the desired height and embed them firmly in the ground. Place the telescope mount on the vertical spindle of the azimuth mount and clamp. Place the telescope in the telescope mount and clamp, then level by means of the ball and socket joint and circular level and clamp in position (fig. 14).

(2) To orient the telescope, set the azimuth scale and micrometer for some known reference point, loosen the clamp screw, and rotate the telescope until the cross lines are approximately on the reference point. Tighten the clamp screw and orient exactly with the orienting knob. Set the angle-of-site micrometer and scale to normal (zero).

(3) To observe an object, disengage the azimuth throw-out lever, rotate the telescope to bear approximately on the object, engage the throw-out lever, and use the azimuth micrometer knob and elevation knob to bring the telescope to bear exactly on the object. The azimuth is then indicated on the azimuth scale and micrometer. To determine the angle of site, turn the angle-of-site knob until the bubble is midway between the graduation on the level vial and note the readings on the scale and micrometer.

d. Care and preservation.—(1) When moving the instrument rapidly in azimuth, rotate the azimuth throw-out lever sufficiently to clear the worm and worm wheel and thus avoid injuring the teeth.

(2) When placing the telescope in the carrying case, set the 15-power eyepiece in the operating position to fit the case. The azimuth mount

was an ordinary timepiece with an additional auxiliary sweep hand for indicating time intervals of seconds and fractions of seconds. A time interval recorder, as formerly distinguished from a stop watch, lacked the hour, minute, and second hands of an ordinary timepiece. The terms "stop watch" and "time interval recorder" are at present applied without distinction to instruments which resemble the former time interval recorder. Such instruments do not function as timepieces but as indicators only of time intervals.

11. Recorder, time interval (fig. 15).—The time interval recorder is a limited standard split-second timer with minute register. Two classes are issued: class A, higher priced, more accurate; class B, lower priced, usually of the "plain timer" type. The main dial is graduated to read in seconds and fifths of seconds and every 5-second mark is numbered. A small subdial records minutes from 0 to 30. The recorder is stem-wound and the hands are controlled through a successive cycle of start, stop, and fly-back by successive depressions of the crown. A rubber shock absorber and a leather thong are supplied with each recorder.

12. Watch, stop, type B, class 15 (fig. 16).—This watch is a continuous running single-action stop watch having a 15-jewel movement. The second dial is graduated from 0 to 60 seconds in $\frac{1}{5}$ -second intervals. The minute dial, located just below the 60 of the second dial, is graduated from 0 to 30 minutes in 1-minute intervals. One hand registers on each dial and is controlled through the cycle of start, stop, and fly-back by successive depressions of the crown or of a push piece extending through the crown. A rubber shock absorber and a leather thong are supplied with each stop watch.

SECTION VI

WATCHES

	Paragraph
Watch, pocket, 7-jewel.....	13
Watch, pocket, 15 or more jewels.....	14
Watch, pocket, railroad grade.....	15
Watch, wrist, 7-jewel.....	16
Watch, wrist, 15 or more jewels.....	17

13. Watch, pocket, 7-jewel.—This watch (fig. 17) is an ordinary open-face timepiece authorized for war issue only to cavalry and infantry organizations. Elgin type, 7-jewel, pocket watches and Waltham type, 9-jewel, pocket watches are marked serially from OA1 to OA4407 on the back cover. The watch has hour, minute, and second hands. Hour and minute hands and the hour numerals are luminous-coated. Minute and second graduations are black. The small nu-

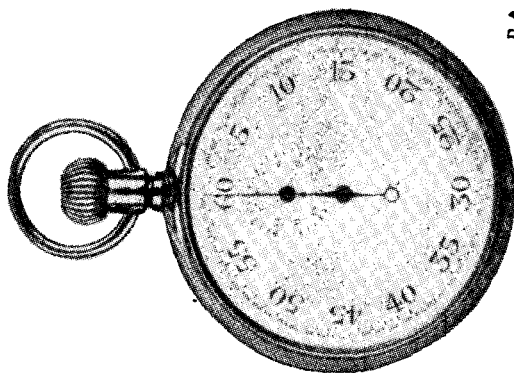

RA PD 8410

② Class B.

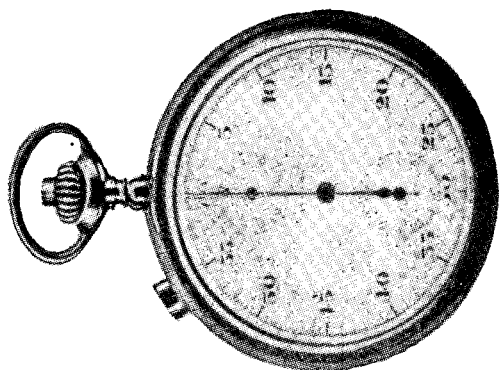

① Class A.

FIGURE 15.—Time interval recorders.

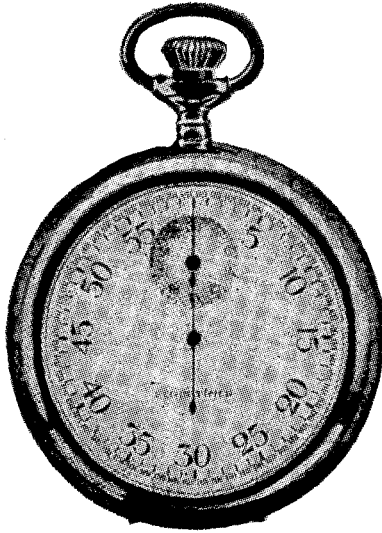

RA PD 8388

FIGURE 16.—Stop watch, type B, class 15.

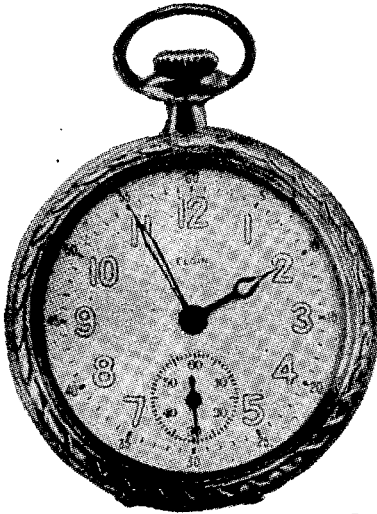

RA PD 8389

FIGURE 17.—7-jewel pocket watch.

merals, indicating the 5-minute periods, are red. The watch is stem-wound and stem-set. A rubber shock absorber and a leather thong are supplied with each watch.

14. **Watch, pocket, 15 or more jewels.**—*a.* This watch (fig. 18) is an ordinary open-face timepiece authorized for war issue only, except that meteorological control and observation stations receive this watch in time of peace in lieu of the 15 or more jewel wrist watch. Except for minor differences in the dials, as listed below, the 15 or more jewel watch is similar in external appearance to the 7-jewel watch. Elgin type, 15-jewel, pocket watches and Waltham type, 17-

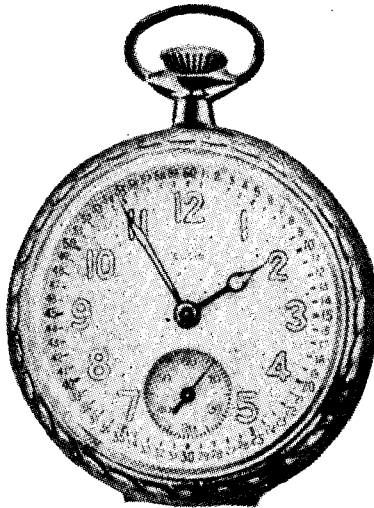

RA PD 8390

FIGURE 18.—15-jewel pocket watch.

jewel, pocket watches are marked serially from OB1 to OB6983 on the back cover.

b. The watch has hour, minute, and second hands. Hour and minute hands and hour numerals are luminous-coated. Minute and second graduations are black. The small numerals, indicating minute periods, are red. Presence of the minute period numerals identifies the watch. The watch is stem-wound and stem-set. A rubber shock absorber and a leather thong are supplied with each watch.

15. **Watch, pocket, railroad grade.**—*a.* This watch (fig. 19) is an open-face timepiece authorized for issue to the Corps of Engineers for railway use. Railroad grade pocket watches are marked serially OE— on the back of the cover.

THE ARMY LIBRARY

WASHINGTON, D.C.

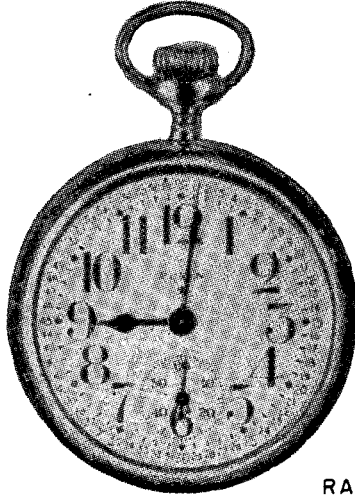

RA PD 8391

FIGURE 19.—Railroad grade pocket watch.

b. The watch has a 21-jewel movement. The dial is of white porcelain and the numerals are arabic, black, and vertical with the stem. Hour, minute, and second hands are blued steel. The outside surface of the case has a bright nickel finish. The crystal is glass.

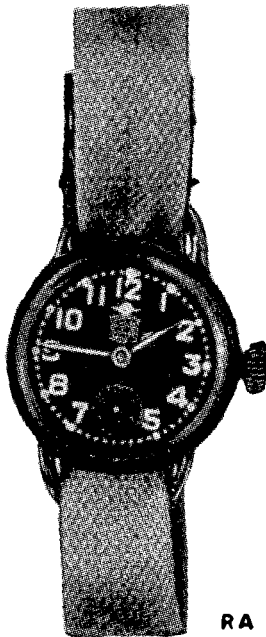

RA PD 8392

FIGURE 20.—7-jewel wrist watch.

16. **Watch, wrist, 7-jewel.**—*a.* This wrist watch (fig. 20) is authorized for issue to all services. It is a small open-face timepiece fitted with a wristlet for fastening to the wrist. The 7-jewel Elgin type wrist watch is marked serially OC1-OC31834 on the back of the cover. The watch has hour, minute, and second hands and a second dial. It is stem-wound and stem-set and is water and shock resistant to some extent. Hour and minute hands and hour numerals are luminous-coated for night use.



RA PD 8393

FIGURE 21.—15 or more jewel wrist watch.

b. The watch will run about 30 hours on a winding. The crystal is unbreakable. The wristlets may be of russet leather or of olive drab webbing.

17. **Watch, wrist, 15 or more jewels.**—*a.* This wrist watch (fig. 21) is authorized for war issue only to all services except that meteorological control and observation stations receive this watch in time of peace also. The 17-jewel Waltham type wrist watch is numbered serially OD1 to OD7769. The 15-jewel Elgin type wrist watch is numbered serially from OD7770 to OD10960. The serial number is marked on the back of the case.

b. The watch is a small open-face timepiece fitted with a wristlet for fastening to the wrist. It is stem-wound and stem-set and is dust and moisture proof. The dial is round and black. Hour numerals and the hour and minute hands are luminous-coated; second graduations, numerals, hands, and minute graduations are white.

c. The case has a durable finish and the wristlets may be of russet leather or olive drab webbing.

SECTION VII

CARE AND PRESERVATION

Paragraph

Instructions----- 18

18. **Instructions.**—*a. General.*—(1) Instructions given here supplement instructions pertaining to individual instruments included in preceding paragraphs.

(2) Fire control and sighting instruments are, in general, rugged and suited for the purposes for which they have been designed, but they will not stand rough handling or abuse. Inaccuracy or malfunctioning will result from such mistreatment.

(3) Disassembly and assembly by the using arm are permitted only to the extent authorized in the paragraphs dealing with the individual instruments. Unnecessary turning of screws or other parts not incident to the use of the instrument is expressly forbidden.

(4) Any instruments which fail to function properly are to be turned in for repair by ordnance personnel. Adjustments, other than those expressly authorized in the paragraphs dealing with the individual instruments, are not to be performed by the using arm.

(5) Be careful not to wind watches too tightly. Carry pocket watches in the pocket with the crystal side against the body as protection against damage to the crystal.

(6) No painting of fire-control equipment by the using arm is permitted.

(7) Keep the instruments as dry as possible. Never put an instrument in its carrying case wet.

(8) When not in use, keep the instruments in the carrying cases provided.

(9) When setting up tripods on sloping terrain, place two legs on the downhill side to provide maximum stability.

b. Leather articles.—Care and preservation of leather articles are covered in TM 9-850.

c. Optical parts.—(1) To obtain satisfactory vision, the exposed surfaces of the lenses and other parts must be kept clean and dry.

Corrosion and etching of the surface of the glass can be prevented or greatly retarded by keeping the glass clean and dry.

(2) Under no condition will polishing liquids, pastes, or abrasives be used for polishing lenses and windows.

(3) For wiping optical parts use only clean lens tissue paper for cleaning optical glass. Use of cleaning cloths in the field is not permitted. To remove dust, brush the glass lightly with a clean camel's-hair brush and rap the brush against a hard body to knock out small particles of dust that cling to the hairs. Repeat this operation until all dust is removed.

(4) Exercise particular care to keep optical parts free from oil and grease. Do not wipe the lenses or windows with the fingers. To remove oil or grease from optical surfaces, apply ethyl alcohol with a clean camel's-hair brush and rub gently with clean lens paper. If alcohol is not available, breathe heavily on the glass and wipe off with clean lens tissue paper; repeat this operation several times until clean.

(5) Moisture due to condensation may collect on the optical parts of the instrument when the temperature of the parts is lower than that of the surrounding air. This moisture, if not excessive, can be removed by placing the instrument in a warm place. Heat from strongly concentrated sources should never be applied directly, as it may cause unequal expansion of parts and result in breakage of optical parts or inaccuracies in observation.

d. Lubrication.—(1) Lubrication of fire-control instruments by the using arms is permitted only where specifically authorized.

(2) Use only the following lubricants in the servicing of this matériel:

(a) Grease, special, low temperature.

(b) Oil, lubricating, for aircraft instruments and machine guns.

(3) Avoid excessive lubrication. Wipe off excess lubricants to avoid accumulation of dust or grit.

APPENDIX

LIST OF REFERENCES

1. Standard Nomenclature Lists.

- a. Cleaning, preserving, and lubricating materials----- SNL K-1
- b. Fire-control matériel is as follows:
 - Binocular M3----- SNL F-210
 - Eyeglasses, amber, M2, eyeglasses, red, M1----- SNL F-74
 - Glass, field, type E, 6-power----- SNL F-34
 - Glass, field, type E, 6-power; glass, field, type EE,
6-power (U. S. Naval Gun Factory)----- SNL F-146
 - Telescope, observation, French, 3-power, M1917-- SNL F-38
 - Telescope, observation, M4----- SNL F-173
 - Watch, pocket, railroad grade----- SNL F-187
 - Watches, stop; and recorders, time interval----- SNL F-36

c. Current Standard Nomenclature Lists are as tabulated here. An up-to-date list of SNL's is maintained as the Ordnance Publications for Supply Index----- (OPSI)

2. Explanatory publications.

- a. Cleaning, preserving, and lubricating materials----- TM 9-850
- b. Field glass, type EE, 6-power----- TM 9-1611

[A. G. 062.11 (2-28-42).]

BY ORDER OF THE SECRETARY OF WAR:

G. C. MARSHALL,
Chief of Staff.

OFFICIAL:

J. A. ULIO,
Major General,
The Adjutant General.

DISTRIBUTION:

R and H 1 (6), 7 (2); R 5 (10), 10 (3); Bn and H 4 (5), 6 (3);
Bn 1 (8), 3 (5), 5 (4), 7 (3), 9 (2), 10 (3); C and H 11 (2); C
2 (1), 3 (2), 4 (10), 5 (2), 6 (4), 7 (6), 9 (3), 10 (2).
(For explanation of symbols see FM 21-6.)