

MODULAR ELECTRONICS LEARNING (MODEL) PROJECT



INSTRUMENT TRANSFORMERS

© 2018-2025 BY TONY R. KUPHALDT – UNDER THE TERMS AND CONDITIONS OF THE
CREATIVE COMMONS ATTRIBUTION 4.0 INTERNATIONAL PUBLIC LICENSE

LAST UPDATE = 17 FEBRUARY 2025

This is a copyrighted work, but licensed under the Creative Commons Attribution 4.0 International Public License. A copy of this license is found in the last Appendix of this document. Alternatively, you may visit <http://creativecommons.org/licenses/by/4.0/> or send a letter to Creative Commons: 171 Second Street, Suite 300, San Francisco, California, 94105, USA. The terms and conditions of this license allow for free copying, distribution, and/or modification of all licensed works by the general public.

Contents

1	Introduction	3
1.1	Recommendations for students	3
1.2	Challenging concepts related to instrument transformers	5
1.3	Recommendations for instructors	6
2	Tutorial	7
2.1	Potential transformers	8
2.2	Current transformers	12
2.3	Instrument transformer safety	19
2.4	Instrument transformer test switches	21
2.5	Instrument transformer terminal blocks	27
2.6	Instrument transformer burden and accuracy	29
2.6.1	Potential transformer burden and accuracy ratings	29
2.6.2	Current transformer burden and accuracy ratings	30
2.6.3	Current transformer saturation	31
2.6.4	Current transformer testing	34
2.6.5	Current transformer circuit wire resistance	36
2.6.6	Example: CT circuit wire sizing, simple	37
2.6.7	Example: CT circuit wire sizing, with DC considered	40
3	Historical References	43
3.1	Early instrument transformer safety	44
4	Derivations and Technical References	45
4.1	Electrical safety	46
4.2	Transformer parasitics	54
4.2.1	Parasitic resistance in transformers	55
4.2.2	Leakage inductance in transformers	55
4.2.3	Parasitic capacitance in transformers	56
4.2.4	Excitation and magnetization currents	57
4.2.5	Transformer testing	58

5 Questions	59
5.1 Conceptual reasoning	63
5.1.1 Reading outline and reflections	64
5.1.2 Foundational concepts	65
5.1.3 Wattmeter transformers	67
5.1.4 GFCI	69
5.1.5 PT and CT magnetic flux levels	70
5.2 Quantitative reasoning	72
5.2.1 Miscellaneous physical constants	73
5.2.2 Introduction to spreadsheets	74
5.2.3 Multi-ratio CT wiring	77
5.2.4 CT circuit voltages	78
5.2.5 Motor line currents	79
5.2.6 Transformer-isolated voltage calculations	80
5.2.7 Paralleled CTs	81
5.2.8 Series-connected CTs	82
5.2.9 Polarizing coil current	82
5.3 Diagnostic reasoning	83
5.3.1 Damaged data acquisition system	84
A Problem-Solving Strategies	87
B Instructional philosophy	89
C Tools used	95
D Creative Commons License	99
E References	107
F Version history	109
Index	110

Chapter 1

Introduction

1.1 Recommendations for students

Instrument transformers are used in the electrical power industry to step down high levels of voltage and current to modest levels which may be safely measured by voltmeters, ammeters, and other electrical instruments. They are also used to provide isolation between the power conductor(s) and the meter circuit, allowing the meter circuit to operate at or near Earth ground potential while the power conductors operate at dangerously elevated potentials.

An important feature of this module is its emphasis on electrical safety, as instrument transformer circuits can be extremely dangerous if miswired or mishandled.

Important concepts related to instrument transformers include **electromagnetism, electromagnetic induction, Faraday's Law, sources versus loads, turns ratio, grounding, common-mode voltage, isolation**, effects of **opens versus shorts, ground loops, magnetic saturation, burden, apparent power, remanence, wire resistance, Ohm's Law, Kirchhoff's Voltage Law**, and **reactance**.

Here are some good questions to ask of yourself while studying this subject:

- How might an experiment be designed and conducted to demonstrate the phenomenon of mutual inductance? What hypothesis (i.e. prediction) might you pose for that experiment, and what result(s) would either support or disprove that hypothesis?
- How might an experiment be designed and conducted to measure the turns ratio of a transformer? What hypothesis (i.e. prediction) might you pose for that experiment, and what result(s) would either support or disprove that hypothesis?
- How might an experiment be designed and conducted to measure the polarity of a transformer? What hypothesis (i.e. prediction) might you pose for that experiment, and what result(s) would either support or disprove that hypothesis?
- Why do we use instrument transformers in electrical power systems?
- What type of load should a PT always connect to, and why?

- What is the safe way to disconnect an energized PT from its load, and why?
- What type of load should a CT always connect to, and why?
- What is the safe way to disconnect an energized CT from its load, and why?
- How much voltage does a typical PT output when energized at its full rating?
- How much current does a typical CT output when energized at its full rating?
- What is the significance of a transformer's BIL rating?
- How many turns of wire are there in a typical "window" style CT?
- How do test switches ensure safe disconnection of an instrument transformer from its load?
- What might happen if we connect a load with an improper amount of burden to an instrument transformer?
- Why are CT test switches always "make-before-break"?
- What is the purpose of a multi-ratio instrument transformer?
- How do we typically specify instrument transformer accuracy ratings?
- How do CTs designed for protection purposes differ from CTs designed for metering purposes?
- What condition(s) will make a CT magnetically saturate?
- Aside from turns ratio and accuracy, what other important ratings are given to CTs?
- How may CTs be affected by transient overcurrent (i.e. fault) events?
- Why is CT circuit wire resistance an important factor in protective relay circuit design?

1.2 Challenging concepts related to instrument transformers

The following list cites concepts related to this module's topic that are easily misunderstood, along with suggestions for properly understanding them:

- **Voltage sources versus Current sources** – an voltage source maintains a constant output voltage regardless of current, while an ideal current source maintains a constant current regardless of voltage. Voltage sources are more common as sources of electrical power, and so they tend to be more familiar to students of electricity and electronics. However, some devices closely approach current-source behavior, and current transformers (CTs) in electrical power systems are a great example of these. As current sources, CTs are perfectly safe to short-circuit because that allows them to output current without having to do work on a load which means practically zero output voltage, but they are dangerous to open-circuit because they will output as much voltage as necessary to ignite an arc across the air gap of that open and sustain their output current!
- **Magnetic saturation** – this is a phenomenon where the ferromagnetic core material of a transformer becomes “saturated” with lines of magnetic flux, resulting in less additional magnetic flux for additional increases in winding current. Since Faraday's Law of Electromagnetic Induction shows us that voltage induced in a transformer winding is proportional to how rapidly the magnetic flux grows or decays over time ($V = N \frac{d\phi}{dt}$), a limit on magnetic flux growth means during those periods of time a transformer's ability to generate a secondary-winding voltage will be severely curtailed.

1.3 Recommendations for instructors

This section lists realistic student learning outcomes supported by the content of the module as well as suggested means of assessing (measuring) student learning. The outcomes state what learners should be able to do, and the assessments are specific challenges to prove students have learned.

- **Outcome** – Demonstrate effective technical reading and writing
 - Assessment – Students present their outlines of this module’s instructional chapters (e.g. Case Tutorial, Tutorial, Historical References, etc.) ideally as an entry to a larger Journal document chronicling their learning. These outlines should exhibit good-faith effort at summarizing major concepts explained in the text.
 - Assessment – Students show how quantitative results were obtained by the author in the Tutorial chapter’s examples.

- **Outcome** – Apply foundational circuit concepts to the analysis of instrument transformer circuits
 - Assessment – Calculate phasor voltages for PT and CT outputs given transformer turns ratios and three-phase line parameters; e.g. pose problems in the form of the “Transformer-isolated voltage calculations” Quantitative Reasoning question.
 - Assessment – Calculate secondary voltages and currents for CT circuits given turns ratios and impedances; e.g. pose problems in the form of the “Paralleled CTs” and “Series-connected CTs” Quantitative Reasoning questions.

- **Outcome** – Properly connect instrument transformers to protective relays
 - Assessment – Sketch a schematic diagram of a circuit employing one or more instrument transformers to send power system information to a protective relay; e.g. pose problems in the form of the “Multi-ratio CT wiring” Conceptual Reasoning question.

- **Outcome** – Diagnose a faulted instrument transformer circuit
 - Assessment – Determine likely root-cause(s) for a given failure in a data acquisition system using instrument transformers; e.g. pose problems in the form of the “Damaged data acquisition system” Diagnostic Reasoning question.

- **Outcome** – Independent research
 - Assessment – Locate potential transformer (PT) datasheets and properly interpret some of the information contained in those documents including turns ratio, voltage ratings, burden ratings, etc.
 - Assessment – Locate current transformer (CT) datasheets and properly interpret some of the information contained in those documents including turns ratio, class ratings, burden ratings, etc.

Chapter 2

Tutorial

The two measured variables relied on most heavily in the field of electrical power system metering, control and protection are *voltage* and *current*. From these primary variables we may determine impedance, reactance, resistance, as well as the reciprocals of those quantities (admittance, susceptance, and conductance).

Two common types of electrical sensors used in the power industry are *potential transformers* (PTs) and *current transformers* (CTs). These are precision-ratio electromagnetic transformers used to step high voltages and high currents down to more reasonable levels for the benefit of panel-mounted instruments to receive, display, and/or process.

2.1 Potential transformers

Electrical power systems typically operate at dangerously high voltage. It would be both impractical and unsafe to connect panel-mounted instruments directly to the conductors of a power system if the voltage of that power system exceeds several hundred Volts. For this reason, we must use a special type of step-down transformer referred to as a *potential transformer* to reduce and isolate the high line voltage of a power system to levels safe for panel-mounted instruments to input.

Shown here is a simple diagram illustrating how the high phase and line voltages of a three-phase AC power system may be sensed by low-voltage voltmeters through the use of step-down potential transformers:

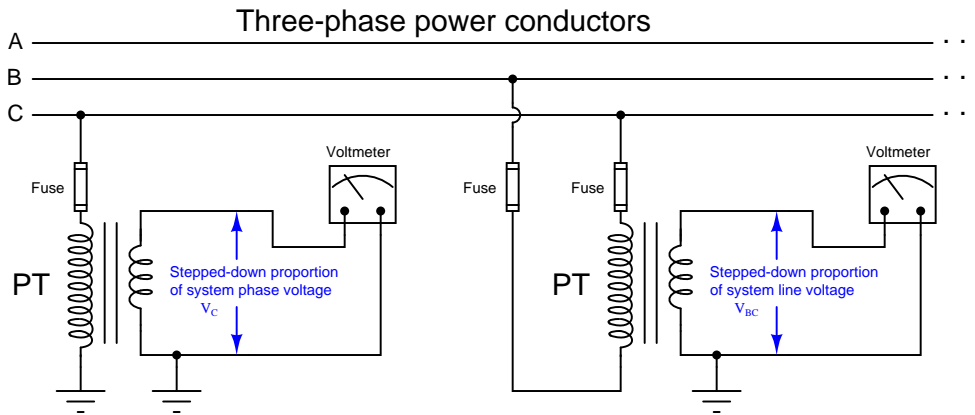

Potential transformers are commonly referred to as “PT” units in the electrical power industry. It should be noted that the term “voltage transformer” and its associated abbreviation VT is becoming popular as a replacement for “potential transformer” and PT.

When driving a voltmeter – which is essentially an open-circuit (very high resistance) – the PT behaves as a voltage source to the receiving instrument, sending a voltage signal to that instrument proportionately representing the power system’s voltage. The grounded secondary winding of the PT ensures the high common-mode voltage of the power conductors will never manifest at the voltmeter.

The following photograph shows a potential transformer sensing the phase-to-ground voltage on a three-phase power distribution system. The normal phase voltage in this system is 7.2 kV (12.5 kV three-phase line voltage), and the PT's normal secondary voltage is 120 Volts, necessitating a ratio of 60:1 (as shown on the transformer's side):



Any voltage output by this PT will be $\frac{1}{60}$ of the actual phase voltage, allowing panel-mounted instruments to read a precisely scaled proportion of the 7.2 kV (typical) phase voltage safely and effectively. A panel-mounted voltmeter, for example, would have a scale registering 7200 Volts when its actual input terminal voltage was only 120 Volts.

This next photograph shows a set of three PTs used to measure voltage on a 13.8 kV substation bus. Note how each of these PTs is equipped with *two* high-voltage insulated terminals to facilitate phase-to-phase (line voltage) measurements as well as phase-to-ground:



Another photograph of potential transformers appears here, showing three large PTs used to precisely step the phase-to-ground voltages for each phase of a 230 kV system (230 kV line voltage, 133 kV phase voltage) all the way down to 120 Volts for the panel-mounted instruments to monitor:



A loose-hanging wire joins one side of each PT's primary winding to the respective phase conductor of the 230 kV bus. The other terminal of each PT's primary winding connects to a common neutral point, forming a Wye-connected PT transformer array. The secondary terminals of these PTs connect to two-wire shielded cables conveying the 120 volt signals back to the control room where they terminate at various instruments. These shielded cables run through underground conduit for protection from weather.

Just as with the previous PT, the standard output voltage of these large PTs is 120 Volts, equating to a transformer turns ratio of about 1100:1. This standardized output voltage of 120 Volts allows PTs of any manufacture to be used with receiving instruments of any manufacture, just as the 4-20 mA standard for analog industrial instruments allows "interoperability" between different manufacturers' brands and models.

A special form of instrument transformer used on very high-voltage systems is the *capacitively-coupled voltage transformer*, or CCVT. These sensing devices employ a series-connected set of capacitors dividing the power line voltage down to a lesser quantity before it gets stepped down further by an electromagnetic transformer. A simplified diagram of a CCVT appears here, along with a photograph of three CCVTs located in a substation:

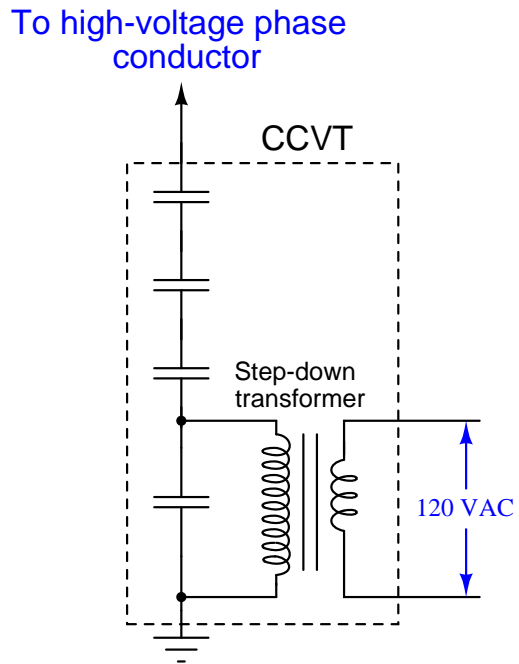

2.2 Current transformers

For the same reasons necessitating the use of potential (voltage) instrument transformers, we also see the use of *current transformers* to reduce high current values and isolate high voltage values between the electrical power system conductors and panel-mounted instruments.

Shown here is a simple diagram illustrating how the line current of a three-phase AC power system may be sensed by a low-current ammeter through the use of a current transformer:

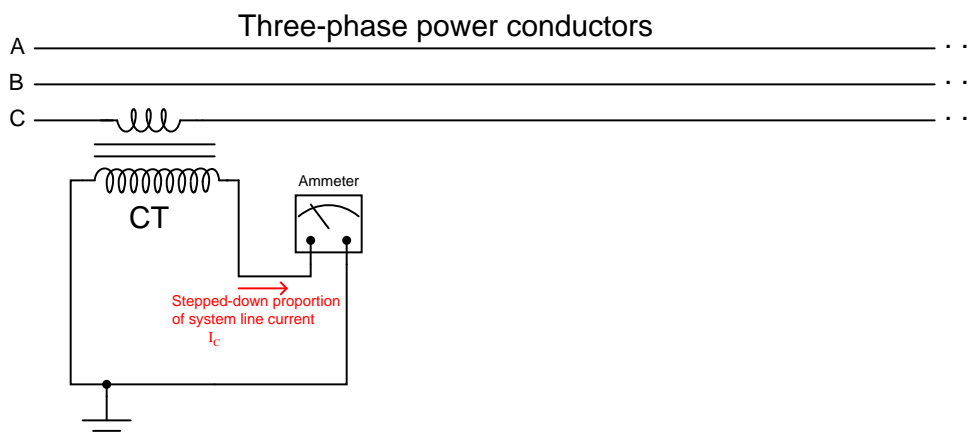

When driving an ammeter – which is essentially a short-circuit (very low resistance) – the CT behaves as a current source to the receiving instrument, sending a current signal to that instrument proportionately representing the power system’s line current. The grounded secondary winding of the CT ensures the high common-mode voltage of the power conductors will never manifest at the ammeter¹.

¹An important safety rating for current transformers is the *Basic Insulation Level*, or *BIL*. This states the dielectric strength between primary and secondary, typically expressed in kiloVolts (kV), that the CT is able to routinely withstand. If you closely examine the nameplates of CTs shown in some of the photographs contained in this tutorial, you will see voltage ratings printed on them.

In typical practice a CT consists of an iron toroid² functioning as the transformer core. This type of CT does not have a primary “winding” in the conventional sense of the word, but rather uses the line conductor itself as the primary winding. The line conductor passing once through the center of the toroid functions as a primary transformer winding with exactly 1 “turn”. The secondary winding consists of multiple turns of wire wrapped around the toroidal magnetic core:

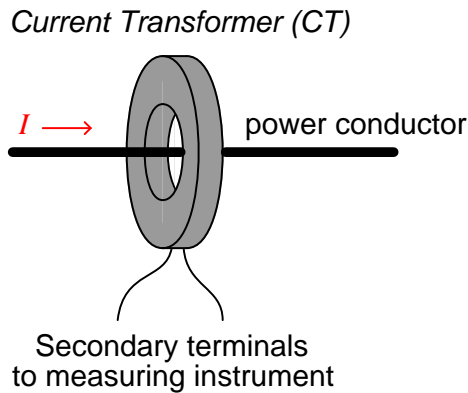

A view of a current transformer’s construction shows the wrapping of the secondary turns around the toroidal magnetic core in such a way that the secondary conductor remains parallel to the primary (power) conductor for good magnetic coupling:

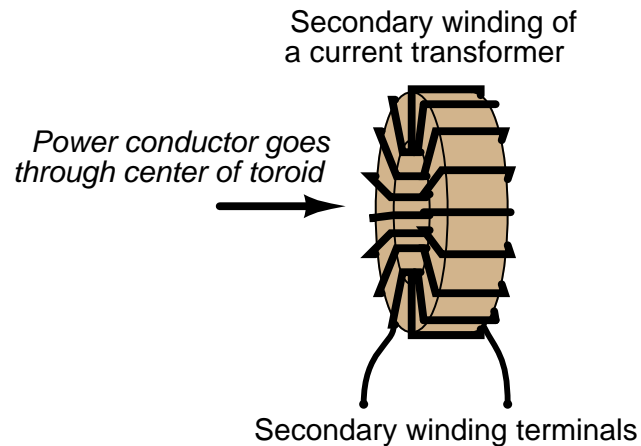

With the power conductor serving as a single-turn³ winding, the multiple turns of secondary

²A “toroid” is shaped like a donut: a circular object with a hole through the center.

³This raises an interesting possibility: if the power conductor were to be wrapped around the toroidal core of the CT so that it passes through the center *twice* instead of *once*, the current step-down ratio will be cut in half. For example, a 100:5 CT with the power conductor wrapped around so it passes through the center twice will exhibit an actual current ratio of only 50:5. If wrapped so that it passed through the CT’s center three times, the ratio would be reduced to 33.33:5. This useful “trick” may be used in applications where a lesser CT ratio cannot be found, and one must make do with whatever CT happens to be available. If you choose to do this, however, beware that the current-measuring capacity of the CT will be correspondingly reduced. Each extra turn of the power conductor

wire around the toroidal core of a CT makes it function as a step-up transformer with regard to voltage, and as a *step-down* transformer with regard to current. The turns ratio of a CT is typically specified as a ratio of full line conductor current to 5 Amperes, which is a standard output current for power CTs. Therefore, a 100:5 ratio CT consists of 20 turns of wire wrapped around the toroidal iron core (for a 20:1 turns ratio with the power conductor), and outputs 5 Amperes when the power conductor carries 100 Amperes.

The turns ratio of a current transformer suggests a danger worthy of note: if the secondary winding of an energized CT is ever open-circuited, it may develop an extremely high voltage as it attempts to force current through the air gap of that open circuit. An energized CT secondary winding acts like a current source, and like all current sources it will develop as great a potential (voltage) as it can when presented with an open circuit. Given the high voltage capability of the power system being monitored by the CT, and the CT turns ratio with more turns in the secondary than in the primary, the ability for a CT to function as a *voltage step-up* transformer poses a significant hazard.

Like any other current source, there is no harm in short-circuiting the output of a CT. Only an open circuit poses risk of damage. For this reason, CT circuits are often equipped with *shorting bars* and/or *shorting switches* to allow technicians to place a short-circuit across the CT secondary winding before disconnecting any other wires in the circuit. Later subsections will elaborate on this topic in greater detail.

adds to the magnetic flux experienced by the CT's core for any given amount of line current, making it possible to magnetically saturate the core if the line current exceeds the reduced value (e.g. 50 Amperes for the home-made 50:5 CT where the line passes twice through the center of a 100:5 CT).

Current transformers are manufactured in a wide range of sizes, to accommodate different applications. Here is a photograph of a current transformer showing the “nameplate” label with all relevant specifications. This nameplate specifies the current ratio as “100/5” which means this CT will output 5 Amperes of current when there is 100 Amperes flowing through a power conductor passed through the center of the toroid:

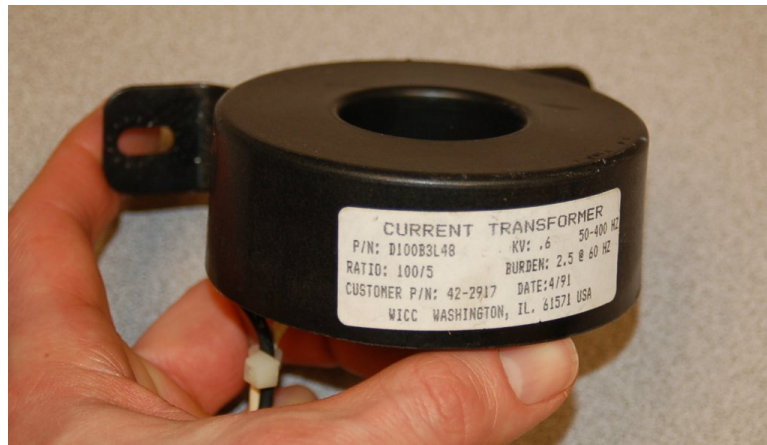

The black and white wire pair exiting this CT carries the 0 to 5 Ampere AC current signal to any monitoring instrument scaled to that range. That instrument will see $\frac{1}{20}$ (i.e. $\frac{5}{100}$) of the current flowing through the power conductor.

The following photographs contrast two different styles of current transformer, one with a “window” through which any conductor may be passed, and another with a dedicated busbar fixed through the center to which conductors attach at either end.



Here is a photograph of some much larger CTs intended for installation inside the “bushings⁴” of a large circuit breaker, stored on a wooden pallet:



The installed CTs appear as cylindrical bulges at the base of each insulator on the high-voltage circuit breaker. This particular photograph shows flexible conduit running to each bushing CT, carrying the low-current CT secondary signals to a terminal strip inside a panel on the right-hand end of the breaker:

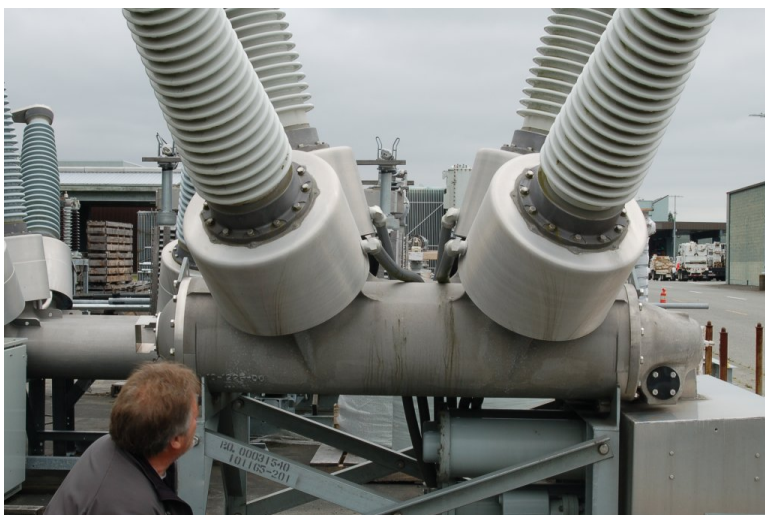

Signals from the bushing CTs on a circuit breaker may be connected to *protective relay* devices to trip the breaker in the event of any abnormal condition. If unused, a CT’s secondary terminals are simply short-circuited at the panel.

⁴High-voltage devices situate their connection terminals at the ends of long insulators, to provide a large air gap between the conductors and the grounded metal chassis of the device. The point at which the long insulator (with a conductor inside of it) penetrates the housing of the device is called the *bushing*.

Shown here is a set of three very large CTs, intended for installation at the bushings of a high-voltage power transformer. Each one has a current step-down ratio of 600-to-5:



In this next photograph we see a tiny CT designed for low current measurements, clipped over a wire carrying only a few Amperes of current. This particular current transformer is constructed in such a way that it may be clipped around an existing wire for temporary test purposes, rather than being a solid toroid where the conductor must be threaded through it for a more permanent installation:

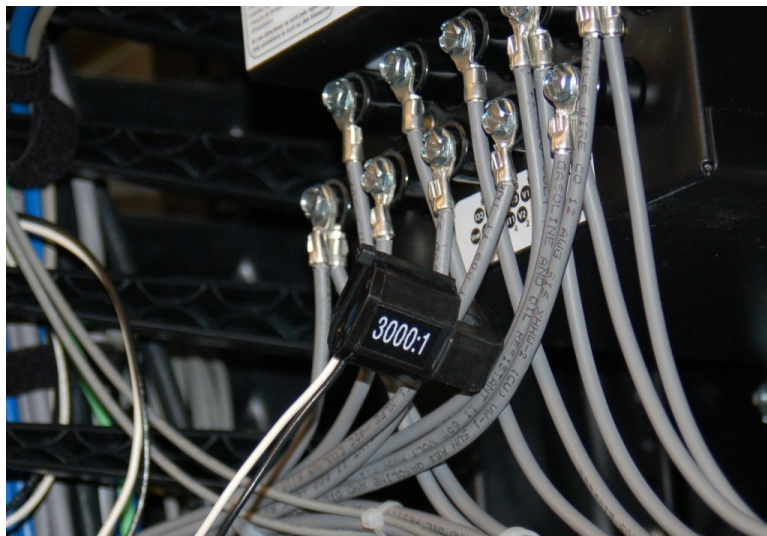

This CT's ratio of 3000:1 would step down a 5 Ampere AC signal to 1.667 milliAmperes AC.

This last photograph shows a current transformer used to measure line current in a 500 kV substation switchyard. The actual CT coil is located inside the red-colored housing at the top of the insulator, where the power conductor passes through. The tall insulator stack provides necessary separation between the conductor and the earth below to prevent high voltage from “jumping” to ground through the air:



2.3 Instrument transformer safety

Potential transformers (PTs or VTs) tend to behave as *voltage sources* to the voltage-sensing instruments they drive: the signal output by a PT is supposed to be a proportional representation of the power system's voltage. Conversely, current transformers (CTs) tend to behave as *current sources* to the current-sensing instruments they drive: the signal output by a CT is supposed to be a proportional representation of the power system's current. The following schematic diagrams show how PTs and CTs should behave when sourcing their respective instruments:

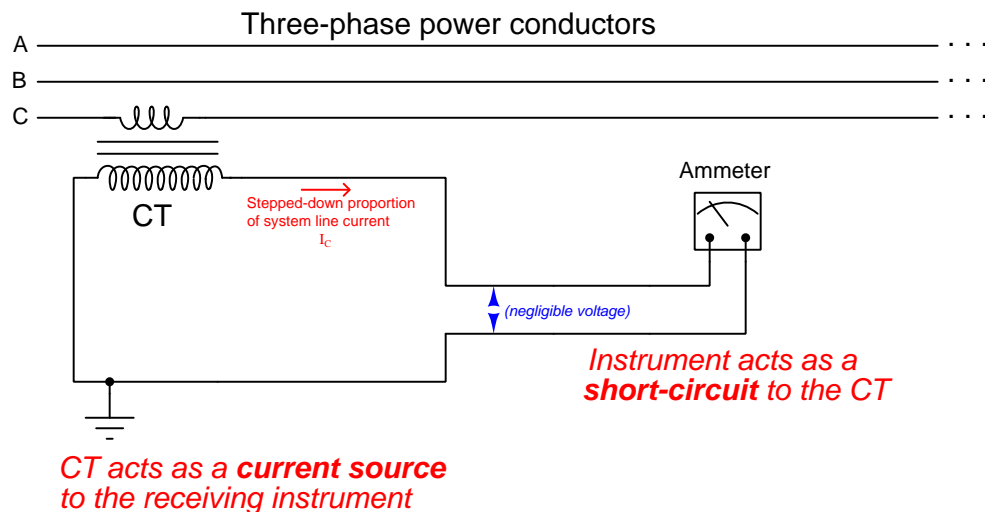
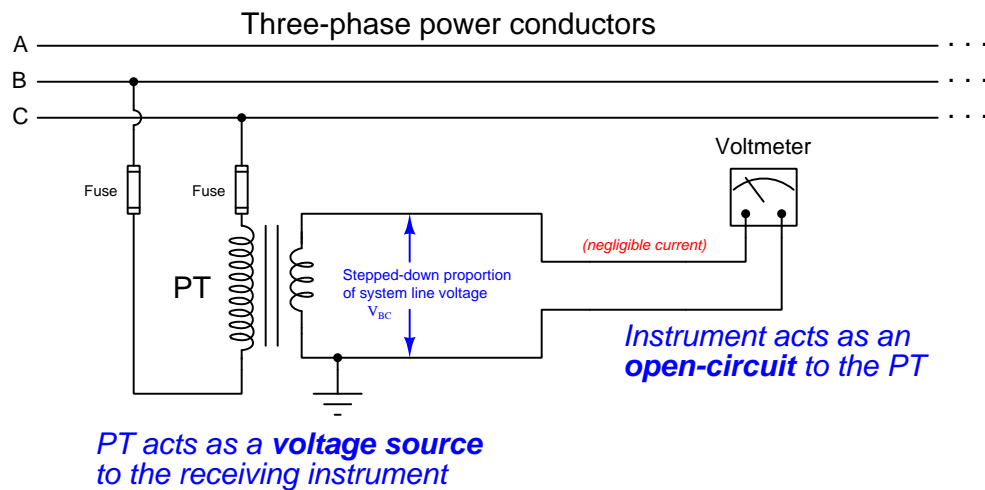

In keeping with this principle of PTs as voltage sources and CTs as current sources, *a PT's secondary winding should never be short-circuited and a CT's secondary winding should never be open-circuited!* Short-circuiting a PT's secondary winding may result in a dangerous amount of current developing in the circuit because the PT will attempt to maintain a substantial voltage across a very low resistance. Open-circuiting a CT's secondary winding may result in a dangerous amount of voltage⁵ developing between the secondary terminals because the CT will attempt to drive a substantial current through a very high resistance.

This is why you will never see fuses in the secondary circuit of a current transformer. Such a fuse, when blown open, would pose a greater hazard to life and property than a closed circuit with any amount of current the CT could muster.

While the recommendation to never short-circuit the output of a PT makes perfect sense to any student of electricity or electronics who has been drilled never to short-circuit a battery or a laboratory power supply, the recommendation to never *open-circuit* a powered CT often requires some explanation. Since CTs transform current, their output current value is naturally limited to a fixed ratio of the power conductor's line current. That is to say, short-circuiting the secondary winding of a CT will *not* result in more current output by that CT than what it would output to any normal current-sensing instrument! In fact, a CT encounters minimum "burden" when powering a short-circuit because it doesn't have to output any substantial voltage to maintain that amount of secondary current. It is only when a CT is forced to output current through a substantial impedance that it must "work hard" (i.e. output more power) by generating a substantial secondary voltage along with a secondary current.

The latent danger of a CT is underscored by an examination of its primary-to-secondary turns ratio. A single conductor passed through the aperture of a current transformer acts as a winding with one turn, while the multiple turns of wire wrapped around the toroidal core of a current transformer provides the ratio necessary to step down current from the power line to the receiving instrument. However, as every student of transformers knows, while a secondary winding possessing more turns of wire than the primary *steps current down*, that same transformer conversely will *step voltage up*. This means an open-circuited CT behaves as a voltage step-up transformer. Given the fact that the power line being measured usually has a dangerously high voltage to begin with, the prospect of an instrument transformer stepping that voltage up even higher is sobering indeed. In fact, the only way to ensure a CT will not output high voltage when powered by line current is to keep its secondary winding loaded with a low impedance.

It is also imperative that all instrument transformer secondary windings be solidly *grounded* to prevent dangerously high voltages from developing at the instrument terminals via capacitive coupling with the power conductors. Grounding should be done at only one point in each instrument transformer circuit to prevent *ground loops* from forming and potentially causing measurement errors. The preferable location of this grounding is at the first point of use, i.e. the instrument or panel-mounted terminal block where the instrument transformer's secondary wires land. If any test switches exist between the instrument transformer and the receiving instrument, the ground connection must be made in such a way that opening the test switch does not leave the transformer's secondary winding floating (ungrounded).

⁵The hazards of an open-circuited CT can be spectacular. I have spoken with power electricians who have personally witnessed huge arcs develop across the opened terminals in a CT circuit! This safety tip is not one to be lightly regarded.

2.4 Instrument transformer test switches

Connections made between instrument transformers and receiving instruments such as panel-mounted meters and relays must be occasionally broken in order to perform tests and other maintenance functions. An accessory often seen in power instrument panels is a *test switch bank*, consisting of a series of knife switches. A photograph of a test switch bank manufactured by ABB is seen here:



Some of these knife switches serve to disconnect potential transformers (PTs) from receiving instruments mounted on this relay panel, while other knife switches in the same bank serve to disconnect current transformers (CTs) from receiving instruments mounted on the same panel.

For added security, covers may be installed on the switch bank to prevent accidental operation or electrical contact. Some test switch covers are even lock-able by padlock, for an added measure of access prevention.

Test switches used to disconnect potential transformers (PTs) from voltage-sensing instruments are nothing more than simple single-pole, single-throw (SPST) knife switches, as shown in this diagram:

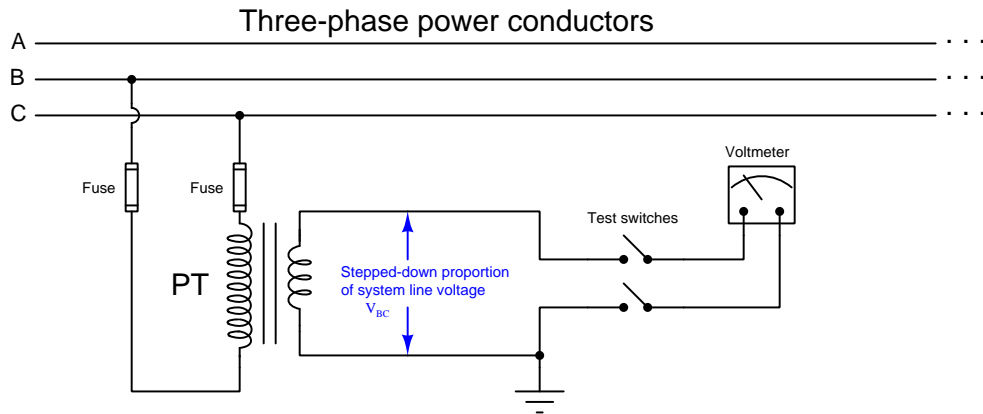

There is no danger in open-circuiting a potential transformer circuit, and so nothing special is needed to disconnect a PT from a receiving instrument.

A series of photographs showing the operation of one of these knife switches appears here, from closed (in-service) on the left to open (disconnected) on the right:



Test switches used to disconnect current transformers (CTs) from current-sensing instruments, however, must be specially designed to avoid opening the CT circuit when disconnecting, due to the high-voltage danger posed by open-circuited CT secondary windings. Thus, CT test switches are designed to place a *short-circuit* across the CT's output before opening the connection to the current-measuring device. This is done through the use of a special *make-before-break* knife switch:

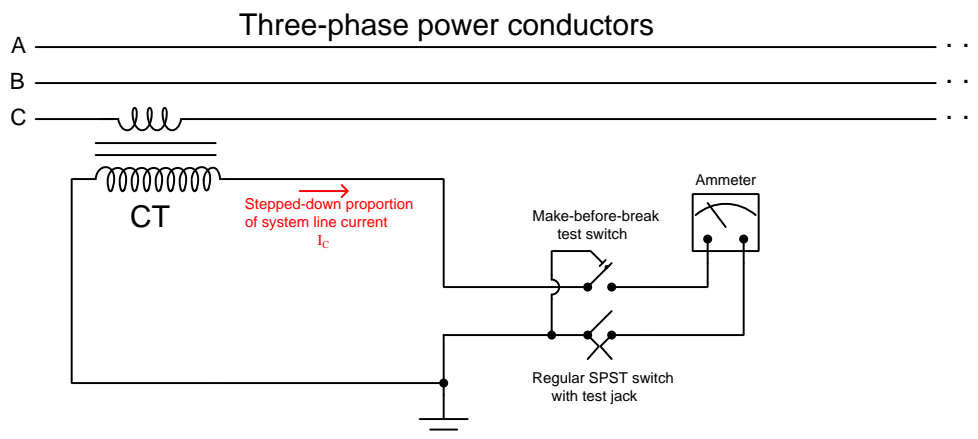

A series of photographs showing the operation of a make-before-break knife switch appears here, from closed (in-service) on the left to shorted (disconnected) on the right:

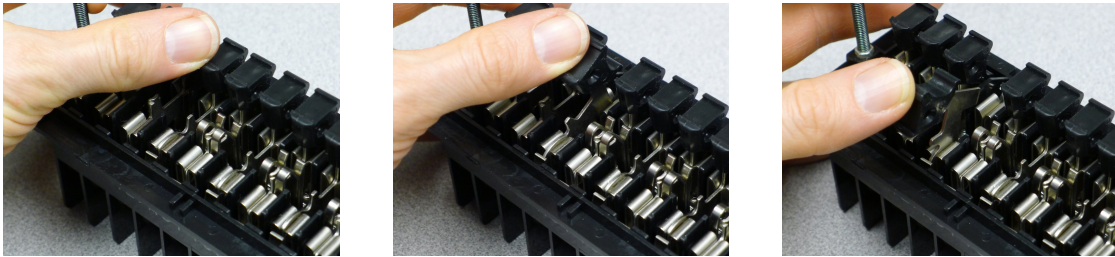

The shorting action takes place at a spring-steel leaf contacting the moving knife blade at a cam cut near the hinge. Note how the leaf is contacting the cam of the knife in the right-hand and middle photographs, but not in the left-hand photograph. This metal leaf joins with the base of the knife switch adjacent to the right (the other pole of the CT circuit), forming the short-circuit between CT terminals necessary to prevent arcing when the knife switch opens the circuit to the receiving instrument.

A step-by-step sequence of illustrations shows how this shorting spring works to prevent the CT circuit from opening when the first switch is opened:

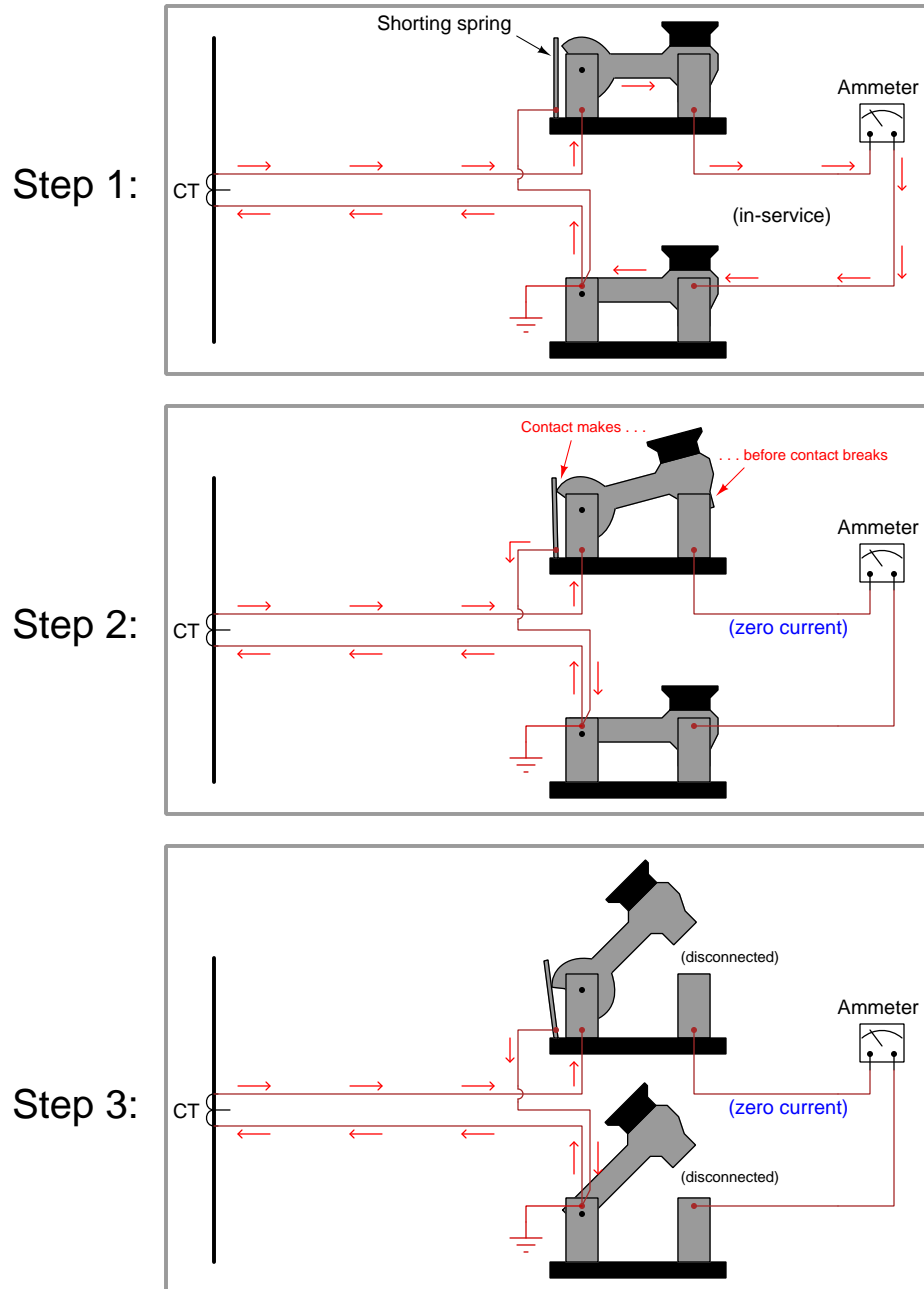

It is typical that the non-shorting switch in a CT test switch pair be equipped with a “test jack” allowing the insertion of an additional ammeter in the circuit for measurement of the CT’s signal. This test jack consists of a pair of spring-steel leafs contacting each other in the middle of the knife switch’s span. When that knife switch is in the open position, the metal leafs continue to provide continuity past the open knife switch. However, when a special ammeter adapter plug is forced between the leafs, spreading them apart, the circuit breaks and the current must flow through the two prongs of the test plug (and to the test ammeter connected to that plug).

A step-by-step sequence of illustrations shows how a test jack maintains continuity across an opened knife switch, and then allows the insertion of a test probe and ammeter, without ever breaking the CT circuit:

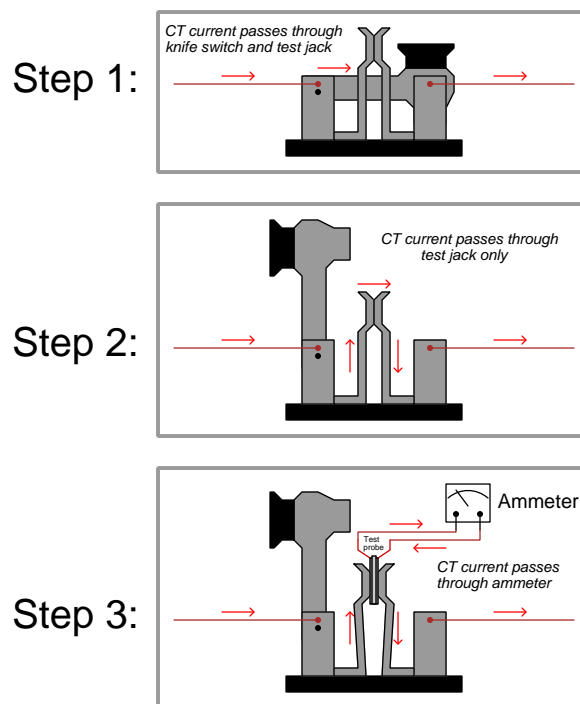

When using a CT test probe like this, one must be sure to thoroughly test the electrical continuity of the ammeter and test leads before inserting the probe into the test jacks. If there happens to be an “open” fault anywhere in the ammeter/lead circuit, a dangerous arc will develop at the point of that “open” the moment the test probe forces the metal leafs of the test jack apart! Always remember that a live CT is dangerous when open-circuited, and so your personal safety depends on always maintaining electrical continuity in the CT circuit.

The following close-up photographs show a closed CT test switch equipped with a test jack (left), and a test plug inserted into this jack (right). Note how the jack's spring leaves are visible in the middle of the switch in full contact with each other (left) and then forced apart by the test probe (right). The metallized faces of the test probe make contact with the left and right halves of the test jack to ensure continuity through the test probe (and by extension, through the ammeter connected to the test probe):

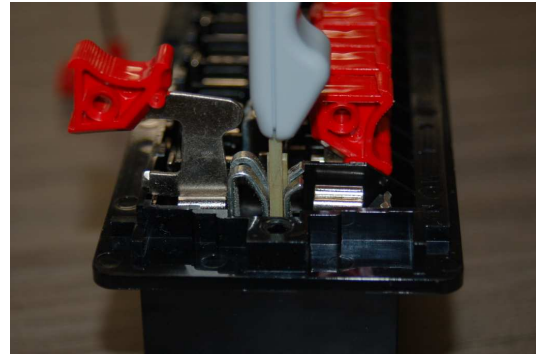
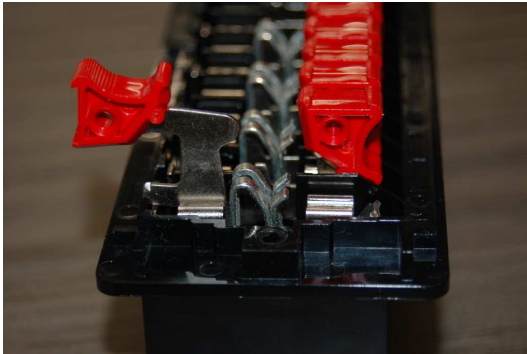

As previously mentioned, it is imperative that the ammeter and test probe as a whole assembly be electrically continuous, because inserting the probe into the jack on a live CT circuit will otherwise break that circuit and create a dangerous (high-voltage) condition. For this reason, protective relay technicians are known to replace the overcurrent protection fuse in their multimeters with a brass slug or other uninterruptible current element so that there is no chance of an open-circuit condition happening except perhaps for an open fault occurring within the ammeter itself.

2.5 Instrument transformer terminal blocks

In addition to (or sometimes in lieu of) test switches, current transformer secondary wiring often passes through special “shorting” terminal blocks. These special terminal blocks have a metal “shorting bar” running down their center, through which screws may be inserted to engage with wired terminals below. Any terminals made common to this metal bar will necessarily be equipotential to each other. One screw is always inserted into the bar tapping into the earth ground terminal on the terminal block, thus making the entire bar grounded. Additional screws inserted into this bar force CT secondary wires to ground potential. A photo of such a shorting terminal block is shown here, with five conductors from a multi-ratio (multi-tap) current transformer labeled 7X1 through 7X5 connecting to the terminal block from below:

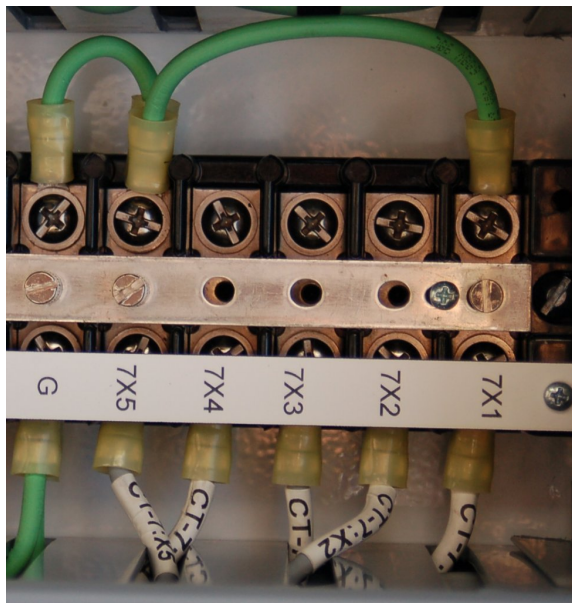

This shorting terminal block has three screws inserted into the shorting bar: one bonding the bar to the ground (“G”) terminal on the far-left side, another one connecting to the “7X5” CT wire, and the last one connecting to the “7X1” CT wire. While the first screw establishes earth ground potential along the shorting bar, the next two screws form a short circuit between the outer two conductors of the multi-ratio current transformer. Note the green “jumper” wires attached to the top side of this terminal block shorting 7X1 to 7X5 to ground, as an additional measure of safety for this particular CT which is currently unused and not connected to any measuring instrument.

The following illustrations show combinations of screw terminal positions used to selectively ground different conductors on a multi-ratio current transformer. The first of these illustrations show the condition represented in the previous photograph, with the entire CT shorted and grounded:

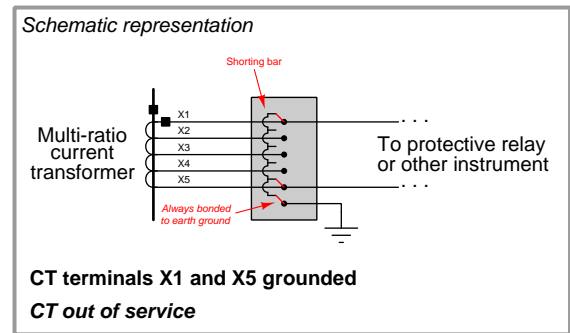
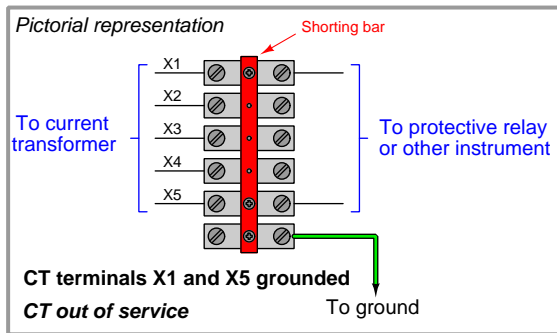

This next illustration shows how the CT would be used in its full capacity, with X1 and X5 connecting to the panel instrument and (only) X5 grounded for safety:

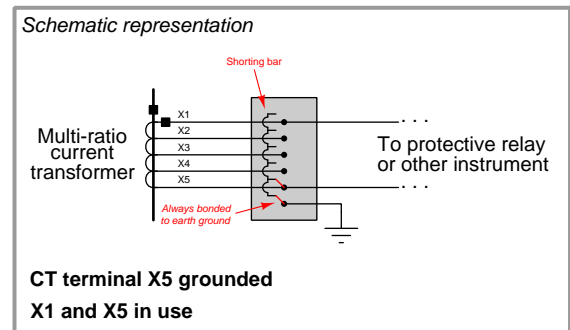
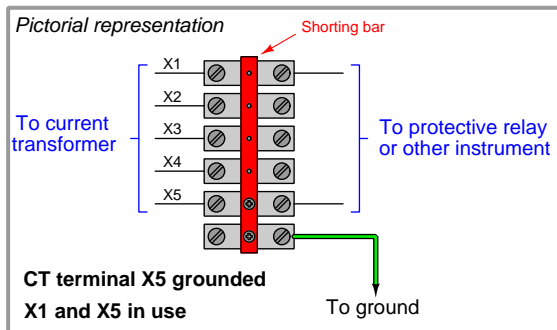

This final illustration shows how the CT would be used in reduced capacity, with X2 and X3 connecting to the panel instrument and (only) X3 grounded for safety:

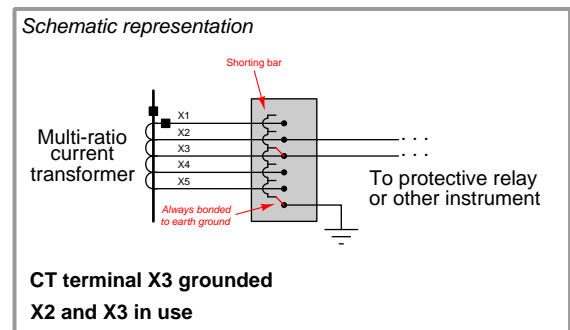
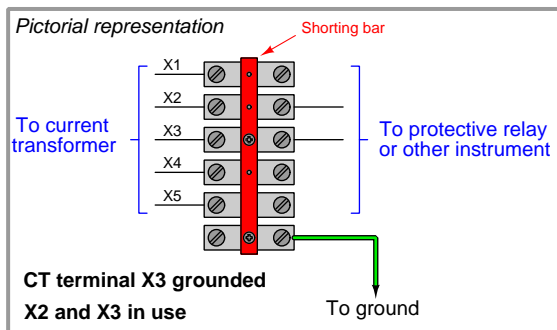

2.6 Instrument transformer burden and accuracy

In order for an instrument transformer to function as an accurate sensing device, it must not be unduly tasked with delivering power to a load. In order to minimize the power demand placed on instrument transformers, an ideal voltage-measuring instrument should draw zero current from its PT, while an ideal current-measuring instrument should drop zero voltage across its CT.

The goal of delivering zero power to any instrument is difficult to achieve in practice. Every voltmeter does indeed draw some current, however slight. Every ammeter does drop some voltage, however slight. The amount of apparent power drawn from any instrument transformer is appropriately called *burden*, and like all expressions of apparent power is measured in units of Volt-Amperes. The greater this burden, the more the instrument transformer’s signal will “sag” (decrease from loading). Therefore, minimizing burden is a matter of maximizing accuracy for power system measurement.

The burden value for any instrument transformer is a function of apparent power, impedance, and either voltage or current according to the familiar apparent power formulae $S = \frac{V^2}{Z}$ and $S = I^2 Z$:

$$\text{PT burden} = \frac{V_{\text{signal}}^2}{Z_{\text{instrument}}}$$

$$\text{CT burden} = (I_{\text{signal}}^2)(Z_{\text{instrument}})$$

Burden for any device or circuit connected to an instrument transformer may be expressed as an impedance value (Z) in Ohms, or as an apparent power value (S) in Volt-Amperes. Similarly, instrument transformers themselves are usually rated for the amount of burden they may source and still perform within a certain accuracy tolerance (e.g. $\pm 1\%$ at a burden of 2 VA).

2.6.1 Potential transformer burden and accuracy ratings

Potential transformers have maximum burden values specified in terms of apparent power (S , measured in Volt-Amperes), standard burden values being classified by letter code:

Letter code	Maximum allowable burden at stated accuracy
W	12.5 Volt-Amperes
X	25 Volt-Amperes
M	35 Volt-Amperes
Y	75 Volt-Amperes
Z	200 Volt-Amperes
ZZ	400 Volt-Amperes

Standard accuracy classes for potential transformers include 0.3, 0.6, and 1.2, corresponding to uncertainties of $\pm 0.3\%$, $\pm 0.6\%$, and $\pm 1.2\%$ of the rated turns ratio, respectively. These accuracy class and burden ratings are typically combined into one label. A potential transformer rated “0.6M” therefore has an accuracy of $\pm 0.6\%$ (this percentage being understood as its *turns ratio* accuracy) while powering a burden of 35 Volt-Amperes at its nominal (e.g. 120 Volts) output.

2.6.2 Current transformer burden and accuracy ratings

Current transformer accuracies and burdens are more complicated than potential transformer ratings. The principal reason for this is the wider range of CT application. If a current transformer is to be used for *metering* purposes (i.e. driving wattmeters, ammeters, and other instruments used for regulatory control and/or revenue billing where high accuracy is required), it is assumed the transformer will operate within its standard rated current values. For example, a 600:5 ratio current transformer used for metering should rarely if ever see a primary current value exceeding 600 Amperes, or a secondary current exceeding 5 Amperes. If current values through the CT ever do exceed these maximum standard values, the effect on regulation or billing will be negligible because these should be transient events. However, protective relays are designed to interpret and act upon transient events in power systems. If a current transformer is to be used for *relaying* rather than metering, it must reliably perform under overload conditions typically created by power system faults. In other words, relay applications of CTs demand a much larger dynamic range of measurement than meter applications. Absolute accuracy is not as important for relays, but we must ensure the CT will give a reasonably accurate representation of line current during fault conditions in order for the protective relay(s) to function properly. PTs, even those used for protective relaying purposes, never see voltage transients as wide-ranging as the current transients seen by CTs.

Meter class CT ratings typically take the form of a percentage value followed by the letter “B” followed by the maximum burden expressed in Ohms of impedance. Therefore, a CT with a metering classification of 0.3B1.8 exhibits an accuracy of $\pm 0.3\%$ of turns ratio when powering a 1.8 Ohm meter impedance at 100% output current (typically 5 Amperes).

Relay class CT ratings typically take the form of a maximum *voltage* value dropped across the burden at 20 times rated current (i.e. 100 Amperes secondary current for a CT with a 5 Ampere nominal output rating) while maintaining an accuracy within $\pm 10\%$ of the rated turns ratio. Not coincidentally, this is how CT ratios are usually selected for power system protection: such that the maximum expected symmetrical fault current through the power conductor does not exceed 20 times the primary current rating of the CT⁶. Therefore, a CT with a relay classification of C200 is able to output up to 200 Volts while powering its maximum burden at $20\times$ rated current. Assuming a rated output current of 5 Amperes, 20 times this value would be 100 Amperes delivered to the relay. If the relay’s voltage drop at this current is allowed to be as high as 200 Volts, it means the CT secondary circuit may have an impedance value of up to 2 Ohms ($200\text{ V} \div 100\text{ A} = 2\ \Omega$). Therefore, a relaying CT rating of C200 is just another way of saying it can power as much as 2 Ohms of burden.

The letter “C” in the “C200” rating example stands for *calculated*, which means the rating is based on theory. Some current transformers use the letter “T” instead, which stands for *tested*. These CTs have been actually tested at the specified voltage and current values to ensure their performance under real-world conditions.

⁶For example, in an application where the maximum fault current is expected to be 40,000 Amperes, we would choose a CT with a ratio of at least 2000:5 to drive the protective relay, because 40,000 Amperes is twenty times this CT’s primary current rating of 2000 Amperes. We could also select a CT with a larger ratio such as 3000:5. The point is to have the CT be able to faithfully transform any reasonable fault current into a proportionately lower value for the protective relay(s) to sense.

2.6.3 Current transformer saturation

It is worthwhile to explore the concept of maximum CT burden in some detail. In an ideal world, a CT acts as a current source to the meter or relay it is powering, and as such it is quite content to drive current into a short circuit (0 Ohms impedance). Problems arise if we demand the CT to supply more power than it is designed to, which means forcing the CT to drive current through an excessive amount of impedance. In the days of electromechanical meters and protective relays where the devices were entirely powered by instrument transformer signals, the amount of burden imposed by certain meters and relays could be quite substantial⁷. Modern electronic meters and relays pose much less burden to instrument transformers, approaching the ideal conditions of zero impedance for current-sensing inputs.

The voltage developed by any inductance, including transformer windings, is described by Faraday's Law of Electromagnetic Induction:

$$V = N \frac{d\Phi}{dt}$$

Where,

V = Induced voltage (Volts)

N = Number of turns of wire

$\frac{d\Phi}{dt}$ = Rate of change of magnetic flux (Webers per second)

To generate a larger voltage, therefore, a current transformer must develop a faster-changing magnetic flux in its core. If the voltage in question is sinusoidal at a constant frequency, the magnetic flux also traces a sinusoidal function over time, the voltage peaks coinciding with the steepest points on the flux waveform, and the voltage "zero" points coinciding with the peaks on the flux waveform where the rate-of-change of magnetic flux over time is zero:

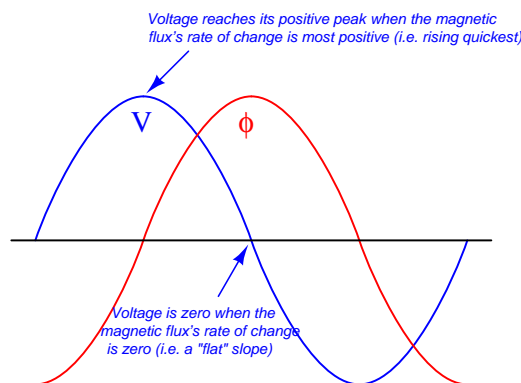

⁷An illustrative example to consider is the venerable Westinghouse model CO-11 overcurrent relay, exhibiting a burden of 1.07 Volt-Amperes at a CT secondary current of 5 Amperes with a 5-Ampere tap setting. By contrast, an SEL-551 digital overcurrent relay exhibits only 0.16 Volt-Amperes of burden at the same CT current of 5 Amperes: nearly *seven times less* burden than the electromechanical relay. The reason for this stark disparity in burden values is the design of each relay: the electromechanical relay demands power from the CT to spin an aluminum disk against the restraining forces of a spring and a drag magnet, while the electronic relay receives operating power from a separate source (station power) and only requires that the CT drive the input of an analog-to-digital converter (ADC) circuit.

Imposing a larger burden on a CT (i.e. more impedance the current must drive through) means the CT must develop a larger sinusoidal voltage for any given amount of measured line current. This equates to a flux waveform with a faster-changing rate of rise and fall, which in turn means a higher-peak flux waveform (assuming a sinusoidal shape). The problem with this at some point is that the required magnetic flux reaches such high peak values that the ferrous⁸ core of the CT begins to saturate with magnetism, at which point the CT ceases to behave in a linear fashion and will no longer faithfully reproduce the shape and magnitude of the power line current waveform. In simple terms, if we place too much burden on a CT it will begin to output a distorted signal no longer faithfully representing line current.

The fact that a CT's maximum AC voltage output depends on the magnetic saturation limit of its ferrous core becomes particularly relevant to *multi-ratio* CTs where the secondary winding is provided with more than two "taps". Multi-ratio current transformers are commonly found as the permanently mounted CTs in the bushings of power transformers, giving the end-user freedom in configuring their metering and protection circuits. Consider this distribution transformer bushing 600:5 CT with a C800 accuracy class rating:

Multi-ratio CT

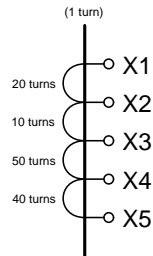

Current ratio	Taps
50:5	X2-X3
100:5	X1-X2
150:5	X1-X3
200:5	X4-X5
250:5	X3-X4
300:5	X2-X4
400:5	X1-X4
450:5	X3-X5
500:5	X2-X5
600:5	X1-X5

This CT's "C800" classification is based on its ability to source a maximum of 800 Volts to a burden *when all of its secondary turns are in use*. That is to say, its rating is "C800" only when connected to taps X1 and X5 for the full 600:5 ratio. If someone happens to connect to taps X1-X3 instead, using only 30 turns of wire in the CT's secondary instead of all 120 turns, this CT will be limited to sourcing 200 Volts to a burden before saturating: the same magnitude of magnetic flux that could generate 800 Volts across 120 turns of wire can only induce one-quarter as much voltage across one-quarter the number of turns, in accordance with Faraday's Law of Electromagnetic Induction ($V = N \frac{d\Phi}{dt}$). Thus, the CT must be treated as a "C200" unit when wired for a 150:5 ratio.

⁸Iron and iron alloys ("ferrous") reach a point of maximum magnetization where all the magnetic "domains" in a sample are oriented in the same direction, leaving no more left to orient. Once a sample of ferrous material has thus "saturated", it is of no further benefit to the establishment of a magnetic field. Increases in magnetic force will still produce additional lines of magnetic flux, but not at the rate experienced when the material was not saturated. In other words, a magnetically saturated inductor or transformer core essentially behaves like an air-core inductor or transformer for all additional current values beyond full saturation.

The presence of any direct current in AC power line conductors poses a problem for current transformers which may only be understood in terms of magnetic flux in the CT core. Any direct current (DC) in a power line passing through a CT biases the CT's magnetic field by some amount, making CT saturate more easily in one half-cycle of the AC than the other. Direct currents never sustain indefinitely in AC power systems, but are often present as transient pulses during certain fault conditions. Even so, transient DC currents will leave CT cores with some residual magnetic bias predisposing them to saturation in future fault conditions. The ability of a CT core to retain some magnetic flux over time is called *remanence*.

Remanence in a transformer core is an undesirable property. It may be mitigated by designing the core with a air gap (rather than making the core as an unbroken path of ferrous metal), but this compromises other desirable properties such as saturation limits (i.e. maximum output voltage). Some industry experts advise CTs be demagnetized by maintenance personnel as part of the repair work following a high-current fault, in order to ensure optimum performance when the system is returned to service. Demagnetization consists of passing a large AC current through the CT and then slowly reducing the magnitude of that AC current to zero Amperes. The gradual reduction of alternating magnetic field strength from full to zero tends to randomize the magnetic domains in the ferrous core, returning it to an unmagnetized state.

Whatever the cause, CT saturation can be a significant problem for protective relay circuits because these relays must reliably operate under all manner of transient overcurrent events. The more current through the primary of a CT, the more current it should output to the protective relay. For any given amount of relay burden (relay input impedance), a greater current signal translates into a greater voltage drop and therefore a greater demand for the CT to output a driving voltage. Thus, CT saturation is more likely to occur during overcurrent events when we most need the CT to function properly. Anyone tasked with selecting an appropriate current transformer for a protective relaying application must therefore carefully consider the maximum expected value of overcurrent for system faults, ensuring the CT(s) will do their job while driving the burdens imposed by the relays.

2.6.4 Current transformer testing

Current transformers may be bench-tested for turns ratio and saturation⁹ by applying a variable AC voltage to the secondary winding while monitoring secondary current and primary voltage with meters. For common “window” style CTs, the primary winding is a single wire threaded through its center hole. An ideal current transformer would present a constant impedance to the AC voltage source and a constant voltage ratio from input to output. A real current transformer will exhibit less and less impedance as voltage is increased past its saturation threshold:

Testing a CT for ratio and saturation

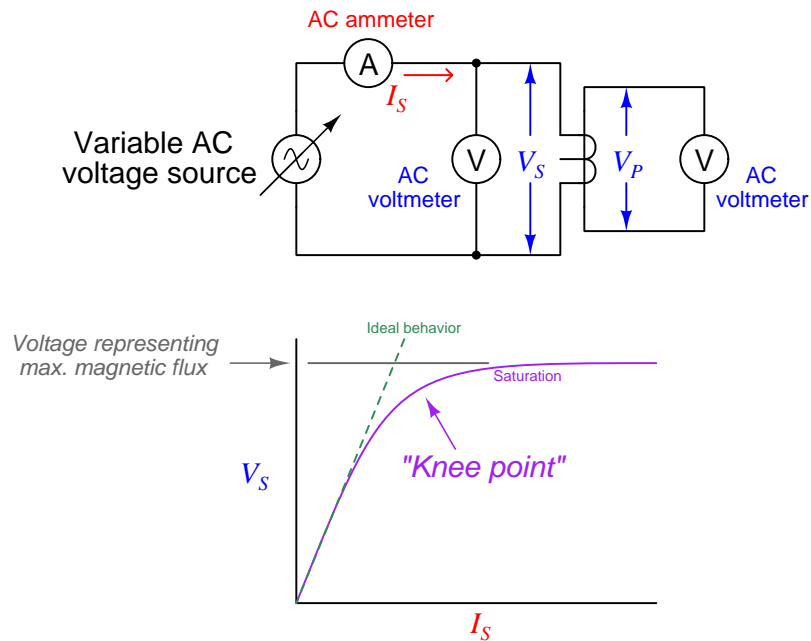

An ideal CT (with no saturation) would trace a straight line. The bent shape reveals the effects of magnetic saturation, where there is so much magnetism in the CT’s core that additional current only yields miniscule increases in magnetic flux (revealed by voltage drop).

Of course, a CT is never *powered* by its secondary winding when installed and operating. The purpose of powering a CT “backwards” as shown is to avoid having to drive very high currents through the primary of the CT. If high-current test equipment is available, however, such a *primary injection test* is actually the most realistic way to test a CT.

⁹In the electric power industry this is commonly referred to as a “rat/sat” test.

The following table shows actual voltage and current values taken during a secondary excitation test on a C400 class relay CT with a 2000:5 ratio. The source voltage was increased from zero to approximately 600 Volts AC at 60 Hz for the test while secondary voltage drop and primary voltage were measured using AC voltmeters. Around 575 Volts a “buzzing” sound could be heard coming from the CT – an audible effect of magnetic saturation. Calculated values of secondary winding impedance and turns ratio are also shown in this table:

I_S	V_S	V_P	$Z_S = V_S \div I_S$	Ratio = $V_S \div V_P$
0.0308 A	75.14 V	0.1788 V	2.44 k Ω	420.2
0.0322 A	100.03 V	0.2406 V	3.11 k Ω	415.8
0.0375 A	150.11 V	0.3661 V	4.00 k Ω	410.0
0.0492 A	301.5 V	0.7492 V	6.13 k Ω	402.4
0.0589 A	403.8 V	1.0086 V	6.86 k Ω	400.4
0.0720 A	500.7 V	1.2397 V	6.95 k Ω	403.9
0.0883 A	548.7 V	1.3619 V	6.21 k Ω	402.9
0.1134 A	575.2 V	1.4269 V	5.07 k Ω	403.1
0.1259 A	582.0 V	1.4449 V	4.62 k Ω	402.8
0.1596 A	591.3 V	1.4665 V	3.70 k Ω	403.2
0.2038 A	600.1 V	1.4911 V	2.94 k Ω	402.5

As you can see from this table, the calculated secondary winding impedance Z_S begins to drop dramatically as the secondary voltage exceeds 500 Volts (near the “knee” point of the curve). The calculated turns ratio appears remarkably stable – close to the ideal value of 400 for a 2000:5 CT – but one must remember this ratio is calculated on the basis of *voltage* and not current. Since this test does not compare primary and secondary currents, we cannot see the effects saturation would have on this CT’s current-sensing ability. In other words, this test reveals when saturation begins to take place, but it does not necessarily reveal how the CT’s current ratio is affected by saturation.

What makes the difference between a 2000:5 ratio CT with a relay classification of C400 and a 2000:5 ratio CT with a relay classification of C800 is not the number of turns in the CT’s secondary winding (N)¹⁰ but rather the amount of ferrous metal in the CT’s core. The C800 transformer, in order to develop upwards of 800 Volts to satisfy relay burden, must be able to sustain twice as much magnetic flux in its core than the C400 transformer, and this requires a magnetic core in the C800 transformer with (at least) twice as much flux-carrying capacity. All other factors being equal, the higher the burden capacity of a CT, the larger and heavier it must be due to the girth of its magnetic core.

¹⁰If you think carefully about this, you realize that the number of turns of wire in either CT must be identical, because there is only one “turn” of wire passing through the center of either CT. In order to achieve a 2000:5 ratio, you must have 400 turns of wire wrapped around the toroidal ferrous core per the 1 “turn” of wire passing through the center of that core.

2.6.5 Current transformer circuit wire resistance

The burden experienced by an operating current transformer is the total series impedance of the measuring circuit, consisting of the sum of the receiving instrument’s input impedance, the total wire impedance, and the internal secondary winding impedance of the CT itself. Legacy electromechanical relays, with their “operate” coils driven by CT currents, posed significant burden. Since the burden imposed by an electromechanical relay stems from the operation of a wire coil, this burden impedance is a complex quantity having both real (resistive) and imaginary (reactive) components. Modern digital relays with analog-to-digital converters at their inputs generally pose purely resistive burdens to their CTs, and those burden values are generally much less than the burdens imposed by electromechanical relays.

A significant source of burden in any CT circuit is the resistance of the wire carrying the CT’s output current to and from the receiving instrument. It is quite common for the total “loop” distance of a CT circuit to be several hundred feet or more if the CTs are located in remote areas of a facility and the protective relays are located in a central control room. For this reason an important aspect of protective relay system design is wire size (gauge), in order to ensure the total circuit resistance does not exceed the CT’s burden rating.

Larger-gauge wire has less resistance per unit length than smaller-gauge wire, all other factors being equal. A useful formula for approximating the resistance of copper wire is shown here:

$$R_{1000ft} = e^{0.232G-2.32}$$

Where,

R_{1000ft} = Approximate wire resistance in Ohms per 1000 feet of wire length

G = American Wire Gauge (AWG) number of the wire

AWG wire sizes, like most “gauge” scales, is inverse: a larger number represents a thinner wire. This is why the formula predicts a smaller R value for a larger G value. An easy example value to plug into this formula is the number 10 representing #10 AWG wire, a common conductor size for CT secondary circuits:

$$R_{1000ft} = e^{(0.232)(10)-2.32}$$

$$R_{1000ft} = e^{2.32-2.32}$$

$$R_{1000ft} = e^0 = 1 \Omega \text{ per 1000 feet}$$

Bear in mind that this result of 1 Ohm¹¹ wire resistance per 1000 feet of length applies to the *total circuit length*, not the distance between the CT and the receiving instrument. A complete CT secondary electrical circuit of course requires *two* conductors, and so 1000 feet of wire will be needed to cover 500 feet of distance between the CT and the instrument. Some sources cite #12 AWG wire as the minimum gauge to use for CT secondary circuits regardless of wire length.

¹¹Calculations based on the specific resistance of copper at 20 °C place 10 AWG wire at 0.9989 Ohms per 1000 feet. $R = \frac{\rho l}{A}$

2.6.6 Example: CT circuit wire sizing, simple

A practical example will help illustrate how wire resistance plays a role in CT circuit performance. Let us begin by considering a C400 accuracy class current transformer to be used in a protective relay circuit, the CT itself possessing a measured secondary winding resistance of 0.3Ω with a 600:5 turns ratio. By definition, a C400 current transformer is one capable of generating 400 Volts at its terminals while supplying 20 times its rated current to a burden. This means the maximum burden value is 4 Ohms, since that is the impedance which will drop 400 Volts at a secondary current of 100 Amperes (20 times the CT's nominal output rating of 5 Amperes):

C400 current transformer at 20 times rated current, maximum burden value

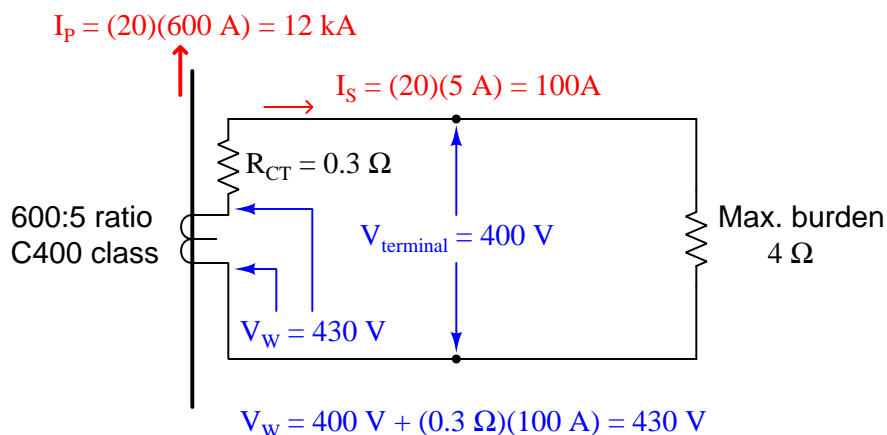

Although the CT has a C400 class rating which means 400 Volts (maximum) produced at its terminals, the winding must actually be able to produce more than 400 Volts in order to overcome the voltage drop of its own internal winding resistance. In this case, with a winding resistance of 0.3 Ohms carrying 100 Amperes of current (worst-case), the winding voltage must be 430 Volts in order to deliver 400 Volts at the terminals. This value of 430 Volts, at 60 Hz with a sinusoidal current waveform, represents the maximum amount of magnetic flux this CT's core can handle while maintaining a current ratio within $\pm 10\%$ of its 600:5 rating. Thus, 430 Volts (inside the CT) is our limiting factor for the CT's winding at *any* current value.

This step of calculating the CT's maximum internal winding voltage is not merely an illustration of how a CT's "C" class rating is defined. Rather, this is an essential step in any analysis of CT circuit burden because we must know the maximum winding potential the CT is limited to. One might be tempted to skip this step and simply use 400 Volts as the maximum terminal voltage during a fault condition, but doing so will lead to minor errors in a simple case such as this, and much more significant errors in other cases where we must de-rate the CT's winding voltage for reasons described later in this section.

Suppose this CT will be used to supply current to a protective relay presenting a purely resistive burden of 0.2 Ohms. A system study reveals maximum symmetrical fault current to be 10,000 Amperes, which is just below the 20× rated primary current for the CT. Here is what the circuit will look like during this fault condition with the CT producing its maximum (internal) voltage of 430 Volts:

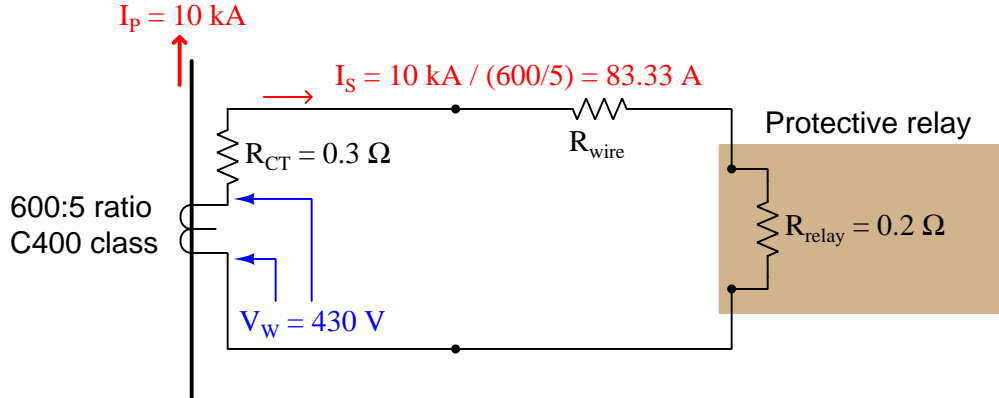

The CT's internal voltage limit of 430 Volts still holds true, because this is a function of its core's magnetic flux capacity and not line current. With a power system fault current of 10,000 Amperes, this CT will only output 83.33 Amperes rather than the 100 Amperes used to define its C400 classification. The maximum total circuit resistance is easily predicted by Ohm's Law, with 430 Volts (limited by the CT's magnetic core) pushing 83.33 Amperes (limited by the system fault current):

$$R_{total} = \frac{V_w}{I_{fault}} = \frac{430 \text{ V}}{83.33 \text{ A}} = 5.16 \Omega$$

Since we know the total resistance in this series circuit is the sum of CT winding resistance, wire resistance, and relay burden, we may easily calculate maximum wire resistance by subtraction:

$$R_{total} = R_{CT} + R_{wire} + R_{relay}$$

$$R_{wire} = R_{total} - (R_{CT} + R_{relay})$$

$$R_{wire} = 5.16 \Omega - (0.3 \Omega + 0.2 \Omega) = 4.66 \Omega$$

Thus, we are allowed to have up to 4.66 Ω of total wire resistance in this CT circuit while remaining within the CT's ratings. Assuming the use of 12 gauge copper wire:

$$R_{1000ft} = e^{(0.232)(12) - 2.32} = 1.59 \Omega \text{ per } 1000 \text{ feet}$$

$$\frac{4.66 \Omega}{1.59 \Omega / 1000 \text{ ft}} = 2.93 \times 1000 \text{ ft} = 2930 \text{ ft}$$

Of course, this is *total* conductor length, which means for a two-conductor cable between the CT and the protective relay the maximum distance will be half as much: 1465 feet.

2.6.7 Example: CT circuit wire sizing, with DC considered

The previous scenario assumes purely AC fault current. Real faults may contain significant DC components for short periods of time, the duration of these DC transients being related to the $\frac{L}{R}$ time constant of the power circuit. As previously mentioned, direct current tends to magnetize the ferrous core of a CT, predisposing it to magnetic saturation. Thus, a CT under these conditions will not be able to generate the full AC voltage possible during a controlled bench test (e.g. a C400 current transformer under these conditions will not be able to live up to its 400-volt terminal rating). A simple way to compensate for this effect is to de-rate the CT's winding voltage by a factor equal to $1 + \frac{X}{R}$, the ratio $\frac{X}{R}$ being the reactance-to-resistance ratio of the power system at the point of measurement. De-rating the transformer provides a margin of safety for our calculations, anticipating that a fair amount of the CT's magnetic core capacity may be consumed by DC magnetization during certain faults, leaving less magnetic "headroom" to generate an AC voltage.

Let's re-do our calculations assuming the power system being protected now has an $\frac{X}{R}$ ratio of 14. This means our C400 current transformer (with a maximum internal winding potential of 430 Volts) must be "de-rated" to a maximum winding voltage of:

$$\frac{430 \text{ V}}{1 + \frac{X}{R}} = \frac{430 \text{ V}}{1 + 14} = 28.67 \text{ V}$$

If we apply this de-rated winding voltage to the same CT circuit, we find it is insufficient to drive 83.33 Amperes through the relay:

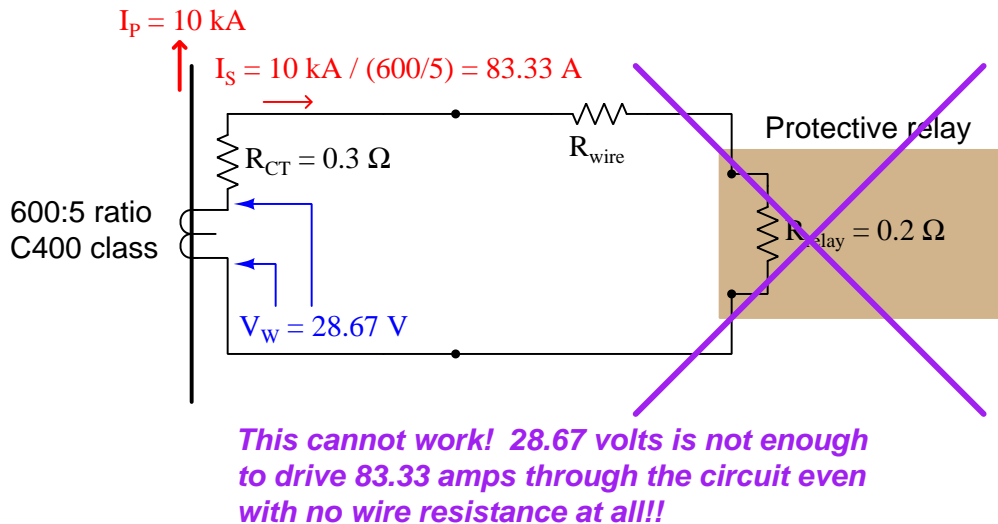

With 0.5Ω of combined CT and relay resistance (and no wire resistance), a winding voltage of 28.67 Volts could only drive 57.33 Amperes which is far less than we need. Clearly this CT will not be able to perform under fault conditions where DC transients push it closer to magnetic saturation.

Upgrading the CT to a different model having a higher accuracy class (C800) and a larger current step-down ratio (1200:5) will improve matters. Assuming an internal winding resistance of 0.7 Ohms for this new CT, we may calculate its maximum internal winding voltage as follows: if this CT is rated to supply 800 Volts at its terminals at 100 Amperes secondary current through 0.7 Ohms of internal resistance, it must mean the CT's secondary winding internally generates 70 Volts more than the 800 Volts at its terminals, or 870 Volts under purely AC conditions. With our power system's $\frac{X}{R}$ ratio of 14 to account for DC transients, this means we must de-rate the CT's internal winding voltage from 870 Volts to 15 times less, or 58 Volts. Applying this new CT to the previous fault scenario:

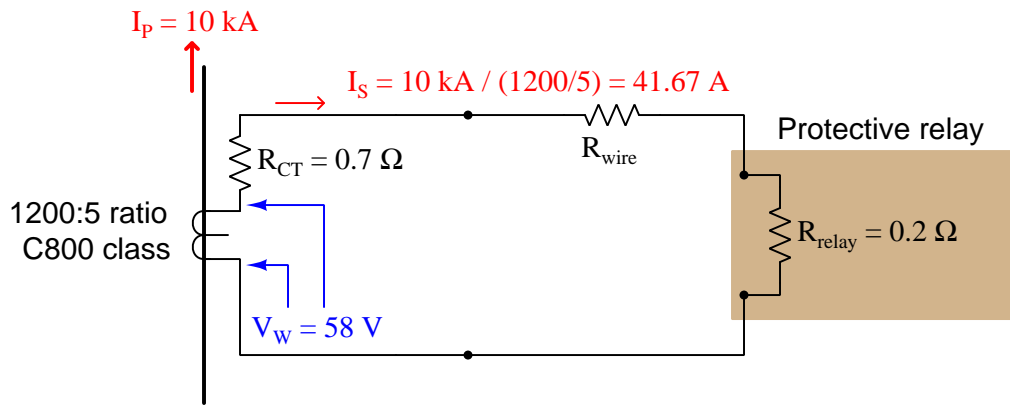

Calculating the allowable total circuit resistance given the new CT's improved voltage:

$$R_{total} = \frac{V_w}{I_{fault}} = \frac{58 \text{ V}}{41.67 \text{ A}} = 1.392 \Omega$$

Once again, we may calculate maximum wire resistance by subtracting all other resistances from the maximum total circuit resistance:

$$R_{wire} = R_{total} - (R_{CT} + R_{relay})$$

$$R_{wire} = 1.392 \Omega - (0.7 \Omega + 0.2 \Omega) = 0.492 \Omega$$

Thus, we are allowed to have up to 0.492 Ω of wire resistance in this circuit while remaining within the CT's ratings. Using 10 AWG copper wire (exhibiting 1 Ohm per 1000 feet), this allows us a total conductor length of 492 feet, which is 246 feet of distance between the CT terminals and the relay terminals.

Chapter 3

Historical References

This chapter is where you will find references to historical texts and technologies related to the module's topic.

Readers may wonder why historical references might be included in any modern lesson on a subject. Why dwell on old ideas and obsolete technologies? One answer to this question is that the initial discoveries and early applications of scientific principles typically present those principles in forms that are unusually easy to grasp. Anyone who first discovers a new principle must necessarily do so from a perspective of ignorance (i.e. if you truly *discover* something yourself, it means you must have come to that discovery with no prior knowledge of it and no hints from others knowledgeable in it), and in so doing the discoverer lacks any hindsight or advantage that might have otherwise come from a more advanced perspective. Thus, discoverers are forced to think and express themselves in less-advanced terms, and this often makes their explanations more readily accessible to others who, like the discoverer, comes to this idea with no prior knowledge. Furthermore, early discoverers often faced the daunting challenge of explaining their new and complex ideas to a naturally skeptical scientific community, and this pressure incentivized clear and compelling communication. As James Clerk Maxwell eloquently stated in the Preface to his book *A Treatise on Electricity and Magnetism* written in 1873,

It is of great advantage to the student of any subject to read the original memoirs on that subject, for science is always most completely assimilated when it is in its nascent state . . . [page xi]

Furthermore, grasping the historical context of technological discoveries is important for understanding how science intersects with culture and civilization, which is ever important because new discoveries and new applications of existing discoveries will always continue to impact our lives. One will often find themselves impressed by the ingenuity of previous generations, and by the high degree of refinement to which now-obsolete technologies were once raised. There is much to learn and much inspiration to be drawn from the technological past, and to the inquisitive mind these historical references are treasures waiting to be (re)-discovered.

3.1 Early instrument transformer safety

A fascinating historical reference on protective relay systems is Victor Todd's *Protective Relays – their theory, design, and practical operation* published in 1922. One quotation in particular discusses the hazards of open-circuiting an operating current transformer (CT):

Opening of Secondary. – The secondary circuit of a current transformer should never be opened while the primary is carrying current. If it is necessary to disconnect instruments the secondary should first be short-circuited. If the secondary circuit is opened, a difference of potential is developed between terminals which is dangerous to anyone coming into contact with the meters or leads. The cause of this high voltage is that with open secondary circuit all of the primary ampere-turns are effective in producing flux in the core, whereas normally but a very small portion of the total perform this function. The danger is magnified by the fact that the wave form of this secondary voltage is peaked, producing a high-maximum value. A high flux produced in this way may also permanently change the magnetic condition of the core so that the accuracy of the transformer will be impaired. [page 122]

As we see, the danger is not only of a personal sort, but also that the CT could be damaged by permanent magnetization of its iron core should it be open-circuited under load.

Chapter 4

Derivations and Technical References

This chapter is where you will find mathematical derivations too detailed to include in the tutorial, and/or tables and other technical reference material.

4.1 Electrical safety

A subject of extreme importance to all electrical practitioners is electrical *safety*, with Ohm's and Joule's Laws being excellent starting points for a discussion on that topic. Here we examine the human body as an electrical *load*: electrical charge carriers passing through the resistance of the body from an external source relinquish some of their energy in the same way charge carriers lose energy passing through any other resistance. The rate of energy dissipation (i.e. *power*) through the body's resistance is predicted by Joule's Law, $P = I^2R$. The total amount of energy delivered to a body by an electric current is a function of that power dissipation rate multiplied by the amount of time current flowed¹.

Electrical energy poses two distinctly different threats to any living body: the first threat is forced activation of the body's nervous system by electric current passing through nerve cells, and the second threat is burning from the thermal power dissipated in flesh and bone. Both threats are direct functions of the amount of energy delivered to the body, with the first effect (called *electric shock*) beginning at lower levels of current than the second effect.

Electric shock – not to be confused with the general condition of *circulatory shock* characterized by reduced blood circulation in the body – first manifests as a tingling sensation, then as pain with greater electric current intensity. At a certain threshold value, the current will be sufficient to override voluntary muscle control. At higher levels of current, breathing will become difficult or may cease due to paralysis of the diaphragm muscles within the chest. At even higher levels of current, the heart (itself a muscle of the body) will either fall into an arrhythmic beat pattern or cease beating altogether. *All of these effects will occur at current levels significantly less than one Ampere.*

Some of the most detailed data we possess on the effects of electric shock come from the research of University of California Berkeley Professor Charles Dalziel, who in the year 1961 published a report entitled “Deleterious Effects of Electric Shock”. Dalziel performed electric shock experiments on human volunteers, subjecting both males and females to varying degrees of electric current, both direct (DC) and alternating (AC), for the purpose of determining thresholds of sensation, pain, and loss of muscular control.

Table II of Dalziel's' report (shown on page 24) is partially² reproduced in the following table. The headings “M” and “F” refer to male and female subjects, respectively. Tests conducted using direct current³ are labeled “DC” while tests conducted using alternating current⁴ are labeled with

¹Putting units of measurement to this concept, the amount of energy in *Joules* is equal to average power in *Joules per second* multiplied by time in *seconds*, with the unit of “seconds” canceling out. For brief exposures to electricity, such as lightning strikes, the most important measurement with regard to safety is the total energy delivered to the body. The same is true for deliberate applications of electricity to the body, for example cardiac defibrillators, where the machine's setting is calibrated in Joules of energy delivered per impulse.

²The original Table II contained a column of data representing thresholds for women at 10 kHz alternating current, but these were estimations and not actual data. Extrapolating from the other data points where women tended to exhibit the same effects as men at approximately $\frac{2}{3}$ the current, Dalziel writes, “*Tests on women were not made on frequencies other than 60 cycles, but if it is assumed that the response for women would be similar, values for women can be estimated at two-thirds of the corresponding value for men.*” Readers should note that I have taken editorial liberties with the description of bodily effects, for no reason other than formatting.

³Direct current, or DC, refers to a continuous flow of electric charge carriers in one direction only.

⁴Alternating current, or AC, refers to an electric current that periodically switches direction, the period of that

frequency values expressed in the unit of Hertz (Hz) or cycles per second. All data points are expressed in *milliAmperes* (mA), one milliAmpere being $\frac{1}{1000}$ of an Ampere:

Bodily effect	DC, M	DC, F	60 Hz, M	60 Hz, F	10 kHz, M
Slight sensation felt on hand	1 mA	0.6 mA	0.4 mA	0.3 mA	7 mA
Median perception threshold	5.2 mA	3.5 mA	1.1 mA	0.7 mA	12 mA
Shock, with no loss of muscular control	9 mA	6 mA	1.8 mA	1.2 mA	17 mA
Pain, with 50% of subjects losing muscular control	62 mA	41 mA	9 mA	6 mA	55 mA
Pain, labored breathing, 99.5% of subjects losing muscular control	90 mA	60 mA	23 mA	15 mA	94 mA

For rather obvious reasons no human tests were conducted to the point of cardiac fibrillation. Dalziel's report does, however, provide data collected on a variety of animals (pigs, sheep, calves, dogs, cats, guinea pigs, rabbits) which were anesthetized and then administered large amounts of electric current until their hearts malfunctioned. From this admittedly limited data, Dalziel extrapolated the values to obtain 500 mA ($\frac{1}{2}$ Ampere) of direct current and 100 mA ($\frac{1}{10}$ Ampere) of alternating current as thresholds for "possible" human heart fibrillation following a three-second electric shock.

All gruesome details aside, the lesson to be learned here is very plain: *very little electric current is necessary to induce painful and even life-threatening effects on the human body!* These danger thresholds are all substantially less than the amount of current most power conductors are rated to handle, and less than the ratings of fuses and circuit breakers designed to protect conductors from overheating.

switching measured in cycles per second or Hertz. In North America, the standard AC grid power frequency is 60 cycles per second, or 60 Hz. The second AC frequency used in Dalziel's experiments is 10 kHz, which is 10 *kilo*-Hertz, or 10000 cycles per second.

The first line of defense against electrical shock is to place as much electrical resistance between your body and the circuit's conductors as is practical, as a means of impeding the flow of electric current to and through your body. Turning "off" any disconnecting switches between the circuit and its energy source is a simple means to do this, essentially inserting an air gap between the circuit and its normal source of power. This allows all points within the circuit to achieve an equipotential state, which may then be made equipotential to your body by connection to Earth ground (where you are standing). If there is no voltage present (i.e. no difference in the potential energy levels of electric charge carriers at different points), then there should be no possibility of dissipating electrical energy into your body.

Once all electrical energy sources have been disconnected from the circuit you intend to work on, an additional safety measure is to *bond* that circuit's power conductors to Earth ground. This step forces the power conductors to be *electrically common* with Earth, and therefore guarantees a condition of equipotentiality with the Earth. Line workers who install and maintain electric power line conductors do this as a standard part of their operating procedure: attaching temporary grounding cables between the power conductors and Earth after opening all disconnect switches normally connecting those lines to electrical sources. This extra step of bonding the power conductors ensures no stray sources⁵ of electrical energy may pose a threat.

The following photograph shows a work site at a 230 kV (230,000 Volt!) electrical substation, where electricians are busy performing maintenance work on a high-voltage component. In addition to opening large switches (called *disconnects*) to isolate this new component from any source of voltage, they have taken the additional step of *bonding* the high-voltage conductors to each other and to Earth ground by means of temporary wire cables. The cables on this work site happen to be yellow in color, and may be seen hanging down from C-shaped clamps attached to three horizontal metal tubes called *busbars* which serve as conductors for electricity in this substation:



⁵Examples include electrostatic or magnetic "coupling" with adjacent energized power lines, nearby lightning strikes, etc.

Obviously, such measures are quite necessary on high-voltage systems such as substation busbars – there simply is no safe way to work on energized conductors at this voltage level. However, in lower-voltage circuits it is often necessary to take electrical measurements and make certain adjustments while the circuit is in an energized state. If the circuit in question cannot be “killed” by disconnection of its power source and therefore must be worked on “live”, the next best protective measure is to layer insulating material on your body where contact might otherwise be made to permit an electric current through it. This means wearing insulating gloves and shoes, at minimum. The principle behind this technique is Ohm’s Law: for any given amount of voltage (V), current (I) will be inversely proportional to the total resistance (R) of the circuit pathway. Layering electrically insulating material over your body’s possible points of contact (e.g. hands, feet) increases the total resistance of the circuit pathway, and therefore minimizes the amount of current that may flow in the event of physical contact between two points where a substantial voltage exists.

Lastly, in order to minimize the risk of electric current passing through one’s chest (where the heart and diaphragm muscles are located), a wise habit when working on energized circuits is to place one hand in a pocket so that only one hand is in use. This will not only prevent arm-to-arm passage of electric current, but it also minimizes the number of potential points of contact with bare skin. Electrical practitioners commonly refer to this as the *One-Hand Rule*. Ideally, the best hand to place in a pocket is the left hand, because this is the side of the body where the heart is most vulnerable.

It is worth noting that the danger from electric shock is best quantified in terms of current, not voltage, since it is electric current that activates nerve cells. The amount of current passing through a victim’s body from an applied voltage is a function of Ohm’s Law ($I = \frac{V}{R}$), and since resistance (R) varies greatly with skin dryness and layering provided by shoes and clothing, it is difficult to predict how much voltage poses a shock hazard. A generally accepted threshold of danger is 30 Volts, but this assumes direct contact with dry skin. Moist skin, perspiration, cuts or punctures, and other factors reducing body resistance may greatly reduce the voltage threshold for shock hazard! Another factor is the general health of the victim prior to receiving the electric shock. A preexisting cardiac condition will likely predispose that individual to harm resulting from an electric shock.

Burns produced by electricity passing through the body may manifest on the skin, at the point of contact with an electrical conductor (such as a wire), or in severe cases may extend to internal organs. Comparing internal flesh with skin, dry human skin tends to exhibit much greater levels of electrical resistance than the internal organs which are wet. This is why electricity causes skin-surface burns before causing internal organ burns: for any given amount of electric current passing through different resistances, power dissipated by that current will be greatest at the area greatest resistance. Mathematically stated, P is maximized where R is greatest, given any value of (I), in accordance with Joule’s Law (I^2R).

Another mechanism of electrically-caused burns is *arc flash*: the heating of air by the passage of electric current through it (rather than through the body). Under normal conditions air is an extremely good insulator of electricity, with no free charge carriers available to sustain an electric current. However, when sufficient voltage causes the electrons in air molecules to separate from their respective atoms, the negatively-charged electrons and positively-charged ions constitute charge carriers, and will form an electric current called either a *spark* or an *arc*. This current heats the air molecules by dissipating power as described by Joule’s Law ($P = I^2R$), with I being the magnitude of current traveling through the ionized air and R being the resistance of the arc path.

The amount of resistance exhibited by a high-temperature arc is surprisingly low, typically less than one Ohm across the entire length of the arc. With such low resistance, Ohm's Law predicts relatively high current values for even modest voltages ($I = \frac{V}{R}$), resulting in high power levels. Even if the amount of energy released by each charge carrier moving through the arc is small, the fact that a great many charge carriers are moving through the arc each second means that the total amount of energy dissipated may be phenomenally large. This is why arcs forming in high-voltage electric power systems may reach temperatures of tens of thousands of degrees⁶!

In the United States of America, a widely respected standard document for electrical hazards and protection is the National Fire Protection Association (NFPA) standard 70E. This document rates both electric shock and arc flash hazards for electric power circuits based on voltage and current capabilities, as well as specifies best practices for protection against those hazards.

An example of NFPA 70E standards applied to an industrial installation is the following pair of photographs showing warning labels affixed to metal-clad electrical switchgear (i.e. metal cabinets housing large circuit breakers). Each label cites both arc flash and electric shock hazards, including *boundary* distances within which greater hazards exist:

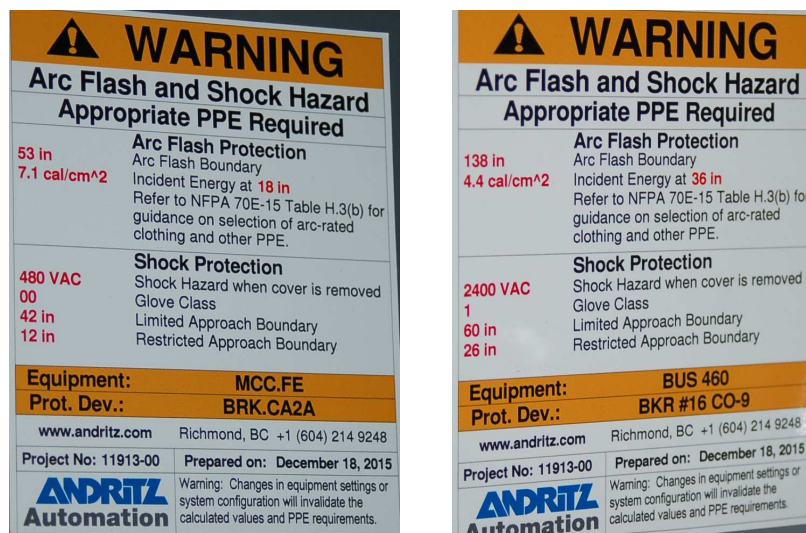

The first line of defense against arc flash is the same as for electric shock: *de-energize the circuit* so there will be no electrical energy present to harm you. The procedure for de-energizing includes placing a warning *tag* as well as a secure *lock* on any main disconnecting switches or circuit breakers to ensure power does not get accidentally applied to the circuit while people are in harm's way. This is referred to in industry as *lock-out, tag-out, or LOTO*.

⁶The NFPA 70E electrical safety standard (Informative Annex K) cites temperatures as high as 35,000 degrees Fahrenheit in arc flash events, and states that such events are lethal at distances up to 10 feet (3.05 meters). It is worth noting that electric arc temperatures are limited only by the rate of power dissipated in the arc. Unlike chemically-driven combustion events, where temperature is limited by the rate at which the various chemical reactants are able to combine, no such limiting factor exists with electric arcs: the more power dissipated in the arc, the hotter it will become. These temperatures involved with electric power faults can be so high that they *vaporize* the metal wires!

Generally accepted lock-out, tag-out procedures for electrical equipment include (but are not limited to) the following steps:

1. Turn equipment off using regular on/off switch to interrupt load current
2. Open all disconnect switches and/or circuit breakers feeding electrical power to the equipment
3. Visually confirm (if possible) that *all* poles of the disconnecting switch(es) are open
4. Attempt to re-start equipment as your first confirmation that power is indeed shut off
5. Attach locks and tags to prevent disconnecting switches from being re-closed; if no lockable disconnect means exists, you must open and tag *two* or more redundant disconnects!
6. Confirm proper operation of voltage meter against a known source
7. Test for dangerous voltage between all relevant conductors, especially those you could bodily contact, including between pairs of phase conductors in a polyphase system as well as between each phase conductor and earth ground
8. Confirm (again) proper operation of voltage meter against a known source

Such a lengthy procedure may seem paranoid, but there is good reason for all these steps. Remember that *all safety standards and procedures are written in blood*: in other words, every one of them exists because either someone got hurt or came close to getting hurt by not taking appropriate precautions. One example of the latter is the following photograph generously shared by Jim Lyon⁷ who discovered a failed three-phase disconnect switch during a routine LOTO procedure:



As you can see in this photograph, one of the linkages between the disconnecting switch pole and the actuating lever has broken, allowing one phase to remain closed while the other two opened as they should. Such a failure would neither be apparent to the operator of that switch nor by anyone's external inspection of it, but would be revealed by proper voltage testing (phase-to-ground) on that faulted phase conductor. Had Mr. Lyon simply trusted the switch handle's "off" position as proof of a zero-energy state, he could have been electrocuted touching the un-opened conductor "downstream" of the switch.

⁷Mr. Lyon granted me permission to include his safety-related photographs in my open-source writings during an exchange on the professional social-media website [LinkedIn](#).

Another important note with regard to electrical safety and LOTO is the proper function of your test equipment. Multimeters and test leads are not just tools for precision measurement, but are life-saving indicators of dangerous voltage. I have personally witnessed multiple instances of failed multimeter test leads, where one or more leads failed open such that the meter could not reliably register the presence of voltage. This is why good LOTO procedure always includes verification of the meter both *before and after* checking for dangerous voltages at the system conductors.

In cases where de-energization is not possible or not practical, special “arc-flash rated” clothing may be worn to protect your skin against the high temperatures of arc flash should an arc flash occur. Arc flash suits cover all skin surfaces, and are rated according to the number of calories⁸ of heat the fabric may sustain without disintegrating. The following photograph shows a pair of arc flash suits hanging on a wall ready for electricians to use while working on circuit breakers at an electric power generating station:



The blue-colored hood covers the worker’s head and neck, while the grey-colored jumpsuit covers the rest of the worker’s body.

⁸A *calorie* is simply another unit of energy measurement. The unit-conversion equivalence is 4.187 Joules per calorie.

The hazards of electrical arcs are not limited to bodily burns. Given sufficient arc power, the explosive expansion of hot air and the shrapnel created by disintegrating hardware represents its own unique hazard, known as *arc blast*. As an *electrically-driven* explosion⁹, arc blast is limited only by the available power of the fault, and can in fact be more violent than a chemical explosion. No suit can ensure safety against arc blast, and so the only reasonable precaution is maintaining a safe distance beyond the blast radius.

⁹The concussive effects of an arc blast originate from the rapid expansion of air and vaporized metal, producing intense sound waves and blast pressures. Extremely bright light, as well as high temperatures caused by convection of super-heated air and by radiation of infrared light from the arc are capable of creating third-degree burns on unprotected skin.

4.2 Transformer parasitics

An ideal transformer couples electrical energy from its primary winding to its secondary winding(s) with no energy loss (i.e. dissipation) and with no additional impedance standing in the way of that energy transfer. When unloaded, an ideal transformer draws no current whatsoever from its connected source. Real transformers, however, fall quite short of these ideal characteristics. The following diagram models some of the parasitic effects observed in real transformers:

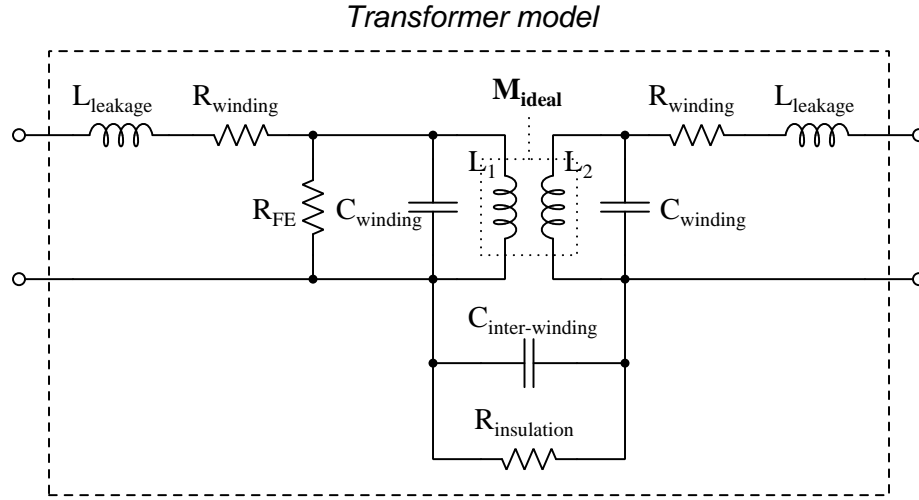

Each of the transformer's windings have resistance owing to the specific resistance of the metal making up those wire windings, this winding resistance effectively being in series with each winding. Additionally, each winding has *leakage inductance* which is the result of magnetic flux that does not couple between the two windings but instead merely stores and releases energy like the self-inductance of a single inductor. Together, winding resistance and leakage inductance contribute to the *impedance* of the transformer, limiting its ability to seamlessly transfer energy from primary to secondary circuits.

We also see each winding suffering from capacitance, resulting from the insulation between adjacent turns of wire. The presence of this parasitic capacitance, something found in every inductor as well as in transformers, means the primary and secondary windings are able to *self-resonate* at certain frequencies. Note also that there is capacitance coupling between the primary and secondary windings, which means no transformer can ever *perfectly* isolate the primary and secondary circuits from each other.

Lastly we have a resistance shown in the model as R_{FE} representing dissipative losses in the iron core material from effects such as hysteresis and magnetostriction. This is often referred to as *iron loss* (as opposed to the *copper loss* of winding resistance).

Next we will explore common mechanisms for each of these effects.

4.2.1 Parasitic resistance in transformers

Winding resistance depends on the size and composition of wire used to make each winding. Using low-resistivity metal and wire of sufficiently large gauge are really the only ways to minimize this parasitic effect. Using a transformer with over-sized wire (i.e. a transformer having current ratings in excess of the currents expected in your application) is one way to reduce this parasitic effect using commonly-available transformers.

So-called “iron loss” resistance is based on magnetic effects, primarily the hysteresis curve for the iron alloy. Modern silicon-steel alloys formulated for transformer applications enjoy very narrow B-H hysteresis curves which in turn translate to low levels of energy dissipation as the core magnetizes in one polarity, de-magnetizes, and re-magnetizes in the other polarity with each cycle of the energizing AC. Using a transformer with an over-sized magnetic core has the result of dispersing the magnetic flux over a larger cross-sectional area, resulting in less magnetic flux density (B) with all other factors being equal. One way to specify a transformer with an over-sized magnetic core is to select one with a higher voltage rating than your application strictly needs, as peak magnetic flux density for any given AC frequency is a function of the peak voltage experienced by each winding. If frequency is not variable, then the cycle time (period) of the AC waveform will likewise be fixed, and since total magnetic flux in any inductor is the integral of voltage and time (i.e. the *Volt-second product*) it means a transformer with a higher voltage rating must possess a larger magnetic core.

4.2.2 Leakage inductance in transformers

Leakage inductance, another contributing factor of transformer impedance, results from some of the core’s magnetic flux not coupling perfectly between primary and secondary windings. Core shape and material choice affect this parameter, with toroidal transformer cores generally performing better than cores having abrupt corners.

4.2.3 Parasitic capacitance in transformers

Capacitance unavoidably exists between adjacent turns of wire in any inductor, and also between adjacent turns of primary and secondary windings in a transformer. Reducing turn-to-turn parasitic capacitance within any single winding requires those turns be spaced farther apart from each other, or wound in different patterns, or with an insulating material having a lower dielectric permittivity.

Primary-to-secondary winding capacitance can be mitigated to a large extent by placing an electrostatic *shield* between the two windings of the transformer and connecting that shield conductor to Earth ground. This works precisely the same way as wrapping a foil or braided shield conductor around a multi-conductor cable in order to shield those conductors from electric fields external to the cable. In this case, the shielding stops electric flux lines from linking from one winding to another. Shielded-winding transformers are more expensive to manufacture than their unshielded counterparts.

Another mitigation technique for primary-to-secondary parasitic capacitance is to use a *split-bobbin* transformer where the primary and secondary windings do not overlap each other, but rather are placed at different locations around the magnetic “circuit” formed by the iron core. This increases the separation distance between these two windings without significantly affecting other performance parameters of the transformer, but of course has the effect of increasing the over-all size of the transformer.

4.2.4 Excitation and magnetization currents

As described at the beginning of this section, an ideal transformer draws no current whatsoever from its energizing source. This, however, is possible only by meeting two idealized conditions:

- The primary winding inductance must be infinite
- Magnetic core losses must be zero (i.e. a lossless core)

An infinite primary winding inductance is simply impossible to achieve in any real transformer, though we may approach this ideal by building transformers whose primary inductance values are quite large. Large primary inductance means large values of inductive reactance ($X_L = 2\pi fL$), and so the larger the winding's inductance is the less *magnetization current* it will need to draw from an AC voltage source to create a rate-of-change of magnetic flux in the core sufficient to balance the applied source voltage as per Faraday's Law of Electromagnetic Induction ($V = N \frac{d\phi}{dt}$).

A lossless core material is similarly impossible to achieve in most real transformers, as all ferromagnetic materials invariably dissipate at least *some* energy when magnetized and demagnetized, and air/vacuum-core transformers become impractically large for typical AC power system frequencies (in order to achieve large amounts of inductance, as necessitated above).

Referencing our transformer model showing various parasitic and ideal effects, magnetization current is that amount of current drawn by ideal primary inductance L_1 when the secondary is unloaded (i.e. open-circuited). This, combined with the current drawn from the AC voltage source as a result of the iron losses (R_{FE}), is called *excitation current*. Thus, $I_{excite} = I_{L_1} + I_{R_{FE}}$ which is a phasor current sum, I_{L_1} lagging the applied voltage by 90° and $I_{R_{FE}}$ being in-phase with the applied voltage. If the excitation current is measured using an instrument such as an oscilloscope capable of comparing phase angles between the measured current and the applied voltage, magnetization current will be the imaginary portion of the excitation current while core-loss current will be the real portion.

4.2.5 Transformer testing

The following list shows typical tests for transformers at the time of manufacture:

- **DC winding resistances** – the simplest of these to measure, using a multimeter
- **Winding inductances/impedances** – performed by exciting one winding with an AC source and comparing voltage/current, typically using either an LCR meter or an impedance analyzer
- **Turns ratio** – performed by exciting one winding with an AC current source and measuring another winding’s short-circuited current using an AC ammeter
- **Winding polarity/phase-shift** – performed by exciting one winding with an AC voltage and measuring another winding’s induced voltage, an oscilloscope used to compare the phases of each voltage
- **Core saturation** – performed by exciting one winding with a sinusoidal AC current and measuring another winding’s induced voltage until a non-sinusoidal waveshape is detected, or more crudely by determining when the induced voltage no longer increases proportionately to increased excitation current
- **Excitation current** – performed by exciting one winding with an AC voltage and measuring current drawn by that winding
- **Insulation resistance** – performed with a “Hi-Pot” (high-potential) insulation tester, generally connecting one terminal to both ends of one winding and the other tester terminal to both ends of another winding, this infers insulation resistance by applying (typically) several thousand Volts DC while measuring the small current passing through the stressed insulation

A more thorough battery of tests used during transformer design development might include the following:

- **Linearity** – turns ratio testing performed at several different amounts of excitation current, checking to see how consistent the effective turns ratio is over a wide range
- **BH loop** – performed by exciting one winding with an AC voltage and measuring the voltage induced in another winding, that induced voltage representing the rate-of-change of magnetic flux which may be mathematically integrated to infer the amount of magnetic flux, those two variables being plotted using an oscilloscope’s X-Y mode much like “curve tracing” for a semiconductor component
- **High-voltage impulse** – similar to an insulation resistance test, this uses a high-voltage DC pulse applied across one winding to stress turn-to-turn insulation resistance
- **Volt-second** – performed by applying a DC voltage pulse to one winding while measuring current through it, the ideal response being a linear-ramping current whose magnitude is proportional to the Volt-second product of the applied pulse
- **Overload** – subjecting a winding to dramatic overcurrent to thermally and mechanically stress the transformer as it might be in an overloaded power system scenario

Chapter 5

Questions

This learning module, along with all others in the ModEL collection, is designed to be used in an inverted instructional environment where students independently read¹ the tutorials and attempt to answer questions on their own *prior* to the instructor's interaction with them. In place of lecture², the instructor engages with students in Socratic-style dialogue, probing and challenging their understanding of the subject matter through inquiry.

Answers are not provided for questions within this chapter, and this is by design. Solved problems may be found in the Tutorial and Derivation chapters, instead. The goal here is *independence*, and this requires students to be challenged in ways where others cannot think for them. Remember that you always have the tools of *experimentation* and *computer simulation* (e.g. SPICE) to explore concepts!

The following lists contain ideas for Socratic-style questions and challenges. Upon inspection, one will notice a strong theme of *metacognition* within these statements: they are designed to foster a regular habit of examining one's own thoughts as a means toward clearer thinking. As such these sample questions are useful both for instructor-led discussions as well as for self-study.

¹Technical reading is an essential academic skill for any technical practitioner to possess for the simple reason that the most comprehensive, accurate, and useful information to be found for developing technical competence is in textual form. Technical careers in general are characterized by the need for continuous learning to remain current with standards and technology, and therefore any technical practitioner who cannot read well is handicapped in their professional development. An excellent resource for educators on improving students' reading prowess through intentional effort and strategy is the book *Reading For Understanding – How Reading Apprenticeship Improves Disciplinary Learning in Secondary and College Classrooms* by Ruth Schoenbach, Cynthia Greenleaf, and Lynn Murphy.

²Lecture is popular as a teaching method because it is easy to implement: any reasonably articulate subject matter expert can talk to students, even with little preparation. However, it is also quite problematic. A good lecture always makes complicated concepts seem easier than they are, which is bad for students because it instills a false sense of confidence in their own understanding; reading and re-articulation requires more cognitive effort and serves to verify comprehension. A culture of teaching-by-lecture fosters a debilitating dependence upon direct personal instruction, whereas the challenges of modern life demand independent and critical thought made possible only by gathering information and perspectives from afar. Information presented in a lecture is ephemeral, easily lost to failures of memory and dictation; text is forever, and may be referenced at any time.

GENERAL CHALLENGES FOLLOWING TUTORIAL READING

- Summarize as much of the text as you can in one paragraph of your own words. A helpful strategy is to explain ideas as you would for an intelligent child: as simple as you can without compromising too much accuracy.
- Simplify a particular section of the text, for example a paragraph or even a single sentence, so as to capture the same fundamental idea in fewer words.
- Where did the text make the most sense to you? What was it about the text's presentation that made it clear?
- Identify where it might be easy for someone to misunderstand the text, and explain why you think it could be confusing.
- Identify any new concept(s) presented in the text, and explain in your own words.
- Identify any familiar concept(s) such as physical laws or principles applied or referenced in the text.
- Devise a proof of concept experiment demonstrating an important principle, physical law, or technical innovation represented in the text.
- Devise an experiment to disprove a plausible misconception.
- Did the text reveal any misconceptions you might have harbored? If so, describe the misconception(s) and the reason(s) why you now know them to be incorrect.
- Describe any useful problem-solving strategies applied in the text.
- Devise a question of your own to challenge a reader's comprehension of the text.

GENERAL FOLLOW-UP CHALLENGES FOR ASSIGNED PROBLEMS

- Identify where any fundamental laws or principles apply to the solution of this problem, especially before applying any mathematical techniques.
- Devise a thought experiment to explore the characteristics of the problem scenario, applying known laws and principles to mentally model its behavior.
- Describe in detail your own strategy for solving this problem. How did you identify and organized the given information? Did you sketch any diagrams to help frame the problem?
- Is there more than one way to solve this problem? Which method seems best to you?
- Show the work you did in solving this problem, even if the solution is incomplete or incorrect.
- What would you say was the most challenging part of this problem, and why was it so?
- Was any important information missing from the problem which you had to research or recall?
- Was there any extraneous information presented within this problem? If so, what was it and why did it not matter?
- Examine someone else's solution to identify where they applied fundamental laws or principles.
- Simplify the problem from its given form and show how to solve this simpler version of it. Examples include eliminating certain variables or conditions, altering values to simpler (usually whole) numbers, applying a limiting case (i.e. altering a variable to some extreme or ultimate value).
- For quantitative problems, identify the real-world meaning of all intermediate calculations: their units of measurement, where they fit into the scenario at hand. Annotate any diagrams or illustrations with these calculated values.
- For quantitative problems, try approaching it qualitatively instead, thinking in terms of “increase” and “decrease” rather than definite values.
- For qualitative problems, try approaching it quantitatively instead, proposing simple numerical values for the variables.
- Were there any assumptions you made while solving this problem? Would your solution change if one of those assumptions were altered?
- Identify where it would be easy for someone to go astray in attempting to solve this problem.
- Formulate your own problem based on what you learned solving this one.

GENERAL FOLLOW-UP CHALLENGES FOR EXPERIMENTS OR PROJECTS

- In what way(s) was this experiment or project easy to complete?
- Identify some of the challenges you faced in completing this experiment or project.

- Show how thorough documentation assisted in the completion of this experiment or project.
- Which fundamental laws or principles are key to this system's function?
- Identify any way(s) in which one might obtain false or otherwise misleading measurements from test equipment in this system.
- What will happen if (component X) fails (open/shorted/etc.)?
- What would have to occur to make this system unsafe?

5.1 Conceptual reasoning

These questions are designed to stimulate your analytic and synthetic thinking³. In a Socratic discussion with your instructor, the goal is for these questions to prompt an extended dialogue where assumptions are revealed, conclusions are tested, and understanding is sharpened. Your instructor may also pose additional questions based on those assigned, in order to further probe and refine your conceptual understanding.

Questions that follow are presented to challenge and probe your understanding of various concepts presented in the tutorial. These questions are intended to serve as a guide for the Socratic dialogue between yourself and the instructor. Your instructor’s task is to ensure you have a sound grasp of these concepts, and the questions contained in this document are merely a means to this end. Your instructor may, at his or her discretion, alter or substitute questions for the benefit of tailoring the discussion to each student’s needs. The only absolute requirement is that each student is challenged and assessed at a level equal to or greater than that represented by the documented questions.

It is far more important that you convey your *reasoning* than it is to simply convey a correct answer. For this reason, you should refrain from researching other information sources to answer questions. What matters here is that *you* are doing the thinking. If the answer is incorrect, your instructor will work with you to correct it through proper reasoning. A correct answer without an adequate explanation of how you derived that answer is unacceptable, as it does not aid the learning or assessment process.

You will note a conspicuous lack of answers given for these conceptual questions. Unlike standard textbooks where answers to every other question are given somewhere toward the back of the book, here in these learning modules students must rely on other means to check their work. The best way by far is to debate the answers with fellow students and also with the instructor during the Socratic dialogue sessions intended to be used with these learning modules. Reasoning through challenging questions with other people is an excellent tool for developing strong reasoning skills.

Another means of checking your conceptual answers, where applicable, is to use circuit simulation software to explore the effects of changes made to circuits. For example, if one of these conceptual questions challenges you to predict the effects of altering some component parameter in a circuit, you may check the validity of your work by simulating that same parameter change within software and seeing if the results agree.

³*Analytical* thinking involves the “disassembly” of an idea into its constituent parts, analogous to dissection. *Synthetic* thinking involves the “assembly” of a new idea comprised of multiple concepts, analogous to construction. Both activities are high-level cognitive skills, extremely important for effective problem-solving, necessitating frequent challenge and regular practice to fully develop.

5.1.1 Reading outline and reflections

“Reading maketh a full man; conference a ready man; and writing an exact man” – Francis Bacon

Francis Bacon’s advice is a blueprint for effective education: reading provides the learner with knowledge, writing focuses the learner’s thoughts, and critical dialogue equips the learner to confidently communicate and apply their learning. Independent acquisition and application of knowledge is a powerful skill, well worth the effort to cultivate. To this end, students should read these educational resources closely, journal their own reflections on the reading, and discuss in detail their findings with classmates and instructor(s). You should be able to do all of the following after reading any instructional text:

☑ Briefly **SUMMARIZE THE TEXT** in the form of a journal entry documenting your learning as you progress through the course of study. Share this summary in dialogue with your classmates and instructor. Journaling is an excellent self-test of thorough reading because you cannot clearly express what you have not read or did not comprehend.

☑ Demonstrate **ACTIVE READING STRATEGIES**, including verbalizing your impressions as you read, simplifying long passages to convey the same ideas using fewer words, annotating text and illustrations with your own interpretations, working through mathematical examples shown in the text, cross-referencing passages with relevant illustrations and/or other passages, identifying problem-solving strategies applied by the author, etc. Technical reading is a special case of problem-solving, and so these strategies work precisely because they help solve any problem: paying attention to your own thoughts (metacognition), eliminating unnecessary complexities, identifying what makes sense, paying close attention to details, drawing connections between separated facts, and noting the successful strategies of others.

☑ Identify **IMPORTANT THEMES**, especially **GENERAL LAWS** and **PRINCIPLES**, expounded in the text and express them in the simplest of terms as though you were teaching an intelligent child. This emphasizes connections between related topics and develops your ability to communicate complex ideas to anyone.

☑ Form **YOUR OWN QUESTIONS** based on the reading, and then pose them to your instructor and classmates for their consideration. Anticipate both correct and incorrect answers, the incorrect answer(s) assuming one or more plausible misconceptions. This helps you view the subject from different perspectives to grasp it more fully.

☑ Devise **EXPERIMENTS** to test claims presented in the reading, or to disprove misconceptions. Predict possible outcomes of these experiments, and evaluate their meanings: what result(s) would confirm, and what would constitute disproof? Running mental simulations and evaluating results is essential to scientific and diagnostic reasoning.

☑ Specifically identify any points you found **CONFUSING**. The reason for doing this is to help diagnose misconceptions and overcome barriers to learning.

5.1.2 Foundational concepts

Correct analysis and diagnosis of electric circuits begins with a proper understanding of some basic concepts. The following is a list of some important concepts referenced in this module's full tutorial. Define each of them in your own words, and be prepared to illustrate each of these concepts with a description of a practical example and/or a live demonstration.

Energy

Conservation of Energy

Electromagnetism

Electromagnetic induction

Faraday's Law of electromagnetic induction

Transformer

Primary winding

Secondary winding

Turns ratio

Winding tap

Potential transformer (PT)

Current transformer (CT)

Grounding

Polyphase

Open

Short

Ground loop

Burden

Apparent power

Magnetic flux

Impedance

Remanence

Wire gauge

Class rating

5.1.3 Wattmeter transformers

This wattmeter measures power on one phase of a three-phase power system by sensing both line voltage and line current through instrument transformers:

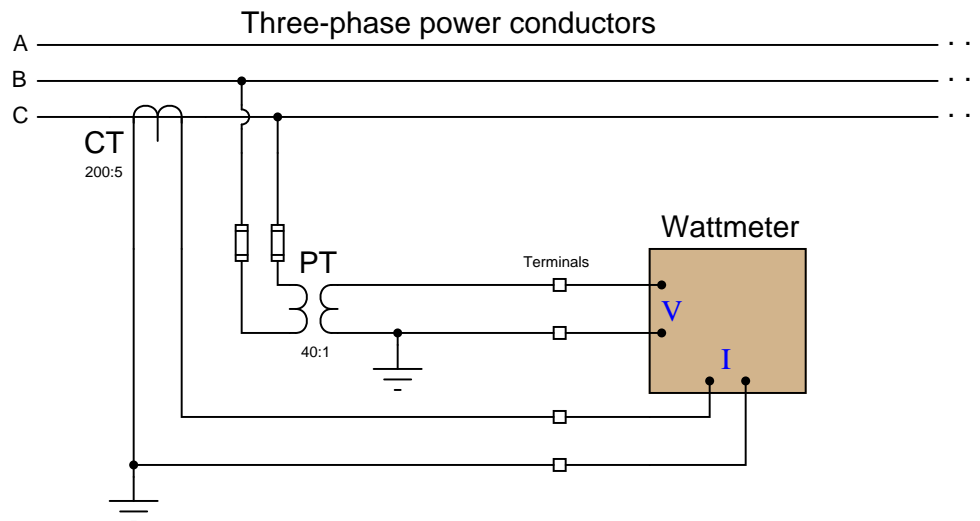

What would you have to do in order to check the calibration of this wattmeter? Specifically, devise a step-by-step procedure that you could give to another technician telling them what they would have to do in order to simulate precise amounts of electrical power to the wattmeter's input, keeping safety in mind as the first priority. Note: you are not allowed to shut power off in the three-phase system to do your test – it must be done “live.”

Challenges

- An important safety rule to apply when working with live circuit is the “one-hand rule.” Explain what this rule is, and how it is applied to a scenario such as this.
- When loosening the screws on a terminal block to remove wires for the PT signal, should you remove the wires from the left-hand side of the terminals (as shown in the diagram) or from the right-hand side, or does this matter at all?
- The task of disconnecting a wattmeter from live instrument transformers presents significant hazard. Devise a way to make this procedure safer, using special “test switches” installed on the signal wires at the time of construction, so that a technician may simply throw the switches’ levers to isolate the wattmeter instead of putting a screwdriver on “live” terminals and removing wires from terminal blocks.
- Suppose the PT’s output signal were 113.6 Volts RMS, and the CT’s output signal were 2.9 Amperes RMS. How much power does this represent flowing through the three-phase lines?

- Why are both instrument transformers' secondary circuits grounded?
- Suppose the potential transformer has a reliability rating of 0.9995 and the current transformer has a reliability rating of 0.9998. Calculate the probability that the wattmeter will receive good information from which to calculate power.

5.1.4 GFCI

A *Ground Fault Current Interruptor*, or *GFCI*, is a special type of AC power receptacle required by the National Electrical Code (NFPA 70) for residential installations near water or any areas that may become wet. The basic idea behind a GFCI is represented in this simplified schematic diagram:

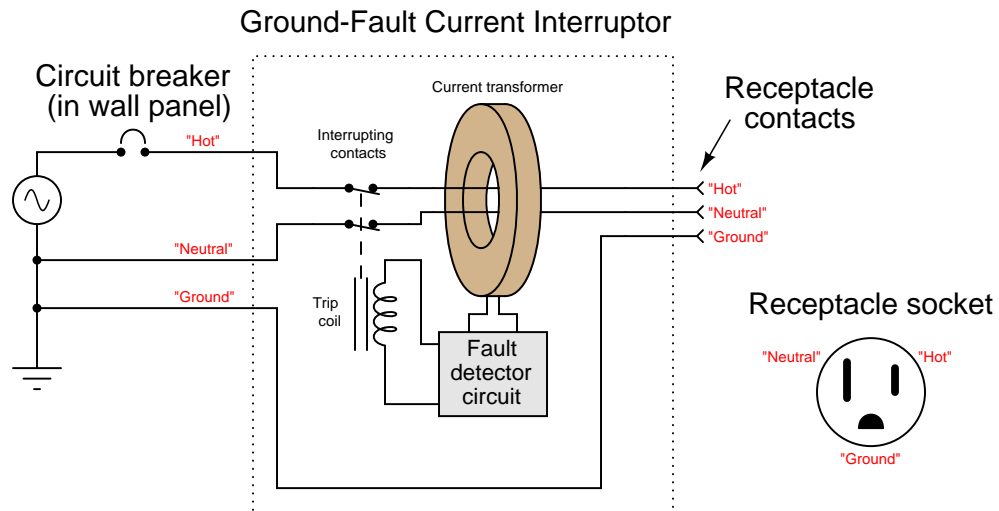

A GFCI receptacle uses a single current transformer (CT) to measure the *difference* in electric current through the “hot” and “neutral” conductors of any electrical appliance plugged into the receptacle. If even a slight difference is detected, the interruptor contacts open, stopping power to the appliance.

Explain how a single CT is able to detect a difference in current between two conductors. Also, explain how a difference in current would ever arise between the “hot” and “neutral” conductors of an appliance. Finally, explain how you could test the proper operation of a GFCI by introducing a real ground fault.

Challenges

- Ground fault current interruption is required by code in residential and commercial installations where the possibility of a wet surface exists. Explain why ground/floor moisture is a factor for consideration here.

5.1.5 PT and CT magnetic flux levels

All transformers regardless of type or application function on the same basic principle: current passing through one coil produces a magnetic field experienced by the other coil(s), inducing voltage in the other coil(s) as predicted by Faraday's Law of Electromagnetic Induction:

$$V = N \frac{d\Phi}{dt}$$

Where,

V = Induced voltage across the coil, in Volts

N = Number of "turns" or "wraps" in the coil

$\frac{d\Phi}{dt}$ = Rate-of-change of magnetic flux, in Webers per second

Voltage is therefore a function of how *quickly* magnetic flux rises or falls in strength within the core of a transformer. Magnetic flux, in turn, is a function of how much voltage has been across the coil and for how long:

$$\Phi = \frac{1}{N} \int_0^T V dt + \Phi_0$$

Where,

Φ = Total magnetic flux accumulated in the core, in Webers

N = Number of "turns" or "wraps" in the coil

V = Induced voltage across the coil, in Volts

T = The amount of time over which magnetic flux accumulates, in seconds

Φ_0 = Original magnetic flux present in the core at time = 0, in Webers

Simply put, the more voltage exists across a coil, the more magnetic flux accumulates within that coil's core. Also, the more *time* that voltage exists across a coil, the more magnetic flux accumulates within the core. In any transformer powered by alternating current (AC), this total amount of flux generally builds to some maximum level, decays to zero, builds to a symmetrical negative (maximum) level, decays back to zero, and then builds to a positive level again.

Compare the amount of magnetic flux you would expect there to be within the iron cores of a PT and of a CT operating under ideal conditions (i.e. PT driving a voltmeter and CT driving an ammeter):

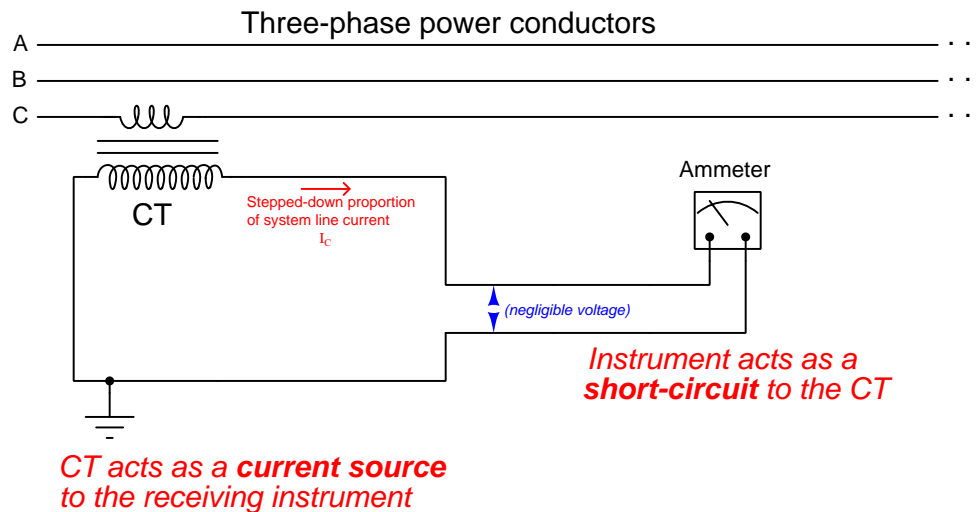
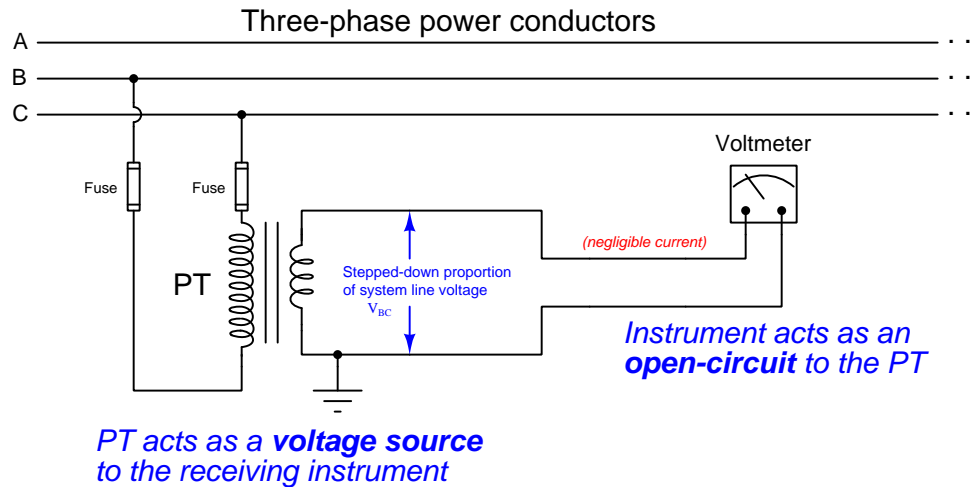

Challenges

- What circuit conditions might prompt a PT's core flux to increase to the point of saturation?
- What circuit conditions might prompt a CT's core flux to increased to the point of saturation?

5.2 Quantitative reasoning

These questions are designed to stimulate your computational thinking. In a Socratic discussion with your instructor, the goal is for these questions to reveal your mathematical approach(es) to problem-solving so that good technique and sound reasoning may be reinforced. Your instructor may also pose additional questions based on those assigned, in order to observe your problem-solving firsthand.

Mental arithmetic and estimations are strongly encouraged for all calculations, because without these abilities you will be unable to readily detect errors caused by calculator misuse (e.g. keystroke errors).

You will note a conspicuous lack of answers given for these quantitative questions. Unlike standard textbooks where answers to every other question are given somewhere toward the back of the book, here in these learning modules students must rely on other means to check their work. My advice is to use circuit simulation software such as SPICE to check the correctness of quantitative answers. Refer to those learning modules within this collection focusing on SPICE to see worked examples which you may use directly as practice problems for your own study, and/or as templates you may modify to run your own analyses and generate your own practice problems.

Completely worked example problems found in the Tutorial may also serve as “test cases⁴” for gaining proficiency in the use of circuit simulation software, and then once that proficiency is gained you will never need to rely⁵ on an answer key!

⁴In other words, set up the circuit simulation software to analyze the same circuit examples found in the Tutorial. If the simulated results match the answers shown in the Tutorial, it confirms the simulation has properly run. If the simulated results disagree with the Tutorial’s answers, something has been set up incorrectly in the simulation software. Using every Tutorial as practice in this way will quickly develop proficiency in the use of circuit simulation software.

⁵This approach is perfectly in keeping with the instructional philosophy of these learning modules: *teaching students to be self-sufficient thinkers*. Answer keys can be useful, but it is even more useful to your long-term success to have a set of tools on hand for checking your own work, because once you have left school and are on your own, there will no longer be “answer keys” available for the problems you will have to solve.

5.2.1 Miscellaneous physical constants

Note: constants shown in **bold** type are *exact*, not approximations. Values inside of parentheses show one standard deviation (σ) of uncertainty in the final digits: for example, the magnetic permeability of free space value given as $1.25663706212(19) \times 10^{-6}$ H/m represents a center value (i.e. the location parameter) of $1.25663706212 \times 10^{-6}$ Henrys per meter with one standard deviation of uncertainty equal to $0.0000000000019 \times 10^{-6}$ Henrys per meter.

Avogadro's number (N_A) = **6.02214076** $\times 10^{23}$ **per mole** (mol⁻¹)

Boltzmann's constant (k) = **1.380649** $\times 10^{-23}$ **Joules per Kelvin** (J/K)

Electronic charge (e) = **1.602176634** $\times 10^{-19}$ **Coulomb** (C)

Faraday constant (F) = **96,485.33212...** $\times 10^4$ **Coulombs per mole** (C/mol)

Magnetic permeability of free space (μ_0) = $1.25663706212(19) \times 10^{-6}$ Henrys per meter (H/m)

Electric permittivity of free space (ϵ_0) = $8.8541878128(13) \times 10^{-12}$ Farads per meter (F/m)

Characteristic impedance of free space (Z_0) = $376.730313668(57)$ Ohms (Ω)

Gravitational constant (G) = $6.67430(15) \times 10^{-11}$ cubic meters per kilogram-seconds squared (m³/kg-s²)

Molar gas constant (R) = **8.314462618...** **Joules per mole-Kelvin** (J/mol-K) = 0.08205746(14) liters-atmospheres per mole-Kelvin

Planck constant (h) = **6.62607015** $\times 10^{-34}$ **joule-seconds** (J-s)

Stefan-Boltzmann constant (σ) = **5.670374419...** $\times 10^{-8}$ **Watts per square meter-Kelvin⁴** (W/m²·K⁴)

Speed of light in a vacuum (c) = **299,792,458 meters per second** (m/s) = 186282.4 miles per second (mi/s)

Note: All constants taken from NIST data "Fundamental Physical Constants – Complete Listing", from <http://physics.nist.gov/constants>, National Institute of Standards and Technology (NIST), 2018 CODATA Adjustment.

5.2.2 Introduction to spreadsheets

A powerful computational tool you are encouraged to use in your work is a *spreadsheet*. Available on most personal computers (e.g. Microsoft Excel), *spreadsheet* software performs numerical calculations based on number values and formulae entered into cells of a grid. This grid is typically arranged as lettered columns and numbered rows, with each cell of the grid identified by its column/row coordinates (e.g. cell B3, cell A8). Each cell may contain a string of text, a number value, or a mathematical formula. The spreadsheet automatically updates the results of all mathematical formulae whenever the entered number values are changed. This means it is possible to set up a spreadsheet to perform a series of calculations on entered data, and those calculations will be re-done by the computer any time the data points are edited in any way.

For example, the following spreadsheet calculates average speed based on entered values of distance traveled and time elapsed:

	A	B	C	D
1	Distance traveled	46.9	Kilometers	
2	Time elapsed	1.18	Hours	
3	Average speed	= B1 / B2	km/h	
4				
5				

Text labels contained in cells A1 through A3 and cells C1 through C3 exist solely for readability and are not involved in any calculations. Cell B1 contains a sample distance value while cell B2 contains a sample time value. The formula for computing speed is contained in cell B3. Note how this formula begins with an “equals” symbol (=), references the values for distance and speed by lettered column and numbered row coordinates (B1 and B2), and uses a forward slash symbol for division (/). The coordinates B1 and B2 function as *variables*⁶ would in an algebraic formula.

When this spreadsheet is executed, the numerical value 39.74576 will appear in cell B3 rather than the formula = B1 / B2, because 39.74576 is the computed speed value given 46.9 kilometers traveled over a period of 1.18 hours. If a different numerical value for distance is entered into cell B1 or a different value for time is entered into cell B2, cell B3’s value will automatically update. All you need to do is set up the given values and any formulae into the spreadsheet, and the computer will do all the calculations for you.

Cell B3 may be referenced by other formulae in the spreadsheet if desired, since it is a variable just like the given values contained in B1 and B2. This means it is possible to set up an entire chain of calculations, one dependent on the result of another, in order to arrive at a final value. The arrangement of the given data and formulae need not follow any pattern on the grid, which means you may place them anywhere.

⁶Spreadsheets may also provide means to attach text labels to cells for use as variable names (Microsoft Excel simply calls these labels “names”), but for simple spreadsheets such as those shown here it’s usually easier just to use the standard coordinate naming for each cell.

Common⁷ arithmetic operations available for your use in a spreadsheet include the following:

- Addition (+)
- Subtraction (-)
- Multiplication (*)
- Division (/)
- Powers (^)
- Square roots (sqrt())
- Logarithms (ln() , log10())

Parentheses may be used to ensure⁸ proper order of operations within a complex formula. Consider this example of a spreadsheet implementing the *quadratic formula*, used to solve for roots of a polynomial expression in the form of $ax^2 + bx + c$:

$$x = \frac{-b \pm \sqrt{b^2 - 4ac}}{2a}$$

	A	B
1	x_1	= (-B4 + sqrt((B4^2) - (4*B3*B5))) / (2*B3)
2	x_2	= (-B4 - sqrt((B4^2) - (4*B3*B5))) / (2*B3)
3	a =	9
4	b =	5
5	c =	-2

This example is configured to compute roots⁹ of the polynomial $9x^2 + 5x - 2$ because the values of 9, 5, and -2 have been inserted into cells B3, B4, and B5, respectively. Once this spreadsheet has been built, though, it may be used to calculate the roots of *any* second-degree polynomial expression simply by entering the new a , b , and c coefficients into cells B3 through B5. The numerical values appearing in cells B1 and B2 will be automatically updated by the computer immediately following any changes made to the coefficients.

⁷Modern spreadsheet software offers a bewildering array of mathematical functions you may use in your computations. I recommend you consult the documentation for your particular spreadsheet for information on operations other than those listed here.

⁸Spreadsheet programs, like text-based programming languages, are designed to follow standard order of operations by default. However, my personal preference is to use parentheses even where strictly unnecessary just to make it clear to any other person viewing the formula what the intended order of operations is.

⁹Reviewing some algebra here, a *root* is a value for x that yields an overall value of zero for the polynomial. For this polynomial ($9x^2 + 5x - 2$) the two roots happen to be $x = 0.269381$ and $x = -0.82494$, with these values displayed in cells B1 and B2, respectively upon execution of the spreadsheet.

Alternatively, one could break up the long quadratic formula into smaller pieces like this:

$$y = \sqrt{b^2 - 4ac} \quad z = 2a$$

$$x = \frac{-b \pm y}{z}$$

	A	B	C
1	x_1	= (-B4 + C1) / C2	= sqrt((B4^2) - (4*B3*B5))
2	x_2	= (-B4 - C1) / C2	= 2*B3
3	a =	9	
4	b =	5	
5	c =	-2	

Note how the square-root term (y) is calculated in cell C1, and the denominator term (z) in cell C2. This makes the two final formulae (in cells B1 and B2) simpler to interpret. The positioning of all these cells on the grid is completely arbitrary¹⁰ – all that matters is that they properly reference each other in the formulae.

Spreadsheets are particularly useful for situations where the same set of calculations representing a circuit or other system must be repeated for different initial conditions. The power of a spreadsheet is that it automates what would otherwise be a tedious set of calculations. One specific application of this is to simulate the effects of various components within a circuit failing with abnormal values (e.g. a shorted resistor simulated by making its value nearly zero; an open resistor simulated by making its value extremely large). Another application is analyzing the behavior of a circuit design given new components that are out of specification, and/or aging components experiencing drift over time.

¹⁰My personal preference is to locate all the “given” data in the upper-left cells of the spreadsheet grid (each data point flanked by a sensible name in the cell to the left and units of measurement in the cell to the right as illustrated in the first distance/time spreadsheet example), sometimes coloring them in order to clearly distinguish which cells contain entered data versus which cells contain computed results from formulae. I like to place all formulae in cells below the given data, and try to arrange them in logical order so that anyone examining my spreadsheet will be able to figure out *how* I constructed a solution. This is a general principle I believe all computer programmers should follow: *document and arrange your code to make it easy for other people to learn from it.*

5.2.3 Multi-ratio CT wiring

Sketch wire connections to complete wiring between this SEL-387L differential current relay and a set of three line CTs. Note that only a few of the available terminals on the SEL-387L relay are shown, and that the line CTs are *multi-ratio current transformers* with different “taps” to choose from:

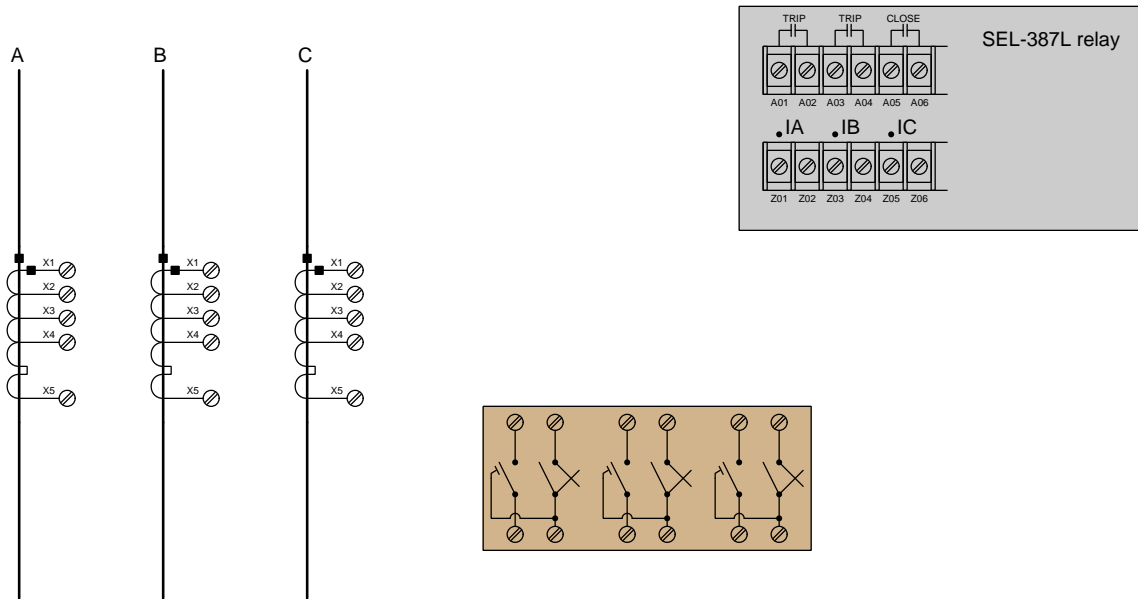

Assume we wish to have the CT ratios be 1200:5 each. The number of CT secondary winding turns between adjacent terminals are as follows:

Terminals	Turns
X1 – X2	80
X2 – X3	160
X3 – X4	60
X4 – X5	100

Challenges

- Since we only need two terminals on the secondary of each CT, should the other (unused) terminals be shorted together for safety? Why or why not?

5.2.4 CT circuit voltages

Suppose an 800:5 current transformer is connected to a protective relay presenting a purely resistive burden of 0.7 Ohms. The wire used to connect the CT to the relay is 12 gauge copper, 1500 feet total circuit length (i.e. 750 feet cable length for a 2-conductor cable).

From this information, determine both the voltage dropped across the relay's terminals at a fault current value of 4.5 kA (power line current), as well as the voltage dropped across the CT's terminals at that same current.

$$V_{relay} =$$

$$V_{CT-terminals} =$$

Challenges

- The Fluke brand 80-series digital multimeters are advertised as exhibiting 1.8 mV/mA of burden when measuring current in the low range (up to 400 mA maximum), and 0.03 V/A burden when measuring current in the high range (up to 10 Amperes maximum). How do these specifications compare to the burden of the protective relay in this question's scenario? Would a Fluke 80-series DMM present a lesser or greater burden to the CT than the specified relay? Would you recommend using a digital multimeter to interpret current from the CT in this application?

5.2.5 Motor line currents

Calculate the current measured by each ammeter assuming the motor's power consumption is 95 kW with a perfect power factor (1), the phase rotation is CBA, and $V_A = 277\angle -20^\circ$. Be sure to express each current value in polar form:

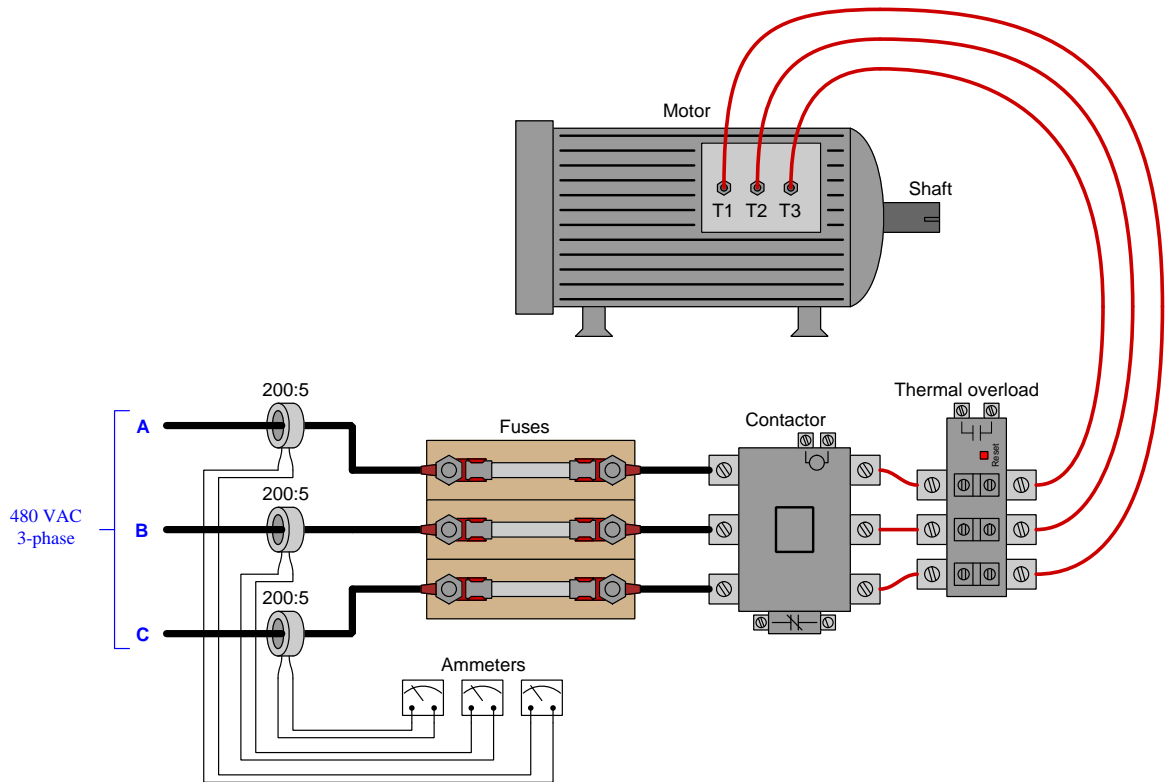

Ammeter "A" current =

Ammeter "B" current =

Ammeter "C" current =

Challenges

- What advantage is there in using CTs to measure the motor's current this way, rather than line-connected ammeters?
- Incorporate proper Earth grounding into the CT circuits shown.

5.2.6 Transformer-isolated voltage calculations

Calculate the V_G and V_H in this circuit, expressing both answers in polar form. Assume a balanced three-phase system with UVW phase rotation, where $V_U = 277$ Volts $\angle -15^\circ$ and $I_W = 83$ Amperes $\angle 100^\circ$:

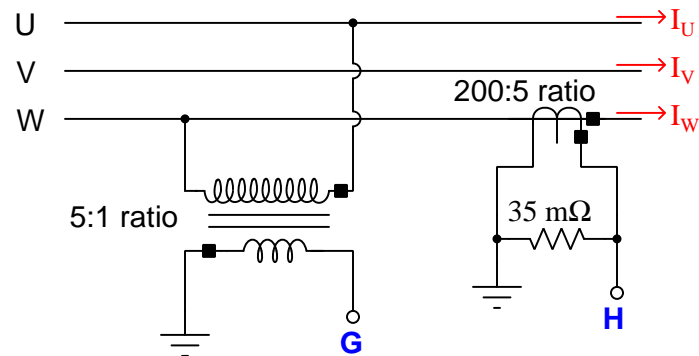

$$V_G =$$

$$V_H =$$

Challenges

- Annotate this circuit with voltage polarity marks (+, -) and current arrows.

5.2.7 Paralleled CTs

Suppose a pair of current transformers with 600:5 ratios are parallel-connected to feed their output signals to a protective relay as shown in this schematic diagram:

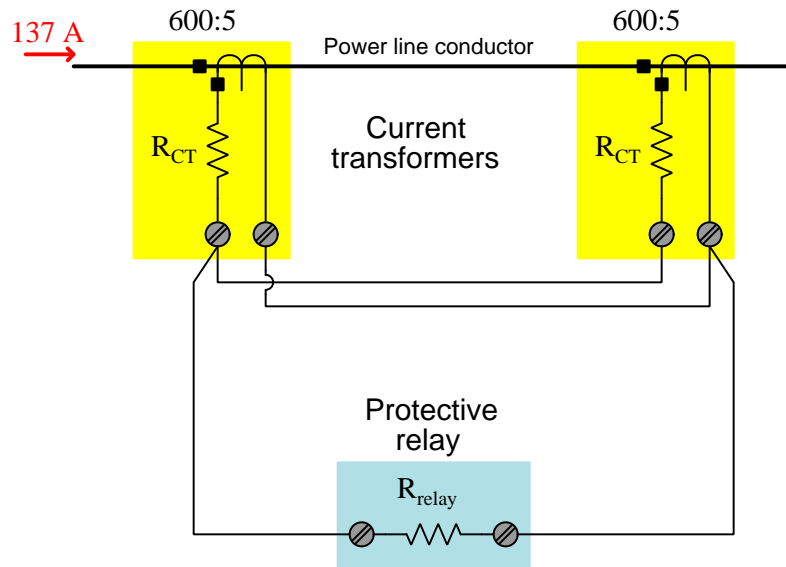

- $R_{CT} = 0.5 \Omega$ (this is the internal resistance of each CT's secondary winding)
- $R_{relay} = 1.8 \Omega$

Calculate the following voltage drops in this current transformer circuit, from the given information:

- $V_{relay} =$
- Voltage output at each CT's terminals =
- Voltage generated by each CT's secondary winding (before any R_{CT} losses) =

Challenges

- Why might one wish to connect two CTs in parallel with each other?

5.2.8 Series-connected CTs

Calculate all currents and voltages in this current transformer (CT) circuit:

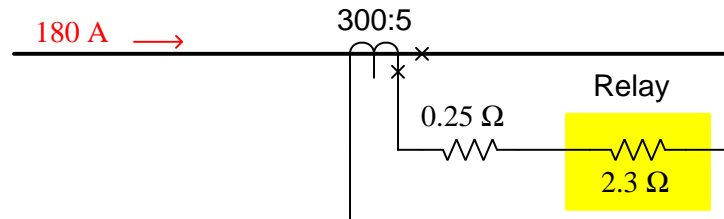

Now, calculate all currents and voltages in this current transformer circuit, with two identical CTs connected in series:

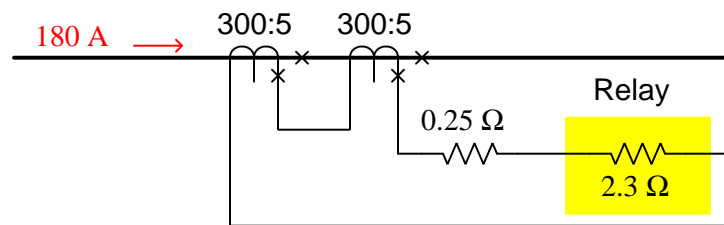

Finally, sketch the direction of current through each CT assuming the direction shown by the 180 Ampere arrow at one particular instant in time.

Challenges

- Why might one wish to connect two CTs in series with each other?

5.2.9 Polarizing coil current

Every AC meter connected to an instrument transformer presents a *burden* to that transformer, whether it be a PT or a CT. The greater a relay's burden, the more power is demanded from the instrument transformer and the less accurate the system will tend to be. For this reason, burden is a very important parameter to consider when wiring a protective relay system.

The datasheet for a General Electric model CEB52 “distance” protective relay (ANSI/IEEE code 21) shows the burden for its “polarizing coil” PT input to be $1540 - j162$ ohms. Calculate the current through this coil when the PT's output signal is 103 Volts $\angle -6^\circ$.

Challenges

- What would the *ideal* burden be for this particular relay, so as to present the lightest load possible to the PT?

5.3 Diagnostic reasoning

These questions are designed to stimulate your deductive and inductive thinking, where you must apply general principles to specific scenarios (deductive) and also derive conclusions about the failed circuit from specific details (inductive). In a Socratic discussion with your instructor, the goal is for these questions to reinforce your recall and use of general circuit principles and also challenge your ability to integrate multiple symptoms into a sensible explanation of what's wrong in a circuit. Your instructor may also pose additional questions based on those assigned, in order to further challenge and sharpen your diagnostic abilities.

As always, your goal is to fully *explain* your analysis of each problem. Simply obtaining a correct answer is not good enough – you must also demonstrate sound reasoning in order to successfully complete the assignment. Your instructor's responsibility is to probe and challenge your understanding of the relevant principles and analytical processes in order to ensure you have a strong foundation upon which to build further understanding.

You will note a conspicuous lack of answers given for these diagnostic questions. Unlike standard textbooks where answers to every other question are given somewhere toward the back of the book, here in these learning modules students must rely on other means to check their work. The best way by far is to debate the answers with fellow students and also with the instructor during the Socratic dialogue sessions intended to be used with these learning modules. Reasoning through challenging questions with other people is an excellent tool for developing strong reasoning skills.

Another means of checking your diagnostic answers, where applicable, is to use circuit simulation software to explore the effects of faults placed in circuits. For example, if one of these diagnostic questions requires that you predict the effect of an open or a short in a circuit, you may check the validity of your work by simulating that same fault (substituting a very high resistance in place of that component for an open, and substituting a very low resistance for a short) within software and seeing if the results agree.

5.3.1 Damaged data acquisition system

A technician connects a DAQ (Data Acquisition) module to one phase of a 480 VAC three-phase electric motor in order to measure and record that motor's voltage and current simultaneously on a laptop computer. The DAQ functions as a high-speed analog-to-digital converter unit with eight voltage-sensing input channels (AI0 through AI7), allowing the computer to display and record a time-based graph of motor voltage and motor current over time. In essence, this DAQ acts as a digital voltmeter with eight measurement channels, each of those channels having its own "red" test lead while all channels share a common "black" test lead (the two redundant COM terminals).

Knowing that the phase-to-phase voltage of approximately 480 Volts and the line current of approximately 25 Amperes will be far too great for the DAQ to directly measure, the technician uses *instrument transformers* (a "PT" potential transformer and a "CT" current transformer) to step these voltages and currents to more reasonable values:

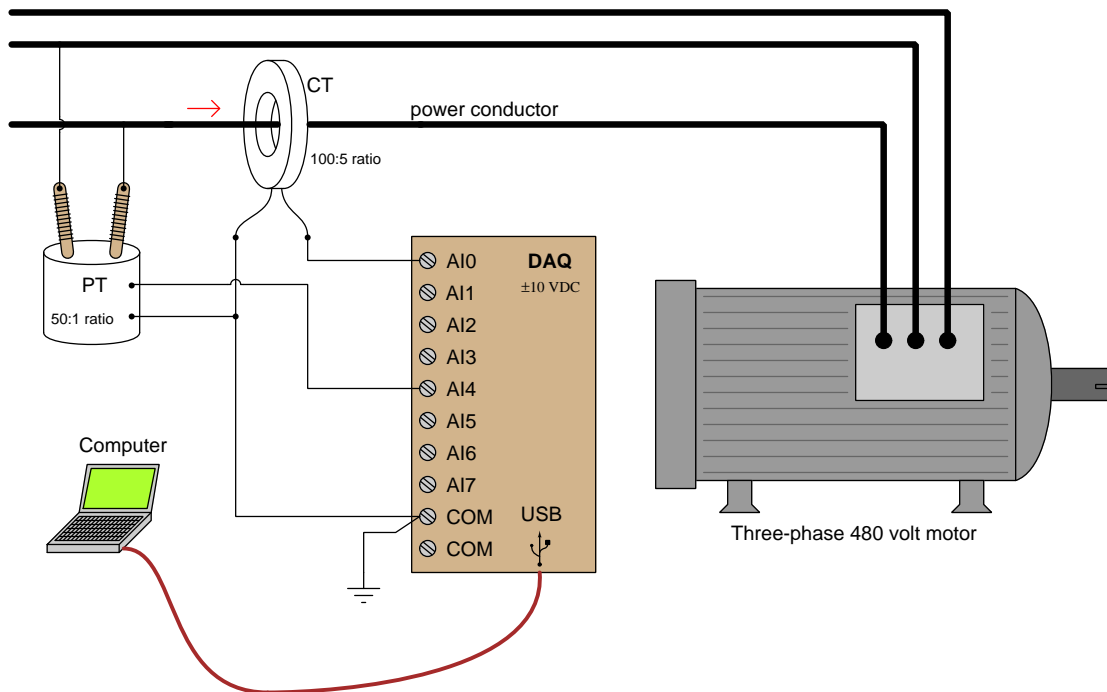

Unfortunately, as soon as the motor is energized, the DAQ disappears in a bright flash of light and cloud of smoke. The destruction also propagated to the PC the DAQ was connected to (through the USB cable)! What went wrong, and how should the technician correct his mistake? Assume we must use the same model of DAQ unit having the same ± 10 Volt input limits.

Challenges

- Identify some practical tests the technician could have done prior to connecting the instrument transformers to the DAQ unit, to ensure that DAQ would not be damaged.

Appendix A

Problem-Solving Strategies

The ability to solve complex problems is arguably one of the most valuable skills one can possess, and this skill is particularly important in any science-based discipline.

- Study principles, not procedures. Don't be satisfied with merely knowing how to compute solutions – learn *why* those solutions work.
- Identify what it is you need to solve, identify all relevant data, identify all units of measurement, identify any general principles or formulae linking the given information to the solution, and then identify any “missing pieces” to a solution. Annotate all diagrams with this data.
- Sketch a diagram to help visualize the problem. When building a real system, always devise a plan for that system and analyze its function *before* constructing it.
- Follow the units of measurement and meaning of every calculation. If you are ever performing mathematical calculations as part of a problem-solving procedure, and you find yourself unable to apply each and every intermediate result to some aspect of the problem, it means you don't understand what you are doing. Properly done, every mathematical result should have practical meaning for the problem, and not just be an abstract number. You should be able to identify the proper units of measurement for each and every calculated result, and show where that result fits into the problem.
- Perform “thought experiments” to explore the effects of different conditions for theoretical problems. When troubleshooting real systems, perform *diagnostic tests* rather than visually inspecting for faults, the best diagnostic test being the one giving you the most information about the nature and/or location of the fault with the fewest steps.
- Simplify the problem until the solution becomes obvious, and then use that obvious case as a model to follow in solving the more complex version of the problem.
- Check for exceptions to see if your solution is incorrect or incomplete. A good solution will work for *all* known conditions and criteria. A good example of this is the process of testing scientific hypotheses: the task of a scientist is not to find support for a new idea, but rather to *challenge* that new idea to see if it holds up under a battery of tests. The philosophical

principle of *reductio ad absurdum* (i.e. disproving a general idea by finding a specific case where it fails) is useful here.

- Work “backward” from a hypothetical solution to a new set of given conditions.
- Add quantities to problems that are qualitative in nature, because sometimes a little math helps illuminate the scenario.
- Sketch graphs illustrating how variables relate to each other. These may be quantitative (i.e. with realistic number values) or qualitative (i.e. simply showing increases and decreases).
- Treat quantitative problems as qualitative in order to discern the relative magnitudes and/or directions of change of the relevant variables. For example, try determining what happens if a certain variable were to increase or decrease before attempting to precisely calculate quantities: how will each of the dependent variables respond, by increasing, decreasing, or remaining the same as before?
- Consider limiting cases. This works especially well for qualitative problems where you need to determine which direction a variable will change. Take the given condition and magnify that condition to an extreme degree as a way of simplifying the direction of the system’s response.
- Check your work. This means regularly testing your conclusions to see if they make sense. This does *not* mean repeating the same steps originally used to obtain the conclusion(s), but rather to use some other means to check validity. Simply repeating procedures often leads to *repeating the same errors* if any were made, which is why alternative paths are better.

Appendix B

Instructional philosophy

“The unexamined circuit is not worth energizing” – Socrates (if he had taught electricity)

These learning modules, although useful for self-study, were designed to be used in a formal learning environment where a subject-matter expert challenges students to digest the content and exercise their critical thinking abilities in the answering of questions and in the construction and testing of working circuits.

The following principles inform the instructional and assessment philosophies embodied in these learning modules:

- The first goal of education is to enhance clear and independent thought, in order that every student reach their fullest potential in a highly complex and inter-dependent world. Robust reasoning is *always* more important than particulars of any subject matter, because its application is universal.
- Literacy is fundamental to independent learning and thought because text continues to be the most efficient way to communicate complex ideas over space and time. Those who cannot read with ease are limited in their ability to acquire knowledge and perspective.
- Articulate communication is fundamental to work that is complex and interdisciplinary.
- Faulty assumptions and poor reasoning are best corrected through challenge, not presentation. The rhetorical technique of *reductio ad absurdum* (disproving an assertion by exposing an absurdity) works well to discipline student’s minds, not only to correct the problem at hand but also to learn how to detect and correct future errors.
- Important principles should be repeatedly explored and widely applied throughout a course of study, not only to reinforce their importance and help ensure their mastery, but also to showcase the interconnectedness and utility of knowledge.

These learning modules were expressly designed to be used in an “inverted” teaching environment¹ where students first read the introductory and tutorial chapters on their own, then individually attempt to answer the questions and construct working circuits according to the experiment and project guidelines. The instructor never lectures, but instead meets regularly with each individual student to review their progress, answer questions, identify misconceptions, and challenge the student to new depths of understanding through further questioning. Regular meetings between instructor and student should resemble a Socratic² dialogue, where questions serve as scalpels to dissect topics and expose assumptions. The student passes each module only after consistently demonstrating their ability to logically analyze and correctly apply all major concepts in each question or project/experiment. The instructor must be vigilant in probing each student’s understanding to ensure they are truly *reasoning* and not just *memorizing*. This is why “Challenge” points appear throughout, as prompts for students to think deeper about topics and as starting points for instructor queries. Sometimes these challenge points require additional knowledge that hasn’t been covered in the series to answer in full. This is okay, as the major purpose of the Challenges is to stimulate analysis and synthesis on the part of each student.

The instructor must possess enough mastery of the subject matter and awareness of students’ reasoning to generate their own follow-up questions to practically any student response. Even completely correct answers given by the student should be challenged by the instructor for the purpose of having students practice articulating their thoughts and defending their reasoning. Conceptual errors committed by the student should be exposed and corrected not by direct instruction, but rather by reducing the errors to an absurdity³ through well-chosen questions and thought experiments posed by the instructor. Becoming proficient at this style of instruction requires time and dedication, but the positive effects on critical thinking for both student and instructor are spectacular.

An inspection of these learning modules reveals certain unique characteristics. One of these is a bias toward thorough explanations in the tutorial chapters. Without a live instructor to explain concepts and applications to students, the text itself must fulfill this role. This philosophy results in lengthier explanations than what you might typically find in a textbook, each step of the reasoning process fully explained, including footnotes addressing common questions and concerns students raise while learning these concepts. Each tutorial seeks to not only explain each major concept in sufficient detail, but also to explain the logic of each concept and how each may be developed

¹In a traditional teaching environment, students first encounter new information via *lecture* from an expert, and then independently apply that information via *homework*. In an “inverted” course of study, students first encounter new information via *homework*, and then independently apply that information under the scrutiny of an expert. The expert’s role in lecture is to simply *explain*, but the expert’s role in an inverted session is to *challenge, critique*, and if necessary *explain* where gaps in understanding still exist.

²Socrates is a figure in ancient Greek philosophy famous for his unflinching style of questioning. Although he authored no texts, he appears as a character in Plato’s many writings. The essence of Socratic philosophy is to leave no question unexamined and no point of view unchallenged. While purists may argue a topic such as electric circuits is too narrow for a true Socratic-style dialogue, I would argue that the essential thought processes involved with scientific reasoning on *any* topic are not far removed from the Socratic ideal, and that students of electricity and electronics would do very well to challenge assumptions, pose thought experiments, identify fallacies, and otherwise employ the arsenal of critical thinking skills modeled by Socrates.

³This rhetorical technique is known by the Latin phrase *reductio ad absurdum*. The concept is to expose errors by counter-example, since only one solid counter-example is necessary to disprove a universal claim. As an example of this, consider the common misconception among beginning students of electricity that voltage cannot exist without current. One way to apply *reductio ad absurdum* to this statement is to ask how much current passes through a fully-charged battery connected to nothing (i.e. a clear example of voltage existing without current).

from “first principles”. Again, this reflects the goal of developing clear and independent thought in students’ minds, by showing how clear and logical thought was used to forge each concept. Students benefit from witnessing a model of clear thinking in action, and these tutorials strive to be just that.

Another characteristic of these learning modules is a lack of step-by-step instructions in the Project and Experiment chapters. Unlike many modern workbooks and laboratory guides where step-by-step instructions are prescribed for each experiment, these modules take the approach that students must learn to closely read the tutorials and apply their own reasoning to identify the appropriate experimental steps. Sometimes these steps are plainly declared in the text, just not as a set of enumerated points. At other times certain steps are implied, an example being assumed competence in test equipment use where the student should not need to be told *again* how to use their multimeter because that was thoroughly explained in previous lessons. In some circumstances no steps are given at all, leaving the entire procedure up to the student.

This lack of prescription is not a flaw, but rather a feature. Close reading and clear thinking are foundational principles of this learning series, and in keeping with this philosophy all activities are designed to *require* those behaviors. Some students may find the lack of prescription frustrating, because it demands more from them than what their previous educational experiences required. This frustration should be interpreted as an unfamiliarity with autonomous thinking, a problem which must be corrected if the student is ever to become a self-directed learner and effective problem-solver. Ultimately, the need for students to read closely and think clearly is more important both in the near-term and far-term than any specific facet of the subject matter at hand. If a student takes longer than expected to complete a module because they are forced to outline, digest, and reason on their own, so be it. The future gains enjoyed by developing this mental discipline will be well worth the additional effort and delay.

Another feature of these learning modules is that they do not treat topics in isolation. Rather, important concepts are introduced early in the series, and appear repeatedly as stepping-stones toward other concepts in subsequent modules. This helps to avoid the “compartmentalization” of knowledge, demonstrating the inter-connectedness of concepts and simultaneously reinforcing them. Each module is fairly complete in itself, reserving the beginning of its tutorial to a review of foundational concepts.

This methodology of assigning text-based modules to students for digestion and then using Socratic dialogue to assess progress and hone students’ thinking was developed over a period of several years by the author with his Electronics and Instrumentation students at the two-year college level. While decidedly unconventional and sometimes even unsettling for students accustomed to a more passive lecture environment, this instructional philosophy has proven its ability to convey conceptual mastery, foster careful analysis, and enhance employability so much better than lecture that the author refuses to ever teach by lecture again.

Problems which often go undiagnosed in a lecture environment are laid bare in this “inverted” format where students must articulate and logically defend their reasoning. This, too, may be unsettling for students accustomed to lecture sessions where the instructor cannot tell for sure who comprehends and who does not, and this vulnerability necessitates sensitivity on the part of the “inverted” session instructor in order that students never feel discouraged by having their errors exposed. *Everyone* makes mistakes from time to time, and learning is a lifelong process! Part of the instructor’s job is to build a culture of learning among the students where errors are not seen as shameful, but rather as opportunities for progress.

To this end, instructors managing courses based on these modules should adhere to the following principles:

- Student questions are always welcome and demand thorough, honest answers. The only type of question an instructor should refuse to answer is one the student should be able to easily answer on their own. Remember, *the fundamental goal of education is for each student to learn to think clearly and independently*. This requires hard work on the part of the student, which no instructor should ever circumvent. Anything done to bypass the student's responsibility to do that hard work ultimately limits that student's potential and thereby does real harm.
- It is not only permissible, but encouraged, to answer a student's question by asking questions in return, these follow-up questions designed to guide the student to reach a correct answer through their own reasoning.
- All student answers demand to be challenged by the instructor and/or by other students. This includes both correct and incorrect answers – the goal is to practice the articulation and defense of one's own reasoning.
- No reading assignment is deemed complete unless and until the student demonstrates their ability to accurately summarize the major points in their own terms. Recitation of the original text is unacceptable. This is why every module contains an "Outline and reflections" question as well as a "Foundational concepts" question in the Conceptual reasoning section, to prompt reflective reading.
- No assigned question is deemed answered unless and until the student demonstrates their ability to consistently and correctly apply the concepts to *variations* of that question. This is why module questions typically contain multiple "Challenges" suggesting different applications of the concept(s) as well as variations on the same theme(s). Instructors are encouraged to devise as many of their own "Challenges" as they are able, in order to have a multitude of ways ready to probe students' understanding.
- No assigned experiment or project is deemed complete unless and until the student demonstrates the task in action. If this cannot be done "live" before the instructor, video-recordings showing the demonstration are acceptable. All relevant safety precautions must be followed, all test equipment must be used correctly, and the student must be able to properly explain all results. The student must also successfully answer all Challenges presented by the instructor for that experiment or project.

Students learning from these modules would do well to abide by the following principles:

- No text should be considered fully and adequately read unless and until you can express every idea *in your own words, using your own examples*.
- You should always articulate your thoughts as you read the text, noting points of agreement, confusion, and epiphanies. Feel free to print the text on paper and then write your notes in the margins. Alternatively, keep a journal for your own reflections as you read. This is truly a helpful tool when digesting complicated concepts.
- Never take the easy path of highlighting or underlining important text. Instead, *summarize* and/or *comment* on the text using your own words. This actively engages your mind, allowing you to more clearly perceive points of confusion or misunderstanding on your own.
- A very helpful strategy when learning new concepts is to place yourself in the role of a teacher, if only as a mental exercise. Either explain what you have recently learned to someone else, or at least *imagine* yourself explaining what you have learned to someone else. The simple act of having to articulate new knowledge and skill forces you to take on a different perspective, and will help reveal weaknesses in your understanding.
- Perform each and every mathematical calculation and thought experiment shown in the text on your own, referring back to the text to see that your results agree. This may seem trivial and unnecessary, but it is critically important to ensuring you actually understand what is presented, especially when the concepts at hand are complicated and easy to misunderstand. Apply this same strategy to become proficient in the use of *circuit simulation software*, checking to see if your simulated results agree with the results shown in the text.
- Above all, recognize that learning is hard work, and that a certain level of frustration is unavoidable. There are times when you will struggle to grasp some of these concepts, and that struggle is a natural thing. Take heart that it will yield with persistent and varied⁴ effort, and never give up!

Students interested in using these modules for self-study will also find them beneficial, although the onus of responsibility for thoroughly reading and answering questions will of course lie with that individual alone. If a qualified instructor is not available to challenge students, a workable alternative is for students to form study groups where they challenge⁵ one another.

To high standards of education,

Tony R. Kuphaldt

⁴As the old saying goes, “Insanity is trying the same thing over and over again, expecting different results.” If you find yourself stumped by something in the text, you should attempt a different approach. Alter the thought experiment, change the mathematical parameters, do whatever you can to see the problem in a slightly different light, and then the solution will often present itself more readily.

⁵Avoid the temptation to simply share answers with study partners, as this is really counter-productive to learning. Always bear in mind that the answer to any question is far less important in the long run than the method(s) used to obtain that answer. The goal of education is to empower one’s life through the improvement of clear and independent thought, literacy, expression, and various practical skills.

Appendix C

Tools used

I am indebted to the developers of many open-source software applications in the creation of these learning modules. The following is a list of these applications with some commentary on each.

You will notice a theme common to many of these applications: a bias toward *code*. Although I am by no means an expert programmer in any computer language, I understand and appreciate the flexibility offered by code-based applications where the user (you) enters commands into a plain ASCII text file, which the software then reads and processes to create the final output. Code-based computer applications are by their very nature *extensible*, while WYSIWYG (What You See Is What You Get) applications are generally limited to whatever user interface the developer makes for you.

The GNU/Linux computer operating system

There is so much to be said about Linus Torvalds' `Linux` and Richard Stallman's `GNU` project. First, to credit just these two individuals is to fail to do justice to the *mob* of passionate volunteers who contributed to make this amazing software a reality. I first learned of `Linux` back in 1996, and have been using this operating system on my personal computers almost exclusively since then. It is *free*, it is completely *configurable*, and it permits the continued use of highly efficient `Unix` applications and scripting languages (e.g. shell scripts, Makefiles, `sed`, `awk`) developed over many decades. `Linux` not only provided me with a powerful computing platform, but its open design served to inspire my life's work of creating open-source educational resources.

Bram Moolenaar's Vim text editor

Writing code for any code-based computer application requires a *text editor*, which may be thought of as a word processor strictly limited to outputting plain-ASCII text files. Many good text editors exist, and one's choice of text editor seems to be a deeply personal matter within the programming world. I prefer `Vim` because it operates very similarly to `vi` which is ubiquitous on `Unix/Linux` operating systems, and because it may be entirely operated via keyboard (i.e. no mouse required) which makes it fast to use.

Donald Knuth's \TeX typesetting system

Developed in the late 1970's and early 1980's by computer scientist extraordinaire Donald Knuth to typeset his multi-volume magnum opus *The Art of Computer Programming*, this software allows the production of formatted text for screen-viewing or paper printing, all by writing plain-text code to describe how the formatted text is supposed to appear. \TeX is not just a markup language for documents, but it is also a Turing-complete programming language in and of itself, allowing useful algorithms to be created to control the production of documents. Simply put, *\TeX is a programmer's approach to word processing*. Since \TeX is controlled by code written in a plain-text file, this means anyone may read that plain-text file to see exactly how the document was created. This openness afforded by the code-based nature of \TeX makes it relatively easy to learn how other people have created their own \TeX documents. By contrast, examining a beautiful document created in a conventional WYSIWYG word processor such as Microsoft **Word** suggests nothing to the reader about *how* that document was created, or what the user might do to create something similar. As Mr. Knuth himself once quipped, conventional word processing applications should be called WYSIAYG (What You See Is *All* You Get).

Leslie Lamport's \LaTeX extensions to \TeX

Like all true programming languages, \TeX is inherently extensible. So, years after the release of \TeX to the public, Leslie Lamport decided to create a massive extension allowing easier compilation of book-length documents. The result was \LaTeX , which is the markup language used to create all ModEL module documents. You could say that \TeX is to \LaTeX as **C** is to **C++**. This means it is permissible to use any and all \TeX commands within \LaTeX source code, and it all still works. Some of the features offered by \LaTeX that would be challenging to implement in \TeX include automatic index and table-of-content creation.

Tim Edwards' **Xcircuit** drafting program

This wonderful program is what I use to create all the schematic diagrams and illustrations (but not photographic images or mathematical plots) throughout the ModEL project. It natively outputs PostScript format which is a true vector graphic format (this is why the images do not pixellate when you zoom in for a closer view), and it is so simple to use that I have never had to read the manual! Object libraries are easy to create for **Xcircuit**, being plain-text files using PostScript programming conventions. Over the years I have collected a large set of object libraries useful for drawing electrical and electronic schematics, pictorial diagrams, and other technical illustrations.

Gimp graphic image manipulation program

Essentially an open-source clone of Adobe's **PhotoShop**, I use **Gimp** to resize, crop, and convert file formats for all of the photographic images appearing in the **Model** modules. Although **Gimp** does offer its own scripting language (called **Script-Fu**), I have never had occasion to use it. Thus, my utilization of **Gimp** to merely crop, resize, and convert graphic images is akin to using a sword to slice bread.

SPICE circuit simulation program

SPICE is to circuit analysis as **T_EX** is to document creation: it is a form of markup language designed to describe a certain object to be processed in plain-ASCII text. When the plain-text "source file" is compiled by the software, it outputs the final result. More modern circuit analysis tools certainly exist, but I prefer **SPICE** for the following reasons: it is *free*, it is *fast*, it is *reliable*, and it is a fantastic tool for *teaching* students of electricity and electronics how to write simple code. I happen to use rather old versions of **SPICE**, version 2g6 being my "go to" application when I only require text-based output. **NGSPICE** (version 26), which is based on Berkeley **SPICE** version 3f5, is used when I require graphical output for such things as time-domain waveforms and Bode plots. In all **SPICE** example netlists I strive to use coding conventions compatible with all **SPICE** versions.

Andrew D. Hwang's ePiX mathematical visualization programming library

This amazing project is a **C++** library you may link to any **C/C++** code for the purpose of generating PostScript graphic images of mathematical functions. As a completely free and open-source project, it does all the plotting I would otherwise use a Computer Algebra System (CAS) such as **Mathematica** or **Maple** to do. It should be said that **ePiX** is *not* a Computer Algebra System like **Mathematica** or **Maple**, but merely a mathematical *visualization* tool. In other words, it won't determine integrals for you (you'll have to implement that in your own **C/C++** code!), but it can graph the results, and it does so beautifully. What I really admire about **ePiX** is that it is a **C++** programming library, which means it builds on the existing power and toolset available with that programming language. Mr. Hwang could have probably developed his own stand-alone application for mathematical plotting, but by creating a **C++** library to do the same thing he accomplished something much greater.

gnuplot mathematical visualization software

Another open-source tool for mathematical visualization is `gnuplot`. Interestingly, this tool is *not* part of Richard Stallman’s GNU project, its name being a coincidence. For this reason the authors prefer “gnu” *not* be capitalized at all to avoid confusion. This is a much “lighter-weight” alternative to a spreadsheet for plotting tabular data, and the fact that it easily outputs directly to an X11 console or a file in a number of different graphical formats (including PostScript) is very helpful. I typically set my `gnuplot` output format to default (X11 on my Linux PC) for quick viewing while I’m developing a visualization, then switch to PostScript file export once the visual is ready to include in the document(s) I’m writing. As with my use of `Gimp` to do rudimentary image editing, my use of `gnuplot` only scratches the surface of its capabilities, but the important points are that it’s *free* and that it *works well*.

Python programming language

Both Python and C++ find extensive use in these modules as instructional aids and exercises, but I’m listing Python here as a *tool* for myself because I use it almost daily as a *calculator*. If you open a Python interpreter console and type `from math import *` you can type mathematical expressions and have it return results just as you would on a hand calculator. Complex-number (i.e. *phasor*) arithmetic is similarly supported if you include the complex-math library (`from cmath import *`). Examples of this are shown in the Programming References chapter (if included) in each module. Of course, being a fully-featured programming language, Python also supports conditionals, loops, and other structures useful for calculation of quantities. Also, running in a console environment where all entries and returned values show as text in a chronologically-ordered list makes it easy to copy-and-paste those calculations to document exactly how they were performed.

Appendix D

Creative Commons License

Creative Commons Attribution 4.0 International Public License

By exercising the Licensed Rights (defined below), You accept and agree to be bound by the terms and conditions of this Creative Commons Attribution 4.0 International Public License (“Public License”). To the extent this Public License may be interpreted as a contract, You are granted the Licensed Rights in consideration of Your acceptance of these terms and conditions, and the Licensor grants You such rights in consideration of benefits the Licensor receives from making the Licensed Material available under these terms and conditions.

Section 1 – Definitions.

a. **Adapted Material** means material subject to Copyright and Similar Rights that is derived from or based upon the Licensed Material and in which the Licensed Material is translated, altered, arranged, transformed, or otherwise modified in a manner requiring permission under the Copyright and Similar Rights held by the Licensor. For purposes of this Public License, where the Licensed Material is a musical work, performance, or sound recording, Adapted Material is always produced where the Licensed Material is synched in timed relation with a moving image.

b. **Adapter’s License** means the license You apply to Your Copyright and Similar Rights in Your contributions to Adapted Material in accordance with the terms and conditions of this Public License.

c. **Copyright and Similar Rights** means copyright and/or similar rights closely related to copyright including, without limitation, performance, broadcast, sound recording, and Sui Generis Database Rights, without regard to how the rights are labeled or categorized. For purposes of this Public License, the rights specified in Section 2(b)(1)-(2) are not Copyright and Similar Rights.

d. **Effective Technological Measures** means those measures that, in the absence of proper authority, may not be circumvented under laws fulfilling obligations under Article 11 of the WIPO Copyright Treaty adopted on December 20, 1996, and/or similar international agreements.

e. **Exceptions and Limitations** means fair use, fair dealing, and/or any other exception or

limitation to Copyright and Similar Rights that applies to Your use of the Licensed Material.

f. **Licensed Material** means the artistic or literary work, database, or other material to which the Licensor applied this Public License.

g. **Licensed Rights** means the rights granted to You subject to the terms and conditions of this Public License, which are limited to all Copyright and Similar Rights that apply to Your use of the Licensed Material and that the Licensor has authority to license.

h. **Licensor** means the individual(s) or entity(ies) granting rights under this Public License.

i. **Share** means to provide material to the public by any means or process that requires permission under the Licensed Rights, such as reproduction, public display, public performance, distribution, dissemination, communication, or importation, and to make material available to the public including in ways that members of the public may access the material from a place and at a time individually chosen by them.

j. **Sui Generis Database Rights** means rights other than copyright resulting from Directive 96/9/EC of the European Parliament and of the Council of 11 March 1996 on the legal protection of databases, as amended and/or succeeded, as well as other essentially equivalent rights anywhere in the world.

k. **You** means the individual or entity exercising the Licensed Rights under this Public License. **Your** has a corresponding meaning.

Section 2 – Scope.

a. License grant.

1. Subject to the terms and conditions of this Public License, the Licensor hereby grants You a worldwide, royalty-free, non-sublicensable, non-exclusive, irrevocable license to exercise the Licensed Rights in the Licensed Material to:

A. reproduce and Share the Licensed Material, in whole or in part; and

B. produce, reproduce, and Share Adapted Material.

2. Exceptions and Limitations. For the avoidance of doubt, where Exceptions and Limitations apply to Your use, this Public License does not apply, and You do not need to comply with its terms and conditions.

3. Term. The term of this Public License is specified in Section 6(a).

4. Media and formats; technical modifications allowed. The Licensor authorizes You to exercise the Licensed Rights in all media and formats whether now known or hereafter created, and to make technical modifications necessary to do so. The Licensor waives and/or agrees not to assert any right or authority to forbid You from making technical modifications necessary to exercise the Licensed Rights, including technical modifications necessary to circumvent Effective Technological Measures.

For purposes of this Public License, simply making modifications authorized by this Section 2(a)(4) never produces Adapted Material.

5. Downstream recipients.

A. Offer from the Licensor – Licensed Material. Every recipient of the Licensed Material automatically receives an offer from the Licensor to exercise the Licensed Rights under the terms and conditions of this Public License.

B. No downstream restrictions. You may not offer or impose any additional or different terms or conditions on, or apply any Effective Technological Measures to, the Licensed Material if doing so restricts exercise of the Licensed Rights by any recipient of the Licensed Material.

6. No endorsement. Nothing in this Public License constitutes or may be construed as permission to assert or imply that You are, or that Your use of the Licensed Material is, connected with, or sponsored, endorsed, or granted official status by, the Licensor or others designated to receive attribution as provided in Section 3(a)(1)(A)(i).

b. Other rights.

1. Moral rights, such as the right of integrity, are not licensed under this Public License, nor are publicity, privacy, and/or other similar personality rights; however, to the extent possible, the Licensor waives and/or agrees not to assert any such rights held by the Licensor to the limited extent necessary to allow You to exercise the Licensed Rights, but not otherwise.

2. Patent and trademark rights are not licensed under this Public License.

3. To the extent possible, the Licensor waives any right to collect royalties from You for the exercise of the Licensed Rights, whether directly or through a collecting society under any voluntary or waivable statutory or compulsory licensing scheme. In all other cases the Licensor expressly reserves any right to collect such royalties.

Section 3 – License Conditions.

Your exercise of the Licensed Rights is expressly made subject to the following conditions.

a. Attribution.

1. If You Share the Licensed Material (including in modified form), You must:

A. retain the following if it is supplied by the Licensor with the Licensed Material:

i. identification of the creator(s) of the Licensed Material and any others designated to receive attribution, in any reasonable manner requested by the Licensor (including by pseudonym if designated);

ii. a copyright notice;

- iii. a notice that refers to this Public License;
- iv. a notice that refers to the disclaimer of warranties;
- v. a URI or hyperlink to the Licensed Material to the extent reasonably practicable;

B. indicate if You modified the Licensed Material and retain an indication of any previous modifications; and

C. indicate the Licensed Material is licensed under this Public License, and include the text of, or the URI or hyperlink to, this Public License.

2. You may satisfy the conditions in Section 3(a)(1) in any reasonable manner based on the medium, means, and context in which You Share the Licensed Material. For example, it may be reasonable to satisfy the conditions by providing a URI or hyperlink to a resource that includes the required information.

3. If requested by the Licensor, You must remove any of the information required by Section 3(a)(1)(A) to the extent reasonably practicable.

4. If You Share Adapted Material You produce, the Adapter's License You apply must not prevent recipients of the Adapted Material from complying with this Public License.

Section 4 – Sui Generis Database Rights.

Where the Licensed Rights include Sui Generis Database Rights that apply to Your use of the Licensed Material:

- a. for the avoidance of doubt, Section 2(a)(1) grants You the right to extract, reuse, reproduce, and Share all or a substantial portion of the contents of the database;
- b. if You include all or a substantial portion of the database contents in a database in which You have Sui Generis Database Rights, then the database in which You have Sui Generis Database Rights (but not its individual contents) is Adapted Material; and
- c. You must comply with the conditions in Section 3(a) if You Share all or a substantial portion of the contents of the database.

For the avoidance of doubt, this Section 4 supplements and does not replace Your obligations under this Public License where the Licensed Rights include other Copyright and Similar Rights.

Section 5 – Disclaimer of Warranties and Limitation of Liability.

a. Unless otherwise separately undertaken by the Licensor, to the extent possible, the Licensor offers the Licensed Material as-is and as-available, and makes no representations or warranties of any kind concerning the Licensed Material, whether express, implied, statutory, or other. This includes, without limitation, warranties of title, merchantability, fitness for a particular purpose, non-infringement, absence of latent or other defects, accuracy, or the presence or absence of errors,

whether or not known or discoverable. Where disclaimers of warranties are not allowed in full or in part, this disclaimer may not apply to You.

b. To the extent possible, in no event will the Licensor be liable to You on any legal theory (including, without limitation, negligence) or otherwise for any direct, special, indirect, incidental, consequential, punitive, exemplary, or other losses, costs, expenses, or damages arising out of this Public License or use of the Licensed Material, even if the Licensor has been advised of the possibility of such losses, costs, expenses, or damages. Where a limitation of liability is not allowed in full or in part, this limitation may not apply to You.

c. The disclaimer of warranties and limitation of liability provided above shall be interpreted in a manner that, to the extent possible, most closely approximates an absolute disclaimer and waiver of all liability.

Section 6 – Term and Termination.

a. This Public License applies for the term of the Copyright and Similar Rights licensed here. However, if You fail to comply with this Public License, then Your rights under this Public License terminate automatically.

b. Where Your right to use the Licensed Material has terminated under Section 6(a), it reinstates:

1. automatically as of the date the violation is cured, provided it is cured within 30 days of Your discovery of the violation; or

2. upon express reinstatement by the Licensor.

For the avoidance of doubt, this Section 6(b) does not affect any right the Licensor may have to seek remedies for Your violations of this Public License.

c. For the avoidance of doubt, the Licensor may also offer the Licensed Material under separate terms or conditions or stop distributing the Licensed Material at any time; however, doing so will not terminate this Public License.

d. Sections 1, 5, 6, 7, and 8 survive termination of this Public License.

Section 7 – Other Terms and Conditions.

a. The Licensor shall not be bound by any additional or different terms or conditions communicated by You unless expressly agreed.

b. Any arrangements, understandings, or agreements regarding the Licensed Material not stated herein are separate from and independent of the terms and conditions of this Public License.

Section 8 – Interpretation.

a. For the avoidance of doubt, this Public License does not, and shall not be interpreted to, reduce, limit, restrict, or impose conditions on any use of the Licensed Material that could lawfully

be made without permission under this Public License.

b. To the extent possible, if any provision of this Public License is deemed unenforceable, it shall be automatically reformed to the minimum extent necessary to make it enforceable. If the provision cannot be reformed, it shall be severed from this Public License without affecting the enforceability of the remaining terms and conditions.

c. No term or condition of this Public License will be waived and no failure to comply consented to unless expressly agreed to by the Licensor.

d. Nothing in this Public License constitutes or may be interpreted as a limitation upon, or waiver of, any privileges and immunities that apply to the Licensor or You, including from the legal processes of any jurisdiction or authority.

Creative Commons is not a party to its public licenses. Notwithstanding, Creative Commons may elect to apply one of its public licenses to material it publishes and in those instances will be considered the “Licensor.” Except for the limited purpose of indicating that material is shared under a Creative Commons public license or as otherwise permitted by the Creative Commons policies published at creativecommons.org/policies, Creative Commons does not authorize the use of the trademark “Creative Commons” or any other trademark or logo of Creative Commons without its prior written consent including, without limitation, in connection with any unauthorized modifications to any of its public licenses or any other arrangements, understandings, or agreements concerning use of licensed material. For the avoidance of doubt, this paragraph does not form part of the public licenses.

Creative Commons may be contacted at creativecommons.org.

Appendix E

References

“Allowable CT Secondary Lead Lengths for Automatic Capacitor Bank and Harmonic Filter Bank Controllers”, Northeast Power Systems, Inc., Queensbury, NY, 1999-2012.

Blackburn, J. Lewis and Domin, Thomas J., *Protective Relaying Principles and Applications*, Third Edition, CRC Press, Taylor & Francis Group, Boca Raton, FL, 2007.

“CT Application Guide for the 489 Generator Management Relay”, GE Publication number GET-8402, General Electric Power Managements, 2002.

“CVT Capacitor Voltage Transformer and CC Coupling and TRV Capacitors”, E 214.52 NA, Trench Group, Feb 2012.

Dalziel, Charles F., *Deleterious Effects of Electric Shock*, University of California, Berkeley, CA, October 1961.

Ganesan, Sethuraman, “Selection of Current Transformers & Wire Sizing in Substations”, ABB Inc., Allentown, PA.

IEEE C57.13.3-2005, IEEE Guide for Grounding of Instrument Transformer Secondary Circuits and Cases, IEEE Power Engineering Society, New York, NY, 2005.

“Instrument Transformer Basic Technical Information and Application”, General Electric Company.

“Instrument Transformers Buyer’s Guide”, GE Meter, Somersworth, NH.

Jones, Kent, “Instrument Transformer Basics”, Line Power Manufacturing.

NFPA 70E Standard for Electrical Safety in the Workplace, 2015 Edition, NFPA, Quincy, MA, 2016.

Appendix F

Version history

This is a list showing all significant additions, corrections, and other edits made to this learning module. Each entry is referenced by calendar date in reverse chronological order (newest version first), which appears on the front cover of every learning module for easy reference. Any contributors to this open-source document are listed here as well.

17 February 2025 – added a new Technical References section on transformer parasitics.

18 December 2024 – added a photograph to the “Instrument transformer test switches” section of the Tutorial chapter showing a CT test probe inserted into an opened CT test switch, modified an existing photograph, and added some more explanatory text to that section.

16 November 2024 – divided the Introduction chapter into sections, one with recommendations for students, one with a listing of challenging concepts, and one with recommendations for instructors.

6 December 2023 – added more instructor notes to the “Transformer-isolated voltage calculations” Quantitative Reasoning question.

28 November 2022 – placed questions at the top of the itemized list in the Introduction chapter prompting students to devise experiments related to the tutorial content.

8 December 2021 – emphasized the use of *meters* for saturation testing of CTs in the Tutorial.

9 July 2021 – replaced some TeX-style italicizing markup with LaTeX-style.

8 May 2021 – commented out or deleted empty chapters.

27 April 2021 – significantly edited the Introduction chapter to make it more suitable as a pre-study guide and to provide cues useful to instructors leading “inverted” teaching sessions. Also corrected an error in the instructor notes.

25 April 2021 – changed title of a Quantitative Reasoning question from “CT wiring to a relay” to “Multi-ratio CT wiring”

17 April 2021 – added questions, and also split the “Instrument transformer test switches” section into two sections, with the new section devoted to terminal blocks.

1 January 2019 – added a Technical Reference section on electrical safety.

5 November 2018 – retitled Historical References section(s) so as to not be redundant to the “Historical References” chapter.

September 2018 – renamed “Derivations and Technical References” chapter to “Historical References”.

July 2018 – document first created.

Index

- Adding quantities to a qualitative problem, 88
- Alternating current, 47
- American Wire Gauge, 36
- Annotating diagrams, 87
- Arc, 49
- Arc blast, 53
- Arc flash, 49
- Arc flash boundary, 50
- Arc flash suit, 52
- AWG, 36

- Basic Insulation Level rating, 12
- BIL rating, 12
- Bonding, 48
- Boundary, arc flash, 50
- Boundary, limited approach, 50
- Boundary, restricted approach, 50
- Burden, instrument transformer, 29
- Busbar, 48

- Calorie, 52
- Capacitively-coupled voltage transformer (CCVT), 11
- CCVT, capacitively-coupled voltage transformer, 11
- Checking for exceptions, 88
- Checking your work, 88
- Circuit breaker, 47
- Code, computer, 95
- CT, 12
- Current source, 19
- Current transformer (CT), 12
- Current transformer (CT) safety, 20
- Current, excitation, 57
- Current, magnetization, 57

- Dalziel, Charles, 46

- Dimensional analysis, 87
- Direct current, 47
- Disconnect switch, 48

- Edwards, Tim, 96
- Electric shock, 46
- Electrically common points, 48
- Equipotential, 48
- Excitation current, 57

- Faraday's Law of Electromagnetic Induction, 31, 57
- Frequency, 47
- Fuse, 47

- Gauge, American Wire, 36
- Graph values to solve a problem, 88
- Greenleaf, Cynthia, 59
- Ground loop, 20

- Hertz, 47
- How to teach with these modules, 90
- Hwang, Andrew D., 97

- Identify given data, 87
- Identify relevant principles, 87
- Inductive reactance, 57
- Instructions for projects and experiments, 91
- Intermediate results, 87
- Inverted instruction, 90
- Ionized air, 49

- Knuth, Donald, 96

- Lamport, Leslie, 96
- Limited approach boundary, 50
- Limiting cases, 88
- Load, 46

- Lock-out, tag-out, [50](#)
- LOTO, [50](#)
- Magnetic remanence, [33](#)
- Magnetization current, [57](#)
- Make-before-break switch contacts, [23](#)
- Maxwell, James Clerk, [43](#)
- Metacognition, [64](#)
- Moolenaar, Bram, [95](#)
- Murphy, Lynn, [59](#)
- National Fire Protection Association, [50](#)
- Nervous system, [46](#)
- NFPA, [50](#)
- NFPA 70E, [50](#)
- One-Hand Rule, [49](#)
- Open-source, [95](#)
- Parasitic effect, [54](#)
- Potential transformer (PT), [8](#)
- Potential transformer (PT) safety, [20](#)
- Primary injection test, current transformer, [34](#)
- Problem-solving: annotate diagrams, [87](#)
- Problem-solving: check for exceptions, [88](#)
- Problem-solving: checking work, [88](#)
- Problem-solving: dimensional analysis, [87](#)
- Problem-solving: graph values, [88](#)
- Problem-solving: identify given data, [87](#)
- Problem-solving: identify relevant principles, [87](#)
- Problem-solving: interpret intermediate results, [87](#)
- Problem-solving: limiting cases, [88](#)
- Problem-solving: qualitative to quantitative, [88](#)
- Problem-solving: quantitative to qualitative, [88](#)
- Problem-solving: reductio ad absurdum, [88](#)
- Problem-solving: simplify the system, [87](#)
- Problem-solving: thought experiment, [87](#)
- Problem-solving: track units of measurement, [87](#)
- Problem-solving: visually represent the system, [87](#)
- Problem-solving: work in reverse, [88](#)
- PT, potential transformer, [8](#)
- Qualitatively approaching a quantitative problem, [88](#)
- Reactance, inductive, [57](#)
- Reading Apprenticeship, [59](#)
- Reductio ad absurdum, [88–90](#)
- Remanence, CT, [33](#)
- Resistance, wire, [36](#)
- Restricted approach boundary, [50](#)
- Safety disconnect switch, [48](#)
- Safety, instrument transformer, [20](#)
- Schoenbach, Ruth, [59](#)
- Scientific method, [64](#)
- Shock, electric, [46](#)
- Simplifying a system, [87](#)
- Socrates, [89](#)
- Socratic dialogue, [90](#)
- Spark, [49](#)
- SPICE, [59](#)
- SPST switch contacts, [22](#)
- Stallman, Richard, [95](#)
- Switch, disconnect, [48](#)
- Test switch, power instrumentation, [21](#)
- Thought experiment, [87](#)
- Torvalds, Linus, [95](#)
- Units of measurement, [87](#)
- Visualizing a system, [87](#)
- Voltage source, [19](#)
- Voltage transformer (VT), [8](#)
- VT, voltage transformer, [8](#)
- Westinghouse model CO-11 overcurrent relay, [31](#)
- Wire resistance, [36](#)
- Work in reverse to solve a problem, [88](#)
- WYSIWYG, [95, 96](#)