

MODULAR ELECTRONICS LEARNING (MODEL) PROJECT



TRANSFORMERS

© 2018-2024 BY TONY R. KUPHALDT – UNDER THE TERMS AND CONDITIONS OF THE
CREATIVE COMMONS ATTRIBUTION 4.0 INTERNATIONAL PUBLIC LICENSE

LAST UPDATE = 9 NOVEMBER 2024

This is a copyrighted work, but licensed under the Creative Commons Attribution 4.0 International Public License. A copy of this license is found in the last Appendix of this document. Alternatively, you may visit <http://creativecommons.org/licenses/by/4.0/> or send a letter to Creative Commons: 171 Second Street, Suite 300, San Francisco, California, 94105, USA. The terms and conditions of this license allow for free copying, distribution, and/or modification of all licensed works by the general public.

Contents

1	Introduction	3
1.1	Recommendations for students	3
1.2	Challenging concepts related to transformers	5
1.3	Recommendations for instructors	6
2	Case Tutorial	9
2.1	Example: step-up power transformer	10
2.2	Example: step-down power transformer	11
2.3	Example: transformer testing using a loudspeaker	12
2.4	Example: multi-voltage transformer wiring	13
2.5	Example: current transformer (CT) and potential transformer (PT)	14
2.6	Example: boost/buck transformer wiring	15
2.7	Example: power transformer photos	18
2.8	Example: sensitive audio detector circuit	23
3	Simplified Tutorial	27
4	Full Tutorial	37
4.1	Basic transformer operation	37
4.2	Loading effects	40
4.3	Step ratios	42
4.4	Winding polarity	46
4.5	Transformer power ratings	52
4.6	Power transformer impedance ratings	53
4.7	Impedance transformation	56
4.8	Transformer applications	59
4.9	Transformer construction	62
5	Historical References	65
5.1	The first transformer	66
5.2	Prototype electrical power transmission system	67
5.3	Early transformer core construction	68

6	Derivations and Technical References	69
6.1	Magnetic field quantities	70
6.2	Calculating winding turns	80
6.3	Transformer parasitics	84
6.3.1	Parasitic resistance in transformers	85
6.3.2	Leakage inductance in transformers	85
6.3.3	Parasitic capacitance in transformers	86
6.3.4	Excitation and magnetization currents	87
6.3.5	Transformer testing	88
6.4	Manufacturing shell-type transformers	89
6.5	Manufacturing toroidal transformers	92
7	Questions	95
7.1	Conceptual reasoning	99
7.1.1	Reading outline and reflections	100
7.1.2	Foundational concepts	101
7.1.3	Gaulard and Gibbs transformer	103
7.1.4	Leakage inductance	104
7.1.5	Explaining the meaning of calculations	105
7.1.6	Industrial control power transformer	107
7.1.7	Boost/buck transformer circuits	109
7.1.8	Multi-wire secondary connections	110
7.2	Quantitative reasoning	111
7.2.1	Miscellaneous physical constants	112
7.2.2	Introduction to spreadsheets	113
7.2.3	Basic transformer calculations	116
7.2.4	Autotransformer currents	118
7.2.5	Transformer-resistor circuit	119
7.2.6	Measuring transformer impedance	119
7.3	Diagnostic reasoning	120
7.3.1	Faulted transformer-lamp circuit	121
7.3.2	Testing transformer polarity	121
A	Problem-Solving Strategies	123
B	Instructional philosophy	125
C	Tools used	131
D	Creative Commons License	135
E	References	143
F	Version history	145
	Index	147

Chapter 1

Introduction

1.1 Recommendations for students

The *transformer* is one of the most important components in all of AC circuitry. Principally used to “step” between different values of AC voltage and current in power systems, transformers find uses in many other types of circuits including electronic amplifiers (for impedance matching) and even sensor circuits (sensing physical position).

Important concepts related to transformers include **sources** versus **loads**, **self-inductance**, **mutual inductance**, the **Conservation of Energy**, **Ohm’s Law**, **Joule’s Law**, **Faraday’s Law of Electromagnetic Induction**, **magnetic flux**, **primary** versus **secondary** windings, **impedance**, **coupling**, **isolation**, and the effects of **opens** versus **shorts**.

Here are some good questions to ask of yourself while studying this subject:

- How might an experiment be designed and conducted to demonstrate the phenomenon of mutual inductance? What hypothesis (i.e. prediction) might you pose for that experiment, and what result(s) would either support or disprove that hypothesis?
- How might an experiment be designed and conducted to measure the turns ratio of a transformer? What hypothesis (i.e. prediction) might you pose for that experiment, and what result(s) would either support or disprove that hypothesis?
- What are some practical applications of transformers?
- What does it mean to say that energy is always *conserved*?
- How does an electrical load behave?
- How does an electrical source behave?
- What are some examples of electrical components capable of being either sources or loads?
- What exactly is a *rate of change*?

- Why would a device like a transformer have *polarity* markings, when we generally only use them with AC and not DC?
- How may we test the polarity of an unmarked transformer?
- What determines the “step” ratio of a transformer?
- How does an “autotransformer” differ from a regular transformer?
- What does it mean for a transformer to either buck or boost voltage?
- Why is the “impedance” rating of a power transformer important?
- Which provides a “stiffer” voltage source, a transformer with a large or small impedance value?
- Which is able to source greater current to a short-circuit fault, a transformer with a large or small impedance value?
- What factor(s) dictate the peak value of magnetic flux within the core of a transformer energized by an AC voltage source?
- What factor(s) dictate the peak value of magnetic flux within the core of a transformer energized by an AC current source?
- In what way is a current transformer (CT) dangerous that a regular voltage-based transformer is not?
- How exactly might a transformer be damaged by excessive voltage?
- How exactly might a transformer be damaged by excessive current?

1.2 Challenging concepts related to transformers

The following list cites concepts related to this module's topic that are easily misunderstood, along with suggestions for properly understanding them:

- **Parasitic effects** – phenomena such as resistance, capacitance, and inductance don't just exist where we want them to, but in fact always exist everywhere they can. All conductors (except for superconductors) have some amount of resistance, all conductors separated by an insulating gap exhibit capacitance, and all conductors possess inductance by virtue of their ability to produce a magnetic field with the passage of current. Often these "parasitic" effects are small enough to ignore, but in some applications they may be severe.
- **Rates of change** – when learning the relationships between voltage and current for inductors and capacitors, one must think in terms of how fast a variable is changing. The amount of voltage induced across an inductor is proportional to how *quickly* the current through it changes, not how strong the current is. Likewise, the amount of current "through" a capacitor is proportional to how *quickly* the voltage across it changes. This is the first hurdle in calculus: to comprehend what a rate of change is, and it is far from obvious. A helpful strategy here is to relate electrical rates of change to other, more common, rates of change such as *speed* (i.e. the rate-of-change of physical position over time). Also helpful is to relate rates of change to the *slope* of a line or curve plotted on a graph, showing how *rise/fall over run* describes not only the phenomenon of a rate-of-change but also the appropriate units of measurement.
- **Turns ratios for voltage and current** – many transformer problems are nothing more than exercises in mathematical ratios. Once students become comfortable manipulating these ratios to solve for voltages, currents, and/or winding turns, it is easy. Unfortunately, it is also very easy to accidentally reverse the ratios (e.g. 3 to 1 instead of 1 to 3). With regard to voltage and current for both sides of a transformer, there is a very simple way to check your work. Like all passive devices, transformers can never output more power than they input. And because they are efficient, their output power is rarely less than 90% of their input power. For many practice problems, 100% efficiency is assumed, so output power must be the same as input power. To check your voltage and current calculations, figure out primary power from primary voltage and primary current, then do the same for the secondary side. The two power calculations should always match because energy must always be conserved!
- **Hazards of line-powered circuits** – students build a line-powered AC power supply must review the principles of electrical safety. Unlike many of the projects and experiments students of electronics first build, a line-powered circuit can shock and even kill you! Lock-out/Tag-out procedures are good to use in these cases.
- **Autotransformers** – an autotransformer is a transformer using a single winding rather than two or more electrically-isolated windings. By tapping into the one winding it becomes possible to power the load from a different number of turns than what the source connects to, thereby granting a step ratio for voltage and current. That step ratio is still calculated on the basis of load winding turns versus source winding turns, the only difference being a lack of electrical isolation between source and load because the smaller of those turns are shared with both circuits.

1.3 Recommendations for instructors

This section lists realistic student learning outcomes supported by the content of the module as well as suggested means of assessing (measuring) student learning. The outcomes state what learners should be able to do, and the assessments are specific challenges to prove students have learned.

- **Outcome** – Demonstrate effective technical reading and writing
 - Assessment – Students present their outlines of this module’s instructional chapters (e.g. Case Tutorial, Tutorial, Historical References, etc.) ideally as an entry to a larger Journal document chronicling their learning. These outlines should exhibit good-faith effort at summarizing major concepts explained in the text.
 - Assessment – Students show how voltages and current calculations were obtained by the author in the Tutorial chapter’s examples.
- **Outcome** – Apply the concept of turns ratio to AC transformer circuit calculations
 - Assessment – Calculate turns ratio, voltages, and/or currents for a transformer circuit given the other necessary parameters; e.g. pose problems in the form of the “Basic transformer calculations” Quantitative Reasoning question.
- **Outcome** – Analyze boost-buck transformer circuits based on winding polarities
 - Assessment – Predict whether a given circuit will boost source voltage or reduce source voltage given winding polarity symbols; e.g. pose problems in the form of the “Boost/buck transformer circuits” Conceptual Reasoning question.
- **Outcome** – Prove the concept of transformer turns ratios by experiment
 - Assessment – Design and conduct an experiment to determine the turns ratio of a transformer from voltage measurements.
- **Outcome** – Prove the concept of transformer winding polarity by experiment
 - Assessment – Design and conduct an experiment to determine the polarity relationships between a transformer’s multiple windings.
- **Outcome** – Prove the concept of transformer impedance by experiment
 - Assessment – Design and conduct an experiment to determine the impedance percentage of a transformer based on loaded versus unloaded tests.
- **Outcome** – Independent research
 - Assessment – Read and summarize in your own words reliable source documents on the history of electric power systems around the world. Recommended readings include *The Alternating Current Transformer In Theory And Practice, volumes 1 and 2* by John Ambrose Fleming.

Assessment – Locate transformer datasheets and properly interpret some of the information contained in those documents including turns ratio, winding configurations, winding polarities, voltage ratings, current ratings, power ratings, etc.

Chapter 2

Case Tutorial

The idea behind a *Case Tutorial* is to explore new concepts by way of example. In this chapter you will read less presentation of theory compared to other Tutorial chapters, but by close observation and comparison of the given examples be able to discern patterns and principles much the same way as a scientific experimenter. Hopefully you will find these cases illuminating, and a good supplement to text-based tutorials.

These examples also serve well as challenges following your reading of the other Tutorial(s) in this module – can you explain *why* the circuits behave as they do?

2.1 Example: step-up power transformer

All voltage and current measurements are shown as RMS values, for an ideal transformer:

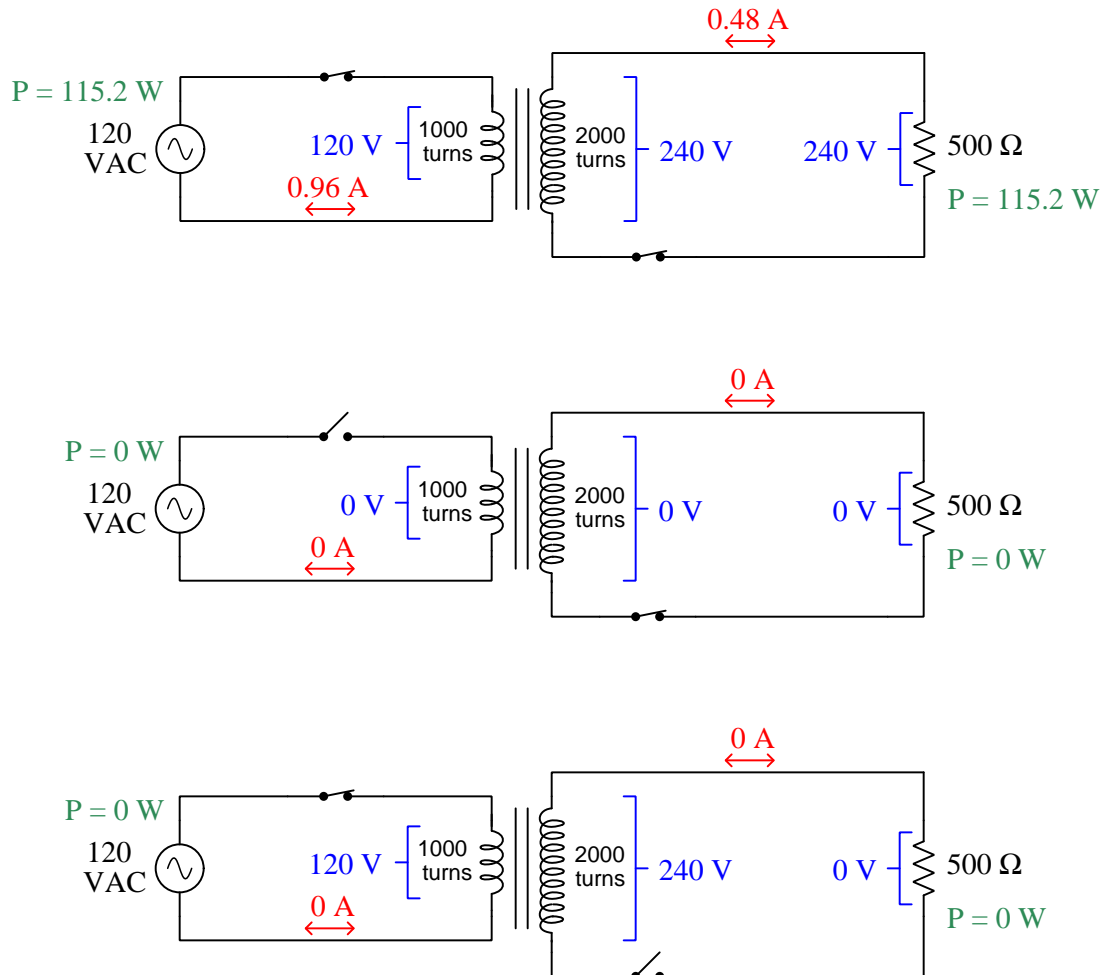

The most significant difference between the values presented in this example and the measured values for a real power transformer would be primary current in the bottom schematic, where the primary switch is closed but zero current flows through the primary winding (because the secondary circuit is open). For a real transformer this primary current will be non-zero, and is called *magnetizing current*. It represents the amount of current necessary through the transformer's primary winding to establish equilibrium with the applied AC voltage.

2.2 Example: step-down power transformer

All voltage and current measurements are shown as RMS values, for an ideal transformer:

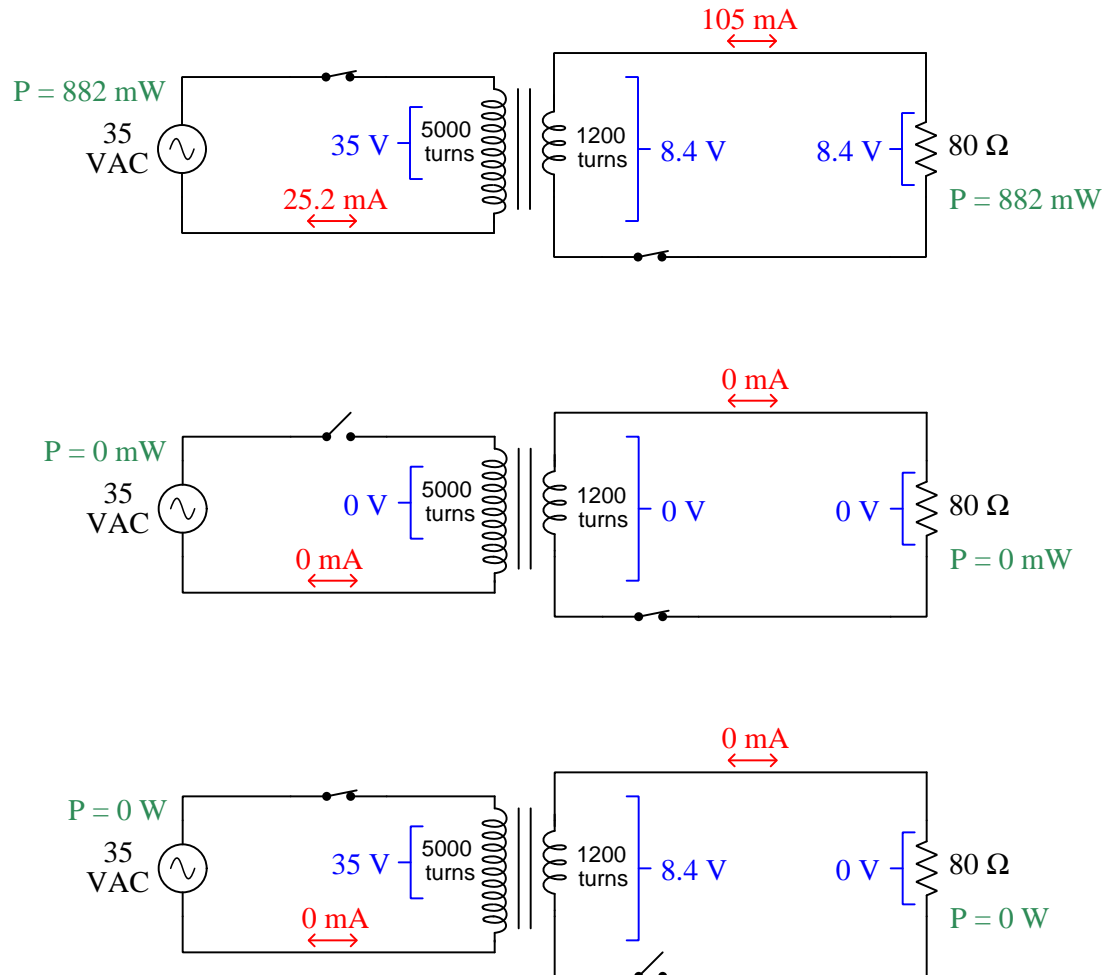

The most significant difference between the values presented in this example and the measured values for a real power transformer would be primary current in the bottom schematic, where the primary switch is closed but zero current flows through the primary winding (because the secondary circuit is open). For a real transformer this primary current will be non-zero, and is called *magnetizing current*. It represents the amount of current necessary through the transformer's primary winding to establish equilibrium with the applied AC voltage.

2.3 Example: transformer testing using a loudspeaker

A simple way to test a transformer for winding turns ratio and winding polarity is to energize its primary winding using a pulsed voltage source while monitoring both the primary and secondary windings with an oscilloscope configured for “single” sweep mode where it captures and freezes a transient¹ signal. By comparing the amplitudes of the primary versus secondary winding voltage pulses, it is easy to compute turns ratio. The relative phase of these two pulse signals will indicate winding polarity.

An extremely simple source of signal pulses is a loudspeaker when its cone is gently tapped using your finger. This will generate decaying AC pulse waveforms suitable for transformer testing, with amplitudes low enough as to be all but impossible to over-power, permanently magnetize, saturate, or otherwise subject the transformer to harm. The following illustration shows how this may be done, tapping the speaker cone to generate the small voltage transients and using a digital oscilloscope to capture these transients (in single-sweep mode):

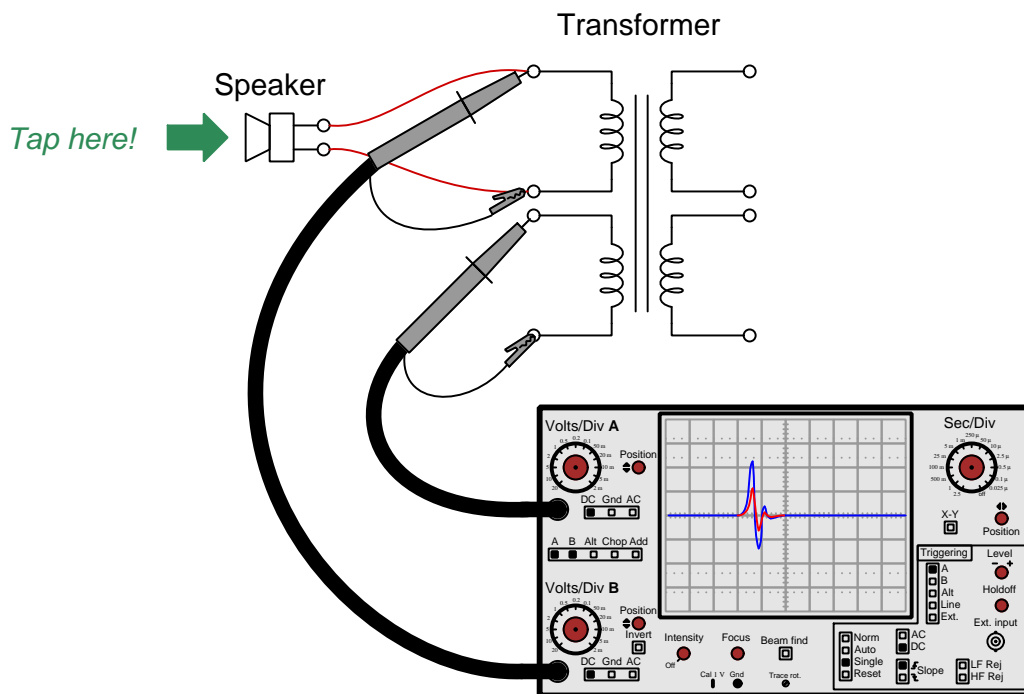

Turns ratio may be determined by calculating the ratio of signal peak values. Winding polarity, of course, is relative: a dot or other distinct marking one of the two wires for each winding denotes which wires between windings will exhibit the same polarity at any given time. In the example shown above, we could legitimately mark both of the tested windings’ upper wires with dots, or both of their lower wires with dots, because the two transient signals captured by the oscilloscope are in-phase with each other.

¹A “transient” signal is one that is fleeting – it comes and goes very quickly.

2.4 Example: multi-voltage transformer wiring

Small power transformers used to step down AC voltage for industrial control circuits usually have *four* windings: two primary and two secondary. The reason for this plurality of primary and secondary windings is to provide a range of user-selectable options for voltage step-down ratios. The following example shows such a “control power transformer” with two primary windings rated at 240 Volts each, and two secondary windings rated at 120 Volts each. By connecting primary windings either in series or in parallel with each other, and connecting secondary windings either in series or parallel with each other, four different input/output voltage combinations are possible:

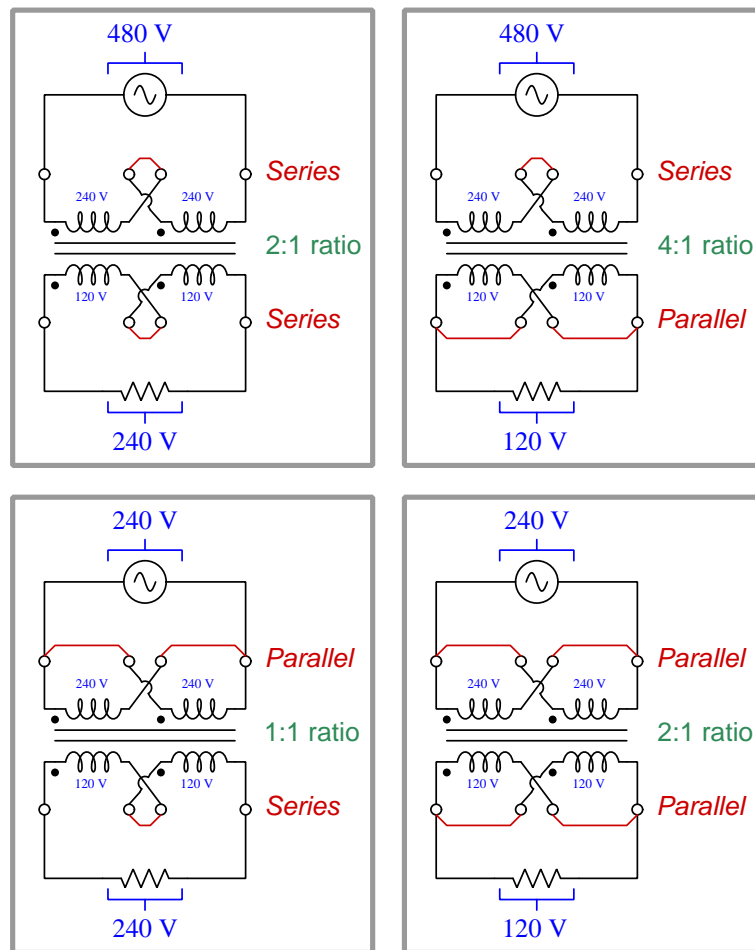

These options mean an end-user who needs to step 480 Volts down to 240 Volts, or another who needs to step down 240 Volts to 120 Volts, or anyone else needing any of the other options for their application, can all use the exact same model of control power transformer!

2.5 Example: current transformer (CT) and potential transformer (PT)

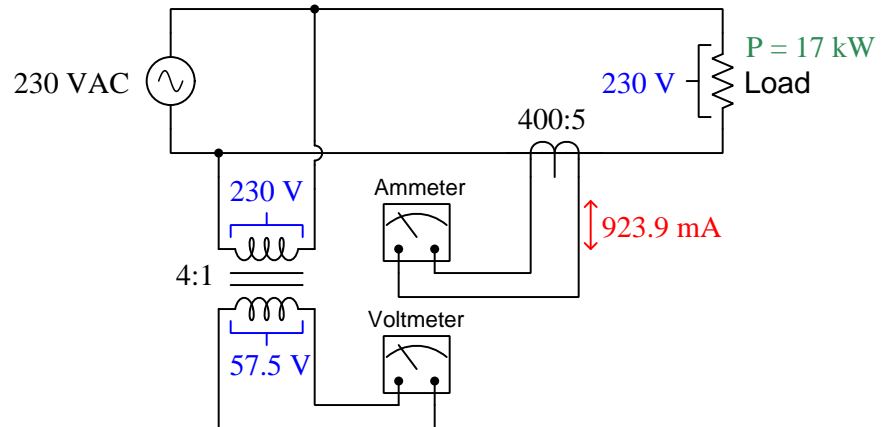

2.6 Example: boost/buck transformer wiring

Most any step-down transformer may be used as either a *buck* or *boost* autotransformer by connecting its secondary winding to one side of the primary circuit so that the secondary winding's voltage either subtracts from (buck) or adds to (boost) the primary's source voltage:

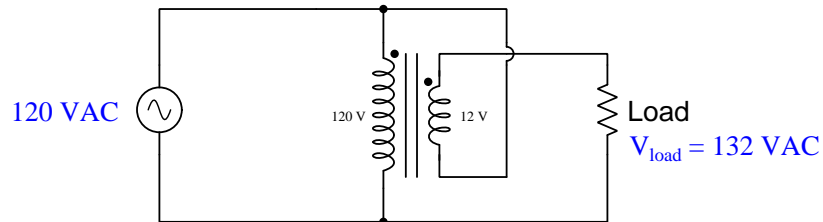
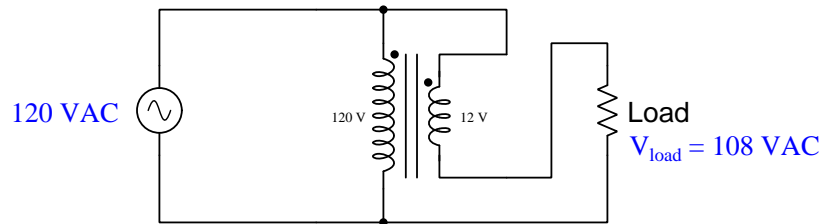

If we connect one of the secondary windings in series with the primary so that the primary winding receives less than the full line voltage, we find another option for boosting and bucking voltage:

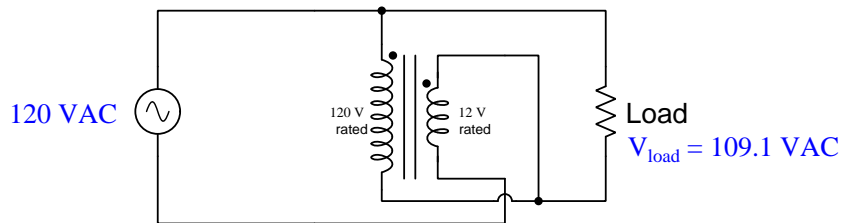

In this configuration, the 120-Volt-rated primary winding only experiences 109.1 Volts and the 12-Volt-rated secondary winding only experiences 10.91 Volts.

A possible variation on this last theme is to reverse the polarity of the secondary winding so that it cancels out turns in the primary winding, but this is only practical when we know for sure that the source voltage will not over-excite the primary winding:

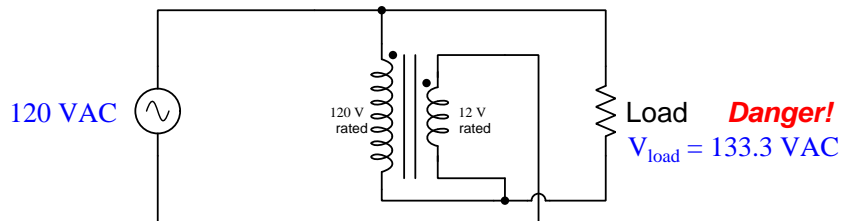

The danger here is magnetic saturation of the transformer's core, resulting in excessive magnetization current through the primary winding as well as excessive heating of the iron core. Most power transformers are conservatively designed, and some may have enough magnetic "headroom" in their design to handle the over-voltage, but one should not assume this is the case without empirically testing the transformer to find its saturation limits. A safer implementation of this boost configuration would be to use a transformer rated for 240/24 Volts rather than 120/12 Volts, so that neither winding's voltage rating would be exceeded. As shown, the primary winding will experience 133.3 Volts while the secondary winding will experience 13.33 Volts.

If we have access to a multi-secondary power transformer, other boost/buck options become possible:

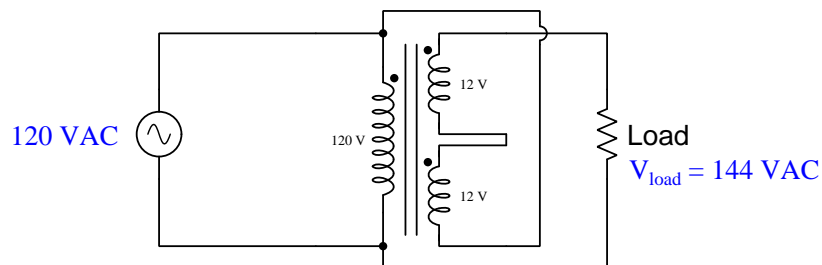
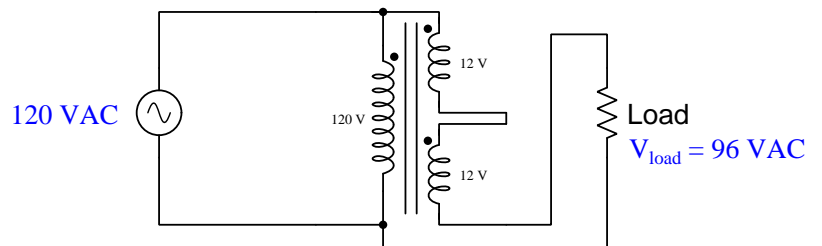

Using one of the secondary windings to reduce the primary winding's voltage, and the other secondary winding to add or subtract voltages:

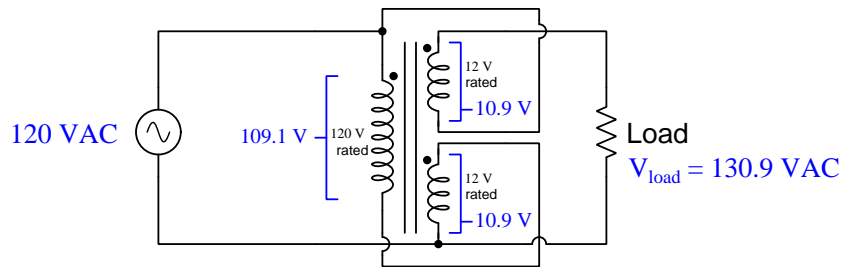
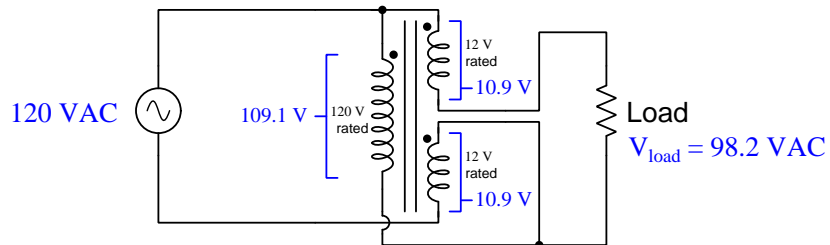

Using both of the secondary windings to reduce the primary winding's voltage, we find other possible output voltages:

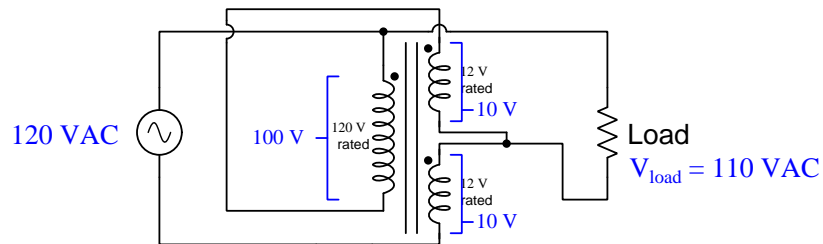
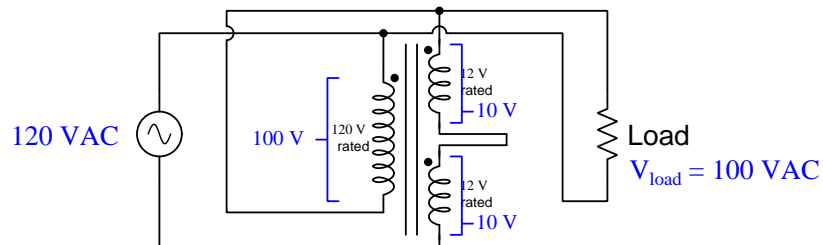

2.7 Example: power transformer photos

Transformer are used extensively in large-scale electric power systems to facilitate transmission and distribution, the core principle being to step voltage up (and current down) so that thinner conductors may be used to convey the same amount of power economically over long distances, then other transformers step voltage down (and current up) for safer end-use of that electricity.

The following photograph shows a large bank of step-up transformers located at Grand Coulee hydroelectric dam in Washington state, the transformers painted green in color:



Each of those transformers steps 13.8 kiloVolts received from the AC generators up to 500 kiloVolts for transmission purposes. The devices labeled *disconnects* are large manually-operated switches designed to disconnect each transformer from the *bus* (a set of three conductors paralleling the generators together). Air-blast style *circuit breakers* stand between the disconnect switches and respective transformers, designed to automatically open to interrupt current in the event of a fault.

Transformers located at *substations* receive the high-voltage power and step that voltage down to lower levels. An example of a typical substation transformer appears below:



Each of the terminals located at the top of this transformer is called a *bushing*, the taller insulators being the connection points for the high-voltage (transmission-line) primary windings and the shorter insulators being the connection points for the lower-voltage (distribution-line) secondary windings. Whereas typical transmission line voltages in the United States are 250 kV and greater, distribution line voltages are usually 100 kV and less. Neighborhood lines often operate at 7.2 kV, with larger power lines joining city sections being higher voltage. Additional substations within a city contain step-down transformers bridging those lines.

The particular transformer shown has a primary voltage rating of 115 kiloVolts and a secondary voltage rating of 13.09 kiloVolts. Its rated power is 16.8 MVA, with an impedance of 6.60%. It would be found within a city substation, fed by a regional substation tasked with stepping down the 250 kiloVolt (or greater) transmission voltage to 115 kiloVolts.

A ground-mounted transformer typical of what might service a commercial building, school, or hospital is shown here, taking the distribution voltage (e.g. 7200 Volts) and stepping it down to something much lower, such as 480, 277, 240, and/or 120 Volts:



This particular transformer has a primary voltage rating of 7.2 kiloVolts and a secondary voltage rating of 240/120 Volts (center-tapped secondary winding), with a power rating of 37.5 kVA and an impedance of 1.5% as shown by this nameplate:

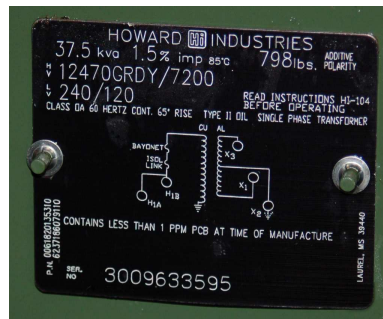

2.7. EXAMPLE: POWER TRANSFORMER PHOTOS

21

Individual residences and small businesses often use pole-mounted transformers which resemble grey-colored metal cans:



Each of these is filled with oil to displace atmospheric moisture from the windings and core of the transformer. With the lid removed, you can see the clear oil filling the interior volume of the transformer can, the actual transformer being submerged in the oil:



Shown below is a *line tap-changer* autotransformer, often referred to as a *LTC* in the power industry. It is used to boost or buck voltage at points along a power distribution network to compensate for different amounts of voltage “sag” at different times of day when customer loading increases and decreases. Inside the transformer is an oil-immersed switch assembly moved from position to position by a small electric motor and gear mechanism. That motor is energized by a control circuit monitoring the “load” side voltage of this transformer. If the load voltage sags too much, the tap-changing motor spins momentarily to move the switch to a different position where the winding turns ratio produces a higher output voltage, thereby helping the customers’ voltage remain steady.



2.8 Example: sensitive audio detector circuit

A useful project for sensing low-voltage signals is this “sensitive audio detector” circuit using headphones to convert electrical energy into acoustic energy you can hear:

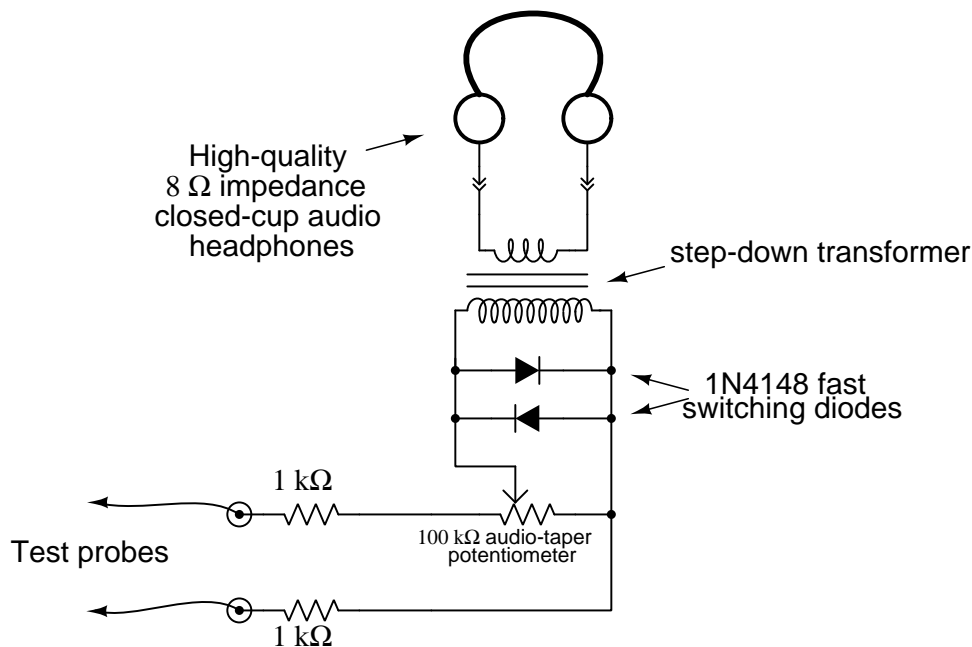

Any AC signal with a frequency between approximately 20 Hz and 20 kHz (depending on the range of your own hearing) may be heard using this test instrument. Such an audio detector is extremely useful for probing audio amplifier circuits, allowing you to hear the signal at different points along the amplification circuitry. With good-quality headphones or earbuds, the sensitivity is great enough to allow the user to hear 60 Hz electrical “noise” even without direct contact of the probes (e.g. grounding one probe and holding the other *near* the noise source, or connecting both probes to an inductive pick-up coil). Even DC signals may be sensed by listening for a “click” or “scratching” noise whenever the test probes come into contact with a DC voltage source.

An interesting application of this test instrument is as a *null detector* in precision electrical measurement circuits such as Wheatstone bridges, where its purpose is to aurally indicate a *lack* of electrical potential between two points. To use this as a null detector in a DC circuit, you must connect one of the test probes in series with a pushbutton switch or some other convenient means of disconnection and reconnection, in order to make small DC voltages/currents audible. For example, when used to sense voltage between the measurement points of a Wheatstone bridge circuit it will indicate a state of balance when it produces no sound at all in response to being connected and disconnected from those points. Any time the bridge is not perfectly balanced, there will be an audible “click” in the headphones/earbuds when connected and disconnected from the circuit even with currents less than one microAmpere.

The transformer acts to match the low impedance of the headphones (typically 8 Ohms) to a much greater impedance presented at the high-turns winding, this impedance transformation described by the following formula:

$$\frac{Z_P}{Z_S} = \left(\frac{N_P}{N_S} \right)^2$$

Where,

Z_P = impedance at transformer's primary winding, in Ohms

Z_S = impedance at transformer's secondary winding, in Ohms

N_P = number of turns within transformer's primary winding

N_S = number of turns within transformer's secondary winding

An excellent choice for this transformer is a reclaimed power transformer from a common household microwave oven. When microwave ovens fail, it is usually the magnetron tube or some other component, not the power transformer. With microwave ovens being so common in American households, it should be easy to recover a power transformer from one if needed. Normally, this type of transformer steps up 120 Volts AC from the home's power wiring to approximately 2 kV AC necessary to energize the oven's magnetron tube. Here, we are using it as a step-down transformer, a microwave oven transformer's high-voltage ratings providing excellent isolation for safety in this application, ensuring no conductive connection whatsoever between the headphones and the circuit under test. It is recommended that you cut the connection between one end of the microwave oven's high-voltage winding² and the iron core of the transformer, so that the high-voltage winding is completely isolated from the frame.

A transformer with a large iron core such as a microwave oven power transformer also helps make very low-voltage DC signals audible by its ability to *store energy*. When connecting the detector circuit to a DC source, the transformer will build up a magnetic field of one polarity corresponding to the polarity of the applied voltage. When the connection to the source is broken (by lifting one or both of the test probes away from the point(s) of contact), this magnetic field rapidly collapses and in doing so delivers all that stored energy over a brief time interval to the only load still connected: the headphones. Energy, of course, is always conserved, but it is possible for the transformer in this context to release more *power* (i.e. energy transfer per unit time) than it receives. Thus, in addition to providing safe electrical isolation between the circuit under test and the headphones, as well as impedance transformation for weak AC signals, the transformer also augments weak DC signals by its ability to inductively store (and rapidly release) energy.

The two parallel-connected diodes serve to limit the maximum amount of voltage across the transformer's primary winding. These silicon model 1N4148 diodes have a typical forward voltage of approximately 0.7 Volts, meaning neither is able to conduct electricity unless the voltage across it reaches this value (in the correct polarity). Thus, any voltage less than 0.7 Volts (peak) will pass to the transformer's primary winding unattenuated, but any signal voltage greater than this will become "clipped" to a maximum value of 0.7 Volts. If the perceived volume at this peak signal amplitude is still too loud, one may insert a series resistance between the diode pair and the

²This is typically how microwave oven power transformers are wired: with the high-voltage winding connected at one end to chassis ground. Here, we neither need nor want this feature, but instead would prefer an isolated winding.

transformer's primary winding, experimenting with this resistor's value until a suitable maximum volume is found

A potentiometer provides simple volume control, useful for attenuating volume when sensing stronger signals. The two resistors in series with the test probes provide a minimum resistance between the test probes and transformer winding to prevent the transformer from excessively loading the circuit under test, as well as provide a maximum volume limit for listening. You may find it possible to use series resistors much greater than 1 kiloOhm each if your headphones are sensitive and your sense of hearing is acute. A good practice is to set the potentiometer to a position of minimal volume when first testing a signal of unknown magnitude, so that the resulting volume produced by the headphones will not be too loud. This is analogous to setting a manually-ranged multimeter to the highest range when testing a voltage or current, so that if the signal happens to be stronger than expected the meter's pointer will not be violently thrown to maximum position on its scale.

Chapter 3

Simplified Tutorial

Faraday's Law of Electromagnetic Induction states that the voltage induced in any coil of wire by a varying magnetic field is proportional to the number of turns in that coil as well as the rate at which the magnetic flux varies. When a single coil of wire is wrapped around an iron core and energized with AC, the voltage across that coil is directly related to this rate-of-change of the alternating magnetism in the core:

$$V = N \frac{d\Phi}{dt}$$

Where,

V = Voltage applied to the coil or induced by the coil (Volts)

N = Number of turns of wire

$\frac{d\Phi}{dt}$ = Rate of change of magnetic flux (Webers per second)

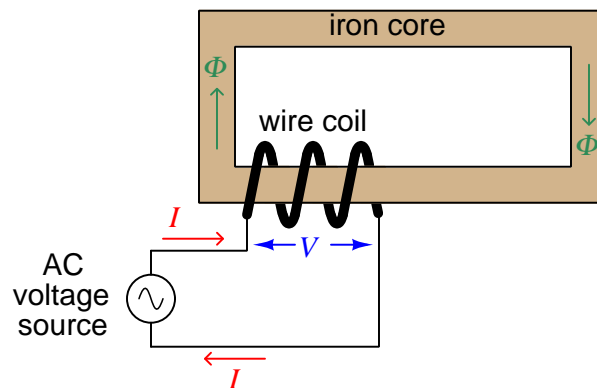

For any single wire coil, this is called *self-induction*: voltage induced in the coil as a result of the magnetic field produced¹ by the coil's own current.

A second wire coil wrapped around the same iron core experiences the same magnetic flux as the first coil, and therefore experiences an induced voltage as well. The following illustration shows a two-coil system with the second coil connected to a resistance, with current directions and voltage polarities labeled at a particular instant in time:

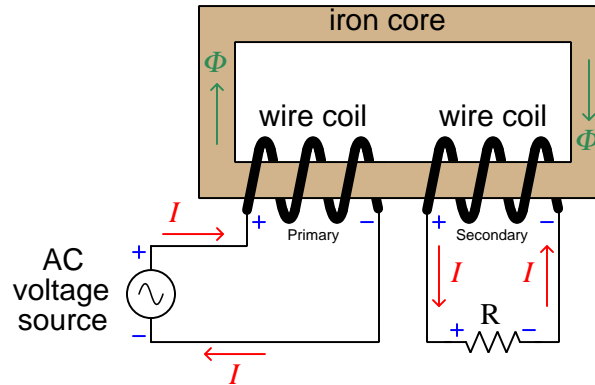

Carefully note the current arrows and voltage polarity (+ and -) symbols for the AC source, for each coil, and for the resistor. From these we can see that the AC source is indeed behaving as a *source*² and the resistor as a *load*³. The two coils have opposing roles: the coil connected to the AC source functions as a load, while the coil connected to the resistor functions as a source.

What we see happening in this illustration is a transfer of energy, from the AC source to the first coil, from the first coil to the magnetic field, from the magnetic field to the second coil, and finally from the second coil to the resistor. The Law of Energy Conservation states that energy cannot be created or destroyed, but that it can change forms, and this is what is happening here. In honor of this we call such a two-coil component a *transformer*, transforming energy from electrical to magnetic and back to electrical.

Faraday's Law tells us magnetic flux must vary in strength over time in order to induce a voltage, and so transformers require a time-varying current through their primary windings in order to function. This is why *transformers are only useful in AC or pulsed DC applications*.

¹The intensity of the magnetic flux (Φ) is a direct function of coil current, and is relatively linear. Nonlinearities are chiefly due to the ferromagnetic core material, some materials being less linear than others.

²Charge carriers entering the lower-potential (-) terminal and exiting the higher-potential (+) terminal because they have acquired some energy passing through the source.

³Charge carriers entering the higher-potential (+) terminal and exiting the lower-potential (-) terminal because they have released some of their energy passing through the load.

Transformers are typically drawn as a set of coils (commonly called *windings*) sharing a common core. The coil connected to an electrical source is called the *primary* winding, while the coil connected to an electrical load is called the *secondary* winding. If the core is ferromagnetic, it is shown as a set of parallel lines between the coils:

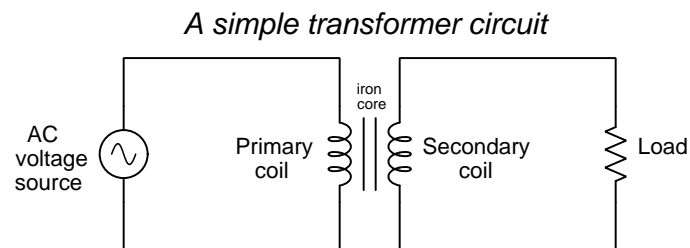

The following pair of photographs show two small transformers: the left-hand image shows a transformer intended for use in a computer power supply with the two coils (colored red, with 15 turns each) clearly visible around a green-colored toroidal core; the right-hand image shows a slightly larger transformer with a different core configuration and multiple coils:

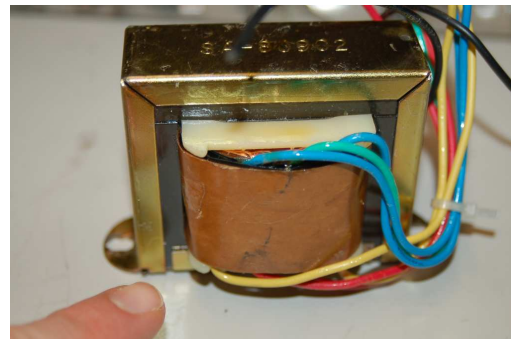
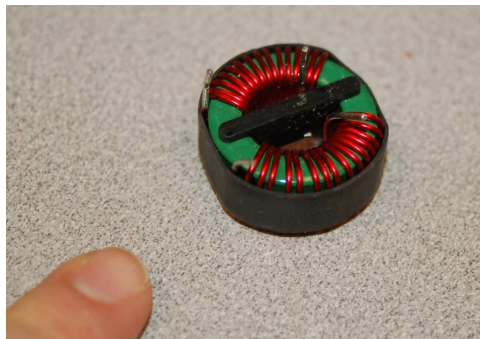

Even the largest transformers used in electric power systems operate on the same fundamental principle, and share very similar designs: a set of wire coils wrapped around a shared core material experiencing a common magnetic flux. This core is commonly comprised of laminated sheets of high-silicon alloy steel, the purpose of the laminations⁴ being to minimize induced electric currents in the core material.

⁴Laminated iron is where the core's thickness is comprised of multiple layers of thin iron sheet, each sheet electrically insulated with a thin coating to prevent sheet-to-sheet electrical conductivity. Just as the windings wrapped around the iron core experience induced voltage across their circumferential length, a solid iron core would experience circular currents within its bulk if not for the impediment posed by the laminations. These insulated laminations make the iron core electrically insulating across its width while diminishing none of its magnetic properties.

If a transformer is constructed with windings having different numbers of turns, the amount of voltage induced in the secondary will not be the same as the voltage impressed across the primary. This follows Faraday's Law: if both windings share the same magnetic flux by virtue of being wrapped around the same core, but they have differing numbers of turns (N), their voltages must differ proportionally. We may express this as a ratio of voltages and a ratio of turns:

$$\frac{V_P}{V_S} = \frac{N_P}{N_S}$$

This is perhaps the most useful property of electrical transformers: the ability to increase or decrease AC voltage simply by building coils with different numbers of turns.

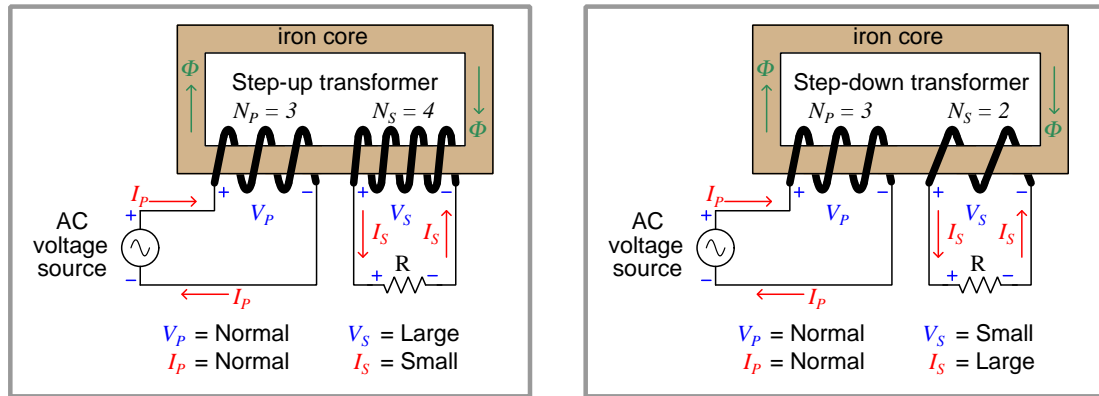

The efficient transmission and distribution of electric power was made possible by the invention of the transformer. Step-up transformers boost the voltage produced by AC generators to very high levels so that transmission line currents will be small and therefore permit the use of small-diameter (i.e. less expensive) metal wires. At locations closer to customers (loads) we use step-down transformers to decrease voltage down to safer levels with corresponding increases in current. An illustration from the year 1895⁵ shows an example of a Westinghouse power system utilizing step-up and step-down transformers:

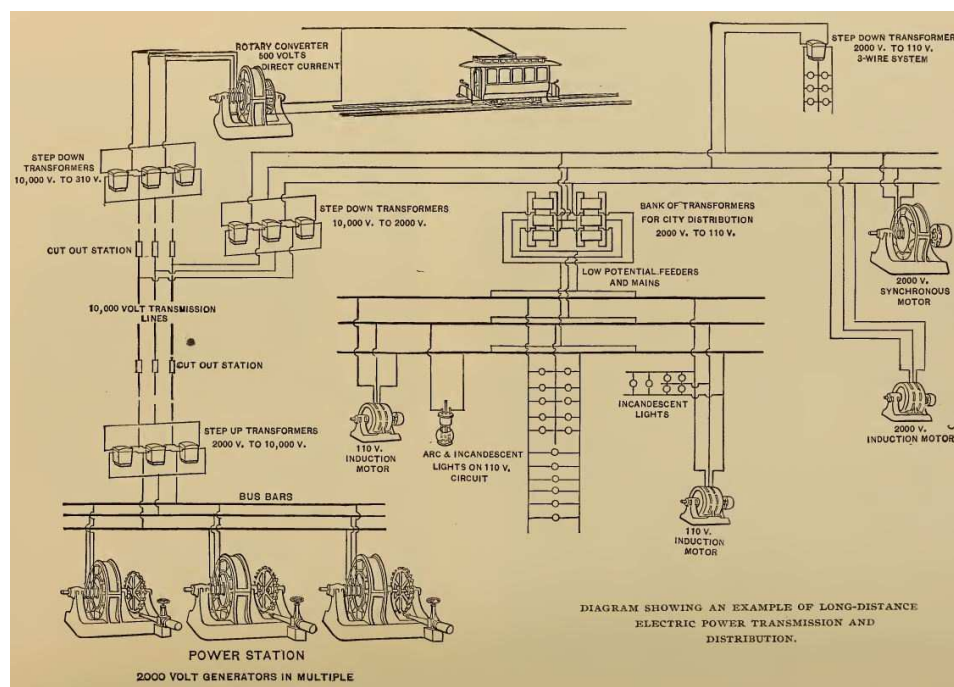

A feature of this early electrical power “grid” is that it uses *polyphase* AC, where each generator outputs multiple voltages using more than two wires. Specifically, this is a *three-phase* electrical system where each generator has three wires with three different phase-shifted voltages appearing between pairs of those wires⁶. This also explains the use of three transformers for most of the step-up and step-down stations. However, an introduction to the subject of polyphase circuits is well beyond the scope of this tutorial, so know that the basic principle of step-up and step-down transformation is just as valid for simpler (“single-phase”) AC circuits.

⁵The source for this historical illustration is *Cassier's Magazine*, which was an engineering periodical published in the late 1800's and early 1900's out of London, England. The Smithsonian Institute maintains online archives of *Cassier's* spanning many years, and it is a treasure-trove for those interested in the history of mechanical, electrical, chemical, and civil engineering.

⁶Supposing we label the three wires A, B, and C, we would measure 2000 Volts between A and B, 2000 Volts between B and C, and 2000 Volts between C and A. Each of these voltages would be phase-shifted from one another by 120° , being produced by coils of wire located at different positions around the circumference of the generator itself.

Whichever way a transformer steps voltage from primary to secondary, it must step current the other way in order that power out be equal to power in. Here are some quantitative examples, assuming perfect (100% efficient) transformers:

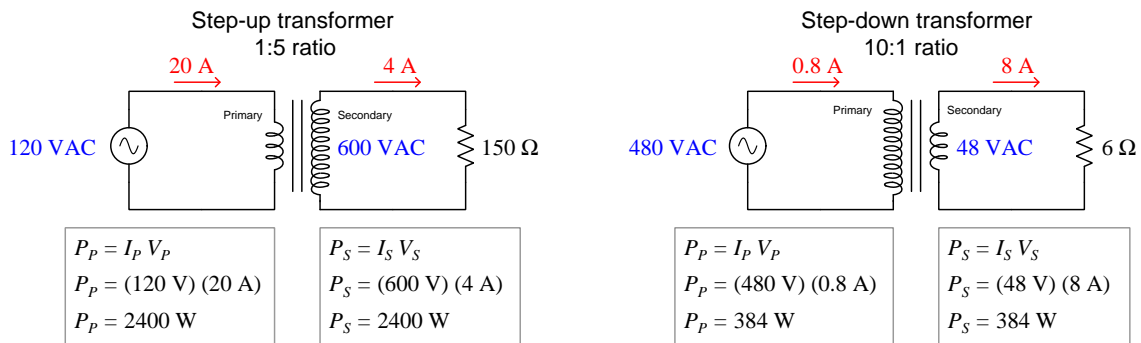

The Law of Energy Conservation explains why power in and power out must be equal for any ideal transformer. Since power is energy transfer per unit time, and we are dealing here with applications of *continuous* power transfer (i.e. constant AC voltage and current magnitudes), $P_{in} = P_{out}$ is really the same thing as energy in = energy out. Since energy *must* be conserved, any amount of continuous power entering a transformer must be balanced by that same amount of power continuously exiting. In a lossless transformer, all power input to the transformer's primary winding exits as electrical power at the secondary winding; in a real transformer, most of the input power exits as electrical power out while a small percentage exits as heat.

An interesting variation on this theme is to insert connection points mid-way in a transformer winding (called "taps") and use different portions of that one winding as primary and secondary. This arrangement is called an *autotransformer*. Autotransformers lack the electrical isolation between primary and secondary circuits enjoyed by dual-winding transformers, but they are less expensive to manufacture owing to the use of less wire:

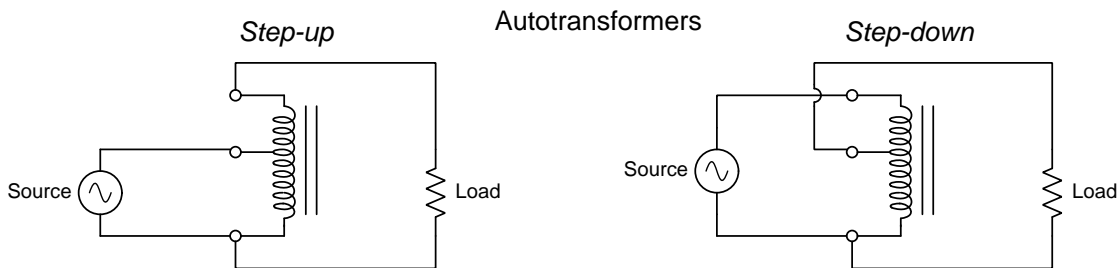

Voltage ratios follow turns ratios for autotransformers just as they do for dual-winding transformers, and of course current ratios are inverse in accordance with the Law of Energy Conservation.

Electrical power transformers, like all other electrical components, are limited in terms of voltage, current, and power. The maximum amount of voltage that any transformer winding may bear is limited by the dielectric strength of the winding's insulation as well as the core's capacity to handle magnetic flux. Too much applied voltage may damage winding insulation and/or saturate the magnetic core, the latter effect resulting in overheating. Current is limited by the resistance of the wire windings, and the transformer's ability to shed heat generated by I^2R losses. Together, these maximum voltage and maximum current limitations impose a maximum apparent power (i.e. Volts multiplied by Amperes) limit for any transformer. Power transformers are usually rated in kiloVolt-Amperes (kVA) or megaVolt-Amperes (MVA) because the VA is a fairly small unit of measurement.

Interestingly, a transformer may be operated in "reverse" mode (i.e. using the primary winding as the secondary and vice-versa) quite successfully provided that none of the ratings are exceeded. This means one may utilize a step-up transformer as a step-down transformer, and a step-down transformer as a step-up transformer, so long as *all* ratings are respected. This includes the voltage and current ratings for each individual winding in the transformer, as well as its total power rating.

The fact that transformers are imperfect means, among other things, that they restrict to some degree the amount of power flowing through them from source to load. For a well-designed and conservatively rated power transformer, this restriction (called *impedance*) may be small enough to ignore. However, for *fault* (i.e. short-circuited) conditions where the load draws much more current than usual through the secondary winding, the amount of impedance offered by a power transformer becomes an important factor in limiting the damage done by that fault.

It is common in the electrical industry to rate a power transformer's impedance in terms of *percent* rather than in *Ohms* as we might typically consider impedance, with 0% representing the ideal (lossless) transformer capable of conveying unlimited power. Two practical applications of a transformer's impedance percentage value include the following:

1. Calculating the maximum amount of current the transformer can deliver to a short-circuit load, equal to the transformer's full-load secondary current rating divided by the impedance percentage. $Z\% = \frac{I_{full-load}}{I_{short-circuit}} \times 100\%$
2. Calculating the amount of voltage "sag" at the secondary terminals between no-load and full-load conditions, equal to the full-load secondary voltage multiplied by the impedance percentage. $Z\% = \frac{V_{no-load} - V_{full-load}}{V_{full-load}} \times 100\%$

For example, a power transformer with a secondary current rating of 50 Amperes and an impedance of 6.5% is capable of delivering 769.2 Amperes of current⁷ to a short-circuited load (i.e. the full-load current rating is 6.5% of the short-circuit fault current capacity). A power transformer rated to output 240 Volts at full load and having an impedance rating of 5% will see its output voltage rise by 12 Volts when unloaded (i.e. the secondary voltage will rise to 252 Volts).

⁷This very high current value represents the absolute peak limited only by the transformer's impedance. If this current is sustained, the transformer will very quickly be damaged by overheating!

Although electric power transmission was the first application for transformers and the reason for their invention, this is not their only purpose anymore. Transformers are now used for a variety of purposes other than electric power, some of which are listed here:

- **Signal coupling** – transformers may be used to “couple” small AC signals from one portion of an electronic circuit to another without the need for direct wire connections between those circuit portions.
- **Common-mode voltage isolation** – “common-mode” voltage⁸ is any voltage present between a conductor and ground (Earth potential) that is also shared by other conductor(s). Since the primary and secondary windings of a transformer are electrically isolated from each other, it is possible for one winding to operate at some common-mode voltage while the other operates at or near ground potential. This is useful when either power or signals must be exchanged between two different circuits operating at different common-mode voltages.
- **Impedance matching** – step-up and step-down ratios have the effect of making the driving source “think” it is powering a load with a different resistance (or impedance) than it really is, and this principle may be exploited in order to best match a given AC source with a given AC load that would otherwise be mismatched if connected directly together.
- **Position sensing** – if a pair of secondary windings are connected in series-opposing polarity with each other, their combined output voltage will be zero when each winding receives the same magnetic flux from an AC-energized primary winding. If the ferromagnetic core is made to be movable, such that motion in one direction favors magnetic coupling with one secondary winding over the other, the output voltage will be proportional in magnitude to core position. This is the basis for an *LVDT* (Linear Variable Differential Transformer) or its rotary cousin the *RVDT* (Rotary Variable Differential Transformer).
- **Measurement** – transformers with precise step ratios may be used to step down high voltages for measurement at lower potentials, and likewise for transforming high current values down to low current values, both for the purpose of being able to accurately measure those dangerous quantities at safer levels. A *potential transformer* (PT) with a 1000:1 ratio, for example, is able to transform 125 kiloVolts down to 125 Volts to be measured by an AC voltmeter with a modest voltage range. A *current transformer* (CT) with a 200:1 ratio, for example, is able to transform 600 Amperes down to 3 Amperes for measurement by a low-range AC ammeter.

⁸ *Common-mode voltage* is calculated by averaging the ground-referenced voltages among multiple points. Literally, it is the amount of voltage, measured in reference to ground, that is shared in “common” with all of those terminals.

Most CTs use a single pass of wire as their primary winding ($N_P = 1$) and use a toroidal core around which multiple turns of secondary winding are wrapped. The left-hand image shows an illustration of a typical “window” style CT with secondary winding exposed, while the right-hand image shows a photograph of a real “window” a CT through which the power conductor would be threaded:

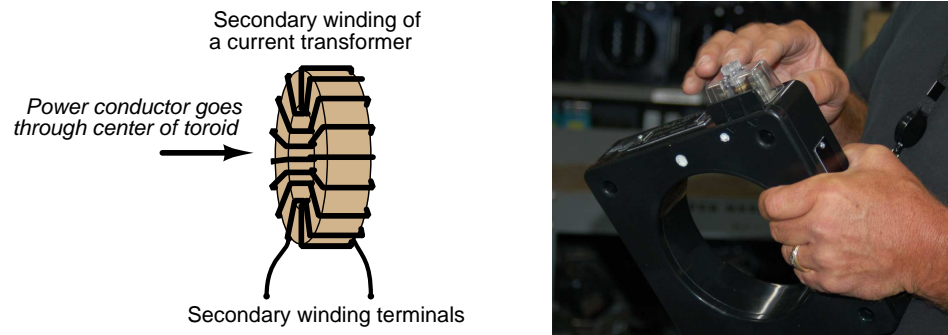

The following schematic diagram shows a typical current transformer (CT) circuit, where a CT senses current from a high-current power conductor feeding an AC load and steps that current down to a modest level (usually 5 Amperes RMS or less) where an AC ammeter may measure it. Note how the secondary circuit is grounded for safety, exploiting the electrical isolation provided by the current transformer between primary and secondary conductors:

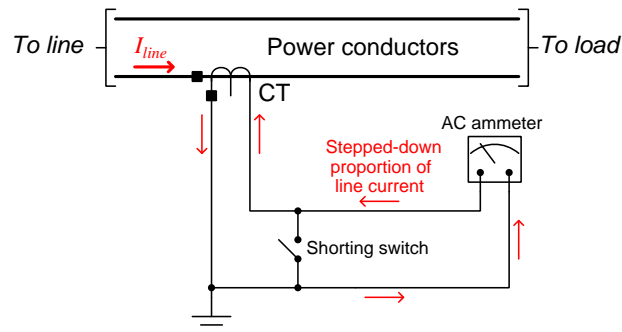

Recall that an ideal ammeter is a short-circuit, presenting no extra resistance to the measured current. This means a properly-connected CT has its secondary winding short-circuited by the ammeter. While it is never good to short-circuit the secondary winding of a power transformer fed by a voltage source, it is perfectly proper⁹ to short-circuit the secondary winding of a CT because it is essentially being powered by a current source (i.e. current is limited by the power circuit load, not by the CT and not by its ammeter).

⁹This seems very different from the behavior of most transformers, and that is because most transformers are energized by *voltage sources* rather than current sources. A voltage source is safest when open-circuited because an open-circuit prevents current while allowing a voltage to exist. A current source is safest when short-circuited because a short-circuit prevents a voltage from developing while allowing current to pass through. In either of these safe conditions, zero power is dissipated ($P = IV$) because either current is zero ($P = 0 \times V$) or voltage is zero ($P = I \times 0$) while the other quantity is finite.

Conversely, it is unsafe to *open-circuit* the secondary winding of a CT, because then it will attempt to drive current through the high resistance of the air gap, often generating extremely high voltages in a vain attempt to maintain current according to its turns ratio. This is why a *shorting switch* has been inserted in parallel with the CT's secondary winding, to allow someone to intentionally short-circuit the CT prior to removing the ammeter for maintenance or replacement during operating conditions.

Chapter 4

Full Tutorial

4.1 Basic transformer operation

Before exploring the operation of a transformer, it is useful to review the operation of a simple inductor, which is nothing more than a coil of wire usually wrapped around a ferromagnetic core material:

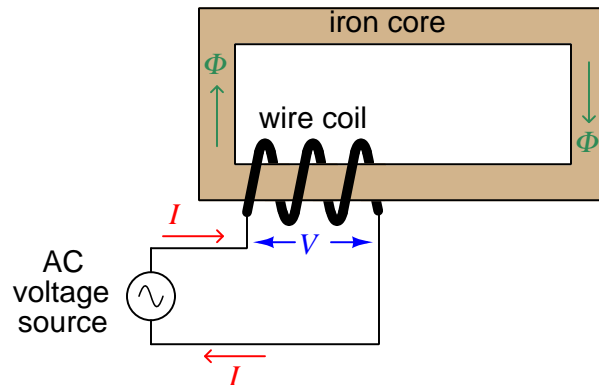

If we apply an alternating (AC) voltage to this coil, it will generate an alternating magnetic field in the core. Just how much magnetic flux (Φ) will develop in the core depends on how much voltage we apply to the coil, and the time duration we apply that voltage.

The fundamental relationship between voltage and magnetic flux for any conductive coil is given by Faraday's Law of Electromagnetic Induction¹:

$$V = N \frac{d\Phi}{dt}$$

Where,

V = Voltage applied to the coil or induced by the coil (Volts)

N = Number of turns of wire

$\frac{d\Phi}{dt}$ = Rate of change of magnetic flux (Webers per second)

If we wrap a second coil of wire around the same core as the first, it experiences an induced voltage as well because it encircles the same magnetic flux as the first coil. For the sake of analysis we will label voltage polarities at one of the peaks of the AC source:

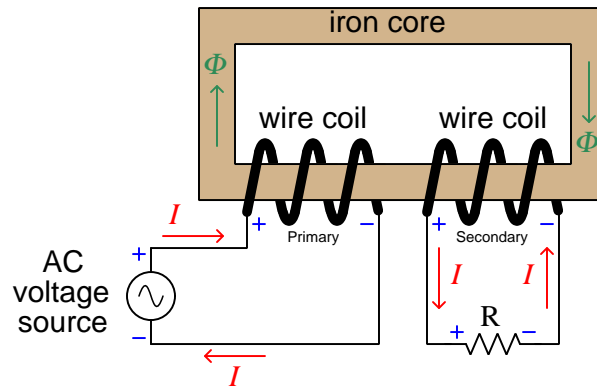

At that moment in time when the top terminal of the source is positive and the bottom terminal is negative, we see that the first coil experiences a voltage (due to self-induction), and that the second coil experiences a voltage as well (due to *mutual* induction). The polarity of both coils' voltages are identical because they are wrapped in the same direction around the core and they both experience the same magnetic flux (Φ). The magnitude of both coils' voltages are identical too, since they experience the same rate of change in magnetic flux ($\frac{d\Phi}{dt}$) and both possess the same number of turns (N). When we examine the directions of current through each coil, however, we see they are opposite one another: the left-hand coil acts as a *load* (drawing energy from the AC voltage source) while the right-hand coil acts as a *source* (providing energy to the resistive load).

¹At first it may seem strange to apply Faraday's Law here, because this formula is typically used to describe the amount of voltage *produced* by a coil of wire exposed to a changing magnetic field, not the amount of magnetic field produced by an applied voltage. However, the two are closely related because the inductor must produce a voltage drop in equilibrium with the applied voltage just like any other component, in accordance with Kirchhoff's Voltage Law. In a simple circuit such as this where the voltage source directly connects to the inductor (barring any resistive losses in the connecting wires), the coil's induced voltage drop must exactly equal the source's applied voltage at all points in time, and so Faraday's Law works just as well to describe the source's applied voltage as it does to describe the coil's induced voltage. This is the principle of *self-induction*.

What we have created here is a true *transformer*: an electromagnetic component transferring energy from electric form to magnetic form and back again to electric form. The AC voltage source is able to energize the resistive load without direct conductive connection between the two, since the magnetic flux serves as the energy “link” between the two circuits.

It is important to note that a transformer cannot function on steady (direct-current) energization because that would result in an unchanging magnetic flux, and no induction at the secondary coil. *Transformers are therefore only useful in AC or pulsed DC applications.*

Transformers are typically drawn as a set of coils (commonly called *windings*) sharing a common core. The coil connected to an electrical source is called the *primary* winding, while the coil connected to an electrical load is called the *secondary* winding. If the core is ferromagnetic, it is shown as a set of parallel lines between the coils:

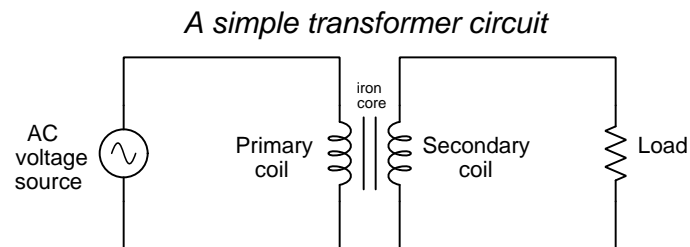

The following pair of photographs show two small transformers: the left-hand image shows a transformer intended for use in a computer power supply with the two coils (colored red, with 15 turns each) clearly visible around a green-colored toroidal core; the right-hand image shows a slightly larger transformer with a different core configuration and multiple coils:

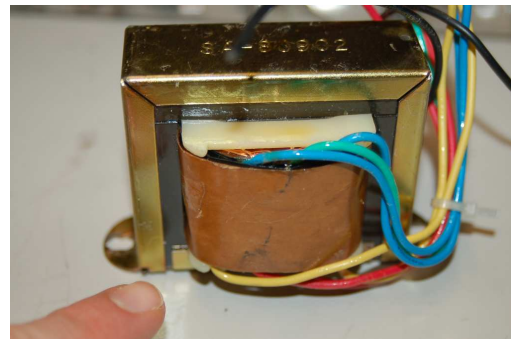
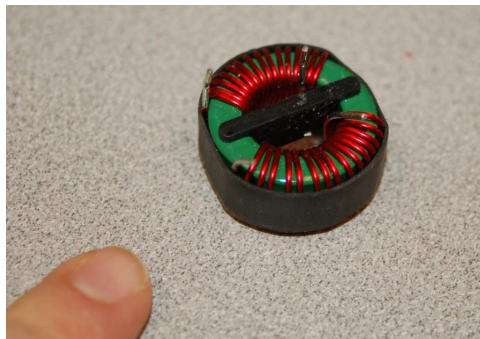

Even the largest transformers used in electric power systems operate on the same fundamental principle, and share very similar designs: a set of wire coils wrapped around a shared core material experiencing a common magnetic flux. This core is commonly comprised of laminated sheets of high-silicon alloy steel, the purpose of the laminations² being to minimize induced electric currents in the core material.

²Laminated iron is where the core's thickness is comprised of multiple layers of thin iron sheet, each sheet electrically insulated with a thin coating to prevent sheet-to-sheet electrical conductivity. Just as the windings wrapped around

4.2 Loading effects

We may explore transformer behavior by observing the effects of powering one with a constant³-voltage AC source and varying the load resistance to increase or decrease loading. Note that a “heavy” load is defined as one dissipating more power than a “light” load. In a scenario where voltage is constant, the intensity of any load is directly proportional to *current*:

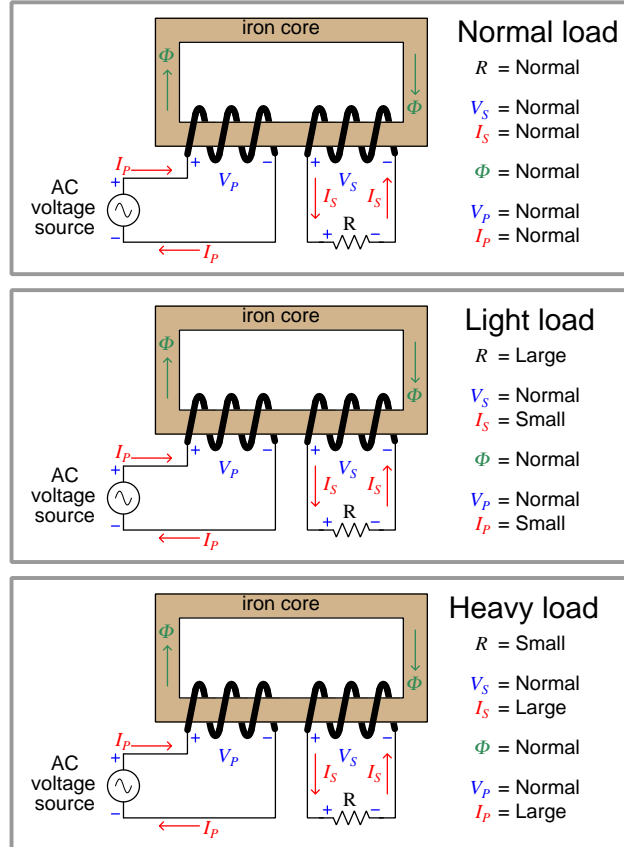

Observe how voltage at both coils is unaffected by load, and similarly how the magnetic flux remains unchanged as load varies. The secondary coil acts like a voltage source to the resistive load, reflecting the behavior of the AC voltage source powering this transformer. The magnetic flux is unaffected by secondary loading in order to satisfy Kirchhoff’s Voltage Law and Faraday’s Law at the primary coil: that coil’s voltage drop must be equal and opposite to the source’s applied voltage, and so the magnetic flux must alternate at the same rates and reach the same peaks so long as the primary source voltage does the same. Current is the only variable here, and we see how a heavier

the iron core experience induced voltage across their circumferential length, a solid iron core would experience circular currents within its bulk if not for the impediment posed by the laminations. These insulated laminations make the iron core electrically insulating across its width while diminishing none of its magnetic properties.

³In this context, “constant” means an alternating voltage with a consistent peak value, not “constant” in the sense that a DC source is constant at all points in time.

load draws more current from the secondary coil, which in turn demands more current from the source through the primary coil.

Continuing our exploration of transformer behavior, we will now power one with a constant⁴-current AC source while varying load resistance. Here, where current is constant, the intensity of any load is directly proportional to *voltage*:

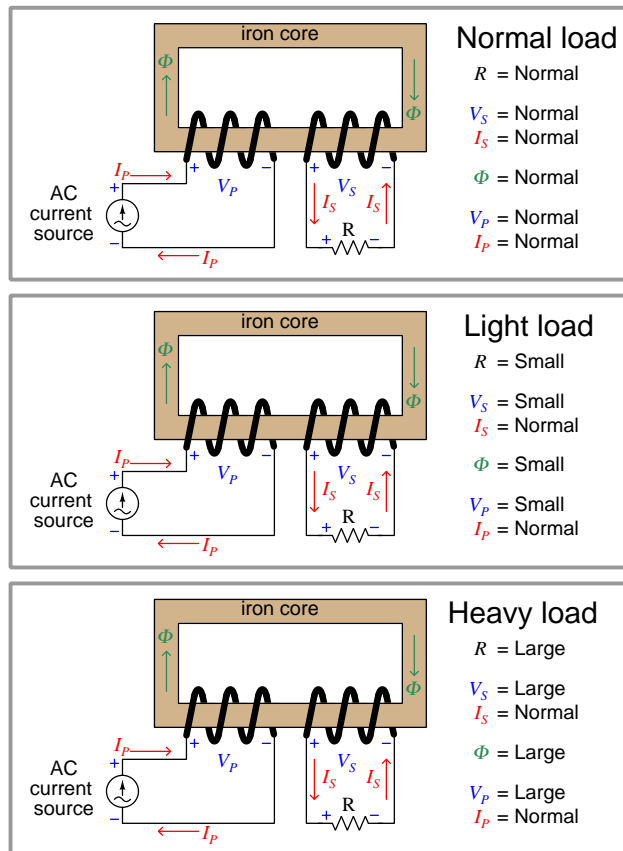

Observe how current now is the unaffected quantity, while voltage and magnetic flux are load-dependent. The secondary coil now acts like a current source to the resistive load, reflecting the behavior of the AC current source powering this transformer. As load resistance varies, the secondary coil's voltage varies proportionately, which in turn demands⁵ a commensurate change in magnetic flux.

⁴In this context, "constant" means an alternating voltage with a consistent peak value, not "constant" in the sense that a DC source is constant at all points in time.

⁵Remember Faraday's Law of Electromagnetic Induction: the amount of voltage induced in a coil is proportional to the rate-of-change of the magnetic flux passing through it over time. In order to induce more voltage across a coil with a fixed number of turns N , the rate-of-change of flux ($\frac{d\Phi}{dt}$) must increase. For any given frequency (i.e. cycle period) a greater rate of rise and fall necessitates a sinusoidal wave with a greater peak amplitude, and therefore the magnetic flux waveform must grow larger in order to induce a larger voltage at the same frequency as before.

4.3 Step ratios

Transformers are principally used to step between different levels of voltage and current. This is achieved by building the transformer with primary and secondary coils having different numbers of turns. Since both coils share the same magnetic flux, the number of turns will be proportionate to how much voltage is developed at each coil. We may prove this mathematically with Faraday's Law, using $\frac{d\Phi}{dt}$ as the quantity shared between primary and secondary coils:

$$V_P = N_P \frac{d\Phi}{dt} \qquad V_S = N_S \frac{d\Phi}{dt}$$

$$\frac{V_P}{N_P} = \frac{d\Phi}{dt} \qquad \frac{V_S}{N_S} = \frac{d\Phi}{dt}$$

According to the transitive property, if two quantities are both equal to a common third quantity, then the two quantities must be equal to each other (i.e. if $a = c$ and $b = c$ then $a = b$). Here, both the ratio of primary voltage to primary turns and the ratio of secondary voltage to secondary turns are equal to the rate of magnetic flux change, and so the two voltage/turns ratios must be equal to each other:

$$\frac{V_P}{N_P} = \frac{V_S}{N_S}$$

Rearranging the variables, we see that the ratio of primary to secondary voltage is equal to the ratio of primary to secondary turns:

$$\frac{V_P}{V_S} = \frac{N_P}{N_S}$$

This is perhaps the most useful property of electrical transformers: the ability to increase or decrease AC voltage simply by building coils with different numbers of turns.

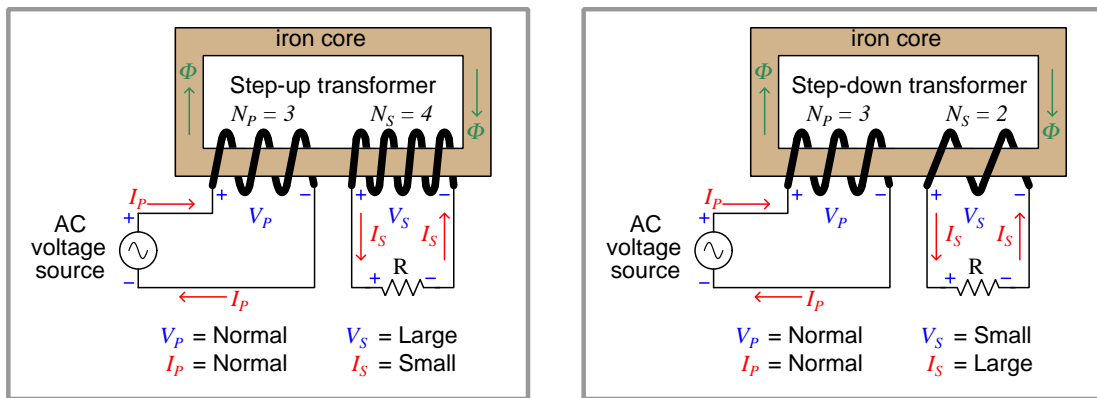

It was this property that inspired the invention of the transformer for long-distance transmission of electric power. Step-up transformers are used to boost the voltage produced by AC generators to very high levels so that the transmission line currents will be small and therefore permit the use of inexpensive, small-gauge wires. At points of use step-down transformers are used to decrease voltage down to safer levels with corresponding increases in current to power loads.

The following illustration shows a simplified schematic diagram of an AC power system dating from the year 1895⁶, showcasing an example of a Westinghouse power transmission and distribution system⁷ designed to generate power at Niagara Falls and send it some 60 miles distant:

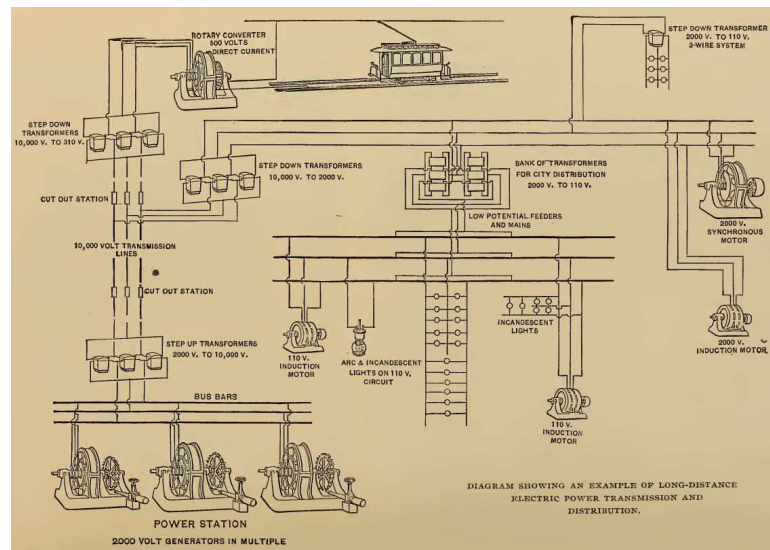

Note how the generators operate at 2000 Volts apiece, and that a bank of step-up transformers increases this to 10 kiloVolts for the 60 miles of transmission lines so that those lines operate at low current values. Sets of step-down transformers take the 10,000 Volt transmission line voltage and reduce it to any level desired. 2000 Volts is used for city distribution lines and for large industrial motors, while residential and commercial loads operate at 110 Volts. Special loads such as electric trolleys operate at their own voltage levels (310 Volts AC stepped down from 10 kiloVolts, then converted to 500 Volts DC via a motor-generator set called a “rotary converter” to directly power the trolley traction motors)⁸.

⁶The source for this historical illustration is *Cassier's Magazine*, which was an engineering periodical published in the late 1800's and early 1900's out of London, England. The Smithsonian Institute maintains online archives of *Cassier's* spanning many years, and it is a treasure-trove for those interested in the history of mechanical, electrical, chemical, and civil engineering.

⁷This particular AC power system happens to be *three-phase*, which explains why all the circuits utilize three conductors to transmit power from source to load. Polyphase AC circuits are a subject of study in a separate module, and will not be discussed here.

⁸The electric trolley system shown here is evidence of some of the technological limitations of that era. AC motor design and motor control circuitry had not yet developed to the point where efficient AC traction motor for trolley drives would be practical, and so DC motors had to be used for that purpose. Similarly, semiconductor technology was unknown at the time, and so rectification from AC to DC had to be performed by mechanically coupling an AC motor to a DC generator rather than using solid-state rectifying diodes as would be done today.

Whichever way a transformer steps voltage from primary to secondary, it must step current the other way in order that power out be equal to power in. Here are some quantitative examples, assuming lossless transformers:

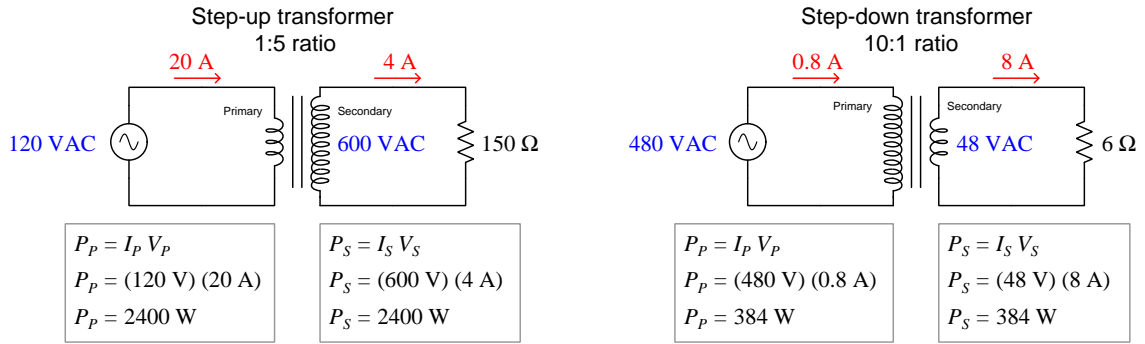

Note how primary and secondary powers are always equal to each other for any given transformer arrangement. Real transformers suffer some internal⁹ power loss, and as such will exhibit secondary power levels slightly less than primary, but assuming equality provides an easy way to check our voltage and current ratio calculations.

The equality of power out versus in for a transformer is yet another example of the Law of Energy Conservation at work. Since power is energy transfer per unit time, and we are dealing here with applications of *continuous* power transfer (i.e. constant AC voltage and current magnitudes), $P_{in} = P_{out}$ is really the same thing as energy in = energy out. Since energy *must* be conserved, any amount of continuous power entering a transformer (or any other system, for that matter) must be balanced by that same amount of power continuously exiting. In a lossless transformer, all power input to the transformer's primary winding exits as electrical power at the secondary winding; in a real transformer, most of the input power exits as electrical power out while a small percentage exits as heat.

It should be noted that transformer windings, like inductor coils, can only be made with *whole numbers* of turns. For example, it is impossible to create a coil with 3.5 turns, or 75.2 turns, or 0.8 turns, or any other fractional value. Even if you were to attempt to do so by stopping shy of one whole revolution on the last wrap of the winding when building the transformer, you would still end up with a whole number of turns once you connect that transformer winding to a source or a load. The reason for this is simple: every working transformer winding must be part of a *complete circuit* which itself is a *loop*, or *turn*. Even if much of that circuit lies some significant distance from the transformer's core, the core must still be *contained within* that circuit and therefore the circuit counts as a final (complete) turn to that winding.

⁹These power losses take the form of *core losses* due to magnetic hysteresis in the ferrous core material, and *winding losses* due to electrical resistance in the wire coils. Core losses may be minimized by reducing magnetic flux density (H), which requires a core with a larger cross-section to disperse the flux (Φ) over a wider area. Winding losses may be minimized by increasing wire gauge (i.e. thicker wire coils). In either case, these modifications make for a bulkier and more expensive transformer.

Where a range of step ratios are desired from a single transformer, it is possible to construct transformers having windings with multiple *taps*. Selecting the desired turns ratio is as simple as choosing the appropriate terminals to connect the transformer to the rest of the circuit:

"Tapped" transformer windings

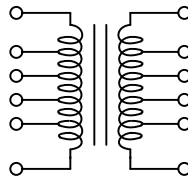

Tapped transformers are commonplace in the electric power industry, where adjustments in step ratio are occasionally necessary to compensate for the effects of system load changes over time.

A variation on this concept is to provide the secondary winding with a *wiper* much like that on a potentiometer, allowing fine adjustment of step ratio rather than discrete steps:

Variable transformer

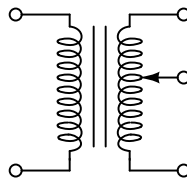

An interesting type of transformer making use of a tapped winding is the *autotransformer*. This consists of a single winding rather than separate windings, with primary and secondary connections made at different taps. Autotransformers do not provide electrical isolation between primary and secondary circuits like dual-winding transformers, but they are less expensive to construct because less wire is needed to make a single winding than to make two windings:

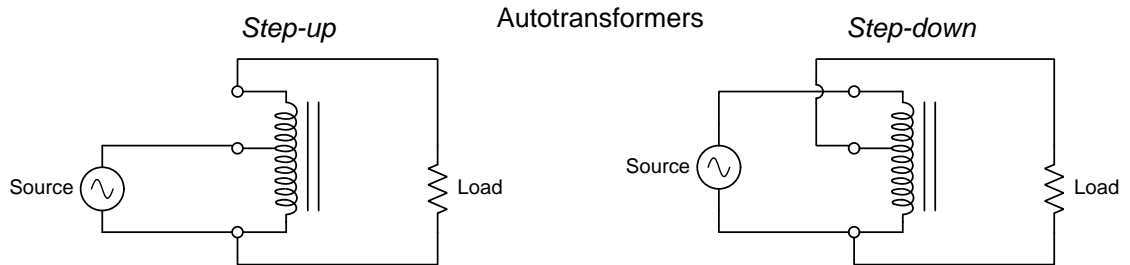

Voltage ratios follow turns ratios for autotransformers just as they do for dual-winding transformers, and of course current ratios are inverse in accordance with the Law of Energy Conservation.

4.4 Winding polarity

As seen in the previous section, the primary winding of a transformer behaves as an electrical *load* as it converts electrical energy into magnetic form while the secondary winding behaves as an electrical *source* converting that magnetic energy back into electrical energy to drive an external load. As with DC components the relationship between voltage polarity and current direction differentiates source from load:

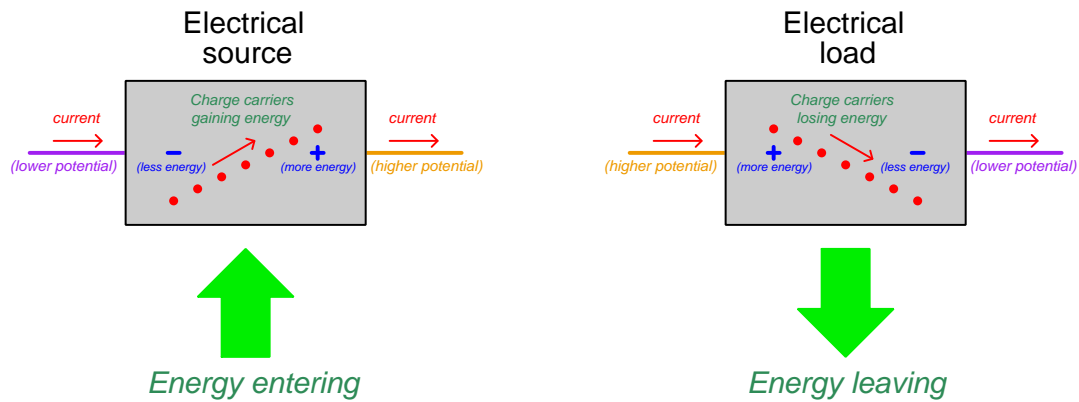

If we annotate a power transformer circuit with current arrows and voltage polarity symbols (+, -) at some moment in time when the AC waveforms are in their positive half-cycle, we see this source/load relationship clearly:

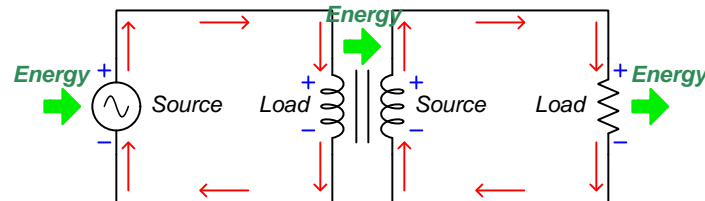

It is possible, though, to construct the transformer differently so that the secondary winding is wrapped in the opposite direction than the primary, in which case the polarities will be reversed even though the primary winding still behaves as a load and the secondary as a source:

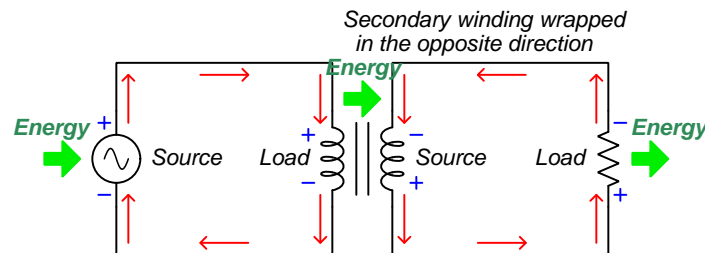

Neither + and – voltage polarity symbols nor current arrows are absolute for AC, of course, and are typically assigned arbitrarily by whoever is analyzing the circuit. They merely represent the voltage and current conditions *at a specific instant in time when the waveform is in its positive half-cycle*. However, since the previous illustrations proved it is possible to dictate the relative polarity of a transformer (i.e. the polarities between primary and secondary windings) by its construction, there needs to be some method for marking transformer terminals as to their polarity. Several methods exist to do so, and are shown in the following illustration:

Transformer polarity symbols

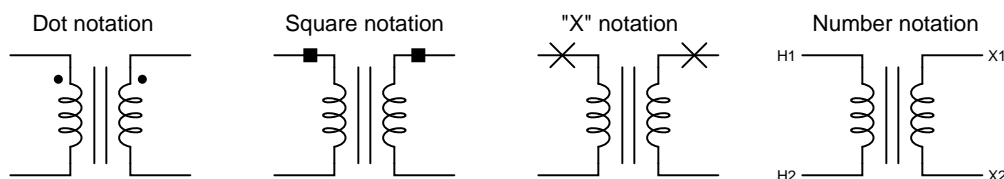

These marks should be interpreted in terms of *voltage polarity*, not current. To illustrate using a “test circuit¹⁰” feeding a momentary pulse of DC to a transformer from a small battery:

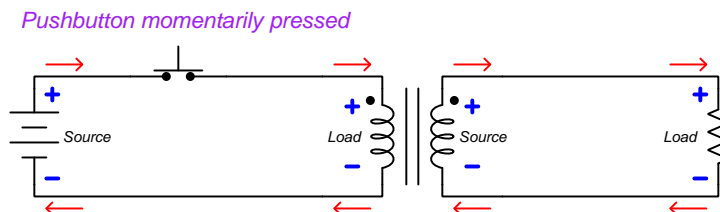

Note how the secondary winding of the transformer develops the same polarity of voltage drop as is impressed across the primary winding by the DC pulse: for both the primary and secondary windings, the sides with the dots share the same positive potential.

¹⁰The battery-and-switch test circuit shown here is not just hypothetical, but may actually be used to test the polarity of an unmarked transformer. Simply connect a DC meter to the secondary winding while pressing and releasing the pushbutton switch: the meter's polarity indicated while the button is pressed will indicate the relative phasing of the two windings. Note that the meter's polarity will reverse when the pushbutton switch is released and the magnetic field collapses in the transformer coil, so be sure to pay attention to the meter's indication *only* during the time of switch closure! This is an application where an *analog* meter may actually be superior to a digital meter, since the instantaneous movement of a mechanical needle (pointer) is easier to visually interpret than the sign of a digital number display.

If the battery were reversed and the test performed again, the side of each transformer winding with the dot would be negative:

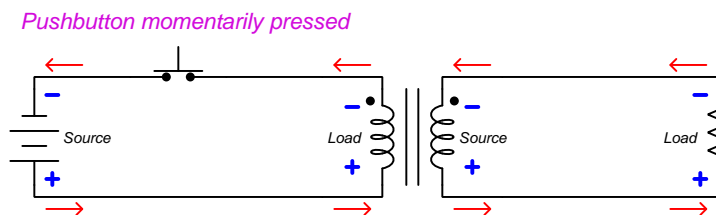

If we reverse the secondary winding's connection to the resistor and re-draw all voltages and currents, we see that the polarity dot always represents common voltage potential, regardless of source polarity:

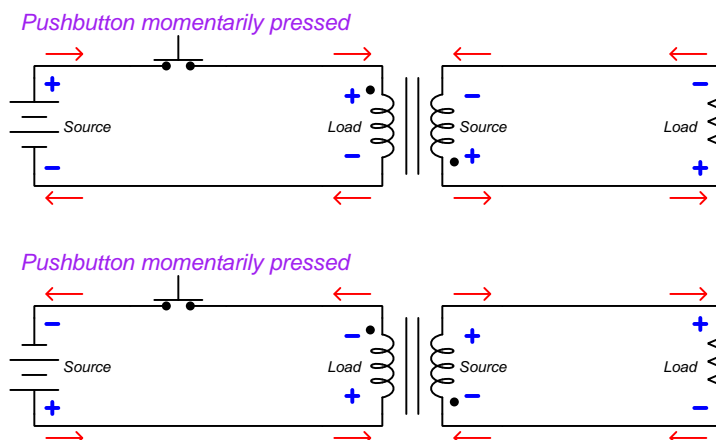

It should be noted that this battery-and-switch method of testing should employ a fairly low-voltage battery in order to avoid leaving residual magnetism in the transformer's core¹¹. A single 9-Volt dry-cell battery works well in conjunction with a sensitive ammeter¹² to sense the direction¹³ of secondary current.

¹¹The amount of magnetic force H applied to the transformer's core is a direct function of winding current. If the DC test source is capable of pushing significant amounts of current through the transformer, it may leave the core in a partially magnetized state which will then affect its performance when powered by AC. A relatively "weak" source such as a 9 Volt "transistor" battery helps ensure this will not happen as a result of the polarity test.

¹²In principle a *voltmeter* would also suffice for this test, but the low resistance of an ammeter helps ensure minimum magnetic flux accumulation in the transformer's core. This is due to the fact that induced voltage requires a build-up (or decay) of magnetic flux, and so the more voltage you demand the transformer produce for any given amount of time, the faster magnetic flux must vary, and therefore the greater amount of flux will accumulate in the core over that time. Again, the goal here is to minimize magnetic flux accumulation in the core, which can lead to transformer saturation when placed into service. Another reason to prefer an ammeter over a voltmeter, especially for a digital multimeter (DMM), is that an ammeter's low resistance will ensure there will not be enough voltage impressed upon the meter to damage it. Voltmeters with their characteristically high internal resistance may experience destructively high voltage transients as the battery source is disconnected and the magnetic field quickly collapses.

¹³Please note that the secondary winding's voltage polarity and current direction (when connected to a complete circuit) reverses as the pushbutton switch is released. Thus, when performing this test expect to see the meter reverse its sign upon switch opening compared to switch closure.

Transformers with multiple secondary windings act the same, with each secondary winding's polarity mark having the same polarity as every other winding:

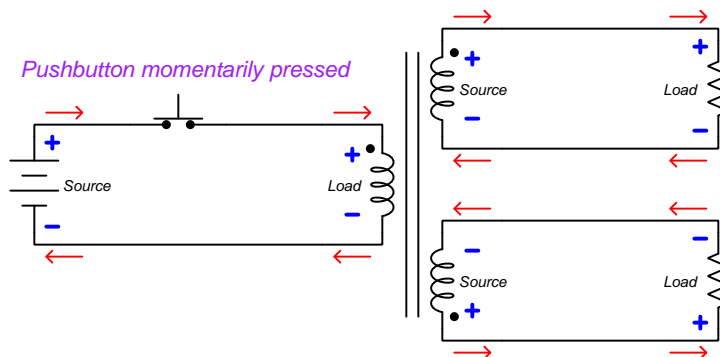

To emphasize this important point again: *transformer polarity marks always refer to voltage, never current.* The polarity of voltage across a transformer winding will always match the polarity of every other winding on that same transformer in relation to the dots. The direction of current through a transformer winding, however, depends on whether the winding in question is functioning as a *source* or a *load*. This is why currents are seen to be in opposite directions (into the dot, out of the dot) from primary to secondary in all the previous examples shown while the voltage polarities all match the dots. A transformer's primary winding functions as a *load* (conventional-flow current drawn flowing into the positive terminal) while its secondary winding functions as a *source* (conventional-flow current flowing out of the positive terminal).

Transformer polarity is very important in the electric power industry, and so terms have been coined for different polarity orientations of transformer windings. If polarity marks for primary and secondary windings lie on the same physical side of the transformer it means the primary and secondary windings are wrapped the same direction around the core, and this is called a *subtractive* transformer. If polarity marks lie on opposite physical sides of the transformer it means the primary and secondary windings are wrapped in opposite directions, and this is called an *additive* transformer. The terms “additive” and “subtractive” have more meaning when we view the effects of each configuration in a grounded AC power system. The following examples show how voltages may either add or subtract depending on the phase relationships of primary and secondary transformer windings:

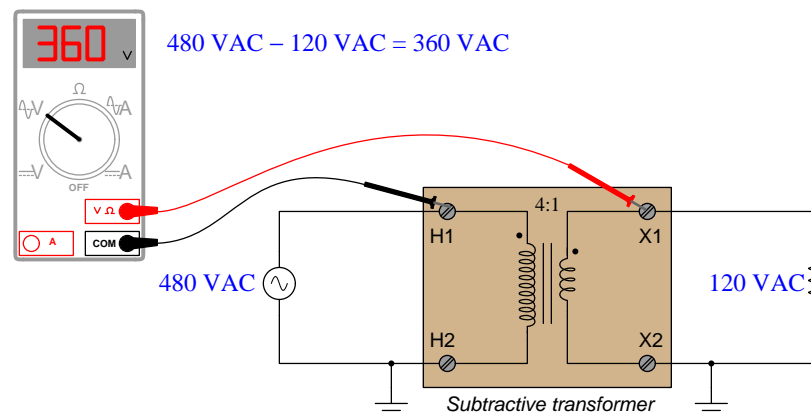
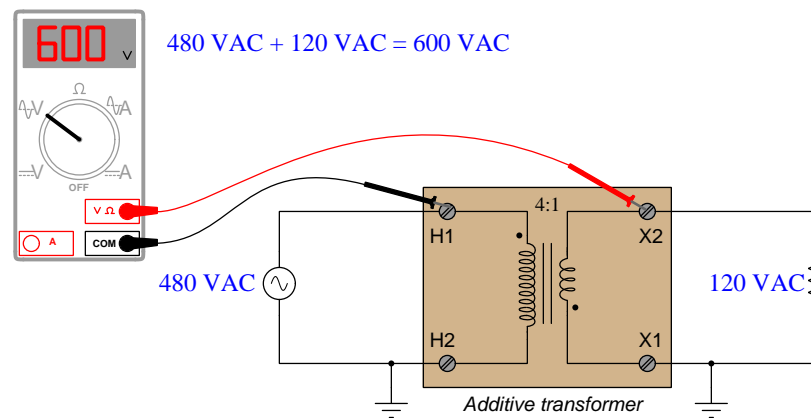

Transformers operating at high voltages are typically designed with subtractive winding¹⁴ orientations, simply to minimize the dielectric stress placing on winding insulation from inter-winding voltages.

¹⁴The IEEE standard C57.12.00-2010 (“IEEE Standard for General Requirements for Liquid-Immersed Distribution, Power, and Regulating Transformers”) states that single-phase transformers having power ratings of 200 kVA and below and high-voltage winding ratings of 8.66 kV and below must have *additive* polarity, and that all other types of power transformers must have *subtractive* polarity.

We may exploit the ability to either add or subtract the secondary voltage to/from the primary voltage if we have an application requiring a slight increase or decrease of power line voltage. We refer to this intentional auto-transformer connection of primary and secondary windings as *boost* or *buck*:

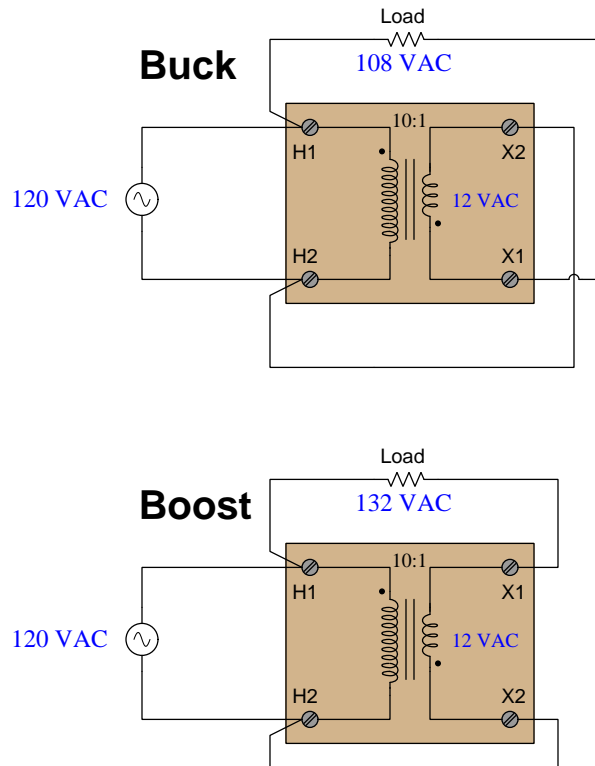

One way to more easily conceptualize the “boosting” or “bucking” behavior is to assign temporary + and – polarity markings to the the AC voltage source, then similarly mark the transformer windings with their own voltage polarity marks, and finally use Kirchhoff’s Voltage Law to determine whether the load resistance receives a greater or lesser voltage than what the source provides. In this example I leave it to the reader as an exercise to do so.

4.5 Transformer power ratings

Electrical power transformers typically bear three different types of electrical ratings, all of which must be heeded in order to ensure long service life:

- Maximum total (apparent) power
- Maximum winding current
- Maximum winding voltage (at a specified frequency)

Total power for a transformer is specified in the compound unit of *Volt-Amperes*, or *VA*. A “Volt-Ampere” is exactly as it seems: the mathematical product of Volts times Amperes. This is also known as *apparent* power, or S . True power (P) is power dissipated by a load. Reactive power (Q) is power alternately absorbed and returned by a reactance, either inductive or capacitive. Apparent power is the combination of these two, and it is what truly matters for any power transformer, because in any case it is the amount of power the transformer must *convey* in the circuit, regardless of the final destination or purpose for that power.

Transformer power ratings are usually specified in kiloVolt-Amperes (kVA) or megaVolt-Amperes (MVA) because the VA is a fairly small unit of measurement.

However, even if the power rating of a transformer is not exceeded, it is still possible to damage it by exceeding either its current or voltage ratings. The mechanism for this damage is typically excessive temperature caused by heat energy that cannot be shed quickly enough.

Excessive current is obviously destructive because this causes I^2R heating in the winding conductors, which may melt the wires in extreme cases or merely degrade the insulation by thermal breakdown in lesser cases. A transformer’s winding current rating is based on the wire gauge of the winding conductor and the effectiveness of the transformer’s cooling system.

Excessive voltage is destructive because this will cause the ferromagnetic core of the transformer to saturate with magnetic flux, and this causes heating through hysteresis losses. This saturation limit is actually a function of both voltage and frequency: at a lower frequency the voltage rating will be less because a lower frequency means a longer cycle time, which gives the rising magnetic flux longer to reach its peak value. A transformer’s winding voltage rating is based on the number of turns as well as the cross-sectional area of the iron core.

It is also possible to damage a transformer winding by excessive voltage if the applied voltage is so high that it breaks down the insulation separating the winding turns from each other and from the metal core (and frame) of the transformer. For continuous AC voltages the magnetic saturation limit is typically well below the insulation breakdown limit, but for brief transient voltages (“impulse” conditions) the insulation could fail before the core has time to saturate.

Interestingly, a transformer may be operated in “reverse” mode (i.e. using the primary winding as the secondary and vice-versa) quite successfully provided that none of the ratings are exceeded. This means one may utilize a step-up transformer as a step-down transformer, and a step-down transformer as a step-up transformer, so long as *all* ratings¹⁵ are respected.

¹⁵This includes the voltage and current ratings for each individual winding in the transformer, as well as its total power rating.

4.6 Power transformer impedance ratings

An ideal transformer is completely lossless, conveying electrical power from a connected source (on the primary side) to a connected load (on the secondary side) with 100 percent efficiency. Ideal transformers also pose no limit on the amount of power they may couple from primary to secondary winding – in other words, an ideal transformer is capable of transferring any amount of power to a load.

Real transformers, however, are not lossless and in fact do act as current-limiting devices. The mechanisms for this include magnetic hysteresis losses, wire resistance, leakage inductance¹⁶, etc.

Consider a thought experiment where we short-circuit the secondary winding of an ideal transformer, which is being powered by an AC voltage source of infinite power capacity (i.e. the source has zero impedance). How much current would pass through the shorted secondary circuit?

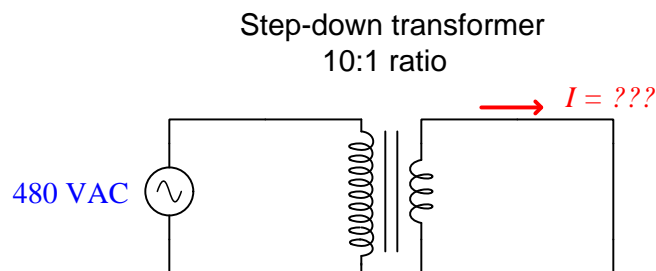

This question has no realistic answer. If the 480 VAC source has no current limitation (i.e. is capable of supplying infinite current to a shorted load) and the transformer likewise presents no limit at all to current, the shorted secondary circuit would also experience infinite current, at least in principle.

It should be rather obvious that this scenario cannot exist in the real world. Even with a source of infinite current capability, any realistic transformer would act to impede current delivered to a short-circuit on the secondary side. The question of “how much current would pass through the short-circuit” is really a question of how much *impedance* the transformer offers.

¹⁶Transformers, of course, utilize the principle of electromagnetic induction to generate a voltage at the secondary winding which may power a load. Ideally, 100 percent of the magnetic flux generated by the energized primary winding “links” or “couples” to the secondary winding. However, imperfections in the windings, core material, etc. conspire to prevent every bit of magnetic flux from coupling with the secondary winding, and so any magnetic flux from the primary winding that *doesn't* transfer power to the secondary winding simply absorbs and releases energy like a plain inductor. This is called “leakage” inductance because the flux in question has found a path to “leak” around the secondary winding. Leakage inductance may be modeled in a transformer as a separate series-connected inductance connected to the primary winding. Like any inductance, it presents a reactance equal to $X_L = 2\pi fL$, and in a transformer serves to impede primary current.

Let us consider a different thought experiment, this time using a real transformer with a short-circuited secondary winding, powered by a variable AC voltage source:

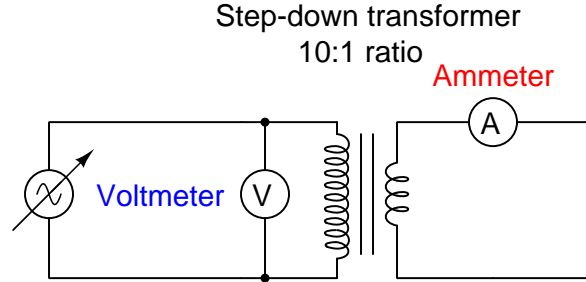

Imagine gradually increasing the source voltage until the secondary circuit ammeter registers a current equal to the transformer's full-load rating. For an ideal transformer (perfect power coupling), this would happen at some very small amount of voltage applied to the primary winding. Due to the imperfections and losses of real transformers, though, full secondary current will be obtained at a primary voltage equal to some small percentage of the normal (rated) primary voltage. Suppose, for example, our hypothetical transformer with a primary winding rating of 480 VAC outputs full secondary current through a short-circuit at an applied source voltage of only 22 Volts. 22 Volts is 4.58% of 480 Volts, and so we would say this transformer has a measured impedance of 4.58 percent¹⁷.

Although a short-circuited secondary winding scenario may seem contrived, it actually is quite relevant to real-world conditions. In electrical power systems we are often concerned with the maximum amount of current which will flow during *fault* conditions. If two power conductors directly touch each other, or if a low-resistance arc develops between them through the air, the effect is very nearly a perfect short-circuit. This means transformer impedance will be the dominant factor in limiting fault current: the more impedance a transformer has, the less fault current will occur during short-circuit conditions.

¹⁷Although it is possible to express transformer impedance in the more familiar unit of *Ohms* (Ω), percentage is greatly preferred for the simple reason that it applies identically to the primary and secondary sides of the transformer. Expressing transformer impedance in Ohms would require a different value depending on whether the primary side or secondary side were being considered.

One way to apply the impedance percentage value for a power transformer to a fault scenario is to use it as a multiplying factor for secondary current. For example, if a power transformer has a maximum rated secondary current of 180 Amperes and an impedance rating of 3.3%, the available secondary current into a bolted¹⁸ fault will be:

$$\frac{180 \text{ A}}{3.3\%} = 5454.5 \text{ A}$$

Expressed as a general formula, a power transformer's impedance is the ratio between full-load secondary current and short-circuited secondary current:

$$Z_{\%} = \frac{I_{full-load}}{I_{short-circuit}} \times 100\%$$

Bolted-fault current calculations are very useful when predicting the amount of energy released in an *arc blast* incident, which is what happens when an electric arc develops between two closely-spaced conductors in a high-power electric power system. The arc behaves as an extremely low-resistance connection between the conductors, resulting in very large current values with correspondingly high arc temperatures.

Another way to apply impedance percentage to power transformers is to use it as a factor in calculating how far the output voltage of a power transformer will “sag” below its ideal value when energizing a load. Suppose we had a power transformer with a precise 5:1 turns ratio, designed to receive 120 VAC at its primary winding and output exactly 24 VAC. Under no-load conditions the transformer's internal impedance will be of no effect, and the transformer will output 24 VAC exactly. However, when a load is connected to the secondary terminals and current begins to flow to power this load, the transformer's internal impedance will result in the secondary voltage decreasing by a small amount. For example, if this transformer happens to have an impedance of 5.5%, it means the secondary (output) voltage will sag 5.5% below 24 VAC at full load, assuming the primary voltage is maintained at the standard 120 VAC level. 5.5% of 24 Volts is 1.32 Volts, and so this transformer's secondary voltage will “sag” from 24 Volts down to 22.68 Volts (i.e. 1.32 Volts less than 24 Volts) as load current increases from zero to its full rated value.

Expressed as a general formula, a power transformer's impedance is the ratio between the difference of no-load and full-load secondary voltages versus full-load secondary voltage. This is also known as the transformer's *voltage regulation*:

$$Z_{\%} = \text{Regulation } \% = \frac{V_{no-load} - V_{full-load}}{V_{full-load}} \times 100\%$$

For this reason, power transformers are typically constructed with turns ratios providing slightly greater secondary (output) voltage than ideal, in order to provide the rated output voltage when operating under load. For example, a typical 120 VAC primary power transformer with a “24 Volt” secondary voltage rating will be designed with a step-down turns ratio slightly *less* than 5:1 so that it actually outputs more than 24 Volts when unloaded, so that when it is fully loaded the output voltage will “sag” to 24 Volts.

¹⁸The rather colorful term “bolted” refers to a short-circuit fault consisting of a large copper bus-bar physically attached to the transformer's secondary terminal using bolts. In other words, a “bolted” fault is as close to a perfect short-circuit as you can get.

4.7 Impedance transformation

Now we will turn our attention to another way in which transformers relate to impedance, but this time instead of quantifying the impedance intrinsic to a particular transformer as a percentage figure, we will investigate how an ideal transformer makes the impedance of a load “look” different from the perspective of the source. To illustrate, we will consider a very simple step-down power transformer circuit, with rounded numerical values to make the calculations as easy as possible:

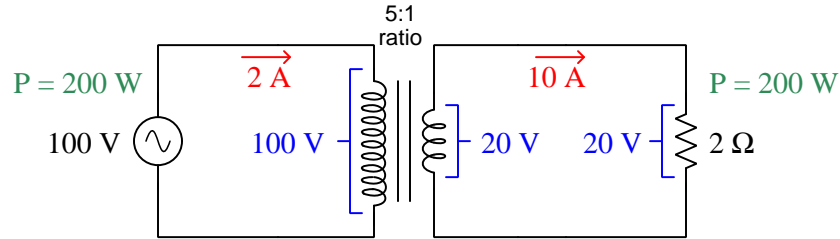

Here, a step-down transformer with a 5:1 turns ratio steps 100 Volts AC down to 20 Volts AC to power a 2 Ohm load. Ohm’s Law dictates 10 Amperes of current given 20 Volts across a 2 Ohm load, and the 5:1 turns ratio of the transformer steps this current down to 2 Amperes on the primary side. The end-result is the source experiencing 2 Amperes of current (at 100 Volts) which the load experiences 10 Amperes of current (at 20 Volts), in either case a power of 200 Watts. Continuous power should be precisely equal in the primary and secondary circuits of an ideal (i.e. non-dissipative) transformer owing to the Law of Energy Conservation. For real transformers having less-than-perfect energy efficiency, secondary-circuit power will always be slightly less than primary-circuit power, but for these calculations we will assume perfect energy-conversion efficiency in order to simplify our calculations and allow us to more easily focus on the topic at hand.

Now let us consider what the 2 Ohm load “looks like” from the perspective of the 100 Volt source. The source experiences a current of 2 Amperes, which is the equivalent of directly powering a 50 Ohm load ($\frac{100 \text{ V}}{2 \Omega}$) with no transformer:

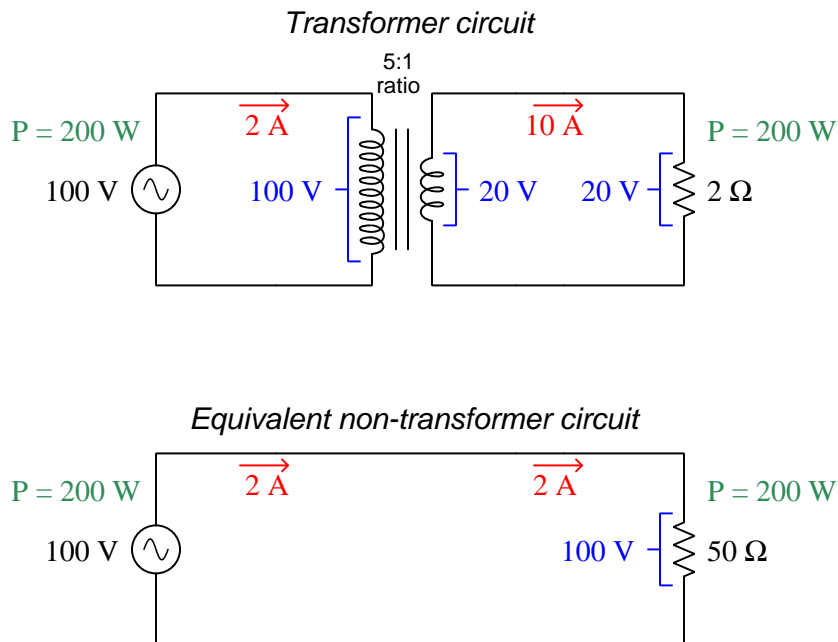

From this simple example we may conclude that the 5:1 ratio transformer *makes it appear as though the load resistance is 25 times larger than it actually is* from the perspective of the source.

This property of transformers is very useful in many applications, especially in electronic amplifier circuits for AC signals. Amplifiers work best when powering loads having a limited range of impedance, and if a mis-match exists between such an amplifier and an AC load a transformer placed between the two with the right turns ratio can make them a better match for each other.

Impedance transformation ratio for any transformer is the *square* of its turns ratio, which agrees with the previous example (a 5:1 turns ratio resulting in a 25:1 impedance ratio):

$$\frac{Z_P}{Z_S} = \left(\frac{N_P}{N_S} \right)^2$$

Another interesting property of impedance transformation is that an ideal transformer presents a proportionate load impedance to the source, but with the exact same resistance/reactance properties. For example, if the load is purely resistive then the source will see a purely resistive load, only having a proportionately larger or smaller *magnitude*; if the load is inductive then the source will also see the same inductive phase angle; if the load is capacitive the source will likewise experience the same capacitive phase angle.

4.8 Transformer applications

Power transformers are manufactured in a wide range of sizes and designs, from small to huge. The following photograph shows a 2:1 step-down transformer designed to step 500 kiloVolts down to 250 kiloVolts as part of an electric power substation, standing over 7 meters in total height. Like most transformers of this class, it is oil-cooled to dissipate heat; a bank of air fans seen on its left-hand side blow cooling air past a radiator assembly through which the oil circulates:



Although electric power transmission was the first application for transformers and the reason for their invention, this is not their only purpose anymore. Transformers are now used for a variety of purposes other than electric power, some of which are listed here:

- **Signal coupling** – transformers may be used to “couple” small AC signals from one portion of an electronic circuit to another without the need for direct wire connections between those circuit portions.
- **Common-mode voltage isolation** – “common-mode” voltage¹⁹ is any voltage present between a conductor and ground (Earth potential) that is also shared by other conductor(s). Since the primary and secondary windings of a transformer are electrically isolated from each other, it is possible for one winding to operate at some common-mode voltage while the other operates at or near ground potential. This is useful when either power or signals must be exchanged between two different circuits operating at different common-mode voltages.
- **Impedance matching** – step-up and step-down ratios have the effect of making the driving source “think” it is powering a load with a different resistance (or impedance) than it really

¹⁹ *Common-mode voltage* is calculated by averaging the ground-referenced voltages among multiple points. Literally, it is the amount of voltage, measured in reference to ground, that is shared in “common” with all of those terminals.

is, and this principle may be exploited in order to best match a given AC source with a given AC load that would otherwise be mismatched if connected directly together.

- **Position sensing** – if a pair of secondary windings are connected in series-opposing polarity with each other, their combined output voltage will be zero when each winding receives the same magnetic flux from an AC-energized primary winding. If the ferromagnetic core is made to be movable, such that motion in one direction favors magnetic coupling with one secondary winding over the other, the output voltage will be proportional in magnitude to core position. This is the basis for an *LVDT* (Linear Variable Differential Transformer) or its rotary cousin the *RVDT* (Rotary Variable Differential Transformer).
- **Measurement** – transformers with precise step ratios may be used to step down high voltages for measurement at lower potentials, and likewise for transforming high current values down to low current values, both for the purpose of being able to accurately measure those dangerous quantities at safer levels. A *potential transformer* (PT) with a 1000:1 ratio, for example, is able to transform 125 kiloVolts down to 125 Volts to be measured by an AC voltmeter with a modest voltage range. A *current transformer* (CT) with a 200:1 ratio, for example, is able to transform 600 Amperes down to 3 Amperes for measurement by a low-range AC ammeter.

Current transformers, or *CTs* as they are commonly referred to, differ significantly in appearance from other transformer types. Most *CTs* use a single pass of wire as their primary winding ($N_P = 1$) and use a toroidal core around which multiple turns of secondary winding are wrapped. The left-hand image shows an illustration of a typical “window” style *CT* with secondary winding exposed, while the right-hand image shows a photograph of a real “window” *CT* through which the power conductor would be threaded:

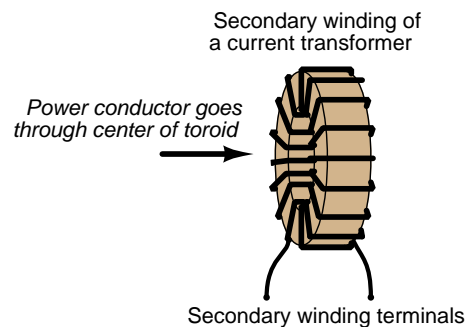

In addition to their appearance being different from most transformers, CTs are also used in a very different manner from most transformers. Like all transformers, the secondary reflects the characteristics of any electrical source feeding the primary, and since the purpose of a CT is to transform a high *current* value from a power circuit into a lower current value used in a metering circuit, the secondary winding tends to behave as a *current source*. This means CT secondary windings are safest when *short-circuited* through either a low-resistance AC ammeter or connected directly to each other by a jumper wire or by a *shorting* switch in the closed position, because a short-circuit is a negligible load for a current source.

The following schematic diagram shows a typical CT circuit, where a CT senses current from a high-current power conductor feeding an AC load and steps that current down to a modest level (usually 5 Amperes RMS or less) where an AC ammeter may measure it. Note how the secondary circuit is grounded for safety, exploiting the electrical isolation provided by the current transformer between primary and secondary conductors:

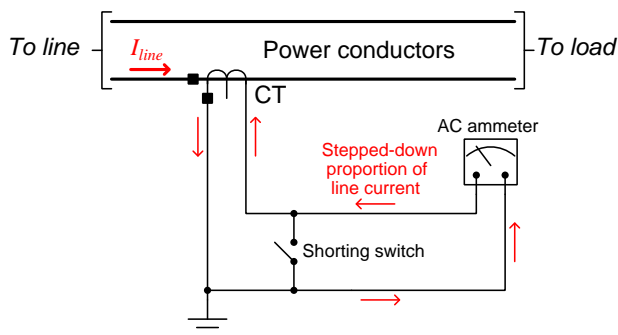

An open-circuited CT secondary winding is a very dangerous thing, as any current passing through the power conductor attempts to drive a proportionate current out of the CT's secondary winding through the air gap that separates the secondary conductors. The CT's turns ratio (secondary having multiple turns, primary only being 1 turn) is able to generate dangerous levels of secondary voltage as it attempts to push an AC current through air.

This seems very different from the behavior of most transformers, and that is because most transformers are energized by *voltage sources* rather than current sources. A voltage source is safest when open-circuited because an open-circuit prevents current while allowing a voltage to exist. A current source is safest when short-circuited because a short-circuit prevents a voltage from developing while allowing current to pass through. In either of these safe conditions, zero power is dissipated ($P = IV$) because either current is zero ($P = 0 \times V$) or voltage is zero ($P = I \times 0$) while the other quantity is finite.

4.9 Transformer construction

All transformers consist of wire turns wrapped around some form of core, the core material usually being ferromagnetic in nature (e.g. iron or steel or ferrite). However, multiple ways exist to do this, each with its own advantages and disadvantages.

Below we see a voltage step-down power transformer that has been cut in half using a bandsaw, to reveal a cross-section of its iron core as well as its primary and secondary windings:

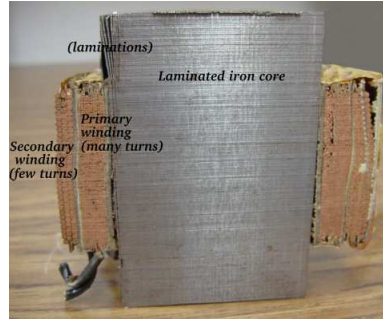

A photograph of an intact transformer with the same physical construction is shown here. The primary and secondary windings are wrapped around a plastic *bobbin* with a hollow center, and this is slipped into the iron core structure:

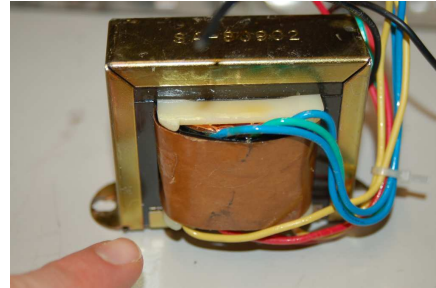
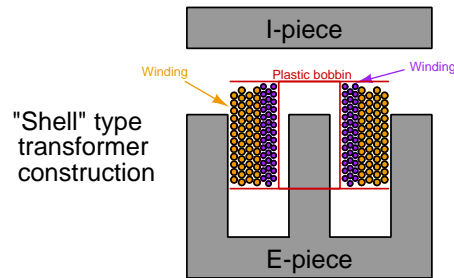

The "E" and "I" pieces typically consist of thin sheet iron or steel, many such sheets stacked together to form a laminated core. Each sheet's surface is coated in an insulating material, making the laminated core electrically conductive only within the plane of each lamination, and not across laminations. This reduces the tendency for *eddy currents* to form in the iron core during operation, those eddy currents otherwise contributing greatly to energy dissipation in the form of undesirable I^2R power losses.

This form of transformer construction is easy to manufacture. Primary and secondary windings may be machine-wound around the plastic bobbin prior to core assembly, the bobbin being slipped over the center portion of the "E" before the "I" piece is welded into place to form a complete magnetic circuit. If any air gap is desired between the "E" and "I" pieces (to limit the core's ability to magnetically saturate), this may be easily engineered by careful sizing of the individual lamination sheets, making some of them slightly longer than others such that not every "I" lamination butts up against its respective "E" lamination sheet.

Three-phase power transformers often use an E/I style of laminated core, with a primary/secondary winding bobbin slipped over each of the “E” piece’s legs. A photograph of a decommissioned three-phase power transformer appears here, where you can clearly see each of the three primary/secondary winding sets.



Another popular form of transformer construction is the *toroidal* core shape. Its prime advantage is excellent containment of its magnetic flux, with no sharp corners in the magnetic flux path. However, this type of transformer is not as easy to assemble as the E/I core type, and that tends to make it more expensive:



In some applications it is important to limit the amount of parasitic capacitance existing between primary and secondary winding turns. Transformers of the previous types have significant inter-winding capacitance because their primary and secondary windings overlay one another. A simple alternative is the so-called *split-bobbin* type where each winding has its own dedicated bobbin, these bobbins being stacked on the same magnetic core to maintain good magnetic coupling between them. In the following photograph we see a four-winding transformer with each winding on its own bobbin:



Chapter 5

Historical References

This chapter is where you will find references to historical texts and technologies related to the module's topic.

Readers may wonder why historical references might be included in any modern lesson on a subject. Why dwell on old ideas and obsolete technologies? One answer to this question is that the initial discoveries and early applications of scientific principles typically present those principles in forms that are unusually easy to grasp. Anyone who first discovers a new principle must necessarily do so from a perspective of ignorance (i.e. if you truly *discover* something yourself, it means you must have come to that discovery with no prior knowledge of it and no hints from others knowledgeable in it), and in so doing the discoverer lacks any hindsight or advantage that might have otherwise come from a more advanced perspective. Thus, discoverers are forced to think and express themselves in less-advanced terms, and this often makes their explanations more readily accessible to others who, like the discoverer, comes to this idea with no prior knowledge. Furthermore, early discoverers often faced the daunting challenge of explaining their new and complex ideas to a naturally skeptical scientific community, and this pressure incentivized clear and compelling communication. As James Clerk Maxwell eloquently stated in the Preface to his book *A Treatise on Electricity and Magnetism* written in 1873,

It is of great advantage to the student of any subject to read the original memoirs on that subject, for science is always most completely assimilated when it is in its nascent state . . . [page xi]

Furthermore, grasping the historical context of technological discoveries is important for understanding how science intersects with culture and civilization, which is ever important because new discoveries and new applications of existing discoveries will always continue to impact our lives. One will often find themselves impressed by the ingenuity of previous generations, and by the high degree of refinement to which now-obsolete technologies were once raised. There is much to learn and much inspiration to be drawn from the technological past, and to the inquisitive mind these historical references are treasures waiting to be (re)-discovered.

5.1 The first transformer

The following illustration comes from one of the cover pages of John Ambrose Fleming's text *The Alternating Current Transformer in Theory and Practice* Volume 1:

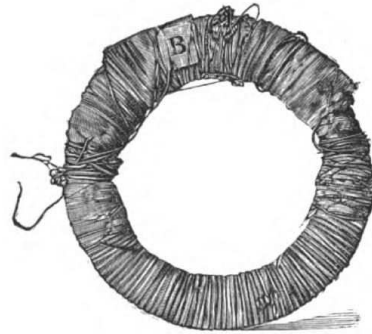

THE FIRST TRANSFORMER.

The Iron Ring, with insulated Primary and Secondary Coils wound on it, with which Faraday made the discovery of Magneto-Electric Induction. Photographed from the original, preserved in the Museum of the Royal Institution.

[*Prontiqueur.*

As you can see, this transformer was based on a toroidal (circular) iron core, around which were wrapped two sets of insulated wires, one primary and one secondary.

5.2 Prototype electrical power transmission system

A detailed description of an early prototype AC power system was presented in an article entitled “The Transmission of Power” written by Carl Hering in Volume 1 of *Cassier’s Magazine*, an engineering periodical started in 1891. In this article the author describes the function of transformers for the efficient transmission of electric power over long distances.

The first noteworthy quote describes the purpose of using high voltages for long-distance power transmission, and how the relative simplicity of AC generators (“dynamos”) over DC (“continuous current”) generators and the motionless operation of transformers made high-voltage transmission practical. Note also Hering’s use of the now-antiquated term “tension” for *voltage*:

. . . To be successful at all for long distances requires, beyond question, the use of very high potentials, as otherwise the cost of the line will make it impracticable. If continuous currents are to be used, they must be generated directly by the dynamo at that high potential, as there is no means at present known for converting a low-tension continuous current into one of high tension without the use of moving machinery ; continuous currents would therefore require that very high-tension currents be produced directly from a dynamo with a commutator. Long experience and frequent attempts have shown that it is not practicable to exceed five or six thousand volts at the very most on continuous current dynamos, and even then there are many objections.

. . . The field is therefore left tolerably clear for alternating currents, who owe it to two features, one that the alternating current dynamos require no commutator, and the other that such currents may readily be converted from a low tension to a high tension and the reverse with but a small loss of a few per cent, in each transformation. An alternating current dynamo for generating low potential currents is the simplest kind of dynamo, and a transformer requiring no moving machinery is a very simple thing to take care of, if, indeed, it required any attention at all. Simplicity alone, therefore, is very much in favor of alternating currents. [page 451]

Next, we read a detailed description of how transformers were used in this electrical system:

The plant consisted in general of a dynamo of exceedingly simple construction generating a large current, but of only 50 volts. This was led through the switchboard with all its accessory apparatus and was then transformed by a step-up transformer into a small current at 16,000 volts. This was led through bare overhead wires a distance of 108 miles, where it was again transformed back to a low voltage by step-down transformers. It should be noticed that the currents at the dynamo and the switchboard, where they had to be handled, were only 50 volt currents, thereby avoiding all possible danger to the attendant besides facilitating greatly the construction of the dynamo. [page 453]

5.3 Early transformer core construction

Early transformers were referred to as *induction coils* by their experimenters, and some interesting details on transformer core design are found in John Ambrose Fleming's text *The Alternating Current Transformer In Theory And Practice* published in 1892.

This first quote describes the discovery that the presence of an iron core in the transformer greatly increased its effectiveness over an air core:

. . . He put a solid iron core in the bobbin, and he was delighted to find that he got powerful shocks from the secondary circuit when the current from one or two cells was interrupted in the primary. [page 10]

Nineteenth-century electrical experimentation was as intrepid as it was crude, with experimenters frequently resorting to the use of their own bodies to gauge the intensity of voltage or current. Fleming's text is filled with references to "powerful shocks" from various electrical apparatus, some of the devices being built with metal handles designed for the experimenter to grasp!

In another experiment, an experimenter named Bachhoffner discovered that a bundle of iron wires functioned better than a solid iron bar in the transformer's core:

Bachhoffner observed that a bundle of fine iron wires used as a core in Sturgeon's coil gave far better shocks than when a solid iron bar was employed. We must therefore credit Bachhoffner with being the first to recognize the value of a divided iron core. [page 11]

Although Fleming's text does not give a reason for this, we now know it is due to less energy being dissipated in the core by *eddy currents*. Since iron metal is a conductor of electricity as well as a ferromagnetic material, there will be electric currents induced in the core from the excitation of the primary winding. These electric currents dissipate energy as they travel through the resistance of the iron metal, and this dissipated energy means there will be less energy available at the secondary coil to be utilized or measured, in this case by the intensity of electric shock delivered to the experimenter. The use of fine iron wires rather than a solid iron bar weakened these eddy currents, as fine iron wires would exhibit a far greater resistance to eddy currents attempting to travel laterally from wire to wire, as these wires' surfaces would undoubtedly be coated in a thin layer of insulating iron oxide. For any given rate-of-change of magnetic flux, the voltage induced in the core by the varying flux would have less opportunity to generate a current with this high resistance (I will be small when R is large, for any given V following Ohm's Law: $I = \frac{V}{R}$), and with less eddy current there will be less energy dissipated in the resistance of the core, and therefore more energy available at the secondary coil.

Modern transformers, of course, do not use bundles of iron wire for their cores. Instead, they utilize thin *sheets* of iron, each one coated in an insulating varnish, and bundled together to form a *laminated* iron structure.

Chapter 6

Derivations and Technical References

This chapter is where you will find mathematical derivations too detailed to include in the tutorial, and/or tables and other technical reference material.

6.1 Magnetic field quantities

A useful definition of magnetic field (B) is in terms of the force (F , called the *Lorentz force*) exerted on a moving electric charge (Q) influenced by that field:

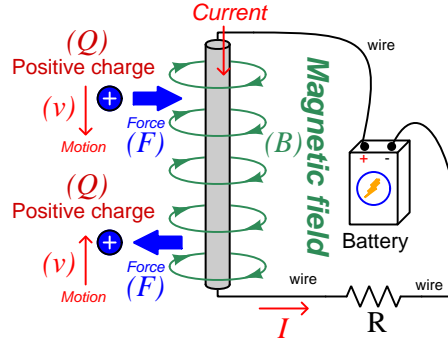

$$\vec{F} = Q\vec{v} \times \vec{B}$$

Where,

\vec{F} = Force exerted on the charge (Newtons)

Q = Charge quantity (Coulombs¹)

\vec{v} = Velocity of moving charge (meters per second)

\vec{B} = Magnetic field (Tesla, Webers per square meter, or Newtons per Ampere-meter)

The small “arrow” symbols above the variables for force and velocity and magnetic field in the equation denote those variables as *vector quantities*, having both magnitude and direction. Charge is a *scalar quantity* having only magnitude but no direction, and as a scalar quantity when multiplied by the velocity vector it simply magnifies the magnitude but does not alter the direction. The “cross-product” (\times) is a specific form of vector multiplication, and it results in a product at right angles to the vector directions of both terms. Therefore, the force and velocity and electric field vectors never all point in the same direction.

¹One Coulomb of electric charge is equal to 6.2415×10^{18} electrons.

Vector cross-products conveniently relate to the fingers of the right hand, which is where the “right-hand rule” originates:

General "right-hand rule"
for vector cross-products

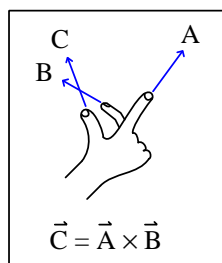

"Right-hand rule" specific
to the Lorentz force

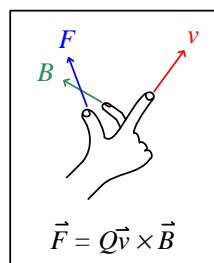

When holding the index finger, middle finger, and thumb of your right hand perpendicular to each other, your index finger points in the direction of the velocity vector (\vec{v}), your middle finger in the direction of the magnetic field vector (\vec{B}), and your thumb in the direction of the force vector (\vec{F}). A simple mnemonic I use to remember these relationships of fingers to vectors is that the **I**ndex finger points in the direction of current² (I), the **M**iddle finger points in the direction of the **m**agnetic field (B), and the **T**humb points in the direction of the **t**hrust (i.e. force) acting upon the moving charge.

The Lorentz force’s effect on electrically-charged particles in motion has many applications, from redirecting the paths of charged-particle beams in particle accelerator machines, to bending the trajectory of electron beams in a cathode-ray tube (CRT), to forcing electrons to travel in spiral or circular trajectories inside of magnetron (microwave oscillator) tubes. An illustration of a positively-charged particle curving perpendicular to a magnetic field appears here:

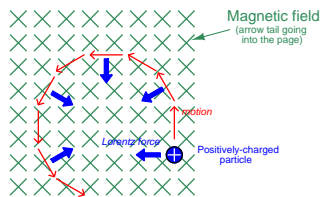

²Some textbooks speak of a “left-hand rule” which is intended to make sense of electric charge motion (current) in terms of *electron flow*. As we know, electrons are the only real mobile charge carriers within metal conductors, and so technically “electron flow” notation is most physically accurate when describing the motion of electric charges in metallic circuits. However, the right-hand rule is a *mathematical definition* for vector cross products, the concept of the cross product arising in the late 18th century when electrical science was still in its infancy. Early explorers of electricity used the established mathematical tools of their time and applied it to their work with electric currents and magnetism. At that time, charge carriers in metal wires were assumed to be “positive” and this is how the motion of positively-charged carriers became associated with the first vector of the cross-product. As a result of this assumption which was later proven false, we have two different conventions for denoting the motion of electricity: electron-flow which is *physically* accurate (for metal wires, at least), and conventional flow which is *mathematically* accurate. This, perhaps more than any other reason, is why educational programs designed for mathematically rigorous fields (e.g. electrical engineering) exclusively use conventional flow notation rather than electron flow notation to denote the direction of current.

If the moving charge in question is not a single charged particle but rather part an electric *current* passing through a conductor parallel to the first, both conductors will experience a mutually-attracting force given by the following equation:

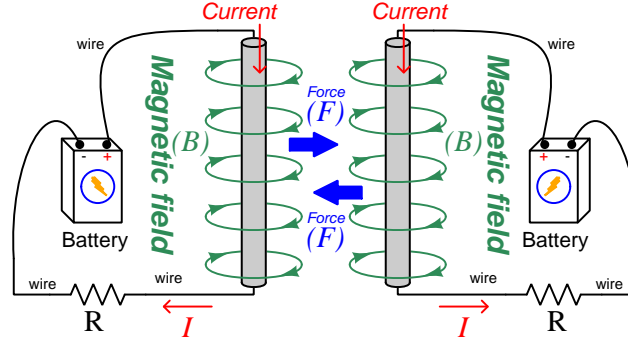

$$\vec{F} = I\vec{l} \times \vec{B}$$

Where,

\vec{F} = Force exerted on both conductors (Newtons)

I = Current (Amperes)

\vec{l} = Length of wire (meters)

\vec{B} = Magnetic field (Tesla, or Webers per square meter, or Newtons per Ampere-meter)

The point-charge Lorentz force equation and the two-conductor Lorentz force equation are not that different from one another. Dimensional analysis validates this: the Lorentz force on a moving charge uses that charge quantity (Coulombs) multiplied by the point-charge's velocity in meters per second to give Coulomb-meters per second for the first term:

$$Q\vec{v} = [\text{C}] \left[\frac{\text{m}}{\text{s}} \right] = \left[\frac{\text{C} \cdot \text{m}}{\text{s}} \right]$$

The Lorentz force on a current-carrying conductor uses the current (Amperes, which is Coulombs per second) multiplied by length in meters, for the same composite units of Coulomb-meters per second:

$$I\vec{l} = \left[\frac{\text{C}}{\text{s}} \right] [\text{m}] = \left[\frac{\text{C} \cdot \text{m}}{\text{s}} \right]$$

This dimensional equivalence makes conceptual sense as well: an electrically-charged particle moving through empty space is an electric current in its own right, and an electric current flowing through a conductor is just a collection of charged particles moving through space (just not *empty* space). In either case, the basis for the Lorentz force remains the same: the moving charge(s) create their own magnetic field, which reacts with the magnetic field of the original current-carrying wire to produce forces acting on both.

If the two currents flow in the same direction, their mutual forces *attract*. If the two currents flow in opposite directions, their mutual forces *repel*. This is the basis of electric motors: causing

mechanical motion by electro-magnetic attraction and repulsion. It also represents an interesting contrast with electric fields:

With electric fields, opposite *charges* attract and like *charges* repel.

With magnetic fields, opposite *poles* attract and like *poles* repel.

With parallel currents, opposite *directions* repel and like *directions* attract³.

Two parallel current-carrying conductors of length l and separated by a distance d will generate a mutual force proportional to both their currents:

$$F = l \frac{\mu I_1 I_2}{2\pi d}$$

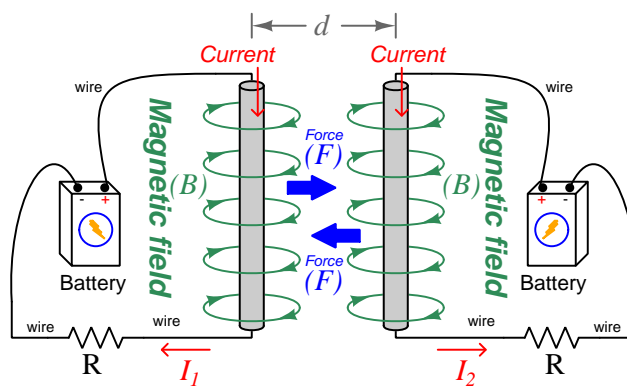

³That is, assuming it's *like* charges moving in these directions! If the charges in question are opposite each other – for example electrons in one circuit and holes in another – then like directions will repel and opposite directions will attract!

The circular loops surrounding the current-carrying conductors in the previous illustrations represent the magnetic lines of *flux* (Φ_B) surrounding each of those conductors. The magnetic field (B) is related to magnetic flux by area (A), the field being a measurement of how densely-packed those flux lines are per unit area. For this reason, magnetic field (B) is more properly known as *magnetic flux density*:

$$\vec{B} = \frac{\Phi_B}{\vec{A}}$$

Where,

\vec{B} = Magnetic field or flux density (Tesla, Webers per square meter, or Newtons per Ampere-meter)

Φ_B = Magnetic flux (Webers)

\vec{A} = Area over which flux is distributed (square meters)

An older unit of measurement for magnetic flux density B is the *Gauss* which is much smaller than a Tesla, with one Tesla equivalent to 10,000 Gauss. To put things into perspective, the Earth's natural magnetic field has a strength of approximately one-half of one Gauss⁴.

Magnetic field strength is an inverse function of distance from any current-carrying wire, and also depends on the magnetic permeability of the space adjacent to the wire:

$$B = \frac{\mu I}{2\pi d}$$

Where,

B = Magnetic field or flux density (Tesla, Webers per square meter, or Newtons per Ampere-meter)

μ = Magnetic permeability of the surrounding space (Tesla-meters per Ampere, $4\pi \times 10^{-7}$ for empty space)

I = Current (Amperes)

d = Distance from conductor (meters)

⁴Using the online *Magnetic Field Calculator* application provided by NOAA (the National Oceanic and Atmospheric Administration) at <https://ngdc.noaa.gov/geomag/calculators/magcalc.shtml#igrfwmm>, applying the World Magnetic Model WMM modeling algorithm for years 2019-2024, the total magnetic field strength at my home is 53,584.4 nano-Tesla (53,584.4 nT or 0.535844 Gauss), and presently (May 2020) decaying at a rate of -104.1 nT per year.

The relation of magnetic *flux* to current through a conductor follows a similar equation:

$$\Phi = \frac{\mu AI}{2\pi d}$$

Where,

Φ = Magnetic flux (Webers)

μ = Magnetic permeability of the surrounding space (Tesla-meters per Ampere, $4\pi \times 10^{-7}$ for empty space)

A = Area over which flux is distributed (square meters)

I = Current (Amperes)

d = Distance from conductor (meters)

As this equation makes clear, the amount of magnetic flux surrounding a current-carrying conductor depends not only on the amount of current, but also on the sampled area, the distance from the wire, and also the surrounding material. Most⁵ substances (gas, liquid, solid) have permeability values greater than that of empty space, and so this means magnetic flux is usually *enhanced* by the presence of matter around the current-carrying conductor.

The total magnetic flux enclosed by a circular wire loop follows a similar equation:

$$\Phi = \frac{\pi\mu Ir}{2}$$

Where,

Φ = Magnetic flux (Webers)

μ = Magnetic permeability of the surrounding space (Tesla-meters per Ampere, $4\pi \times 10^{-7}$ for empty space)

I = Current (Amperes)

r = Radius of circular loop (meters)

⁵Interestingly, superconducting materials *forbid* magnetic fields inside of their bulk, and so the permeability value of any superconductor must be zero!

A common form of electromagnet known as a *solenoid* takes the form of a wire coil wrapped in such a way as to form a long⁶ cylinder, often wrapped around a plastic frame, and often with a ferromagnetic material such as iron in the center:

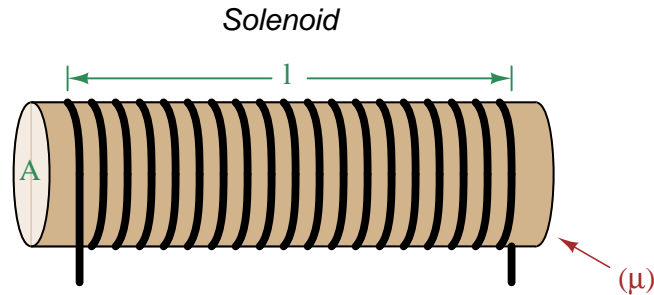

The amount of magnetic flux, and the flux density, within the interior of a current-carrying solenoid are given by the following formulae:

$$\Phi = \frac{\mu N A I}{l} \qquad B = \frac{\mu N I}{l}$$

Where,

Φ = Magnetic flux (Webers)

B = Magnetic field or flux density (Tesla, Webers per square meter, or Newtons per Ampere-meter)

μ = Magnetic permeability of the surrounding space (Tesla-meters per Ampere, $4\pi \times 10^{-7}$ for empty space)

N = Number of turns of wire in the coil

A = Cross-sectional area of solenoid coil (square meters)

I = Current (Amperes)

l = Length of solenoid coil (meters)

These formulae have interesting implications for solenoid design. Note how a shorter (i.e. smaller length l) solenoid identical in all other respects will generate a stronger magnetic field for a given current. Note also how the flux density (B) remains constant with increasing cross-sectional area (A) if all other factors are equal, and that this necessarily means a greater amount of total magnetic flux (Φ) for a greater area A .

⁶These magnetic field formulae apply perfectly to a solenoid coil that is closely-packed (i.e. each turn adjacent to the next) and infinitely long. Therefore, they only approximate real solenoid behavior. This fact may be understood by performing a thought experiment where we decrease the solenoid coil's length to zero, in which case the formulae predict an *infinite* amount of magnetism for any amount of current at all, which of course cannot be true.

Another common form of electromagnet known as a *toroid* is really just a solenoid bent in a circle so that its two ends meet⁷ cylinder, often wrapped around a plastic frame, and often with a ferromagnetic material such as iron in the center. Toroids have the unusual property of *containing* their magnetic flux lines extremely well, unlike solenoids, wires, and simple coils which all radiate magnetic fields. They find application as energy-storage devices, or as electromagnets suitable for applying magnetic fields to specimens placed *inside* the toroid's cross-section:

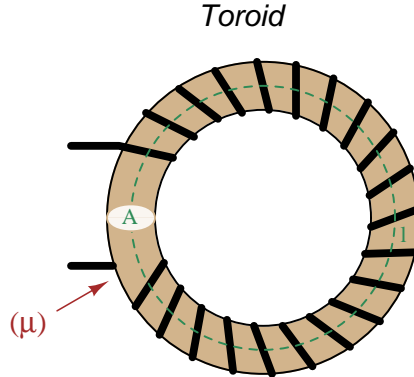

The amount of magnetic flux, and the flux density, within the interior of a current-carrying toroid are identical to that within an otherwise identical otherwise identical solenoid having a length (l) equal to the toroid's circumference:

$$\Phi = \frac{\mu N A I}{l} \qquad B = \frac{\mu N I}{l}$$

Where,

Φ = Magnetic flux (Webers)

B = Magnetic field or flux density (Tesla, Webers per square meter, or Newtons per Ampere-meter)

μ = Magnetic permeability of the surrounding space (Tesla-meters per Ampere, $4\pi \times 10^{-7}$ for empty space)

N = Number of turns of wire in the coil

A = Cross-sectional area of toroid (square meters)

I = Current (Amperes)

l = Circumference of toroid (meters)

If we wish to substitute toroid radius (r) for circumferential length (l), the formulae become the following:

$$\Phi = \frac{\mu N A I}{2\pi r} \qquad B = \frac{\mu N I}{2\pi r}$$

⁷Again, the magnetic field formulae are only accurate for a toroidal coil that is closely-packed (i.e. each turn adjacent to the next) and infinitely long, and therefore only approximate real toroid behavior. This fact may be understood by performing an equivalent thought experiment as before where we decrease the toroid's circumference to zero and absurdly end up with *infinite* magnetism for a finite current.

Many applications of electromagnetism involve conductive *coils* wrapped around some form of ferromagnetic core material, the purpose of that core being to provide a higher-permeability pathway for the magnetic flux than would exist otherwise through air, and the purpose of the wire coil being to intensify the amount of magnetism developed by the electric current beyond what would be possible with a straight current-carrying wire. These magnetic cores typically form a closed loop, or *magnetic circuit* for the lines of magnetic flux to naturally form a closed path. A simple example appears here:

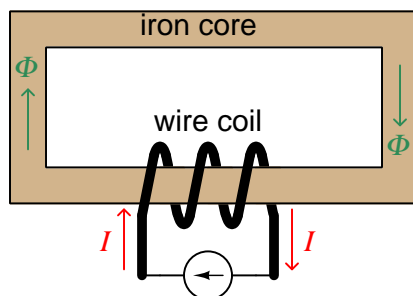

The amount of magnetic flux (Φ) present in the magnetic “circuit” formed by the iron core depends on many factors. First and foremost is the amount of electric current (in Amperes) passing through the wire coil and the number of turns that coil makes around the iron core. The product of this current and the number of turns is called the *magnetomotive force* or *mmf* of the magnetic circuit, analogous to “electromotive force” or “emf” often used as a synonym for voltage in an electric circuit. Not surprisingly, the standard metric unit of measurement for magnetomotive force is the *Ampere-turn*.

However, magnetomotive force alone does not fully describe the current’s effect on magnetism within the iron core. The total length of the magnetic circuit is also an important factor, since a longer path distributes that magnetomotive force over a greater distance. The quotient of magnetomotive force and magnetic circuit length is called *magnetic field intensity*, symbolized by the variable H and expressed in units of *Ampere-turns per meter*.

Magnetic permeability (μ) relates magnetic field intensity (H) to the magnetic flux density (B) within the core material, such that a greater permeability will result in higher flux density for any given amount of field intensity. Permeability is a property of the core material and not its geometry, mathematically defined as the ratio of flux density to field intensity: $\mu = \frac{B}{H}$

Magnetic reluctance (\mathfrak{R}) relates magnetomotive force (mmf) to magnetic flux (Φ), and is related not only to the core material’s permeability but also its geometry. It is mathematically defined as the ratio of magnetomotive force to magnetic flux: $\mathfrak{R} = \frac{\text{mmf}}{\Phi}$

If all this seems confusing, you are in good company. Not only are there many magnetic variables, some related to physical geometry and others not, but there are *two different sets of metric units* appropriate for expressing each! The older units were based on the centimeter-gram-second (CGS) version of the metric system, while the newer units are based on the meter-kilogram-second or SI (Système International) version of the metric system.

Quantity	Symbol	SI unit	CGS unit
Magnetomotive force	mmf	Ampere-turn (A-t)	Gilbert (Gb)
Flux	Φ	Weber (Wb)	Maxwell (Mx)
Field intensity	H	Ampere-turns per meter (A-t/m)	Oersted (Oe)
Flux density	B	Tesla (T)	Gauss (G)
Permeability	μ	Tesla-meters per Ampere-turn (T-m/A-t)	Gauss per Oersted (G/Oe)
Reluctance	\mathfrak{R}	Ampere-turns per Weber (A-t/Wb)	Gilberts per Maxwell (G/Mx)

Magnetomotive force (mmf) and magnetic flux (Φ) may be thought of as the “raw” measures of magnetism, with Ampere-turns and Webers being their respective SI metric units. Reluctance (\mathfrak{R}) is the ratio of the two for any given magnetic circuit with known dimensions and core material. Simply put, reluctance tells you how many Ampere-turns of magnetomotive force will be necessary to create one Weber of magnetic flux in a given space.

Magnetic field intensity (H) and magnetic flux density (B) may be thought of as the “normalized” measures of magnetism, with Ampere-turns per meter and Tesla being their respective SI metric units. H and B relate to mmf and flux by the physical dimensions of the magnetic circuit (length and cross-sectional area, respectively). Permeability is the ratio of the two for any given magnetic core material. Simply put, permeability tells you how many Tesla of magnetic field (i.e. flux density, or Webers of flux per square meter or cross-sectional core area) you will obtain for one Ampere-turn per meter of magnetic field intensity applied to a given core material.

Conversion between the newer SI and the older CGS metric units are as follows:

Quantity	Conversion equivalence
Magnetomotive force (mmf)	1 Ampere-turn = $\frac{4\pi}{10}$ Gilberts
Magnetic flux (Φ)	1 Weber = 10^8 Maxwells
Magnetic field intensity (H)	1 Ampere-turn/meter = $\frac{4\pi}{1000}$ Oersteds
Magnetic flux density (B)	1 Tesla = 10^4 Gauss
Permeability (μ)	1 Tesla-meter/Ampere-turn = $\frac{10^7}{4\pi}$ Gauss/Oersteds
Reluctance (\mathfrak{R})	1 Ampere-turn/Weber = $\frac{4\pi}{10^9}$ Gilberts/Maxwell

6.2 Calculating winding turns

Basic transformer calculations rely strictly on the *ratio* of turns between primary and secondary windings. For example, a power transformer with a voltage step-down ratio of 3:1 must have three times as many turns of wire in its primary than in its secondary. On this basis alone we might be tempted to conclude that a transformer having 3000 turns in its primary and 1000 turns in its secondary will perform just the same as a transformer having 30 turns in its primary and 10 turns in its secondary, but this is actually not correct. Here we will examine just some of the other considerations determining the proper number of turns for any transformer's windings:

- **Magnetic saturation** – this is a phenomenon where the ferromagnetic core material of a transformer becomes “saturated” with lines of magnetic flux, resulting in less additional magnetic flux for additional increases in winding current. Saturation leads to excessive energy dissipation and other undesirable effects. One mitigation technique is to design the transformer with enough turns of wire in its primary winding to avoid needing excessive accumulations of magnetic flux in its core at any given time. Another mitigation technique is to use a magnetic core with a large cross-sectional area to disperse that magnetic flux sufficiently so the flux *density* does not become too great.
- **Magnetizing current** – this is the amount of AC current drawn by an energized primary winding when there is no load connected to the secondary. It represents the primary current necessary to create enough magnetic flux in the core to balance the applied primary voltage.
- **Energy dissipation** – this takes two major forms: *core losses* (often called “iron losses”) and *winding losses* (often called “copper losses”). A transformer primary winding with many turns will exhibit less core loss due to a decreased magnetic flux requirement, but will exhibit greater winding loss due to the added resistance of longer wire needed to make that many turns around the core.

As with most things in engineering, determining the number of turns of wire to use for a transformer's windings is a compromise between competing interests. This is a surprisingly complicated topic, and this reference will only highlight some of the more basic considerations, which means you should consult a specialized reference text for an entire transformer design procedure.

Faraday's Law of Electromagnetic Induction is helpful here, showing the relationship between voltage induced in any coil of wire by a varying magnetic field:

$$V = N \frac{d\Phi}{dt}$$

Where,

V = Voltage applied to the coil or induced by the coil (Volts)

N = Number of turns of wire

$\frac{d\Phi}{dt}$ = Rate of change of magnetic flux (Webers per second)

Let's consider a square-wave AC voltage applied to an unloaded transformer (i.e. no load connected to the secondary winding, just the source connected to the primary). Even though it is more common to energize a transformer with a *sinusoidal* voltage source, we will use a square wave here because it makes the math easier to understand, and it also represents a worst-case scenario in terms of magnetic flux requirement, which means any design based on this square-wave assumption should perform well with sinusoidal energization:

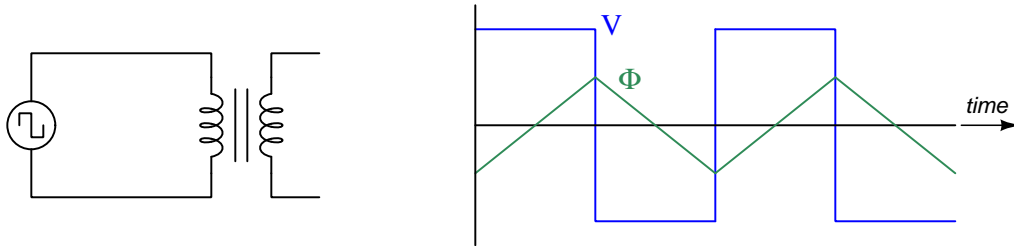

In order for the primary winding to drop a voltage equal to the source at every point in time, the magnetic flux must rise and fall at a rate predicted by Faraday's Law. Since voltage (V) is constant during each half-cycle of the square wave, this means the rise and fall of magnetic flux (Φ) must be constant as well, resulting in straight-line increases and decreases over time.

If we were to increase the number of turns in this transformer's secondary, the magnetic flux would not have to rise and fall as rapidly:

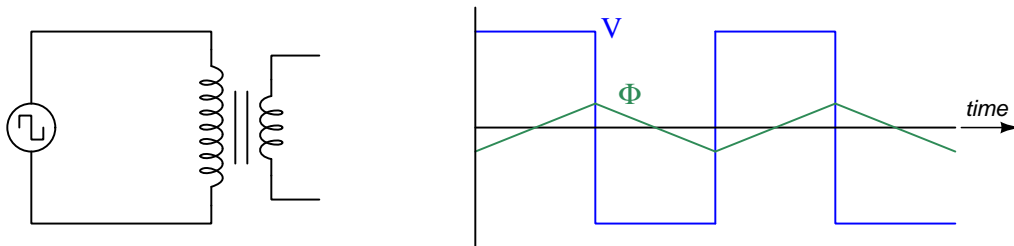

This makes mathematical sense: increasing N means less $\frac{d\Phi}{dt}$ is necessary to drop the same V .

Ferromagnetic cores have limited capacity for magnetic flux before they begin to saturate, these limits usually specified in terms of magnetic flux density (B). Whereas magnetic flux is measured in Webers, magnetic flux density is measured in Tesla which is equivalent to Webers per square meter of cross-sectional core area:

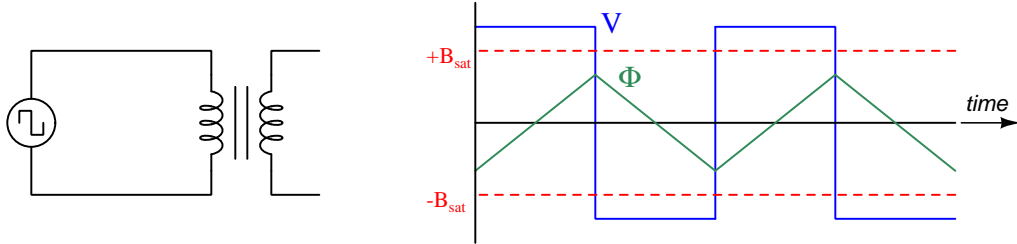

We must avoid crossing these maximum magnetic limits in order to avoid saturation. In practice, though, we try to design the transformer for flux levels well within these saturation limits for the sake of reducing core losses.

Here is where our decision to model the system using square-wave excitation pays dividends: since the voltage in each half-cycle of the square wave is constant, and the magnetic flux rises and falls linearly over time, we may re-write Faraday's Law using discrete differences (Δ) rather than continuous differentials (d):

$$V_{square} = N \frac{\Delta\Phi}{\Delta t}$$

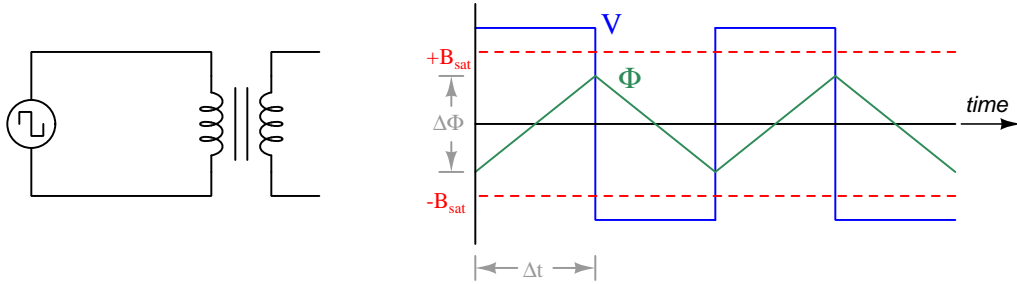

Mathematically solving for the correct number of turns is as simple as manipulating the Faraday's Law equation. The numerator's units of measurement here are *Volt-seconds*:

$$N = \frac{(V_{square})(\Delta t)}{\Delta\Phi}$$

Since core materials are typically rated in terms of B rather than Φ , we may modify the equation using the substitution $\Phi = BA$:

$$N = \frac{(V_{square})(\Delta t)}{(\Delta B)(A)}$$

Let's apply this to a realistic scenario. Suppose our transformer primary winding will be energized by 120 Volts RMS at a frequency of 60 Hz, using a core with a B_{sat} limit of 1 Tesla and a core area of 6.5 cm^2 . In principle with saturation limits of ± 1 Tesla, the maximum ΔB would be 2 Tesla. However, a more conservative approach would be to design the transformer for a much lesser magnetic flux density than this. We will use a maximum value of 0.5 Tesla ΔB so that the symmetrical peak values of magnetic flux density should not exceed ± 0.25 Tesla, just one-quarter of the advertised saturation limit.

A 120 Volt RMS sine wave actually peaks at ± 169.71 Volts, and so we will assume the application of a 170 Volt square wave. A 170 Volt square wave will definitely accumulate a larger Volt-second product than a 169.71 Volt (peak) sine wave, which means the number of turns we calculate using the square-wave scenario will actually result in less magnetic field in the transformer's core than our chosen limits of ± 0.25 Tesla. It is important to bear in mind that our calculations here are biased in a conservative direction, meaning we will "over-engineer" our transformer's primary winding to have more turns than strictly necessary in order to remain safely distant from saturation.

Next we need to determine the time period over which the magnetic flux must rise (and later, over which it will fall), our Δt value. This is one-half of a full cycle, which at 60 Hz is $\frac{1}{120}$ of a second, or 8.333 milliseconds.

Lastly, we need to convert the given cross-sectional area from square centimeters to square meters. Using the "unity fractions" method of unit conversion:

$$\left(\frac{6.5 \text{ cm}^2}{1}\right) \left(\frac{1 \text{ m}}{100 \text{ cm}}\right)^2 = 6.5 \times 10^{-4} \text{ m}^2$$

Plugging these values into the equation:

$$N = \frac{(V_{square})(\Delta t)}{(\Delta B)(A)}$$

$$N = \frac{(170 \text{ V})(8.333 \times 10^{-3} \text{ s})}{(0.5 \text{ T})(6.5 \times 10^{-4} \text{ m}^2)} = 4358.97 \text{ turns}$$

Rounding up to a whole number of turns gives us 4359 turns for this transformer's primary winding. Now that we know the number of primary turns, we may select an appropriate number of secondary turns to achieve whatever step-up or step-down ratio we might desire. For example, if we want our transformer to output 15 Volts RMS when energized by 120 Volts RMS on the primary:

$$\frac{V_P}{V_S} = \frac{N_P}{N_S}$$

$$N_S = \frac{N_P V_S}{V_P}$$

$$N_S = \frac{(4359 \text{ turns})(15 \text{ V})}{120 \text{ V}} = 544.875 \text{ turns}$$

For a power transformer application we would want more turns in the secondary winding than this, in order to compensate the inevitable voltage drops resulting from currents passing through the resistances of the long primary and secondary wires, as well as voltage drops originating from leakage inductance, but 545 turns is an approximate value to start with.

6.3 Transformer parasitics

An ideal transformer couples electrical energy from its primary winding to its secondary winding(s) with no energy loss (i.e. dissipation) and with no additional impedance standing in the way of that energy transfer. When unloaded, an ideal transformer draws no current whatsoever from its connected source. Real transformers, however, fall quite short of these ideal characteristics. The following diagram models some of the parasitic effects observed in real transformers:

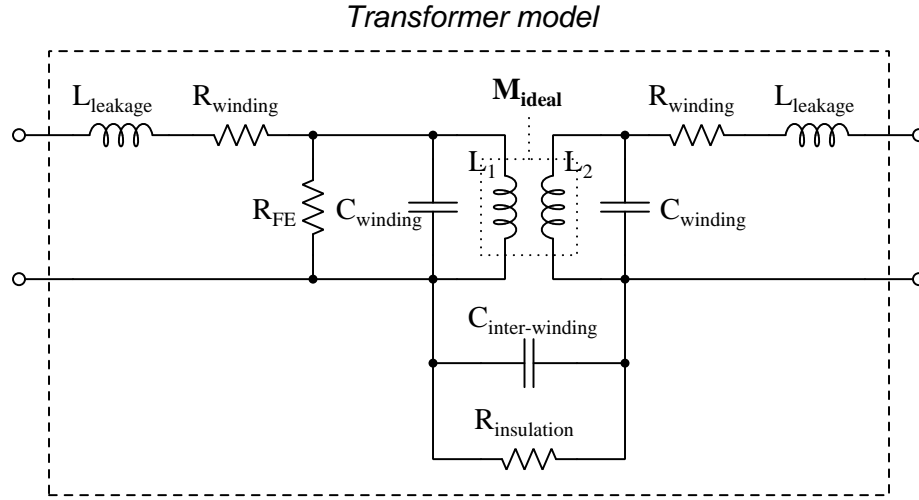

Each of the transformer's windings have resistance owing to the specific resistance of the metal making up those wire windings, this winding resistance effectively being in series with each winding. Additionally, each winding has *leakage inductance* which is the result of magnetic flux that does not couple between the two windings but instead merely stores and releases energy like the self-inductance of a single inductor. Together, winding resistance and leakage inductance contribute to the *impedance* of the transformer, limiting its ability to seamlessly transfer energy from primary to secondary circuits.

We also see each winding suffering from capacitance, resulting from the insulation between adjacent turns of wire. The presence of this parasitic capacitance, something found in every inductor as well as in transformers, means the primary and secondary windings are able to *self-resonate* at certain frequencies. Note also that there is capacitance coupling between the primary and secondary windings, which means no transformer can ever *perfectly* isolate the primary and secondary circuits from each other.

Lastly we have a resistance shown in the model as R_{FE} representing dissipative losses in the iron core material from effects such as hysteresis and magnetostriction. This is often referred to as *iron loss* (as opposed to the *copper loss* of winding resistance).

Next we will explore common mechanisms for each of these effects.

6.3.1 Parasitic resistance in transformers

Winding resistance depends on the size and composition of wire used to make each winding. Using low-resistivity metal and wire of sufficiently large gauge are really the only ways to minimize this parasitic effect. Using a transformer with over-sized wire (i.e. a transformer having current ratings in excess of the currents expected in your application) is one way to reduce this parasitic effect using commonly-available transformers.

So-called “iron loss” resistance is based on magnetic effects, primarily the hysteresis curve for the iron alloy. Modern silicon-steel alloys formulated for transformer applications enjoy very narrow B-H hysteresis curves which in turn translate to low levels of energy dissipation as the core magnetizes in one polarity, de-magnetizes, and re-magnetizes in the other polarity with each cycle of the energizing AC. Using a transformer with an over-sized magnetic core has the result of dispersing the magnetic flux over a larger cross-sectional area, resulting in less magnetic flux density (B) with all other factors being equal. One way to specify a transformer with an over-sized magnetic core is to select one with a higher voltage rating than your application strictly needs, as peak magnetic flux density for any given AC frequency is a function of the peak voltage experienced by each winding. If frequency is not variable, then the cycle time (period) of the AC waveform will likewise be fixed, and since total magnetic flux in any inductor is the integral of voltage and time (i.e. the *Volt-second product*) it means a transformer with a higher voltage rating must possess a larger magnetic core.

6.3.2 Leakage inductance in transformers

Leakage inductance, another contributing factor of transformer impedance, results from some of the core’s magnetic flux not coupling perfectly between primary and secondary windings. Core shape and material choice affect this parameter, with toroidal transformer cores generally performing better than cores having abrupt corners.

6.3.3 Parasitic capacitance in transformers

Capacitance unavoidably exists between adjacent turns of wire in any inductor, and also between adjacent turns of primary and secondary windings in a transformer. Reducing turn-to-turn parasitic capacitance within any single winding requires those turns be spaced farther apart from each other, or wound in different patterns, or with an insulating material having a lower dielectric permittivity.

Primary-to-secondary winding capacitance can be mitigated to a large extent by placing an electrostatic *shield* between the two windings of the transformer and connecting that shield conductor to Earth ground. This works precisely the same way as wrapping a foil or braided shield conductor around a multi-conductor cable in order to shield those conductors from electric fields external to the cable. In this case, the shielding stops electric flux lines from linking from one winding to another. Shielded-winding transformers are more expensive to manufacture than their unshielded counterparts.

Another mitigation technique for primary-to-secondary parasitic capacitance is to use a *split-bobbin* transformer where the primary and secondary windings do not overlap each other, but rather are placed at different locations around the magnetic “circuit” formed by the iron core. This increases the separation distance between these two windings without significantly affecting other performance parameters of the transformer, but of course has the effect of increasing the over-all size of the transformer.

6.3.4 Excitation and magnetization currents

As described at the beginning of this section, an ideal transformer draws no current whatsoever from its energizing source. This, however, is possible only by meeting two idealized conditions:

- The primary winding inductance must be infinite
- Magnetic core losses must be zero (i.e. a lossless core)

An infinite primary winding inductance is simply impossible to achieve in any real transformer, though we may approach this ideal by building transformers whose primary inductance values are quite large. Large primary inductance means large values of inductive reactance ($X_L = 2\pi fL$), and so the larger the winding's inductance is the less *magnetization current* it will need to draw from an AC voltage source to create a rate-of-change of magnetic flux in the core sufficient to balance the applied source voltage as per Faraday's Law of Electromagnetic Induction ($V = N \frac{d\phi}{dt}$).

A lossless core material is similarly impossible to achieve in most real transformers, as all ferromagnetic materials invariably dissipate at least *some* energy when magnetized and demagnetized, and air/vacuum-core transformers become impractically large for typical AC power system frequencies (in order to achieve large amounts of inductance, as necessitated above).

Referencing our transformer model showing various parasitic and ideal effects, magnetization current is that amount of current drawn by ideal primary inductance L_1 when the secondary is unloaded (i.e. open-circuited). This, combined with the current drawn from the AC voltage source as a result of the iron losses (R_{FE}), is called *excitation current*. Thus, $I_{excite} = I_{L_1} + I_{R_{FE}}$ which is a phasor current sum, I_{L_1} lagging the applied voltage by 90° and $I_{R_{FE}}$ being in-phase with the applied voltage. If the excitation current is measured using an instrument such as an oscilloscope capable of comparing phase angles between the measured current and the applied voltage, magnetization current will be the imaginary portion of the excitation current while core-loss current will be the real portion.

6.3.5 Transformer testing

The following list shows typical tests for transformers at the time of manufacture:

- **DC winding resistances** – the simplest of these to measure, using a multimeter
- **Winding inductances/impedances** – performed by exciting one winding with an AC source and comparing voltage/current, typically using either an LCR meter or an impedance analyzer
- **Turns ratio** – performed by exciting one winding with an AC current source and measuring another winding’s short-circuited current using an AC ammeter
- **Winding polarity/phase-shift** – performed by exciting one winding with an AC voltage and measuring another winding’s induced voltage, an oscilloscope used to compare the phases of each voltage
- **Core saturation** – performed by exciting one winding with a sinusoidal AC current and measuring another winding’s induced voltage until a non-sinusoidal waveshape is detected, or more crudely by determining when the induced voltage no longer increases proportionately to increased excitation current
- **Excitation current** – performed by exciting one winding with an AC voltage and measuring current drawn by that winding
- **Insulation resistance** – performed with a “Hi-Pot” (high-potential) insulation tester, generally connecting one terminal to both ends of one winding and the other tester terminal to both ends of another winding, this infers insulation resistance by applying (typically) several thousand Volts DC while measuring the small current passing through the stressed insulation

A more thorough battery of tests used during transformer design development might include the following:

- **Linearity** – turns ratio testing performed at several different amounts of excitation current, checking to see how consistent the effective turns ratio is over a wide range
- **BH loop** – performed by exciting one winding with an AC voltage and measuring the voltage induced in another winding, that induced voltage representing the rate-of-change of magnetic flux which may be mathematically integrated to infer the amount of magnetic flux, those two variables being plotted using an oscilloscope’s X-Y mode much like “curve tracing” for a semiconductor component
- **High-voltage impulse** – similar to an insulation resistance test, this uses a high-voltage DC pulse applied across one winding to stress turn-to-turn insulation resistance
- **Volt-second** – performed by applying a DC voltage pulse to one winding while measuring current through it, the ideal response being a linear-ramping current whose magnitude is proportional to the Volt-second product of the applied pulse
- **Overload** – subjecting a winding to dramatic overcurrent to thermally and mechanically stress the transformer as it might be in an overloaded power system scenario

6.4 Manufacturing shell-type transformers

The following photograph shows a shell-type, split-bobbin transformer in various stages of assembly, the individual components mounted on a board for easy visualization of the manufacturing process:



At the “Pin Insertion” stage, metal pins are inserted into slots in the plastic bobbin which will later hold the wire windings (“turns”) of the transformer’s primary and secondary coils. These metal pins are subsequently bent to right angles in the “Pin Bending” stage.

Wrapping thin-gauge enamel-coated copper wire around these plastic bobbins is a task performed by machine, the final result shown in the “Winding” examples.

At the “Soldering” stage, the enamel insulation at the ends of the wires is removed, and those wire ends soldered to the metal pins.

In the “Assembly” stage, the primary and secondary bobbins are arranged in such a fashion as to receive the “E” and “I” iron sheets. These E-shaped and I-shaped pieces of iron sheet-metal are then stacked inside and around the bobbin assembly to form the iron core to complete the magnetic circuit through the centers of both windings.

Finally, at the “Varnish” stage, the assembled transformer is coated with varnish to seal up its internal components from ambient conditions that could harm it, such as moisture.

Here we will examine some of these stages in closer detail. On the left we see a photograph of the two plastic bobbins prior to any pin insertion or winding of wire coils, and on the right we see these bare bobbins stacked together as they eventually will be in the assembled transformer:

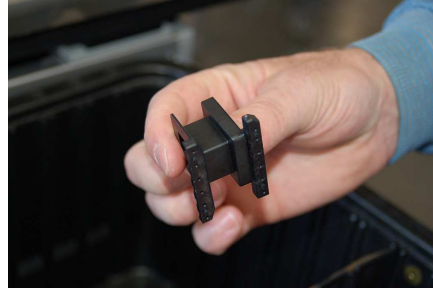
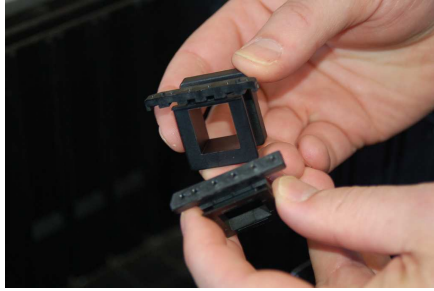

Next, we see photos of a small bobbin clamped in the spindle of a winding machine (left), and the winding process in action (right) where the spindle turns the bobbin rapidly as wire is fed from a spool onto the rotating spindle:



This same winding process is seen here for two of the larger-sized bobbins, wound simultaneously on the same machine:

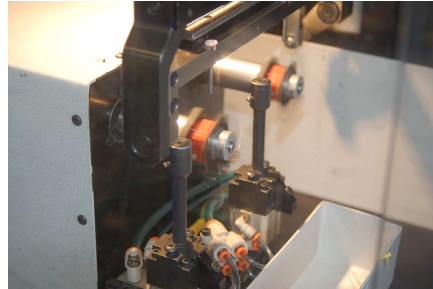
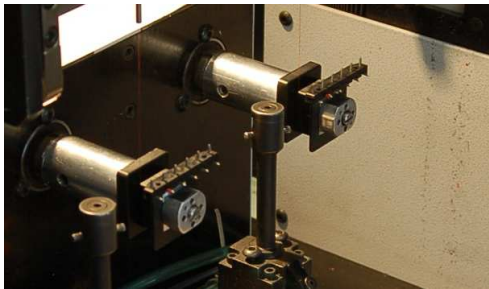

Completely-wound bobbins appear here for inspection, the low-turns bobbin on the left and the high-turns bobbin on the right:

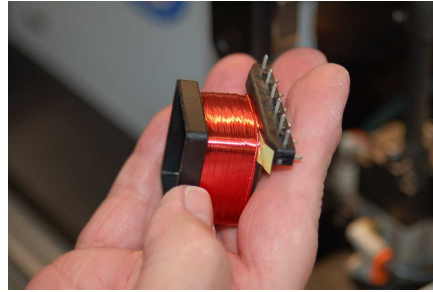
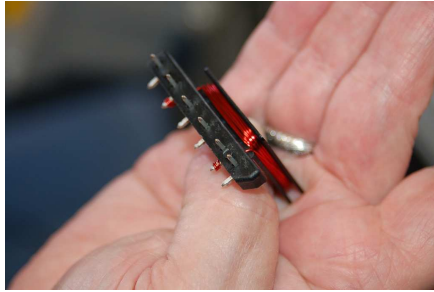

With the bobbins fully wound with enameled wire, their empty centers may be filled with laminated sheets of E-shaped and I-shaped iron to form a magnetic circuit through and around the wire coils. These I-shaped and E-shaped iron pieces appear in the left-hand photograph below, and a hand-crank “stacking” machine shown in the right-hand photo alternately feeds E-shaped pieces from one side and I-shaped pieces from another into the centered bobbins:

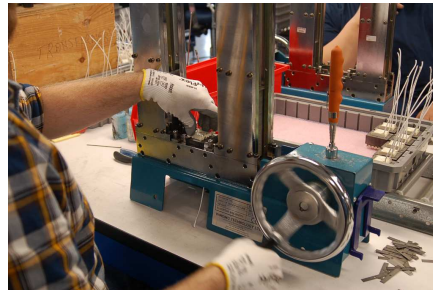

A closer view (below, left) shows the stacking machine feeding iron pieces from two stacks on the left and right of the bobbin assembly. This semi-automatic stacking process is imperfect, though, with the machine susceptible to jamming due to iron pieces that are not flat enough or that have burred edges. Thus, some transformer cores require final hand-assembly as shown below (right):

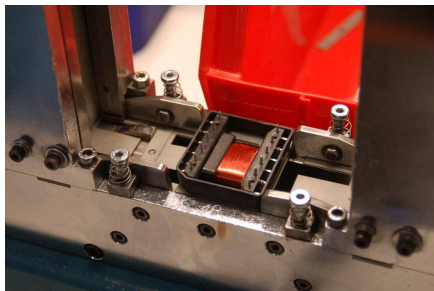

6.5 Manufacturing toroidal transformers

The following photograph shows a toroidal-core PCB-mount current transformer in various stages of assembly, the individual components mounted on a board for easy visualization of the manufacturing process:



At the “Core” stage we see thin layers of ferrite material formed into a toroid, and then in a later step encapsulated by a green-colored epoxy coating. This core is then placed in a special machine which winds the thin enamel-coated copper wire around its bulk. For most toroidal transformers, this “Core Winding” stage requires multiple coils of wire applied by the machine. In this particular case, since it is a current transformer with a single-turn primary winding, the winding machine only applies one coil of thin-gauge copper wire around the toroidal core as the secondary, the primary “winding” being a sheet-metal bracket bent to pass through the core just once, and installed in a later stage of assembly.

Next we see the “Pin Insertion” stage where metal pins are pressed into a plastic frame which will later enclose the wound toroidal core.

The “Assembly” stage stacks all these parts together, including the primary “winding” which is just a U-shaped piece of sheet-metal. At the “Soldering” stage, the secondary winding’s wire ends are soldered to the pre-inserted metal pins.

Finally, the assembled transformer is “Potted” in a dense epoxy compound to completely seal it from the external environment. Toward the bottom of the “Potted” display section we see a final transformer which has been cut in half by a bandsaw to show a cross-section of its internals.

Toroidal transformers are quite effective in their ability to contain their own magnetic fields with less “leakage” than “shell” type transformers. However, toroidal iron cores are not as easy to wind wire around as “shell” type transformers with cores made of stacked E-shaped and I-shaped iron pieces. The challenge is not difficult to perceive, as one must wind dozens of meters of thin-gauge enamel-insulated copper wire through the core’s center and around its periphery to form hundreds or even thousands of “turns”. Fortunately, enterprising minds have developed unique machines specifically suited for this task, the Jovil Universal model SMC-1S toroidal winder being one example.

In the example below we see a photograph of this machine. Central to its operation is a metal ring called a *shuttle* with a grooved circumference designed to hold a specified length of wire. This “shuttle” ring is split at one point allowing it to be separated so that a toroidal core may be inserted. Once inserted, the shuttle is re-connected and allowed to rotate through the center of the toroidal core, depositing its wire load onto the core as it turns. In this photograph, the shuttle is the shiny ring at the center of the machine:



Below we see photographs showing toroidal core loaded into its holding place⁸ while the shuttle ring is split open (left), and then preparing to load a length of wire onto the closed shuttle (right):

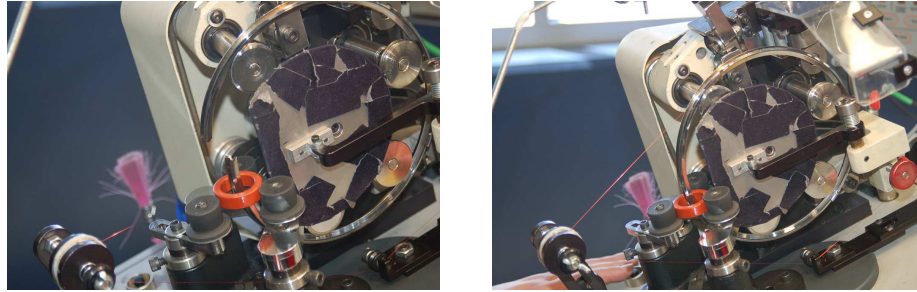

Once loaded with a length of enameled wire (left), one end of that wire is anchored and the shuttle is rotated in the reverse direction to deposit its load of wire onto the toroidal core, each rotation of the shuttle's ring laying down one turn of wire around the toroidal core (right) as the toroid itself slowly rotates to disperse these turns evenly around its circumference:

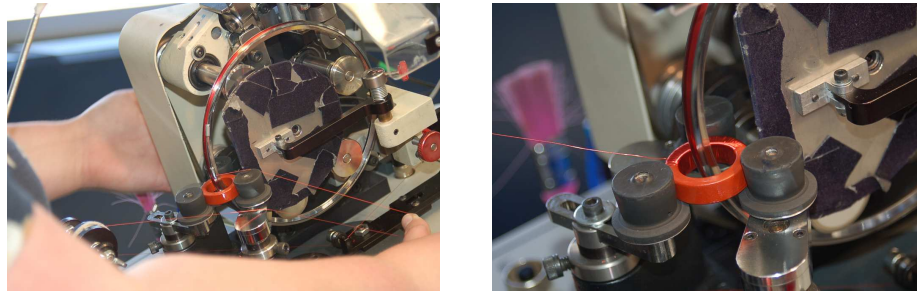

When complete, the shuttle will be empty of wire and the toroidal core will be completely wound and ready for soldering and assembly as a transformer.

⁸If you examine these photographs closely, you will see the orange-colored toroidal core held by three grey-colored roller wheels. These three rollers hold the toroid firmly while allowing it to rotate as the shuttle deposits its load of enameled wire onto the toroidal core.

Chapter 7

Questions

This learning module, along with all others in the ModEL collection, is designed to be used in an inverted instructional environment where students independently read¹ the tutorials and attempt to answer questions on their own *prior* to the instructor's interaction with them. In place of lecture², the instructor engages with students in Socratic-style dialogue, probing and challenging their understanding of the subject matter through inquiry.

Answers are not provided for questions within this chapter, and this is by design. Solved problems may be found in the Tutorial and Derivation chapters, instead. The goal here is *independence*, and this requires students to be challenged in ways where others cannot think for them. Remember that you always have the tools of *experimentation* and *computer simulation* (e.g. SPICE) to explore concepts!

The following lists contain ideas for Socratic-style questions and challenges. Upon inspection, one will notice a strong theme of *metacognition* within these statements: they are designed to foster a regular habit of examining one's own thoughts as a means toward clearer thinking. As such these sample questions are useful both for instructor-led discussions as well as for self-study.

¹Technical reading is an essential academic skill for any technical practitioner to possess for the simple reason that the most comprehensive, accurate, and useful information to be found for developing technical competence is in textual form. Technical careers in general are characterized by the need for continuous learning to remain current with standards and technology, and therefore any technical practitioner who cannot read well is handicapped in their professional development. An excellent resource for educators on improving students' reading prowess through intentional effort and strategy is the book *Reading For Understanding – How Reading Apprenticeship Improves Disciplinary Learning in Secondary and College Classrooms* by Ruth Schoenbach, Cynthia Greenleaf, and Lynn Murphy.

²Lecture is popular as a teaching method because it is easy to implement: any reasonably articulate subject matter expert can talk to students, even with little preparation. However, it is also quite problematic. A good lecture always makes complicated concepts seem easier than they are, which is bad for students because it instills a false sense of confidence in their own understanding; reading and re-articulation requires more cognitive effort and serves to verify comprehension. A culture of teaching-by-lecture fosters a debilitating dependence upon direct personal instruction, whereas the challenges of modern life demand independent and critical thought made possible only by gathering information and perspectives from afar. Information presented in a lecture is ephemeral, easily lost to failures of memory and dictation; text is forever, and may be referenced at any time.

GENERAL CHALLENGES FOLLOWING TUTORIAL READING

- Summarize as much of the text as you can in one paragraph of your own words. A helpful strategy is to explain ideas as you would for an intelligent child: as simple as you can without compromising too much accuracy.
- Simplify a particular section of the text, for example a paragraph or even a single sentence, so as to capture the same fundamental idea in fewer words.
- Where did the text make the most sense to you? What was it about the text's presentation that made it clear?
- Identify where it might be easy for someone to misunderstand the text, and explain why you think it could be confusing.
- Identify any new concept(s) presented in the text, and explain in your own words.
- Identify any familiar concept(s) such as physical laws or principles applied or referenced in the text.
- Devise a proof of concept experiment demonstrating an important principle, physical law, or technical innovation represented in the text.
- Devise an experiment to disprove a plausible misconception.
- Did the text reveal any misconceptions you might have harbored? If so, describe the misconception(s) and the reason(s) why you now know them to be incorrect.
- Describe any useful problem-solving strategies applied in the text.
- Devise a question of your own to challenge a reader's comprehension of the text.

GENERAL FOLLOW-UP CHALLENGES FOR ASSIGNED PROBLEMS

- Identify where any fundamental laws or principles apply to the solution of this problem, especially before applying any mathematical techniques.
- Devise a thought experiment to explore the characteristics of the problem scenario, applying known laws and principles to mentally model its behavior.
- Describe in detail your own strategy for solving this problem. How did you identify and organized the given information? Did you sketch any diagrams to help frame the problem?
- Is there more than one way to solve this problem? Which method seems best to you?
- Show the work you did in solving this problem, even if the solution is incomplete or incorrect.
- What would you say was the most challenging part of this problem, and why was it so?
- Was any important information missing from the problem which you had to research or recall?
- Was there any extraneous information presented within this problem? If so, what was it and why did it not matter?
- Examine someone else's solution to identify where they applied fundamental laws or principles.
- Simplify the problem from its given form and show how to solve this simpler version of it. Examples include eliminating certain variables or conditions, altering values to simpler (usually whole) numbers, applying a limiting case (i.e. altering a variable to some extreme or ultimate value).
- For quantitative problems, identify the real-world meaning of all intermediate calculations: their units of measurement, where they fit into the scenario at hand. Annotate any diagrams or illustrations with these calculated values.
- For quantitative problems, try approaching it qualitatively instead, thinking in terms of “increase” and “decrease” rather than definite values.
- For qualitative problems, try approaching it quantitatively instead, proposing simple numerical values for the variables.
- Were there any assumptions you made while solving this problem? Would your solution change if one of those assumptions were altered?
- Identify where it would be easy for someone to go astray in attempting to solve this problem.
- Formulate your own problem based on what you learned solving this one.

GENERAL FOLLOW-UP CHALLENGES FOR EXPERIMENTS OR PROJECTS

- In what way(s) was this experiment or project easy to complete?
- Identify some of the challenges you faced in completing this experiment or project.

- Show how thorough documentation assisted in the completion of this experiment or project.
- Which fundamental laws or principles are key to this system's function?
- Identify any way(s) in which one might obtain false or otherwise misleading measurements from test equipment in this system.
- What will happen if (component X) fails (open/shorted/etc.)?
- What would have to occur to make this system unsafe?

7.1 Conceptual reasoning

These questions are designed to stimulate your analytic and synthetic thinking³. In a Socratic discussion with your instructor, the goal is for these questions to prompt an extended dialogue where assumptions are revealed, conclusions are tested, and understanding is sharpened. Your instructor may also pose additional questions based on those assigned, in order to further probe and refine your conceptual understanding.

Questions that follow are presented to challenge and probe your understanding of various concepts presented in the tutorial. These questions are intended to serve as a guide for the Socratic dialogue between yourself and the instructor. Your instructor’s task is to ensure you have a sound grasp of these concepts, and the questions contained in this document are merely a means to this end. Your instructor may, at his or her discretion, alter or substitute questions for the benefit of tailoring the discussion to each student’s needs. The only absolute requirement is that each student is challenged and assessed at a level equal to or greater than that represented by the documented questions.

It is far more important that you convey your *reasoning* than it is to simply convey a correct answer. For this reason, you should refrain from researching other information sources to answer questions. What matters here is that *you* are doing the thinking. If the answer is incorrect, your instructor will work with you to correct it through proper reasoning. A correct answer without an adequate explanation of how you derived that answer is unacceptable, as it does not aid the learning or assessment process.

You will note a conspicuous lack of answers given for these conceptual questions. Unlike standard textbooks where answers to every other question are given somewhere toward the back of the book, here in these learning modules students must rely on other means to check their work. The best way by far is to debate the answers with fellow students and also with the instructor during the Socratic dialogue sessions intended to be used with these learning modules. Reasoning through challenging questions with other people is an excellent tool for developing strong reasoning skills.

Another means of checking your conceptual answers, where applicable, is to use circuit simulation software to explore the effects of changes made to circuits. For example, if one of these conceptual questions challenges you to predict the effects of altering some component parameter in a circuit, you may check the validity of your work by simulating that same parameter change within software and seeing if the results agree.

³*Analytical* thinking involves the “disassembly” of an idea into its constituent parts, analogous to dissection. *Synthetic* thinking involves the “assembly” of a new idea comprised of multiple concepts, analogous to construction. Both activities are high-level cognitive skills, extremely important for effective problem-solving, necessitating frequent challenge and regular practice to fully develop.

7.1.1 Reading outline and reflections

“Reading maketh a full man; conference a ready man; and writing an exact man” – Francis Bacon

Francis Bacon’s advice is a blueprint for effective education: reading provides the learner with knowledge, writing focuses the learner’s thoughts, and critical dialogue equips the learner to confidently communicate and apply their learning. Independent acquisition and application of knowledge is a powerful skill, well worth the effort to cultivate. To this end, students should read these educational resources closely, journal their own reflections on the reading, and discuss in detail their findings with classmates and instructor(s). You should be able to do all of the following after reading any instructional text:

☑ Briefly **SUMMARIZE THE TEXT** in the form of a journal entry documenting your learning as you progress through the course of study. Share this summary in dialogue with your classmates and instructor. Journaling is an excellent self-test of thorough reading because you cannot clearly express what you have not read or did not comprehend.

☑ Demonstrate **ACTIVE READING STRATEGIES**, including verbalizing your impressions as you read, simplifying long passages to convey the same ideas using fewer words, annotating text and illustrations with your own interpretations, working through mathematical examples shown in the text, cross-referencing passages with relevant illustrations and/or other passages, identifying problem-solving strategies applied by the author, etc. Technical reading is a special case of problem-solving, and so these strategies work precisely because they help solve any problem: paying attention to your own thoughts (metacognition), eliminating unnecessary complexities, identifying what makes sense, paying close attention to details, drawing connections between separated facts, and noting the successful strategies of others.

☑ Identify **IMPORTANT THEMES**, especially **GENERAL LAWS** and **PRINCIPLES**, expounded in the text and express them in the simplest of terms as though you were teaching an intelligent child. This emphasizes connections between related topics and develops your ability to communicate complex ideas to anyone.

☑ Form **YOUR OWN QUESTIONS** based on the reading, and then pose them to your instructor and classmates for their consideration. Anticipate both correct and incorrect answers, the incorrect answer(s) assuming one or more plausible misconceptions. This helps you view the subject from different perspectives to grasp it more fully.

☑ Devise **EXPERIMENTS** to test claims presented in the reading, or to disprove misconceptions. Predict possible outcomes of these experiments, and evaluate their meanings: what result(s) would confirm, and what would constitute disproof? Running mental simulations and evaluating results is essential to scientific and diagnostic reasoning.

☑ Specifically identify any points you found **CONFUSING**. The reason for doing this is to help diagnose misconceptions and overcome barriers to learning.

7.1.2 Foundational concepts

Correct analysis and diagnosis of electric circuits begins with a proper understanding of some basic concepts. The following is a list of some important concepts referenced in this module's full tutorial. Define each of them in your own words, and be prepared to illustrate each of these concepts with a description of a practical example and/or a live demonstration.

Energy

Conservation of Energy

Electromagnetism

Electromagnetic induction

Faraday's Law of electromagnetic induction

Self-induction

Mutual induction

Electrical source

Electrical load

Transformer

Primary winding

Secondary winding

Turns ratio

Winding tap

Apparent power

Transformer impedance

Potential transformer (PT)

Current transformer (CT)

7.1.3 Gaulard and Gibbs transformer

In 1884 two inventors named Gaulard and Gibbs invented a transformer to be used for electric lighting purposes, stepping voltage down from the output of an AC generator to lower levels suitable for operating electric lamps. Its construction is shown in the following diagram taken from page 79 of *The Alternating Current Transformer in Theory and Practice* by John Ambrose Fleming (published in 1892):

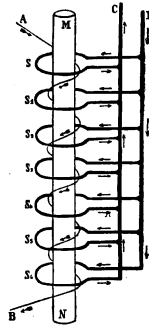

Identify the primary and secondary windings of this transformer.

Identify the turns ratio of this transformer as shown.

Challenges

- What feature(s) of this illustration reveal which winding is designed to carry high current and which winding is designed to carry low current?

7.1.4 Leakage inductance

Examine this illustration, taken from page 107 of *The Alternating Current Transformer in Theory and Practice* by J.A Fleming (published in 1892), showing the basis of *magnetic leakage* in a transformer:

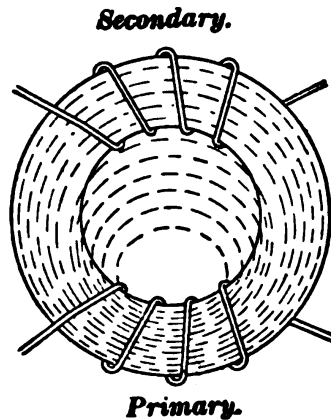

FIG. 66.—Diagram illustrating Magnetic Leakage in a Transformer.

Why are all the magnetic lines of flux passing through the primary winding but not all pass through the secondary winding?

Identify the ideal voltage “step” ratio of this transformer.

What effect will this leakage flux have on the voltage “step” ratio of the transformer?

Challenges

- A good problem-solving technique to apply to this problem is *limiting cases*, where you assess the behavior of a system given some exaggeration of the variable at hand. Here the variable being considered is flux leakage. Describe both a “high” and a “low” limiting case for this leakage, as well as how the transformer would behave in each of these cases.

7.1.5 Explaining the meaning of calculations

An unfortunate tendency among beginning students in any quantitative discipline is to perform calculations without regard for the real-world meanings of the values, and also to follow mathematical formulae without considering the general principles embodied in each. To ignore concepts while performing calculations is a serious error for a variety of reasons, not the least of which being an increased likelihood of computing results that turn out to be nonsense.

In the spirit of honoring concepts, I present to you a quantitative problem where all the calculations have been done for you, but all variable labels, units, and other identifying data have been stripped away. Your task is to *assign proper meaning* to each of the numbers, identify the correct unit of measurement in each case, apply any appropriate metric prefixes to those values, explain the significance of each value by describing where it “fits” into the circuit being analyzed, and identify the general principle employed at each step.

Here is the schematic diagram of the transformer circuit:

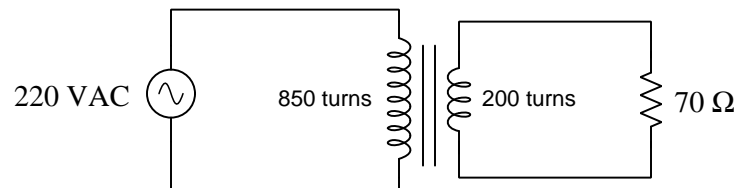

Here are all the calculations performed in order from first to last:

1. $\frac{850}{200} = 4.25$
2. $\frac{220}{4.25} = 51.765$
3. $\frac{51.765}{70} = 739.5 \times 10^{-3}$
4. $\frac{739.5 \times 10^{-3}}{4.25} = 174.0 \times 10^{-3}$
5. $(220)(174.0 \times 10^{-3}) = 38.280$
6. $(51.765)(739.5 \times 10^{-3}) = 38.280$

Explain what each value means in the circuit, identify its unit of measurement and appropriate metric prefix, and identify the general principle used to compute it!

Challenges

- Explain how you can check your own thinking as you solve quantitative problems, to avoid the dilemma of just “crunching numbers” to get an answer.
- For each calculated step shown, identify the physical Law or electric circuit principle being applied.
- Identify any of the calculations shown above whose order could be changed. In other words, can this problem be solved in a different order?
- Identify any of the calculations shown above that are not strictly necessary to the complete analysis of the circuit, explaining why it has any merit at all.
- Do you see any alternative paths to a solution, involving specific calculations not shown above?
- When performing addition or subtraction on physical quantities, all units of measurement must be identical. Identify where you see this principle being applied in the steps above.

7.1.6 Industrial control power transformer

Industrial *control power transformers* are used to step down 480 or 240 Volts to a level more acceptable for relay control circuitry: usually 120 Volts. Some control power transformers are built with multiple primary windings, to facilitate connection to either a 480 Volt or 240 Volt AC power source:

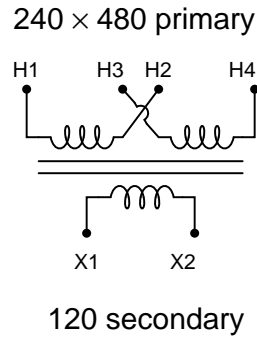

Such transformers are usually advertised as having “240 × 480” primary windings, the “×” symbol representing two independent windings with four connection points (H1 through H4).

Show the connections on the four “H” terminals necessary for 240 Volt operation, and also for 480 Volt operation, on the following illustrations:

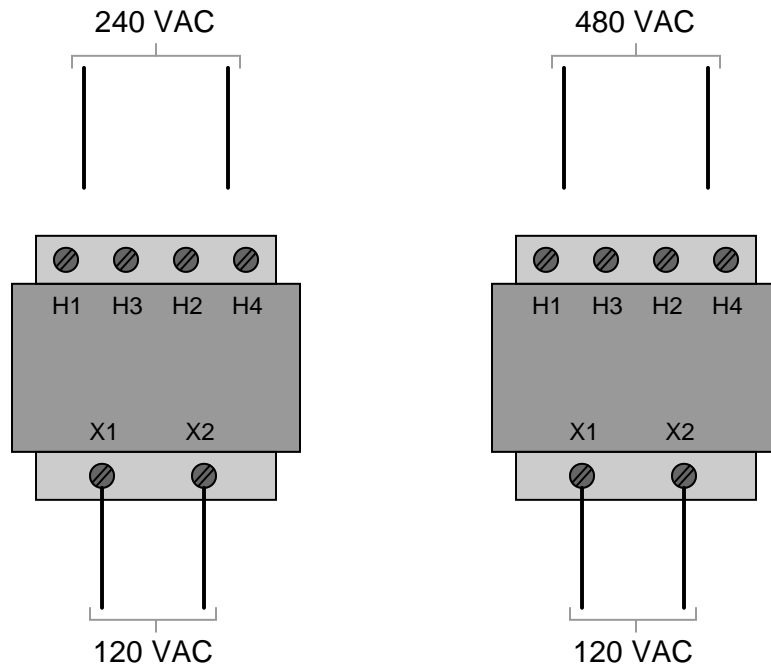

Challenges

- Identify how the concepts of series and parallel networks relates directly to this application.
- Is it possible to use just one of the two primary windings, and still have the transformer be functional?

7.1.7 Boost/buck transformer circuits

Identify which of these transformer circuits will *boost* voltage to the load, and which will *buck* voltage to the load, annotating each winding of the transformer as well as the load with + and – polarity marks (denoting actual voltage polarity at some instant in time):

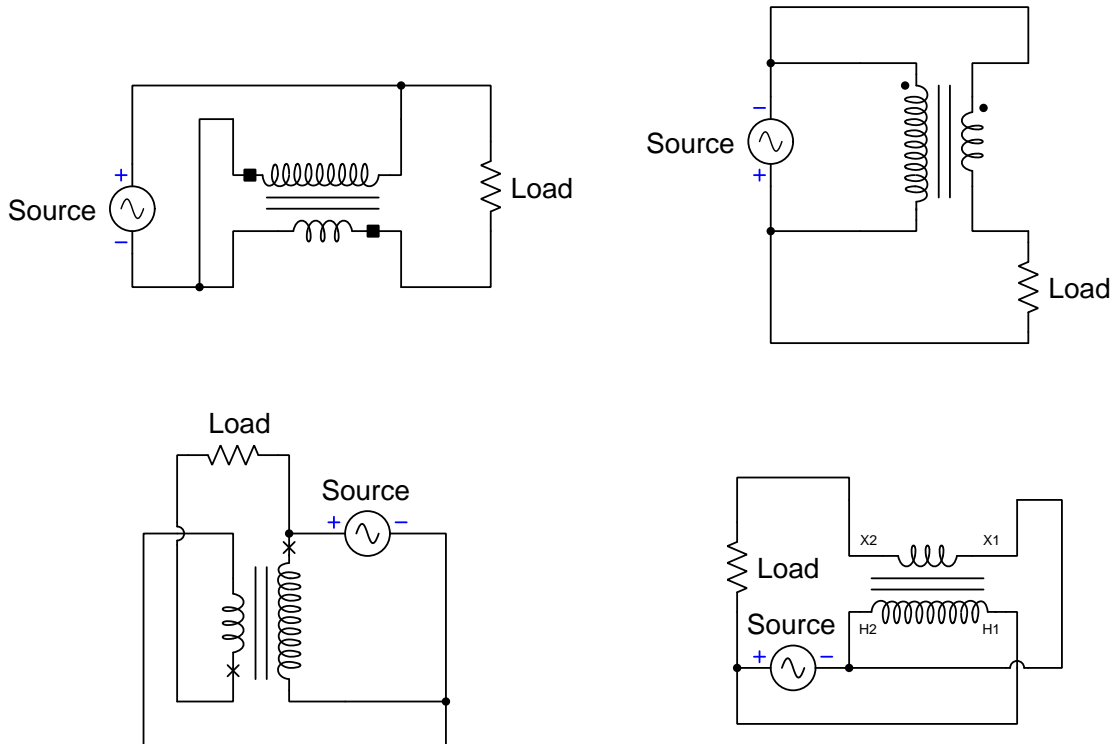

Challenges

- A profitable problem-solving strategy for many conceptual or qualitative problems is to add some numerical quantities to it. Try that with this problem, and explain how this extra information may be helpful to finding the solution.
- After adding some numerical values, calculate the amount and direction of current through each of the transformer's windings. You should notice something very interesting!

7.1.8 Multi-wire secondary connections

A power transformer has three large conductors exiting its secondary-winding side, two of those large conductors consisting (each) of three smaller winding wires joined together while the center conductor is made of the union of six smaller winding wires, like this:

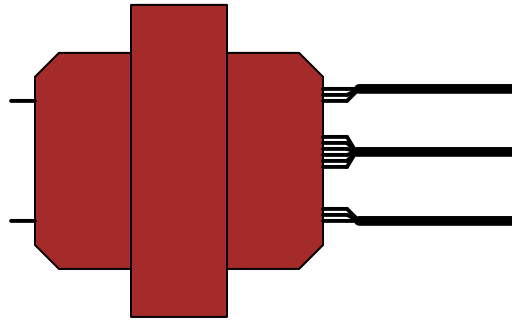

Explain why these large secondary conductors join to smaller conductors that actually make up the transformer's secondary windings (coils). How exactly is the secondary of this transformer wound?

Challenges

- Show how to re-wire this transformer so that it no longer has a center-tap.

7.2 Quantitative reasoning

These questions are designed to stimulate your computational thinking. In a Socratic discussion with your instructor, the goal is for these questions to reveal your mathematical approach(es) to problem-solving so that good technique and sound reasoning may be reinforced. Your instructor may also pose additional questions based on those assigned, in order to observe your problem-solving firsthand.

Mental arithmetic and estimations are strongly encouraged for all calculations, because without these abilities you will be unable to readily detect errors caused by calculator misuse (e.g. keystroke errors).

You will note a conspicuous lack of answers given for these quantitative questions. Unlike standard textbooks where answers to every other question are given somewhere toward the back of the book, here in these learning modules students must rely on other means to check their work. My advice is to use circuit simulation software such as SPICE to check the correctness of quantitative answers. Refer to those learning modules within this collection focusing on SPICE to see worked examples which you may use directly as practice problems for your own study, and/or as templates you may modify to run your own analyses and generate your own practice problems.

Completely worked example problems found in the Tutorial may also serve as “test cases⁴” for gaining proficiency in the use of circuit simulation software, and then once that proficiency is gained you will never need to rely⁵ on an answer key!

⁴In other words, set up the circuit simulation software to analyze the same circuit examples found in the Tutorial. If the simulated results match the answers shown in the Tutorial, it confirms the simulation has properly run. If the simulated results disagree with the Tutorial’s answers, something has been set up incorrectly in the simulation software. Using every Tutorial as practice in this way will quickly develop proficiency in the use of circuit simulation software.

⁵This approach is perfectly in keeping with the instructional philosophy of these learning modules: *teaching students to be self-sufficient thinkers*. Answer keys can be useful, but it is even more useful to your long-term success to have a set of tools on hand for checking your own work, because once you have left school and are on your own, there will no longer be “answer keys” available for the problems you will have to solve.

7.2.1 Miscellaneous physical constants

Note: constants shown in **bold** type are *exact*, not approximations. Values inside of parentheses show one standard deviation (σ) of uncertainty in the final digits: for example, the magnetic permeability of free space value given as $1.25663706212(19) \times 10^{-6}$ H/m represents a center value (i.e. the location parameter) of $1.25663706212 \times 10^{-6}$ Henrys per meter with one standard deviation of uncertainty equal to $0.0000000000019 \times 10^{-6}$ Henrys per meter.

Avogadro's number (N_A) = **6.02214076** $\times 10^{23}$ **per mole** (mol⁻¹)

Boltzmann's constant (k) = **1.380649** $\times 10^{-23}$ **Joules per Kelvin** (J/K)

Electronic charge (e) = **1.602176634** $\times 10^{-19}$ **Coulomb** (C)

Faraday constant (F) = **96,485.33212...** $\times 10^4$ **Coulombs per mole** (C/mol)

Magnetic permeability of free space (μ_0) = $1.25663706212(19) \times 10^{-6}$ Henrys per meter (H/m)

Electric permittivity of free space (ϵ_0) = $8.8541878128(13) \times 10^{-12}$ Farads per meter (F/m)

Characteristic impedance of free space (Z_0) = $376.730313668(57)$ Ohms (Ω)

Gravitational constant (G) = $6.67430(15) \times 10^{-11}$ cubic meters per kilogram-seconds squared (m³/kg-s²)

Molar gas constant (R) = **8.314462618...** **Joules per mole-Kelvin** (J/mol-K) = 0.08205746(14) liters-atmospheres per mole-Kelvin

Planck constant (h) = **6.62607015** $\times 10^{-34}$ **joule-seconds** (J-s)

Stefan-Boltzmann constant (σ) = **5.670374419...** $\times 10^{-8}$ **Watts per square meter-Kelvin⁴** (W/m²·K⁴)

Speed of light in a vacuum (c) = **299,792,458 meters per second** (m/s) = 186282.4 miles per second (mi/s)

Note: All constants taken from NIST data "Fundamental Physical Constants – Complete Listing", from <http://physics.nist.gov/constants>, National Institute of Standards and Technology (NIST), 2018 CODATA Adjustment.

7.2.2 Introduction to spreadsheets

A powerful computational tool you are encouraged to use in your work is a *spreadsheet*. Available on most personal computers (e.g. Microsoft Excel), *spreadsheet* software performs numerical calculations based on number values and formulae entered into cells of a grid. This grid is typically arranged as lettered columns and numbered rows, with each cell of the grid identified by its column/row coordinates (e.g. cell B3, cell A8). Each cell may contain a string of text, a number value, or a mathematical formula. The spreadsheet automatically updates the results of all mathematical formulae whenever the entered number values are changed. This means it is possible to set up a spreadsheet to perform a series of calculations on entered data, and those calculations will be re-done by the computer any time the data points are edited in any way.

For example, the following spreadsheet calculates average speed based on entered values of distance traveled and time elapsed:

	A	B	C	D
1	Distance traveled	46.9	Kilometers	
2	Time elapsed	1.18	Hours	
3	Average speed	= B1 / B2	km/h	
4				
5				

Text labels contained in cells A1 through A3 and cells C1 through C3 exist solely for readability and are not involved in any calculations. Cell B1 contains a sample distance value while cell B2 contains a sample time value. The formula for computing speed is contained in cell B3. Note how this formula begins with an “equals” symbol (=), references the values for distance and speed by lettered column and numbered row coordinates (B1 and B2), and uses a forward slash symbol for division (/). The coordinates B1 and B2 function as *variables*⁶ would in an algebraic formula.

When this spreadsheet is executed, the numerical value 39.74576 will appear in cell B3 rather than the formula = B1 / B2, because 39.74576 is the computed speed value given 46.9 kilometers traveled over a period of 1.18 hours. If a different numerical value for distance is entered into cell B1 or a different value for time is entered into cell B2, cell B3’s value will automatically update. All you need to do is set up the given values and any formulae into the spreadsheet, and the computer will do all the calculations for you.

Cell B3 may be referenced by other formulae in the spreadsheet if desired, since it is a variable just like the given values contained in B1 and B2. This means it is possible to set up an entire chain of calculations, one dependent on the result of another, in order to arrive at a final value. The arrangement of the given data and formulae need not follow any pattern on the grid, which means you may place them anywhere.

⁶Spreadsheets may also provide means to attach text labels to cells for use as variable names (Microsoft Excel simply calls these labels “names”), but for simple spreadsheets such as those shown here it’s usually easier just to use the standard coordinate naming for each cell.

Common⁷ arithmetic operations available for your use in a spreadsheet include the following:

- Addition (+)
- Subtraction (-)
- Multiplication (*)
- Division (/)
- Powers (^)
- Square roots (sqrt())
- Logarithms (ln() , log10())

Parentheses may be used to ensure⁸ proper order of operations within a complex formula. Consider this example of a spreadsheet implementing the *quadratic formula*, used to solve for roots of a polynomial expression in the form of $ax^2 + bx + c$:

$$x = \frac{-b \pm \sqrt{b^2 - 4ac}}{2a}$$

	A	B
1	x_1	= (-B4 + sqrt((B4^2) - (4*B3*B5))) / (2*B3)
2	x_2	= (-B4 - sqrt((B4^2) - (4*B3*B5))) / (2*B3)
3	a =	9
4	b =	5
5	c =	-2

This example is configured to compute roots⁹ of the polynomial $9x^2 + 5x - 2$ because the values of 9, 5, and -2 have been inserted into cells B3, B4, and B5, respectively. Once this spreadsheet has been built, though, it may be used to calculate the roots of *any* second-degree polynomial expression simply by entering the new a , b , and c coefficients into cells B3 through B5. The numerical values appearing in cells B1 and B2 will be automatically updated by the computer immediately following any changes made to the coefficients.

⁷Modern spreadsheet software offers a bewildering array of mathematical functions you may use in your computations. I recommend you consult the documentation for your particular spreadsheet for information on operations other than those listed here.

⁸Spreadsheet programs, like text-based programming languages, are designed to follow standard order of operations by default. However, my personal preference is to use parentheses even where strictly unnecessary just to make it clear to any other person viewing the formula what the intended order of operations is.

⁹Reviewing some algebra here, a *root* is a value for x that yields an overall value of zero for the polynomial. For this polynomial ($9x^2 + 5x - 2$) the two roots happen to be $x = 0.269381$ and $x = -0.82494$, with these values displayed in cells B1 and B2, respectively upon execution of the spreadsheet.

Alternatively, one could break up the long quadratic formula into smaller pieces like this:

$$y = \sqrt{b^2 - 4ac} \quad z = 2a$$

$$x = \frac{-b \pm y}{z}$$

	A	B	C
1	x_1	= (-B4 + C1) / C2	= sqrt((B4^2) - (4*B3*B5))
2	x_2	= (-B4 - C1) / C2	= 2*B3
3	a =	9	
4	b =	5	
5	c =	-2	

Note how the square-root term (y) is calculated in cell C1, and the denominator term (z) in cell C2. This makes the two final formulae (in cells B1 and B2) simpler to interpret. The positioning of all these cells on the grid is completely arbitrary¹⁰ – all that matters is that they properly reference each other in the formulae.

Spreadsheets are particularly useful for situations where the same set of calculations representing a circuit or other system must be repeated for different initial conditions. The power of a spreadsheet is that it automates what would otherwise be a tedious set of calculations. One specific application of this is to simulate the effects of various components within a circuit failing with abnormal values (e.g. a shorted resistor simulated by making its value nearly zero; an open resistor simulated by making its value extremely large). Another application is analyzing the behavior of a circuit design given new components that are out of specification, and/or aging components experiencing drift over time.

¹⁰My personal preference is to locate all the “given” data in the upper-left cells of the spreadsheet grid (each data point flanked by a sensible name in the cell to the left and units of measurement in the cell to the right as illustrated in the first distance/time spreadsheet example), sometimes coloring them in order to clearly distinguish which cells contain entered data versus which cells contain computed results from formulae. I like to place all formulae in cells below the given data, and try to arrange them in logical order so that anyone examining my spreadsheet will be able to figure out *how* I constructed a solution. This is a general principle I believe all computer programmers should follow: *document and arrange your code to make it easy for other people to learn from it.*

7.2.3 Basic transformer calculations

Calculate the load current and load voltage in this transformer circuit:

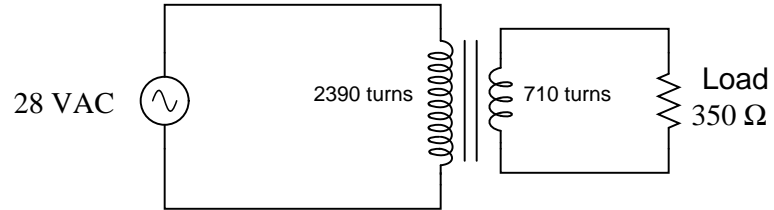

Calculate all winding voltages and currents in this transformer circuit:

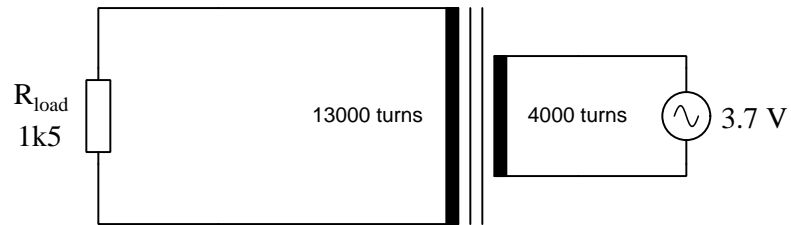

Calculate all unlabeled voltages and currents in this transformer circuit:

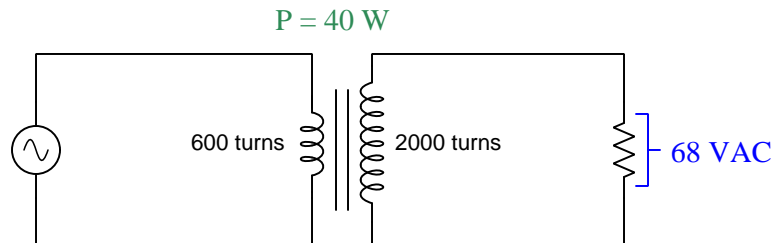

Calculate all winding voltages and currents in this transformer circuit:

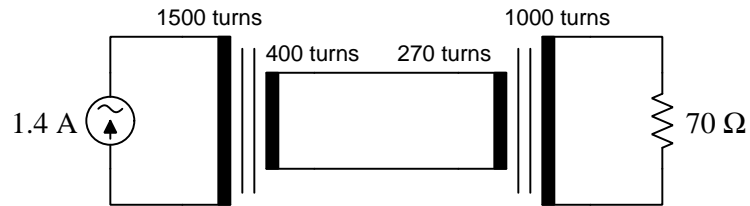

Lastly, explain why all of these transformer examples show whole-numbered turns values. Why is it physically impossible to create a transformer winding with a partial number of turns (e.g. 240.7 turns)?

Challenges

- Which of these transformers is operating in *step-up* mode, and which is operating in *step-down* mode?
- Do the two different symbol types mean anything for the purpose or characteristics of each transformer?
- Identify the effects of a *partially-shortened winding* (i.e. where some of the turns within a winding are shorted past by an unintentional connection) for either winding of either transformer.

7.2.4 Autotransformer currents

Calculate all currents in this autotransformer circuit, assuming perfect (100%) efficiency:

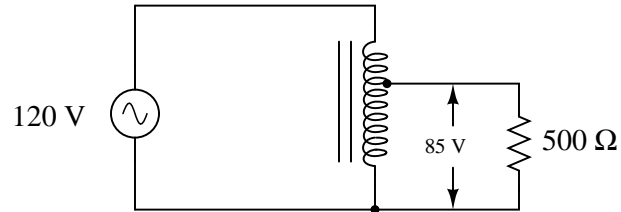

Challenges

- Based on these current figures, what economic advantage does an autotransformer have over a conventional transformer in terms of manufacturing cost?
- Autotransformers lack the electrical *isolation* provided by a normal transformer. Explain what the term “isolation” means in this context, and why it might be useful or even necessary.

7.2.5 Transformer-resistor circuit

Calculate all voltages and all currents in this transformer circuit, assuming the $3.3\text{ k}\Omega$ resistor drops 13 Volts:

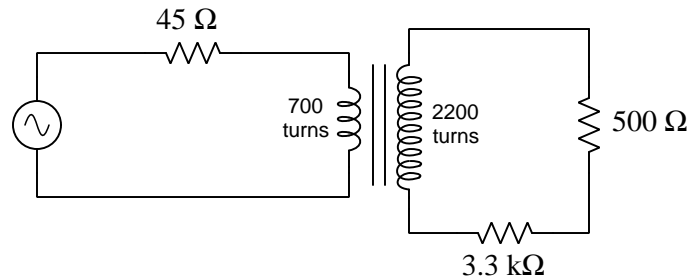

- $V_{source} =$
- $V_{primary} =$
- $V_{secondary} =$
- $I_{source} =$
- $I_{primary} =$
- $I_{secondary} =$

Challenges

- Suppose the $3.3\ \text{k}\Omega$ resistor failed open. How would this affect the other voltages and currents, assuming the same source voltage as before?
- Suppose the source voltage remained unchanged, but the $500\ \Omega$ resistor was removed from the circuit and replaced by a “jumper” wire. How would the other voltages and currents be affected?

7.2.6 Measuring transformer impedance

Devise a practical experimental procedure by which you could measure a power transformer’s impedance.

Challenges

- Are there any other methods available for measuring transformer impedance? If so, are they more or less practical than the method you proposed?

7.3 Diagnostic reasoning

These questions are designed to stimulate your deductive and inductive thinking, where you must apply general principles to specific scenarios (deductive) and also derive conclusions about the failed circuit from specific details (inductive). In a Socratic discussion with your instructor, the goal is for these questions to reinforce your recall and use of general circuit principles and also challenge your ability to integrate multiple symptoms into a sensible explanation of what's wrong in a circuit. Your instructor may also pose additional questions based on those assigned, in order to further challenge and sharpen your diagnostic abilities.

As always, your goal is to fully *explain* your analysis of each problem. Simply obtaining a correct answer is not good enough – you must also demonstrate sound reasoning in order to successfully complete the assignment. Your instructor's responsibility is to probe and challenge your understanding of the relevant principles and analytical processes in order to ensure you have a strong foundation upon which to build further understanding.

You will note a conspicuous lack of answers given for these diagnostic questions. Unlike standard textbooks where answers to every other question are given somewhere toward the back of the book, here in these learning modules students must rely on other means to check their work. The best way by far is to debate the answers with fellow students and also with the instructor during the Socratic dialogue sessions intended to be used with these learning modules. Reasoning through challenging questions with other people is an excellent tool for developing strong reasoning skills.

Another means of checking your diagnostic answers, where applicable, is to use circuit simulation software to explore the effects of faults placed in circuits. For example, if one of these diagnostic questions requires that you predict the effect of an open or a short in a circuit, you may check the validity of your work by simulating that same fault (substituting a very high resistance in place of that component for an open, and substituting a very low resistance for a short) within software and seeing if the results agree.

7.3.1 Faulted transformer-lamp circuit

The circuit shown here has a problem. The lamp does not light up, even though the AC power source is known to be good. You know that the circuit used to work just fine, so it is designed properly. Something in it has failed:

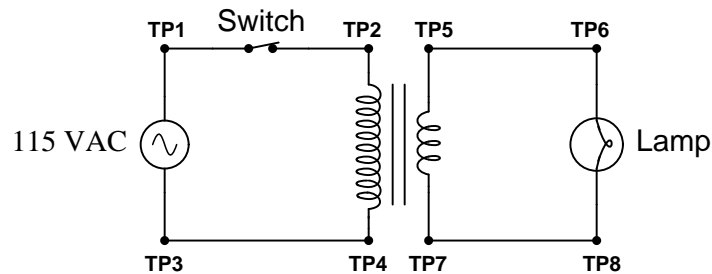

Identify one component or wire fault that could account for the lamp not lighting, and describe how you would use test equipment to verify that fault.

Challenges

- The problem states “you know that the circuit used to work just fine, so it is designed properly”. Is this necessarily true? If not, propose a counter-example.

7.3.2 Testing transformer polarity

Suppose you encounter a transformer with no polarity markings whatsoever. Devise an experiment by which you could verify the respective polarities of its windings, sketching a complete diagram here:

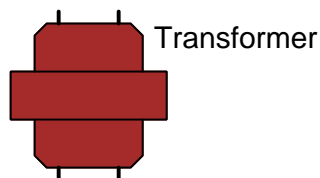

Challenges

- Where might transformer polarity be important in a functioning circuit?
- Suppose you determined this particular transformer had its “polarity” (dot) terminals on the same physical side (e.g. both right-hand terminals “dotted”). Would this be an “additive” or a “subtractive” transformer?

Appendix A

Problem-Solving Strategies

The ability to solve complex problems is arguably one of the most valuable skills one can possess, and this skill is particularly important in any science-based discipline.

- Study principles, not procedures. Don't be satisfied with merely knowing how to compute solutions – learn *why* those solutions work.
- Identify what it is you need to solve, identify all relevant data, identify all units of measurement, identify any general principles or formulae linking the given information to the solution, and then identify any “missing pieces” to a solution. Annotate all diagrams with this data.
- Sketch a diagram to help visualize the problem. When building a real system, always devise a plan for that system and analyze its function *before* constructing it.
- Follow the units of measurement and meaning of every calculation. If you are ever performing mathematical calculations as part of a problem-solving procedure, and you find yourself unable to apply each and every intermediate result to some aspect of the problem, it means you don't understand what you are doing. Properly done, every mathematical result should have practical meaning for the problem, and not just be an abstract number. You should be able to identify the proper units of measurement for each and every calculated result, and show where that result fits into the problem.
- Perform “thought experiments” to explore the effects of different conditions for theoretical problems. When troubleshooting real systems, perform *diagnostic tests* rather than visually inspecting for faults, the best diagnostic test being the one giving you the most information about the nature and/or location of the fault with the fewest steps.
- Simplify the problem until the solution becomes obvious, and then use that obvious case as a model to follow in solving the more complex version of the problem.
- Check for exceptions to see if your solution is incorrect or incomplete. A good solution will work for *all* known conditions and criteria. A good example of this is the process of testing scientific hypotheses: the task of a scientist is not to find support for a new idea, but rather to *challenge* that new idea to see if it holds up under a battery of tests. The philosophical

principle of *reductio ad absurdum* (i.e. disproving a general idea by finding a specific case where it fails) is useful here.

- Work “backward” from a hypothetical solution to a new set of given conditions.
- Add quantities to problems that are qualitative in nature, because sometimes a little math helps illuminate the scenario.
- Sketch graphs illustrating how variables relate to each other. These may be quantitative (i.e. with realistic number values) or qualitative (i.e. simply showing increases and decreases).
- Treat quantitative problems as qualitative in order to discern the relative magnitudes and/or directions of change of the relevant variables. For example, try determining what happens if a certain variable were to increase or decrease before attempting to precisely calculate quantities: how will each of the dependent variables respond, by increasing, decreasing, or remaining the same as before?
- Consider limiting cases. This works especially well for qualitative problems where you need to determine which direction a variable will change. Take the given condition and magnify that condition to an extreme degree as a way of simplifying the direction of the system’s response.
- Check your work. This means regularly testing your conclusions to see if they make sense. This does *not* mean repeating the same steps originally used to obtain the conclusion(s), but rather to use some other means to check validity. Simply repeating procedures often leads to *repeating the same errors* if any were made, which is why alternative paths are better.

Appendix B

Instructional philosophy

“The unexamined circuit is not worth energizing” – Socrates (if he had taught electricity)

These learning modules, although useful for self-study, were designed to be used in a formal learning environment where a subject-matter expert challenges students to digest the content and exercise their critical thinking abilities in the answering of questions and in the construction and testing of working circuits.

The following principles inform the instructional and assessment philosophies embodied in these learning modules:

- The first goal of education is to enhance clear and independent thought, in order that every student reach their fullest potential in a highly complex and inter-dependent world. Robust reasoning is *always* more important than particulars of any subject matter, because its application is universal.
- Literacy is fundamental to independent learning and thought because text continues to be the most efficient way to communicate complex ideas over space and time. Those who cannot read with ease are limited in their ability to acquire knowledge and perspective.
- Articulate communication is fundamental to work that is complex and interdisciplinary.
- Faulty assumptions and poor reasoning are best corrected through challenge, not presentation. The rhetorical technique of *reductio ad absurdum* (disproving an assertion by exposing an absurdity) works well to discipline student’s minds, not only to correct the problem at hand but also to learn how to detect and correct future errors.
- Important principles should be repeatedly explored and widely applied throughout a course of study, not only to reinforce their importance and help ensure their mastery, but also to showcase the interconnectedness and utility of knowledge.

These learning modules were expressly designed to be used in an “inverted” teaching environment¹ where students first read the introductory and tutorial chapters on their own, then individually attempt to answer the questions and construct working circuits according to the experiment and project guidelines. The instructor never lectures, but instead meets regularly with each individual student to review their progress, answer questions, identify misconceptions, and challenge the student to new depths of understanding through further questioning. Regular meetings between instructor and student should resemble a Socratic² dialogue, where questions serve as scalpels to dissect topics and expose assumptions. The student passes each module only after consistently demonstrating their ability to logically analyze and correctly apply all major concepts in each question or project/experiment. The instructor must be vigilant in probing each student’s understanding to ensure they are truly *reasoning* and not just *memorizing*. This is why “Challenge” points appear throughout, as prompts for students to think deeper about topics and as starting points for instructor queries. Sometimes these challenge points require additional knowledge that hasn’t been covered in the series to answer in full. This is okay, as the major purpose of the Challenges is to stimulate analysis and synthesis on the part of each student.

The instructor must possess enough mastery of the subject matter and awareness of students’ reasoning to generate their own follow-up questions to practically any student response. Even completely correct answers given by the student should be challenged by the instructor for the purpose of having students practice articulating their thoughts and defending their reasoning. Conceptual errors committed by the student should be exposed and corrected not by direct instruction, but rather by reducing the errors to an absurdity³ through well-chosen questions and thought experiments posed by the instructor. Becoming proficient at this style of instruction requires time and dedication, but the positive effects on critical thinking for both student and instructor are spectacular.

An inspection of these learning modules reveals certain unique characteristics. One of these is a bias toward thorough explanations in the tutorial chapters. Without a live instructor to explain concepts and applications to students, the text itself must fulfill this role. This philosophy results in lengthier explanations than what you might typically find in a textbook, each step of the reasoning process fully explained, including footnotes addressing common questions and concerns students raise while learning these concepts. Each tutorial seeks to not only explain each major concept in sufficient detail, but also to explain the logic of each concept and how each may be developed

¹In a traditional teaching environment, students first encounter new information via *lecture* from an expert, and then independently apply that information via *homework*. In an “inverted” course of study, students first encounter new information via *homework*, and then independently apply that information under the scrutiny of an expert. The expert’s role in lecture is to simply *explain*, but the expert’s role in an inverted session is to *challenge, critique*, and if necessary *explain* where gaps in understanding still exist.

²Socrates is a figure in ancient Greek philosophy famous for his unflinching style of questioning. Although he authored no texts, he appears as a character in Plato’s many writings. The essence of Socratic philosophy is to leave no question unexamined and no point of view unchallenged. While purists may argue a topic such as electric circuits is too narrow for a true Socratic-style dialogue, I would argue that the essential thought processes involved with scientific reasoning on *any* topic are not far removed from the Socratic ideal, and that students of electricity and electronics would do very well to challenge assumptions, pose thought experiments, identify fallacies, and otherwise employ the arsenal of critical thinking skills modeled by Socrates.

³This rhetorical technique is known by the Latin phrase *reductio ad absurdum*. The concept is to expose errors by counter-example, since only one solid counter-example is necessary to disprove a universal claim. As an example of this, consider the common misconception among beginning students of electricity that voltage cannot exist without current. One way to apply *reductio ad absurdum* to this statement is to ask how much current passes through a fully-charged battery connected to nothing (i.e. a clear example of voltage existing without current).

from “first principles”. Again, this reflects the goal of developing clear and independent thought in students’ minds, by showing how clear and logical thought was used to forge each concept. Students benefit from witnessing a model of clear thinking in action, and these tutorials strive to be just that.

Another characteristic of these learning modules is a lack of step-by-step instructions in the Project and Experiment chapters. Unlike many modern workbooks and laboratory guides where step-by-step instructions are prescribed for each experiment, these modules take the approach that students must learn to closely read the tutorials and apply their own reasoning to identify the appropriate experimental steps. Sometimes these steps are plainly declared in the text, just not as a set of enumerated points. At other times certain steps are implied, an example being assumed competence in test equipment use where the student should not need to be told *again* how to use their multimeter because that was thoroughly explained in previous lessons. In some circumstances no steps are given at all, leaving the entire procedure up to the student.

This lack of prescription is not a flaw, but rather a feature. Close reading and clear thinking are foundational principles of this learning series, and in keeping with this philosophy all activities are designed to *require* those behaviors. Some students may find the lack of prescription frustrating, because it demands more from them than what their previous educational experiences required. This frustration should be interpreted as an unfamiliarity with autonomous thinking, a problem which must be corrected if the student is ever to become a self-directed learner and effective problem-solver. Ultimately, the need for students to read closely and think clearly is more important both in the near-term and far-term than any specific facet of the subject matter at hand. If a student takes longer than expected to complete a module because they are forced to outline, digest, and reason on their own, so be it. The future gains enjoyed by developing this mental discipline will be well worth the additional effort and delay.

Another feature of these learning modules is that they do not treat topics in isolation. Rather, important concepts are introduced early in the series, and appear repeatedly as stepping-stones toward other concepts in subsequent modules. This helps to avoid the “compartmentalization” of knowledge, demonstrating the inter-connectedness of concepts and simultaneously reinforcing them. Each module is fairly complete in itself, reserving the beginning of its tutorial to a review of foundational concepts.

This methodology of assigning text-based modules to students for digestion and then using Socratic dialogue to assess progress and hone students’ thinking was developed over a period of several years by the author with his Electronics and Instrumentation students at the two-year college level. While decidedly unconventional and sometimes even unsettling for students accustomed to a more passive lecture environment, this instructional philosophy has proven its ability to convey conceptual mastery, foster careful analysis, and enhance employability so much better than lecture that the author refuses to ever teach by lecture again.

Problems which often go undiagnosed in a lecture environment are laid bare in this “inverted” format where students must articulate and logically defend their reasoning. This, too, may be unsettling for students accustomed to lecture sessions where the instructor cannot tell for sure who comprehends and who does not, and this vulnerability necessitates sensitivity on the part of the “inverted” session instructor in order that students never feel discouraged by having their errors exposed. *Everyone* makes mistakes from time to time, and learning is a lifelong process! Part of the instructor’s job is to build a culture of learning among the students where errors are not seen as shameful, but rather as opportunities for progress.

To this end, instructors managing courses based on these modules should adhere to the following principles:

- Student questions are always welcome and demand thorough, honest answers. The only type of question an instructor should refuse to answer is one the student should be able to easily answer on their own. Remember, *the fundamental goal of education is for each student to learn to think clearly and independently*. This requires hard work on the part of the student, which no instructor should ever circumvent. Anything done to bypass the student's responsibility to do that hard work ultimately limits that student's potential and thereby does real harm.
- It is not only permissible, but encouraged, to answer a student's question by asking questions in return, these follow-up questions designed to guide the student to reach a correct answer through their own reasoning.
- All student answers demand to be challenged by the instructor and/or by other students. This includes both correct and incorrect answers – the goal is to practice the articulation and defense of one's own reasoning.
- No reading assignment is deemed complete unless and until the student demonstrates their ability to accurately summarize the major points in their own terms. Recitation of the original text is unacceptable. This is why every module contains an "Outline and reflections" question as well as a "Foundational concepts" question in the Conceptual reasoning section, to prompt reflective reading.
- No assigned question is deemed answered unless and until the student demonstrates their ability to consistently and correctly apply the concepts to *variations* of that question. This is why module questions typically contain multiple "Challenges" suggesting different applications of the concept(s) as well as variations on the same theme(s). Instructors are encouraged to devise as many of their own "Challenges" as they are able, in order to have a multitude of ways ready to probe students' understanding.
- No assigned experiment or project is deemed complete unless and until the student demonstrates the task in action. If this cannot be done "live" before the instructor, video-recordings showing the demonstration are acceptable. All relevant safety precautions must be followed, all test equipment must be used correctly, and the student must be able to properly explain all results. The student must also successfully answer all Challenges presented by the instructor for that experiment or project.

Students learning from these modules would do well to abide by the following principles:

- No text should be considered fully and adequately read unless and until you can express every idea *in your own words, using your own examples*.
- You should always articulate your thoughts as you read the text, noting points of agreement, confusion, and epiphanies. Feel free to print the text on paper and then write your notes in the margins. Alternatively, keep a journal for your own reflections as you read. This is truly a helpful tool when digesting complicated concepts.
- Never take the easy path of highlighting or underlining important text. Instead, *summarize* and/or *comment* on the text using your own words. This actively engages your mind, allowing you to more clearly perceive points of confusion or misunderstanding on your own.
- A very helpful strategy when learning new concepts is to place yourself in the role of a teacher, if only as a mental exercise. Either explain what you have recently learned to someone else, or at least *imagine* yourself explaining what you have learned to someone else. The simple act of having to articulate new knowledge and skill forces you to take on a different perspective, and will help reveal weaknesses in your understanding.
- Perform each and every mathematical calculation and thought experiment shown in the text on your own, referring back to the text to see that your results agree. This may seem trivial and unnecessary, but it is critically important to ensuring you actually understand what is presented, especially when the concepts at hand are complicated and easy to misunderstand. Apply this same strategy to become proficient in the use of *circuit simulation software*, checking to see if your simulated results agree with the results shown in the text.
- Above all, recognize that learning is hard work, and that a certain level of frustration is unavoidable. There are times when you will struggle to grasp some of these concepts, and that struggle is a natural thing. Take heart that it will yield with persistent and varied⁴ effort, and never give up!

Students interested in using these modules for self-study will also find them beneficial, although the onus of responsibility for thoroughly reading and answering questions will of course lie with that individual alone. If a qualified instructor is not available to challenge students, a workable alternative is for students to form study groups where they challenge⁵ one another.

To high standards of education,

Tony R. Kuphaldt

⁴As the old saying goes, “Insanity is trying the same thing over and over again, expecting different results.” If you find yourself stumped by something in the text, you should attempt a different approach. Alter the thought experiment, change the mathematical parameters, do whatever you can to see the problem in a slightly different light, and then the solution will often present itself more readily.

⁵Avoid the temptation to simply share answers with study partners, as this is really counter-productive to learning. Always bear in mind that the answer to any question is far less important in the long run than the method(s) used to obtain that answer. The goal of education is to empower one’s life through the improvement of clear and independent thought, literacy, expression, and various practical skills.

Appendix C

Tools used

I am indebted to the developers of many open-source software applications in the creation of these learning modules. The following is a list of these applications with some commentary on each.

You will notice a theme common to many of these applications: a bias toward *code*. Although I am by no means an expert programmer in any computer language, I understand and appreciate the flexibility offered by code-based applications where the user (you) enters commands into a plain ASCII text file, which the software then reads and processes to create the final output. Code-based computer applications are by their very nature *extensible*, while WYSIWYG (What You See Is What You Get) applications are generally limited to whatever user interface the developer makes for you.

The GNU/Linux computer operating system

There is so much to be said about Linus Torvalds' `Linux` and Richard Stallman's `GNU` project. First, to credit just these two individuals is to fail to do justice to the *mob* of passionate volunteers who contributed to make this amazing software a reality. I first learned of `Linux` back in 1996, and have been using this operating system on my personal computers almost exclusively since then. It is *free*, it is completely *configurable*, and it permits the continued use of highly efficient `Unix` applications and scripting languages (e.g. shell scripts, Makefiles, `sed`, `awk`) developed over many decades. `Linux` not only provided me with a powerful computing platform, but its open design served to inspire my life's work of creating open-source educational resources.

Bram Moolenaar's Vim text editor

Writing code for any code-based computer application requires a *text editor*, which may be thought of as a word processor strictly limited to outputting plain-ASCII text files. Many good text editors exist, and one's choice of text editor seems to be a deeply personal matter within the programming world. I prefer `Vim` because it operates very similarly to `vi` which is ubiquitous on `Unix/Linux` operating systems, and because it may be entirely operated via keyboard (i.e. no mouse required) which makes it fast to use.

Donald Knuth's \TeX typesetting system

Developed in the late 1970's and early 1980's by computer scientist extraordinaire Donald Knuth to typeset his multi-volume magnum opus *The Art of Computer Programming*, this software allows the production of formatted text for screen-viewing or paper printing, all by writing plain-text code to describe how the formatted text is supposed to appear. \TeX is not just a markup language for documents, but it is also a Turing-complete programming language in and of itself, allowing useful algorithms to be created to control the production of documents. Simply put, *\TeX is a programmer's approach to word processing*. Since \TeX is controlled by code written in a plain-text file, this means anyone may read that plain-text file to see exactly how the document was created. This openness afforded by the code-based nature of \TeX makes it relatively easy to learn how other people have created their own \TeX documents. By contrast, examining a beautiful document created in a conventional WYSIWYG word processor such as Microsoft **Word** suggests nothing to the reader about *how* that document was created, or what the user might do to create something similar. As Mr. Knuth himself once quipped, conventional word processing applications should be called WYSIAYG (What You See Is *All* You Get).

Leslie Lamport's \LaTeX extensions to \TeX

Like all true programming languages, \TeX is inherently extensible. So, years after the release of \TeX to the public, Leslie Lamport decided to create a massive extension allowing easier compilation of book-length documents. The result was \LaTeX , which is the markup language used to create all ModEL module documents. You could say that \TeX is to \LaTeX as **C** is to **C++**. This means it is permissible to use any and all \TeX commands within \LaTeX source code, and it all still works. Some of the features offered by \LaTeX that would be challenging to implement in \TeX include automatic index and table-of-content creation.

Tim Edwards' **Xcircuit** drafting program

This wonderful program is what I use to create all the schematic diagrams and illustrations (but not photographic images or mathematical plots) throughout the ModEL project. It natively outputs PostScript format which is a true vector graphic format (this is why the images do not pixellate when you zoom in for a closer view), and it is so simple to use that I have never had to read the manual! Object libraries are easy to create for **Xcircuit**, being plain-text files using PostScript programming conventions. Over the years I have collected a large set of object libraries useful for drawing electrical and electronic schematics, pictorial diagrams, and other technical illustrations.

Gimp graphic image manipulation program

Essentially an open-source clone of Adobe's `PhotoShop`, I use `Gimp` to resize, crop, and convert file formats for all of the photographic images appearing in the `MODEL` modules. Although `Gimp` does offer its own scripting language (called `Script-Fu`), I have never had occasion to use it. Thus, my utilization of `Gimp` to merely crop, resize, and convert graphic images is akin to using a sword to slice bread.

SPICE circuit simulation program

`SPICE` is to circuit analysis as `TEX` is to document creation: it is a form of markup language designed to describe a certain object to be processed in plain-ASCII text. When the plain-text "source file" is compiled by the software, it outputs the final result. More modern circuit analysis tools certainly exist, but I prefer `SPICE` for the following reasons: it is *free*, it is *fast*, it is *reliable*, and it is a fantastic tool for *teaching* students of electricity and electronics how to write simple code. I happen to use rather old versions of `SPICE`, version 2g6 being my "go to" application when I only require text-based output. `NGSPICE` (version 26), which is based on Berkeley `SPICE` version 3f5, is used when I require graphical output for such things as time-domain waveforms and Bode plots. In all `SPICE` example netlists I strive to use coding conventions compatible with all `SPICE` versions.

Andrew D. Hwang's ePiX mathematical visualization programming library

This amazing project is a `C++` library you may link to any `C/C++` code for the purpose of generating PostScript graphic images of mathematical functions. As a completely free and open-source project, it does all the plotting I would otherwise use a Computer Algebra System (CAS) such as `Mathematica` or `Maple` to do. It should be said that `ePiX` is *not* a Computer Algebra System like `Mathematica` or `Maple`, but merely a mathematical *visualization* tool. In other words, it won't determine integrals for you (you'll have to implement that in your own `C/C++` code!), but it can graph the results, and it does so beautifully. What I really admire about `ePiX` is that it is a `C++` programming library, which means it builds on the existing power and toolset available with that programming language. Mr. Hwang could have probably developed his own stand-alone application for mathematical plotting, but by creating a `C++` library to do the same thing he accomplished something much greater.

`gnuplot` mathematical visualization software

Another open-source tool for mathematical visualization is `gnuplot`. Interestingly, this tool is *not* part of Richard Stallman’s GNU project, its name being a coincidence. For this reason the authors prefer “gnu” *not* be capitalized at all to avoid confusion. This is a much “lighter-weight” alternative to a spreadsheet for plotting tabular data, and the fact that it easily outputs directly to an X11 console or a file in a number of different graphical formats (including PostScript) is very helpful. I typically set my `gnuplot` output format to default (X11 on my Linux PC) for quick viewing while I’m developing a visualization, then switch to PostScript file export once the visual is ready to include in the document(s) I’m writing. As with my use of `Gimp` to do rudimentary image editing, my use of `gnuplot` only scratches the surface of its capabilities, but the important points are that it’s *free* and that it *works well*.

Python programming language

Both Python and C++ find extensive use in these modules as instructional aids and exercises, but I’m listing Python here as a *tool* for myself because I use it almost daily as a *calculator*. If you open a Python interpreter console and type `from math import *` you can type mathematical expressions and have it return results just as you would on a hand calculator. Complex-number (i.e. *phasor*) arithmetic is similarly supported if you include the complex-math library (`from cmath import *`). Examples of this are shown in the Programming References chapter (if included) in each module. Of course, being a fully-featured programming language, Python also supports conditionals, loops, and other structures useful for calculation of quantities. Also, running in a console environment where all entries and returned values show as text in a chronologically-ordered list makes it easy to copy-and-paste those calculations to document exactly how they were performed.

Appendix D

Creative Commons License

Creative Commons Attribution 4.0 International Public License

By exercising the Licensed Rights (defined below), You accept and agree to be bound by the terms and conditions of this Creative Commons Attribution 4.0 International Public License (“Public License”). To the extent this Public License may be interpreted as a contract, You are granted the Licensed Rights in consideration of Your acceptance of these terms and conditions, and the Licensor grants You such rights in consideration of benefits the Licensor receives from making the Licensed Material available under these terms and conditions.

Section 1 – Definitions.

a. **Adapted Material** means material subject to Copyright and Similar Rights that is derived from or based upon the Licensed Material and in which the Licensed Material is translated, altered, arranged, transformed, or otherwise modified in a manner requiring permission under the Copyright and Similar Rights held by the Licensor. For purposes of this Public License, where the Licensed Material is a musical work, performance, or sound recording, Adapted Material is always produced where the Licensed Material is synched in timed relation with a moving image.

b. **Adapter’s License** means the license You apply to Your Copyright and Similar Rights in Your contributions to Adapted Material in accordance with the terms and conditions of this Public License.

c. **Copyright and Similar Rights** means copyright and/or similar rights closely related to copyright including, without limitation, performance, broadcast, sound recording, and Sui Generis Database Rights, without regard to how the rights are labeled or categorized. For purposes of this Public License, the rights specified in Section 2(b)(1)-(2) are not Copyright and Similar Rights.

d. **Effective Technological Measures** means those measures that, in the absence of proper authority, may not be circumvented under laws fulfilling obligations under Article 11 of the WIPO Copyright Treaty adopted on December 20, 1996, and/or similar international agreements.

e. **Exceptions and Limitations** means fair use, fair dealing, and/or any other exception or

limitation to Copyright and Similar Rights that applies to Your use of the Licensed Material.

f. **Licensed Material** means the artistic or literary work, database, or other material to which the Licensor applied this Public License.

g. **Licensed Rights** means the rights granted to You subject to the terms and conditions of this Public License, which are limited to all Copyright and Similar Rights that apply to Your use of the Licensed Material and that the Licensor has authority to license.

h. **Licensor** means the individual(s) or entity(ies) granting rights under this Public License.

i. **Share** means to provide material to the public by any means or process that requires permission under the Licensed Rights, such as reproduction, public display, public performance, distribution, dissemination, communication, or importation, and to make material available to the public including in ways that members of the public may access the material from a place and at a time individually chosen by them.

j. **Sui Generis Database Rights** means rights other than copyright resulting from Directive 96/9/EC of the European Parliament and of the Council of 11 March 1996 on the legal protection of databases, as amended and/or succeeded, as well as other essentially equivalent rights anywhere in the world.

k. **You** means the individual or entity exercising the Licensed Rights under this Public License. **Your** has a corresponding meaning.

Section 2 – Scope.

a. License grant.

1. Subject to the terms and conditions of this Public License, the Licensor hereby grants You a worldwide, royalty-free, non-sublicensable, non-exclusive, irrevocable license to exercise the Licensed Rights in the Licensed Material to:

A. reproduce and Share the Licensed Material, in whole or in part; and

B. produce, reproduce, and Share Adapted Material.

2. Exceptions and Limitations. For the avoidance of doubt, where Exceptions and Limitations apply to Your use, this Public License does not apply, and You do not need to comply with its terms and conditions.

3. Term. The term of this Public License is specified in Section 6(a).

4. Media and formats; technical modifications allowed. The Licensor authorizes You to exercise the Licensed Rights in all media and formats whether now known or hereafter created, and to make technical modifications necessary to do so. The Licensor waives and/or agrees not to assert any right or authority to forbid You from making technical modifications necessary to exercise the Licensed Rights, including technical modifications necessary to circumvent Effective Technological Measures.

For purposes of this Public License, simply making modifications authorized by this Section 2(a)(4) never produces Adapted Material.

5. Downstream recipients.

A. Offer from the Licensor – Licensed Material. Every recipient of the Licensed Material automatically receives an offer from the Licensor to exercise the Licensed Rights under the terms and conditions of this Public License.

B. No downstream restrictions. You may not offer or impose any additional or different terms or conditions on, or apply any Effective Technological Measures to, the Licensed Material if doing so restricts exercise of the Licensed Rights by any recipient of the Licensed Material.

6. No endorsement. Nothing in this Public License constitutes or may be construed as permission to assert or imply that You are, or that Your use of the Licensed Material is, connected with, or sponsored, endorsed, or granted official status by, the Licensor or others designated to receive attribution as provided in Section 3(a)(1)(A)(i).

b. Other rights.

1. Moral rights, such as the right of integrity, are not licensed under this Public License, nor are publicity, privacy, and/or other similar personality rights; however, to the extent possible, the Licensor waives and/or agrees not to assert any such rights held by the Licensor to the limited extent necessary to allow You to exercise the Licensed Rights, but not otherwise.

2. Patent and trademark rights are not licensed under this Public License.

3. To the extent possible, the Licensor waives any right to collect royalties from You for the exercise of the Licensed Rights, whether directly or through a collecting society under any voluntary or waivable statutory or compulsory licensing scheme. In all other cases the Licensor expressly reserves any right to collect such royalties.

Section 3 – License Conditions.

Your exercise of the Licensed Rights is expressly made subject to the following conditions.

a. Attribution.

1. If You Share the Licensed Material (including in modified form), You must:

A. retain the following if it is supplied by the Licensor with the Licensed Material:

i. identification of the creator(s) of the Licensed Material and any others designated to receive attribution, in any reasonable manner requested by the Licensor (including by pseudonym if designated);

ii. a copyright notice;

- iii. a notice that refers to this Public License;
- iv. a notice that refers to the disclaimer of warranties;
- v. a URI or hyperlink to the Licensed Material to the extent reasonably practicable;

B. indicate if You modified the Licensed Material and retain an indication of any previous modifications; and

C. indicate the Licensed Material is licensed under this Public License, and include the text of, or the URI or hyperlink to, this Public License.

2. You may satisfy the conditions in Section 3(a)(1) in any reasonable manner based on the medium, means, and context in which You Share the Licensed Material. For example, it may be reasonable to satisfy the conditions by providing a URI or hyperlink to a resource that includes the required information.

3. If requested by the Licensor, You must remove any of the information required by Section 3(a)(1)(A) to the extent reasonably practicable.

4. If You Share Adapted Material You produce, the Adapter's License You apply must not prevent recipients of the Adapted Material from complying with this Public License.

Section 4 – Sui Generis Database Rights.

Where the Licensed Rights include Sui Generis Database Rights that apply to Your use of the Licensed Material:

- a. for the avoidance of doubt, Section 2(a)(1) grants You the right to extract, reuse, reproduce, and Share all or a substantial portion of the contents of the database;
- b. if You include all or a substantial portion of the database contents in a database in which You have Sui Generis Database Rights, then the database in which You have Sui Generis Database Rights (but not its individual contents) is Adapted Material; and
- c. You must comply with the conditions in Section 3(a) if You Share all or a substantial portion of the contents of the database.

For the avoidance of doubt, this Section 4 supplements and does not replace Your obligations under this Public License where the Licensed Rights include other Copyright and Similar Rights.

Section 5 – Disclaimer of Warranties and Limitation of Liability.

a. Unless otherwise separately undertaken by the Licensor, to the extent possible, the Licensor offers the Licensed Material as-is and as-available, and makes no representations or warranties of any kind concerning the Licensed Material, whether express, implied, statutory, or other. This includes, without limitation, warranties of title, merchantability, fitness for a particular purpose, non-infringement, absence of latent or other defects, accuracy, or the presence or absence of errors,

whether or not known or discoverable. Where disclaimers of warranties are not allowed in full or in part, this disclaimer may not apply to You.

b. To the extent possible, in no event will the Licensor be liable to You on any legal theory (including, without limitation, negligence) or otherwise for any direct, special, indirect, incidental, consequential, punitive, exemplary, or other losses, costs, expenses, or damages arising out of this Public License or use of the Licensed Material, even if the Licensor has been advised of the possibility of such losses, costs, expenses, or damages. Where a limitation of liability is not allowed in full or in part, this limitation may not apply to You.

c. The disclaimer of warranties and limitation of liability provided above shall be interpreted in a manner that, to the extent possible, most closely approximates an absolute disclaimer and waiver of all liability.

Section 6 – Term and Termination.

a. This Public License applies for the term of the Copyright and Similar Rights licensed here. However, if You fail to comply with this Public License, then Your rights under this Public License terminate automatically.

b. Where Your right to use the Licensed Material has terminated under Section 6(a), it reinstates:

1. automatically as of the date the violation is cured, provided it is cured within 30 days of Your discovery of the violation; or

2. upon express reinstatement by the Licensor.

For the avoidance of doubt, this Section 6(b) does not affect any right the Licensor may have to seek remedies for Your violations of this Public License.

c. For the avoidance of doubt, the Licensor may also offer the Licensed Material under separate terms or conditions or stop distributing the Licensed Material at any time; however, doing so will not terminate this Public License.

d. Sections 1, 5, 6, 7, and 8 survive termination of this Public License.

Section 7 – Other Terms and Conditions.

a. The Licensor shall not be bound by any additional or different terms or conditions communicated by You unless expressly agreed.

b. Any arrangements, understandings, or agreements regarding the Licensed Material not stated herein are separate from and independent of the terms and conditions of this Public License.

Section 8 – Interpretation.

a. For the avoidance of doubt, this Public License does not, and shall not be interpreted to, reduce, limit, restrict, or impose conditions on any use of the Licensed Material that could lawfully

be made without permission under this Public License.

b. To the extent possible, if any provision of this Public License is deemed unenforceable, it shall be automatically reformed to the minimum extent necessary to make it enforceable. If the provision cannot be reformed, it shall be severed from this Public License without affecting the enforceability of the remaining terms and conditions.

c. No term or condition of this Public License will be waived and no failure to comply consented to unless expressly agreed to by the Licensor.

d. Nothing in this Public License constitutes or may be interpreted as a limitation upon, or waiver of, any privileges and immunities that apply to the Licensor or You, including from the legal processes of any jurisdiction or authority.

Creative Commons is not a party to its public licenses. Notwithstanding, Creative Commons may elect to apply one of its public licenses to material it publishes and in those instances will be considered the “Licensor.” Except for the limited purpose of indicating that material is shared under a Creative Commons public license or as otherwise permitted by the Creative Commons policies published at creativecommons.org/policies, Creative Commons does not authorize the use of the trademark “Creative Commons” or any other trademark or logo of Creative Commons without its prior written consent including, without limitation, in connection with any unauthorized modifications to any of its public licenses or any other arrangements, understandings, or agreements concerning use of licensed material. For the avoidance of doubt, this paragraph does not form part of the public licenses.

Creative Commons may be contacted at creativecommons.org.

Appendix E

References

Fleming, John Ambrose, *The Alternating Current Transformer In Theory And Practice*, Volume I (“The Induction of Electric Currents”), new edition, London, England, 1900.

Fleming, John Ambrose, *The Alternating Current Transformer In Theory And Practice*, Volume II (“The Utilization of Induced Currents”), London, England, 1892.

Greene, S. Dana, “Distribution of the Electrical Energy from Niagara Falls”, *Cassier’s Magazine*, Volume 8, pp. 333-362, London, England, 1895.

Hering, Carl, “The Transmission of Power”, *Cassier’s Magazine*, Volume 1, pp. 449-456, The Cassier Magazine Company, New York, April 1892.

IEEE C57.12.00-2010, IEEE Standard for General Requirements for Liquid-Immersed Distribution, Power, and Regulating Transformers, IEEE Power Engineering Society, New York, NY, 2010.

Appendix F

Version history

This is a list showing all significant additions, corrections, and other edits made to this learning module. Each entry is referenced by calendar date in reverse chronological order (newest version first), which appears on the front cover of every learning module for easy reference. Any contributors to this open-source document are listed here as well.

9 November 2024 – added a new “Challenging concept” to the Introduction chapter on autotransformers.

25 September 2024 – added a new Introduction section on challenging concepts.

18 July 2024 – added polarity dots to all the transformer windings shown in image_5408.

1 July 2024 – divided the Introduction chapter into two sections, one for students and one for instructors, and added content to the instructor section recommending learning outcomes and measures.

19 March 2024 – added Tutorial comments on the impossibility of transformer windings having fractional numbers of turns, and also added something similar to one of the Quantitative Reasoning questions.

29 February 2024 – added some more instructor notes.

27 February 2024 – added new questions to the Introduction chapter.

5 October 2023 – added new questions to the Introduction chapter, and also added some more explanatory text to the Full Tutorial on boosting versus bucking transformer configurations.

11 September 2023 – added a new Conceptual Reasoning question “Multi-wire secondary connections” based on the disassembly of an automotive battery booster unit that one of my students did as part of a high-current power supply project.

4 August 2023 – made capitalization of “Phi” (magnetic flux) consistent between equations, text,

and images.

27 July 2023 – minor edit in the Introduction chapter.

22 June 2023 – added a requirement in the “Explaining the meaning of calculations” Conceptual Question to also express each quantity using appropriate metric prefixes.

29 March 2023 – corrected an error in the “Calculating winding turns” Technical Reference section where I incorrectly referred to magnetic flux density (B) as magnetic field intensity. Also elaborated more on mitigation techniques for magnetic saturation in the same section.

28 February 2023 to 3 March 2023 – added $\times 100\%$ to the transformer impedance calculation formulae, and made minor edits to both Tutorials. Also added more questions to the Introduction chapter. Also added a new Technical Reference section on transformer parasitics.

8 January 2023 – added a new Case Tutorial section on building a sensitive audio detector.

28 November 2022 – placed questions at the top of the itemized list in the Introduction chapter prompting students to devise experiments related to the tutorial content.

13 August 2022 – added more circuits to the “Basic transformer calculations” Quantitative Reasoning question. Also added an “Explaining the meaning of calculations” Conceptual Question.

26-27 July 2022 – added “primary” and “secondary” labels to more transformer diagrams for clarity. Also clarified the concept of transformer impedance within the Simplified Tutorial. Also added a new Case Tutorial section showing four-winding control power transformer configurations.

23 July 2022 – Added Technical References sections on manufacturing different types of transformers.

19 May 2022 – renamed Tutorial section “Different transformer types” to “Transformer applications” and created a new section named “Transformer construction”.

31 March 2022 – added “Magnetic field quantities” to the Derivations and Technical References chapter.

9 December 2021 – expanded Case Tutorial section on transformer testing using a loudspeaker as a transient voltage source.

20 October 2021 – minor clarifications on the subject of transformer impedance and regulation percentage.

15 July 2021 – added new Case Tutorial chapter on testing transformer turns ratio and polarity using a loudspeaker and an oscilloscope.

23 June 2021 – minor edit on voltage regulation formula.

21 June 2021 – added new Case Tutorial chapter on boost/buck transformer connections.

9-10 June 2021 – added comments about magnetizing current to the Case Tutorial quantitative examples, and also added a new section title to the Full Tutorial.

8 May 2021 – commented out or deleted empty chapters.

18 April 2021 – changed all lower-case Greek letter “phi” symbols (ϕ) to upper-case (Φ).

6 March 2021 – added a Conceptual question on boost/buck transformer circuits.

2 March 2021 – minor edits, including capitalization correction on words like “Volt”, and adding formulae to the Simplified and Full Tutorials to calculate percentage impedance. Also made minor edits to image_0731, and added a new Case Tutorial section showing photographs of power transformers.

5 January 2021 – added a Diagnostic question on testing transformer polarity.

9 November 2020 – minor edits to the Simplified Tutorial.

14 October 2020 – significantly edited the Introduction chapter to make it more suitable as a pre-study guide and to provide cues useful to instructors leading “inverted” teaching sessions.

21 April 2020 – commented out “complex voltage and currents” Case Tutorial example for completion at a later date.

13 April 2020 – minor typographical error correction, courtesy of Ty Weich. Also, added a Case Tutorial chapter with examples, changed the title of a Full Tutorial section from “Power transformer impedance” to “Power transformer impedance ratings”, and added a new Full Tutorial section “Impedance transformation”.

17 December 2019 – added footnote defining common-mode voltage.

22 April 2019 – minor edits made to the Tutorial, also added a Quantitative Reasoning question.

28 March 2019 – added content to Tutorial chapters on autotransformers.

27 March 2019 – wrote the “Simplified Tutorial” chapter.

5 November 2018 – retitled Historical References section(s) so as to not be redundant to the “Historical References” chapter.

September 2018 – renamed “Derivations and Technical References” chapter to “Historical References”.

August 2018 – added comments on laminated iron cores, as well as added content to the Introduction. Added an historical reference on “divided” iron transformer cores, from early experiments.

July 2018 – document first created.

Index

- P*, 52
- Q*, 52
- S*, 52

- Adding quantities to a qualitative problem, 124
- Additive transformer windings, 50
- Additive windings, 50
- Annotating diagrams, 123
- Apparent power, 52, 58
- Arc, 54
- Arc blast, 55
- Autotransformer, 32, 45

- Bobbin, 62
- Bobbin, split, 64
- Bolted fault, 55

- Cassier's Magazine, 31, 43
- Cathode-ray tube, 71
- CGS, 79
- Checking for exceptions, 124
- Checking your work, 124
- Code, computer, 131
- Common-mode voltage, 34, 59
- Conservation of Energy, 24, 28, 32, 44, 56
- Conventional flow notation, 71
- Coulomb, 70
- Cross product, 71
- Cross-product, 70
- CRT, 71
- CT, 34, 60
- CT safety, 36, 61
- Current source, 35, 61
- Current source, CT as, 36, 61
- Current transformer, 34, 60
- Current transformer safety, 36, 61
- Current, excitation, 87
- Current, magnetization, 87

- Dimensional analysis, 72, 123

- E/I transformer core, 62
- Edwards, Tim, 132
- Electromotive force, 78
- Electron flow notation, 71
- emf, 78
- Excitation current, 87

- Faraday's Law of Electromagnetic Induction, 27, 28, 38, 81, 87
- Fault, 54
- Field intensity, magnetic, 78
- Flux density, magnetic, 74

- Gauss, 74
- Graph values to solve a problem, 124
- Greenleaf, Cynthia, 95

- How to teach with these modules, 126
- Hwang, Andrew D., 133

- I/E transformer core, 62
- Identify given data, 123
- Identify relevant principles, 123
- IEEE standard C57.12.00-2010, 50
- Impedance, 33
- Impedance, load, 56
- Impedance, percentage, 54
- Impedance, transformed, 57
- Impedance, transformer, 54
- Impulse, 52
- Inductance, leakage, 58
- Induction, mutual, 38
- Induction, self, 28, 38
- Inductive reactance, 53, 87

- Instructions for projects and experiments, 127
- Intermediate results, 123
- Inverted instruction, 126

- Kirchhoff's Voltage Law, 27, 38, 41, 51
- Knuth, Donald, 132

- Lampert, Leslie, 132
- Leakage inductance, 58
- Left-hand rule, 71
- Limiting cases, 124
- Linear Variable Differential Transformer, 34, 60
- Load, 28, 38, 40, 41
- Load impedance, 56
- Lorentz force, 70
- LVDT, 34, 60

- Magnetic circuit, 78
- Magnetic field intensity, 78
- Magnetic flux density, 74
- Magnetic saturation, 33, 48, 52
- Magnetization current, 87
- Magnetizing current, 10, 11
- Magnetomotive force, 78
- Maxwell, James Clerk, 65
- Metacognition, 100
- Metric system, CGS, 79
- Metric system, SI, 79
- mmf, 78
- Moolenaar, Bram, 131
- Murphy, Lynn, 95
- Mutual induction, 38

- Newton, 70, 72
- NOAA, 74
- Null detector, 23

- Open-source, 131

- Parasitic effect, 84
- Particle accelerator, 71
- Permeability, 74
- Potential transformer, 34, 60
- Power, apparent, 58
- Power, reactive, 58
- Power, true, 58
- Primary winding, 29, 39

- Problem-solving: annotate diagrams, 123
- Problem-solving: check for exceptions, 124
- Problem-solving: checking work, 124
- Problem-solving: dimensional analysis, 123
- Problem-solving: graph values, 124
- Problem-solving: identify given data, 123
- Problem-solving: identify relevant principles, 123
- Problem-solving: interpret intermediate results, 123
- Problem-solving: limiting cases, 124
- Problem-solving: qualitative to quantitative, 124
- Problem-solving: quantitative to qualitative, 124
- Problem-solving: reductio ad absurdum, 124
- Problem-solving: simplify the system, 123
- Problem-solving: thought experiment, 76, 77, 123
- Problem-solving: track units of measurement, 123
- Problem-solving: visually represent the system, 123
- Problem-solving: work in reverse, 124
- PT, 34, 60

- Qualitatively approaching a quantitative problem, 124

- Reactance, 58
- Reactance, inductive, 53, 87
- Reactive power, 52, 58
- Reading Apprenticeship, 95
- Reductio ad absurdum, 124–126
- Right-hand rule, 71
- Rotary converter, 43
- Rotary Variable Differential Transformer, 34, 60
- RVDT, 34, 60

- Safety, current transformer, 36, 61
- Sag, voltage, 55
- Saturation, 33, 48, 52
- Schoenbach, Ruth, 95
- Scientific method, 100
- Secondary winding, 29, 39
- Self induction, 38
- Self-induction, 28, 38
- Shorting switch, 36, 61
- SI, 79

- Simplifying a system, 123
- Socrates, 125
- Socratic dialogue, 126
- Solenoid, 76
- Source, 28, 38
- SPICE, 95
- Split bobbin, 64
- Stallman, Richard, 131
- Subtractive transformer windings, 50
- Subtractive windings, 50
- Superconductor, 75

- Tap, 32, 45
- Tension, 67
- Tesla, 70, 72, 74, 76, 77
- Thought experiment, 76, 77, 123
- Toroid, 77
- Toroidal transformer core, 64
- Torvalds, Linus, 131
- Transformed impedance, 57
- Transformer, 39
- Transformer impedance, 54
- Transformer voltage regulation, 55
- Transformer, additive windings, 50
- Transformer, subtractive windings, 50
- Transient, 52
- Transient signal, 12
- Transitive property, 42
- True power, 52, 58

- Units of measurement, 123
- Unity fraction, 83

- VA, 52
- Vector, 70
- Vector cross-product, 71
- Visualizing a system, 123
- Volt-Ampere, 33, 52
- Voltage, 78
- Voltage regulation, transformer, 55
- Voltage sag, 55
- Voltage source, 35, 61
- Voltage, common-mode, 34, 59

- Weber, 74
- Winding, 29, 39

- Wiper, 45
- WMM, 74
- Work in reverse to solve a problem, 124
- World Magnetic Model, 74
- WYSIWYG, 131, 132