

Lab

Reversing three-phase motor starter circuit and PLC trainer construction: *Question 71, completed objectives due by the end of day 4*

PLC trainer details: *Question 72*

---

Exam

*Day 4* – only a simple calculator may be used! **Complete mastery of these objectives due by the next exam date**

*Specific objectives for the “mastery” exam:*

- Electricity Review: Calculate voltages and currents in a DC series-parallel resistor circuit given source and resistor values
  - Sketch proper wire connections for a relay control circuit
  - Determine status of a relay logic circuit given a schematic diagram and switch stimulus conditions
  - Calculate either the full-load current or the horsepower of an electric motor (single-phase) given the line voltage and one of the other parameters
  - Solve for a specified variable in an algebraic formula
  - Determine the possibility of suggested faults in a simple circuit given measured values (voltage, current), a schematic diagram, and reported symptoms
  - INST241 Review: Identify (American) wire colors for different thermocouple types
  - INST251 Review: Determine the effect of a component fault or condition change in a single-loop controlled process
  - INST260 Review: Convert between different numeration systems (decimal, binary, hexadecimal, octal)
- 

**Recommended daily schedule**

---

Day 1

**Theory session topic:** Process switches and control circuits

Questions 1 through 20; answer questions 1-9 in preparation for discussion (remainder for practice)

---

Day 2

**Theory session topic:** Soft start and variable-frequency drives

Questions 21 through 40; answer questions 21-28 in preparation for discussion (remainder for practice)

---

Day 3

**Theory session topic:** Review for exam

Questions 41 through 60; answer questions 41-50 in preparation for discussion (remainder for practice)

Feedback questions (*61 through 70*) are optional and may be submitted for review at the end of the day

---

Day 4

**Exam**

## How To . . .

**Access the worksheets and textbook:** go to the *Socratic Instrumentation* website located at <http://www.ibiblio.org/kuphaldt/socratic/sinst> to find worksheets for every 2nd-year course section organized by quarter, as well as both the latest “stable” and “development” versions of the *Lessons In Industrial Instrumentation* textbook. Download and save these documents to your computer.

**Maximize your learning:** complete all homework *before* class starts, ready to be assessed as described in the “Inverted Session Formats” pages. Use every minute of class and lab time productively. Follow all the tips outlined in “Question 0” as well as your instructor’s advice. Do not take constructive criticism personally. Make every reasonable effort to solve problems on your own before seeking help.

**Identify upcoming assignments and deadlines:** read the first page of each course worksheet.

**Relate course days to calendar dates:** reference the calendar spreadsheet file (`calendar.xlsx`), found on the BTC campus Y: network drive. A printed copy is posted in the Instrumentation classroom.

**Locate industry documents assigned for reading:** use the Instrumentation Reference provided by your instructor (on CD-ROM and on the BTC campus Y: network drive). There you will find a file named `00_index_OPEN_THIS_FILE.html` readable with any internet browser. Click on the “Quick-Start Links” to access assigned reading documents, organized per course, in the order they are assigned.

**Study for the exams:** Mastery exams assess specific skills critically important to your success, listed near the top of the front page of each course worksheet for your review. Familiarize yourself with this list and pay close attention when those topics appear in homework and practice problems. Proportional exams feature problems you haven’t seen before that are solvable using general principles learned throughout the current and previous courses, for which the only adequate preparation is independent problem-solving practice every day. Answer the “feedback questions” (practice exams) in each course section to hone your problem-solving skills, as these are similar in scope and complexity to proportional exams. Answer these feedback independently (i.e. no help from classmates) in order to most accurately assess your readiness.

**Calculate course grades:** download the “Course Grading Spreadsheet” (`grades_template.xlsx`) from the Socratic Instrumentation website, or from the BTC campus Y: network drive. Enter your quiz scores, test scores, lab scores, and attendance data into this Excel spreadsheet and it will calculate your course grade. You may compare your calculated grades against your instructors’ records at any time.

**Identify courses to register for:** read the “Sequence” page found in each worksheet.

**Receive extra instructor help:** ask during lab time, or during class time, or by appointment.

**Identify job openings:** regularly monitor job-search websites. Set up informational interviews at workplaces you are interested in. Participate in jobshadows and internships. Apply to jobs long before graduation, as some employers take *months* to respond! Check your BTC email account daily, because your instructor broadcast-emails job postings to all students as employers submit them to BTC.

**Impress employers:** sign the FERPA release form granting your instructors permission to share academic records, then make sure your performance is worth sharing. Document your project and problem-solving experiences for reference during interviews. Honor all your commitments.

**Begin your career:** participate in jobshadows and internships while in school to gain experience and references. Take the first Instrumentation job that pays the bills, and give that employer at least two years of good work to pay them back for the investment they have made in you. Employers look at delayed employment, as well as short employment spans, very negatively. Failure to pass a drug test is an immediate disqualifier, as is falsifying any information. Criminal records may also be a problem.

[file howto](#)

## General Values, Expectations, and Standards

Success in this career requires professional integrity, resourcefulness, persistence, close attention to detail, and intellectual curiosity. If you are ever in doubt as to the values you should embody, just ask yourself what kind of a person you would prefer to hire for your own enterprise. Those same values will be upheld within this program.

**Learning** is the top priority in this program. Every circumstance, every incident, every day will be treated as a learning opportunity, every mistake as a “teachable moment”. Every form of positive growth, not just academic ability, will be regarded as real learning.

**Responsibility** means *ensuring* the desired outcome, not just *trying* to achieve the outcome. If your efforts do not yield the expected results, only you can make it right.

**Integrity** means being honest and forthright in all your words and actions, doing your very best every time and never taking credit for the achievement of another.

**Safety** means doing every job correctly and ensuring others are not endangered. Lab safety standards include wearing closed-toed shoes and safety glasses in the lab room during lab hours, wearing ear protection around loud sounds, using ladders to reach high places, using proper lock-out/tag-out procedures, no energized electrical work above 30 volts without an instructor present in the lab room, and no power tool use without an instructor present in the lab room.

**Diligence** means exercising self-discipline and persistence in your studies, realizing that hard work is a necessary condition for success. This means, among other things, investing the necessary time and effort in studying, reading instructions, paying attention to details, utilizing the skills and tools you already possess, and avoiding shortcuts.

**Mastery** means the job is not done until it is done *correctly*: all objectives achieved, all problems solved, all documentation complete, and no errors remaining.

**Self-management** means allocating your resources (time, equipment, labor) wisely, and not just focusing on the nearest deadline.

**Communication** means clearly conveying your thoughts and paying attention to what others convey. Remember that no one can read your mind, and so it is incumbent upon you to communicate any and all important information.

**Teamwork** means working constructively with your classmates so as to maximize their learning as well as your own.

**Initiative** means recognizing needs and taking action to meet those needs without encouragement or direction from others.

**Representation** means your actions are a reflection of this program and not just of yourself. Doors of opportunity for all BTC graduates may be opened or closed by your own conduct. Unprofessional behavior during tours, jobshadows, internships, and/or jobs reflects poorly on the program and will negatively bias employers.

**Trustworthiness** is the result of consistently exercising these values: people will recognize you as someone they can rely on to get the job done, and therefore someone they would want to hire.

**Respect** means acknowledging the intrinsic value, capabilities, and responsibilities of those around you. Respect may be gained by consistent demonstration of valued behaviors, and it may be lost through betrayal of trust.

## General Values, Expectations, and Standards (continued)

**Punctuality and Attendance:** late arrivals are penalized at a rate of 1% grade deduction per incident. Absence is penalized at a rate of 1% per hour (rounded to the nearest hour) except when employment-related, school-related, weather-related, or required by law (e.g. court summons). Absences may be made up by directing the instructor to apply “sick hours” (12 hours of sick time available per quarter). Classmates may donate their unused sick hours. Sick hours may not be applied to unannounced absences, so be sure to alert your instructor and teammates as soon as you know you will be absent or late. Absence on an exam day will result in a zero score for that exam, unless due to a documented emergency.

**Mastery:** any assignment or objective labeled as “mastery” must be completed with 100% competence (with multiple opportunities to re-try). Failure to complete by the deadline date caps your grade at a C-. Failure to complete by the end of the *next* school day results in a failing (F) grade for that course.

**Time Management:** Use all available time wisely and productively. Work on other useful tasks (e.g. homework, feedback questions, job searching) while waiting for other activities or assessments to begin. Trips to the cafeteria for food or coffee, smoke breaks, etc. must not interfere with team participation.

**Orderliness:** Keep your work area clean and orderly, discarding trash, returning tools at the end of every lab session, and participating in all scheduled lab clean-up sessions. Project wiring, especially in shared areas such as junction boxes, must not be left in disarray at the end of a lab shift. Label any failed equipment with a detailed description of its symptoms.

**Independent Study:** the “inverted” instructional model used in this program requires independent reading and problem-solving, where every student must demonstrate their learning at the start of the class session. Question 0 of every worksheet lists practical study tips. The “Inverted Session Formats” pages found in every worksheet outline the format and grading standards for inverted class sessions.

**Independent Problem-Solving:** make an honest effort to solve every problem before seeking help. When working in the lab, help will not be given to you unless and until you run your own diagnostic tests.

**Teamwork:** inform your teammates if you need to leave the work area for any reason. Any student regularly compromising team performance through absence, tardiness, disrespect, or other disruptive behavior(s) will be removed from the team and required to complete all labwork individually. The same is true for students found inappropriately relying on teammates.

**Communication:** check your email account daily for important messages from your instructor. Ask the instructor to clarify any assignment or exam question you find confusing, and express your work clearly and compellingly.

**Academic Progress:** your instructor will record your academic achievement, as well as comments on any negative behavior, and will share all these records with employers provided you have signed the FERPA release form. You are welcome to see these records at any time, and are encouraged to track your own academic progress using the grade spreadsheet template.

**Office Hours:** your instructor’s office hours are by appointment, except in cases of emergency. Email is the preferred method for setting up an appointment with your instructor to discuss something in private.

**Grounds for Failure:** a failing (F) grade will be earned in any course if any mastery objectives are past deadline by more than one school day, or if any of the following behaviors are demonstrated: false testimony (lying) to your instructor, cheating on any assignment or assessment, plagiarism (presenting another’s work as your own), willful violation of a safety policy, theft, harassment, intoxication, or destruction of property. Such behaviors are grounds for immediate termination in this career, and as such will not be tolerated here.

file expectations

## Inverted session formats

The basic concept of an “inverted” learning environment is that the traditional allocations of student time are reversed: instead of students attending an instructor-led session to receive new information and then practicing the application of that information outside of the classroom in the form of homework, students in an inverted class encounter new information outside of the classroom via homework and apply that information in the classroom session under the instructor’s tutelage.

A natural question for instructors, then, is what their precise role is in an inverted classroom and how to organize that time well. Here I will list alternate formats suitable for an inverted classroom session, each of them tested and proven to work.

### Small sessions

Students meet with instructors in small groups for short time periods. Groups of 4 students meeting for 30 minutes works very well, but groups as large as 8 students apiece may be used if time is limited. Each of these sessions begins with a 5 to 10 minute graded inspection of homework with individual questioning, to keep students accountable for doing the homework. The remainder of the session is a dialogue focusing on the topics of the day, the instructor challenging each student on the subject matter in Socratic fashion, and also answering students’ questions. A second grade measures each student’s comprehension of the subject matter by the end of the session.

This format also works via teleconferencing, for students unable to attend a face-to-face session on campus.

### Large sessions

Students meet with instructors in a standard classroom (normal class size and period length). Each of these sessions begins with a 10 minute graded quiz (closed-book) on the homework topic(s), to keep students accountable for doing the homework. Students may leave the session as soon as they “check off” with the instructor in a Socratic dialogue as described above (instructor challenging each student to assess their comprehension, answering questions, and grading the responses). Students sign up for check-off on the whiteboard when they are ready, typically in groups of no more than 4. Alternatively, the bulk of the class session may be spent answering student questions in small groups, followed by another graded quiz at the end.

### Correspondence

This format works for students unable to attend a “face-to-face” session, and who must correspond with the instructor via email or other asynchronous medium. Each student submits a thorough presentation of their completed homework, which the instructor grades for completeness and accuracy. The instructor then replies back to the student with challenge questions, and also answers questions the student may have. As with the previous formats, the student receives another grade assessing their comprehension of the subject matter by the close of the correspondence dialogue.

In all formats, students are held accountable for completion of their homework, “completion” being defined as successfully interpreting the given information from source material (e.g. accurate outlines of reading or video assignments) and constructive effort to solve given problems. It must be understood in an inverted learning environment that students *will* have legitimate questions following a homework assignment, and that it is therefore unreasonable to expect mastery of the assigned subject matter. What is reasonable to expect from each and every student is a basic outline of the source material (reading or video assignments) complete with major terms defined and major concepts identified, plus a good-faith effort to solve every problem. Question 0 (contained in every worksheet) lists multiple strategies for effective study and problem-solving.

**Sample rubric for pre-assessments**

- **No credit** = Any homework question unattempted (i.e. no effort shown on one or more questions); incomprehensible writing; failure to follow clear instruction(s)
- **Half credit** = Misconception(s) on any major topic explained in the assigned reading; answers shown with no supporting work; verbatim copying of text rather than written in your own words; outline missing important topic(s); unable to explain the outline or solution methods represented in written work
- **Full credit** = Every homework question answered, with any points of confusion clearly articulated; all important concepts from reading assignments accurately expressed in the outline and clearly articulated when called upon by the instructor to explain

*The minimum expectation at the start of every student-instructor session is that all students have made a good-faith effort to complete 100% of their assigned homework. This does not necessarily mean all answers will be correct, or that all concepts are fully understood, because one of the purposes of the meeting between students and instructor is to correct remaining misconceptions and answer students' questions. However, experience has shown that without accountability for the homework, a substantial number of students will not put forth their best effort and that this compromises the whole learning process. Full credit is reserved for good-faith effort, where each student thoughtfully applies the study and problem-solving recommendations given to them (see Question 0).*

**Sample rubric for post-assessments**

- **No credit** = Failure to comprehend one or more key concepts; failure to apply logical reasoning to the solution of problem(s); no contribution to the dialogue
- **Half credit** = Some misconceptions persist by the close of the session; problem-solving is inconsistent; limited contribution to the dialogue
- **Full credit** = Socratic queries answered thoughtfully; effective reasoning applied to problems; ideas communicated clearly and accurately; responds intelligently to questions and statements made by others in the session; adds new ideas and perspectives

*The minimum expectation is that each and every student engages with the instructor and with fellow students during the Socratic session: posing intelligent questions of their own, explaining their reasoning when challenged, and otherwise positively contributing to the discussion. Passive observation and listening is not an option here – every student must be an active participant, contributing something original to every dialogue. If a student is confused about any concept or solution, it is their responsibility to ask questions and seek resolution.*

If a student happens to be absent for a scheduled class session and is therefore unable to be assessed on that day's study, they may schedule a time with the instructor to demonstrate their comprehension at some later date (before the end of the quarter when grades must be submitted). These same standards of performance apply equally make-up assessments: either inspection of homework or a closed-book quiz for the pre-assessment, and either a Socratic dialogue with the instructor or another closed-book quiz for the post-assessment.

file format

## Course Syllabus

### INSTRUCTOR CONTACT INFORMATION:

Tony Kuphaldt  
(360)-752-8477 [office phone]  
(360)-752-7277 [fax]  
tony.kuphaldt@btc.edu

**DEPT/COURSE #:** INST 230

**CREDITS:** 3      **Lecture Hours:** 11      **Lab Hours:** 44      **Work-based Hours:** 0

**COURSE TITLE:** Motor Controls

**COURSE DESCRIPTION:** In this course you will learn how to wire, configure, and use electromechanical contactors to control electric motors and other discrete (on/off) control elements for real processes. You will also learn how to wire, configure, and use variable-frequency motor controls to use three-phase AC motors as final control elements. **Prerequisite courses:** ELTR145 (Digital 2) and MATH&141 (Precalculus 1) with a minimum grade of "C"

**COURSE OUTCOMES:** Commission, analyze, and efficiently diagnose motor control systems incorporating electromechanical relays and variable-frequency drive (VFD) units.

**COURSE OUTCOME ASSESSMENT:** Motor control system commissioning, analysis, and diagnosis outcomes are ensured by measuring student performance against mastery standards, as documented in the Student Performance Objectives. Failure to meet all mastery standards by the next scheduled exam day will result in a failing grade for the course.

## STUDENT PERFORMANCE OBJECTIVES:

- Without references or notes, within a limited time (3 hours total for each exam session), independently perform the following tasks. Multiple re-tries are allowed on mastery (100% accuracy) objectives, each with a different set of problems:
  - Calculate voltages and currents in a DC series-parallel resistor circuit given source and resistor values, with 100% accuracy (mastery)
  - Sketch proper wire connections for a relay control circuit given a pictorial or schematic diagram of the components, with 100% accuracy (mastery)
  - Determine status of a relay logic circuit given a schematic diagram and switch stimulus conditions, with 100% accuracy (mastery)
  - Calculate current and horsepower ratings of a single-phase electrical motor for a given line voltage with 100% accuracy (mastery)
  - Solve for specified variables in algebraic formulae, with 100% accuracy (mastery)
  - Determine the possibility of suggested faults in a simple circuit given measured values (voltage, current), a schematic diagram, and reported symptoms, with 100% accuracy (mastery)
  - Predict the response of electric motor control systems to component faults and changes in process conditions, given pictorial and/or schematic illustrations
  - Sketch proper power and signal connections between individual motor control components to fulfill a specified control system function, given pictorial and/or schematic illustrations of those instruments
- In a team environment and with full access to references, notes, and instructor assistance, perform the following tasks:
  - Demonstrate proper use of safety equipment and application of safe procedures while using power tools, and working on live systems
  - Communicate effectively with teammates to plan work, arrange for absences, and share responsibilities in completing all labwork
  - Construct and commission a three-phase reversing motor starter system
  - Connect three power transformers together to form a three-phase transformer bank with specified configuration (e.g. Delta-Delta, Delta-Wye)
  - Generate an accurate wiring diagram compliant with industry standards documenting your team's motor control system
  - Construct and test a PLC "trainer" board utilizing a small PLC connected to input switches and indicator lamps
- Independently perform the following tasks on a functioning motor starter system with 100% accuracy (mastery). Multiple re-tries are allowed with different specifications/conditions each time:
  - Properly wire a start/stop motor control circuit, given components randomly selected by the instructor
  - Test for ground faults in a motor starter system using an insulation tester ("megger")
  - Demonstrate how to secure power to a motor starter using proper lock-out and testing procedures
  - Diagnose a random fault placed in another team's motor control system by the instructor within a limited time using no test equipment except a multimeter, logically justifying your steps in the instructor's direct presence

**COURSE OUTLINE:** A course calendar in electronic format (Excel spreadsheet) resides on the Y: network drive, and also in printed paper format in classroom DMC130, for convenient student access. This calendar is updated to reflect schedule changes resulting from employer recruiting visits, interviews, and other impromptu events. Course worksheets provide comprehensive lists of all course assignments and activities, with the first page outlining the schedule and sequencing of topics and assignment due dates. These worksheets are available in PDF format at <http://www.ibiblio.org/kuphaldt/socratic/sinst>

- INST230 Section 1 (Motors and relay controls): 4 days theory and labwork
- INST230 Section 2 (Solid-state motor controls): 3 days theory and labwork + 1 day for mastery/proportional exams



**METHODS OF INSTRUCTION:** Course structure and methods are intentionally designed to develop critical-thinking and life-long learning abilities, continually placing the student in an active rather than a passive role.

- **Independent study:** daily worksheet questions specify *reading assignments*, *problems* to solve, and *experiments* to perform in preparation (before) classroom theory sessions. Open-note quizzes and work inspections ensure accountability for this essential preparatory work. The purpose of this is to convey information and basic concepts, so valuable class time isn't wasted transmitting bare facts, and also to foster the independent research ability necessary for self-directed learning in your career.
- **Classroom sessions:** a combination of *Socratic discussion*, short *lectures*, *small-group* problem-solving, and hands-on *demonstrations/experiments* review and illuminate concepts covered in the preparatory questions. The purpose of this is to develop problem-solving skills, strengthen conceptual understanding, and practice both quantitative and qualitative analysis techniques.
- **Lab activities:** an emphasis on constructing and documenting *working projects* (real instrumentation and control systems) to illuminate theoretical knowledge with practical contexts. Special projects off-campus or in different areas of campus (e.g. BTC's Fish Hatchery) are encouraged. Hands-on *troubleshooting exercises* build diagnostic skills.
- **Feedback questions:** sets of *practice problems* at the end of each course section challenge your knowledge and problem-solving ability in current as well as first year (Electronics) subjects. These are optional assignments, counting neither for nor against your grade. Their purpose is to provide you and your instructor with direct feedback on what you have learned.

**STUDENT ASSIGNMENTS/REQUIREMENTS:** All assignments for this course are thoroughly documented in the following course worksheets located at:

<http://www.ibiblio.org/kuphaldt/socratic/sinst/index.html>

- INST230\_sec1.pdf
- INST230\_sec2.pdf

**EVALUATION AND GRADING STANDARDS:** (out of 100% for the course grade)

- Completion of all mastery objectives = 50%
- Mastery exam score = 10%
- Proportional exam score = 30%
- Lab questions = 10%
- Quiz penalty = -1% per failed quiz
- Tardiness penalty = -1% per incident (1 “free” tardy per course)
- Attendance penalty = -1% per hour (12 hours “sick time” per quarter)
- Extra credit = +5% per project (assigned by instructor based on individual learning needs)

All grades are criterion-referenced (i.e. no grading on a “curve”)

100% ≥ <b>A</b> ≥ 95%	95% > <b>A-</b> ≥ 90%		
90% > <b>B+</b> ≥ 86%	86% > <b>B</b> ≥ 83%	83% > <b>B-</b> ≥ 80%	
80% > <b>C+</b> ≥ 76%	76% > <b>C</b> ≥ 73%	73% > <b>C-</b> ≥ 70%	(minimum passing course grade)
70% > <b>D+</b> ≥ 66%	66% > <b>D</b> ≥ 63%	63% > <b>D-</b> ≥ 60%	60% > <b>F</b>

Absence on a scheduled exam day will result in a 0% score for the proportional exam unless you provide documented evidence of an unavoidable emergency.

If you fail a mastery exam, you must re-take a different version of that mastery exam on a different day. Multiple re-tries are allowed, on a different version of the exam each re-try. There is no penalty levied on your course grade for re-taking mastery exams, but failure to successfully pass a mastery exam by the due date will result in a failing grade (F) for the course.

If any other “mastery” objectives are not completed by their specified deadlines, your overall grade for the course will be capped at 70% (C- grade), and you will have one more school day to complete the unfinished objectives. Failure to complete those mastery objectives by the end of that extra day (except in the case of documented, unavoidable emergencies) will result in a failing grade (F) for the course.

“Lab questions” are assessed in a written exam format, typically on the last scheduled day of the lab project. Grading is as follows: full credit for thorough, correct answers; half credit for partially correct answers; and zero credit for major conceptual errors.

Individual preparation for Socratic dialogue sessions is measured by a “prep quiz” and/or personal inspection of your work by the instructor. A second (“summary”) quiz score for every Socratic session marks your participatory dialogue and ability to give reasoned answers to challenge questions on that session’s topic(s). In the event of absence, these scores may be credited by having your preparatory work and demonstration of understanding reviewed at any time before the end of the quarter in a one-on-one dialogue with the instructor.

Extra credit opportunities exist for each course, and may be assigned to students upon request. The student and the instructor will first review the student’s performance on feedback questions, homework, exams, and any other relevant indicators in order to identify areas of conceptual or practical weakness. Then, both will work together to select an appropriate extra credit activity focusing on those identified weaknesses, for the purpose of strengthening the student’s competence. A due date will be assigned (typically two weeks following the request), which must be honored in order for any credit to be earned from the activity. Extra credit may be denied at the instructor’s discretion if the student has not invested the necessary preparatory effort to perform well (e.g. lack of preparation for daily class sessions, poor attendance, no feedback questions submitted, etc.).

## REQUIRED STUDENT SUPPLIES AND MATERIALS:

- Course worksheets available for download in PDF format
- *Lessons in Industrial Instrumentation* textbook, available for download in PDF format  
→ Access worksheets and book at: <http://www.ibiblio.org/kuphaldt/socratic/sinst>
- Ampacity ratings of wire from the *National Electrical Code* (NFPA 70) reference, available for free online viewing at <http://www.nfpa.org>
- NFPA 70E “Standard for Electrical Safety in the Workplace”
- Spiral-bound notebook for reading annotation, homework documentation, and note-taking.
- Instrumentation reference CD-ROM (free, from instructor). This disk contains many tutorials and datasheets in PDF format to supplement your textbook(s).
- Tool kit (see detailed list)
- Simple scientific calculator (non-programmable, non-graphing, no unit conversions, no numeration system conversions), TI-30Xa or TI-30XIIS recommended
- Portable personal computer with Ethernet port and wireless. Windows OS strongly preferred, tablets discouraged.

# Sequence of second-year Instrumentation courses

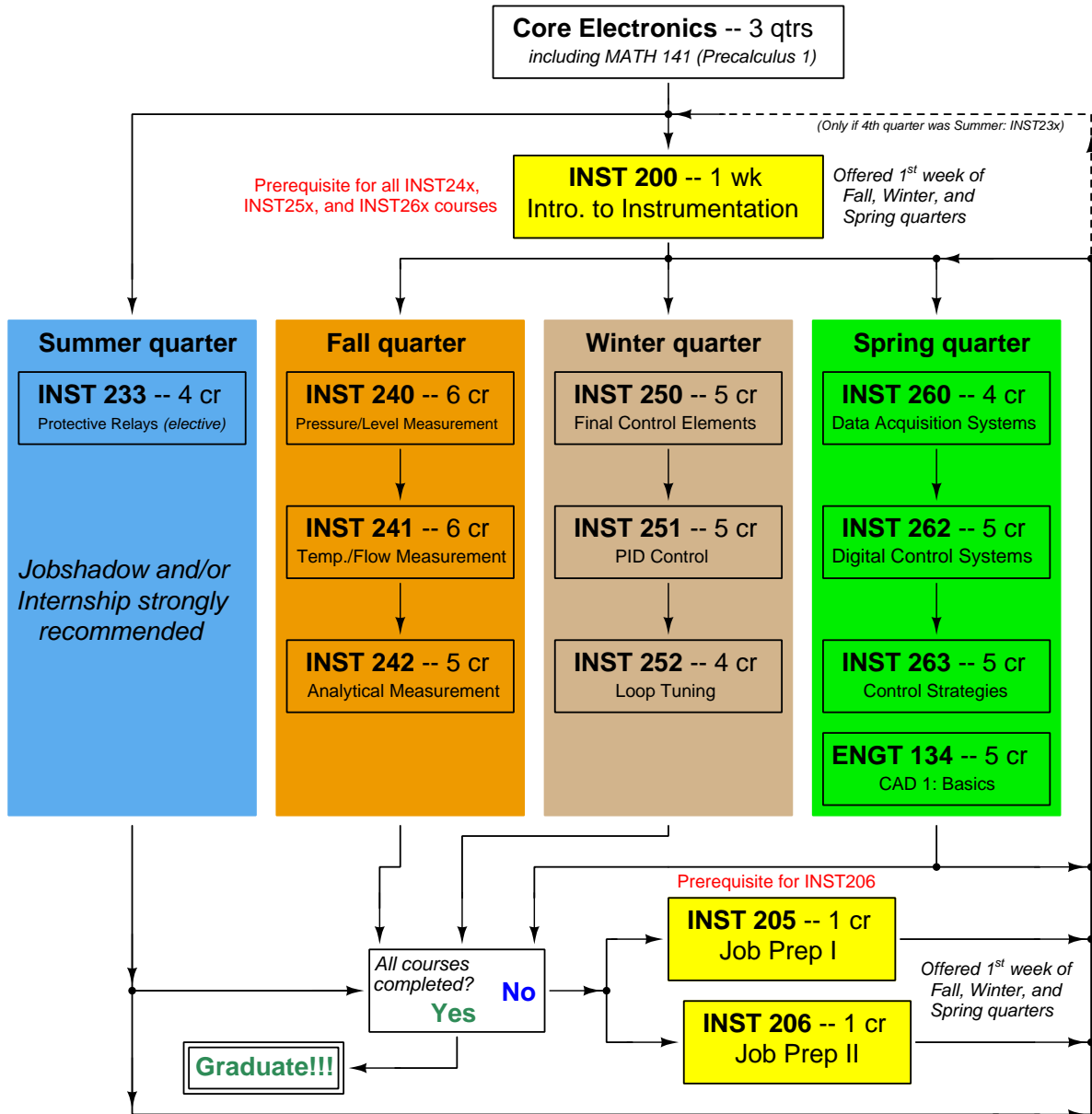

The particular sequence of courses you take during the second year depends on when you complete all first-year courses and enter the second year. Since students enter the second year of Instrumentation at four different times (beginnings of Summer, Fall, Winter, and Spring quarters), the particular course sequence for any student will likely be different from the course sequence of classmates.

Some second-year courses are only offered in particular quarters with those quarters not having to be in sequence, while others are offered three out of the four quarters and must be taken in sequence. The following layout shows four typical course sequences for second-year Instrumentation students, depending on when they first enter the second year of the program:

### Possible course schedules depending on date of entry into 2nd year



file sequence

## General tool and supply list

### Wrenches

- Combination (box- and open-end) wrench set, 1/4" to 3/4" – *the most important wrench sizes are 7/16", 1/2", 9/16", and 5/8"; get these immediately!*
- Adjustable wrench, 6" handle (sometimes called "Crescent" wrench)
- Hex wrench ("Allen" wrench) set, fractional – 1/16" to 3/8"
- *Optional:* Hex wrench ("Allen" wrench) set, metric – 1.5 mm to 10 mm
- *Optional:* Miniature combination wrench set, 3/32" to 1/4" (sometimes called an "ignition wrench" set)

Note: *when turning any threaded fastener, one should choose a tool engaging the maximum amount of surface area on the fastener's head in order to reduce stress on that fastener. (e.g. Using box-end wrenches instead of adjustable wrenches; using the proper size and type of screwdriver; never using any tool that mars the fastener such as pliers or vise-grips unless absolutely necessary.)*

### Pliers

- Needle-nose pliers
- Tongue-and-groove pliers (sometimes called "Channel-lock" pliers)
- Diagonal wire cutters (sometimes called "dikes")

### Screwdrivers

- Slotted, 1/8" and 1/4" shaft
- Phillips, #1 and #2
- Jeweler's screwdriver set
- *Optional:* Magnetic multi-bit screwdriver (e.g. Klein Tools model 70035)

### Electrical

- Multimeter, Fluke model 87-IV or better
- Alligator-clip jumper wires
- Soldering iron (10 to 40 watt) and rosin-core solder
- Resistor, potentiometer, diode assortments (from first-year lab kits)
- Package of insulated compression-style fork terminals (14 to 18 AWG wire size, #10 stud size)
- Wire strippers/terminal crimpers for 10 AWG to 18 AWG wire and insulated terminals
- *Optional:* ratcheting terminal crimp tool (e.g. Paladin 1305, Ferrules Direct FDT10011, or equivalent)

### Safety

- Safety glasses or goggles (available at BTC bookstore)
- Earplugs (available at BTC bookstore)

### Miscellaneous

- Simple scientific calculator (non-programmable, non-graphing, no conversions), TI-30Xa or TI-30XIIS recommended. Required for some exams!
- Portable personal computer with Ethernet port and wireless. Windows OS strongly preferred, tablets discouraged.
- Masking tape (for making temporary labels)
- Permanent marker pen
- Teflon pipe tape
- Utility knife
- Tape measure, 12 feet minimum
- Flashlight

An inexpensive source of tools is your local pawn shop. Look for tools with unlimited lifetime guarantees (e.g. *Sears* "Craftsman" brand). Check for BTC student discounts as well!

file tools

## Methods of instruction

This course develops self-instructional and diagnostic skills by placing students in situations where they are required to research and think independently. In all portions of the curriculum, the goal is to avoid a passive learning environment, favoring instead *active engagement* of the learner through reading, reflection, problem-solving, and experimental activities. The curriculum may be roughly divided into two portions: *theory* and *practical*.

### Theory

In the theory portion of each course, students independently research subjects *prior* to entering the classroom for discussion. This means working through all the day's assigned questions as completely as possible. This usually requires a fair amount of technical reading, and may also require setting up and running simple experiments. At the start of the classroom session, the instructor will check each student's preparation with a quiz. Students then spend the rest of the classroom time working in groups and directly with the instructor to *thoroughly* answer all questions assigned for that day, articulate problem-solving strategies, and to approach the questions from multiple perspectives. To put it simply: fact-gathering happens outside of class and is the individual responsibility of each student, so that class time may be devoted to the more complex tasks of critical thinking and problem solving where the instructor's attention is best applied.

Classroom theory sessions usually begin with either a brief Q&A discussion or with a "Virtual Troubleshooting" session where the instructor shows one of the day's diagnostic question diagrams while students propose diagnostic tests and the instructor tells those students what the test results would be given some imagined ("virtual") fault scenario, writing the test results on the board where all can see. The students then attempt to identify the nature and location of the fault, based on the test results.

Each student is free to leave the classroom when they have completely worked through all problems and have answered a "summary" quiz designed to gauge their learning during the theory session. If a student finishes ahead of time, they are free to leave, or may help tutor classmates who need extra help.

*The express goal of this "inverted classroom" teaching methodology is to help each student cultivate critical-thinking and problem-solving skills, and to sharpen their abilities as independent learners. While this approach may be very new to you, it is more realistic and beneficial to the type of work done in instrumentation, where critical thinking, problem-solving, and independent learning are "must-have" skills.*

## Lab

In the lab portion of each course, students work in teams to install, configure, document, calibrate, and troubleshoot working instrument loop systems. Each lab exercise focuses on a different type of instrument, with a eight-day period typically allotted for completion. An ordinary lab session might look like this:

- (1) Start of practical (lab) session: announcements and planning
  - (a) The instructor makes general announcements to all students
  - (b) The instructor works with team to plan that day's goals, making sure each team member has a clear idea of what they should accomplish
- (2) Teams work on lab unit completion according to recommended schedule:
  - (First day) Select and bench-test instrument(s)
  - (One day) Connect instrument(s) into a complete loop
  - (One day) Each team member drafts their own loop documentation, inspection done as a team (with instructor)
  - (One or two days) Each team member calibrates/configures the instrument(s)
  - (Remaining days, up to last) Each team member troubleshoots the instrument loop
- (3) End of practical (lab) session: debriefing where each team reports on their work to the whole class

### Troubleshooting assessments must meet the following guidelines:

- Troubleshooting must be performed *on a system the student did not build themselves*. This forces students to rely on another team's documentation rather than their own memory of how the system was built.
- Each student must individually demonstrate proper troubleshooting technique.
- Simply finding the fault is not good enough. Each student must consistently demonstrate sound reasoning while troubleshooting.
- If a student fails to properly diagnose the system fault, they must attempt (as many times as necessary) with different scenarios until they do, reviewing any mistakes with the instructor after each failed attempt.



## Distance delivery methods

Sometimes the demands of life prevent students from attending college 6 hours per day. In such cases, there exist alternatives to the normal 8:00 AM to 3:00 PM class/lab schedule, allowing students to complete coursework in non-traditional ways, at a “distance” from the college campus proper.

For such “distance” students, the same worksheets, lab activities, exams, and academic standards still apply. Instead of working in small groups and in teams to complete theory and lab sections, though, students participating in an alternative fashion must do all the work themselves. Participation via teleconferencing, video- or audio-recorded small-group sessions, and such is encouraged and supported.

There is no recording of hours attended or tardiness for students participating in this manner. The pace of the course is likewise determined by the “distance” student. Experience has shown that it is a benefit for “distance” students to maintain the same pace as their on-campus classmates whenever possible.

In lieu of small-group activities and class discussions, comprehension of the theory portion of each course will be ensured by completing and submitting detailed answers for *all* worksheet questions, not just passing daily quizzes as is the standard for conventional students. The instructor will discuss any incomplete and/or incorrect worksheet answers with the student, and ask that those questions be re-answered by the student to correct any misunderstandings before moving on.

Labwork is perhaps the most difficult portion of the curriculum for a “distance” student to complete, since the equipment used in Instrumentation is typically too large and expensive to leave the school lab facility. “Distance” students must find a way to complete the required lab activities, either by arranging time in the school lab facility and/or completing activities on equivalent equipment outside of school (e.g. at their place of employment, if applicable). Labwork completed outside of school must be validated by a supervisor and/or documented via photograph or videorecording.

Conventional students may opt to switch to “distance” mode at any time. This has proven to be a benefit to students whose lives are disrupted by catastrophic events. Likewise, “distance” students may switch back to conventional mode if and when their schedules permit. Although the existence of alternative modes of student participation is a great benefit for students with challenging schedules, it requires a greater investment of time and a greater level of self-discipline than the traditional mode where the student attends school for 6 hours every day. No student should consider the “distance” mode of learning a way to have more free time to themselves, because they will actually spend more time engaged in the coursework than if they attend school on a regular schedule. It exists merely for the sake of those who cannot attend during regular school hours, as an alternative to course withdrawal.

## Metric prefixes and conversion constants

- **Metric prefixes**

- Yotta =  $10^{24}$  Symbol: Y
- Zeta =  $10^{21}$  Symbol: Z
- Exa =  $10^{18}$  Symbol: E
- Peta =  $10^{15}$  Symbol: P
- Tera =  $10^{12}$  Symbol: T
- Giga =  $10^9$  Symbol: G
- Mega =  $10^6$  Symbol: M
- Kilo =  $10^3$  Symbol: k
- Hecto =  $10^2$  Symbol: h
- Deca =  $10^1$  Symbol: da
- Deci =  $10^{-1}$  Symbol: d
- Centi =  $10^{-2}$  Symbol: c
- Milli =  $10^{-3}$  Symbol: m
- Micro =  $10^{-6}$  Symbol:  $\mu$
- Nano =  $10^{-9}$  Symbol: n
- Pico =  $10^{-12}$  Symbol: p
- Femto =  $10^{-15}$  Symbol: f
- Atto =  $10^{-18}$  Symbol: a
- Zepto =  $10^{-21}$  Symbol: z
- Yocto =  $10^{-24}$  Symbol: y

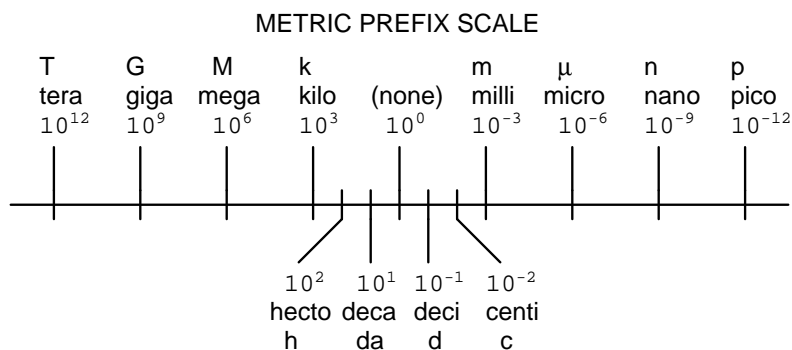

- **Conversion formulae for temperature**

- $^{\circ}\text{F} = (^{\circ}\text{C})(9/5) + 32$
- $^{\circ}\text{C} = (^{\circ}\text{F} - 32)(5/9)$
- $^{\circ}\text{R} = ^{\circ}\text{F} + 459.67$
- $\text{K} = ^{\circ}\text{C} + 273.15$

**Conversion equivalencies for distance**

- 1 inch (in) = 2.540000 centimeter (cm)
- 1 foot (ft) = 12 inches (in)
- 1 yard (yd) = 3 feet (ft)
- 1 mile (mi) = 5280 feet (ft)

### Conversion equivalencies for volume

1 gallon (gal) = 231.0 cubic inches (in<sup>3</sup>) = 4 quarts (qt) = 8 pints (pt) = 128 fluid ounces (fl. oz.) = 3.7854 liters (l)

1 milliliter (ml) = 1 cubic centimeter (cm<sup>3</sup>)

### Conversion equivalencies for velocity

1 mile per hour (mi/h) = 88 feet per minute (ft/m) = 1.46667 feet per second (ft/s) = 1.60934 kilometer per hour (km/h) = 0.44704 meter per second (m/s) = 0.868976 knot (knot – international)

### Conversion equivalencies for mass

1 pound (lbm) = 0.45359 kilogram (kg) = 0.031081 slugs

### Conversion equivalencies for force

1 pound-force (lbf) = 4.44822 newton (N)

### Conversion equivalencies for area

1 acre = 43560 square feet (ft<sup>2</sup>) = 4840 square yards (yd<sup>2</sup>) = 4046.86 square meters (m<sup>2</sup>)

### Conversion equivalencies for common pressure units (either all gauge or all absolute)

1 pound per square inch (PSI) = 2.03602 inches of mercury (in. Hg) = 27.6799 inches of water (in. W.C.) = 6.894757 kilo-pascals (kPa) = 0.06894757 bar

1 bar = 100 kilo-pascals (kPa) = 14.504 pounds per square inch (PSI)

### Conversion equivalencies for absolute pressure units (only)

1 atmosphere (Atm) = 14.7 pounds per square inch absolute (PSIA) = 101.325 kilo-pascals absolute (kPaA) = 1.01325 bar (bar) = 760 millimeters of mercury absolute (mmHgA) = 760 torr (torr)

### Conversion equivalencies for energy or work

1 british thermal unit (Btu – “International Table”) = 251.996 calories (cal – “International Table”) = 1055.06 joules (J) = 1055.06 watt-seconds (W-s) = 0.293071 watt-hour (W-hr) = 1.05506 x 10<sup>10</sup> ergs (erg) = 778.169 foot-pound-force (ft-lbf)

### Conversion equivalencies for power

1 horsepower (hp – 550 ft-lbf/s) = 745.7 watts (W) = 2544.43 british thermal units per hour (Btu/hr) = 0.0760181 boiler horsepower (hp – boiler)

### Acceleration of gravity (free fall), Earth standard

9.806650 meters per second per second (m/s<sup>2</sup>) = 32.1740 feet per second per second (ft/s<sup>2</sup>)

### Physical constants

Speed of light in a vacuum ( $c$ ) =  $2.9979 \times 10^8$  meters per second (m/s) = 186,281 miles per second (mi/s)

Avogadro's number ( $N_A$ ) =  $6.022 \times 10^{23}$  per mole ( $\text{mol}^{-1}$ )

Electronic charge ( $e$ ) =  $1.602 \times 10^{-19}$  Coulomb (C)

Boltzmann's constant ( $k$ ) =  $1.38 \times 10^{-23}$  Joules per Kelvin (J/K)

Stefan-Boltzmann constant ( $\sigma$ ) =  $5.67 \times 10^{-8}$  Watts per square meter-Kelvin<sup>4</sup> ( $\text{W}/\text{m}^2 \cdot \text{K}^4$ )

Molar gas constant ( $R$ ) = 8.314 Joules per mole-Kelvin (J/mol-K)

### Properties of Water

Freezing point at sea level =  $32^\circ\text{F} = 0^\circ\text{C}$

Boiling point at sea level =  $212^\circ\text{F} = 100^\circ\text{C}$

Density of water at  $4^\circ\text{C} = 1000 \text{ kg}/\text{m}^3 = 1 \text{ g}/\text{cm}^3 = 1 \text{ kg}/\text{liter} = 62.428 \text{ lb}/\text{ft}^3 = 1.94 \text{ slugs}/\text{ft}^3$

Specific heat of water at  $14^\circ\text{C} = 1.00002 \text{ calories}/\text{g} \cdot ^\circ\text{C} = 1 \text{ BTU}/\text{lb} \cdot ^\circ\text{F} = 4.1869 \text{ Joules}/\text{g} \cdot ^\circ\text{C}$

Specific heat of ice  $\approx 0.5 \text{ calories}/\text{g} \cdot ^\circ\text{C}$

Specific heat of steam  $\approx 0.48 \text{ calories}/\text{g} \cdot ^\circ\text{C}$

Absolute viscosity of water at  $20^\circ\text{C} = 1.0019 \text{ centipoise (cp)} = 0.0010019 \text{ Pascal-seconds (Pa}\cdot\text{s)}$

Surface tension of water (in contact with air) at  $18^\circ\text{C} = 73.05 \text{ dynes}/\text{cm}$

pH of pure water at  $25^\circ\text{C} = 7.0$  (*pH scale = 0 to 14*)

### Properties of Dry Air at sea level

Density of dry air at  $20^\circ\text{C}$  and 760 torr =  $1.204 \text{ mg}/\text{cm}^3 = 1.204 \text{ kg}/\text{m}^3 = 0.075 \text{ lb}/\text{ft}^3 = 0.00235 \text{ slugs}/\text{ft}^3$

Absolute viscosity of dry air at  $20^\circ\text{C}$  and 760 torr =  $0.018 \text{ centipoise (cp)} = 1.8 \times 10^{-5} \text{ Pascal-seconds (Pa}\cdot\text{s)}$

file conversion\_constants

### How to get the most out of academic reading:

- Articulate your thoughts as you read (i.e. “have a conversation” with the author). This will develop *metacognition*: active supervision of your own thoughts. Write your thoughts as you read, noting points of agreement, disagreement, confusion, epiphanies, and connections between different concepts or applications. These notes should also document important math formulae, explaining in your own words what each formula means and the proper units of measurement used.
- Outline, don’t highlight! Writing your own summary or outline is a far more effective way to comprehend a text than simply underlining and highlighting key words. A suggested ratio is one sentence of your own thoughts per paragraph of text read. Note points of disagreement or confusion to explore later.
- Work through all mathematical exercises shown within the text, to ensure you understand all the steps.
- Imagine explaining concepts you’ve just learned to someone else. Teaching forces you to distill concepts to their essence, thereby clarifying those concepts, revealing assumptions, and exposing misconceptions. Your goal is to create the simplest explanation that is still technically accurate.
- Write your own questions based on what you read, as though you are a teacher preparing to test students’ comprehension of the subject matter.

### How to effectively problem-solve and troubleshoot:

- Rely on principles, not procedures. Don’t be satisfied with memorizing steps – learn *why* those steps work. Each one should make logical sense and have real-world meaning to you.
- Sketch a diagram to help visualize the problem. Sketch a graph showing how variables relate. When building a real system, always prototype it on paper and analyze its function *before* constructing it.
- Identify what it is you need to solve, identify all relevant data, identify all units of measurement, identify any general principles or formulae linking the given information to the solution, and then identify any “missing pieces” to a solution. Annotate all diagrams with this data.
- Perform “thought experiments” to explore the effects of different conditions for theoretical problems. When troubleshooting, perform *diagnostic tests* rather than just visually inspect for faults.
- Simplify the problem and solve that simplified problem to identify strategies applicable to the original problem (e.g. change quantitative to qualitative, or visa-versa; substitute easier numerical values; eliminate confusing details; add details to eliminate unknowns; consider simple limiting cases; apply an analogy). Often you can add or remove components in a malfunctioning system to simplify it as well and better identify the nature and location of the problem.
- Work “backward” from a hypothetical solution to a new set of given conditions.

### How to manage your time:

- Avoid procrastination. Work now and play later, or else you will create trouble for yourself. Schedule your work appropriate to the *place* you’re in as well: e.g. don’t waste lab time doing things that could be done anywhere else, when there is work to be done that requires the lab.
- Eliminate distractions. Kill your television and video games. Study in places where you can concentrate.
- Use your “in between” time productively. Don’t leave campus for lunch. Arrive to school early. If you finish your assigned work early, begin working on the next assignment.

**Above all, cultivate persistence.** Persistent effort is necessary to master anything non-trivial. The keys to persistence are (1) having the desire to achieve that mastery, and (2) realizing challenges are normal and not an indication of something gone wrong. A common error is to equate *easy* with *effective*: students often believe learning should be easy if everything is done right. The truth is that mastery never comes easy!

file question0

## Creative Commons License

This worksheet is licensed under the **Creative Commons Attribution 4.0 International Public License**. To view a copy of this license, visit <http://creativecommons.org/licenses/by/4.0/> or send a letter to Creative Commons, 171 Second Street, Suite 300, San Francisco, California 94105, USA. The terms and conditions of this license allow for free copying, distribution, and/or modification of all licensed works by the general public.

### Simple explanation of Attribution License:

The licensor (Tony Kuphaldt) permits others to copy, distribute, display, and otherwise use this work. In return, licensees must give the original author(s) credit. For the full license text, please visit <http://creativecommons.org/licenses/by/4.0/> on the internet.

### More detailed explanation of Attribution License:

Under the terms and conditions of the Creative Commons Attribution License, you may make freely use, make copies, and even modify these worksheets (and the individual “source” files comprising them) without having to ask me (the author and licensor) for permission. The one thing you must do is properly credit my original authorship. Basically, this protects my efforts against plagiarism without hindering the end-user as would normally be the case under full copyright protection. This gives educators a great deal of freedom in how they might adapt my learning materials to their unique needs, removing all financial and legal barriers which would normally hinder if not prevent creative use.

Nothing in the License prohibits the sale of original or adapted materials by others. You are free to copy what I have created, modify them if you please (or not), and then sell them at any price. Once again, the only catch is that you must give proper credit to myself as the original author and licensor. Given that these worksheets will be continually made available on the internet for free download, though, few people will pay for what you are selling unless you have somehow added value.

Nothing in the License prohibits the application of a more restrictive license (or no license at all) to derivative works. This means you can add your own content to that which I have made, and then exercise full copyright restriction over the new (derivative) work, choosing not to release your additions under the same free and open terms. An example of where you might wish to do this is if you are a teacher who desires to add a detailed “answer key” for your own benefit but *not* to make this answer key available to anyone else (e.g. students).

Note: the text on this page is not a license. It is simply a handy reference for understanding the Legal Code (the full license) - it is a human-readable expression of some of its key terms. Think of it as the user-friendly interface to the Legal Code beneath. This simple explanation itself has no legal value, and its contents do not appear in the actual license.

[file license](#)

## Questions

---

### Question 1

Read and outline the “Normal’ Status of a Switch” section of the “Discrete Process Measurement” chapter in your *Lessons In Industrial Instrumentation* textbook.

The purpose of your outline is to foster close reading of the text, to facilitate quick referencing of specific points within the text, to record questions of your own, and to practice clear writing. Your outline must meet the following standards for full credit: *every major idea contained in the text represented in your outline, entirely in your own words (i.e. no copying of text), written in a legible and comprehensible manner, of sufficient quality that others would find it informative.* Incomplete, illegible, cryptic, and/or plagiarized outlines will not receive full credit. A suggestion is one sentence of your own per paragraph of source text. Helpful additions include:

- Noting questions or points of confusion you have from the reading
- Page numbers from the source text for quick reference during discussion
- Images copied from the text (or sketched by you) to illustrate concepts
- References to previously learned concepts

Note: this is a subject of much confusion for students, especially with regard to *process* switches such as pressure, level, temperature, and flow switches. A special practice worksheet has been made for students on this very subject called “Process Switches and Switch Circuits” available on the Socratic Instrumentation website.

[file i04501](#)

---

### Question 2

Read and outline the “Hand Switches” and “Limit Switches” sections of the “Discrete Process Measurement” chapter in your *Lessons In Industrial Instrumentation* textbook.

The purpose of your outline is to foster close reading of the text, to facilitate quick referencing of specific points within the text, to record questions of your own, and to practice clear writing. Your outline must meet the following standards for full credit: *every major idea contained in the text represented in your outline, entirely in your own words (i.e. no copying of text), written in a legible and comprehensible manner, of sufficient quality that others would find it informative.* Incomplete, illegible, cryptic, and/or plagiarized outlines will not receive full credit. A suggestion is one sentence of your own per paragraph of source text. Helpful additions include:

- Noting questions or points of confusion you have from the reading
- Page numbers from the source text for quick reference during discussion
- Images copied from the text (or sketched by you) to illustrate concepts
- References to previously learned concepts

[file i04502](#)

---

### Question 3

Read and outline the “Proximity Switches” section of the “Discrete Process Measurement” chapter in your *Lessons In Industrial Instrumentation* textbook.

The purpose of your outline is to foster close reading of the text, to facilitate quick referencing of specific points within the text, to record questions of your own, and to practice clear writing. Your outline must meet the following standards for full credit: *every major idea contained in the text represented in your outline, entirely in your own words (i.e. no copying of text), written in a legible and comprehensible manner, of sufficient quality that others would find it informative.* Incomplete, illegible, cryptic, and/or plagiarized outlines will not receive full credit. A suggestion is one sentence of your own per paragraph of source text. Helpful additions include:

- Noting questions or points of confusion you have from the reading
- Page numbers from the source text for quick reference during discussion
- Images copied from the text (or sketched by you) to illustrate concepts
- References to previously learned concepts

[file i04503](#)



#### Question 4

An improvement over direct-contact limit switches for many applications is the *inductive proximity switch*. This type of switch actuates simply when an object gets *near* it – no direct physical contact necessary! Explain how these devices work, and what kinds of material they are able to detect.

Inductive proximity switches are powered devices by necessity. They usually require a DC voltage for power, and their output is usually *not* a dry switch contact. Instead, it is usually a transistor, with the output signal being standard TTL logic (0 to 5 volts). Inductive proximity switches are often manufactured as three-wire devices:

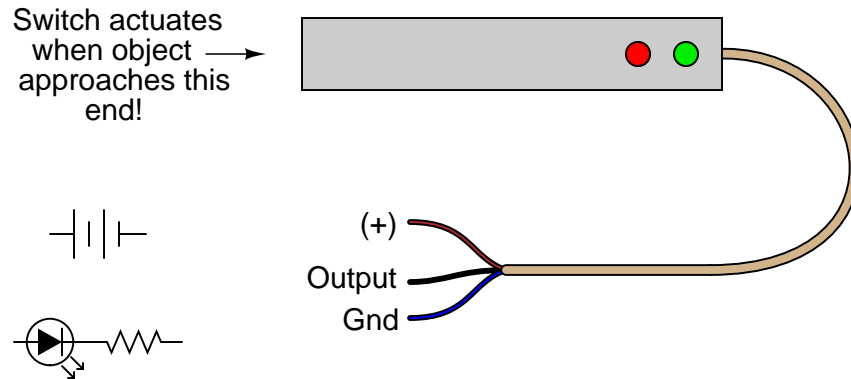

Show how you would connect the limit switch in the above illustration so that it makes the LED turn *on* when actuated, assuming the switch's internal transistor is configured to *sink* current through the output lead.

#### Suggestions for Socratic discussion

- Identify an object an inductive proximity switch would be able to detect.
- Identify an object an optical proximity switch would be able to detect.
- Identify an object a capacitive proximity switch would *not* be able to detect.
- Identify an object an ultrasonic proximity switch would *not* be able to detect.

[file i02244](#)

---

### Question 5

Read and outline the “Pressure Switches” section of the “Discrete Process Measurement” chapter in your *Lessons In Industrial Instrumentation* textbook.

The purpose of your outline is to foster close reading of the text, to facilitate quick referencing of specific points within the text, to record questions of your own, and to practice clear writing. Your outline must meet the following standards for full credit: *every major idea contained in the text represented in your outline, entirely in your own words (i.e. no copying of text), written in a legible and comprehensible manner, of sufficient quality that others would find it informative.* Incomplete, illegible, cryptic, and/or plagiarized outlines will not receive full credit. A suggestion is one sentence of your own per paragraph of source text. Helpful additions include:

- Noting questions or points of confusion you have from the reading
- Page numbers from the source text for quick reference during discussion
- Images copied from the text (or sketched by you) to illustrate concepts
- References to previously learned concepts

[file i03934](#)

### Question 6

Determine the functions of all pressure switches and relays in this steam boiler monitoring circuit, and what each of their designations mean:

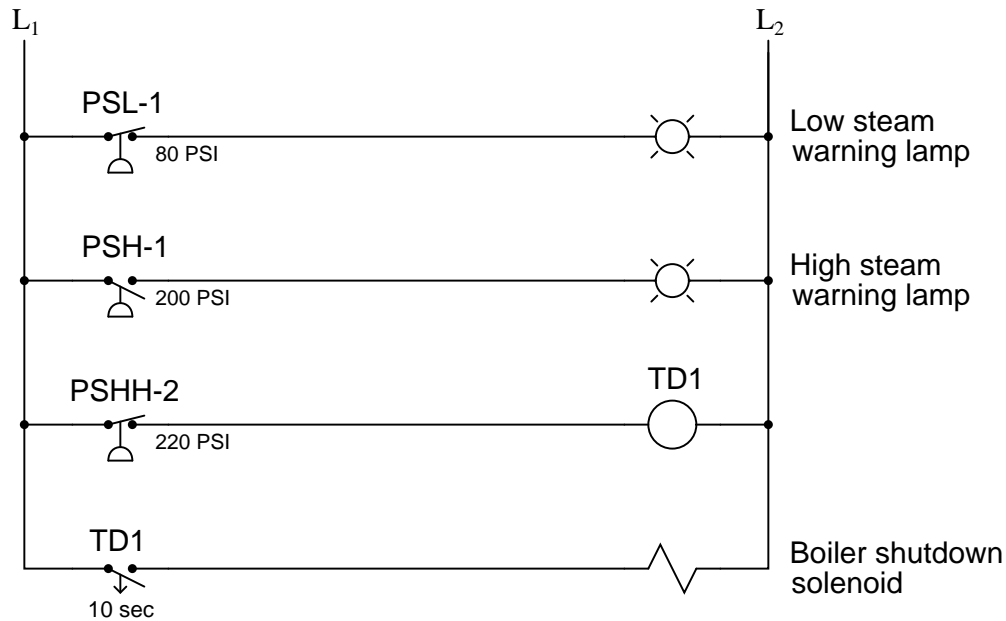

Also, explain the significance of the switch symbols: normally open versus normally closed. The time-delay relay (TD1) is especially important here!

Finally, add a “Lamp Test” pushbutton switch to this circuit which will force all lamps to energize when pressed, in order to test the proper operation of the lamps without waiting for an abnormal process condition to occur.

#### Suggestions for Socratic discussion

- Why do you suppose a time-delay relay is used in this particular control application?
- Is the boiler shutdown solenoid *energize-to-trip* or *de-energize-to-trip*? Explain how we can tell from an examination of the schematic.
- Identify where in this circuit you could install a PSHHH (pressure switch high-high-high) that would trip the boiler immediately.
- Identify a circuit fault that would cause the boiler to needlessly shut down (a “safe” fault).
- Identify a circuit fault that would cause the boiler to not be able to shut down when it needs to (a “dangerous” fault).

file i00221



Question 8

A form of liquid level switch called a *tilt switch* is often used for detecting sewage level in “lift stations” where sewage collected from homes via gravity is pumped out of the collection sump to the wastewater treatment plant (usually located miles away):

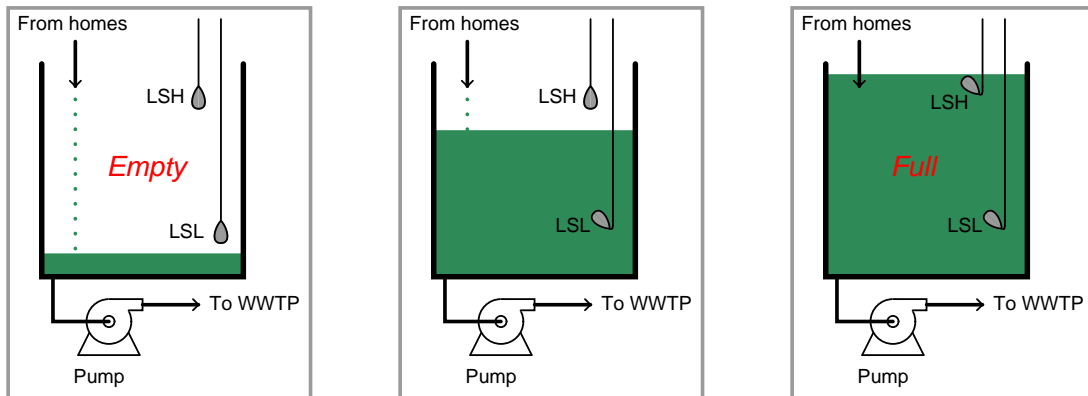

Tilt switches often use a small glass vial containing liquid mercury as the tilt sensor. Explain how a glass tube partially filled with mercury works as an electrical tilt switch, and also perform a “thought experiment” where you describe this system’s function from start to finish through a complete start-stop cycle of the pump motor:

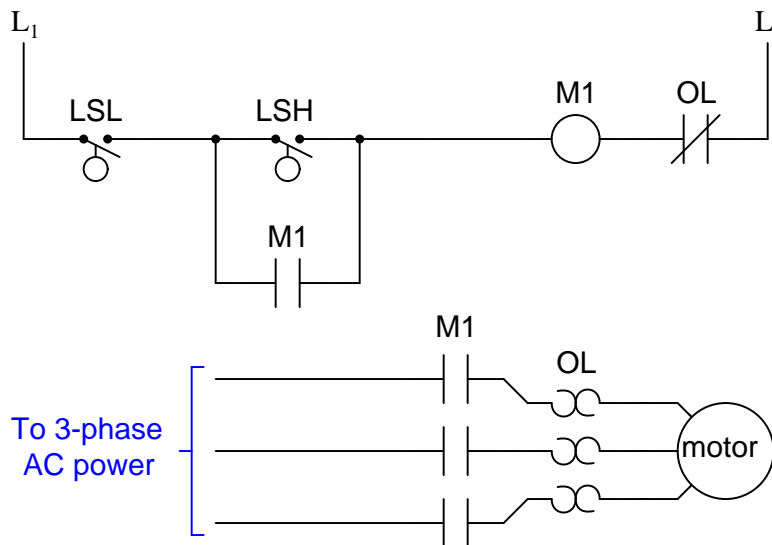

**Suggestions for Socratic discussion**

- What would happen if the OL switch failed open in this system?
- What would happen if the LSL switch failed open in this system?
- What would happen if the LSH switch failed open in this system?
- What would happen if the LSL switch failed shorted in this system?
- What would happen if the LSH switch failed shorted in this system?
- What would happen if the LSH switch failed shorted in this system?

- What would happen if the M1 seal-in contact failed open in this system?
- What would happen if the M1 seal-in contact failed shorted in this system?

[file i00303](#)

Question 9

Examine this ladder diagram for a solenoid valve control circuit, where the status of a solenoid valve (either on or off) is controlled by hand switches and a pressure switch.

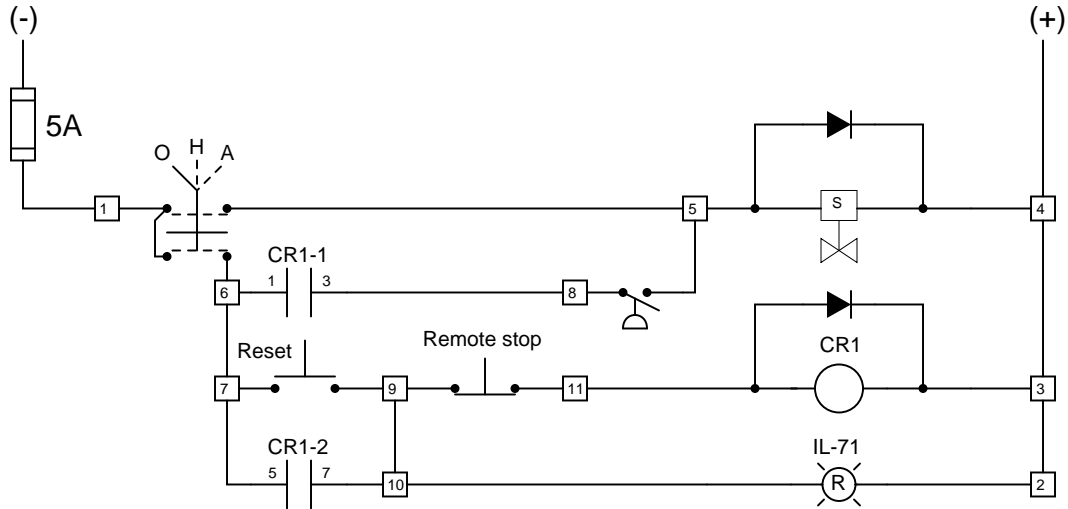

Suppose the solenoid valve refuses to energize when the Hand/Off/Auto switch has been placed in “Auto,” the Reset pushbutton pressed, and a high-pressure condition exists. The solenoid can, however, be made to energize by placing the switch in the “Hand” position.

Beginning your troubleshooting steps, you first note that the red indicator light never comes on. Identify at least three possible faults that could (each one, individually) account for these symptoms. Also, identify at least three components you know to be fully functional in this circuit.

Three possible faults:

- 
- 
- 

Three known-good components:

- 
- 
- 

[file i04158](#)

---

### Question 10

Using a terminal strip to organize all wire connections, construct a circuit to turn on a DC load (e.g. lamp, relay coil) using a **proximity switch** as the sensor. The instructor will provide all necessary components to you during class time. Be sure to bring appropriate tools to class for this exercise (e.g. Phillips and slotted screwdrivers, multimeter).

#### Suggestions for Socratic discussion

- A problem-solving technique useful for constructing circuits is to *sketch a schematic diagram of the intended circuit* before making a single connection. This important step not only helps you to identify potential problems before they arise, but is also useful when constructing circuits as a team because it prompts all team members to exchange ideas and ask questions before committing to a plan of action.
- Is your proximity switch NO or NC? How can you tell?
- Is your proximity switch sourcing or sinking? How can you tell?
- What are some of the advantages that proximity switches have over traditional direct-contact limit switches?
- What are some good applications where we could use proximity switches in industry?
- Suppose you needed to make a DC proximity switch (with transistor output) switch power to an *AC* load. How could you accomplish this function, since the proximity switch can only handle DC, not AC?

[file i04504](#)

## Question 11

An improvement over direct-contact limit switches for many applications is the *inductive proximity switch*. This type of switch actuates simply when an object gets *near* it – no direct physical contact necessary! Explain how these devices work, and what kinds of material they are able to detect.

Inductive proximity switches are powered devices by necessity. They usually require a DC voltage for power, and their output is usually *not* a dry switch contact. Instead, it is usually a transistor, with the output signal being standard TTL logic (0 to 5 volts). Inductive proximity switches are often manufactured as three-wire devices:

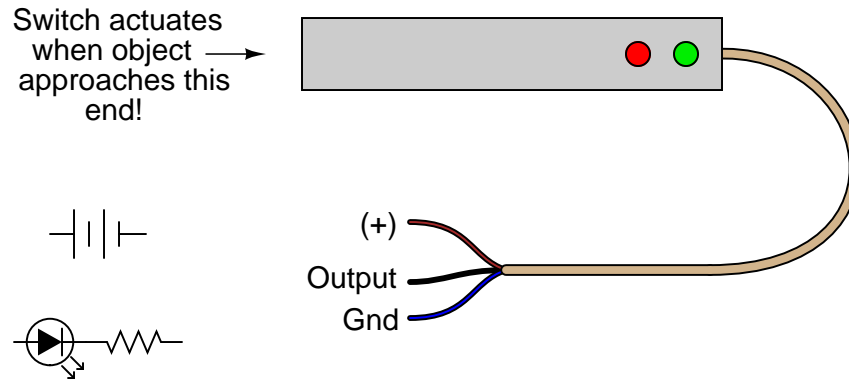

Show how you would connect the limit switch in the above illustration so that it makes the LED turn *on* when actuated, assuming the switch's internal transistor is configured to *source* current through the output lead.

### Suggestions for Socratic discussion

- Identify an object a capacitive proximity switch would be able to detect.
- Identify an object an ultrasonic proximity switch would be able to detect.
- Identify an object an inductive proximity switch would *not* be able to detect.
- Identify an object an optical proximity switch would *not* be able to detect.

[file i02243](#)



Question 12

Switches, whether they be hand-actuated or actuated by a physical process, come in two varieties: *normally-open* (NO) and *normally-closed* (NC). You are probably accustomed to seeing both types of switch represented in pushbutton form on schematic diagrams:

*Normally-open*  
pushbutton switch

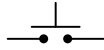

*Normally-closed*  
pushbutton switch

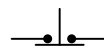

*Normally-open* pushbutton switches close (pass current) when actuated (pressed). When un-actuated, they return to their “normal” (open) state.

*Normally-closed* pushbutton switches are just the opposite: they open (stop current) when actuated (pressed) and return to their “normal” (closed, passing current) state when un-actuated.

This is simple enough to comprehend: the “normal” status of a momentary-contact pushbutton switch is the state it is in when no one is touching it. When pressed, the pushbutton switch goes to the other (opposite) state.

Things get more confusing, though, when we examine *process switches*, such as pressure switches, level switches, temperature switches, and flow switches:

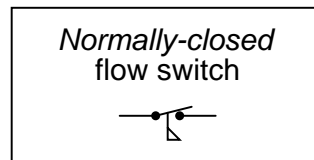
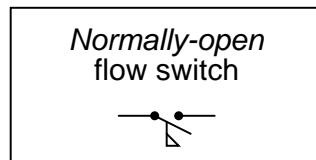
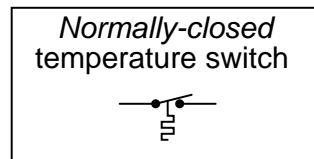
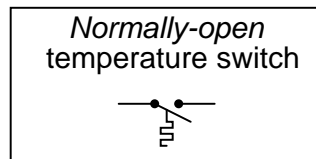
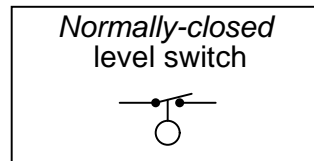
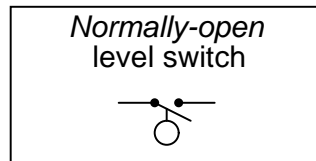
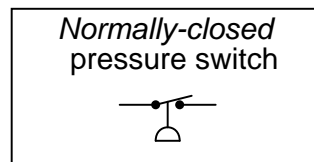
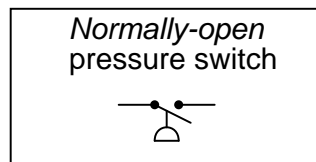

Define “normal” for each of these process switches. In other words, explain what condition(s) each process switch must be in to ensure it is in the “normal” state; and conversely, what condition(s) need to be applied to each switch to force it into its other state.

[file i02966](#)

---

Question 13

*Limit switches* are electrical switches designed to actuate based on the motion or position of an object, rather than the touch of a human operator. Simple limit switches rely on direct, physical contact, using a lever, sometimes tipped with a roller for low friction:

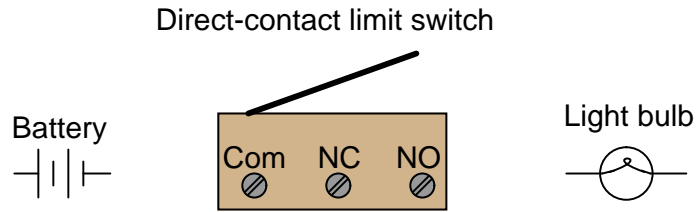

Show how you would connect the limit switch in the above illustration so that it makes the light turn *off* when actuated (i.e. the light will be on when no one touches the switch lever).

[file i02242](#)

---

Question 14

Below is an illustration of a diaphragm-operated *pressure switch*, designed to actuate when the process fluid pressure applied to the impulse line (tube) exceeds a certain set value. A schematic diagram shows how the switch contacts relate to the screw terminals seen on the outside of the switch illustration:

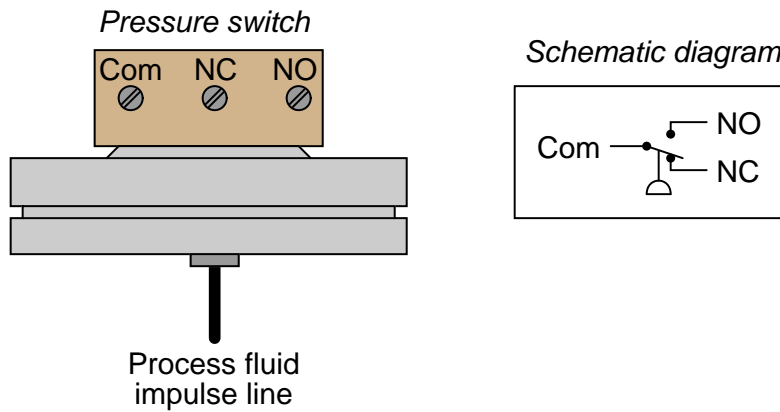

Explain what is meant by the “normally-closed” (NC) and “normally-open” (NO) labels next to two of the electrical screw terminals. Identify the status of the switch when process pressure exceeds the switch’s set value.

[file i00222](#)

---

Question 15

Two pressure switches are plumbed together so as to receive the exact same pressure at all times, and they both sense the pressure of compressed air in a pneumatic system. Based on the wiring diagram for these switches, identify the function of the lamp:

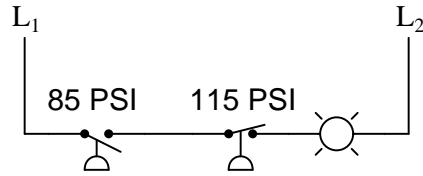

[file i02964](#)

---

Question 16

Identify which lamp in the following ladder-logic diagram is the *high-flow* alarm and which is the *low-flow* alarm, given the flow switch symbols shown:

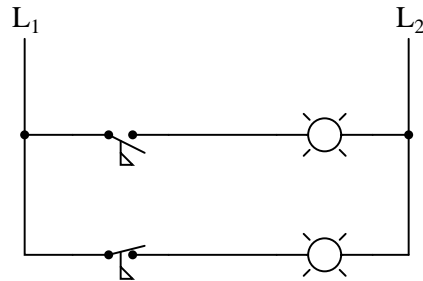

[file i00548](#)

---

Question 17

Label the components in this ladder diagram for a pressure alarm circuit, identifying the following:

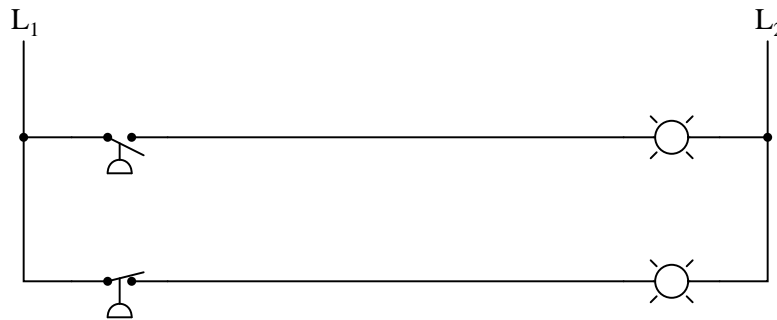

- Which lamp is the *low pressure* warning lamp
- Which lamp is the *high pressure* warning lamp
- Which pressure switch should have the low-pressure trip point of 10 PSI
- Which pressure switch should have the high-pressure trip point of 250 PSI

[file i03967](#)

Question 18

Identify the state of the light bulb when the normally-closed pressure switch contact *opens*:

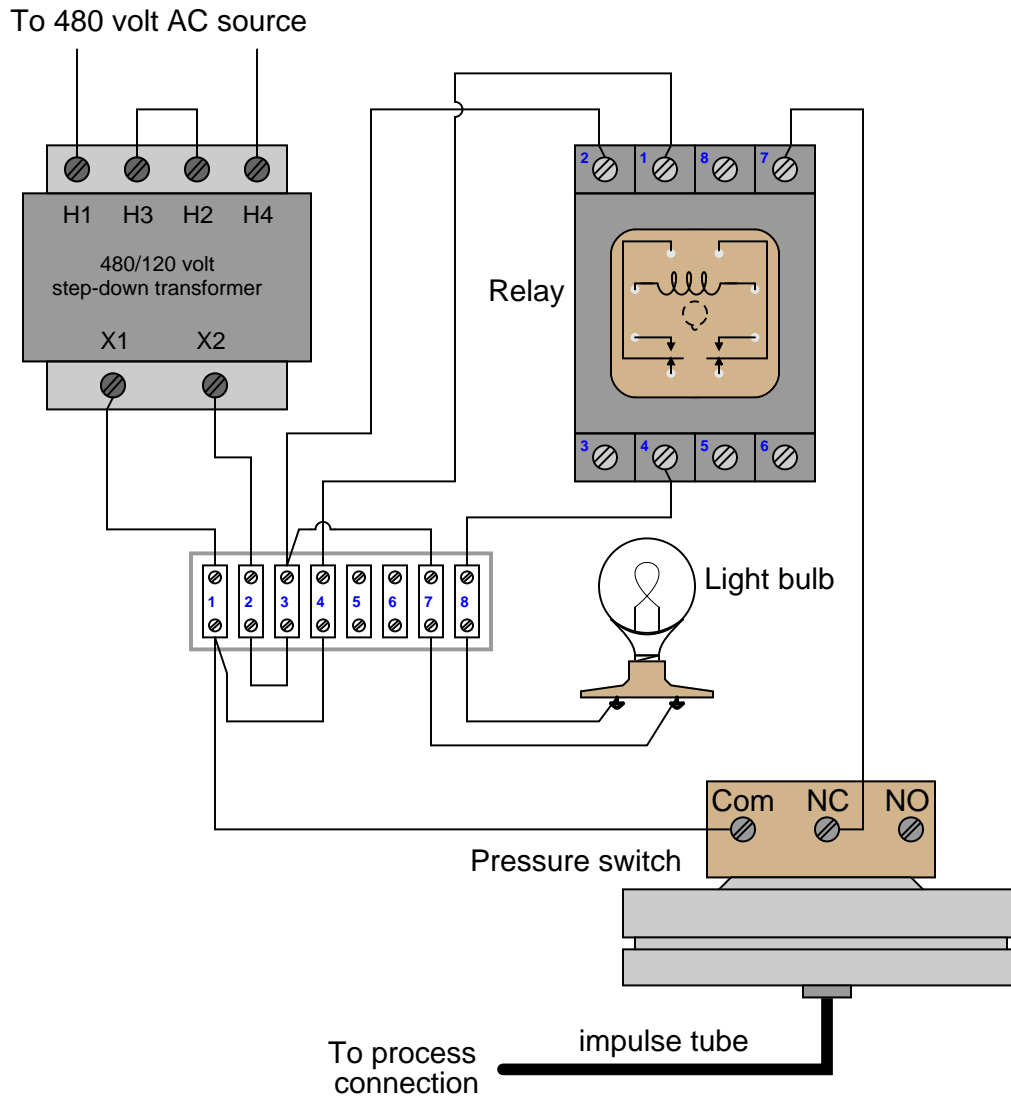

Assuming the light bulb functions as a pressure alarm to alert operators to an unsafe condition, determine whether this is a *low-pressure* alarm or a *high pressure* alarm.

Hint: remember that the “normal” status of a switch is defined as the status of *minimum stimulus*: when the switch is exposed to the lowest possible degree of process stimulation (in this particular case, to the lowest possible pressure).

[file i03204](#)

---

## Question 19

Large shut-off valves used on oil and gas pipelines are often opened and closed by electric valve actuators. Such valve actuators are often used in remote locations where other sources of power such as compressed air are not available. Electric valve actuators are also frequently used in water treatment facilities, both for actuating valves and also large gates, weirs, and other water-directing machinery.

Examine the schematic diagram on page 21 of the Limatorque L120 series actuator (L120-10 through L120-40) manual published by FlowServe (document FCD LMENIM1201-01, 07/06), and answer the following questions:

Identify how the direction of the motor's rotation is controlled. Specifically, explain what must happen to make the motor spin in the "open" direction versus the "closed" direction.

Explain what the lettered "taps" on the control power transformer (CPT) are used for. Under what circumstances do you think a technician would need to change the tap connections here, if ever?

Just to the left of each motor contactor coil is a normally-closed contact linked to the *other* contactor. Explain the purpose of these contacts.

How does each contactor latch itself in and keep running after its respective "start" pushbutton switch has been released?

Identify how to wire "remote" Stop, Open, and Close pushbutton switches to this actuator, so that it may be operated from a remote location instead of directly at the actuator.

### **Suggestions for Socratic discussion**

- What advantages do electrically-actuated valves enjoy over pneumatically-actuated valves, besides not needing a compressed air supply?
- What advantages do pneumatically-actuated valves enjoy over electrically-actuated valves?
- Suppose a model L120 actuator were shipped to you from the factory configured for 380 volt operation. What would you have to change in order to adapt it to work on 480 volts?

[file i02339](#)

## Question 20

Electrically-powered air compressors are commonly used in many different industries for supplying clean, dry compressed air to machines, instrument systems, and pneumatic tools. A simple compressor system consists of a compressor which works much like a bicycle tire pump (drawing in air, then compressing it using pistons), an electric motor to turn the compressor mechanism via a V-belt, a “receiver tank” to receive the compressed air discharged by the compressor mechanism, and some miscellaneous components installed to control the pressure of the compressed air in the receiver tank and drain any condensed water vapor that enters the receiver:

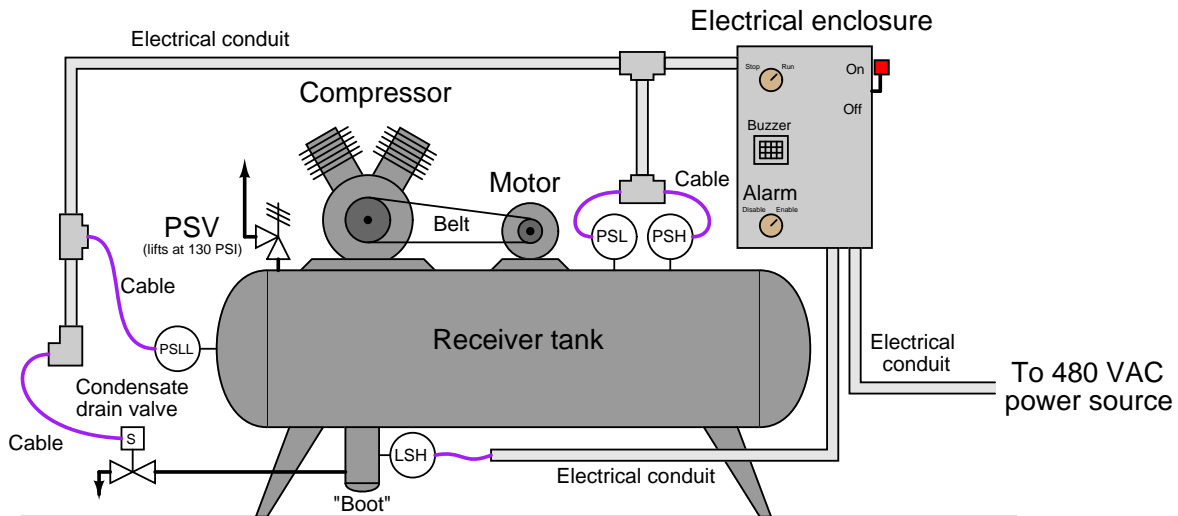

Electromechanical relay circuitry located inside the electrical enclosure decides when to turn the compressor motor on and off based on the statuses of the high- and low-pressure control switches (PSH = high pressure switch ; PSL = low pressure switch).

Your task is two-fold. First, you must figure out how to wire a new low-low pressure alarm switch (PSLL, shown on the left-hand end of the receiver) so that an alarm buzzer will activate if ever the compressed air pressure falls too low. A newly-installed hand switch located on the front panel of the electrical enclosure must be wired with this PSLL switch in such a way that the buzzer cannot energize if the hand switch is in the “alarm disable” position. Second, you must figure out how to wire a new high-level switch (LSH, shown on the “boot” of the receiver tank) so that the condensate drain valve will energize automatically to open up and drain water out of the receiver boot when the level gets too high, and then automatically shut again when the water in the boot drops down to an acceptable level.

The following schematic diagram shows the basic motor control circuit for this air compressor, with the new switches, buzzer, and drain valve shown unwired:

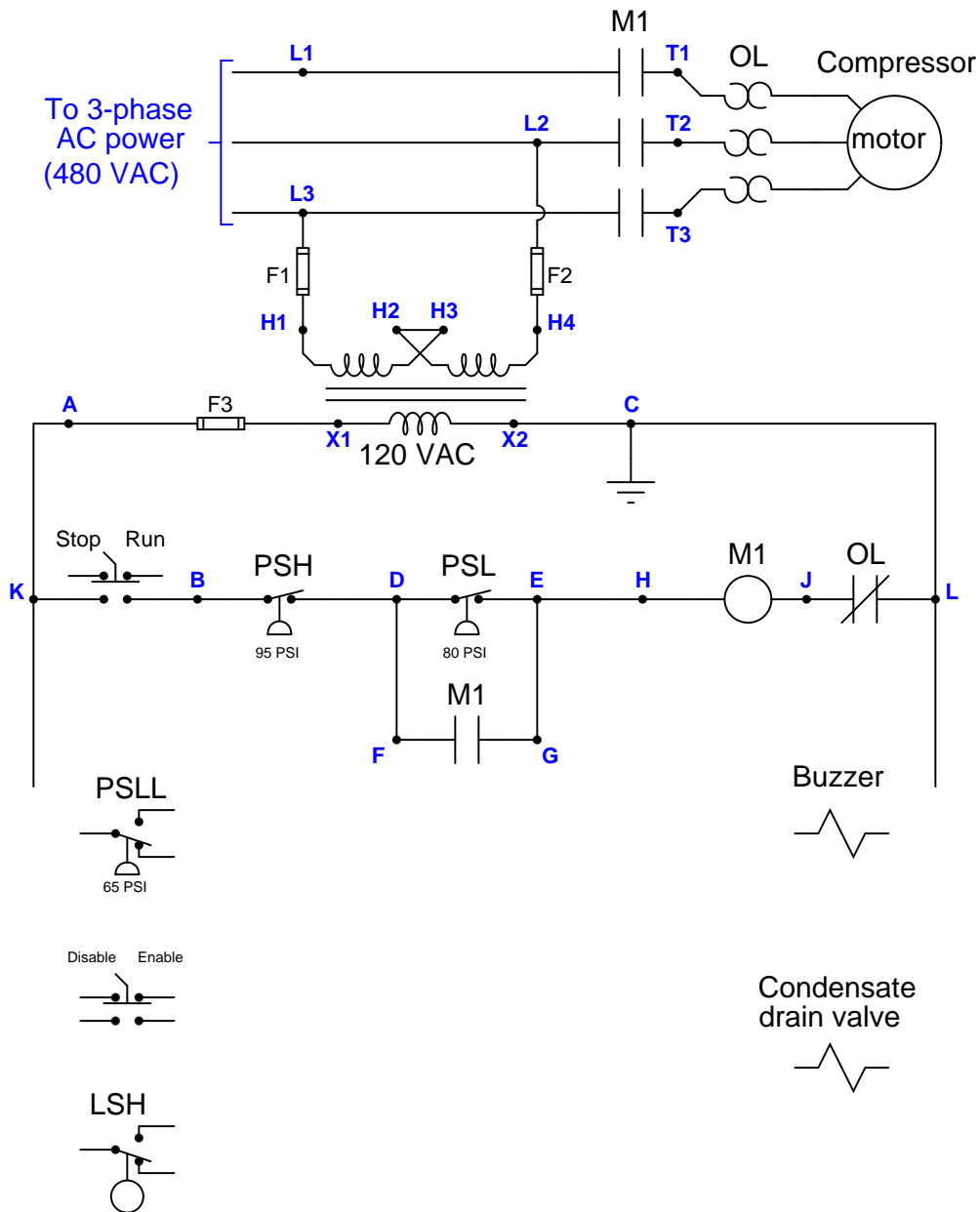

Complete this control circuit by sketching connecting wires between the new switches, buzzer, and drain valve solenoid. Remember that the way all switches are drawn in schematic diagrams is in their “normal” states as defined by the manufacturer: the *state of minimum stimulus* (when the switch is un-actuated). For pressure switches, this “normal” state occurs during a low pressure condition; for liquid level switches, this “normal” state occurs during a low-level (dry) condition. Note that each of the new process switches has SPDT contacts, allowing you to wire each one as normally-open (NO) or as normally-closed (NC) as you see fit.

[file i02540](#)

## Question 21

The most common method of starting up a three-phase induction motor is to simply apply full power all at once by closing the three contacts of a large “contactor” relay. This is called *across-the-line* starting:

### *"Across the line" motor starter*

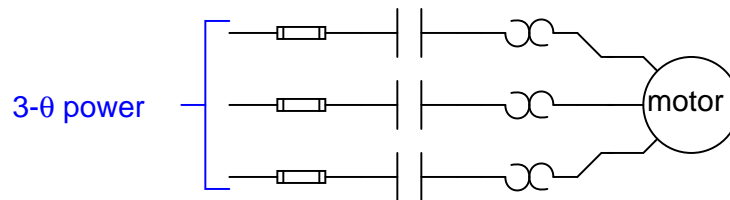

Across-the-line starting is simple, but results in huge “inrush” currents at the moment of contactor closure, and also places a lot of mechanical and thermal stress on the motor as it rushes to attain full speed.

A “gentler” method of starting an induction motor is to place impedances in series with the three-phase power, using two contactors (one “start” and one “run”) to sequence the motor from start-up to full-speed run. The impedances ideally take the form of inductors (“reactors”):

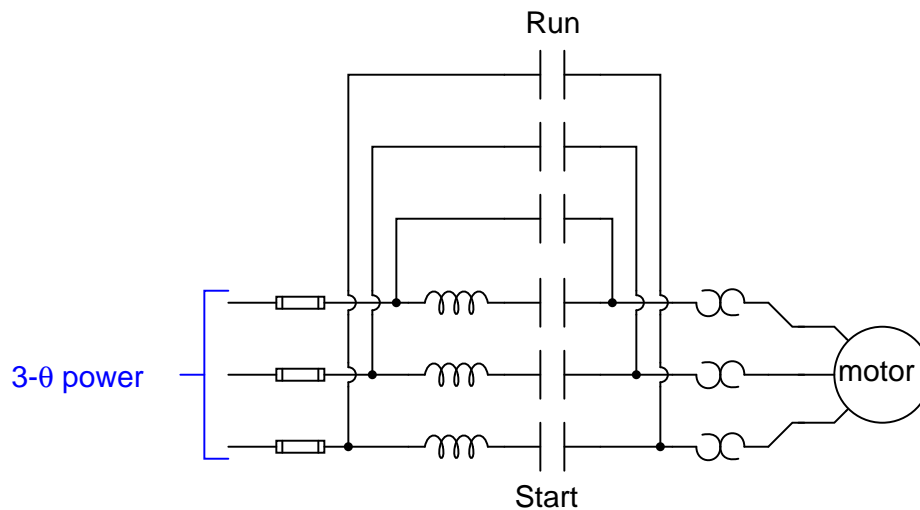

Explain how and why this method of starting is gentler than across-the-line starting.

### Suggestions for Socratic discussion

- Identify some means to *time* the closure of the two sets of power contacts (Start and Run) so that the motor is soft-started for an appropriately before having full power applied.
- Would large (high-power) resistors work instead of inductors?
- Would large capacitors work instead of inductors?
- Suppose one of the series reactors failed open. What effect(s) would this have on the circuit’s operation?

[file i02310](#)



Question 22

An interesting way to achieve reduced-voltage starting for a three-phase motor is to use a *6-lead* motor where the three stator winding sets are individually wired so as to allow either wye (start) or delta configurations:

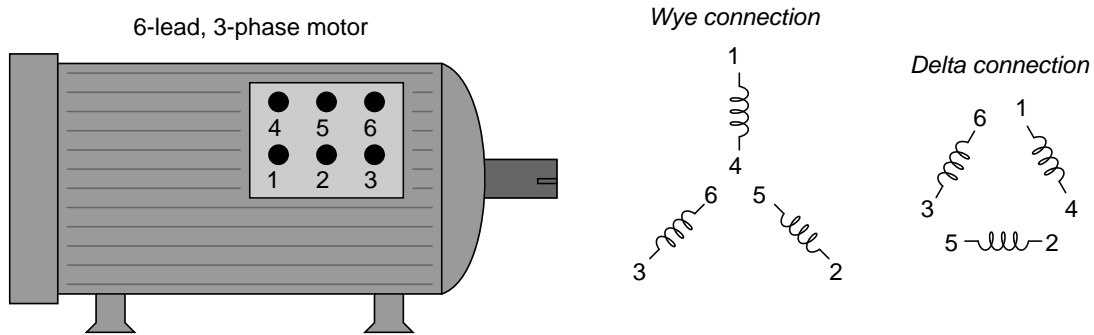

A “Start” contactor sends power to the stator windings in a wye configuration for a short start-up time (perhaps 10 seconds), then that starter disengages and a “Run” starter energizes to send power to the stator windings in a delta configuration. In the “wye” configuration, each winding receives  $\frac{1}{\sqrt{3}}$  of the line voltage. In the “delta” configuration, each winding receives the full line voltage.

Sketch the proper wire connections to create just such a “wye-delta” motor starter. Hint: terminals 1, 2, and 3 of the motor *always* connect to the three-phase power lines!

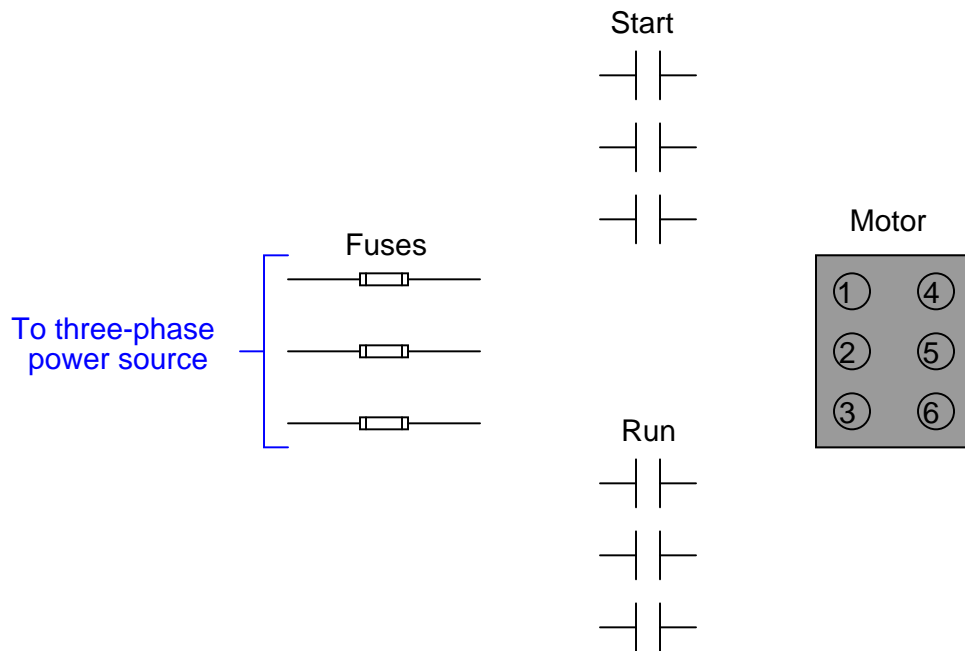

**Suggestions for Socratic discussion**

- Explain the purpose of using reduced-voltage starting for a large electric motor.

[file i03870](#)

---

### Question 23

Read portions of the Rockwell SMC-Flex motor controller Application Guide (publication 150-AT002B-EN-P, June 2004) and answer the following questions:

Devices such as the SMC-Flex motor controller are often referred to in the industry as “solid state soft-start” units. Explain what is meant by the term *soft start*, and why this feature might be desirable for large AC induction motors.

Explain how SCRs (Silicon Controlled Rectifiers) are used to provide reduced-voltage starting for any electric motor receiving its three-phase power through an SMC-Flex unit. How does this technique compare with other methods of reduced-voltage starting?

In addition to using SCRs to control motor voltage, the SMC-Flex unit also contains an *SCR bypass* contactor. Explain what this is, and under what conditions it “pulls in” (operates).

One of the additional features provided by this motor controller is something called *kickstart*. Explain what this feature is, how it works, and identify an application where it might be useful.

Find a wiring diagram for the SMC-Flex unit and identify where “Start” and “Stop” pushbutton switches may be connected to control the motor. Also identify the “normal” status for each of these switches and explain why they are like that.

#### Suggestions for Socratic discussion

- Identify some of the other useful features of this solid-state soft start unit, and explain how these features would be difficult (or impossible) to emulate using mechanical-style contactors.

[file i02991](#)

---

### Question 24

Read and outline the “AC Motor Speed Control” section of the “Variable-Speed Motor Controls” chapter in your *Lessons In Industrial Instrumentation* textbook.

The purpose of your outline is to foster close reading of the text, to facilitate quick referencing of specific points within the text, to record questions of your own, and to practice clear writing. Your outline must meet the following standards for full credit: *every major idea contained in the text represented in your outline, entirely in your own words (i.e. no copying of text), written in a legible and comprehensible manner, of sufficient quality that others would find it informative*. Incomplete, illegible, cryptic, and/or plagiarized outlines will not receive full credit. A suggestion is one sentence of your own per paragraph of source text. Helpful additions include:

- Noting questions or points of confusion you have from the reading
- Page numbers from the source text for quick reference during discussion
- Images copied from the text (or sketched by you) to illustrate concepts
- References to previously learned concepts

[file i04498](#)

---

### Question 25

Read and outline the “AC Motor Braking” section of the “Variable-Speed Motor Controls” chapter in your *Lessons In Industrial Instrumentation* textbook.

The purpose of your outline is to foster close reading of the text, to facilitate quick referencing of specific points within the text, to record questions of your own, and to practice clear writing. Your outline must meet the following standards for full credit: *every major idea contained in the text represented in your outline, entirely in your own words (i.e. no copying of text), written in a legible and comprehensible manner, of sufficient quality that others would find it informative.* Incomplete, illegible, cryptic, and/or plagiarized outlines will not receive full credit. A suggestion is one sentence of your own per paragraph of source text. Helpful additions include:

- Noting questions or points of confusion you have from the reading
- Page numbers from the source text for quick reference during discussion
- Images copied from the text (or sketched by you) to illustrate concepts
- References to previously learned concepts

[file i04761](#)

---

### Question 26

Read and outline the “Use of Line Reactors” section of the “Variable-Speed Motor Controls” chapter in your *Lessons In Industrial Instrumentation* textbook.

The purpose of your outline is to foster close reading of the text, to facilitate quick referencing of specific points within the text, to record questions of your own, and to practice clear writing. Your outline must meet the following standards for full credit: *every major idea contained in the text represented in your outline, entirely in your own words (i.e. no copying of text), written in a legible and comprehensible manner, of sufficient quality that others would find it informative.* Incomplete, illegible, cryptic, and/or plagiarized outlines will not receive full credit. A suggestion is one sentence of your own per paragraph of source text. Helpful additions include:

- Noting questions or points of confusion you have from the reading
- Page numbers from the source text for quick reference during discussion
- Images copied from the text (or sketched by you) to illustrate concepts
- References to previously learned concepts

[file i03841](#)

## Question 27

A *Variable Frequency Drive* or *VFD* is an electronic power controller designed to exert control over the operation of a three-phase AC induction motor. VFDs are extremely versatile devices, able to control the motor's speed and direction via command signals sent to it by external devices such as switches, potentiometers, loop controllers, and even computers. A typical VFD-controlled motor appears in this illustration:

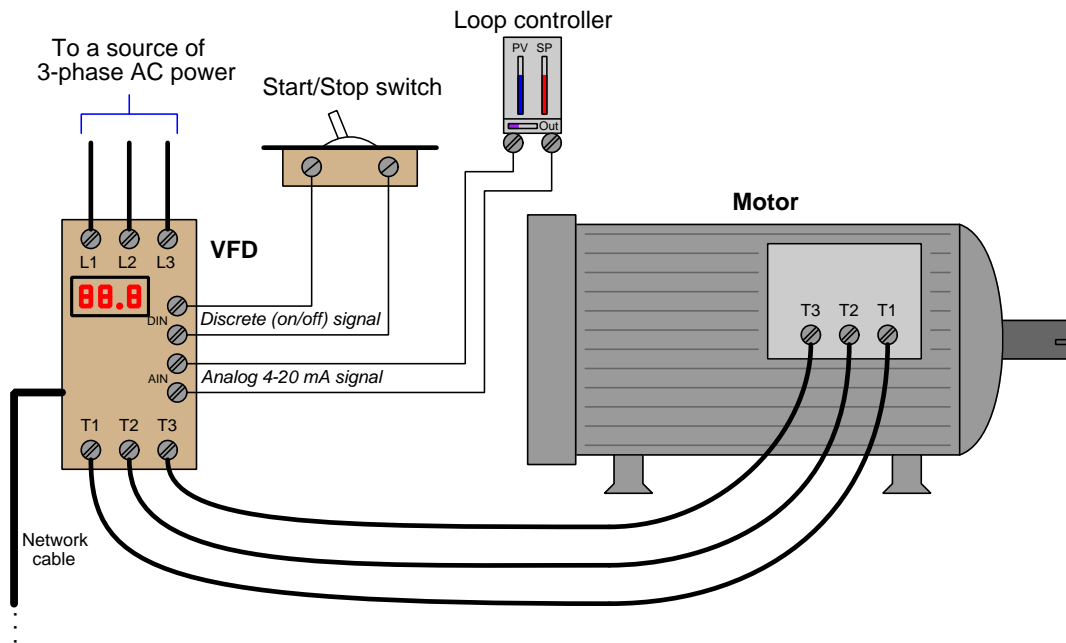

The VFD takes AC input power, rectified it into DC, then converts it into three-phase AC at a frequency matching the desired motor speed. In addition to varying the frequency of the power sent to the motor, the VFD also adjusts the output voltage in order to create the desired amount of torque (i.e. twisting force) at the motor shaft.

In this system, a discrete (on/off) signal from a SPST switch commands the VFD to start and stop the motor, while an analog 4-20 mA current signal commands the motor's speed. A network cable allows other data to be written or read by a computer, PLC, or other digital control device. The ability to externally control a VFD makes it very useful as a final control element in an automation system.

Being programmable devices, VFDs typically have dozens if not hundreds of user-configurable *parameters* defining such important factors as the motor's nameplate ratings, acceleration and deceleration time limits, maximum speed, braking methods, etc. Arguably the most important VFD parameters are those associated with the electric motor's ratings. Improper setting of these VFD parameters may result in premature motor failure and/or destruction of the VFD!

Suppose you were tasked with programming a VFD's parameters to match it to a large electric motor turning a water pump at a wastewater treatment plant. This motor will be started and stopped by a computer digitally communicating with the VFD via a Modbus network, with motor speed set by a 4-20 mA analog signal (with 4 mA being completely stopped and 20 mA being full-speed). Assume we wish to limit the motor's speed to a maximum of 500 RPM. The pump motor's nameplate is shown in the following photograph:

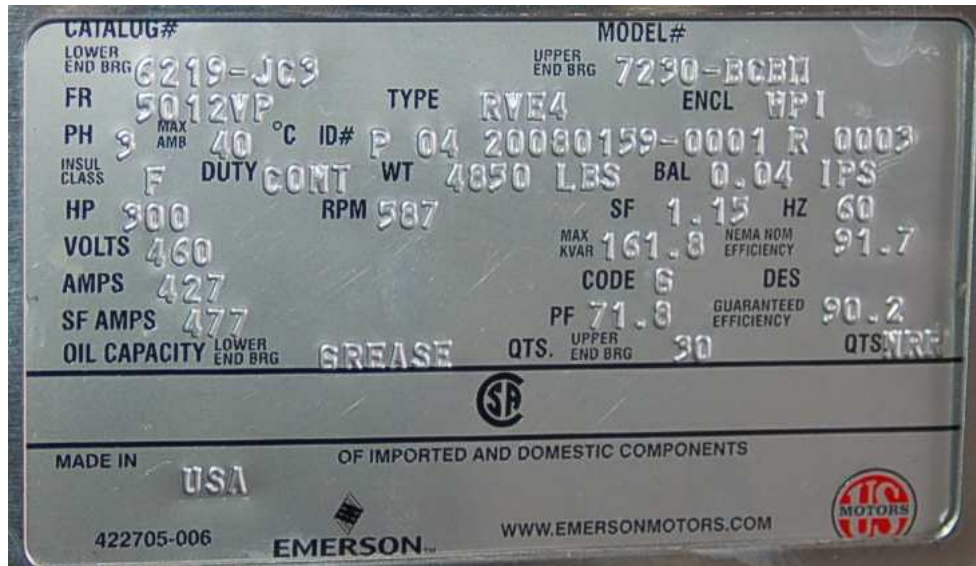

Some of the VFD's many parameters are listed below. For each one, provide either a numerical value or "N/A" (not applicable, if you cannot determine) based solely on the data you have about this motor:

- Parameter 01 (Acceleration Time) = \_\_\_\_\_ seconds
- Parameter 02 (Deceleration Time) = \_\_\_\_\_ seconds
- Parameter 03 (Volts/Hz Curve) = \_\_\_\_\_ 0 (*Default*), 1 (*High Torque*), or 2 (*Fans/Pumps*)
- Parameter 04 (DC Boost) = \_\_\_\_\_ Percent
- Parameter 05 (Overload Current) = \_\_\_\_\_ Amperes
- Parameter 06 (Line Voltage) = \_\_\_\_\_ Volts
- Parameter 07 (Base Frequency) = \_\_\_\_\_ Hz
- Parameter 08 (Base Speed) = \_\_\_\_\_ RPM
- Parameter 09 (Speed Reference) = \_\_\_\_\_ 0 (*Keypad*), 1 (*4-20 mA*), 2 (*Modbus*), or 3 (*Fixed*)
- Parameter 10 (Start Source) = \_\_\_\_\_ 0 (*Keypad*), 1 (*2-wire switch*), 3 (*3-wire switch*), or 4 (*Modbus*)
- Parameter 11 (Minimum Output Frequency) = \_\_\_\_\_ Hz
- Parameter 12 (Maximum Output Frequency) = \_\_\_\_\_ Hz

file i01389

## Question 28

Enter the base motor parameters into a VFD provided to you by the instructor. The VFD may be pre-wired to a power source and motor for you, or you may have to land those wire connections yourself.

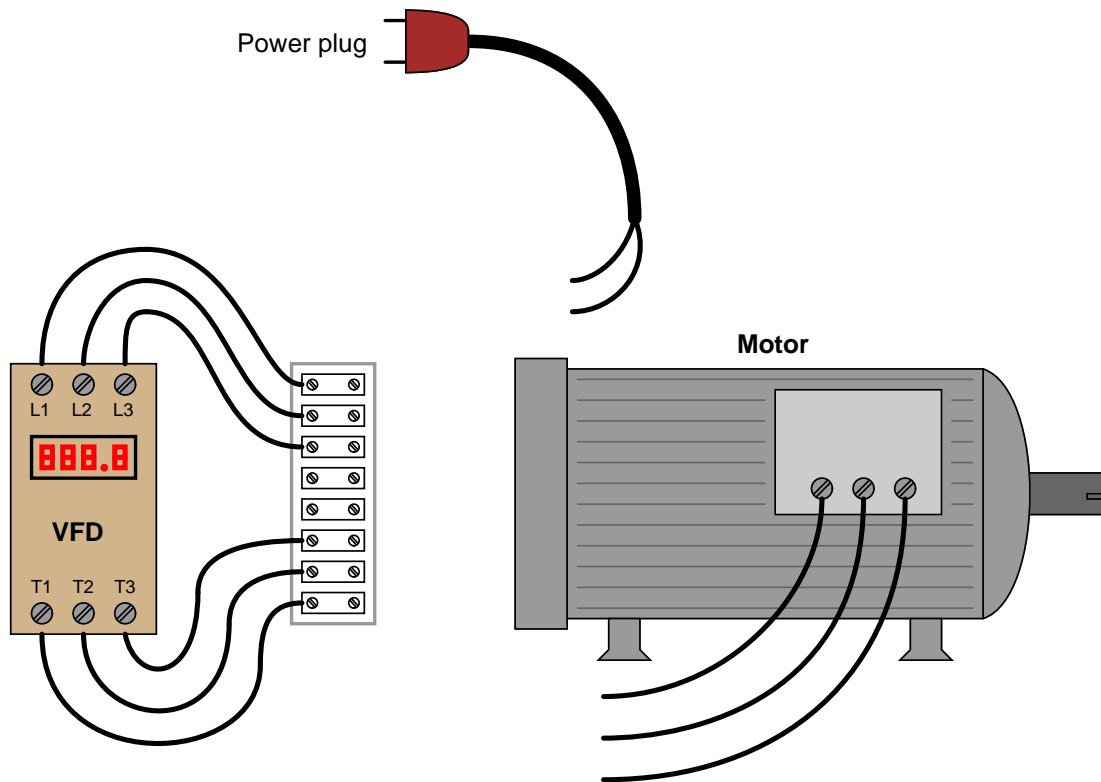

Configure the following parameters in the VFD:

- **“Base” parameters** (voltage, frequency, maximum speed, etc.): *these values are found on the motor’s nameplate, and should always be set first in the VFD before setting any other parameters! Failure to properly configure the VFD’s “base” parameters with the motor’s nameplate data may result in motor damage!*
- **Acceleration and deceleration times.** *Note that you should not set these parameters for unreasonably short times (5 seconds is a good “minimum” value), or else you may damage the motor and/or the VFD!*

After this, you may try running the motor. The VFD should provide pushbutton or knob control of the motor’s speed, as well as Start and Stop functions.

### Suggestions for Socratic discussion

- Describe by way of illustration what may happen if the “base” parameters within a VFD are set incorrectly, being as specific as possible.
- Some large VFDs need to be “gently” powered up if they have been left un-powered for long periods of time, to avoid “shocking” the capacitors used to filter their DC busses. Identify a means of doing so (i.e. limiting the inrush current that will occur when fully discharged capacitors are connected to a voltage source) that is easy and safe to implement.

- How should one set the acceleration and deceleration times if the goal is to absolutely minimize inrush current?
- Explain why a deceleration time that is too short may result in a VFD *DC bus overvoltage* condition.
- How do the acceleration and deceleration features of the VFD duplicate the function of a *soft-start* unit?

[file i04295](#)

---

#### Question 29

Use a clamp-on ammeter to measure line current to the VFD, and/or from the VFD (to the motor). Compare the measurement given by the ammeter when it is clamped around a single conductor, versus when it is clamped around multiple conductors. Does it register differently? Why or why not?

Another interesting experiment is to loop a single current-carrying conductor around the ammeter's jaws so that it passes through the center of the clamp more than once. What effect does this arrangement have on the ammeter's reading, and why?

#### **Suggestions for Socratic discussion**

- Identify a practical application for passing all power conductors feeding a VFD through the center of a single current transformer (CT). What, exactly, would that CT's output signal represent?

[file i03860](#)

### Question 30

Connect a toggle switch to the VFD in such a way that the switch status controls the starting and stopping of the motor, rather than starting and stopping the motor from the VFD's front-panel controls. You will need to research the VFD's User Manual both for determining where to connect the switch as well as which parameter to change to make the VFD responsive to this external switch input.

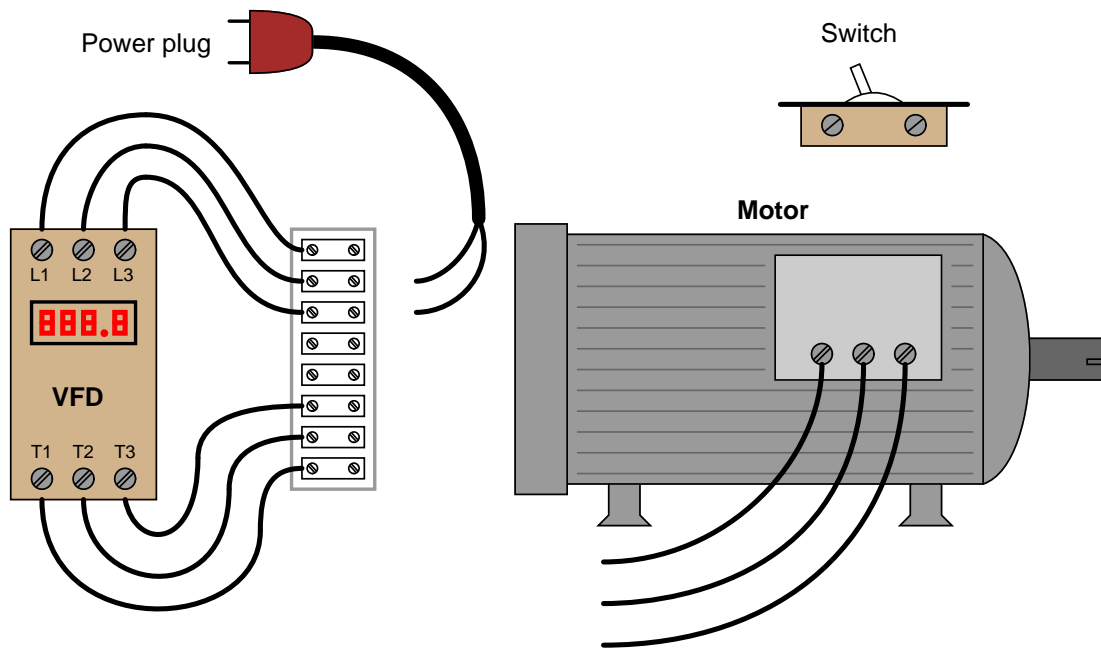

As always, your wire connections should be marshalled through terminal blocks (no taped or twisted wire joints!), with no bare copper showing at the connection points.

#### Suggestions for Socratic discussion

- Describe what the “base” parameters in a VFD refer to, and explain why these parameters are among the most important settings in the VFD. Describe by way of illustration what may happen if these base parameters are set incorrectly.
- Some large VFDs need to be “gently” powered up if they have been left un-powered for long periods of time, to avoid “shocking” the capacitors used to filter their DC busses. Identify a means of doing so (i.e. limiting the inrush current that will occur when fully discharged capacitors are connected to a voltage source) that is easy and safe to implement.
- Identify a practical application for a remote start/stop switch such as this.

[file i04075](#)



### Question 31

Connect a potentiometer to the VFD in such a way that the pot's position controls the speed of the motor, rather than a knob or buttons on the VFD's front-panel. You will need to research the VFD's User Manual both for determining where to connect the potentiometer as well as which parameter to change to make the VFD responsive to this external pot setting.

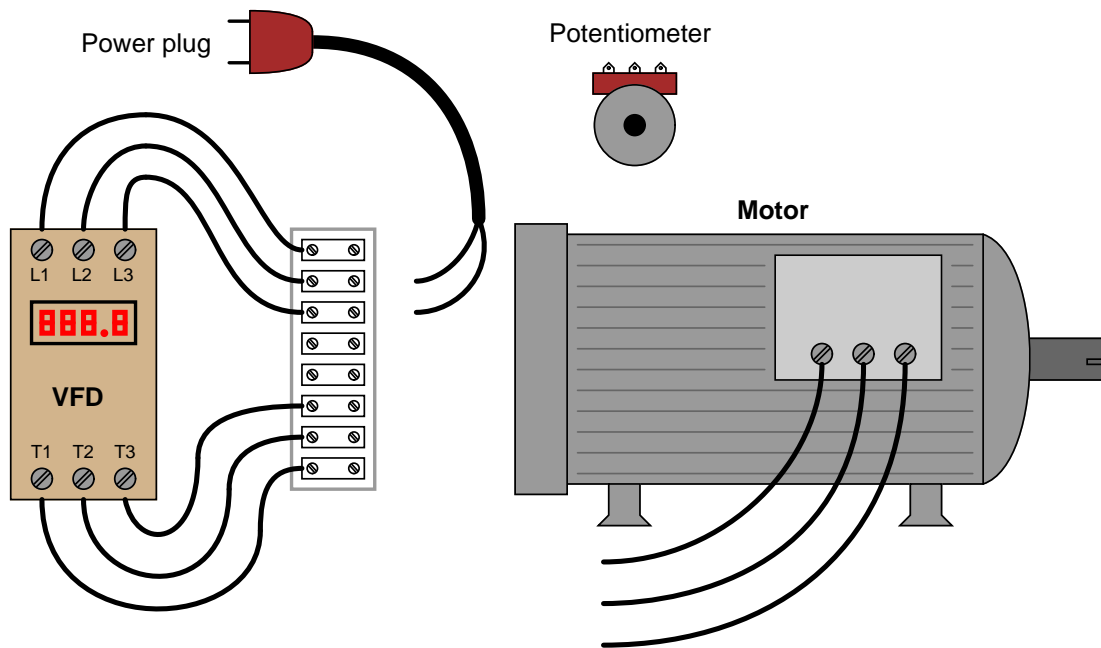

As always, your wire connections should be marshalled through terminal blocks (no taped or twisted wire joints!), with no bare copper showing at the connection points.

#### Suggestions for Socratic discussion

- Describe what the “base” parameters in a VFD refer to, and explain why these parameters are among the most important settings in the VFD. Describe by way of illustration what may happen if these base parameters are set incorrectly.
- Some large VFDs need to be “gently” powered up if they have been left un-powered for long periods of time, to avoid “shocking” the capacitors used to filter their DC busses. Identify a means of doing so (i.e. limiting the inrush current that will occur when fully discharged capacitors are connected to a voltage source) that is easy and safe to implement.
- Identify a practical application for a remote speed control such as this.

[file i04074](#)

Question 32

*Synchronous AC* motors by their nature rotate at precisely the same speed as the rotating magnetic field produced by the stator windings. The practical problem with this is how to get a synchronous motor started, since it is physically impossible for the rotor to jump from a stand-still to 100% speed in zero time.

Therefore, synchronous motors are usually started as regular induction motors at first, and then they are switched to synchronous mode when their speed is very near 100%. The following control circuit shows one scheme for this dual-mode start-up. The rotor on this synchronous motor has its own winding:

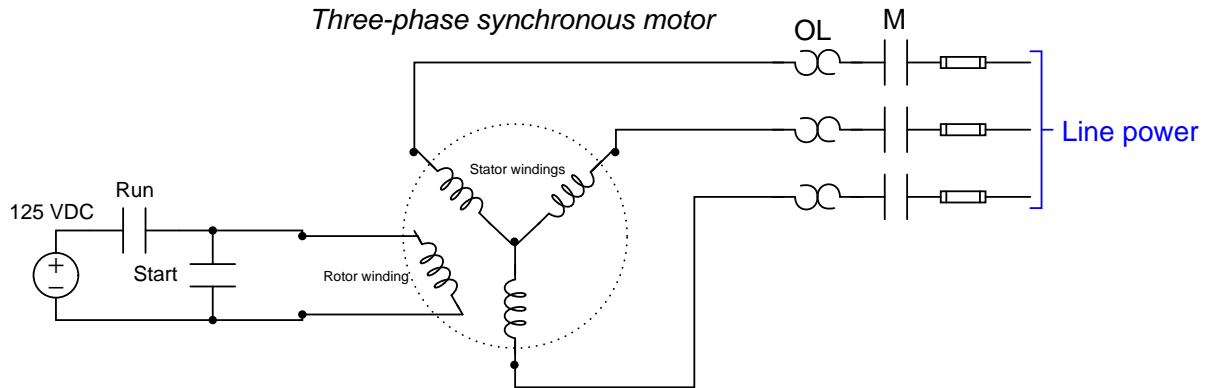

Control circuit wiring

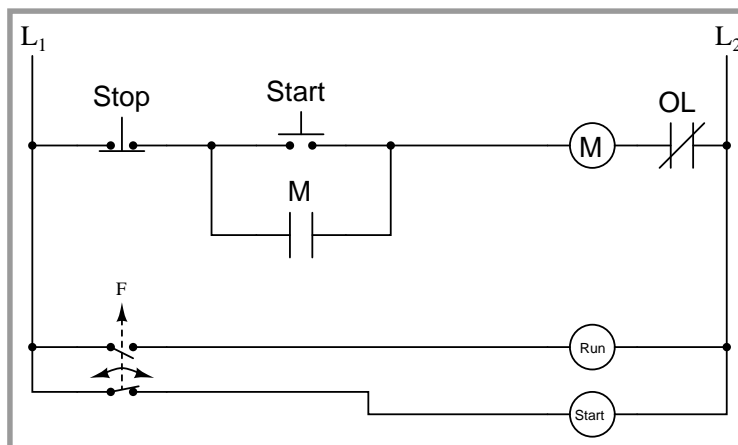

Explain how this start-up circuit functions, and what goes on with the switching of the rotor winding to make the motor start up and then run in two different modes.

**Suggestions for Socratic discussion**

- What practical applications might warrant the use of a synchronous AC motor instead of an induction AC motor?

[file i03758](#)

Question 33

Determine the directions of electric current where you see question marks in the following schematic diagram for a variable-speed AC motor drive, at the moment in time ( $t_1$ ) specific on the oscillograph:

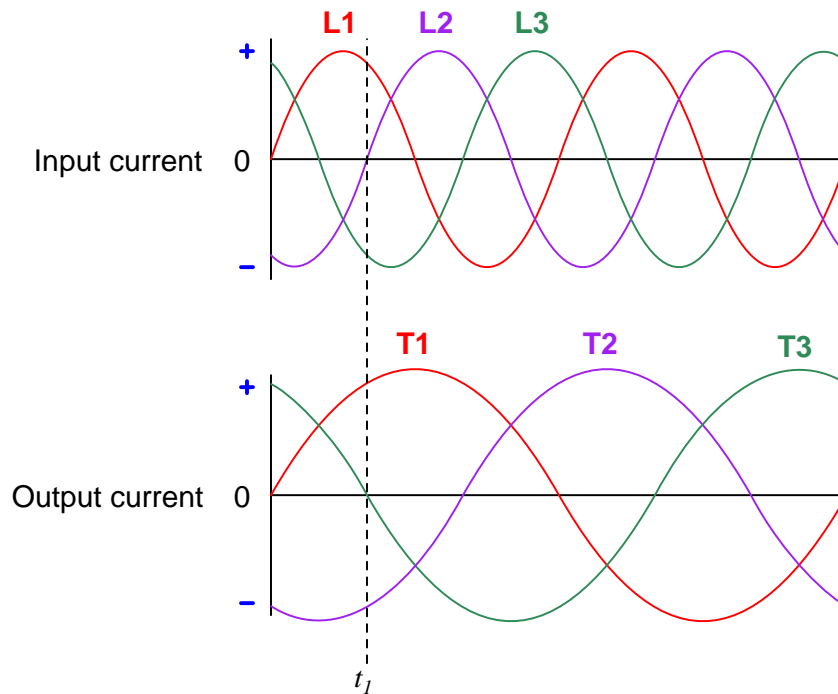
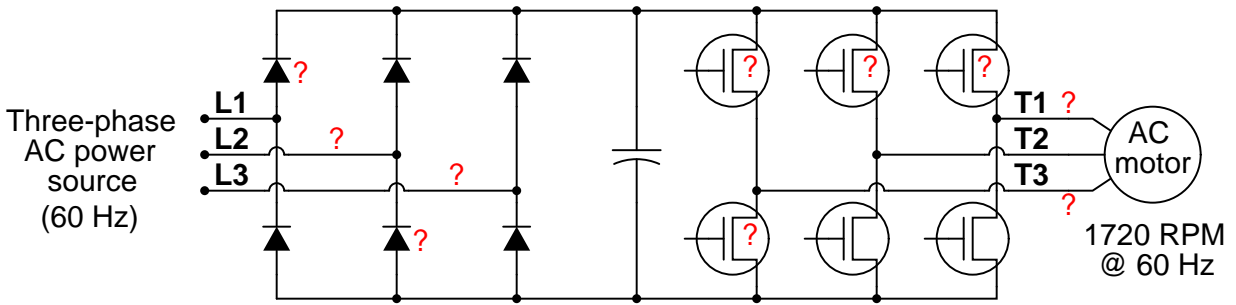

Use conventional flow notation to show current direction (a “positive” current flowing from power source to motor, and a “negative” current flowing from motor to power source). If there is no current going through a labeled wire or component, just write **NO** instead of drawing an arrow on the diagram.

Also, estimate the speed of the electric motor based on the waveforms shown in the oscillographs.  
[file i01715](#)

Question 34

A *single-phase bridge rectifier* circuit is made of four diodes, arranged like this:

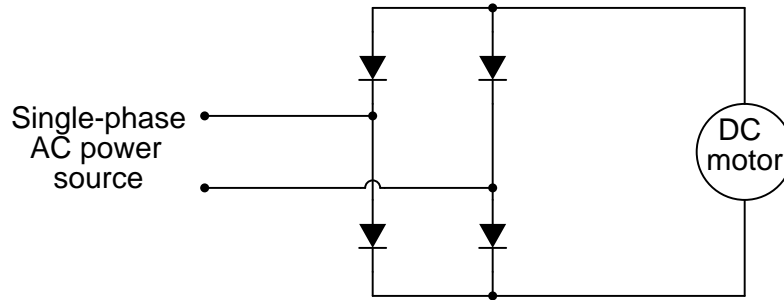

Trace the directions of current through all four diodes, and determine the polarity of DC voltage across the motor terminals.

A *three-phase bridge rectifier* circuit is made of six diodes, arranged like this:

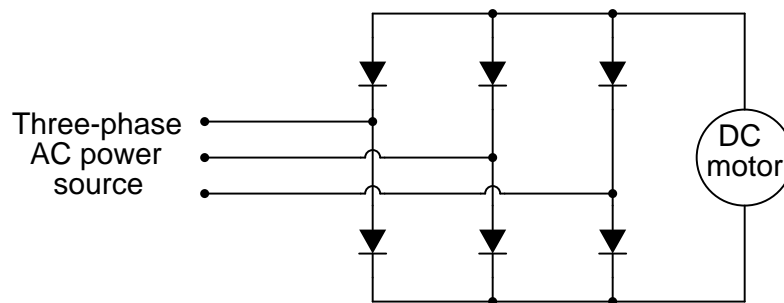

Once again, trace the directions of current through all six diodes, and determine the polarity of DC voltage across the motor terminals.

[file i01437](#)

---

Question 35

Connect an oscilloscope in parallel with the VFD's power line connections (through a step-down transformer) to monitor the input voltage waveform while the drive is running and while it is stopped. What effect do you notice on the sine wave's shape when the drive is active?

Try sketching each waveshape (drive running vs. not running) here:

Line voltage waveform (VFD stopped)

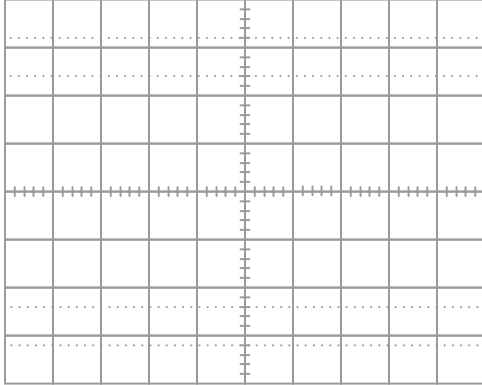

Line voltage waveform (VFD running)

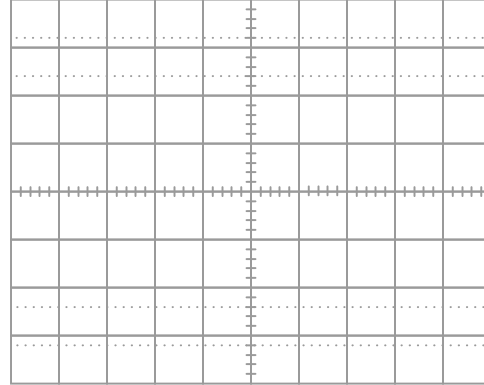

Another experiment to try is operating an AM radio near a VFD when it is stopped versus when it is running. Explain why the radio responds as it does to the VFD's status.

**Suggestions for Socratic discussion**

- How might the harmonics generated by a VFD interfere with nearby electronic equipment?
- How can a technician detect the presence of harmonics, and more importantly locate the precise source of harmonic distortion in a power system?
- How is it possible to “shield” other equipment on the power system from harmonics generated by a particular VFD?

[file i04065](#)

---

Question 36

Experiment with different V/Hz (volts per hertz) profile settings for a VFD controlling the speed of an induction AC motor. Then, operate the motor at different frequencies while measuring line voltage to the motor (between terminals T1-T2, T2-T3, or T1-T3) using a true-RMS AC voltmeter. Calculate the actual V/Hz ratio at each speed by taking the measured voltage and dividing by the frequency.

**General Purpose setting**

Frequency	Voltage (V RMS)	V/Hz (calculated)
10 Hz		
20 Hz		
30 Hz		
40 Hz		
50 Hz		
60 Hz		

**High Starting Torque setting**

Frequency	Voltage (V RMS)	V/Hz (calculated)
10 Hz		
20 Hz		
30 Hz		
40 Hz		
50 Hz		
60 Hz		

Explain in your own words how the VFD achieves a greater starting torque by modifying the V/Hz ratio in the “high starting torque” setting.

[file i04083](#)

Question 37

An AC electric power system has a bank of capacitors connected to correct for low power factor. One day a new VFD is installed to provide variable-speed control for an existing AC motor. The VFD has its own line reactors connected on the input side to help filter harmonics from the rest of the AC power system. The problem is, the line reactors and the power factor correction capacitors now form a *resonant circuit* that may produce high currents and/or voltages at a certain frequency:

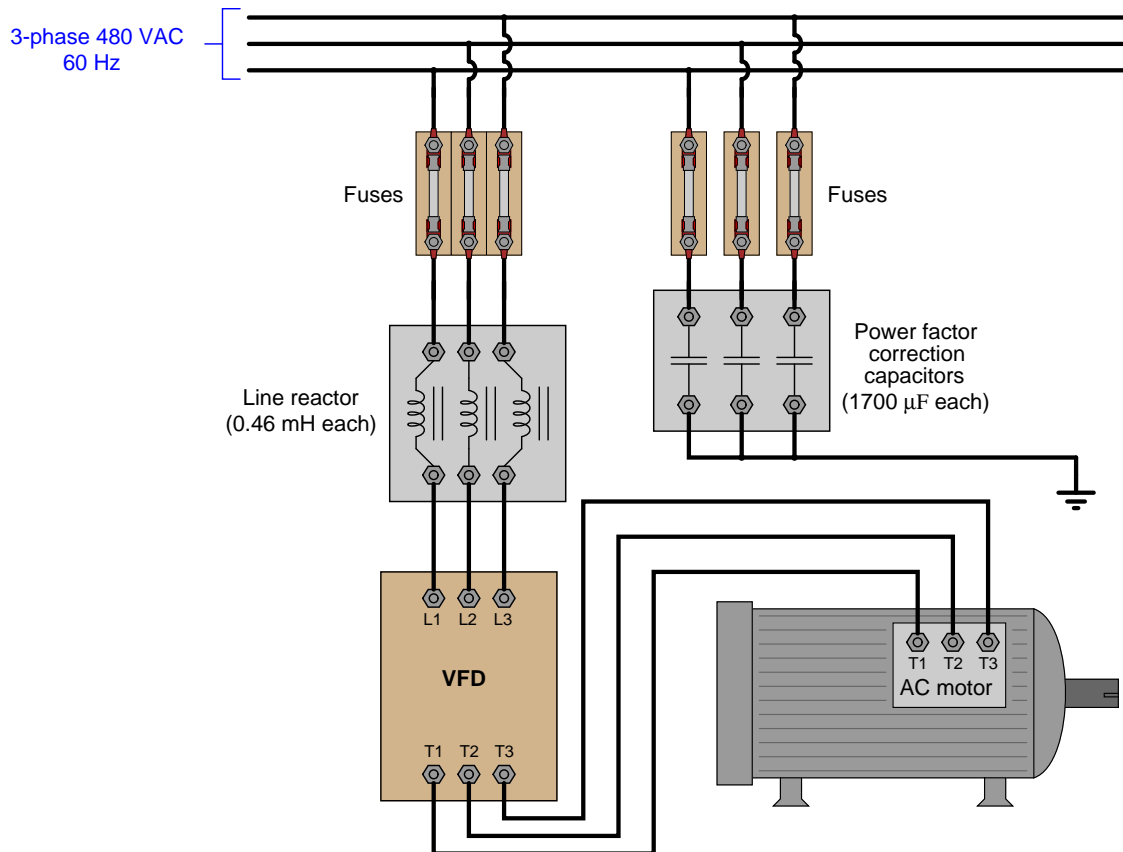

Calculate the resonant frequency of the circuit formed by the reactor coils and power factor correction capacitors, then determine whether or not resonance will be a problem in this system. Explain why or why not, showing all your mathematical work. Note: for the sake of simplicity, you may model each resonant circuit as simple pairs of one reactor coil and one capacitor in series with each other.

[file i03133](#)

---

### Question 38

Suppose a large grinding machine used in a production machine shop is powered by an induction motor, which in turn receives its electrical power from a VFD. The time for this machine to coast to a stop after running at full speed is quite long, owing to the mass of the spinning grinding wheel. This “coast” time has a negative effect on production, because the operators must wait until the wheel finally stops before they can take the freshly-ground parts off the machine and replace them with new parts to be ground.

Your supervisor would like to shorten this “stopping” time by using the *dynamic braking* feature of the VFD, which up to this point in time had never been configured for use. Explain where the stored (kinetic) energy of the spinning grinding wheel goes when the VFD dynamically brakes it to a quick stop.

#### **Suggestions for Socratic discussion**

- What are some alternative braking techniques to dynamic braking? In each of these techniques, where does the grinding wheel’s kinetic energy go during the braking process?

[file i03843](#)



Question 39

This “lift station” pump control circuit has a problem. The sump pump is supposed to come on when the high level is reached, and turn off when the water pumps down to the low level point. Instead, however, the motor “cycles” on and off at the high-level point.

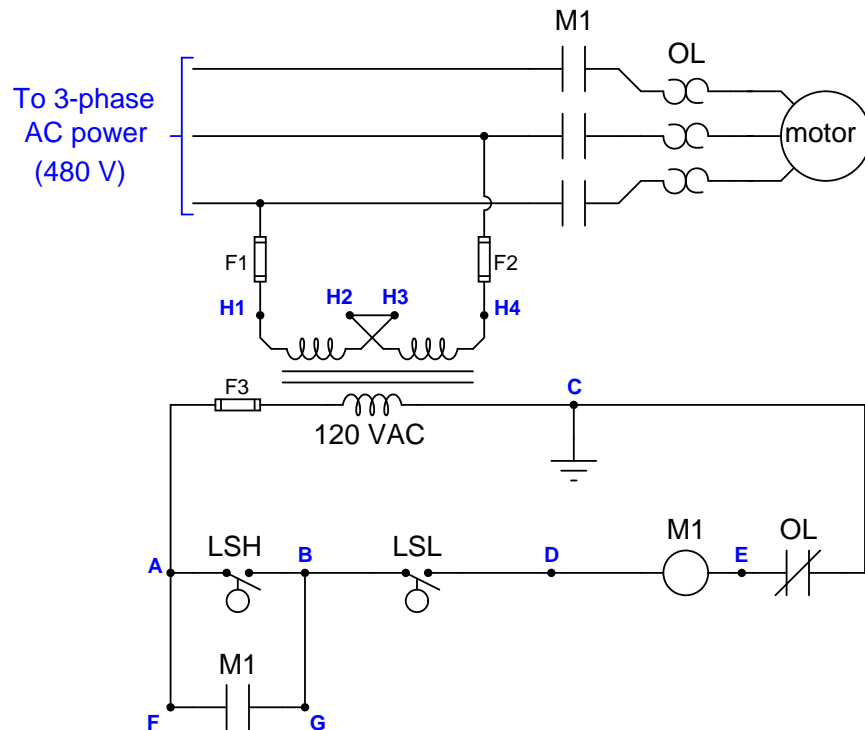

Using an AC voltmeter, you measure a voltage from point **D** to point **E** that switches back and forth between 120 volts and 0 volts.

Identify the likelihood of each specified fault for this circuit. Consider each fault one at a time (i.e. no coincidental faults), determining whether or not each fault could independently account for *all* measurements and symptoms in this circuit.

Fault	Possible	Impossible
High level switch failed open		
Low level switch failed open		
Broken wire between <b>D</b> and M1 coil		
Contactor auxiliary contact failed open		
480 volt fuse(s) blown		
Contactor main contact(s) failed open		
Broken wire between <b>B</b> and <b>G</b>		
Thermal overload unit tripped		
Low level switch failed shorted		
Transformer secondary winding failed open		

Finally, identify the *next* diagnostic test or measurement you would make on this system. Explain how the result(s) of this next test or measurement help further identify the location and/or nature of the fault.  
[file i03844](#)

Question 40

This variable-frequency motor drive (VFD) circuit converts three-phase AC power at 60 Hz into rectified and filtered DC, then switches that DC into three-phase AC of whatever frequency desired. The control circuitry for triggering the MOSFETs is not shown in this diagram, for the sake of simplicity:

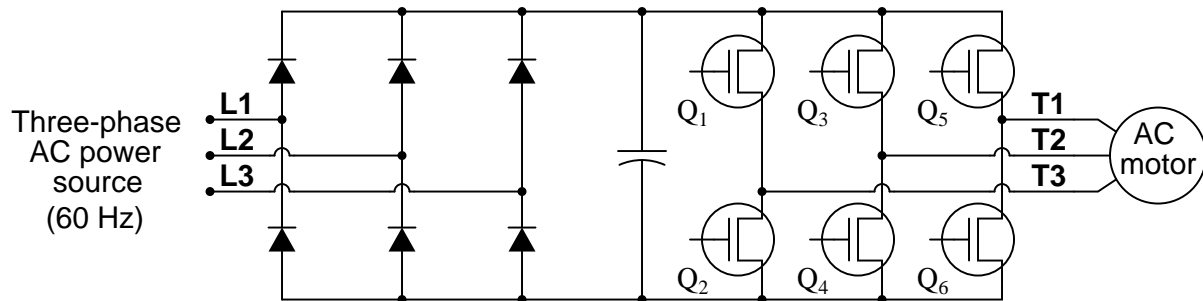

Your task is to determine the states (ON or OFF) of those six transistors during each of the time periods shown in the oscillograph:

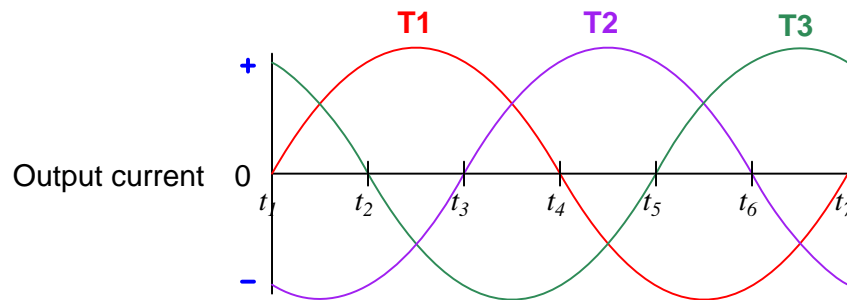

Time period	$Q_1$	$Q_2$	$Q_3$	$Q_4$	$Q_5$	$Q_6$
$t_1 - t_2$						
$t_2 - t_3$						
$t_3 - t_4$						
$t_4 - t_5$						
$t_5 - t_6$						
$t_6 - t_7$						

Assume a “positive” current on the graph is one where the drive *sources* current to the motor, and a “negative” current on the graph is one where the drive *sinks* current from the motor.

**Suggestions for Socratic discussion**

- What would be different, if anything, about the switching of these six power transistors to make the motor spin *faster*?
- What would be different, if anything, about the switching of these six power transistors to make the motor spin in *reverse* rather than forward?

[file i01723](#)

---

## Question 41

Identify any general principles applicable to the topics within this course, and describe where you applied some of these principles. Examples include:

- Conservation of Energy
- Conservation of Mass
- Negative feedback
- Electrical principles:
- Unit conversion and dimensional analysis
  - Kirchhoff's Voltage Law (KVL) and Kirchhoff's Current Law (KCL)
  - Ohm's Law
  - Properties of series and parallel networks
  - Capacitance and Inductance
  - Transformers
  - Filtering networks
  - Semiconductor switching

Next, identify any problem-solving strategies applicable to the problems you faced in this course, and describe where you applied them. Examples include:

- Performing “thought experiments”
- Re-drawing a complex diagram in simpler form
- Annotating a diagram to show relevant quantities
- Simplifying the problem, and solving that simpler version first
- Collecting data and analyzing for patterns

### **Suggestions for Socratic discussion**

- One useful strategy is to maintain a *journal* of all you've learned in a course of study. Explore ways you could take the work you're already doing to prepare for homework (daily discussions with your instructor) and turn this into a journal or even a weblog (“blog”) for your own reflection and eventual use as a portfolio to showcase your capabilities to employers.
- Where exactly are the practice problem worksheets located on the *Socratic Instrumentation* website?
- Peruse the “feedback questions” for this (and/or past) course sections to identify any questions related to areas you would like to strengthen.

[file i00999](#)

## Question 42

Examine this control circuit diagram for an air compressor, where a pair of pressure switches controls the starting and stopping of the electric motor turning the air compressor:

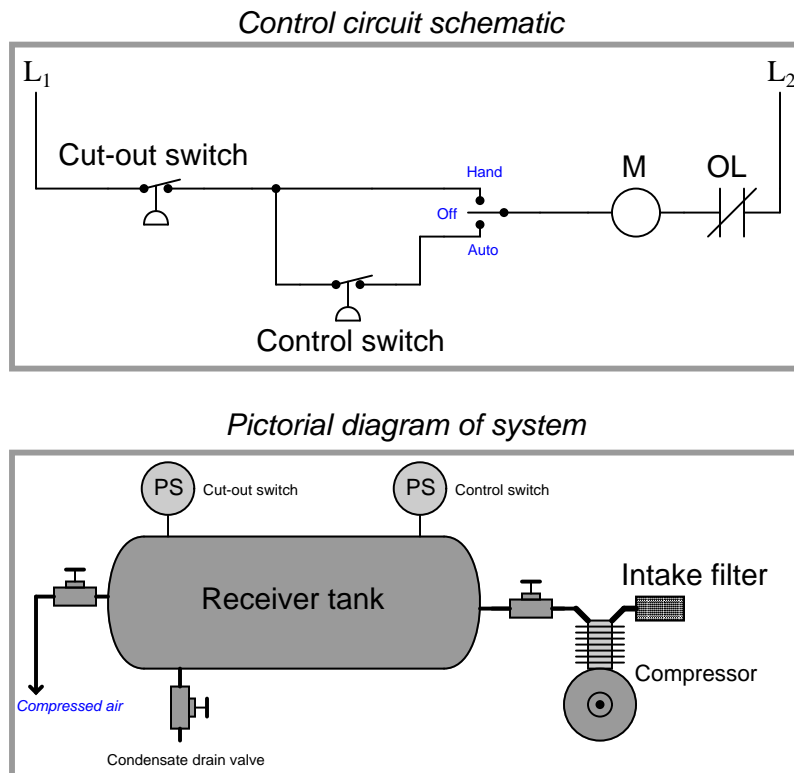

Explain what the “Hand-Off-Auto” switch does in this circuit, and also describe the functions of each pressure switch.

Also, add a high-temperature shutdown switch to this circuit, the purpose being to prevent the compressor from running if ever overheats (regardless of pressure status or Hand-Off-Auto mode).

### Suggestions for Socratic discussion

- Which of these two pressure switches should have the greater trip setting, and why?
- Why do you think operations personnel might find it useful to have a “Hand” position as well as an “Auto” position on the switch in this air compressor system?
- Some “Hand-Off-Auto” switches place the “Auto” position in the middle, between the “Hand” and the “Off” settings – explain why this might be a better way to arrange the three-position switch.
- Identify the consequences of jumpering across the OL switch contacts in this circuit using a piece of wire.
- Identify the consequences of jumpering across the Cut-out pressure switch contacts in this circuit using a piece of wire.
- Identify the consequences of jumpering across the “M” contactor coil in this circuit using a piece of wire.
- Identify the consequences of jumpering across the Control pressure switch contacts in this circuit using a piece of wire.
- Identify the consequences of jumpering across the “M” contactor coil in this circuit using a piece of wire.

- Identify the consequences of jumpering between the “Hand” and “Auto” terminals on the manual selector switch using a piece of wire.

[file i04056](#)

#### Question 43

Examine this motor control circuit, designed to bring the motor to a quick halt whenever the “Stop” button is pressed. The system uses two motor contactors (“F” and “R”), each one wired to power the motor in a different direction (forward versus reverse):

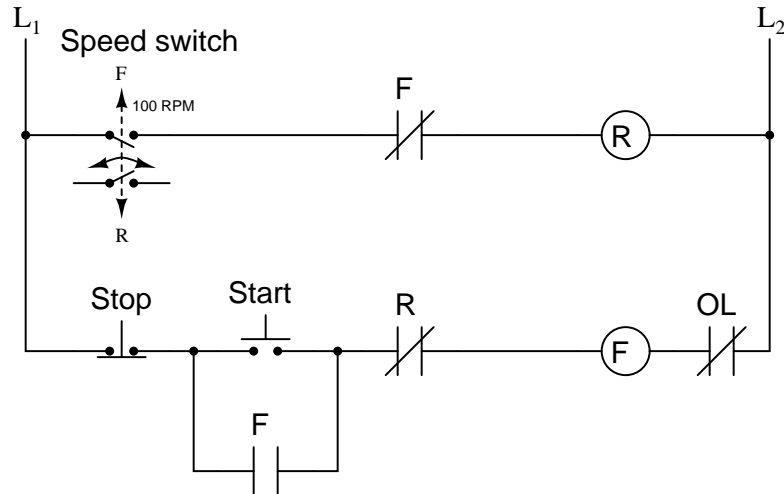

Explain how this automatic braking system works.

#### Suggestions for Socratic discussion

- Does this braking strategy remind you of one sometimes implemented in VFDs?
- Can you think of any disadvantages to this braking scheme?
- Modify the schematic diagram to contain a hand switch that disables the braking feature.
- Identify any potentially dangerous failure modes in this circuit (i.e. ways in which a component might fail that would make the motor run in a dangerous way).
- Why doesn't the reverse contactor coil (“R”) have OL contacts connected in series like the forward contactor coil (“F”)?
- Identify the consequences of jumpering across the “R” contactor coil in this circuit using a piece of wire.
- Identify the consequences of jumpering across the “F” contactor coil in this circuit using a piece of wire.
- Identify the consequences of jumpering across the normally-closed “F” relay contacts in this circuit using a piece of wire.
- Identify the consequences of jumpering across the normally-open “F” relay contacts in this circuit using a piece of wire.
- Identify the consequences of jumpering across the speed switch contacts in this circuit using a piece of wire.

[file i03983](#)

Question 44

Assuming all three alternators are equally sharing the load in this power system, that the primary:secondary turns ratio in the three-phase transformer is 30:1, that the power factor is 1 throughout the system, and that all disconnect switches are closed, calculate the following:

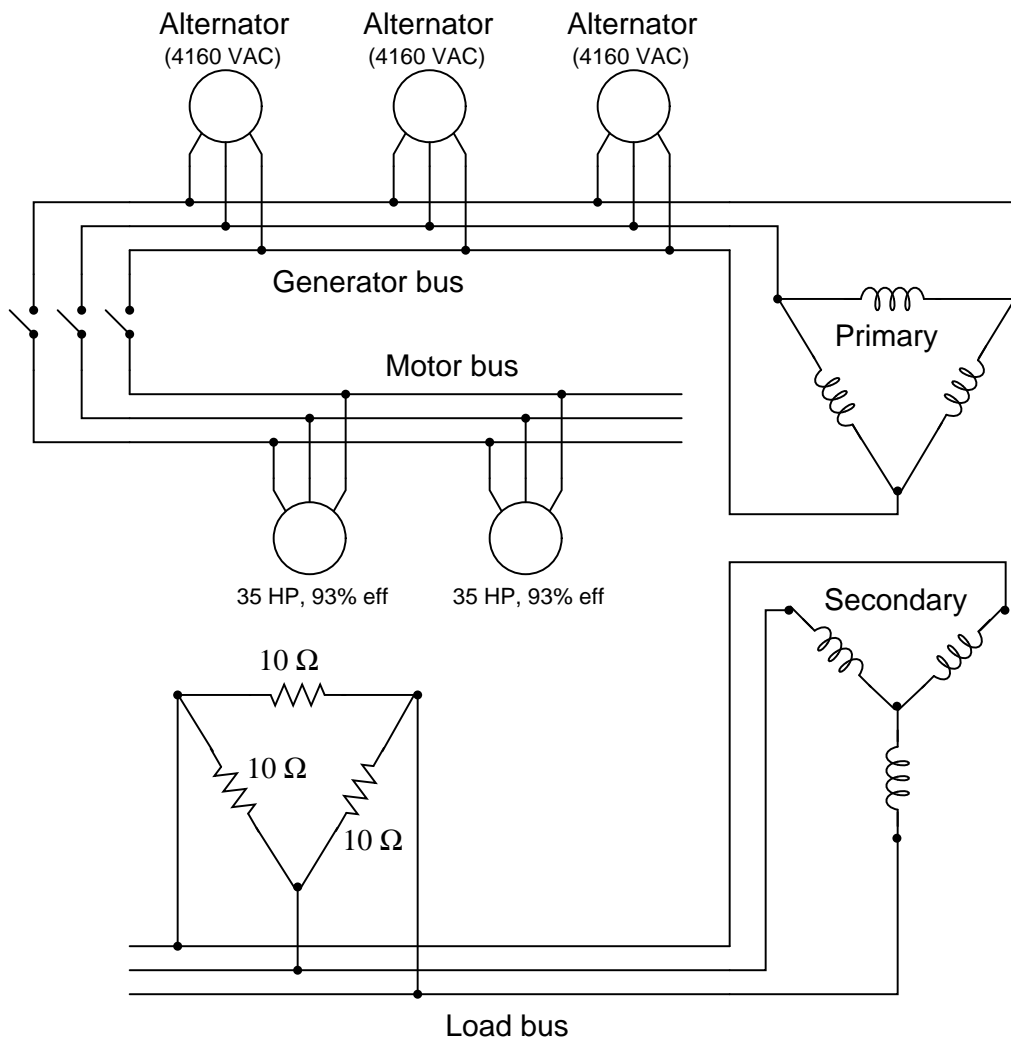

- Line voltage of the generator bus = \_\_\_\_\_ volts
- Line voltage of the load bus = \_\_\_\_\_ volts
- Line current at each alternator = \_\_\_\_\_ amps
- Total power transferred in this system with all loads running = \_\_\_\_\_ kilowatts

**Suggestions for Socratic discussion**

- Identify two currents in this circuit that are guaranteed to be equal in value, and explain why this is so.
- Identify two currents in this circuit that are unequal in value, and explain why one of them is larger than the other.

- Identify two voltages in this circuit that are guaranteed to be equal in value, and explain why this is so.
- Identify two voltages in this circuit that are unequal in value, and explain why one of them is larger than the other.

file i01046

Question 45

Examine this three-phase motor control circuit (sometimes referred to as a “bucket”), where fuses protect against overcurrent faults, a three-pole relay (called a *contactor*) turns power on and off to the motor, and a set of overload heaters detect mild overcurrent conditions. Control circuit wiring has been omitted for simplicity’s sake. Only the power wiring is shown:

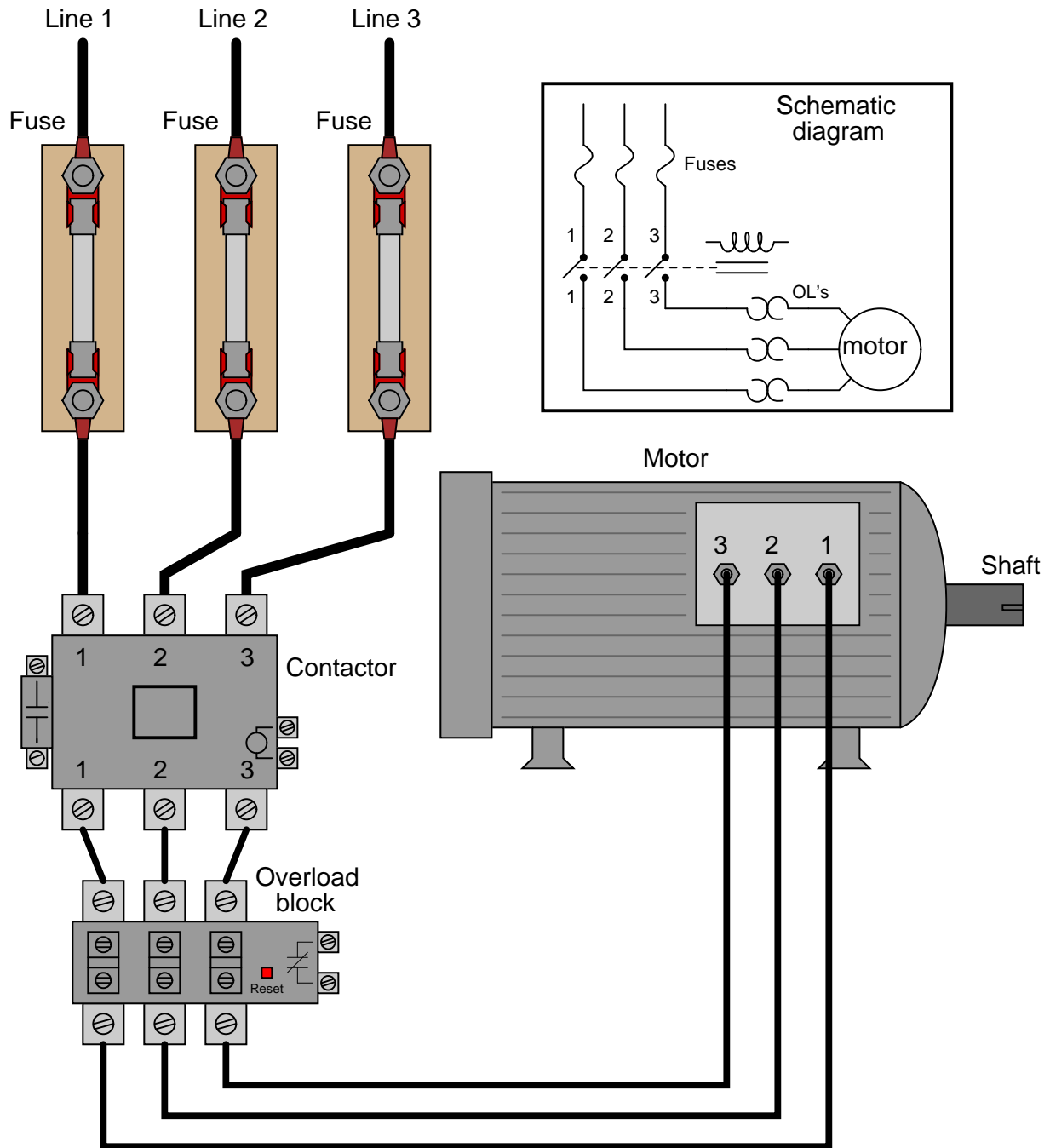

After years of faithful service, one day this motor refuses to start. It makes a “humming” sound when the contactor is energized (relay contacts close), but it does not turn. A mechanic checks it out and determines that the shaft is not seized, but is free to turn. The problem must be electrical in nature!



You are called to investigate. Using a clamp-on ammeter, you measure the current through each of the lines (immediately after each fuse) as another start is once again attempted. You then record the three current measurements:

Line	Current
1	52.7 amps
2	51.9 amps
3	0 amps

Determine at least two possible faults, either one fully capable of causing the motor's refusal to start and the three current measurements taken. Then, decide what your next measurement(s) will be to isolate the exact location and nature of the fault.

**Suggestions for Socratic discussion**

- Is there a way we could have determined a lack of current in line 3 without the use of a clamp-on ammeter, using a multimeter incapable of directly measuring current over 10 amps?

[file i01445](#)

---

Question 46

An instrument technician finds a great deal on a lathe for his home machine shop. The only problem is, this lathe has a three-phase motor and his shop only has single-phase electric power. This technician knows, however, that you can wire most VFDs to input single-phase AC power and output three-phase AC power, so he buys a used VFD and wires it up in this manner to power his lathe.

Not only does this "fix" allow him to run his lathe on single-phase power, but it also gives him the ability to vary the lathe's motor speed, and also to suddenly stop it if needed. Now, this particular VFD is an inexpensive model, and it has no braking resistor connected to it. Based on this information, identify the likely technique this VFD uses to brake the lathe motor, and identify where the lathe's kinetic energy will be dissipated.

**Suggestions for Socratic discussion**

- What are some alternative braking techniques to dynamic braking? In each of these techniques, where does the grinding wheel's kinetic energy go during the braking process?
- Explain what would happen to a VFD with dynamic braking if the braking resistor failed open.
- Explain what would happen to a VFD with dynamic braking if the braking resistor failed shorted.
- Explain what would happen to a VFD's braking ability if the circuit breaker feeding AC line power to it were to trip (open).

[file i03871](#)

### Question 47

A technician has wired a proximity switch to a relay, such that one LED lamp is supposed to come on when nothing is near the switch, and the other lamp is supposed to come on when the switch detects the presence of a metal object:

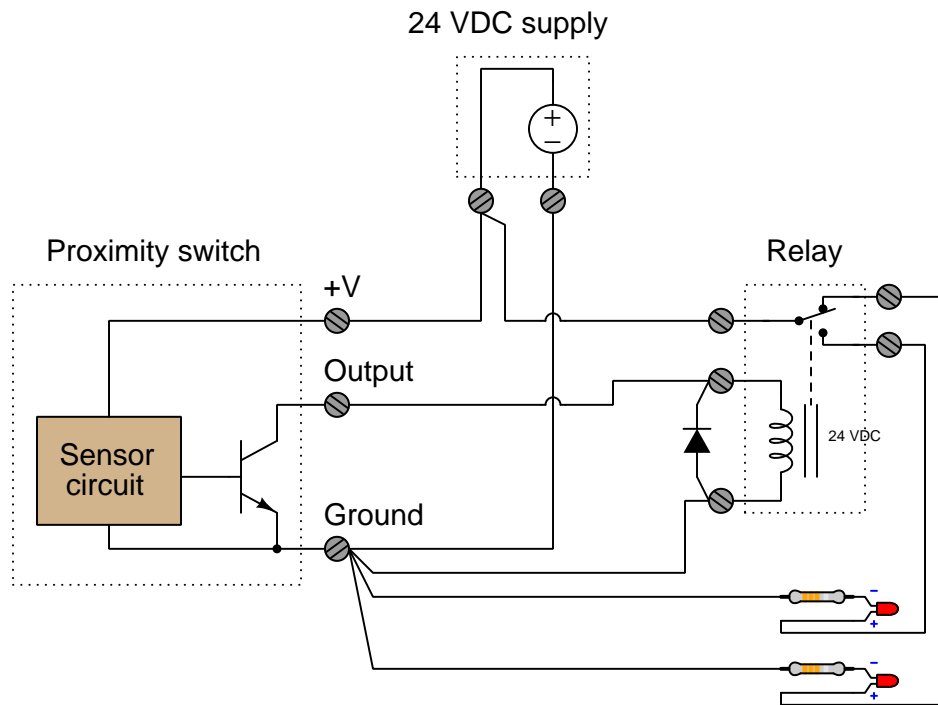

However, there is a problem in the wiring of this circuit. First, identify what this circuit will *actually* do. Next, identify the wiring problem and propose a correction so that the circuit will function as it was intended.

#### Suggestions for Socratic discussion

- Is this a *sinking* or a *sourcing* proximity switch? How can we tell?
- This is a very common wiring mistake seen in student work. Explain why many people are tempted to make this mistake, and how it may be avoided by thinking more carefully about the circuit's function.

[file i03759](#)

Question 48

This “lift station” pump control circuit has a problem. The sump pump is supposed to come on when the high level is reached, and turn off when the water pumps down to the low level point. Instead, however, the motor “cycles” on and off at the low-level point. Using an AC voltmeter, you measure a voltage from point **B** to point **D** that switches back and forth between 120 volts and 0 volts:

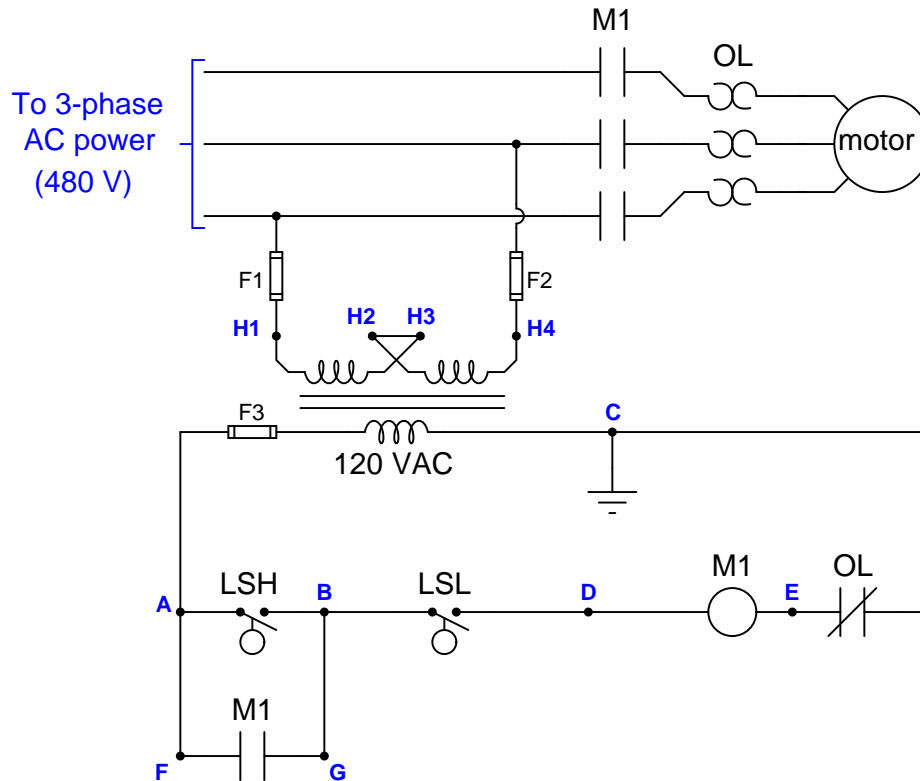

Identify the likelihood of each specified fault for this circuit. Consider each fault one at a time (i.e. no coincidental faults), determining whether or not each fault could independently account for *all* measurements and symptoms in this circuit.

Fault	Possible	Impossible
High level switch failed open		
Low level switch failed open		
Broken wire between <b>D</b> and M1 coil		
Contactor auxiliary contact failed open		
Contactor auxiliary contact failed shorted		
Contactor main contact(s) failed open		
Broken wire between <b>B</b> and <b>G</b>		
Thermal overload unit tripped		
High level switch failed shorted		
Transformer secondary winding failed open		

Finally, identify the *next* diagnostic test or measurement you would make on this system. Explain how the result(s) of this next test or measurement help further identify the location and/or nature of the fault.

file i04018

Question 49

Suppose the lamp refuses to light up. A voltmeter registers 24 volts between test points **C** and **D**:

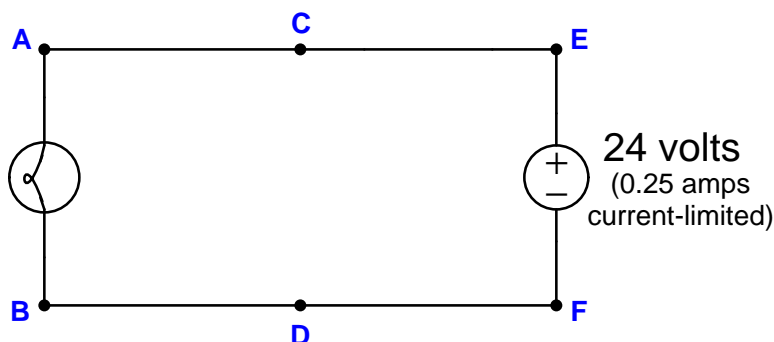

First, list all the possible (single) faults that could account for all measurements and symptoms in this circuit, including failed wires as well as failed components:

Now, determine the diagnostic value of each of the following tests, based on the faults you listed above. If a proposed test could provide new information to help you identify the location and/or nature of the one fault, mark “yes.” Otherwise, if a proposed test would not reveal anything relevant to identifying the fault (already discernible from the measurements and symptoms given so far), mark “no.”

Diagnostic test	Yes	No
Measure $V_{CF}$		
Measure $V_{ED}$		
Measure $V_{AB}$		
Measure $V_{AD}$		
Measure $V_{CB}$		
Measure $V_{EF}$		
Measure current through wire connecting <b>A</b> and <b>C</b>		
Jumper <b>A</b> and <b>C</b> together		
Jumper <b>B</b> and <b>D</b> together		
Jumper <b>A</b> and <b>B</b> together		

Finally, develop a rule you may use when assessing the value of each proposed test, based on a comprehensive list of possible faults.

**Suggestions for Socratic discussion**

- Identify which fundamental principles of electric circuits apply to each step of your analysis of this circuit. In other words, be prepared to explain the reason(s) “why” for every step of your analysis, rather than merely describing those steps.
- Suppose the fault were intermittent: sometimes the lamp lights up, and other times it goes out. Explain how you could use a digital multimeter (DMM) set to *record* voltage as a troubleshooting tool to determine where the fault is located in the circuit over a span of time too long for you to personally observe the circuit.

[file i01746](#)

---

## Question 50

The `grades_template` spreadsheet provided for you on the Y: network drive allows you to calculate your grade for any course (by entering exam scores, attendance data, etc.) as well as project to the future for courses you have not yet taken. Download the spreadsheet file (if you have not done so yet) and enter all the data you can for grade calculation at this point in the quarter.

Also, locate the pages in your course worksheet entitled “Sequence of Second-Year Instrumentation Courses” to identify which courses you will need to register for next quarter.

Lastly, prepare to comment on your job-search process to date. Where have you applied for jobs so far? Which industries most interest you, and why? Which employers have you researched, and what have you discovered so far? Which areas of the world are you interested in living and working? Which resources are you using to identify open positions (e.g. job search websites, classified advertisements, cold-calling specific employers)? Are there any places you would like to intern at in order to gain specific experience prior to employment?

If an employer were to interview you today, how would you describe your knowledge and skill set? What do you have listed on your resume that *demonstrates* (and not just claims) your work ethic and expertise?

### **Suggestions for Socratic discussion**

- If you do not yet have enough data to calculate a final grade for a course (using the spreadsheet), experiment with plugging scores into the spreadsheet to obtain the grade you would like to earn. How might this be a useful strategy for you in the future?
- Why do you suppose this spreadsheet is provided to you, rather than the instructor simply posting your grades or notifying you of your progress in the program courses?
- Identify any courses that are *elective* rather than required for your 2-year AAS degree.

[file i03794](#)

---

Question 51

Examining a squirrel-cage motor rotor, you see the aluminum bars of the “squirrel cage” assembly embedded in what appears to be a mass of iron constituting the bulk of the rotor’s mass. An electrician explains to you that the iron is necessary in the rotor for the stator’s magnetic field to act upon. “Without the iron there,” says the electrician, “the rotor wouldn’t spin.”

Explain what is incorrect about the electrician’s reasoning.

**Suggestions for Socratic discussion**

- This is a very common misconception among students and working technicians alike. Explain why so many people tend to get this concept wrong.
- One way to disprove an assertion is by demonstrating that the assertion leads to one or more logical absurdities. This technique is called *reductio ad absurdum* (“reducing to an absurdity”). Apply this technique to the disproof of the assertion that iron is necessary in the rotor of an induction motor in order for that rotor to generate a torque.
- Describe the direction(s) that induced current(s) take in the bars of a squirrel-cage rotor as that rotor experiences a rotating magnetic field from the stator windings of an induction motor. Refer to a photograph or picture of a squirrel-cage rotor, or point to the rotor bars of a real rotor, as you trace the directions of current with your fingers.

[file i03970](#)

Question 52

An electrician wires a reversing motor control circuit as follows:

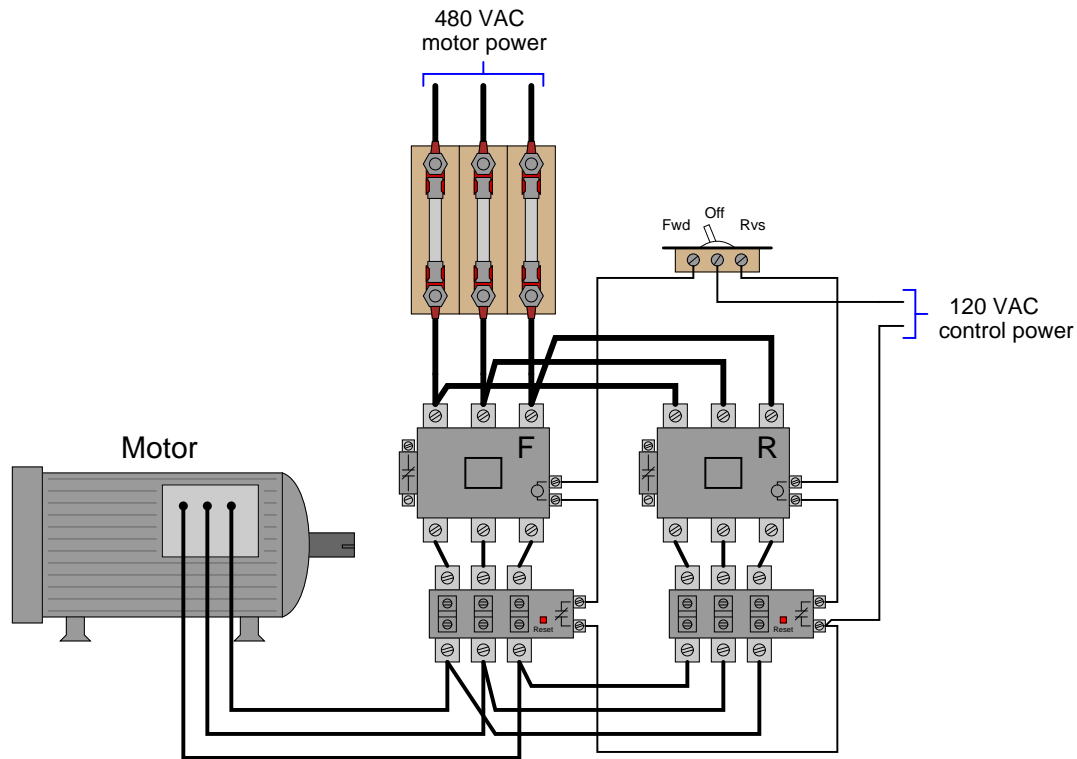

A wiser electrician warns the one who wired it that it is wrong to have multiple overload heater assemblies in a reversing motor control circuit. For one motor, he says, there should be only one overload heater block. The first electrician ignores the second one's advice, and puts this reversing motor control system in service.

Several months later, the motor fails from overheating, despite the overload heater elements being properly sized for this motor. Explain how it is possible for the motor to overheat in this system.

**Suggestions for Socratic discussion**

- How would *you* have chosen to communicate the flaw to the first electrician so that your advice would be better heeded?
- What is the proper way to wire a single thermal overload heater in a reversing motor control circuit so that the motor gets the protection it needs?
- What sort of operating scenario might stress this particular (mis-wired) motor more than others, given the improper overload heater installation?

[file i03499](#)

Question 53

Safety is a paramount concern in electrical systems. Generally, we try to design electrical circuits so that if and when they fail, they will do so in the manner safest to those people working around them, and to the equipment and process(es) controlled by the circuit.

One of the more common failure modes of circuits having wires strung through metal conduit is the *accidental ground*, or *ground fault*, where the electrical insulation surrounding a wire fails, resulting in contact between that wire and a grounded metal surface.

Suppose an accidental ground were to occur at the point shown in this ladder diagram:

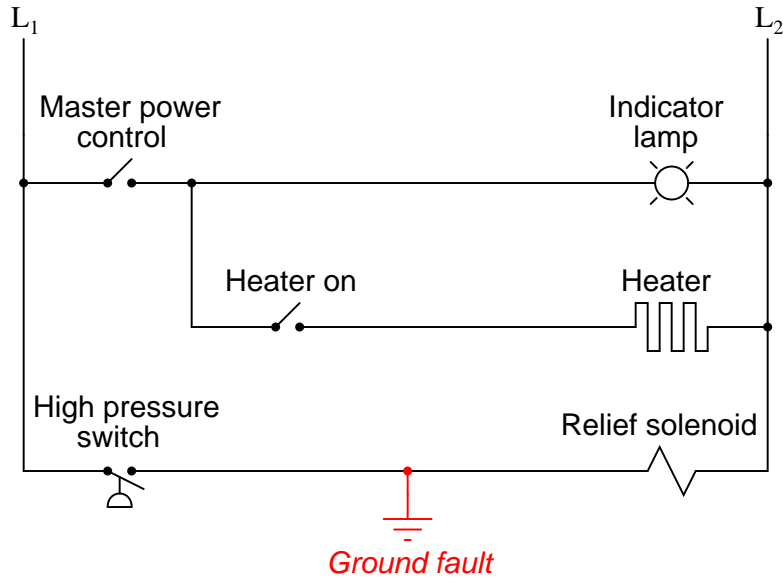

What would be the result of this fault? Hint: you will need to know something about the L<sub>1</sub>/L<sub>2</sub> power source in order to answer this question!

What would be the result if the L<sub>1</sub>/L<sub>2</sub> power connections were reversed?

[file i02313](#)



Question 54

Examine this motor control circuit for a *start/stop/jog* control:

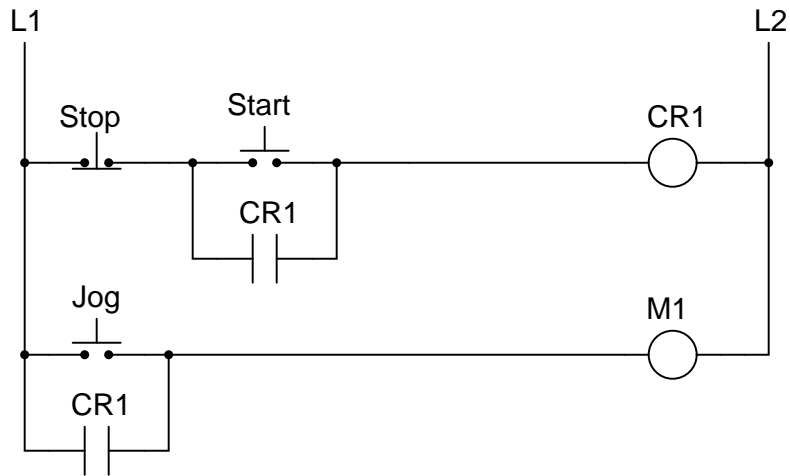

Explain in your own words what distinguishes the “Start” function from the “Jog” function, and think of a practical application where this might be useful.

[file i02459](#)

Question 55

Predict how the operation of this motor control circuit will be affected as a result of the following faults. Consider each fault independently (i.e. one at a time, no coincidental faults):

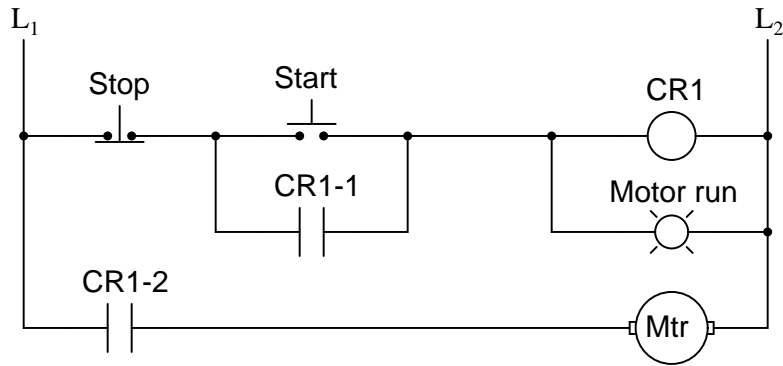

- “Stop” pushbutton switch fails open:
- Relay contact CR1-1 fails open:
- Relay contact CR1-2 fails open:
- Relay coil CR1 fails open:

For each of these conditions, explain *why* the resulting effects will occur.

**Suggestions for Socratic discussion**

- Is this a single-phase motor or a three-phase motor? How can you tell?
- What would need to be changed in this circuit to reverse the rotation of the motor?
- Suppose another technician suggests to you that the “Run” indicator lamp should be connected in parallel with the motor rather than in parallel with relay coil CR1. Do you think this is a good idea? Why or why not?
- Modify this circuit to include a “Jog” pushbutton switch that runs the motor when pressed but immediately stops the motor when released (i.e. no “latching” function).

[file i02321](#)

Question 56

Draw a ladder logic control circuit for the electric motor of an air compressor, controlled by two pressure switches: one switch turns the motor on when the pressure falls to 80 PSI, while the other switch turns the motor off when the pressure rises to 105 PSI:

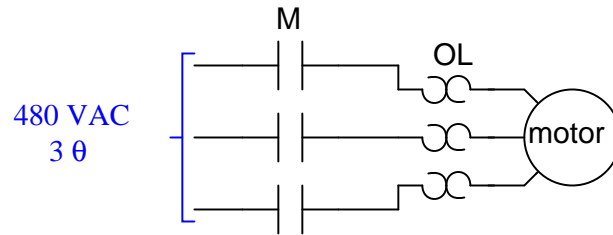

Be sure to include the overload (OL) contact in the 120 volt control circuit ( $L_1$  &  $L_2$ ), and include a manual on/off switch as well.

[file i00799](#)

Question 57

*Time-delay relays* are important circuit elements in many applications. Determine what each of the lamps will do in the following circuit when pushbutton “A” is pressed for 10 seconds and then released:

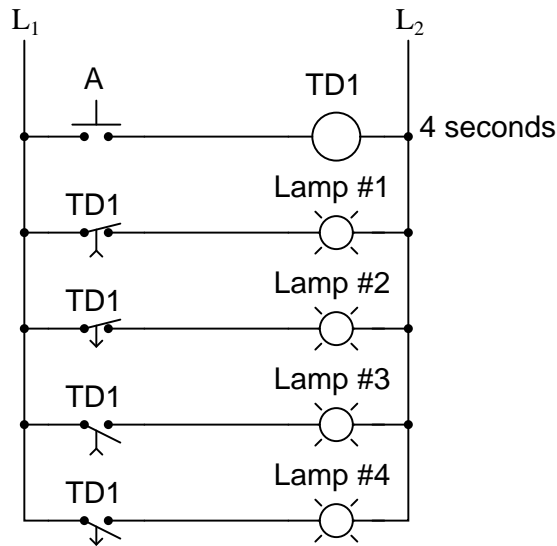

Show your answer by completing this timing diagram:

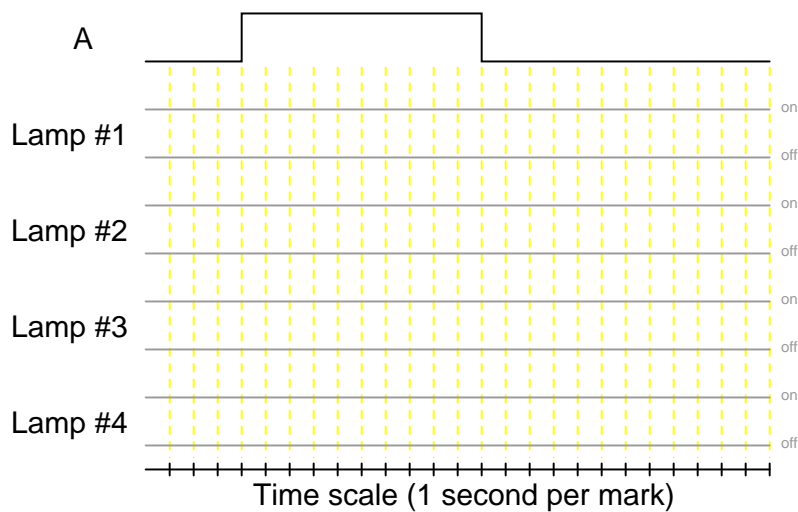

For each of the relay contacts shown in this circuit, identify whether it would be properly called an *on-delay* or an *off-delay* contact.

file i02500

Question 58

An electric motor is used to power a large conveyor belt. Before the motor actually starts, a warning siren activates to alert workers of the conveyor's forthcoming action. The following relay circuit accomplishes both tasks (motor control plus siren alert):

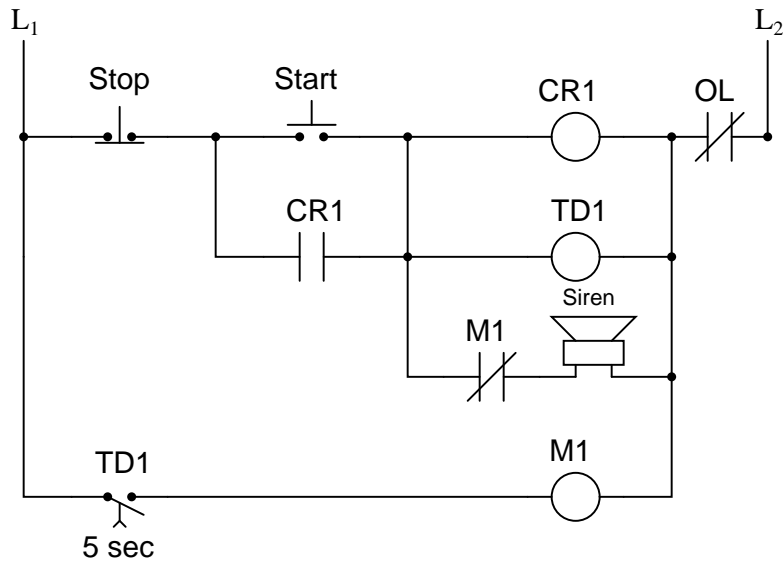

Study this ladder logic diagram, then explain how the system works.  
[file i02501](#)

Question 59

The following ladder logic diagram is for a reversing motor control circuit:

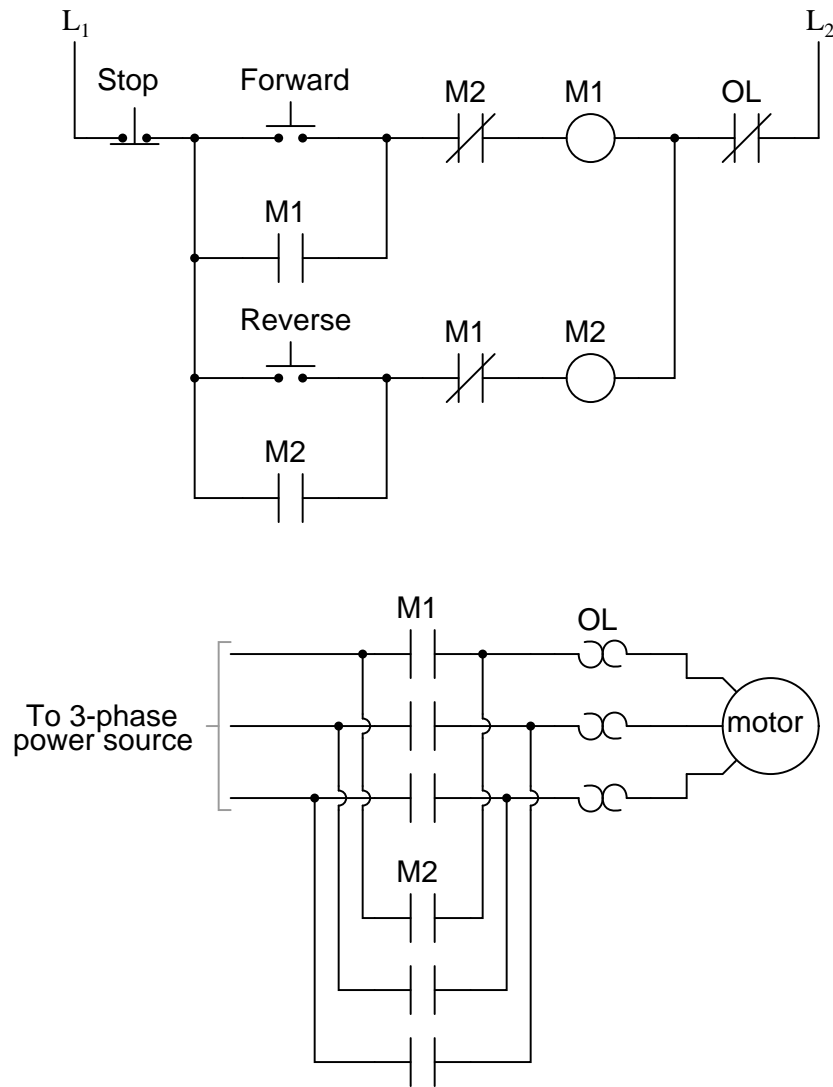

Study this diagram, then explain how motor reversal is accomplished. Also, identify the function of each "M" contact in the control circuit, especially those normally-closed contacts in series with the motor starter coils.

Now consider the following modification made to the reversing motor control circuit (motor and power contacts not shown here):

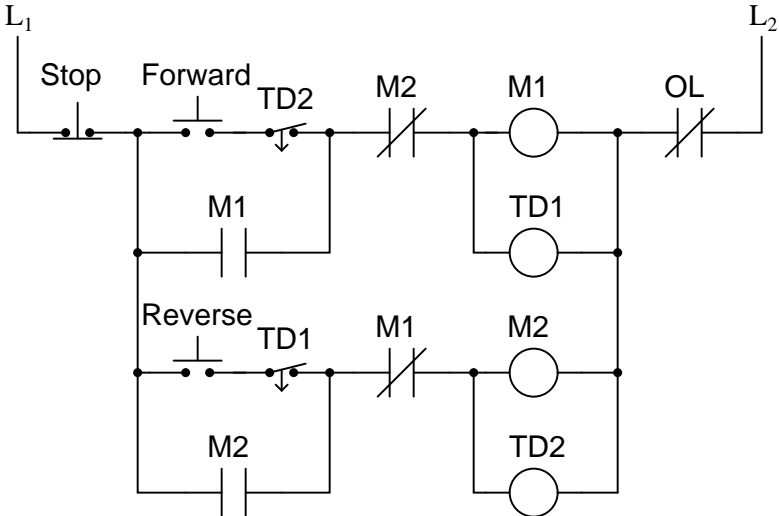

What extra functionality do the time-delay relays contribute to this motor control circuit?  
[file i02496](#)

Question 60

Draw the necessary wire connections to build the circuit shown in this ladder diagram:

Ladder diagram:

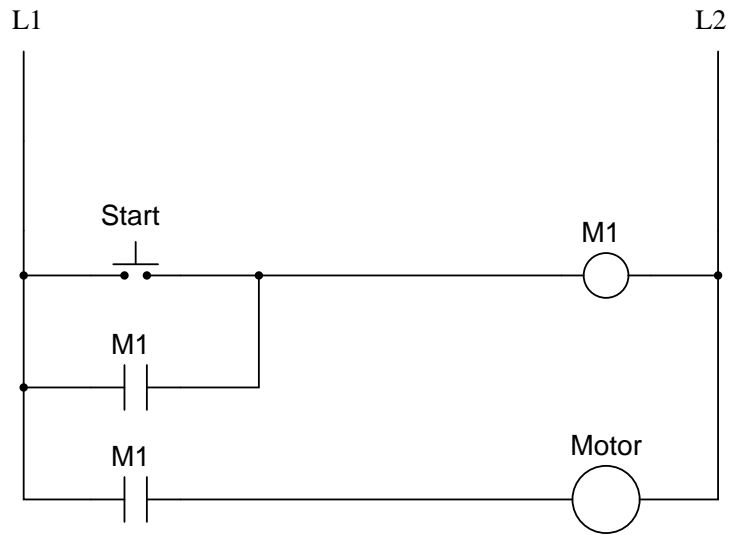
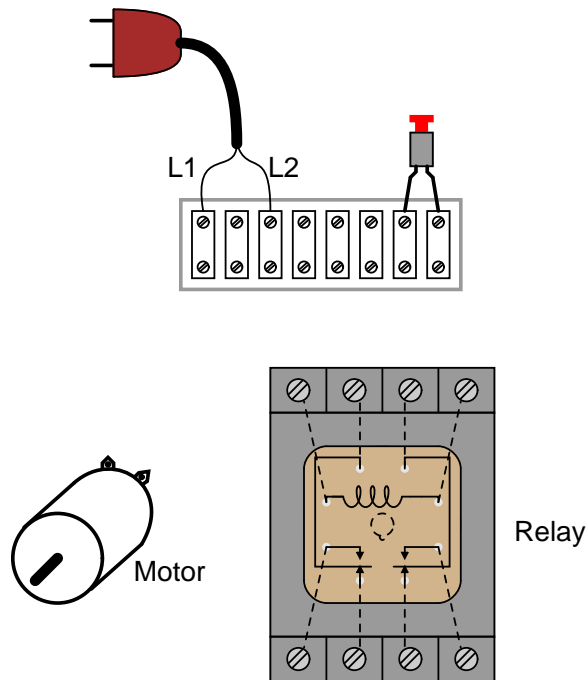

Illustration showing components:



*(Dashed lines represent connections between relay terminals and socket screw lugs, hidden from sight)*

[file i02305](#)



---

Question 61

On a job you are asked to disconnect a five-conductor cable from a terminal strip in preparation for that cable's complete removal. Another technician tells you that the other end of that cable has already been completely disconnected, and therefore there can be no dangerous voltage present on the cable.

Your next step is to confirm the absence of dangerous voltage on the conductors before physically touching any of them. This confirmation, of course, is done with a voltmeter, and we all know that voltage is measured *between two points*. The question now is, how many different combinations of points must you measure between to ensure there is *no* hazardous voltage present?

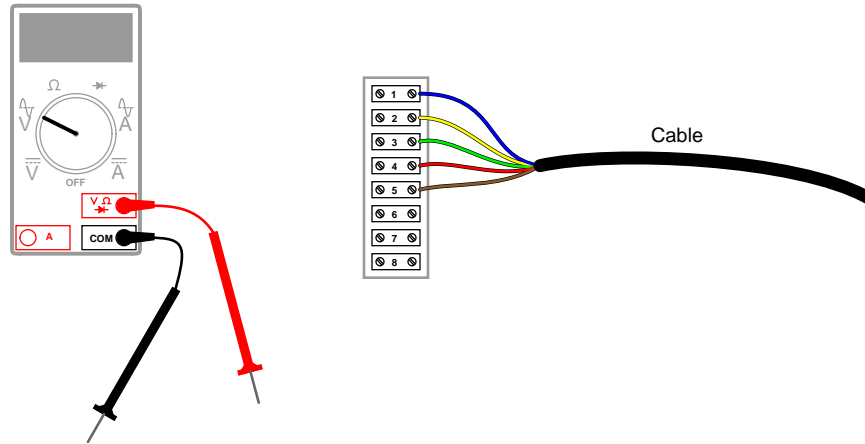

List all possible pairs of points you should test for voltage between, in order to ensure the conductors are safe for you to touch. Don't forget to include earth ground as one of those points!

Next, write a mathematical formula to calculate the number of point-pair combinations (i.e. the number of different voltage measurements that must be taken) given  $N$  number of connection points in the circuit.

Question 62

Complete the table of values for this circuit:

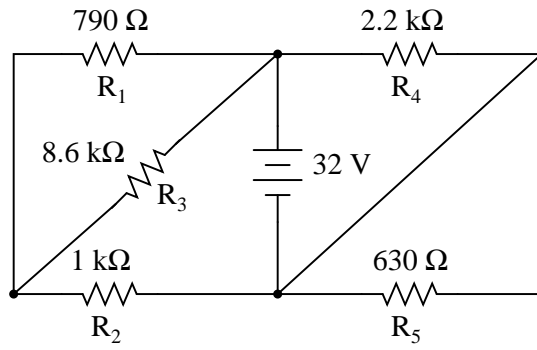

	R <sub>1</sub>	R <sub>2</sub>	R <sub>3</sub>	R <sub>4</sub>	R <sub>5</sub>	Total
V						
I						
R	790 Ω	1 kΩ	8.6 kΩ	2.2 kΩ	630 Ω	
P						

Question 63

Sketch connecting wires such that the relay will de-energize and turn on the lamp when the normally-closed (NC) pushbutton switch is pressed. Use the following schematic diagram as a guide:

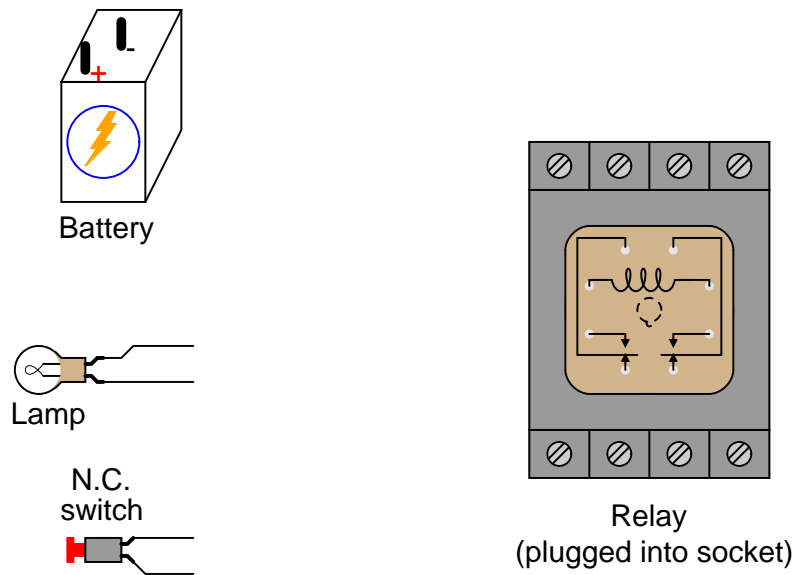

Schematic diagram

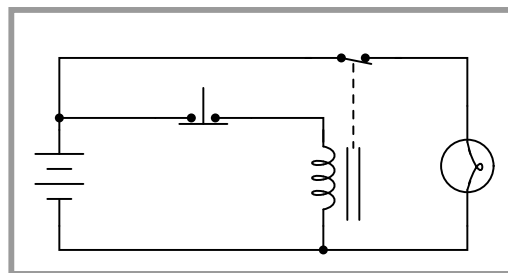

Note how the relay coil and lamp are separate (parallel) branches in this circuit. The pushbutton switch *only* carries coil current, while the relay's switch contact *only* carries lamp current.

Question 64

Examine this switch circuit and determine what process condition(s) must be met in order to turn the lamp on:

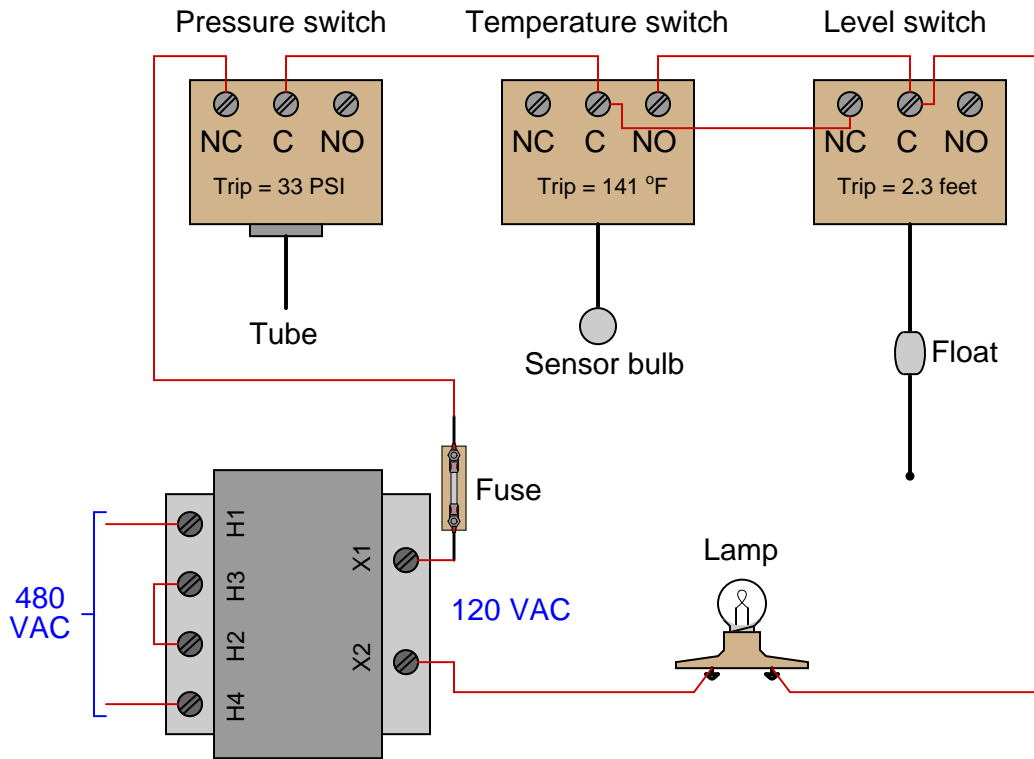

---

Question 65

An electrician brings a motor contactor to you for testing. She wants to be sure everything is in perfect working condition before she installs it into a new system:

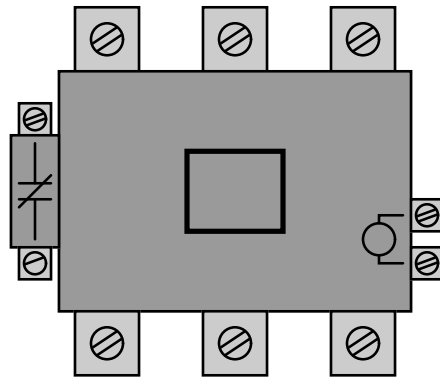

Explain in detail what you would do to thoroughly test this contactor on the bench. Be sure to address the following:

- Making sure the armature assembly moves freely
- Ensuring the coil is in good working order
- Ensuring all power contacts open as they should and close with low resistance
- Checking to see that the auxiliary contact is in good order

Question 66

The following relay circuit has a problem. The LED lamp never comes on, regardless of the amount of pressure or temperature sensed by the switches:

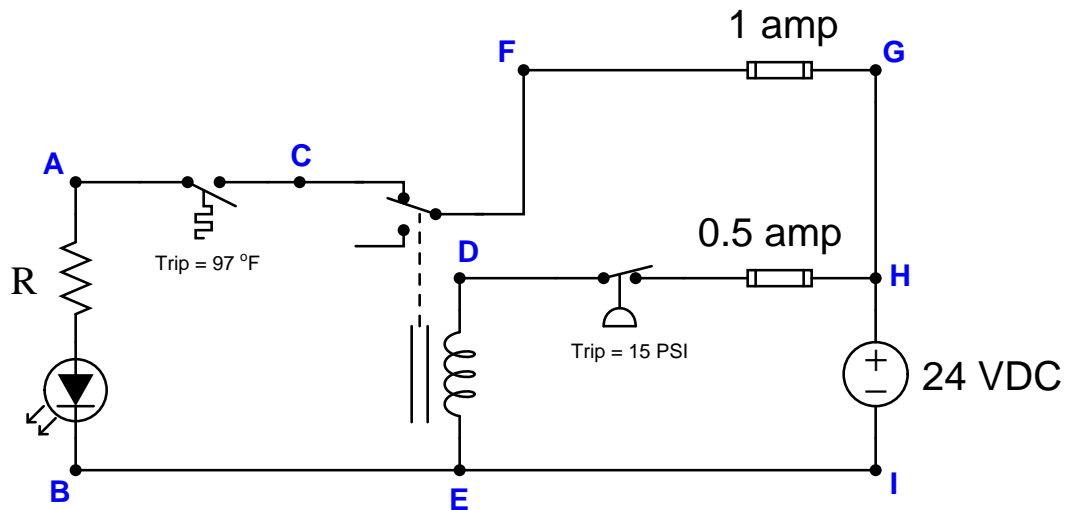

Using a digital multimeter, you measure 23.5 volts DC between points D and B when the temperature is 102 degrees F and the pressure is 18 PSI.

Identify the likelihood of each specified fault for this circuit. Consider each fault one at a time (i.e. no coincidental faults), determining whether or not each fault could independently account for *all* measurements and symptoms in this circuit.

Fault	Possible	Impossible
Pressure switch failed open		
Temperature switch failed open		
0.5 amp fuse blown		
1 amp fuse blown		
Relay coil failed open		
Pressure switch failed shorted		
Temperature switch failed shorted		
Relay coil failed shorted		

Finally, explain why no further diagnostic tests or measurements are necessary to identify the location and nature of the fault.

Question 67

The following variable-speed motor drive receives a variable DC voltage from a potentiometer as a speed-command signal from a human operator. In this case, the potentiometer's full range commands the motor to spin from 0 RPM to 1800 RPM (the wiper here is drawn in a position nearer 100% speed):

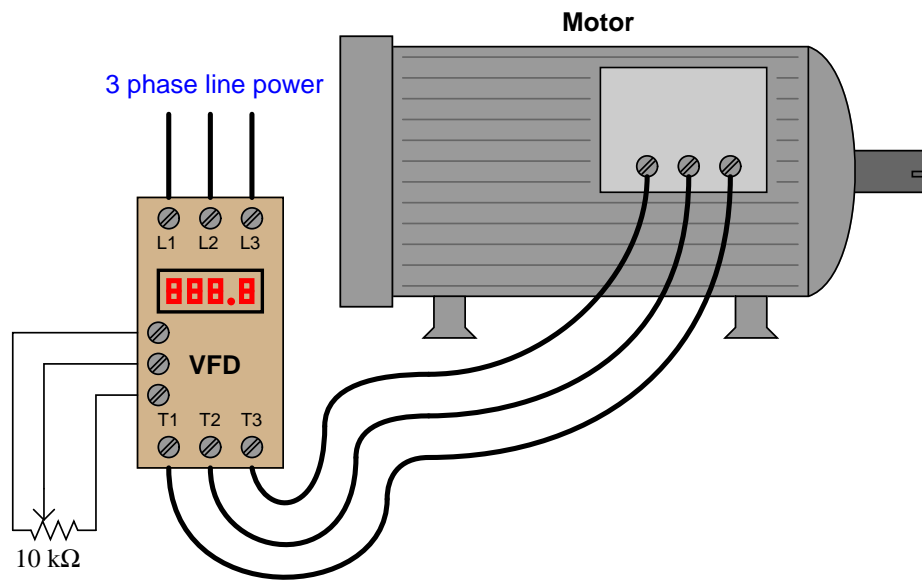

One day the operations manager approaches you to request you modify this speed-command system so that the operators cannot call for a speed less than 100 RPM or greater than 1670 RPM. You consult the manual for the motor drive, and are surprised to find it lacks this sort of capability: a resistance input of 0 to 10 kΩ will *only* translate to a speed range of 0 to 1800 RPM. This means you must figure out a way to set the adjustable speed range limits externally to the drive (i.e. by limiting the range of the potentiometer's resistance adjustment).

You know you cannot mechanically limit the turning of the potentiometer knob, but you can connect fixed-value resistors to the potentiometer to *electrically* limit its range, so that full clockwise will only command the drive to go as high as 1670 RPM, and full-counterclockwise will only command the drive to go as low as 100 RPM.

Modify this diagram to include any necessary fixed-value resistors, and also calculate their necessary values.

Question 68

A common “accessory” device for a variable-frequency drive (VFD) is a *line reactor*, which is nothing more than a large inductor connected in series with each of the motor drive’s power line conductors. The purpose of a line reactor is to act as a low-pass filter, allowing 60 Hz power to the VFD but blocking harmonic frequencies generated by the VFD from “corrupting” the AC power supply system.

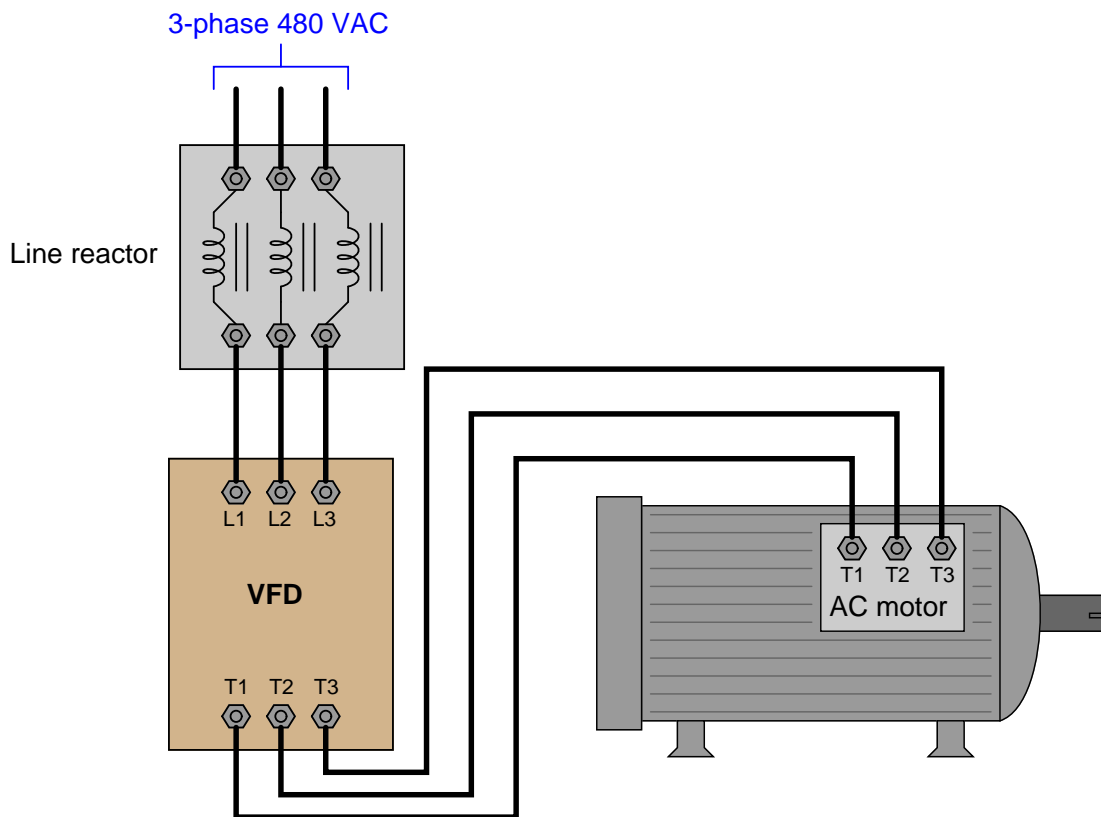

Suppose each winding of a line reactor for a 10 horsepower VFD has  $0.119 \Omega$  of resistance and  $1.5 \text{ mH}$  of inductance. Calculate the amount of *impedance* offered by each winding to the following harmonics:

Frequency ( $f$ )	Impedance ( $Z$ )
60 Hz (1st harmonic)	
180 Hz (3rd harmonic)	
300 Hz (5th harmonic)	
420 Hz (7th harmonic)	
540 Hz (9th harmonic)	

Hint: you may consider each reactor coil to be a series-connected inductor and resistor, together producing a certain amount of impedance for each frequency.



Question 69

This multi-voltage motor has been configured to operate on a power supply voltage of 480 VAC:

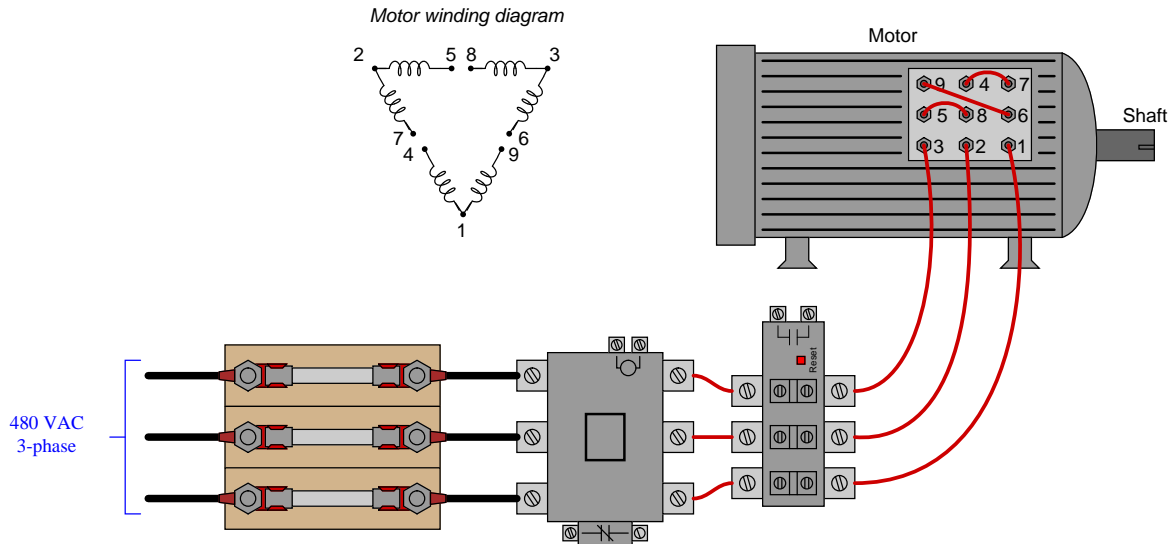

Calculate the amount of current through each individual winding of this motor, assuming a mechanical power output of 18.3 horsepower at an efficiency of 91%. Assume a power factor of 1 (unity).

Also, calculate the expected voltage drop between terminals 1 and 4 on the motor while it is running.

Question 70

A brand-new control system for a chemical reaction process uses a variable-frequency drive (VFD) to control the speed of the charge pump introducing chemical fluids into a reaction vessel. This VFD gets a 4-20 mA control signal from one of the channels of an analog output card on a programmable logic controller (PLC). The PLC in turn receives operating instructions from a touch-screen panel (“HMI”) where the operators can monitor and control the process:

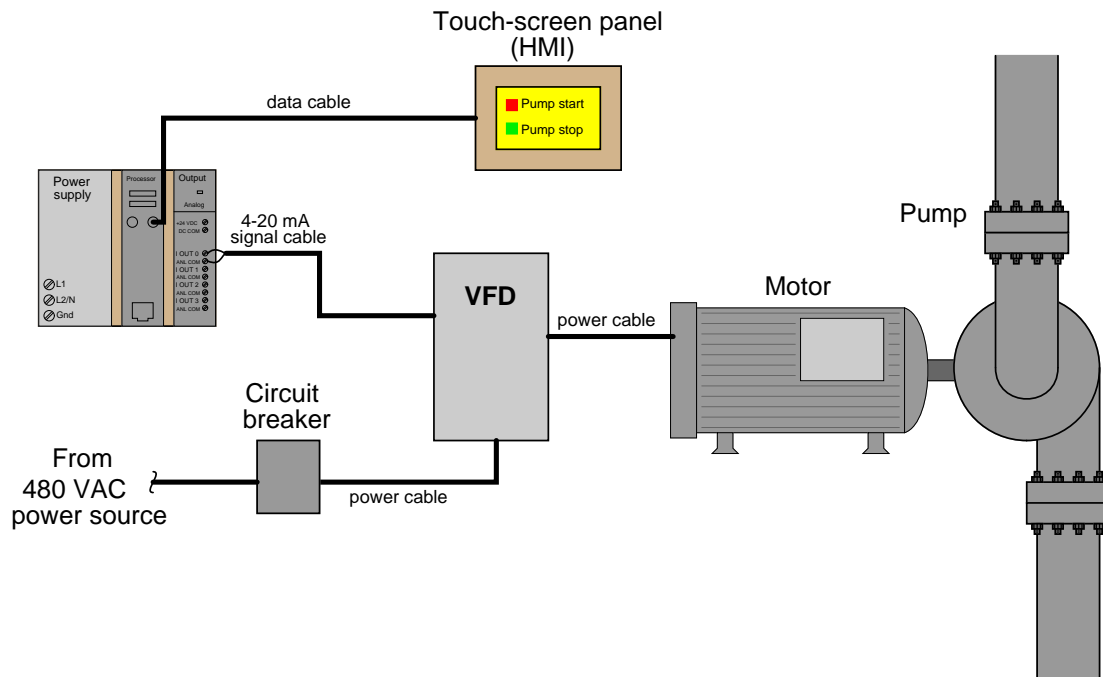

This system is newly constructed, and has not yet worked. The operators try starting up the pump by pressing the “Pump start” icon on the touch-screen, but nothing happens. A technician disconnects the signal cable from the PLC’s analog output terminals and then connects the cable’s end to a “loop calibrator” to send 12 mA DC to the VFD for a test. At this, the motor starts up and runs at half speed.

Identify the likelihood of each specified fault for this circuit. Consider each fault one at a time (i.e. no coincidental faults), determining whether or not each fault could independently account for *all* measurements and symptoms in this circuit.

Fault	Possible	Impossible
Circuit breaker off		
Touch-screen panel malfunctioning		
Programming error in PLC		
Faulted power cable between VFD and motor		
Faulted power cable between breaker and VFD		
Analog output card malfunctioning		
Shorted signal cable		

Finally, identify the *next* diagnostic test or measurement you would make on this system. Explain how the result(s) of this next test or measurement help further identify the location and/or nature of the fault.

file i00067

**Lab Exercise – introduction**

Your team’s task is to construct a three-phase reversing motor starter circuit, complete with a three-phase transformer bank to step between different voltage levels. You will also demonstrate proper safety precautions appropriate for working with three-phase power circuitry, including lock-out-tag-out and verification of safe conditions using a multimeter.

The following table of objectives show what you and your team must complete within the scheduled time for this lab exercise. Note how some of these objectives are individual, while others are for the team as a whole:

Objective completion table:

<b>Performance objective</b>	<b>Grading</b>	<b>1</b>	<b>2</b>	<b>3</b>	<b>4</b>	<b>Team</b>
Team meeting and prototype sketch (do <i>first!</i> )	mastery	–	–	–	–	
Circuit design challenge	mastery					-----
Final schematic diagram and system inspection	mastery					-----
Proper use of insulation tester	mastery					-----
Safety demonstrations	mastery					-----
Energized Electrical Work Permit (NFPA 70E)	mastery	–	–	–	–	
Transformer bank wiring inspection	mastery	–	–	–	–	
Proper motor control function	mastery	–	–	–	–	
Troubleshooting	mastery					-----
Lab question: Wiring connections	proportional					-----
Lab question: Commissioning	proportional					-----
Lab question: Mental math	proportional					-----
Lab question: Diagnostics	proportional					-----
Decommission and lab clean-up	mastery	–	–	–	–	
Personal tool kit complete (show on last day)	mastery					-----
Reply to email message on BTC account	mastery					-----

The only “proportional” scoring in this activity are the lab questions, which are answered by each student individually. A listing of potential lab questions are shown at the end of this worksheet question. The lab questions are intended to guide your labwork as much as they are intended to measure your comprehension, and as such the instructor may ask these questions of your team day by day, rather than all at once (on a single day).

In addition to this motor control system, you must individually construct a *PLC trainer* for learning PLC programming. An example is documented in the next question of this worksheet.

PLC objective completion table:

<b>Performance objective</b>	<b>Grading</b>	<b>1</b>	<b>2</b>	<b>3</b>	<b>4</b>	<b>Team</b>
All components unwired before construction	mastery					-----
All inputs (switches) function properly	mastery					-----
All outputs (lights) function properly	mastery					-----

**It is essential that your team plans ahead what to accomplish each day. A short (10 minute) team meeting at the beginning of each lab session is a good way to do this, reviewing what’s already been done, what’s left to do, and what assessments you should be ready for. There is a lot of work involved with building, documenting, and troubleshooting these working instrument systems!**

As you and your team work on this system, you will invariably encounter problems. You should always attempt to solve these problems as a team before requesting instructor assistance. If you still require instructor assistance, write your team's color on the lab whiteboard with a brief description of what you need help on. The instructor will meet with each team in order they appear on the whiteboard to address these problems.

## Lab Exercise – team meeting, prototype sketch, and instrument selection

An important first step in completing this lab exercise is to **meet with your instructor** as a team to discuss safety concerns, team performance, and specific roles for team members. If you would like to emphasize exposure to certain equipment (e.g. use a particular type of control system, certain power tools), techniques (e.g. fabrication), or tasks to improve your skill set, this is the time to make requests of your team so that your learning during this project will be maximized.

An absolutely essential step in completing this lab exercise is to work together as a team to **sketch a prototype diagram** showing what you intend to build. This usually takes the form of a simple electrical schematic and/or loop diagram showing all electrical connections between components, as well as any tubing or piping for fluids. This prototype sketch need not be exhaustive in detail, but it does need to show enough detail for the instructor to determine if all components will be correctly connected for their safe function.

You should practice good problem-solving techniques when creating your prototype sketch, such as consulting equipment manuals for information on component functions and marking directions of electric current, voltage polarities, and identifying electrical sources/loads. Use this task as an opportunity to strengthen your analytical skills! Remember that you will be challenged in this program to do all of this on your own (during “capstone” assessments), so do not make the mistake of relying on your teammates to figure this out for you – instead, treat this as a problem *you* must solve and compare your results with those of your teammates.

Your team’s prototype sketch is so important that the instructor will demand you provide this plan before any construction on your team’s working system begins. *Any team found constructing their system without a verified plan will be ordered to cease construction and not resume until a prototype plan has been drafted and approved!* Similarly, you should not deviate from the prototype design without instructor approval, to ensure nothing will be done to harm equipment by way of incorrect connections. Each member on the team should have ready access to this plan (ideally possessing their own copy of the plan) throughout the construction process. Prototype design sketching is a skill and a habit you should cultivate in school and take with you in your new career.

When selecting components for this lab exercise, you will need to choose a step-down “control power” transformer, a pair of three-phase contactors (one for forward and one for reverse), and an overload “heater” assembly. A three-pushbutton Forward/Reverse/Stop control station has already been constructed for you, having four wires ready to connect to your motor starter assembly:

**Pushbutton switch station wiring diagram**

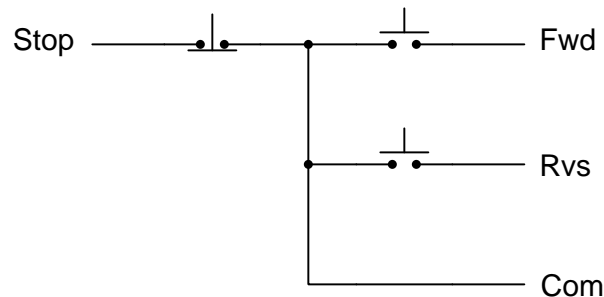

After locating suitable components, you should qualitatively test them prior to construction of your system. For an electric motor, this means checking continuity through all the windings. For switches, ohmmeter (“continuity”) measurements will tell you if the switch contacts are actuating as they should. For the contactor, you may manually actuate the contacts and also check the contacts and coil for continuity using your ohmmeter. If any component fails to respond properly, notify the instructor and then tag it with a label explaining what it does (or what it fails to do).

Another detail important to the planning of your system is identifying the necessary gauge (size) of the wires used. Consult article 310 of the National Electrical Code (the “NEC,” also known as *NFPA 70*)

book regarding “ampacity” ratings for different gauges of stranded copper wire. Your motor’s nameplate will provide the information you will need on line current.

**Planning a functioning system should take no more than an hour if the team is working efficiently, and will save you hours of frustration (and possible component destruction!).**

## Lab Exercise – circuit design challenge

Connect an “ice-cube” relay to a low-voltage DC source as well as 120 volts AC so that a hand-operated switch will control the energization of a 120 VAC load. All electrical connections must be made using a terminal strip (no twisted wires, crimp splices, wire nuts, spring clips, or “alligator” clips permitted), and the 120 VAC portion of the circuit must be fused for overcurrent protection.

This exercise tests your ability to properly interpret the “pinout” of an electromechanical relay, properly wire a switch to control a relay’s coil, properly wire a load to the contacts of a relay, properly select NO/NC contacts on both the switch and the relay, and use a terminal strip to organize all electrical connections.

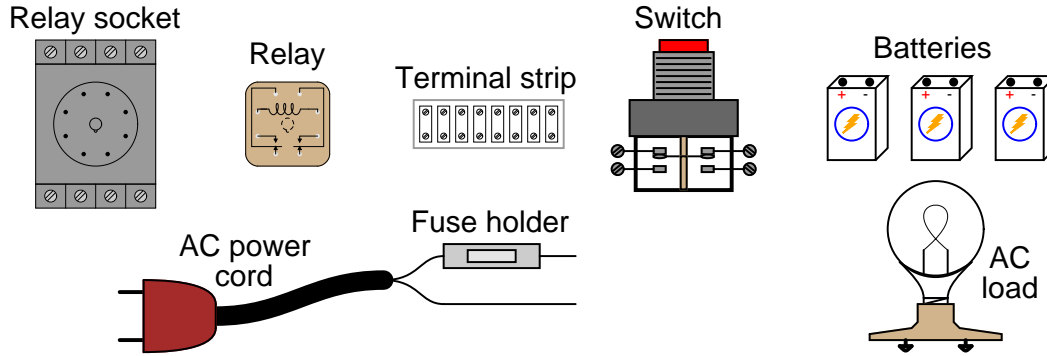

The following components and materials will be available to you: assorted “ice cube” **relays** with DC-rated coils and matching **sockets** ; assorted pushbutton **switches** ; **terminal strips** ; lengths of **hook-up wire** ; **battery clips** (holders) ; 120 VAC **power cord** with **fuse assembly** ; 120 VAC **lamp** or other **suitable load**.

You will be expected to supply your own screwdrivers and multimeter for assembling and testing the circuit at your desk, as well as a copy of this page for your instructor to mark conditions. The instructor will supply the battery(ies) to power your circuit when you are ready to see if it works. Until that time, your circuit will remain unpowered.

**Load/switch status** (instructor chooses):    \_\_\_ On when pressed    *or*    \_\_\_ Off when pressed

Study reference: the “Control Relays” section of *Lessons In Industrial Instrumentation*.

## Lab Exercise – documenting the system

Given the hazards associated with three-phase AC power circuitry, it is essential that you carefully plan your circuit in its entirety prior to assembling it. For this reason, the instructor will require a complete, detailed schematic diagram of your motor starter circuit. These diagrams must be thoroughly checked for accuracy and electrical safety, to ensure no unnecessary hazards are present when power is applied.

A sample schematic diagram for a one-direction motor starter circuit is shown on the next page. Your schematic diagram must be *comprehensive* and *detailed*, showing every wire connection, every cable, every terminal block, etc. The principle to keep in mind here is to make the schematic diagram so complete and unambiguous that anyone can follow it to see what connects to what, even someone unfamiliar with motor control circuits. In industry, systems are often constructed by contract personnel with limited understanding of how the system is supposed to function. The schematic diagrams they follow must be so complete that they will be able to connect everything properly without necessarily understanding how it is supposed to work.

Note that each and every wire in your system needs to be labeled with a number. Wires electrically common to each other at all times (i.e. connected at terminal blocks, not passing through any component) must bear the same label number. An easy way to label wires is to wrap a short piece of masking tape around each wire then writing on that masking tape with a permanent marker. Furthermore, each number or other label appearing on a device terminal (e.g. the screw terminals on an octal-base relay socket) must be shown on your schematic diagram in parentheses, to distinguish those labels from wire numbers used to identify wires. With each wire and each device terminal clearly labeled, one cannot go wrong in re-connecting wires that were undone. This is important when technicians remove components for repair and replacement, as the schematic diagram is their only guide to proper re-connection of the new or repaired components.

When your entire team is finished drafting your individual schematic diagrams, call the instructor to do an inspection of the system. Here, the instructor will have students take turns going through the entire system, with the other students checking their diagrams for errors and omissions along the way. During this time the instructor will also inspect the quality of the installation, identifying problems such as frayed wires, improperly crimped terminals, poor cable routing, missing labels, lack of wire duct covers, etc. The team must correct all identified errors in order to receive credit for their system.

After successfully passing the inspection, each team member needs to place their schematic diagram in the diagram holder located in the middle of the lab behind the main control panel. When it comes time to troubleshoot another team's system, this is where you will go to find a schematic diagram for that system!



Note that this sample diagram is shown only to illustrate the conventions you should use in documenting wire labels, terminal labels, etc. Your team's diagram will differ substantially from this one, most notably because it is a reversing motor control circuit whereas this example diagram shows a one-directional motor control circuit:

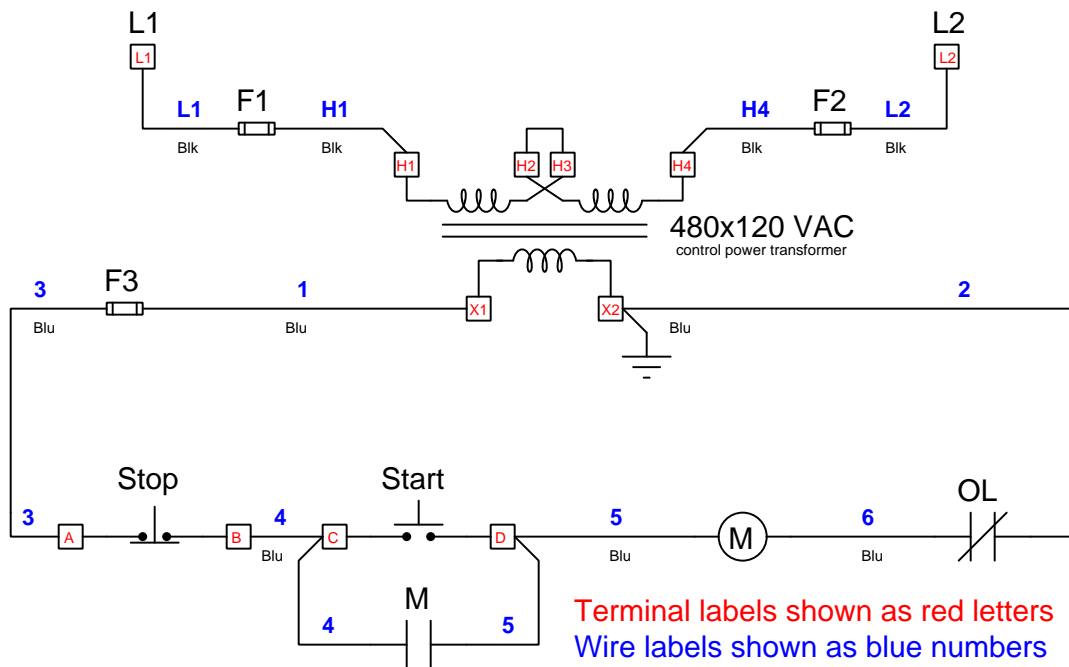

Reversing motor control circuits always contain normally-closed *interlocking* relay contacts to prevent simultaneous energization of both “Forward” and “Reverse” contactors. The one-direction motor control circuit shown above lacks interlock contacts, because there is only one direction it can turn.

Feel free to consult the “Typical Wiring Diagrams” booklet produced by Allen-Bradley for manual and magnetic full-voltage starter units, contained on your Instrumentation Reference. This booklet shows a wide variety of starter circuit configurations, including diagrams for reversing starter circuits.

Note that wiring diagrams for motor control circuits often take two forms: *schematic* and *pictorial*. Schematic diagrams are laid out in such a way as to minimize the number of wire crossings, in order to aid visual analysis of the circuit. Pictorial diagrams, on the other hand, are laid out in a manner resembling the physical orientation of circuit components, and therefore typically are more difficult to analyze because there are many more wires crossing over each other in order to reach their intended terminal points. It is highly recommended that you make your diagrams *schematic* rather than pictorial, especially for ease of interpretation when you do troubleshooting on motor control circuits and must use the diagram to determine your diagnostic tests.

#### Common mistakes:

- Copying (verbatim) a sample diagram from a book, rather than customizing the diagram for the components at hand.
- Basing your diagram off of a team-mate’s diagram, rather than closely inspecting the system for yourself.
- Forgetting to label all wires (see example diagram).
- Forgetting to label all terminals (see example diagram).
- Forgetting to note all wire colors.
- Forgetting to put your name on the schematic diagram!

**Creating and inspecting accurate schematic diagrams should take no more than one full lab session (3 hours) if the team is working efficiently!**

## Lab Exercise – building the system

After getting your wiring diagram approved by the instructor, you are cleared to begin building your system. Mount all control components (control power transformer, contactors, overload unit, fuse holders) on a metal subpanel (plate) designed to insert into an electrical enclosure. Locate the pushbutton switched at some other location such as the main control panel for the lab. This ensures a long enough cable run for the switches to make the system realistic for testing and troubleshooting. Note: you must marshall all switch wiring through terminal blocks on the subpanel, so that the switches may be disconnected from the rest of the control circuit without disturbing any other wiring.

Power to your control circuit will come through four terminals located at one edge of the metal subpanel: three fused terminals for the three-phase power lines (L1, L2, and L3), and one unfused terminal for earth (safety) ground which will be bonded to the metal subpanel. Plastic “wire duct” will be used to route all wires between components. Here is a model layout (note that yours may look different):

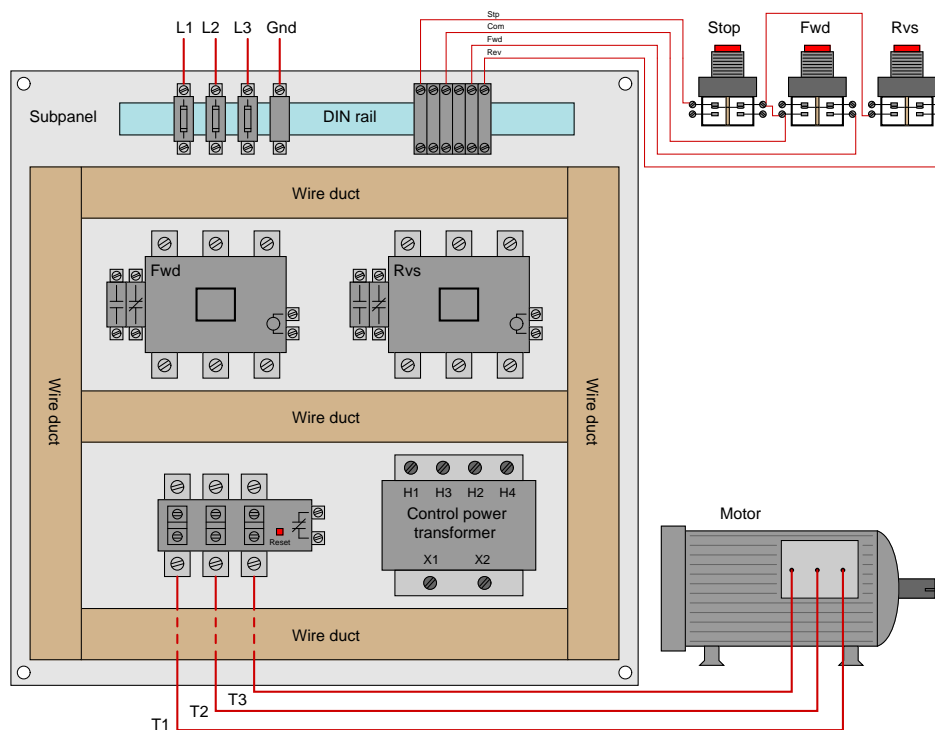

All wires need to enter and exit the wire duct perpendicularly for a neat and professional appearance. All conductors must be stranded copper, of sufficient gauge for the full-load motor current according to the National Electrical Code (NEC). Each wire should bear its number label at each end where it terminates.

Before applying power to your motor control starter circuit, it must be inspected under instructor supervision. Testing will be performed using a high-voltage insulation tester (sometimes called a “Megger” in honor of a proper brand name for this type of instrument) to check for proper connections, proper fuse operation (i.e. when a fuse is pulled out of its socket, continuity to the protected device is interrupted), etc.

### Common mistakes:

- Failing to tug on each and every wire where it terminates to ensure a mechanically sound connection.
- Students working on portions of the system in isolation, not sharing with their teammates what they did and how. It is important that the whole team learns all aspects of their system!

**Building a functioning system should take no more than one full lab session (3 hours) if all components are readily available and the team is working efficiently!**

## Lab Exercise – insulation tester usage

An *insulation tester* is a special kind of ohmmeter designed to detect high-resistance paths for electric current (in the hundreds of megaohms). The purpose of using an insulation tester when checking the integrity of electric motors and motor control circuits is to reveal any breakdowns of electrical insulation that might not otherwise be detected using a regular low-range ohmmeter.

What makes an insulation tester different from a regular ohmmeter is its use of relatively high voltage to perform the test. Unlike a regular ohmmeter which only applies a few volts (or even just a few tenths of a volt for many modern DMM ohmmeter functions) to the circuit under test, an insulation tester contains within it a high-voltage generator capable of supplying hundreds or even thousands of volts to the test leads in order to “stress” the circuit under test and reveal any breakdown of insulation. This makes an insulation tester capable of delivering an electrical shock to the user if incorrectly operated!

Legacy insulation testers, especially the “Megger” brand whose name has become synonymous with insulation test instruments, used hand-crank electromechanical generators to create this high voltage. Early “Megger” testers actually had a small crank handle protruding from the side which the user would turn after having connected the test leads to the circuit. If something went wrong and the user became shocked by the tester’s output voltage, they would naturally stop cranking the handle. Modern insulation testers have battery-powered high voltage generator circuits, and use a pushbutton to trigger the application of high voltage to the circuit under test. Again, the notion being that anyone shocked by the output of the instrument will naturally stop pressing the button.

All insulation testers have rather high output impedance, so that when connected across a short-circuit the high-voltage power source inside the tester will not be damaged by excessive current. This makes insulation testers perfectly valid for testing continuity in addition to testing for the presence of non-continuity (i.e. that conductors are insulated from each other).

Most insulation testers provide a way to vary the amount of voltage output by the tester, for different testing applications. When using an insulation tester, you want to use a test voltage greater than that normally experienced by the device or circuit under test, in order to adequately “stress” that device or circuit to ensure its proper operation when energized by its normal supply voltage. However, you do not want to use so much voltage that you actually cause damage to the device or circuit under test! This means the tester’s output voltage should be configured to be *just one step above the circuit’s normal operating voltage*.

Devices most susceptible to damage from mis-use of an insulation tester are *semiconducting* in nature. Diodes, transistors, SRCs, TRIACs, and associated devices may all be damaged rather easily by the mis-application of an insulation tester. This means one should not use an insulation tester on a circuit containing complex and expensive semiconductor components such as variable-speed motor drives (VSDs or VFDs).

### **Lab Exercise – safety demonstrations**

This lab exercise, more than any other, harbors a significant level of personal danger due to the use of 480 VAC power. Exercising safe work habits is not just an objective of this lab, but it is essential for avoiding injury! This lab requires you to demonstrate the following procedures:

- The one-hand rule (working only with your right hand – keeping the left hand in a pocket or behind your back – when working on any energized circuit)
- Lock-out, Tag-out (properly documenting work to be done on a tag, then attaching both tag and lock to the disconnect device securing power)
- Attempt to start the motor (as a crude check to see that power has been disconnected)
- Proper use of meter to check for dangerous voltage (check for voltage between all possible pairs of points – including earth ground – and then verifying the meter’s operation against a known voltage source)

## Lab Exercise – complete an Energized Electrical Work Permit

The NFPA 70E document provides a sample Energized Electrical Work Permit. Your team will print or photocopy this sample work permit and complete it for a specific job assignment selected by your instructor. Job examples include, but are not limited to:

- Attaching 4-20 mA wires to the back of a panel-mounted loop controller while the controller is powered by 120 VAC.
- Using a multimeter to take voltage measurements on a 208 VAC motor starter circuit while it is powered through the step-down transformer bank in our lab.
- Using a multimeter to take voltage measurements on the 480 VAC lines feeding the step-down transformer bank in our lab.
- Using a multimeter to take voltage measurements on a live 480 VAC motor starter circuit fed directly from a three-phase transformer with a specified MVA rating.
- Using a multimeter to take voltage measurements on a VFD while it is powered through an isolation transformer of specified KVA rating (just like some of the VFDs in our lab).
- “Racking in” a 4160 VAC circuit breaker into a live panel.
- Using a clamp-on ammeter to measure current through a line feeding a 480 VAC motor.

For every quantitative portion of the permit (e.g. calculating approach boundary distances) you must show the calculations used or tables referenced from the NFPA 70E standard.

## Lab Exercise – wiring the step-down transformer bank

In order to power your 240 VAC or 208 VAC motor from the 480 VAC receptacle in the lab, or to step up the 120 VAC three-phase power from our miniature AC power grid system to 208, 240, 416, or 480 volts to run the motor, you will need to wire three transformers together to create a three-phase transformer bank. Here are your configuration options, based on the different possible primary/secondary voltage ratings available for the transformers:

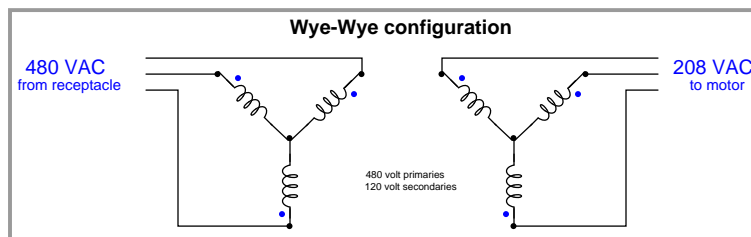
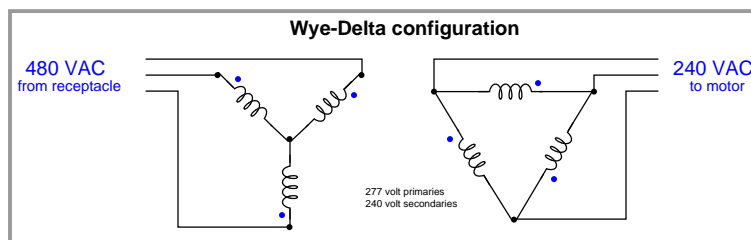
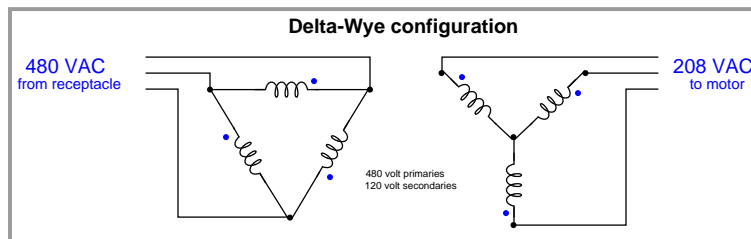
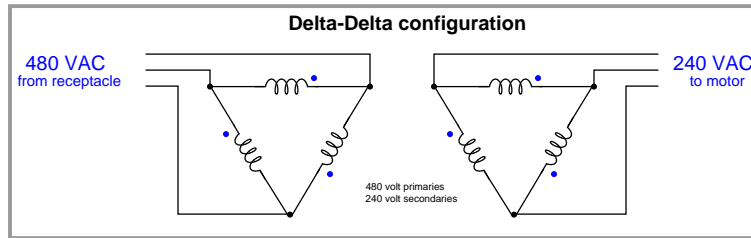

Multiple wiring options are possible depending on the rating of your motor, the power source used, and the particular transformers employed in this three-phase bank. Your instructor may prescribe one of these wiring configurations, or alternatively specify input and output line voltages and let you as a team choose the appropriate configuration.

After this, you must work as a team to determine the proper phasing (“polarity”) for the transformers and then connect the necessary wires in order to build the desired circuit. You may find the section titled “Transformer Polarity” in your *Lessons In Industrial Instrumentation* textbook helpful in explaining this concept. The instructor must inspect your plan as well as the constructed circuit before you are allowed to apply power to the transformer bank.

The following pictorial diagram might be useful for you and your team to use for sketching the necessary Delta/Wye connections and transformer winding jumpers to achieve the necessary step-down ratios:

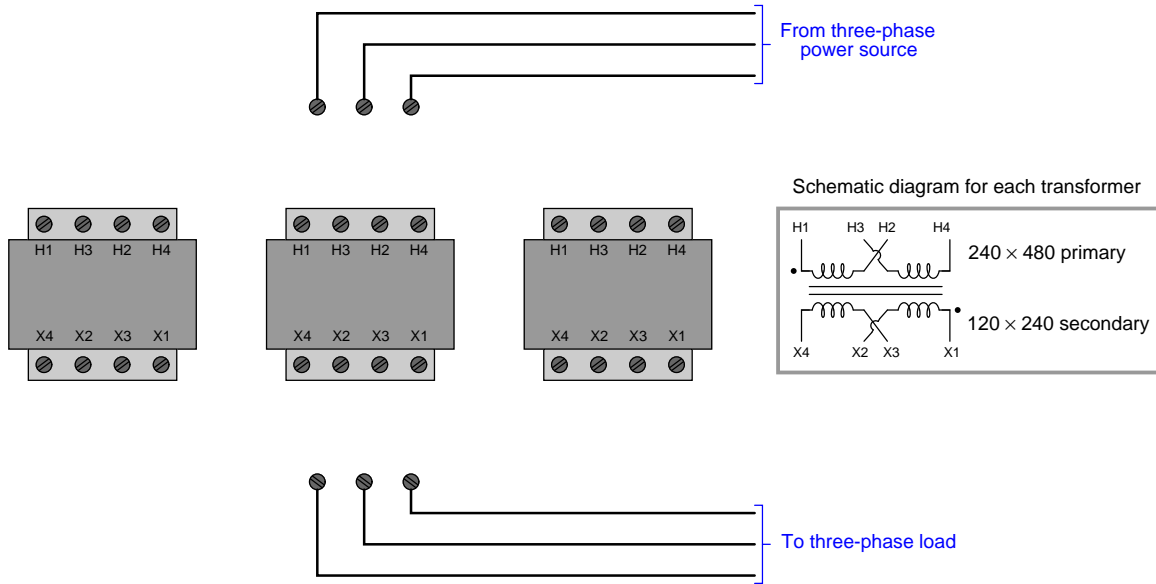

If you need to step voltage up from 120 VAC to something greater, it is permissible to run the transformers “backwards” by applying power to the lower-voltage “secondary” sides (using that side as the primary winding) and connecting the higher-voltage “primary” sides to your motor starter. The essential limitation is that no winding’s voltage or current ratings be exceeded at any time.

## Lab Exercise – troubleshooting

The most challenging aspect of this lab exercise is *troubleshooting*, where you demonstrate your ability to logically isolate a problem in the system. All troubleshooting is done on an individual basis (no team credit!), and must be done *on a system you did not help build*, so that you must rely on schematic diagrams to find your way around the system instead of from your own memory of building it.

Each student is given a limited amount of time to identify both the general location and nature of the fault, logically justifying all diagnostic steps taken. All troubleshooting activities will take place under direct instructor supervision to ensure students are working independently and efficiently.

Failure to correctly identify both the general location and nature of the fault within the allotted time, and/or failing to demonstrate rational diagnostic procedure to the supervising instructor will disqualify the effort, in which case the student must re-try with a different fault. Multiple re-tries are permitted with no reduction in grade.

A standard multimeter is the only test equipment allowed during the time limit. No diagnostic circuit breaks are allowed except by instructor permission, and then only after correctly explaining what trouble this could cause in a real system.

The instructor will review each troubleshooting effort after completion, highlighting good and bad points for the purpose of learning. Troubleshooting is a skill born of practice and failure, so do not be disappointed in yourself if you must make multiple attempts to pass! One of the important life-lessons embedded in this activity is how to deal with failure, because it *will* eventually happen to you on the job! There is no dishonor in failing to properly diagnose a fault after doing your level best. The only dishonor is in taking shortcuts or in giving up.

### Common mistakes:

- Neglecting to take measurements with your multimeter.
- Neglecting to check other measurements in the system (e.g. pressure gauge readings).
- Incorrectly interpreting the wiring diagram (e.g. thinking you're at the wrong place in the system when taking measurements).
- Incorrect multimeter usage (e.g. AC rather than DC, wrong range, wrong test lead placement). This is especially true when a student comes to lab unprepared and must borrow someone else's meter that is different from theirs!

**Remember that the purpose of the troubleshooting exercise is to foster and assess your ability to intelligently diagnose a complex system. Finding the fault by luck, or by trial-and-error inspection, is not a successful demonstration of skill. The only thing that counts as competence is your demonstrated ability to logically analyze and isolate the problem, correctly explaining all your steps!**

Troubleshooting takes a lot of lab time, usually at least two 3-hour lab sessions for everyone in a full class to successfully pass. Be sure your team budgets for this amount of time as you plan your work, and also be sure to take advantage of your freedom to observe others as they troubleshoot, to better learn this art.



## Lab questions

- **Wiring connections**
- Determine correct wire connections between components to create a working 3-phase motor control circuit, based on diagrams of components with terminals labeled
  
- **Commissioning and Documentation**
- Explain the meanings of the various ratings specified on a motor nameplate
- Explain the meanings of the coil and contact ratings specified on a contactor nameplate
- Explain how an *insulation tester* may be used to test the integrity of an electric motor's windings
- Explain how an *insulation tester* might cause damage to circuit components if improperly used
- Explain how to configure a multi-voltage induction motor for different operating voltages, given the information shown on a motor nameplate
- Explain what *arc flash* and *arc blast* are, and what causes these effects
- Explain how *overload heaters* in a motor control circuit perform a function fundamentally different from a fuse or a circuit breaker
  
- **Mental math** (no calculator allowed!)
- Convert horsepower rating of a three-phase AC electric motor into a current rating (at a specified line voltage)
- Convert current rating of a three-phase AC electric motor into a horsepower rating (at a specified line voltage)
  
- **Diagnostics**
- Determine whether or not a given diagnostic test will provide useful information, given a set of symptoms exhibited by a failed system
- Identify at least two plausible faults given the results of a diagnostic test and a set of symptoms exhibited by a failed system
- Propose a diagnostic test for troubleshooting a failed system and then explain the meanings of two different test results

### **Lab Exercise – decommissioning and clean-up**

The final step of this lab exercise is to decommission your team's entire system and re-stock certain components back to their proper storage locations, the purpose of which being to prepare the lab for the next lab exercise. Remove your system documentation (e.g. wiring diagram) from the common holding area, either discarding it or keeping it for your own records. Also, remove all wire labels from wiring and cables.

#### **Leave the following components in place, mounted on the racks:**

- Large electric motors
- Large variable-frequency drive (VFD) units
- Cables inside conduit interconnecting junction boxes together
- Pipe and tube fittings (do not unscrew pipe threads)
- Supply air pressure regulators

#### **Return the following components to their proper storage locations:**

- Manual (e.g. pushbutton) switches
- “Jumper” cables used to connect terminal blocks within a single junction box
- Power cables and extension cords

## Lab Exercise – tool kit and email usage

Two additional objectives that are not technically a part of making this lab project function, but are nevertheless very important to your continued success in the Instrumentation program, include assembling a personal tool kit and using your BTC email account (which is automatically created for every student at the college).

You will be using your tool kit throughout the remainder of this program, and so it is very important to have it complete and ready to use by the end of this lab exercise. Note that there are several optional items listed in addition to mandatory items. These optional tools are useful, but not 100% necessary for the work you will be doing in the lab. Also note that there are some consumable items in your tool list such as electrical compression terminals which you will need to keep stocked as you use them in your labwork.

Likewise, you will be relying on email to receive important messages from your instructor(s) throughout the remainder of the program. These messages include, but are not limited to, job announcements, guest speaker appearances, schedule changes, emergency notifications, scholarship announcements, and feedback on your personal performance in the program. The reason we use email as opposed to using learning management software is because it is imperative you learn how to appropriately use email for your chosen career. Email is simply the most common and most practical medium businesses use for day-to-day electronic communication.

Every BTC student is automatically given an email account upon registration, and this account remains active for some time after graduation. If you would rather not add one more email account to your electronic life, there is the option of having all messages received in your BTC email inbox automatically forwarded to the email platform of your choice (Yahoo, Hotmail, Gmail, Live, etc.) which may be selected as an option within your BTC email management webpage. *It is your responsibility to log in to your BTC email account, set up any forwarding features you would like, and to check your email account daily to receive these important messages.*

The library staff at BTC provide technical support for all school-related IT (Information Technology) needs. If you are experiencing trouble with your email account, with password management, or any other network-based technology necessary for your learning at BTC, the library staff are well-trained and helpful in this regard.

**Your readiness for email use will be assessed by your reply to an email message sent to you by your instructor. Replying to this email message with an email message of your own is a mastery-level objective for every new student in this lab exercise.**

When you graduate from this program and enter the workforce, your BTC email account will remain active for some time, but not in perpetuity. Therefore, you must inform your instructors of your preferred email account for post-graduation correspondence before you leave BTC. We use email to regularly communicate job announcements of interest to graduates, so it is in your best interest to remain connected.

[file i02132](#)

## Question 72

In order to learn PLC programming and perform the exercises necessary for exams in this course, you must have your own PLC *trainer* consisting of a working PLC and input switches all wired and ready to use.

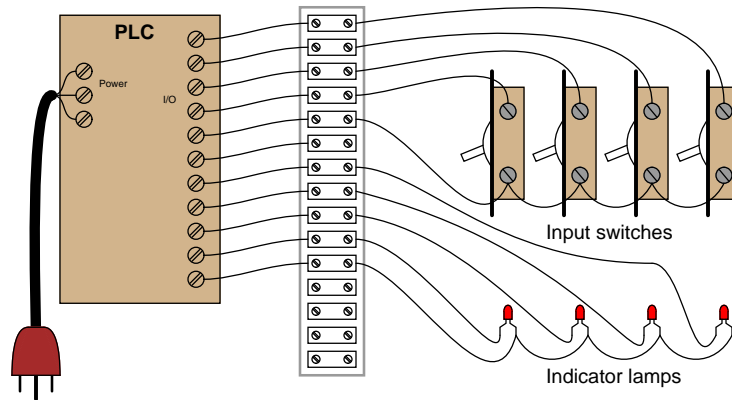

All components should be securely mounted to a wood board or some other structure making it easy to transport and use. You *must* have a terminal block in between the switches, indicators, and PLC I/O terminals to allow for easy connection and disconnection of external devices to your PLC without wearing out the screws on the PLC's terminal block prematurely. Separate terminal blocks are easily replaced, whereas the terminal block on your PLC is likely much more expensive and inconvenient to replace! A photograph of a student-built PLC trainer is shown here as an example:

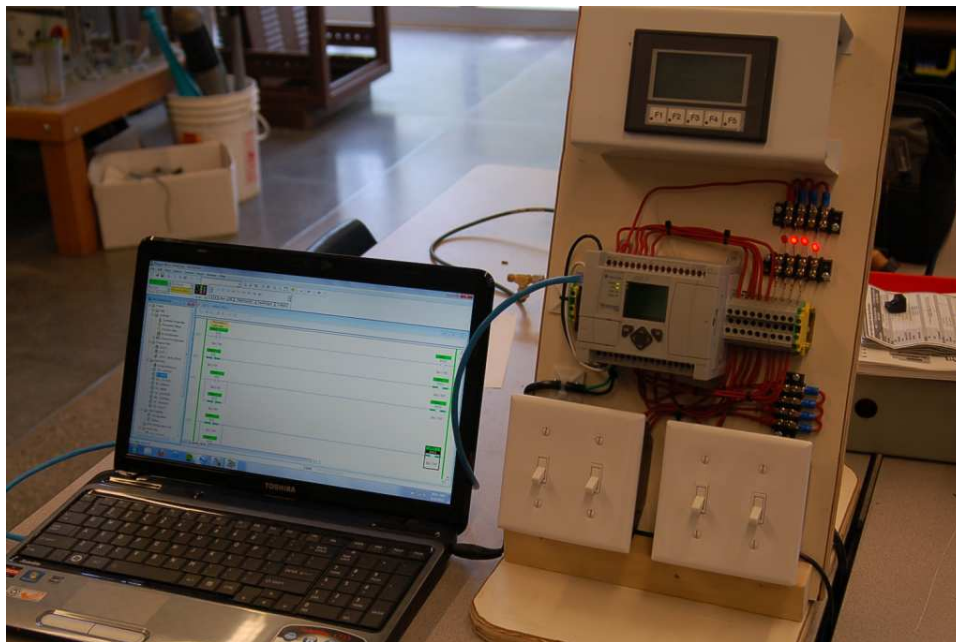

Note the use of terminal blocks for all wiring connections between the PLC and external devices, as well as the use of residential-style light switches for the PLC's inputs.

Consult the user's manual for your PLC in order to determine how all devices should be wired to the input and output (I/O) terminals. Note that often there are different types of I/O (AC, DC, sourcing, sinking) available for the same (or similar) model of PLC. Most PLC user's manuals give detailed diagrams showing how to connect devices to discrete I/O points, so be sure to follow the proper diagram for your specific PLC model!

Once you have your PLC wired, the next step is to install and run the software used to program your programmable logic controller (PLC), and try to get the two devices communicating with each other. This, of course, requires you have a special cable connecting your PC to your PLC, with any necessary “drivers” installed on your PC to allow it to communicate. Like all serial-based communications, the PC needs to be properly configured with regard to bit rate, number of data bits, number of stop bits, and parity in order to communicate with the PLC. The software you will be using should have an “auto detect” feature which will sequentially try various combinations of these parameters until it finds one combination that works. Note: on Allen-Bradley PLCs, you must first install and run software called *RSLinx* which manages communications between your PC and PLC, before you start up the programming software (*RSLogix*).

After that, your next step is to use programming software (installed in a personal computer) to program your PLC with some simple function consisting of “contact” and “coil” instructions. The purpose of a virtual contact in a PLC program is to *read* data bits from memory, while the purpose of a virtual coil in a PLC program is to *write* data bits to memory. Thus, you will create programs for the PLC using virtual contacts to read the states of real-world switches connected to inputs on the PLC, and using virtual coils to control real-world outputs on the PLC to energize loads such as lamps and solenoids. The interconnections and arrangements of these virtual contacts and coils determine the logic implemented by the PLC: specifying the conditions necessary to energize real-world devices based on input conditions.

You will find step-by-step instructional tutorials for both Allen-Bradley MicroLogix and Koyo CLICK PLCs in your Instrumentation Reference (provided by the instructor). Follow these tutorials to establish communication between your PC and your PLC, and to write a simple contact-and-coil ladder diagram program, before attempting the exercises that follow. You will also find much pertinent information for programming Allen-Bradley MicroLogix PLCs in the *RSLogix 500 Getting Results Guide*, since the SLC 500 line of Allen-Bradley PLCs program so similarly to the MicroLogix line.

This example shows an Allen-Bradley MicroLogix 1000 series PLC (model 1761-L10BWA) wired to two toggle switches and one LED indicator lamp, complete with a demonstration program. Note that line power (120 VAC) wire connections to power the PLC have been omitted, so the focus is solely on the I/O wiring:

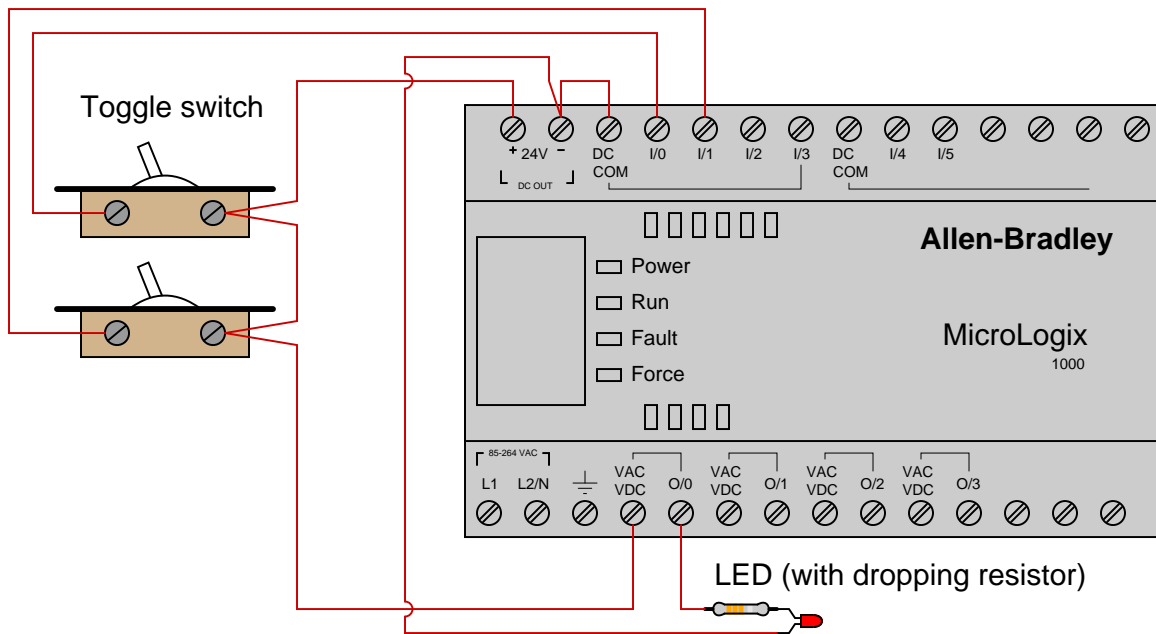

*Ladder-Diagram program written to PLC:*

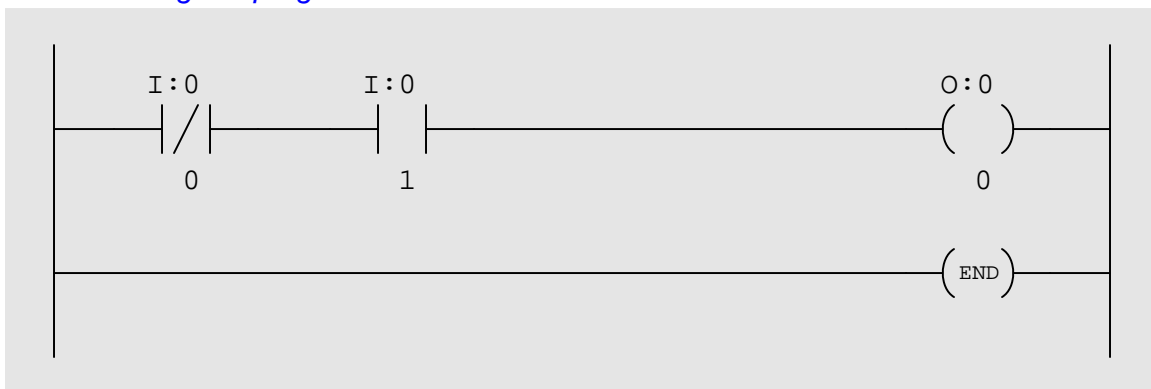

Note how Allen-Bradley I/O is labeled in the program: input bits designated by the letter **I** and output bits designated by the letter **O**.

Based on the wiring and program you see for this PLC, identify the switch state combinations resulting in an energized lamp. Try duplicating this program in your own PLC (even if it is a different brand or model) and see how it functions. Be sure to activate the *color highlighting* feature of your programming editor so you may see the “live” status of the program’s virtual contacts and coil!

This example shows a Siemens S7-200 series PLC (model 224XP) wired to two toggle switches and one LED indicator lamp, complete with a demonstration program:

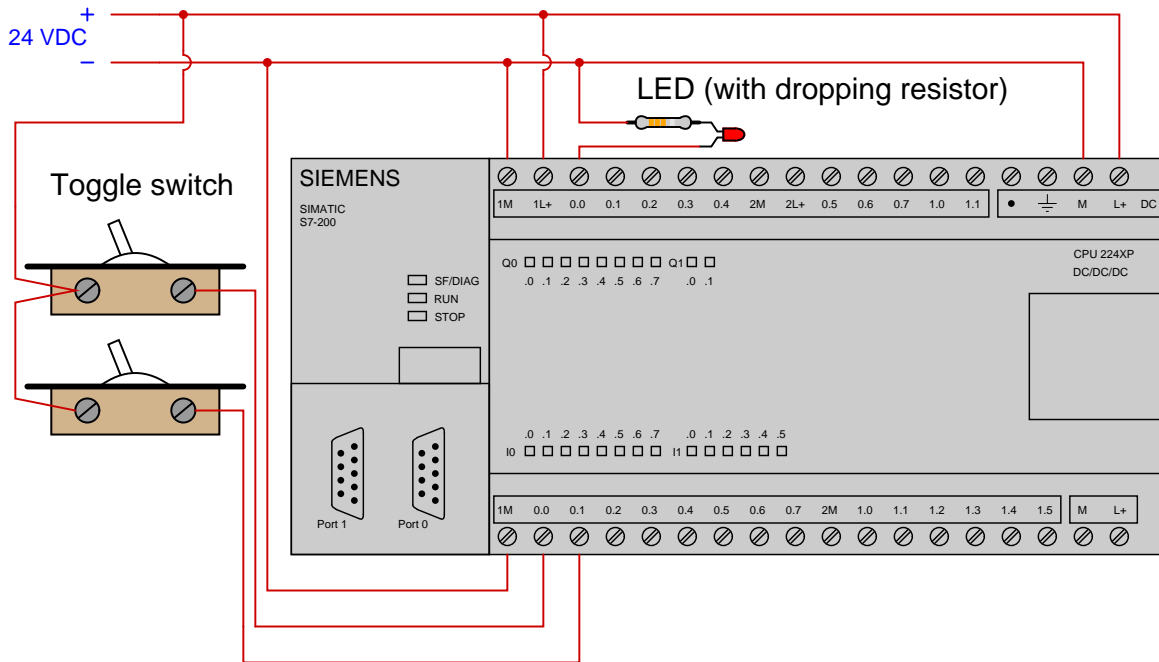

*Ladder-Diagram program written to PLC:*

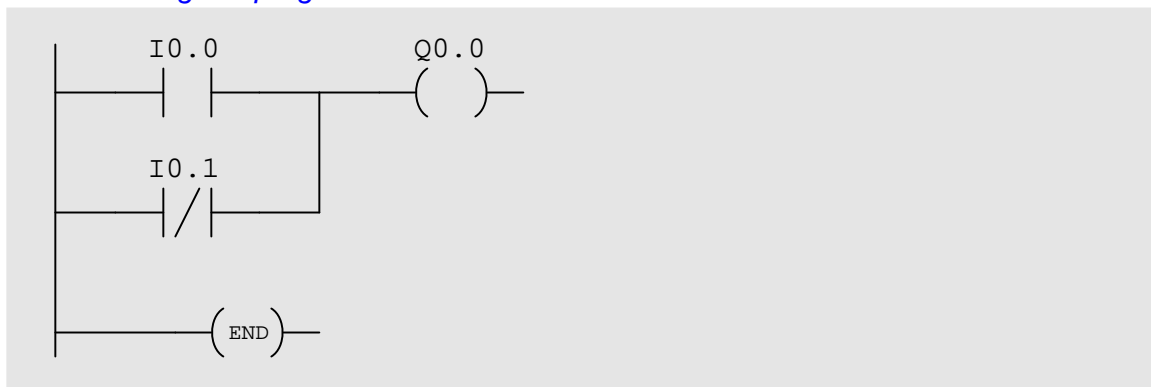

Note how Siemens I/O is labeled in the program: input bits designated by the letter I and output bits designated by the letter Q.

Based on the wiring and program you see for this PLC, identify the switch state combinations resulting in an energized lamp. Try duplicating this program in your own PLC (even if it is a different brand or model) and see how it functions. Be sure to activate the *color highlighting* feature of your programming editor so you may see the “live” status of the program’s virtual contacts and coil!

This example shows a Koyo “CLICK” PLC (model C0-02DD1-D) wired to two toggle switches and one LED indicator lamp, complete with a demonstration program:

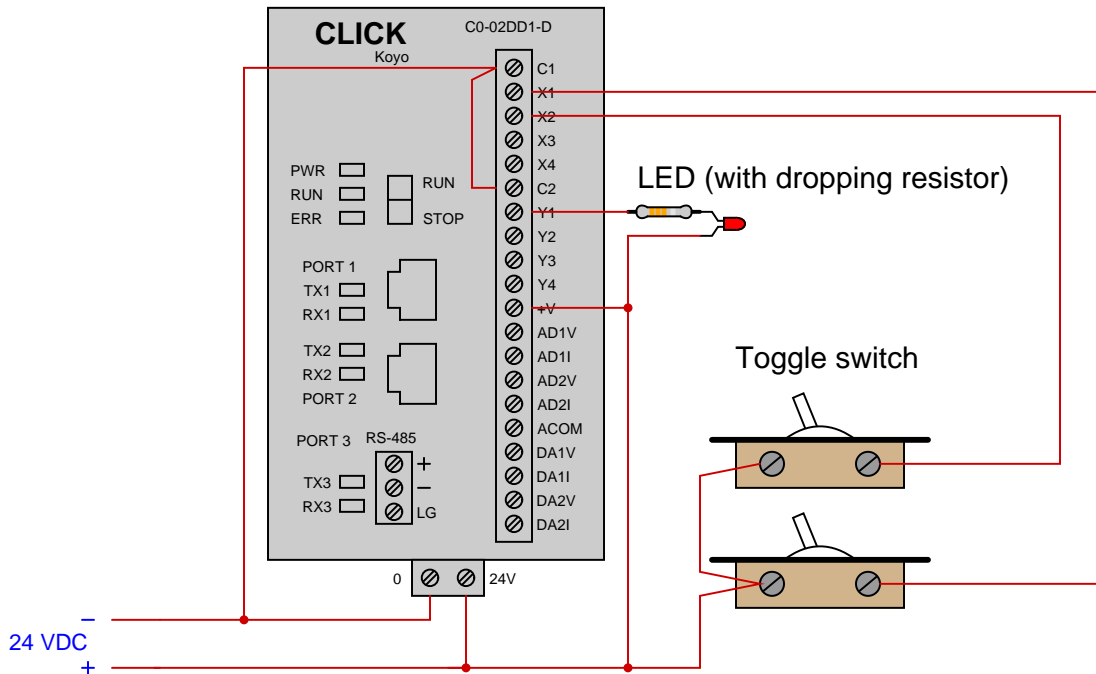

*Ladder-Diagram program written to PLC:*

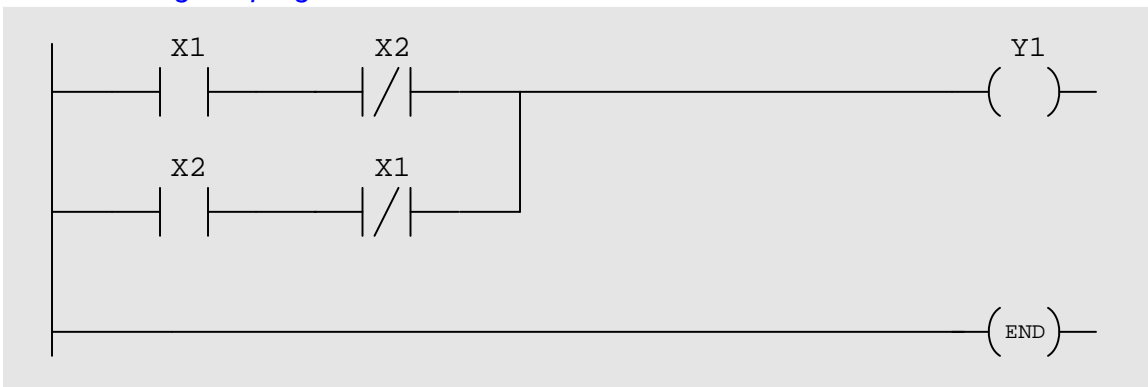

Note how Koyo I/O is labeled in the program: input bits designated by the letter X and output bits designated by the letter Y.

Based on the wiring and program you see for this PLC, identify the switch state combinations resulting in an energized lamp. Try duplicating this program in your own PLC (even if it is a different brand or model) and see how it functions. Be sure to activate the *color highlighting* feature of your programming editor so you may see the “live” status of the program’s virtual contacts and coil!

[file i04513](#)



## Answers

---

Answer 1

---

Answer 2

---

Answer 3

---

Answer 4

---

Answer 5

---

Answer 6

- PSL = Pressure Switch, Low
- PSH = Pressure Switch, High
- PSHH = Pressure Switch, High-High

Both warning lamps should be off when the steam pressure is between 80 and 200 PSI. The boiler will automatically shut down when the shutdown solenoid de-energizes, and this will happen if the steam pressure exceeds 220 PSI for at least 10 seconds.

The difference between a “normally open” process switch and a “normally closed” process switch is vitally important for technicians to understand. The “normal” condition referred to in each label does *not* mean the condition that is typical for the process. Rather, it refers to a condition where the switch is subjected to *minimum stimulus*. In other words, the “normal” condition for each switch is:

- Temperature switch = cold
- Pressure switch = low or no pressure
- Level switch = empty vessel
- Flow switch = low or no flow

---

Answer 7

**Partial answer:**

- Identify the meaning of the square boxes (each one with a unique number inside) – **these are terminals in a terminal block or terminal strip assembly**
- Identify the meaning of the numbers near each side of the relay contacts – **these are terminal numbers on the relay base (the socket the relay plugs into)**
- Identify whether the pressure switch enables the solenoid to energize under if the sensed pressure *exceeds* the trip point or *falls below* the trip point – **the solenoid energizes when the applied pressure rises above (exceeds) the trip point**

Here is a photograph of Hand-Off-Auto switches used to control industrial fan motors:



---

Answer 8

Be sure to review the operation of this simple motor start-stop circuit in your answer!

---

Answer 9

---

Answer 10

Answer 11

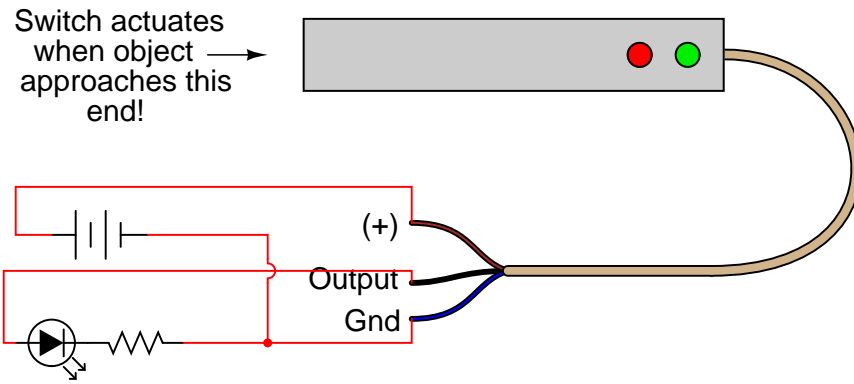

Answer 12

The “normal” condition for a process switch is the condition of *least stimulus*. For example:

- A pressure switch will be in its “normal” state when there is *minimum pressure applied*
- A level switch will be in its “normal” state when there is *no level detected by the switch*
- A temperature switch will be in its “normal” state when it is *cold*
- A flow switch will be in its “normal” state when there is *no flow detected by the switch*

Answer 13

*Light bulb turns off when limit switch actuates*

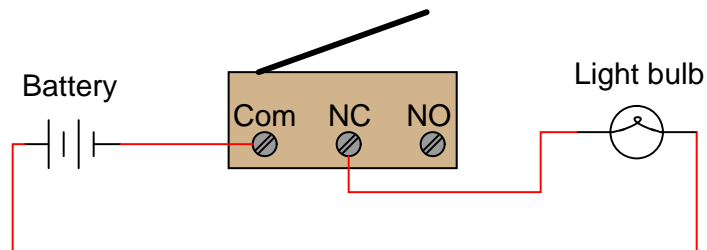

---

Answer 14

As with all process switches, the “normal” status refers to the electrical status of the switch in a condition of *minimum stimulus*. In this particular case, when the process pressure is below the set value, the switch will be in its “normal” status (as drawn in the schematic), with electrical continuity between Com and NC, and no electrical continuity between Com and NO.

It is very important to distinguish the “normal” status of a process switch from its “typical” status while installed in a working process. For instance, if this switch’s set value was 50 PSI, we could use it as a low pressure alarm (PAL) switch, whose duty it is to energize an alarm if the process pressure ever drops *below* 50 PSI. In this case, the alarm circuit would use the Com and NC contacts on the switch, with regular process pressure (above 50 PSI) holding the normally-closed contact in its *open* state, letting that contact fall back to its “normal” (closed) state if the process pressure ever drops below 50 PSI. Here, the NC contact *typically* resides in the open state, even though it is a “normally closed” contact, simply because of how we are using it in the process.

Some students may balk at this convention. “Why not call the contact either ‘normally-open’ or ‘normally-closed’ depending on which state that contact *normally* resides while operating in the process?” they may ask. The answer is simple: the switch manufacturer has no idea how you intend to use it. How would they know whether to call the contact NO or NC, if they don’t know the “normal” operating conditions of your process and the purpose for which you will use their switch? The standard convention of defining “normal” switch contact status as that state in a condition of minimum stimulus (low pressure for a pressure switch, low temperature for a temperature switch, etc.), while potentially confusing, is actually less confusing than the alternative most students immediately envision.

---

Answer 15

The lamp’s illumination signifies a condition where the compressed air pressure is somewhere between 85 and 115 PSI. The lamp will turn off if the pressure drops below 85 PSI *or* if the pressure rises above 115 PSI.

---

Answer 16

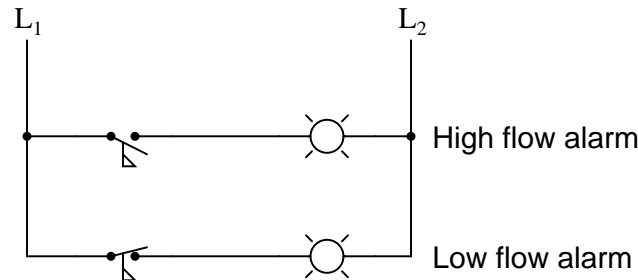

Answer 17

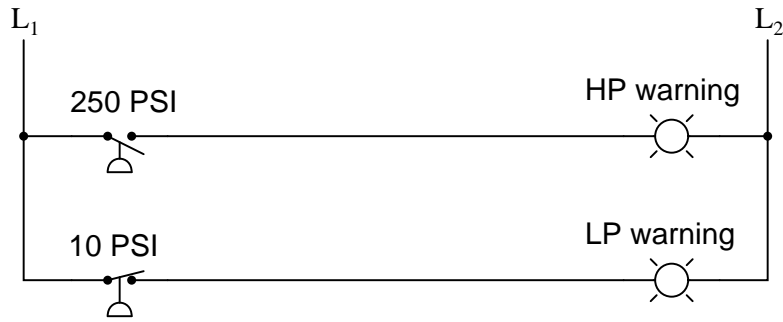

Answer 18

When the pressure switch contact opens, the relay de-energizes, closing the normally-closed relay contact and turning the light on.

This circuit functions as a *high-pressure* alarm, turning the light bulb on if the process pressure ever rises above switch's trip value.

Answer 19

There are two viable ways to connect the “remote” pushbutton switches to this electric actuator.

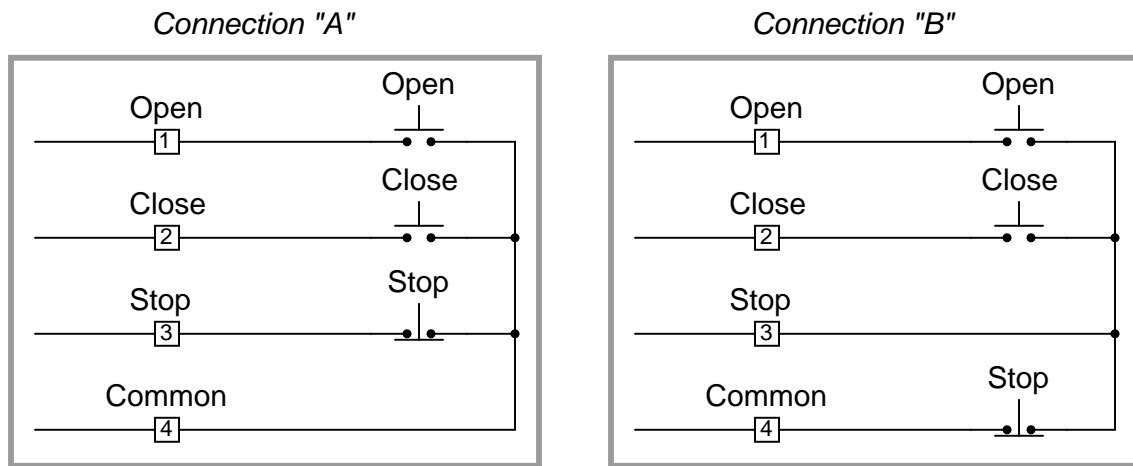

A good exercise in circuit analysis is to determine how the operation of these two connection schemes will differ.

Answer 20

**Partial answer:** (this is just one possible solution to the wiring of the pressure switch):

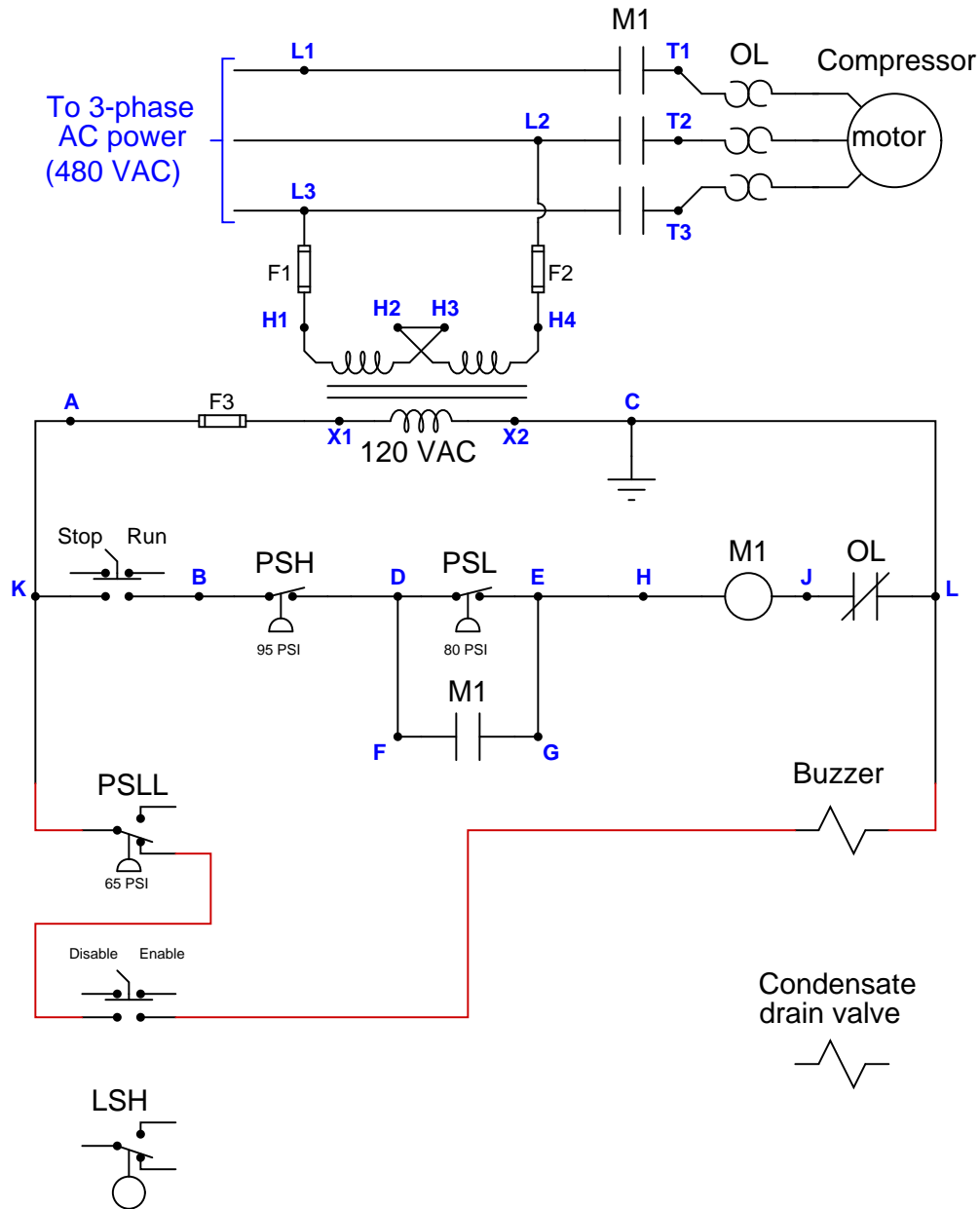

Answer 21

The “Start” contactor must be energized first, then at a later time is de-energized as the “Run” contactor is simultaneously energized. Either timing relays or a PLC handles this sequencing of contactors.

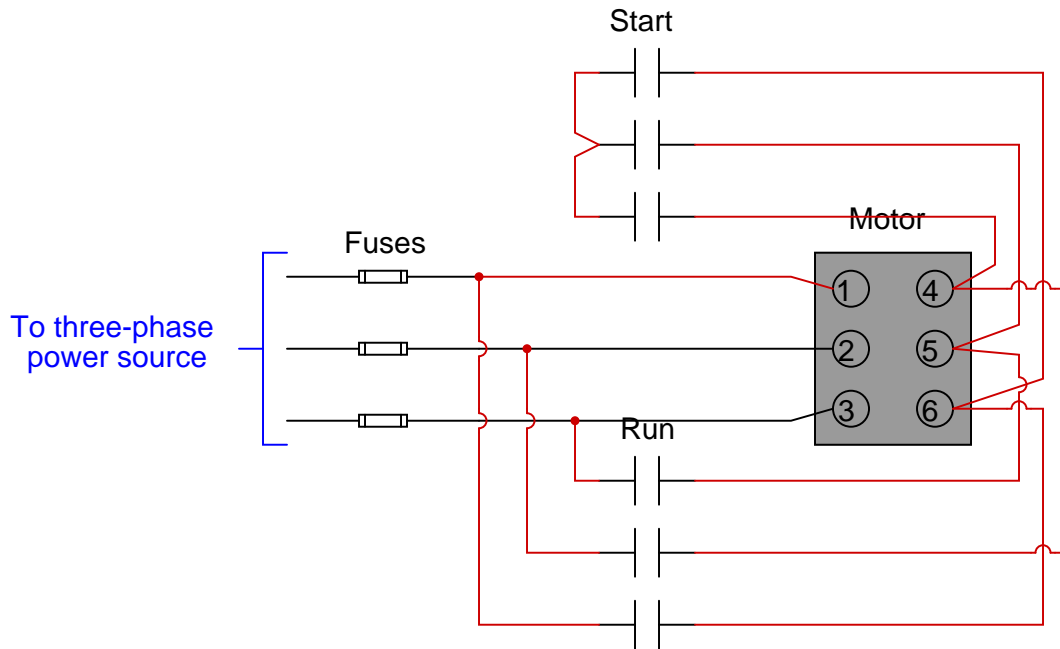

---

Answer 23

---

Answer 24

---

Answer 25

If you have access to an AC induction motor and some batteries, feel free to experiment with DC injection braking in the class or lab! All you need to do is connect a source of low-voltage DC to the stator winding(s) of an AC induction motor, and you will be able to feel the braking effect as you try to spin the motor's shaft with your fingers!

---

Answer 26

---

Answer 27

Note: the *Service Factor* (SF) on an electric motor's nameplate specifies the degree to which the motor may be overloaded on an intermittent basis. For this particular motor, the service factor is equal to 1.15, which means it will be able to output 1.15 times its nameplate horsepower ( $300 \text{ HP} \times 1.15 = 345 \text{ HP}$ ). Under this amount of overload, it will draw 477 Amperes of current rather than its 100% rating of 427 Amperes. The fact that the *Service Factor Amps* rating does not equal 1.15 times the full-load *Amps* rating tells us this motor's power factor is not constant between these two operating conditions.

---

Answer 28

---

Answer 29

---

Answer 30

---

Answer 31

---

Answer 32

In the start-up mode, the motor's rotor winding is short-circuited by the "Start" contact. This makes the motor behave like a normal squirrel-cage induction motor with its rotor bars and shorting rings.

As soon as the speed switch detects adequate rotor speed, the "Start" coil de-energizes and the "Run" coil energizes, connecting the rotor winding directly to a DC power source to magnetize it and lock it into synchronous mode.

---

Answer 33

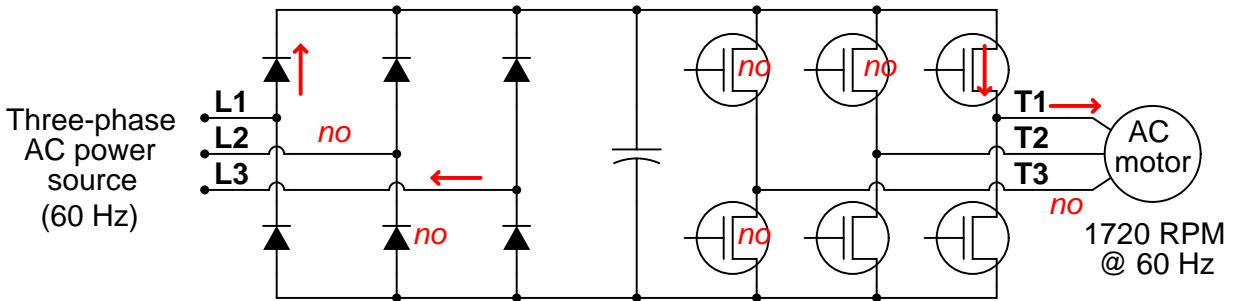

Speed  $\approx$  860 RPM



Answer 34

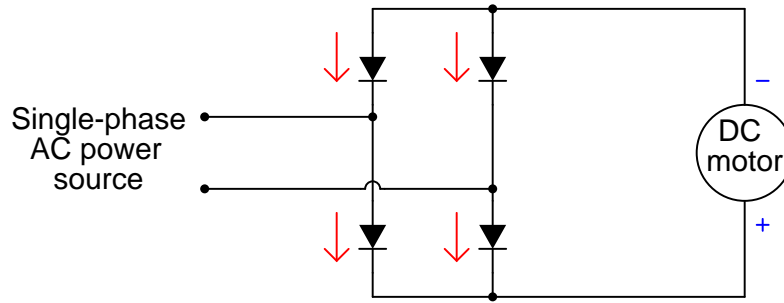

*Arrows drawn in the direction of conventional flow notation*

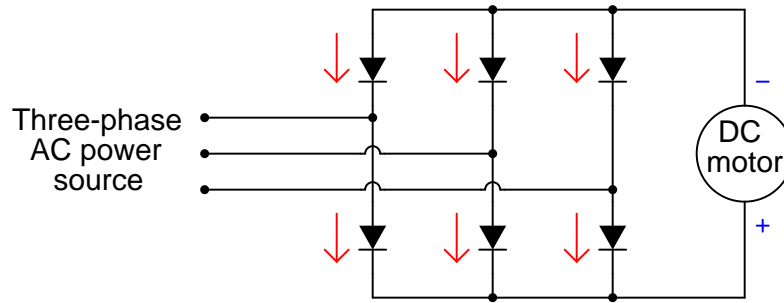

*Arrows drawn in the direction of conventional flow notation*

Answer 35

Answer 36

Answer 37

These components *will indeed* resonate, at 180 Hz. This is a problem because 180 Hz is the 3rd harmonic of a 60 Hz AC power system, and we expect significant odd-harmonic frequencies to come from an operating VFD!

Answer 38

The braking energy here will be dissipated in a braking resistor connected to the VFD.

---

Answer 39

Fault	Possible	Impossible
High level switch failed open		✓
Low level switch failed open		✓
Broken wire between <b>D</b> and M1 coil		✓
Contactorauxiliary contact failed open	✓	
480 volt fuse(s) blown		✓
Contactormain contact(s) failed open		✓
Broken wire between <b>B</b> and <b>G</b>	✓	
Thermal overload unit tripped		✓
Low level switch failed shorted		✓
Transformer secondary winding failed open		✓

---

Answer 40

Time period	$Q_1$	$Q_2$	$Q_3$	$Q_4$	$Q_5$	$Q_6$
$t_1 - t_2$	ON	off	off	ON	ON	off
$t_2 - t_3$	off	ON	off	ON	ON	off
$t_3 - t_4$	off	ON	ON	off	ON	off
$t_4 - t_5$	off	ON	ON	off	off	ON
$t_5 - t_6$	ON	off	ON	off	off	ON
$t_6 - t_7$	ON	off	off	ON	off	ON

If PWM is being used to modulate the output into a quasi-sine wave, then the “ON” states shown in the table do not necessarily represent *full, continuous on* states within the specified timeframes, but rather series of on/off pulses. The “off” states shown in the table, however, do indeed represent *full, continuous off* states within each specified timeframe.

To be more precise in my answer, the table should look like this:

Time period	$Q_1$	$Q_2$	$Q_3$	$Q_4$	$Q_5$	$Q_6$
$t_1 - t_2$	pulse	off	off	pulse	pulse	off
$t_2 - t_3$	off	pulse	off	pulse	pulse	off
$t_3 - t_4$	off	pulse	pulse	off	pulse	off
$t_4 - t_5$	off	pulse	pulse	off	off	pulse
$t_5 - t_6$	pulse	off	pulse	off	off	pulse
$t_6 - t_7$	pulse	off	off	pulse	off	pulse

---

Answer 41

---

Answer 42

---

Answer 43

---

Answer 44

**Partial answer:**

The line voltage at the generator bus is given to us by the alternator rating of 4160 volts. Unless otherwise specified, the voltage or current rating of a three-phase device is always a *line* quantity.

---

Answer 45

Here are *some* possibilities:

- Fuse #3 blown open
- One winding failed open inside the motor (assuming a “Y” winding configuration)

There are additional fault possibilities here, as well as several valid “next steps” you could take from this point. Discuss alternatives with your classmates.

---

Answer 46

---

Answer 47

The way this circuit is presently wired, the lower LED will always be on regardless of proximity switch status.

---

Answer 48

**Partial answer:**

<b>Fault</b>	<b>Possible</b>	<b>Impossible</b>
High level switch failed open		
Low level switch failed open		✓
Broken wire between <b>D</b> and M1 coil		✓
Contactors auxiliary contact failed open		
Contactors auxiliary contact failed shorted		
Contactors main contact(s) failed open		✓
Broken wire between <b>B</b> and <b>G</b>		✓
Thermal overload unit tripped		
High level switch failed shorted		
Transformer secondary winding failed open		

---

**Answer 49**

Here is a comprehensive list of faults, each one individually capable of accounting for the symptom (no light) and the measurement of 24 volts between **C** and **D**:

- Lamp burned out (failed open)
- Wire failed open between **A** and **C**
- Wire failed open between **B** and **D**

Based on this short list of possible faults – assuming only *one* of them is actually true – the value of each proposed test is as follows:

<b>Diagnostic test</b>	<b>Yes</b>	<b>No</b>
Measure $V_{CF}$		✓
Measure $V_{ED}$		✓
Measure $V_{AB}$	✓	
Measure $V_{AD}$	✓	
Measure $V_{CB}$	✓	
Measure $V_{EF}$		✓
Measure current through wire connecting <b>A</b> and <b>C</b>		✓
Jumper <b>A</b> and <b>C</b> together	✓	
Jumper <b>B</b> and <b>D</b> together	✓	
Jumper <b>A</b> and <b>B</b> together		✓

A good rule to apply when evaluating proposed tests is to ask the question: “Will this test give me the exact same result no matter which one of the possible faults is true?” If so, the test is useless. If not (i.e. the results would differ depending on which of the possible faults was true), then the test has value because it will help narrow the field of possibilities.

---

**Answer 50**

You may locate the `grades_template` on the Y: network drive at BTC, provided you log in to the computer system using your individual student ID and password (not a generic login such as “btc”). It is also available for download at the *Socratic Instrumentation* website.

---

**Answer 51**

The rotating magnetic field from a three-phase motor stator assembly will exert a torque on *any* conductive object. The magnetic properties of the object within the field are largely irrelevant. The only reason iron is placed in the rotor is to eliminate what would otherwise be a huge air gap between the stator poles, thereby strengthening the stator’s magnetic field for heightened effect. This stronger magnetic field then acts upon the aluminum “squirrel cage” bars to produce more torque than would otherwise be possible.

---

Answer 52

The concept to bear in mind here is that overload heaters function to protect the motor by serving as thermal models of the motor. As such, they must carry current at all times the motor is carrying current, in order to heat up and cool down along with the motor.

With *two* overload heater assemblies in this circuit (one for each direction), only one of these OL heater assemblies will heat at any given time the motor is running. If the motor switches direction, current will now pass through the “cold” heater while the “warm” heater cools off, despite the fact the motor itself continues to remain warm from use.

If the motor is run hard in one direction, then reversed, the “cold” overload heater assembly will not accurately reflect the pre-heated status of the motor. This may lead to a condition of overload, where the motor is allowed to heat up too much because the too-cold OL heaters haven’t been heating as long as the motor has.

---

Answer 53

In a properly designed system, with L2 grounded at the power source, this fault will result in a blown fuse when the pressure switch closes. In a circuit with L1 and L2 reversed, this same ground fault would energize the relief solenoid, with or without the pressure switch’s “permission.”

Follow-up question: explain how a test instrument called a *megger* could be used to detect the presence of a ground fault.

---

Answer 54

The “Start” function is latching, whereas the “Jog” function is not. A common application of this concept is in a kitchen blender, where one button starts (and latches) the blender, while another simply “pulses” the blender.

---

Answer 55

- “Stop” pushbutton switch fails open: *Motor cannot start, lamp never energizes.*
- Relay contact CR1-1 fails open: *Motor starts and lamp energizes when “Start” button is pressed, but both immediately de-energize when it is released.*
- Relay contact CR1-2 fails open: *“Motor run” lamp turns on and off as expected, but the motor itself never runs.*
- Relay coil CR1 fails open: *Motor cannot start, but the lamp energizes when the “Start” pushbutton is pressed.*

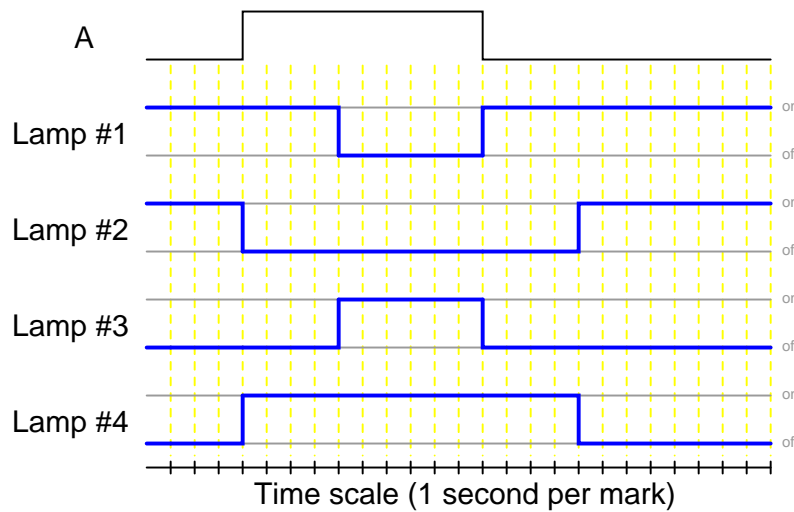
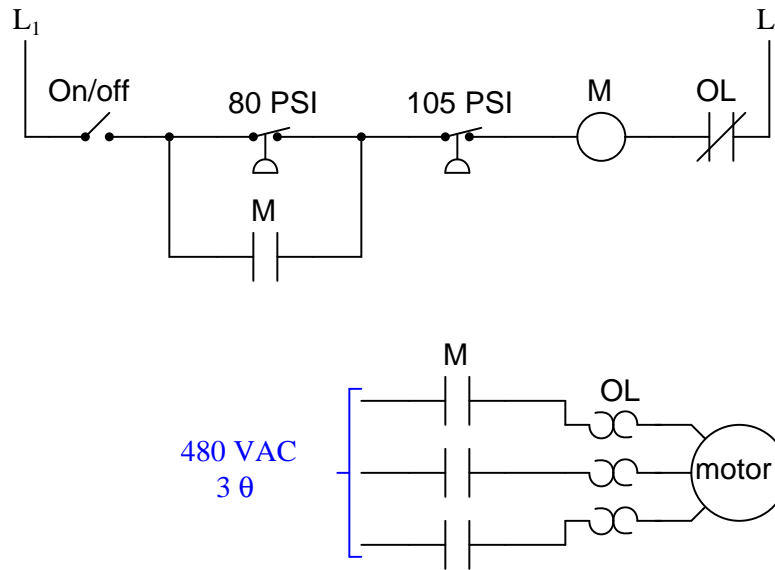

Each contact with an arrowhead pointed *toward* the energized position is an **on-delay** contact, whereas each contact with an arrowhead pointed *away* from the energized position (i.e. toward the “normal” state) is an **off-delay** contact.

Time-delay relays are not the easiest for some students to understand. The purpose of this question is to introduce students to the four basic types of time-delay relay contacts and their respective behaviors. Discuss with your students how the contact symbols make sense (arrows on the switch actuators describing direction of delay).

Note to your students how it is possible to have different types of time-delay contacts actuated by the same relay coil.

---

Answer 58

The siren immediately activates when the “Start” pushbutton is pressed, and then cuts out 5 seconds later when the motor actually starts.

---

Answer 59

The normally-open and normally-closed “M” contacts provide seal-in and interlock functions, respectively. The time-delay relays prevent the motor from being *immediately* reversed.

---

Answer 60

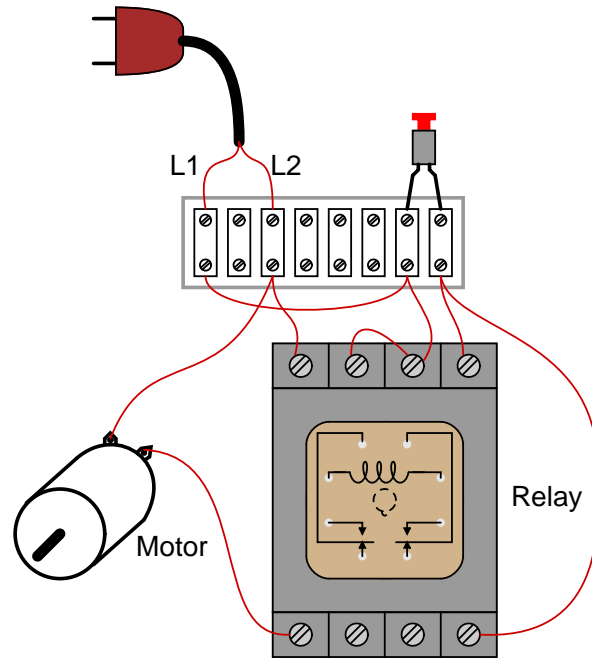

---

Answer 61

This is a graded question – no answers or hints given!

---

Answer 62

This is a graded question – no answers or hints given!

---

Answer 63

This is a graded question – no answers or hints given!

---

Answer 64

This is a graded question – no answers or hints given!

---

Answer 65

This is a graded question – no answers or hints given!

---

Answer 66

This is a graded question – no answers or hints given!

---

---

Answer 67

This is a graded question – no answers or hints given!

---

Answer 68

This is a graded question – no answers or hints given!

---

Answer 69

This is a graded question – no answers or hints given!

---

Answer 70

This is a graded question – no answers or hints given!

---

Answer 71

---

Answer 72

For the Allen-Bradley MicroLogix example, the lamp will energize only when switch 0 is turned off and switch 1 is turned on.

For the Siemens S7-200 example, the lamp will energize when switch 0 is turned on or if switch 1 is turned off, or both conditions occur simultaneously.

For the Koyo example, the lamp will energize according to the *Exclusive-OR* function with switch 1 and switch 2. The lamp energizes when switch 1 is on and switch 2 is off, or when switch 1 is off and switch 2 is on.