

MASSACHUSETTS INSTITUTE OF TECHNOLOGY

# APOLLO

## GUIDANCE AND NAVIGATION

FACILITY FORM 602

265 15604  
(ACCESSION NUMBER) \_\_\_\_\_ (THRU) \_\_\_\_\_

22  
(PAGES) \_\_\_\_\_ (CODE) \_\_\_\_\_

\_\_\_\_\_  
(NASA CR OR TMX OR AD NUMBER) \_\_\_\_\_ (CATEGORY) 2/

(NASA-CR-154578) ON OPTIMAL STEERING TO  
ACHIEVE REQUIRED VELOCITY (Massachusetts  
Inst. of Tech.) 23 P

N78-70049

00/12 Unclas 33765



**MIT** INSTRUMENTATION  
CAMBRIDGE 39, MASSACHUSETTS LABORATORY

~~AVAILABLE TO NASA HEADQUARTERS ONLY~~



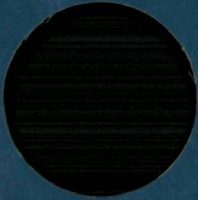

**CASE FILE COPY**



# APOLLO

## GUIDANCE AND NAVIGATION

Approved: Milton B. Trageser Date: 4/30/65  
MILTON B. TRAGESER, DIRECTOR  
APOLLO GUIDANCE AND NAVIGATION PROGRAM

Approved: Roger B. Woodbury Date: 4/30/65  
ROGER B. WOODBURY, DEPUTY DIRECTOR  
INSTRUMENTATION LABORATORY

R-491

ON OPTIMAL STEERING TO  
ACHIEVE "REQUIRED VELOCITY"

by

Balraj G. Sockappa

April 1965

**MIT** INSTRUMENTATION  
LABORATORY

CAMBRIDGE 39, MASSACHUSETTS

COPY # 139

## ACKNOWLEDGEMENT

The author wishes to acknowledge the many helpful discussions with James Potter, Edward M. Copps and Fredrick H. Martin and especially the latter for his invaluable assistance with numerical examples. Ref. 2 contains a thorough analysis of steering laws of the form of Eq (7).

This report was prepared under DSR Project 55-238, sponsored by the Manned Spacecraft Center of the National Aeronautics and Space Administration through Contract NAS 9-4065.

The publication of this report does not constitute approval by the National Aeronautics and Space Administration of the findings or the conclusions contained therein. It is published only for the exchange and stimulation of ideas.

## ON OPTIMUM STEERING TO ACHIEVE "REQUIRED VELOCITY"

## ABSTRACT

A well-known method of on-board guidance of space vehicles is based on the concept of a "required velocity". The dynamics of the powered-flight phase of the vehicle can be written in terms of a velocity-to-be-gained as

$$\dot{\underline{v}}_g = - [C^*] \underline{v}_g - \underline{a}$$

where

$$\underline{v}_g = \underline{v}_r - \underline{v}$$

$$[C] = \left[ \begin{array}{c} \frac{\partial \underline{v}}{\partial \underline{r}} \\ \frac{\partial \underline{r}}{\partial \underline{r}} \end{array} \right]$$

and  $\underline{a}$  is the thrust acceleration,  $\underline{v}_r$  is the required velocity.

In general  $[C^*]$  is a function of position  $\underline{r}$  and hence time-varying. With reasonable approximations this equation can be considered equivalent to the familiar "state equation"

$$\dot{\underline{x}} = [A] \underline{x} + \underline{u}$$

of a dynamic system.

In this paper the necessary condition, that must be satisfied by a fuel optimum guidance law, is developed for a system where  $[A]$  is linear and time-invariant and  $[\underline{u}]$  is a known function of time. From this condition, with first order approximations, an explicit guidance law is derived. Some conclusions, that have been

previously obtained by other methods, are extracted from the solution.

Numerical examples are included to indicate the performance of this law in comparison to other familiar steering laws. The near optimum law is shown to yield excellent results in practical problems in which the assumptions of time-invariance and linearity are not quite true. The results are compared with optimum solutions obtained with the calculus of variations.

Computational aspects of the implementation of the law are discussed. The mathematical form of this law is shown to result in some computational simplifications.

by Balraj G. Sockappa  
April 1965

## ON OPTIMUM STEERING TO ACHIEVE "REQUIRED VELOCITY"

Introduction

The speed and weight (rather, the lightness) of digital space computers have reached a stage where real time computation of very sophisticated explicit guidance laws has become practical. Not only the rapid repetitive solution of guidance equations but the generation of suitable commands, based on the solution, to control the thrust direction is possible. Consequently, guidance laws that result in improved fuel economy and which can be implemented for on-board computation have received considerable attention recently.

In this paper the optimality of a certain type of steering, referred to as the "required velocity steering" is discussed. A time-optimal solution is derived on the basis of a constant linear system. With first-order approximations, a steering law that is practical to implement is derived. The performance of this law is compared, in numerical examples, with other methods of steering that are presently used in this class of problems. The steering law is applied to a translunar injection problem. The result is seen to be extremely good, though the assumptions used in the derivation are not quite valid for this problem. Some conclusions, that are already well established by other methods, are also extracted.

Required Velocity Steering

The solution to a major class of guidance problems is based on the well-known concept<sup>1</sup> of "required velocity ( $\underline{v}_r$ )", which is defined as that velocity which the vehicle should possess at the present position ( $\underline{r}$ ) and time ( $t$ ) in order to achieve the desired objective. Most single impulse transfers would fall in this category.

Based on  $\underline{v}_r$ , a velocity-to-be-gained ( $\underline{v}_g$ ) is defined as

$$\underline{v}_g = \underline{v}_r - \underline{v} \quad (1)$$

where

$\underline{v}$  is the present velocity.

It can be shown that  $\dot{\underline{v}}_g$  satisfies the differential equation

$$\frac{d\underline{v}_g}{dt} = \dot{\underline{v}}_g = -\underline{C}^* \underline{v}_g - \underline{a} \quad (2)^\#$$

where the matrix  $\underline{C}^* = \frac{\partial \underline{v}_r}{\partial \underline{r}}$

and  $\underline{a}$  is the acceleration due to thrust.

It can also be shown that

$$\begin{aligned} -\underline{C}^* \underline{v}_g &= \dot{\underline{v}}_r - \underline{g} \\ &= \underline{b} \end{aligned} \quad (3)$$

where  $\underline{g}$  is the acceleration due to gravity.

The aim of the powered flight maneuver is to impart to the vehicle the velocity  $\underline{v}_g$  so that, at the cut-off point, the vehicle has the corresponding required velocity. Hence, the steering law can be considered as a control law designed to null the vector  $\underline{v}_g$  with the control effort  $\underline{a}$  according to Eq (2).

An immediately evident way of achieving this is to point the thrust such that

$$\underline{a} * \underline{v}_g = 0 \quad (4)^{\#\#}$$

In most practical cases this law is found to result in more burning time and consequently costs more fuel than another law designed to hold  $\underline{v}_g$  irrotational. This law can be written as

$$\dot{\underline{v}}_g * \underline{v}_g = 0 \quad (5)$$

or from Eqs (2) and (3),

$$(\underline{b} - \underline{a}) * \underline{v}_g = 0 \quad (6)$$

This steering law has been found to give excellent performance in many cases.<sup>2</sup> Actually, both Eqs (4) and (5) can be written in a more general form as

$$\underline{a} * \underline{v}_g = c \underline{b} * \underline{v}_g \quad (7)$$

where  $c$  is a scalar.

$\dot{x}$  indicates time derivative of  $x$

$\underline{x} * \underline{y}$  indicates the cross product of  $x$  and  $y$



In most cases, near fuel-optimal performance can be achieved by the proper choice of  $c$ . This method has been exhaustively investigated elsewhere<sup>2</sup>.

In the following sections, a fuel-optimal policy will be developed, based on a system whose  $C^*$  matrix is constant and linear. The results are extended for application to practical problems.

### Linear Time-Invariant System

Consider a three-dimensional system whose state can be described by the differential equation.

$$\dot{\underline{x}} = A \underline{x} + \underline{u} \quad (8)$$

where

$$\begin{aligned} \underline{x} &\text{ is the state of the system,} \\ A &\text{ is a time-invariant (constant) matrix} \\ \text{and } |\underline{u}| = u &\leq F(t). \end{aligned} \quad (9)$$

A fuel-optimal control drives the state from  $\underline{x}(0)$  to zero in time  $T$  such that

$$J = \int_0^T |\underline{u}| dt \quad (10)$$

is minimized. Introducing a fourth variable  $x_0$  we can write<sup>3</sup>

$$\begin{pmatrix} \dot{x}_0 \\ \dot{\underline{x}} \end{pmatrix} = \begin{pmatrix} 0 & 0^T \\ 0 & A \end{pmatrix} \begin{pmatrix} x_0 \\ \underline{x} \end{pmatrix} + \begin{pmatrix} u \\ \underline{u} \end{pmatrix} \quad (11)^\#$$

or

$$\dot{\underline{y}} = B \underline{y} + \underline{\alpha} \quad (12)$$

where

$$\underline{\alpha} = \begin{pmatrix} \alpha_0 \\ \alpha_0 \alpha_1 \\ \alpha_0 \alpha_2 \\ \alpha_0 \alpha_3 \end{pmatrix}, \quad \alpha_0 = u \quad (13)$$

---

<sup>#</sup>Superscript T indicates "transpose"

$$\text{and } \alpha_i = \frac{u_i}{\alpha_0} \text{ for } i = 1, 2, 3$$

The adjoint to Eq (12) is given by

$$\dot{\underline{p}} = - B^T \underline{p} \quad (14)$$

where

$$B^T = \left\| \begin{array}{cc} 0 & \underline{0}^T \\ \underline{0} & A^T \end{array} \right\| \quad (15)^\#$$

Using Pontryagin's Maximum Principle it can be verified<sup>3</sup> that

$$(p_1 \alpha_1 + p_2 \alpha_2 + p_3 \alpha_3 + p_4) \alpha_0 \quad (16)$$

should be maximum for optimum control. Now choose  $p$  so that

$$\underline{p} = \begin{pmatrix} p_0 \\ \underline{p} \end{pmatrix} \quad (17)$$

Eq (13) can be written as

$$\underline{\alpha} = \begin{pmatrix} \alpha_0 \\ \underline{u} \end{pmatrix} \quad (18)$$

From Eqs (9), (10) and (11),

$$J = x_0(T) \quad (19)$$

Therefore

$$p_0(T) = -1 \quad (20)$$

Further, since

$$\dot{p}_0(t) = 0,$$

$$p_0(t) = -1 \quad (21)$$

---

<sup>#</sup> $\underline{0}$  is the null vector

Hence from expression (16)

$$(\rho^T \frac{\underline{u}}{|\underline{u}|} - 1) \quad (22)$$

should be maximized for optimal control.

Therefore

$$\alpha_0 = |\underline{u}| = \begin{cases} F(t) & \text{if } |\underline{\rho}| > 1 \\ 0 & \text{if } |\underline{\rho}| < 1 \end{cases} \quad (23)$$

$$\text{and } \frac{\underline{u}}{|\underline{u}|} = \frac{\underline{\rho}}{|\underline{\rho}|}$$

Eq (23) indicates that  $\underline{u}$  should be pointed along  $\underline{\rho}$  so that

$$\underline{\rho} = k \underline{u} \quad (24)$$

where  $k$  is a scalar.

Since, from Eqs (14), (15), and (17),

$$\dot{\underline{\rho}} = -A^T \underline{\rho} \quad (25)$$

$$\frac{d}{dt} (k \underline{u}) = -A^T k \underline{u} \quad (26)$$

or

$$\dot{k} \underline{u} + k \dot{\underline{u}} = -A^T k \underline{u} \quad (27)$$

or

$$\dot{\underline{u}} = -(A^T + s I) \underline{u} \quad (28)^{\#}$$

where

$$s(t) = \frac{\dot{k}}{k} \text{ is a scalar} \quad (29)$$

Since  $A$  is time-invariant and  $A^T$  and  $sI$  commute with each other the solution to the differential equation (28) is

$$\underline{u}(t) = e^{-A^T (t-t_1)} e^{-\int_{t_1}^t I s dt} \underline{u}(t_1) \quad (30)$$

<sup>#</sup> $I$  is the identity matrix



## The Guidance Problem

Comparison of Eq (2) with Eq (8) indicates that the required velocity guidance problem is very similar to the system we have considered, with

$$\begin{aligned}\underline{x} &= \underline{v}_g \\ A &= -C^*\end{aligned}\quad (31)$$

$$\text{and} \quad \underline{u} = -\underline{a}$$

Assume that  $C^*$  can be considered linear and time invariant<sup>2</sup>. Then for fuel-optimal control, from Eqs (28) and (31)

$$\dot{\underline{a}} = (C^{*T} - sI)\underline{a}\quad (32)$$

Hence

$$\underline{a}(\sigma) = e^{C^{*T}(\sigma-t)} e^{-\int_t^\sigma I s(t) dt} \underline{a}(t)\quad (33)$$

Now let T be the total time of burning so that from Eq (2)

$$\underline{v}_g(T) = 0 = e^{-C^*(T-t)} \underline{v}_g(t) + \int_t^T e^{-C^*(T-\sigma)} \underline{a}(\sigma) d\sigma\quad (34)$$

Substitution of Eq (33) yields

$$0 = e^{-C^*(T-t)} \underline{v}_g(t) + \int_t^T e^{-C^*(T-\sigma)} e^{C^{*T}(\sigma-t)} e^{-\int_t^\sigma sI dt} \underline{a}(t) d\sigma\quad (35)$$

Making a change of variable in Eq (35) according to

$$\sigma = t + z\quad (36)$$

yields

$$0 = e^{-C^*(T-t)} \underline{v}_g(t) + \int_0^{T-t} e^{-C^*(T-t-z)} e^{C^{*T}z} e^{g(z)I} \underline{a}(t) dz\quad (37)$$

$$0 = e^{-C^*(T-t)} \underline{v}_g(t) + e^{-C^*(T-t)} \int_0^{T-g} e^{C^*z} e^{C^{*T}z} e^{g(z)I} \underline{a}(t) dz \quad (38)$$

where

$$g(z) = - \int_t^{t+z} s(t) dt \quad (39)$$

and

$$T_g = T - t \text{ is the time to cut-off.} \quad (40)$$

Rearrangement of Eq (38) yields

$$\underline{v}_g(t) = \int_0^{T-g} e^{C^*z} e^{(C^{*T}z + gI)} \underline{a}(t) dz \quad (41)$$

At this point it is interesting to observe that if  $C^*$  is skew-symmetric (norm-invariant system),  $C^*$  and  $C^{*T}$  commute and hence

$$e^{C^*z} e^{C^{*T}z} = I$$

Equation (38) can then be integrated to yield

$$\underline{a}(t) = - \underline{k}_1 \underline{v}_g(t)$$

a well-known<sup>4</sup> fuel-optimal control law.

## Practical Implementation

The optimal policy for thrust acceleration  $\underline{a}(t)$  should satisfy Eq (41). In order to find  $\underline{a}(t)$  explicitly in terms of  $\underline{v}_g$  the integral in Eq (41) has to be evaluated. In general, the integral is difficult to evaluate exactly. However, if the special features of the problem at hand are used to simplify the integrand, a very useful form for  $\underline{a}(t)$  results:

Eq (32) can be rearranged as

$$s \underline{a} = C^{*T} \underline{a} - \dot{\underline{a}}$$

or

$$s \underline{a}^T \underline{a} = \underline{a}^T C^{*T} \underline{a} - \underline{a}^T \dot{\underline{a}} \quad (42)$$

Hence

$$s = \frac{\underline{a}^T C^{*T} \underline{a}}{|\underline{a}|^2} - \frac{\underline{a}^T \dot{\underline{a}}}{|\underline{a}|} \quad (43)$$

$$= \frac{\underline{a}^T C^{*T} \underline{a}}{|\underline{a}|^2} - \frac{d}{dt} \frac{|\underline{a}|}{|\underline{a}|} \quad (44)$$

Substituting Eq (23) into Eq (44) yields

$$s = \frac{\underline{a}^T C^{*T} \underline{a}}{|\underline{a}|^2} - \frac{\dot{F}(t)}{F(t)} \quad (45)$$

Now from Eq (39) we can write

$$g(z) = - \int_t^{t+z} \frac{\underline{a}^T C^{*T} \underline{a}(t)}{|\underline{a}|^2} dt + \int_{F(t)}^{F(t+z)} \frac{1}{F} dF \quad (46)$$

The first term is usually a slow varying quantity. Further, in repetitive computation its value is continuously updated, so that it can be treated as a constant, yielding

$$g(z) = -k_t z + \log \frac{F(t+z)}{F(t)} \quad (47)$$



Substitution of Eq (47) into Eq (41) yields

$$-\underline{v}_g(t) = \int_0^T e^{C^* z} e^{C^{*T} z} e^{-k_t z + \log \frac{F(t+z)}{F(t)}} I \underline{a}(t) dz \quad (48)$$

For chemical rockets

$$F(t) = \frac{F(0)}{1 - t/\tau} \quad (49)$$

Hence

$$g(z) = -k_t z + \log \frac{1 - t/\tau}{1 - \frac{(t+z)}{\tau}} \quad (50)$$

Substitution of Eq (50) into Eq (48) yields

$$-\underline{v}_g(t) = \frac{\tau}{\tau - t} \int_0^T e^{C^* z} e^{C^{*T} z} e^{-I k_t z} e^{-I \log \left(1 - \frac{t+z}{\tau}\right)} \underline{a}(t) dz \quad (51)$$

In most practical problems higher powers of matrix  $[C^* T_g]$  can be ignored compared to the identity matrix I. We can expand the integral in Eq. (51) yielding, to a first-order approximation,

$$\begin{aligned} & \int_0^T e^{C^* z} e^{C^{*T} z} e^{-I k_t z} e^{-I \log \left(1 - \frac{t+z}{\tau}\right)} \underline{a}(t) dz \\ & \approx \int_0^T \left[ I + (C^* + C^{*T} - k_t) z \right] \left(1 - \frac{t+z}{\tau}\right)^{-1} \underline{a}(t) dz \quad (53) \end{aligned}$$

In the Appendix (Eq. A-3) it is shown that

$$\int_0^{T_g} \left[ I + (C^* + C^{*T} - k_t) z \right] \left( 1 - \frac{t+z}{T} \right)^{-1} \underline{a}(t) dz$$

$$\cong T_g s_1 \left[ I + \left( \frac{C^* + C^{*T}}{2} \right) T_g s_2 \right] \underline{a}(t) \quad (54)$$

where  $s_1$  and  $s_2$  are scalar factors given by Eq. (A-4) through (A-7).

Substitution of Eq. (54) into Eq. (51) yields

$$\underline{a}(t) \cong k_2 \left[ I + s_2 T_g \left( \frac{C^* + C^{*T}}{2} \right) \right]^{-1} \underline{v}_g \quad (55)$$

where  $k_2$  is a scalar whose value is immaterial since we are only interested in the direction of  $\underline{a}(t)$ .

The above equation indicates that when  $C^*$  is not symmetric, the skew-symmetric part should be ignored (since  $C^*$  can be written as the sum of symmetric and skew-symmetric matrices). This conclusion has been arrived at previously by a different approach<sup>2</sup>.

The implementation of Eq (55) for real-time computation is shown in the form of a block diagram of Fig. 1. Some of the numerical operations in this form, such as the matrix inversion, are rather time consuming for on-board computation. An approximation for the inverse operation yields

$$\underline{a}(t) = k_3 \left[ I - s_2 (C^* + C^{*T}) \frac{T_g}{2} \right] \underline{v}_g(t) \quad (56)$$

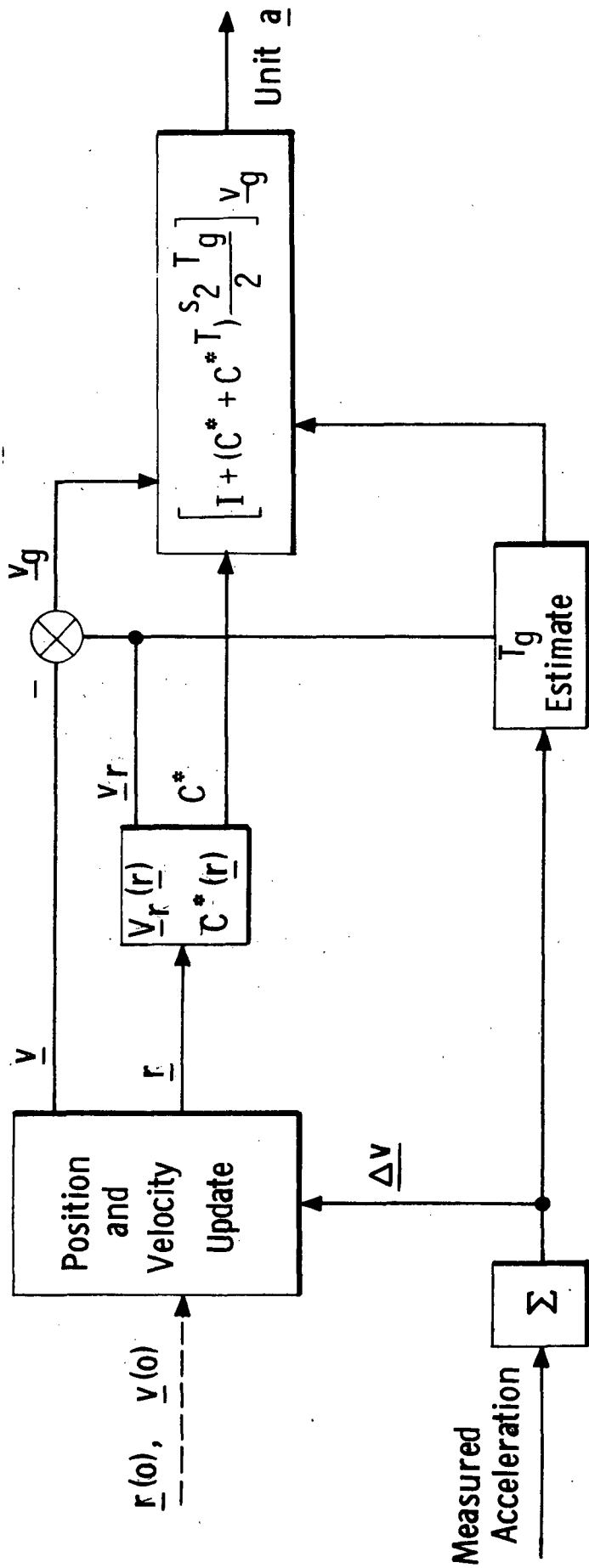

Fig. 1  
Computation with  $C^*$  matrix.



In problems where  $C^*$  is symmetric (a case that covers most required-velocity guidance problems<sup>2</sup>), Eq (56) reduces (by Eq (3)) to

$$\underline{a}(t) = k_3 \left[ \underline{v}_g + \underline{b} s_2 T_g \right] \quad (57)$$

Further, since usually  $k_t T_g \ll 1$ ,  $s_2 \cong 1$  according to Eq (A-5). Hence Eq (57) can be written as

$$\underline{a}(t) = k_3 (\underline{v}_g + \underline{b} T_g) \quad (58)$$

This steering law is very easy to implement as shown in Fig. 2. A good estimation of  $T_g$  is not an easy matter. However, even such a simple approximation as

$$T_g = \frac{|\underline{v}_g|}{|\underline{a}|} \quad (59)$$

gives good results as shown in the numerical examples that follow. If the optimum burning time is previously known,  $T_g$  can be readily computed according to Eq (40).

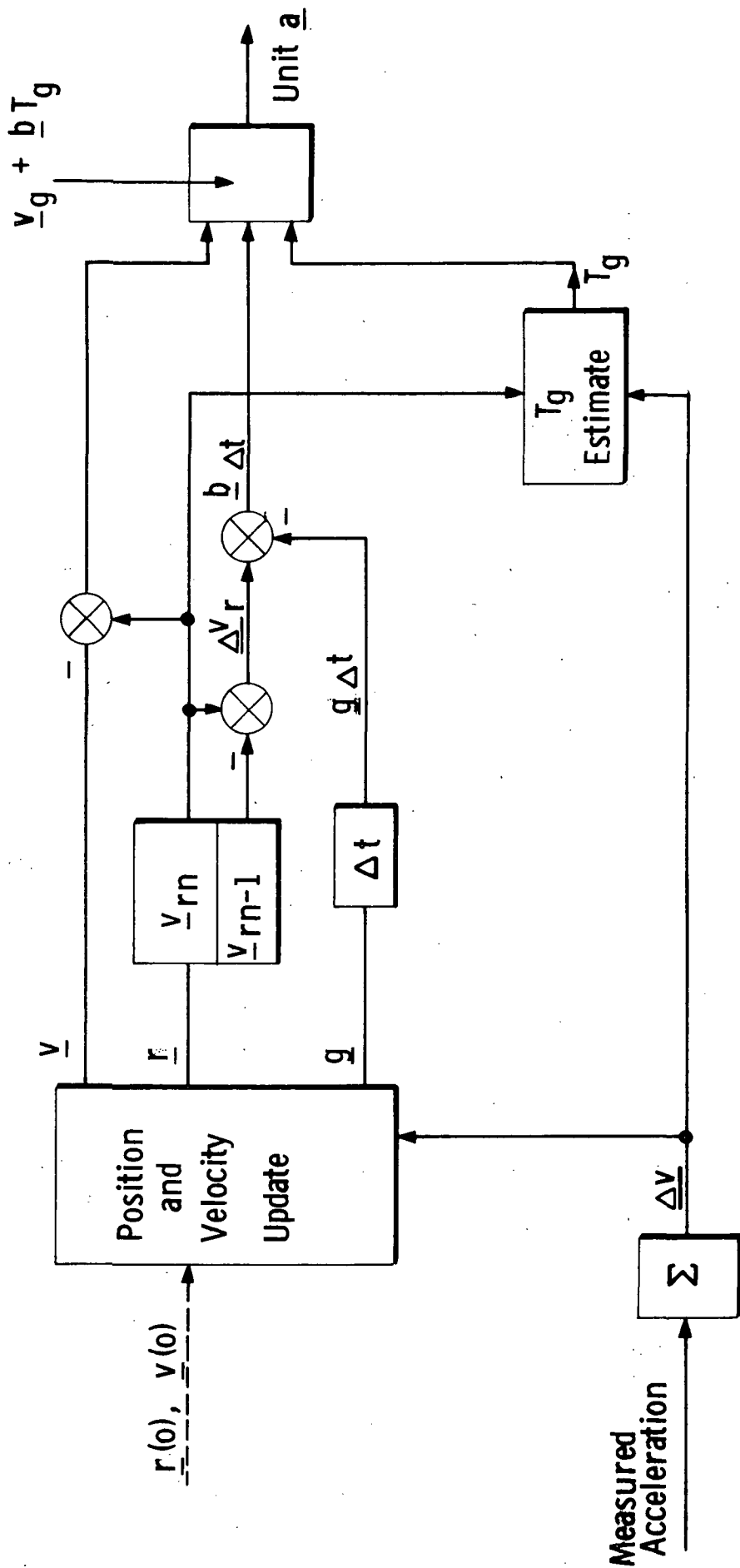

Fig. 2

Computation with  $\underline{b}$  vector.

## Numerical Examples

### I Constant Time-Invariant System

Consider a two dimensional system with

$$C^* = \begin{vmatrix} -2.469 \times 10^{-4} & -2.7317 \times 10^{-4} \\ -7.7317 \times 10^{-4} & -2.9653 \times 10^{-4} \end{vmatrix} \frac{1}{\text{sec}}$$

$$F(0) = 12.5 \text{ lbs}$$

$$\tau = 1000 \text{ sec}$$

$$v_g(0) = \underline{x}(0) = \begin{pmatrix} -1.7164 \times 10^4 \\ 1.9175 \times 10^4 \end{pmatrix} \frac{\text{ft}}{\text{sec}}$$

The time and fuel  $\Delta v$  required to drive  $\underline{x}$  to the origin is tabulated below for the different steering laws. The optimum was obtained by the methods of the calculus of variations

|                     | Optimum  | $v_g \times \dot{v}_g$ | Eq (58)  | Eq (56)  |
|---------------------|----------|------------------------|----------|----------|
| Time (sec)          | 834.38   | 837.36                 | 834.67   | 834.54   |
| $\Delta v$ (ft/sec) | 22476.44 | 22702.86               | 22497.96 | 22487.98 |

### II A Translunar Injection

The steering laws of Eq (5) and Eq (58) were used on a typical translunar injection problem. A vehicle of initial mass 8000 slugs is to be injected from an earth orbit of 100 n. miles to pass through an inertial point of radius  $1.8 \times 10^5$  n. miles and 201.25 degrees ahead of ignition point at a specified time. The engine has an initial thrust of 56,667 lbs and an exhaust velocity of 12,500 ft/sec.

Steering with Eq (5) took 1028.07 sec and 10,920.64 ft/sec of  $\Delta v$  whereas steering with Eq (58) took only 1021.43 sec

and a  $\Delta v$  of 10808.5 ft/sec.

### Conclusions

The derivation of the steering law was based on several assumptions. They are:

- 1)  $C^*$  is linear and time invariant
- 2) Eigenvalues of  $C^*$  are smaller than  $\frac{1}{T}$
- 3)  $\frac{\underline{a}^T C^{*T} \underline{a}}{|\underline{a}|^2}$  varies slowly with time
- 4) The optimum maneuver consists of a single burn.

The application of this law has resulted in very nearly fuel-optimal steering in systems in which these assumptions are valid. Several numerical examples (not listed here) indicate that the steering law developed here results in better performance than the laws that have been in use so far, even in cases where the assumptions are not valid, (as in example II). The form of the steering law has an advantage in that the direction of  $\underline{a}$  is explicit; whereas in Eq ( 5 ) the direction of  $\underline{a}$  is implicit and consequently a different set of equations are required to pre-align the vehicle.<sup>1</sup> This advantage results in a small decrease in computer storage capacity. Further, it is not always possible to find a solution to satisfy Eq ( 5 ), especially when  $\underline{a}$  is very small. The form of Eq (58) avoids this difficulty.



## Appendix

The integral of Eq (53) can be written as

$$\int_0^{T_g} \left(1 - \frac{t+z}{\tau}\right)^{-1} \left[ I + (C^* + C^{*T} - k_t I) z \right] \underline{a}(t) dz$$

$$= \int_0^{T_g} \left(1 + \frac{t+z}{\tau}\right) \left[ I + (C^* + C^{*T} - k_t I) z \right] \underline{a}(t) dz \quad (A-1)$$

$$= T_g (1 + t/\tau) \left[ I + (C^* + C^{*T} - k_t I) \right] \frac{T_g}{2} \underline{a}(t)$$

$$+ \frac{T_g^2}{\tau} \left[ \frac{I}{2} + (C^* + C^{*T} - k_t I) \frac{T_g}{3} \right] \underline{a}(t)$$

$$= T_g \left\{ I \left[ (1 + t/\tau) + \frac{T_g}{2\tau} \right] + \left[ \frac{C^* + C^{*T} - k_t I}{2} T_g \right] \left[ (1 + t/\tau) + \frac{2 T_g}{3\tau} \right] \right\} \underline{a}(t)$$

$$= T_g s_3 \left[ I \left( 1 - \left( \frac{s_4 k_t T_g}{2} \right) \right) + \frac{C^* + C^{*T}}{2} T_g s_4 \right] \underline{a}(t) \quad (A-2)$$

$$= T_g s_1 \left[ I + \frac{C^* + C^{*T}}{2} T_g s_2 \right] \underline{a}(t) \quad (A-3)$$

where

$$s_1 = s_3 \left( 1 - \frac{s_4 k T}{2 g} \right) \quad (\text{A-4})$$

$$s_2 = s_4 / \left( 1 - \frac{s_4 k T}{2 g} \right) \quad (\text{A-5})$$

$$s_3 = \left( 1 + t/\tau \right) + \frac{T}{2\tau} \quad (\text{A-6})$$

$$s_4 = \left( \left( 1 + t/\tau \right) + \frac{2T}{3\tau} \right) / s_3 \quad (\text{A-7})$$

## References

1. Battin R. H. : Astronautical Guidance, McGraw Hill Book Co., 1964.
2. Frederick H. Martin : A Closed Loop Near Optimal Steering for a Certain Class of Guidance Problems, (To be published)
3. D. F. McAllister, et al: Optimum Steering for Powered Flight Phases of a Lunar Mission, Joint AIAA-AMS-SIAM-DNR Symposium on Control and System Optimization, Monterey, California, Jan 27-29, 1964.
4. M. Athans, P. L. Falb and R. T. Lacoss : Time, Fuel and Energy Optimal Control of Nonlinear Norm Invariant Systems, IEEE Trans on Auto. Control, Vol. AC-8, Number 3, July 1963.

R-491

DISTRIBUTION LIST

Internal

|                       |                        |                        |
|-----------------------|------------------------|------------------------|
| M. Adams              | D. Hoag                | E. Olsson              |
| R. Alonso             | A. Hopkins             | R. Scholten            |
| J. Arnow (Lincoln)    | F. Houston             | E. Schwarm             |
| R. Battin (40)        | L. B. Johnson          | J. Sciegieny           |
| P. Bowditch           | M. Johnston            | N. Sears               |
| R. Boyd               | A. Koso                | J. Shillingford        |
| G. Cherry             | M. Kramer              | W. Shotwell (MIT/ACSP) |
| E. Copps              | A. Laats               | B. Sokkappa (5)        |
| R. Crisp              | A. LaPointe            | W. Stameris            |
| J. Dahlen             | J. Larsen              | J. Stone               |
| E. Duggan             | L. Larson              | J. Suomala             |
| J. Dunbar             | J. Lawrence (MIT/GAEC) | W. Tanner              |
| K. Dunipace (MIT/AMR) | T. J. Lawton           | R. Therrien            |
| R. Euvrard            | T. M. Lawton (MIT/MSC) | W. Toth                |
| J. B. Feldman         | D. Lickly              | M. Trageser            |
| P. Felleman           | G. Mayo                | R. Weatherbee          |
| S. Felix (MIT/S&ID)   | J. McNeil              | R. White               |
| J. Flanders           | R. Mudgett             | L. Wilk                |
| F. Grant              | James Miller           | R. Woodbury            |
| Eldon Hall            | John Miller            | W. Wrigley             |
| D. Hanley             | J. Nevins              | Apollo Library (2)     |
| W. Heintz             | J. Nugent              | MIT/IL Library (6)     |
| E. Hickey             |                        |                        |

External

(ref. PP1-64; April 8, 1964)

P. Ebersole (NASA/MSC) (2)  
W. Rhine (NASA/RASPO) (1)  
L. Holdridge (NAA S&ID/MIT) (1)  
T. Heuermann (GAEC/MIT) (1)  
AC Spark Plug (10)  
Kollsman (10)  
Raytheon (10)  
Major W. Delaney (AFSC/MIT) (1)  
NAA RASPO: (1)  
National Aeronautics and Space Administration  
Resident Apollo Spacecraft Program Office  
North American Aviation, Inc.  
Space and Information Systems Division  
12214 Lakewood Boulevard  
Downey, California  
FO: (3)  
National Aeronautics and Space Administration, MSC  
Florida Operations, Box MS  
Cocoa Beach, Florida 32931  
Attn: HB 23/ Technical Document Control Office  
HDQ: (6)  
NASA Headquarters  
600 Independence Ave., SW  
Washington 25, D.C. 20546  
Attn: MAP-2  
AMES: (2)  
National Aeronautics and Space Administration  
Ames Research Center  
Moffet Field, California  
Attn: Library  
LEWIS: (2)  
National Aeronautics and Space Administration  
Lewis Research Center  
Cleveland, Ohio  
Attn: Library  
FRC: (1)  
National Aeronautics and Space Administration  
Flight Research Center  
Edwards AFB, California  
Attn: Research Library  
LRC: (2)  
National Aeronautics and Space Administration  
Langley Research Center  
Langley AFB, Virginia  
Attn: Mr. A. T. Mattson  
GSFC: (2)  
National Aeronautics and Space Administration  
Goddard Space Flight Center  
Greenbelt, Maryland  
Attn: Manned Flight Support Office Code 512

MSFC: (2)  
National Aeronautics and Space Administration  
George C. Marshall Space Flight Center  
Huntsville, Alabama  
Attn: R-SA  
ERC: (1)  
National Aeronautics and Space Administration  
Electronics Research Center  
575 Technology Square  
Cambridge, Massachusetts  
Attn: R. Hayes/A. Colella  
GAEC: (1)  
Grumman Aircraft Engineering Corporation  
Bethpage, Long Island, New York  
Attn: Mr. A. Whitaker  
NAA: (1)  
North American Aviation, Inc.  
Space and Information Systems Division  
12214 Lakewood Boulevard  
Downey, California  
Attention: Apollo Data Requirements AE99  
Dept. 41-096-704  
GAEC RASPO: (1)  
National Aeronautics and Space Administration  
Resident Apollo Spacecraft Program Officer  
Grumman Aircraft Engineering Corporation  
Bethpage, Long Island, New York  
ACSP RASPO: (1)  
National Aeronautics and Space Administration  
Resident Apollo Spacecraft Program Officer  
Dept. 32-31  
AC Spark Plug Division of General Motors  
Milwaukee 1, Wisconsin  
Attn: Mr. W. Swingle  
WSMR: (2)  
National Aeronautics and Space Administration  
Post Office Drawer MM  
Las Cruces, New Mexico  
Attn: BW 44  
MSC: (45)  
National Aeronautics and Space Administration  
Manned Spacecraft Center  
Apollo Document Control Group  
Houston 1, Texas 77058  
Mr. H. Peterson (1)  
Bureau of Naval Weapons  
c/o Raytheon Company  
Foundry Avenue  
Waltham, Massachusetts  
Queens Material Quality Section (1)  
c/o Kollsman Instrument Corporation  
Building A 80-08 45th Avenue  
Elmhurst, New York 11373  
Attn: Mr. S. Schwartz  
Mr. H. Anschuetz (1)  
USAF Contract Management District  
AC Spark Plug Division of General Motors  
Milwaukee 1, Wisconsin 53201