

DO NOT REMOVE THIS COPY

~~CONFIDENTIAL~~

DOWNGRADED AT 3 YEAR INTERVALS:
DECLASSIFIED AFTER 12 YEARS
DO NOT DECLASSIFY 5200.10

SINGLE COPY ONLY

APOLLO

GUIDANCE AND NAVIGATION

Approved: Milton B. Trageser Date: 7/15/64
MILTON B. TRAGESER, DIRECTOR
APOLLO GUIDANCE AND NAVIGATION PROGRAM

Approved: Roger B. Woodbury Date: 7/20/64
ROGER B. WOODBURY, DEPUTY DIRECTOR
INSTRUMENTATION LABORATORY

CLASSIFICATION CHANGE

To UNCLASSIFIED

By authority of AS - Pa 1612 Date 12/21/72
Changed by L. Shirley
Classified Document Master Control Station, NASA
Scientific and Technical Information Program

MASSACHUSETTS INSTITUTE OF TECHNOLOGY

E-1142 (Rev. 22)

(UNCLASSIFIED TITLE)

SYSTEM STATUS REPORT

July 15, 1964

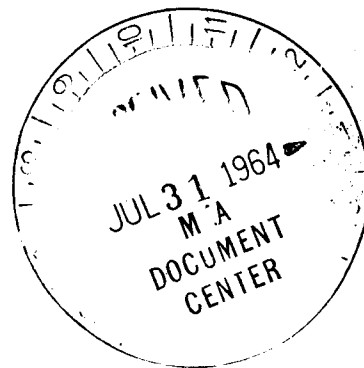

INSTRUMENTATION LABORATORY

CAMBRIDGE 39, MASSACHUSETTS

COPY # 107 OF 153 COPIES
THIS DOCUMENT CONTAINS 42 PAGES

DO NOT REMOVE THIS COPY

~~CONFIDENTIAL~~

ACKNOWLEDGMENT

This report was prepared under DSR Project 55-191, sponsored by the Manned Spacecraft Center of the National Aeronautics and Space Administration through Contract NAS 9-153.

~~This document contains information affecting the national defense of the United States within the meaning of the Espionage Laws, Title 18, U. S. C., Sections 793 and 794, the transmission or the revelation of which in any manner to an unauthorized person is prohibited by law.~~

The publication of this report does not constitute approval by the National Aeronautics and Space Administration of the findings or the conclusions contained therein. It is published only for the exchange and stimulation of ideas.

LIST OF EFFECTIVE PAGES

Page Numbers

Title Page through vi

1-1

2-1 through 2-10

3-1 through 3-7

4-1 through 4-5

5-1 through 5-8

Distribution List

CONTENTS

Section		Page
1	INTRODUCTION	1-1
1-1	INTRODUCTION	1-1
1-2	ACCURACY	1-1
2	BLOCK I COMMAND MODULE DATA	2-1
2-1	WEIGHTS	2-1
2-1.1	WEIGHTS STATUS REPORTING	2-1
2-1.2	CONTROL WEIGHT	2-1
2-1.3	DESIGN LOAD WEIGHT	2-1
2-2	REPORTED WEIGHT CHANGES	2-6
2-2.1	NVB & RESILIENT MOUNTS	2-6
2-2.2	BELLOWS ASSY	2-6
2-2.3	POWER SERVO ASSY	2-6
2-2.4	D&C/AGC (LEB and MP)	2-6
2-3	CENTERS OF GRAVITY	2-6
2-4	MOMENTS OF INERTIA	2-6
2-5	BLOCK I (100-SERIES SYSTEMS)	2-6
2-6	COMMAND MODULE POWER REQUIREMENTS	2-7
3	BLOCK II COMMAND MODULE DATA	3-1
3-1	RELIABILITY	3-1
3-2	WEIGHTS	3-1
3-3	REPORTED WEIGHT CHANGES	3-1
3-3.1	BELLOWS ASSY	3-1
3-3.2	D&C/AGC (LEB and MP)	3-1
3-4	BLOCK II WITH DIGITAL STABILIZATION AND CONTROL FUNCTIONS	3-4
3-5	POWER REQUIREMENTS	3-4
3-6	STATUS OF COMMAND MODULE AGC PROGRAMS	3-7
4	LUNAR EXCURSION MODULE DATA	4-1
4-1	RELIABILITY	4-1
4-2	WEIGHTS FOR LEM	4-1
4-3	REPORTED WEIGHT CHANGES	4-3
4-3.1	AGC DISPLAY AND CONTROLS	4-3
4-4	POWER REQUIREMENTS	4-3
5	GLOSSARY AND SYSTEM DEFINITION	5-1

ILLUSTRATIONS

Figure		Page
2-1	Electrical Load on Primary +28 VDC Power Supply	2-8
3-1	Electrical Load on Primary +28 VDC Power Supply	3-5
4-1	Electrical Load on Primary +28 VDC Power Supply	4-4

TABLES

Table		Page
2-I	Current Weight Status of Block I Command Module	2-2
2-II	Block I Command Module Center of Gravity and Moments of Inertia Data	2-4
2-III	Nominal Power Dissipation (watts) vs G&N Activity	2-9
2-IV	Block I Command Module Power Profile for 14-Day Lunar Orbit Mission	2-10
3-I	Reliability (as of 7/15/64)	3-1
3-II	Current Weight Status of Block II Command Module	3-2
3-III	Block II Command Module Power Profile for 14-Day Lunar Orbit Mission	3-6
3-IV	Current Memory Estimates and the Status of Command Module AGC Programs	3-7
4-I	Reliability (as of 7/15/64)	4-1
4-II	Estimated Weights of LEM G&N Components	4-2
4-III	LEM Power Profile Based on LEM ICD LIS-390-3	4-5

ABSTRACT

The System Status Report is distributed monthly on the 15th. This month's revision of E-1142 (Rev. 22) contains, in general, the following information for the Block I and Block II Command Module and LEM equipment configurations: weights, centers of gravity, moments of inertia, power requirements, status of computer programs, and reliability figures.

Section 1

INTRODUCTION

1-1 INTRODUCTION

The definition of what constitutes Block I and Block II Command Module and LEM hardware is contained in the Glossary, section 5 of this report.

The following information is included in this month's report:

- (1) Command Module, Block I: weights, centers of gravity, moments of inertia, power requirements, and a brief description of Block I 100-series systems.
- (2) Command Module, Block II: weights, power requirements, status of computer programs, and reliability figures.
- (3) LEM: weights, power requirements, and reliability figures.

1-2 ACCURACY

The accuracy of numerical values reported in this revision should not be considered to be within the tolerances implied by the significant figures quoted. The reported values, although based upon the most current information, are subject to normal changes as design and development phases approach completion.

BLOCK I COMMAND MODULE

Section 2

BLOCK I COMMAND MODULE DATA

2-1 WEIGHTS

Table 2-1 presents the weights of all Block I equipment, grouped according to specific location within the Command Module. Weights are reported to the component level and to the nearest tenth of a pound.

Given component weights are identified as estimated, calculated, and measured in the order of increasing accuracy. These terms are defined by North American Aviation as follows.

Estimated weights (E) are based on rough calculations. Calculated weights (C) are based on detailed calculations made from final production drawings that will be used to build flyable equipment. Measured weights (M) are the actual weights of equipment built to the production drawings.

North American Aviation will provide and be responsible for cold plate weights that are not integral with guidance and navigation equipment.

2-1.1 WEIGHTS STATUS REPORTING. Table 2-I also offers a comparison of present component weight values with those listed in System Status Report, E-1142 (Rev. 21, June 15, 1964. All weight changes are explained in paragraph 2-2.

2-1.2 CONTROL WEIGHT. Column (a) in table 2-I contains the February 15, 1964 weight status of Apollo G&N Equipment. Column (a) adds up to approximately the total control weight specified in letter PG-64-113 (March 6, 1964) from Mr. D. Gilbert, ASPO, to Mr. M. Trageser, MIT/IL.

2-1.3 DESIGN LOAD WEIGHT. At NASA Coordination Meeting No. 15A, MIT agreed to assign "not-to-exceed" design load weights for individual Block I G&N subsystems. These weights were assigned by MIT in MIT letter AG 594-64, 18 May 1964, and are shown in column (d) of Table 2-I in this report. The total design load weight represents a secure maximum, since it is unlikely that the largest increases in each subsystem will occur simultaneously. The design loads listed recognize possible individual increases to account for changes accepted by NASA for the Block I flight systems (100-series systems). See paragraph 2-5.

~~CONFIDENTIAL~~
BLOCK I
COMMAND MODULE

Table 2-1. Current Weight Status of Block I Command Module (lbs at 1 g)

Item	Status 2/64 (a)	(b-a)	Status 6/64 (b)	(c-b)	Status 7/64 (c)	Design Load Wt. ** 5/64 (d)
<u>G&N SYSTEMS</u>						
CDU Assy	14.5 (M)	-0.9	13.6 (M)	0.0	13.6 (M)	18.0
Optical Subsystem	14.6 (C)	+1.1	46.2 (M)	0.0	46.2 (M)	100.0
SXT	13.8 (C)		1.6 (M)	0.0	1.6 (M)	
SCT	16.7 (E)	+0.3	2.6 (M)	0.0	2.6 (M)	
Optical Base & Gearing		0.0	25.0 (E)	+0.7	25.7 (M)	
Optical Eyepieces		0.0	13.5 (M)	-0.8	12.7 (M)	
SXT	1.3 (E)	-0.3	60.2 (M)	0.0	60.2 (M)	
SCT	2.3 (E)	+0.3	0.7 (E)	0.0	0.7 (E)	
NVB & Resilient Mounts	25.0 (E)	+0.4	59.8 (C)	-0.7	59.1 (C)	
Bellows Assy	13.5 (M)	-5.2	30.0 (C)	0.0	30.0 (C)	
IMU	60.2 (M)	0.0	8.0 (E)	0.0	8.0 (E)	
Coolant Hoses (two)	1.0 (E)	0.0	70.0 (E)	0.0	70.0 (E)	
Power Servo Assy	59.4 (C)	0.0	3.1 (M)	0.0	3.1 (M)	
G&N Interconnection Assy	35.2 (E)	-0.4				
G&N to S/C Interface Assy	8.0 (E)					
AGC (no spares)	70.0 (E)					
Optical Shroud	3.5 (M)					
<u>LOWER EQUIPMENT BAY</u>						
<u>D&C</u>						
D&C Electronics	2.9 (M)	0.0	2.9 (M)	0.0	2.9 (M)	70.0
Control Electronics	2.9 (E)	-0.9	2.0 (M)	0.0	2.0 (M)	
G&N Ind Cont Panel	9.5 (M)	+0.4	9.9 (M)	0.0	9.9 (M)	
IMU Control Panel	2.4 (M)	+0.2	2.6 (M)	0.0	2.6 (M)	
MDV (includes 1 film)	7.7 (C)	+1.3	9.0 (M)	0.0	9.0 (M)	
D&C/AGC	20.6 (M)	-0.2	20.4 (M)	+1.0	21.4 (C)	
Signal Conditioner Assy	0.0	+4.6	4.6 (E)	0.0	4.6 (E)	
						8.0

~~CONFIDENTIAL~~
BLOCK I
COMMAND MODULE

Table 2-1. Current Weight Status of Block I Command Module (lbs at 1 g) (cont)

Item	Status 2/64 (a)	(b-a)	Status 6/64 (b)	(c-b)	Status 7/64 (c)	Design Load Wt.** 5/64 (d)
<u>MAIN PANEL AREA</u> D&C/AGC	20.5 (M)	-0.1	20.4 (M)	+1.0	21.4 (C)	26.0
<u>LOOSE STORED ITEMS</u>						
Eye Relief Eyepieces	1.5 (E)	0.0	1.5 (E)	0.0	1.5 (E)	3.0
Film Cartridges (4)	2.4 (E)	+0.1	2.5 (M)	0.0	2.5 (M)	5.0
Horizon Photometer	3.6 (E)	-3.6	0.0	0.0	0.0	0.0
Optics Cover	1.7 (M)	-0.1	1.6 (M)	0.0	1.6 (M)	2.5
TOTAL	415.0*	-3.3	411.7	+1.2	412.9	524.0
List of Possible Spares for <u>Block I</u>						
AGC Spare Logic Tray	25.0 (E)	0.0	25.0 (E)	0.0	25.0 (E)	
AGC Spare Memory Tray	34.6 (E)	0.0	34.6 (E)	0.0	34.6 (E)	
PSA Spare (Unique) Modules	16.7 (E)	0.0	16.7 (E)	0.0	16.7 (E)	
CDU Spare	2.5 (E)	0.0	2.5 (E)	0.0	2.5 (E)	
Spare Relay & Diode Module	0.3 (E)	0.0	0.3 (E)	0.0	0.3 (E)	

*Control weight specified in letter PG-64-113 (March 6, 1964) from Mr. D. Gilbert, ASFO, to Mr. Trageser, MIT/IL. See paragraph 2-1.2.

**Design Load Weights are taken from MIT letter AG 594-64 (May 18, 1964). See paragraph 2-1.3.

Table 2-II. Block I Command Module Center of Gravity and Moment of Inertia Data

Item	Weight (lbs)	Centers of Gravity (inches)			Moments of Inertia (lb-in ²)		
		X	Y	Z	Ixx	Iyy	Izz
<u>LOWER EQUIPMENT BAY</u>							
CDU Assy	13.6	63.5	-14.4	35.8	73	144	131
Optical Subsystem							
SXT							
SCT	50.4	69.6	0.5	31.1	1468	992	1737
Opt. Base & Gearing							
Optical Eyepieces							
SXT							
SCT							
IMU	60.2	56.6	0.0	41.7	1186	1450	1438
NVB & Resilient Mounts	25.7*	64.3	-0.1	41.3	3270	4050	5210
Bellows Assy	12.7*						
G&N Interconnection Assy	30.0	53.1	-1.1	46.8	3610	3110	4860
G&N to S/C Interface Assy	8.0	37.8	8.9	44.8	378	403	32
D&C/NAV Station							
IMU Cont Panel	2.6	74.0	-15.4	30.9	15	22	24
D&C Electronics	2.9	49.5	-9.6	39.6	20	22	9
Control Electronics Assy	2.0	63.1	10.7	34.9	9	15	8
Optical Shroud & Cover	4.7	66.8	0.0	28.9	387	108	413
G&N Ind. Control Panel	9.9	54.1	0.1	33.9	455	110	560
D&C/AGC	21.4*	63.5	14.8	36.3	294	1114	780
MDV (Includes 1 film)	9.0	73.5	-4.5	31.0	518	92	531
AGC (no spares)	70.0	37.8	1.3	46.1	4980	3990	1710
PSA	59.1*	45.0	-1.1	41.5	3940	1460	2620
Signal Conditioner Assy	4.6	49.8	9.5	40.5	28	29	14
Coolant Hoses	0.7	64.8	6.5	34.9	7	8	15

(cont)

~~CONFIDENTIAL~~
BLOCK I
COMMAND MODULE

Table 2-II. Block I Command Module Center of Gravity and Moment of Inertia Data(cont)

Item	Weight (lbs)	Centers of Gravity (inches)			Moments of Inertia (lb-in ²)		
		X	Y	Z	Ixx	Iyy	Izz
<u>MAIN PANEL AREA</u> D&C/AGC	21.4*	67.8	-12.5	-20.4	283	256	317
Total Moments of Inertia About the Basic X, Y, Z Axes of the Command Module	408.9*	55.1*	-0.3*	37.3*	681,030	1,939,064	1,308,074
<u>LOOSE STORED ITEMS</u> Eye Relief Eyepieces Film Cartridges (4)	1.5 2.5	(SCT, 4-5/8" x 2 1/2" dia.) (Each cartridge, 1-1/2 x 3 x 6 inches)		1/2" dia. SXT 3" x 2-1/4" dia.)			

* These values represent changes since the last report, Rev. 21, dated June 15, 1964.

BLOCK I COMMAND MODULE

2-2 REPORTED WEIGHT CHANGES

2-2.1 NVB & RESILIENT MOUNTS. The 0.7-pound weight increase is based upon an ACSP "measured weight of parts" list received by MIT/IL on June 17, 1964.

2-2.2 BELLOWS ASSY. The 0.8-pound decrease is also based on the above list (see section 2-2.1).

2-2.3 POWER SERVO ASSY. The 0.7-pound weight decrease results from the elimination of the Backup Mode Electronics.

2-2.4 D&C/AGC (LEB and MP). The addition of 1.0 pound to each of the D&C/AGC's is to account for the weight of the potting compound which was not considered in the original measured weights.

2-3 CENTERS OF GRAVITY

Table 2-II presents the centers of gravity of each weight component or packaged assembly, determined with respect to the basic X, Y, Z axes of the Command Module. Center of gravity values are given to the nearest tenth of an inch.

2-4 MOMENTS OF INERTIA

Table 2-II also presents the moment of the inertia of each weight component or packaged assembly, determined about each of the component axes which (1) run through the center of gravity of the component and (2) are parallel to the basic X, Y, Z axes of the Command Module. The total center of gravity and moments of inertia of all G&N equipment (excluding loose stored items) have been calculated about the basic X, Y, Z axes also.

2-5 BLOCK I (100-SERIES SYSTEMS)

The Block I weights reported in E-1142 have represented the basic Block I configuration. This configuration was not expected to be used for flight tests. All flight systems were to be Block II which would incorporate all changes necessary for flight. Recent scheduling decisions have made it necessary to use systems earlier than Block II for in-flight tests. Accordingly, a series of modifications to the basic zero-series Block I have been approved by NASA (Ref: MSC TWX No. E G04-17-64-208) to identify the 100-series Block I flight systems (previously called Block IF). The weight reporting for Block I this month is for the zero-series configuration. As the design details of the 100-series systems become firm, the Block I status reporting will begin to represent the 100-series systems.

BLOCK I COMMAND MODULE

Changes from zero-series to 100-series Block I G&N systems include: (1) addition of an horizon photometer and star tracker with associated electronics (2) a redesigned packaging of the flight computer, (3) modification of the electronics packaging to achieve moisture proofing and to solve deficiencies in S&ID thermal interface material, (4) less flammable wiring insulation, and (5) addition of insulation to the cold surfaces.

2-6 COMMAND MODULE POWER REQUIREMENTS.

The power requirements of the Command Module G&N equipment on the primary +28 VDC power supply are shown in figure 2-1, which presents the magnitude and location of dissipated power values on a subassembly level. This chart assumes a 14-day lunar orbit mission as defined by S&ID for power profile computation (Ref: S&ID letter 63 MA 7332).

Table 2-III shows the magnitude and location of power dissipation for the established G&N activities, each of which consists of various power levels of operation.

Table 2-IV shows the energy requirements for each G&N activity on a power level basis. The table is based upon MIT letter AG 679-6, "G&N Power Profile Status," dated August 14, 1963. The vertical column to the left indicates the various G&N activities (phases of operation) for the model 14-day mission submitted by S&ID in S&ID letter 63 MA 7332. The column also indicates the power requirement and operating time for each specific activity. The top row indicates the power requirement and operating time of each G&N power consuming equipment. The table sums up the energy consumptions for each G&N activity and each G&N power consuming equipment.

BLOCK I COMMAND MODULE

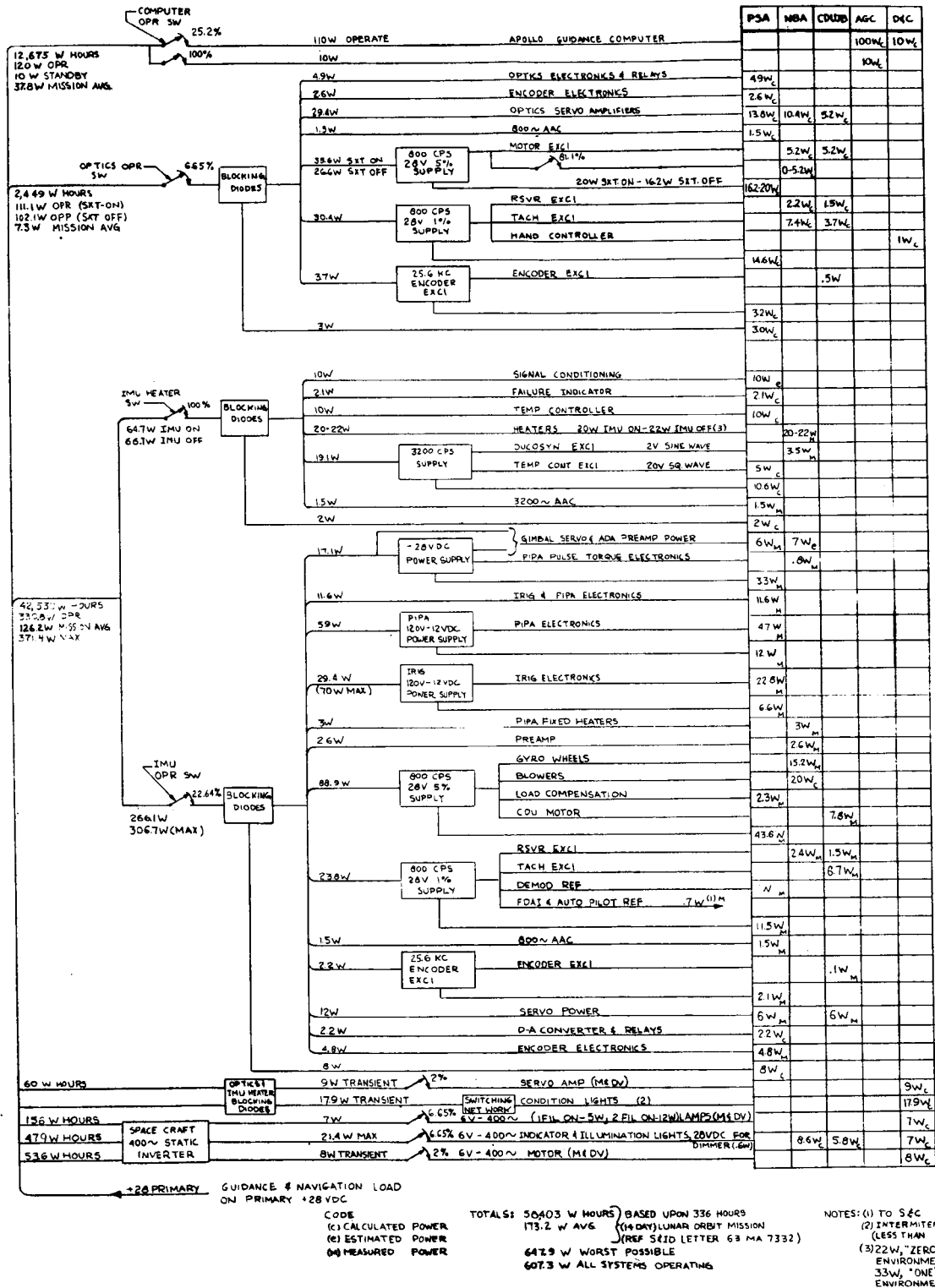

Figure 2-1. Electrical Load on Primary +28 VDC Power Supply

BLOCK I
COMMAND MODULE

Table 2-III. Nominal Power Dissipation (watts) vs G&N Activity

MODE	G&N Activity (power levels)	NBA		CDU JB	PSA		AGC	Thermal Load On S/C Coolant	D&C and S&C	Electrical Load
		IMU	OBA		IMU	OBA				
A	IMU & AGC Operate (1, 4)	74.5	0	22.1	233.5	0	110	440.1	10.7	450.8
B	IMU Alignment (1, 2, 4, 6)	74.5	39	44	233.5	63.6	110	564.6	42.7	607.3
C	Low-Orbit Navigation (1, 3, 4, 6)	74.5	33.8	44	233.5	59.8	110	555.6	42.7	598.3
D	Standby & Computing (1, 5)	25.5	0	0	41.2	0	110	176.7	10	186.7
E	Midcourse Navigation (1, 2, 5, 6)	25.5	39	21.9	41.2	63.6	110	301.2	42	343.2
F	IMU & AGC Standby (5, 7)	25.5	0	0	41.2	0	10	76.7	0	76.7
G	IMU Operate & AGC Standby (4, 7)	74.5	0	22.1	233.5	0	10	340.1	0.7	340.8

- 1. AGC 120 watts
- 2. Optics, SXT on 111.1 watts
- 3. Optics, SXT off 102.1 watts
- 4. IMU Operate 330.8 watts
- 5. IMU Standby 66.7 watts
- 6. Display and Control 45.4 watts
- 7. AGC Standby 10 watts

BLOCK I

COMMAND MODULE

Table 2-IV. Block I Command Module Power Profile for 14-Day Lunar Orbit Mission

M O D E	G&N Activity	Energy Consumption (kwh)							Total
		(1) AGC Operate 120 watts 84.67 hrs	(2) Optics SXT on 111.1 watts 18.53 hrs	(3) Optics SXT off 102.1 watts 3.83 hrs	(4) IMU Operate 330.8 watts 76.09 hrs	(5) IMU Standby 66.7 watts 260.32 hrs	(6) Display & Controls 45.4 watts 22.36 hrs	(7) AGC Standby 10.0 watts 251.74 hrs	
A	IMU & AGC Operate 450.8 watts, 56.71 hrs	6.805	--	--	18.759	--	--	--	25.564
B	IMU Alignment 607.3 watts, 8.20 hrs	0.984	0.911	--	2.712	--	0.372	--	4.979
C	Low-Orbit Navigation 598.3 watts, 3.83 hrs	0.459	--	0.391	1.266	--	0.173	--	2.289
D	Standby & Computing 186.7 watts, 5.60 hrs	0.672	--	--	--	0.373	--	--	1.045
E	Midcourse Navigation 343.2 watts, 10.33 hrs	1.239	1.147	--	--	0.689	0.468	--	3.543
F	IMU & AGC Standby 76.7 watts, 244.39 hrs	--	--	--	--	16.300	--	2.443	18.743
G	IMU Operate & AGC Standby 340.8 watts, 7.35 hrs	--	--	--	2.431	--	--	0.073	2.504
	TOTAL	10.159	2.058	0.391	25.168	17.362	1.013	2.516	58.667

~~CONFIDENTIAL~~
BLOCK II
COMMAND MODULE

Section 3

BLOCK II COMMAND MODULE DATA

3-1 RELIABILITY

The following numbers do not assume the use of in-flight spares or repair but do include the use of a redundant computer. Estimated Command Module G&N reliability is based on the 138-hour mission as defined in the Lunar Landing Mission Design Plan. The changes in reliability result from a refinement of calculations.

Table 3-I. Reliability (as of 7/15/64)

Subsystem	Operating Time (hrs) Full Power	Probability of Mission Success
IMU	31	0.99576**
AGC (2)	19*	0.99996**
DSKY	19	0.99995**
PSA	31*	0.99421**
CDU (5)	31	0.99426**
Optics	18	0.99804**
Total G&N System		0.98229**

*Certain assemblies function continuously.

**Changes since last month's report, E-1142 (Rev. 21).

3-2 WEIGHTS

Table 3-II presents the weights of all Block II equipment. Refer to section 2-1 for a general explanation of weight reporting.

3-3 REPORTED WEIGHT CHANGES

3-3.1 BELLOWS ASSY. See section 2-2.2.

3-3.2 D&C/AGC (LEB and MP). The 5.4-pound decrease for each D&C/AGC results from the use of smaller relays.

~~CONFIDENTIAL~~
BLOCK II
COMMAND MODULE

Table 3-II. Current Weight Status of Block II Command Module (lbs at 1 g)

Item	Status 2/64 (a)	(b-a)	Status 6/64 (b)	(c-b)	Status 7/64 (c)	Design Load Wt. 5/64 (d)
<u>G&N SYSTEMS</u>						
CDU Assy	15.0 (E)	+7.9	22.9 (E)	0.0	22.9 (E)	
Optical Subsystem						
SXT	18.2 (C)	+0.5	18.7 (C)	0.0	18.7 (C)	
SCT	13.8 (C)	+0.5	14.3 (C)	0.0	14.3 (C)	
Optical Base & Gearing	16.7 (E)	+0.3	17.0 (E)	0.0	17.0 (E)	
Optical Eyepieces						
SXT	1.3 (E)	+0.3	1.6 (E)	0.0	1.6 (E)	
SCT	2.3 (E)	+0.3	2.6 (E)	0.0	2.6 (E)	
NVB & Resilient Mounts	22.0 (E)	-4.0	18.0 (E)	0.0	18.0 (E)	
Bellows Assy	13.5 (M)	0.0	13.5 (M)	-0.8	12.7 (M)	
IMU	42.0 (E)	0.0	42.0 (E)	0.0	42.0 (E)	
Coolant Hoses (two)	1.0 (E)	-0.3	0.7 (E)	0.0	0.7 (E)	
Power Servo Assy	41.6 (E)	0.0	41.6 (E)	0.0	41.6 (E)	
G&N Interconnection Assy	35.2 (E)	-5.2	30.0 (E)	0.0	30.0 (E)	
G&N to S/C Interface Assy	8.0 (E)	0.0	8.0 (E)	0.0	8.0 (E)	
AGC (2 complete computers)	84.0 (E)	+4.0	88.0 (E)	0.0	88.0 (E)	
Optical Shroud	3.5 (M)	-0.4	3.1 (E)	0.0	3.1 (E)	
<u>LOWER EQUIPMENT BAY</u>						
<u>D&C</u>						
D&C Electronics	1.5 (E)	0.0	1.5 (E)	0.0	1.5 (E)	
Control Electronics	2.9 (E)	-0.9	2.0 (E)	0.0	2.0 (E)	
G&N Ind Cont Panel	11.1 (E)	0.0	11.1 (E)	0.0	11.1 (E)	
MDV (includes 2 films)	8.3 (E)	+1.3	9.6 (E)	0.0	9.6 (E)	
D&C/AGC	20.6 (E)	-0.2	20.4 (E)	-5.4	15.0 (E)	

~~CONFIDENTIAL~~
BLOCK II
COMMAND MODULE

Table 3-II. Current Weight Status of Block II Command Module (lbs) (cont)

Item	Status 2/64 (a)	(b-a)	Status 6/64 (b)	(c-b)	Status 7/64 (c)	Design Load Wt. 5/64 (d)
<u>MAIN PANEL AREA</u> D&C/AGC	20.5 (E)	-0.1	20.4 (E)	-5.4	15.0 (E)	
<u>LOOSE STORED ITEMS</u> Eye Relief Eyepieces	1.5 (E)	0.0	1.5 (E)	0.0	1.5 (E)	
Film Cartridges (3)	1.8 (E)	+0.1	1.9 (E)	0.0	1.9 (E)	
AGC Covers (2)	8.5 (E)	-4.0	4.5 (E)	0.0	4.5 (E)	
PSA Cover	3.5 (E)	0.0	3.5 (E)	0.0	3.5 (E)	
Optics Cover	1.7 (E)	-0.1	1.6 (M)	0.0	1.6 (M)	
TOTAL	400.0* Control Weight	0.0	400.0	-11.6	388.4	492.6**
*Control Weight specified in letter (PG-64-113, March 6, 1964) from Mr. D. Gilbert, ASPO, to Mr. M. Trageser, MIT/IL. See paragraph 2-1.2.						
**Design Load Weight taken from S&ID letter 63 MA 2032, February 11, 1964. Does not include loose stored items.						

BLOCK II COMMAND MODULE

3-4 BLOCK II WITH DIGITAL STABILIZATION AND CONTROL FUNCTIONS

The Block II Command Module G&N System reported here is the system concept planned until June 4, 1964. On this date, MSC reoriented the Block II G&N System to include spacecraft powered and free fall stabilization and control functions (Ref: minutes of meeting, S&ID, MIT/IL, and MSC, Implementation Meeting No. 1, June 4, 1964, MSC, Houston, Texas).

The effect of these changes on system hardware has not yet been fully assessed and will not be reflected in this report until next month.

3-5 POWER REQUIREMENTS

The power requirements of the Block II Command Module G&N equipment on the primary +28 VDC power supply are shown in figure 3-1, which presents the magnitude and location of dissipated power values on a subassembly level. This chart assumes a 14-day lunar orbit mission as defined by S&ID for power profile computation (Ref: S&ID letter 64 MA 3540).

Table 3-III shows the energy consumptions on a G&N activity and G&N equipment basis. The vertical column to the left indicates the various G&N activities (phases of operation). This column also indicates the power requirement and operating time for each specific activity. The top row indicates the power requirement and operating time of each G&N power-consuming equipment.

BLOCK II COMMAND MODULE

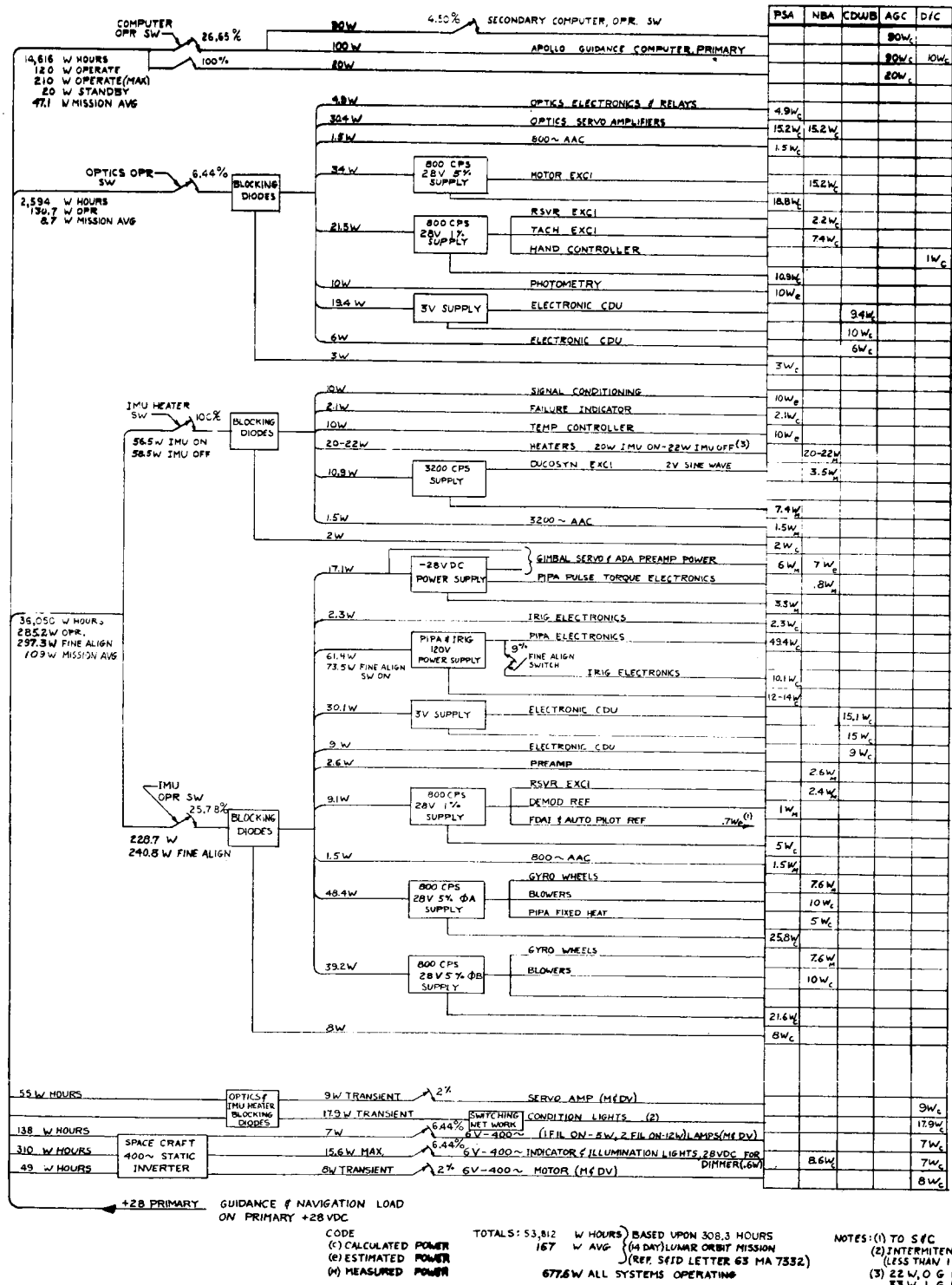

Figure 3-1. Electrical Load on Primary +28 VDC Power Supply

**BLOCK II
COMMAND MODULE**

Table 3-III. Block II Command Module Power Profile for 14-Day Lunar Orbit Mission

Operating Mode		SUMMARY OF BLOCK II COMMAND MODULE ENERGY CONSUMPTION (Kilowatt Hours)							TOTAL
		1 AGC Operate 78.47 hours 120 watts	2 AGC Operate 3.10 hours 210 watts	3 AGC Standby 225.40 hours 5 watts	4 INTU Operate 78.47 hours 285.2 watts	5 INTU Standby 226.10 hours 5 watts	6 DRC Operate 18.85 hours 38.8 watts	7 DRC Operate 18.85 hours 130.7 watts	
A	Accomplish & confirm course corrections Inactivity & Monitor 405.2 watts 55.72 hrs.	6.666	---	---	15.881	---	---	---	22.577
B	Alignments Landmark Trackings SXT Sightings 575.5 watts 12.69 hrs.	1.523	---	---	3.619	---	0.503	1.658	7.303
C	Star Occultation Sightings 178.5 watts 2.90 hrs.	0.348	---	---	---	---	0.170	---	0.518
D	SXT Sightings (Midcourse) 348.8 watts 7.16 hrs.	0.859	---	---	---	---	0.418	0.936	2.496
E	Inactivity & Monitor 78.5 watts 217.31 hrs.	---	---	4.346	---	---	12.713	---	17.059
F	Inactivity & Monitor 305.2 watts 8.09 hrs.	---	---	0.162	2.307	---	---	---	2.469
G	Computer Updates Major Maneuvers 495.2 watts 2.97 hrs.	---	0.624	---	0.847	---	---	---	1.471
H	Computer Updates 268.5 watts 0.73 hrs.	---	0.153	---	---	---	0.043	---	0.196
	TOTAL 308.30 hours	9.416	0.777	4.508	22.664	13.344	0.786	2.594	54.089

BLOCK II
COMMAND MODULE

3-6 STATUS OF COMMAND MODULE AGC PROGRAMS

Table 3-IV lists current Command Module memory estimates and the status of AGC programs. The status of LEM AGC programs is not reported at this time.

A high and low word estimate is given with each program. Each status is defined as follows:

- (1) Planning stage
- (2) Programming stage
- (3) Checkout on AGC simulation
- (4) Checkout on G&N simulation
- (5) Checkout on AGC

Table 3-IV. Current Memory Estimates and the Status
of Command Module AGC Programs

Program	Status	Memory Estimate (words)	
		High	Low
List Processing Interpreter	(5)	1712	1712
AGC Executive	(5)	253	253
AGC Waitlister	(5)	145	145
AGC System Exerciser	(5)	500*	294*
G&N System Exerciser	(4)	650	400
Display, Keyboard, and Telemetry	(5)	2000	2000
Input/Output Control	(5)	1750*	1275*
Midcourse & Orbital Navigation	(5)	2000*	1500*
Midcourse & Orbital Guidance	(3)	500	500
Pre-Launch Platform Alignment	(5)	400*	350*
In-Flight Platform Alignment	(4)	1024	900
Re-Entry Control	(4)	1800	1200
Injection and De-Boost	(4)	1000	400
Restart	(5)	500*	200*
Aim-Point Determination & Abort	(1)	4000	2000
Totals		18234	13129

*Programs in stage (5) whose low and high estimates are not identical reflect an anticipated increase in computational facility.

~~CONFIDENTIAL~~

LUNAR EXCURSION MODULE

Section 4

LUNAR EXCURSION MODULE DATA

4-1 RELIABILITY

The numbers in table 4-I do not assume the use of in-flight spares or repair. Changes in reliability values result from a refinement in calculations. The estimated reliabilities are based on MIT/IL's Guidance Monitor System Note No. 3, dated January 23, 1964.

Table 4-I. Reliability (as of 7/15/64)

Subsystem	Operating Time (hrs)	Probability of Mission Success
IMU	6.25	0.99914
AGC	6.25	0.99768*
PSA	6.25	0.99928*
CDU (5)	6.25	0.99897*
OMU	0.75	0.99997
Total G&N System		0.99505*

*These values have changed since the last report (Rev. 21).

4-2 WEIGHTS FOR LEM

Lunar Excursion Module weights are presented in table 4-II. In general the data conform to the information contained in paragraphs 2-1, 2-1.1, and 2-1.2.

The row labeled "Bare Guidance System" is inserted to provide for comparisons with similarly specified systems.

At NASA coordination meeting L6A, May 26 and 27, 1964, the installation configuration of the telescope and IMU was changed from the existing installation, wherein the IMU was inside the LEM pressure shell, to an outside configuration. Moreover, the vibration environment recently specified in preliminary ICD LIS-520-10001, dated May 26, 1964, "LEM Design Environment," states levels which are much greater than anticipated in the G&N design. Vibration isolation mounts for the telescope and IMU

~~CONFIDENTIAL~~

~~SECRET~~
BLOCK II
LUNAR EXCURSION MODULE

Table 4-II. Estimated Weights of LEM G&N Components (lbs. at 1 g)

Item	Status 2/64 (a)	(b-a)	Status 6/64 (b)	(c-b)	Status 7/64 (c)	Design Load Wt. 7/64 (d)
CDU's	15.0 (E)	+7.9	22.9 (E)	0.0	22.9 (E)	**
Telescope and All Eyepieces	24.5 (E)	0.0	24.5 (E)	0.0	24.5 (E)	
Eye Register for Reticule	2.0 (E)	0.0	2.0 (E)	0.0	2.0 (E)	
Two-Digit Readout for Reticule	5.0 (E)	0.0	5.0 (E)	0.0	5.0 (E)	
IMU	42.0 (E)	0.0	42.0 (E)	0.0	42.0 (E)	
AGC/PSA Interconnection Assy	10.0 (E)	0.0	10.0 (E)	0.0	10.0 (E)	
AGC Display and Controls	19.5 (E)	0.0	19.5 (E)	-4.5	15.0 (E)	
Other Display and Controls	15.0 (E)	0.0	15.0 (E)	0.0	15.0 (E)	
Book of Procedures, etc	2.0 (E)	0.0	2.0 (E)	0.0	2.0 (E)	
AGC	41.5 (E)	+2.5	44.0 (E)	0.0	44.0 (E)	
AGC Cover	4.3 (E)	-2.0	2.3 (E)	0.0	2.3 (E)	
PSA	24.8 (E)	0.0	24.8 (E)	0.0	24.8 (E)	
PSA Cover	2.4 (E)	0.0	2.4 (E)	0.0	2.4 (E)	
TOTAL	210.0 * Control Weight	+6.4	216.4	-4.5	211.9	
Bare Guidance System (IMU, PSA, and computer)	108.3	+2.5	110.8	0.0	110.8	

* Control Weight specified in Letter PG-64-113 (March 6, 1964) from Mr. D. Gilbert, ASPO, to Mr. M. Trageser, MIT/IL. See section 2-1.2.

** No design load weight has been assigned.

LUNAR EXCURSION MODULE

would be required. However, at NASA Coordination Meeting L7A, June 4, 1964, GAEC lowered its estimate of flight vibration environment by a factor of 5. Accordingly, the vibration mounts were removed. The design changes resulting from this activity are not yet reflected in this weight report.

4-3 REPORTED WEIGHT CHANGES

4-3.1 AGC DISPLAY AND CONTROLS. See section 3-3.2 for an explanation of the 4.5-pound decrease.

4-4 POWER REQUIREMENTS

The estimate for LEM power and energy consumption shown in figure 4-1 is based upon recent Command Module G&N Block II data and preliminary ICD LIS-390-2, LEM Electrical Load Analysis Form.

Table 4-III shows the energy requirements for each G&N activity on a power level basis. The table is also based upon LEM ICD LIS-390-2. The vertical column to the left indicates the various G&N activities (phases of operation). The column also indicates the power requirement and operating time for each specific activity. The top row indicates the power requirement and operating time of each G&N power consuming equipment. The table sums up the energy consumption for power consuming equipment.

LUNAR EXCURSION MODULE

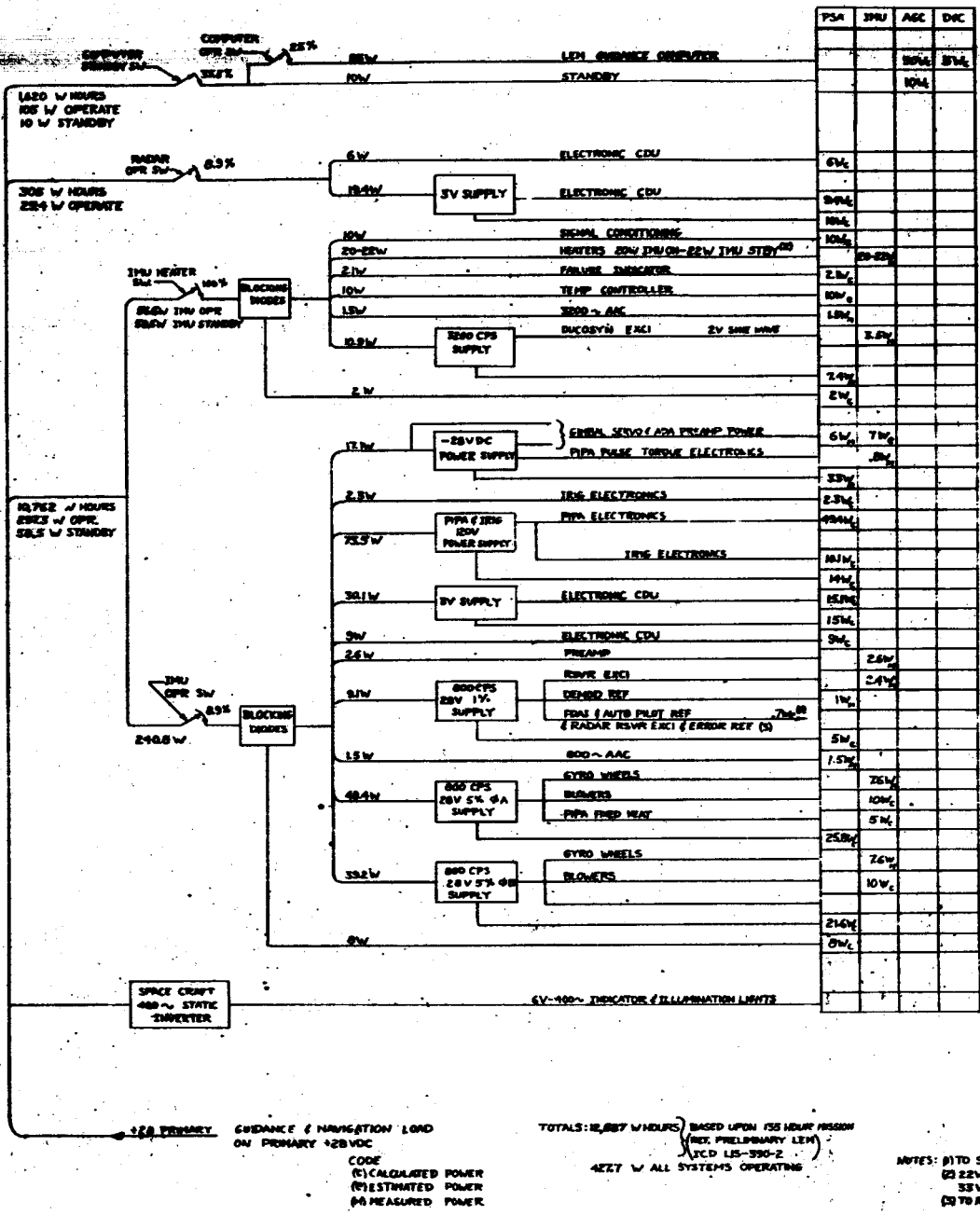

Figure 4-1. Electrical Load on Primary +28 VDC Power Supply

LUNAR EXCURSION MODULE

Table 4-III. LEM Power Profile Based on LEM ICD LIS-390-3

Summary of Lunar Excursion Module Energy Consumption in Kilowatt Hours									
Mode	LEM C&N Activity	ACB 0 watts	ACD 100 watts 11.5 hours	ACD 100 watts 26.75 hours	ACD 297.5 watts 11.5 hours	ACD 50.5 watts 12.0 hours	ACD 200 watts 11.5 hours	ACD 11.5 hours Negligible	Total
I	Inactivity 87.40 hours 68.5 watts	0.000	—	—	—	—	5.113	—	5.113
II	Inactivity Alignment Midcourse Measurements 11.72 hours 427.7 watts	—	1.281	—	—	—	3.484	Negligible	5.013
III	Guidance During Major Event 0.20 hours 427.7 watts	—	0.021	—	—	—	0.069	—	0.069
IV	Inactivity 20.05 hours 68.5 watts	—	—	0.20	—	—	—	1.173	1.373
V	Inactivity 15.70 hours 68.5 watts	—	—	0.197	—	—	—	0.918	1.075
	Total Hours	0.000	1.282	0.397	3.543	7.204	0.303	Negligible	12.689

Section 5

GLOSSARY AND SYSTEM DEFINITION

Apollo Guidance Computer (AGC)

CM BLOCK I A single complete flight computer containing all logic, memory, associated power supplies, and all interface circuits except those identified with the CDU's. Does not contain the associated displays and controls.

Consists of two trays containing replaceable electronic modules, the AGC end connector, and toe plate. Does not include the necessary cold plate or the G&N to S/C Interface Assembly which is located in the adjacent area. Space exists for carrying an extra spare pair of AGC trays. These would not function in this spares location but could interchange with faulty trays in the active position. The spare trays are reported separately.

CM BLOCK II Two complete and active computers each having the same functions as the Block I AGC. Consists of two wiring matrix headers mounted on each side of the cold plate. This cold plate is not included in this accounting and must be moved up from the Block I configuration location. The modules of the "X" computer mount on one of these headers, those of the "Y" computer on the other.

Block I and Block II AGC's are not interchangeable.

LEM A single complete flight computer having the same functions as one of the Block II computers. Unless installation constraints yet to be determined prevent it, the LEM computer will be physically identical with the Block II computers.

AGC Covers

CM BLOCK I Not required.

CM BLOCK II Two covers, one for each computer, may be required if it becomes necessary to seal the Malco connectors against moisture.

LEM Same as Block II except that there is only one cover.

AGC Spares

CM BLOCK I Spare AGC logic and memory trays.

CM BLOCK II AND LEM No spares.

Alignment Optical Telescope (AOT)

CM BLOCK I AND BLOCK II Not in CM; see Optical Subsystem.

LEM A 3-position periscope with single-degree-of-freedom manually read reticule for alignment of the IMU. Includes the weight of the bellows assembly and the long-eye-relief eyepiece.

Bellows Assembly

CM BLOCK I AND CM BLOCK II Flexible pressure seal between CM structure and optical subsystem on NAV BASE for penetration of pressure hull with optics.

LEM One bellows with a double convoluted wall and two seals providing a flexible seal for pressure penetration of the AOT in the spacecraft. This weight is included in the AOT value.

Book of Procedures

CM Not in CM; see MDV.

LEM Book or other form of maps, charts, procedures, instructions, etc., needed for lunar operations.

Coupling Data Unit (CDU) Assembly

The CDU provides the necessary signal interfaces among the IMU gimbal angles, optics gimbal angles, radar gimbal angles, angle registers in the AGC, the spacecraft autopilot attitude error signals, and the tracking radar command error signals.

CM BLOCK I Five interchangeable gear boxes each with necessary motor tachometer, resolver synchros, and encoder with mounting frame work. Does not include associated electronics which are located in the PSA.

CM BLOCK II Functionally identical to Block I except the instrumentation is all electronic. Includes all support electronics (including special power supply) and header; is located in same volume as Block I CDU's. Changes in resolver synchro characteristics and mode controls make Block I and II CDU's noninterchangeable.

LEM Interchangeable with CM Block II CDU's except for the headers.

Cold Plates

CM BLOCK I, BLOCK II, AND LEM Cold plates for the IMU are built into the IMU. Necessary cold plates for electronics are part of the equipment supplied by the spacecraft manufacturer.

Control Electronics Assembly

CM BLOCK I Consists of one power transformer, one relay and diode module, and a bracket end connector. Used to support display and control functions.

CM BLOCK II May be relocated with other similar functions.

LEM Not defined in LEM.

Coolant Hoses

CM BLOCK I AND CM BLOCK II Consists of (1) two aluminum flex coolant hoses, one between IMU and spacecraft and one between optics and spacecraft, (2) bracket assembly screws and clamp, and (3) entrapped coolant. Note that a third aluminum flex coolant hose between the optics and the IMU is considered as part of the weight of the optics base.

LEM Not identified as part of LEM.

Display and Control/Apollo Guidance Computer (D&C/AGC)

CM BLOCK I Number displays and keyboard control associated with the operation of the AGC. Two functionally identical and parallel operation units: one in lower equipment bay and one on main panel between left and center couches.

CM BLOCK II Functionally identical to Block I but smaller configuration because of smaller relays.

LEM Identical to Block II except only a single unit is required.

D&C Electronics Assembly

CM BLOCK I Consists of a chassis, a relay and diode module, a demod. elect. module, a saturable reactor, a time delay module, a connector, and wiring. Used to support display and control functions.

CM BLOCK II Not defined at this time.

LEM Not defined in LEM at this time.

Eye Register for Reticule

CM Not in CM.

LEM Device or equipment not yet defined in detail, to position the LEM pilot's eye to use the window marking reticule pattern for landing point observation and selection during the constant flight path phase of landing.

Film Cartridges

CM BLOCK I AND BLOCK II Consists of film cartridges and film for map and data viewer.

LEM Does not exist in LEM.

G&N Indicator Control Panel

CM BLOCK I AND BLOCK II Consists primarily of controls and displays for the operation of the optics, MDV, IMU temperature control, panel brightness control, and attitude impulse control. It includes display and control elements, panel, panel wiring, and supporting hardware. Block II panel will probably contain horizon photometer controls also.

LEM Not defined at this time for LEM.

G&N Interconnection Assembly

CM BLOCK I Consists of PSA End Connector Assembly and interconnect wiring harness which electrically ties together the assemblies that constitute a completely integrated system. This term does not include the G&N to S/C Interface Assembly weight or the weights of harness support brackets which are an NAA responsibility.

CM BLOCK II Similar to Block I but not interchangeable with Block I.

LEM Not clearly defined but at present is called the AGC/PSA Interconnection Assy. Because of the wide separation of G&N components, most interconnection will be accomplished as part of spacecraft wiring.

G&N to S/C Interface Assembly

CM BLOCK I Interconnections between the spacecraft wiring channel, the computer end connector, and the PSA end connector. Contains no active electronics. The G&N Harness Tray Assy is also included as part of this assembly.

CM BLOCK II Similar in function to Block I except the configuration is much different and not interchangeable with Block I.

LEM Not identified yet as a separate item in LEM.

Horizon Photometer

CM BLOCK I Only 100-Series Systems will have a horizon photometer and star tracker, using a Block II optical sextant. Zero-series Block I weights do not include an horizon photometer.

CM BLOCK II An earth horizon brightness photometer and automatic star tracker for navigation measurements against the earth's illuminated limb. The sensors are incorporated into the head of the SXT, the weight of which includes this function. The PSA includes support electronics.

LEM Not part of LEM.

Inertial Measurement Unit (IMU)

CM BLOCK I Size 14 IMU (14-inch case diameter) gimbal assembly including all parts inside hermetic case and including entrapped coolant.

CM BLOCK II Size 12.5 IMU functionally interchangeable with Block I unit, but not physically interchangeable with Block I.

LEM Size 12.5 IMU as described above.

IMU Control Panel

CM BLOCK I Consists of panel, wiring, attitude error meter, CDU transfer switch, manual alignment switch, CDU mode control switches, connector, and supporting hardware.

CM BLOCK II Does not exist in Block II. Moding is done by AGC program and AGC push buttons.

LEM Not defined at this time for LEM.

Long-Eye-Relief Eyepieces

CM BLOCK I AND BLOCK II Consists of a SXT and a SCT eyepiece to provide eye relief of at least 1.6 inches for closed-visor operation. Used in place of normal eyepieces of SXT and SCT.

LEM Long-eye-relief eyepiece for the AOT is included as part of the AOT in this accounting.

Map and Data Viewer (MDV)

CM BLOCK I AND BLOCK II Film viewer for display of maps, charts, procedures, etc. Weight includes one film cartridge for Block I MDV and tentatively two for Block II MDV.

LEM Not in LEM; see Book of Procedures.

NVB and Resilient Mounts

CM BLOCK I Rigid beryllium structure supporting the IMU and the optical subsystem with its associated hardware. The NVB is attached to the spacecraft using flexible resilient mounts to prevent spacecraft strains from distorting the NVB and the alignment between the IMU and Optics. These mounts also provide shock and vibration attenuation.

CM BLOCK II Functionally similar to Block I but will be lighter and provide for mounting the size 12.5 IMU.

LEM The need for tying the AOT and IMU together exists but is accomplished by using structure provided by the spacecraft contractor. See paragraph 4-2.

Optical Eyepieces

CM BLOCK I AND BLOCK II Removable SXT eyepiece and SCT eyepiece.

LEM Included as part of the AOT.

Optical Subsystem

CM BLOCK I Consists of SXT, SCT, Optical Base, and associated hardware defined as follows:

- SXT: Sextant -- a two-line-of-sight, narrow-field, two-degree-of-freedom sextant and its attached gearing.
- SCT: Scanning Telescope -- a single-line-of-sight, wide-field-of-view, two-degree-of-freedom articulation optical instrument and its attached gearing.
- OPTICAL BASE: Base for SXT and SCT with associated gearing and internal cooling. Includes the weight of the coolant hose between the IMU and Optical Base.

CM BLOCK II Similar to Block I except for changes in the sextant to provide line-of-sight velocity control directly without CDU's. The horizon photometer and automatic star tracker are incorporated into the SXT.

LEM Not in LEM; see AOT.

Optical Shroud & Cover Assembly

CM BLOCK I AND BLOCK II Consists of the optical shroud and protective cover.

LEM Does not exist in LEM.

Power Servo Assembly (PSA)

CM BLOCK I Consists of most of the support electronics: power supplies; IMU, Optics, and CDU servos; IMU temperature control; accelerometer and gyro pulse torquing; and signal conditioning electronics. Consists of 10 trays with replaceable modules which plug into the PSA end connector assembly. Includes front toe plate but not the cold plate.

CM BLOCK II Similar in function to Block I but does not contain the CDU servos and signal conditioning electronics needed in Block I. Includes electronics for horizon photometer and automatic star tracker. Consists of a single plane matrix header to mount onto the cold plate with the modules plugging onto the top.

LEM Consists of electronics similar to those identified in the Block II PSA minus various electronics modules. Does not include CDU, Optics, and Photometry electronics associated with the Block II PSA.

PSA End Connector Assembly

CM BLOCK I Electrical interconnection between the PSA trays, the G&N Interconnection Assy, and the G&N to S/C Interface Assy. The End Connector weight is reported in the G&N Interconnection Assembly weight.

CM BLOCK II & LEM Not identified as a separate item; will be part of the PSA matrix header.

PSA Covers

CM BLOCK I Not required.

CM BLOCK II Cover to protect the PSA module connections from moisture during flight.

LEM Same as Block II except lighter in weight.

Signal Conditioner Assembly

CM BLOCK I AND II & LEM Condition signals for telemetry.

Two-Digit Readout for Reticule

CM Not in CM.

LEM A 2-digit readout driven by the AGC from 00 to 99 to indicate range component of landing point using fixed numbered scale on window reticule.