

Technical Library, Bellcomm, Inc.

3902-H012-RO-000

TRW NOTE NO. 66-FMT-402

PROJECT APOLLO JUN 12 1968

---

APOLLO MISSION AS-206A  
SPACECRAFT REFERENCE TRAJECTORY

---

Prepared by  
Trajectory Design Section  
TRW Systems

VOLUME I  
TRAJECTORY DESCRIPTION

A-21

28 FEBRUARY 1966

*DRA  
(Other volumes?)*

(NASA-CR-133283) APOLLO MISSION AS-206A  
SPACECRAFT REFERENCE TRAJECTORY. VOLUME  
1: TRAJECTORY DESCRIPTION (TRW Systems  
Group) 92 p

N73-73426

00/99

Unclas  
17962

Prepared for  
MISSION PLANNING AND ANALYSIS DIVISION  
NATIONAL AERONAUTICS AND SPACE ADMINISTRATION  
MANNED SPACECRAFT CENTER  
HOUSTON, TEXAS

*RKP*  
RKP

3902-H012-R0-000

TRW NOTE NO. 66-FMT-402

PROJECT APOLLO

---

APOLLO MISSION AS-206A  
SPACECRAFT REFERENCE TRAJECTORY

---

28 FEBRUARY 1966

VOLUME I  
TRAJECTORY DESCRIPTION

Prepared for  
MISSION PLANNING AND ANALYSIS DIVISION  
NATIONAL AERONAUTICS AND SPACE ADMINISTRATION  
MANNED SPACECRAFT CENTER  
HOUSTON, TEXAS  
NAS 9-4810

Approved by: *C. R. Huss*

C. R. Huss, Chief  
Flight Analysis  
Branch  
NASA/MSC

Prepared by: R. M. Diamond

W. B. Gray  
R. D. Shinkle  
F. J. Sichi  
T. E. Vogt  
TRW Systems

Approved by: *John P. Mayer*

John P. Mayer, Chief  
Mission Planning and  
Analysis Division  
NASA/MSC

Approved by: *C. V. Stableford*

C. V. Stableford,  
Acting Manager  
Mission Design Department  
TRW Systems

Approved by: *C. W. Pittman*

for C. W. Pittman, Manager  
Mission Planning and  
Operations  
TRW Systems

**TRW SYSTEMS**

## FOREWORD

This report, which defines the Spacecraft Reference Trajectory for Apollo Mission AS-206A, is submitted to NASA/Manned Spacecraft Center by TRW Systems in partial response to Task MSC/TRW A-21 (Establishment of the Reference Trajectory for Apollo Mission AS-206A), with Amendment Number 1, of the Apollo Mission Trajectory Control Program (Contract No. NAS 9-4810).

This report is presented in three volumes. Volume I summarizes the mission requirements, the unclassified spacecraft input data used in the generation of the mission profile, and the significant trajectory analyses. Volume I also contains graphical and tabular time histories of pertinent spacecraft attitude, position, motion, separation characteristics, and MSFN coverage data. Volume II of this report contains the trajectory listing of selected mission profile parameters, and the confidential spacecraft input data specifications. Volume III presents detailed time histories of radar range, range rate, elevation, elevation rate, azimuth, azimuth rate, and four look-angles for the MSFN ground stations available for operation during this mission.

## CONTENTS

	Page
1. INTRODUCTION AND SUMMARY . . . . .	1
1.1 Purpose . . . . .	1
1.2 Scope . . . . .	1
1.3 Mission Profile Summary . . . . .	2
2. SPACECRAFT MISSION REQUIREMENTS. . . . .	9
2.1 Spacecraft Test Objectives. . . . .	9
2.1.1 Primary Spacecraft Test Objectives . . . . .	9
2.1.2 Secondary Spacecraft Test Objectives . . . . .	9
2.2 Mission Profile Guidelines . . . . .	9
2.2.1 Launch Vehicle Guidelines . . . . .	9
2.2.2 MSFN Coverage/Flight Control Guidelines . . . . .	9
2.2.3 LEM Attitude Guidelines . . . . .	10
2.2.4 LEM Propulsion Guidelines . . . . .	11
2.2.5 General Mission Guidelines . . . . .	12
3. SUMMARY OF INPUT DATA . . . . .	13
3.1 Saturn IB Launch Vehicle. . . . .	13
3.2 Spacecraft (LEM-1) . . . . .	13
3.3 MSFN Stations . . . . .	13
3.4 Earth Constants and Conversion Factors . . . . .	14
3.4.1 Earth Constants . . . . .	15
3.4.2 Conversion Factors . . . . .	15
3.5 Spacecraft and Attitude Reference Coordinate Systems . . . . .	16
3.5.1 Spacecraft Coordinate System, $\bar{X}_S, \bar{Y}_S, \bar{Z}_S$ . . . . .	16
3.5.2 Launch Site Inertial Reference System, $\bar{X}_I, \bar{Y}_I, \bar{Z}_I$ . . . . .	16
3.5.3 Launch Site Rotating Reference System, $\bar{X}_R, \bar{Y}_R, \bar{Z}_R$ . . . . .	16
3.5.4 Relative Vehicle Coordinate System, $\bar{X}_{RV}, \bar{Y}_{RV}, \bar{Z}_{RV}$ . . . . .	16

## CONTENTS (Continued)

	Page
4. MISSION DESCRIPTION. . . . .	25
4.1 Ascent-to-Orbit. . . . .	25
4.2 S-IVB/SLA/LEM Orbital Coast. . . . .	26
4.3 Spacecraft Separation . . . . .	26
4.4 Orbital Cold-Soak to First DPS Burn. . . . .	27
4.5 First DPS Burn . . . . .	27
4.6 Orbital Coast to Second DPS Burn. . . . .	28
4.7 Second DPS Burn/FITH Abort Test/First APS Burn. . . . .	28
4.7.1 Second DPS Burn . . . . .	28
4.7.2 FITH Abort Test/First APS Burn . . . . .	30
4.8 Orbital Coast to Second APS Burn. . . . .	30
4.9 Second APS Burn . . . . .	30
4.10 Orbital Coast to Third APS Burn. . . . .	32
4.11 Third APS Burn. . . . .	32
4.12 Orbital Cold-Soak to Fourth APS Burn. . . . .	32
4.13 Fourth APS Burn . . . . .	33
4.14 Final Orbital Coast. . . . .	33
4.15 Spacecraft Orbital Lifetime Estimates. . . . .	33
5. NOMINAL TRAJECTORY DATA. . . . .	41
5.1 Mission Profile Data. . . . .	41
5.2 Trajectory Phase Data . . . . .	41
6. MSFN COVERAGE DATA. . . . .	67
7. SUMMARY OF TECHNICAL ACHIEVEMENT. . . . .	79
REFERENCES. . . . .	81

## TABLES

		Page
3-1	MSFN Ground Stations and Capabilities . . . . .	17
4-1	Ballistic Coefficients . . . . .	34
4-2	Spacecraft Orbital Lifetime Estimates . . . . .	34
5-1	Time Sequence of Events . . . . .	42
5-2	Orbital Characteristics of the Spacecraft Coast Phases . .	44
5-3	Spacecraft Earth Shadow Data . . . . .	45
5-4	Ascent-to-Orbit; Discrete Events Summary . . . . .	46
5-5	SLA Petal Deployment and Spacecraft Separation; Discrete Events Summary . . . . .	47
5-6	First DPS Burn; Discrete Events Summary . . . . .	47
5-7	Second DPS Burn/FITH Abort Test/First APS Burn; Discrete Events Summary . . . . .	48
5-8	Second APS Burn; Discrete Events Summary . . . . .	48
5-9	Third APS Burn; Discrete Events Summary . . . . .	49
5-10	Fourth APS Burn; Discrete Events Summary . . . . .	49
6-1	MSFN Mission Coverage . . . . .	68
6-2	Communication Void Intervals . . . . .	74

## ILLUSTRATIONS

		Page
1-1	Mission Profile Summary . . . . .	5
3-1	Saturn IB Launch Vehicle Outboard Profile . . . . .	18
3-2	Spacecraft Reference Dimensions . . . . .	19
3-3	LEM-1 Outboard Profile . . . . .	20
3-4	Australia Apollo Tracking Ship Placement Study/ Spacecraft Separation . . . . .	21
3-5	Australia Apollo Tracking Ship Placement Study/ First DPS Burn . . . . .	21
3-6	Bermuda Apollo Tracking Ship Placement Study. . . . .	22
3-7	Spacecraft Coordinate System. . . . .	23
3-8	Spacecraft Reference Coordinate System . . . . .	23
3-9	Relative Vehicle Coordinate System. . . . .	24
4-1	Spacecraft Separation; Relative Velocity and Distance during RCS Thrusting. . . . .	35
4-2	Spacecraft Separation; Relative Velocity and Distance History for Approximately 100 Minutes . . . . .	35
4-3	Spacecraft Cold-Soak Attitude Orientation. . . . .	36
4-4	Cold-Soak Attitude Orientation History for Launches, Second Quarter 1967. . . . .	37
4-5	First DPS Burn Thrust Profile . . . . .	38
4-6	Second DPS Burn Thrust Profile . . . . .	38
4-7	Effect of Assumed IMU Drift on Orbit Dimensions Following Second DPS Burn . . . . .	39
4-8	FITH Staging; Relative Velocity and Distance History During First APS Burn. . . . .	39
4-9	FITH Staging; Relative Velocity and Distance History to 100 Seconds . . . . .	40
4-10	Effect of Assumed IMU Drift on Orbit Dimensions Following Second APS Burn . . . . .	40

## ILLUSTRATIONS (Continued)

		Page
5-1	Earth Ground Track; Revolutions One and Two . . . . .	50
5-2	Earth Ground Track; Revolution Three. . . . .	51
5-3	Earth Ground Track; Revolution Four . . . . .	52
5-4	Earth Ground Track; Revolutions Five through Nine. . . . .	53
5-5	Ascent-to-Orbit; Altitude, Geodetic Latitude, and Longitude . . . . .	54
5-6	Ascent-to-Orbit; Inertial Velocity, Inertial Flight Path Angle, and Inertial Azimuth. . . . .	54
5-7	Ascent-to-Orbit; Dynamic Pressure and Mach Number . . . . .	55
5-8	Ascent-to-Orbit; Launch Site Inertial Attitude History. . . . .	55
5-9	Spacecraft Separation; Altitude, Geodetic Latitude, and Longitude . . . . .	56
5-10	Spacecraft Separation; Inertial Velocity, Inertial Flight Path Angle, and Inertial Azimuth. . . . .	56
5-11	Spacecraft Separation; $\Delta V$ History. . . . .	57
5-12	First DPS Burn; Altitude, Geodetic Latitude, and Longitude . . . . .	57
5-13	First DPS Burn; Inertial Velocity, Inertial Flight Path Angle, and Inertial Azimuth. . . . .	58
5-14	First DPS Burn; Launch Site Inertial Attitude History. . . . .	58
5-15	First DPS Burn; $\Delta V$ History. . . . .	59
5-16	Second DPS Burn/FITH Staging/First APS Burn; Altitude, Geodetic Latitude, and Longitude. . . . .	59
5-17	Second DPS Burn/FITH Staging/First APS Burn; Inertial Velocity, Inertial Flight Path Angle, and Inertial Azimuth. . . . .	60
5-18	Second DPS Burn/FITH Staging/First APS Burn; Launch Site Inertial Attitude History . . . . .	60



## ILLUSTRATIONS (Continued)

		Page
5-19	Second DPS Burn/FITH Staging/First APS Burn; $\Delta V$ History . . . . .	61
5-20	Second APS Burn; Altitude, Geodetic Latitude, and Longitude . . . . .	61
5-21	Second APS Burn; Inertial Velocity, Inertial Flight Path Angle, and Inertial Azimuth. . . . .	62
5-22	Second APS Burn; Launch Site Inertial Attitude History. . . . .	62
5-23	Second APS Burn; $\Delta V$ History. . . . .	63
5-24	Third APS Burn; Altitude, Geodetic Latitude, and Longitude . . . . .	63
5-25	Third APS Burn; Inertial Velocity, Inertial Flight Path Angle, and Inertial Azimuth . . . . .	64
5-26	Third APS Burn; $\Delta V$ History . . . . .	64
5-27	Fourth APS Burn; Altitude, Geodetic Latitude, and Longitude . . . . .	65
5-28	Fourth APS Burn; Inertial Velocity, Inertial Flight Path Angle, and Inertial Azimuth. . . . .	65
5-29	Fourth APS Burn; $\Delta V$ History. . . . .	66
6-1	MSFN Coverage Summary . . . . .	76

## ABBREVIATIONS

APS	Ascent Propulsion System
AGS	Abort Guidance Subsystem
CSM	Command and Service Module
DPS	Descent Propulsion System
EST	Eastern Standard Time
FITH	Fire-In-The-Hole
GMT	Greenwich Mean Time
IMU	Inertial Measurement Unit
LEM	Lunar Excursion Module
LES	Launch Escape Subsystem
LMP	LEM Mission Programmer
NASA	National Aeronautics and Space Administration
MAX	Maximum
MCC	Mission Control Center
MIN	Minimum
MSC	Manned Spacecraft Center
MSFC	Marshall Space Flight Center
MSFN	Manned Space Flight Network
PCM	Pulse Code Modulation
PNGCS	Primary Navigation and Guidance Control System
RCS	Reaction Control System
SLA	Spacecraft LEM Adapter
SLR	Radar Slant Range
UHF	Ultra High Frequency
VHF	Very High Frequency

## ABBREVIATIONS (Continued)

deg	Degrees
er	Earth Equatorial Radius
ft	Feet
hr	Hours
km	Kilometers
lb	Pounds
min	Minutes
n mi	Nautical Miles
rad	Radians
sec	Seconds

## 1. INTRODUCTION AND SUMMARY

### 1.1 PURPOSE

The spacecraft reference trajectory defined in this report is designed for the unmanned AS-206A Mission. The mission profile has been designed such that the spacecraft mission objectives (Reference 1) are satisfied without violating the spacecraft constraints or the mission guidelines. The purpose of this report is to incorporate the mission design refinements issued since the publication of the Apollo Mission AS-206A Spacecraft Preliminary Reference Trajectory (Reference 2).

### 1.2 SCOPE

The Apollo Mission AS-206A reference trajectory reflects the mission refinements issued since the publication of Reference 2, incorporates the known systems test requirements, and uses the current guidance logic proposed for thrust vector and attitude control for the lunar excursion module (LEM) powered flight maneuvers. The data presented for the ascent-to-orbit phase are based on the AS-206A launch vehicle trajectory listing transmitted to MSC by the Marshall Space Flight Center (MSFC) through the Guidance and Performance Subpanel (Reference 3).

This report consists of three volumes. Volume I presents the mission requirements, a summary of the unclassified spacecraft input data used in the generation of the mission profile, a description of the major phases of the mission, and the trajectory analyses of pertinent phases. Volume I also contains graphical and tabular time histories of pertinent spacecraft attitude, position, motion, separation characteristics, and MSFN coverage data.

Volume II of this report contains the classified trajectory listing of the mission profile and the classified spacecraft input data specifications.

Volume III presents detailed time histories of radar range, range rate, elevation, elevation rate, azimuth, azimuth rate, and four look-angles for the MSFN ground stations available for operation during this mission.

### 1.3 MISSION PROFILE SUMMARY

The AS-206A mission will be the first launch of a LEM spacecraft. For mission simulation purposes, launch is assumed to occur at 13:00 hours Greenwich mean time (GMT), 1 April 1967, from launch complex 37B of the Kennedy Spaceflight Center.

Major mission events are illustrated in Figure 1-1. The mission has been divided into 14 phases for discussion purposes:

- 1) Ascent-to-orbit
- 2) S-IVB/spacecraft LEM adapter (SLA)/LEM orbital coast
- 3) Spacecraft separation
- 4) Orbital cold-soak to first descent propulsion system (DPS) burn
- 5) First DPS burn
- 6) Orbital coast to second DPS burn
- 7) Second DPS burn/fire-in-the-hole (FITH) abort test/first ascent propulsion system (APS) burn
- 8) Orbital coast to second APS burn
- 9) Second APS burn
- 10) Orbital coast to third APS burn
- 11) Third APS burn
- 12) Orbital cold-soak to fourth APS burn
- 13) Fourth APS burn
- 14) Final orbital coast

The Saturn IB launch phase includes the thrusting phases of the S-IB and S-IVB stages. The boilerplate command and service module (CSM) is jettisoned during S-IVB thrusting by the launch escape subsystem (LES). S-IVB thrust termination occurs at a radius vector magnitude of approximately 21,440,000 feet (perigee altitude of approximately 85 nautical miles) and a zero-degree inertial flight path angle. The velocity at insertion is such that the radius vector magnitude at apogee is approxi-

mately 21,650,000 feet (altitude of approximately 120 nautical miles). These data correspond to the insertion state vector furnished to MSC by MSFC through the Guidance and Performance Subpanel (Reference 3).

The spacecraft is separated from the S-IVB/SLA combination during the first revolution by the LEM/reaction control system (RCS) thrusters. MSFN coverage of this mission event is provided by the Australia Apollo tracking ship.

The first DPS burn is performed on the third revolution following a spacecraft attitude-hold thermal soak (LEM X axis normal to the ecliptic plane and Z axis toward the sun) of approximately 3 hours. The "Hohmann descent" guidance philosophy is used for the first DPS burn. During this burn (approximately 39 seconds), the  $\Delta V$  available (approximately 150 feet per second) is used to raise the apogee altitude to approximately 180 nautical miles.

The second DPS burn/FITH abort test/first APS burn maneuver is performed across the United States during the latter part of the third revolution and the first part of the fourth revolution. The "lunar landing" guidance philosophy is used for the second DPS burn (excluding the random throttling phase). The major portion of the  $\Delta V$  available (approximately 7000 feet per second) from this 757-second burn is dissipated out of the orbit plane. The approximate apogee and perigee altitudes following the random throttling sequence are 200 nautical miles and 155 nautical miles, respectively.

FITH staging and the first APS burn are accomplished in a constant inertial attitude mode. The spacecraft attitude during the 5-second APS burn dissipates most of the available  $\Delta V$  (approximately 55 feet per second) out of the orbit plane. The spacecraft orbit following this burn is essentially unchanged from the orbit following the second DPS burn.

The second APS burn is performed over the United States near the end of the fourth revolution. The "LEM ascent" guidance philosophy is used for the second APS burn. Most of the available  $\Delta V$  (approximately 5200 feet per second) resulting from this 395-second burn is dissipated

out of the orbit plane. At shutdown of the second APS burn, the spacecraft is on an orbit defined by an apogee altitude of approximately 203 nautical miles and a perigee altitude of approximately 163 nautical miles. Following this mission event, and an attitude-hold orbital coast of approximately 45 minutes, the third APS burn is performed while in sight of the Carnarvon-MSFN station. During the constant-attitude 5-second third APS burn, the spacecraft thrust vector is oriented such that the orbit perigee altitude is reduced to approximately 149 nautical miles. Approximately 100 feet per second of  $\Delta V$  is available from this burn.

The fourth APS burn is performed during the latter part of the seventh revolution over the United States following an attitude-hold thermal soak (LEM X axis normal to the ecliptic plane and Z axis toward the sun) of approximately 3.5 hours. During the fourth APS burn (approximately 8 seconds), the spacecraft attitude is maintained in an attitude-hold mode by the abort guidance subsystem. The  $\Delta V$  available from this burn (approximately 160 feet per second) is used to decrease the spacecraft perigee altitude to approximately 125 nautical miles.

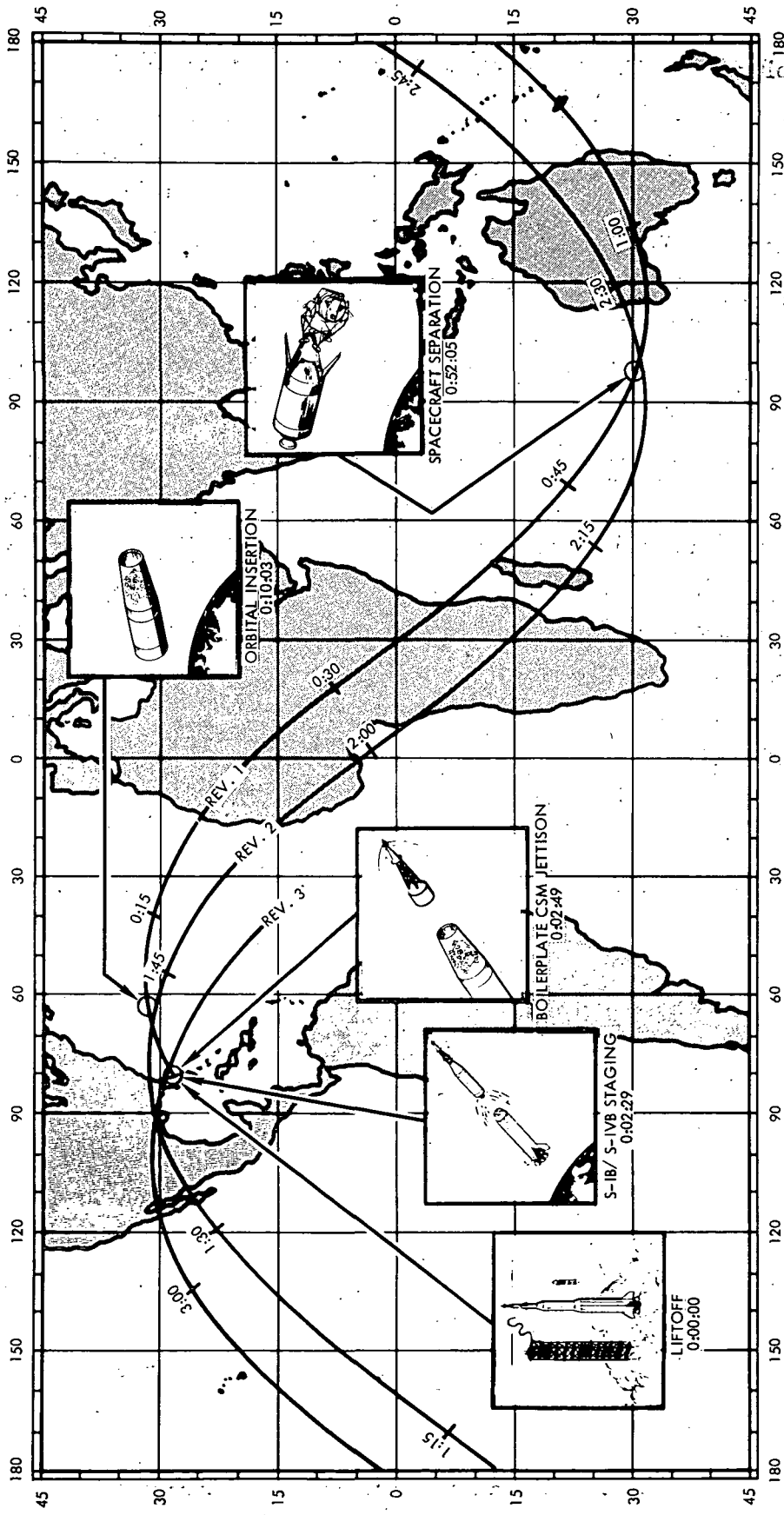

Figure 1-1. Mission Profile Summary



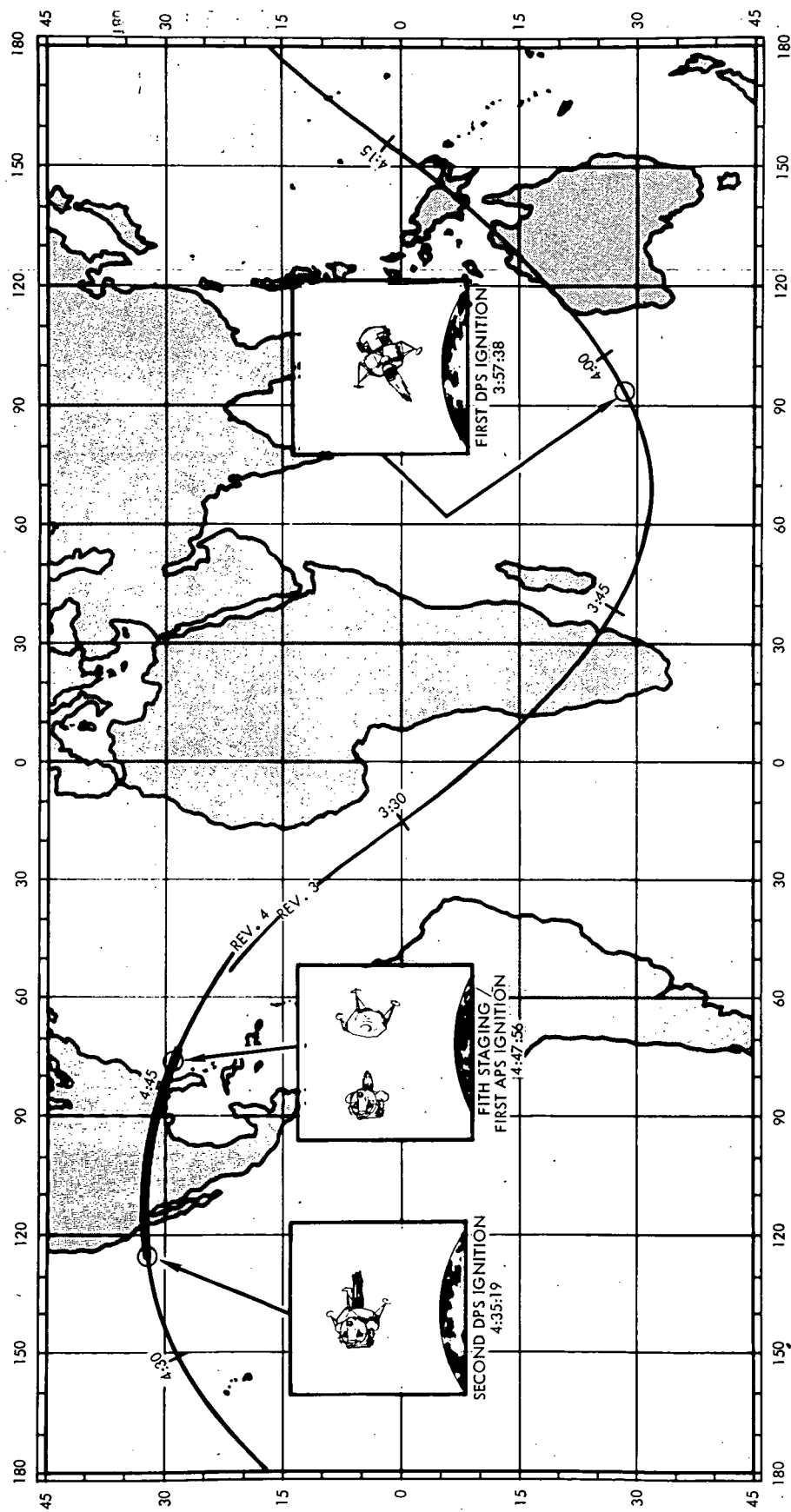

Figure 1-1-1. Mission Profile Summary (Continued)

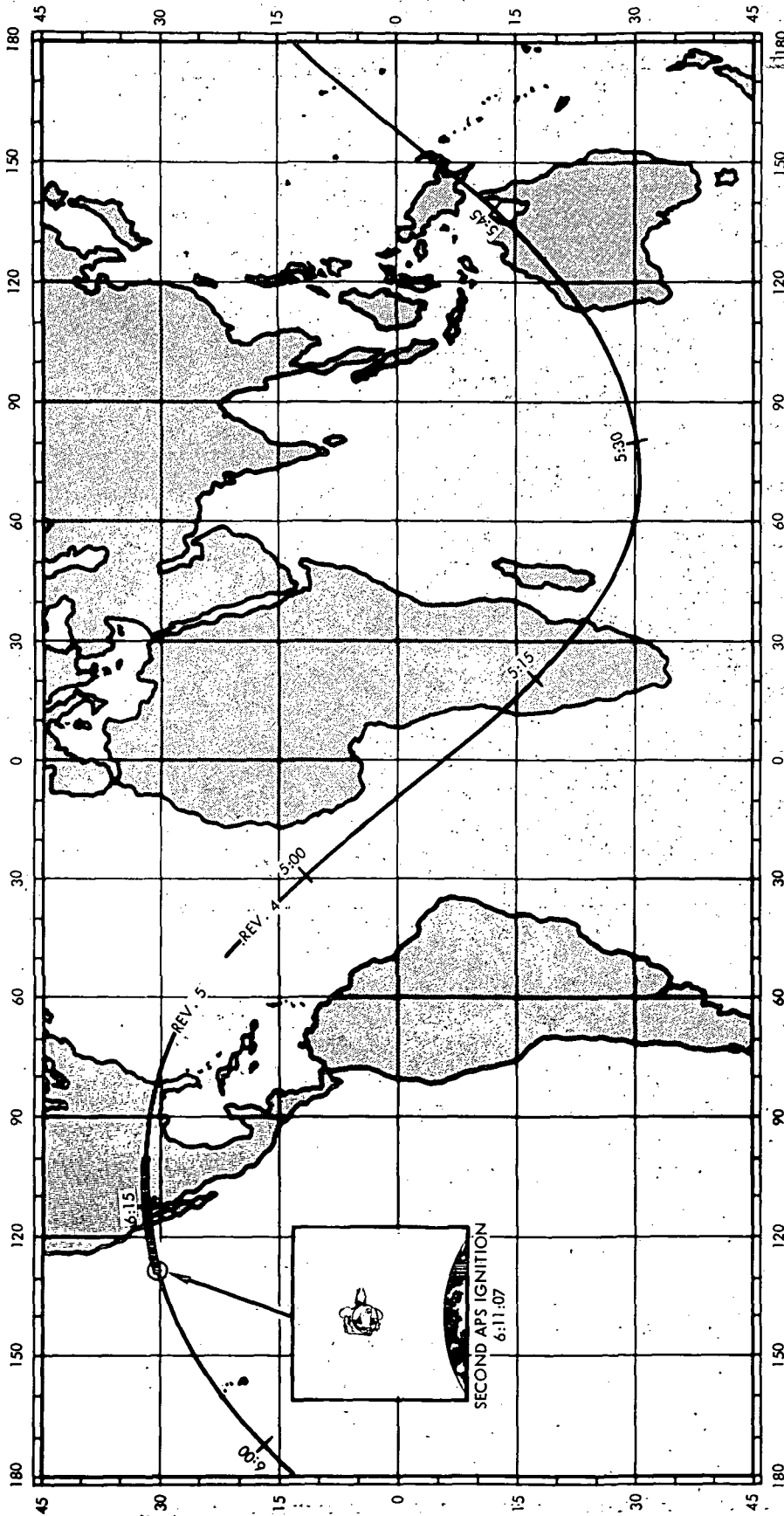

Figure 1-1. Mission Profile Summary (Continued)

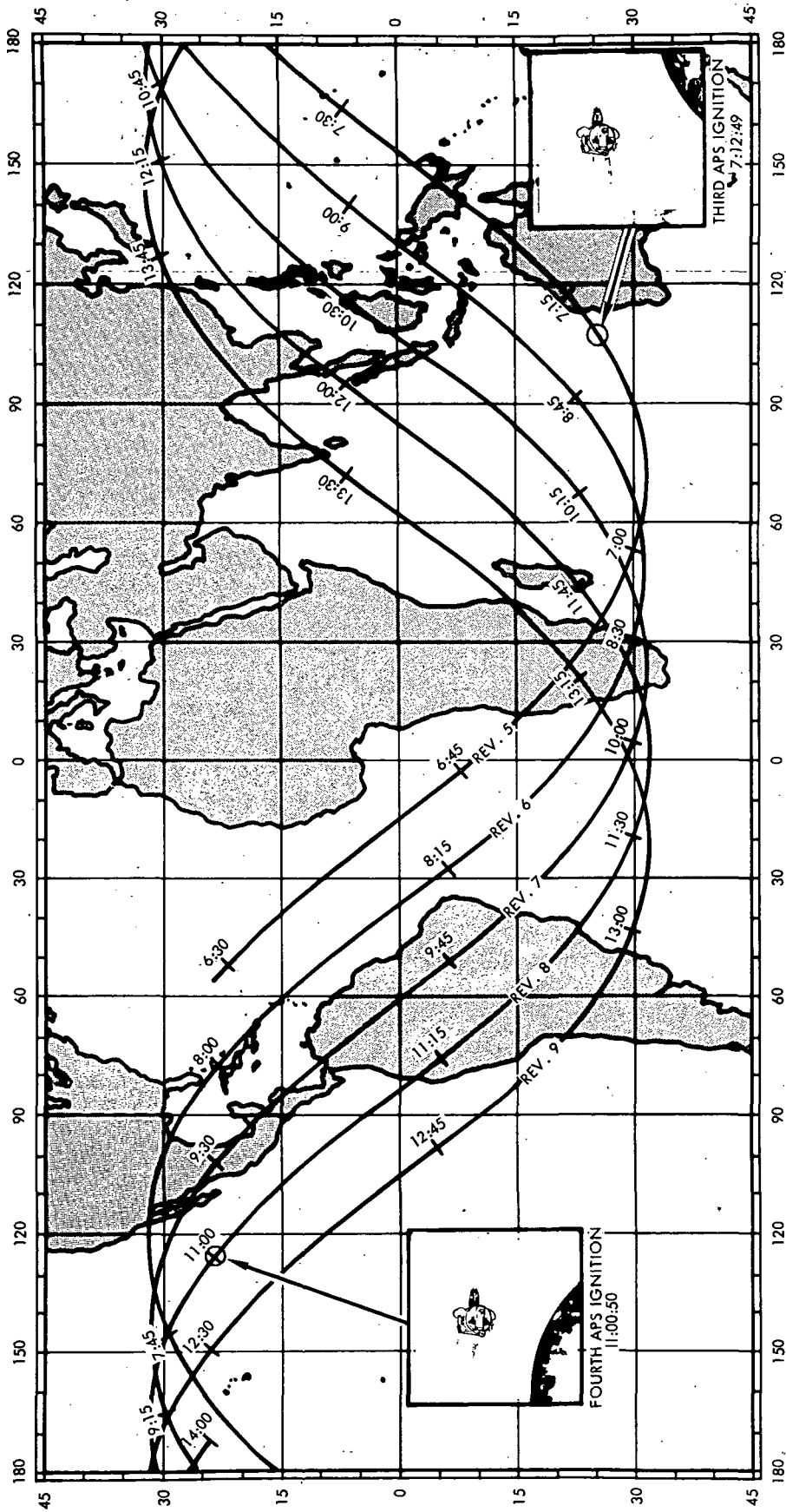

Figure 1-1. Mission Profile Summary (Continued)

## 2. SPACECRAFT MISSION REQUIREMENTS

### 2.1 SPACECRAFT TEST OBJECTIVES

The purpose of Apollo mission AS-206A is to conduct an unmanned test of an operational LEM for verification of subsystems operations. The spacecraft test objectives are summarized in this section and presented in Reference 1.

#### 2.1.1 Primary Spacecraft Test Objectives

- a) Verify operation of the following LEM subsystems: primary navigation and guidance control system (PNGCS), RCS, APS, and DPS.
- b) Evaluate FITH abort test.

#### 2.1.2 Secondary Spacecraft Test Objectives

- a) Demonstrate APS operation at low propellant quantities.
- b) Demonstrate operation of the mission programmer.

### 2.2 MISSION PROFILE GUIDELINES

The mission profile guidelines have been compiled from References 1, 4 through 8, and supplemented by data furnished by the Manned Spacecraft Center (MSC) at technical coordination meetings.

#### 2.2.1 Launch Vehicle Guidelines

- a) The nominal flight azimuth shall be 72 degrees from true North.
- b) The LES will be utilized to jettison the boilerplate CSM from the S-IVB/SLA/LEM combination when the dynamic pressure has decreased to less than one pound per square foot.
- c) The guidance command angular rate limitation shall be one degree per second for both pitch and yaw steering.

#### 2.2.2 MSFN Coverage/Flight Control Guidelines

- a) Continuous MSFN tracking, telemetry, and ground command backup coverage are required from liftoff to S-IVB thrust termination (orbital insertion) plus 3 minutes.

- b) Continuous telemetry, tracking, and ground command backup coverage are required for all LEM descent and ascent stage firings and pre-ignition attitude maneuvers. This coverage should commence at least 2 minutes prior to the programmed ignition and should not end prior to confirmation of shutdown.
- c) Telemetry and tracking coverage are required at least once per revolution during orbital coasts and thermal soaks.
- d) Telemetry, tracking, and ground command backup coverage are required at least 3 minutes prior to spacecraft separation. This coverage should continue until the LEM can radiate to a MSFN station.
- e) State vector update capability is required near the Carnarvon MSFN station.
- f) For mission events requiring command coverage by more than one MSFN station, it is desired that the coverage overlap be at least 30 seconds.
- g) The FITH abort test/first APS burn shall be performed at an orbital position so that at least three MSFN stations with data record capability can receive data from this demonstration.
- h) The LEM very high frequency (VHF) slant range acquisition limit is approximately 740 nautical miles.

### 2.2.3 LEM Attitude Guidelines

- a) Shortly after orbital insertion, the S-IVB/SLA/LEM combination shall be maneuvered such that the X axis lies in the plane of the local horizontal and the minus Z axis is directed downward along the local vertical. This attitude shall be maintained in an orbital rate mode until the start of the separation sequence to enhance communications.
- b) A  $\pm 0.3$ -degree deadband attitude-hold mode shall be maintained during the separation sequence.
- c) Shortly after separation from the SLA, the LEM shall be oriented such that the X axis is aligned to within  $\pm 15$  degrees of a normal to the ecliptic plane and the plus Z axis is directed toward the sun. This attitude shall be maintained for approximately 3 hours for thermal soak of the DPS injector face.
- d) During coast periods when the LEM attitude is not otherwise constrained, the minus Z axis shall be

directed downward along the local radius vector to enhance communications and to provide backup for VHF pulse code modulation (PCM) telemetry.

- e) All orbital coasts requiring specific orientations shall be maintained in the  $\pm 5$ -degree deadband attitude-hold mode.
- f) Shortly after the third APS burn, the LEM shall be oriented such that the X axis is aligned to within  $\pm 15$  degrees of a normal to the ecliptic plane and the Z axis is directed toward the sun for thermal soak of the APS injector face and RCS quad III. This attitude shall be maintained for approximately 3 hours.

#### 2.2.4 LEM Propulsion Guidelines

- a) LEM separation from the S-IVB/SLA combination shall be accomplished during the first revolution using four RCS thrusters firing for 18 seconds to provide plus X axis translation. The LEM/SLA restraining straps shall be severed 2 seconds after RCS ignition. This RCS firing time provides adequate clearance between the stowed landing gear and the SLA petals should one of the RCS engines fail to fire.
- b) Ullage settling maneuvers shall precede all DPS firings using four RCS thrusters to provide plus X axis translation. These ullage maneuvers shall be 6 seconds in duration.
- c) Ullage settling maneuvers shall precede the second, third, and fourth APS firings using four RCS thrusters to provide plus X axis translation. These ullage settling maneuvers shall be 2.5 seconds in duration.
- d) The start sequence of each DPS burn shall be as follows: ignition and the first 3 seconds of the burn shall be at the 30-percent thrust setting; the next 23 seconds shall be at the 10-percent thrust setting.
- e) The first DPS burn profile shall consist of the start sequence described in the above paragraph followed by approximately 7 seconds of thrusting at the 92.5-percent thrust setting. Shutdown of the first DPS burn shall occur approximately 33 seconds after ignition.
- f) The second DPS burn profile shall consist of the start sequence previously described followed by 379 seconds at the 92.5-percent thrust setting; for the next 300 seconds, the thrust shall decrease linearly from the 60- to the 10-percent thrust

setting. The random throttling portion of the burn shall begin following the thrust decay to the 10-percent thrust setting and shall be 52 seconds in duration. The random throttling profile shall consist of 10-second intervals at the 10-, 50-, 30-, 40-, and 20-percent thrust settings followed by a 2-second burn at the 92.5-percent thrust setting.

- g) The FITH abort test is to be initiated immediately after the 92.5-percent thrust setting of the random throttling phase.
- h) The first APS burn (initiated with the FITH abort test) shall be approximately 5 seconds in duration.
- i) The second APS burn shall be approximately 435 seconds in duration.
- j) The third APS burn shall occur approximately 45 minutes after shutdown of the second APS burn.
- k) The third and fourth APS burns shall be approximately 5 seconds in duration.
- l) Demonstration of RCS operation with propellant transferred from the APS tanks shall begin 2 seconds after the start of the second APS burn and will continue until shutdown.
- m) The fourth APS burn duration shall deplete the APS propellants to less than 5 percent of the total available.

#### 2. 2. 5 General Mission Guidelines

- a) The predicted orbital lifetime for the spent descent and ascent stages should not exceed 3 months.
- b) LEM separation from the S-IVB/SLA shall occur during the first revolution in the vicinity of the Carnarvon MSFN station.
- c) LEM landing gear deployment shall occur following the orbital cold-soak prior to the first DPS burn while the spacecraft is in contact with a MSFN station.
- d) Pre-ignition attitude orientation maneuvers shall occur within MSFN coverage by a station with command backup capability.
- e) The fourth APS burn will be guided by the abort guidance subsystem (AGS) in the attitude-hold mode.

### 3. SUMMARY OF INPUT DATA

The input data contained in this section include the pertinent MSFN station specifications and the unclassified quantitative description of the spacecraft. The spacecraft specifications classified as confidential can be found in Volume II of this report. These data form the basis for the spacecraft reference trajectory in support of Apollo Mission AS-206A.

#### 3.1 SATURN IB LAUNCH VEHICLE

The Saturn IB launch vehicle which will be used to insert the S-IVB/SLA/LEM combination into the initial orbit is comprised of the S-IB and S-IVB stages. The official launch vehicle data and launch vehicle reference trajectory (Reference 9) will be furnished by Marshall Space Flight Center (MSFC). The Saturn IB launch vehicle is illustrated in Figure 3-1.

#### 3.2 SPACECRAFT (LEM-1)

The spacecraft weight statement was obtained from Reference 8 and is presented in Volume II of this report. The propulsion characteristics for both the ascent and descent stages of the spacecraft are presented in Volume II of this report. The spacecraft reference dimensions are presented in Figure 3-2. The LEM-1 outboard profile is illustrated in Figure 3-3.

#### 3.3 MSFN STATIONS

The locations and capabilities of the MSFN stations that are planned to be available for support of Apollo Mission AS-206A were obtained from References 5 and 10, respectively. These data are summarized in Table 3-1. The station coordinates given are based on the Fischer ellipsoid model described by an equatorial earth radius of 6,378,166.0 meters, a polar earth radius of 6,356,784.284 meters, and an earth flattening ratio of 1/298.3. MSFN station altitudes are referenced to this ellipsoid and include any known geoidal separation.

The criteria for selecting the locations of the three Apollo tracking ships which are listed in Table 3-1 are discussed in the following paragraphs. The Australia Apollo tracking ship (Ship Number One) is planned for location off the western coast of Australia. The coverage afforded by



the Carnarvon tracking station and this tracking ship will be used for the spacecraft separation sequence, state vector updates, the first DPS burn, and the third APS burn. The location of this ship is such that the 30-second coverage overlap requirement between this station and Carnarvon and the 3 minutes of coverage prior to separation requirement are satisfied. This location also provides at least 2 minutes of coverage prior to the first DPS burn and the third APS burn. Summaries of the study data used in the selection of the location of this ship are illustrated in Figures 3-4 and 3-5.

The California Apollo tracking ship (Ship Number Two) is to be located off the western coast of the continental United States. Coverage provided by this station is required for the second DPS burn and the second and fourth APS burns. Because of the large central angle traversed by the spacecraft during the second DPS burn, it was required that the location of this ship be positioned to increase coverage for this mission event, yet provide the necessary coverage for the second and fourth APS burns. To satisfy these requirements, this station was located as far off the western coast of the United States as possible, while still retaining a 30-second coverage overlap with the Texas MSFN station.

The Bermuda Apollo tracking ship (Ship Number Three) is located so that it provides coverage from 30 seconds prior to S-IVB shutdown (orbital insertion) to at least 3 minutes after S-IVB shutdown. A summary of the study data used in the selection of the position of this ship is presented in Figure 3-6. The data presented in Figure 3-6 may also be used to adjust the position of this ship and to determine the location of any additional coverage sources which may be required for support of possible contingency situations.

#### 3.4 EARTH CONSTANTS AND CONVERSION FACTORS

The earth constants and conversion factors presented on the following page were extracted from Reference 4 and have been used in the generation of the spacecraft reference trajectory.

### 3. 4. 1 Earth Constants

Rotational rate	$4.37526902 \times 10^{-3}$ rad/min
	$0.417807416 \times 10^{-2}$ deg/sec
	$0.729211504 \times 10^{-4}$ rad/sec
Equatorial radius	$2.092573819 \times 10^7$ ft
Average radius	$2.0909841 \times 10^7$ ft
Gravitational parameter ( $\mu_e$ )	$5.53039344 \times 10^{-3}$ er <sup>3</sup> /min <sup>2</sup>
	$11.46782384 \times 10^3$ er <sup>3</sup> /day <sup>2</sup>
	$3.986032 \times 10^5$ km <sup>3</sup> /sec <sup>2</sup>
	$1.407653916 \times 10^{16}$ ft <sup>3</sup> /sec <sup>2</sup>
Coefficients of potential harmonics	
J term (second)	$1.62345 \times 10^{-3}$ nd
H term (third)	$-0.575 \times 10^{-5}$ nd
D term (fourth)	$0.7875 \times 10^{-5}$ nd
Earth flattening	1/298.3 nd

### 3. 4. 2 Conversion Factors

Kilometers per foot	$0.3048 \times 10^{-3}$ km/ft
Kilometers per nautical mile	1.852 km/n mi
Feet per nautical mile	6076.115486 ft/n mi
Weight-to-mass ratio	32.17404856 lb/slug
Mass-to-weight ratio	0.031080950 slug/lb
Feet per earth equatorial radius	$2.092573819 \times 10^7$ ft/er
Nautical miles per earth equatorial radius	3443.93358 n mi/er

### 3.5 SPACECRAFT AND ATTITUDE REFERENCE COORDINATE SYSTEMS

The spacecraft and attitude reference coordinate systems are illustrated in Figures 3-7 through 3-9. The spacecraft attitude is measured by the pitch, yaw, and roll angles required to rotate from the reference system to the current spacecraft orientation.

#### 3.5.1 Spacecraft Coordinate System, $\bar{X}_S, \bar{Y}_S, \bar{Z}_S$

The LEM coordinate system (see Figure 3-7) is an orthogonal, right-handed system coincident with the spacecraft axes. The  $\bar{X}_S$  axis extends through the upper docking tunnel. The  $\bar{Z}_S$  axis extends along the crew line-of-sight and the  $\bar{Y}_S$  axis completes the right-handed system.

#### 3.5.2 Launch Site Inertial Reference System, $\bar{X}_I, \bar{Y}_I, \bar{Z}_I$

This orthogonal, right-handed coordinate reference system (see Figure 3-8) coincides with the launch site at the time of launch. The  $\bar{X}_I$  axis extends downrange in the direction of the launch azimuth. The  $\bar{Z}_I$  axis extends upward along the astronomical vertical and the  $\bar{Y}_I$  axis completes the right-handed system.

#### 3.5.3 Launch Site Rotating Reference System, $\bar{X}_R, \bar{Y}_R, \bar{Z}_R$

This coordinate reference system (see Figure 3-8), which rotates with the earth, is coincident with the  $\bar{X}_I, \bar{Y}_I, \bar{Z}_I$  system at launch.

#### 3.5.4 Relative Vehicle Coordinate System, $\bar{X}_{RV}, \bar{Y}_{RV}, \bar{Z}_{RV}$

This coordinate system (see Figure 3-9) is an orthogonal, right-handed system centered at the primary vehicle. The  $\bar{X}_{RV}$  axis extends in the direction of motion. The  $\bar{Y}_{RV}$  axis extends upward along the primary vehicle position vector. The  $\bar{Z}_{RV}$  axis completes the right-handed system.

Table 3-1. MSFN Ground Stations and Capabilities

Station	Call Letters	VHF Telemetry			Station Capability			Geodetic			
		Record	Real Time	High Speed	C-Band Tracking		UHF Command	Unified S-Band	Latitude (1)	Longitude (1)	Altitude (2)
					Low Speed	Remoted					
Cape Kennedy	CNV	Yes	Yes	Yes	Yes	Yes	Yes	28.481767	-80.576514	45.9	
Eglin AFB	EGL	Yes	No	No	Yes	No	No	30.421767	-86.798114	91.9	
Grand Turk	GTI	Yes	Yes	Yes	Yes	No	No	21.462908	-71.132043	82.0	
Bermuda	BDA	Yes	Yes	Yes	Yes	Yes	Yes	32.347766	-64.653643	9.8	
Antigua	ANT	Yes	Yes	Yes	Yes	Yes	No	17.143796	-61.792683	85.3	
Grand Canary	CYI	Yes	Yes	No	Yes	Yes	No	27.735522	-15.60000	95.1	
Ascension	ASC	Yes	Yes	No	Yes	No	Yes	-7.972994	-14.401694	469.2	
Pretoria	PRE	Yes	No	No	Yes	No	No	-25.945553	28.361996	5334.6	
Carnarvon	GRO	Yes	Yes	No	Yes	Yes	Yes	-24.897356	113.716067	210.0	
Canberra	CAN	Yes	No	No	No	No	Yes	-35.3115277	149.1358333	164.0	
Guam	GUA	Yes	Yes	No	No	No	Yes	13.583333	144.924999	65.6	
Tanarive	TAN	Yes	No	No	No	No	Yes	-19.0183	47.3067	4363.5	
Hawaii	HAW	Yes	Yes	No	Yes	Yes	Yes	22.125267	-159.667619	3746.7	
Pt. Arguello	CAL	Yes	No	Yes	No	No	Yes	34.582902	-120.561149	2119.4	
Goldstone	ODS	Yes	No	No	No	No	Yes	35.389638	-116.848776	3382.5	
Guaymas	GYM	Yes	Yes	No	No	No	Yes	27.958405	-110.720791	59.0	
White Sands	WHS	Yes	No	Yes	No	No	No	32.358222	-106.369564	4042.0	
Texas	TEX	Yes	Yes	No	Yes	Yes	No	29.758610	-95.363582	164.0	
Grand Bahama	GBI	Yes	Yes	Yes	Yes	Yes	Yes	26.615786	-78.347849	45.9	
Australia Apollo Tracking Ship (Ship No. One)		Yes	Yes	Yes	No	Yes	No	-27.0	96.0	0	
California Apollo Tracking Ship (Ship No. Two)		Yes	Yes	Yes	No	Yes	No	31.0	-124.0	0	
Bermuda Apollo Tracking Ship (Ship No. Three)		Yes	Yes	Yes	No	Yes	No	31.91	-53.75	0	

(1) Minus coordinates specify south latitudes and west longitudes.  
 (2) Altitudes are above the Fischer reference ellipsoid.  
 (3) Data relayed directly to MCC (Houston).

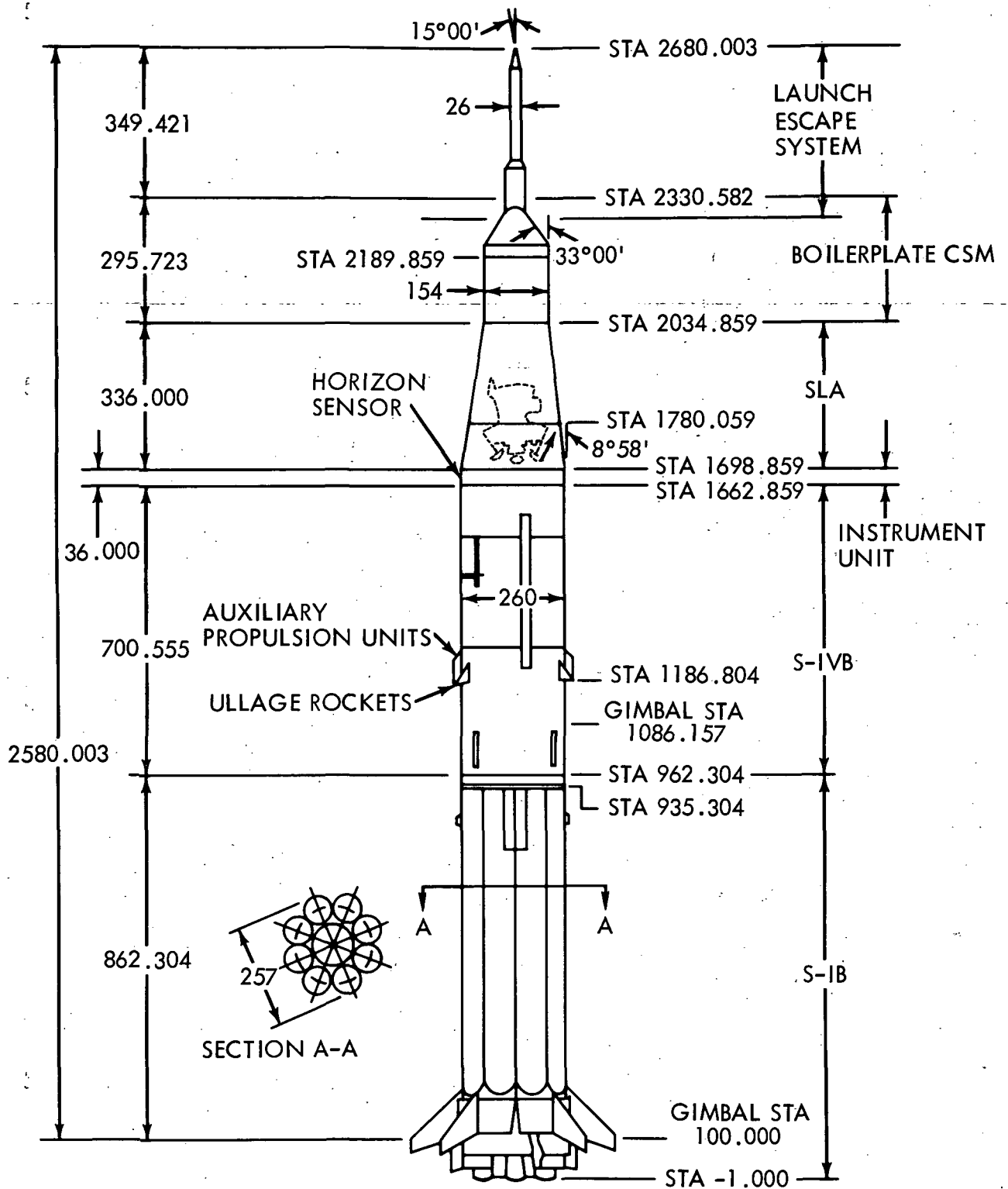

ALL VEHICLE STATIONS AND DIMENSIONS ARE IN INCHES

Figure 3-1. Saturn IB Launch Vehicle Outboard Profile

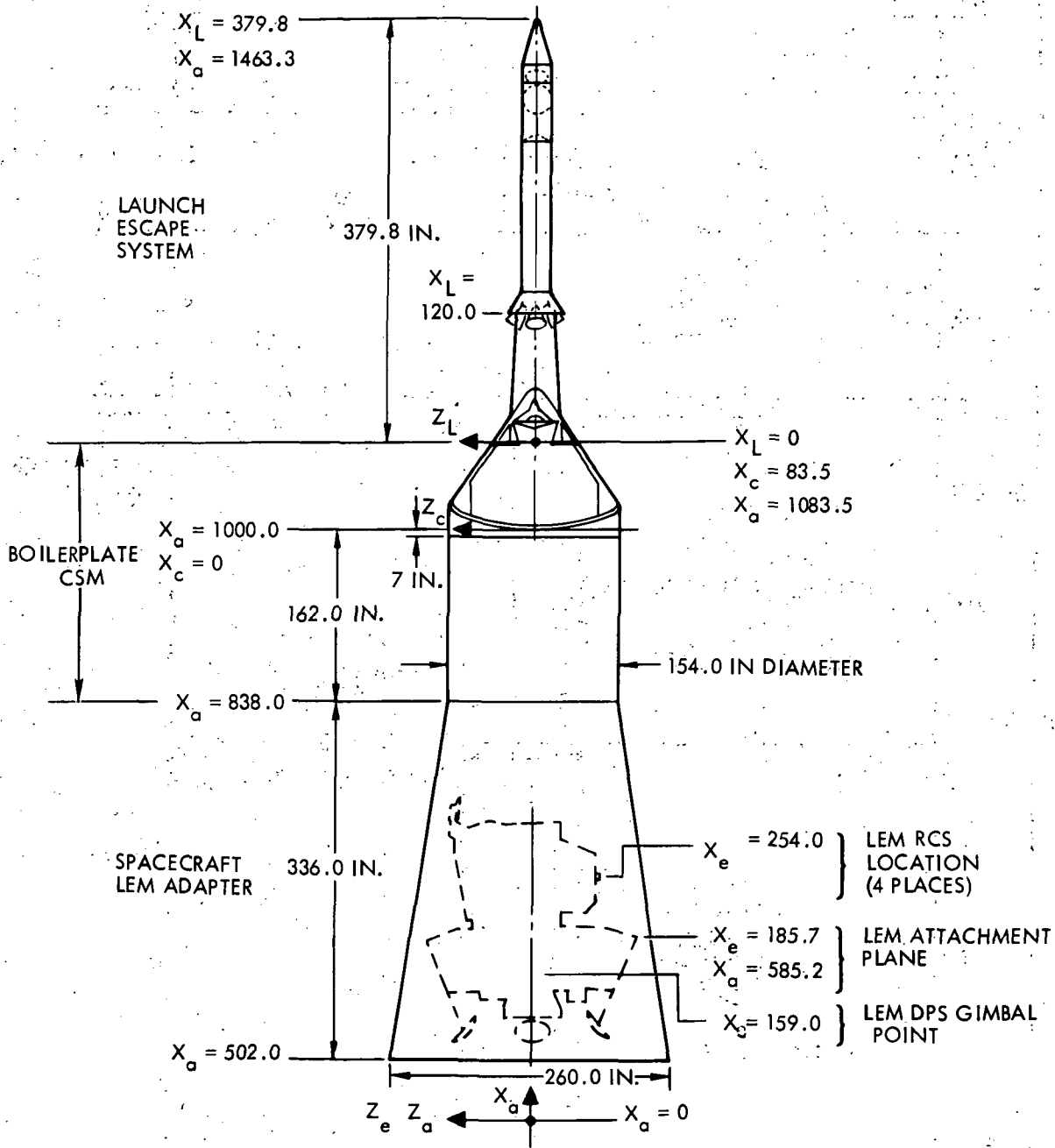

Figure 3-2. Spacecraft Reference Dimensions

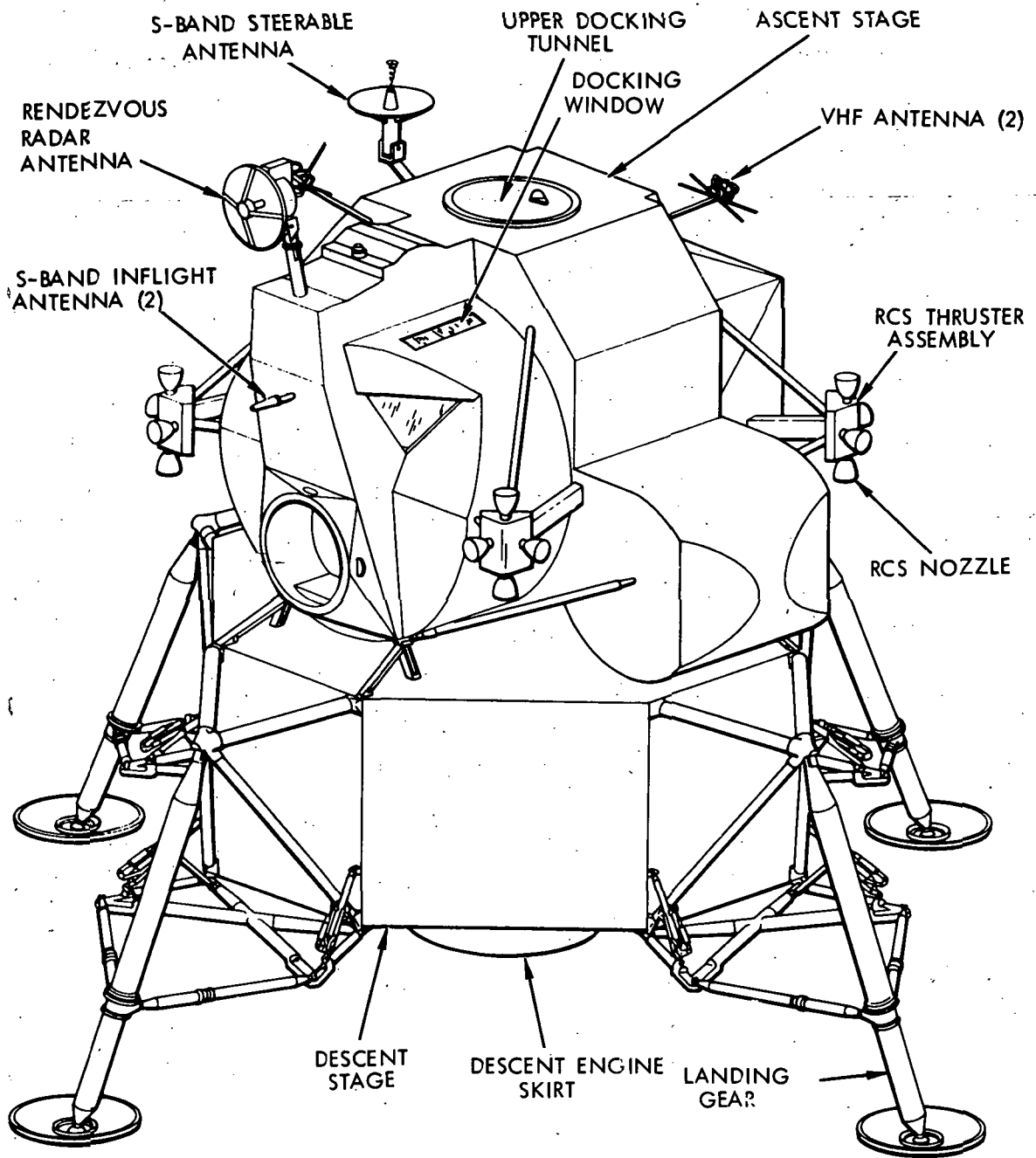

Figure 3-3. LEM-1 Outboard Profile

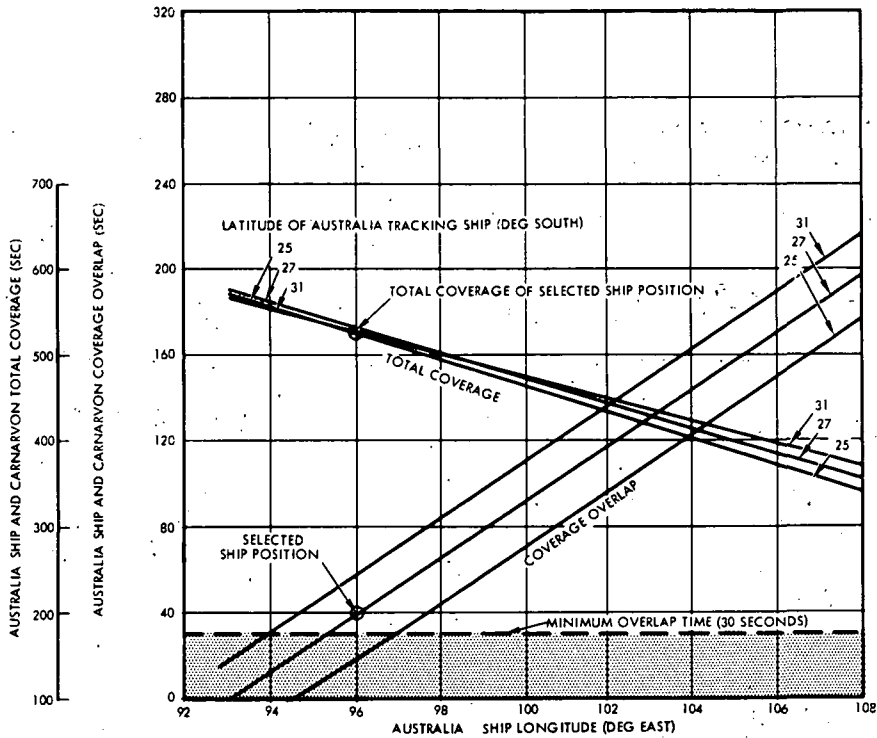

Figure 3-4. Australia Apollo Tracking Ship Placement Study/Spacecraft Separation

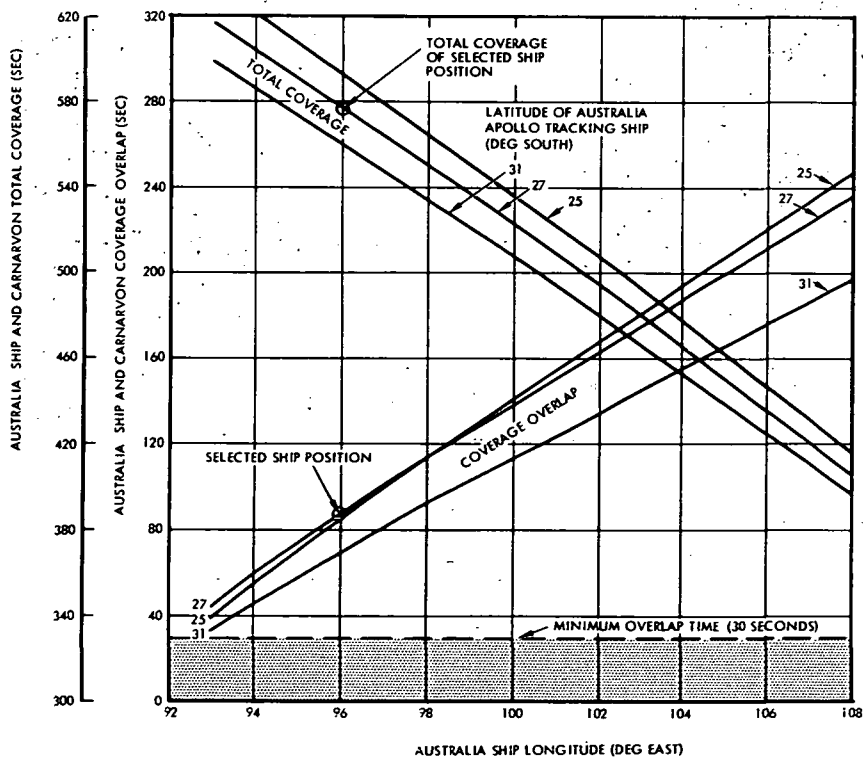

Figure 3-5. Australia Apollo Tracking Ship Placement Study/First DPS Burn



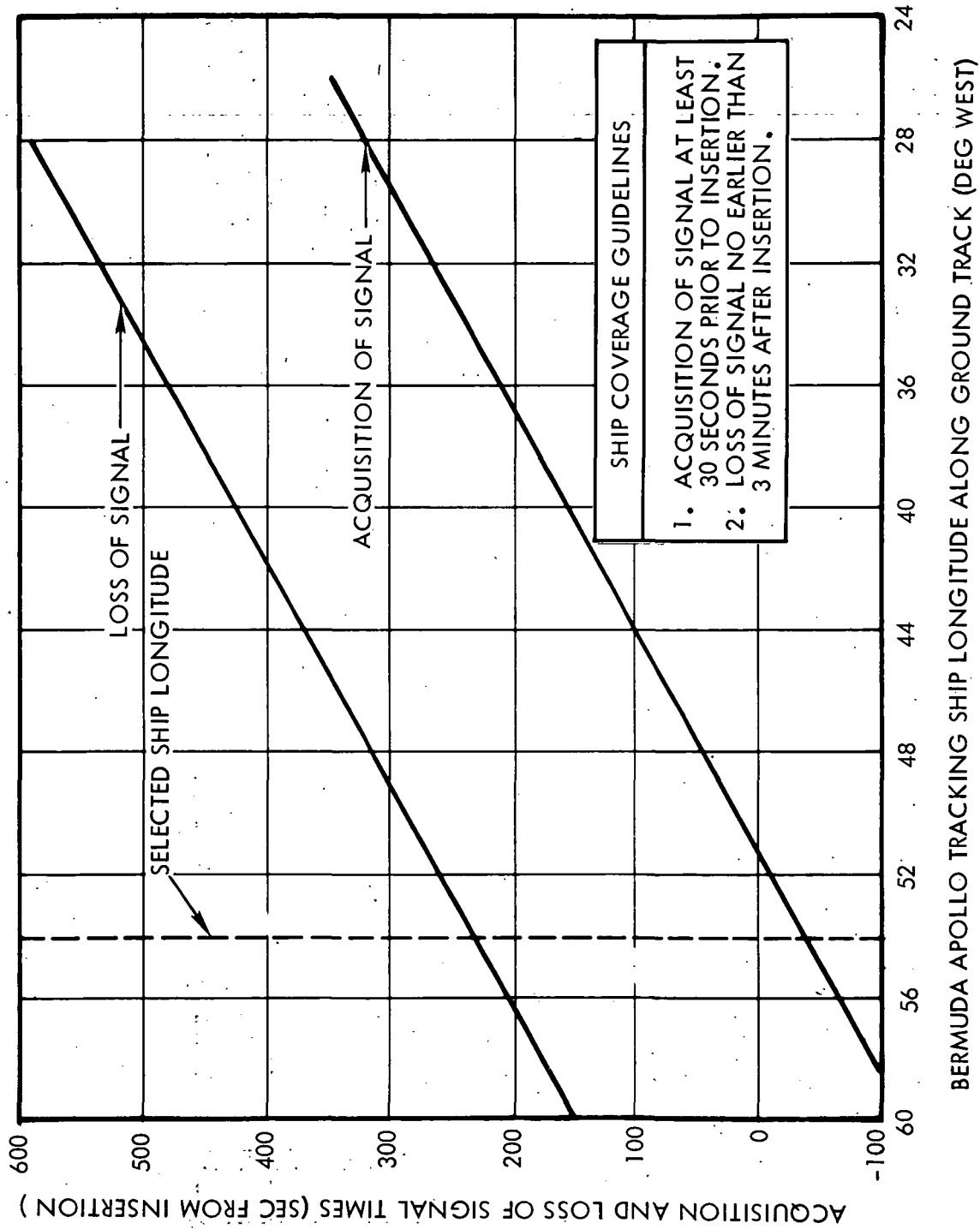

Figure 3-6. Bermuda Apollo Tracking Ship Placement Study

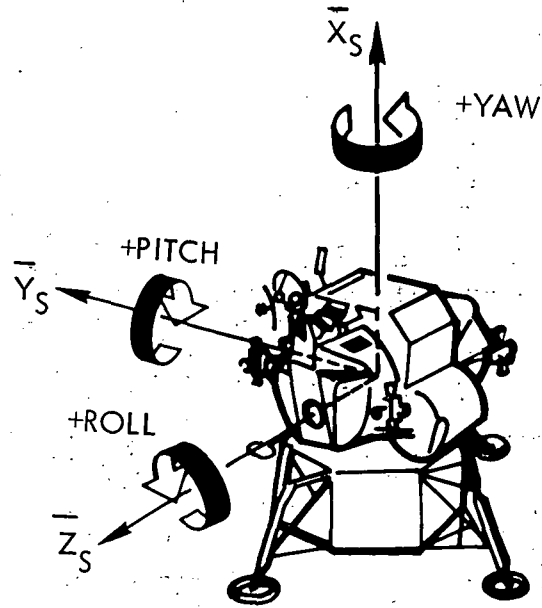

Figure 3-7. Spacecraft Coordinate System

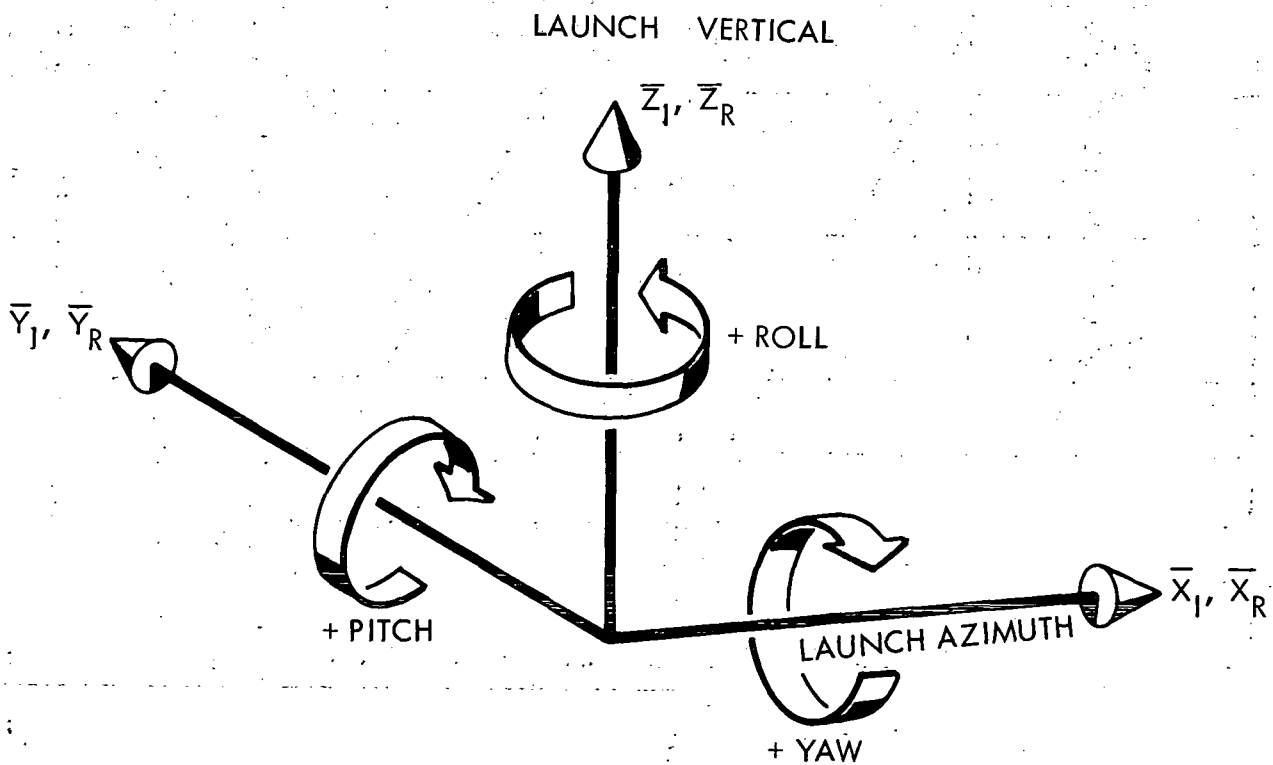

Figure 3-8. Reference Coordinate System

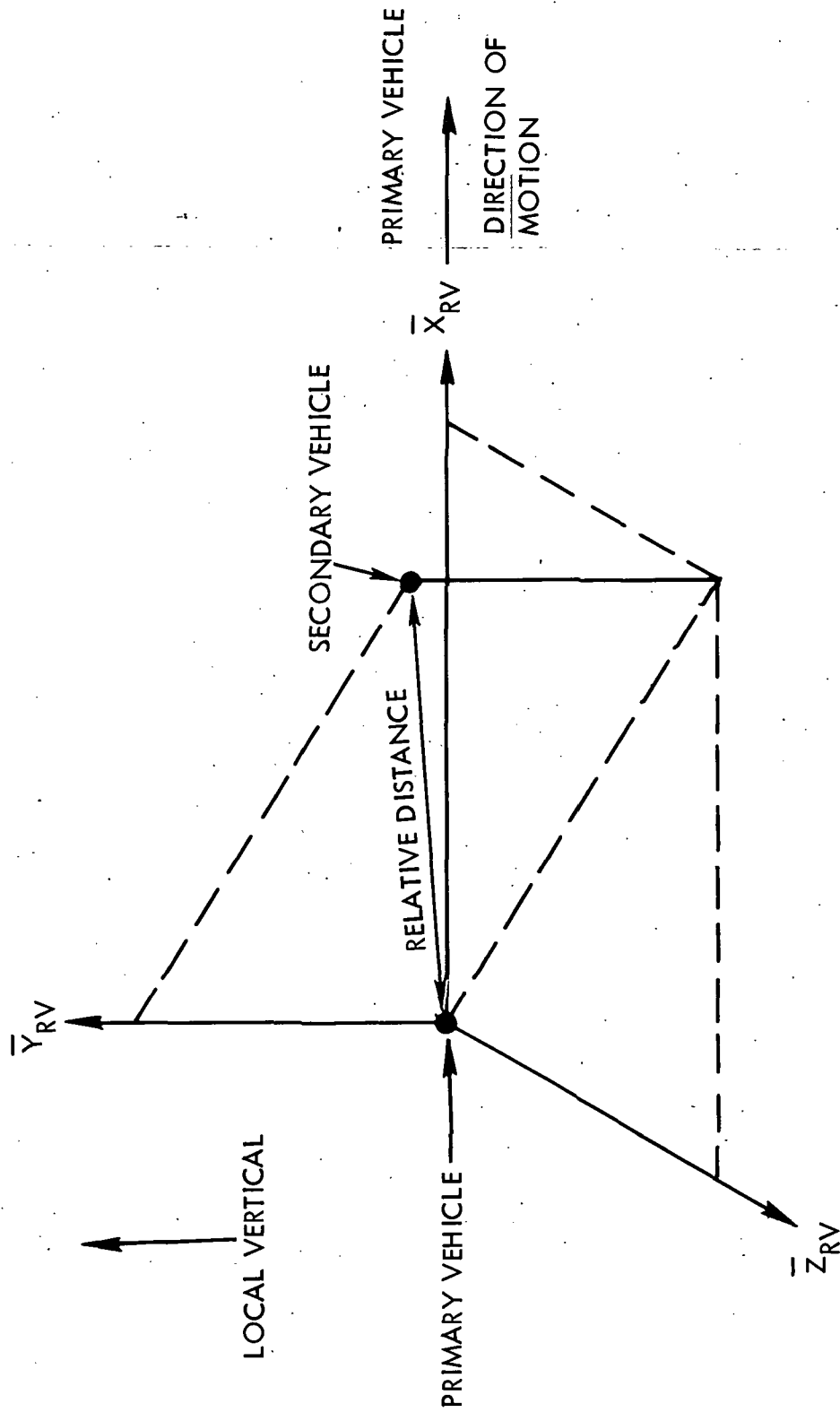

Figure 3-9. Relative Vehicle Coordinate System

## 4. MISSION DESCRIPTION

The spacecraft reference trajectory for Apollo Mission AS-206A has been designed to satisfy the mission test objectives (Reference 1) and known test requirements without violating the mission profile guidelines (Section 2.2). This mission profile uses the current LEM guidance philosophy for thrust vector and attitude control during the spacecraft first DPS, second DPS, and second APS burns. The spacecraft first, third, and fourth APS burns are accomplished in an attitude-hold mode. The description of the AS-206A mission simulation and the results of pertinent mission planning studies and mission analyses are presented in this section.

### 4.1 ASCENT-TO-ORBIT

Launch of Apollo Mission AS-206A is planned to occur from launch complex 37B of the Kennedy Spaceflight Center. For mission simulation purposes, launch is assumed to occur at 13:00 hours GMT (08:00 hours EST) on 1 April 1967.

The ascent-to-orbit profile presented in this report is based upon an MSFC trajectory listing transmitted to MSC through the Guidance and Performance Subpanel (Reference 3). The ascent-to-orbit phase of the mission profile utilizes a 72-degree flight azimuth from true North and includes the burn of the S-IB stage and the burn of the S-IVB stage. The boilerplate CSM is jettisoned when the dynamic pressure decreases to less than one pound per square foot.

Insertion into an elliptical earth orbit occurs 603.44 seconds after liftoff. The state vector at insertion is described as follows:

- Inertial velocity magnitude of 25,658 feet per second
- Radius vector magnitude of 21,440,000 feet (approximately 85 nautical miles)
- Inertial flight path angle of 0.0 degree
- Orbital plane inclination of 31.61 degrees.

The ascent-to-orbit phase presented in this report has been designed to satisfy the previously mentioned conditions. MSFN coverage is provided by the Cape Kennedy, Grand Bahama, Grand Turk, Bermuda, and the Bermuda Apollo tracking ship stations. It should be noted that the data for this mission phase are presented for completeness only; the official launch vehicle data will be published by MSFC in the launch vehicle reference trajectory (Reference 9).

#### 4.2 S-IVB/SLA/LEM ORBITAL COAST

Shortly after insertion into the initial orbit, the S-IVB/SLA/LEM combination is maneuvered so that the spacecraft X axis lies in the plane of the local horizontal and the minus Z axis is directed along the radius vector toward the earth. This attitude is maintained by the S-IVB in an orbital rate mode until 120 seconds prior to LEM separation to enhance LEM/MSFN communications. SLA petal deployment occurs during the first revolution (30 minutes after orbital insertion).

#### 4.3 SPACECRAFT SEPARATION

LEM separation from the S-IVB/SLA combination occurs near apogee during the first revolution, approximately 10 minutes after SLA petal deployment. The selection of the in-orbit position for this mission event is such that continuous MSFN ground command coverage is provided by the Australia Apollo tracking ship and the Carnarvon station. Sixty seconds after acquisition the S-IVB begins an attitude-hold maneuver, maintaining a constant inertial attitude through the spacecraft separation sequence. Two minutes after the beginning of the inertial attitude-hold period, four LEM/RCS thrusters are ignited to provide plus X axis translation. At RCS ignition, the spacecraft plus X axis is in the orbital plane approximately 9 degrees above the local horizontal. Two seconds after RCS ignition, the SLA/LEM restraining straps are severed and the LEM begins the withdrawal from the SLA. Eighteen seconds after ignition RCS thrusting is terminated. The separation characteristics (LEM-to-S-IVB relative velocity and distance) are presented in Figures 4-1 and 4-2. The total coverage provided by the two MSFN stations for this event is approximately 8 minutes and 40 seconds.

#### 4.4 ORBITAL COLD-SOAK TO FIRST DPS BURN

Ten seconds after shutdown of the four RCS engines in the spacecraft separation sequence, the LEM is commanded to perform an attitude maneuver to align the X axis normal to the ecliptic plane and to direct the Z axis toward the sun. The spacecraft maintains this inertial attitude in the  $\pm 5$ -degree deadband mode for the duration of the cold-soak (approximately 3 hours). The spacecraft attitude orientation during the cold-soak period is illustrated in Figure 4-3.

Since the sun's position relative to the spacecraft is dependent on the launch date and time, the maneuver included in this mission profile is valid only for the assumed launch date and time (13:00 hours GMT, 1 April 1967). The spacecraft inertial attitude angles which satisfy this thermal cold-soak requirement are presented in Figure 4-4 as a function of launch date and time for the second quarter of 1967.

#### 4.5 FIRST DPS BURN

Upon acquisition of tracking by the Australian tracking ship on the third revolution, an orientation maneuver is initiated to align the spacecraft axes to the desired orientation for the first DPS burn (see Figure 5-14). This maneuver is executed in the 5-degree per second rate mode. Shortly after the termination of this maneuver, the LEM landing gear is deployed. Approximately one minute has been provided prior to RCS ignition for MSFN verification of gear deployment.

The first DPS ignition is preceded by a 6-second RCS plus X axis translation for ullage settling. The first DPS burn start sequence consists of ignition and the first 3 seconds of burn time at the 30-percent thrust setting, followed by 23 seconds at the 10-percent thrust setting. This start sequence is followed by a one-second buildup to, and approximately 11.5 seconds at, the 92.5-percent thrust setting (see Figure 4-6).

The "Hohmann descent" LEM guidance philosophy is used to control the spacecraft attitude and attitude rates during this burn (Reference 11). This guidance philosophy is characterized by burnout at a zero-degree flight path angle.

At shutdown of the first DPS burn, the spacecraft is on an orbit defined by a predicted apogee altitude of 180 nautical miles, a predicted perigee altitude of 119 nautical miles, and an orbital period of 90 minutes. The orbit is inclined 31.62 degrees to the equator and the longitude at burnout (perigee) is 96.5 degrees east. The continuous MSFN ground command coverage of the first DPS burn is provided by the Australia tracking ship and the Carnarvon station. The total coverage time is approximately 9 minutes and 30 seconds.

It was determined that the second DPS burn would be the least sensitive to attitude errors if the line of apsides of the orbit following the first DPS burn would bisect the central angle traversed by the spacecraft during the second DPS burn. An orbit defined by a 120-nautical mile perigee and a 180-nautical mile apogee resulted in a first DPS burn duration which satisfied the mission guidelines and provided continuous MSFN command coverage during the first and second DPS burns.

#### 4.6 ORBITAL COAST TO SECOND DPS BURN

Following shutdown of the first DPS burn, the spacecraft begins an orbital coast of approximately 35 minutes. Shortly after the beginning of the coast, a LEM maneuver to orient the X axis in the plane of the local horizontal and the minus Z axis toward the geocenter is performed at the 5-degree per second attitude-rate mode. The spacecraft is oriented in this manner to enhance LEM/MSFN communications. This attitude is maintained in the  $\pm 5$ -degree attitude-hold mode.

#### 4.7 SECOND DPS BURN/FIFTH ABORT TEST/FIRST APS BURN

##### 4.7.1 Second DPS Burn

At a mission time of approximately 4 hours and 33 minutes the LEM begins an orientation maneuver to the desired inertial attitude (Figure 5-18) for the second DPS burn. The attitude maneuver is performed in the 5-degree per second rate mode. Approximately 70 seconds after the completion of the attitude orientation maneuver, a 6-second RCS maneuver is initiated to provide plus X axis translation for ullage settling immediately prior to DPS ignition. The desired thrust profile, for the second DPS burn (Figure 4-7), consists of the start sequence described in

Section 4.5, followed by a 379-second burn phase at the 92.5-percent thrust setting and a 300-second linear decay from the 60- to the 10-percent thrust setting. Upon completion of the linear decay, a 52-second random throttling sequence is initiated. This throttling profile consists of ten-second intervals at the 10-, 50-, 30-, 40-, and 20-percent thrust settings, respectively. The random throttling profile ends with a two-second burn at the 92.5-percent thrust setting. This burn profile is typical of the lunar landing mission maneuvers that may be performed from the completion of lunar de-orbit to lunar touchdown.

The guidance philosophy used to provide control of the second DPS burn thrust vector magnitude and direction utilizes multiple targeting conditions (Reference 11). Each targeting condition consists of the desired position, velocity, and acceleration vectors and the burn duration for the spacecraft to satisfy these conditions. It should be noted that the random throttling sequence, FITH staging, and the first APS burn are performed in an attitude-hold mode.

The second DPS thrust profile resulting from the guidance commands is compared to the desired profile (from the mission guidelines) in Figure 4-7.

At shutdown of the second DPS burn, the LEM is on an orbit with a predicted perigee altitude of 155 nautical miles, a predicted apogee altitude of 200 nautical miles, a period of approximately 90.9 minutes, and an orbital inclination of approximately 30.5 degrees. An open loop analysis to determine the effects of an assumed IMU drift (Reference 7) on various spacecraft orbit dimensions following the second DPS burn was performed. The data generated from this study are presented in Figure 4-8 and were used in the selection of the desired orbit dimensions following the second DPS burn.

The majority of the  $\Delta V$  available from this burn (approximately 7,000 feet per second) is dissipated out of the orbit plane. Approximately one-percent of the useable DPS propellant remain after the second DPS burn.



MSFN coverage of the second DPS burn is provided by the California Apollo tracking ship, Goldstone, Texas, Cape Kennedy, Guaymas, White Sands, Grand Bahama, Eglin, and Bermuda stations.

#### 4.7.2 FITH Abort Test/First APS Burn

The FITH abort test is initiated immediately at the completion of the random throttling phase of the second DPS burn with simultaneous LEM staging and APS ignition signals. The duration of the first APS burn is 5.24 seconds. The in-orbit position of this event has been selected such that MSFN ground command coverage and data record capability are furnished by the Cape Kennedy, Grand Turk, Bermuda, Grand Bahama, and Eglin stations. In the mission simulation, 1,180 pound-seconds of impulse were delivered to both the LEM ascent and descent stages at the APS ignition to simulate APS plume impingement effects. Separation characteristics for the ascent and spent descent stages are presented in Figures 4-9 and 4-10. At FITH staging, the spacecraft X axis is approximately normal to the orbital plane. At shutdown, the ascent stage is on an orbit defined by a predicted perigee altitude of 152.5 nautical miles, a predicted apogee altitude of 200.0 nautical miles, a period of approximately 90.9 minutes, and an inclination of approximately 30.5 degrees. The spent descent stage is left in an orbit with a predicted apogee altitude of 200.2 nautical miles, a predicted perigee altitude of 153.4 nautical miles, an inclination of approximately 30.5 degrees, and a period of 90.9 minutes. The maximum estimate of the lifetime of the spent descent stage is 49 days (see Table 4-2).

#### 4.8 ORBITAL COAST TO SECOND APS BURN

Shortly after the first APS burn, a LEM ascent stage attitude maneuver is initiated to align the X axis in the plane of the local horizontal and to direct the minus Z axis toward the geocenter. This maneuver is accomplished in the 5-degree per second maneuver mode. This orientation is maintained in the  $\pm 5$ -degree attitude-hold mode throughout this coast (approximately 1 hour and 20 minutes).

#### 4.9 SECOND APS BURN

Following acquisition by the California tracking ship during the

fourth revolution, an attitude maneuver is initiated to orient the LEM ascent stage to the desired ignition attitude (see Figure 5-22). This maneuver is performed in the 5-degree per second maneuver mode. Two minutes after the acquisition of tracking, the RCS thrusters are ignited for 2.5 seconds of plus X axis translation for ullage settling. Immediately after the 2.5-second RCS burn, the second APS burn is initiated.

The "LEM ascent" guidance philosophy is used to control the spacecraft attitude, attitude rates, and second APS burn duration. This philosophy is characterized by the use of a desired velocity vector at burnout and an intercept time. The burn duration is varied so that the velocity vector requirements are satisfied at the intercept time. The philosophy used to target this burn consisted of varying the intercept parameters such that the desired burn time (approximately 395 seconds) and orbital conditions were met. It was required that the second APS burn duration be reduced from that specified in Reference 1 (approximately 435 seconds) in order that sufficient propellants remain for the required third and fourth APS burns.

At shutdown of this burn, the spacecraft orbit is defined by a predicted apogee altitude of 203.1 nautical miles, a predicted perigee altitude of 163.3 nautical miles, and a period of approximately 91.2 minutes. The orbital plane is inclined approximately 31.4 degrees to the equator. The desired orbit dimensions at second APS burn shutdown were chosen so that the orbital lifetime of the ascent stage could be significantly reduced during the third and fourth APS burns and to reduce the effects of the assumed IMU drift (Figure 4-10). Continuous MSFN coverage of this burn is furnished by the California Apollo tracking ship, the Texas, White Sands, Guaymas, Goldstone, and Point Arguello stations. The total coverage time is approximately 13 minutes.

Two seconds after initiation of the second APS burn, a test of RCS operation is initiated. This test is conducted to determine the operation of the RCS using propellants fed from the APS propellant tanks. The RCS is used for stabilization of the ascent stage during APS operation. This test is continued until shutdown of the second APS burn.

As in the second DPS burn, the majority of the  $\Delta V$  available during this burn (approximately 5,200 feet per second) is dissipated out of the orbit plane to maintain orbit dimension control.

#### 4. 10 ORBITAL COAST TO THIRD APS BURN

Shortly after shutdown of the second APS burn, the LEM is commanded to maneuver to the inertial attitude described in Section 4.8 at the 5-degree per second attitude maneuver mode. This attitude is maintained in the  $\pm 5$ -degree deadband mode until acquisition of tracking by the Australia tracking ship during the fifth revolution (approximately 53 minutes after shutdown of the second APS burn).

#### 4. 11 THIRD APS BURN

Upon acquisition of tracking by the Australia Apollo tracking ship, the LEM is commanded to maneuver to the desired ignition attitude for the third APS burn in the 5-degree per second attitude orientation mode. Two minutes after acquisition of tracking, a 2.5-second RCS maneuver is performed to provide plus X axis translation for ullage settling. Immediately after the ullage maneuver, the third APS burn (5.24 seconds in duration) is initiated. A constant inertial attitude was selected for this burn to decrease perigee altitude (thus orbital lifetime). This burn results in an orbit with an apogee altitude of approximately 220.1 nautical miles, a perigee altitude of approximately 149.4 nautical miles, a 91.2-minute period, and an orbit plane inclination of approximately 31.4 degrees. Approximately 10 minutes and 30 seconds of continuous MSFN coverage is furnished for this burn by the Carnarvon and Australia tracking ship stations.

#### 4. 12 ORBITAL COLD-SOAK TO FOURTH APS BURN

Shortly after completion of the third APS burn the LEM is maneuvered such that the X axis is normal to the ecliptic plane and the Z axis is directed toward the sun for cold-soak of the APS injector face. This maneuver is accomplished in the 5-degree per second attitude orientation mode. This attitude is maintained in the  $\pm 5$ -degree deadband mode for approximately 3 hours and 30 minutes.

#### 4. 13 FOURTH APS BURN

Following acquisition by the California tracking ship during the seventh revolution, an orientation maneuver is initiated in the 5-degree per second mode to align the spacecraft axes to the desired ignition attitude for the fourth APS burn. Two minutes after acquisition, 2.5 seconds of RCS thrusting is initiated to provide plus X axis translation for ullage settling. This is followed immediately by the fourth APS burn of approximately 8.2 seconds which depletes all of the available APS propellants with the exception of the one percent flight performance reserves.

The inertial attitude held during the APS burn further decreases the perigee attitude. At APS shutdown, the spent spacecraft is on an orbit characterized by a predicted perigee altitude of 124.8 nautical miles, a predicted apogee altitude of 199.0 nautical miles, an orbital period of approximately 90.4 minutes, and an orbital inclination of approximately 31.4 degrees. The estimated lifetime of the spacecraft in this orbit is approximately 19 days.

#### 4. 14 FINAL ORBITAL COAST

The majority of the mission objectives are completed at this phase of the mission; however, additional spacecraft tests may be scheduled after this time. An additional 3 hours have been added after the completion of the fourth APS burn to provide data for planning any additional spacecraft testing.

#### 4. 15 SPACECRAFT ORBITAL LIFETIME ESTIMATES

The estimated orbital lifetimes of the various LEM-1 configurations are presented in Table 4-2. The configurations which have been analyzed are defined below:

##### Configuration 1

The LEM-1 after separation from the S-IVB/SLA combination and prior to propulsion tests.

### Configuration 2

The spent descent stage after the FITH abort test.

### Configuration 3

The spent ascent stage after shutdown of the fourth APS burn.

Ballistic coefficients,  $W/C_D A$  (weight divided by the orbital drag coefficient and the frontal area), were calculated for each of the configurations. An orbital drag coefficient of 2.0 was assumed. Various configuration orientations were analyzed to determine the maximum and minimum frontal areas which each configuration could exhibit normal to the velocity vector. Table 4-1 presents the results of this analysis.

Table 4-1. Ballistic Coefficients

<u>Configuration</u>	<u>Area (ft<sup>2</sup>)</u>	<u>Weight (lb)</u>	<u><math>W/C_D A</math> (lb/ft<sup>2</sup>)</u>
1	* 200	33,475	83.69
2	(Maximum) 200	5,195	12.99
2	(Minimum) 80	5,195	32.47
3	(Maximum) 190	6,057	15.94
3	(Minimum) 125	6,057	24.23

\*The frontal area of the LEM does not change appreciably.

These ballistic coefficients, the applicable orbital characteristics, and information presented in Reference 10 were used to calculate the orbital lifetime estimates presented in Table 4-2.

Table 4-2. Spacecraft Orbital Lifetime Estimates

<u>Configuration</u>	<u>Orbital Lifetime (days)</u>	
	<u>Minimum</u>	<u>Maximum</u>
1	4	4
2	19	49
3	13	19

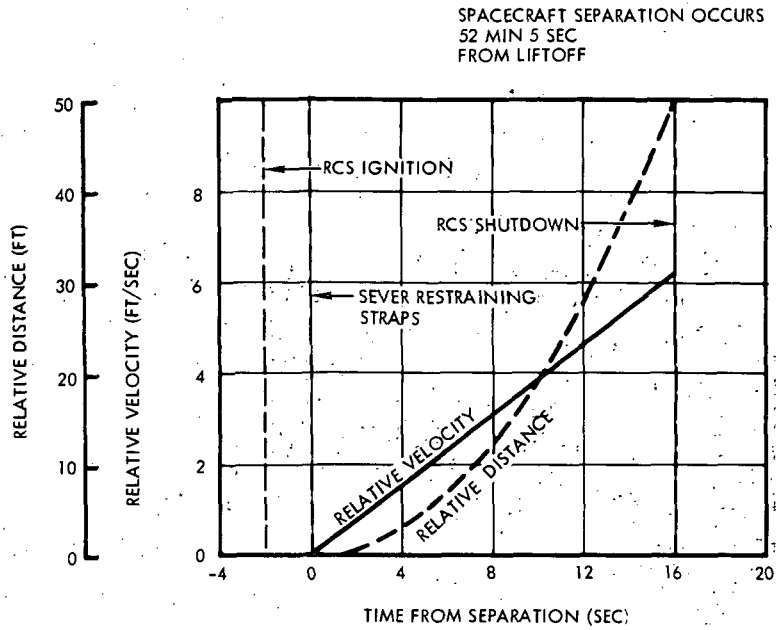

Figure 4-1. Spacecraft Separation; Relative Velocity and Distance During RCS Thrusting

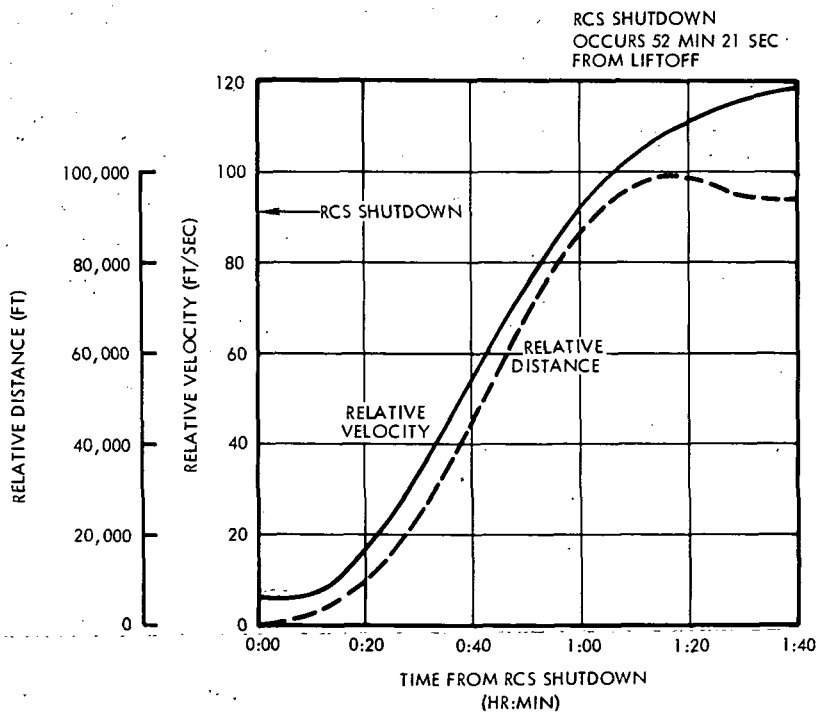

Figure 4-2. Spacecraft Separation; Relative Velocity and Distance History for Approximately 100 Minutes

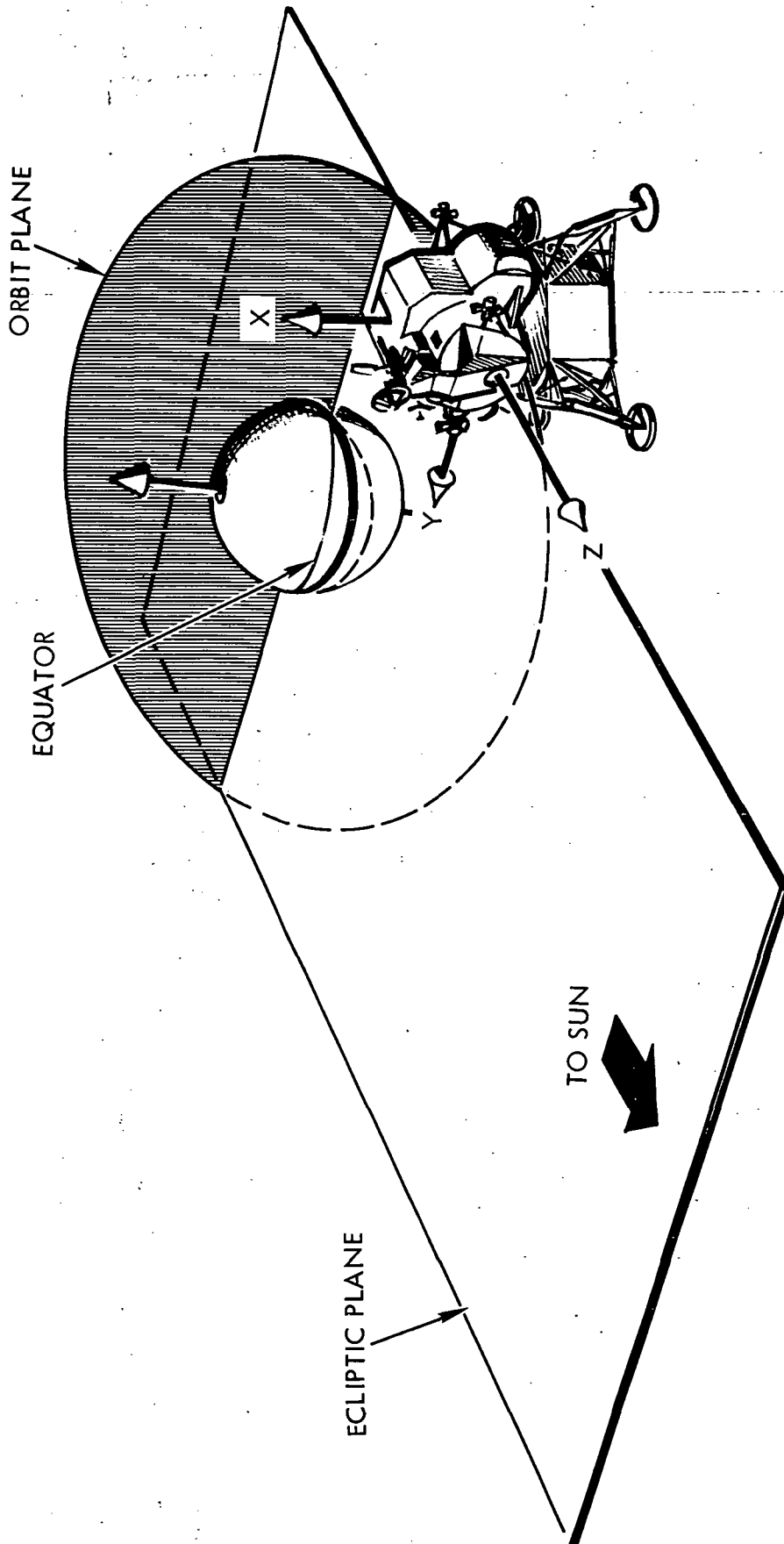

Figure 4-3. Spacecraft Cold-Soak Attitude Orientation

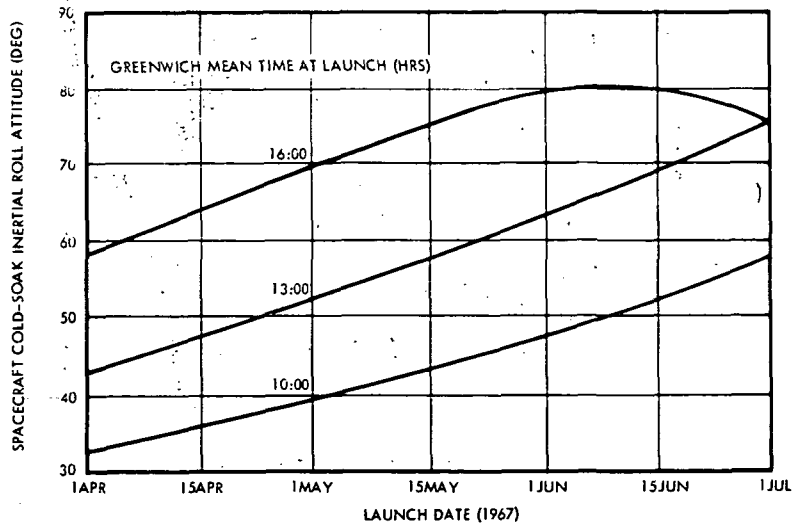
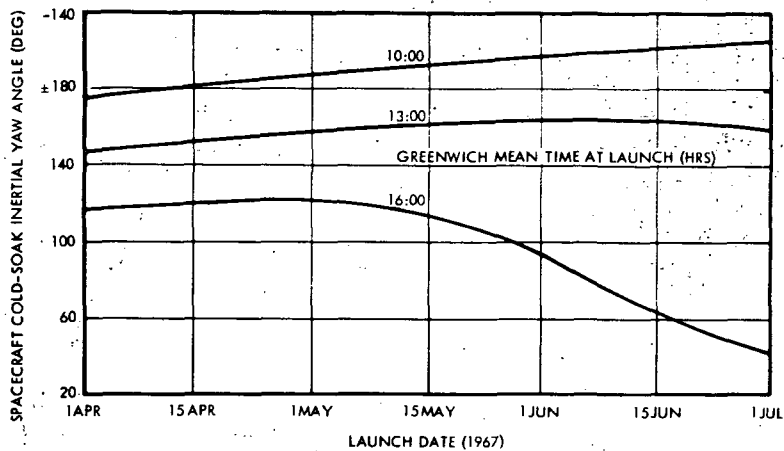
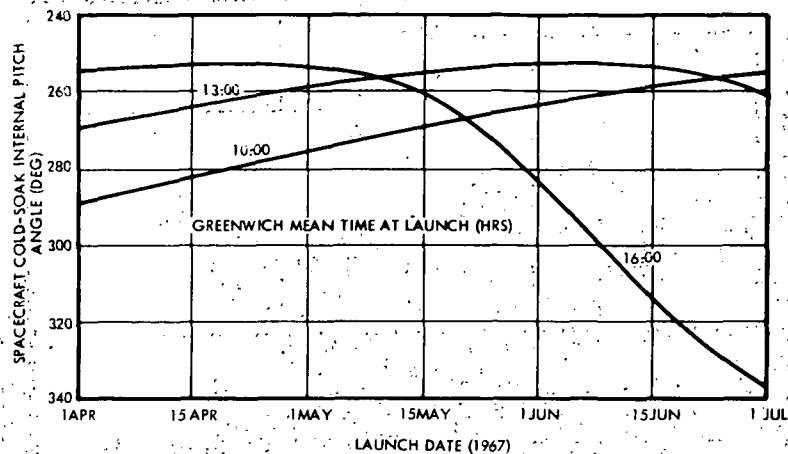

Figure 4-4. Cold-Soak Attitude Orientation History for Launches, Second Quarter, 1967



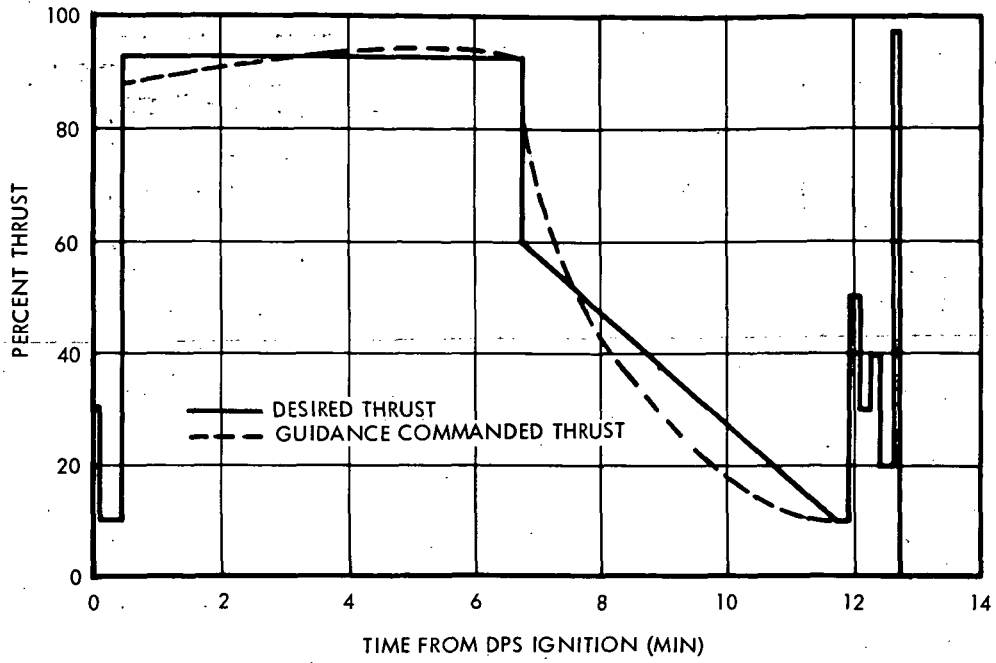

Figure 4-5. First DPS Burn Thrust Profile

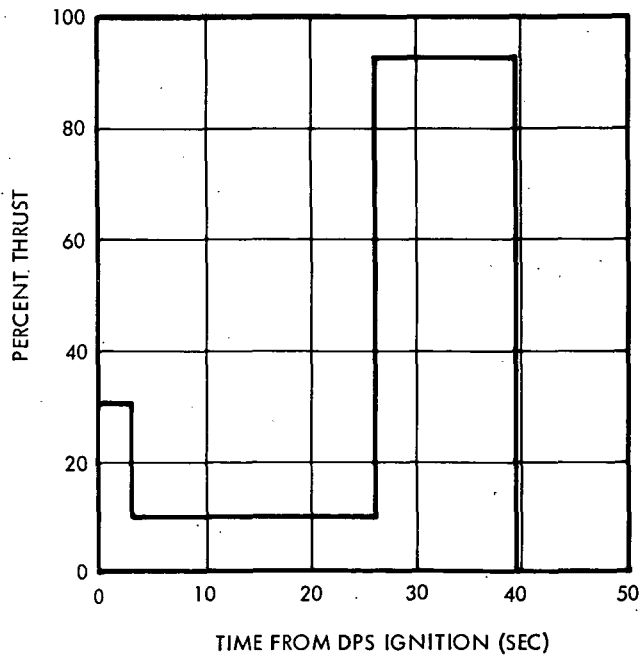

Figure 4-6. Second DPS Burn Thrust Profile

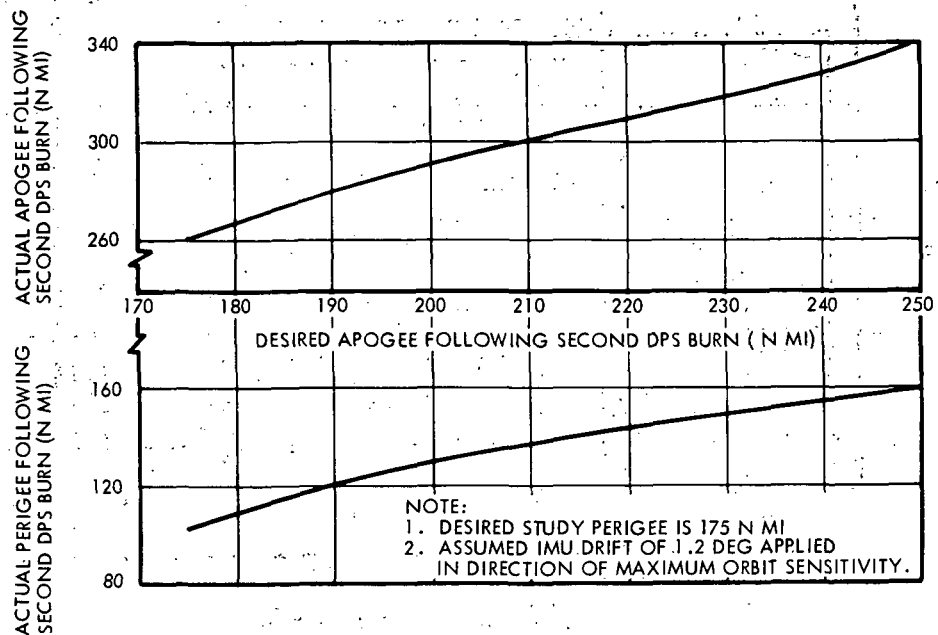

Figure 4-7. Effect of Assumed IMU Drift on Orbit Dimensions following Second DPS Burn

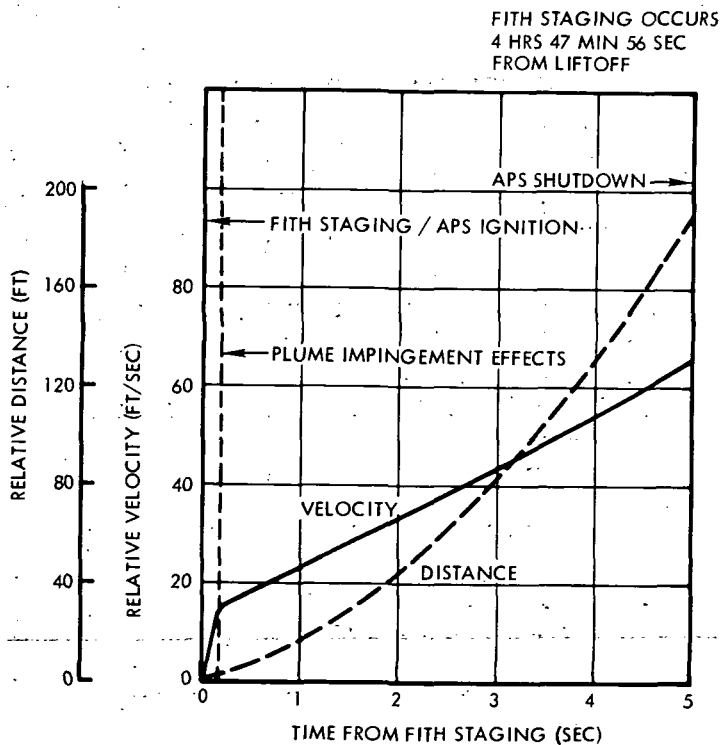

Figure 4-8. FITH Staging; Relative Velocity and Distance History During first APS Burn

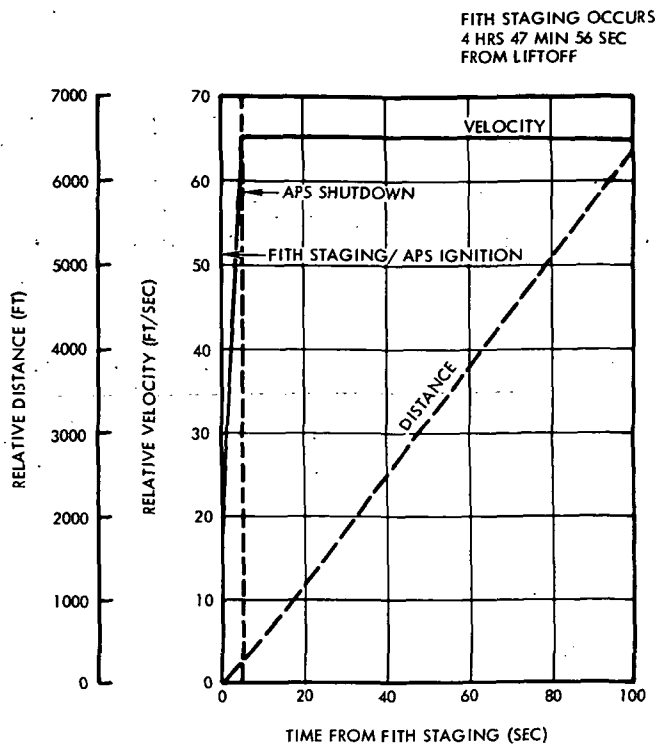

Figure 4-9. FITH Staging; Relative Velocity and Distance History to 100 Seconds

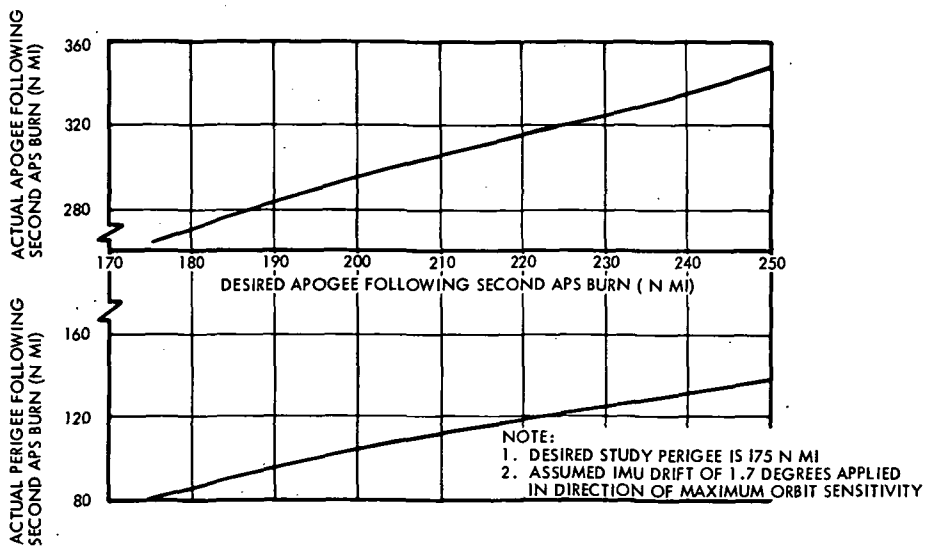

Figure 4-10. Effect of Assumed IMU Drift on Orbit Dimensions Following Second APS Burn

## 5. NOMINAL TRAJECTORY DATA

This section contains pertinent trajectory parameter histories of the nominal mission profile. These data, in tabular and graphical form, are based upon the trajectory data presented in Volume II of this report. Volume II also contains definitions of the trajectory parameters presented in this section.

### 5.1 MISSION PROFILE DATA

The time sequence of events for Apollo Mission AS-206A is presented in Table 5-1. Figures 5-1 through 5-4 present the earth ground track for the entire mission. Orbital characteristics of the spacecraft coast phases are presented in Table 5-2. Earth shadow data (daylight-darkness) are illustrated in Figures 5-1 through 5-4 and tabulated in Table 5-3.

### 5.2 TRAJECTORY PHASE DATA

Discrete events summaries and pertinent time history data of the spacecraft position, motion, and attitude are presented for the major mission phases as follows:

<u>Mission Phase</u>	<u>Table</u>	<u>Figures</u>
Ascent-to-Orbit	5-4	5-5 through 5-8
Spacecraft Separation	5-5	5-9 through 5-11
First DPS Burn	5-6	5-12 through 5-15
Second DPS Burn/FITH Staging/ First APS Burn	5-7	5-16 through 5-19
Second APS Burn	5-8	5-20 through 5-23
Third APS Burn	5-9	5-24 through 5-26
Fourth APS Burn	5-10	5-27 through 5-29

The spacecraft attitude angles presented in the figures are referenced to a launch-centered inertial coordinate system. This coordinate system and the spacecraft axis system are illustrated in Figures 3-7 and 3-8.

Table 5-1. Time Sequence of Events

<u>Event</u>	<u>Time From Liftoff (hr:min:sec)</u>
<b>Ascent-to-Orbit</b>	
Liftoff	00:00:00.0
S-IB Inboard Engines Shutdown	00:02:17.6
S-IB Outboard Engines Shutdown	00:02:23.6
S-IB Jettison/S-IVB Ignition	00:02:29.1
Jettison Boilerplate CSM	00:02:49.1
S-IVB Shutdown into Elliptical Earth Orbit	00:10:03.4
<b>S-IVB/Spacecraft Orbital Coast</b>	
S-IVB Shutdown into Elliptical Earth Orbit	00:10:03.4
SLA Petal Deployment	00:40:03.4
<b>Spacecraft Separation</b>	
RCS Ignition	00:52:02.8
Sever Restraining Straps	00:52:04.8
RCS Shutdown	00:52:20.8
<b>Spacecraft Orbital Cold-Soak</b>	
RCS Shutdown	00:52:20.8
Begin Cold-Soak Orientation Maneuver	00:52:30.8
End Cold-Soak Orientation Maneuver	00:53:26.1
<b>First DPS Burn</b>	
Maneuver to Pre-ignition Attitude	03:55:32.0
LEM Landing Gear Deployment	03:56:32.0
RCS Ignition	03:57:32.0
First DPS Ignition	03:57:38.0
First DPS Shutdown	03:58:16.7
<b>Second DPS Burn</b>	
Begin Pre-ignition Orientation Maneuver	04:33:13.2
RCS Ullage Maneuver	04:35:13.2
Second DPS Ignition	04:35:19.2
Second DPS Shutdown/FITH Staging/First APS Ignition	04:47:56.2
First APS Shutdown	04:48:01.5

Table 5-1. Time Sequence of Events (Continued)

<u>Event</u>	<u>Time From Liftoff (hr:min:sec)</u>
<b>Second APS Burn</b>	
Begin Pre-ignition Orientation Maneuver	06:09:04.9
RCS Ullage Maneuver	06:11:04.9
Second APS Ignition	06:11:07.4
Second APS Shutdown	06:17:42.1
<b>Third APS Burn</b>	
Begin Pre-ignition Orientation Maneuver	07:10:46.1
RCS Ullage Maneuver	07:12:46.1
Third APS Ignition	07:12:48.6
Third APS Shutdown	07:12:53.9
<b>Spacecraft Orbital Cold-Soak</b>	
Third APS Shutdown	07:12:53.9
Begin Cold-Soak Orientation Maneuver	07:13:03.9
End Cold-Soak Orientation Maneuver	07:13:57.6
<b>Fourth APS Burn</b>	
Begin Pre-ignition Attitude Maneuver	10:58:53.5
RCS Ullage Maneuver	11:00:53.5
Fourth APS Ignition	11:00:56.0
Fourth APS Shutdown	11:01:04.3
<b>Final Orbital Coast</b>	
Fourth APS Shutdown	11:01:04.3
End of Mission Profile	14:00:00.0

Table 5-2. Orbital Characteristics of the Spacecraft Coast Phases

Coast Following	Coast Duration (hr:min:sec)	Semi-Major Axis (ft)	Eccentricity (nd)	Inclination (deg)	Orbital Period (min)	Perigee (n mi)	Apogee (n mi)
Orbital Insertion*	00:41:59	21,548,233	0.004949	31.615	88.287	88.7	123.8
Spacecraft Separation	03:03:11	21,559,830	0.003328	31.617	88.359	96.3	119.9
First DPS Burn	00:34:56	21,812,966	0.008578	31.620	89.919	119.0	180.6
Second DPS Burn/FITH Abort Test/ First APS Burn	01:21:03	21,973,580	0.006563	30.464	90.914	152.5	200.0
Second APS Burn	00:53:10	22,015,840	0.005488	31.386	91.177	163.3	203.1
Third APS Burn	03:45:59	22,025,512	0.009757	31.399	91.237	149.4	220.1
Fourth APS Burn**	02:58:56	21,886,689	0.010306	31.396	90.376	124.8	199.0

\*S-IVB/SLA/LEM combination.

\*\*Mission profile terminates 14 hours after liftoff.

Table 5-3. Spacecraft Earth Shadow Data

Entrance Into Earth's Shadow (Time from Liftoff) (hr:min)	Exit From Earth's Shadow (Time from Liftoff) (hr:min)	Time In Earth's Shadow (min)
00:47	01:24	37
02:16	02:53	37
03:44	04:20	36
05:14	05:49	35
06:43	07:18	35
08:14	08:49	35
09:45	10:21	36
11:17	11:52	35
12:47	13:22	35



Table 5-4. Ascent-to-Orbit; Discrete Events Summary

<u>Event</u>	<u>Time From Liftoff</u> (hr:min:sec)	<u>Altitude*</u> (ft)	<u>Geodetic Latitude**</u> (deg)	<u>Longitude**</u> (deg)	<u>Inertial Velocity</u> (ft/sec)	<u>Inertial Flight Path Angle</u> (deg)	<u>Inertial Azimuth Angle</u> (deg)
Liftoff/Begin Vertical Rise	00:00:00.0	-9	28.532	-80.565	1,342	0.00	90.00
S-IB Inboard Engines Shutdown	00:02:17.6	170,420	28.688	-80.010	7,378	23.99	76.04
S-IB Outboard Engines Shutdown	00:02:23.6	188,576	28.716	-79.910	7,723	23.16	75.92
S-IVB Ignition	00:02:29.1	204,908	28.741	-79.816	7,671	22.09	75.98
Jettison Boilerplate CSM	00:02:49.1	259,661	28.837	-79.463	7,903	19.24	76.03
S-IVB Shutdown into Elliptical Earth Orbit	00:10:03.4	535,431	31.534	-62.031	25,685	-0.03	85.80

\*Altitude above the Fischer ellipsoid.

\*\*Minus coordinates indicate West longitudes and South latitudes.

Table 5-5. SLA Petal Deployment and Spacecraft Separation; Discrete Events Summary

Event	Time From Liftoff (hr:min:sec)	Altitude* (ft)	Geodetic Latitude** (deg)	Longitude** (deg)	Inertial Velocity (ft/sec)	Inertial Flight Path Angle (deg)	Inertial Azimuth Angle (deg)
SLA Petal Deployment	00:40:03.4	659,325	-13.499	51.107	25,528	0.22	118.93
RCS Ignition	00:52:02.8	720,238	-30.579	97.709	25,465	0.06	99.10
Sever Restraining Straps	00:52:04.8	720,312	-30.600	97.855	25,465	0.06	99.02
RCS Shutdown	00:52:20.8	720,894	-30.764	99.027	25,471	0.06	98.39

\*Altitude above the Fischer ellipsoid.

\*\*Minus coordinates indicate West longitudes and South latitudes.

Table 5-6. First DPS Burn; Discrete Events Summary

Event	Time From Liftoff (hr:min:sec)	Altitude* (ft)	Geodetic Latitude** (deg)	Longitude** (deg)	Inertial Velocity (ft/sec)	Inertial Flight Path Angle (deg)	Inertial Azimuth Angle (deg)
LEM Landing Gear Deployment	03:56:32.0	720,345	-30.050	89.028	25,471	-0.05	79.15
RCS Ullage Maneuver	03:57:32.0	717,824	-29.207	93.326	25,473	-0.07	76.91
First DPS Ignition	03:57:38.0	717,544	-29.114	93.752	25,476	-0.07	76.69
First DPS Shutdown	03:58:16.7	715,964	-28.478	96.484	25,622	0.00	75.31

\*Altitude above the Fischer ellipsoid.

\*\*Minus coordinates indicate West longitude and South latitudes.

Table 5-7. Second DPS Burn/FITH Abort Test/First APS Burn; Discrete Events Summary

Event	Time From Liftoff (hr:min:sec)	Altitude* (ft)	Geodetic Latitude** (deg)	Longitude** (deg)	Inertial Velocity (ft/sec)	Inertial Flight Path Angle (deg)	Inertial Azimuth Angle (deg)
RCS Ullage Maneuver	4:35:13.2	1,036,878	31.588	-128,971	25,250	0.24	86.28
Second DPS Ignition	4:35:19.2	1,037,540	31.613	-128,534	25,249	0.24	86.52
FITH Staging/First APS Ignition	4:47:56.2	1,204,564	28.469	-73.614	25,152	0.08	101.88
First APS Shutdown	4:48:01.5	1,204,677	28.398	-73.256	25,148	0.08	101.93

\*Altitude above the Fischer ellipsoid.

\*\*Minus coordinates indicate West longitudes and South latitudes.

Table 5-8. Second APS Burn; Discrete Events Summary

Event	Time From Liftoff (hr:min:sec)	Altitude* (ft)	Geodetic Latitude** (deg)	Longitude** (deg)	Inertial Velocity (ft/sec)	Inertial Flight Path Angle (deg)	Inertial Azimuth Angle (deg)
RCS Ullage Maneuver	06:11:04.9	1,169,998	30.224	-128.800	25,189	0.27	84.82
Second APS Ignition	06:11:07.4	1,170,309	30.239	-128.622	25,189	0.27	84.90
Second APS Shutdown	06:17:42.1	1,228,519	31.524	-100.343	25,149	-0.05	88.48

\*Altitude above the Fischer ellipsoid.

\*\*Minus coordinates indicate West longitudes and South latitudes.

Table 5-9. Third APS Burn; Discrete Events Summary

Event	Time From Liftoff (hr:min:sec)	Altitude* (ft)	Geodetic Latitude** (deg)	Longitude** (deg)	Inertial Velocity (ft/sec)	Inertial Flight Path Angle (deg)	Inertial Azimuth Angle (deg)
RCS Ullage Maneuver	07:12:46.1	999,465	-25.065	108.898	25,408	0.25	70.25
Third APS Ignition	07:12:48.6	999,701	-25.009	109.060	25,408	0.27	70.18
Third APS Shutdown	07:12:53.9	1,000,457	-24.890	109.398	25,409	0.48	70.03

\*Altitude above the Fischer ellipsoid.

\*\*Minus coordinates indicate West longitudes and South latitudes.

Table 5-10. Fourth APS Burn; Discrete Events Summary

Event	Time From Liftoff (hr:min:sec)	Altitude* (ft)	Geodetic Latitude** (deg)	Longitude** (deg)	Inertial Velocity (ft/sec)	Inertial Flight Path Angle (deg)	Inertial Azimuth Angle (deg)
RCS Ullage Maneuver	11:00:53.5	1,119,697	24.849	-128.758	25,189	-0.46	110.03
Fourth APS Ignition	11:00:56.0	1,191,145	24.793	-128.600	25,187	-0.45	110.10
Fourth APS Shutdown	11:01:04.3	1,189,868	24.606	-128.080	25,110	-0.16	110.32

\*Altitude above the Fischer ellipsoid.

\*\*Minus coordinates indicate West longitudes and South latitudes.

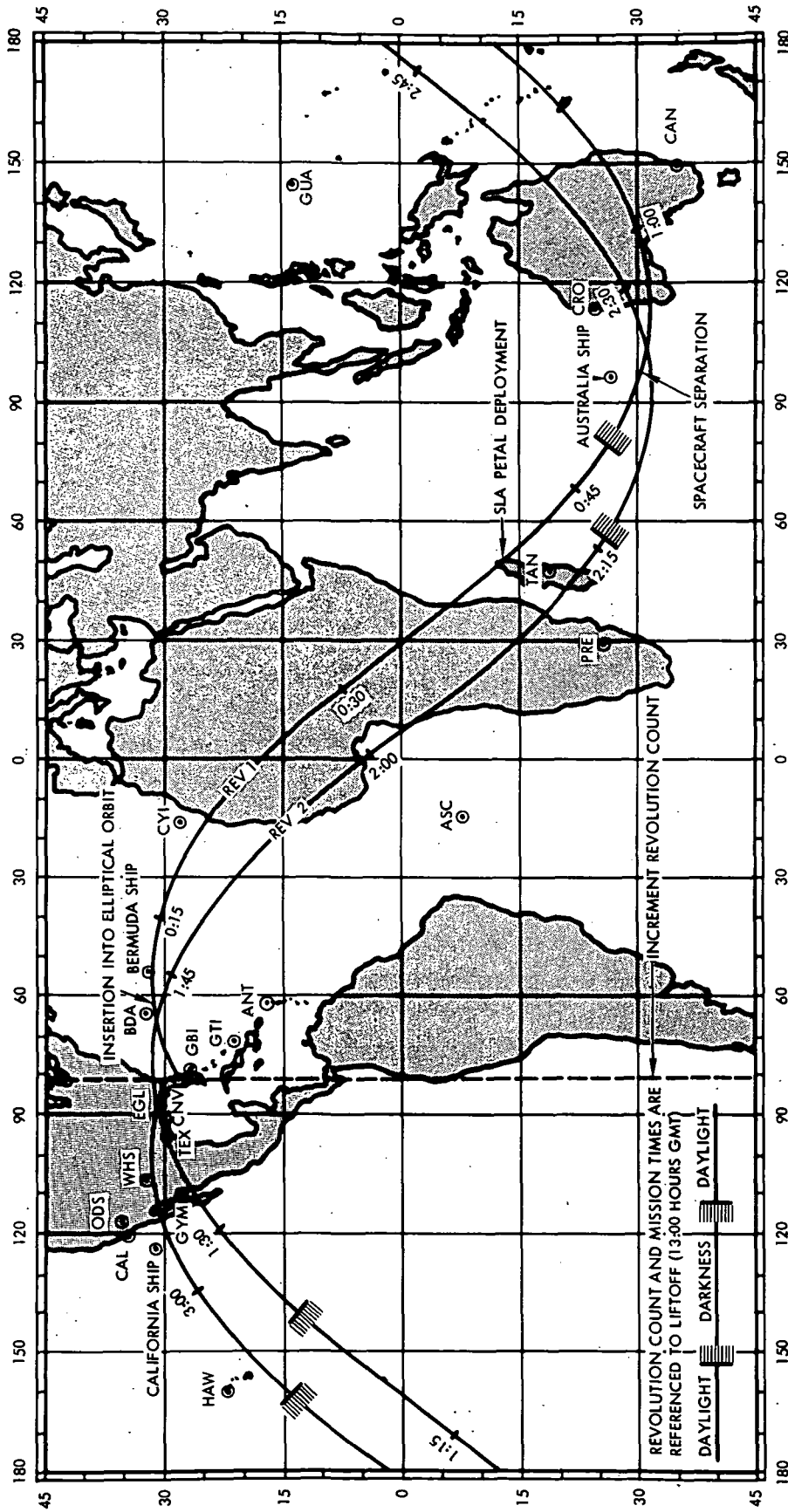

Figure 5-1. Earth Ground Track; Revolutions One and Two

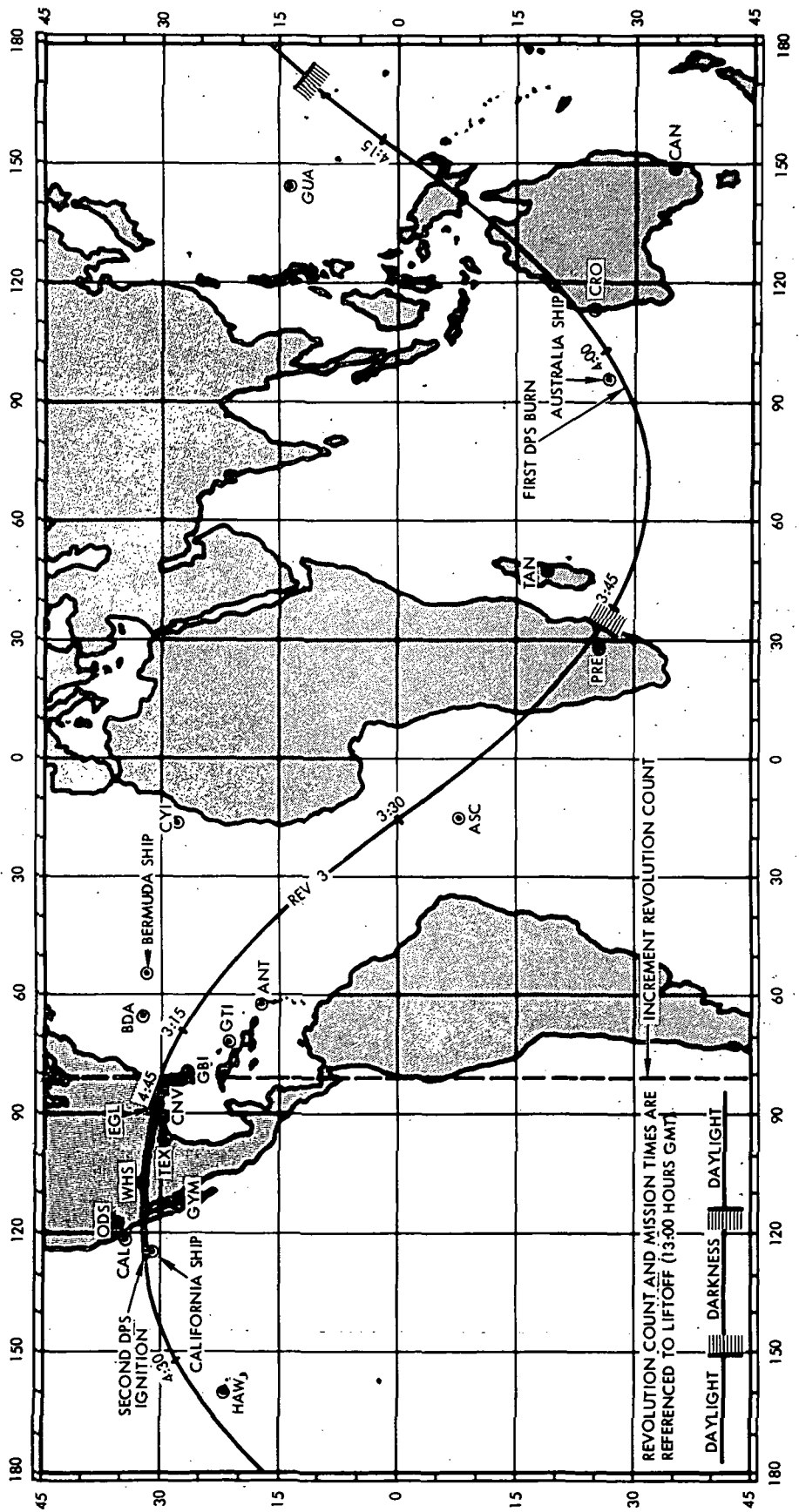

Figure 5-2. Earth Ground Track; Revolution Three

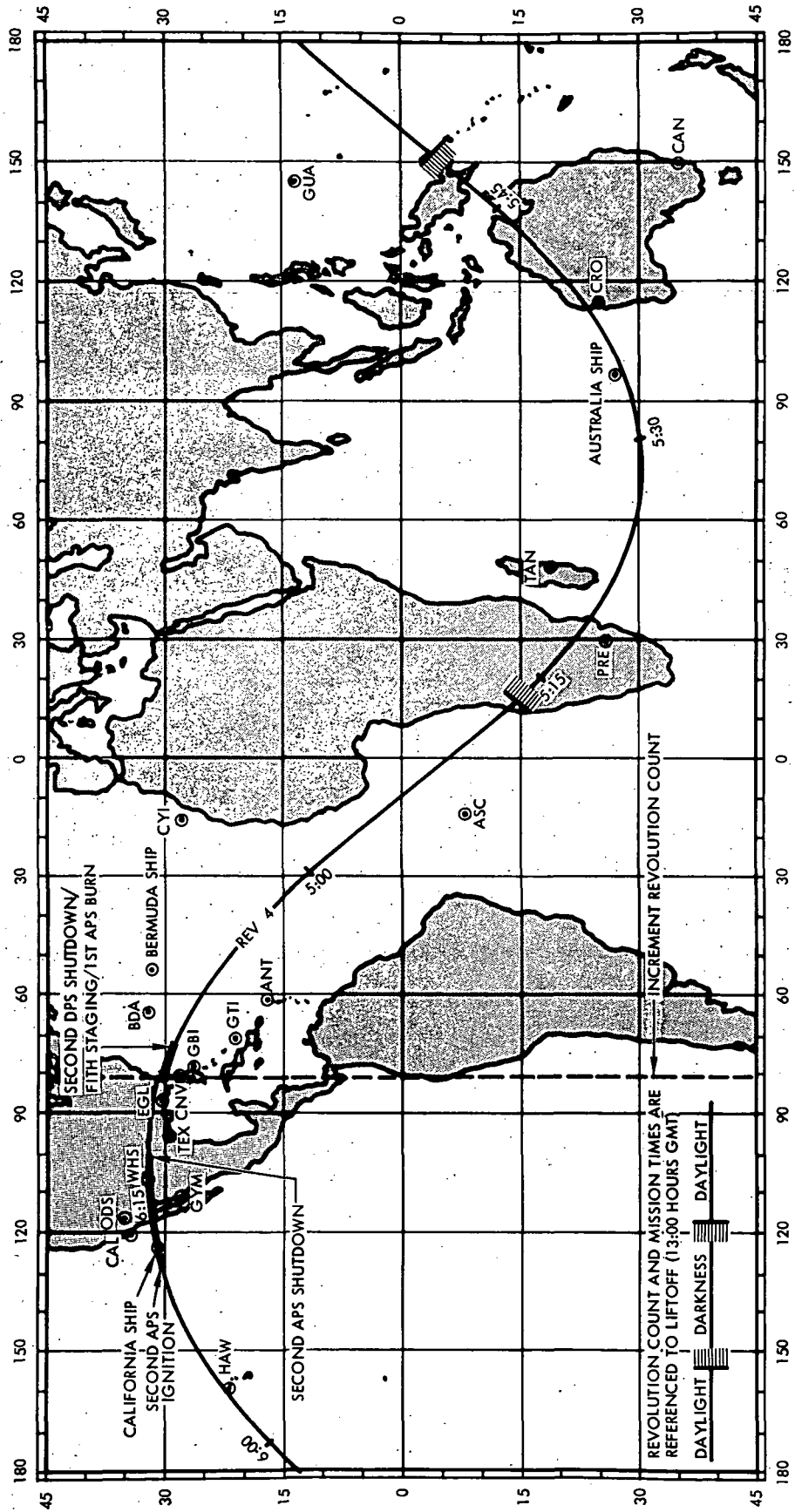

Figure 5-3. Earth Ground Track; Revolution Four

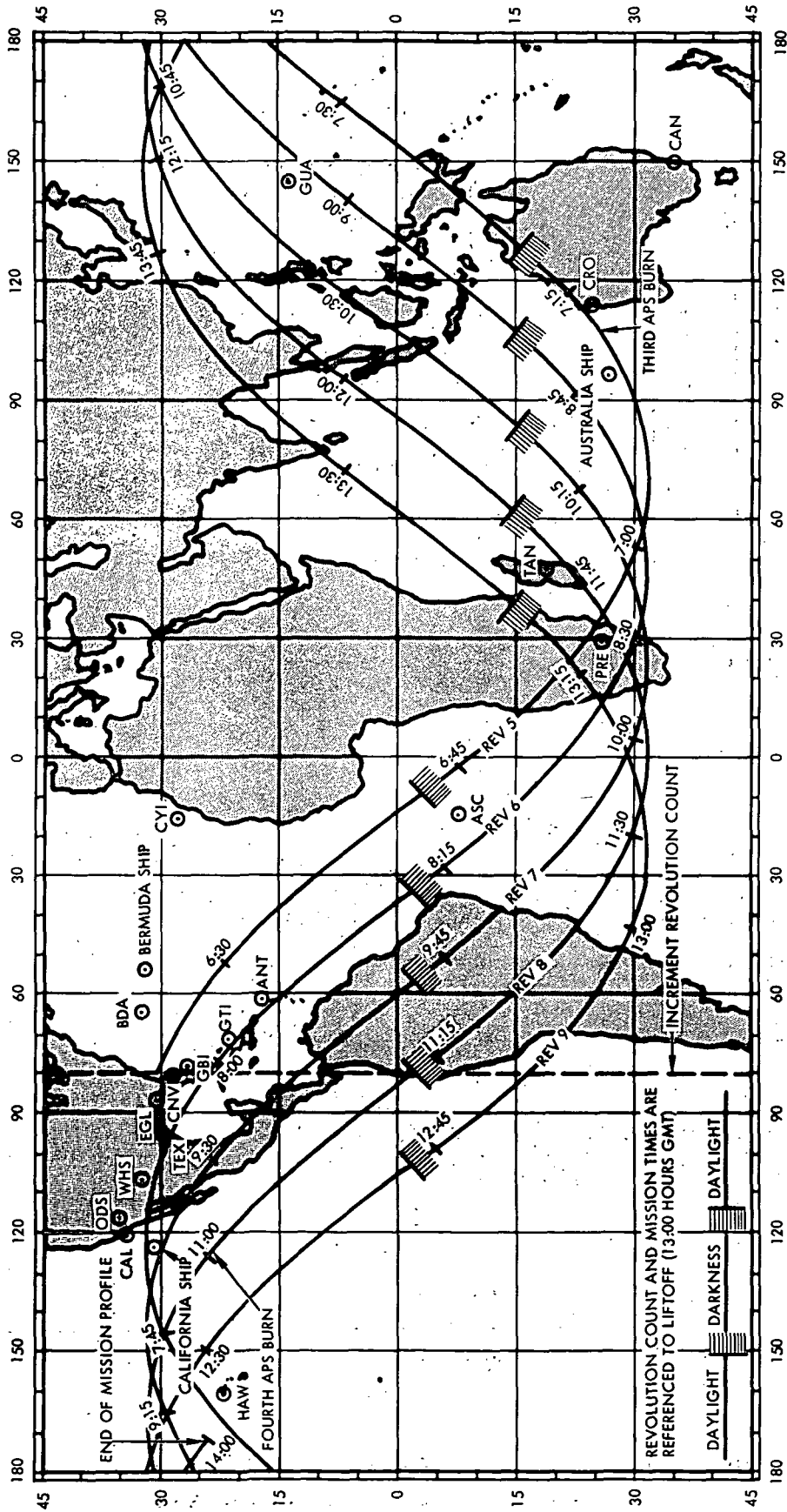

Figure 5-4. Earth Ground Track; Revolutions Five Through Nine



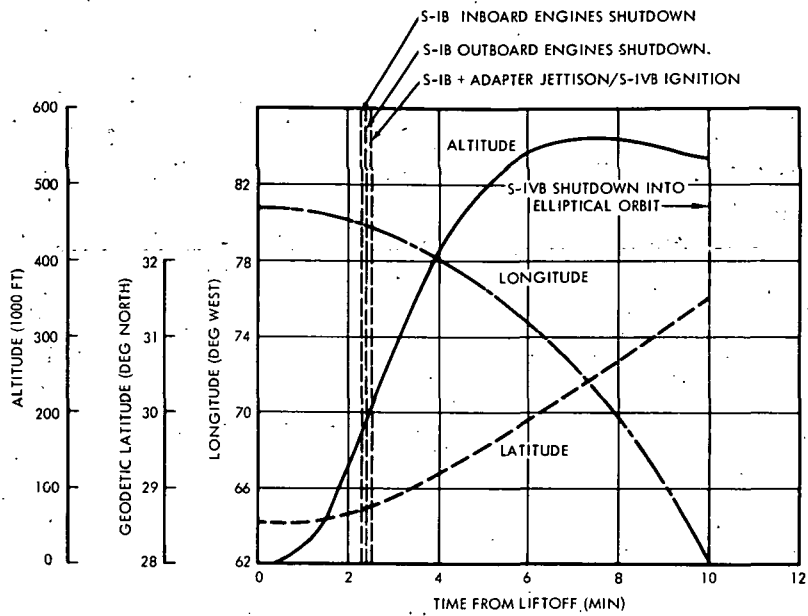

Figure 5-5. Ascent-to-Orbit; Altitude, Geodetic Latitude, and Longitude

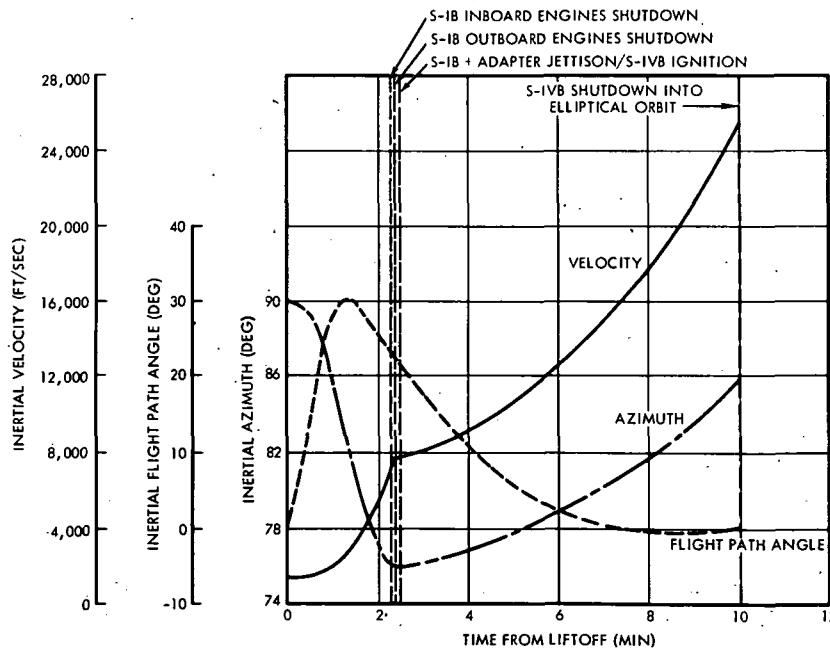

Figure 5-6. Ascent-to-Orbit; Inertial Velocity, Inertial Flight Path Angle, and Inertial Azimuth

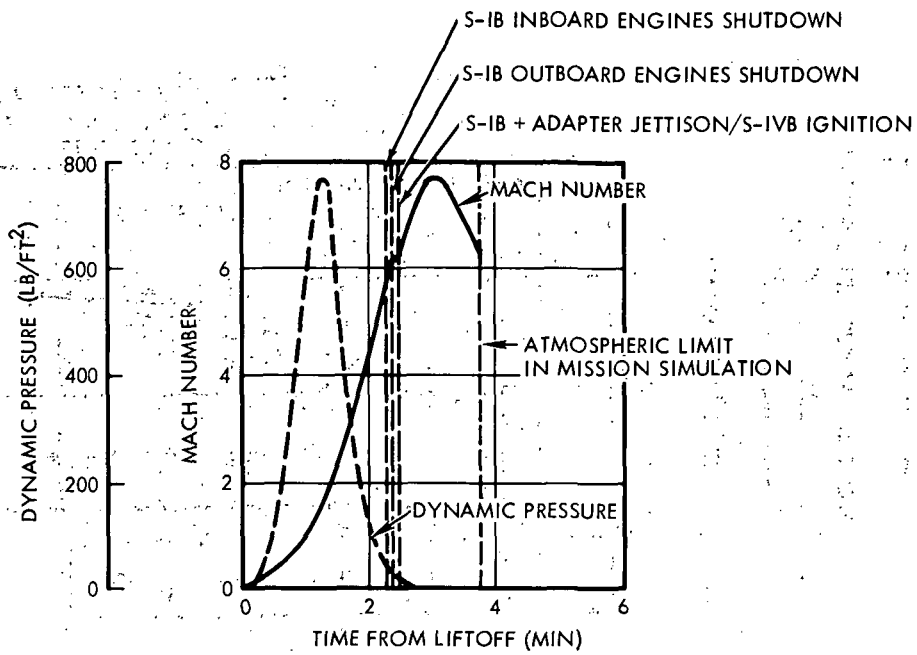

Figure 5-7. Ascent-to-Orbit; Dynamic Pressure and Mach Number

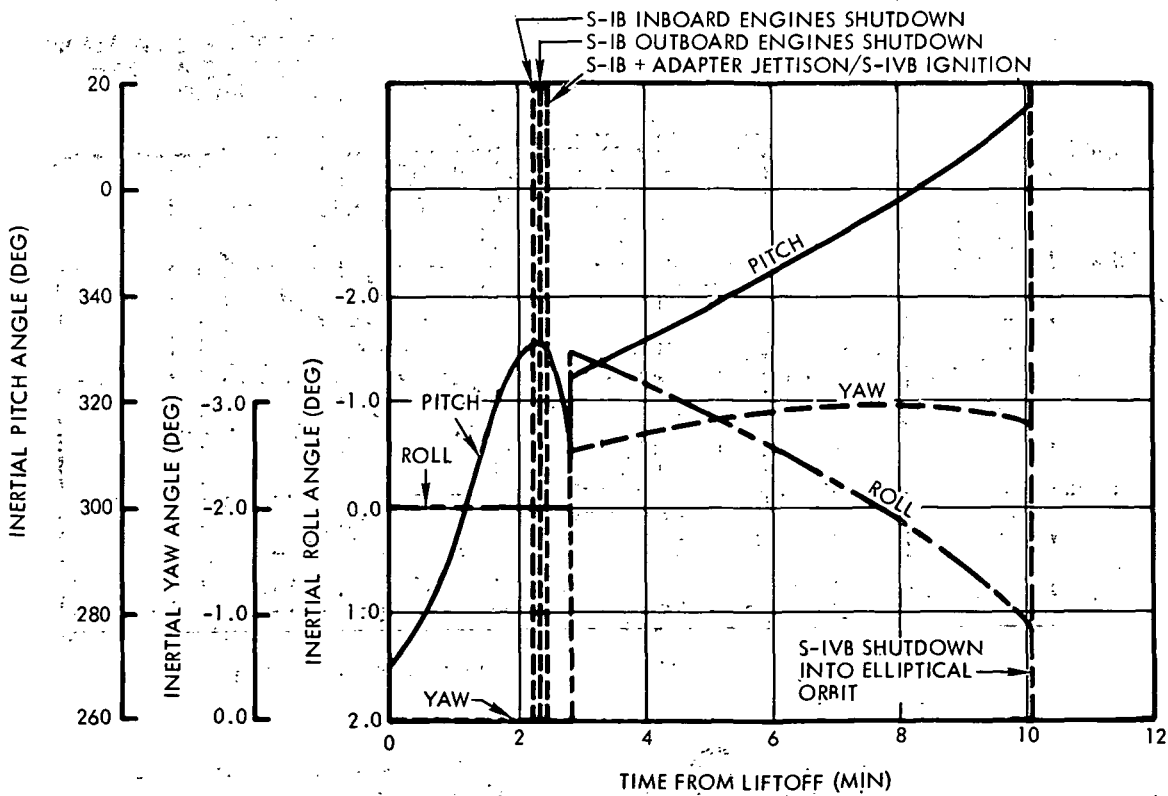

Figure 5-8. Ascent-to-Orbit; Launch Site Inertial Attitude History

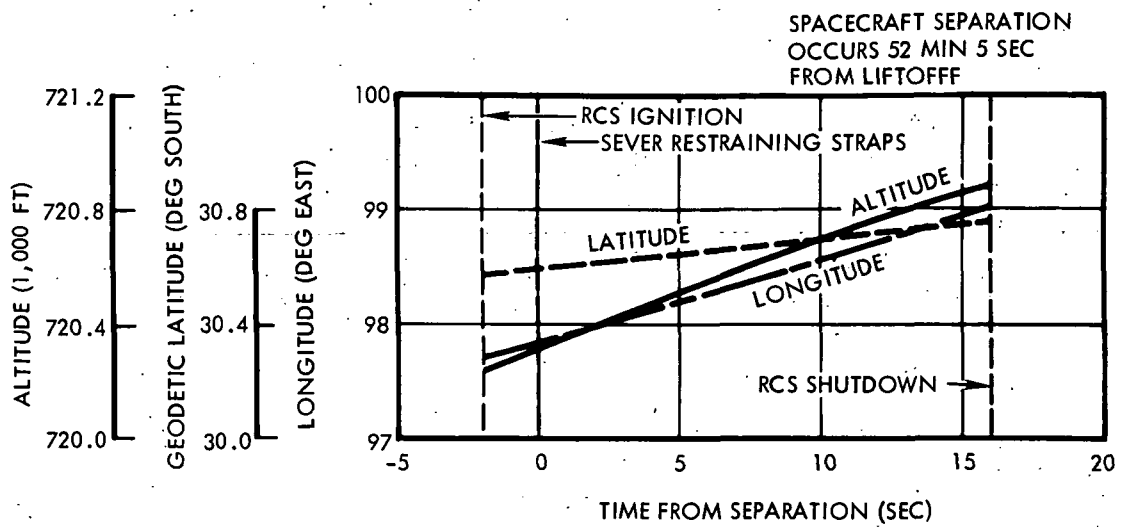

Figure 5-9. Spacecraft Separation; Altitude, Geodetic Latitude, and Longitude

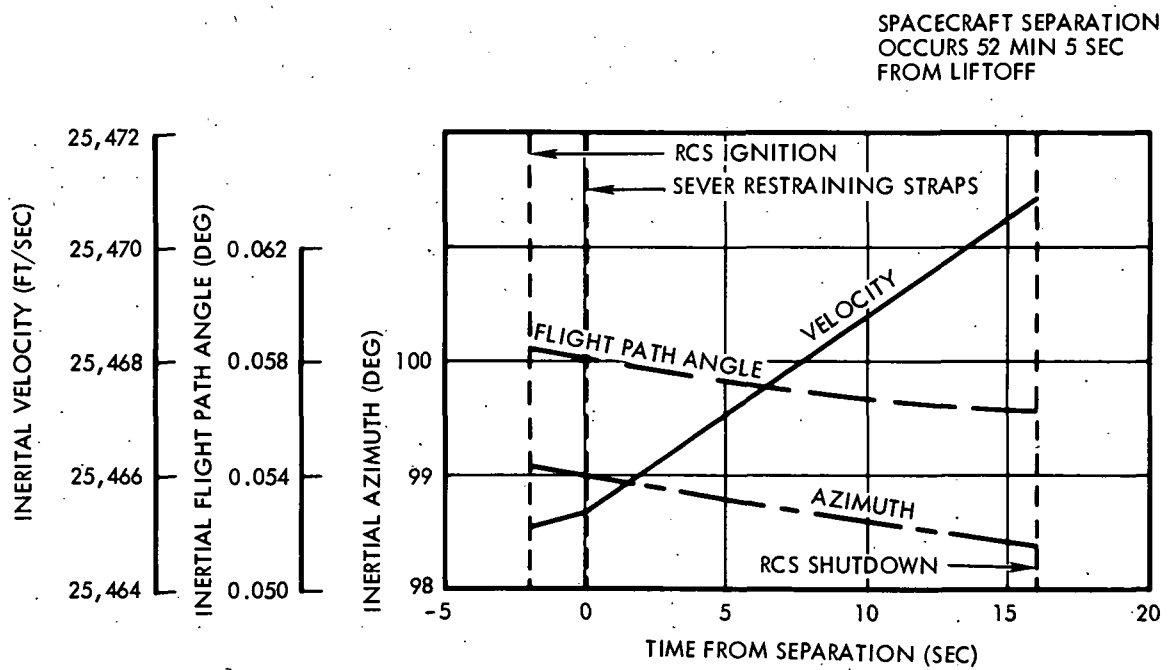

Figure 5-10. Spacecraft Separation; Inertial Velocity, Inertial Flight Path Angle, and Inertial Azimuth

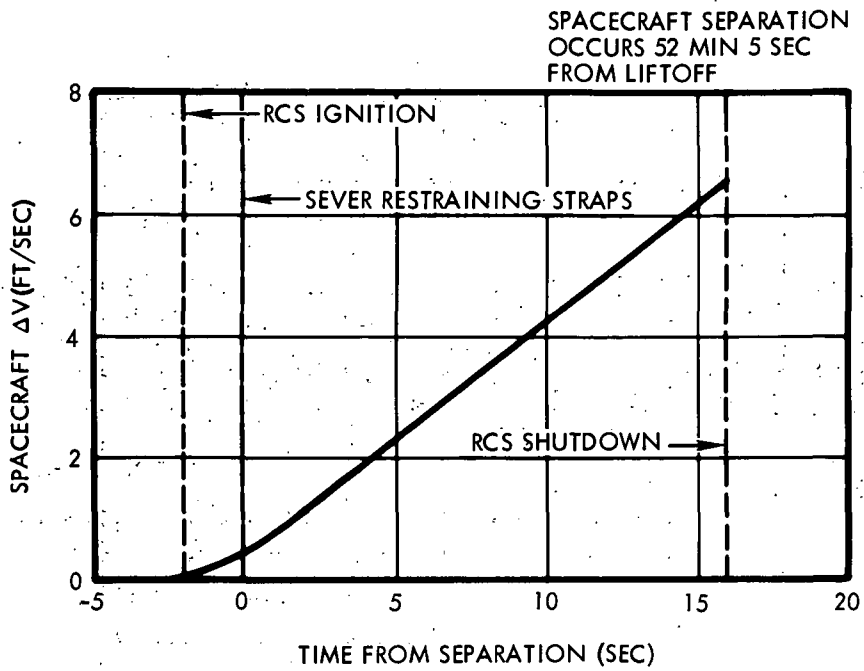

Figure 5-11. Spacecraft Separation;  $\Delta V$  History

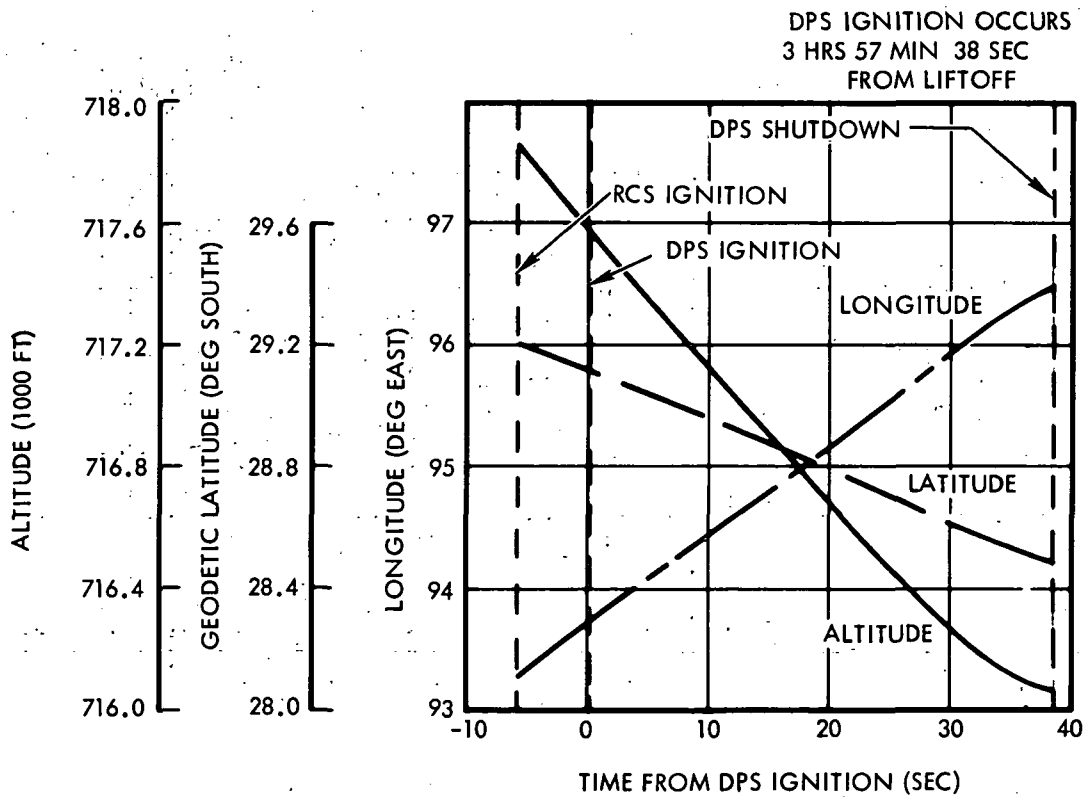

Figure 5-12. First DPS Burn; Altitude, Geodetic Latitude, and Longitude

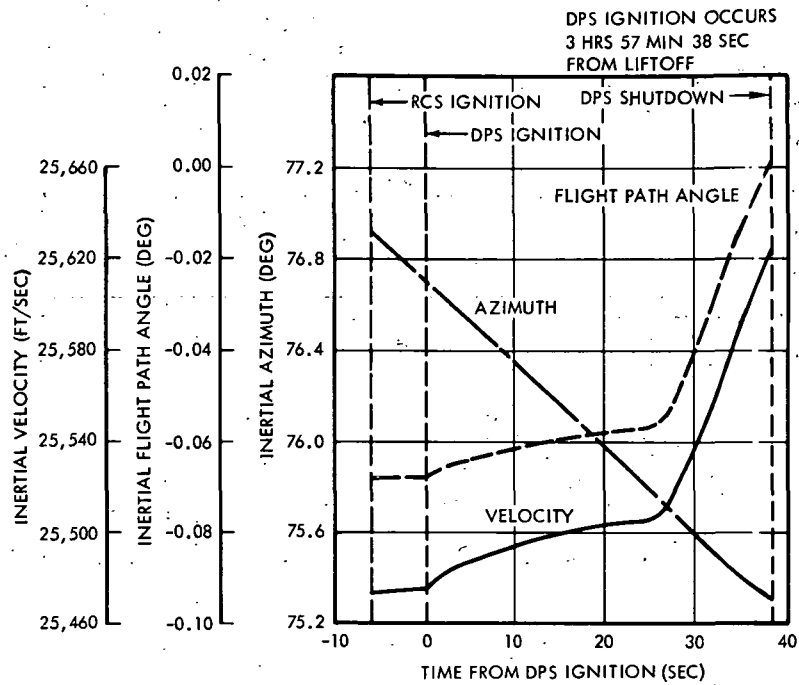

Figure 5-13. First DPS Burn; Inertial Velocity, Inertial Flight Path Angle, and Inertial Azimuth

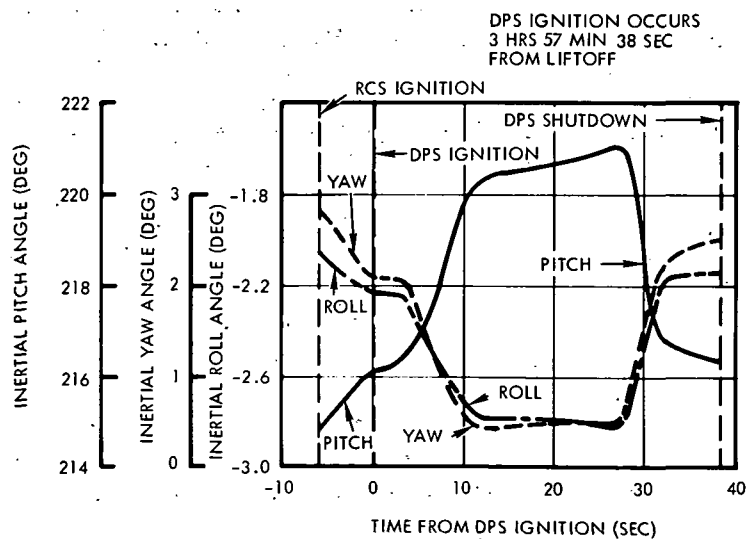

Figure 5-14. First DPS Burn; Launch Site Inertial Attitude History

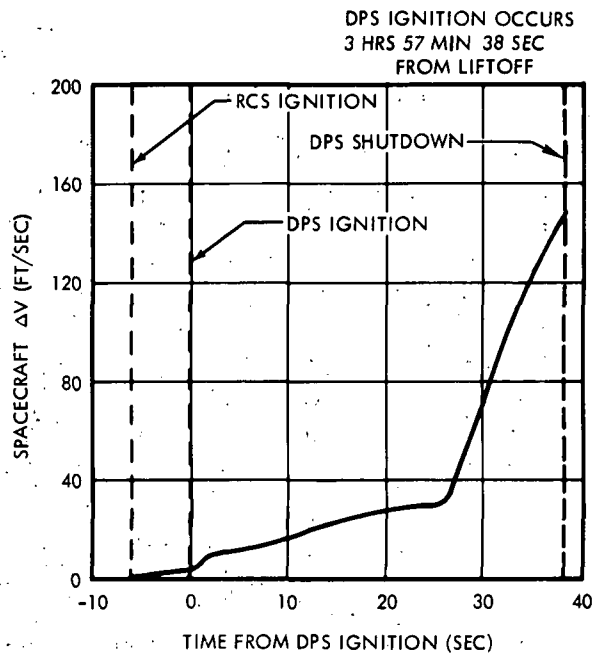

Figure 5-15. First DPS Burn;  $\Delta V$  History

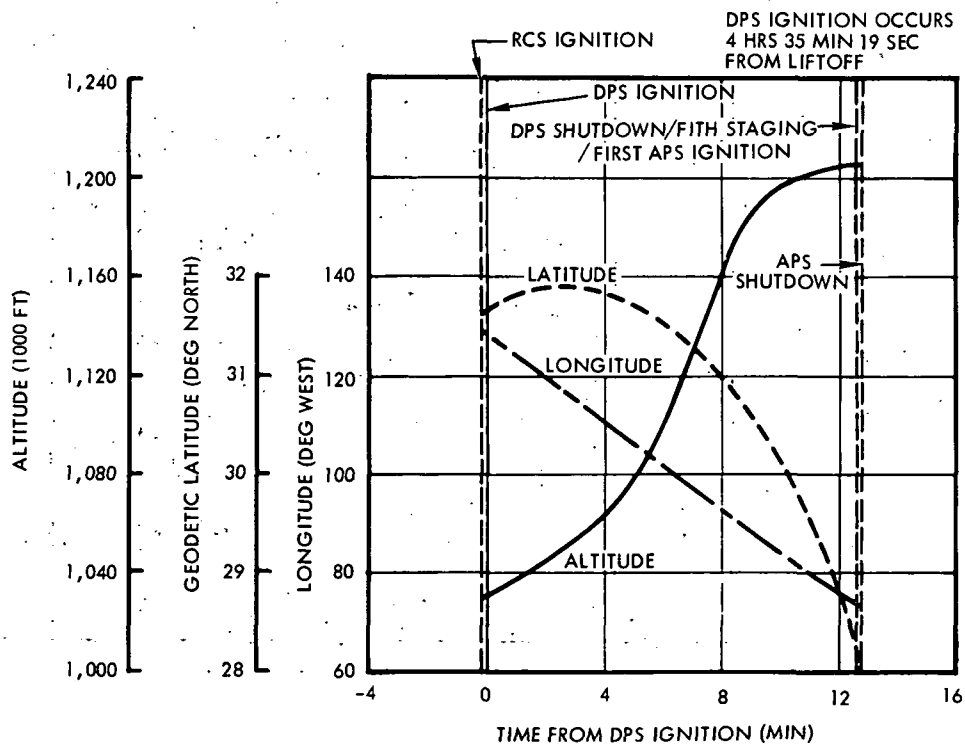

Figure 5-16. Second DPS Burn/FITH Staging/First APS Burn; Altitude, Geodetic Latitude, and Longitude

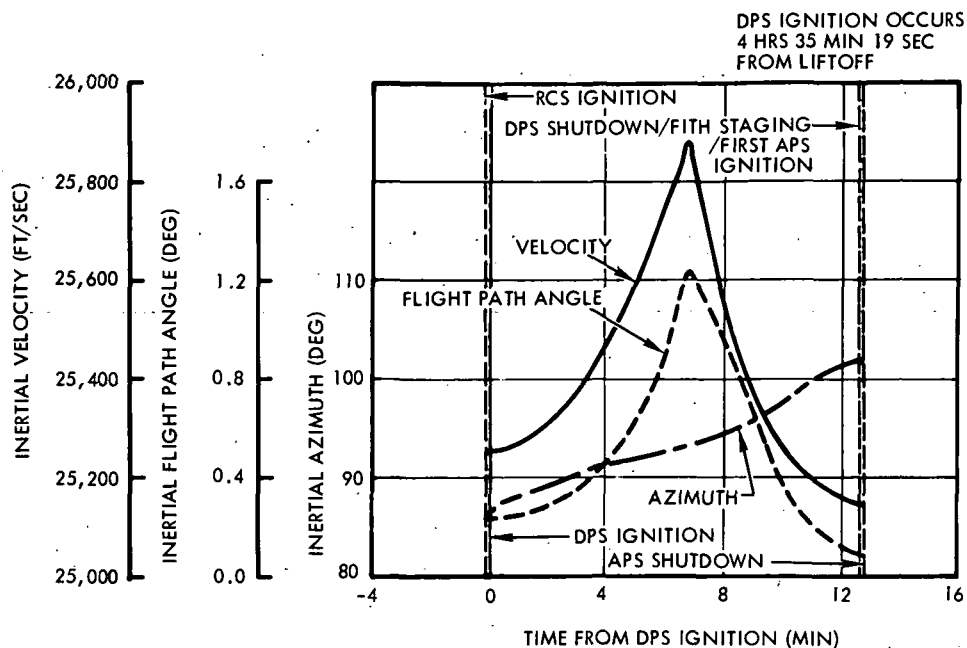

Figure 5-17. Second DPS Burn/FITH Staging/First APS Burn; Inertial Velocity, Inertial Flight Path Angle, and Inertial Azimuth

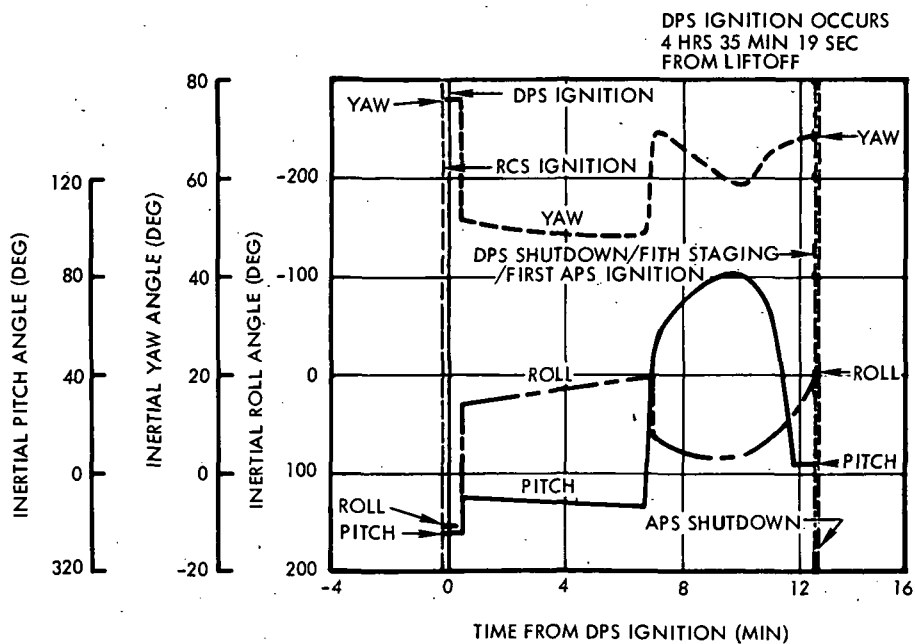

Figure 5-18. Second DPS Burn/FITH Staging/First APS Burn; Launch Site Inertial Attitude History

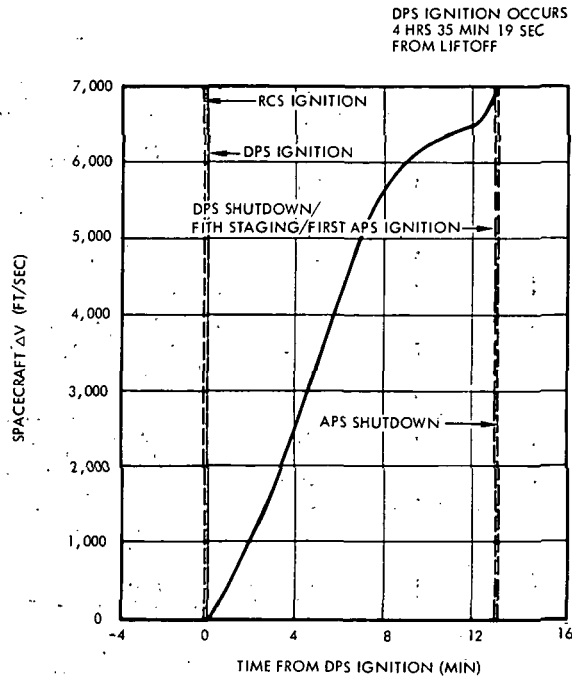

Figure 5-19. Second DPS Burn/FITH Staging/First APS Burn;  
 $\Delta V$  History

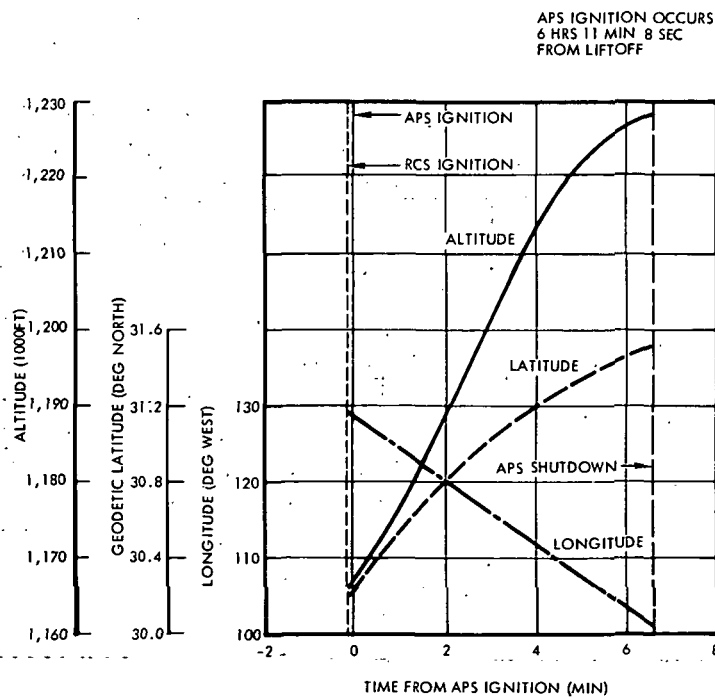

Figure 5-20. Second APS Burn; Altitude, Geodetic Latitude,  
and Longitude



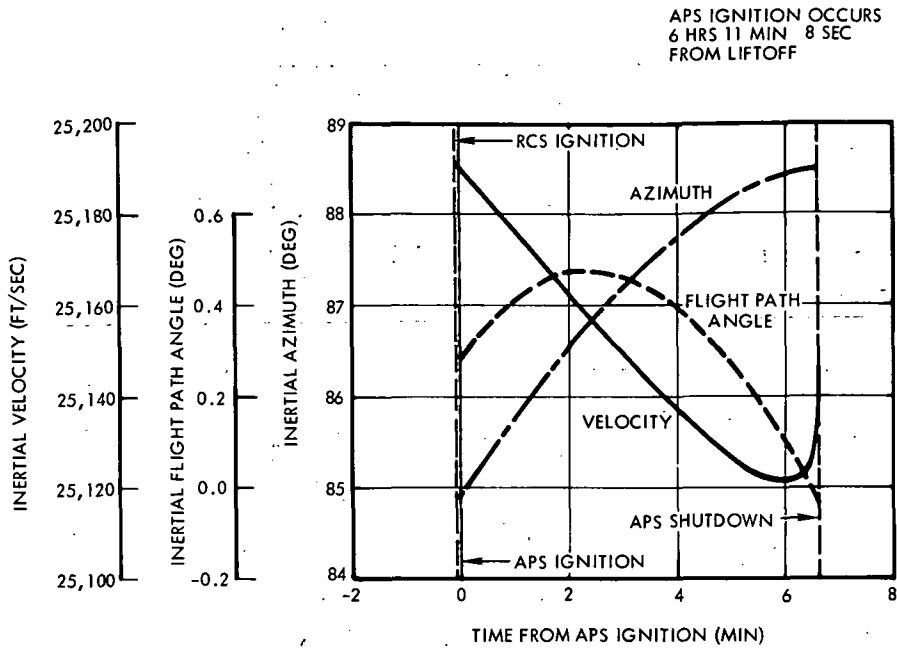

Figure 5-21. Second APS Burn; Inertial Velocity, Inertial Flight Path Angle, and Inertial Azimuth

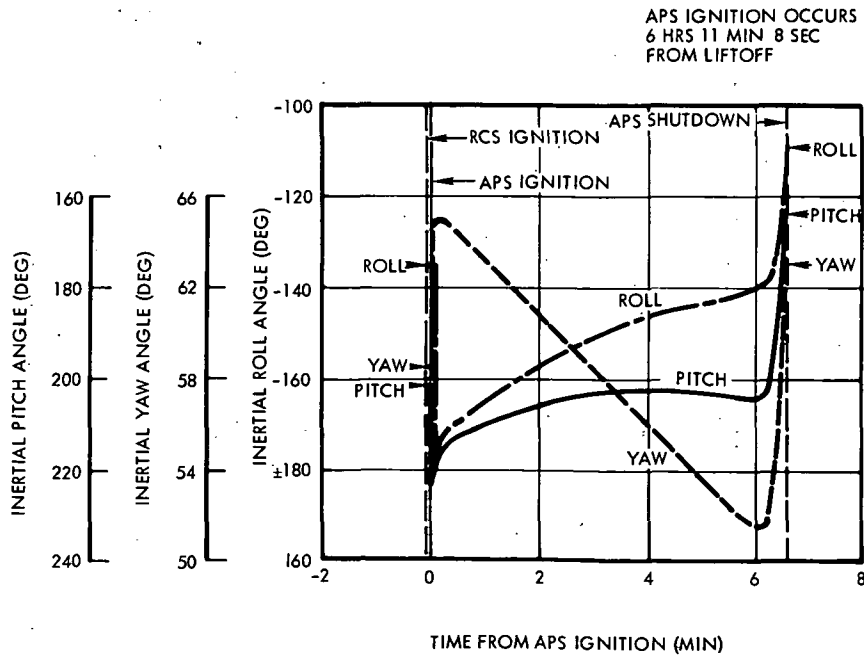

Figure 5-22. Second APS Burn; Launch Site Inertial Attitude History

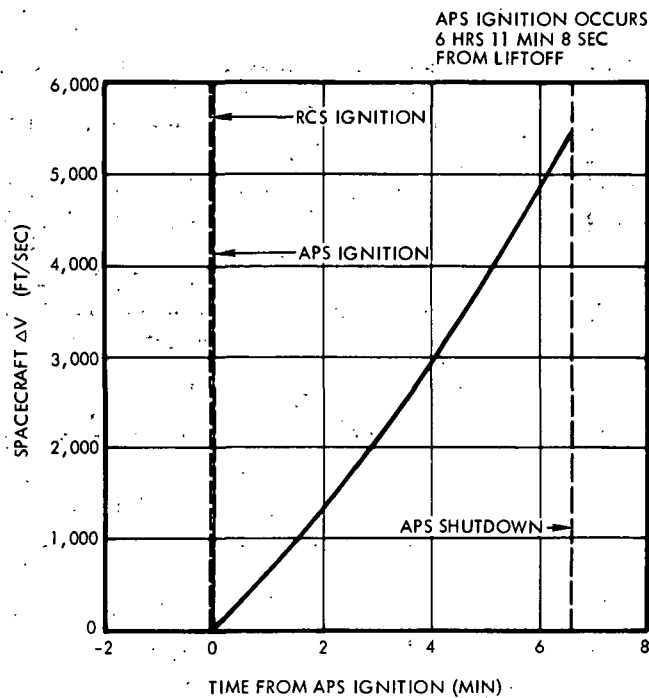

Figure 5-23. Second APS Burn;  $\Delta V$  History

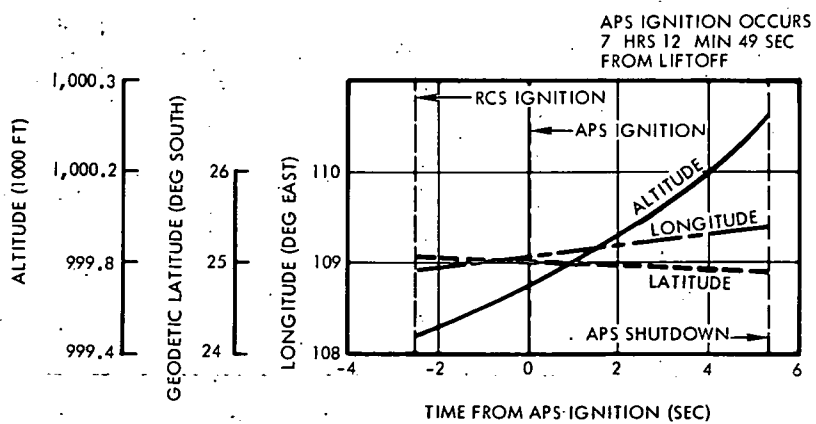

Figure 5-24. Third APS Burn; Altitude, Geodetic Latitude, and Longitude

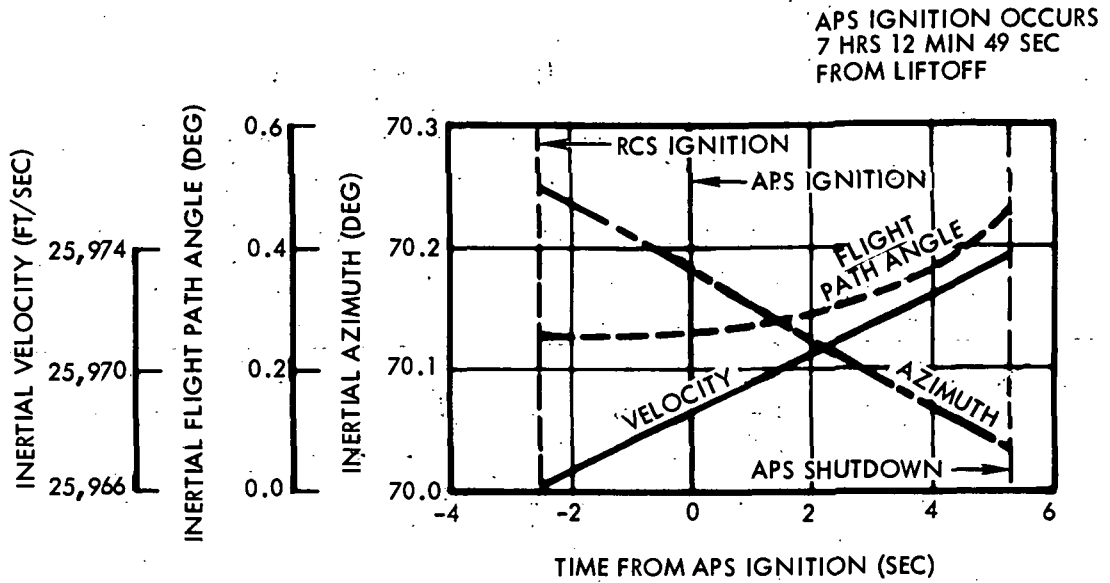

Figure 5-25. Third APS Burn; Inertial Velocity, Inertial Flight Path Angle, and Inertial Azimuth

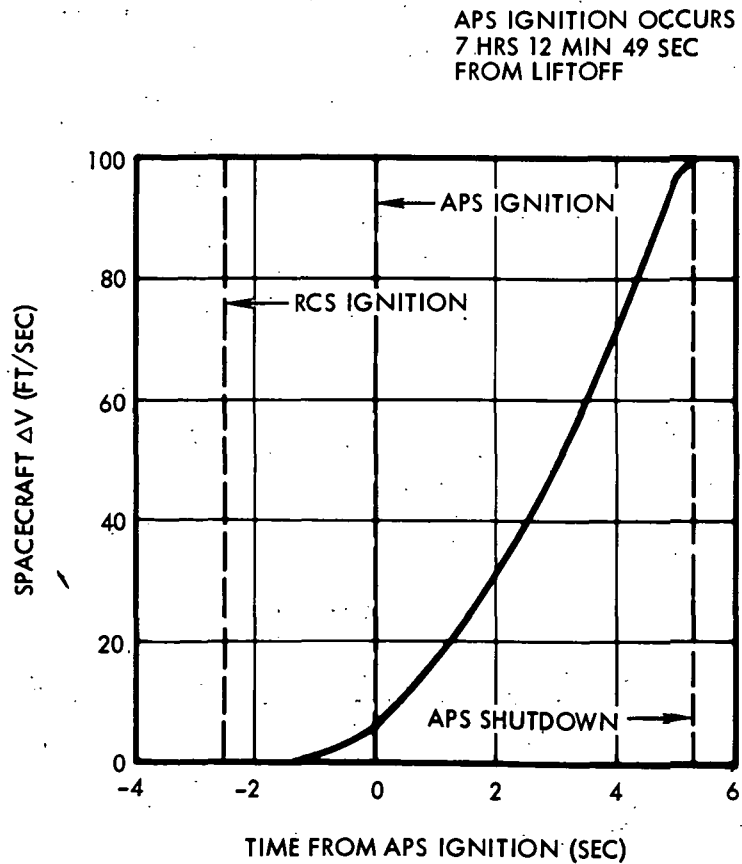

Figure 5-26. Third APS Burn;  $\Delta V$  History

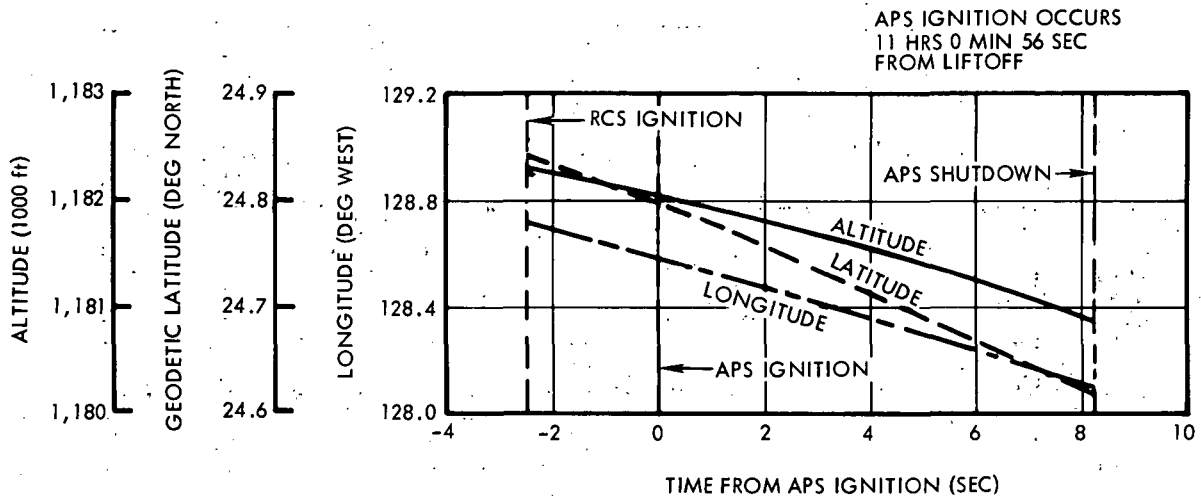

Figure 5-27. Fourth APS Burn; Altitude, Geodetic Latitude, and Longitude

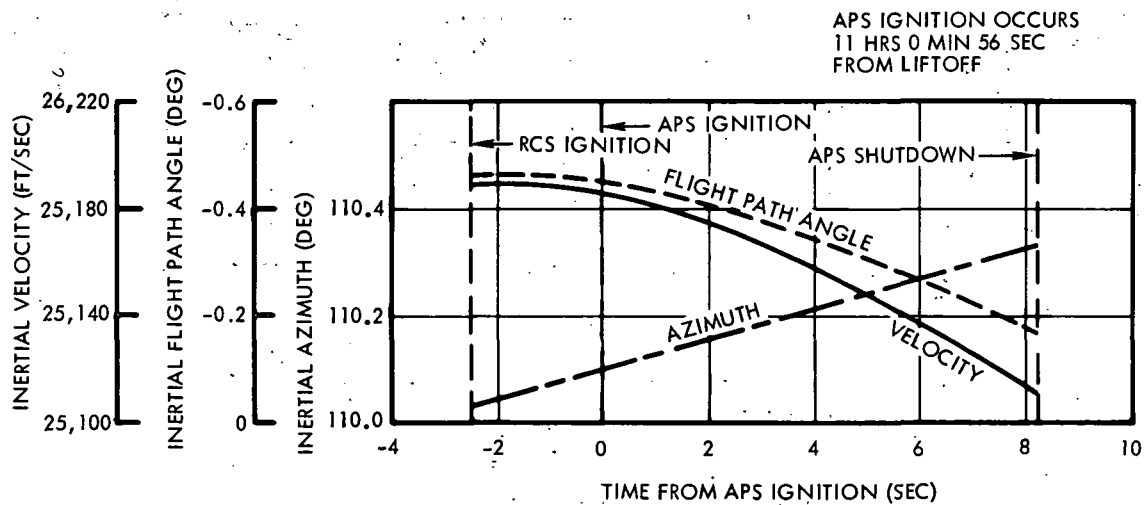

Figure 5-28. Fourth APS Burn; Inertial Velocity, Inertial Flight Path Angle, and Inertial Azimuth

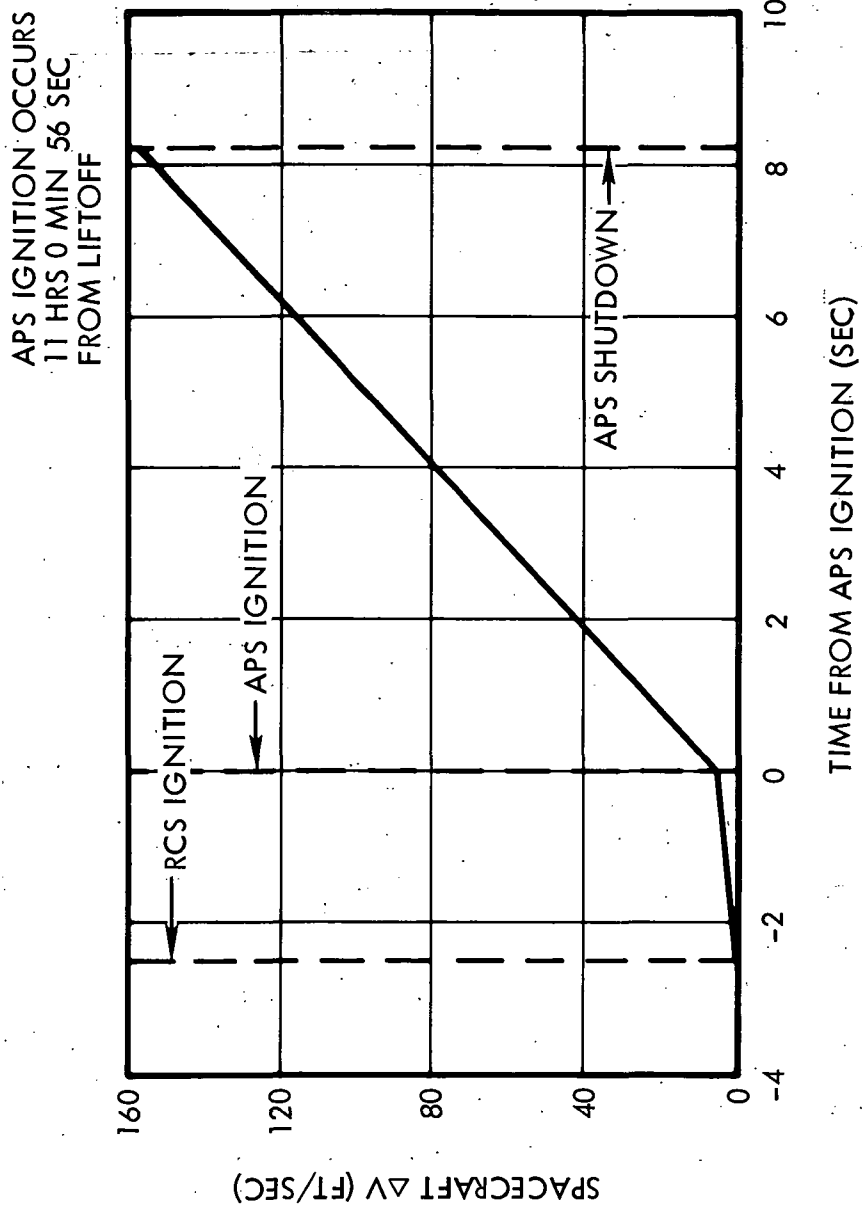

Figure 5-29. Fourth APS Burn;  $\Delta V$  History

## 6. MSFN COVERAGE DATA

Spacecraft visibility periods for the MSFN stations presented in Table 3-1 are listed in Table 6-1. Also presented in this table are the approximate minimum and maximum slant ranges between the spacecraft and the MSFN station during each visibility period. Table 6-2 presents the time intervals in which the spacecraft is not visible from a MSFN station. The spacecraft is considered visible when the line-of-sight between the spacecraft and the MSFN station is 85 degrees or less with respect to the station vertical and the slant range distance is less than 740 nautical miles. The MSFN coverage during major mission events is illustrated in Figure 6-1.

Volume III presents detailed tracking time history data for the ground stations available for support of this mission. These data consist of range, range rate, azimuth angle, azimuth angle rate, elevation angle, elevation angle rate, and four spacecraft-to-MSFN station look-angles. Volume III data are presented as a function of time for each of the ground stations and annotated for significant mission events.

Table 6-1. MSFN Mission Coverage

MSFN Station	Time from Liftoff (hr:min:sec)		Signal Loss	Total Coverage Time (min:sec)	SLR* MAX (ft)	SLR* MIN (ft)
	Signal Acquisition	Signal Loss				
Cape Kennedy	00:00:00.0	00:07:42.7	07:42.8	3,331,124	18,679	
Grand Bahama	00:01:54.1	00:08:07.0	06:12.9	3,244,243	926,451	
Bermuda	00:06:02.0	00:11:47.7	05:45.8	3,231,478	657,209	
Grand Turk	00:06:43.5	00:07:08.3	00:24.8	3,338,864	3,334,137	
Bermuda Ship	00:09:35.7	00:14:08.4	04:32.7	3,194,890	570,912	
Grand Canary	00:18:08.6	00:22:38.4	04:29.8	3,608,782	1,192,654	
Tananarive	00:38:03.7	00:41:59.1	03:55.4	2,914,962	2,527,745	
Australia Ship	00:48:51.7	00:54:09.5	05:17.9	3,965,140	1,503,678	
Carnarvon	00:53:30.4	00:57:45.4	04:15.0	3,500,131	2,697,829	
Canberra	01:01:20.7	01:04:41.1	03:20.3	3,523,459	3,201,611	
California Ship	01:28:44.6	01:30:52.7	02:08.1	3,352,032	3,391,784	
Guaymas	01:29:57.8	01:34:35.9	04:38.1	3,391,784	836,821	
White Sands	01:31:29.2	01:35:36.3	04:07.1	2,646,470	1,767,133	
Texas	01:33:26.1	01:38:03.6	04:37.5	3,274,785	684,787	
Eglin AFB	01:35:22.1	01:39:58.3	04:36.3	2,495,164	807,146	
Cape Kennedy	01:36:52.8	01:41:12.5	04:19.8	3,201,801	1,318,648	
Grand Bahama	01:37:38.8	01:41:26.7	03:48.0	2,955,516	2,089,469	
Bermuda	01:40:10.7	01:44:51.5	04:40.8	2,299,132	999,907	
Bermuda Ship	01:42:35.4	01:47:08.3	04:33.0	3,250,673	1,076,186	
Tananarive	02:10:29.3	02:15:37.2	05:07.9	3,232,010	1,468,691	

\* Radar Slant Range (SLR)

Table 6-1. MSFN Mission Coverage (Continued)

MSFN Station	Time from Liftoff (hr:min:sec)		Total Coverage Time (min:sec)	SLR* MAX (ft)	SLR* MIN (ft)
	Signal Acquisition	Signal Loss			
Australia Ship	02:22:24.1	02:27:28.2	05:04.1	4,000,867	1,885,811
Carnarvon	02:26:36.9	02:31:39.4	05:02.5	3,564,012	1,869,881
Hawaii	02:52:22.8	02:56:04.3	03:41.5	3,369,725	2,296,500
California Ship	03:00:21.0	03:04:56.9	04:35.8	2,554,325	992,387
Pt. Arguello	03:01:34.9	03:05:34.8	03:59.9	2,919,281	1,889,841
Goldstone	03:02:25.7	03:06:20.9	03:55.1	2,968,132	1,957,666
Guaymas	03:03:17.6	03:07:35.8	04:18.2	2,584,592	1,476,099
White Sands	03:04:13.4	03:08:48.5	04:35.1	2,280,080	928,693
Texas	03:06:41.3	03:11:11.3	04:30.1	3,101,893	911,658
Eglin AFB	03:08:31.6	03:13:09.7	04:38.0	3,191,051	656,493
Cape Kennedy	03:10:01.3	03:14:37.6	04:36.3	2,613,172	843,073
Grand Bahama	03:10:43.2	03:15:03.9	04:20.7	3,308,976	1,288,933
Grand Turk	03:13:16.0	03:16:29.6	03:13.6	2,943,979	2,456,275
Bermuda	03:13:34.6	03:17:17.8	03:43.2	3,138,413	2,242,197
Antigua	03:16:14.2	03:18:36.0	02:21.8	3,018,504	2,945,417
Bermuda Ship	03:16:57.4	03:18:19.2	01:21.8	3,403,460	3,302,883
Ascension Island	03:29:17.9	03:33:13.8	03:55.9	3,473,871	2,390,400
Pretoria	03:40:02.0	03:45:25.8	05:23.8	3,420,932	1,002,243
Australia Ship	03:55:32.2	04:01:00.8	05:28.7	4,003,482	952,885
Carnarvon	03:59:36.0	04:05:06.0	05:29.9	3,935,350	1,117,878
Hawaii	04:24:32.1	04:30:34.1	06:36.1	3,878,750	1,639,688

\* Radar Slant Range (SLR)



Table 6-1. MSFN Mission Coverage (Continued)

MSFN Station	Time from Liftoff		Signal Loss	Total Coverage Time (min:sec)	SLR* MAX (ft)	SLR* MIN (ft)
	Signal Acquisition (hr:min:sec)	Signal Loss (hr:min:sec)				
California Ship	04:33:13.2	04:39:26.9		06:13.7	4,496,325	1,174,066
Pt. Arguello	04:34:05.1	04:40:11.7		06:06.6	4,496,325	1,882,232
Goldstone	04:34:57.7	04:40:57.9		06:00.2	4,496,325	1,677,282
Guaymas	04:36:28.3	04:42:14.6		05:46.3	4,496,325	1,790,793
White Sands	04:37:13.5	04:43:23.7		06:10.3	4,496,325	1,195,068
Texas	04:39:48.4	04:45:54.5		06:06.1	4,496,325	1,283,649
Eglin AFB	04:41:42.2	04:47:54.7		06:12.5	4,496,325	1,198,009
Cape Kennedy	04:43:13.1	04:49:25.1		06:12.1	4,496,325	1,350,875
Grand Bahama	04:43:53.7	04:49:58.1		06:04.5	4,496,325	1,575,536
Grand Turk	04:46:20.3	04:51:35.7		05:15.4	4,496,325	2,693,488
Bermuda	04:46:58.2	04:52:23.9		05:25.7	4,496,325	2,497,014
Antigua	04:49:21.0	04:53:55.3		04:34.2	4,496,325	3,310,282
Bermuda Ship	04:49:57.2	04:54:12.8		04:15.6	4,496,325	3,383,999
Ascension Island	05:03:55.3	05:08:24.6		04:29.3	4,496,325	3,229,155
Prétoria	05:15:01.5	05:20:58.0		05:56.5	4,496,325	1,656,495
Tananarive	05:19:41.6	05:23:59.1		04:17.5	4,496,325	3,344,982
Australia Ship	05:30:37.6	05:36:49.3		06:11.7	3,974,450	1,073,780
Carnarvon	05:34:48.0	05:40:57.5		06:09.5	4,496,325	1,094,010
Hawaii	06:00:13.6	06:06:26.8		06:13.3	4,496,325	1,268,717
California Ship	06:09:04.9	06:15:20.4		06:15.6	4,496,325	1,349,386
Pt. Arguello	06:10:04.8	06:16:04.4		05:59.6	4,496,325	1,884,664

\* Radar Slant Range (SLR)

Table 6-1. MSFN Mission Coverage (Continued)

<u>MSFN Station</u>	<u>Time from Liftoff</u> (hr:min:sec)		<u>Signal Loss</u>	<u>Total Coverage Time</u> (min:sec)	<u>SLR* MAX</u> (ft)	<u>SLR* MIN</u> (ft)
	<u>Signal Acquisition</u>	<u>Signal Loss</u>				
Goldstone	06:10:59.5	06:16:53.1		05:53.7	4,496,325	2,040,322
Guaymas	06:12:17.2	06:18:13.4		05:56.1	4,496,325	1,725,666
White Sands	06:13:10.6	06:19:26.3		06:15.6	4,496,325	1,346,078
Texas	06:15:46.8	06:21:57.5		06:10.8	4,496,325	1,395,963
Eglin AFB	06:17:44.4	06:23:59.1		06:14.7	4,496,325	1,724,623
Cape Kennedy	06:19:18.2	06:25:28.9		06:10.7	4,496,325	1,386,347
Grand Bahama	06:20:00.3	06:26:01.3		06:01.0	4,496,325	1,712,684
Grand Turk	06:22:32.1	06:27:37.7		05:05.5	4,496,325	2,792,044
Bermuda	06:22:58.1	06:28:29.8		05:31.6	4,496,325	2,356,022
Antigua	06:25:32.1	06:29:59.9		04:27.8	4,496,325	3,279,910
Bermuda Ship	06:25:55.4	06:30:16.9		04:21.5	4,496,325	3,309,546
Ascension Island	06:39:43.1	06:44:38.3		04:55.1	4,496,325	2,878,200
Pretoria	06:50:51.0	06:56:57.1		06:06.2	4,496,325	1,298,718
Tananarive	06:55:59.5	06:59:27.1		03:27.6	4,160,380	3,787,123
Australia Ship	07:06:36.0	07:12:46.1		06:10.1	4,496,325	1,599,480
Carnarvon	07:10:46.1	07:16:56.6		06:10.5	4,496,325	1,175,675
Hawaii	07:36:44.2	07:42:51.3		06:07.0	4,496,325	1,614,300
California Ship	07:45:40.4	07:51:55.5		06:15.0	4,496,325	1,326,300
Pt. Arguello	07:46:35.3	07:52:36.8		06:01.5	4,496,325	1,799,403
Goldstone	07:47:29.2	07:53:21.6		05:52.4	4,496,325	2,100,480
Guaymas	07:48:58.1	07:55:00.2		06:02.1	4,496,325	2,179,453

\* Radar Slant Range (SLR)

Table 6-1. MSFN Mission Coverage (Continued)

MSFN Station	Time from Liftoff		Signal Loss	Total Coverage Time (min:sec)	SLR* <sub>MAX</sub> (ft)	SLR* <sub>MIN</sub> (ft)
	Signal Acquisition (hr:min:sec)	Signal Loss (hr:min:sec)				
White Sands	07:49:45.9	07:55:56.6	06:10.7	4,496,325	1,418,399	
Texas	07:52:23.4	07:58:36.7	06:13.3	4,496,325	1,450,808	
Eglin AFB	07:54:25.5	08:00:18.5	05:53.0	4,496,325	1,934,534	
Cape Kennedy	07:55:59.1	08:01:51.3	05:52.1	4,496,325	1,886,711	
Grand Bahama	07:56:35.3	08:02:37.1	06:01.8	4,496,325	1,651,083	
Grand Turk	07:58:40.9	08:04:54.0	06:13.0	4,496,325	1,240,856	
Antigua	08:01:19.4	08:07:31.0	06:11.6	4,496,325	1,330,680	
Ascension Island	08:15:42.8	08:21:17.2	05:34.4	4,177,565	2,257,699	
Pretoria	08:27:18.0	08:33:10.6	05:52.6	4,312,824	1,726,340	
Australia Ship	08:43:04.6	08:48:34.4	05:29.8	4,496,325	2,298,076	
Carnarvon	08:49:05.9	08:50:26.9	01:21.1	4,496,325	4,367,711	
Guam	08:59:26.9	09:05:15.5	05:48.7	4,496,325	2,045,031	
Hawaii	09:14:19.4	09:18:42.9	04:23.5	4,496,325	3,413,978	
California Ship	09:22:05.1	09:28:18.0	06:12.8	4,496,325	1,334,788	
Pt. Arguello	09:22:58.9	09:28:31.0	05:32.1	4,496,325	2,382,019	
Goldstone	09:23:59.2	09:29:00.2	05:01.0	4,496,325	2,911,133	
Guaymas	09:25:19.5	09:31:31.9	06:12.3	4,496,325	1,499,135	
White Sands	09:26:26.8	09:31:31.8	05:04.9	4,496,325	2,751,529	
Texas	09:29:22.1	09:33:50.8	04:28.7	4,496,325	3,246,177	
Pretoria	10:03:59.8	10:09:31.0	05:31.1	4,186,233	2,248,454	
Tananarive	10:09:57.6	10:13:20.3	03:22.7	4,226,661	3,815,759	

\* Radar Slant Range (SLR)

Table 6-1. MSFN Mission Coverage (Continued)

MSFN Station	Time from Liftoff		Signal Loss	Total Coverage Time (min:sec)	SLR* MAX (ft)	SLR* MIN (ft)
	Signal Acquisition (hr:min:sec)	Signal Loss (hr:min:sec)				
Guam	10:36:13.2	10:41:13.2	05:00.0	4,496,325	2,819,782	
Hawaii	10:51:37.5	10:55:24.5	03:47.0	4,496,325	3,642,607	
California Ship	10:58:53.5	11:03:44.2	04:50.6	4,496,325	2,987,050	
Guaymas	11:02:48.1	11:06:12.1	03:24.0	4,496,325	3,845,032	
Pretoria	11:40:27.3	11:45:53.4	05:26.2	3,175,954	1,095,662	
Tananarive	11:45:21.7	11:50:50.3	05:28.6	3,150,089	1,840,544	
Hawaii	12:26:34.8	12:32:15.4	05:40.7	4,496,325	2,246,888	
Pretoria	13:15:56.1	13:20:49.2	04:53.1	3,783,021	2,098,560	
Tananarive	13:21:12.4	13:25:18.1	04:05.7	4,098,072	3,016,446	

\* Radar Slant Range (SLR)

Table 6-2. Communication Void Intervals

<u>Void Begins Time from Liftoff (hr:min:sec)</u>	<u>Void Ends Time from Liftoff (hr:min:sec)</u>	<u>Void Duration (min:sec)</u>
00:14:08	00:18:09	04:01
00:22:38	00:48:52	26:16
00:57:45	01:28:45	31:00
01:47:08	02:22:24	35:16
02:31:39	02:52:23	20:44
02:56:04	03:00:21	04:17
03:18:19	03:29:18	10:59
03:33:14	03:40:02	06:48
03:45:26	03:55:31	10:05
04:05:06	04:24:32	19:26
04:30:34	04:33:13	03:39
04:54:13	05:03:55	09:42
05:08:25	05:15:02	06:37
05:23:59	05:30:38	06:39
05:40:58	06:00:14	19:16
06:06:27	06:09:05	02:38
06:30:17	06:39:43	09:26
06:44:38	06:50:51	06:13
06:59:27	07:06:36	07:09
07:16:57	07:36:44	19:47
07:42:51	07:45:40	02:49
08:07:31	08:15:43	08:12
08:21:17	08:27:18	06:01
08:33:11	08:43:05	09:54
08:50:27	08:59:27	09:00
09:05:16	09:14:19	09:03
09:18:43	09:22:05	03:22
09:33:51	10:04:00	30:09
10:13:20	10:36:13	22:53
10:41:13	10:51:38	10:25
10:55:25	10:58:54	03:29

Table 6-2. Communication Void Intervals (Continued)

<u>Void Begins Time from Liftoff (hr:min:sec)</u>	<u>Void Ends Time from Liftoff (hr:min:sec)</u>	<u>Void Duration (min:sec)</u>
11:06:12	11:40:27	34:15
11:50:50	12:26:35	35:45
12:32:15	13:15:56	43:41
13:20:49	13:21:12	00:23
13:25:18	14:00:00*	34:42

\* End of mission profile.

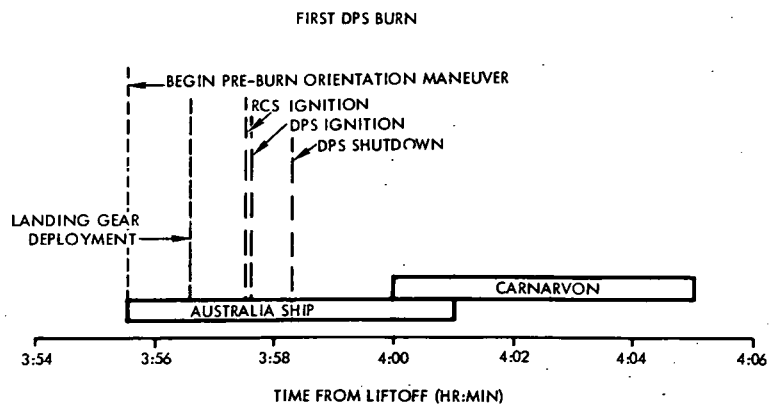
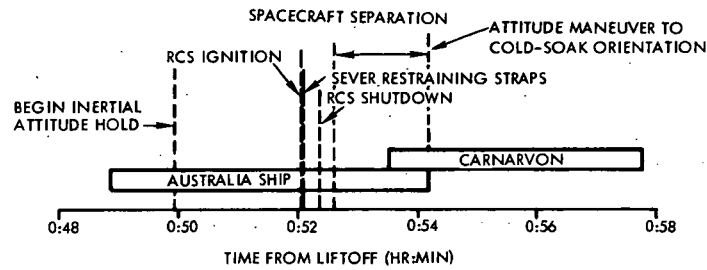
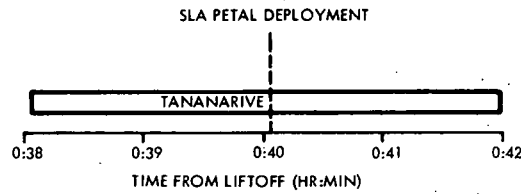
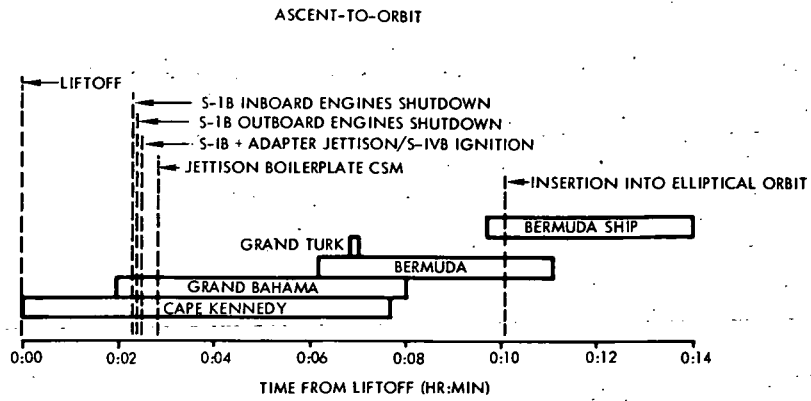

Figure 6-1. MSFN Coverage Summary

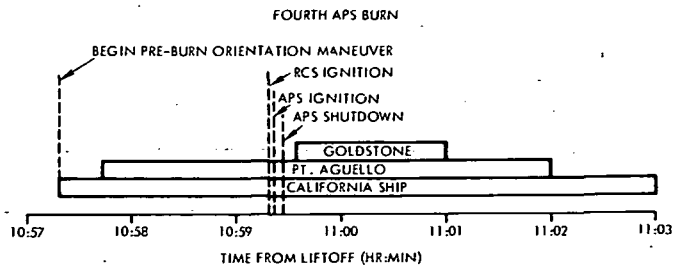
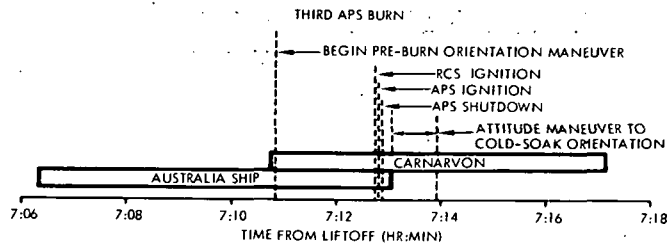
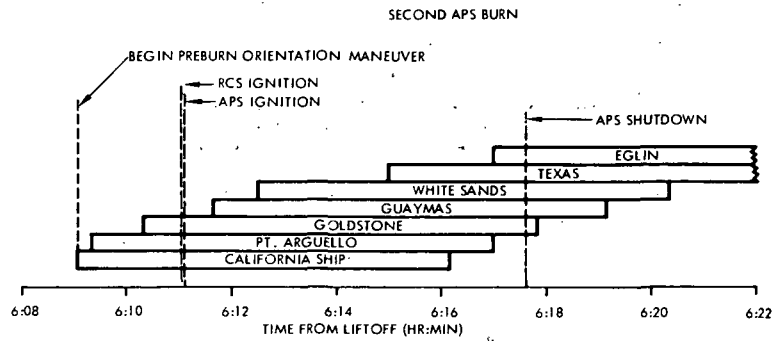
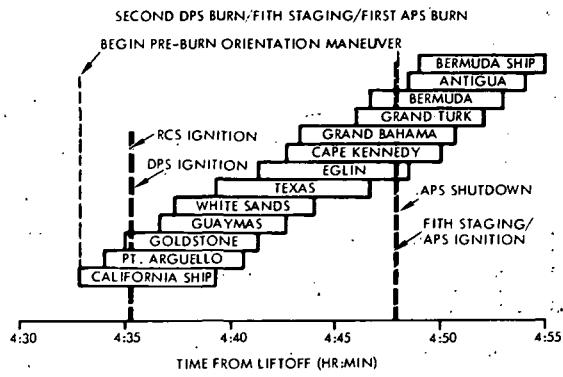

Figure 6-1. MSFN Coverage Summary (Continued)



## 7. SUMMARY OF TECHNICAL ACHIEVEMENT

This report contains no innovations or improvements involving new technology, approaches, methods, or patentable ideas as defined in the contract's "New Technology and Property Rights in Inventions" clause.

## REFERENCES

1. "Mission Requirements for Apollo Spacecraft Development Mission AS-206A," TRW No. 2132-H004-RU-000, 1 December 1965.
2. R. K. Petersburg, "Apollo Mission SA-206A Spacecraft Preliminary Reference Trajectory (U)," TRW No. 3300-H007-RC000, 1 July 1965. (C)
3. "Apollo AS-206A Trajectory Listing," furnished MSC by MSFC through the Guidance and Performance Subpanel.
4. "Apollo Navigation Working Group," NASA No. 65-AN-1.0, 5 February 1965.
5. "Operational Support Plan for the Apollo 200 Series Missions," Prepared by the Flight Control Division/MSFC, April 1965.
6. A. Kelemen, "The LEM-1 Mission Capability Report NASA Mission AS-206A (U)," No. LED-540-41, 1 November 1965. (C)
7. Minutes of Flight Operations Plan, Meetings 1 through 12.
8. "Apollo Mission Data Specification C Apollo-Saturn 206A (U)," TRW No. 2131-6002-TC000, 5 November 1965. (C)
9. "Launch Vehicle Reference Trajectory," MSFC, to be published.
10. "Lifetime of Near Earth Satellites in Circular or Elliptical Orbits," Memorandum for Record, OFO (JCB:jec), 13 September 1963. (C)
11. "Apollo Guidance and Navigation, G and N System Operations Plan Mission AS-206," MIT Instrumentation Laboratory No. R-527, November 1965. (C)