

Orbit Pocket Checklist

Mission Operations Directorate Operations Division

Generic, Rev M
October 18, 2006

NOTE

For STS-116 and subsequent flights

AESP: MM101

APCL: MM104

OPCL: MM106

EPCL: MM301

AESP: MM304

National Aeronautics and
Space Administration

Lyndon B. Johnson Space Center
Houston, Texas



United Space Alliance

ORBIT POCKET CHECKLIST

GENERIC, Rev M (Oct 18, 2006)

PCN-10 (May 15, 2009) Sheet 1 of 1

List of Implemented Change Requests (482s):

OPCL-0520

NOTE

For STS-127 and subsequent flights

Incorporate the following:

1. Replace v thru viii
2. Replace A4-1 thru B4-2 (4 pages)
3. Replace A10-73 thru A10-82
4. Replace B10-81 and B10-82

Prepared by: Mary Ellen S. McA
Publication Manager

Approved by: Lynne Langham for
Manager, Flight Procedures

Accepted by: Steve P.
FDF Manager

Encl: 20 pages

File this PCN immediately behind the front cover as a permanent record

ORBIT POCKET CHECKLIST	GENERIC, Rev M (Oct 18, 2006)
-------------------------------	--------------------------------------

PCN-9 (Jan 16, 2009) Sheet 1 of 1

List of Implemented Change Requests (482s):

MULTI-1833 OPCL-506

<p style="text-align: center;">NOTE For STS-119 and subsequent flights</p>

Incorporate the following:

- 1. Replace v thru x
- 2. Replace 3-1 and 3-2
- 3. Replace 8-7 and 8-8

Prepared by: Carol H. Pierce
Publication Manager

Approved by: Imberly Mason
Manager, Shuttle Procedures Management

Accepted by: Michael T. L...
FDF Manager

Encl: 10 pages

File this PCN immediately behind the front cover as a permanent record

ORBIT POCKET CHECKLIST	GENERIC, Rev M (Oct 18, 2006)
------------------------	-------------------------------

PCN-8 (Oct 14, 2008) Sheet 1 of 1

List of Implemented Change Requests (482s):

MULTI-1829

NOTE
For STS-126 and subsequent flights

Incorporate the following:

- 1. Replace v and vi
- 2. Replace 3-7 and 3-8

Prepared by: Mary Ellen Bruce
Publication Manager

Approved by: STP.P. [Signature]
Manager, Shuttle Procedures Management

Accepted by: [Signature]
RDF Manager

Encl: 4 pages

File this PCN immediately behind the front cover as a permanent record

ORBIT POCKET CHECKLIST

GENERIC, Rev M (Oct 18, 2006)

PCN-6 (Apr 24, 2008) Sheet 1 of 1

List of Implemented Change Requests (482s):

MULTI-1813 OPCL-0503
MULTI-1818**NOTE**

For STS-124 and subsequent flights

Incorporate the following:

1. Replace v thru viii
2. Replace 3-9 and 3-10
3. Replace A10-5 and A10-6, A10-21 and A10-22, A10-35 and A10-36, A10-43 and A10-44, A10-47 and A10-48, A10-57 and A10-58, A10-63 and A10-64
4. Replace B10-5 and B10-6, B10-21 and B10-22, B10-35 and B10-36, B10-43 and B10-44, B10-47 and B10-48, B10-57 and B10-58, B10-63 and B10-64
5. Replace 11-9 and 11-10

Prepared by: Mary Ellen Luce
Publication ManagerApproved by: James H. Haggan for
Manager, Shuttle Procedures ManagementAccepted by: Emberly Johnson for
FDF Manager

Encl: 36 pages

File this PCN immediately behind the front cover as a permanent record

ORBIT POCKET CHECKLIST

GENERIC, Rev M (Oct 18, 2006)

PCN-5 (Jan 15, 2008) Sheet 1 of 1

List of Implemented Change Requests (482s):

MULTI-1812A OPCL-0502
MULTI-1814**NOTE**

For STS-123 and subsequent flights

Incorporate the following:

1. Replace v thru x, xiii and xiv
2. Replace 4-13 and 4-14, 4-17 and 4-18
3. Replace A6-1 thru B6-4 (8 pages)

Prepared by: Mary Ellen Bruce
Publication ManagerApproved by: Ember Johnson
Manager, Shuttle Procedures ManagementAccepted by: Michael J. Holt
FDF Manager

Encl: 20 pages

File this PCN immediately behind the front cover as a permanent record

ORBIT POCKET CHECKLIST

GENERIC, Rev M (Oct 18, 2006)

PCN-4 (Sept 26, 2007) Sheet 1 of 1

List of Implemented Change Requests (482s):

MULTI-1803

NOTE

For STS-120 and subsequent flights

Incorporate the following:

1. Replace v and vi
2. Replace 4-13 and 4-14
Delete TEMP 4-13 and TEMP 4-14

Prepared by: Mary Ellen Bruce
Publication Manager

Approved by: Gymbals Johnson
Manager, Shuttle Procedures Management

Accepted by: Michael E. Shaw
FDF Manager

Encl: 4 pages

File this PCN immediately behind the front cover as a permanent record

ORBIT POCKET CHECKLIST

GENERIC, Rev M (Oct 18, 2006)

PCN-3 (Sept 20, 2007) Sheet 1 of 1

List of Implemented Change Requests (482s):

MULTI-1798 OPCL-0494
 OPCL-0497A
 OPCL-0498
 OPCL-0499
 OPCL-0500
 OPCL-0501

NOTE
For STS-120 and subsequent flights

Incorporate the following:

1. Replace v thru viii, xi and xii
2. Replace 4-17 thru 4-24
3. Replace A10-23 and A10-24, A10-29 and A10-30, A10-35 and A10-36, A10-39 and A10-40, A10-43 and A10-44, A10-47 and A10-48, A10-61 and A10-62, A10-71 and A10-72
4. Replace B10-23 and B10-24, B10-29 and B10-30, B10-35 and B10-36, B10-39 and B10-40, B10-43 and B10-44, B10-47 and B10-48, B10-61 and B10-62, B10-71 and B10-72
5. Replace 11-7 and 11-8

Prepared by: Mary Ellen Lrua
 Publication Manager

Approved by: Kimberly Johnson
 Manager, Shuttle Procedures Management

Accepted by: Michael E. Shaw
 FDF Manager

Encl: 48 pages

File this PCN immediately behind the front cover as a permanent record

ORBIT POCKET CHECKLIST

GENERIC, Rev M (Oct 18, 2006)

PCN-2 (July 16, 2007) Sheet 1 of 1

List of Implemented Change Requests (482s):

MULTI-1738A(R)	OPCL-0492
MULTI-1785	OPCL-0493
MULTI-1786	OPCL-0495
MULTI-1790	OPCL-0496
MULTI-1792	

NOTE

For STS-118 and subsequent flights

R – Remainder

Incorporate the following:

1. Replace v thru x
2. Replace 1-3 and 1-4
3. Replace B4-1 and B4-2, 4-5 thru B4-8 (6 pages), 4-21 thru 4-24
4. Replace 5-1 thru 5-4, 5-7 and 5-8
5. Replace A10-61 and A10-62
6. Replace B10-61 and B10-62, B10-73 thru B10-80

Prepared by: Mary Ellen Krue
Publication Manager

Approved by: Amber Johnson
Manager, Shuttle Procedures Management

Accepted by: Michael T. Holt
FDF Manager

Encl: 38 pages

File this PCN immediately behind the front cover as a permanent record

ORBIT POCKET CHECKLIST

GENERIC, Rev M (Oct 18, 2006)

PCN-1 (Feb 7, 2007) Sheet 1 of 1

List of Implemented Change Requests (482s):

MULTI-1756
MULTI-1769
MULTI-1774**NOTE**

For STS-117 and subsequent flights

Incorporate the following:

1. Replace v thru x
2. Replace 4-13 and 4-14
After 4-14, add TEMP 4-13 and TEMP 4-14
3. Replace A10-27 and A10-28
4. Replace B10-27 and B10-28

Prepared by: Mary Ellen Krue
Publication ManagerApproved by: Timothy Johnson
Manager, Shuttle Procedures ManagementAccepted by: Michael E. Shaw
FDF Manager

Encl: 14 pages

File this PCN immediately behind the front cover as a permanent record

MISSION OPERATIONS DIRECTORATE

ORBIT POCKET CHECKLIST

GENERIC, REVISION M

October 18, 2006

PREPARED BY:



Mary E. Bruce
Publication Manager

APPROVED BY:

ACCEPTED BY:

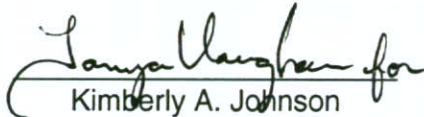

Kimberly A. Johnson
Manager, Shuttle
Procedures Management



Michael T. Hurt
FDF Manager

This document is under the configuration control of the Crew Procedures Control Board (CPCB). All proposed changes must be submitted via FDF Workflow Crew Procedure Change Request (CR) to DO3/FDF Manager.

Additional distribution of this book, for official use only, may be requested in writing to DO3/PMO Administrator. The request must include justification and requester's name, organization, position, and phone number. Contractor requests are made through the NASA or DOD organization supported. Deletions, reduction in quantity, or change of address may be submitted to DO3/FDF Management Office, 281-244-1184.

Incorporates the following:		
482#:	MULTI-1755	OPCL-0489A
	MULTI-1763	OPCL-0490A
	MULTI-1766	OPCL-0491
	MULTI-1768	

AREAS OF TECHNICAL RESPONSIBILITY

Publication Manager	DO35/M. Bruce	281-483-6083
Alternate	DO35/C. Pierce	281-483-6087
APU/HYD	DF5/J. Jason	281-483-7575
COMM	DF2/J. McKinnie	281-483-0792
DPS	DF3/J. McDonald	281-483-0793
ECLS	DF8/D. Fasbender	281-483-7857
EPS	DF7/M. Friant	281-483-0682
GNC	DF6/D. Gruber	281-483-0709
OMS/RCS	DF6/T. Campa	281-244-1002
MPS	DF5/M. Patel	281-244-0083
PWRDN	DF7/M. Friant	281-483-0682

NOTES

1. The pocket checklists contain contingency procedures to safe a system and continue the flight. Normally, these procedures do not troubleshoot a malfunction to determine its cause.
2. The absence of a procedure implies no immediate action required. The crewmember should proceed to the MAL book as soon as practical.
3. The Orbit Pocket Checklist is generally constrained to include only those procedures that can and must be performed within 5 minutes. All procedures should be completed promptly in the step sequence noted. For longer or less time-critical procedures during the orbit phase, the Malfunction Procedures (MAL) book is available.
4. The procedures in this book are in effect from MM106 transition until transition to MM301 for deorbit.
5. During all on-orbit OMS burns (from TIG-2 min to achievement of required velocity), appropriate OMS and related critical malfunction symptoms and response data are covered by cue cards. For all other on-orbit time periods, OMS procedures contained in this document apply.
6. Critical malfunction symptoms and response data for other orbiter systems are handled by cue cards (if existing), otherwise by procedures included herein.
7. Applicable procedures from the PL PWR book (i.e., Sections 2 and 3) are placed at the end of the flight copies of this book.
8. The '♦' icon preceding a procedural entry indicates one should √MCC and if no comm continue with the procedure.



This Page Intentionally Blank



ORBIT POCKET CHECKLIST

LIST OF EFFECTIVE PAGES

GENERIC	04/07/87	PCN-5	01/15/08
REV M	10/18/06	PCN-6	04/24/08
PCN-1	02/07/07	PCN-7	08/11/08
PCN-2	07/16/07	PCN-8	10/14/08
PCN-3	09/20/07	PCN-9	01/16/09
PCN-4	09/26/07	PCN-10	05/15/09

Sign Off	*	ALL/GEN M	3-11.....	ALL/GEN M
ii	*	ALL/GEN M	3-12.....	ALL/GEN M
iii.....	*	ALL/GEN M	3-13.....	ALL/GEN M
iv	*	ALL/GEN M	3-14.....	ALL/GEN M
v	*	ALL/GEN M,10	A4-1	3,4/GEN M,10
vi	*	ALL/GEN M,9	A4-2	ALL/GEN M
vii	*	ALL/GEN M,10	B4-1	5/GEN M,10
viii.....	*	ALL/GEN M,10	B4-2	ALL/GEN M
ix	*	ALL/GEN M,9	4-3.....	ALL/GEN M,7
x	*	ALL/GEN M	4-4.....	ALL/GEN M
xi	*	ALL/GEN M	4-5.....	ALL/GEN M
xii	*	ALL/GEN M,3	4-6.....	ALL/GEN M,2
xiii.....	*	ALL/GEN M,5	A4-7	ALL/GEN M,2
xiv	*	ALL/GEN M	A4-8	ORB/GEN M
1-1		ALL/GEN M	B4-7	ALL/GEN M,2
1-2.....		ALL/GEN M	B4-8	SHM/GEN M
1-3.....		ALL/GEN M,2	4-9.....	ALL/GEN M
1-4		ALL/GEN M	4-10.....	ALL/GEN M
2-1		ALL/GEN M	A4-11	ALL/GEN M
2-2.....		ALL/GEN M	A4-12	3,4/GEN M
2-3.....		ALL/GEN M	B4-11	ALL/GEN M
2-4		ALL/GEN M	B4-12	5/GEN M
3-1		ALL/GEN M	4-13.....	ALL/GEN M
3-2.....		ALL/GEN M,9	4-14.....	ALL/GEN M,5
3-3.....		ALL/GEN M	4-15.....	ALL/GEN M
3-4.....		ALL/GEN M	4-16.....	ALL/GEN M
3-5.....		ALL/GEN M,7	4-17.....	ALL/GEN M,5
3-6.....		ALL/GEN M	4-18.....	ALL/GEN M,3
3-7		ALL/GEN M,8	4-19.....	ALL/GEN M
3-8.....		ALL/GEN M	4-20.....	ALL/GEN M
3-9.....		ALL/GEN M,6	4-21.....	ALL/GEN M
3-10.....		ALL/GEN M	4-22.....	ALL/GEN M,7

* – Omit from flight book

4-23.....	ALL/GEN M,3	5-41.....	ALL/GEN M
4-24.....	ALL/GEN M	5-42.....	ALL/GEN M
5-1.....	ALL/GEN M	5-43.....	ALL/GEN M
5-2.....	ALL/GEN M,2	5-44.....	ALL/GEN M
5-3.....	ALL/GEN M,2	A6-1.....	ALL/GEN M
5-4.....	ALL/GEN M	A6-2.....	3,4/GEN M,5
5-5.....	ALL/GEN M	A6-3.....	3,4/GEN M,5
5-6.....	ALL/GEN M	A6-4.....	3,4/GEN M,5
5-7.....	ALL/GEN M	B6-1.....	ALL/GEN M
5-8.....	ALL/GEN M,2	B6-2.....	5/GEN M,5
5-9.....	ALL/GEN M	B6-3.....	5/GEN M,5
5-10.....	ALL/GEN M	B6-4.....	5/GEN M,5
5-11.....	ALL/GEN M	7-1.....	ALL/GEN M
5-12.....	ALL/GEN M	7-2.....	ALL/GEN M
5-13.....	ALL/GEN M	7-3.....	ALL/GEN M
5-14.....	ALL/GEN M	7-4.....	ALL/GEN M
5-15.....	ALL/GEN M	7-5.....	ALL/GEN M
5-16.....	ALL/GEN M	7-6.....	ALL/GEN M
5-17.....	ALL/GEN M	7-7.....	ALL/GEN M
5-18.....	ALL/GEN M	7-8.....	ALL/GEN M
5-19.....	ALL/GEN M	7-9.....	ALL/GEN M
5-20.....	ALL/GEN M	7-10.....	ALL/GEN M
5-21.....	ALL/GEN M	8-1.....	ALL/GEN M
5-22.....	ALL/GEN M	8-2.....	ALL/GEN M
5-23.....	ALL/GEN M	8-3.....	ALL/GEN M
5-24.....	ALL/GEN M	8-4.....	ALL/GEN M
5-25.....	ALL/GEN M	8-5.....	ALL/GEN M
5-26.....	ALL/GEN M	8-6.....	ALL/GEN M
5-27.....	ALL/GEN M	8-7.....	ALL/GEN M,9
5-28.....	ALL/GEN M	8-8.....	ALL/GEN M
5-29.....	ALL/GEN M	8-9.....	ALL/GEN M
5-30.....	ALL/GEN M	8-10.....	ALL/GEN M
5-31.....	ALL/GEN M	9-1.....	ALL/GEN M
5-32.....	ALL/GEN M	9-2.....	ALL/GEN M
5-33.....	ALL/GEN M	A10-1.....	ALL/GEN M
5-34.....	ALL/GEN M	A10-2.....	ALL/GEN M
5-35.....	ALL/GEN M	A10-3.....	ALL/GEN M
5-36.....	ALL/GEN M	A10-4.....	ALL/GEN M
5-37.....	ALL/GEN M	A10-5.....	ALL/GEN M,6
5-38.....	ALL/GEN M	A10-6.....	ALL/GEN M
5-39.....	ALL/GEN M	A10-7.....	ALL/GEN M
5-40.....	ALL/GEN M	A10-8.....	ALL/GEN M

A10-9.....	3,4/GEN M	A10-51	3,4/GEN M
A10-10	ALL/GEN M	A10-52	ALL/GEN M
A10-11	ALL/GEN M	A10-53	ALL/GEN M
A10-12	ALL/GEN M	A10-54	ALL/GEN M
A10-13	ALL/GEN M	A10-55	ALL/GEN M
A10-14	ALL/GEN M	A10-56	ALL/GEN M
A10-15	ALL/GEN M	A10-57	ALL/GEN M,6
A10-16	ALL/GEN M	A10-58	ALL/GEN M
A10-17	ALL/GEN M	A10-59	ALL/GEN M
A10-18	ALL/GEN M	A10-60	ALL/GEN M
A10-19	3,4/GEN M	A10-61	3,4/GEN M,2
A10-20	ALL/GEN M	A10-62	3,4/GEN M,3
A10-21	ALL/GEN M,6	A10-63	ALL/GEN M
A10-22	ALL/GEN M	A10-64	ALL/GEN M,6
A10-23	ALL/GEN M	A10-65	ALL/GEN M
A10-24	ALL/GEN M,3	A10-66	ALL/GEN M
A10-25	ALL/GEN M	A10-67	ALL/GEN M
A10-26	ALL/GEN M	A10-68	ALL/GEN M
A10-27	3,4/GEN M	A10-69	3,4/GEN M
A10-28	ALL/GEN M,1	A10-70	ALL/GEN M
A10-29	ALL/GEN M	A10-71	ALL/GEN M,3
A10-30	ALL/GEN M,3	A10-72	ALL/GEN M
A10-31	3,4/GEN M	A10-73	ALL/GEN M
A10-32	3,4/GEN M	A10-74	3,4/GEN M,10
A10-33	3,4/GEN M	A10-75	3,4/GEN M,10
A10-34	3,4/GEN M	A10-76	ALL/GEN M
A10-35	3,4/GEN M	A10-77	ALL/GEN M
A10-36	ALL/GEN M,6	A10-78	3,4/GEN M,10
A10-37	3,4/GEN M	A10-79	3,4/GEN M,10
A10-38	3,4/GEN M	A10-80	ALL/GEN M
A10-39	3,4/GEN M,3	A10-81	3,4/GEN M,10
A10-40	3,4/GEN M	A10-82	3,4/GEN M,10
A10-41	3,4/GEN M	B10-1	ALL/GEN M
A10-42	ALL/GEN M	B10-2	ALL/GEN M
A10-43	ALL/GEN M,6	B10-3	ALL/GEN M
A10-44	ALL/GEN M	B10-4	ALL/GEN M
A10-45	3,4/GEN M	B10-5	ALL/GEN M,6
A10-46	ALL/GEN M	B10-6	ALL/GEN M
A10-47	ALL/GEN M,6	B10-7	ALL/GEN M
A10-48	ALL/GEN M	B10-8	ALL/GEN M
A10-49	ALL/GEN M	B10-9	5/GEN M
A10-50	ALL/GEN M	B10-10	ALL/GEN M

B10-11	ALL/GEN M	B10-51	5/GEN M
B10-12	ALL/GEN M	B10-52	ALL/GEN M
B10-13	ALL/GEN M	B10-53	ALL/GEN M
B10-14	ALL/GEN M	B10-54	ALL/GEN M
B10-15	ALL/GEN M	B10-55	ALL/GEN M
B10-16	ALL/GEN M	B10-56	ALL/GEN M
B10-17	ALL/GEN M	B10-57	ALL/GEN M,6
B10-18	ALL/GEN M	B10-58	ALL/GEN M
B10-19	5/GEN M	B10-59	ALL/GEN M
B10-20	ALL/GEN M	B10-60	ALL/GEN M
B10-21	ALL/GEN M,6	B10-61	5/GEN M,2
B10-22	ALL/GEN M	B10-62	5/GEN M,3
B10-23	ALL/GEN M	B10-63	ALL/GEN M
B10-24	ALL/GEN M,3	B10-64	ALL/GEN M,6
B10-25	ALL/GEN M	B10-65	ALL/GEN M
B10-26	ALL/GEN M	B10-66	ALL/GEN M
B10-27	5/GEN M	B10-67	ALL/GEN M
B10-28	ALL/GEN M,1	B10-68	ALL/GEN M
B10-29	ALL/GEN M	B10-69	5/GEN M
B10-30	ALL/GEN M,3	B10-70	ALL/GEN M
B10-31	5/GEN M	B10-71	ALL/GEN M,3
B10-32	5/GEN M	B10-72	ALL/GEN M
B10-33	5/GEN M	B10-73	ALL/GEN M
B10-34	5/GEN M	B10-74	5/GEN M,2
B10-35	5/GEN M	B10-75	5/GEN M,2
B10-36	ALL/GEN M,6	B10-76	ALL/GEN M
B10-37	5/GEN M	B10-77	ALL/GEN M
B10-38	5/GEN M	B10-78	5/GEN M,2
B10-39	5/GEN M,3	B10-79	5/GEN M,2
B10-40	5/GEN M	B10-80	ALL/GEN M
B10-40a	5/GEN M	B10-81	5/GEN M,10
B10-40b	5/GEN M	B10-82	5/GEN M,10
B10-41	5/GEN M	A11-1	ALL/GEN M
B10-42	ALL/GEN M	A11-2	3,4/GEN M
B10-43	ALL/GEN M,6	A11-3	3,4/GEN M
B10-44	ALL/GEN M	A11-4	ALL/GEN M
B10-45	5/GEN M	B11-1	ALL/GEN M
B10-46	ALL/GEN M	B11-2	5/GEN M
B10-47	ALL/GEN M,6	B11-3	5/GEN M
B10-48	ALL/GEN M	B11-4	ALL/GEN M
B10-49	ALL/GEN M	11-5	ALL/GEN M
B10-50	ALL/GEN M	11-6	ALL/GEN M

11-7.....	ALL/GEN M,3
11-8.....	ALL/GEN M
11-9.....	ALL/GEN M,6
11-10.....	ALL/GEN M
11-11.....	ALL/GEN M
11-12.....	ALL/GEN M
12-1.....*	ALL/GEN M
CC 12-2.....⊗*	ALL/GEN M
CC 12-3.....*	ALL/GEN M
CC 12-4.....*	ALL/GEN M
CC 12-5.....*	ALL/GEN M
CC 12-6.....*	ALL/GEN M
CC 12-7.....*	ODS/GEN M
12-8.....*	ALL/GEN M

* – Omit from flight book
 ⊗ – Highlights reqd

ORBIT POCKET CHECKLIST CUE CARDS

<u>Title</u>	<u>Ref. Page</u>	<u>Card No.</u>
LEAKING OMS PRPLT/ He BURN		
(Front)	CC 12-2	OPCL-1a/O/G
(Back).....	CC 12-3	OPCL-1b/O/B
HAZARDOUS SPILL RESPONSE – ORBITER		
(Front)	CC 12-4	OPCL-2a/O/L
(Back).....	CC 12-5	OPCL-2b/O/J
FIRE/SMOKE		
(ASCENT/ENTRY) (Front).....	See ASC/ENT SYS PROC	
(ORBIT) (Back)	CC 12-6	OPCL-7b/A,O,E/K
ODS VOLUME FIRE/SMOKE		
(Front)	CC 12-7	OPCL-3a/ODS/O/I
(Back).....	CC 12-7	OPCL-3b/ODS/O/E

<u>CONTENTS</u>	<u>PAGE</u>
<u>APU/HYD</u>	
APU/HYD SCHEMATIC.....	1-1
HYD ACCUM (RSVR) P LOW (CIL).....	1-2
CIRC PUMP PRESS LOW	1-2
APU FUEL SUPPLY T.....	1-3
PUMP T.....	1-3
WATER T	1-3
<u>COMM</u>	
PWRUP.....	2-1
BCE BYP KU	2-1
ICOM LOST	2-2
S76 COMM PA 2(1) TEMP.....	2-2
PA 2(1) OUTPUT LOW	2-2
NSP 2(1) BITE.....	2-2
COMSEC 2(1) BITE	2-2
COMM LOST	2-3
UHF COMM LOST.....	2-4
<u>DPS</u>	
ALL IDPs ASSIGNED TO FAILED GPC	3-2
DUAL DPS DISPLAY COMMANDERS	3-2
BFS ENGAGE	3-2
SUMWORD ICC 1(2,3,4).....	3-3
BCE STRG X	3-4
PL1(2) MDM I/O ERROR; OUTPUT.....	3-5
FF(FA) MDM OUTPUT	3-6
I/O ERROR	3-7
PASS GNC GPC (1st FAIL)	3-8
SM GPC FAIL	3-9
GPC BITE 1(2,3,4).....	3-11
GNC RECOVERY VIA G2FD	3-12
<u>ECLS</u>	
EQUIPMENT COOLING MATRIX.....	4-1
O2(N2) FLOW HIGH/CAB P LOW/dP/dT.....	4-3
CABIN PRESS LEAK NOMOGRAPH	4-8
N2 DEPLETION GRAPH	4-10
H2O TK QTY LOW AND DECR	4-11
EVAP OUT T HIGH	4-11
EMER PLBD OPENING	4-13
EVAP OUT T LOW	4-14
H2O SPLY PRESS HIGH.....	4-15
FREON FLOW LOW.....	4-16

<u>CONTENTS (Cont)</u>	<u>PAGE</u>
FREON LOOP RAD OUT T LOW	4-17
LEAK	4-17
LEAKING/EMPTY HALON BOTTLE	4-18
ODS POST-FIRE ACTIONS.....	4-19
POST-FIRE CABIN CLEANUP	4-22
ISS C&W TOX ATM.....	4-23
PRESSURE CONTROL SYSTEM SCHEMATIC	4-24

EPS

MN BUS UNDERVOLTS/FC VOLTS (CIL)	5-2
3Φ AC MOTORS STOPPED	5-4
AC VOLTS	5-5
OVERLOAD	5-7
ESS BUS VOLTS LOW (CIL)	5-8
CNTL BUS V LOW/CNTL BUS RPC	5-9
FC COOLANT PUMP ΔP LOW (CIL)	5-11
FC1(2,3) H2 PUMP ↑↓	5-11
FC REACTANT VLV CLOSED	5-12
COOL P (CIL)	5-12
H2O RLF NOZ TEMP ↑↓	5-13
DELTA V 1(2,3) (CIL).....	5-14
pH HIGH or H2O LINE pH HIGH	5-14
SHUTDN (1st) (CIL).....	5-15
2nd FC SHUTDN	5-15
BUS TIE (CIL)	5-16
FC SAFING	5-16
CRYO O2(H2) PRESS/TEMP HIGH	5-17
LEAK	5-17
SCHEMATIC	5-19
O2/H2 HTR LOSS	5-20
BUS LOSS IDENTIFICATION TABLES	5-21
ACTION (NOTE CIL ITEMS ON 5-25)	5-25
PWRUP TABLE	5-25
AC1	5-26
MNA (CIL).....	5-27
AC2	5-30
MNB (CIL).....	5-31
AC3	5-34
MNC (CIL).....	5-35
CNTL AB.....	5-38
BC	5-39
CA	5-41
ESS 1BC (CIL)	5-42
2CA (CIL)	5-43
3AB (CIL).....	5-44

CONTENTS (Cont)

PAGE

GNC

GPS TROUBLESHOOTING 6-2

OMS

OMS SCHEMATIC 7-1
SECURE 7-2
TK P (FU and OX) HIGH 7-2
XFEED: R OMS to L OMS 7-2
L OMS to R OMS 7-2
XFEED RETURN: OMS 7-3
OMS N2 TK P LOW 7-3
REG P LOW 7-3
HIGH 7-3
TK P (FU or OX) LOW 7-4
He TK P LOW 7-6
LEAKING OMS PRPLT/He BURN 7-7
 Δ VX vs ORB ALT GRAPH 7-9
LEAKING OMS He Δ V TABLE 7-10

RCS

RCS SCHEMATIC 8-1
SECURE 8-2
I'CNCT: L OMS to RCS (CIL) 8-3
R OMS to RCS (CIL) 8-3
I'CNCT TK SWITCH: From L to R OMS FEED 8-4
From R to L OMS FEED 8-4
RETURN (OPS 2,3) 8-4
XFEED: R RCS to L RCS 8-5
L RCS to R RCS 8-5
XFEED RETURN: RCS 8-5
RCS RM LOSS 8-6
RM DLMA MANF 8-6
RCS TK P LOW (FU or OX) 8-7
HIGH (FU or OX) 8-7
JET FAIL (ON) 8-7
(LEAK) 8-7
(OFF) 8-7
LEAK ISOL 8-8

MPS

MPS C/W 9-2

APU/HYD

APU/
HYD

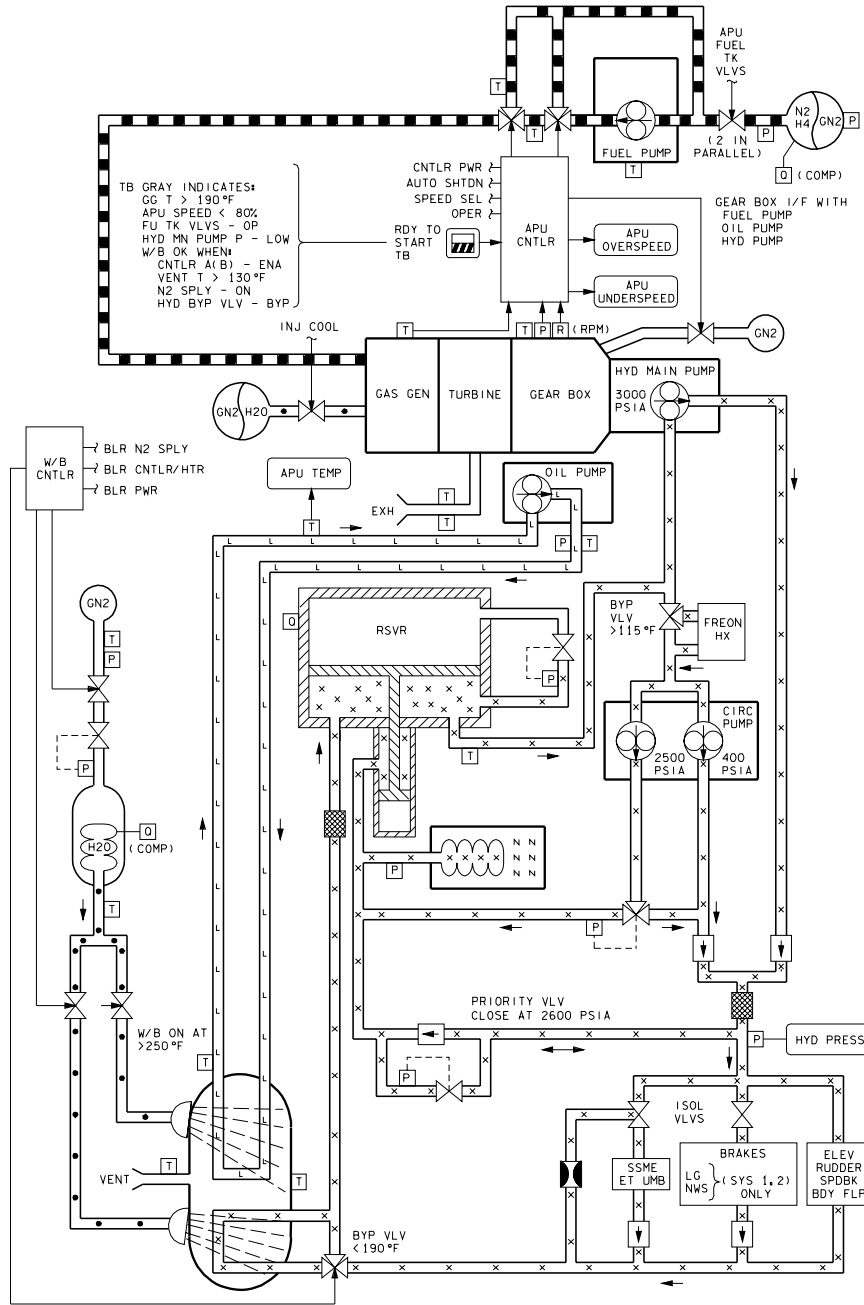

DATE 07/22/05
480330101, SCH: 2

APU/
HYD

HYD ACCUM (RSVR) P LOW

(SM2 HYD ACCUM P, ACUM P < 1930)

(S86 RSVR/ACC P, RSVR P < 28 or ACCUM P < 1930)

SM 87 HYD THERMAL

SM 86 APU/HYD

CAUTION

Hyd MN Pump may be damaged if
APU started with low HYD RSVR P

R2

1. (Aff) HYD CIRC PUMP – ON
2. √MCC

If no comm, go to MAL, APU/HYD, 1.2a, RSVR P ↓,
ACCUM P ↓ [1]

HYD CIRC PUMP PRESS LOW

(S87 CIRC PMP P, PRESS < 100)

SM 87 HYD THERMAL

CAUTION

HYD CIRC PUMP – OFF within 60 sec
to avoid damage

R2

1. HYD CIRC PUMP – OFF
2. √MCC

If no comm, go to MAL, APU/HYD, 1.3a,
HYD CIRC PUMP P ↓ [1]

APU FUEL SUPPLY T

(S86 FU TK VLV)
 (S88 APU TANK T)
 (S88 APU FU LN)

SM 88 APU/ENVIRON THERM

SM 86 APU/HYD

- A12
1. (Aff) APU HTR TK/FU LN/H2O SYS A – OFF
 B – OFF
 2. √MCC
 If no comm and 'S88 APU TANK T' or 'APU FU LN' msg, go to MAL, APU/HYD, 1.1b [2]
 If no comm and 'S86 FU TK VLV' msg, go to MAL, APU/HYD, 1.1c [1]

APU FUEL PUMP T

(S88 APU FU PMP)

SM 88 APU/ENVIRON THERM

- CRT
- A12
- If APU FUEL T PUMP OUT or BY P LN ↓:
1. (Aff) APU HTR GAS GEN/FU PUMP – A AUTO(B AUTO) >>
 2. (Aff) APU HTR GAS GEN/FU PUMP – OFF

NOTE

Expect 'S86 GG/FU PMP'
 and 'S86 GBX P FDA' msgs

3. √MCC
 If no comm, go to MAL, APU/HYD, 1.1b [2]

APU WATER T

(S88 APU H2O T)

SM 88 APU/ENVIRON THERM

- A12
- If H2O INJ LN 1 or 2 ↓↑:
1. APU HTR TK/FU LN/H2O SYS 1 A(B) – OFF
 B(A) – ON
 2. √MCC
- If H2O INJ LN 3 ↓↑:
3. APU HTR TK/FU LN/H2O SYS 3 A(B) – OFF
 B(A) – ON
 4. √MCC



This Page Intentionally Blank



COMMUNICATIONS

PROBLEM	PWRUP	
	LOW LEVEL (Group B)	MSN EXT (Group C)
COMM LOSS	N/A	PL 1

BCE BYP KU
(KU 8=M)**SM 201 ANTENNA**

1. ITEM 8 ENTER
- If msg repeats:
2. If AOS: √MCC for comm config
 3. If no comm: Go to COMM LOST, steps 6,7 for TDRS mode

ICOM LOST

Try following until ICOM AUDIO regained:

1. (Aff) AUD CNTL sel – sel alt
2. AUD CTR – 2
3. Plug into another ATU
4. Try another HDST/CCU
5. √MCC

S76 COMM PA 2(1) TEMP
(TEMP > 230)

SM 76 COMMUNICATIONS

1. Perform COMM LOST, steps 6,7 for TDRS mode, then:
 2. √Comm with MCC
- If no comm:
3. Go to COMM LOST

S76 PA 2(1) OUTPUT LOW
(PWR OUT < 60)

SM 76 COMMUNICATIONS

1. Perform COMM LOST, steps 6,7 for TDRS mode, then:
 2. √Comm with MCC
- If no comm:
3. Go to COMM LOST

S76 NSP 2(1) BITE
(BITE = 'FAIL')

SM 76 COMMUNICATIONS

1. Perform COMM LOST, steps 6,7 for TDRS mode, then:
 2. √Comm with MCC
- If no comm:
3. Go to COMM LOST

S76 COMSEC 2(1) BITE
(BITE = 'FAIL')

SM 76 COMMUNICATIONS

1. Perform COMM LOST, steps 6,7 for TDRS mode, then:
 2. √Comm with MCC
- If no comm:
3. Perform COMM LOST, step 9, then:
 4. √Comm with MCC
- If no comm:
5. Go to COMM LOST

COMM LOST (mult pnls)

SM 76 COMMUNICATIONS
SM ANTENNA

NOTE

Perform comm checks with MCC after each step

1. AUD CTR – 2(1)
- If all ICOM and A/G failed (check three ATUs):
- R14:A,F
2. √cb ACCU (two) – cl
 3. Go to step 10
 4. **SM 62 PCMMU/PL COMM**
If PI XMIT PWR not blank:
A1L Deactivate PI:
√S-BD PL CNTL – CMD
PWR SEL – PSP
CNTL – PNL,CMD
Wait 2 min for TDRS acquisition
 5. If F9 meter < 300, wait for next TDRS in view

NOTE

When selecting between DC Amps and Signal Strength posns, expect fluctuations which will dampen out within 1 min

- If no joy on next TDRS or comm required sooner:
- A1L
6. Verify configured for TDRS mode:
√NSP UPLK DATA – S-BD
√S-BD PM MODE sel – TDRS
√NSP DATA RATE (two) – HI
√NSP CODING (two) – ON
- C3
7. S-BD PM CNTL – PNL

NOTE

XMIT may be delayed 140 sec for PA warmup.
Receive not affected

8. Sel best ant, F9 meter > 300. If no joy, return to GPC
9. Bypass encrypt (2 min reqd for MCC reconfig):
A1L NSP ENCRYPTION MODE – SEL
SEL – BYP

Cont next page

10. Confirm U/L CMD capability:
 - Cue MCC with: ITEM 88 +8 8 8 8 8
 - Check flashing U/L on GNC display
 - Ack with: ITEM 99 +9 9 9 9 9
 - Check abort light cycling ON/OFF (MCC ack)
 - Check no flashing U/L

If U/L CMD confirmed:

11. Go to MAL, COMM SSR-1, LOSS OF ALL VOICE
COMM >>

If no comm and no U/L CMD:

12. Go to MAL, COMM, 2.3a, NO S-BD COMM: TDRS

UHF COMM LOST (mult pnls)

NOTE

Perform comm checks with MCC after each step

- O6
1. √UHF SPLX/EVA PWR AMPL – ON
 2. AUD CTR – 2(1)
- Reconfig UHF sys:
3. UHF SPLX SQUELCH – OFF
 4. UHF SPLX/EVA XMIT FREQ – 296.8/417.1
Call site stating “on 296.8”, wait 30 sec for site reconfig
 5. Roll vehicle HEADS UP to point UHF antenna at ground
 6. UHF SPLX/EVA PWR AMPL – OFF (LO PWR XMIT)
 7. UHF MODE sel – G T/R
Call site stating “on 243.0”, wait 30 sec for site reconfig



DPS

DATA PROCESSING SYSTEM



ALL IDPs ASSIGNED TO FAILED GPC

CAUTION

If GPC/CRT key used to assign IDP1(2,3) to BFS, deassign to avoid dual commanders

1. If no active GNC GPC: Go to GNC RECOVERY VIA G2FD >>
 2. (Failed) GPC PWR – OFF
 3. IDP/CRT1,2,3 MAJ FUNC – PL
 4. √(FD) GPC PWR – ON
MODE – STBY,RUN (tb-RUN)
 5. IDP/CRT1,2,3 MAJ FUNC – as desired
- If FD GPC not needed to recover lost major function:
6. (FD) GPC MODE – STBY (tb-bp),HALT
– STBY (tb-RUN)
– HALT (tb-bp)
- If GNC GPC failed: Go to PASS GNC GPC (1st FAIL) >>
If SM GPC failed: Go to PASS SM GPC FAIL

DPS

DUAL DPS DISPLAY COMMANDERS

- If aff IDP assigned to BFS via BFC sw:
1. BFC CRT DISP – OFF, then go to step 3
 2. BFC CRT DISP – ON
SEL – aff IDP
- If reqd to clean up display:
3. (Aff) IDP/CRT – OFF,ON

BFS ENGAGE

1. RGAs (four) – ON
2. √(BFS) GPC PWR – ON
MODE – STBY (tb-RUN)
OUTPUT – B/U
3. (SM) GPC OUTPUT – NORM
4. BFC CRT DISP – ON
5. √cb DDU L,R (four) – cl
6. L(R) FLT CNTLR PWR – ON
7. √Pri RJDs (sixteen) – ON
8. L(R) RHC BFS engage pb – push

NOTE

BFS will take PL buses from SM GPC

9. (BFS) GNC, OPS 301 PRO
10. OI PCMMU FORMAT – FXD
11. If no comm at AOS: sel best S-BD PM ANT
12. Go to MAL, DPS, GPC FRP-4, PASS RECOVERY AFTER BFS ENGAGE (ASCENT/ORBIT/ENTRY)

SUMWORD ICC 1(2,3,4)

If CS = 2, when time permits:

1. Go to MAL, DPS SSR-2, GPC S/W INITIATED MEM DUMP >>

If only one GPC annun:

Consider annunciating GPC failed:

2. Go to PASS SM(GNC) GPC FAIL >>

If annun against SM GPC (prior to adding the GPC to redundant set):

3. Go to PASS SM GPC FAIL >>

If annun against single GNC GPC:

4. Go to PASS GNC GPC (1st FAIL)

**ALL IDPs/FAILED GPC
DUAL DPS DISP CDRs
BFS ENGAGE**

3-3

OPCL/ALL/GEN M

SUMWORD ICC

BCE STRG X (no 'MDM OUTPUT' msg)

If IMU:

1. GNC 21 IMU ALIGN
IMU – desel
2. √OPER/STBY mode
3. If OPER: Go to step 6

NOTE

If > 3 min since 'IMU' msg occurred (poss undetect IMU cage), upon IMU recovery, check att ANG prior to 'resel if IMU'

4. If STBY: Go to MAL, DPS, 5.3b, BCE STRG X 1 >>

If MTU:

If mult 'STRG MTU' msgs:

5. Go to MAL, DPS, 5.2d, TIME MTU 11 >>
6. GNC I/O RESET

If recovered:

7. Resel if IMU >>

If NSP and msg repeats:

8. If AOS: √MCC

If LOS/no comm:

9. Go to COMM LOST, step 6 (COMM), 2-3 >>
10. GNC 1 DPS UTILITY

Aff String – port mode

If recovered:

11. Resel if IMU >>
12. Cycle MDM – OFF,ON (FF: may cage IMU)

NOTE

Cycle FF if 'A' or 'B' msg; cycle FA if 'C' or 'D'

13. GNC I/O RESET

Cont next page

If recovered:

14. Resel if IMU >>
15. Orig ports – resel
16. If IMU or GPS: √MCC >>
17. If any other:
Go to MAL, DPS, 5.3b, BCE STRG X [15]

PL1(2) MDM I/O ERROR; PL1(2) MDM OUTPUT

If mult simo 'I/O ERR' or 'MDM OUTPUT' msgs on PL1 and PL2 (GPC prob):

1. Go to PASS SM GPC FAIL >>
 2. SM I/O RESET; if recovered:
If PSP reqd:
 3. SM 62 PCMMU/PL COMM
PSP I/O RESET PSP 1(2) – ITEM 6(7) EXEC (*)
 4. If reqd, go to PL/DPS RECONFIG, Recovery [PL SYS (PL OPS)(SODF: ASSY OPS)] >>
 5. If reqd, perform PL/DPS RECONFIG, Secure [PL SYS(PL OPS) (SODF: ASSY OPS)], then:
If MCC GO for pwr cycle:
 6. (Aff) MDM PL – OFF,ON
 7. SM I/O RESET; if recovered:
If PSP reqd:
 8. SM 62 PCMMU/PL COMM
PSP I/O RESET PSP 1(2) – ITEM 6(7) EXEC (*)
 9. If reqd, go to PL/DPS RECONFIG, Recovery [PL SYS (PL OPS)(SODF: ASSY OPS)] >>
- If msg repeats:
10. If PL1 msg and no comm: Go to COMM LOST, steps 5,6,7,8 for TDRS mode (COMM), 2-3
 11. If PL2 msg and no comm: Sel best S-BD PM ANT
 12. Go to MAL, DPS, 5.3c, I/O ERROR/MDM OUTPUT PL 1(2) [1]

OPCL/ALL/GEN M,7

BCE STRG X

3-5

**PL1(2) MDM
I/O ERROR/OUTPUT**

FF(FA) MDM OUTPUT

FAULT

1. GNC I/O RESET
2. If no 'MDM OUTPUT': Re-annun >>
If single 'MDM OUTPUT' msg:
 3. **GNC 1 DPS UTILITY**
Port mode
 4. If no 'MDM OUTPUT': Annun >>

NOTE

If dual GNC OPS and 'MDM OUTPUT' msg(s)
annun by:

Redundant set – failed GPC is commanding
the aff strings

Single GNC GPC – failed GPC is annun fault
msg(s)

If not recovered:

5. Go to PASS GNC GPC (1st FAIL)

FF(FA) MDM I/O ERROR

- ◆ 1. GNC I/O RESET; if recovered >>
If simo 'I/O ERR' msgs for mult MDMs (possible GPC prob):
 2. √MCC/restring as reqd >>
 3. If FF: Check ADI (aff String)
 4. If ADI 'OFF' flag (GPC prob): Go to step 16
 5. **GNC 1 DPS UTILITY**
Aff String – port mode; if recovered >>
If alt msg on aff string (GPC prob):
 6. Go to step 16
- If MCC GO for pwr cycle:
 7. If FF:
GNC 21 IMU ALIGN
Aff IMU – desel
 8. (Aff) MDM – OFF, ON (FF: may cage IMU)
 9. GNC I/O RESET
 10. If recovered: resel IMU if desel >>
 11. Resel orig ports
 12. If recovered: resel IMU if desel >>
 13. If not: Go to MAL, **DPS**, 5.3a, I/O ERROR FF(FA) **17** >>
- If MCC NO-GO for pwr cycle:
 14. If FF:
GNC 21 IMU ALIGN
Aff IMU – desel >>
 15. If FA1 or FA2, then:
R OMS TK ISOL A – CL (tb-CL) >>
16. Sel desired FF/FA MDM:
 17. **GNC 1 DPS UTILITY**
Port mode as reqd
- If FF MDM not chosen:
 18. **GNC 21 IMU ALIGN**
Aff IMU – desel
19. When time permits restring (with possible F-T-S):
Go to MAL, **DPS**, 5.3a, I/O ERROR FF(FA) **1**

OPCL/ALL/GEN M,8

FF(FA) MDM OUTPUT

3-7

FF(FA) MDM I/O ERROR

PASS GNC GPC (1st FAIL)

NOTE

If Group B(C) LOW LEVEL (MSN EXT) pwrdn config,
MMU 2 – ON

NOTE

No keyboard entries or sw throws 10 sec:
Before and after moding PASS GPCs to RUN
Before OPS transition or set expansion/contraction
requests until new OPS base page is displayed

If no active GNC GPC and G2FD GPC avail:

| 1. Go to GNC RECOVERY VIA G2FD >>

If no active GNC GPC and no FD GPC avail:

| 2. Go to BFS ENGAGE >>

If failure is CS split and GPC config is one GNC and one SM:

| 3. Go to MAL, DPS, 5.1a, CS SPLIT [1] >>

If Dual G2 and RS split (CS intact) but both GPCs appear functional

| (check DPS and ADI displays, MODE tb):

| 4. Retain GPC with two IMUs

If Triple G2 and RS split but GPCs appear functional

| (check DPS and ADI displays, MODE tb):

| 5. Retain GPC with two strings

6. (Aff) GPC PWR – OFF

If FF1 PWR cycled:

7. GNC 21 IMU ALIGN
IMU 1 (caged) – desel

8. Reassign failed GPC IDPs: GPC/CRT as reqd

9. GNC 0 GPC MEMORY

Check downlist to active GNC GPC:
DOWNLIST GPC – ITEM 44 +X EXEC

If redundant GNC GPCs reqd and G2FD avail:

| 10. √(G2FD) GPC MODE – HALT
| √OUTPUT – NORM
| √PWR – ON
| MODE – STBY (tb-RUN),RUN

| 11. IDP/CRTX MAJ FUNC – PL

| 12. GPC/CRT – (G2FD) GPC/X EXEC

If GNC OPS 202:

| 13. GNC, OPS 201 PRO

~

Cont next page

- If RNDZ NAV Ena:
14. DAP: LVLH
 15. GNC UNIV PTG
CNCL – ITEM 21 EXEC (no *)
 16. √Tgt set, assign FC strings, CRTs, and MMUs in current MC
(check PL1/2 and L1,2 deassigned)
 17. GNC, OPS 201 PRO
- If RNDZ NAV reqd:
18. Perform RNDZ NAV RECOVERY (RNDZ, CONTINGENCY OPS)
 19. GNC 22 S TRK/COAS CNTL
S TRK -Y,-Z: STAR TRK – ITEM 3,4 EXEC (*)
 20. GNC 21 IMU ALIGN; RESUME
- If {redundant GNC GPCs not reqd or G2FD not avail} and MCC GO for restring:
21. Assign FC strings, CRTs, and MMUs in current MC
(check PL1/2 and L1,2 deassigned)
 22. GNC, OPS XXX PRO
 23. When time permits: Go to MAL, DPS, GPC FRP-1, SINGLE GPC FAIL

PASS SM GPC FAIL

NOTE

No keyboard entries or sw throws 10 sec:
Before and after moding PASS GPCs to RUN
Before OPS transition or set expansion/contraction requests until new OPS base page is displayed

NOTE

Ku-Band sys may be reqd to be taken to STBY to prevent exceeding radiation constraints of the PL/EVA crewmember

If AOS:

1. √MCC for comm config and radiation constraints

If no comm:

A1U

2. KU BD PWR – STBY
CNTL – PNL,CMD
 3. Perform COMM LOST, steps 6,7,8 for TDRS mode (COMM), 2-3
 4. √MMU 2 PWR – ON
- If failure is CS split and GPC config is one GNC and one SM:
5. Go to MAL, DPS, 5.1a, CS SPLIT 1 >>

Cont next page

OPCL/ALL/GEN M,6

PASS GNC GPC (1st)

3-9

PASS SM GPC FAIL

6. If reqd, perform PL/DPS RECONFIG, Secure [PL SYS(PL OPS) (SODF: ASSY OPS)], then:
 7. (SM) GPC PWR – OFF
 8. MDM PL1,2 PWR (two) – OFF, ON
 9. GNC 1 DPS UTILITY
 UL CNTL ENA – ITEM 36 EXEC (*)
 √CKPT RETRV ENA – ITEM 12 EXEC (*)
- If G2FD GPC avail:
10. √(G2FD) GPC MODE – HALT
 √PWR – ON
 MODE – STBY (tb-RUN), RUN
- If G2FD GPC not avail and triple G2:
11. Assign two GNC GPCs strings, CRTs, and MMUs in current MC (verify PL1/2 and LB1 deassigned). Do not change target set
 12. GNC, OPS XXX PRO
 13. (Tgt) GPC MODE – STBY (tb-bp)
 – RUN (tb-RUN)
 14. (Tgt) GPC OUTPUT – TERM
 15. IDP/CRTX MAJ FUNC – SM
 16. GPC/CRT tgt GPC/X EXEC
 17. SM 0 GPC MEMORY
 Assign tgt GPC CRTs, MMUs, PL1/2 and LB1 in MC 4(5)
 18. SM, OPS 201(401) PRO (Tgt GPC IDP)
 19. SM 1 DPS UTILITY
 UL CNTL AUTO – ITEM 35 EXEC (*)
 CKPT RETRV ENA – ITEM 12 EXEC (*)
 20. Perform LOAD PCMMU FORMAT (ORB OPS FS, COMM/INST), then:
- If PSP reqd:
21. SM 62 PCMMU/PL COMM
 PSP I/O RESET PSP 1(2) – ITEM 6(7) EXEC (*)
- If PLBD OPS:
22. PL BAY DR SYS (two) – ENA
- If RMS PWR – PRI (MCIU pwrd):
23. SM 94 PDRS CONTROL
 (MA, C/W GPC DATA It on)
 I/O ON – ITEM 5 EXEC (*) (C/W GPC DATA It off)
 Update as needed:
 WR range, PL ID, PL INIT ID, EE ID, SPEC 95 overrides
- A8U
24. If reqd, perform PL/DPS RECONFIG, Recovery [PL SYS(PL OPS) (SODF: ASSY OPS)], then:
 25. When time permits: Go to MAL, DPS, GPC FRP-1, SINGLE GPC FAIL

PASS GPC BITE 1(2,3,4)

If SM GPC annun BITE:

1. Go to PASS SM GPC FAIL >>

If single G2 and GNC GPC annun BITE:

2. Go to GNC RECOVERY VIA G2FD >>

If $RS \geq 2$ and only one GNC GPC annun BITE (hardware):

3. Go to PASS GNC GPC (1st FAIL) >>

If $RS \geq 2$ and all GNC GPCs annun BITE (software):

If cyclic logging of BITE:

If FD GPC avail:

4. Go to GNC RECOVERY VIA G2FD >>

If FD GPC not avail:

5. Check MCC for GO to perform BFS ENGAGE >>

If non-cyclic logging of BITE:

6. When time permits: Go to MAL, DPS SSR-2, GPC S/W INITIATED MEM DUMP

OPCL/ALL/GEN M

GNC RECOVERY VIA G2FD

NOTE

No keyboard entries or sw throws 10 sec:
Before and after moding PASS GPCs to RUN
Before OPS transition or set expansion/contraction requests until new OPS base page is displayed

If OPS transition failure:

1. Go to MAL, DPS, 5.2a, I/O ERROR MMU 1(2) or MAL, DPS, 5.2b, OFF/BUSY MMU 1(2), as reqd >>
2. (Failed) (GNC) GPC(s) PWR – OFF
3. Secure SM:
A1U KU BD PWR – STBY
CNTL – PNL,CMD
C3 Sel best ant, F9 meter > 300
SM 62 PCMMU/PL COMM
FORMAT FXD – ITEM 1 EXEC (*)
Perform PL/DPS RECONFIG, Secure [PL SYS(PL OPS) (SODF: ASSY OPS)], time permitting, then:
4. (SM) GPC MODE – STBY (tb-bp) (expect Big X/Poll Fails)
5. Activate Freeze Dry GPC:
G2FD: √GPC MODE – HALT
√OUTPUT – NORM
√PWR – ON
MODE – STBY (tb-RUN),RUN
Verify G2FD grabs three FWD IDP/CRTs (reassign IDP4 as reqd)
6. If G2FD activation fails, go to step 20
7. MC 2 NBAT Setup for Target GPC (Activated G2FD):
GNC 0 GPC MEMORY

NOTE

If currently active IMU was in STBY or IMU currently in STBY was active during time of G2 freeze-dry, do not assign associated string

Assign all FC strings (except as noted above), CRTs 1,2,3, and MMUs to just activated target GPC (verify PL1/2 and L1,2 deassigned)

8. Config for GNC OPS Transition:
Pri RJD DRIVER (eight) – OFF
√RJD MANF L5/F5/R5 DRIVER – ON

Cont next page

NOTE

If G2FD last freeze-dried while RS in G1(G3), holding DAP: FREE pb during OPS transition avoids PRCS false jet fail-off msgs (DAP defaults to A1/AUTO/PRI)

If reqd, DAP: FREE pb – push and hold during OPS transition

GNC, OPS 201 PRO

√DAP: FREE

9. Configure IMU and restrng:

GNC 21 IMU ALIGN

Desel aff IMU from step 7

Configure aff IMU to STBY(OPER) as reqd to match GROUP B PWRDN(PWRUP) (no * until restrng)

GNC 0 GPC MEMORY

Assign remaining FC string to GNC GPC

GNC, OPS 201 PRO

√MCC for resel of aff IMU

10. Re-establish GNC Operational Config:

Pri RJD DRIVER (eight) – as reqd

GNC 20 DAP CONFIG

Load desired DAP A,B

(see FLIGHT PLAN, ORB OPS FS)

GNC 22 S TRK/COAS CNTL

S TRK -Y,-Z: STAR TRK – ITEM 3,4 EXEC (*)

GNC 21 IMU ALIGN

RESUME

GNC 23 RCS

JET RESET – ITEM 45 EXEC

If L(R) OMS/RCS I'CNCT:

L(R) OMS – ITEM 5(6) EXEC

11. If Orbiter attitude control reqd:

DAP: INRTL/VERN(ALT)

12. Restart SM:

(SM) GPC MODE – RUN (tb-RUN), pause 10 sec

IDP/CRTX: MAJ FUNC – SM

GPC/CRT – SM GPC/X EXEC (not reqd if

performing step 21)

SM 1 DPS UTILITY

√CKPT RETRV ENA – ITEM 12 EXEC (no *)

SM, OPS 201 PRO, pause 10 sec

Cont next page

13. Re-establish SM Operational Config:

NOTE

TFLs reloaded to avoid G2FD GPC utilizing stale downlist-rate status when PGM format is resel

SM 62 PCMMU/PL COMM

Perform LOAD PCMMU FORMAT (ORB OPS FS, COMM/INST)

SM 1 DPS UTILITY

CKPT RETRV ENA – ITEM 12 EXEC (*)

UL CNTL ENA – ITEM 36 EXEC

If RMS PWR – PRI (re-establish MCIU I/O):

14. SM 94 PDRS CONTROL

(MA, GPC DATA It on)

I/O ON – ITEM 5 EXEC (*) (GPC DATA It off)

SAFING – CANCEL (tb-bp if arm desel)

A8U

15. If reqd, perform PL/DPS RECONFIG, Recovery [PL SYS(PL OPS) (SODF: ASSY OPS)], then:

16. Wait for Orbiter SV Uplink:

NOTE

Auto antenna sel and any auto attitude mnvrs may be incorrect until a valid Orbiter SV is uplinked

A1U

17. S-BD ANT – GPC

KU BD PWR – ON

SM 1 DPS UTILITY

UL CNTL AUTO – ITEM 35 EXEC

18. Re-establish Track Attitude, as reqd:

UNIV PTG

Load desired att (see FLIGHT PLAN)

Init TRK(MNVR) – ITEM 19(18) EXEC

DAP: AUTO

19. Go to MAL, DPS GPC FRP-1, SINGLE GPC FAIL >>

If G2FD activation fails:

20. (G2FD) GPC PWR – OFF

21. Perform step 12 for temp IDP and SM interface

If second G2FD exists: √MCC for GO to step 4

If a G3FD exists: √MCC for proc

If no FD: √MCC for GO to perform BFS ENGAGE

EQUIPMENT COOLING MATRIX

AIR-COOLED		WATER-COOLED	
FORCED	FREE-FLOW		
AV BAY 1		AV BAY 1	
GPC 1,4 ① MLS RF & DECODER 1	BFC 1 (ENGAGE) CICU AA 1,4 TACAN 1 PROXIMITY SW	AC INV 1A,1B,1C LCA(FWD) 1 PCA(FWD) 1 MCA(FWD) 1	MMU 1 RJDF 1A,1B P/L RECORDER
MIDDECK PL ②	INVERTER DIST & CNTL	MDM PL1,OF1, FF1,LF1	PCMMU 1 PDI
AV BAY FAN A,B	BRK CNTL 1 SMOKE DET A,B CURRENT SNSR ADTA 1,3	DSC OF1 ACCU 1,2 PWR SUPPLY/BATT CHARGER	RADAR ALT 1
AV BAY 2		AV BAY 2	
GPC 2,5 ① MLS RF & DECODER 2,3	BFC 2,3 (ENGAGE) AA 2,3 TACAN 2 PROXIMITY SW	AC INV 2A,2B,2C LCA(FWD) 2 PCA(FWD) 2 MCA(FWD) 2	MMU 2 RJDF 2A,2B PCMMU 2 S-BD PL RF COAX SW
MIDDECK PL ②	INVERTER DIST & CNTL	MDM PL2,OF2, FF2,FF4	OPS RECORDER 1,2
AV BAY FAN A,B	BRK CNTL 2 SMOKE DET A,B CURRENT SNSRS ADTA 2,4	DSC OF2 PL INTEROG 1,2	RADAR ALT 2 PSP 1,2
AV BAY 3A		AV BAY 3A	
GPC 3 ① AV BAY FAN A,B	S-BAND EQUIP: FM MLTPLXR QUAD ANT SW ASSEMBLY	AC INV 3A,3B,3C LCA(FWD) 3 PCA(FWD) 3 MCA(FWD) 3	EBIA (BYPASS SWITCH) COMSEC 1,2,3 UHF EVA XCVR KU-BND EA 1,2
C/W LIMIT MODULE SSOR ②	FM SIG PRCSR SW BEAM ANT CNTL ASSY FM RF SWITCH	MDM FF3,OF3 DSC OF3 NSP 1,2	GCIL
MIDDECK PL ②	TACAN 3 CURRENT SNSR INVERTER DIST & CNTL SMOKE DET A,B	S-BAND PA 1,2; PRE-AMP 1,2; XPNDR 1,2; FM XMTR 1,2	
		AV BAY 3B	
		MTU KU-BAND SIGNAL PROCESSOR HUD ELECT 1,2 GPS 2	

ECLS

05/15/09

- ① GPC INSTALLATION REFERS TO CPU/IOP/MEMORY UNIT.
- ② IF FLOWN.

Cont next page

OV103,104

A4-1

OPCL/3,4/GEN M,10

EQUIPMENT COOLING MATRIX (Continued)

AIR-COOLED		WATER-COOLED
FORCED	FREE-FLOW	
CABIN		ECLSS EQUIPMENT BAY
MDUs (eleven) CAB FAN A,B IMU 1,2,3 IMU FANS ③ TV MONITORS RCU VSU MCIU IDP 1,2,3,4 MADS RCDR MS & PS STATION	MTRS/LTS/IND C/W ANNUN SPKR UNITS ATUs CAMCORDER COLOR PRINTER PGSC VTR CSA CAB TEMP CNTLR A,B WMS HUMIDITY SEP SMOKE DET: L,R FLT DECK CABIN ADC 1A,1B,2A,2B MCM HUD PDU L,R DDU 1,2,3	WATER PUMP 1A,1B SEC
		FLIGHT DECK MDM OF4

ECLS

FREON-COOLED			
AFT COLDPLATES			MIDBODY
BAY 4	BAY 5	BAY 6	
LCA-1 PCA-1,4 MCA-1 MDM FA1 OA1 APU CNTLR 1 ATVC ELECT 1 EIU 1 MPS ULL P SC1 ASA 1 RGA 1 RJDA 1 MEC 1 DSC OA1 DBIA 1	LCA-2 PCA-2,5 MCA-2 MDM FA2 OA2 APU CNTLR 2 ATVC ELECT 2 EIU 2 MPS ULL P SC2 ASA 2 RGA 2 MEC 2 DSC OA2 DBIA 2 PT SNSR	LCA-3 PCA-3,6 MCA-3 MDM FA3,4 OA3 APU CNTLR 3 ATVC ELECT 3,4 EIU 3 MPS ULL P SC3 ASA 3,4 RGA 3,4 RJDA 2 MPS DP SC DSC OA3	PCA(MID) 1,2,3 MCA(MID) 1,2,3,4 MDM PM1 RMA 1,2 FEA 1,2 SGSC H2/O2 CRYO HTR 1A,1B,2A,2B FCL 1 PMP A,B 2 PMP A,B FUEL CELLS 1,2,3 MN DA 1,2,3 MIDBODY PIC CNTLR DSC OM1,OM2,OM3

10/13/04

- ③ IMU FANS ARE LOCATED IN AVIONICS BAY 1 BUT CIRCULATE CABIN AIR RATHER THAN FLOW FROM AVIONICS BAY 1 THROUGH THE IMUs FOR COOLING.

OV103,104

A4-2

OPCL/ALL/GEN M

EQUIPMENT COOLING MATRIX

AIR-COOLED		WATER-COOLED	
FORCED	FREE-FLOW		
AV BAY 1		AV BAY 1	
GPC 1,4 ① MLS RF & DECODER 1	BFC 1 (ENGAGE) CICU AA 1,4 PROXIMITY SW GPS 1 INVERTER DIST & CNTL	AC INV 1A,1B,1C LCA(FWD) 1 PCA(FWD) 1 MCA(FWD) 1	MMU 1 RJDF 1A,1B P/L RECORDER
MIDDECK PL ② AV BAY FAN A,B	BRK CNTL 1 SMOKE DET A,B CURRENT SNSR ADTA 1,3	MDM PL1,OF1, FF1,LF1 DSC OF1 ACCU 1,2 PWR SUPPLY/BATT CHARGER	PCMMU 1 PDI RADAR ALT 1
AV BAY 2		AV BAY 2	
GPC 2,5 ① MLS RF & DECODER 2,3	BFC 2,3 (ENGAGE) AA 2,3 PROXIMITY SW INVERTER DIST & CNTL	AC INV 2A,2B,2C LCA(FWD) 2 PCA(FWD) 2 MCA(FWD) 2	MMU 2 RJDF 2A,2B PCMMU 2 S-BD PL RF COAX SW
MIDDECK PL ② AV BAY FAN A,B	BRK CNTL 2 SMOKE DET A,B CURRENT SNSRS ADTA 2,4	MDM PL2,OF2, FF2,FF4 DSC OF2 PL INTEROG 1,2	OPS RECORDER 1,2 RADAR ALT 2 PSP 1,2
AV BAY 3A		AV BAY 3A	
GPC 3 ① AV BAY FAN A,B	S-BAND EQUIP: FM MLTPLXR QUAD ANT SW ASSEMBLY FM SIG PRCSR SW BEAM ANT CNTL ASSY FM RF SWITCH	AC INV 3A,3B,3C LCA(FWD) 3 PCA(FWD) 3 MCA(FWD) 3	EBIA (BYPASS SWITCH) COMSEC 1,2,3 UHF EVA XCVR KU-BND EA 1,2
C/W LIMIT MODULE SSOR ② MIDDECK PL ②	GPS 3 CURRENT SNSR INVERTER DIST & CNTL SMOKE DET A,B	MDM FF3,OF3 DSC OF3 NSP 1,2 S-BAND PA 1,2; PRE-AMP 1,2; XPNDR 1,2; FM XMTR 1,2	GCIL
		AV BAY 3B	
		MTU KU-BAND SIGNAL PROCESSOR HUD ELECT 1,2 GPS 2	

05/15/09

- ① GPC INSTALLATION REFERS TO CPU/IOP/MEMORY UNIT.
- ② IF FLOWN.

ECLS

Cont next page

B4-1

OV105

OPCL/5/GEN M,10

EQUIPMENT COOLING MATRIX (Continued)

AIR-COOLED		WATER-COOLED
FORCED	FREE-FLOW	
CABIN		ECLSS EQUIPMENT BAY
MDUs (eleven) CAB FAN A,B IMU 1,2,3 IMU FANS ③ TV MONITORS RCU VSU MCIU IDP 1,2,3,4 MADS RCDR MS & PS STATION	MTRS/LTS/IND C/W ANNUN SPKR UNITS ATUs CAMCORDER COLOR PRINTER PGSC VTR CSA CAB TEMP CNTLR A,B WMS HUMIDITY SEP SMOKE DET: L,R FLT DECK CABIN ADC 1A,1B,2A,2B MCM HUD PDU L,R DDU 1,2,3	WATER PUMP 1A,1B SEC
		FLIGHT DECK MDM OF4

ECLS

FREON-COOLED			
AFT COLDPLATES			MIDBODY
BAY 4	BAY 5	BAY 6	
LCA-1 PCA-1,4 MCA-1 MDM FA1 OA1 APU CNTLR 1 ATVC ELECT 1 EIU 1 MPS ULL P SC1 ASA 1 RGA 1 RJDA 1 MEC 1 DSC OA1 DBIA 1	LCA-2 PCA-2,5 MCA-2 MDM FA2 OA2 APU CNTLR 2 ATVC ELECT 2 EIU 2 MPS ULL P SC2 ASA 2 RGA 2 MEC 2 DSC OA2 DBIA 2 PT SNSR	LCA-3 PCA-3,6 MCA-3 MDM FA3,4 OA3 APU CNTLR 3 ATVC ELECT 3,4 EIU 3 MPS ULL P SC3 ASA 3,4 RGA 3,4 RJDA 2 MPS DP SC DSC OA3	PCA(MID) 1,2,3 MCA(MID) 1,2,3,4 MDM PM1 RMA 1,2 FEA 1,2 SGSC H2/O2 CRYO HTR 1A,1B,2A,2B FCL 1 PMP A,B 2 PMP A,B FUEL CELLS 1,2,3 MN DA 1,2,3 MIDBODY PIC CNTLR DSC OM1,OM2,OM3

10/13/04

- ③ IMU FANS ARE LOCATED IN AVIONICS BAY 1 BUT CIRCULATE CABIN AIR RATHER THAN FLOW FROM AVIONICS BAY 1 THROUGH THE IMUs FOR COOLING.

OV105

B4-2

OPCL/ALL/GEN M

O2(N2) FLOW HIGH/CAB P LOW/dP/dT

SM SYS SUMM 1

WARNING
If -dP/dT is 0.55 psi/min (OSH), loss of vehicle atmosphere imminent
When PPO2 < 2.2, emergency breathing apparatus reqd (dP/dT x 0.2 ~ PPO2 decay rate)
If, after alarm, O2(N2) flow > 1.0 lb/hr: Assume flow rate exceeds 5.0 lb/hr (OSH)

If docked to ISS and hatches open:

1. Perform JOINT EMERGENCY EGRESS (SODF: JOINT OPS, Cue Card) to isolate ISS, then:
 2. If dP/dT EQ positive or zero (ISS leak),
√MCC >>
- MO10W
3. 14.7 CAB REG INLET SYS 1, SYS 2 vlv (two) – CL
If orbiter dP/dT EQ positive or zero:
 4. Go to MAL, ECLS, 6.2a, O2(N2) FLOW ↑ **4**
>>

NOTE

If orbiter dP/dT EQ positive or zero after any leak isolation step, √MCC

LEAK ISOLATION

- L2 5. CAB RELIEF A – CL (tb-CL), pause,
B – CL (tb-CL)
6. √VENT ISOL – ctr (tb-bp)
√VENT – ctr (tb-bp)
- ML31C 7. √VAC VENT ISOL VLV BUS SEL – MNA
CNTL – CL (tb-CL)
- Side Hatch 8. NEG PRESS RLF vlv cover (two) – push firmly
WCS 9. Remove urinal hose from hose block
10. Check center hole (between hose block filters) in hose block for airflow
If airflow detected (EMU drain induced cabin leak):
 11. Using Gray Tape, block center hole in hose block (EMU drain)
 12. Go to MAL, ECLS, 6.2b, CABIN PRES ↑↓ **64** |
>>
13. Reinstall urinal hose
- Ext A/L 14. NEG PRESS RLF vlv cover (two) – push firmly

Cont next page

If SH HATCH open:

- 15. Perform SH CABIN LEAK ISOLATION (Cue Card)
- 16. Disconnect airlock flex duct from cab floor, stow
- 17. AIRLK FAN A(B) – OFF
- 18. Close INNER HATCH:
 - Position handle to preclosing posn per decal
 - Hatch – rotate about hinge and push
 - Handle – CCW to LATCH
 - Lock lever to LOCKED
 - Remove INNER HATCH Equal vlv cap (two)
 - Equal vlv (two) – OFF
- 19. Install diffuser cap on cab floor outlet (when time permits)

If dP/dT EQ positive or zero (A/L leak; possible loss of EVA capability and loss of access to ISS/SH):

- 20. CAB RELIEF (two) – ENA (tb-ENA)
 - If 14.7 psi ops:
 - 21. O2/N2 CNTLR VLV SYS 1(2) – AUTO
 - 22. 14.7 CAB REG INLET SYS 1(SYS 2) vlv – OP
 - √O2 REG INLET SYS 1(SYS 2) vlv – OP
- 23. VAC VENT ISOL VLV CNTL – OP (tb-OP)
- 24. √MCC for SH deactivation steps >>

CAUTION

ODS avionics require 8 psia or greater for cooling. √MCC regarding possible repress of ODS prior to ISS undocking

If dP/dT EQ still negative:

UNISOLATABLE ORBITER LEAK:
PREPARE FOR DEORBIT

Utilize SH(A/L) Atmosphere

CAUTION

Perform steps 25-28 before determining type of deorbit, to avoid volume-based nomograph errors

- 25. INNER HATCH Equal vlv (two) – EMER (vlvs remain in EMER for duration of flt)

Cont next page

- If Spacehab:
- TNL ADP
Inner Hatch
26. Open INNER HATCH per decal
 27. SH HATCH Equal vlv (two) – EMER
 28. Close INNER HATCH:
Position handle to preclosing posn per decal
Hatch – rotate about hinge and push
Handle – CCW to LATCH
Lock lever to LOCKED
- Deactivate Spacehab:
- SM 214 SHAB ACT/DEACT
29. FANS ARS OFF – ITEM 61 EXEC (*)
 30. Perform SPACEHAB EMERGENCY DEACT, steps 1-8,10 (Cue Card)

Determine Type of Deorbit

Determine latest poss TIG, Tmax, and avail landing sites using PGSC (preferred) or NOMOGRAPHS, 4-8

If docked to ISS and TIG > 1 hr 30 min and Orbiter Only Tmax does not support PLS, perform UTILIZE ISS ATMOSPHERE, (SODF: JOINT OPS, EMERGENCY RESPONSE) concurrently with remaining steps below

If TIG < 2 hr 40 min and not Orb 2,3 deorbit:

- | | | |
|-----|---------|---|
| 31. | CM1,CM2 | If docked to ISS, perform JOINT EXPEDITED UNDOCKING AND SEPARATION (SODF: JOINT OPS, <u>EMERGENCY RESPONSE</u>).
If utilizing ISS atmosphere, delay vestibule depress until CDR GO (ISS Press \cong 9.5 psia) |
| 32. | CM1,CM2 | Perform EMERGENCY DEORBIT PREP/ENTRY (CONT DEORB, <u>EMERGENCY</u>) |
| | CM3 | Continue with Cabin Pressure Maintenance |

If TIG > 2 hr 40 min or Orb 2,3 deorbit:

- | | | |
|-----|---------|--|
| 33. | CM1,CM2 | Perform LOSS OF CAB PRESS (<u>PWRDN</u>) |
| | CM3 | Continue with Cabin Pressure Maintenance
√MCC for ISS undocking |

Cont next page

Cabin Pressure Maintenance

If $-dP/dT$ EQ > 0.35 (0.18 if SH):

- C5 34. DIRECT O2 vlv – OP
 - C6,MO32M, 35. Don LES, open LEH O2 vlvs, check tabs,
MO69M visor – cl, LES O2 – ON
 - L2 36. O2/N2 CNTLR VLV SYS 1,2 (two) – OP (N2)
 - R1 37. O2 MANF VLV TK1,TK2 (two) – OP (tb-OP)
TK1,TK2,TK3 HTRS A (three) – AUTO
- If any O2 QTY > 60%:
- 38. (Aff) O2 TK HTR B – AUTO
 - MO10W 39. O2 REG INLET SYS 1 vlv – CL
2 vlv – CL >>

Flow Max O2

- R1 40. O2 MANF VLV TK1,TK2 (two) – OP (tb-OP)
TK1,TK2,TK3 HTRS A (three) – AUTO
- If any O2 QTY > 60%:
- 41. (Aff) O2 TK HTR B – AUTO
 - C5 42. DIRECT O2 vlv – OP
 - L2 43. O2/N2 CNTLR VLV SYS 1 – CL (O2)
2 – OP (N2)
O2 XOVR SYS 1 – CL
√2 – OP
 - MO10W 44. 14.7 CAB REG INLET SYS 1 vlv – OP
2 vlv – CL
O2 REG INLET SYS 1 vlv – OP
2 vlv – CL

<p>WARNING Maintain O2 concentration < 29% (CABIN PRESS > 10.3) or PPO2 < 3.0 (CABIN PRESS ≤ 10.3) When PPO2 < 2.2, emergency breathing apparatus reqd</p>

Manage O2 Levels

- MO10W,C5 Using O2 REG INLET SYS 1 vlv and DIRECT O2 vlv:
When CABIN PRESS > 10.3:
| 45. Maintain PPO2 > 2.2 and O2 conc < 29%
- When CABIN PRESS ≤ 10.3:
46. Maintain PPO2 between 2.2 and 3.0
- When PPO2 < 2.2:
C6,MO32M, 47. Don LES, open LEH O2 vlvs, check tabs,
MO69M visor – cl, LES O2 – ON
- MO10W 48. O2 REG INLET SYS 1 vlv – CL
- C5 49. DIRECT O2 vlv – CL
- L2 50. O2 XOVR SYS 1 – OP

Cont next page

8 PSI CABIN MAINTENANCE (Flow N2)

When CABIN PRESS reaches 8:

51. Continue O2 mgmt per step 46
52. Verify time to N2 depletion, perform N2 DEPLETION GRAPH, 4-10, then:

If CABIN PRESS does not remain \geq 7.8 psi (max N2 flow reqd):

MO10W
L2

53. 14.7 CAB REG INLET SYS 1 vlv – CL
54. O2/N2 CNTLR VLV SYS 1,2 (two) – OP (N2)
O2 XOVR SYS 1,2 (two) – OP
55. REG INLET SYS 1,SYS 2 vlv (two) – CL

MO10W

56. Reconfig C/W parameters:

PARAMETER NAME	C/W CH	H/W C/W LO V(LO EU)	ENA/INH
CAB P	4	1.90(7.56)	
O2 FLOW 1	14		INH
2	24		INH
PPO2 A	34	2.20(2.20)	
B	44	2.20(2.20)	
N2 FLOW 1	54		INH
2	64		INH

57. Once PPO2 < 3.00, reconfig C/W parameters:

PARAMETER NAME	C/W CH	H/W C/W HI V(HI EU)
CAB PPO2 A	34	3.00(3.00)
B	44	3.00(3.00)

>>

Cont next page

A4-7

ORB

OPCL/ALL/GEN M,2

TIME TO 8 PSIA NOMOGRAPH

Orbiter + Ext A/L

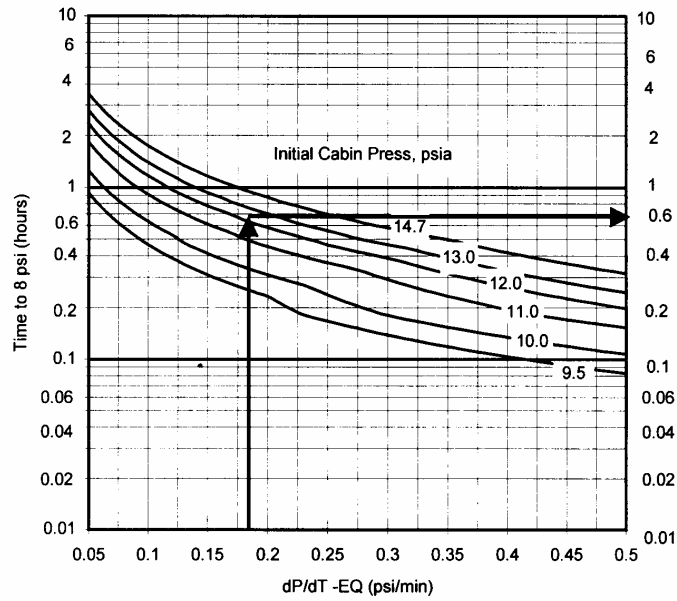

TIME AT 8 PSIA NOMOGRAPH

Orbiter + Ext A/L

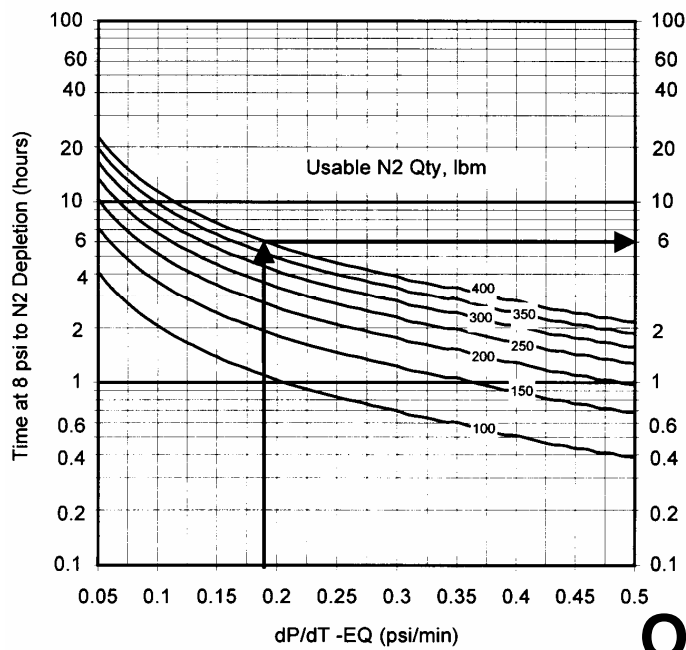

ORB

OPCL/ORB/GEN M

A4-8

8 PSI CABIN MAINTENANCE (Flow N2)

When CABIN PRESS reaches 8:

51. Continue O2 mgmt per step 46
52. Verify time to N2 depletion, perform N2 DEPLETION GRAPH, 4-10, then:

If CABIN PRESS does not remain ≥ 7.8 psi (max N2 flow reqd):

MO10W
L2

53. 14.7 CAB REG INLET SYS 1 vlv – CL
54. O2/N2 CNTLR VLV SYS 1,2 (two) – OP (N2)
O2 XOVR SYS 1,2 (two) – OP

MO10W

55. REG INLET SYS 1,SYS 2 vlv (two) – CL

56. Reconfig C/W parameters:

PARAMETER NAME	C/W CH	H/W C/W LO V(LO EU)	ENA/INH
CAB P	4	1.90(7.56)	
O2 FLOW 1	14		INH
2	24		INH
PPO2 A	34	2.20(2.20)	
B	44	2.20(2.20)	
N2 FLOW 1	54		INH
2	64		INH

57. Once PPO2 < 3.00, reconfig C/W parameters:

PARAMETER NAME	C/W CH	H/W C/W HI V(HI EU)
CAB PPO2 A	34	3.00(3.00)
B	44	3.00(3.00)

>>

Cont next page

B4-7

SHM

OPCL/ALL/GEN M,2

TIME TO 8 PSIA NOMOGRAPH
 Orb + Tunnel Extension + Ext A/L + Tunnel Adapter +
 SpaceHab w/Tunnel/Extension

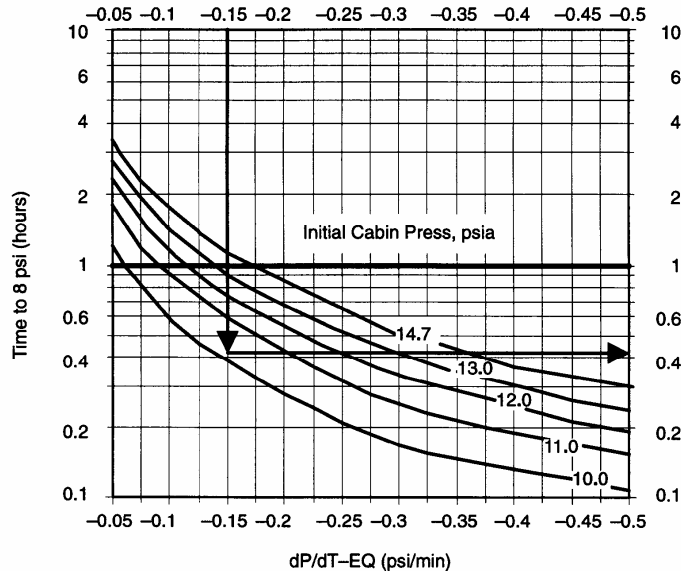

TIME AT 8 PSIA NOMOGRAPH
 Orb + Tunnel Extension + Ext A/L + Tunnel Adapter +
 SpaceHab w/Tunnel/Extension

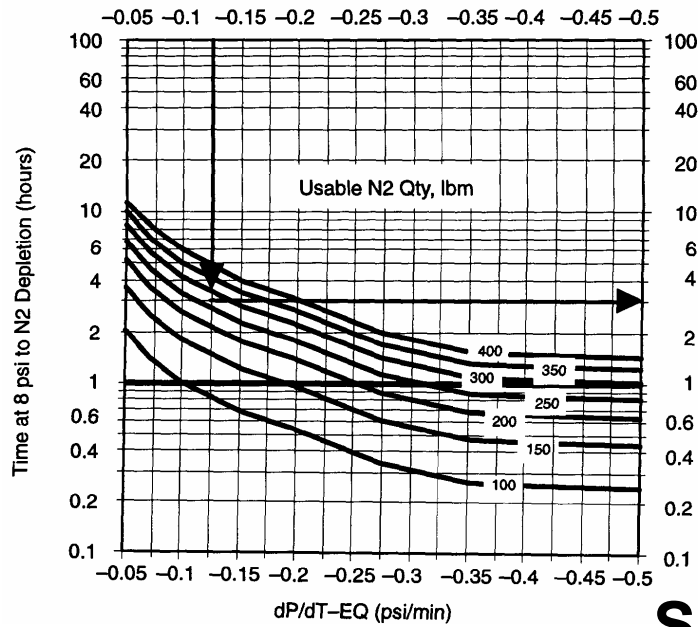

SHM

Tmax Computation

SM 66 ENVIRONMENT

Log:

dP/dT EQ _____ N2 QTY 1 _____
 CAB P _____ N2 QTY 2 _____
 MET _____

Determine latest poss TIG, Tmax, and avail landing sites using PGSC (preferred)/applicable NOMOGRAPH.

If docked to ISS, determine latest poss TIG and Tmax utilizing ISS atmosphere using PGSC, or if PGSC unavail, use Tmax DETERMINATION for UTILIZE ISS ATMOSPHERE (SODF: JOINT OPS, EMERGENCY RESPONSE) in conjunction with NOMOGRAPH (on facing page) to determine Tmax

	<u>Orbiter Only</u>	<u>Utilizing ISS Atmosphere (if reqd)</u>
Time at 9.5 psi (from SODF: JOINT OPS, UTILIZE ISS ATMOSPHERE, <u>EMERGENCY RESPONSE</u>)	N/A	_____ hrs
Time to 8 psi (facing page)	_____ hrs (from current cab press)	_____ hrs (from 9.5 psi)
Time at 8 psi (facing page) (N2 Depletion)	+ _____ hrs	+ _____ hrs
Total Avail Time	= _____ hrs	= _____ hrs
Current MET	+ ____/____:____	+ ____/____:____
Latest TD MET	= ____/____:____	= ____/____:____
Time, TIG to TD	- 0 / 0 1 : 0 0	- 0 / 0 1 : 0 5
Latest TIG,Tmax (MET)	= ____/____:____	= ____/____:____
Landing Site/TIG _____/_____		

NOMOGRAPH Basis:

O2 Flow: on/off at 50 lb/hr after 10 min, with PPO2 > 2.2 psi, % O2 < 29

Orbiter Volume = 2703 ft³

Orbiter + SHM = 5255 ft³

CAUTION

If determining Tmax utilizing ISS atmosphere and ISS hatches OPEN, √MCC for proper dP/dT (Hatch OP dP/dT EQ = {Orbiter Volume/Total Stack Volume} x Hatch CL dP/dT EQ)

03/18/05

N2 DEPLETION GRAPH

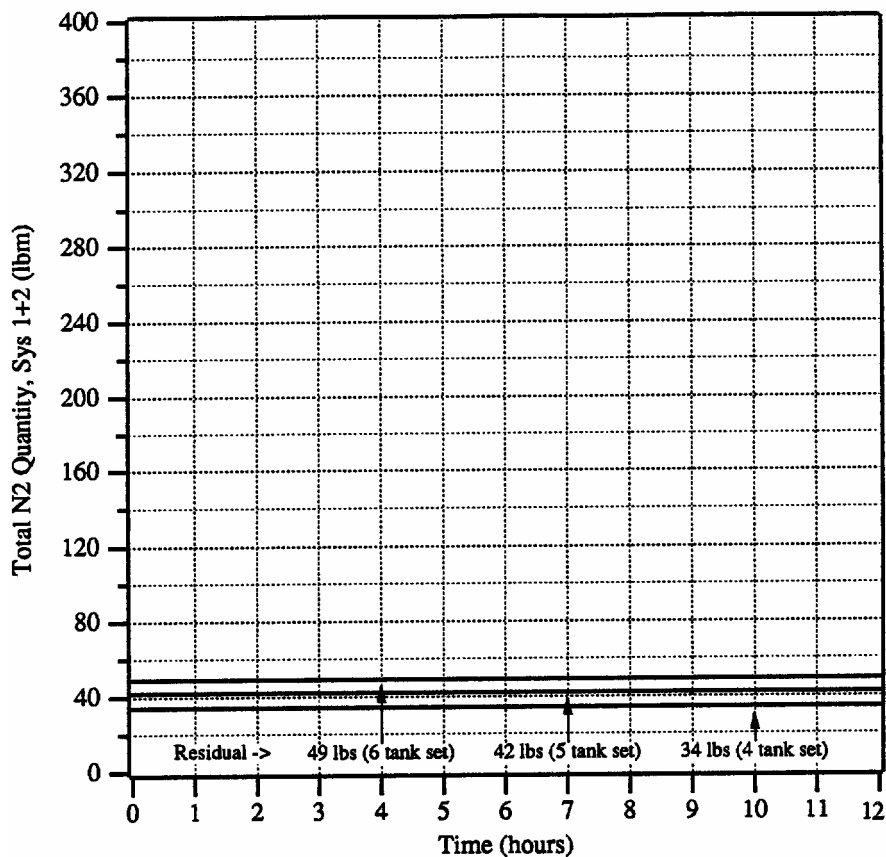

MET ___/___:___ at 8 psia

1. When cabin pressure reaches 8 psia, record MET above, plot total N2 Qty (Sys 1+2) from Spec 66 and start timer
2. Draw point on graph where selected TD time and appropriate residual line intersect
3. Draw a line connecting the initial N2 Qty with point defined in step 2
4. Plot N2 Qty points at various time intervals to verify that N2 will support planned TD time. Note that dispersions in use rate over short time periods are expected
5. If actual N2 use rate is greater than prediction line, select earlier TD time

H2O TK QTY LOW AND DECR

SM 66 ENVIRONMENT

- L1 MO10W
1. If PLBD open: FLASH EVAP CNTLR PRI A,B – OFF
 2. H2O TK N2 ISOL vlv (two) – CL

NOTE

Audible vent and 'S66 WASTE H2O PRES' alert for WASTE H2O PRESS ↓ when performing step 3

- ML26C
3. SPLY H2O GN2 TK VENT vlv – VENT
√TKA SPLY vlv – OP
- When WASTE H2O PRESS ~0 psig (1-2 min):
4. √MCC

EVAP OUT T HIGH

SM 88 APU/ENVIRON THERM

SM SYS SUMM 2

If temp high in only one loop (snsr failed) >>

If PLBD open and RADS in use:

1. Go to MAL, ECLS, 6.4a, EVAP OUT T ↑↓ [1] >>

If PLBD closed or if PLBD open in RAD BYP:

- L1
2. FLASH EVAP CNTLR PRI A(B) – OFF
B(A) – ON (wait 30 sec)
 3. If EVAP OUT T decr: (PRI A(B) CNTL lost) >>

If EVAP OUT T not decr:

- L1
4. FLASH EVAP CNTLR PRI B(A) – OFF
SEC – ON (Hi Load Evap ena)
 5. Minimize ltg (wait 30 sec)

Cont next page

OV103,104

OPCL/ALL/GEN M

N2 DEPLETION
EMER PLBD OPENING (4-13) A4-11

H2O TK QTY LOW
EVAP OUT T HIGH

If EVAP OUT T decr:

If in deorb prep:

O7 6. √TACAN MODE (three) – OFF

O8 7. √RDR ALTM (two) – OFF

8. √MLS (three) – OFF

L1 9. TOP EVAP HTR NOZ (two) – OFF
 DUCT sel – OFF >>

If not in deorb prep >>

If EVAP OUT T not decr (Sec Hi Load failed):

L1 10. HI LOAD EVAP – OFF (Topping Evap ena)

C3 11. MSTR MADS PWR – OFF (wait 30 sec)

If EVAP OUT T decr:

12. Go to LOSS OF HI LOAD EVAP (PWRDN),
 10-33 >>

If EVAP OUT T not decr (all FES lost):

CDR establish RAD flow:

CDR 13. Perform steps 16 thru 19

If PLBD closed, MS open doors ASAP:

MS 14. Perform EMER PLBD OPENING, then:

If in deorb prep:

15. Go to LOSS OF FES (PWRDN), 10-69 >>

If not in deorb prep >>

Establish RAD flow:

CDR L1 16. RAD BYP VLV MODE (two) – AUTO
 CNTLR LOOP (two) – AUTO A(B)

17. FLASH EVAP CNTLR SEC – OFF
 Wait 90 sec

18. √RAD BYP VLV tb (two) – RAD
 √CNTLR OUT TEMP – NORM

19. HI LOAD DUCT HTR sel – OFF
 TOP EVAP HTR NOZ (two) – OFF
 DUCT sel – OFF

OV103,104

H2O TK QTY LOW AND DECR

SM 66 ENVIRONMENT

- L1 MO10W
1. If PLBD open: FLASH EVAP CNTLR PRI A,B – OFF
 2. H2O TK N2 ISOL vlv (two) – CL

NOTE

Audible vent and 'S66 WASTE H2O PRES' alert for WASTE H2O PRESS ↓ when performing step 3

- ML26C
3. SPLY H2O GN2 TK VENT vlv – VENT
√TKA SPLY vlv – OP
- When WASTE H2O PRESS ~0 psig (1-2 min):
4. √MCC

EVAP OUT T HIGH

SM 88 APU/ENVIRON THERM

SM SYS SUMM 2

If temp high in only one loop (snsr failed) >>

If PLBD open and RADS in use:

1. Go to MAL, ECLS, 6.4a, EVAP OUT T ↑↓ [1] >>

If PLBD closed or if PLBD open in RAD BYP:

- L1
2. FLASH EVAP CNTLR PRI A(B) – OFF
B(A) – ON (wait 30 sec)
 3. If EVAP OUT T decr: (PRI A(B) CNTL lost) >>
- If EVAP OUT T not decr:
- L1
4. FLASH EVAP CNTLR PRI B(A) – OFF
SEC – ON (Hi Load Evap ena)
 5. Minimize l_{tg} (wait 30 sec)

Cont next page

OV105
OPCL/ALL/GEN M

**N2 DEPLETION
EMER PLBD OPENING (4-13) B4-11**

**H2O TK QTY LOW
EVAP OUT T HIGH**

If EVAP OUT T decr:

O8 | If in deorb prep:

 6. √RDR ALTM (two) – OFF

L1 | 7. √MLS (three) – OFF

 8. TOP EVAP HTR NOZ (two) – OFF

 DUCT sel – OFF >>

 If not in deorb prep >>

If EVAP OUT T not decr (Sec Hi Load failed):

L1 | 9. HI LOAD EVAP – OFF (Topping Evap ena)

C3 | 10. MSTR MADS PWR – OFF (wait 30 sec)

 If EVAP OUT T decr:

 11. Go to LOSS OF HI LOAD EVAP (PWRDN),

 10-33 >>

 If EVAP OUT T not decr (all FES lost):

 CDR establish RAD flow:

 12. Perform steps 15 thru 18

 If PLBD closed, MS open doors ASAP:

 13. Perform EMER PLBD OPENING, then:

 If in deorb prep:

 14. Go to LOSS OF FES (PWRDN), 10-69 >>

 If not in deorb prep >>

 Establish RAD flow:

CDR L1 | 15. RAD BYP VLV MODE (two) – AUTO

 CNTLR LOOP (two) – AUTO A(B)

 16. FLASH EVAP CNTLR SEC – OFF

 Wait 90 sec

 17. √RAD BYP VLV tb (two) – RAD

 √CNTLR OUT TEMP – NORM

 18. HI LOAD DUCT HTR sel – OFF

 TOP EVAP HTR NOZ (two) – OFF

 DUCT sel – OFF

OV105

B4-12

OPCL/5/GEN M

EMER PLBD OPENING

- | | | |
|------|----|--|
| R13L | 1. | PL BAY DR SYS (two) – ENA |
| CRTX | | <u>X: BFS, SM 63 PL BAY DOORS</u> |
| | 2. | AC POWER ON – ITEM 1 EXEC (*)
AUTO MODE SEL – ITEM 3 EXEC (*)
PBD SW BYPASS – ITEM 14 EXEC (*)
OPEN – ITEM 15 EXEC (*) |
| | 3. | √CENTER LATCHES 5-8,9-12 (two) – blank,OP (~20 sec)
√1-4,13-16 (two) – blank,OP (~20 sec)
√STBD FWD,AFT LATCHES (two) – blank,OP (~30 sec)
√DOOR – RDY,blank,OP (~63 sec)
√PORT FWD,AFT LATCHES (two) – blank,OP (~30 sec)
√DOOR – RDY,blank,OP (~63 sec) |
| | 4. | STOP – ITEM 16 EXEC (*)
PBD SW BYPASS – ITEM 14 EXEC (no *)
AC POWER OFF – ITEM 2 EXEC (*) |
| R13L | 5. | PL BAY DR SYS (two) – DSBL |

EVAP OUT T LOW

SM 88 APU/ENVIRON THERM
SM SYS SUMM 2

- L1 1. If temp low in only one loop (snsr failed) >>
- L1 2. FREON PUMP LOOP 1,2 (two) – OFF
- L1 3. H2O PUMP LOOP 1,2 (two) – ON
- L1 4. FLOW PROP VLV LOOP 1,2 (two) – PL HX (tb-PL)
- L1 5. RAD CNTLR OUT TEMP – HI
- L2 6. FLASH EVAP CNTLR PRI A,B,SEC (three) – OFF
- L2 7. O2 SYS 1,2 SPLY (two) – CL (tb-CL)
- If FREON LOOP RAD OUT T LOW:
 - L1 8. (Unaff) FREON PUMP – B
 - L2 9. (Unaff) O2 SYS SPLY – OP (tb-OP)
 - L2 10. Go to FREON LOOP RAD OUT T LOW, step 7 >> |
- If FREON LOOP 1(2) leaking (Accum Qty decr \geq 1.5%/min):
 - L1 11. FREON PUMP LOOP 1,2 (two) – B
 - If after 60 sec EVAP OUT T = 'L':
 - 12. RAD BYP VLV MODE 1,2 (two) – MAN
 - 13. MAN SEL 1,2 (two) – BYP
(tb-BYP 3 sec)
 - 14. Go to MAL, ECLS, 6.4a, EVAP OUT T $\uparrow\downarrow$ 47 >>
- If FREON LOOP 1(2) not leaking:
 - If no comm:
 - 15. FREON PUMP LOOP 1,2 (two) – B
 - NH3 CNTLR A,B (two) – SEC/ON
 - If after 60 sec EVAP OUT T = 'L':
 - 16. RAD BYP VLV MODE 1,2 (two) – MAN
 - 17. MAN SEL 1,2 (two) – BYP
(tb-BYP 3 sec)
 - 18. Go to MAL, ECLS, 6.4a, EVAP OUT T $\uparrow\downarrow$ 46

H2O SPLY PRESS HIGH

SM 69 FUEL CELLS
SM 66 ENVIRONMENT

- If the FC H2O PRI LN T and associated FC H2O VLV T are converging or within 5 degF of each other for multiple FCs:
If SUPPLY H2O TKB INLET and XOVR VLV closed (tb-CL or bp):
- R11L 1. cb MNB SPLY H2O TKB INLET – cl
 - ML86B:A 2. MNC SPLY H2O XOVR VLV – cl
 - R11L 3. SPLY H2O TKA OUTLET – CL (tb-CL)
 - 4. TKB INLET – OP (tb-OP)
 - 5. XOVR VLV – OP (tb-OP)
 - 6. √SPLY H2O TKA,TKB,TKC INLET (three) – OP (tb-OP)
 - 7. √XOVR VLV – OP (tb-OP)
 - ML31C 8. √SPLY H2O TKD INLET – OP (tb-OP)
 - CRT If SUPPLY H2O PRESS decr or < 40: >>
 - L1 If SUPPLY H2O PRESS not decr or ≥ 40:
 - 9. FLASH EVAP CNTLR PRI A,B,SEC (three) – OFF
 - 10. RAD CNTLR OUT TEMP – HI
 - O1 When EVAP OUT T ~50:
 - L1 11. FLASH EVAP CNTLR PRI B – ON
 - 12. Go to MAL, ECLS, 6.5d, H2O SPLY PRESS ↑
1 >>
- Else:
13. Go to MAL, ECLS, 6.5d, H2O SPLY PRESS ↑ 3

OPCL/ALL/GEN M

EVAP OUT T LOW

4-15

H2O SPLY P HIGH

FREON FLOW LOW

SM 88 APU/ENVIRON THERM
SM SYS SUMM 2

- 1. Switch pumps in aff loop(s)
- If flow still low in only one loop:
 - 2. Go to MAL, ECLS, 6.4b, FREON FLOW LOW 1 >>
- If flow still low in both loops:
 - L1 3. FLOW PROP VLV LOOP 1,2 (two) – ICH (tb-ICH)
If not in OPS 2:
 - Prepare to deorb:
 - L2 4. FREON PUMP LOOP 1,2 (two) – OFF
 - C3 5. $\sqrt{O_2}$ SYS 1,2 SPLY (two) – OP (tb-OP)
 - R11U 6. MSTR MADS PWR – OFF
 - 7. FC PURGE HTR – ON
VLVS (three) – OP
 - 8. Go to LOSS OF 2 FREON LOOPS
(PWRDN), 10-49 >>
 - If in OPS 2:
 - If AFT cp FLOW in both loops < 200 lb/hr:
 - Prepare to deorb:
 - L1 9. If AFT cp FLOW < 100 lb/hr:
FREON PUMP LOOP 1,2
(two) – OFF
 - L2 10. $\sqrt{O_2}$ SYS 1,2 SPLY (two) – OP (tb-OP)
 - C3 11. MSTR MADS PWR – OFF
 - R11U 12. FC PURGE HTR – ON
VLVS (three) – OP
 - 13. Go to LOSS OF 2 FREON LOOPS
(PWRDN), 10-49 >>
 - If AFT cp FLOW in either loop > 200 lb/hr:
 - 14. Go to MAL, ECLS, 6.4b, FREON FLOW
LOW 1

FREON LOOP RAD OUT T LOW SM 88 APU/ENVIRON THERM
SM SYS SUMM 2

- L1 1. If EVAP OUT T not decr after 60 sec (snsr failed) >>
 - 2. (Aff) FREON PUMP – OFF
 - 3. H2O PUMP LOOP 1,2 (two) – ON
 - L2 4. FLOW PROP VLV LOOP 1,2 (two) – PL HX (tb-PL)
 - L1 5. (Aff) O2 SYS SPLY – CL
 - 6. FLASH EVAP CNTLR PRI A,B,SEC (three) – OFF
 - 7. (Aff) RAD BYP VLV MODE – MAN
 - 8. CNTLR LOOP – AUTO B
- After 10 sec:
- 9. (Aff) RAD BYP VLV MODE – AUTO
 - 10. (Aff) FREON PUMP LOOP – B
 - 11. √(Aff) RAD BYP VLV tb – RAD
- If RAD OUT T LOW continues:
- 12. (Aff) FREON PUMP LOOP – OFF
 - 13. √MCC (mult failures) >>
- If FES reqd:
- 14. Perform TOPPING FES STARTUP (ORB OPS, ECLS), then:
- L2 15. (Aff) O2 SYS SPLY – OP

FREON LEAK SM 88 APU/ENVIRON THERM
BFS SM 0 THERMAL

- CRT If FREON LOOP ACCUM QTY decr, then immediately:
- L2 1. FREON ISOL MODE – MAN
 - 2. (Aff) FREON ISOL LOOP – ISOL (hold for 5 sec)
 - 3. Go to MAL, ECLS, 6.4f, ACCUM QTY ↓ 11

OPCL/ALL/GEN M,5

FREON FLOW LOW

4-17

**FREON LOOP RAD
FREON LEAK**

LEAKING/EMPTY HALON BOTTLE

If docked to ISS and hatches open:

1. Perform JOINT EMERGENCY EGRESS (SODF: JOINT OPS, Cue Card) to isolate ISS, then:

If FIRE SUPPR AV BAY 1(2,3) pb It on:

2. Go to POST-FIRE CABIN CLEANUP, steps 16-24 only for Av Bay 1(2,3) >>

If Portable Halon Bottle leaking:

3. Position Halon bottle up to Av Bay 3 fire port. Secure body position as reqd

NOTE

Halon discharge will be propulsive

4. Discharge portable FIRE EXTGHR into Av Bay 3 fire port. Full discharge will require 90 sec. Report actual discharge duration to MCC
5. Stow empty bottle (Wet Trash)
6. Go to POST-FIRE CABIN CLEANUP, steps 16-24 only for Av Bay 3 >>

ODS POST-FIRE ACTIONS

Continue from ODS VOLUME FIRE/SMOKE (Cue Card), on MCC call

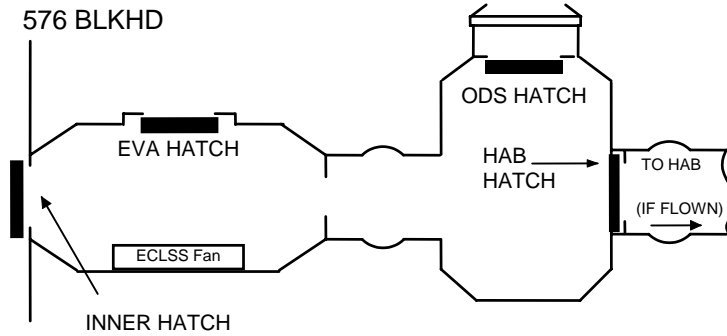

CONFIG A

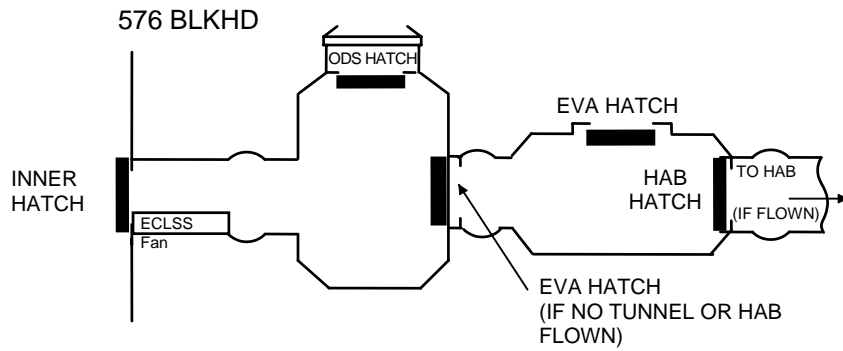

CONFIG B

Cont next page

OPCL/ALL/GEN M

- CM1 1. Don QDM with 14-ft extension O2/Comm line
All other crewmembers: Don QDMs

NOTE

CM2 can perform cab air monitoring per MAL, ECLS FRP-2, POST-FIRE CABIN CLEANUP CONTINUATION at any time

- C6,MO32M, MO69M 2. √LEH O2 vlv (eight) – OP
C7 3. √LEH O2 SPLY 1,2 vlv (two) – OP
MO10W 4. 14.7 CAB REG INLET SYS 1(SYS 2) vlv – CL
Inner Hatch 5. Untether Equal vlv cap (one) from INNER HATCH vlv, for use in step 6
Open HATCH per decal

NOTE

Exit airlock volume IMMED after step 6 complete. Expect cab dP/dT msg

- Hatch ON CLOSEST HATCH EXPOSED TO VACUUM,
6. Equal vlv cap (one) – vent,remove
Equal vlv (one) – NORM, then IMMED
INNER HATCH Equal vlv cap (one) – install onto HATCH Equal vlv

- Inner Hatch 7. Close HATCH:
Position handle to preclosing posn per decal
Hatch – rotate about hinge and push
Handle – CCW to LATCH
Lock lever to LOCKED

- CRT 8. SM 177 EXTERNAL AIRLOCK

NOTE

Expect 'S177 EXT A/L PRES' msg

- Inner Hatch When EXT AIRLOCK P \cong 0, on MCC GO,
Equal vlv (two) – EMER

NOTE

Expect poss 'S66 CABIN PRES', PPO2 A(B) msgs and KLAXON

Cont next page

- | | | |
|-------------|-----|--|
| CM1 | 9. | When ΔP across INNER HATCH < 0.5 psi,
Open HATCH per decal, then IMMED |
| Hatch | 10. | ON CLOSEST HATCH EXPOSED TO VACUUM,
Equal vlv cap (two) – remove
Equal vlv (two) – OFF
Equal vlv cap (two) – reinstall orig
vlv caps |
| Inner Hatch | 11. | Retether, reinstall orig Equal vlv cap (one) |
| CM2 | 12. | Perform cab air monitoring per MAL, <u>ECLS FRP-2</u> ,
POST-FIRE CABIN CLEANUP CONTINUATION if
not already done. Do not perform cab cleanup
unless CPA readings out of limits. On MCC call,
doff QDMs |
| | 13. | On MCC call, ARLK Fan and ODS avionics may be
repwr'd, PCS reconfigured, and PL ISOL vlv – OP
(cap removed) |

POST-FIRE CABIN CLEANUP (Cab and Av Bay Fires)

Continue from FIRE/SMOKE Cue Card:

NOTE

This proc is to be performed
simo by two crewmembers

- CM1** L1
1. $\sqrt{\text{CAB FAN A(B) - ON}}$
 2. Unstow CSA-CP
 3. MODE pb – press, hold until 'RELEASE' displayed; wait ~1 min for nominal display
 4. Sampling Pump sw – ON
 5. Monitor cab atmosphere in vicinity of fire and report results to MCC
- If HCN > 2.1, HCL > 1.0, or CO > 18 ppm:
- LiOH Box
6. If HCL < 5 ppm, install ATCO and one fresh LiOH canister
 7. If HCL > 5 ppm, install two fresh LiOH canisters
- L1
MD44F
ML86B:B
MA73C:E
WCS
8. CAB TEMP CNTLR – OFF
Pin Cab temp cntl act link – FULL COOL
 9. $\sqrt{\text{cb MNA, MNB WCS CNTLR (two) - cl}}$
 $\sqrt{\text{AC1,2 WCS FAN SEP 1,2 (six) - cl}}$
 10. $\sqrt{\text{FAN SEP SEL sw - 1}}$
- If Av Bay 1 Fire:
11. HOSE BLOCK to SEP 2
 12. FAN SEP SEL sw – 2
 13. MODE – COMMODE/MANUAL/EMU
 14. COMMODE CNTL – PULL UP
– PUSH FWD
15. Go to MAL, ECLS FRP-2, POST-FIRE CABIN CLEANUP CONTINUATION
-

- CM2**
- If Av Bay fire, set up for Av Bay purge:
If docked with ISS:
16. $\sqrt{\text{MCC for attitude control handover}}$
 17. Obtain from Cont Hose & Cable Kit (Window Shade Bag):
Free Fluid Nozzle
20-ft Y/Y Hose
Gray Tape
 18. Connect Free Fluid Nozzle to Y/Y Hose
 19. Insert tip of Free Fluid Nozzle into fire port of Av Bay
 20. Secure nozzle and hose with Gray Tape

Cont next page

- If attitude control handover reqd:
- 21. √Handover complete prior to initiating purge in following step
 - WCS 22. Mate free end of Y/Y Hose to Vacuum Vent QD
 - 23. √VAC VLV – OP
 - ML86B:A 24. √cb MNA(MNB) H2O LINE HTR A(B) – cl
 - :B √MNA,MNB VAC VENT ISOL VLV (two) – cl
 - √MNB VAC VENT NOZ HTR – cl
 - ML31C 25. √VAC VENT ISOL VLV BUS SEL – MNA
 - √NOZ HTR – ON
 - √ISOL VLV CNTL – OP (tb-OP)
 - 26. Report to MCC: “Av Bay purge is initiated”

ISS C&W TOX ATM

SM 211 ISS C&W

If docked to ISS and hatches open:

- 1. Perform JOINT EMERGENCY EGRESS (SODF: JOINT OPS, Cue Card) to isolate ISS, then:

If ISS AMMONIA LEAK:

- 2. Go to MAL, ECLS FRP-5, CABIN AMMONIA CONTAMINATION CLEANUP (ISS AMMONIA LEAK) >>

√MCC for further actions

OPCL/ALL/GEN M,3

**POST-FIRE
CABIN CLEANUP**

4-23

**ISS C&W TOX ATM
PCS SCHEMATIC (4-24)**

PRESSURE CONTROL SYSTEM
ORBIT

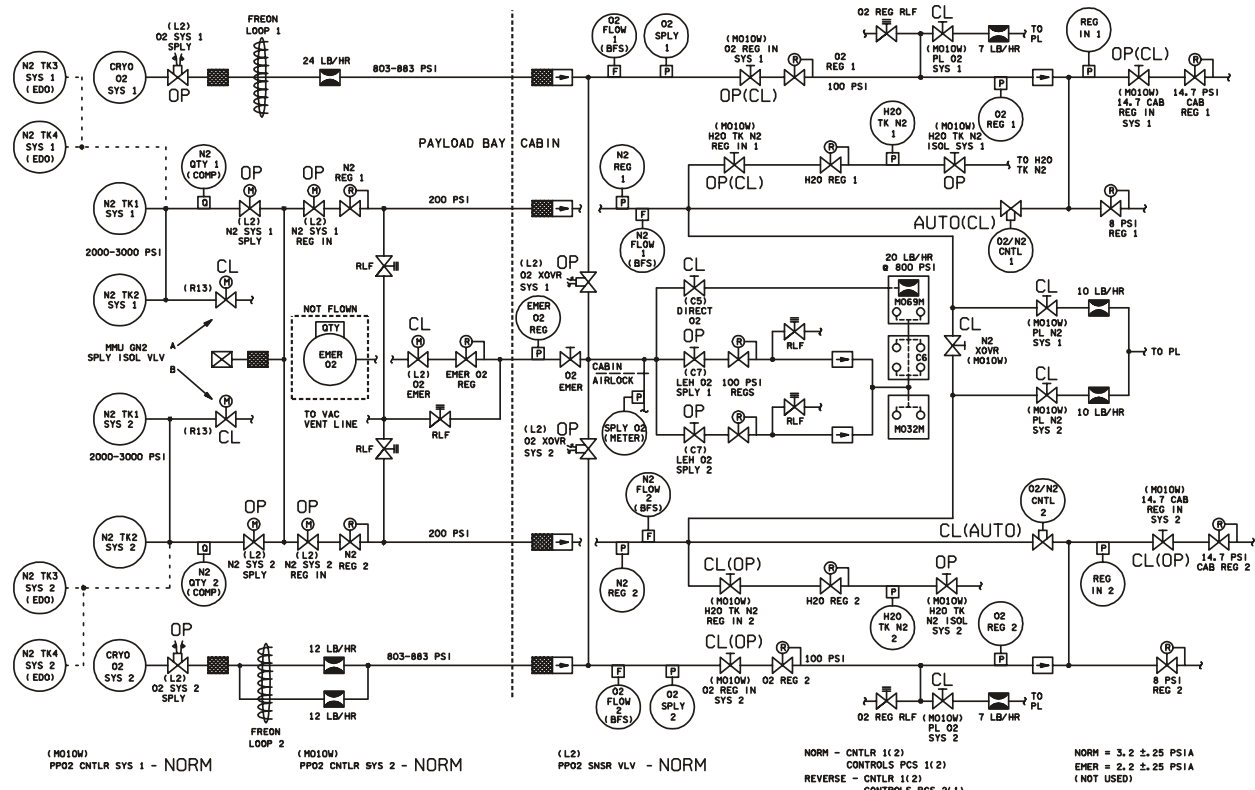

DATE 11/29/04

480330419.SCH 3

4-24

OPCL/ALLGEN M



ELECTRICAL POWER SYSTEM

EPS



5-1

OPCL/ALL/GEN M

MN BUS UNDERVOLTS/FC VOLTS

SM SYS SUMM 1

If MN VOLTS < 26.4, FC VOLTS < 26.6, FC AMPS > 480 (2 of 3)
(short or degraded FC):

1. MSTR MADS PWR – OFF

If aff FC/MN BUS tied:

2. Untie buses

If short eliminated and MN bus not pwr'd after untie:

3. Go to aff MN BUS LOSS ACTION (MN bus or tie bus short) >>

If short eliminated and all MN buses pwr'd after untie (tie bus short) >>

If short not eliminated, then:

If aff FC/MN BUS connected to PL PRI BUS:

4. PL PRI (three) – OFF (tb-OFF)

If short eliminated (pri PL short):

If a MN bus not pwr'd:

5. Perform BUS TIE (Cue Card), then:

6. Go to PL PWRDN >>

If aff MN BUS connected to PTU:

: 7. PTU/MN BUS – OFF (tb-OFF) (pnl A15)

: OPCU CONV – OFF

: If short eliminated (short on PTU/MN Bus connection):

: If a MN bus not pwr'd:

: 8. Perform BUS TIE (Cue Card) >>

: Otherwise:

L 9. >>

10. (Aff) ESS BUS SOURCE FC – OFF
FC/MN BUS – OFF (tb-OFF)

If aff FC VOLTS < 32 (FC short):

11. (Aff) FC REAC VLV – CL (tb-CL)

12. Go to FC SHUTDN (Cue Card) (do not stop FC until COOL
P < 15 and STACK T < 243) >>

If FC VOLTS ≥ 32 (bus short):

CAUTION

Do not bus tie to shorted bus

13. Go to aff MN BUS LOSS ACTION >>

EPS

Cont next page

- If MN VOLTS < 26.4 and FC VOLTS > 32 and FC AMPS < 20
 (FC disconnect, check APUs):
14. MSTR MADS PWR – OFF
 - If PL PRI BUS pwr lost due to FC disconnect:
 15. PL PRI (three) – OFF (tb-OFF)
 16. (Aff) FC/MN BUS – ON (tb-ON)
 - If PL PRI disconnected in step 15:
 17. Perform PL PWRDN, then:
 - If FC3 aff:
 18. PL PRI FC3 – ON (tb-ON)
MNC – ON (tb-ON)
 - If first FC prob:
 19. Perform BUS TIE (Cue Card), then:
 - If aff FC VOLTS still > 32:
 20. Go to FC SHUTDN (Cue Card) >>
 21. (Aff) AC BUS SNSR – OFF,AUTO TRIP
 22. GNC I/O RESET >>
 - If second FC failure and aff MN BUS not recovered:
 23. PL PRI (three) – OFF (tb-OFF)
 - If aff MN BUS connected to PTU:
 24. PTU/MN BUS – OFF (tb-OFF) (pnl A15)
OPCU CONV – OFF
 25. Go to 2nd FC SHUTDN >>
 - If neither:
 26. Go to MAL, EPS, 7.3b, FUEL CELL VOLTS ↑↓, FUEL CELL AMPS ↑↓, MAIN BUS V A(B,C) ↑↓ 1

OPCL/ALL/GEN M,2

**MN BUS UNDERVOLTS/
FC VOLTS**

3Φ AC MTR STOPPED (5-4) 5-3

AC VOLTS (5-5)

3Φ AC MOTORS STOPPED

(No AC VOLTS Alarm: Φ Shift)

WARNING

If no FC Coolant Pump within 9 min, go to aff
AC BUS (2 or 3 Φs) BUS LOSS ACTION

1. Determine aff AC BUS:
FC1 and FREON PUMP 2B: AC1
FC2 and FREON PUMP 1B: AC2
FC3 and CAB FAN A: AC3
2. (Aff) FC – STOP
If AC3 aff:
 3. AV BAY 3 FAN B – OFF
A – ON
CAB FAN A – OFFIsolate aff ΦB(ΦC,ΦA):
 4. (Aff) cb AC CONTR – cl
INV/AC BUS – OFF (tb-OFF)If AC1(2,3) aff and AV BAY FAN 3(2,3) ΔP ≥ 0.5:
 5. Go to step 12 (bad Φ isolated)
6. (Aff) INV/AC BUS – ON (tb-ON)
cb AC CONTR – op
7. Repeat from step 4 for ΦC(ΦA), then:

Drop aff AC bus (three Φ s):

8. (Aff) cb AC CONTR (three) – cl
9. INV/AC BUS – OFF (tb-OFF)
10. INV PWR – OFF (tb-OFF)
11. Go to aff AC BUS (2 or 3 Φ s) BUS LOSS ACTION >>

Bad Φ isolated:

12. (Aff) INV PWR – OFF (tb-OFF)
cb AC CONTR – op
FC – START (10 sec or ΔP tb-gray)
13. If AC3 aff: CAB FAN B – ON
14. Go to aff MAL, EPS SSR BUS LOSS ACTION

AC VOLTS

SM 67 ELECTRIC

SM SYS SUMM 1

1. If AC OVERLOAD F7 light or 'S67 AC OVLD' msg: Go to AC OVERLOAD >>

If single Φ AC VOLTS > 123 or between 10 and 110 (confirm with F9 meter):

2. (Aff) cb AC CONTR – cl
INV/AC BUS – OFF (tb-OFF)
INV PWR – OFF (tb-OFF)
cb AC CONTR – op

If other Φ AC VOLTS < 110 or AC AMPS > 14:

3. Go to step 6

If other Φ AC AMPS > 10:

- : 4. Isolate shorted Φ : Open all aff AC1(2,3) three- Φ ganged
: cbs and all aff AC1(2,3) Φ A(B,C) single- Φ cbs as follows:

total number of cbs to √ open

BUS	L4	MA73C
AC1 3Φ	1	5
ΦA	16	5
ΦB	16	4
ΦC	13	5
AC2 3Φ	0	9
ΦA	15	5
ΦB	16	4
ΦC	14	5
AC3 3Φ	1	7
ΦA	15	3
ΦB	16	3
ΦC	13	3

5. Go to aff MAL, EPS SSR BUS LOSS ACTION >>
- If multi Φ AC VOLTS < 110:
- : If any AC AMPS > 14 (unannun OVLD):
 - : 6. (Aff) cb AC CONTR (three) – cl
 - : INV/AC BUS – OFF (tb-OFF)
 - : INV PWR – OFF (tb-OFF)
 - : cb AC CONTR (three) – op
 - : 7. Go to aff BUS LOSS ACTION >>
 - : If all AC AMPS < 1 (FPC bus lost):
 - L 8. Go to aff BUS LOSS ACTION >>
- If all AC VOLTS between 110 and 123:
9. Go to MAL, EPS, 7.5a, AC VOLTS 1(2,3) ↓↑ 6

AC OVERLOAD

SM 67 ELECTRIC
SM SYS SUMM 1

If any AC VOLTS < 110 or AC AMPS > 14 (OVLD):

If single Φ :

1. (Aff) cb AC CONTR – cl
INV/AC BUS – OFF (tb-OFF)
INV PWR – OFF (tb-OFF)
cb AC CONTR – op

If other Φ AC VOLTS < 110 or AC AMPS > 14:

2. Go to step 5
3. Isolate shorted Φ : Open all aff AC1(2,3) three- Φ ganged cbs and all aff AC1(2,3) Φ A(B,C) single- Φ cbs as follows:

total number of cbs to \sqrt open

BUS	L4	MA73C
AC1 3 Φ	1	5
Φ A	16	5
Φ B	16	4
Φ C	13	5
AC2 3 Φ	0	9
Φ A	15	5
Φ B	16	4
Φ C	14	5

Cont next page

OPCL/ALL/GEN M

ESS BUS V LOW (5-8)

5-7 AC OVERLOAD
CNTL BUS V LOW/RPC (5-9)

AC3 3Φ	1	7
ΦA	15	3
ΦB	16	3
ΦC	13	3

4. Go to aff MAL, EPS SSR BUS LOSS ACTION >>
- If multi Φ (bus short):
5. (Aff) cb AC CONTR (three) – cl
 INV/AC BUS – OFF (tb-OFF)
 INV PWR – OFF (tb-OFF)
 cb AC CONTR (three) – op
 6. Go to aff BUS LOSS ACTION >>
- If all AC VOLTS between 110 and 123 and AC AMPS < 14:
7. Go to MAL, EPS, 7.5b, AC OVLD 1(2,3) ↓ 6

ESS BUS VOLTS LOW

If verified by F9 voltmeter:

	1BC	2CA	3AB
If aff cb op	MNA CONTR (pnl O15:B)	MNB CONTR (pnl O16:B)	MNC CONTR (pnl O14:B)
1. (Aff) cb – op	MNA CONTR (pnl O13:A)	MNB CONTR (pnl O13:C)	MNC CONTR (pnl O13:E)
2. (Aff) cb – cl	MNA CONTR (pnl O15:B)	MNB CONTR (pnl O16:B)	MNC CONTR (pnl O14:B)

3. Perform FC SHUTDN (Cue Card) [FC/MN BUS A(B,C), and MN BUS TIE A(B,C) tbs lost], then:
4. Go to aff BUS LOSS ACTION (ESS)

CNTL BUS V LOW/CNTL BUS RPC

SM SYS SUMM 1
SM 67 ELECTRIC

WARNING
If VISIBLE FIRE/SMOKE AT ANY TIME, cb CNTL BUS AB1/2/3(BC1/2/3,CA1/2/3) – op (pnl R14:B)

NOTE

CNTL BUS PWR sws must be held continuously in the RESET posn to unpwr bus(es)

1. Identify BUS (√BUS LOSS ID)
- ◆ 2. If one CNTL BUS RPC tripped (*):

Aff CNTL BUS:

AB1(2,3)

	Tripped RPC (*)	Action (for RESET, hold w/sw reten device)
3.	A	R1 CNTL BUS PWR MNB – RESET R14:B cb CNTL BUS AB1/2/3 – op
4.	B	R1 CNTL BUS PWR MNA – RESET R14:B cb CNTL BUS AB1/2/3 – op

BC1(2,3)

	Tripped RPC (*)	Action (for RESET, hold w/sw reten device)
5.	B	R1 CNTL BUS PWR MNC – RESET R14:B cb CNTL BUS BC1/2/3 – op
6.	C	R1 CNTL BUS PWR MNB – RESET R14:B cb CNTL BUS BC1/2/3 – op

Cont next page

CA1(2,3)

	Tripped RPC (*)	Action (for RESET, hold w/sw reten device)
7.	C	R1 CNTL BUS PWR MNA – RESET R14:B cb CNTL BUS CA1/2/3 – op
8.	A	R1 CNTL BUS PWR MNC – RESET R14:B cb CNTL BUS CA1/2/3 – op

◆ If no CNTL BUS RPC tripped (no *):

	aff CNTL BUS	Panel R1 action (hold w/sw reten device)
9.	AB1(2,3)	CNTL BUS PWR MNA,MNB (two) – RESET
10.	BC1(2,3)	CNTL BUS PWR MNB,MNC (two) – RESET
11.	CA1(2,3)	CNTL BUS PWR MNA,MNC (two) – RESET

If CNTL BC2 unpwr:

C3 12. S-BD PM CNTL – PNL,CMD

If CNTL BC1 and BC2 unpwr, comm will be UHF only

For all CNTL V < 25.0:

13. Perform BUS LOSS ACTION (CNTL), then, on MCC call only, perform MAL, EPS SSR-100 thru SSR-108, then:
 14. Perform CONTROL BUS PWRDN (IFM, PROCEDURES A THRU F) for shorted bus, then:
 15. If reqd, back out of BUS LOSS ACTION for regained buses, then:
 16. Perform MAL, EPS SSR-100 thru SSR-108 for shorted bus, then:
- If pwr reqd (<3 sec) for crit function:
17. Hold crit function sw
- For tripped RPC:
- R1 18. CNTL BUS PWR MNA(MNB,MNC) – RESET (1 sec), then dn

FC COOLANT PUMP ΔP LOW

SM 69 FUEL CELLS
SM SYS SUMM 1

If other 3Φ AC motors aff and AC VOLTS OK:

1. Go to 3Φ AC MOTORS STOPPED >>
2. √(Aff) FC CNTLR – ON
(O15,O16) FC – START (10 sec or ΔP tb-gray)
If FC EXIT T > 164 and not decr, or
H2 PUMP < 0.3 or > 0.8, or
RDY tb – bp (30 sec after START) or
L4:C (aff) FC PUMPS cb(s) – op:
 3. Go to FC SHUTDN (Cue Card) >>If FC H2 PUMP status norm, FC EXIT T norm, and RDY
tb – gray:
N/A (snsr failed)

FC1(2,3) H2 PUMP ↑↓

SM 69 FUEL CELLS
SM SYS SUMM 1

If other 3Φ AC motors aff and AC VOLTS OK:

1. Go to 3Φ AC MOTORS STOPPED >>
- If FC COOL PUMP ΔP tb – bp:
2. Go to FC COOLANT PUMP ΔP LOW >>
- If FC H2 PUMP between 0.8 and 2.0 or between 3.0 and 4.6:
3. Perform BUS TIE (Cue Card), then:
 4. Go to MAL, EPS, 7.1c, H2 PUMP ↑↓ [1] >>
- If FC H2 PUMP < 0.2 or between 2.0 and 3.0 or > 4.6:
5. Note AC1(2,3) ΦA,B,C AMPS
 6. Perform FC SHUTDN (Cue Card), then:
 7. Go to MAL, EPS, 7.1c, H2 PUMP ↑↓ [7]

OPCL/ALL/GEN M

FC REACTANT VLV CLOSED

SM 69 FUEL CELLS
SM SYS SUMM 1

- R1 1. FC REAC VLV (three) – OP (tb-OP or hold 1 sec max)
 2. Perform BUS TIE (Cue Card), then:
 If no joy on REAC open:
C3 3. √cb FC REAC VLV CL ENA (three) – op
R1 4. FC REAC VLV (three) – OP (tb-OP or hold 10 sec)
 If aff FC COOL P decr or < 50 within 7 min:
 | 5. Go to aff FC SHUTDN (Cue Card) >>
 If aff COOL P > 50 and steady after 7 min:
 6. Aff buses – untie if reqd

FC COOL P

SM 69 FUEL CELLS
SM 66 ENVIRONMENT

1. Perform BUS TIE (Cue Card), then:
If COOL P > 75, incr, and not 100 (H),
| or FC COOL PUMP = ΔP (intermittent),
| or STACK/EXIT T unstable,
| or FC FLOW O2(H2) > 8.4(1.1):
| 2. Go to FC SAFING >>
If FC COOL P < 25 or > 75 and steady:
| 3. Go to MAL, EPS, 7.3e, FUEL CELL COOL P ↑↓ [8] >>
If FC COOL P between 25 and 50:
| If FC COOL P < (SUPPLY H2O PRESS + 10):
| 4. Perform FC SHUTDN (Cue Card), then:
| 5. Go to MAL, EPS, 7.3e, FUEL CELL COOL P ↑↓ [45] >>
| 6. Go to MAL, EPS, 7.3e, FUEL CELL COOL P ↑↓ [30] >>

FC H2O RLF NOZ TEMP ↑↓

SM 69 FUEL CELLS
SM 66 ENVIRONMENT

- R11U
- If H2O RLF NOZ T A and B < 150:
 - If more than one FC H2O LN T and H2O VLV T converging or within 5 degF of each other (mult FCs relieving):
 - If H2O SUPPLY PRESS ≥ 40:
 - 1. Go to H2O SPLY PRESS HIGH (ECLS), 4-15 >>
 - If H2O SUPPLY PRESS < 40:
 - 2. Initiate preparations for next PLS entry >>
 - If one FC H2O LN T and H2O VLV T converging or within 5 degF of each other (single FC relieving):
 - 3. Go to BUS TIE (Cue Card) >>
 - If no FC H2O LN T and H2O VLV T converging (HTR inop, NOZ frozen, or sw failure):
 - 4. FC H2O RELIEF HTR – A AUTO(B AUTO) >>
 - If H2O RLF NOZ T A and B (both) > 425 (HTR fail on):
 - 5. √MCC

OPCL/ALL/GEN M

FC REAC VLV CLOSED
FC COOL P

5-13

FC H2O RLF NOZ T ↑↓

FC DELTA V 1(2,3)

SM SYS SUMM 1
SM 69 FUEL CELLS

1. Perform BUS TIE (Cue Card), then:
If aff FC(H2O LINE) pH ↓ or FC ΔV incr:
 2. Perform FC SAFING, then:
 3. If pH ↓: Go to MAL, EPS, 7.3a, FC/H2O LINE pH HIGH [6] >>
- If no aff FC(H2O LINE) pH ↓ and FC ΔV not incr:
 4. Two min after bus tie, record FC ΔAMPS between aff and tied FC; monitor for 20 min
- If change in FC ΔAMPS > 12 or FC ΔV incr:
 5. Go to FC SAFING >>
- If change in FC ΔAMPS ≤ 12, FC ΔV not incr, and no MCC:
 6. SM 60 SM TABLE MAINT
Reset limits for (aff) FC ΔAMPS 1(2,3):
ITEM 1 +0 9 2 2 1 4 2(0922143,0922144) EXEC
2 ±(FC ΔAMPS - 40) EXEC
3 ±(FC ΔAMPS + 40) EXEC

FC pH HIGH or H2O LINE pH HIGH

SM SYS SUMM 1
SM 69 FUEL CELLS

- If FC1(2,3) pH ↓:
1. Perform BUS TIE (Cue Card), then:
 - If aff FC ΔV SS 1(2,3) ≥ 150 and incr:
 2. Perform FC SAFING, then:
 3. Go to MAL, EPS, 7.3a, FC/H2O LINE pH HIGH [6] >>
 4. SPLY H2O TKA INLET,OUTLET (two) – CL (tb-CL)
√TKB INLET – CL [(tb-CL(bp))]
TKC OUTLET – CL (tb-CL)
TKD INLET – CL (tb-CL)
 5. Go to MAL, EPS, 7.3a, FC/H2O LINE pH HIGH [1]

FC SHUTDN (1st)

SM SYS SUMM 1

WARNING
If FC Coolant Pump lost,
Emergency FC use OK for 9 min

1. MSTR MADS PWR – OFF
2. If not tied: Perform BUS TIE (Cue Card), then:
If ORB (not deorb prep), kW > 18:
MN BUS TIE (three) – ON
3. ESS BUS SOURCE FC – OFF
FC/MN BUS – OFF (tb-OFF)
FC – STOP (COOL PUMP Δ P tb-bp or 1 sec) (expect FDA msgs)
4. FC REAC VLV – CL (tb-CL)
Go to LOSS OF 1 FC (PWRDN), 10-39

2nd FC SHUTDN

SM SYS SUMM 1

WARNING
If FC Coolant Pump lost,
Emergency FC use OK for 6 min

1. MSTR MADS PWR – OFF
2. If aff FC pwr one MN bus: Go to step 5
3. MN BUS TIE (three) – OFF (tb-OFF)
4. Perform BUS TIE (Cue Card) to good FC/BUS, then:
5. ESS BUS SOURCE FC – OFF
6. FC/MN BUS – OFF (tb-OFF)
7. FC – STOP (COOL PUMP Δ P tb-bp or 1 sec)
8. FC REAC VLV – CL (tb-CL)
9. Go to LOSS OF 2nd FC (PWRDN), 10-41

OPCL/ALL/GEN M

FC DELTA V 1(2,3)
FC(H2O LINE) pH HIGH 5-15

FC SHUTDN (1st)
2nd FC SHUTDN

BUS TIE (do not tie bus short, check APUs)

If MN Volts > 20: Bus Tie >>

If MN Volts < 20 (do not BUS TIE Pre MECO for 1st FC):

1. (Aff) AC BUS SNSR – OFF
 2. cb AC CONTR (three) – cl
 3. (Aff) INV/AC BUS – OFF (tb-OFF)
 4. (Aff) INV PWR – OFF (tb-OFF)
 5. If MNC(B) dn: CAB FAN A(B) – OFF
 6. Bus Tie
 7. (Aff) INV PWR – ON (tb-ON)
 - ◆ 8. (Aff) INV/AC BUS – ON (tb-ON)
 9. cb AC CONTR (three) – op
 10. GNC I/O RESET
- Post MECO:
11. (Aff) AC BUS SNSR – AUTO TRIP
 12. If pwrdn not reqd: √CAB FAN A(B) – ON

FC SAFING

SM SYS SUMM 1

If FC already SHUTDN:

1. √FC1(2,3) REAC – CL (O2,H2 tb-CL)
 2. FC1(2,3) – START (10 sec or ΔP tb-gray)
 3. FC/MN BUS A(B,C) – ON (tb-ON)
- When FC1(2,3) COOL P decr to < 15 or FC1(2,3) AMPS ≤ 0:
4. FC/MN BUS A(B,C) – OFF (tb-OFF)
- When FC1(2,3) COOL P < 15, then:
5. FC1(2,3) – STOP (ΔP tb-bp or 1 sec) >>

If FC not SHUTDN:

- : 6. MSTR MADDS PWR – OFF
 - : If not already tied:
 - : 7. Perform BUS TIE (Cue Card), then:
 - : If ORB (not deorb prep) kW > 18:
 - : 8. MN BUS TIE (three) – ON (tb-ON)
 - : 9. FC1(2,3) REAC – CL (O2,H2 tb-CL)
 - : If either FC REAC tb still OP:
 - C3 : 10. cb FC1(2,3) REAC VLV CL ENA – cl
 - : 11. FC REAC VLV 1(2,3) – CL
 - : If no joy:
 - R1 : 12. Install sw reten device FC REAC sw
 - : When FC1(2,3) COOL P decr to < 15 or FC1(2,3) AMPS ≤ 0:
 - : 13. ESS BUS SOURCE FC1(2,3) – OFF
 - : 14. FC/MN BUS A(B,C) – OFF (tb-OFF)
 - : When FC1(2,3) COOL P < 15, then:
 - L 15. FC1(2,3) – STOP (ΔP tb-bp or 1 sec)
- Go to LOSS OF 1 FC(2nd FC)(PWRDN), 10-39/10-41/10-45

CRYO O2(H2) PRESS/TEMP HIGH

SM 68 CRYO SYSTEM
SM SYS SUMM 2

1. (Aff) O2(H2) TK HTRS (two) – OFF
2. O2(H2) MANF VLV TK1,TK2 (two) – OP (tb-OP)
3. If PRESS ↑, go to MAL, EPS, 7.6b, CRYO O2(H2) PRES, TK P ↓↑ [1] >>
4. If O2 T ↑, go to MAL, EPS, 7.6l, O2 HTR T [1] >>
5. If H2 T ↑, go to MAL, EPS, 7.6f, H2 HTR T [1]

CRYO O2(H2) LEAK

SM 68 CRYO SYSTEM
SM SYS SUMM 2

If only one TK aff and P/TK P disagree:

1. Go to MAL, EPS, 7.6b, CRYO O2(H2) PRES, TK P ↓↑ [7] >>
2. Reconfig TK HTRS A,B – ON (not AUTO) in TK(s) with P < 740(190)

If all TK Ps in a common manf or the only TK P in an isolated manf < 740(190) and still decr:

3. O2(H2) MANF VLV TK1,TK2 (two) – CL
If either MANF VLV fails to close:
 4. Hold sw in CLOSE posn (install sw reten device if reqd), then:
5. Reconfig TK HTRS A,B – AUTO in TK(s) with incr P
6. Perform aff MN BUS TIE (Cue Card), then:
If O2(H2) TK 1(2) aff (open unaff manf):
 7. O2(H2) MANF VLV TK2(1) – OP
If O2 TK 1(2) aff:
 8. O2 SYS 1(2) SPLY – CL
If O2 TK 1(2) P now incr (PCS leak):
 9. O2 TK1(2) HTRS A,B (two) – AUTO
MANF VLV TK1,TK2 (two) – OP >>
10. Perform aff FC SHUTDN (Cue Card), then:
If aff TK P incr (FC leak):
 11. O2(H2) MANF VLV TK1,TK2 (two) – OP (ASAP if FC3)
 12. (Aff) TK HTRS A,B (two) – AUTO >>

Cont next page

OPCL/ALL/GEN M

BUS TIE
FC SAFING

5-17

CRYO O2(H2)
CRYO SCHEMATIC (5-19)

- If aff TK P not incr within 2 min (MANF or TK leak):
13. (Aff) TK HTRS A,B (two) – OFF
- If TK 1(2) aff and TK P/MANF P diverging (TK leak):
14. O2(H2) MANF VLV TK1,TK2 (two) – OP
 15. Go to MAL, EPS SSR-6, FC RESTART >>
- If TK 3(4,5) aff or if TK P/MANF P tracking (MANF leak) >>
- If any TK P and connected MANF P diverging or $\Delta > 50$:
16. O2(H2) MANF VLV TK1,TK2 (two) – OP
 17. (Aff) TK HTRS A,B (two) – OFF (TK leak or blockage)
 18. (Other) TK HTRS – AUTO >>
- If neither of the above and all TK Ps now steady or incr (small leak or HTR fail):

<p>CAUTION Do not allow P to exceed 920(260)</p>

19. \sqrt{MCC}

CRYO

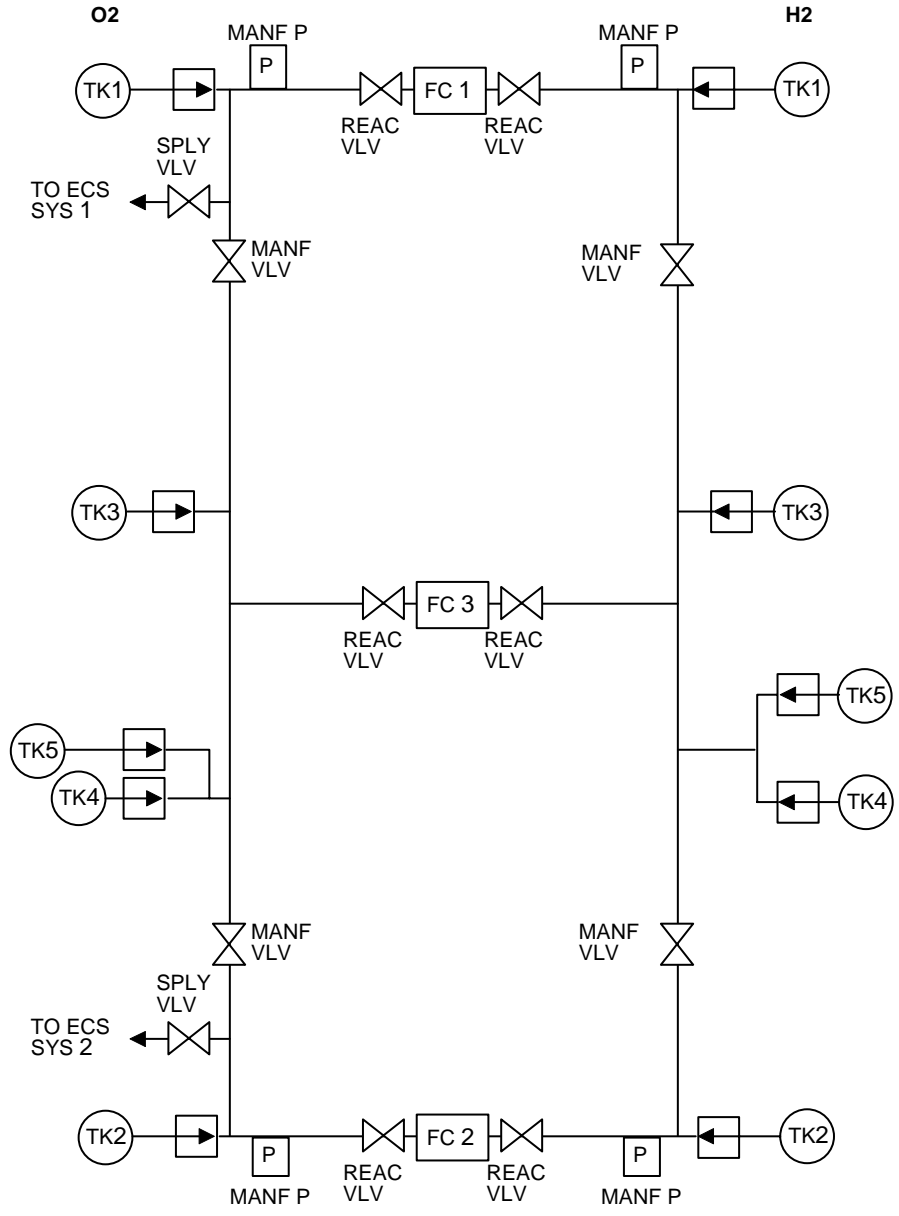

O2/H2 HTR LOSS											
BUS LOSS	PAIRED					PAIRED					
	TK1		TK2		TK3		TK4		TK5		
	A	B	A	B	A	B	A	B	A	B	
MNA DA1	A/M					A/M				A/M	
MNB DA2			AUTO	A/M	AUTO	A/M	AUTO	A/M			
MNC DA3	AUTO	A/M	A/M					A/M		AUTO	A/M
CNTL AB1		MAN			MAN						
		A/M			A/M						
CNTL BC1			MAN					MAN			MAN
			A/M					A/M			A/M
CNTL BC2				MAN							
CNTL BC3											
CNTL CA1	MAN					MAN				MAN	
	A/M					A/M				A/M	
CNTL CA2				A/M							
CNTL CA3											
ESS 1BC	*	*	AUTO	AUTO	*	*	AUTO	AUTO			
	AUTO	AUTO	*	*						AUTO	AUTO
ESS 2CA											
ESS 3AB					AUTO	AUTO	*	*			

* IF TK IS PAIRED WITH A FAILED TK(S), AUTO CAPABILITY IN THIS TK IS LOST. AUTO CAPABILITY IN THIS TK CAN BE REGAINED BY TAKING FAILED TK(S) HTR SWITCHES OUT OF AUTO. TK1 PAIRED WITH TK2, AND TK3 PAIRED WITH TK4.

A/M = AUTO AND MANUAL CAPABILITY LOST

03/27/03

5-20

OPCL/ALL/GEN M

5-21

OPCL/ALL/GEN M

MAIN DC BUS LOSS ID TABLE

BUS INDICATION		MAIN A						MAIN B						MAIN C					
		* FPC1		MPC1		APC4		* FPC2		MPC2		APC5		* FPC3		MPC3		APC6	
		F L C 1	F M C 1	M M C 1	M M C 3	A P C 1	A L C 1	A M C 1	F L C 2	F M C 2	M M C 2	A P C 2	A L C 2	F L C 3	F M C 3	M M C 2	M M C 4	A P C 3	A L C 3
C/W	AC VOLTAGE (AC X Lost)	1						2						3					
	APU TEMP (~2 min if APU X ON & BLR/CNTRLR A sel)					3	3				1	1					2	2	
	(~2 min if APU X ON & BLR/CNTRLR B sel)					1	1				2	2					3	3	
	FREON LOOP (If cooling by FES X only)					B	B										A	A	
	H2O LOOP (If Pump X Active)		1A						1B										
	OMS TVC (During OMS PRI GMBL)					L	L											R	R
	OMS TVC (During OMS SEC GMBL)					R	R					L	L						
RCS JET (When Jet Commanded)		•						•					•						
DISP 67	DC AMPS XY = 0 (X: Fwd,Mid,Aft) (Y: A,B,C)	FA		MA		AA		FB		MB	AB		FC		MC		AC		
	DC V PCA XY = 0 (X: Fwd,Aft) (Y: A,B,C)	FA	FA			AA	AA	FB	FB		AB	AB	FC	FC			AC	AC	
	CNTL BUS RPC X = ** (X: A,B,C)	A						B					C						
PLB LTS	PLB,FLOODS (Fwd,Mid,Aft Port,Stbd,Bkhd,Docking)			FP						FB					MS				
				AS						FS					AP				
S-BAND	SYS X ORB voice & PL PSP msg (X: 1,2)							1					2						
	L2 ATM O2 SYS X SPLY tb - CL			1					2										
P A N E L S	F6/F8 LANDING GEAR X tb - bp (X: L,R,NOSE)							LN					RN						
	F7 CRT X Blanks	1						2					3,4						
	O1 H2O PUMP OUT P X = 20 (Pump Loss)		1A						1B										
	O7 AFT X RCS He P Y tb - bp (X: Both,L,R) (Y: A,B)					BA	BA				RB	RB					LB	LB	
	AFT L,R RCS MANF ISOL 5 tb - bp																•	•	
	O8 FWD RCS He P X tb - bp	A						B											
	FWD RCS TK ISOL X tb - bp (X: 1/2,3/4/5)		3										1						
	FWD RCS MANF ISOL X tb - bp		1						2				5	4					
	R4 HYD BK ISOL VLV X tb - OP					1	1				2	2					3	3	
	LG EXTD ISO VLV tb - OP					•	•												
	R13L RAD CNTL X tb - bp (X: PORT,STBD)			PS	S	P									PS	P	S		
	A8U RMS EE (except DERIGID) tbs - bp, MA LT - ON			•															
A8L X RMS DPY/STO tb - bp (X: PORT,STBD)			P						P					P					
X RMS RETEN LAT tb - bp (X: PORT,STBD)			P	P					P	P				P	P				
PORT RMS R-F-L X tb - bp (X: FWD,MID,AFT)			M	M					F	F				A	A				

* For MNA(B,C) FPC 1(2,3) many other indications are present, most of which are associated with the resultant AC1(2,3) loads. Only the additional indications that positively identify the FPC bus loss are listed.

DATE 07/29/05

MAIN DC BUS LOSS ID TABLE

INDICATION		MAIN A				MAIN B			MAIN C		
		O 1 4	O 1 4 A 8	R 1 4	M L 8 6 B	O 1 5	R 1 4	M L 8 6 B	O 1 6	R 1 4	M L 8 6 B
C/W	CABIN ATM	•				•					
LIGHTS	FLOODS (L Seat,R Seat, CTR Cnsl, MS,OS,PS)			PS		LC	OS		RC	MS	
	Floods (L,R Ovhd Cnsl)	L				R					
	MIDDECK FLOODS X (X: 1,2,3,4,5,6,7,8)				18			26		34 57	
	WMC FLOOD				•						
COMM	All Voice via AUDIO CTR 2									•	
	ATU			MS			MD			PS AL	
	PS,MS,MD,AL										
	UHF SPLX PWR AMP			•							
TIMERS	X MISSION TIMER (X: Fwd,Aft)	F				A					
	X EVENT TIMER (X: Fwd,Aft)	A				F					
P A N E L S	FWD MDUs			MFD2 PLT1			CDR2 MFD1			CDR1 PLT2	
	AFT MDU									AFD1	
	L2 CAB RELIEF X tb - bp					A			B		
	ATM N2 SYS X SPLY, REG INLET tb - bp	1				2					
	O1 CAB dP/dT = 0.45					•					
	CAB PRESS = 0 psia	•									
	PPO2 SNSR X = 0 psia	A				BC					
	O3 RCS/OMS PRPLT QTY Disp Blanks								•		
	R11L SPLY H2O TK X INLET tb - bp				A			B		C	
	SPLY H2O TK X OUTLET tb - bp				B			C		A	
	SPLY H2O DUMP ISOL, B SPLY ISOL VLV tb - bp							•			
	SPLY H2O DUMP, XOVR, GALLEY SPLY VLV tb - bp									•	
	A8U RMS EE (6), SAFING, S/W STOP tb - bp, BRAKES tb - OFF		•								
	ML31C WASTE H2O TK X VLV tb - bp				1						
	WASTE H2O DUMP ISOL VLV tb - bp				•						
SPLY H2O TK D X tb - bp (X: INLET,OUTLET)				O			I				

DATE 12/09/03

5-22

OPCL/ALL/GEN M

ESS DC BUS LOSS ID TABLE

BUS		ESS1BC						ESS2CA					ESS3AB					
		D A 1	FP & LC 1	M P C 1	F D	O 13 R 14	M L 86 B	D A 2	FP & LC 2	M P C 2	F D	O 13 R 14	D A 3	FP & LC 3	M P C 3	F D	O 13	M L 86 B
INDICATION																		
C/W	MA, but no F7 C/W Lts	•				•												
	O2 PRESS						•	•			•	•						•
	H2 PRESS						•	•			•	•						•
	FC REAC			•				•		•		•		•				
	FC PUMP			•	•			•		•	•		•		•	•		
	PRIMARY C/W (Cannot be Reset)							•				•						
	BACKUP C/W (Cannot be Reset)							•				•						
F9 METER	Aff ESS VOLTS OFF Scale Lo	•			•		•			•		•			•			
SM1	Aff DC VOLTS ESS = 0	•					•					•						
COMM	All Voice via AUDIO CTR 1						•				•							
	X ATU,CCU,MIC (X: Cdr,Plt)	C				C		P			P							
LIGHTS LOST	F7 C/W MATRIX	•			•													
	MA BULBS 2 of 4 per MA (except Lamp Test)	•			•		•				•							
	GPC STATUS LTS											•				•		
	X GLARESHIELD FLOOD (X: L,R)	L				L		R			R							
P A N E L S	O2	O2,H2 TK X QTY = 0% (X: 1,2,3,4)	24			2	4	1			1	3					3	
	R1	FC/MN BUS X tb – OFF	A					B				C						
		PL PRI MNC tb – OFF											•					
		INV PWR X tb – OFF (Inv OK)		1					2				3					
		INV/AC BUS X tb – OFF (Bus OK)	1			1		2			2	3				3		
		O2,H2 MANF VLV TK X tb – CL	1		1			2	2			3		3				
		FC X REAC tb – CL	1		1			2	2			3		3	3			
		FC X RDY tb – bp	1		1	1		2	2	2		3		3	3			
		FC X COOL PUMP ΔP tb – bp	1		1	1		2	2	2		3		3	3			
A12	FC3 STRUCT RTN tb – OFF										•							

DATE 05/23/00

5-23

OPCL/ALL/GEN M

BUS LOSS ACTION

**AC1/
MNA**

	<u>PAGE</u>		<u>PAGE</u>
AC1.....	5-26	CNTL AB1.....	5-38
MNA DA1	5-27	AB2.....	5-38
FPC1	5-28	AB3.....	5-38
FLC1	5-28	BC1.....	5-39
FMC1	5-28	BC2.....	5-40
MPC1	5-28	BC3.....	5-40
APC4.....	5-28	CA1.....	5-41
ALC1	5-29	CA2.....	5-41
O14	5-29	CA3.....	5-41
R14.....	5-29	ESS 1BC:	
AC2.....	5-30	DA1 (CIL).....	5-42
MNB DA2	5-31	MPC1 (CIL).....	5-42
FPC2.....	5-32	FD (CIL).....	5-42
FLC2	5-32	O13&R14.....	5-42
FMC2	5-32	ESS 2CA:	
MPC2	5-32	DA2 (CIL).....	5-43
APC5.....	5-33	MPC2 (CIL).....	5-43
ALC2	5-33	FD (CIL).....	5-43
O15	5-33	O13&R14.....	5-43
AC3.....	5-34	ESS 3AB:	
MNC DA3	5-35	DA3 (CIL).....	5-44
FPC3.....	5-36	MPC3 (CIL).....	5-44
FLC3	5-36	FD (CIL).....	5-44
APC6.....	5-36		
ALC3	5-37		
O16	5-37		
R14.....	5-37		

PROBLEM	PWRUP	
	LOW LEVEL (Group B)	MSN EXT (Group C)
EPS BUS LOSS	N/A	ALL FF&FA MDMs

OPCL/ALL/GEN M

BUS LOSS ID (5-21)

5-25

BUS LOSS ACTION

AC1/
MNA

AC1 (2 or 3 Φ s)

- L1
1. Perform FC1 SHUTDOWN (Cue Card), then:
 2. IMU FAN A – OFF
 B(C) – ON
 AV BAY 1 FAN A – OFF
 B – ON
 3 FAN A – ON
 B – OFF
 FREON PUMP LOOP 1 – B
 2 – A
- If MNA FPC1 bus lost, return to MNA FPC1 BUS
LOSS ACTION >>
3. Go to MAL, EPS SSR-110, BUS LOSS: AC1

MNA DA1 (Entire Bus) (Includes AC1)

NOTE

Loss of UHF SPLX Hi Pwr Xmit

- | | | |
|-----|----|--|
| R1 | 1. | Perform <u>FC1 SHUTDN</u> (Cue Card), then: |
| L1 | 2. | PL CAB – MNB |
| | 3. | IMU FAN B(C) – ON |
| | | AV BAY 1 FAN B – ON |
| | | 3 FAN A – ON |
| | | FREON PUMP LOOP 1 – B |
| | | 2 – A |
| | | TOP EVAP HTR DUCT sel – B |
| | | If HI LOAD EVAP ENA: |
| | 4. | HI LOAD DUCT HTR sel – B |
| O6 | 5. | ANNUN BUS SEL ACA 1 – MNB |
| A12 | 6. | APU HTR |
| | | GAS GEN/FU PUMP 1 – B AUTO |
| | | 3 – A AUTO |
| | | TK/FU LN/H2O SYS 1B – AUTO |
| | | 3A – AUTO |
| | 7. | Perform LOSS OF VERNIERS (ORB OPS, <u>RCS</u>), then: |
| | 8. | Go to MAL, <u>EPS</u> SSR-10, BUS LOSS:
MNA DA1 |

MNA FPC1

1. Perform AC1 (2 or 3Φs) (omit MAL, EPS SSR-110, BUS LOSS: AC1), then:
2. Go to MAL, EPS SSR-11, BUS LOSS: MNA FPC1

MNA FLC1

1. GNC 23 RCS
Ovrd F1 MANF STAT – CL
2. Go to MAL, EPS SSR-15, BUS LOSS: MNA FLC1

MNA FMC1

If reqd for att control:

1. GNC 23 RCS
Ovrd F1 MANF STAT – OP
2. Go to MAL, EPS SSR-17, BUS LOSS: MNA FMC1

MNA MPC1

- L1
1. TOP EVAP HTR DUCT sel – B
If HI LOAD EVAP ENA:
 2. HI LOAD DUCT HTR sel – B
- R1
3. PL CAB – MNB
 4. Go to MAL, EPS SSR-12, BUS LOSS: MNA MPC1

MNA APC4

- L1
1. TOP EVAP HTR DUCT sel – B
If HI LOAD EVAP ENA:
 2. HI LOAD DUCT HTR sel – B
- A12
3. APU HTR
GAS GEN/FU PUMP 1 – B AUTO
3 – A AUTO
TK/FU LN/H2O SYS 1B – AUTO
3A – AUTO
 4. Perform LOSS OF VERNIERS (ORB OPS, RCS), then:
 5. Go to MAL, EPS SSR-14, BUS LOSS: MNA APC4

MNA ALC1

- L1 1. TOP EVAP HTR DUCT sel – B
If HI LOAD EVAP ENA:
- A12 2. HI LOAD DUCT HTR sel – B
- 3. APU HTR
 - GAS GEN/FU PUMP 1 – B AUTO
 - 3 – A AUTO
 - TK/FU LN/H2O SYS 1B – AUTO
 - 3A – AUTO
- 4. Perform LOSS OF VERNIERS (ORB OPS, RCS), then:
- 5. Go to MAL, EPS SSR-16, BUS LOSS:
MNA ALC1

**AC2/
MNB**

MNA O14

- O6 1. ANNUN BUS SEL ACA 1 – MNB
- 2. Go to MAL, EPS SSR-23, BUS LOSS:
MNA O14

MNA R14

NOTE

Loss of UHF SPLX Hi Pwr Xmit

Go to MAL, EPS SSR-21, BUS LOSS: MNA R14

AC2/
MNB

AC2 (2 or 3Φs)

- L1
1. Perform FC2 SHUTDN (Cue Card), then:
 2. CAB FAN A – ON
 B – OFF
 IMU FAN A(C) – ON
 B – OFF
 AV BAY 1 FAN A – ON
 B – OFF
 2 FAN A – OFF
 B – ON
 FREON PUMP LOOP 1 – A
 3. SIG CONDR FREON A – AC3
 If MNB FPC2 bus lost, return to MNB FPC2 BUS
 LOSS ACTION >>
 4. Go to MAL, EPS SSR-120, BUS LOSS: AC2
- O17:C

MNB DA2 (Entire Bus) (Includes AC2)

CAUTION
Do not sw S-BD PM CNTL to PNL
if subs Fault Msg – ‘BCE STRG 3
NSP’ or loss of comm

- L1
1. Perform FC2 SHUTDN (Cue Card), then:
 2. CAB FAN A – ON
IMU FAN A(C) – ON
AV BAY 1 FAN A – ON
2 FAN B – ON
FREON PUMP LOOP 1 – A
TOP EVAP HTR DUCT sel – A
- If HI LOAD EVAP ENA:
- O6
3. HI LOAD DUCT HTR sel – A
 4. ANNUN BUS SEL ACA 1 – MNA
2/3 – MNC
- O17:C
A12
5. SIG CONDR FREON A – AC3
 6. APU HTR
GAS GEN/FU PUMP 1 – A AUTO
2 – B AUTO
TK/FU LN/H2O SYS 1A – AUTO
2B – AUTO
- If PL comm reqd:
- A1L
7. S-BD PL PWR SYS – 2
CNTL – PNL,CMD
 8. To reconfig PSP, √MCC
 9. Perform LOSS OF VERNIERS (ORB OPS, RCS), then:
 10. Go to MAL, EPS SSR-30, BUS LOSS:
MNB DA2

MNB FPC2

CAUTION
Do not sw S-BD PM CNTL to PNL
if subs Fault Msg – 'BCE STRG 3
NSP' or loss of comm

- If PL comm reqd:
- A1L 1. S-BD PL PWR SYS – 2
CNTL – PNL,CMD
- If OIU reqd (\sqrt{MCC}):
- SSP 2. OIU PWR – OIU 2 ON (tb-DN)
3. To reconfig PSP/OIU, \sqrt{MCC}
4. Perform AC2 (2 or 3 Φ s) (omit MAL, EPS
SSR-120, BUS LOSS: AC2), then:
5. Go to MAL, EPS SSR-31, BUS LOSS:
MNB FPC2

MNB FLC2

CAUTION
Do not sw S-BD PM CNTL to PNL
if subs Fault Msg – 'BCE STRG 3
NSP' or loss of comm

1. GNC 23 RCS
Ovrd F2 MANF STAT – CL
- If PL comm reqd:
- A1L 2. S-BD PL PWR SYS – 2
CNTL – PNL,CMD
- If OIU reqd (\sqrt{MCC}):
- SSP 3. OIU PWR – OIU 2 ON (tb-DN)
4. To reconfig PSP/OIU, \sqrt{MCC}
5. Go to MAL, EPS SSR-35, BUS LOSS:
MNB FLC2

MNB FMC2

- If reqd for att control:
1. GNC 23 RCS
Ovrd F2 MANF STAT – OP
2. Go to MAL, EPS SSR-37, BUS LOSS:
MNB FMC2

MNB MPC2

- L1 1. TOP EVAP HTR DUCT sel – A
If HI LOAD EVAP ENA:
- A1U 2. HI LOAD DUCT HTR sel – A
3. KU BD PWR – OFF
CNTL – PNL
4. Go to MAL, EPS SSR-32, BUS LOSS:
MNB MPC2

MNB APC5

- L1 1. TOP EVAP HTR DUCT sel – A
If HI LOAD EVAP ENA:
- A12 2. HI LOAD DUCT HTR sel – A
- 3. APU HTR
 - GAS GEN/FU PUMP 1 – A AUTO
 - 2 – B AUTO
 - TK/FU LN/H2O SYS 1A – AUTO
 - 2B – AUTO
- 4. Perform LOSS OF VERNIERS (ORB OPS, RCS), then:
- 5. Go to MAL, EPS SSR-34, BUS LOSS:
MNB APC5

MNB ALC2

- L1 1. TOP EVAP HTR DUCT sel – A
If HI LOAD EVAP ENA:
- A12 2. HI LOAD DUCT HTR sel – A
- 3. APU HTR
 - GAS GEN/FU PUMP 1 – A AUTO
 - 2 – B AUTO
 - TK/FU LN/H2O SYS 1A – AUTO
 - 2B – AUTO
- 4. Perform LOSS OF VERNIERS (ORB OPS, RCS), then:
- 5. Go to MAL, EPS SSR-36, BUS LOSS:
MNB ALC2

**AC3/
MNC**

MNB O15

- O6 1. ANNUN BUS SEL ACA 1 – MNA
2/3 – MNC
- 2. Go to MAL, EPS SSR-45, BUS LOSS:
MNB O15

AC3 (2 or 3Φs)

**AC3/
MNC**

- L1 1. Perform FC3 SHUTDN (Cue Card), then:
- 2. CAB FAN A – OFF
 B – ON
 IMU FAN B(A) – ON
 C – OFF
- L4:F cb AC1 H2O LOOP PUMP 1A/2 (three) – cl
 H2O PUMP LOOP 1 – ON
 2 – GPC
 AV BAY 2 FAN A – ON
 B – OFF
 3 FAN A – OFF
 B – ON
 FREON PUMP LOOP 2 – B
- O17:C 3. SIG CONDR FREON B – AC2
 If MNC FPC3 bus lost, return to MNC FPC3 BUS
 LOSS ACTION >>
- 4. Go to MAL, EPS SSR-130, BUS LOSS: AC3

MNC DA3 (Entire Bus) (Includes AC3)

- | | | |
|----|----|---|
| L1 | 1. | Perform <u>FC3 SHUTDN</u> (Cue Card), then: |
| | 2. | CAB FAN B – ON
IMU FAN B(A) – ON
H2O PUMP LOOP 1 – ON
AV BAY 2 FAN A – ON
3 FAN B – ON
FREON PUMP LOOP 2 – B
FLASH EVAP CNTLR PRI A – OFF
B – ON |
| C3 | 3. | S-BD PM CNTL – PNL,CMD |

NOTE

If S-BD mode TDRS or STDN HI, xmit may be delayed 140 sec for PA warmup. Receive not affected

- | | | |
|-------|----|--|
| O6 | 4. | AUD CTR – 1 |
| O17:C | 5. | ANNUN BUS SEL ACA 2/3 – MNB |
| A12 | 6. | SIG CONDR FREON B – AC2 |
| | 7. | APU HTR
GAS GEN/FU PUMP 2 – A AUTO
3 – B AUTO
TK/FU LN/H2O SYS 2A – AUTO
3B – AUTO |
| | 8. | Perform LOSS OF VERNIERS (ORB OPS, <u>RCS</u>), then: |
| | 9. | Go to MAL, <u>EPS SSR-50</u> , BUS LOSS:
MNC DA3 |

MNC FPC3

- C3 1. S-BD PM CNTL – PNL,CMD

NOTE

If S-BD mode TDRS or STDN HI, xmit
may be delayed 140 sec for PA warmup.
Receive not affected

2. Perform AC3 (2 or 3 Φ s) (omit MAL, EPS
SSR-130, BUS LOSS: AC3), then:
3. Perform LOSS OF VERNIERS (ORB OPS,
RCS), then:
4. Go to MAL, EPS SSR-51, BUS LOSS:
MNC FPC3

MNC FLC3

- C3 1. S-BD PM CNTL – PNL,CMD

NOTE

If S-BD mode TDRS or STDN HI, xmit
may be delayed 140 sec for PA warmup.
Receive not affected

2. GNC 23 RCS
Ovrđ F4 MANF STAT – CL
3. Perform LOSS OF VERNIERS (ORB OPS,
RCS), then:
4. Go to MAL, EPS SSR-55, BUS LOSS:
MNC FLC3

MNC APC6

- L1 1. FLASH EVAP CNTLR PRI A – OFF
B – ON

- A12 2. APU HTR
GAS GEN/FU PUMP 2 – A AUTO
3 – B AUTO
TK/FU LN/H2O SYS 2A – AUTO
3B – AUTO
3. Go to MAL, EPS SSR-54, BUS LOSS:
MNC APC6

MNC ALC3

- L1 1. FLASH EVAP CNTLR PRI A – OFF
B – ON
- A12 2. APU HTR
GAS GEN/FU PUMP 2 – A AUTO
3 – B AUTO
TK/FU LN/H2O SYS 2A – AUTO
3B – AUTO
- 3. Go to MAL, EPS SSR-56, BUS LOSS:
MNC ALC3

MNC O16

- O6 1. ANNUN BUS SEL ACA 2/3 – MNB
- 2. Go to MAL, EPS SSR-63, BUS LOSS:
MNC O16

MNC R14

- C3 1. AUD CTR – 1
- 2. Go to MAL, EPS SSR-61, BUS LOSS:
MNC R14

CNTL

CNTL

CNTL AB1

- L1 1. TOP EVAP HTR DUCT sel – B
If HI LOAD EVAP ENA:
- A12 2. HI LOAD DUCT HTR sel – B
3. APU HTR
GAS GEN/FU PUMP 1 – B AUTO
3 – A AUTO
TK/FU LN/H2O SYS 1B – AUTO
3A – AUTO
- If AB1,2,3 unpwr:
4. GNC 23 RCS
Ovrd F1 MANF STAT – CL
5. Go to MAL, EPS SSR-100, BUS LOSS:
CNTLAB1

CNTL AB2

- L1 1. TOP EVAP HTR DUCT sel – B
If HI LOAD EVAP ENA:
- A12 2. HI LOAD DUCT HTR sel – B
3. GNC 23 RCS
Ovrd F1 MANF STAT – CL
4. APU HTR
GAS GEN/FU PUMP 1 – B AUTO
TK/FU LN/H2O SYS 1B – AUTO
3A – AUTO
5. Go to MAL, EPS SSR-101, BUS LOSS:
CNTLAB2

CNTL AB3

NOTE

CDR's BFS engage capability lost

- L1 1. TOP EVAP HTR DUCT sel – B
If HI LOAD EVAP ENA:
2. HI LOAD DUCT HTR sel – B
Do not perform next step if AB1,2,3 unpwr:
If reqd for att control:
- A12 3. GNC 23 RCS
Ovrd F1 MANF STAT – OP
4. APU HTR
GAS GEN/FU PUMP 1 – A AUTO
TK/FU LN/H2O SYS 1B – AUTO
3A – AUTO

Cont next page

- A6U If DAP MAN MODE reqd:
 5. Use aft station
 If BFS engage reqd:
 6. Use PLT's RHC
- O6 GPC MODE 1,2,4 (three) – STBY,HALT
 BFS I/O RESET
7. Go to MAL, EPS SSR-102, BUS LOSS:
 CNTLAB3

CNTL BC1

CAUTION
 Do not sw S-BD PM CNTL to PNL
 if subs Fault Msg – 'BCE STRG 3
 NSP' or loss of comm

- L1 1. TOP EVAP HTR NOZ L – B AUTO
 DUCT sel – A
 If HI LOAD EVAP ENA:
 2. HI LOAD DUCT HTR sel – A
- A12 3. APU HTR
 GAS GEN/FU PUMP 1 – A AUTO
 2 – B AUTO
 TK/FU LN/H2O SYS 1A – AUTO
 2B – AUTO
- If PL comm reqd:
 A1L 4. S-BD PL PWR SYS – 2
 CNTL – PNL,CMD
- If OIU reqd (√MCC):
 SSP 5. OIU PWR – OIU 2 ON (tb-DN)
 6. To reconfig PSP/OIU, √MCC
- If BC1,2,3 unpwr:
 7. GNC 23 RCS
 Ovrđ F2 MANF STAT – CL
8. Perform LOSS OF VERNIERS (ORB OPS,
RCS), then:
 9. Go to MAL, EPS SSR-103, BUS LOSS:
 CNTLBC1

CNTL BC2

- L1 1. TOP EVAP HTR DUCT sel – A
If HI LOAD EVAP ENA:
2. HI LOAD DUCT HTR sel – A
- C3 3. S-BD PM CNTL – PNL,CMD

NOTE

If S-BD mode TDRS or STDN HI, xmit
may be delayed 140 sec for PA warmup.
Receive not affected

- A12 4. GNC 23 RCS
Ovrđ F2 MANF STAT – CL
- A12 5. APU HTR
GAS GEN/FU PUMP 2 – B AUTO
TK/FU LN/H2O SYS 1A – AUTO
2B – AUTO
- C3 6. If DAP MAN MODE reqđ: Use fwd station
7. Perform LOSS OF VERNIERS (ORB OPS,
RCS), then:
8. Go to MAL, EPS SSR-104, BUS LOSS:
CNTLBC2

CNTL BC3

- L1 1. TOP EVAP HTR NOZ R – B AUTO
DUCT sel – A
If HI LOAD EVAP ENA:
2. HI LOAD DUCT HTR sel – A
If reqđ for att control:
Do not perform next step if BC1,2,3 unpwrđ:
3. GNC 23 RCS
Ovrđ F2 MANF STAT – OP
- A12 4. APU HTR
GAS GEN/FU PUMP 2 – A AUTO
TK/FU LN/H2O SYS 1A – AUTO
2B – AUTO
- A6 5. If DAP MAN MODE reqđ: Use aft station
6. Go to MAL, EPS SSR-105, BUS LOSS:
CNTLBC3

CNTL CA1

NOTE

GPC 3,5 – no BFS engage capability. √MCC for possible move of BFS FUNCTION

- A12
1. APU HTR
GAS GEN/FU PUMP 2 – A AUTO
3 – B AUTO
TK/FU LN/H2O SYS 2A – AUTO
3B – AUTO
- If CA1,2,3 unpwr:
2. **GNC 23 RCS**
Ovrd F3 MANF STAT – CL
 3. Go to MAL, EPS SSR-106, BUS LOSS:
CNTLCA1

CNTL CA2

- L1
1. FLASH EVAP CNTLR PRI A – OFF
B – ON
 2. **GNC 23 RCS**
Ovrd F3 MANF STAT – CL
- A12
3. APU HTR
GAS GEN/FU PUMP 3 – B AUTO
TK/FU LN/H2O SYS 2A – AUTO
3B – AUTO
- C3
4. If DAP MAN MODE reqd: Use fwd station
 5. Go to MAL, EPS SSR-107, BUS LOSS:
CNTLCA2

ESS

CNTL CA3

- A12
1. APU HTR
GAS GEN/FU PUMP 3 – A AUTO
TK/FU LN/H2O SYS 2A – AUTO
3B – AUTO
 2. Go to MAL, EPS SSR-108, BUS LOSS:
CNTLCA3

ESS 1BC DA1 (Entire Bus)

NOTE

Pri C/W Sys & Matrix lost (B/U C/W Tone remains). GPC 1,4 lost if pwr cycled OFF or ON

1. Perform FC1 SHUTDOWN (Cue Card), then:
If calling proc complete:
2. Go to MAL, EPS SSR-70, BUS LOSS:
ESS1BC DA1

ESS 1BC MPC1

1. Perform FC1 SHUTDOWN (Cue Card), then:
2. Go to MAL, EPS SSR-72, BUS LOSS:
ESS1BC MPC1

ESS 1BC FD

NOTE

GPC 1,4 lost if pwr cycled OFF or ON

1. Perform FC1 SHUTDOWN (Cue Card), then:
2. Go to MAL, EPS SSR-74, BUS LOSS:
ESS1BC FD

ESS 1BC O13&R14

NOTE

Pri C/W Sys & Matrix lost (B/U C/W Tone remains)

- Go to MAL, EPS SSR-75, BUS LOSS:
ESS1BC O13&R14

ESS

ESS 2CA DA2 (Entire Bus)

NOTE

C/W B PWR SPLY lost (Pri C/W remains). FAULT SUMM MSGs must be reset to avoid C/W Tone masking.
GPC 2,5 lost if pwr cycled OFF or ON

- C3
1. AUD CTR – 2
 2. Perform FC2 SHUTDN (Cue Card), then:
If calling proc complete:
 3. Go to MAL, EPS SSR-80, BUS LOSS:
ESS2CA DA2

ESS 2CA MPC2

1. Perform FC2 SHUTDN (Cue Card), then:
2. Go to MAL, EPS SSR-82, BUS LOSS:
ESS2CA MPC2

ESS 2CA FD

NOTE

GPC 2,5 lost if pwr cycled OFF or ON

1. Perform FC2 SHUTDN (Cue Card), then:
2. Go to MAL, EPS SSR-83, BUS LOSS:
ESS2CA FD

ESS 2CA O13&R14

NOTE

C/W B PWR SPLY lost (Pri C/W remains). FAULT SUMM MSGs must be reset to avoid C/W Tone masking

- C3
1. AUD CTR – 2
 2. Go to MAL, EPS SSR-84, BUS LOSS:
ESS2CA O13&R14

ESS 3AB DA3 (Entire Bus)

NOTE

Do not engage BFS. Computer
Status Matrix lost. GPC 3 lost if
pwr cycled OFF or ON

1. Perform FC3 SHUTDOWN (Cue Card), then:
If calling proc complete:
2. Go to MAL, EPS SSR-90, BUS LOSS:
ESS3AB DA3

ESS 3AB MPC3

1. Perform FC3 SHUTDOWN (Cue Card), then:
2. Go to MAL, EPS SSR-92, BUS LOSS:
ESS3AB MPC3

ESS 3AB FD

NOTE

Do not engage BFS. GPC 3 lost if
pwr cycled OFF or ON

1. Perform FC3 SHUTDOWN (Cue Card), then:
2. Go to MAL, EPS SSR-93, BUS LOSS:
ESS3AB FD

GUIDANCE, NAVIGATION, AND CONTROL

GNC

OV103,104

A6-1

OPCL/ALL/GEN M

GPS TROUBLESHOOTING

1. VERIFY GPS FUNCTIONING PROPERLY

CRT GNC 55 GPS STATUS
√STAT = BLANK or BATT
√MODE = INS
√DG FAIL = BLANK
√QA1 P $1\sigma \leq 175$ (can be > 175 for no more than 5 min)
√LAST SEL FIL UPDATE < 5 min

If GPS functioning properly for 10 min, √MCC >>
(if no comm, go to GPS INCORPORATION (ORBIT
OPS, GNC)) >>

2. GPS TROUBLESHOOTING

√GPS TO NAV INH – ITEM 36 EXEC (*)

A13 A. GPS sw Config
√GPS PWR – ON
If OV103:
√GPS PRE AMPL (two) – MNC
If OV104:
√GPS PRE AMPL (two) – ON

A13 * If receiver not pwr'd: *
* GPS PRE AMPL (two) – MNC (OV103) *
* – ON (OV104) *
* GPS PWR – ON *
* √GPS ENCRYPT – NORM *
* Wait at least 30 sec *
CRT * GNC I/O RESET *
* *
* GNC 55 GPS STATUS *
* √NAV – ITEM 18 (*) *
* INIT – ITEM 15 EXEC (*) *
* √MODE – INIT *
* NAV – ITEM 18 EXEC (*) *
* √MODE – INS *

CRT B. GPS Filter Restart
√MODE – INS
If not in INS MODE, go to GPS INIT, step C,
next page
RESTART – ITEM 21 EXEC (*)
Wait 5 sec
√RESTART – ITEM 21 (no *)

Cont next page

NOTE

GPS may take up to 1 min for steady state performance

Repeat step 1. If GPS not functioning properly within 1 min, perform step C below

- CRT C. GPS INIT
 INIT – ITEM 15 EXEC (*)
 √MODE – INIT
 NAV – ITEM 18 EXEC (*)
 √MODE – INS

NOTE

GPS may take up to 5 min for steady state performance

Repeat step 1. If GPS not functioning properly within 5 min, perform step D below

- A13 D. GPS Long Pwr Cycle
 GPS PWR – OFF (at least 30 sec),ON
 (expect 'BCE STRG 2 GPS' msg)
 Wait at least 30 sec
CRT GNC I/O RESET
 √NAV – ITEM 18 (*)
 INIT – ITEM 15 EXEC (*)
 √MODE – INIT
 NAV – ITEM 18 EXEC (*)
 √MODE – INS

NOTE

May take up to 12 min to acquire 4 or more satellites

Check SATELLITES – tracking at least 4 satellites

Repeat step 1. If GPS not functioning properly within 12 min, perform step E next page

Cont next page

OV103,104

A6-3

OPCL/3,4/GEN M,5

A13
CRT

E. GPS S/TEST
GPS PRE AMPL (two) – OFF
√NAV – ITEM 18 (*)
S/TEST – ITEM 12 EXEC (*)
√'BIT' in STAT field after ~6 sec
Wait for 'BIT' to clear after ~2 min
√S/TEST '↑'; if '↓', go to GPS SAFING (step 3)

A13
CRT

GPS PRE AMPL (two) – MNC (OV103)
– ON (OV104)
NAV – ITEM 18 EXEC (*)
√MODE – INS

Repeat step 1. If GPS not functioning properly,
perform step 3 below

3. GPS SAFING

CRT

GNC 55 GPS STATUS
√GPS TO G&C INH – ITEM 33 EXEC (*)
√GPS TO NAV INH – ITEM 36 EXEC (*)

OV103,104

A6-4

OPCL/3,4/GEN M,5

GUIDANCE, NAVIGATION, AND CONTROL

GNC

OV105

OPCL/ALL/GEN M

B6-1

NOTE

GPS may take up to 1 min for steady state performance

Repeat step 1. If GPS not functioning properly within 1 min, perform step C, next page

- CRT C. GPS INIT
 INIT – ITEM 14(15,16) EXEC (*)
 √MODE – INIT
 NAV – ITEM 17(18,19) EXEC (*)
 √MODE – INS

NOTE

GPS may take up to 5 min for steady state performance

Repeat step 1. If GPS not functioning properly within 5 min, perform step D below

- O7 D. GPS Long Pwr Cycle
 GPS 1(2,3) PWR – OFF (at least 30 sec), ON
 (expect 'BCE STRG X GPS' msg)
 Wait at least 30 sec
CRT GNC I/O RESET
 √NAV – ITEM 17(18,19) (*)
 INIT – ITEM 14(15,16) EXEC (*)
 √MODE – INIT
 NAV – ITEM 17(18,19) EXEC (*)
 √MODE – INS

NOTE

May take up to 12 min to acquire 4 or more satellites

Check SATELLITES – tracking at least 4 satellites

Repeat step 1. If GPS not functioning properly within 12 min, perform step E

Cont next page

B6-3

OV105

OPCL/5/GEN M,5

O7
CRT

E. GPS S/TEST
GPS 1(2,3) PRE AMPL (two) – OFF
√NAV – ITEM 17(18,19) (*)
S/TEST – ITEM 11(12,13) EXEC (*)
√'BIT' in STAT field after ~6 sec
Wait for 'BIT' to clear after ~2 min
√S/TEST '↑'; if '↓', go to GPS CLEANUP (step 3)

O7
CRT

GPS 1(2,3) PRE AMPL (two) – ON
NAV – ITEM 17(18,19) EXEC (*)
√MODE – INS

Repeat step 1. If GPS not functioning properly,
perform step 3, next page

3. GPS CLEANUP
If GPS functioning properly, on MCC GO, reset affected
GPS

CRT

GNC 55 GPS STATUS
DES RCVR 1(2,3) – ITEM 26(27,28) EXEC (no *)

If no GPS functioning properly:
√GPS TO G&C INH – ITEM 33 EXEC (*)
√GPS TO NAV INH – ITEM 36 EXEC (*)

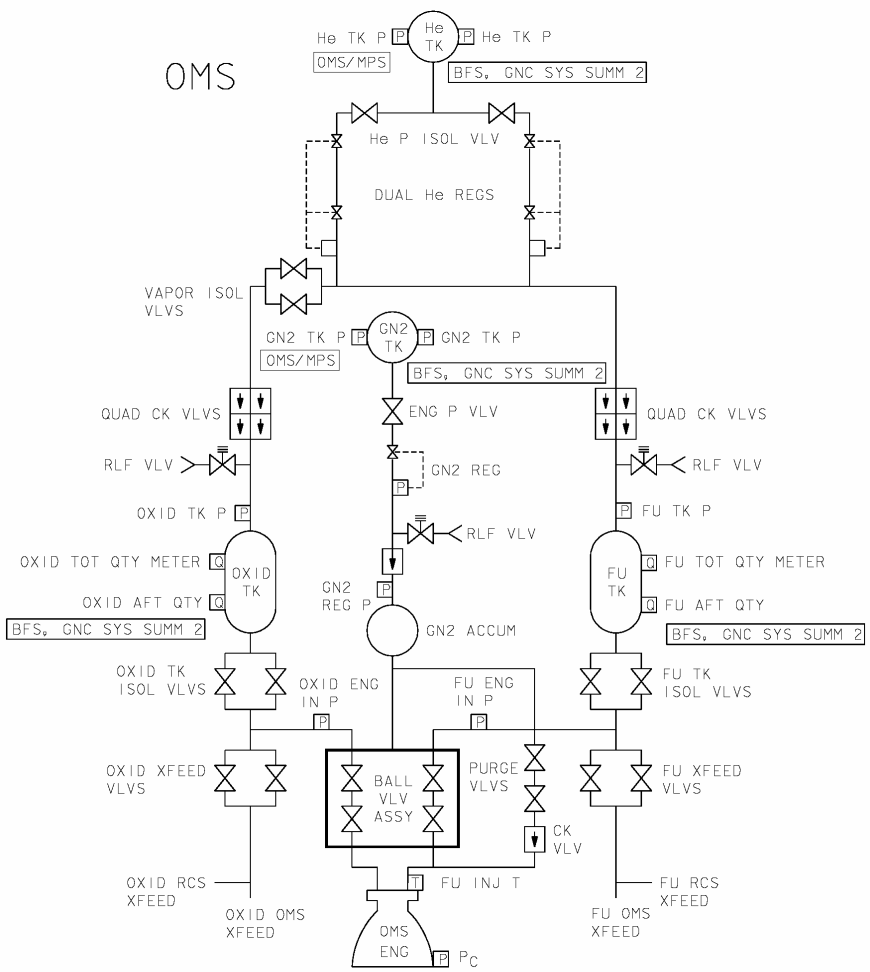

DATE 06/17/98

48033A701.SCH 1

OMS

OMS SECURE

1. OMS ENG (two) – OFF
If OMS XFEED config:
2. (Receiving) OMS XFEED (two) – CL (tb-CL)
3. (Aff) OMS XFEED (two) – CL (tb-CL)
TK ISOL (two) – CL (tb-CL)
He PRESS/VAP ISOL (two) – CL

OMS TK P (FU and OX) HIGH

GNC SYS SUMM 2

1. √(Aff) OMS He PRESS/VAP ISOL (two) – CL
2. L(R) OMS DUAL He REG failed open

XFEED: R OMS to L OMS

GNC 23 RCS

NOTE

Proc only to be used preburn

1. DAP: FREE
2. √L,R OMS XFEED (four) – CL (tb-CL)
3. RCS TK ISOL (six) – CL (tb-CL)
XFEED (four) – OP (tb-OP)
4. If RCS MANF P (OX and FU) > 130, continue; otherwise, √MCC >>
5. √R OMS TK ISOL (two) – OP (tb-OP)
L OMS TK ISOL (two) – CL (tb-CL)
L,R OMS XFEED B (two) – OP (tb-OP)
6. RCS XFEED (four) – CL (tb-CL)
TK ISOL (six) – OP (tb-OP)
7. DAP: as reqd

XFEED: L OMS to R OMS

GNC 23 RCS

NOTE

Proc only to be used preburn

1. DAP: FREE
2. √L,R OMS XFEED (four) – CL (tb-CL)
3. RCS TK ISOL (six) – CL (tb-CL)
XFEED (four) – OP (tb-OP)
4. If RCS MANF P (OX and FU) > 130, continue; otherwise, √MCC >>
5. √L OMS TK ISOL (two) – OP (tb-OP)
R OMS TK ISOL (two) – CL (tb-CL)
L,R OMS XFEED B (two) – OP (tb-OP)
6. RCS XFEED (four) – CL (tb-CL)
TK ISOL (six) – OP (tb-OP)
7. DAP: as reqd

OMS

XFEED RETURN: OMS

L,R OMS XFEED (four) – CL (tb-CL)
TK ISOL (four) – OP (tb-OP)

OMS N2 TK P LOW

GNC SYS SUMM 2

1. $\sqrt{N2}$ TK P < 1200 or decr ([OMS/MPS] and SPEC)
If [OMS/MPS] and SPEC disagree (inst prob):
| 2. Go to MAL, OMS, 11.1a, L(R) OMS TK P [1] >>
If [OMS/MPS] and SPEC agree:
 3. $\sqrt{(Aff)}$ OMS ENG – OFF
 4. Go to MAL, OMS, 11.1a, L(R) OMS TK P [4]

OMS N2 REG P LOW

GNC SYS SUMM 2

1. \sqrt{OMS} ENG (two) – OFF
2. Go to MAL, OMS, 11.1a, L(R) OMS TK P [10]

OMS N2 REG P HIGH

GNC SYS SUMM 2

1. \sqrt{OMS} ENG (two) – OFF
2. Go to MAL, OMS, 11.1a, L(R) OMS TK P [21]

OPCL/ALL/GEN M

**OMS SECURE/TK P HI
XFEED: R OMS/L OMS**

7-3

**XFEED RETURN
OMS N2 TK/REG P**

OMS TK P (FU or OX) LOW

GNC SYS SUMM 2

1. Check with corresp ENG IN P

If ENG IN P disagrees:

2. Go to MAL, OMS, 11.1a, L(R) OMS TK P [29] >>

If aff OMS feeding OMS/RCS I'CNCT:

If both OX and FU TK P LOW:

3. (Aff) OMS He PRESS/VAP ISOL A – OP

Wait 10 sec

OMS He PRESS/VAP ISOL A – CL

4. If TK P incr >>

5. If TK P not incr:

(Aff) OMS He PRESS/VAP ISOL B – OP

Wait 10 sec

OMS He PRESS/VAP ISOL B – CL

If TK P incr:

6. Go to step 8

If TK P still not incr:

7. Perform I'CNCT RETURN (RCS), 8-4, then:

8. Go to MAL, OMS, 11.1a, L(R) OMS TK P [22] >>

If OX or FU (not both) TK P LOW:

: Secure RCS and OMS:

: 9. DAP: FREE

: 10. L,R RCS MANF ISOL (ten) – CL (tb-CL)

: XFEED (four) – CL (tb-CL)

: 11. (Aff) OMS XFEED (two) – CL (tb-CL)

: TK ISOL (two) – CL (tb-CL)

L He PRESS/VAP ISOL (two) – CL

√SINGLE MANF (√MANF P)

12. If leak found: Return to desired config except leave aff

MANF closed >>

√TK LEG (√TWO MANF P)

13. If leak found: Return to desired config except leave TK
ISOL (1/2 or 3/4/5), MANFs, and corresp XFEED vlvs
closed

14. If MANF 3/4/5 Leg leak: Go to LOSS OF VERNIERS
(ORB OPS, RCS) >>

Cont next page

√OMS TK and OMS INLET LINE (√OMS TK P and OMS IN P)

If leak found:

15. √L,R RCS He PRESS A(B) (two) – GPC (tb-OP)
B(A) (two) – CL (tb-CL)
TK ISOL (six) – OP (tb-OP)
MANF ISOL (ten) – OP (tb-OP), GPC
16. GNC 23 RCS
OMS PRESS ENA OFF – ITEM 7 EXEC
17. DAP: as reqd
18. If OMS PRPLT TK P decr:
| Go to LEAKING OMS PRPLT/He BURN >>
19. If OMS IN P decr >>

√XFEED LINES

20. GNC 23 RCS
RCS L – ITEM 2 EXEC

If XFEED P decr or zero:

21. √L,R RCS He PRESS A(B) (two) – GPC (tb-OP)
B(A) (two) – CL (tb-CL)
TK ISOL (six) – OP (tb-OP)
MANF ISOL (ten) – OP (tb-OP), GPC
22. GNC 23 RCS
OMS PRESS ENA OFF – ITEM 7 EXEC
23. DAP: as reqd
24. Do not XFEED/I'CNCT >>

If leak not found:

25. √L,R RCS He PRESS A(B) (two) – GPC (tb-OP)
B(A) (two) – CL (tb-CL)
TK ISOL (six) – OP (tb-OP)
MANF ISOL 1,2,3,4 (eight) – OP (tb-OP), GPC
26. GNC 23 RCS
OMS PRESS ENA OFF – ITEM 7 EXEC
27. DAP: as reqd, PRI(ALT) only
28. Go to MAL, OMS, 11.1a, L(R) OMS TK P 36 >>

If aff OMS not feeding OMS/RCS I'CNCT:

29. Perform OMS SECURE, then:
30. If OMS PRPLT TK P decr:
Go to LEAKING OMS PRPLT/He BURN >>
31. If either OMS IN P decr >>

If leak not found:

32. Go to MAL, OMS, 11.1a, L(R) OMS TK P 47

OPCL/ALL/GEN M

OMS TK P (FU or OX) LOW 7-5

OMS He TK P LOW

GNC SYS SUMM 2

1. $\sqrt{\text{He TK P}} < 1500$ or decr abnormal (OMS/MPS and SPEC)

If OMS/MPS and SPEC disagree (inst prob):

2. Go to MAL, OMS, 11.1a, L(R) OMS TK P 63 >>

3. $\sqrt{\text{OMS He PRESS/VAP ISOL (two) - CL}}$

If He TK P still decr:

4. (Aff) OMS He PRESS/VAP ISOL (two) – OP

5. If not at max blowdown (QTY > 39%):

Go to LEAKING OMS PRPLT/He BURN >>

6. If l'cnct: Perform l'CNCT RETURN (RCS), 8-4, then:

If OMS TK P FU/OX decr:

7. Go to OMS TK P (FU or OX) LOW >>

If neither decr (He leg leak):

8. $\sqrt{\text{MCC}}$ for OMS Burn deltas

LEAKING OMS PRPLT/He BURN

1. Install LEAKING OMS PRPLT/He BURN (Cue Card) and ON-ORBIT OMS BURN MONITOR (Cue Card) (C2 wedge)
 2. GNC 55 GPS STATUS
√GPS TO NAV – INH (*)
 3. If MM106: PASS, OPS 301 PRO
BFS, OPS 301 PRO
 4. GNC, OPS 202(302) PRO
 5. GNC XXXXX MNVR EXEC leaking OMS – sel, and determine out-of-plane or retrograde burn based on TIG (MCC or msg)
 6. Enter PEG 7 TARGET data:
 - If out-of-plane:
 - Enter ΔVX and $\Delta VZ = 0.0$
 - For PRPLT LK, enter $\Delta VY \pm 500$
 - For He LK, enter $\pm \Delta VY$ from LEAKING OMS He ΔV TABLE
 - If retrograde:
 - Enter ΔVY and $\Delta VZ = 0.0$
 - For PRPLT LK, enter $-\Delta VX$ from ΔVX vs ORB ALT chart
 - For He LK, enter $-\Delta VX$ from LEAKING OMS He ΔV TABLE, steps 1-4
 7. Load TARGET DATA:
 - LOAD – ITEM 22 EXEC (if retrograde burn, $\sqrt{TGT HP = 95 \pm 1}$; adjust ΔVX as reqd)
 - TIMER – ITEM 23 EXEC
- If OPS 2:
8. √Pri RJD LOGIC, DRIVER (sixteen) – ON
√cb L,R DDU (four) – cl
DAP: B/AUTO/PRI
DAP TRANS: NORM/PULSE/PULSE
- If OPS 3:
9. GNC 23 RCS
 - L1A or L3A – desel (N/A He leak)
 - R1A or R3A – desel (N/A He leak)
10. Mnvr to burn att. When mnvr complete, update TIG if appropriate
 11. GMBL CK sel sys

Cont next page

OPCL/ALL/GEN M

OMS He TK P LOW
 ΔVX vs ORB ALT (7-9)

LK PRPLT/He BURN
7-7 LK OMS He ΔV TABLE (7-10)

At TIG-4, perform OMS burn prep:

12. (Leaking) OMS TK ISOL (two) – OP (tb-OP)
√XFEED (four) – CL (tb-CL)
He PRESS/VAP ISOL A – OP (wait 2 sec),
B – OP
13. Perform burn using LEAKING OMS PRPLT/He BURN (Cue Card),
then postburn:
If OPS 3:
 14. GNC 23 RCS
AFT jets – reset (N/A He leak)
 15. FLT CNTLR PWR (two) – OFF
cb L,R DDU (four) – as reqd
 16. (Aff) OMS He PRESS/VAP ISOL (two) – CL
TK ISOL (two) – CL (tb-CL)
 17. DAP: INRTL
 18. If OPS 2: DAP TRANS: PULSE/PULSE/PULSE
| GNC, OPS 201 PRO
If MM 302: GNC, OPS 301 PRO
 19. DAP – as reqd

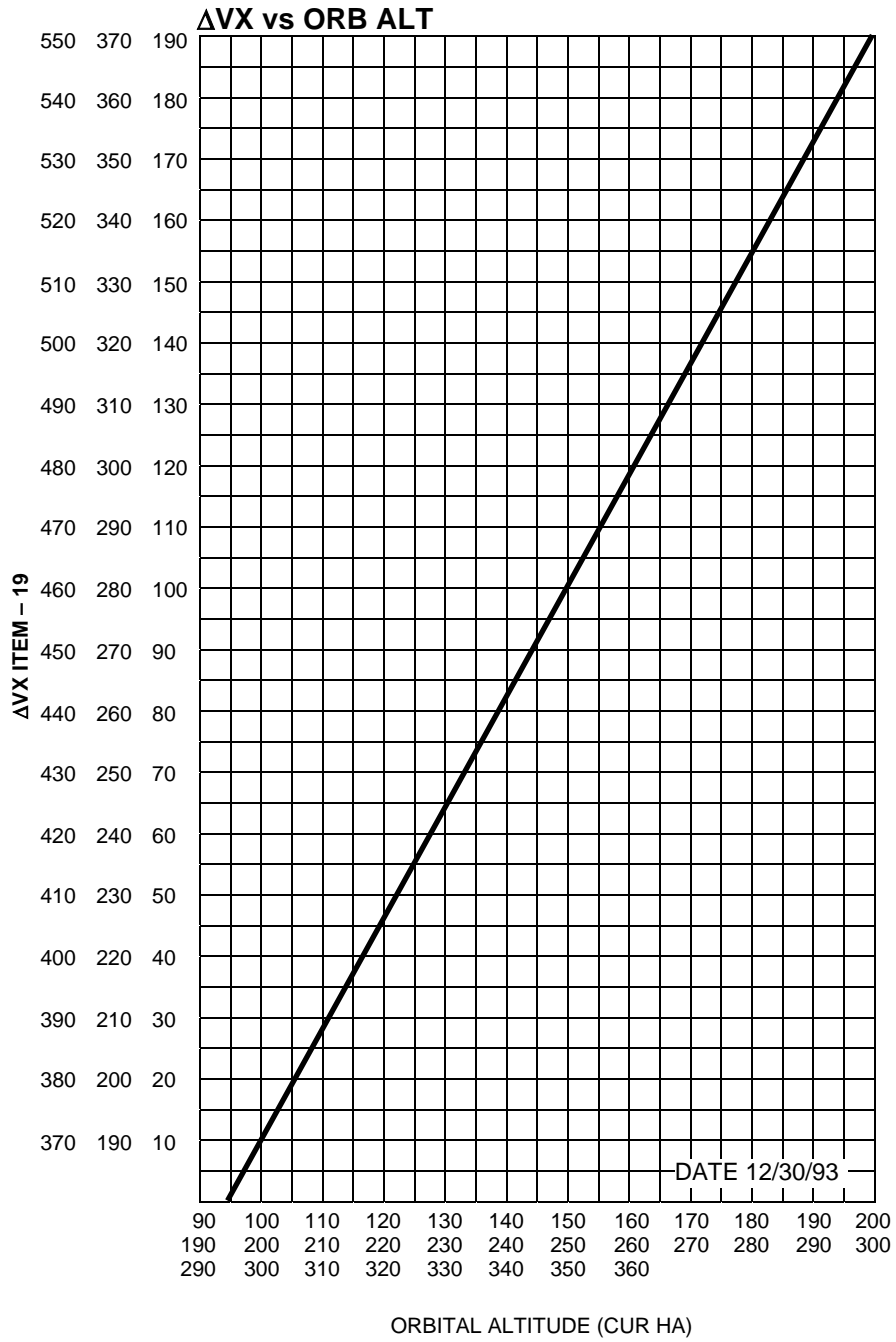

LEAKING OMS He ΔV TABLE

1. Pick ΔV from table to achieve MAX BLOWDOWN

Affected OMS % (QTY)	ΔV
95	352
90	320
85	289
80	257
75	226
70	195
65	164
60	133
55	102
50	71
45	40
40	10

If retrograde burn:

2. Verify ΔVX vs ORB ALT
- If ΔV from table < ΔVX from chart:
3. Use ΔV from table (Hp will be above 95 nm) >>
- If ΔV from table > ΔVX from chart:
4. Use ΔVX from chart to take Hp to 95 nm, then repeat proc to burn out-of-plane to achieve max blowdown (39%)

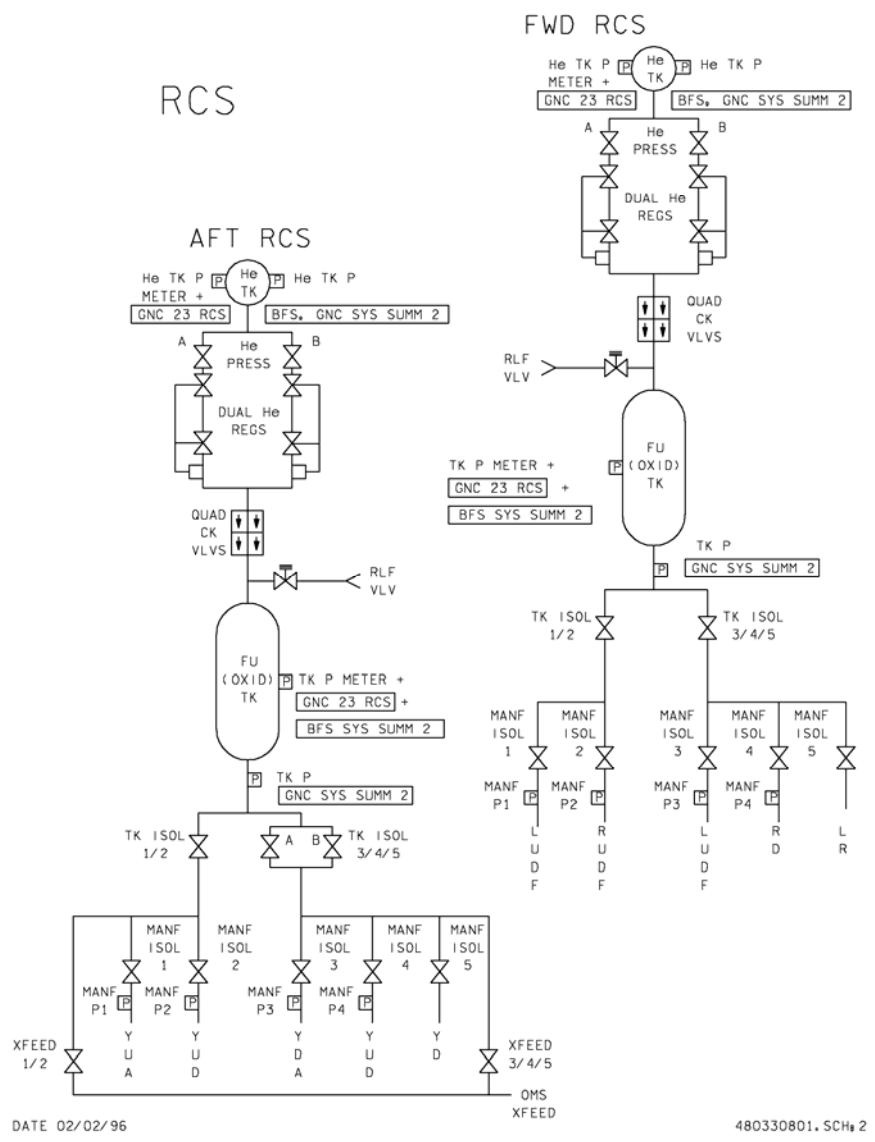

RCS

RCS SECURE (FWD,AFT)

If normal config:

1. RCS MANF ISOL (five) – CL (tb-CL)
XFEED (two) – CL (tb-CL)
TK ISOL (all) – CL (tb-CL)
He PRESS (two) – CL (tb-CL) >>

If (feeding) XFEED:

2. L,R RCS MANF ISOL (ten) – CL (tb-CL)
(Receiving) XFEED (two) – CL (tb-CL)
(Feeding) XFEED (two) – CL (tb-CL)
TK ISOL (three) – CL (tb-CL)
He PRESS (two) – CL (tb-CL) >>

If (receiving) XFEED or OMS/RCS I'CNCT:

3. RCS TK ISOL (three) – CL (tb-CL)
He PRESS (two) – CL (tb-CL)

I'CNCT: L OMS to RCS

GNC 23 RCS

NOTE

Gauging not avail in OPS 3

1. DAP: FREE
2. L,R RCS TK ISOL (six) – CL (tb-CL)
XFEED (four) – OP (tb-OP)
3. If RCS MANF P (OX and FU) > 130 continue;
otherwise, √MCC >>
4. √L OMS He PRESS/VAP ISOL (two) – CL
TK ISOL (two) – OP (tb-OP)
√R OMS XFEED (two) – CL (tb-CL)
L OMS XFEED A – CL (tb-CL)
B – OP (tb-OP)
5. L OMS TO AFT – ITEM 5 EXEC
6. DAP: as reqd

I'CNCT: R OMS to RCS

GNC 23 RCS

NOTE

Gauging not avail in OPS 3

1. DAP: FREE
2. L,R RCS TK ISOL (six) – CL (tb-CL)
XFEED (four) – OP (tb-OP)
3. If RCS MANF P (OX and FU) > 130 continue;
otherwise, √MCC >>
4. √R OMS He PRESS/VAP ISOL (two) – CL
TK ISOL (two) – OP (tb-OP)
√L OMS XFEED (two) – CL (tb-CL)
R OMS XFEED A – CL (tb-CL)
B – OP (tb-OP)
5. R OMS TO AFT – ITEM 6 EXEC
6. DAP: as reqd

OPCL/ALL/GEN M

RCS SECURE

8-3

I'CNCT: OMS to RCS

**I'CNCT TK SWITCH:
From L to R OMS FEED**

GNC 23 RCS

1. DAP: FREE
2. L OMS XFEED B – CL (tb-CL)
R OMS XFEED B – OP (tb-OP)
3. R OMS TO AFT – ITEM 6 EXEC
4. DAP: as reqd

**I'CNCT TK SWITCH:
From R to L OMS FEED**

GNC 23 RCS

1. DAP: FREE
2. R OMS XFEED B – CL (tb-CL)
L OMS XFEED B – OP (tb-OP)
3. L OMS TO AFT – ITEM 5 EXEC
4. DAP: as reqd

I'CNCT RETURN (OPS 2,3)

GNC 23 RCS

1. DAP: FREE
2. OMS OFF – ITEM 7 EXEC
3. √OMS TK ISOL (four) – OP (tb-OP)
XFEED (four) – CL (tb-CL)
4. L,R RCS XFEED (four) – CL (tb-CL)
TK ISOL (six) – OP (tb-OP)
5. DAP: as reqd

XFEED: R RCS to L RCS

1. DAP: FREE
2. √L,R OMS XFEED (four) – CL (tb-CL)
3. RCS TK ISOL (six) – CL (tb-CL)
XFEED (four) – OP (tb-OP)
4. If RCS MANF P (OX and FU) > 130, continue;
otherwise, √MCC >>
5. R RCS: √He PRESS A(B) – GPC (tb-OP)
√B(A) – CL (tb-CL)
TK ISOL (three) – OP (tb-OP)
6. MSTR RCS XFEED – FEED FROM R
7. DAP: as reqd

XFEED: L RCS to R RCS

1. DAP: FREE
2. √L,R OMS XFEED (four) – CL (tb-CL)
3. RCS TK ISOL (six) – CL (tb-CL)
XFEED (four) – OP (tb-OP)
4. If RCS MANF P (OX and FU) > 130, continue;
otherwise, √MCC >>
5. L RCS: √He PRESS A(B) – GPC (tb-OP)
√B(A) – CL (tb-CL)
TK ISOL (three) – OP (tb-OP)
6. MSTR RCS XFEED – FEED FROM L
7. DAP: as reqd

XFEED RETURN: RCS

1. DAP: FREE
2. MSTR RCS XFEED – OFF
3. AFT L,R RCS XFEED (four) – CL (tb-CL)
TK ISOL (six) – OP (tb-OP)
√He PRESS A(B) (two) – GPC (tb-OP)
√B(A) (two) – CL (tb-CL)
4. DAP: as reqd

OPCL/ALL/GEN M

I'CNCT TK SW
I'CNCT RETURN

8-5

XFEED: RCS to RCS
XFEED RETURN

RCS RM LOSS

GNC 23 RCS

If vernier jets:

If loss of FAIL OFF detection:

1. Resel >>

If BCE BYP (B or D), MDM fail, or loss of LK detection:

If only L5L and/or R5R aff:

2. Aff jet – desel >>

If L5D,R5D,F5L, and/or F5R aff:

3. (Aff) RCS MANF ISOL 5 – CL (tb-CL)
4. Go to LOSS OF VERNIERS (ORB OPS, RCS) >>

If primary jets:

If loss of FAIL OFF or LK detection:

5. Aff jet – DES INH (*) (reprioritize)
6. If auto deselected: resel
7. At seat ingress: Go to AFT(FWD) RCS RM LOSS (ENT PKT, RCS) >>

If loss of FAIL ON detection:

8. If att control still avail: Ovrđ STAT closed for all MANFs on (aff) RJD and (aff) RJD – OFF
9. Aff jet – DES INH twice (reprioritize, reset RM)
10. At seat ingress: Go to AFT(FWD) RCS RM LOSS (ENT PKT, RCS) >>

If BCE BYP (B or D), or MDM fail:

11. If att control still avail: Leave STAT closed for all MANFs on (aff) RJD and (aff) RJD – OFF
12. Aff jet – DES INH twice (reprioritize, reset RM)
13. At seat ingress: Go to AFT(FWD) RCS RM LOSS (ENT PKT, RCS)

RM DLMA MANF

1. √(Aff) RCS MANF ISOL – GPC
- ◆ 2. RCS MANF VLVS OVRD – ITEM 40(41,42,43,44) EXEC
3. Go to MAL, RCS, 10.1b, RM DLMA MANF 1

RCS TK P LOW (FU or OX)

GNC SYS SUMM 2

1. $\sqrt{\text{FU(OX) He P (CRT \& meter)}}$

If decr:

2. Go to RCS LEAK ISOL, step 1 >>

If not decr:

3. (Aff) RCS He PRESS A(B) – CL (tb-CL)
B(A) – OP (tb-OP), GPC (tb-OP)
4. Go to MAL, RCS, 10.1a 64

RCS TK P HIGH (FU or OX)

GNC 23 RCS

1. (Aff) RCS He PRESS (two) – CL (tb-CL)
2. Go to MAL, RCS, 10.1a 55

RCS JET FAIL (ON)

GNC 23 RCS

1. (Aff) RCS MANF ISOL – CL (tb-CL)
2. Go to MAL, RCS, 10.1a 13

RCS JET FAIL (LEAK)

GNC 23 RCS

If RCS FU and OX qty diverging:

1. (Aff) RCS MANF ISOL – CL (tb-CL)
2. Go to MAL, RCS, 10.1a 21

RCS JET FAIL (OFF)

GNC 23 RCS

If FAIL OFF(s) caused by pwrdn of RJDs:

1. RJD LOGIC, DRIVER – ON
2. JET RESET – ITEM 45 EXEC
3. Resel all FAIL OFF jets
4. JET RESET – ITEM 45 EXEC

Otherwise:

5. Go to MAL, RCS, 10.1a 1

OPCL/ALL/GEN M,9

**RCS RM LOSS
RM DLMA MANF**

8-7

**RCS TK P LO/HI
RCS JET FAIL**

RCS LEAK ISOL

GNC SYS SUMM 2

1. If FU or OX TK P high, go to RCS TK P HIGH (FU or OX) >>

If FU or OX TK P normal:

2. $\sqrt{\text{FU(OX) He P}}$ (CRT and O3 meter) decr

3. DAP: FREE

When proc complete:

4. If not loss of VERNs: DAP as reqd

SECURE RCS

5. Perform aff RCS SECURE, then:

If aff RCS was receiving XFEED/I'CNCT when leak occurred:

6. Go to step 10

$\sqrt{\text{SINGLE MANF}}$

If only one MANF P decr:

7. Return to normal config except leave aff MANF closed >>

$\sqrt{\text{PRPLT TK LEG (TWO MANF P)}}$

If MANF 1,2 or MANF 3,4 P decr:

8. Return to normal config except leave aff TK ISOL (1/2 or 3/4/5),
MANFs, and corresp XFEED vlvs closed

If MANF 3/4/5 leg leak:

9. Go to LOSS OF VERNIERS (ORB OPS, RCS) >>

Cont next page

√He TK

If He P decr:

10. √MCC for use of MAL, RCS SSR-5, LEAKING RCS PRPLT/
He BURN

If no comm or burn not performed:

If AFT RCS:

11. Perform XFEED from leaking RCS, then:
When He TK P < 456:
 12. (Aff) RCS He PRESS A,B – CL (tb-CL)
 13. Go to I'CNCT: L(R) OMS to RCS >>

If FWD RCS:

14. Return to normal config
When He TK P < 456:
 15. FWD RCS He PRESS A,B – CL (tb-CL)
- When PRPLT TK P < 190:
 16. Perform RCS SECURE (FWD), then:
 17. Go to LOSS OF VERNIERS (ORB OPS, RCS) >>

If burn performed:

If AFT RCS >>

If FWD RCS:

- When PRPLT TK P < 190:
 18. Perform RCS SECURE (FWD), then:
 19. Go to LOSS OF VERNIERS (ORB OPS, RCS) >>

√PRPLT TK

If PRPLT TK P decr:

20. Go to MAL, RCS SSR-5, LEAKING RCS PRPLT/He BURN >>

√He LEG

21. (Aff) RCS He PRESS A,B – OP (tb-OP)

If He P decr:

If AFT RCS:

22. (Aff) RCS He PRESS A,B – CL (tb-CL)
23. Perform I'CNCT: L(R) OMS to RCS, then:
24. (Aff) MANFs (all) – OP (tb-OP), GPC
- Prior to deorb TIG:
 25. Return to RCS straight feed
 26. (Aff) RCS He PRESS A,B – CL (tb-CL)
 27. Cycle He PRESS A(B) to maintain PRPLT TK P
220-245

When He TK P < 456:

28. Perform I'CNCT: L(R) OMS to RCS, then:

At EI:

29. Go to XFEED: L(R) RCS to R(L) RCS >>

Cont next page

OPCL/ALL/GEN M

T

If FWD RCS:

30. Return to normal config
 31. (Aff) RCS He PRESS A,B – CL (tb-CL)
 32. Cycle He PRESS A(B) to maintain PRPLT TK P 220-245
- When He TK P < 456:
33. GNC 23 RCS
Ovrd FWD MANFs STAT – CL
 34. Perform LOSS OF VERNIERS (ORB OPS, RCS), then:
Prior to deorb:
 35. Ovrd FWD MANFs STAT – OP
- When PRPLT TK P < 190:
36. Go to RCS SECURE >>

√XFEED LINES

If aff RCS was feeding XFEED when leak occurred:

37. GNC 23 RCS
RCS L – ITEM 2 EXEC
- If XFEED P decr or zero:
38. L,R RCS He PRESS A(B) (two) – GPC (tb-OP)
B(A) (two) – CL (tb-CL)
TK ISOL (six) – OP (tb-OP)
MANF ISOL (ten) – OP (tb-OP), GPC
 39. Do not XFEED/I'CNCT >>

√RCS MANF ISOL 5

If leak not found above:

40. Reconfig sys as reqd
41. (Aff) RCS MANF ISOL 5 – CL
– GPC (tb-CL)
42. Perform LOSS OF VERNIERS (ORB OPS, RCS), then:
43. Go to MAL, RCS, 10.1a 75



MPS

MAIN PROPULSION SYSTEM



MPS

MPS C/W

MPS PNEU He ISOL – OP
FILL/DRAIN LH2 OUTBD – OP
INBD – OP
LO2 OUTBD – OP
INBD – OP

√MCC

PWRDN

LOSS OF 2 CAB FANS	10-2
2 H2O LOOPS	10-7
CAB PRESS.....	10-27
HI LOAD EVAP	10-33
1 FREON LOOP	10-35
1 FC.....	10-39
2nd FC ON-ORBIT (TIG < 4 hr)	10-41
(TIG > 4 hr)	10-45
2 FREON LOOPS	10-49
FES	10-69
AV BAY FIRE.....	10-73
1	10-73
2	10-77
3A.....	10-81

PWRDN

OV103,104

A10-1

OPCL/ALL/GEN M

LOSS OF 2 CAB FANS

- MS1,2 1. Perform MS PWRDN, 10-5, ASAP

NOTE

Normal CO2 removal and humidity control lost.
Wipe off any visible moisture with towel.

Cab press increase due to air heating may
cause CAB PRESS RELIEF vlv cycling

PWRDN

- C3 2. MSTR MADS PWR – OFF
 3. Minimize Itg
- FWD 4. All MDU PWR (nine) – OFF
C2 All IDP/CRTs (three) – OFF
F6/F8 √FLT CNTLR PWR (two) – OFF
 If FLT CNTLR PWR not reqd:
- O14,O15, 5. cb DDU L,R,AFT (six) – op
O16:E
- L1 6. CAB FAN A,B (two) – OFF
 TEMP CNTLR – OFF
 7. HUM SEP A,B (two) – OFF
 8. Use one PGSC
- W1-10 9. Install Window Shades or mnvr to tail Sun att
 GNC 201 UNIV PTG
 TGT ID – ITEM 8 +4 EXEC
 BODY VECT – ITEM 14 +5 EXEC
 P – ITEM 15 +1 8 4 EXEC
 Y – ITEM 16 +0 EXEC
 OM – blank (MCC-provided if reqd)
- C3 DAP: A/AUTO/VERN
CRT START TRK – ITEM 19 EXEC (*)
10. Cycle MDUs. If ON at loss of cooling, turn OFF within
 30 min. Allow 3 min OFF prior to each 1 min ON (30
 min max ON time). Save two MDUs that interface with
 a single IDP for entry

Cont next page

OV103,104

A10-2

OPCL/ALL/GEN M

NOTE

Don QDM for temp > 90 degF and discomfort.
If cab temp > 95 degF and no evaporative
cooling is sensed, don LES, check tabs, close
visor, LES O2 – ON.

Inflate anti-g suit as needed for on-orbit
circulatory support.

Begin drinking H2O (one 8-oz container every
15 min with a salt tablet in every other
container) and continue through entry

11. Go to LOSS OF 2 CAB FANS (DEORB PREP,
CONTINGENCY DELTAS) and perform at next PLS
opportunity. Expedite NOMINAL DEORBIT PREP proc
if time-to-TIG < 3.5 hr

OV103,104

A10-3

OPCL/ALL/GEN M

This Page Intentionally Blank

OV103,104

A10-4

OPCL/ALL/GEN M

MS PULLOUT PAGE

MS1 Perform PLB EQUIP PWRDN, 10-6
MS2 Perform MS PWRDN ASAP

MS PWRDN

O14:B 1. Minimize Itg
:C 2. cb MNA EVENT TIMER AFT – op
SMOKE DETN L/R FLT DK – op
O15:B 3. MNB OI H2O BYP LOOP 2 SNSR – op
MSN TIMER AFT – op
O16:C 4. MNC SMOKE DETN CAB – op
L4:J 5. AC3 Φ A SIG CONDR HUM SEP – op
A6U 6. ANNUN BUS SEL – OFF
A13 7. OS AUD SPKR PWR – OFF

NOTE

Galley OVEN/RHS sw should be
OFF unless dispensing H2O

GALLEY 8. OVEN/RHS – ON, as reqd
H2O HTRS (two) – OFF
MA73C:G 9. cb AC3 GALLEY FAN (three) – op
ML86B:B 10. MNB GALLEY H2O HTR – op
If RMS pwr dn:
A3 11. MON 1,2 PWR (two) – OFF
A7U 12. TV PWR CNTL – PNL
CONTR UNIT – OFF
13. VID OUT MON1,MON2 pb (two) – push
(MON1,MON2 It on)
O19 14. TV PWR – OFF
R12L 15. VTR PWR – OFF
MO58F 16. TV PWR – OFF
If not reqd:
R11L 17. IDP/CRT4 PWR – OFF
CRT4,AFD1 MDU PWR – OFF
A6U 18. FLT CNTLR PWR – OFF

**LOSS OF 2 CAB FANS
ON-ORBIT
MS PAGE**

A10-5

OV103,104

OPCL/ALL/GEN M,6

PLB EQUIP PWRDN

1. Perform PL SAFING, then:

<p style="text-align: center;"><u>CAUTION</u> If stow prob occurs with either RMS and/or KU-BD ANT, perform aff sys <u>QUICK RESPONSE JETTISON (CONT DEORB)</u></p>
--

If RMS grappled to OBSS:

2. Perform OBSS JETTISON (PDRS OPS FS,
OBSS CONTINGENCY), then:

If RMS-only:

3. Perform RMS PWRDN (PDRS OPS), then:

If KU-BD ANT deployed:

4. Perform KU-BD ANT STOW (ORB OPS,
COMM/INST), then:

If radiators deployed:

5. Go to RAD STOW (ORB OPS, ECLS)

**LOSS OF 2 CAB FANS
ON-ORBIT
MS PAGE**

A10-6

OV103,104

OPCL/ALL/GEN M

LOSS OF 2 H2O LOOPS

NOTES

- THIS PROCEDURE IS TIME CRITICAL
 - Proc requires > 45 min, but time critical steps should be done ASAP
 - Loss of H2O cooling aff both water and air cooled equipment
 - Proc pwrns dn all comm. If comm reqd, preferred comm config in order of heat production:
 1. UHF only
 2. SGLS/STDN LO PWR if reqd
 3. TDRS only if mandatory (10 min max)
 - Call ground at every avail UHF site
 - Tear out COMM pages from proc and use until touchdown
 - Cab depress/repress cycles to 10.2 psia are used for cab temp and humidity control
 - If docked to ISS, proc is to be worked simo with JOINT EXPEDITED UNDOCKING AND SEPARATION (SODF: JOINT OPS)
 - When pwrdns complete, perform actions on 10-19 and 10-20 as time permits at crew discretion
1. Perform PART 1 of this pwrdn and, based on TIG, complete PART 2 or PART 3

Cont next page

A10-7

OV103,104

OPCL/ALL/GEN M

LOSS OF 2 H2O LOOPS, PART 1 – INITIAL PWRDN

TIME CRITICAL PROCEDURES (execute simo)

1. Record MET of 2nd H2O Loop Fail
2. / : :
Establish comm plan with MCC, determine best TIG opportunities, then have MS3 perform COMM PWRDN, 10-23, ASAP (S-Bd Pwr Amp may fail in 10 min with no cooling)
3. Have MS perform MS OVHD PNL PWRDN, 10-19, ASAP
4. Have second MS perform MCA CONFIG, 10-17, and PLB EQUIP PWRDN, 10-17, ASAP
5. If docked to ISS, have CDR perform JOINT EXPEDITED UNDOCKING AND SEPARATION (SODF: JOINT OPS)
6. Have PLT proceed with CDR AND PLT PWRDN, ASAP

DETERMINE MAXIMUM TIME TO TIG, NUMBER OF DEP/REP, FROM N2 QTY FROM SPEC 66. Sel best landing site and deorbit TIG from PGSC. Set Wristwatch Timer (A17) counting down to TIG.

TIG:	_____
TGTS:	_____
C1	_____
C2	_____
HT	_____
ØT	_____

Enter TARGETS in LOSS OF 2 H2O LOOPS DEORBIT PREP/ENTRY (CONT DEORB, LOSS OF 2 H2O LOOPS D/O PREP)

<u>IF TOTAL N2</u>	<u>NUMBER OF DEP/REP</u>	<u>SEL BEST TIG WITHIN</u>
>160 LB	3	45M - 4H:00M
>120 LB	2	45M - 2H:50M

CDR AND PLT PWRDN

- O14,O15, O16:F 7. √Pri RJD LOGIC,DRIVER (sixteen) – ON
DAP: ALT (proc results in loss of VERNs)
RJD MANF L5/F5/R5 DRIVER – OFF
- O16:F C3 8. √MSTR MADS PWR – OFF
9. Minimize Itg
10. Use only one IDP with two MDUs, one PGSC

NOTE

Cycle MDUs. If ON at loss of cooling, turn OFF within 30 min. Allow 2 min OFF prior to each 1 min ON (30 min max ON time). Save two MDUs that interface with a single IDP for entry. IDPs do not require cycling

Cont next page

OV103,104

A10-8

OPCL/ALL/GEN M

- F6,F8,A6 11. FLT CNTLR PWR (three) – OFF, use one as reqd
- O7 12. √TACAN MODE sel (three) – OFF
- O8 13. √RDR ALTM (two) – OFF
- 14. √MLS (three) – OFF

- L1 15. √H2O PUMP LOOP 1,2 (two) – OFF
(leave ON if any loop running)
HUM SEP (two) – OFF
(leave HUM SEP A ON if any loop running)

If any loop running, minimize bypass:

- 16. H2O LOOP 1(2) BYP MODE – MAN
MAN – DECR (30 sec)

If H2O PUMP LOOP 1 A(B) ON, inform MS:

- MA73C:A 17. √MCA LOGIC MNA FWD 1 – ON
(MNB FWD 2 – ON)

- L1 18. CAB FAN (two) – OFF
TEMP CNTLR – OFF
- 19. √FLOW PROP VLV LOOP tb (two) – ICH
- 20. FREON PUMP LOOP 1 – OFF
√2 – B
- 21. HI LOAD DUCT HTR sel – A/B
√TOP EVAP HTR NOZ L,R (two) – B AUTO(A AUTO)
√DUCT sel – B(A)

- L2 22. O2 SYS 1 SPLY – CL (tb-CL)
- L4:J 23. cb AC3 ϕA SIG CONDR HUM SEP – op

If not currently single G2, reassign strings to GPC 1 in MC 2:

- 24. GNC 0 GPC MEMORY
CONFIG – ITEM 1 +2 EXEC
Modify MC 2 per table ----->
- CRT 25. GNC, OPS 201 PRO
- O6 26. GPC MODE 2 – STBY
(tb-bp)
– HALT
– STBY
(tb-RUN)
– HALT
(tb-bp)
- 27. √GPC MODE 3,5 (two) – HALT
√OUTPUT 5 – NORM
- L1 28. AV BAY 1 FAN A – ON
B – OFF
2,3 FAN A,B (four) – OFF
- 29. IMU FAN A – ON
B – OFF
√C – OFF

	CONFIG	2
	GPC	10000
STR	1	1
	2	1
	3	1
	4	1
PL	1/2	0
CRT	1	1
	2	1
	3	0
	4	1
L	1	0
	2	0
MM	1	1
	2	1

For any fwd IDP/CRT that is OFF:

- 30. GPC/CRT1/X EXEC
- R2 31. HYD CIRC PUMP (three) – ON

Cont next page

OV103,104

A10-9

OPCL/3,4/GEN M

C3 32. C/W MODE – ACK

NOTE

For F7 lights, hold in F2 or F4 MA

If current time to TIG < 50 min:

33. Go to LOSS OF 2 H2O LOOPS, PART 2 – SHORT ON-ORBIT WAIT, next page >>

L1 34. Cycle CAB FAN A(B) – ON (7 min)/OFF (1 hr)
(to control PPCO2)

L4:P 35. cb AC2,3 Φ A LG SNSR (two) – op

WARNING

Do not unpwr all IMU/FF MDM's pairs

If IMU 2 in OPER:

O14,O16:A 36. GNC 21 IMU ALIGN
IMU 1,3 (two) – desel
37. IMU 1,3 (two) – OFF

If IMU 2 in STBY:

O15,O16:A 38. GNC 21 IMU ALIGN
IMU 2,3 (two) – desel
O6 39. IMU 2,3 (two) – OFF
40. MDM FF3,FF4 (two) – OFF
41. Verify MS OVHD PWRDN complete

NOTE

Both MMUs are OFF. If a ROLL-IN DISPLAY is reqd: turn MMU 1 ON, try transaction, turn MMU 1 OFF again

If time from failure to TIG < 2 hr 30 min:

42. Go to LOSS OF 2 H2O LOOPS, PART 2 – SHORT ON-ORBIT WAIT, next page >>

If time from failure to TIG > 2 hr 30 min:

43. Go to LOSS OF 2 H2O LOOPS, PART 3 – EXTENDED ON-ORBIT WAIT, 10-13

OV103,104

A10-10

OPCL/ALL/GEN M

LOSS OF 2 H2O LOOPS, PART 2 – SHORT ON-ORBIT WAIT

If Undocking from ISS, delay step 1 until after Undocking and Post Final Sep, but continue with steps 2 through 19 of PART 2 – SHORT ON-ORBIT WAIT:

1. Perform POST UNDOCKING AND FINAL SEP RECONFIG, 10-15

BYPASS RADS/FES ACT

- | | | |
|---------|----|---|
| ML86B:A | 2. | cb MNC SPLY H2O XOVR VLV – cl |
| R11L | 3. | SPLY H2O XOVR VLV – OP (tb-OP)
√TKA OUTLET – CL (tb-CL) |
| L1 | 4. | FLASH EVAP CNTLR (three) – OFF |
| | 5. | HI LOAD EVAP – ENA
RAD BYP VLV MODE 1,2 (two) – MAN
MAN SEL 1,2 (two) – BYP,
wait 3 sec (tb-BYP)
CNTLR LOOP 1,2 (two) – OFF |

When EVAP OUT T > 65:

6. FLASH EVAP CNTLR PRI A(B) – ON
7. Wait 1 min, verify EVAP OUT T = 39 degF
8. Give MS GO to perform PLBD CLOSURE, 10-18

If current time to TIG < 50 min, at TIG-30 min:

9. Go to LOSS OF 2 H2O LOOPS DEORBIT PREP/ENTRY (CONT DEORB, LOSS OF 2 H2O LOOPS D/O PREP) >>

NOTE

Limit operation of each GPC (1 hr max ON time from second H2O Loop failure)

If reqd, perform steps 10 thru 13:

- | | | |
|------|-----|--|
| O6 | 10. | GPC MODE 2 – STBY (tb-RUN), hands off 10 sec
– RUN (OUTPUT tb-gray), hands off
10 sec |
| IDPX | 11. | In MCX add GPC 2 to tgt set (leave GPC 1 in tgt set)
Assign all strings to GPC2
(if SM GPC active, √PL 1/2 not assigned)
GNC, OPS X01 PRO
√All IDPs deassigned from GPC1 |
| O6 | 12. | GPC MODE 1 – STBY (tb-bp)
– HALT
– STBY (tb-RUN)
– HALT (tb-bp) |
| L1 | 13. | AV BAY 1 FAN A(B) – OFF
2 FAN A(B) – ON |

Wherever GPC 1 is referenced, replace with GPC 2 in the LOSS OF 2 H2O LOOPS DEORBIT PREP/ENTRY (CONT DEORB, LOSS OF 2 H2O LOOPS D/O PREP)

Cont next page

OV103,104

A10-11

OPCL/ALL/GEN M

SM GPC/PL MDM Deact – Delay SM GPC/PL MDM Deact (steps 14-21) until PLBD are closed. Then perform ASAP:

- 14. SM 1 DPS UTILITY
UL CNTL ENA – ITEM 36 EXEC
- C3 15. UPLK – GPC BLK
- C2 16. IDP/CRT1,2,3 MAJ FUNC (three) – GNC
- O6 17. GPC MODE 4 – STBY (tb-bp)
– HALT
PWR 4 – OFF
- 18. GNC 0 GPC MEMORY
CONFIG – ITEM 1 +2 EXEC
- 19. Assign PL1/2 to GPC 1 in MC2
- CRT 20. GNC, OPS 201 PRO
- O6 21. MDM PL1,PL2 (two) – OFF
- 22. Perform first cab depress/repress cycle starting at approx 1 hr 15 min after the failure, the final cycle at TIG-20 min. Procs in the 20 MINUTE DE/REPRESS MS PULLOUT PAGE (CONT DEORB, LOSS OF 2 H2O LOOPS); use until last depress/repress is complete

NOTE

Possible cab air OVBD RLF due to loss of cab cooling.

Use Quick Don mask as needed to provide additional respirator cooling during periods of high cab temp and humidity. To determine health of crewmember, place temp strip (MED Kit) on forehead. If any crewmember temp greater than 99 degF and crew feels ill, begin cab depress/repress cycle ASAP

At TIG-30 min:

- 23. Go to LOSS OF 2 H2O LOOPS DEORBIT PREP/ENTRY (CONT DEORB, LOSS OF 2 H2O LOOPS D/O PREP) >>

OV103,104

A10-12

OPCL/ALL/GEN M

LOSS OF 2 H2O LOOPS, PART 3 – EXTENDED ON-ORBIT WAIT

If Undocking from ISS, delay step 1 until after undocking and Post Final Sep, but continue with steps 2 thru 6:

1. Perform POST UNDOCKING AND FINAL SEP RECONFIG, 10-15
- O6 2. \sqrt GPC MODE 2,3,5 (three) – HALT
3. PWR 2,3,5 (three) – OFF

When RMS PWRDN (PDRS OPS) complete, perform steps 4 thru 6 ASAP:

4. GPC MODE 4 – STBY (tb-bp), hands off 10 sec
– RUN (tb-RUN), hands off 10 sec
OUTPUT 4 – NORM (tb-gray)
5. GNC 0 GPC MEMORY
CONFIG – ITEM 1 +2 EXEC

Modify MC 2 per table ---->
GNC, OPS 201 PRO

CONFIG	2
GPC	10040
STR 1	1
2	1
3	1
4	1
PL 1/2	1
CRT 1	1
2	1
3	1
4	0
L 1	0
2	0
MM 1	1
2	1

- O6 6. GPC MODE 4 – STBY (tb-bp)
– HALT
– STBY (tb-RUN)
– HALT (tb-bp)
PWR 4 – OFF

Delay steps 7 thru 20 of PART 3 – EXTENDED ON-ORBIT WAIT, 10-14, until POST UNDOCKING AND FINAL SEP RECONFIG is complete (perform step 19 as reqd):

Cont next page

OV103,104

A10-13

OPCL/ALL/GEN M

- Establish free drift:
- F8 7. Verify att mnvr complete
ADI ATT – INRTL
 - C3 DAP: B/AUTO/PRI (wait 30 sec)
FREE
 - O6 8. MDM PL1,PL2 (two) – OFF
 - 9. √Wrist watch set to MET
- Pwr dn remaining GPC:
- 10. GNC, OPS 000 PRO
 - 11. GPC MODE 1 – STBY (tb-bp)
– HALT
– STBY (tb-RUN)
– HALT (tb-bp)
 - 12. GPC PWR 1 – OFF
- FWD,AFT 13. All MDU PWR (eleven) – OFF
 - C2,R11L IDP/CRT PWR (four) – OFF
 - L1 14. AV BAY FAN (six) – OFF
 - O13:C 15. cb ESS 2CA MTU B – op
:E 3AB GPC STAT – op
 - O14:B 16. MNA MSN TIMER FWD – op
:C SMOKE DETN L/R FLT DK – op
- W1-10 17. Install Window Shades
 - 18. Check all pwrdns complete
- 19. Perform first cab depress/repress cycle starting at approx 1 hr 15 min after the failure, the second at TIG-1:15 and the final cycle at TIG-20 min. Procs in the 20 MINUTE DE/REPRESS MS PULLOUT PAGE (CONT DEORB, LOSS OF 2 H2O LOOPS); use until last depress/repress is complete
- NOTE
- Possible cab air OVBD RLF due to loss of cab cooling.
- Use QDM as needed to provide additional respirator cooling during periods of high cab temp and humidity. To determine health of crewmember, place temp strip (MED Kit) on forehead of CDR and PLT
- 20. Go to LOSS OF 2 H2O LOOPS, ON-ORBIT WAIT (CONT DEORB, LOSS OF 2 H2O LOOPS)

OV103,104

POST UNDOCKING AND FINAL SEP RECONFIG

If Undocking with ISS and Final Sep complete or if not docked with ISS:

1. **GNC 20 DAP CONFIG**
DAP A,B set to A1,B1 except:
(A) ITEM 10 +1.0 0 EXEC
ITEM 11 +3.0 0 EXEC
ITEM 15 EXEC (TAIL)
ITEM 16 EXEC (TAIL)
(B) ITEM 30 +0.2 0 EXEC
ITEM 31 +1.0 0 EXEC
ITEM 35 EXEC (TAIL)
ITEM 36 EXEC (TAIL)

CAUTION
DO NOT mnvr on PRCS until MS has completed RMS JETT or STOW

2. Mnvr to tail Sun att:
GNC 201 UNIV PTG
TGT ID – ITEM 8 +4 EXEC
BODY VECT – ITEM 14 +5 EXEC
P – ITEM 15 +2 2 5 EXEC
Y – ITEM 16 +0 EXEC
OM – blank (MCC-provided as reqd)
DAP: A/AUTO/PRI
START TRK – ITEM 19 EXEC (CUR-*)

- If IMU 2 in OPER:
O6 | 3. MDM FF1 – OFF
If IMU 2 in STBY:
O6 4. MDM FF2 – OFF
O14,O15, 5. RJDF LOGIC,DRIVER (eight) – OFF
O16:F

NOTE
Expect FRCS jet(s) to false fail leak when OF DSC cbs are opened

6. cb MNA OI SIG CONDR OF 1/4 A – op
7. cb MNB OI SIG CONDR OF 1/4 B – op
2/3 A – op
8. cb MNC OI SIG CONDR OF 2/3 B – op
9. DDU AFT – op

OV103,104

A10-15

OPCL/ALL/GEN M

This Page Intentionally Blank

OV103,104

A10-16

OPCL/ALL/GEN M

MCA CONFIG (Execute ASAP)

- L1 If either H2O PUMP LOOP 1 A(B) – ON:
MA73C:A 1. Leave MCA LOGIC MNA FWD 1(MNB FWD 2) ON
B in next step

CAUTION
Coordinate steps 2 and 3 with CDR. FRCS
is lost with step 2 and recovered with step 3

- MA73C:A, 2. MCA LOGIC MNA,B,C (fourteen) – OFF
B
3. **GNC 23 RCS**
ITEM 1 EXEC (FRCS page)
OVRD FRCS MANF(s) – OP
4. For PLB EQUIP PWRDN, use following MCA config:
MCA LOGIC MNA MID 1,3 (two) – ON
MNB MID 2,3,4 (three) – ON
MNC MID 2,4 (two) – ON

CAUTION
Retain this MCA sw config until step 8 of the PLB
EQUIP PWRDN. Disregard MCA sw throws in the
PL SAFING, RAD STOW, KU-BD ANT STOW,
and RMS PWRDN procs

- MO13Q 5. \sqrt AIRLK FAN A,B (two) – OFF

PLB EQUIP PWRDN (Execute ASAP)

1. Perform PL SAFING, then:

CAUTION
If stow prob occurs with either RMS and/or
KU-BD ANT, perform aff sys QUICK
RESPONSE JETTISON (CONT DEORB)

2. If TV reqd for OBSS jettison or RMS/Ku stow, perform
ACTIVATION and OPERATION (Auto Ops only) (Cue
Card, TV)

If RMS grappled to OBSS:

3. Perform OBSS JETTISON (PDRS OPS FS,
OBSS CONTINGENCY), then:

If RMS-only:

4. Perform RMS PWRDN (PDRS OPS), then:

Cont next page

LOSS OF 2 H2O LOOPS
ON-ORBIT
MS PAGE

OV103,104

A10-17

OPCL/ALL/GEN M

If KU-BD ANT deployed:

5. Perform KU-BD ANT STOW (ORB OPS, COMM/INST), then:

If radiators deployed:

6. Perform RAD STOW (ORB OPS, ECLS), then:
 7. Notify CDR: RMS stowed(jettisoned)
- If performing PART 2 – SHORT ON-ORBIT WAIT:
8. Perform PLBD CLOSURE, below, on GO from CDR, then:

- MA73C:A, 9. MCA LOGIC MNA MID 1,3 (two) – OFF
B MNB MID 2,3,4 (three) – OFF
MNC MID 2,4 (two) – OFF

PLBD CLOSURE (Short On-Orbit Wait only)

WARNING

Verify no obstructions before closing and latching PLBD (Ku ANT, RAD, RMS, etc)

1. Notify CDR: Beginning PLBD CLOSURE
- O6 2. \sqrt MDM PL1, PL2 (two) – ON
3. SM I/O RESET
- CRT4 4. SM, OPS 202 PRO – close PLBD ASAP
5. SM PL BAY DOORS
- R13L PL BAY DR SYS (two) – ENA
- CRT4 6. AC POWER ON – ITEM 1 EXEC
AUTO MODE SEL – ITEM 3 EXEC
PBD SW BYPASS – ITEM 14 EXEC
CLOSE – ITEM 17 EXEC
- If 'PLB SEQ FAIL' msg during door closure and aft latches for that door are not 'CL':
7. Check door scallop on or below tgt line before continuing in MAN mode; otherwise:
 8. Perform MAL, MECH SSR-2, CONTINGENCY PLBD CLOSURE, then:
- After PLBD closed:
- CRT4 9. PBD STOP – ITEM 16 EXEC
AC POWER OFF – ITEM 2 EXEC
- R13L 10. PL BAY DR SYS (two) – DSBL
GPC/CRT 0/4 EXEC
- R11L 11. IDP/CRT4 PWR – OFF
- A7U 12. \sqrt PL BAY FLOOD (all) – OFF
If either H2O PUMP LOOP 1 A(B) – ON:
- MA73C:A 13. Leave MCA LOGIC MNA FWD 1
(MNB FWD 2) – ON in next step
- MA73C 14. MCA LOGIC MNA,B,C (fourteen) – OFF
15. Notify CDR: PLBDs closed

**LOSS OF 2 H2O LOOPS
ON-ORBIT
MS PAGE**

OV103,104

A10-18

OPCL/ALL/GEN M

MS OVHD PNL PWRDN

1. Set wrist watches as accurately as possible to MET (set one to GMT). The MET may be used for deorbit burn execution. Record GMT day of year
____/____:____:____
 2. Minimize Itg on Aft Flt Deck
 - O13:A 3. cb ESS 1BC MTU A – op
 - :C 2CA C/W B – op
 - O14:A 4. √BRAKES MNA – OFF
 - :B 5. cb MNA OI H2O BYP LOOP 1 SNSR – op
 - :E EVENT TIMER AFT – op
 - √ADTA 1 – op
 - DDU L,AFT (two) – op
 - O15:A 6. √BRAKES MNB – OFF
 - :B 7. cb MNB OI H2O BYP LOOP 2 SNSR – op
 - :E MSN TIMER AFT – op
 - EVENT TIMER FWD – op
 - √ADTA 2 – op
 - DDU L,R (two) – op
 - :F 8. MMU 2 – OFF
 - O16:A 9. √BRAKES MNC – OFF
 - :E 10. √cb MNC ADTA 3,4 (two) – op
 - DDU R – op
- When N2 QTY and TIG determined by CDR:
- O14:B 11. cb MNA OI MDM OF 1/2 A,3/4 A (two) – op
 - O15:B MNB OI MDM OF 1/2 B – op
 - O16:B MNC OI MDM OF 3/4 B – op
 - O14:F MMU 1 – OFF
 - A13 12. GPS PWR – OFF
 13. Notify CDR: MS OVHD PNL PWRDN complete
 14. Assist other MS with completion of PLB EQUIP PWRDN, 10-17

**LOSS OF 2 H2O LOOPS
ON-ORBIT
MS PAGE**

A10-19

OV103,104

OPCL/3,4/GEN M

When pwrdns complete, perform following at crew discretion:

FLUID LOADING PREP

- GALLEY
1. OVEN/RHS – ON
 2. Unstow, fill 4 water containers (per crewmember) with 8 oz of water each. Temp stow near seat
 3. Unstow 8 salt tablets (per crewmember). Temp stow in Flt Suit pocket
 4. OVEN/RHS – OFF
 5. √H2O HTRS (two) – OFF
 6. √OVEN FAN – OFF
 7. Stow Personal Hygiene Hose

NOTE

Ensure sufficient containers and salt tablets are prepared to continue fluid loading thru entry

FLUID LOADING

1. Immed begin drinking H2O (one 8-oz container every 15 min with a salt tablet in every other container) and continue through entry

CLOTHING CONFIG

1. Don QDM for temp > 90 degF and discomfort

FDF CONFIG

1. Unstow: ENT, ENT PKT, Deorb Burn Cards, ENT Cue Cards

CAB CONFIG

1. Stow loose equipment, Backup PGSC
2. Remove and stow side hatch UV filter, locking device, and pyro box safing pin
3. Tape foot loops in egress routes
4. Remove and stow Window Shades (if not needed for cab T control)

**LOSS OF 2 H2O LOOPS
ON-ORBIT
MS PAGE**

A10-20

OV103,104

OPCL/ALL/GEN M

WCS DEACT

- WCS 1. Foot Restraints – up, locked
ML31C 2. √VAC VENT ISOL VLV CNTL – OP (tb-OP)

INSTALL SEATS

POLE SETUP

1. ESCAPE POLE SETUP:
 - Reinstall Stbd pip pin and Large Port pin
 - Retract and hold Locking Pin(Ring)
 - Reinstall Large pin
 - Release Locking Pin(Ring)
 - Slide forward Safing latch
 - Verify pole straps secure
2. Check minimum lgt on Middeck

**LOSS OF 2 H2O LOOPS
ON-ORBIT
MS PAGE**

A10-21

OV103,104

OPCL/ALL/GEN M,6

This Page Intentionally Blank

**LOSS OF 2 H2O LOOPS
ON-ORBIT
MS PAGE**

A10-22

OV103,104

OPCL/ALL/GEN M

NOTE
KEEP THIS PAGE UNTIL TOUCHDOWN

MS After comm plan established with MCC, perform COMM
PWRDN ASAP (delay 10 min max)

CAUTION
Must complete steps 1 thru 3 within 10 min.
TDRS or STDN – HI AOS is limited to 10 min
or power amp will overheat

NOTE
Proc pwrs off ALL ground comm

COMM PWRDN

- A1L 1. S-BD PM ANT SW ELEC – OFF
 PRE AMP – OFF
 PWR AMPL STBY – OFF
 OPER – OFF
 MODE sel – STDN LO
 XPNDR – OFF
2. NSP PWR – OFF
 ENCRYPTION PWR – OFF
 (Encrypt OFF rest of flt)
 MODE – SEL
 SEL – BYP

NOTE
Verify CDR ready for COMM PWRDN prior to
performing step 3

- C3 3. S-BD PM CNTL – PNL

NOTE
Ensure CDR has recorded N2 quantities before
powering down PCMMU. Other steps may be
performed

4. OI PCMMU PWR – OFF
 FORMAT – FXD
5. AUD CTR – OFF (turn ON as reqd for ICOM audio)

**LOSS OF 2 H2O LOOPS
ON-ORBIT
MS PAGE**

A10-23

OV103,104

OPCL/ALL/GEN M

NOTE
KEEP THIS PAGE UNTIL TOUCHDOWN

- | | | |
|--------|-----|---|
| O5 | 6. | L AUD PWR – OFF (turn ON as reqd for ICOM audio) |
| O6 | 7. | UHF MODE sel – OFF |
| O9 | 8. | R AUD PWR – OFF (turn ON as reqd for ICOM audio) |
| A1L | 9. | √S-BD PL CNTL – PNL
√PWR SYS – OFF |
| | 10. | PL DATA INTLVR PWR – OFF |
| A1R | 11. | S-BD FM CNTL – PNL
PWR – OFF |
| A3 | 12. | MON 1,2 PWR (two) – OFF |
| A7U | 13. | TV PWR CONTR UNIT – OFF |
| R14:B | 14. | cb MNA,MNC GCILC (two) – op |
| :D | | TV (fourteen) – op
MNB VPU – op |
| :E | | CAMR (six) – op |
| L9,R10 | 15. | PS,MS AUD PWR (two) – OFF |
| A13 | 16. | OS AUD SPKR PWR – OFF |
| MO42F | 17. | MIDDECK SPKR AUD SPKR PWR – OFF |
| | 18. | Call ground at every avail UHF site per COMM
POWERUP, 10-25; voice down cab temp, crew body
temps, heart rates, and words to indicate severity of cab
humidity |
- If MCC request data on cab environ or Av bays:
19. Perform CABIN ENVIRONMENT MONITOR (CONT DEORB, LOSS OF 2 H2O LOOPS), then:
- If after TIG-10 min:
20. Perform AFT PNL CONFIG FOR ENTRY COMM (CONT DEORB, LOSS OF 2 H2O LOOPS D/O PREP)

**LOSS OF 2 H2O LOOPS
ON-ORBIT
MS PAGE**

A10-24

OV103,104

OPCL/ALL/GEN M,3

NOTE
KEEP THIS PAGE UNTIL TOUCHDOWN

COMM POWERUP (If comm reqd prior to landing site coverage)

- Pwr up audio sys:
- C3 1. AUD CTR – 1
 - O5 L AUD PWR – AUD
 - O9 R AUD PWR – AUD
- If UHF avail, config for UHF comm (voice only):
- O6 2. UHF MODE sel – SPLX
√SPLX/EVA PWR AMPL – ON
 - 3. After comm with MCC complete: Go to COMM PWRDN, steps 5 thru 8, 10-23 >>
- If UHF site unavail or if MCC requests data (config for GSTDN(SGLS) S-BD):
- C3 4. √S-BD PM CNTL – PNL
 - A1L ANT SW ELEC – 2
MODE sel – STDN LO(SGLS)
XPNDR – 2
 - 5. NSP PWR – 2
√DATA RATE XMIT – HI
√RCV – HI
CODING XMIT – OFF
RCV – OFF
√UPLK DATA – S-BD
 - C3/F9 6. Sel best S-BD PM ANT
- If MCC requests data:
- O15:B : 7. cb MNB OI SIG CONDR OF 1/4 B,2/3 A
: (two) – cl
 - O14:B : 8. cb MNA OI MDM OF 1/2 A,3/4 A (two) – cl
 - C3 : 9. OI PCMMU PWR – 1
 - O6 : 10. MDM PL2 – ON
 - : 11. BFS, GNC I/O RESET
 - : At end of data transmission:
 - O14:B : 12. cb MNA OI MDM OF 1/2 A,3/4 A (two) – op
 - O15:B : 13. cb MNB OI SIG CONDR OF 1/4 B,2/3 A
: (two) – op
 - : If not reqd for PLBD CLOSURE:
 - O6 : 14. MDM PL2 – OFF
 - : After comm/data complete:
 - L 15. Go to COMM PWRDN, 10-23 >>

Cont next page

**LOSS OF 2 H2O LOOPS
ON-ORBIT
MS PAGE**

OV103,104

A10-25

OPCL/ALL/GEN M

NOTE
KEEP THIS PAGE UNTIL TOUCHDOWN

~
If UHF site and GSTDN unavail and comm/data critical:
Config for TDRS S-BD during AOS

CAUTION

This is a High Power Mode. On-time should be limited to 10 min max due to Pwr Amp Thermal constraints. A 3-min delay occurs before Pwr Amp comes on. Uplink not aff. Proceed with sel of best S-BD PM ANT

- | | |
|-----------|---|
| C3
A1L | 16. √S-BD PM CNTL – PNL
ANT SW ELEC – 2
PRE AMP – 2
PWR AMPL OPER – 2
MODE sel – TDRS DATA
XPNDR – 2 |
| | 17. NSP PWR – 2
√DATA RATE XMIT – HI
√RCV – HI
CODING XMIT – ON
RCV – ON
√UPLK DATA – S-BD |
| C3/F9 | 18. Sel best S-BD PM ANT |
| | If MCC requests data: |
| O15:B | : 19. cb MNB OI SIG CONDR OF 1/4 B,2/3 A
: (two) – cl |
| O14:B | : 20. cb MNA OI MDM OF 1/2 A,3/4 A (two) – cl |
| C3 | : 21. OI PCMMU PWR – 1 |
| O6 | : 22. MDM PL2 – ON
: 23. BFS, GNC I/O RESET |
| | : At end of data transmission: |
| O15:B | : 24. cb MNB OI SIG CONDR OF 1/4 B,2/3 A
: (two) – op |
| O14:B | : 25. cb MNA OI MDM OF 1/2 A,3/4 A (two) – op |
| | : If not reqd for PLBD CLOSURE: |
| O6 | L 26. MDM PL2 – OFF |
| | After comm/data complete: |
| | 27. Go to COMM PWRDN, 10-23 |

**LOSS OF 2 H2O LOOPS
ON-ORBIT
MS PAGE**

A10-26

OV103,104

OPCL/ALL/GEN M

LOSS OF CAB PRESS

CDR Perform JOINT EXPEDITED UNDOCKING AND SEPARATION (SODF: JOINT OPS)
MS1,MS2 Perform procs on 10-30
PLT Perform following pwrdrn

NOTE

Cab press will stabilize at 8 psia for following EQ dP/dT values:

- < 0.6 for Orbiter + Airlock
- < 0.4 for Orbiter + Airlock + Spacehab.

If docked to ISS, undocking will be performed with Single G2 (i.e., no +Z redundancy)

- C3
1. MSTR MADS PWR – OFF
 2. Minimize ltg
 3. Use one IDP/CRT with two MDUs, as reqd (IDP4 preferable)
 4. Use one PGSC, FLT CNTLR PWR as reqd
- If FLT CNTLR PWR not reqd:
- O14,O15,
O16:E
5. cb DDU L,R,AFT (six) – op
- O7
6. √TACAN MODE sel (three) – OFF
- O8
7. √MLS (three) – OFF
 - √RDR ALTM (two) – OFF
- L1
8. CAB TEMP CNTLR – OFF
 9. HUM SEP (two) – OFF
 10. H2O LOOP 2(1) BYP MODE – MAN
MAN – DECR (30 sec)
 11. √FLOW PROP VLV LOOP tb (two) – ICH
- If FES not ena:
- : If EVAP OUT T 41 to 47 degF:
 - : | 12. RAD CNTLR OUT TEMP – HI
 - : | When EVAP OUT T > 50 degF:
 - : | 13. FLASH EVAP CNTLR PRI A(B) – ON, then
 - : | immed:
 - : | 14. RAD CNTLR OUT TEMP – NORM
 - : | If EVAP OUT T < 41 or > 47 degF:
 - : | 15. FLASH EVAP CNTLR PRI A(B) – ON
- L
16. √ANTISKID – OFF
- L2
17. √NWS – OFF
- L4:L
17. cb ΦA CAB T CNTLR 1,2 (two) – op

Cont next page

OV103,104

A10-27

OPCL/3,4/GEN M

If orbit 2,3 deorbit due to cab leak:

18. Use DEORB PREP/ENTRY DELTAS PULLOUT PAGE, 10-31, then go to LAUNCH DAY DEORB PREP (ORBIT 2(3)) (CONT DEORB, LAUNCH DAY ORBIT 2(3)) >>

If orbit 3 deorbit due to fire, tox spill, or glass in cabin:

19. Go to LAUNCH DAY DEORB PREP (ORBIT 3) (CONT DEORB, LAUNCH DAY ORBIT 3) >>
- W1-10 20. Install Window Shades (ten) or mnvr to tail Sun att:
GNC UNIV PTG

TGT ID - ITEM 8 +4 EXEC
BODY VECT - ITEM 14 +5 EXEC
P - ITEM 15 +1 8 4 EXEC
Y - ITEM 16 +0 EXEC
OM - blank (MCC-provided if reqd)
DAP: A/AUTO/VERN
START TRK - ITEM 19 EXEC

C3
CRT

If time to TIG < 4 hr:

21. Go to 8 PSI DEORB PREP (DEORB PREP, CONTINGENCY DELTAS) >>

If time to TIG > 4 hr:

If currently in single G2 GPC OPS:

22. Perform G2 SET EXPANSION, target Dual G2 (ORB OPS, DPS), then:

Cont next page

OV103,104

A10-28

OPCL/ALL/GEN M,1

REASSIGN STRINGS TO GPC 2 IN MC 2

NOTE

If Av Bay 2 fire and TIG > 4 hr:
Reassign strings to GPC in unaffected
Av Bay

- CRT
O6
23. GNC 0 GPC MEMORY
CONFIG – ITEM 1 +2 EXEC
Modify MC 2 per table----->
DOWNLIST GPC –
ITEM 44 +2 EXEC
- | | |
|--------|-------|
| CONFIG | 2 |
| GPC | 02000 |
| STR 1 | 2 |
| 2 | 2 |
| 3 | 2 |
| 4 | 2 |
| PL 1/2 | 0 |
| CRT 1 | 2 |
| 2 | 2 |
| 3 | 0 |
| 4 | 2 |
| L 1 | 0 |
| 2 | 0 |
| MM 1 | 2 |
| 2 | 2 |
24. GNC, OPS 201 PRO
25. GPC MODE 1(3) – STBY
– HALT
– STBY
(tb-RUN)
– HALT
(tb-bp)
PWR 1(3) – OFF
√MODE 3,5 (two) –
HALT (tb-bp)
26. Go to 8 PSI DEORBIT PREP (DEORB PREP,
CONTINGENCY DELTAS)

DEORB PREP/ENTRY DELTAS PULLOUT PAGE

NOTE

Incorporate following changes or remove this page for use with the indicated checklist or cue card.

Single fault tolerance used for most cab air-cooled equipment. Add'l LRUs may be activated if reqd and if CAB PRESS stable ≥ 8 psia

A. Deltas to the LAUNCH DAY ORBIT 2(3) (CONT DEORB)

1. Minimize use of IDPs, MDUs, FLT CNTLR PWR, DDUs. Use one PGSC

If rev 2:

2. APU HTRS & DED DISP ENT CONFIG 3
Do not pwr TACANs

If rev 3:

3. ENT FWD FLT DECK CONFIG 10
Do not pwr MLS, TACANs
4. In ENT SW LIST/VER, do not activate pwrn items

B. Deltas to DEORBIT BURN (ENT)

At TIG-4:

1. Use two IDP/CRTs with four MDUs as reqd for deorbit burn
2. cb DDU L,R (four) – cl
3. L,R FLT CNTLR PWR (two) – ON

O14,O15,
O16:E
F6,F8

C. Deltas to POST BURN (ENT)

1. Use one IDP/CRT with two MDUs as reqd
2. L,R FLT CNTLR PWR (two) – OFF
3. cb DDU L,R,AFT (six) – op
4. Delete ANTISKID, NWS callouts (ENTRY SW CHECK)

F6,F8
O14,O15,
O16:E

Cont next page

OV103,104

**LOSS OF CAB PRESS
D/O PULLOUT PAGE**

A10-31

OPCL/3,4/GEN M

D. Deltas to ENTRY MANEUVERS (Cue Card)

At EI:

- 1. Use two IDP/CRTs with four MDUs as reqd
- 2. cb DDU L,R (four) – cl
- 3. L,R FLT CNTLR PWR (two) – ON
- 4. cb ADTA 1,2,3 (three) – cl
- 5. BFS, GNC I/O RESET

At V = 15K:

If CAB P < 8 psia:

- 6. Delete NAV AIDS callout

If CAB P ≥ 8 psia:

- 7. Activate all TACANs, RAs, MLSs
GNC I/O RESET

At M < 1.0, go to step 11

At V = 10K:

- 8. TACAN 2,3 MODE sel (two) – GPC

At M = 2.7:

- 9. Use two HUDs, MLSs, and RAs as reqd
- 10. GNC I/O RESET

At M < 1.0:

- 11. ANTISKID – ON
- 12. NWS – 1

LOSS OF HI LOAD EVAP

NOTE

MAL, ECLS SSR-2, FES CORE FLUSH PROCEDURE should be performed if core icing is suspected. If unsuccessful, perform pwrn prior to RAD BYPASS at TIG-2:50 during deorb prep. If already in deorb prep, perform pwrn and review activities already performed for changes

- C3 1. √MSTR MADS PWR – OFF
- 2. Minimize Itg
- 3. Use one IDP/CRT with two MDUs, one FLT CNTLR PWR, and one PGSC as reqd
- 4. Perform PL PWRDN, then:
- O7 5. √TACAN MODE sel (three) – OFF
- O8 6. √RDR ALTM (two) – OFF
- 7. √MLS (three) – OFF
- L1 8. √FLOW PROP VLV LOOP tb (two) – ICH
- 9. √HI LOAD DUCT HTR sel – OFF
- A3 10. TV MON (two) – OFF
- If FLT CNTLR PWR not reqd:
- O14,O15, 11. cb DDU L,R,AFT (six) – op
- O16:E
- 12. Reset EVAP OUT T C&W upper limit (ch 107,117) to 2.15V (70 degF). Change B/U C&W parameter, 0631207, 0631407 upper limit to 70
- A. Deltas to NOMINAL DEORBIT PREP (DEORB PREP) if not already performed
- At TIG-03:00, prior to RAD BYP:
- L1 1. H2O LOOP 2(1) BYP MODE – MAN
MAN – DECR (hold 30 sec)
FLASH EVAP CNTLR PRI A – OFF
B – OFF
SEC – ON
- √HI LOAD EVAP – OFF
- Perform RAD BYPASS/FES C/O (ORB OPS, ECLS):
Delete steps 3 and 5 thru 8 (SEC FES C/O)
- At TIG-03:15 in DED DISP ENT CONFIG:
- 2. Do not pwr NAV/LDG AIDS, ADTAs
Pwr DDUs, MDUs only as reqd

Cont next page

OV103,104

A10-33

OPCL/3,4/GEN M

At TIG-01:50, ENT SWITCH LIST/VERIF:

3. Do not pwr NAVAIDS, ADTAs
Delete BRAKE/ANTISKID ACT
4. Go to LOSS OF HI LOAD EVAP DEORB OR
ENTRY PULLOUT PAGE (ENT PKT, PWRDN)

B. Deltas to DEORBIT BURN (ENT)

At TIG-10:

- O14,O15,
O16:E
1. cb DDU L,R (four) – cl
 2. Use two IDP/CRTs with four MDUs, and two FLT
CNTLR PWR for burn

At TIG-5:

- L1
3. TOP EVAP HTR NOZ (two) – OFF
DUCT sel – OFF

C. Deltas to POST BURN (ENT)

- F6,F8
O14,O15,
O16:E
1. L,R FLT CNTLR PWR (two) – OFF
 2. cb DDU L,R (four) – op (save for entry)
 3. Use one IDP/CRT with two MDUs
 4. Delete ANTISKID, NWS callouts (ENTRY SW
CHECK)

D. Deltas to ENTRY MANEUVERS (Cue Card)

At EI:

- O14,O15,
O16:E
F6
1. cb DDU L,R (four) – cl
 2. L FLT CNTLR PWR – ON
 3. Use two IDP/CRTs with four MDUs
 4. BRAKES (three) – ON
- O14,O15,
O16:A
O14,O15,
O16:E
5. cb ADTA 1,2,3 (three) – cl
 6. GNC I/O RESET
 7. NWS – 1
 8. ANTISKID – ON

At V = 15K:

- O7
9. Delete NAVAIDS callout
 10. TACAN 2,3 MODE sel (two) – GPC

At M = 2.7:

11. Use two HUDs, MLSs, and RAs
12. GNC I/O RESET

OV103,104

A10-34

OPCL/3,4/GEN M

LOSS OF 1 FREON LOOP

- MS Perform MS PWRDN, 10-36
- C3
1. MSTR MADS PWR – OFF
 2. Minimize Itg
 3. Use one IDP/CRT with two MDUs as reqd, and one PGSC
- If FLT CNTLR PWR not reqd:
- O14,O15,
O16:E
4. cb DDU L,R,AFT (six) – op
- L1
5. If reqd, perform PL PWRDN, then:
 6. √FLOW PROP VLV LOOP tb (two) – ICH
 7. H2O LOOP 2(1) BYP MODE – MAN
MAN – DECR (hold 30 sec)
- SM SYS SUMM 2**
- If EVAP OUT T not ~39 degF and stable:
8. Perform TOPPING FES STARTUP (ORB OPS, ECLS), then:
- If prior to deorb prep:
- If dual or triple G2:
9. Perform G2 SET CONTRACTION (ORB OPS, DPS) to single G2, then:
- O15:F
W1-10
10. MMU 2 – OFF
 11. Mnvr to shade windows from sun or install Window Shades
- SM SYS SUMM 1**
12. Check kW; if >14 kW: Perform PRIOR PWRDN (numbered) (except FES and one PGSC) until ≤ 14 kW, then:
 13. Use UNDOCKING/DEORB/ENTRY DELTAS PULLOUT PAGE, 10-37, for changes to UNDOCKING/DEORB PREP and ENT >>
- If in deorb prep:
- F6,F8
14. √FLT CNTLR PWR (two) – OFF
 15. Use one IDP/CRT with two MDUs, as reqd
- O7
16. TACAN MODE sel (three) – OFF
- O8
17. RDR ALTM (two) – OFF
 18. MLS (three) – OFF
- L2
19. ANTISKID – OFF
NWS – OFF
 20. Continue with DEORB PREP; use UNDOCKING/DEORB/ENTRY DELTAS PULLOUT PAGE, 10-37, for changes

OV103,104

A10-35

OPCL/3,4/GEN M

MS PWRDN

1. Minimize Itg on Aft Flt Deck and Middeck
 - R14:D 2. cb TV (fifteen) – op
 - :E 3. CAMR (six) – op
 - A3 4. MON 1,2 PWR (two) – OFF
- If in deorb prep:
- O14,O15, 5. BRAKES (three) – OFF
 - O16:A
 - O14,O15, 6. cb ADTA (four) – op
 - O16:E

OV103,104

A10-36

OPCL/ALL/GEN M,6

UNDOCKING/DEORB/ENTRY DELTAS PULLOUT PAGE

NOTE

KEEP THIS PAGE UNTIL TOUCHDOWN.

Incorporate following changes or remove these pages for use with the indicated checklist or cue card.

Undocking from ISS will be performed with Single G2 (i.e., no +Z redundancy)

Perform NOMINAL DEORBIT PREP (DEORB PREP) with the following contingency deltas to the procedure

A. Deltas to DEORB PREP

1. Use one FLT CNTLR PWR, DDU, PGSC, and one IDP/CRT with two MDUs, as reqd
2. Minimize Itg
3. Minimize sun in cab if possible

If rev 3 deorb, deltas to LAUNCH DAY ORBIT 3 (CONT DEORB):

4. ENT FWD FLT DECK CONFIG **10**
Do not pwr MLS,TACANs

If nominal deorb prep:

Deltas to NOMINAL DEORBIT PREP (DEORB PREP):

5. Verify steps 14 thru 20, 10-35, MS, steps 7,8, 10-36
6. DED DISP ENT CONFIG **6**
Do not pwr ADTAs,TACANs
Add: Pwr NAV/LDG AIDS per ENTRY MANEUVERS (Cue Card)
Minimize MDU use
7. ENT SWITCH LIST/VERIF
Do not pwr LRUs previously pwr dn

B. Deltas to DEORBIT BURN (ENT)

1. Maintain window shading att until TIG-15

At TIG-15:

2. Remove Window Shades if installed

At TIG-10:

3. cb DDU L,R (four) – cl
4. Use two IDP/CRTs with four MDUs, two FLT CNTLR PWR for burn

Cont next page

OV103,104

**LOSS OF 1 FREON LOOP
PULLOUT PAGE**

A10-37

OPCL/3,4/GEN M

- F6,F8
O14,O15,
O16:E
- C. Deltas to POST BURN (ENT)
1. L,R FLT CNTLR PWR (two) – OFF
 2. cb DDU L,R (four) – op
 3. Use one IDP/CRT with two MDUs
 4. Delete ANTISKID, NWS callouts (ENTRY SW CHECK)
- O14,O15,
O16:E
F6
- D. Deltas to ENTRY MANEUVERS (Cue Card)
- At EI:
1. cb DDU L,R (four) – cl
 2. L FLT CNTLR PWR – ON
 3. Use two IDP/CRTs with four MDUs
 4. BRAKES (three) – ON
- O14,O15,
O16:A
O14,O15,
O16:E
- cb ADTA 1,2,3 (three) – cl
- L2
- GNC I/O RESET
ANTISKID – ON
NWS – 1
- At V = 15K:
- O7
5. Delete NAVAIDS callout
TACAN MODE sel (two) – GPC
- At V = 12K:
6. Perform RAD FLOW in unfailed loop
- At M = 2.7:
7. Use two HUDs, MLSs, and RAs
GNC I/O RESET
- E. Deltas to POST LDG (ENT)
- If EVAP OUT T high and incr, go to EMER PWRDN (Cue Card)
- F. Deltas to EVAP OUT TEMP HIGH (Cue Card)
- If EVAP OUT T HIGH and V > 12K:
- L1
- Establish RAD FLOW in unaff loop:
1. RAD BYP VLV MODE 1(2) – AUTO
CNTLR LOOP 1(2) – AUTO A(B)
 2. Perform EVAP OUT T HIGH (Rads Coldsoaked), steps 2 thru 4
- If EVAP OUT T HIGH and V < 12K:
- If loop 1(2) lost:
- L1
3. NH3 CNTLR B(A) – PRI/GPC

LOSS OF 1 FC

- If before deorb prep:
- L1 1. $\sqrt{\text{CAB FAN A(B) - ON}}$
- If total Orb kW > 18:
- 2. Perform PRIOR PWRDN, GROUP 1,2 (except FES), then:
 - 3. Perform PL PWRDN
- If FC 1 or 2 failed:
- R1 4. $\sqrt{\text{MN BUS TIE A,B (two) - ON}}$
 $\sqrt{\text{C - OFF}}$
- If FC 3 failed:
- 5. PL PRI MNB – ON
MNC – OFF
FC3 – OFF
 - 6. $\sqrt{\text{MN BUS TIE C,A (two) - ON}}$
 $\sqrt{\text{B - OFF}}$
- If any FC AMPS > 330 or $\Delta\text{AMPS} > 100$:
- 7. Perform MAL, EPS SSR-8, BUS LOADING – LRU SELECT, then:
 - 8. Go to step 18
- If in deorb prep:
- 9. Minimize Itg
 - 10. Use only one DDU, and FLT CNTLR PWR as reqd.
One IDP/CRT off as reqd
 - O7 11. TACAN MODE sel (three) – OFF
 - O8 12. RDR ALTM (two) – OFF
 - 13. MLS (three) – OFF
 - L1 14. $\sqrt{\text{CAB FAN A(B) - ON}}$
 - R14:D 15. cb TV (fifteen) – op
:E CAMR (six) – op
 - A3 16. MON 1,2 PWR (two) – OFF
 - A11 17. CRYO TK HTR (four) – OFF
- If FC recoverable:
- 18. Go to MAL, EPS SSR-3, FC SHUTDN C&W LIMIT CHANGE >>
- If FC unrecoverable:
- 19. Make FDF Delta changes as given (next page), then as time permits reconfig C/W limits per MAL, EPS SSR-3, FC SHUTDN C&W LIMIT CHANGE

Cont next page

OV103,104

A10-39

OPCL/3,4/GEN M,3

FDf changes:

- A. Deltas to DEORBIT BURN (ENT)
TIG-5:
- L1 1. TOP EVAP HTR NOZ (two) – OFF
DUCT sel – OFF
HI LOAD DUCT HTR sel – OFF
HUM SEP (two) – OFF
- L2 FLASH EVAP FDLN HTR SPLY (two) – OFF
- B. Deltas to EPS procs in this book
1. FC REACTANT VLV CLOSED: Delete step 6;
Change step 2 to read:
If aff FC/MN bus tied and COOL P > 40:
 2. MN BUS TIE (three) – ON (ASAP)
(Aff) MN BUS TIE (one) – OFF (ASAP)
 2. FC COOL P: Delete step 1
 3. BUS TIE, steps 1,7: Delete '(A to...A)'
 4. FC1(2,3) H2 PUMP $\uparrow\downarrow$: Replace step 3 with:
If aff FC/MN bus tied:
 3. MN BUS TIE (three) – ON
(Aff) MN BUS TIE (one) – OFF
 5. FC SAFING: Replace steps 7,8 with:
If aff FC/MN bus tied:
 7. MN BUS TIE (three) – ON
 8. (Aff) MN BUS TIE (one) – OFF
 6. FC H2O RLF NOZ TEMP $\uparrow\downarrow$: Replace step 3 with:
If aff FC/MN bus tied:
 3. MN BUS TIE (three) – ON
(Aff) MN BUS TIE (one) – OFF
 7. FC DELTA V 1(2,3):
Delete step 1
Add 'MN BUS TIE (three) – ON, then:' to
beginning of step 4
- C. Deltas to EPS (ENT PKT)
1. Perform LOSS OF 1 FC, part B, steps 1 thru 8 (ENT PKT, PWRDN), then:
If in deorb prep:
 2. Go/return to NOMINAL DEORBIT PREP (DEORB PREP) >>
- D. Deltas to FLIGHT PLAN at 10 min prior to 'Go to DEORB PREP', add: 'perform LOSS OF 1 FC, steps 9 thru 17 (ORB PKT, PWRDN)'

OV103,104

A10-40

OPCL/3,4/GEN M

LOSS OF 2nd FC ON-ORBIT (TIG < 4 hr)

If Rev 2,3 deorbit:

1. Go to LOSS OF 2nd FC (ASC PKT, PWRDN) >>
2. If TIG < 1.5 hr: Sel new TIG > 1.5 hr
(this pwrdn and the deorbit prep require 1.5 hr)

NOTE

Do NOT perform BUS LOSS ACTION unless bus shorted (step 29 regains bus)

- * FC capability is ~12 kW for sustained operations, *
- * ~13 kW for short duration (~4 hr), ~16 kW for *
- * contingency situations (~10 min). Purge FC at *
- * 430 amps or less *

- MS 3. Perform AFT PNL PWRDN, 10-43, immed
- C3 4. √MSTR MADS PWR – OFF
5. Minimize Itg
6. Use only one DDU, PGSC, and FLT CNTLR PWR as reqd. One IDP/CRT off as reqd
- O7 7. √TACAN MODE sel (three) – OFF
- O8 8. √RDR ALTM (two) – OFF
- MS 9. √MLS (three) – OFF

If GPC 2 on:

10. GNC 0 GPC MEMORY

CONFIG – ITEM 1 +2 EXEC

Modify MC 2 per table ---->

For any IDP that is OFF:

11. GPC/CRT1/X EXEC
- CRT 12. √DOWNLIST GPC (ITEM 44) – 1
GNC, OPS 201 PRO
- O6 13. GPC MODE 2 – STBY (tb-bp)
– HALT
PWR 2 – OFF
14. √MODE 3,5 (two) – HALT
(tb-bp)
PWR 3 – OFF
- O15:F 15. √MMU 2 – OFF

	CONFIG	2
GPC		10000
STR	1	1
	2	1
	3	1
	4	1
PL	1/2	0
CRT	1	1
	2	1
	3	0
	4	1
L	1	0
	2	0
MM	1	1
	2	1

Cont next page

OV103,104

A10-41

OPCL/3,4/GEN M

16. GNC 20 DAP CONFIG
 Sel TAIL PRI P,Y OPTION
 Sel PRI JETS
- O7 17. AFT L,R RCS MANF ISOL 4 (two) – CL
 O14,O15, 18. RJDF DRIVER (four) – OFF
 O16:F LOGIC (four) – OFF
 O6 19. MDM FF4 – OFF
 O14:F 20. RJDA 2A L4/R4 DRIVER – OFF
 LOGIC – OFF
- L1 21. $\sqrt{\text{FLOW PROP VLV LOOP tb}}$ (two) – ICH
 22. SM 88 APU/ENVIRON THERM
 23. H2O LOOP 2 BYP MODE – MAN
 MAN – INCR(DECN)
 (adjust until ICH FLOW ~950)
- If no MANF leak:
 R1 24. $\sqrt{\text{O2,H2 MANF VLV}}$ (four) – OP
 TK1 HTRS B – AUTO (MNA or MNB ↓) or
 TK2 HTRS B – AUTO (MNC or no
 MN BUS ↓), then:
 All others OFF
- If MANF leak:
 25. $\sqrt{\text{O2/H2 HTR LOSS TABLE (EPS)}}$, 5-20
 Sel one htr in one O2,H2 TK
- R2 26. HYD CIRC PUMP (three) – OFF
 L4:L 27. cb AC1,2 Φ A CAB T CNTLR 1,2 (two) – op
 If not MN bus short, tie three MN BUSES:
 28. Perform BUS TIE (Cue Card), then:
 Post BUS TIE config check:
- L1 29. $\sqrt{\text{CAB FAN A(B)}}$ – ON
 30. Perform RCS SECURE, FWD RCS only (RCS), 8-2,
 then:
 31. Perform MAL, EPS SSR-3, FC SHUTDN C&W LIMIT
 CHANGE, then:
 32. Go to LOSS OF 2 FC (CONT DEORB). Refer to
 Activities Priority Table for activities to be performed in
 the CONT DEORB

OV103,104

A10-42

OPCL/ALL/GEN M

AFT PNL PWRDN

- A11 1. CRYO TK HTR (four) – OFF
- A12 2. APU HTR LUBE OIL LN (three) – OFF
- 3. HYD HTR (eight) – OFF
- A14 4. RCS/OMS HTR FWD RCS – OFF
- 5. RCS JET (five) – OFF
- 5. Perform PL SAFING, then:

CAUTION
If stow prob occurs with either RMS and/or
KU-BD ANT, perform aff sys QUICK
RESPONSE JETTISON (CONT DEORB)

If RMS grappled to OBSS:

- 6. Perform OBSS JETTISON (PDRS OPS FS,
OBSS CONTINGENCY), then:

If RMS-only:

- 7. Perform RMS PWRDN (PDRS OPS), then:

If KU-BD ANT deployed:

- 8. Perform KU-BD ANT STOW (ORB OPS,
COMM/INST), then:

If radiators deployed:

- 9. Perform RAD STOW (ORB OPS, ECLS), then:

- A3 10. MON PWR (two) – OFF
- R14:D 11. cb TV (fifteen) – op
- :E CAMR (six) – op
- ML86B:C 12. √cb MNB EXT AIRLK HTR VEST Z1/2/3 – op

If MMU is pwr:

- :D 13. cb MNA MMU PORT HTR A – op
- STBD HTR A – op
- MNB MMU PORT HTR B – op
- STBD HTR B – op

- MD44F 14. Cab temp cntl act link – pin to FULL COOL

**LOSS OF 2nd FC
ON-ORBIT (TIG < 4 hr)
MS PAGE**

A10-43

OV103,104

OPCL/ALL/GEN M,6

This Page Intentionally Blank

**LOSS OF 2nd FC
ON-ORBIT (TIG < 4 hr)
MS PAGE**

A10-44

OV103,104

OPCL/ALL/GEN M

LOSS OF 2nd FC ON-ORBIT (TIG > 4 hr)

NOTE

Do NOT perform BUS LOSS ACTION unless bus shorted (step 8 regains bus).

If docked with ISS, perform PWRDN completely prior to undocking

- * FC capability is ~12 kW for sustained operations, *
- * ~13 kW for short duration (~4 hr), ~16 kW for *
- * contingency situations (~10 min). Purge FC at *
- * 430 amps or less *

- | | |
|-------|---|
| MS | 1. Perform MS OVHD AND AFT PNL PWRDN, 10-47, immed |
| C3 | 2. <input checked="" type="checkbox"/> MSTR MADS PWR – OFF
<u>GNC 21 IMU ALIGN</u> |
| | 3. IMU 1,2 (two) – desel |
| | If GPC 2(3) on: |
| | 4. <u>GNC 0 GPC MEMORY</u>
CONFIG – ITEM 1 +2 EXEC
Modify MC 2 per table ----> |
| | <input checked="" type="checkbox"/> DOWNLIST GPC
(ITEM 44) – 1 |
| CRT | GNC, OPS 201 PRO |
| | For any IDP that is OFF: |
| | 5. GPC/CRT1/X EXEC |
| O6 | 6. GPC MODE 2 – STBY (tb-bp)
– HALT
PWR 2 – OFF
<input checked="" type="checkbox"/> MODE 3,5 (two) – HALT
(tb-bp) |
| | <input checked="" type="checkbox"/> PWR 3 – OFF |
| O15:F | 7. MMU 2 – OFF |
| | If not MN bus short, tie three MN buses: |
| | 8. Perform BUS TIE (EPS), 5-16, then: |
| | 9. Minimize Itg |
| | 10. Use one DDU, PGSC, and FLT CNTLR PWR as reqd.
Use one IDP/CRT with four MDUs |
| O7 | 11. <input checked="" type="checkbox"/> TACAN MODE sel (three) – OFF |
| O8 | 12. <input checked="" type="checkbox"/> RDR ALTM (two) – OFF |
| | 13. <input checked="" type="checkbox"/> MLS (three) – OFF |

	CONFIG	2
	GPC	10000
STR	1	1
	2	1
	3	1
	4	1
PL	1/2	0
CRT	1	1
	2	1
	3	0
	4	1
L	1	0
	2	0
MM	1	1
	2	1

Cont next page

OV103,104

A10-45

OPCL/3,4/GEN M

- L1 14. $\sqrt{\text{FLOW PROP VLV LOOP tb (two) - ICH}}$
 15. AV BAY 2 FAN A,B (two) - OFF
 16. $\sqrt{\text{CAB FAN A(B) - ON}}$
- L4:L 17. cb AC1,2 Φ A CAB T CNTLR 1,2 (two) - op
 18. Perform GG FREE DRIFT, ATT ID B (mnvr in PRI, establish drift in VERN) (ORB OPS, RCS), then:
 If docked with ISS, have ISS establish mated att control
- O14,O15, O16:F 19. Set event timer for 30 min (for FES duct htr deact)
 O6 20. RJD LOGIC,DRIVER (seventeen) - OFF
- L1 21. MDM FF1,FF2,FF4 (three) - OFF
 FA1,FA2,FA3,FA4 (four) - OFF
 22. TOP EVAP HTR NOZ L,R (two) - OFF
 23. $\sqrt{\text{HI LOAD DUCT HTR sel - OFF}}$
 24. SM 88 APU/ENVIRON THERM
 25. H2O LOOP 2 BYP MODE - MAN
 MAN - INCR(DECR)
 (adjust until ICH FLOW ~950)
- R1 If no MANF leak:
 26. $\sqrt{\text{O}_2\text{,H}_2\text{ MANF VLV (four) - OP}}$
 TK1 HTRS B - AUTO (MNA or MNB \downarrow) or
 TK2 HTRS B - AUTO (MNC or no
 MN BUS \downarrow), then:
 All others OFF
- If MANF leak:
 27. $\sqrt{\text{O}_2\text{/H}_2\text{ HTR LOSS TABLE (EPS), 5-20}}$
 Sel one htr in one O2,H2 TK
- R2 28. BLR CNTLR/HTR (three) - OFF
 29. HYD CIRC PUMP (three) - OFF
- R4 30. Verify RMS, KU-BD ANT, and RADS stowed, then:
 MA73C:A, B MCA LOGIC (fourteen) - OFF
- :A If H2O LOOP 2 failed:
 31. MCA LOGIC MNB FWD 2 - ON
 30 min after FES deact:
- L1 32. TOP EVAP HTR DUCT sel - OFF
 33. Perform MAL, EPS SSR-3, FC SHUTDN C&W LIMIT CHANGE, then:
 If docked with ISS, perform UNDOCKING DELTAS prior to undocking
 34. Go to LOSS OF 2 FC (CONT DEORB)

OV103,104

MS OVHD AND AFT PNL PWRDN

- O14:A 1. IMU 1 – OFF (confirm IMU desel)
- O15:A 2. 2 – OFF (confirm IMU desel)
- O16:E 3. cb MNC RCS/OMS PRPLT QTY GAUGE – op
- R14:D 4. TV (fifteen) – op
- A11 5. CRYO TK HTR (four) – OFF
- A12 6. APU HTR LUBE OIL LN (three) – OFF
- 7. HYD HTR (eight) – OFF
- A14 8. RCS/OMS HTR FWD RCS JET 1,2,3,4 (four) – OFF
- ML31C 9. VAC VENT NOZ HTR – OFF
- ML86B:A 10. cb MNA H2O LN HTR A – op
- 11. MNB H2O LN HTR B – op
- :C 12. √cb MNB EXT AIRLK HTR VEST Z1/2/3 – op
- If MMU is pwrd:
- :D 13. cb MNA MMU PORT HTR A – op
- STBD HTR A – op
- MNB MMU PORT HTR B – op
- STBD HTR B – op
- MD44F 14. Cab temp cntl act link – pin to FULL COOL
- 15. Perform PL SAFING, then:

CAUTION
If stow prob occurs with either RMS and/or
KU-BD ANT, perform aff sys QUICK
RESPONSE JETTISON (CONT DEORB)

If RMS grappled to OBSS:

- 16. Berth OBSS or perform OBSS JETTISON (PDRS OPS FS, OBSS CONTINGENCY), then:

If RMS-only:

- 17. Perform RMS PWRDN (PDRS OPS), then:

If KU-BD ANT deployed:

- 18. Perform KU-BD ANT STOW (ORB OPS, COMM/INST), then:

If radiators deployed:

- 19. Perform RAD STOW (ORB OPS, ECLS), then:

20. Report to CDR: RMS, KU-BD ANT, and RADS stowed

- O14:F 21. MMU 1 – OFF
- R14:E 22. cb CAMR (six) – op
- A3 23. MON PWR (two) – OFF

**LOSS OF 2nd FC
ON-ORBIT (TIG > 4 hr)
MS PAGE**

A10-47

OV103,104

OPCL/ALL/GEN M,6

UNDOCKING DELTAS

NOTE

Following steps reqd to recover RCS
functionality prior to undock

- | | | |
|----------|----|---|
| | 1. | One hour prior to undock: |
| A14 | | RCS/OMS HTR FWD RCS JET 1,2,3,4 (four) – ON |
| O14,O15, | 2. | RJD LOGIC,DRIVER (seventeen) – ON |
| O16:F | | |
| O6 | 3. | MDM FF1,FF2,FA1,FA2 (four) – ON |

After undocking complete and post Final Sep:

- | | | |
|----------|----|---|
| | 4. | Perform GG FREE DRIFT, ATT ID B (mnvr in PRI.
Establish drift in VERN) (ORB OPS, <u>RCS</u>), then: |
| O14,O15, | 5. | RJD LOGIC,DRIVER (seventeen) – OFF |
| O16:F | | |
| O6 | 6. | MDM FF1,FF2,FA1,FA2 (four) – OFF |
| A14 | 7. | RCS/OMS HTR FWD RCS JET 1,2,3,4 (four) – OFF |

LOSS OF 2nd FC
ON-ORBIT (TIG > 4 hr)
MS PAGE

A10-48

OV103,104

OPCL/ALL/GEN M

LOSS OF 2 FREON LOOPS

WARNING

FC purge must be started and loads pwr'd dn ASAP

Orbiter lifetime is expected to be 120 min from LOSS OF 2nd FREON LOOP with all three FCs running. This assumes three FCs are pwr'd dn to a total level of 8 kW immed and are continuously purged

Earliest possible landing is req'd

NOTES

- Failure assumed to occur after GO for On-orbit and before Deorbit TIG-2:05
- COMM procs, 10-65 thru 10-68, should be used throughout this proc and CONT DEORB
- Preferred comm config is:
 - A. UHF only
 - B. GSTDN S-BD if req'd
 - C. TDRS only if mandatory
- If docked to ISS, this proc is to be worked simo with JOINT EXPEDITED UNDOCKING AND SEPARATION (SODF: JOINT OPS)

Cont next page

A10-49

OV103,104

OPCL/ALL/GEN M

TIME CRITICAL PROCEDURES

NOTE

Undocking will be performed with Single G2
(i.e., no +Z redundancy)

1. If in OPS 1: Go to LOSS OF 2 FREON LOOPS (POST OMS-2)
(ASC PKT, PWRDN) >>
2. Have CDR perform JOINT EXPEDITED UNDOCKING AND SEPARATION (SODF: JOINT OPS)
3. Have MS exec RAD STOW, KU-BD ANT STOW, and PLBD CLOSE, 10-57, ASAP
4. Have second MS exec RMS STOW and MS OVHD AND AFT PNL CONFIG, 10-59 thru 10-62, ASAP
5. Have third MS exec COMM PWRDN, 10-65; delay 10 min max if AOS

Perform following steps ASAP:

O14,O15, 6. $\sqrt{\text{Pri}}$ RJD LOGIC,DRIVER (sixteen) – ON
O16:F

DAP: ALT (this proc results in loss of VERNs)

O16:F RJD MANF L5/F5/R5 DRIVER – OFF

7. Record MET of failure of 2nd FREON LOOP:

_____/_____:_____:_____

C3 8. MSTR MADS PWR – OFF

MS R11U 9. $\sqrt{\text{FC}}$ PURGE HTR – ON

10. $\sqrt{\text{VLVS}}$ 1,2,3 (three) – OP

11. Minimize Itg

CRTX 12. Use only one fwd IDP/CRT with one MDU (save IDP3 for entry)

13. Use only one PGSC

F6/F8 14. $\sqrt{\text{FLT}}$ CNTLR PWR (two) – OFF, as reqd

Cont next page

OV103,104

A10-50

OPCL/ALL/GEN M

Config GPC 1 to MC 2:

15. GNC 0 GPC MEMORY
16. CONFIG – ITEM 1 +2 EXEC
- If not GNC 201, then:
17. GNC, OPS 201 PRO
18. Modify MC 2 per table

CONFIG	2
GPC	10000
STR 1	1
2	1
3	1
4	1
PL 1/2	0
CRT 1	1
2	1
3	0
4	1
L 1	0
2	0
MM 1	1
2	1

NOTE

The following must be an OPS mode recall:
GNC, OPS 201 PRO

For any IDP that is OFF:

19. GPC/CRT1/X EXEC
20. \sqrt BFC CRT DISP – OFF
21. GPC MODE 2,3 (two) – STBY (tb-bp), HALT
– STBY (tb-RUN)
– HALT (tb-bp)
PWR 2,3 (two) – OFF
MODE 5 – STBY (tb-RUN)
– HALT (tb-bp)
OUTPUT 5 – NORM
PWR 5 – OFF
22. \sqrt TACAN MODE sel (three) – OFF
23. \sqrt RDR ALTM (two) – OFF
24. \sqrt MLS (three) – OFF
25. FCS CH (four) – AUTO
26. MPS MANF PRESS (two) – CL
27. HYD CIRC PUMP (three) – OFF
28. MPS He ISOL (six) – CL
PNEU He ISOL – CL
L ENG He XOVR – CL
29. HUM SEP (two) – OFF
30. \sqrt IMU FAN B – ON
A,C (two) – OFF

C3
O6

O7
O8

C3
R4
R2

L1

Cont next page

OV103,104

A10-51

OPCL/3,4 /GEN M

- MD44F 31. Cab temp cntl act link – pin to FULL COOL
L1 32. CAB FAN A,B (two) – OFF
33. √AV BAY 1 FAN A – OFF
√2,3 FAN A,B (four) – OFF
√1 FAN B – ON
34. FREON PUMP LOOP 1,2 (two) – OFF (one-ON,
if any flow)
35. RAD CNTLR LOOP 1,2 (two) – OFF
36. √NH3 CNTLR A,B (two) – OFF
If no FREON PUMPS ON, then:
L2 37. O2 SYS 1,2 SPLY (two) – OP (tb-OP)
L1 38. FLASH EVAP CNTLR PRI A,B (two) – OFF
TOP EVAP HTR NOZ (two) – OFF
DUCT sel – OFF
L2 39. HI LOAD DUCT HTR sel – OFF
40. FLASH EVAP FDLN HTR SPLY (two) – OFF
If one FREON PUMP ON:
L1 41. FLASH EVAP CNTLR PRI A – ON
42. TOP EVAP HTR NOZ (two) – OFF
√DUCT sel – ON
L2 43. √HI LOAD DUCT HTR sel – ON
44. FLASH EVAP FDLN HTR B SPLY – OFF
45. √ANTISKID – OFF
46. √NWS – OFF
O6 47. S TRK PWR -Y,-Z (two) – OFF
48. ANNUN BUS SEL ACA 2/3 – OFF
GNC 21 IMU ALIGN
49. IMU 1,2 (two) – desel
– OFF
O14,
O15:A
- CAUTION**
Do not perform steps 50 thru 56
until PLBDs are closed
- C2 50. IDP/CRT MAJ FUNC (three) – GNC
O6 51. GPC MODE 4 – STBY (tb-bp)
– HALT
PWR 4 – OFF
GNC 0 GPC MEMORY
52. CONFIG – ITEM 1 +2 EXEC
53. Assign PL1/2 to GPC 1 (provides Uplk path)
54. GNC, OPS 201 PRO

Cont next page

OV103,104

A10-52

OPCL/ALL/GEN M

- 55. All IDPs,MDUs – OFF (use one IDP/CRT with one MDU as reqd until CONT DEORB proc, 3 min OFF for each min ON)
- O6 56. MDM FF1,4 (two) – OFF
FA1,4 (two) – OFF
- F6 57. CDR disp sws – green dot

NOTE

If no site avail, bailout will be reqd; TIG will = MET of 2nd FREON LOOP failure + 1 hr

- 58. Sel ELS TIG \leq 1 hr after MET of 2nd FREON LOOP failure (from MCC or PGSC):
 - Selected TIG : : : MET
 - (-) Present TIME : : : MET
 - (=) Time to TIG : : : MET

If PL MDMs not currently being used for comm:

- 59. Verify PLBDs are closed, then:
 - √MDM PL1,PL2 (two) – OFF
- O6 60. cb AC3 Φ A SIG CONDR HUM SEP – op
L4:J Φ B SIG CONDR IMU FAN – op
- :L 61. AC1 Φ A CAB T CNTLR 2 – op
 Φ B AV BAY 2 S/C – op
- 62. AC2 Φ A CAB T CNTLR 1 – op
 Φ B AV BAY 3 S/C – op
- AC3 Φ A H2O CNTLR 1 – op
- R1 63. MN BUS TIE (three) – ON
- 64. √O2,H2 MANF VLV TK1,TK2 (four) – op
TK2 HTRS A,B (four) – OFF
TK1,TK3 HTRS A,B (eight) – AUTO

If O2 TK1(TK3) QTY < 80%:

- 65. O2 TK1,TK3 HTRS A (two) – OFF
- R2 66. BLR CNTLR/HTR 2 – OFF
PWR 2 – OFF

If not docked with ISS or when undocking complete and Post Final Sep:

- 67. Perform POST UNDOCKING AND FINAL SEP RECONFIG, 10-55
- 68. Go to ENTRY CONFIG (CONT DEORB, LOSS OF 2 FREON LOOPS D/O PREP) by ~ TIG-15 >>

OV103,104

A10-53

OPCL/ALL/GEN M

This Page Intentionally Blank

OV103,104

A10-54

OPCL/ALL/GEN M

POST UNDOCKING AND FINAL SEP RECONFIG

1. DAP: FREE
2. RJD LOGIC,DRIVER (seventeen) – OFF
O14,O15,
O16
3. cb MNA OI SIG CONDR OF 1/4 A – op
O14:B
4. cb MNB OI SIG CONDR OF 1/4 B – op
O15:B
5. cb MNC OI SIG CONDR OF 2/3 A – op
O16:B
6. √cb L,R,AFT DDU (six) – op
O14,O15,
O16:E

OV103,104

A10-55

OPCL/ALL/GEN M

This Page Intentionally Blank

OV103,104

A10-56

OPCL/ALL/GEN M

MS PULLOUT PAGE

MS Execute ASAP

- R11U
1. FC PURGE HTR – ON
VLVS (three) – OP
 2. Minimize ltg on Aft Flt Deck

NOTE

For following RAD STOW, KU-BAND ANT STOW, and PLBD CLOSE procs, use the following MCA config. Disregard MCA sw throws in other procs until PLB doors closed

MCA LOGIC CONFIG

- MA73C:A, 3. ✓All MCA LOGIC (fourteen) – ON
B
:A 4. MCA LOGIC MNA FWD 1 – ON
MNB FWD 2 – OFF
MID 1 – OFF
MNC FWD 3 – OFF
:B MNA AFT 1 – OFF
MNB AFT 2 – OFF
MID 3 – OFF
MNC AFT 3 – OFF
5. GNC 23 RCS
ITEM 1 EXEC (FRCS page)
OVRD FRCS MANF(s) – OP

CAUTION

If stow prob occurs with KU-BD ANT, perform QUICK RESPONSE JETTISON (CONT DEORB)

If KU-BD ANT deployed:

6. Perform KU-BD ANT STOW (ORB OPS, COMM/INST), then:

If radiators deployed:

7. Perform RAD STOW (ORB OPS, ECLS), then:

Cont next page

**LOSS OF 2 FREON LOOPS
ON-ORBIT
MS PAGE**

A10-57

OV103,104

OPCL/ALL/GEN M,6

PLBD CLOSURE

WARNING
Verify no obstructions before closing and
latching PLBD (Ku ANT,RAD,RMS,etc)

- O6 1. √MDM PL1,PL2 (two) – ON
SM I/O RESET
- CRT4 2. Verify PL SAFING complete
- CRT4 3. SM, OPS 202 PRO – close PLBD ASAP
- 4. SM PL BAY DOORS
- R13L 5. PL BAY DR SYS 1,2 (two) – ENA
- CRT4 6. AC POWER ON – ITEM 1 EXEC
AUTO MODE SEL – ITEM 3 EXEC
PBD SW BYPASS – ITEM 14 EXEC
CLOSE – ITEM 17 EXEC
- If 'PLB SEQ FAIL' msg during door closure and aft latches
: for that door are not 'CL':
: 7. Check door scallop on or below tgt line before
: continuing in MAN mode; otherwise:
: 8. Perform MAL, MECH SSR-2,
L CONTINGENCY PLBD CLOSURE, then:
9. PBD STOP – ITEM 16 EXEC
- 10. AC POWER OFF – ITEM 2 EXEC
GPC/CRT 04 EXEC
- R11L 11. IDP/CRT4 PWR – OFF
- R13L 12. PL BAY DR SYS (two) – DSBL
- A7U √FLOOD (all) – OFF
- MA73C:A, 13. All MCA LOGIC sw except MNA FWD 1 (thirteen)
B – OFF
:A √MCA LOGIC MNA FWD 1 – ON
- 14. GNC 23 RCS
ITEM 1 EXEC (FRCS page)
OVRD FRCS MANF(s) – OP
- 15. Report to CDR: RMS, KU-BD ANT, and RADS stowed;
PLBD closed
- 16. Go to FLUID LOADING PREP, 10-63

**LOSS OF 2 FREON LOOPS
ON-ORBIT
MS PAGE**

A10-58

OV103,104

OPCL/ALL/GEN M

RMS STOW

NOTE

For following RMS STOW, use following MCA config. Disregard MCA sw throws in other procs until PLB doors closed

- MA73C:A, 1. √MCA LOGIC MNA MID 1 – ON
B √3 – ON
√MNB MID 2 – ON
√4 – ON
√MNC MID 2 – ON
√4 – ON
2. Perform PL SAFING, then:

CAUTION

If stow prob occurs with RMS, perform QUICK RESPONSE JETTISON (CONT DEORB)

If RMS grappled to OBSS:

3. Perform OBSS JETTISON (PDRS OPS FS, OBSS CONTINGENCY), then:

If RMS-only:

4. Perform RMS PWRDN (PDRS OPS), then:

MS OVHD AND AFT PNL CONFIG

- O13:A 1. cb ESS 1BC C/W A – op
:B CRYO QTY O2,H2 TK2 (two) – op
:C 2CA C/W B – op
(all SM tones and C/W lights and tones lost; CRT
FAULT SUMM and SM ALERT light remains)
cb ESS 2CA MTU B – op
:E 3AB GPC STAT – op
- O14:A 2. √BRAKES MNA – OFF
3. √RGA 1 – OFF
:B 4. cb MNA OI SIG CONDR OM 1/2 A – op
MDM OF 1/2 A – op
3/4 A – op
H2O BYP LOOP 1 SNSR – op
MSN TIMER FWD – op
EVENT TIMER AFT – op

Cont next page

**LOSS OF 2 FREON LOOPS
ON-ORBIT
MS PAGE**

A10-59

OV103,104

OPCL/ALL/GEN M

- O14:C 5. cb MNA UTIL PWR O19/MO52J – op
- :D FREON RAD CNTLR 1,2 (two) – op
- O2/N2 CNTLR 1 – op (leave cl if PCS 1 active)
- CAB VENT – op
- VENT ISOL – op
- :E √ADTA 1 – op
- √ACCEL 1 – op
- DDU L,AFT (two) – op
- :F 6. MMU 1 – OFF
- 7. ASA 1 – OFF
- O15:A 8. √BRAKES MNB – OFF
- 9. √RGA 2 – OFF
- 4 – OFF
- :B 10. cb MNB OI MDM OF 1/2 B – op
- H2O BYP LOOP 2 SNSR – op
- MSN TIMER AFT – op
- EVENT TIMER FWD – op
- :C UTIL PWR F1/MO13Q – op (leave cl if
- PGSC reqd)
- :D FREON RAD CNTLR 1,2 (two) – op
- O2/N2 CNTLR 2 – op (leave cl if PCS 2 active)
- :E ADTA 2 – op
- ACCEL 2 – op
- DDU L,R (two) – op
- :F 11. MMU 2 – OFF
- 12. ASA 2 – OFF
- 13. ACCEL 4 – OFF
- O16:A 14. √BRAKES MNC – OFF
- 15. √RGA 3 – OFF
- :B 16. cb MNC OI MDM OF 3/4 B – op
- AUX TIMING BUFF – op
- :C 17. CRYO O2 HTR TK2 SNSR 1 – op
- If GALLEY:
- 18. cb MNC UTIL PWR A11/A15/MO30F – op

Cont next page

**LOSS OF 2 FREON LOOPS
ON-ORBIT
MS PAGE**

A10-60

OV103,104

OPCL/ALL/GEN M

- | | | |
|-------|------------|---------------------------------------|
| O16:C | 19. | cb MNC ANNUN AFT ACA 4/5 – op |
| | | O2 EMER – op |
| :E | | ADTA 3,4 (two) – op |
| | | DDU R,AFT (two) – op |
| | | RCS/OMS PRPLT QTY GAUGE – op |
| :F | 20. | ASA 3,4 (two) – OFF |
| | 21. | ACCEL 3 – OFF |
| O17:A | 22. | ATVC (four) – OFF |
| :B | 23. | EIU (three) – OFF |
| :C | 24. | SIG CONDR FREON A,B (two) – OFF |
| :D | | OA 1/2/3 – OFF |
| | 25. | MDM OA 1/2/3 – OFF |
| | 26. | MEC 1 – OFF, wait 2 sec, then |
| | | 2 – OFF |
| MO58F | 27. | TV PWR – OFF |
| O19 | 28. | COAS – OFF |
| A11 | 29. | CRYO TK4 HTR O2,H2 A,B (four) – OFF |
| A12 | 30. | APU HTR GAS GEN/FU PUMP 2 – OFF |
| | | LUBE OIL LN 1,2,3 (three) – OFF |
| | | APU HTR TK/FU LN/H2O SYS |
| | | 1B,2A,2B,3A (four) – OFF |
| | | 1A,3B (two) – AUTO |
| | 31. | HYD HTR (eight) – OFF |
| A13 | 32. | OS AUD SPKR PWR – OFF |
| | 33. | GPS PWR – OFF |
| | | PRE AMPL (two) – OFF |
| A14 | 34. | RCS/OMS HTR FWD RCS – OFF |
| | | L,R POD (four) – OFF |
| | | OMS CRSFD LN (two) – OFF |
| | | FWD RCS JET (five) – OFF |
| | | AFT RCS JET (five) – OFF |
| A15 | If OV-103: | |
| | 35. | PTU/MAIN BUS A,B (two) – OFF (tb-OFF) |
| A6U | 36. | FLT CNTLR PWR – OFF, as reqd |
| | 37. | ANNUN BUS SEL – OFF |

Cont next page

**LOSS OF 2 FREON LOOPS
ON-ORBIT
MS PAGE**

A10-61

OV103,104

OPCL/3,4/GEN M,2

R14:A	38.	cb MNA ADC 1A/2A – op MNB ADC 1B/2B – op
:B		MNA,MNB,MNC PALLET DSC (three) – op
:D	39.	TV (fifteen) – op
:E		CAMR (six) – op
L9,R10	40.	PS,MS AUD PWR (two) – OFF
	41.	Minimize Middeck lgt
ML31C	42.	VAC VENT NOZ HTR – OFF
ML86B:A	43.	cb MNB H2O LN HTR B – op
		If MMU is pwrd:
:D	44.	cb MNA MMU PORT HTR A – op STBD HTR A – op MNB MMU PORT HTR B – op STBD HTR B – op
MO39M	45.	MIDDECK COMM CCU PWR – OFF
MO42F		SPKR AUD PWR – OFF
		If no GALLEY:
	46.	Go to step 49
GALLEY	47.	OVEN/RHS – OFF H2O HTR (two) – OFF √OVEN FAN – OFF
	48.	Go to step 51
	49.	FOOD WARMER – OFF
	50.	H2O DISPENSER PWR pb – OFF
MD44F	51.	Cab temp cntl act link – pin to FULL COOL
MO13Q	52.	All MIDDECK lts – lt off

OV103,104

A10-62

OPCL/3,4/GEN M,3

FLUID LOADING PREP

- GALLEY
1. OVEN/RHS – ON
 2. Unstow, fill 4 water containers (per crewmember) with 8 oz of water each. Temp stow near seat
 3. Unstow 8 salt tablets (per crewmember). Temp stow in Flt Suit pocket
 4. OVEN/RHS – OFF
 5. ✓H2O HTR (two) – OFF
 6. ✓OVEN FAN – OFF
 7. Stow Personal Hygiene Hose

NOTE

Ensure sufficient containers and salt tablets are prepared to continue fluid loading thru entry

FLUID LOADING

Immed (or as soon as time permits), begin drinking H2O (one 8-oz container every 15 min with a salt tablet in every other container); continue thru entry

CLOTHING CONFIG

Don QDM for temp > 90 degF and discomfort. If cab temp > 95 degF and no evaporative cooling is sensed, don LES, check tabs, close visor, LES O2 – ON

NOTE

Inflate anti-g suit as needed for on-orbit circulatory support

FDF CONFIG

1. Unstow: ENT, ENT PKT, ENT Cue Cards
2. Use DEORBIT BURN MONITOR and ENTRY MANEUVERS Cue Card (CONT DEORB, LOSS OF 2 FREON LOOPS D/O PREP)

CAB CONFIG

1. Stow loose equipment
After Deorbit Targeting complete:
 2. Stow Backup PGSC
 3. Remove and stow Side hatch UV filter, locking device, and pyro box safing pin
 4. Tape foot loops in egress routes
 5. Remove and stow Window Shades (if not needed for cab T control)

**LOSS OF 2 FREON LOOPS
ON-ORBIT
MS PAGE**

A10-63

OV103,104

OPCL/ALL/GEN M

WCS DEACT

- | | | |
|-------|----|-------------------------------------|
| WCS | 1. | Foot Restraints – up, locked |
| ML31C | 2. | VAC VENT ISOL VLV CNTL – CL (tb-CL) |

POLE SETUP

Perform ESCAPE POLE STOWAGE/SETUP (Cue Card), then:

SEAT INSTALLATION

1. Confirm minimum lftg on Middeck
2. Unstow LOSS OF 2 FREON LOOPS D/O PREP (CONT DEORB);
perform MS PAGE procs

**LOSS OF 2 FREON LOOPS
ON-ORBIT
MS PAGE**

A10-64

OV103,104

OPCL/ALL/GEN M,6

NOTE

The COMM PWRDN and POWERUP procs on this and following pages should be used until Touchdown

COMM PWRDN

- MS Pwr dn comm ASAP after comm with MCC no longer reqd. Delay 10 min max if AOS. Use COMM POWERUP, 10-67, if MCC comm reqd. Comm will be pwrd on entry by AFT PNL CONFIG FOR ENTRY COMM, MS PULLOUT PAGE (CONT DEORB, LOSS OF 2 FREON LOOPS D/O PREP) and special ENTRY MANEUVERS Cue Card
- A1L 1. S-BD PM ANT SW ELEC – OFF
PRE AMP – OFF
PWR AMPL STBY – OFF
OPER – OFF
MODE sel – STDN LO
XPNDR – OFF
2. NSP PWR – OFF
ENCRYPTION PWR – OFF
(Encrypt disabled rest of flt)
ENCRYPTION MODE – SEL
SEL – BYP
- C3 3. S-BD PM CNTL – PNL,CMD
OI PCMMU FORMAT – FXD
PWR – OFF
AUD CTR – OFF (pwr up as reqd for cockpit audio)
- A1L 4. √S-BD PL CNTL – PNL
√PWR SYS – OFF
PL DATA INTLVR PWR – OFF
- A1R 5. S-BD FM CNTL – PNL
PWR – OFF
- A3 6. MON PWR (two) – OFF
A7U 7. TV PWR CONTR UNIT – OFF
O6 8. UHF MODE sel – OFF
9. MDM PL1,PL2 (two) – OFF
R12L 10. VTR PWR – OFF
R14:B 11. cb MNA,MNC GCILC (two) – op

Cont next page

**LOSS OF 2 FREON LOOPS
ON-ORBIT
MS COMM PAGE**

A10-65

OV103,104

OPCL/ALL/GEN M

NOTE

During each comm window, voice down cab temp, crew body temps and heart rates, per COMM POWERUP, 10-67; indicate severity of cab humidity

If after TIG-10:

12. Go to AFT PNL CONFIG FOR ENTRY COMM, MS PULLOUT PAGE (CONT DEORB, LOSS OF 2 FREON LOOPS D/O PREP)

**LOSS OF 2 FREON LOOPS
ON-ORBIT
MS COMM PAGE**

A10-66

OV103,104

OPCL/ALL/GEN M

COMM POWERUP (If comm reqd prior to landing site coverage)

Pwr up audio sys:

C3 1. AUD CTR – 1
O5 √L AUD PWR – AUD
O9 √R AUD PWR – AUD

If UHF avail, config for UHF comm (voice only):

O6 2. UHF MODE sel – SPLX
√SPLX/EVA PWR AMPL – ON
3. After comm with MCC complete: Go to COMM
PWRDN, 10-65 >>

If UHF site unavail or if MCC requests data
(config for GSTDN(SGLS) S-BD):

C3 4. √S-BD PM CNTL – PNL
A1L ANT SW ELEC – 2
MODE sel – STDN LO(SGLS)
XPNDR – 2

5. NSP PWR – 2
DATA RATE XMIT – HI
RCV – HI
CODING XMIT – OFF
RCV – OFF
√UPLK DATA – S-BD

C3/F9 6. Sel best S-BD PM ANT

If MCC requests data:

O14:B : 7. cb MNA OI MDM OF 1/2 A,3/4 A (two) – cl
O17:D : 8. SIG CONDR OA 1/2/3 – ON
: 9. MDM OA 1/2/3 – ON
C3 : 10. OI PCMMU PWR – 1
O6 : 11. MDM PL2 – ON
: 12. GNC I/O RESET
: At end of data transmission:
O14:B : 13. cb MNA OI MDM OF 1/2 A,3/4 A (two) – op
O17:D : 14. SIG CONDR OA 1/2/3 – OFF
: 15. MDM OA 1/2/3 – OFF
: After comm/data complete:
L 16. Go to COMM PWRDN, 10-65

Cont next page

**LOSS OF 2 FREON LOOPS
ON-ORBIT
MS COMM PAGE**

A10-67

OV103,104

OPCL/ALL/GEN M

↑
If UHF site and GSTDN unavail and comm/data critical:
Config for TDRS S-BD:

CAUTION

This is a High Pwr Mode. On-time should be limited to 10 min max due to Pwr Amp Thermal constraints. A 3-min delay occurs after S-BD PM PNL/CMD before Pwr Amp is active. Uplink not affected. Proceed with selection of best antenna

- C3
A1L
17. √S-BD PM CNTL – PNL
18. √ANT SW ELEC – 2
√PRE AMP – 2
√PWR AMPL OPER – 2
MODE sel – TDRS DATA
√XPNDR – 2
19. √NSP PWR – 2
√DATA RATE XMIT – HI
RCV – HI
CODING XMIT – ON
RCV – ON
√UPLK DATA – S-BD
- C3/F9
20. Sel best S-BD PM ANT
If MCC requests data:
- O14:B : 21. cb MNA OI MDM OF 1/2 A,3/4 A (two) – cl
O17:D : 22. SIG CONDR OA 1/2/3 – ON
: 23. MDM OA 1/2/3 – ON
- C3 : 24. OI PCMMU PWR – 1
O6 : 25. MDM PL2 – ON
: 26. GNC I/O RESET
: At end of data transmission:
- O14:B : 27. cb MNA OI MDM OF 1/2 A,3/4 A (two) – op
O17:D : 28. SIG CONDR OA 1/2/3 – OFF
L 29. MDM OA 1/2/3 – OFF
- After comm/data complete:
30. Go to COMM PWRDN, 10-65

**LOSS OF 2 FREON LOOPS
ON-ORBIT
MS COMM PAGE**

A10-68

OV103,104

OPCL/ALL/GEN M

LOSS OF FES

- MS Perform MS PWRDN, 10-71, immed
- C3 1. \sqrt MSTR MADS PWR – OFF
2. Minimize Itg
3. Use one PGSC, and one IDP/CRT with two MDUs only as reqd
- If FLT CNTLR PWR not reqd:
- O14,O15,
O16:E 4. cb DDU L,R,AFT (six) – op
- O7 5. \sqrt TACAN MODE sel (three) – OFF
O8 6. \sqrt RDR ALTM (two) – OFF
7. \sqrt MLS (three) – OFF
8. Perform PL PWRDN, then:
- L1 9. CAB TEMP CNTLR – OFF
10. H2O LOOP 2 BYP MODE – MAN
MAN – DECR (hold 30 sec)
PUMP LOOP 1 (two) – OFF, B
11. \sqrt FLOW PROP VLV LOOP tb (two) – ICH
12. \sqrt TOP EVAP HTR NOZ L,R (two) – OFF
 \sqrt DUCT sel – OFF
13. \sqrt HI LOAD DUCT HTR sel – OFF
- L2 14. \sqrt NWS – OFF
15. \sqrt ANTISKID – OFF
- L4:L 16. cb CAB T CNTLR 1,2 (two) – op
R2 17. BLR CNTLR/HTR (three) – OFF
- MMU 2 deact:
18. SM 1 DPS UTILITY
 \sqrt MMU ASSIGN 1 SM – ITEM 3 EXEC
MMU 2 – OFF
- O15:F If IMU ALIGN not reqd, mnvr to tail Sun att:
19. GNC UNIV PTG
TGT ID – ITEM 8 +4 EXEC
BODY VECT – ITEM 14 +5 EXEC
P – ITEM 15 +1 8 4 EXEC
Y – ITEM 16 +0 EXEC
OM – ITEM 17 +9 0 EXEC ($\beta < 0$)
+2 7 0 EXEC ($\beta > 0$)
START TRK – ITEM 19 EXEC
20. Confirm MS pwrdn activities complete, then:
For deorbit prep:
21. Go to LOSS OF FES (CONT DEORB)

OV103,104

A10-69

OPCL/3,4/GEN M

This Page Intentionally Blank

OV103,104

A10-70

OPCL/ALL/GEN M

MS PULLOUT PAGE

MS2 Deploy rads, RAD DEPLOY (ORB OPS, ECLS)
MS1 Perform pwrn below

MS PWRDN

1. Minimize Itg
- O14, O15, O16:A 2. √BRAKES (three) – OFF
- O14, O15, O16:E 3. √cb ADTA (four) – op
- O14:B 4. MSN TIMER FWD – op
EVENT TIMER AFT – op
- O15:B 5. MSN TIMER AFT – op
EVENT TIMER FWD – op
- A1L 6. PL DATA INTLVR PWR – OFF
- A12 7. APU HTR LUBE OIL LN (three) – OFF
8. HYD HTR (eight) – OFF
- A14 9. RCS/OMS HTR FWD RCS – OFF
L,R POD (four) – OFF
OMS CRSFD LN (two) – OFF
- R14:D 10. cb TV (fifteen) – op
:E CAMR (six) – op
- A3 11. MON 1,2 PWR (two) – OFF
- ML31C 12. VAC VENT NOZ HTR – OFF
- If Manned Mnvr Unit is pwrn:
- ML86B:D 13. cb MNA,MNB STBD HTR A,B (two) – op
PORT HTR A,B (two) – op
- MD44F 14. Cab temp cntl act link – pin to FULL COOL

LOSS OF FES
ON-ORBIT
MS COMM PAGE

A10-71

OV103,104

OPCL/ALL/GEN M,3

This Page Intentionally Blank

**LOSS OF FES
ON-ORBIT
MS COMM PAGE**

A10-72

OV103,104

OPCL/ALL/GEN M

AV BAY FIRE

AV BAY 1

NOTE

While performing proc, note any cbs open.

Equipment still pwr'd in Av Bay following pwr'dn:

FPCA 1	MDM OF1
FLCA 1	DSC OF1
IMU FAN	ACCU

If docked with ISS, proc results in loss of Lo Z Translation.

If no active GNC GPC: Perform GNC RECOVERY VIA G2FD (DPS), 3-12, concurrent with remainder of this proc

- R1 1. cb AC CONTR AC1 (three) – cl
 2. INV/AC BUS 1 – OFF (tb-OFF)
 INV PWR 1 – OFF (tb-OFF)
 3. cb AC CONTR AC1 (three) – op
 4. Perform FC1 SHUTDN, except PWRDN (Cue Card),
 then:
- L1 5. √AV BAY 1 FAN A,B (two) – OFF
 6. FREON PUMP LOOP 2 – A
 7. AV BAY 3 FAN A – ON
 B – OFF
- C3 8. OI PCMMU FORMAT – FXD
 PWR – 2
- O6 9. BFC CRT DISP – ON
 10. √GPC PWR 5 – ON
 √OUTPUT 5 – NORM
 MODE 5 – STBY (tb-RUN), RUN
 11. 4 – STBY (tb-bp), HALT
 PWR 4 – OFF
- If GNC RECOVERY VIA G2FD (DPS), 3-12, performed:
 12. Go to step 15
- If Single G2 GPC OPS:
 13. Perform G2 SET EXPANSION, target Dual G2
 (ORB OPS, DPS), then:
- If/when in Multiple GPC OPS:
 14. Reassign strings to GPC 2 in MC 2
 GNC 0 GPC MEMORY

Cont next page

OV103,104

A10-73

OPCL/ALL/GEN M

CRT		CONFIG – ITEM 1 +2 EXEC Modify MC 2 per table --> DOWNLIST GPC – ITEM 44 +2 EXEC	CONFIG 2 GPC 02000
O6	15.	GNC, OPS 201 PRO GPC MODE 1(3) – STBY (tb-bp) – HALT PWR 1 – OFF	STR 1 2 2 2 3 2 4 2 PL 1/2 0 CRT 1 2 2 2 3 0 4 2
O7	17.	Perform PL PWRDN, then:	L 1 0
O8	18.	√TACAN 1 MODE sel – OFF	2 0
	19.	√RDR ALTM 1 – OFF	MM 1 2
	20.	√MLS 1 – OFF	2 2
	21.	<u>GNC 23 RCS</u>	
CRT		RCS FWD – ITEM 1 EXEC (*) MANF VLVS STAT OVRD – ITEM 41 EXEC – CL (MANF 2)	
O13:A	22.	cb ESS 1BC AC1 SNSR – op	
:E		3AB GPC STAT – op	
O14:A	23.	√BRAKES MNA – OFF	
:C	24.	cb MNA TACAN 1 – op	
:E	25.	RDR ALTM 1 – op MLS 1 – op √ADTA 1 – op √ACCEL 1 – op	
:F	26.	MMU 1 – OFF	
	27.	RJDF 1B F1 LOGIC – OFF DRIVER – OFF	
O15:F	28.	RJDF 1A F2 LOGIC – OFF DRIVER – OFF	
	29.	√ACCEL 4 – OFF	
O16:A	30.	√BRAKES MNC – OFF	
:E	31.	√cb MNC ADTA 3 – op	
A1R	32.	PL DATA INTLVR PWR – OFF	
	33.	S-BD PL CNTL – PNL,CMD	
MA73C:A	34.	MCA LOGIC MNA FWD 1 – OFF	
AW18H	35.	√PWR/BATT CHGR EMU 1,2 BUS SEL (two) – OFF	
A12	36.	HYD CIRC PUMP PWR 1 – MNB 2 – MNC 3 – MNA	

Cont next page

OV103,104

A10-74

OPCL/3,4/GEN M,10

- L4:G 37. cb AC2 Φ A, Φ B, Φ C AV BAY 1 FAN B (three) – op
 38. Perform MAL, EPS SSR-110, BUS LOSS: AC1,
 except:
 L1 \surd AV BAY 1 FAN A,B (two) – OFF, then:
 39. Reassign SM into GPC 3, per MAL, DPS SSR-4,
 SM REASSIGNMENT
 40. Perform LOAD PCMMU FORMAT, using TFL
 161/103 (ORB OPS FS, COMM/INST), then:
 C3 41. BFC CRT DISP – OFF
 SEL – 3+1
 Check all IDPs deassigned from BFS
 O6 GPC MODE 5 – STBY,HALT (tb-bp)
 \surd OUTPUT 5 – NORM
 For deorb prep:
 If orbit 3 deorbit:
 42. Go to LAUNCH DAY DEORBIT PREP
 (ORBIT 3) (CONT DEORB) >>
 43. Perform MAL, ECLS SSR-12, AV BAY FIRE
 RECOVERY/RECONFIG, Checkout and Recovery,
 then:
 For deorb prep:
 If orbit 7 deorbit:
 44. Perform P&I nominal POST INSERTION,
 DEORB PREP (POST INSERT, ORBIT 7
 D/O), then:
 45. Go to AV BAY FIRE (DEORB PREP,
 CONTINGENCY DELTAS)

OV103,104

A10-75

OPCL/3,4/GEN M,10

This Page Intentionally Blank

OV103,104

A10-76

OPCL/ALL/GEN M

AV BAY 2

NOTE

While performing proc, note any cbs open.

Equipment still pwr'd in Av Bay following pwr'dn:

FPCA 2 MDM OF2
FLCA 2 DSC OF2
BFC 3A (When GPC 3 is powered).

If docked with ISS, proc will require ISS to control mated attitude or result in loss of mated attitude control. Proc also results in loss of Lo Z Translation

- | | | |
|-----|-----|---|
| R1 | 1. | cb AC CONTR AC2 (three) – cl |
| | 2. | INV/AC BUS 2 – OFF (tb-OFF)
INV PWR 2 – OFF (tb-OFF) |
| | 3. | cb AC CONTR AC2 (three) – op |
| | 4. | Perform <u>FC2 SHUTDN</u> , except PWRDN (Cue Card),
then: |
| L1 | 5. | IMU FAN A(C) – ON
B – OFF |
| | 6. | AV BAY 1 FAN A – ON
B – OFF |
| | 7. | FREON PUMP LOOP 1 – A |
| | 8. | √CAB FAN A – ON
√B – OFF |
| | 9. | √AV BAY 2 FAN A,B (two) – OFF |
| C3 | 10. | √OI PCMMU PWR – 1 |
| A1L | 11. | √S-BD PM MODE sel – TDRS DATA
√NSP DATA RATE XMIT – HI
√RCV – HI
√CODING XMIT – ON
√RCV – ON
√PWR – 1
√UPLK DATA – S-BD |
| C3 | 12. | S-BD PM CNTL – PNL,CMD |

Cont next page

A10-77

OV103,104

OPCL/ALL/GEN M

REASSIGN STRINGS TO GPC 1 IN MC 2

CRT O6 O7 O8 O13:C O15:A :C :E :E :F O14,O15, O16:F O16:A :E :F A1L	13. GNC 0 GPC MEMORY CONFIG – ITEM 1 +2 EXEC Modify MC 2 per table -- → 14. GNC, OPS 201 PRO 15. GPC MODE 2 – STBY(tb-bp) – HALT PWR 2 – OFF √MODE 5 – HALT √OUTPUT 5 – NORM √PWR 5 – OFF 16. MDM FF2,FF4 (two) – OFF PL2 – OFF 17. Perform PL PWRDN, then: 18. √TACAN 2 MODE sel – OFF 19. √RDR ALTM 2 – OFF 20. √MLS 2,3 (two) – OFF 21. cb ESS 2CA AC2 SNSR – op 22. √BRAKES MNB – OFF If OV103: 23. cb MNB TACAN 2 – op 24. cb MNB RDR ALTM 2 – op MLS 2 – op √ADTA 2 – op √ACCEL 2 – op If OV104: 25. cb MNB TACAN 2 – op 26. MMU 2 – OFF 27. √RJDA LOGIC,DRIVER (eight) – ON 28. GNC 20 DAP CONFIG – sel tail only P,Y OPTION – ITEM 15,16 EXEC (TAIL) – ITEM 35,36 EXEC (TAIL) 29. DAP: PRI 30. √BRAKES MNC – OFF 31. cb MNC MLS 3 – op √ADTA 4 – op 32. RJDF 2A F3 LOGIC – OFF DRIVER – OFF 2B F4/F5 LOGIC – OFF F4 DRIVER – OFF 33. √ACCEL 3 – OFF 34. RJD MANF L5/F5/R5 DRIVER – OFF 35. S-BD PL PWR SYS – OFF CNTL – PNL,CMD	<table border="1" style="border-collapse: collapse; text-align: center;"> <thead> <tr> <th style="padding: 5px;">CONFIG</th> <th style="padding: 5px;">2</th> </tr> </thead> <tbody> <tr> <td style="padding: 5px;">GPC</td> <td style="padding: 5px;">10000</td> </tr> <tr> <td style="padding: 5px;">STR 1</td> <td style="padding: 5px;">1</td> </tr> <tr> <td style="padding: 5px;">2</td> <td style="padding: 5px;">1</td> </tr> <tr> <td style="padding: 5px;">3</td> <td style="padding: 5px;">1</td> </tr> <tr> <td style="padding: 5px;">4</td> <td style="padding: 5px;">1</td> </tr> <tr> <td style="padding: 5px;">PL 1/2</td> <td style="padding: 5px;">0</td> </tr> <tr> <td style="padding: 5px;">CRT 1</td> <td style="padding: 5px;">1</td> </tr> <tr> <td style="padding: 5px;">2</td> <td style="padding: 5px;">1</td> </tr> <tr> <td style="padding: 5px;">3</td> <td style="padding: 5px;">0</td> </tr> <tr> <td style="padding: 5px;">4</td> <td style="padding: 5px;">1</td> </tr> <tr> <td style="padding: 5px;">L 1</td> <td style="padding: 5px;">0</td> </tr> <tr> <td style="padding: 5px;">2</td> <td style="padding: 5px;">0</td> </tr> <tr> <td style="padding: 5px;">MM 1</td> <td style="padding: 5px;">1</td> </tr> <tr> <td style="padding: 5px;">2</td> <td style="padding: 5px;">1</td> </tr> </tbody> </table>	CONFIG	2	GPC	10000	STR 1	1	2	1	3	1	4	1	PL 1/2	0	CRT 1	1	2	1	3	0	4	1	L 1	0	2	0	MM 1	1	2	1
CONFIG	2																															
GPC	10000																															
STR 1	1																															
2	1																															
3	1																															
4	1																															
PL 1/2	0																															
CRT 1	1																															
2	1																															
3	0																															
4	1																															
L 1	0																															
2	0																															
MM 1	1																															
2	1																															

- A12
- MA73C:A
L4:H
36. √HYD CIRC PUMP PWR 1 – MNA
2 – MNB
3 – MNC
 37. MCA LOGIC MNB FWD 2 – OFF
 38. cb AC3 AV BAY 2 FAN B (three) – op
 39. Perform MAL, EPS SSR-120, BUS LOSS: AC2, except:
L1 √AV BAY 2 FAN A,B (two) – OFF, then:
 40. Reassign BFS into GPC 3, per MAL, DPS SSR-7, GPC IPL MENU OPTION (PASS/BFS)
- For deorb prep:
If orbit 3 deorbit:
41. Go to LAUNCH DAY DEORBIT PREP (ORBIT 3) (CONT DEORB) >>
 42. Perform MAL, ECLS SSR-12, AV BAY FIRE RECOVERY/RECONFIG, Checkout and Recovery, then:
- For deorb prep:
If orbit 7 deorbit:
43. Perform Deltas to nominal POST INSERTION, DEORB PREP (POST INSERT, ORBIT 7 D/O), then:
 44. Go to AV BAY FIRE (DEORB PREP, CONTINGENCY DELTAS)

OV103,104

A10-79

OPCL/3,4/GEN M,10

This Page Intentionally Blank

OV103,104

A10-80

OPCL/ALL/GEN M

AV BAY 3A

NOTE

While performing proc, note any cbs open.

Equipment still pwr'd in Av Bay following pwr'dn:

FPCA 3 MDM OF3 GCIL

FLCA 3 DSC OF3

Active comm sys equipment

S-BD PWR-AMP stby (alt sys)

- R1 1. cb AC CONTR AC3 (three) – cl
- 2. INV/AC BUS 3 – OFF (tb-OFF)
- INV PWR 3 – OFF (tb-OFF)
- 3. cb AC CONTR AC3 (three) – op
- 4. Perform FC3 SHUTDN, except PWRDN (Cue Card), then:
- L1 5. AV BAY 3 FAN A,B (two) – OFF
- 6. CAB FAN B – ON
- A – OFF
- L4:F 7. cb AC1 H2O LOOP PUMP 1A/2 (three) – cl
- L1 H2O PUMP LOOP 1 – ON
- 2 – GPC

If Triple G2:

- CRT 8. CONFIG – ITEM 1 +2 EXEC
 Modify MC 2 per table -- -->
- 9. GNC, OPS 201 PRO
- O6 10. √GPC MODE 3 – HALT
- √OUTPUT 3 – NORM
- √PWR 3 – OFF
- 11. MDM FF3 – OFF
- 12. Perform PL PWRDN, then:
- O7 13. √TACAN 3 MODE sel – OFF
- O13:A 14. cb ESS 1BC C/W A – op
- 2CA C/W B – op
- (all SM tones and C/W lights and tones lost; CRT FAULT SUMM and SM ALERT light remains)
- O13:E 15. cb ESS 3AB AC3 SNSR – op
- 16. Perform LOSS OF VERNIERS (ORB OPS, RCS) while continuing with pwr'dn, then:

CONFIG	2
GPC	12000
STR	1
2	2
3	1
4	2
PL	1/2
0	0
CRT	1
1	1
2	2
3	0
4	1
L	1
0	0
2	0
MM	1
1	1
2	2

Cont next page

OV103,104

A10-81

OPCL/3,4/GEN M,10

- If comm not working:
- A1L 17. √S-BD PM MODE sel – TDRS DATA
 √NSP DATA RATE XMIT – HI
 √RCV – HI
 √CODING XMIT – ON
 √RCV – ON
 √PWR – 1
 √UPLK DATA – S-BD
- C3 18. S-BD PM CNTL – PNL,CMD
- If comm still not working:
19. S-BD PL CNTL – PNL
 PWR SYS – OFF
- A1L 20. PL DATA INTLVR PWR – OFF
- C3 21. S-BD PM CNTL – PNL
 ANT SW ELEC – OFF
 PRE AMP – OFF
 PWR AMPL STBY – OFF
 OPER – OFF
- A1L 22. NSP PWR – OFF
 ENCRYPTION PWR – OFF
- MA73C:A 23. MCA LOGIC MNC FWD 3 – OFF

NOTE

If comm presently working, performing a PNL,CMD may result in loss of comm (if fire has aff alt comm sys)

- L4:H 24. cb AC1 AV BAY 3 FAN B (three) – op
- O16:C 25. MNC TACAN 3 – op
26. Perform MAL, EPS SSR-130, BUS LOSS: AC3, except:
 L1 √AV BAY 3 FAN A,B (two) – OFF, then:
- For deorb prep:
 If orbit 3 deorbit:
 27. Go to LAUNCH DAY DEORBIT PREP (ORBIT 3) (CONT DEORB, LAUNCH DAY ORBIT 3) >>
28. Perform MAL, ECLS SSR-12, AV BAY FIRE RECOVERY/RECONFIG, Checkout and Recovery, then:
- For deorb prep:
 If orbit 7 deorbit:
 29. Perform Deltas to nominal POST INSERTION, DEORB PREP (POST INSERT, ORBIT 7 D/O), then:
30. Go to AV BAY FIRE (DEORB PREP, CONTINGENCY DELTAS)

OV103,104

PWRDN

LOSS OF 2 CAB FANS	10-2
2 H2O LOOPS	10-7
CAB PRESS.....	10-27
HI LOAD EVAP	10-33
1 FREON LOOP	10-35
1 FC.....	10-39
2nd FC ON-ORBIT (TIG < 4 hr)	10-41
(TIG > 4 hr)	10-45
2 FREON LOOPS	10-49
FES	10-69
AV BAY FIRE.....	10-73
1	10-73
2	10-77
3A.....	10-81

PWRDN

OV105

B10-1

OPCL/ALL/GEN M

LOSS OF 2 CAB FANS

MS1,2 1. Perform MS PWRDN, 10-5, ASAP

NOTE

Normal CO2 removal and humidity control lost.
Wipe off any visible moisture with towel.

Cab press increase due to air heating may
cause CAB PRESS RELIEF vlv cycling

PWRDN

C3 2. MSTR MADS PWR – OFF
3. Minimize Itg

FWD 4. All MDU PWR (nine) – OFF
C2 All IDP/CRTs (three) – OFF
F6/F8 √FLT CNTLR PWR (two) – OFF

O14,O15, If FLT CNTLR PWR not reqd:
O16:E 5. cb DDU L,R,AFT (six) – op

L1 6. CAB FAN A,B (two) – OFF
TEMP CNTLR – OFF

7. HUM SEP A,B (two) – OFF

8. Use one PGSC

W1-10 9. Install Window Shades or mnvr to tail Sun att

GNC 201 UNIV PTG

TGT ID – ITEM 8 +4 EXEC

BODY VECT – ITEM 14 +5 EXEC

P – ITEM 15 +1 8 4 EXEC

Y – ITEM 16 +0 EXEC

OM – blank (MCC-provided if reqd)

C3 DAP: A/AUTO/VERN

CRT START TRK – ITEM 19 EXEC (*)

10. Cycle MDUs. If ON at loss of cooling, turn OFF within
30 min. Allow 3 min OFF prior to each 1 min ON (30
min max ON time). Save two MDUs that interface with
a single IDP for entry

Cont next page

B10-2

OV105

OPCL/ALL/GEN M

NOTE

Don QDM for temp > 90 degF and discomfort.
If cab temp > 95 degF and no evaporative
cooling is sensed, don LES, check tabs, close
visor, LES O2 – ON.

Inflate anti-g suit as needed for on-orbit
circulatory support.

Begin drinking H2O (one 8-oz container every
15 min with a salt tablet in every other
container) and continue through entry

11. Go to LOSS OF 2 CAB FANS (DEORB PREP,
CONTINGENCY DELTAS) and perform at next PLS
opportunity. Expedite NOMINAL DEORBIT PREP proc
if time-to-TIG < 3.5 hr

OV105

B10-3

OPCL/ALL/GEN M

This Page Intentionally Blank

B10-4

OV105

OPCL/ALL/GEN M

MS PULLOUT PAGE

MS1 Perform PLB EQUIP PWRDN, 10-6
MS2 Perform MS PWRDN ASAP

MS PWRDN

O14:B 1. Minimize Itg
:C 2. cb MNA EVENT TIMER AFT – op
SMOKE DETN L/R FLT DK – op
O15:B 3. MNB OI H2O BYP LOOP 2 SNSR – op
MSN TIMER AFT – op
O16:C 4. MNC SMOKE DETN CAB – op
L4:J 5. AC3 Φ A SIG CONDR HUM SEP – op
A6U 6. ANNUN BUS SEL – OFF
A13 7. OS AUD SPKR PWR – OFF

NOTE

Galley OVEN/RHS sw should be
OFF unless dispensing H2O

GALLEY 8. OVEN/RHS – ON, as reqd
H2O HTRS (two) – OFF
MA73C:G 9. cb AC3 GALLEY FAN (three) – op
ML86B:B 10. MNB GALLEY H2O HTR – op
If RMS pwr dn:
A3 11. MON 1,2 PWR (two) – OFF
A7U 12. TV PWR CNTL – PNL
CONTR UNIT – OFF
13. VID OUT MON1,MON2 pb (two) – push
(MON1,MON2 It on)
O19 14. TV PWR – OFF
R12L 15. VTR PWR – OFF
MO58F 16. TV PWR – OFF
If not reqd:
R11L 17. IDP/CRT4 PWR – OFF
CRT4,AFD1 MDU PWR – OFF
A6U 18. FLT CNTLR PWR – OFF

**LOSS OF 2 CAB FANS
ON-ORBIT
MS PAGE**

B10-5

OV105

OPCL/ALL/GEN M,6

PLB EQUIP PWRDN

1. Perform PL SAFING, then:

<p style="text-align: center;">CAUTION</p> <p>If stow prob occurs with either RMS and/or KU-BD ANT, perform aff sys <u>QUICK RESPONSE JETTISON</u> (CONT DEORB)</p>
--

If RMS grappled to OBSS:

2. Perform OBSS JETTISON (PDRS OPS FS, OBSS CONTINGENCY), then:

If RMS-only:

3. Perform RMS PWRDN (PDRS OPS), then:

If KU-BD ANT deployed:

4. Perform KU-BD ANT STOW (ORB OPS, COMM/INST), then:

If radiators deployed:

5. Go to RAD STOW (ORB OPS, ECLS)

LOSS OF 2 H2O LOOPS

NOTES

- THIS PROCEDURE IS TIME CRITICAL
 - Proc requires > 45 min, but time critical steps should be done ASAP
 - Loss of H2O cooling aff both water and air cooled equipment
 - Proc pwrns dn all comm. If comm reqd, preferred comm config in order of heat production:
 1. UHF only
 2. SGLS/STDN LO PWR if reqd
 3. TDRS only if mandatory (10 min max)
 - Call ground at every avail UHF site
 - Tear out COMM pages from proc and use until touchdown
 - Cab depress/repress cycles to 10.2 psia are used for cab temp and humidity control
 - If docked to ISS, proc is to be worked simo with JOINT EXPEDITED UNDOCKING AND SEPARATION (SODF: JOINT OPS)
 - When pwrdns complete, perform actions on 10-19 and 10-20 as time permits at crew discretion
1. Perform PART 1 of this pwrdn and, based on TIG, complete PART 2 or PART 3

Cont next page

B10-7

OV105

OPCL/ALL/GEN M

LOSS OF 2 H2O LOOPS, PART 1 – INITIAL PWRDN

TIME CRITICAL PROCEDURES (execute simo)

1. Record MET of 2nd H2O Loop Fail
2. / : :
Establish comm plan with MCC, determine best TIG opportunities, then have MS3 perform COMM PWRDN, 10-23, ASAP (S-Bd Pwr Amp may fail in 10 min with no cooling)
3. Have MS perform MS OVHD PNL PWRDN, 10-19, ASAP
4. Have second MS perform MCA CONFIG, 10-17, and PLB EQUIP PWRDN, 10-17, ASAP
5. If docked to ISS, have CDR perform JOINT EXPEDITED UNDOCKING AND SEPARATION (SODF: JOINT OPS)
6. Have PLT proceed with CDR AND PLT PWRDN, ASAP

DETERMINE MAXIMUM TIME TO TIG, NUMBER OF DEP/REP, FROM N2 QTY FROM SPEC 66. Sel best landing site and deorbit TIG from PGSC. Set Wristwatch Timer (A17) counting down to TIG.

TIG:	_____
TGTS:	_____
C1	_____
C2	_____
HT	_____
ΘT	_____

Enter TARGETS in LOSS OF 2 H2O LOOPS DEORBIT PREP/ENTRY (CONT DEORB, LOSS OF 2 H2O LOOPS D/O PREP)

<u>IF TOTAL N2</u>	<u>NUMBER OF DEP/REP</u>	<u>SEL BEST TIG WITHIN</u>
>160 LB	3	45M - 4H:00M
>120 LB	2	45M - 2H:50M

CDR AND PLT PWRDN

- O14,O15, 7. √Pri RJD LOGIC,DRIVER (sixteen) – ON
O16:F
- O16:F
C3 8. DAP: ALT (proc results in loss of VERNs)
RJD MANF L5/F5/R5 DRIVER – OFF
9. √MSTR MADS PWR – OFF
10. Minimize Itg
Use only one IDP with two MDUs, one PGSC

NOTE

Cycle MDUs. If ON at loss of cooling, turn OFF within 30 min. Allow 2 min OFF prior to each 1 min ON (30 min max ON time). Save two MDUs that interface with a single IDP for entry. IDPs do not require cycling

Cont next page

B10-8

OV105

OPCL/ALL/GEN M

- F6,F8,A6 11. FLT CNTLR PWR (three) – OFF, use one as reqd
- O7 12. GPS PWR (three) – OFF
- O8 13. √RDR ALTM (two) – OFF
- 14. √MLS (three) – OFF
- L1 15. √H2O PUMP LOOP 1,2 (two) – OFF
(leave ON if any loop running)
HUM SEP (two) – OFF
(leave HUM SEP A ON if any loop running)

If any loop running, minimize bypass:

- 16. H2O LOOP 1(2) BYP MODE – MAN
MAN – DECR (30 sec)

If H2O PUMP LOOP 1 A(B) ON, inform MS:

- MA73C:A 17. √MCA LOGIC MNA FWD 1 – ON
(MNB FWD 2 – ON)

- L1 18. CAB FAN (two) – OFF
TEMP CNTLR – OFF
- 19. √FLOW PROP VLV LOOP tb (two) – ICH
- 20. FREON PUMP LOOP 1 – OFF
√2 – B
- 21. HI LOAD DUCT HTR sel – A/B
√TOP EVAP HTR NOZ L,R (two) – B AUTO(A AUTO)
√DUCT sel – B(A)

- L2 22. O2 SYS 1 SPLY – CL (tb-CL)
- L4:J 23. cb AC3 φA SIG CONDR HUM SEP – op

If not currently single G2, reassign strings to GPC 1 in MC 2:

- 24. GNC 0 GPC MEMORY
CONFIG – ITEM 1 +2 EXEC
Modify MC 2 per table ----->
- CRT 25. GNC, OPS 201 PRO
- O6 26. GPC MODE 2 – STBY
(tb-bp)
– HALT
– STBY
(tb-RUN)
– HALT
(tb-bp)
- 27. √GPC MODE 3,5 (two) – HALT
√OUTPUT 5 – NORM
- L1 28. AV BAY 1 FAN A – ON
B – OFF
2,3 FAN A,B (four) – OFF
- 29. IMU FAN A – ON
B – OFF
√C – OFF

	CONFIG	2
	GPC	10000
STR	1	1
	2	1
	3	1
	4	1
PL	1/2	0
CRT	1	1
	2	1
	3	0
	4	1
L	1	0
	2	0
MM	1	1
	2	1

For any fwd IDP/CRT that is OFF:

- 30. GPC/CRT1/X EXEC
- R2 31. HYD CIRC PUMP (three) – ON

Cont next page

B10-9

OV105

OPCL/5/GEN M

C3 32. C/W MODE – ACK

NOTE

For F7 lights, hold in F2 or F4 MA

If current time to TIG < 50 min:

33. Go to LOSS OF 2 H2O LOOPS, PART 2 – SHORT ON-ORBIT WAIT, next page >>

L1 34. Cycle CAB FAN A(B) – ON (7 min)/OFF (1 hr)
(to control PPCO2)

L4:P 35. cb AC2,3 Φ A LG SNSR (two) – op

WARNING

Do not unpwr all IMU/FF MDM's pairs

If IMU 2 in OPER:

O14,O16:A 36. GNC 21 IMU ALIGN
IMU 1,3 (two) – desel
37. IMU 1,3 (two) – OFF

If IMU 2 in STBY:

O15,O16:A 38. GNC 21 IMU ALIGN
IMU 2,3 (two) – desel
O6 39. IMU 2,3 (two) – OFF
40. MDM FF3,FF4 (two) – OFF
41. Verify MS OVHD PWRDN complete

NOTE

Both MMUs are OFF. If a ROLL-IN DISPLAY is reqd: turn MMU 1 ON, try transaction, turn MMU 1 OFF again

If time from failure to TIG < 2 hr 30 min:

42. Go to LOSS OF 2 H2O LOOPS, PART 2 – SHORT ON-ORBIT WAIT, next page >>

If time from failure to TIG > 2 hr 30 min:

43. Go to LOSS OF 2 H2O LOOPS, PART 3 – EXTENDED ON-ORBIT WAIT, 10-13

OV105

B10-10

OPCL/ALL/GEN M

LOSS OF 2 H2O LOOPS, PART 2 – SHORT ON-ORBIT WAIT

If Undocking from ISS, delay step 1 until after Undocking and Post Final Sep, but continue with steps 2 through 19 of PART 2 – SHORT ON-ORBIT WAIT:

1. Perform POST UNDOCKING AND FINAL SEP RECONFIG, 10-15

BYPASS RADS/FES ACT

- | | | |
|---------|----|---|
| ML86B:A | 2. | cb MNC SPLY H2O XOVR VLV – cl |
| R11L | 3. | SPLY H2O XOVR VLV – OP (tb-OP)
√TKA OUTLET – CL (tb-CL) |
| L1 | 4. | FLASH EVAP CNTLR (three) – OFF |
| | 5. | HI LOAD EVAP – ENA
RAD BYP VLV MODE 1,2 (two) – MAN
MAN SEL 1,2 (two) – BYP,
wait 3 sec (tb-BYP)
CNTLR LOOP 1,2 (two) – OFF |
- When EVAP OUT T > 65:
6. FLASH EVAP CNTLR PRI A(B) – ON
 7. Wait 1 min, verify EVAP OUT T = 39 degF
 8. Give MS GO to perform PLBD CLOSURE, 10-18
- If current time to TIG < 50 min, at TIG-30 min:
9. Go to LOSS OF 2 H2O LOOPS DEORBIT PREP/ENTRY (CONT DEORB, LOSS OF 2 H2O LOOPS D/O PREP) >>

NOTE

Limit operation of each GPC (1 hr max ON time from second H2O Loop failure)

If reqd, perform steps 10 thru 13:

- | | | |
|------|-----|--|
| O6 | 10. | GPC MODE 2 – STBY (tb-RUN), hands off 10 sec
– RUN (OUTPUT tb-gray), hands off
10 sec |
| IDPX | 11. | In MCX add GPC 2 to tgt set (leave GPC 1 in tgt set)
Assign all strings to GPC2
(if SM GPC active, √PL 1/2 not assigned)
GNC, OPS X01 PRO
√All IDPs deassigned from GPC1 |
| O6 | 12. | GPC MODE 1 – STBY (tb-bp)
– HALT
– STBY (tb-RUN)
– HALT (tb-bp) |
| L1 | 13. | AV BAY 1 FAN A(B) – OFF
2 FAN A(B) – ON |

Wherever GPC 1 is referenced, replace with GPC 2 in the LOSS OF 2 H2O LOOPS DEORBIT PREP/ENTRY (CONT DEORB, LOSS OF 2 H2O LOOPS D/O PREP)

Cont next page

OV105

SM GPC/PL MDM Deact – Delay SM GPC/PL MDM Deact (steps 14-21) until PLBD are closed. Then perform ASAP:

- 14. SM 1 DPS UTILITY
UL CNTL ENA – ITEM 36 EXEC
- C3 15. UPLK – GPC BLK
- C2 16. IDP/CRT1,2,3 MAJ FUNC (three) – GNC
- O6 17. GPC MODE 4 – STBY (tb-bp)
– HALT
PWR 4 – OFF
- 18. GNC 0 GPC MEMORY
CONFIG – ITEM 1 +2 EXEC
- CRT 19. Assign PL1/2 to GPC 1 in MC2
- O6 20. GNC, OPS 201 PRO
- 21. MDM PL1,PL2 (two) – OFF
- 22. Perform first cab depress/repress cycle starting at approx 1 hr 15 min after the failure, the final cycle at TIG-20 min. Procs in the 20 MINUTE DE/REPRESS MS PULLOUT PAGE (CONT DEORB, LOSS OF 2 H2O LOOPS); use until last depress/repress is complete

NOTE

Possible cab air OVBD RLF due to loss of cab cooling.

Use Quick Don mask as needed to provide additional respirator cooling during periods of high cab temp and humidity. To determine health of crewmember, place temp strip (MED Kit) on forehead. If any crewmember temp greater than 99 degF and crew feels ill, begin cab depress/repress cycle ASAP

At TIG-30 min:

- 23. Go to LOSS OF 2 H2O LOOPS DEORBIT PREP/ENTRY (CONT DEORB, LOSS OF 2 H2O LOOPS D/O PREP) >>

OV105

B10-12

OPCL/ALL/GEN M

LOSS OF 2 H2O LOOPS, PART 3 – EXTENDED ON-ORBIT WAIT

If Undocking from ISS, delay step 1 until after undocking and Post Final Sep, but continue with steps 2 thru 6:

1. Perform POST UNDOCKING AND FINAL SEP RECONFIG, 10-15
- O6 2. \sqrt GPC MODE 2,3,5 (three) – HALT
3. PWR 2,3,5 (three) – OFF

When RMS PWRDN (PDRS OPS) complete, perform steps 4 thru 6 ASAP:

4. GPC MODE 4 – STBY (tb-bp), hands off 10 sec
– RUN (tb-RUN), hands off 10 sec
OUTPUT 4 – NORM (tb-gray)
5. GNC 0 GPC MEMORY
CONFIG – ITEM 1 +2 EXEC

Modify MC 2 per table ---->
GNC, OPS 201 PRO

CONFIG	2
GPC	10040
STR 1	1
2	1
3	1
4	1
PL 1/2	1
CRT 1	1
2	1
3	1
4	0
L 1	0
2	0
MM 1	1
2	1

- O6 6. GPC MODE 4 – STBY (tb-bp)
– HALT
– STBY (tb-RUN)
– HALT (tb-bp)
PWR 4 – OFF

Delay steps 7 thru 20 of PART 3 – EXTENDED ON-ORBIT WAIT, 10-14, until POST UNDOCKING AND FINAL SEP RECONFIG is complete (perform step 19 as reqd):

Cont next page

B10-13

OV105

OPCL/ALL/GEN M

- Establish free drift:
- F8 7. Verify att mnvr complete
ADI ATT – INRTL
 - C3 DAP: B/AUTO/PRI (wait 30 sec)
FREE
 - O6 8. MDM PL1,PL2 (two) – OFF
 - 9. √Wrist watch set to MET
- Pwr dn remaining GPC:
- 10. GNC, OPS 000 PRO
 - 11. GPC MODE 1 – STBY (tb-bp)
– HALT
– STBY (tb-RUN)
– HALT (tb-bp)
 - 12. GPC PWR 1 – OFF
- FWD,AFT 13. All MDU PWR (eleven) – OFF
 - C2,R11L IDP/CRT PWR (four) – OFF
 - L1 14. AV BAY FAN (six) – OFF
 - O13:C 15. cb ESS 2CA MTU B – op
:E 3AB GPC STAT – op
 - O14:B 16. MNA MSN TIMER FWD – op
:C SMOKE DETN L/R FLT DK – op
 - W1-10 17. Install Window Shades
 - 18. Check all pwrdns complete
 - 19. Perform first cab depress/repress cycle starting at approx 1 hr 15 min after the failure, the second at TIG-1:15 and the final cycle at TIG-20 min. Procs in the 20 MINUTE DE/REPRESS MS PULLOUT PAGE (CONT DEORB, LOSS OF 2 H2O LOOPS); use until last depress/repress is complete

NOTE

Possible cab air OVBD RLF due to loss of cab cooling.

Use QDM as needed to provide additional respirator cooling during periods of high cab temp and humidity. To determine health of crewmember, place temp strip (MED Kit) on forehead of CDR and PLT

- 20. Go to LOSS OF 2 H2O LOOPS, ON-ORBIT WAIT (CONT DEORB, LOSS OF 2 H2O LOOPS)

OV105

POST UNDOCKING AND FINAL SEP RECONFIG

If Undocking with ISS and Final Sep complete or if not docked with ISS:

1. **GNC 20 DAP CONFIG**
DAP A,B set to A1,B1 except:
(A) ITEM 10 +1.0 0 EXEC
ITEM 11 +3.0 0 EXEC
ITEM 15 EXEC (TAIL)
ITEM 16 EXEC (TAIL)
(B) ITEM 30 +0.2 0 EXEC
ITEM 31 +1.0 0 EXEC
ITEM 35 EXEC (TAIL)
ITEM 36 EXEC (TAIL)

CAUTION
DO NOT mnvr on PRCS until MS has completed RMS JETT or STOW

2. Mnvr to tail Sun att:
GNC 201 UNIV PTG
TGT ID – ITEM 8 +4 EXEC
BODY VECT – ITEM 14 +5 EXEC
P – ITEM 15 +2 2 5 EXEC
Y – ITEM 16 +0 EXEC
OM – blank (MCC-provided as reqd)
DAP: A/AUTO/PRI
START TRK – ITEM 19 EXEC (CUR-*)

- O6
O6
O14,O15,
O16:F
- If IMU 2 in OPER:
3. MDM FF1 – OFF
 - If IMU 2 in STBY:
4. MDM FF2 – OFF
 5. RJDF LOGIC,DRIVER (eight) – OFF

NOTE
Expect FRCS jet(s) to false fail leak when OF DSC cbs are opened

- O14:B
O15:B
O16:B
O16:E
6. cb MNA OI SIG CONDR OF 1/4 A – op
 7. cb MNB OI SIG CONDR OF 1/4 B – op
2/3 A – op
 8. cb MNC OI SIG CONDR OF 2/3 B – op
 9. DDU AFT – op

OV105

B10-15

OPCL/ALL/GEN M

This Page Intentionally Blank

B10-16

OV105

OPCL/ALL/GEN M

MCA CONFIG (Execute ASAP)

- L1 If either H2O PUMP LOOP 1 A(B) – ON:
MA73C:A 1. Leave MCA LOGIC MNA FWD 1(MNB FWD 2) ON
B in next step

CAUTION
Coordinate steps 2 and 3 with CDR. FRCS
is lost with step 2 and recovered with step 3

- MA73C:A, 2. MCA LOGIC MNA,B,C (fourteen) – OFF
B
3. **GNC 23 RCS**
ITEM 1 EXEC (FRCS page)
OVRD FRCS MANF(s) – OP
4. For PLB EQUIP PWRDN, use following MCA config:
MCA LOGIC MNA MID 1,3 (two) – ON
MNB MID 2,3,4 (three) – ON
MNC MID 2,4 (two) – ON

CAUTION
Retain this MCA sw config until step 8 of the PLB
EQUIP PWRDN. Disregard MCA sw throws in the
PL SAFING, RAD STOW, KU-BD ANT STOW,
and RMS PWRDN procs

- MO13Q 5. \sqrt AIRLK FAN A,B (two) – OFF

PLB EQUIP PWRDN (Execute ASAP)

1. Perform PL SAFING, then:

CAUTION
If stow prob occurs with either RMS and/or
KU-BD ANT, perform aff sys QUICK
RESPONSE JETTISON (CONT DEORB)

2. If TV reqd for OBSS jettison or RMS/Ku stow, perform
ACTIVATION and OPERATION (Auto Ops only) (Cue
Card, TV)

If RMS grappled to OBSS:

3. Perform OBSS JETTISON (PDRS OPS FS,
OBSS CONTINGENCY), then:

If RMS-only:

4. Perform RMS PWRDN (PDRS OPS), then:

Cont next page

LOSS OF 2 H2O LOOPS
ON-ORBIT
MS PAGE

B10-17

OV105

OPCL/ALL/GEN M

If KU-BD ANT deployed:

5. Perform KU-BD ANT STOW (ORB OPS, COMM/INST), then:

If radiators deployed:

6. Perform RAD STOW (ORB OPS, ECLS), then:

7. Notify CDR: RMS stowed(jettisoned)

If performing PART 2 – SHORT ON-ORBIT WAIT:

8. Perform PLBD CLOSURE, below, on GO from CDR, then:

- MA73C:A, 9. MCA LOGIC MNA MID 1,3 (two) – OFF
B MNB MID 2,3,4 (three) – OFF
MNC MID 2,4 (two) – OFF

PLBD CLOSURE (Short On-Orbit Wait only)

WARNING

Verify no obstructions before closing and latching PLBD (Ku ANT, RAD, RMS, etc)

1. Notify CDR: Beginning PLBD CLOSURE
- O6 2. \sqrt MDM PL1, PL2 (two) – ON
3. SM I/O RESET
- CRT4 4. SM, OPS 202 PRO – close PLBD ASAP
5. SM PL BAY DOORS
- R13L PL BAY DR SYS (two) – ENA
- CRT4 6. AC POWER ON – ITEM 1 EXEC
AUTO MODE SEL – ITEM 3 EXEC
PBD SW BYPASS – ITEM 14 EXEC
CLOSE – ITEM 17 EXEC
- If 'PLB SEQ FAIL' msg during door closure and aft latches for that door are not 'CL':
7. Check door scallop on or below tgt line before continuing in MAN mode; otherwise:
8. Perform MAL, MECH SSR-2, CONTINGENCY PLBD CLOSURE, then:
- After PLBD closed:
- CRT4 9. PBD STOP – ITEM 16 EXEC
AC POWER OFF – ITEM 2 EXEC
- R13L 10. PL BAY DR SYS (two) – DSBL
GPC/CRT 0/4 EXEC
- R11L 11. IDP/CRT4 PWR – OFF
- A7U 12. \sqrt PL BAY FLOOD (all) – OFF
If either H2O PUMP LOOP 1 A(B) – ON:
- MA73C:A 13. Leave MCA LOGIC MNA FWD 1
(MNB FWD 2) – ON in next step
- MA73C 14. MCA LOGIC MNA,B,C (fourteen) – OFF
15. Notify CDR: PLBDs closed

**LOSS OF 2 H2O LOOPS
ON-ORBIT
MS PAGE**

B10-18

OV105

OPCL/ALL/GEN M

MS OVHD PNL PWRDN

1. Set wrist watches as accurately as possible to MET (set one to GMT). The MET may be used for deorbit burn execution. Record GMT day of year
____/____:____:____
 2. Minimize Itg on Aft Flt Deck
 - O13:A 3. cb ESS 1BC MTU A – op
:C 2CA C/W B – op
 - O14:A 4. √BRAKES MNA – OFF
:B 5. cb MNA OI H2O BYP LOOP 1 SNSR – op
EVENT TIMER AFT – op
:E √ADTA 1 – op
DDU L,AFT (two) – op
 - O15:A 6. √BRAKES MNB – OFF
:B 7. cb MNB OI H2O BYP LOOP 2 SNSR – op
MSN TIMER AFT – op
EVENT TIMER FWD – op
:E √ADTA 2 – op
DDU L,R (two) – op
:F 8. MMU 2 – OFF
 - O16:A 9. √BRAKES MNC – OFF
:E 10. √cb MNC ADTA 3,4 (two) – op
DDU R – op
- When N2 QTY and TIG determined by CDR:
- O14:B 11. cb MNA OI MDM OF 1/2 A,3/4 A (two) – op
 - O15:B MNB OI MDM OF 1/2 B – op
 - O16:B MNC OI MDM OF 3/4 B – op
 - O14:F MMU 1 – OFF
 12. Notify CDR: MS OVHD PNL PWRDN complete
 13. Assist other MS with completion of PLB EQUIP PWRDN, 10-17

**LOSS OF 2 H2O LOOPS
ON-ORBIT
MS PAGE**

B10-19

OV105

OPCL/5/GEN M

When pwrdns complete, perform following at crew discretion:

FLUID LOADING PREP

- GALLEY
1. OVEN/RHS – ON
 2. Unstow, fill 4 water containers (per crewmember) with 8 oz of water each. Temp stow near seat
 3. Unstow 8 salt tablets (per crewmember). Temp stow in Flt Suit pocket
 4. OVEN/RHS – OFF
 5. √H2O HTRS (two) – OFF
 6. √OVEN FAN – OFF
 7. Stow Personal Hygiene Hose

NOTE

Ensure sufficient containers and salt tablets are prepared to continue fluid loading thru entry

FLUID LOADING

1. Immed begin drinking H2O (one 8-oz container every 15 min with a salt tablet in every other container) and continue through entry

CLOTHING CONFIG

1. Don QDM for temp > 90 degF and discomfort

FDF CONFIG

1. Unstow: ENT, ENT PKT, Deorb Burn Cards, ENT Cue Cards

CAB CONFIG

1. Stow loose equipment, Backup PGSC
2. Remove and stow side hatch UV filter, locking device, and pyro box safing pin
3. Tape foot loops in egress routes
4. Remove and stow Window Shades (if not needed for cab T control)

**LOSS OF 2 H2O LOOPS
ON-ORBIT
MS PAGE**

B10-20

OV105

OPCL/ALL/GEN M

WCS DEACT

- | | | |
|-------|----|--------------------------------------|
| WCS | 1. | Foot Restraints – up, locked |
| ML31C | 2. | √VAC VENT ISOL VLV CNTL – OP (tb-OP) |

INSTALL SEATS

POLE SETUP

1. ESCAPE POLE SETUP:
 - Reinstall Stbd pip pin and Large Port pin
 - Retract and hold Locking Pin(Ring)
 - Reinstall Large pin
 - Release Locking Pin(Ring)
 - Slide forward Safing latch
 - Verify pole straps secure
2. Check minimum lgt on Middeck

**LOSS OF 2 H2O LOOPS
ON-ORBIT
MS PAGE**

B10-21

OV105

OPCL/ALL/GEN M,6

This Page Intentionally Blank

**LOSS OF 2 H2O LOOPS
ON-ORBIT
MS PAGE**

B10-22

OV105

OPCL/ALL/GEN M

NOTE
KEEP THIS PAGE UNTIL TOUCHDOWN

MS After comm plan established with MCC, perform COMM
PWRDN ASAP (delay 10 min max)

CAUTION
Must complete steps 1 thru 3 within 10 min.
TDRS or STDN – HI AOS is limited to 10 min
or power amp will overheat

NOTE
Proc pwr off ALL ground comm

COMM PWRDN

- A1L 1. S-BD PM ANT SW ELEC – OFF
 PRE AMP – OFF
 PWR AMPL STBY – OFF
 OPER – OFF
 MODE sel – STDN LO
 XPNDR – OFF
2. NSP PWR – OFF
 ENCRYPTION PWR – OFF
 (Encrypt OFF rest of flt)
 MODE – SEL
 SEL – BYP

NOTE
Verify CDR ready for COMM PWRDN prior to
performing step 3

- C3 3. S-BD PM CNTL – PNL

NOTE
Ensure CDR has recorded N2 quantities before
powering down PCMMU. Other steps may be
performed

4. OI PCMMU PWR – OFF
 FORMAT – FXD
5. AUD CTR – OFF (turn ON as reqd for ICOM audio)

**LOSS OF 2 H2O LOOPS
ON-ORBIT
MS PAGE**

B10-23

OV105

OPCL/ALL/GEN M

NOTE
KEEP THIS PAGE UNTIL TOUCHDOWN

- | | | |
|--------|-----|---|
| O5 | 6. | L AUD PWR – OFF (turn ON as reqd for ICOM audio) |
| O6 | 7. | UHF MODE sel – OFF |
| O9 | 8. | R AUD PWR – OFF (turn ON as reqd for ICOM audio) |
| A1L | 9. | √S-BD PL CNTL – PNL
√PWR SYS – OFF |
| | 10. | PL DATA INTLVR PWR – OFF |
| A1R | 11. | S-BD FM CNTL – PNL
PWR – OFF |
| A3 | 12. | MON 1,2 PWR (two) – OFF |
| A7U | 13. | TV PWR CONTR UNIT – OFF |
| R14:B | 14. | cb MNA,MNC GCILC (two) – op |
| :D | | TV (fourteen) – op
MNB VPU – op |
| :E | | CAMR (six) – op |
| L9,R10 | 15. | PS,MS AUD PWR (two) – OFF |
| A13 | 16. | OS AUD SPKR PWR – OFF |
| MO42F | 17. | MIDDECK SPKR AUD SPKR PWR – OFF |
| | 18. | Call ground at every avail UHF site per COMM
POWERUP, 10-25; voice down cab temp, crew body
temps, heart rates, and words to indicate severity of cab
humidity |
- If MCC request data on cab environ or Av bays:
19. Perform CABIN ENVIRONMENT MONITOR (CONT DEORB, LOSS OF 2 H2O LOOPS), then:
- If after TIG-10 min:
20. Perform AFT PNL CONFIG FOR ENTRY COMM (CONT DEORB, LOSS OF 2 H2O LOOPS D/O PREP)

**LOSS OF 2 H2O LOOPS
ON-ORBIT
MS PAGE**

B10-24

OV105
OPCL/ALL/GEN M,3

NOTE
KEEP THIS PAGE UNTIL TOUCHDOWN

COMM POWERUP (If comm reqd prior to landing site coverage)

- Pwr up audio sys:
- C3 1. AUD CTR – 1
 - O5 L AUD PWR – AUD
 - O9 R AUD PWR – AUD
- If UHF avail, config for UHF comm (voice only):
- O6 2. UHF MODE sel – SPLX
√SPLX/EVA PWR AMPL – ON
 - 3. After comm with MCC complete: Go to COMM PWRDN, steps 5 thru 8, 10-23 >>
- If UHF site unavail or if MCC requests data (config for GSTDN(SGLS) S-BD):
- C3 4. √S-BD PM CNTL – PNL
 - A1L ANT SW ELEC – 2
MODE sel – STDN LO(SGLS)
XPNDR – 2
 - 5. NSP PWR – 2
√DATA RATE XMIT – HI
√RCV – HI
CODING XMIT – OFF
RCV – OFF
√UPLK DATA – S-BD
 - C3/F9 6. Sel best S-BD PM ANT
- If MCC requests data:
- O15:B : 7. cb MNB OI SIG CONDR OF 1/4 B, 2/3 A
: (two) – cl
 - O14:B : 8. cb MNA OI MDM OF 1/2 A, 3/4 A (two) – cl
 - C3 : 9. OI PCMMU PWR – 1
 - O6 : 10. MDM PL2 – ON
 - : 11. BFS, GNC I/O RESET
 - : At end of data transmission:
 - O14:B : 12. cb MNA OI MDM OF 1/2 A, 3/4 A (two) – op
 - O15:B : 13. cb MNB OI SIG CONDR OF 1/4 B, 2/3 A
: (two) – op
 - : If not reqd for PLBD CLOSURE:
 - O6 : 14. MDM PL2 – OFF
 - : After comm/data complete:
 - L 15. Go to COMM PWRDN, 10-23 >>

Cont next page

**LOSS OF 2 H2O LOOPS
ON-ORBIT
MS PAGE**

B10-25

OV105

OPCL/ALL/GEN M

NOTE
KEEP THIS PAGE UNTIL TOUCHDOWN

~
If UHF site and GSTDN unavail and comm/data critical:
Config for TDRS S-BD during AOS

CAUTION
This is a High Power Mode. On-time should be limited to 10 min max due to Pwr Amp Thermal constraints. A 3-min delay occurs before Pwr Amp comes on. Uplink not aff. Proceed with sel of best S-BD PM ANT

- C3
A1L
16. √S-BD PM CNTL – PNL
ANT SW ELEC – 2
PRE AMP – 2
PWR AMPL OPER – 2
MODE sel – TDRS DATA
XPNDR – 2
17. NSP PWR – 2
√DATA RATE XMIT – HI
√RCV – HI
CODING XMIT – ON
RCV – ON
√UPLK DATA – S-BD
- C3/F9
18. Sel best S-BD PM ANT
If MCC requests data:
- O15:B : 19. cb MNB OI SIG CONDR OF 1/4 B,2/3 A
: (two) – cl
- O14:B : 20. cb MNA OI MDM OF 1/2 A,3/4 A (two) – cl
- C3 : 21. OI PCMMU PWR – 1
- O6 : 22. MDM PL2 – ON
- : 23. BFS, GNC I/O RESET
- : At end of data transmission:
- O15:B : 24. cb MNB OI SIG CONDR OF 1/4 B,2/3 A
: (two) – op
- O14:B : 25. cb MNA OI MDM OF 1/2 A,3/4 A (two) – op
- : If not reqd for PLBD CLOSURE:
- O6 L 26. MDM PL2 – OFF
- After comm/data complete:
27. Go to COMM PWRDN, 10-23

**LOSS OF 2 H2O LOOPS
ON-ORBIT
MS PAGE**

B10-26

OV105

OPCL/ALL/GEN M

LOSS OF CAB PRESS

CDR Perform JOINT EXPEDITED UNDOCKING AND SEPARATION (SODF: JOINT OPS)
MS1,MS2 Perform procs on 10-30
PLT Perform following pwrdrn

NOTE

Cab press will stabilize at 8 psia for following EQ dP/dT values:

- < 0.6 for Orbiter + Airlock
- < 0.4 for Orbiter + Airlock + Spacehab.

If docked to ISS, undocking will be performed with Single G2 (i.e., no +Z redundancy)

- C3
1. MSTR MADS PWR – OFF
 2. Minimize ltg
 3. Use one IDP/CRT with two MDUs, as reqd (IDP4 preferable)
 4. Use one PGSC, FLT CNTLR PWR as reqd
- If FLT CNTLR PWR not reqd:
- O14,O15,
O16:E
5. cb DDU L,R,AFT (six) – op
- O7
6. \sqrt GPS 1,3 PWR (two) – OFF
- O8
7. \sqrt MLS (three) – OFF
 - \sqrt RDR ALTM (two) – OFF
- L1
8. CAB TEMP CNTLR – OFF
 9. HUM SEP (two) – OFF
 10. H2O LOOP 2(1) BYP MODE – MAN
MAN – DECR (30 sec)
 11. \sqrt FLOW PROP VLV LOOP tb (two) – ICH
- If FES not ena:
- : If EVAP OUT T 41 to 47 degF:
 - : | 12. RAD CNTLR OUT TEMP – HI
 - : | When EVAP OUT T > 50 degF:
 - : | 13. FLASH EVAP CNTLR PRI A(B) – ON, then
 - : | immed:
 - : | 14. RAD CNTLR OUT TEMP – NORM
 - : | If EVAP OUT T < 41 or > 47 degF:
 - : | 15. FLASH EVAP CNTLR PRI A(B) – ON
- L
16. \sqrt ANTISKID – OFF
- L2
- \sqrt NWS – OFF
- L4:L
17. cb Φ A CAB T CNTLR 1,2 (two) – op

Cont next page

B10-27

OV105

OPCL/5/GEN M

If orbit 2,3 deorbit due to cab leak:

18. Use DEORB PREP/ENTRY DELTAS PULLOUT PAGE, 10-31, then go to LAUNCH DAY DEORBIT PREP (ORBIT 2(3)) (CONT DEORB, LAUNCH DAY ORBIT 2(3)) >>

If orbit 3 deorbit due to fire, tox spill, or glass in cabin:

19. Go to LAUNCH DAY DEORBIT PREP (ORBIT 3) (CONT DEORB, LAUNCH DAY ORBIT 3) >>
- W1-10 20. Install Window Shades (ten) or mnvr to tail Sun att:
GNC UNIV PTG

TGT ID - ITEM 8 +4 EXEC
BODY VECT - ITEM 14 +5 EXEC
P - ITEM 15 +1 8 4 EXEC
Y - ITEM 16 +0 EXEC
OM - blank (MCC-provided if reqd)
DAP: A/AUTO/VERN
START TRK - ITEM 19 EXEC

C3
CRT

If time to TIG < 4 hr:

21. Go to 8 PSI DEORBIT PREP (DEORB PREP, CONTINGENCY DELTAS) >>

If time to TIG > 4 hr:

If currently in single G2 GPC OPS:

22. Perform G2 SET EXPANSION, target Dual G2 (ORB OPS, DPS), then:

Cont next page

B10-28

OV105

OPCL/ALL/GEN M,1

REASSIGN STRINGS TO GPC 2 IN MC 2

NOTE

If Av Bay 2 fire and TIG > 4 hr:
Reassign strings to GPC in unaffected
Av Bay

- CRT
O6
23. GNC 0 GPC MEMORY
CONFIG – ITEM 1 +2 EXEC
Modify MC 2 per table----->
DOWNLIST GPC –
ITEM 44 +2 EXEC
- | | |
|--------|-------|
| CONFIG | 2 |
| GPC | 02000 |
| STR 1 | 2 |
| 2 | 2 |
| 3 | 2 |
| 4 | 2 |
| PL 1/2 | 0 |
| CRT 1 | 2 |
| 2 | 2 |
| 3 | 0 |
| 4 | 2 |
| L 1 | 0 |
| 2 | 0 |
| MM 1 | 2 |
| 2 | 2 |
24. GNC, OPS 201 PRO
25. GPC MODE 1(3) – STBY
– HALT
– STBY
(tb-RUN)
– HALT
(tb-bp)
PWR 1(3) – OFF
√MODE 3,5 (two) –
HALT (tb-bp)
26. Go to 8 PSI DEORBIT PREP (DEORB PREP,
CONTINGENCY DELTAS)

MS PWRDN

CDR,MS1 Perform PLB EQUIP PWRDN (below)
MS2 Perform remaining pwrdn

- O14,O15, 1. cb ADTA (four) – op
O16:E
O16:E 2. cb MNC RCS/OMS PRPLT QTY GAUGE – op
If TIG > 2 hr 40 min:
O14:B 3. cb MNA EVENT TIMER AFT – op
O15:B 4. MNB MSN TIMER AFT – op
A7U 5. TV PWR CNTL – PNL
CONTR UNIT – OFF
A13 6. OS AUD SPKR PWR – OFF
L9 7. PS AUD PWR – OFF
MO42F 8. MIDDECK SPKR AUD SPKR PWR – OFF
MO58F 9. TV PWR – OFF
When RMS pwr dn:
A3 10. MON PWR (two) – OFF
R14:E 11. cb CAMR (six) – op
MD44F 12. Cab temp cntl act link – pin to FULL COOL, stow
linkage >>

PLB EQUIP PWRDN

13. If orbit 2,3 deorbit >>
14. Perform PL SAFING, then:

<p>CAUTION If stow prob occurs with either RMS and/or KU-BD ANT, perform aff sys <u>QUICK</u> <u>RESPONSE JETTISON (CONT DEORB)</u></p>
--

- If RMS grappled to OBSS:
15. Perform OBSS JETTISON (PDRS OPS FS, OBSS CONTINGENCY), then:
If RMS-only:
16. Perform RMS PWRDN (PDRS OPS), then:
If KU-BD ANT deployed:
17. Perform KU-BD ANT STOW (ORB OPS, COMM/INST), then:
If radiators deployed:
18. Go to RAD STOW (ORB OPS, ECLS)

**LOSS OF CAB PRESS
ON-ORBIT
MS PAGE**

B10-30

OV105

OPCL/ALL/GEN M,3

DEORB PREP/ENTRY DELTAS PULLOUT PAGE

NOTE

Incorporate following changes or remove this page for use with the indicated checklist or cue card.

Single fault tolerance used for most cab air-cooled equipment. Add'l LRUs may be activated if reqd and if CAB PRESS stable ≥ 8 psia

A. Deltas to the LAUNCH DAY ORBIT 2(3) (CONT DEORB)

1. Minimize use of IDPs, MDUs, FLT CNTLR PWR, DDUs. Use one PGSC
- If rev 3:
 2. ENT FWD FLT DECK CONFIG 10
Do not pwr MLS
 3. In ENT SW LIST/VER, do not activate pwrn items

B. Deltas to DEORBIT BURN (ENT)

At TIG-4:

1. Use two IDP/CRTs with four MDUs as reqd for deorbit burn
2. cb DDU L,R (four) – cl
3. L,R FLT CNTLR PWR (two) – ON

O14,O15,
O16:E
F6,F8

C. Deltas to POST BURN (ENT)

1. Use one IDP/CRT with two MDUs as reqd
2. L,R FLT CNTLR PWR (two) – OFF
3. cb DDU L,R,AFT (six) – op
4. Delete ANTISKID, NWS callouts (ENTRY SW CHECK)

F6,F8
O14,O15,
O16:E

At EI-15:

5. GPS 3 PWR – ON
PRE AMPL (two) – ON
Wait 30 sec
GNC I/O RESET
GNC 55 GPS STATUS
INIT – ITEM 16 EXEC
NAV – ITEM 19 EXEC

O7

Cont next page

**LOSS OF CAB PRESS
D/O PULLOUT PAGE**

B10-31

OV105

OPCL/5/GEN M

D. Deltas to ENTRY MANEUVERS (Cue Card)

At EI:

O14,O15,
O16:E
F6,F8
O14,O15,
O16:E

1. Use two IDP/CRTs with four MDUs as reqd
2. cb DDU L,R (four) – cl
3. L,R FLT CNTLR PWR (two) – ON
4. cb ADTA 1,2,3 (three) – cl
5. BFS, GNC I/O RESET

At V = 15K:

If CAB P < 8 psia:

6. Delete NAV AIDS callout

If CAB P ≥ 8 psia:

7. Activate all RAs, MLSs
GNC I/O RESET

At M < 1.0, go to step 10

At M = 2.7:

8. Use two HUDs, MLSs, and RAs as reqd
9. GNC I/O RESET

At M < 1.0:

L2

10. ANTISKID – ON
11. NWS – 1

LOSS OF HI LOAD EVAP

NOTE

MAL, ECLS SSR-2, FES CORE FLUSH PROCEDURE should be performed if core icing is suspected. If unsuccessful, perform pwrn prior to RAD BYPASS at TIG-2:50 during deorb prep. If already in deorb prep, perform pwrn and review activities already performed for changes

- C3 1. √MSTR MADS PWR – OFF
2. Minimize Itg
3. Use one IDP/CRT with two MDUs, one FLT CNTLR PWR, and one PGSC as reqd
4. Perform PL PWRDN, then:
If not in deorb prep:
- O7 5. √GPS 1,3 PWR (two) – OFF
√PRE AMPL (four) – OFF
- O8 6. √RDR ALTM (two) – OFF
7. √MLS (three) – OFF
- L1 8. √FLOW PROP VLV LOOP tb (two) – ICH
9. √HI LOAD DUCT HTR sel – OFF
- A3 10. TV MON (two) – OFF
If FLT CNTLR PWR not reqd:
- O14,O15, O16:E 11. cb DDU L,R,AFT (six) – op
12. Reset EVAP OUT T C&W upper limit (ch 107,117) to 2.15V (70 degF). Change B/U C&W parameter, 0631207, 0631407 upper limit to 70
- A. Deltas to NOMINAL DEORBIT PREP (DEORB PREP) if not already performed
At TIG-03:00, prior to RAD BYP:
- L1 1. H2O LOOP 2(1) BYP MODE – MAN
MAN – DECR (hold 30 sec)
FLASH EVAP CNTLR PRI A – OFF
B – OFF
SEC – ON
√HI LOAD EVAP – OFF
Perform RAD BYPASS/FES C/O (ORB OPS, ECLS):
Delete steps 3 and 5 thru 8 (SEC FES C/O)
At TIG-03:15 in DED DISP ENT CONFIG:
2. Do not pwr NAV/LDG AIDS, ADTAs
Pwr DDUs, MDUs only as reqd

Cont next page

B10-33

OV105

OPCL/5/GEN M

At TIG-01:50, ENT SWITCH LIST/VERIF:

3. Do not pwr NAVAIDS, ADTAs
Delete BRAKE/ANTISKID ACT
4. Go to LOSS OF HI LOAD EVAP DEORB OR
ENTRY PULLOUT PAGE (ENT PKT, PWRDN)

B. Deltas to DEORBIT BURN (ENT)

At TIG-10:

- O14,O15,
O16:E
1. cb DDU L,R (four) – cl
 2. Use two IDP/CRTs with four MDUs, and two FLT
CNTLR PWR for burn

At TIG-5:

- L1
3. TOP EVAP HTR NOZ (two) – OFF
DUCT sel – OFF

C. Deltas to POST BURN (ENT)

- F6,F8
O14,O15,
O16:E
1. L,R FLT CNTLR PWR (two) – OFF
 2. cb DDU L,R (four) – op (save for entry)
 3. Use one IDP/CRT with two MDUs
 4. Delete ANTISKID, NWS callouts (ENTRY SW
CHECK)

D. Deltas to ENTRY MANEUVERS (Cue Card)

At EI:

- O14,O15,
O16:E
F6
O14,O15,
O16:A
O14,O15,
O16:E
L2
1. cb DDU L,R (four) – cl
 2. L FLT CNTLR PWR – ON
 3. Use two IDP/CRTs with four MDUs
 4. BRAKES (three) – ON
 5. cb ADTA 1,2,3 (three) – cl
 6. GNC I/O RESET
 7. NWS – 1
 8. ANTISKID – ON

At M = 2.7:

9. Use two HUDs, MLSs, and RAs
10. GNC I/O RESET

OV105

OPCL/5/GEN M

LOSS OF 1 FREON LOOP

- MS Perform MS PWRDN, 10-36
- C3 1. MSTR MADS PWR – OFF
2. Minimize Itg
3. Use one IDP/CRT with two MDUs as reqd, and one PGSC
- If FLT CNTLR PWR not reqd:
- O14,O15,
O16:E 4. cb DDU L,R,AFT (six) – op
- L1 5. If reqd, perform PL PWRDN, then:
6. √FLOW PROP VLV LOOP tb (two) – ICH
7. H2O LOOP 2(1) BYP MODE – MAN
MAN – DECR (hold 30 sec)
- SM SYS SUMM 2**
- If EVAP OUT T not ~39 degF and stable:
8. Perform TOPPING FES STARTUP (ORB OPS, ECLS), then:
- If prior to deorb prep:
- If dual or triple G2:
9. Perform G2 SET CONTRACTION (ORB OPS, DPS) to single G2, then:
- O15:F
W1-10 10. MMU 2 – OFF
11. Mnvr to shade windows from sun or install Window Shades
- SM SYS SUMM 1**
12. Check kW; if >14 kW: Perform PRIOR PWRDN (numbered) (except FES and one PGSC) until ≤ 14 kW, then:
13. Use UNDOCKING/DEORB/ENTRY DELTAS PULLOUT PAGE, 10-37, for changes to UNDOCKING/DEORB PREP and ENT >>
- If in deorb prep:
- F6,F8 14. √FLT CNTLR PWR (two) – OFF
15. Use one IDP/CRT with two MDUs, as reqd
- O7 16. GPS 1,3 PWR (two) – OFF
PRE AMPL (four) – OFF
- O8 17. RDR ALTM (two) – OFF
18. MLS (three) – OFF
- L2 19. ANTISKID – OFF
NWS – OFF
20. Continue with DEORB PREP; use UNDOCKING/DEORB/ENTRY DELTAS PULLOUT PAGE, 10-37, for changes

OV105

B10-35

OPCL/5/GEN M

MS PWRDN

1. Minimize Itg on Aft Flt Deck and Middeck
 - R14:D 2. cb TV (fifteen) – op
 - :E 3. CAMR (six) – op
 - A3 4. MON 1,2 PWR (two) – OFF
- If in deorb prep:
- O14,O15, 5. BRAKES (three) – OFF
 - O16:A
 - O14,O15, 6. cb ADTA (four) – op
 - O16:E

OV105

B10-36

OPCL/ALL/GEN M,6

UNDOCKING/DEORB/ENTRY DELTAS PULLOUT PAGE

NOTE

KEEP THIS PAGE UNTIL TOUCHDOWN.

Incorporate following changes or remove these pages for use with the indicated checklist or cue card.

Undocking from ISS will be performed with Single G2 (i.e., no +Z redundancy)

Perform NOMINAL DEORBIT PREP (DEORB PREP) with the following contingency deltas to the procedure

A. Deltas to DEORB PREP

1. Use one FLT CNTLR PWR, DDU, PGSC, and one IDP/CRT with two MDUs, as reqd
2. Minimize Itg
3. Minimize sun in cab if possible

If rev 3 deorb, deltas to LAUNCH DAY ORBIT 3 (CONT DEORB):

4. ENT FWD FLT DECK CONFIG 10
Do not pwr MLS

If nominal deorb prep:

Deltas to NOMINAL DEORBIT PREP (DEORB PREP):

5. Verify steps 14 thru 20, 10-35, MS, steps 7,8, 10-36
6. DED DISP ENT CONFIG 6
Do not pwr ADTAs
Add: Pwr NAV/LDG AIDS per ENTRY MANEUVERS (Cue Card)
Minimize MDU use
7. ENT SWITCH LIST/VERIF
Do not pwr LRUs previously pwr dn

B. Deltas to DEORBIT BURN (ENT)

1. Maintain window shading att until TIG-15

At TIG-15:

2. Remove Window Shades if installed

At TIG-10:

3. cb DDU L,R (four) – cl
4. Use two IDP/CRTs with four MDUs, two FLT CNTLR PWR for burn

Cont next page

**LOSS OF 1 FREON LOOP
PULLOUT PAGE**

B10-37

OV105

OPCL/5/GEN M

- F6,F8
O14,O15,
O16:E
- C. Deltas to POST BURN (ENT)
1. L,R FLT CNTLR PWR (two) – OFF
 2. cb DDU L,R (four) – op
 3. Use one IDP/CRT with two MDUs
 4. Delete ANTISKID, NWS callouts (ENTRY SW CHECK)

O7

At EI-15:

5. GPS 3 PWR – ON
PRE AMPL (two) – ON
Wait 30 sec
GNC I/O RESET
GNC 55 GPS STATUS
INIT – ITEM 16 EXEC
NAV – ITEM 19 EXEC

- O14,O15,
O16:E
F6
- D. Deltas to ENTRY MANEUVERS (Cue Card)
At EI:

1. cb DDU L,R (four) – cl
2. L FLT CNTLR PWR – ON
3. Use two IDP/CRTs with four MDUs
4. BRAKES (three) – ON

O14,O15,
O16:A
O14,O15,
O16:E

cb ADTA 1,2,3 (three) – cl

L2

GNC I/O RESET
ANTISKID – ON
NWS – 1

- At V = 12K:
5. Perform RAD FLOW in unfailed loop
- At M = 2.7:
6. Use two HUDs, MLSs, and RAs
GNC I/O RESET

- E. Deltas to POST LDG (ENT)
If EVAP OUT T high and incr, go to EMER PWRDN
(Cue Card)

- L1
- F. Deltas to EVAP OUT TEMP HIGH (Cue Card)
If EVAP OUT T HIGH and V > 12K:
Establish RAD FLOW in unaff loop:
1. RAD BYP VLV MODE 1(2) – AUTO
CNTLR LOOP 1(2) – AUTO A(B)
 2. Perform EVAP OUT T HIGH (Rads Coldsoaked), steps 2 thru 4

- If EVAP OUT T HIGH and V < 12K:
If loop 1(2) lost:
3. NH3 CNTLR B(A) – PRI/GPC
- L1

**LOSS OF 1 FREON LOOP
PULLOUT PAGE**

B10-38

OV105
OPCL/5/GEN M

LOSS OF 1 FC

- If before deorb prep:
- L1 1. √CAB FAN A(B) – ON
 - If total Orb kW > 18:
 - 2. Perform PRIOR PWRDN, GROUP 1,2 (except FES), then:
 - 3. Perform PL PWRDN
 - If FC 1 or 2 failed:
 - R1 4. √MN BUS TIE A,B (two) – ON
√C – OFF
 - If FC 3 failed:
 - 5. PL PRI MNB – ON
MNC – OFF
FC3 – OFF
 - 6. √MN BUS TIE C,A (two) – ON
√B – OFF
 - If any FC AMPS > 330 or ΔAMPS > 100:
 - 7. Perform MAL, EPS SSR-8, BUS LOADING – LRU SELECT, then:
 - 8. Go to step 18
 - If in deorb prep:
 - 9. Minimize Itg
 - 10. Use only one DDU, and FLT CNTLR PWR as reqd.
One IDP/CRT off as reqd
 - O7 11. GPS 1,3 PWR (two) – OFF
PRE AMPL (four) – OFF
 - O8 12. RDR ALTM (two) – OFF
 - 13. MLS (three) – OFF
 - L1 14. √CAB FAN A(B) – ON
 - R14:D 15. cb TV (fifteen) – op
:E CAMR (six) – op
 - A3 16. MON 1,2 PWR (two) – OFF
 - A11 17. CRYO TK HTR (four) – OFF
 - If FC recoverable:
 - 18. Go to MAL, EPS SSR-3, FC SHUTDN C&W LIMIT CHANGE >>
 - If FC unrecoverable:
 - 19. Make FDF Delta changes as given (next page), then as time permits reconfig C/W limits per MAL, EPS SSR-3, FC SHUTDN C&W LIMIT CHANGE

Cont next page

B10-39

OV105

OPCL/5/GEN M,3

FDf changes:

- A. Deltas to DEORBIT BURN (ENT)
TIG-5:
- L1 1. TOP EVAP HTR NOZ (two) – OFF
DUCT sel – OFF
HI LOAD DUCT HTR sel – OFF
HUM SEP (two) – OFF
- L2 FLASH EVAP FDLN HTR SPLY (two) – OFF
- B. Deltas to POST BURN (ENT)
At EI-15:
- O7 1. GPS 1,3 PWR (two) – ON
PRE AMPL (four) – ON
Wait 30 sec
GNC I/O RESET
GNC 55 GPS STATUS
INIT – ITEM 14,16 EXEC
NAV – ITEM 17,19 EXEC
- O8 2. MLS (three) – ON
3. RDR ALTM (two) – ON
- C. Deltas to EPS procs in this book
1. FC REACTANT VLV CLOSED: Delete step 6;
Change step 2 to read:
If aff FC/MN bus tied and COOL P > 40:
 2. MN BUS TIE (three) – ON (ASAP)
(Aff) MN BUS TIE (one) – OFF (ASAP)
 2. FC COOL P: Delete step 1
 3. BUS TIE, steps 1,7: Delete '(A to...A)'
 4. FC1(2,3) H2 PUMP $\uparrow\downarrow$: Replace step 3 with:
If aff FC/MN bus tied:
 3. MN BUS TIE (three) – ON
(Aff) MN BUS TIE (one) – OFF
 5. FC SAFING: Replace steps 7,8 with:
If aff FC/MN bus tied:
 7. MN BUS TIE (three) – ON
8. (Aff) MN BUS TIE (one) – OFF
 6. FC H2O RLF NOZ TEMP $\uparrow\downarrow$: Replace step 3 with:
If aff FC/MN bus tied:
 3. MN BUS TIE (three) – ON
(Aff) MN BUS TIE (one) – OFF
 7. FC DELTA V 1(2,3):
Delete step 1
Add 'MN BUS TIE (three) – ON, then:' to
beginning of step 4

Cont next page

B10-40

OV105

OPCL/5/GEN M

- ┌ | | | ┌
- D. Deltas to EPS (ENT PKT)
 - 1. Perform LOSS OF 1 FC, part B, steps 1 thru 8 (ENT PKT, PWRDN), then:
If in deorb prep:
 - 2. Go/return to NOMINAL DEORBIT PREP (DEORB PREP) >>

 - E. Deltas to FLIGHT PLAN at 10 min prior to 'Go to DEORB PREP', add: 'perform LOSS OF 1 FC, steps 9 thru 17 (ORB PKT, PWRDN)'

This Page Intentionally Blank

B10-40b

OV105

OPCL/5/GEN M

LOSS OF 2nd FC ON-ORBIT (TIG < 4 hr)

If Rev 2,3 deorbit:

1. Go to LOSS OF 2nd FC (ASC PKT, PWRDN) >>
2. If TIG < 1.5 hr: Sel new TIG > 1.5 hr
(this pwrdn and the deorbit prep require 1.5 hr)

NOTE

Do NOT perform BUS LOSS ACTION unless bus shorted (step 29 regains bus)

- * FC capability is ~12 kW for sustained operations, *
- * ~13 kW for short duration (~4 hr), ~16 kW for *
- * contingency situations (~10 min). Purge FC at *
- * 430 amps or less *

- MS 3. Perform AFT PNL PWRDN, 10-43, immed
- C3 4. √MSTR MADS PWR – OFF
5. Minimize Itg
6. Use only one DDU, PGSC, and FLT CNTLR PWR as reqd. One IDP/CRT off as reqd
- O7 7. GPS PWR (three) – OFF
PRE AMPL (six) – OFF
- O8 8. √RDR ALTM (two) – OFF
- MS 9. √MLS (three) – OFF

If GPC 2 on:

10. GNC 0 GPC MEMORY

CONFIG – ITEM 1 +2 EXEC

Modify MC 2 per table ---->

For any IDP that is OFF:

11. GPC/CRT1/X EXEC
- CRT 12. √DOWNLIST GPC (ITEM 44) – 1
GNC, OPS 201 PRO
- O6 13. GPC MODE 2 – STBY (tb-bp)
– HALT
PWR 2 – OFF
14. √MODE 3,5 (two) – HALT
(tb-bp)
PWR 3 – OFF
- O15:F 15. √MMU 2 – OFF

	CONFIG	2
	GPC	10000
STR	1	1
	2	1
	3	1
	4	1
PL	1/2	0
CRT	1	1
	2	1
	3	0
	4	1
L	1	0
	2	0
MM	1	1
	2	1

Cont next page

B10-41

OV105

OPCL/5/GEN M

16. GNC 20 DAP CONFIG
 Sel TAIL PRI P,Y OPTION
 Sel PRI JETS
- O7 17. AFT L,R RCS MANF ISOL 4 (two) – CL
 O14,O15, 18. RJDF DRIVER (four) – OFF
 O16:F LOGIC (four) – OFF
 O6 19. MDM FF4 – OFF
 O14:F 20. RJDA 2A L4/R4 DRIVER – OFF
 LOGIC – OFF
- L1 21. $\sqrt{\text{FLOW PROP VLV LOOP tb}}$ (two) – ICH
 22. SM 88 APU/ENVIRON THERM
 23. H2O LOOP 2 BYP MODE – MAN
 MAN – INCR(DECRC)
 (adjust until ICH FLOW ~950)
- If no MANF leak:
 R1 24. $\sqrt{\text{O2,H2 MANF VLV}}$ (four) – OP
 TK1 HTRS B – AUTO (MNA or MNB ↓) or
 TK2 HTRS B – AUTO (MNC or no
 MN BUS ↓), then:
 All others OFF
- If MANF leak:
 25. $\sqrt{\text{O2/H2 HTR LOSS TABLE (EPS)}}$, 5-20
 Sel one htr in one O2,H2 TK
- R2 26. HYD CIRC PUMP (three) – OFF
 L4:L 27. cb AC1,2 Φ A CAB T CNTLR 1,2 (two) – op
 If not MN bus short, tie three MN BUSES:
 28. Perform BUS TIE (Cue Card), then:
 Post BUS TIE config check:
- L1 29. $\sqrt{\text{CAB FAN A(B)}}$ – ON
 30. Perform RCS SECURE, FWD RCS only (RCS), 8-2,
 then:
 31. Perform MAL, EPS SSR-3, FC SHUTDN C&W LIMIT
 CHANGE, then:
 32. Go to LOSS OF 2 FC (CONT DEORB). Refer to
 Activities Priority Table for activities to be performed in
 the CONT DEORB

OV105

B10-42

OPCL/ALL/GEN M

AFT PNL PWRDN

- A11 1. CRYO TK HTR (four) – OFF
- A12 2. APU HTR LUBE OIL LN (three) – OFF
- 3. HYD HTR (eight) – OFF
- A14 4. RCS/OMS HTR FWD RCS – OFF
- 5. RCS JET (five) – OFF
- 5. Perform PL SAFING, then:

CAUTION
If stow prob occurs with either RMS and/or
KU-BD ANT, perform aff sys QUICK
RESPONSE JETTISON (CONT DEORB)

If RMS grappled to OBSS:

- 6. Perform OBSS JETTISON (PDRS OPS FS,
OBSS CONTINGENCY), then:

If RMS-only:

- 7. Perform RMS PWRDN (PDRS OPS), then:

If KU-BD ANT deployed:

- 8. Perform KU-BD ANT STOW (ORB OPS,
COMM/INST), then:

If radiators deployed:

- 9. Perform RAD STOW (ORB OPS, ECLS), then:

- A3 10. MON PWR (two) – OFF
- R14:D 11. cb TV (fifteen) – op
- :E CAMR (six) – op
- ML86B:C 12. √cb MNB EXT AIRLK HTR VEST Z1/2/3 – op

If MMU is pwr:

- :D 13. cb MNA MMU PORT HTR A – op
- STBD HTR A – op
- MNB MMU PORT HTR B – op
- STBD HTR B – op

- MD44F 14. Cab temp cntl act link – pin to FULL COOL

**LOSS OF 2nd FC
ON-ORBIT (TIG < 4 hr)
MS PAGE**

B10-43

OV105

OPCL/ALL/GEN M,6

This Page Intentionally Blank

**LOSS OF 2nd FC
ON-ORBIT (TIG < 4 hr)
MS PAGE**

B10-44

OV105

OPCL/ALL/GEN M

LOSS OF 2nd FC ON-ORBIT (TIG > 4 hr)

NOTE

Do NOT perform BUS LOSS ACTION unless bus shorted (step 8 regains bus).

If docked with ISS, perform PWRDN completely prior to undocking

- * FC capability is ~12 kW for sustained operations, *
- * ~13 kW for short duration (~4 hr), ~16 kW for *
- * contingency situations (~10 min). Purge FC at *
- * 430 amps or less *

- | | |
|-------|--|
| MS | 1. Perform MS OVHD AND AFT PNL PWRDN, 10-47, immed |
| O3 | 2. <input checked="" type="checkbox"/> MSTR MADS PWR – OFF
<u>GNC 21 IMU ALIGN</u> |
| | 3. IMU 1,2 (two) – desel
If GPC 2(3) on: |
| | 4. <u>GNC 0 GPC MEMORY</u>
CONFIG – ITEM 1 +2 EXEC
Modify MC 2 per table ----> |
| | <input checked="" type="checkbox"/> DOWNLIST GPC
(ITEM 44) – 1 |
| CRT | GNC, OPS 201 PRO
For any IDP that is OFF: |
| O6 | 5. GPC/CRT1/X EXEC
6. GPC MODE 2 – STBY (tb-bp)
– HALT
PWR 2 – OFF
<input checked="" type="checkbox"/> MODE 3,5 (two) – HALT
(tb-bp)
<input checked="" type="checkbox"/> PWR 3 – OFF |
| O15:F | 7. MMU 2 – OFF
If not MN bus short, tie three MN buses: |
| | 8. Perform BUS TIE (EPS), 5-16, then: |
| | 9. Minimize Itg |
| | 10. Use one DDU, PGSC, and FLT CNTLR PWR as reqd.
Use one IDP/CRT with four MDUs |
| O7 | 11. GPS PWR (three) – OFF
PRE AMPL (six) – OFF |
| O8 | 12. <input checked="" type="checkbox"/> RDR ALTM (two) – OFF
13. <input checked="" type="checkbox"/> MLS (three) – OFF |

	CONFIG	2
	GPC	10000
STR	1	1
	2	1
	3	1
	4	1
PL	1/2	0
CRT	1	1
	2	1
	3	0
	4	1
L	1	0
	2	0
MM	1	1
	2	1

Cont next page

B10-45

OV105

OPCL/5/GEN M

- L1 14. $\sqrt{\text{FLOW PROP VLV LOOP tb (two) - ICH}}$
 15. AV BAY 2 FAN A,B (two) - OFF
 16. $\sqrt{\text{CAB FAN A(B) - ON}}$
- L4:L 17. cb AC1,2 Φ A CAB T CNTLR 1,2 (two) - op
 18. Perform GG FREE DRIFT, ATT ID B (mnvr in PRI, establish drift in VERN) (ORB OPS, RCS), then:
 If docked with ISS, have ISS establish mated att control
- O14,O15, O16:F 19. Set event timer for 30 min (for FES duct htr deact)
 O6 20. RJD LOGIC,DRIVER (seventeen) - OFF
- L1 21. MDM FF1,FF2,FF4 (three) - OFF
 FA1,FA2,FA3,FA4 (four) - OFF
 22. TOP EVAP HTR NOZ L,R (two) - OFF
 23. $\sqrt{\text{HI LOAD DUCT HTR sel - OFF}}$
 24. SM 88 APU/ENVIRON THERM
 25. H2O LOOP 2 BYP MODE - MAN
 MAN - INCR(DECR)
 (adjust until ICH FLOW ~950)
- R1 If no MANF leak:
 26. $\sqrt{\text{O}_2\text{,H}_2\text{ MANF VLV (four) - OP}}$
 TK1 HTRS B - AUTO (MNA or MNB \downarrow) or
 TK2 HTRS B - AUTO (MNC or no
 MN BUS \downarrow), then:
 All others OFF
- If MANF leak:
 27. $\sqrt{\text{O}_2\text{/H}_2\text{ HTR LOSS TABLE (EPS), 5-20}}$
 Sel one htr in one O2,H2 TK
- R2 28. BLR CNTLR/HTR (three) - OFF
 29. HYD CIRC PUMP (three) - OFF
- R4 30. Verify RMS, KU-BD ANT, and RADS stowed, then:
 MA73C:A, B MCA LOGIC (fourteen) - OFF
- :A If H2O LOOP 2 failed:
 31. MCA LOGIC MNB FWD 2 - ON
 30 min after FES deact:
- L1 32. TOP EVAP HTR DUCT sel - OFF
 33. Perform MAL, EPS SSR-3, FC SHUTDN C&W LIMIT CHANGE, then:
 If docked with ISS, perform UNDOCKING DELTAS prior to undocking
 34. Go to LOSS OF 2 FC (CONT DEORB)

OV105

B10-46

OPCL/ALL/GEN M

MS OVHD AND AFT PNL PWRDN

- O14:A 1. IMU 1 – OFF (confirm IMU desel)
- O15:A 2. 2 – OFF (confirm IMU desel)
- O16:E 3. cb MNC RCS/OMS PRPLT QTY GAUGE – op
- R14:D 4. TV (fifteen) – op
- A11 5. CRYO TK HTR (four) – OFF
- A12 6. APU HTR LUBE OIL LN (three) – OFF
- 7. HYD HTR (eight) – OFF
- A14 8. RCS/OMS HTR FWD RCS JET 1,2,3,4 (four) – OFF
- ML31C 9. VAC VENT NOZ HTR – OFF
- ML86B:A 10. cb MNA H2O LN HTR A – op
- 11. MNB H2O LN HTR B – op
- :C 12. √cb MNB EXT AIRLK HTR VEST Z1/2/3 – op
- If MMU is pwrd:
- :D 13. cb MNA MMU PORT HTR A – op
- STBD HTR A – op
- MNB MMU PORT HTR B – op
- STBD HTR B – op
- MD44F 14. Cab temp cntl act link – pin to FULL COOL
- 15. Perform PL SAFING, then:

CAUTION
If stow prob occurs with either RMS and/or
KU-BD ANT, perform aff sys QUICK
RESPONSE JETTISON (CONT DEORB)

If RMS grappled to OBSS:

- 16. Berth OBSS or perform OBSS JETTISON (PDRS OPS FS, OBSS CONTINGENCY), then:

If RMS-only:

- 17. Perform RMS PWRDN (PDRS OPS), then:

If KU-BD ANT deployed:

- 18. Perform KU-BD ANT STOW (ORB OPS, COMM/INST), then:

If radiators deployed:

- 19. Perform RAD STOW (ORB OPS, ECLS), then:

20. Report to CDR: RMS, KU-BD ANT, and RADS stowed

- O14:F 21. MMU 1 – OFF
- R14:E 22. cb CAMR (six) – op
- A3 23. MON PWR (two) – OFF

**LOSS OF 2nd FC
ON-ORBIT (TIG > 4 hr)
MS PAGE**

B10-47

OV105

OPCL/ALL/GEN M,6

UNDOCKING DELTAS

NOTE

Following steps reqd to recover RCS
functionality prior to undock

- | | | |
|----------|----|---|
| | 1. | One hour prior to undock: |
| A14 | | RCS/OMS HTR FWD RCS JET 1,2,3,4 (four) – ON |
| O14,O15, | 2. | RJD LOGIC,DRIVER (seventeen) – ON |
| O16:F | | |
| O6 | 3. | MDM FF1,FF2,FA1,FA2 (four) – ON |

After undocking complete and post Final Sep:

- | | | |
|----------|----|---|
| | 4. | Perform GG FREE DRIFT, ATT ID B (mnvr in PRI.
Establish drift in VERN) (ORB OPS, <u>RCS</u>), then: |
| O14,O15, | 5. | RJD LOGIC,DRIVER (seventeen) – OFF |
| O16:F | | |
| O6 | 6. | MDM FF1,FF2,FA1,FA2 (four) – OFF |
| A14 | 7. | RCS/OMS HTR FWD RCS JET 1,2,3,4 (four) – OFF |

**LOSS OF 2nd FC
ON-ORBIT (TIG > 4 hr)
MS PAGE**

B10-48

OV105

OPCL/ALL/GEN M

LOSS OF 2 FREON LOOPS

WARNING

FC purge must be started and loads pwr'd dn ASAP

Orbiter lifetime is expected to be 120 min from LOSS OF 2nd FREON LOOP with all three FCs running. This assumes three FCs are pwr'd dn to a total level of 8 kW immed and are continuously purged

Earliest possible landing is req'd

NOTES

- Failure assumed to occur after GO for On-orbit and before Deorbit TIG-2:05
- COMM procs, 10-65 thru 10-68, should be used throughout this proc and CONT DEORB
- Preferred comm config is:
 - A. UHF only
 - B. GSTDN S-BD if req'd
 - C. TDRS only if mandatory
- If docked to ISS, this proc is to be worked simo with JOINT EXPEDITED UNDOCKING AND SEPARATION (SODF: JOINT OPS)

Cont next page

B10-49

OV105

OPCL/ALL/GEN M

TIME CRITICAL PROCEDURES

NOTE

Undocking will be performed with Single G2
(i.e., no +Z redundancy)

1. If in OPS 1: Go to LOSS OF 2 FREON LOOPS (POST OMS-2)
(ASC PKT, PWRDN) >>
2. Have CDR perform JOINT EXPEDITED UNDOCKING AND
SEPARATION (SODF: JOINT OPS)
3. Have MS exec RAD STOW, KU-BD ANT STOW, and PLBD
CLOSE, 10-57, ASAP
4. Have second MS exec RMS STOW and MS OVHD AND AFT PNL
CONFIG, 10-59 thru 10-62, ASAP
5. Have third MS exec COMM PWRDN, 10-65; delay 10 min max if
AOS

Perform following steps ASAP:

O14,O15, 6. $\sqrt{\text{Pri}}$ RJD LOGIC,DRIVER (sixteen) – ON
O16:F

DAP: ALT (this proc results in loss of VERNs)

O16:F RJD MANF L5/F5/R5 DRIVER – OFF

7. Record MET of failure of 2nd FREON LOOP:

_____/_____:_____:_____

C3 8. MSTR MADS PWR – OFF

MS R11U 9. $\sqrt{\text{FC}}$ PURGE HTR – ON

10. $\sqrt{\text{VLVS}}$ 1,2,3 (three) – OP

11. Minimize Itg

CRTX 12. Use only one fwd IDP/CRT with one MDU (save IDP3
for entry)

13. Use only one PGSC

F6/F8 14. $\sqrt{\text{FLT}}$ CNTLR PWR (two) – OFF, as reqd

Cont next page

B10-50

OV105

OPCL/ALL/GEN M

Config GPC 1 to MC 2:

15. GNC 0 GPC MEMORY
 16. CONFIG – ITEM 1 +2 EXEC
- If not GNC 201, then:
17. GNC, OPS 201 PRO
 18. Modify MC 2 per table

CONFIG	2
GPC	10000
STR	1
	2
	3
	4
PL	1/2
CRT	1
	2
	3
	4
L	1
	2
MM	1
	2

NOTE

The following must be an OPS mode recall:
GNC, OPS 201 PRO

For any IDP that is OFF:

19. GPC/CRT1/X EXEC
20. \sqrt BFC CRT DISP – OFF
21. GPC MODE 2,3 (two) – STBY (tb-bp), HALT
– STBY (tb-RUN)
– HALT (tb-bp)
PWR 2,3 (two) – OFF
MODE 5 – STBY (tb-RUN)
– HALT (tb-bp)
OUTPUT 5 – NORM
PWR 5 – OFF
22. GPS PWR (three) – OFF
PRE AMPL (six) – OFF
23. \sqrt RDR ALTM (two) – OFF
24. \sqrt MLS (three) – OFF
25. FCS CH (four) – AUTO
26. MPS MANF PRESS (two) – CL
27. HYD CIRC PUMP (three) – OFF
28. MPS He ISOL (six) – CL
PNEU He ISOL – CL
L ENG He XOVR – CL
29. HUM SEP (two) – OFF
30. \sqrt IMU FAN B – ON
A,C (two) – OFF

C3
O6

O7

O8

C3

R4

R2

L1

Cont next page

B10-51

OV105

OPCL/5/GEN M

- MD44F 31. Cab temp cntl act link – pin to FULL COOL
L1 32. CAB FAN A,B (two) – OFF
33. √AV BAY 1 FAN A – OFF
√2,3 FAN A,B (four) – OFF
√1 FAN B – ON
34. FREON PUMP LOOP 1,2 (two) – OFF (one-ON,
if any flow)
35. RAD CNTLR LOOP 1,2 (two) – OFF
36. √NH3 CNTLR A,B (two) – OFF
If no FREON PUMPS ON, then:
L2 37. O2 SYS 1,2 SPLY (two) – OP (tb-OP)
L1 38. FLASH EVAP CNTLR PRI A,B (two) – OFF
TOP EVAP HTR NOZ (two) – OFF
DUCT sel – OFF
L2 39. HI LOAD DUCT HTR sel – OFF
40. FLASH EVAP FDLN HTR SPLY (two) – OFF
If one FREON PUMP ON:
L1 41. FLASH EVAP CNTLR PRI A – ON
42. TOP EVAP HTR NOZ (two) – OFF
√DUCT sel – ON
L2 43. √HI LOAD DUCT HTR sel – ON
44. FLASH EVAP FDLN HTR B SPLY – OFF
45. √ANTISKID – OFF
46. √NWS – OFF
O6 47. S TRK PWR -Y,-Z (two) – OFF
48. ANNUN BUS SEL ACA 2/3 – OFF
GNC 21 IMU ALIGN
49. IMU 1,2 (two) – desel
– OFF
O14,
O15:A
- CAUTION**
Do not perform steps 50 thru 56
until PLBDs are closed
- C2 50. IDP/CRT MAJ FUNC (three) – GNC
O6 51. GPC MODE 4 – STBY (tb-bp)
– HALT
PWR 4 – OFF
GNC 0 GPC MEMORY
52. CONFIG – ITEM 1 +2 EXEC
53. Assign PL1/2 to GPC 1 (provides Uplk path)
54. GNC, OPS 201 PRO

Cont next page

B10-52

OV105

OPCL/ALL/GEN M

- 55. All IDPs,MDUs – OFF (use one IDP/CRT with one MDU as reqd until CONT DEORB proc, 3 min OFF for each min ON)
- O6 56. MDM FF1,4 (two) – OFF
FA1,4 (two) – OFF
- F6 57. CDR disp sws – green dot

NOTE

If no site avail, bailout will be reqd; TIG will = MET of 2nd FREON LOOP failure + 1 hr

- 58. Sel ELS TIG \leq 1 hr after MET of 2nd FREON LOOP failure (from MCC or PGSC):
 - Selected TIG ___:___:___ MET
 - (-) Present TIME ___:___:___ MET
 - (=) Time to TIG ___:___:___ MET

If PL MDMs not currently being used for comm:

- 59. Verify PLBDs are closed, then:
 - √MDM PL1,PL2 (two) – OFF
- O6 L4:J 60. cb AC3 Φ A SIG CONDR HUM SEP – op
 Φ B SIG CONDR IMU FAN – op
- :L 61. AC1 Φ A CAB T CNTLR 2 – op
 Φ B AV BAY 2 S/C – op
- 62. AC2 Φ A CAB T CNTLR 1 – op
 Φ B AV BAY 3 S/C – op
- R1 63. MN BUS TIE (three) – ON
- 64. √O2,H2 MANF VLV TK1,TK2 (four) – op
TK2 HTRS A,B (four) – OFF
TK1,TK3 HTRS A,B (eight) – AUTO

If O2 TK1(TK3) QTY < 80%:

- 65. O2 TK1,TK3 HTRS A (two) – OFF
- R2 66. BLR CNTLR/HTR 2 – OFF
PWR 2 – OFF

If not docked with ISS or when undocking complete and Post Final Sep:

- 67. Perform POST UNDOCKING AND FINAL SEP RECONFIG, 10-55
- 68. Go to ENTRY CONFIG (CONT DEORB, LOSS OF 2 FREON LOOPS D/O PREP) by ~ TIG-15 >>

OV105

This Page Intentionally Blank

B10-54

OV105

OPCL/ALL/GEN M

POST UNDOCKING AND FINAL SEP RECONFIG

1. DAP: FREE
2. RJD LOGIC,DRIVER (seventeen) – OFF
O14,O15,
O16
3. cb MNA OI SIG CONDR OF 1/4 A – op
O14:B
4. cb MNB OI SIG CONDR OF 1/4 B – op
O15:B
5. cb MNC OI SIG CONDR OF 2/3 A – op
O16:B
6. cb MNC OI SIG CONDR OF 2/3 B – op
O14,O15,
O16:E

This Page Intentionally Blank

B10-56

OV105

OPCL/ALL/GEN M

MS PULLOUT PAGE

MS Execute ASAP

- R11U
1. FC PURGE HTR – ON
VLVS (three) – OP
 2. Minimize ltg on Aft Flt Deck

NOTE

For following RAD STOW, KU-BAND ANT STOW, and PLBD CLOSE procs, use the following MCA config. Disregard MCA sw throws in other procs until PLB doors closed

MCA LOGIC CONFIG

- MA73C:A, 3. ✓All MCA LOGIC (fourteen) – ON
B
:A 4. MCA LOGIC MNA FWD 1 – ON
MNB FWD 2 – OFF
MID 1 – OFF
MNC FWD 3 – OFF
:B MNA AFT 1 – OFF
MNB AFT 2 – OFF
MID 3 – OFF
MNC AFT 3 – OFF
5. GNC 23 RCS
ITEM 1 EXEC (FRCS page)
OVRD FRCS MANF(s) – OP

CAUTION

If stow prob occurs with KU-BD ANT, perform QUICK RESPONSE JETTISON (CONT DEORB)

If KU-BD ANT deployed:

6. Perform KU-BD ANT STOW (ORB OPS, COMM/INST), then:

If radiators deployed:

7. Perform RAD STOW (ORB OPS, ECLS), then:

Cont next page

**LOSS OF 2 FREON LOOPS
ON-ORBIT
MS PAGE**

B10-57

OV105

OPCL/ALL/GEN M,6

PLBD CLOSURE

WARNING
Verify no obstructions before closing and
latching PLBD (Ku ANT,RAD,RMS,etc)

- O6 1. √MDM PL1,PL2 (two) – ON
SM I/O RESET
- CRT4 2. Verify PL SAFING complete
- CRT4 3. SM, OPS 202 PRO – close PLBD ASAP
- 4. SM PL BAY DOORS
- R13L 5. PL BAY DR SYS 1,2 (two) – ENA
- CRT4 6. AC POWER ON – ITEM 1 EXEC
AUTO MODE SEL – ITEM 3 EXEC
PBD SW BYPASS – ITEM 14 EXEC
CLOSE – ITEM 17 EXEC
- If 'PLB SEQ FAIL' msg during door closure and aft latches
: for that door are not 'CL':
: 7. Check door scallop on or below tgt line before
: continuing in MAN mode; otherwise:
: 8. Perform MAL, MECH SSR-2,
L CONTINGENCY PLBD CLOSURE, then:
9. PBD STOP – ITEM 16 EXEC
- 10. AC POWER OFF – ITEM 2 EXEC
GPC/CRT 04 EXEC
- R11L 11. IDP/CRT4 PWR – OFF
- R13L 12. PL BAY DR SYS (two) – DSBL
- A7U √FLOOD (all) – OFF
- MA73C:A, 13. All MCA LOGIC sw except MNA FWD 1 (thirteen)
B – OFF
:A √MCA LOGIC MNA FWD 1 – ON
- 14. GNC 23 RCS
ITEM 1 EXEC (FRCS page)
OVRD FRCS MANF(s) – OP
- 15. Report to CDR: RMS, KU-BD ANT, and RADS stowed;
PLBD closed
- 16. Go to FLUID LOADING PREP, 10-63

**LOSS OF 2 FREON LOOPS
ON-ORBIT
MS PAGE**

B10-58

OV105

OPCL/ALL/GEN M

RMS STOW

NOTE

For following RMS STOW, use following MCA config. Disregard MCA sw throws in other procs until PLB doors closed

- MA73C:A, 1. √MCA LOGIC MNA MID 1 – ON
B √3 – ON
√MNB MID 2 – ON
√4 – ON
√MNC MID 2 – ON
√4 – ON
2. Perform PL SAFING, then:

CAUTION

If stow prob occurs with RMS, perform QUICK RESPONSE JETTISON (CONT DEORB)

If RMS grappled to OBSS:

3. Perform OBSS JETTISON (PDRS OPS FS, OBSS CONTINGENCY), then:

If RMS-only:

4. Perform RMS PWRDN (PDRS OPS), then:

MS OVHD AND AFT PNL CONFIG

- O13:A 1. cb ESS 1BC C/W A – op
:B CRYO QTY O2,H2 TK2 (two) – op
:C 2CA C/W B – op
(all SM tones and C/W lights and tones lost; CRT
FAULT SUMM and SM ALERT light remains)
cb ESS 2CA MTU B – op
:E 3AB GPC STAT – op
- O14:A 2. √BRAKES MNA – OFF
3. √RGA 1 – OFF
:B 4. cb MNA OI SIG CONDR OM 1/2 A – op
MDM OF 1/2 A – op
3/4 A – op
H2O BYP LOOP 1 SNSR – op
MSN TIMER FWD – op
EVENT TIMER AFT – op

Cont next page

**LOSS OF 2 FREON LOOPS
ON-ORBIT
MS PAGE**

B10-59

OV105

OPCL/ALL/GEN M

O14:C 5. cb MNA UTIL PWR O19/MO52J – op
:D FREON RAD CNTLR 1,2 (two) – op
O2/N2 CNTLR 1 – op (leave cl if PCS 1 active)
CAB VENT – op
VENT ISOL – op
:E √ADTA 1 – op
√ACCEL 1 – op
DDU L,AFT (two) – op
:F 6. MMU 1 – OFF
7. ASA 1 – OFF
O15:A 8. √BRAKES MNB – OFF
9. √RGA 2 – OFF
4 – OFF
:B 10. cb MNB OI MDM OF 1/2 B – op
H2O BYP LOOP 2 SNSR – op
MSN TIMER AFT – op
EVENT TIMER FWD – op
:C UTIL PWR F1/MO13Q – op (leave cl if
PGSC reqd)
:D FREON RAD CNTLR 1,2 (two) – op
O2/N2 CNTLR 2 – op (leave cl if PCS 2 active)
:E ADTA 2 – op
ACCEL 2 – op
DDU L,R (two) – op
:F 11. MMU 2 – OFF
12. ASA 2 – OFF
13. ACCEL 4 – OFF
O16:A 14. √BRAKES MNC – OFF
15. √RGA 3 – OFF
:B 16. cb MNC OI MDM OF 3/4 B – op
AUX TIMING BUFF – op
:C 17. CRYO O2 HTR TK2 SNSR 1 – op
If GALLEY:
18. cb MNC UTIL PWR A11/A15/MO30F – op

Cont next page

**LOSS OF 2 FREON LOOPS
ON-ORBIT
MS PAGE**

B10-60

OV105

OPCL/ALL/GEN M

- | | | |
|-------|-----|---------------------------------------|
| O16:C | 19. | cb MNC ANNUN AFT ACA 4/5 – op |
| | | O2 EMER – op |
| :E | | ADTA 3,4 (two) – op |
| | | DDU R,AFT (two) – op |
| | | RCS/OMS PRPLT QTY GAUGE – op |
| :F | 20. | ASA 3,4 (two) – OFF |
| | 21. | ACCEL 3 – OFF |
| O17:A | 22. | ATVC (four) – OFF |
| :B | 23. | EIU (three) – OFF |
| :C | 24. | SIG CONDR FREON A,B (two) – OFF |
| :D | | OA 1/2/3 – OFF |
| | 25. | MDM OA 1/2/3 – OFF |
| | 26. | MEC 1 – OFF, wait 2 sec, then |
| | | 2 – OFF |
| MO58F | 27. | TV PWR – OFF |
| O19 | 28. | COAS – OFF |
| A11 | 29. | CRYO TK4 HTR O2,H2 A,B (four) – OFF |
| A12 | 30. | APU HTR GAS GEN/FU PUMP 2 – OFF |
| | | LUBE OIL LN 1,2,3 (three) – OFF |
| | | APU HTR TK/FU LN/H2O SYS |
| | | 1B,2A,2B,3A (four) – OFF |
| | | 1A,3B (two) – AUTO |
| | 31. | HYD HTR (eight) – OFF |
| A13 | 32. | OS AUD SPKR PWR – OFF |
| A14 | 33. | RCS/OMS HTR FWD RCS – OFF |
| | | L,R POD (four) – OFF |
| | | OMS CRSFD LN (two) – OFF |
| | | FWD RCS JET (five) – OFF |
| | | AFT RCS JET (five) – OFF |
| A15 | 34. | PTU/MAIN BUS A,B (two) – OFF (tb-OFF) |
| A6U | 35. | FLT CNTLR PWR – OFF, as reqd |
| | 36. | ANNUN BUS SEL – OFF |

Cont next page

**LOSS OF 2 FREON LOOPS
ON-ORBIT
MS PAGE**

B10-61

OV105

OPCL/5/GEN M,2

R14:A	37.	cb MNA ADC 1A/2A – op MNB ADC 1B/2B – op
:B		MNA,MNB,MNC PALLET DSC (three) – op
:D	38.	TV (fifteen) – op
:E		CAMR (six) – op
L9,R10	39.	PS,MS AUD PWR (two) – OFF
	40.	Minimize Middeck lgt
ML31C	41.	VAC VENT NOZ HTR – OFF
ML86B:A	42.	cb MNB H2O LN HTR B – op
		If MMU is pwrd:
:D	43.	cb MNA MMU PORT HTR A – op STBD HTR A – op MNB MMU PORT HTR B – op STBD HTR B – op
MO39M	44.	MIDDECK COMM CCU PWR – OFF
MO42F		SPKR AUD PWR – OFF
		If no GALLEY:
	45.	Go to step 48
GALLEY	46..	OVEN/RHS – OFF H2O HTR (two) – OFF √OVEN FAN – OFF
	47.	Go to step 50
	48.	FOOD WARMER – OFF
	49.	H2O DISPENSER PWR pb – OFF
MD44F	50.	Cab temp cntl act link – pin to FULL COOL
MO13Q	51.	All MIDDECK lts – lt off

OV105

B10-62

OPCL/5/GEN M,3

FLUID LOADING PREP

- GALLEY
1. OVEN/RHS – ON
 2. Unstow, fill 4 water containers (per crewmember) with 8 oz of water each. Temp stow near seat
 3. Unstow 8 salt tablets (per crewmember). Temp stow in Flt Suit pocket
 4. OVEN/RHS – OFF
 5. ✓H2O HTR (two) – OFF
 6. ✓OVEN FAN – OFF
 7. Stow Personal Hygiene Hose

NOTE

Ensure sufficient containers and salt tablets are prepared to continue fluid loading thru entry

FLUID LOADING

Immed (or as soon as time permits), begin drinking H2O (one 8-oz container every 15 min with a salt tablet in every other container); continue thru entry

CLOTHING CONFIG

Don QDM for temp > 90 degF and discomfort. If cab temp > 95 degF and no evaporative cooling is sensed, don LES, check tabs, close visor, LES O2 – ON

NOTE

Inflate anti-g suit as needed for on-orbit circulatory support

FDF CONFIG

1. Unstow: ENT, ENT PKT, ENT Cue Cards
2. Use DEORBIT BURN MONITOR and ENTRY MANEUVERS Cue Card (CONT DEORB, LOSS OF 2 FREON LOOPS D/O PREP)

CAB CONFIG

1. Stow loose equipment
After Deorbit Targeting complete:
 2. Stow Backup PGSC
 3. Remove and stow Side hatch UV filter, locking device, and pyro box safing pin
 4. Tape foot loops in egress routes
 5. Remove and stow Window Shades (if not needed for cab T control)

**LOSS OF 2 FREON LOOPS
ON-ORBIT
MS PAGE**

B10-63

OV105

OPCL/ALL/GEN M

WCS DEACT

- | | | |
|-------|----|-------------------------------------|
| WCS | 1. | Foot Restraints – up, locked |
| ML31C | 2. | VAC VENT ISOL VLV CNTL – CL (tb-CL) |

POLE SETUP

Perform ESCAPE POLE STOWAGE/SETUP (Cue Card), then:

SEAT INSTALLATION

1. Confirm minimum lftg on Middeck
2. Unstow LOSS OF 2 FREON LOOPS D/O PREP (CONT DEORB);
perform MS PAGE procs

**LOSS OF 2 FREON LOOPS
ON-ORBIT
MS PAGE**

B10-64

OV105

OPCL/ALL/GEN M,6

NOTE

The COMM PWRDN and POWERUP procs on this and following pages should be used until Touchdown

COMM PWRDN

- MS Pwr dn comm ASAP after comm with MCC no longer reqd. Delay 10 min max if AOS. Use COMM POWERUP, 10-67, if MCC comm reqd. Comm will be pwrd on entry by AFT PNL CONFIG FOR ENTRY COMM, MS PULLOUT PAGE (CONT DEORB, LOSS OF 2 FREON LOOPS D/O PREP) and special ENTRY MANEUVERS Cue Card
- A1L 1. S-BD PM ANT SW ELEC – OFF
PRE AMP – OFF
PWR AMPL STBY – OFF
OPER – OFF
MODE sel – STDN LO
XPNDR – OFF
2. NSP PWR – OFF
ENCRYPTION PWR – OFF
(Encrypt disabled rest of flt)
ENCRYPTION MODE – SEL
SEL – BYP
- C3 3. S-BD PM CNTL – PNL,CMD
OI PCMMU FORMAT – FXD
PWR – OFF
AUD CTR – OFF (pwr up as reqd for cockpit audio)
- A1L 4. √S-BD PL CNTL – PNL
√PWR SYS – OFF
PL DATA INTLVR PWR – OFF
- A1R 5. S-BD FM CNTL – PNL
PWR – OFF
- A3 6. MON PWR (two) – OFF
A7U 7. TV PWR CONTR UNIT – OFF
O6 8. UHF MODE sel – OFF
9. MDM PL1,PL2 (two) – OFF
R12L 10. VTR PWR – OFF
R14:B 11. cb MNA,MNC GCILC (two) – op

Cont next page

**LOSS OF 2 FREON LOOPS
ON-ORBIT
MS COMM PAGE**

B10-65

OV105

OPCL/ALL/GEN M

NOTE

During each comm window, voice down cab temp, crew body temps and heart rates, per COMM POWERUP, 10-67; indicate severity of cab humidity

If after TIG-10:

12. Go to AFT PNL CONFIG FOR ENTRY COMM, MS PULLOUT PAGE (CONT DEORB, LOSS OF 2 FREON LOOPS D/O PREP)

**LOSS OF 2 FREON LOOPS
ON-ORBIT
MS COMM PAGE**

B10-66

OV105

OPCL/ALL/GEN M

COMM POWERUP (If comm reqd prior to landing site coverage)

Pwr up audio sys:

C3 1. AUD CTR – 1
O5 √L AUD PWR – AUD
O9 √R AUD PWR – AUD

If UHF avail, config for UHF comm (voice only):

O6 2. UHF MODE sel – SPLX
√SPLX/EVA PWR AMPL – ON
3. After comm with MCC complete: Go to COMM
PWRDN, 10-65 >>

If UHF site unavail or if MCC requests data
(config for GSTDN(SGLS) S-BD):

C3 4. √S-BD PM CNTL – PNL
A1L ANT SW ELEC – 2
MODE sel – STDN LO(SGLS)
XPNDR – 2

5. NSP PWR – 2
DATA RATE XMIT – HI
RCV – HI
CODING XMIT – OFF
RCV – OFF
√UPLK DATA – S-BD

C3/F9 6. Sel best S-BD PM ANT

If MCC requests data:

O14:B : 7. cb MNA OI MDM OF 1/2 A,3/4 A (two) – cl
O17:D : 8. SIG CONDR OA 1/2/3 – ON
: 9. MDM OA 1/2/3 – ON
C3 : 10. OI PCMMU PWR – 1
O6 : 11. MDM PL2 – ON
: 12. GNC I/O RESET
: At end of data transmission:
O14:B : 13. cb MNA OI MDM OF 1/2 A,3/4 A (two) – op
O17:D : 14. SIG CONDR OA 1/2/3 – OFF
: 15. MDM OA 1/2/3 – OFF
: After comm/data complete:
L 16. Go to COMM PWRDN, 10-65

Cont next page

**LOSS OF 2 FREON LOOPS
ON-ORBIT
MS COMM PAGE**

B10-67

OV105

OPCL/ALL/GEN M

↑
If UHF site and GSTDN unavail and comm/data critical:
Config for TDRS S-BD:

CAUTION

This is a High Pwr Mode. On-time should be limited to 10 min max due to Pwr Amp Thermal constraints. A 3-min delay occurs after S-BD PM PNL/CMD before Pwr Amp is active. Uplink not affected. Proceed with selection of best antenna

- C3 17. √S-BD PM CNTL – PNL
- A1L 18. √ANT SW ELEC – 2
 - √PRE AMP – 2
 - √PWR AMPL OPER – 2
 - MODE sel – TDRS DATA
 - √XPNDR – 2
- 19. √NSP PWR – 2
 - √DATA RATE XMIT – HI
 - RCV – HI
 - CODING XMIT – ON
 - RCV – ON
 - √UPLK DATA – S-BD
- C3/F9 20. Sel best S-BD PM ANT
- If MCC requests data:
 - O14:B : 21. cb MNA OI MDM OF 1/2 A,3/4 A (two) – cl
 - O17:D : 22. SIG CONDR OA 1/2/3 – ON
 - : 23. MDM OA 1/2/3 – ON
 - C3 : 24. OI PCMMU PWR – 1
 - O6 : 25. MDM PL2 – ON
 - : 26. GNC I/O RESET
 - : At end of data transmission:
 - O14:B : 27. cb MNA OI MDM OF 1/2 A,3/4 A (two) – op
 - O17:D : 28. SIG CONDR OA 1/2/3 – OFF
 - L 29. MDM OA 1/2/3 – OFF
- After comm/data complete:
 - 30. Go to COMM PWRDN, 10-65

**LOSS OF 2 FREON LOOPS
ON-ORBIT
MS COMM PAGE**

B10-68

OV105

OPCL/ALL/GEN M

LOSS OF FES

- MS Perform MS PWRDN, 10-71, immed
- O3 1. $\sqrt{\text{MSTR MADS PWR}} - \text{OFF}$
2. Minimize Itg
3. Use one PGSC, and one IDP/CRT with two MDUs only as reqd
- If FLT CNTLR PWR not reqd:
O14,O15, O16:E 4. cb DDU L,R,AFT (six) – op
- If not in deorb prep:
O7 5. $\sqrt{\text{GPS 1,3 PWR (two)}} - \text{OFF}$
 $\sqrt{\text{PRE AMPL (four)}} - \text{OFF}$
- O8 6. $\sqrt{\text{RDR ALTM (two)}} - \text{OFF}$
7. $\sqrt{\text{MLS (three)}} - \text{OFF}$
8. Perform PL PWRDN, then:
- L1 9. CAB TEMP CNTLR – OFF
10. H2O LOOP 2 BYP MODE – MAN
MAN – DECR (hold 30 sec)
PUMP LOOP 1 (two) – OFF, B
11. $\sqrt{\text{FLOW PROP VLV LOOP tb (two)}} - \text{ICH}$
12. $\sqrt{\text{TOP EVAP HTR NOZ L,R (two)}} - \text{OFF}$
 $\sqrt{\text{DUCT sel}} - \text{OFF}$
- L2 13. $\sqrt{\text{HI LOAD DUCT HTR sel}} - \text{OFF}$
14. $\sqrt{\text{NWS}} - \text{OFF}$
15. $\sqrt{\text{ANTISKID}} - \text{OFF}$
- L4:L R2 16. cb CAB T CNTLR 1,2 (two) – op
17. BLR CNTLR/HTR (three) – OFF
- MMU 2 deact:
18. SM 1 DPS UTILITY
 $\sqrt{\text{MMU ASSIGN 1 SM}} - \text{ITEM 3 EXEC}$
MMU 2 – OFF
- O15:F If IMU ALIGN not reqd, mnvr to tail Sun att:
19. GNC UNIV PTG
TGT ID – ITEM 8 +4 EXEC
BODY VECT – ITEM 14 +5 EXEC
P – ITEM 15 +1 8 4 EXEC
Y – ITEM 16 +0 EXEC
OM – ITEM 17 +9 0 EXEC ($\beta < 0$)
+2 7 0 EXEC ($\beta > 0$)
START TRK – ITEM 19 EXEC
20. Confirm MS pwrnd activities complete, then:
For deorbit prep:
21. Go to LOSS OF FES (CONT DEORB)

OV105

B10-69

OPCL/5/GEN M

This Page Intentionally Blank

B10-70

OV105

OPCL/ALL/GEN M

MS PULLOUT PAGE

MS2 Deploy rads, RAD DEPLOY (ORB OPS, ECLS)
MS1 Perform pwrn below

MS PWRDN

1. Minimize Itg
- O14, O15, O16:A 2. √BRAKES (three) – OFF
- O14, O15, O16:E 3. √cb ADTA (four) – op
- O14:B 4. MSN TIMER FWD – op
EVENT TIMER AFT – op
- O15:B 5. MSN TIMER AFT – op
EVENT TIMER FWD – op
- A1L 6. PL DATA INTLVR PWR – OFF
- A12 7. APU HTR LUBE OIL LN (three) – OFF
8. HYD HTR (eight) – OFF
- A14 9. RCS/OMS HTR FWD RCS – OFF
L,R POD (four) – OFF
OMS CRSFD LN (two) – OFF
- R14:D 10. cb TV (fifteen) – op
:E CAMR (six) – op
- A3 11. MON 1,2 PWR (two) – OFF
- ML31C 12. VAC VENT NOZ HTR – OFF
- If Manned Mnv Unit is pwrn:
- ML86B:D 13. cb MNA,MNB STBD HTR A,B (two) – op
PORT HTR A,B (two) – op
- MD44F 14. Cab temp cntl act link – pin to FULL COOL

LOSS OF FES
ON-ORBIT
MS COMM PAGE

B10-71

OV105

OPCL/ALL/GEN M,3

This Page Intentionally Blank

**LOSS OF FES
ON-ORBIT
MS COMM PAGE**

B10-72

OV105
OPCL/ALL/GEN M

AV BAY FIRE

AV BAY 1

NOTE

While performing proc, note any cbs open.

Equipment still pwr'd in Av Bay following pwr'dn:

FPCA 1	MDM OF1
FLCA 1	DSC OF1
IMU FAN	ACCU

If docked with ISS, proc results in loss of Lo Z Translation.

If no active GNC GPC: Perform GNC RECOVERY VIA G2FD (DPS), 3-12, concurrent with remainder of this proc

- R1 1. cb AC CONTR AC1 (three) – cl
 2. INV/AC BUS 1 – OFF (tb-OFF)
 INV PWR 1 – OFF (tb-OFF)
 3. cb AC CONTR AC1 (three) – op
 4. Perform FC1 SHUTDN, except PWRDN (Cue Card),
 then:
- L1 5. √AV BAY 1 FAN A,B (two) – OFF
 6. FREON PUMP LOOP 2 – A
 7. AV BAY 3 FAN A – ON
 B – OFF
- C3 8. OI PCMMU FORMAT – FXD
 PWR – 2
9. BFC CRT DISP – ON
- O6 10. √GPC PWR 5 – ON
 √OUTPUT 5 – NORM
 MODE 5 – STBY (tb-RUN), RUN
 11. 4 – STBY (tb-bp), HALT
 PWR 4 – OFF
- If GNC RECOVERY VIA G2FD (DPS), 3-12, performed:
 12. Go to step 15
- If Single G2 GPC OPS:
 13. Perform G2 SET EXPANSION, target Dual G2
 (ORB OPS, DPS), then:
- If/when in Multiple GPC OPS:
 14. Reassign strings to GPC 2 in MC 2
 GNC 0 GPC MEMORY

Cont next page

B10-73

OV105

OPCL/ALL/GEN M

CRT	CONFIG – ITEM 1 +2 EXEC Modify MC 2 per table----> DOWNLIST GPC – ITEM 44 +2 EXEC	CONFIG 2 GPC 02000
O6	15. GNC, OPS 201 PRO GPC MODE 1(3) – STBY (tb-bp) – HALT PWR 1 – OFF	STR 1 2 2 2 3 2 4 2 PL 1/2 0 CRT 1 2 2 2 3 0 4 2
O7	16. MDM FF1 – OFF PL1 – OFF 17. Perform PL PWRDN, then: 18. √GPS 1 PWR – OFF √PRE AMPL (two) – OFF	L 1 0 2 0 MM 1 2 2 2
O8	19. √RDR ALTM 1 – OFF 20. √MLS 1 – OFF 21. <u>GNC 23 RCS</u>	
CRT	RCS FWD – ITEM 1 EXEC (*) MANF VLVS STAT OVRD – ITEM 41 EXEC – CL (MANF 2)	
O13:A :E	22. cb ESS 1BC AC1 SNSR – op 3AB GPC STAT – op	
O14:A :E	23. √BRAKES MNA – OFF 24. cb MNA RDR ALTM 1 – op MLS 1 – op √ADTA 1 – op √ACCEL 1 – op	
:F	25. MMU 1 – OFF 26. RJDF 1B F1 LOGIC – OFF DRIVER – OFF	
O15:F	27. RJDF 1A F2 LOGIC – OFF DRIVER – OFF 28. √ACCEL 4 – OFF	
O16:A :E	29. √BRAKES MNC – OFF 30. √cb MNC ADTA 3 – op	
A1R	31. PL DATA INTLVR PWR – OFF 32. S-BD PL CNTL – PNL,CMD	
MA73C:A AW18H A12	33. MCA LOGIC MNA FWD 1 – OFF 34. √PWR/BATT CHGR EMU 1,2 BUS SEL (two) – OFF 35. HYD CIRC PUMP PWR 1 – MNB 2 – MNC 3 – MNA	

Cont next page

B10-74

OV105

OPCL/5/GEN M,2

- L4:G 36. cb AC2 Φ A, Φ B, Φ C AV BAY 1 FAN B (three) – op
 37. Perform MAL, EPS SSR-110, BUS LOSS: AC1, except:
 L1 \sqrt AV BAY 1 FAN A,B (two) – OFF, then:
 38. Reassign SM into GPC 3, per MAL, DPS SSR-4, SM REASSIGNMENT
 39. Perform LOAD PCMMU FORMAT, using TFL 161/103 (ORB OPS FS, COMM/INST), then:
- C3 40. BFC CRT DISP – OFF
 SEL – 3+1
- O6 Check all IDPs deassigned from BFS
 GPC MODE 5 – STBY,HALT (tb-bp)
 \sqrt OUTPUT 5 – NORM
- For deorb prep:
 If orbit 3 deorbit:
 41. Go to LAUNCH DAY DEORBIT PREP (ORBIT 3) (CONT DEORB) >>
 42. Perform MAL, ECLS SSR-12, AV BAY FIRE RECOVERY/RECONFIG, Checkout and Recovery, then:
- For deorb prep:
 If orbit 7 deorbit:
 43. Perform P&I nominal POST INSERTION, DEORB PREP (POST INSERT, ORBIT 7 D/O), then:
 44. Go to AV BAY FIRE (DEORB PREP, CONTINGENCY DELTAS)

OV105

B10-75

OPCL/5/GEN M,2

This Page Intentionally Blank

B10-76

OV105

OPCL/ALL/GEN M

AV BAY 2

NOTE

While performing proc, note any cbs open.

Equipment still pwr'd in Av Bay following pwr'dn:

FPCA 2 MDM OF2
FLCA 2 DSC OF2
BFC 3A (When GPC 3 is powered).

If docked with ISS, proc will require ISS to control mated attitude or result in loss of mated attitude control. Proc also results in loss of Lo Z Translation

- | | | |
|-----|-----|---|
| R1 | 1. | cb AC CONTR AC2 (three) – cl |
| | 2. | INV/AC BUS 2 – OFF (tb-OFF)
INV PWR 2 – OFF (tb-OFF) |
| | 3. | cb AC CONTR AC2 (three) – op |
| | 4. | Perform <u>FC2 SHUTDN</u> , except PWRDN (Cue Card),
then: |
| L1 | 5. | IMU FAN A(C) – ON
B – OFF |
| | 6. | AV BAY 1 FAN A – ON
B – OFF |
| | 7. | FREON PUMP LOOP 1 – A |
| | 8. | √CAB FAN A – ON
√B – OFF |
| | 9. | √AV BAY 2 FAN A,B (two) – OFF |
| C3 | 10. | √OI PCMMU PWR – 1 |
| A1L | 11. | √S-BD PM MODE sel – TDRS DATA
√NSP DATA RATE XMIT – HI
√RCV – HI
√CODING XMIT – ON
√RCV – ON
√PWR – 1
√UPLK DATA – S-BD |
| C3 | 12. | S-BD PM CNTL – PNL,CMD |

Cont next page

B10-77

OV105

OPCL/ALL/GEN M

REASSIGN STRINGS TO GPC 1 IN MC 2

CRT	13.	<u>GNC 0 GPC MEMORY</u> CONFIG – ITEM 1 +2 EXEC Modify MC 2 per table---->	CONFIG	2
			GPC	10000
O6	14.	GNC, OPS 201 PRO	STR	1
	15.	GPC MODE 2 – STBY(tb-bp)		1
		– HALT		1
		PWR 2 – OFF		1
		√MODE 5 – HALT	PL	1/2
		√OUTPUT 5 – NORM		0
		√PWR 5 – OFF	CRT	1
	16.	MDM FF2,FF4 (two) – OFF		1
		PL2 – OFF		0
				1
O8	17.	Perform PL PWRDN, then:	L	1
	18.	√RDR ALTM 2 – OFF		0
	19.	√MLS 2,3 (two) – OFF		0
O13:C	20.	cb ESS 2CA AC2 SNSR – op	MM	1
O15:A	21.	√BRAKES MNB – OFF		1
:E	22.	cb MNB RDR ALTM 2 – op		
		MLS 2 – op		
		√ADTA 2 – op		
		√ACCEL 2 – op		
:F	23.	MMU 2 – OFF		
O14,O15,	24.	√RJDA LOGIC,DRIVER (eight) – ON		
O16:F				
	25.	<u>GNC 20 DAP CONFIG</u> – sel tail only P,Y OPTION – ITEM 15,16 EXEC (TAIL) – ITEM 35,36 EXEC (TAIL)		
	26.	DAP: PRI		
O16:A	27.	√BRAKES MNC – OFF		
:E	28.	cb MNC MLS 3 – op		
		√ADTA 4 – op		
:F	29.	RJDF 2A F3 LOGIC – OFF		
		DRIVER – OFF		
		2B F4/F5 LOGIC – OFF		
		F4 DRIVER – OFF		
	30.	√ACCEL 3 – OFF		
	31.	RJD MANF L5/F5/R5 DRIVER – OFF		
A1L	32.	S-BD PL PWR SYS – OFF		
		CNTL – PNL,CMD		

Cont next page

B10-78

OV105

OPCL/5/GEN M,2

A12

33. √HYD CIRC PUMP PWR 1 – MNA
2 – MNB
3 – MNC

MA73C:A
L4:H

34. MCA LOGIC MNB FWD 2 – OFF
35. cb AC3 AV BAY 2 FAN B (three) – op
36. Perform MAL, EPS SSR-120, BUS LOSS: AC2, except:
L1 √AV BAY 2 FAN A,B (two) – OFF, then:
37. Reassign BFS into GPC 3, per MAL, DPS SSR-7, GPC IPL MENU OPTION (PASS/BFS)

For deorb prep:

If orbit 3 deorbit:

38. Go to LAUNCH DAY DEORBIT PREP (ORBIT 3) (CONT DEORB) >>
39. Perform MAL, ECLS SSR-12, AV BAY FIRE RECOVERY/RECONFIG, Checkout and Recovery, then:

For deorb prep:

If orbit 7 deorbit:

40. Perform Deltas to nominal POST INSERTION, DEORB PREP (POST INSERT, ORBIT 7 D/O), then:
41. Go to AV BAY FIRE (DEORB PREP, CONTINGENCY DELTAS)

OV105

B10-79

OPCL/5/GEN M,2

This Page Intentionally Blank

B10-80

OV105

OPCL/ALL/GEN M

AV BAY 3A

NOTE

While performing proc, note any cbs open.

Equipment still pwr'd in Av Bay following pwr'dn:

FPCA 3 MDM OF3 GCIL

FLCA 3 DSC OF3

Active comm sys equipment

S-BD PWR-AMP stby (alt sys)

- R1 1. cb AC CONTR AC3 (three) – cl
- 2. INV/AC BUS 3 – OFF (tb-OFF)
- INV PWR 3 – OFF (tb-OFF)
- 3. cb AC CONTR AC3 (three) – op
- 4. Perform FC3 SHUTDN, except PWRDN (Cue Card),
- then:
- L1 5. AV BAY 3 FAN A,B (two) – OFF
- 6. CAB FAN B – ON
- A – OFF
- L4:F 7. cb AC1 H2O LOOP PUMP 1A/2 (three) – cl
- L1 H2O PUMP LOOP 1 – ON
- 2 – GPC

If Triple G2:

- CRT 8. CONFIG – ITEM 1 +2 EXEC
- Modify MC 2 per table -- -->
- 9. GNC, OPS 201 PRO
- O6 10. √GPC MODE 3 – HALT
- √OUTPUT 3 – NORM
- √PWR 3 – OFF
- 11. MDM FF3 – OFF
- 12. Perform PL PWRDN, then:
- O7 13. √GPS 3 PWR – OFF
- √PRE AMPL – OFF
- O13:A 14. cb ESS 1BC C/W A – op
- :C 2CA C/W B – op
- (all SM tones and C/W lights and
- tones lost; CRT FAULT SUMM
- and SM ALERT light remains)
- O13:E 15. cb ESS 3AB AC3 SNSR – op
- 16. Perform LOSS OF VERNIERS
- (ORB OPS, RCS) while continuing
- with pwr'dn, then:

CONFIG	2
GPC	12000
STR 1	1
2	2
3	1
4	2
PL 1/2	0
CRT 1	1
2	2
3	0
4	1
L 1	0
2	0
MM 1	1
2	2

Cont next page

B10-81

OV105

OPCL/5/GEN M,10

- If comm not working:
- A1L 17. √S-BD PM MODE sel – TDRS DATA
 √NSP DATA RATE XMIT – HI
 √RCV – HI
 √CODING XMIT – ON
 √RCV – ON
 √PWR – 1
 √UPLK DATA – S-BD
- C3 18. S-BD PM CNTL – PNL,CMD
- If comm still not working:
19. S-BD PL CNTL – PNL
 PWR SYS – OFF
- A1L 20. PL DATA INTLVR PWR – OFF
- C3 21. S-BD PM CNTL – PNL
 ANT SW ELEC – OFF
 PRE AMP – OFF
 PWR AMPL STBY – OFF
 OPER – OFF
- A1L 22. NSP PWR – OFF
 ENCRYPTION PWR – OFF
- MA73C:A 23. MCA LOGIC MNC FWD 3 – OFF

NOTE

If comm presently working, performing a PNL,CMD may result in loss of comm (if fire has aff alt comm sys)

- L4:H 24. cb AC1 AV BAY 3 FAN B (three) – op
25. Perform MAL, EPS SSR-130, BUS LOSS: AC3, except:
 L1 √AV BAY 3 FAN A,B (two) – OFF, then:
- For deorb prep:
 If orbit 3 deorbit:
26. Go to LAUNCH DAY DEORBIT PREP
 (ORBIT 3) (CONT DEORB, LAUNCH DAY
ORBIT 3) >>
27. Perform MAL, ECLS SSR-12, AV BAY FIRE
 RECOVERY/RECONFIG, Checkout and Recovery,
 then:
- For deorb prep:
 If orbit 7 deorbit:
28. Perform Deltas to nominal POST INSERTION,
 DEORB PREP (POST INSERT, ORBIT 7 D/O),
 then:
29. Go to AV BAY FIRE (DEORB PREP,
CONTINGENCY DELTAS)

OV105

PRIORITY PWRDN PROCEDURES

(And Mission Specific Pwrdns)

1. Letter coded priority pwrdns are for mission specific operations. Group A (normal) is standard sw list config for on-orbit operations. Group B (LOW LEVEL) and Group C (MSN EXT) are specialized pwrdns. Group B (with A) comprises a nonstandard avionics config to be used nominally on power-critical missions not normally involving payload deploys, rendezvous, proximity, or RMS operations. Group C (with A) will be implemented, if reqd, during mission extension days.

Activities not consistent with Group B and C Pwrdns are:

LOW LEVEL CONFIG (Group B)

- a. OMS BURNS
- b. FCS CHECKOUT
- c. NOMINAL OPS TRANSITIONS (i.e., not reqd for troubleshooting)
- d. DEORB PREP
- e. DTOs

MISSION EXT (Group C)

- f. OMS BURNS
- g. FCS CHECKOUT
- h. OPS TRANSITIONS
- i. CIRC PUMP OPS
- j. APU OPS
- k. PLBD OPS
- l. KU BAND OPS
- m. PAYLOAD OPS
- n. DEORB PREP
- o. DTOs

**PRIOR
PWRDN**

Pwrup for any of the activities listed above will be accomplished using the B or C Pwrdns in reverse order.

2. Numbered priority pwrdn procs are for contingency use, and are listed according to operational criticality, higher numbers resulting in greater power reduction. Usage of any numbered pwrdn assumes sequential inclusion of all lower numbered procs.

OV103,104

A11-1

OPCL/ALL/GEN M

3. The loads for the major power users are presented below.
4. Use PWRUP column in reverse order to back out of numbered priority pwrdns.

**PRIOR
PWRDN**

<u>Equipment</u>	<u>dc Watts</u> (Avg)	<u>Pnl</u>
MADS – ASCENT/ENTRY	305	C3
– ORBIT	128	
LTG PNL (L OVHD, L CTR)	654	O6
LTG PNL (R OVHD, R)	396	O8
LTG INST (L/CTR, OVHD)	108	O6
LTG INST (R)	63	O8
GPC (RUN)	560	O6
GPC (HALT)	56	O6
IDP	55	C2
MDU	66	R14:A
ADC	3.7	R14:A
FLT CNTLR PWR	10	F7,F8
ADI/DDU	129	O14,O15, O16:E
TACAN – SEARCH	75	O7
– TRACK	50	
MLS	55	O14,O15, O16:E
GPS	25.2	A13
RA	23	O8
HUD	245	F3
IMU – OPER	119	O14,O15, O16:A
– STBY	55	
FREON LOOP PUMP	467	L1
H2O PUMP LOOP	258	L1
FES HTRS – (FES OFF)	222	L1
– (FES ON)	600	
ACIP htr	50	A7U

OV103,104

PRIORITY PWRDN GROUP A

PNL	GRP A PWRDN (normal)	PWRUP
O14, O15, O16:A :E C3 O14, O15, O16:F O17:A :B :D O7 O8 L1 L2 F6,F8 A12 O6	<p>Nominal on-orbit config:</p> <ol style="list-style-type: none"> 1. Lights – OFF except when needed 2. BRAKES (three) – OFF 3. cb ADTA (four) – op <p>If ASA – ON:</p> <ol style="list-style-type: none"> 4. Sequence FCS CH (four) – OFF rapidly, then: 5. ASA (four) – OFF 6. ATVC (four) – OFF 7. EIU (three) – OFF 8. MEC (two) – OFF 9. TACAN MODE sel (three) – OFF 10. RDR ALTM (two) – OFF 11. MLS (three) – OFF 12. HI LOAD DUCT HTR sel – OFF 13. ANTISKID – OFF 14. FLT CNTLR PWR (two) – OFF 15. APU HTR TK/FU LN/H2O SYS: One set – AUTO, one set – OFF 16. GPC MODE 3 – STBY (tb-bp) – HALT (tb-bp) – STBY (tb-RUN) – HALT (tb-bp) 5 – STBY (tb-RUN) – HALT (tb-bp) 	①
Cont next page		

① As reqd per other FDF documents

OV103,104

A11-3

OPCL/3,4/GEN M

PNL	GRP A	PWRDN (Cont)	(normal)	PWRUP
O6	17.	GPC MODE 2 – as reqd	②	③
O14, O15, O16:A	18.	RGA (four) – OFF		
O14, O15:E	19.	cb ACCEL 1,2 (two) – op		
O15, O16:F	20.	ACCEL 4,3 (two) – OFF		
F3	21.	HUD PWR (two) – OFF		
O14, O15, O16:E	22.	cb DDU L,R,AFT (six) – op		⑤
	23.	IDPs – three ON for crew awake MDUs – ON as desired All MDUs and IDPs OFF for crew single-shift sleep		④
O6	24.	UHF MODE sel – OFF		SPLX

② If GPC 2 not reqd, perform G2 SET CONTRACTION (ORB OPS, DPS)

③ As reqd per FLIGHT PLAN, perform G2 SET EXPANSION (ORB OPS, DPS)

④ Other(s) ON as reqd

⑤ ON as reqd for FLT CNTLR PWR

OV103,104

A11-4

OPCL/ALL/GEN M

PRIORITY PWRDN PROCEDURES

(And Mission Specific Pwrdns)

1. Letter coded priority pwrdns are for mission specific operations. Group A (normal) is standard sw list config for on-orbit operations. Group B (LOW LEVEL) and Group C (MSN EXT) are specialized pwrdns. Group B (with A) comprises a nonstandard avionics config to be used nominally on power-critical missions not normally involving payload deploys, rendezvous, proximity, or RMS operations. Group C (with A) will be implemented, if reqd, during mission extension days.

Activities not consistent with Group B and C Pwrdns are:

LOW LEVEL CONFIG (Group B)

- a. OMS BURNS
- b. FCS CHECKOUT
- c. NOMINAL OPS TRANSITIONS (i.e., not reqd for troubleshooting)
- d. DEORB PREP
- e. DTOs

MISSION EXT (Group C)

- f. OMS BURNS
- g. FCS CHECKOUT
- h. OPS TRANSITIONS
- i. CIRC PUMP OPS
- j. APU OPS
- k. PLBD OPS
- l. KU BAND OPS
- m. PAYLOAD OPS
- n. DEORB PREP
- o. DTOs

PRIOR
PWRDN

Pwrup for any of the activities listed above will be accomplished using the B or C Pwrdns in reverse order.

2. Numbered priority pwrdn procs are for contingency use, and are listed according to operational criticality, higher numbers resulting in greater power reduction. Usage of any numbered pwrdn assumes sequential inclusion of all lower numbered procs.

OV105

B11-1

OPCL/ALL/GEN M

3. The loads for the major power users are presented below.
4. Use PWRUP column in reverse order to back out of numbered priority pwrdns.

**PRIOR
PWRDN**

<u>Equipment</u>	<u>dc Watts</u> (Avg)	<u>Pnl</u>
MADS – ASCENT/ENTRY	305	C3
– ORBIT	128	
LTG PNL (L OVHD, L CTR)	654	O6
LTG PNL (R OVHD, R)	396	O8
LTG INST (L/CTR, OVHD)	108	O6
LTG INST (R)	63	O8
GPC (RUN)	560	O6
GPC (HALT)	56	O6
IDP	55	C2
MDU	66	R14:A
ADC	3.7	R14:A
FLT CNTLR PWR	10	F7,F8
ADI/DDU	129	O14,O15, O16:E
MLS	55	O14,O15, O16:E
GPS	25.2	O7
RA	23	O8
HUD	245	F3
IMU – OPER	119	O14,O15, O16:A
– STBY	55	
FREON LOOP PUMP	467	L1
H2O PUMP LOOP	258	L1
FES HTRS – (FES OFF)	222	L1
– (FES ON)	600	
ACIP htr	50	A7U

OV105

OPCL/5/GEN M

PRIORITY PWRDN GROUP A

PNL	GRP A	PWRDN (normal)	PWRUP
		Nominal on-orbit config:	①
O14, O15, O16:A :E		1. Lights – OFF except when needed 2. BRAKES (three) – OFF	
C3		3. cb ADTA (four) – op If ASA – ON: 4. Sequence FCS CH (four) – OFF rapidly, then:	
O14, O15, O16:F O17:A :B :D		5. ASA (four) – OFF 6. ATVC (four) – OFF 7. EIU (three) – OFF 8. MEC (two) – OFF	
O7		9. GPS 1,3 PWR (two) – OFF PRE AMPL (four) – OFF	
O8		10. RDR ALTM (two) – OFF 11. MLS (three) – OFF	
L1 L2		12. HI LOAD DUCT HTR sel – OFF 13. ANTISKID – OFF	
F6,F8 A12		14. FLT CNTLR PWR (two) – OFF 15. APU HTR TK/FU LN/H2O SYS: One set – AUTO, one set – OFF	
O6		16. GPC MODE 3 – STBY (tb-bp) – HALT (tb-bp) – STBY (tb-RUN) – HALT (tb-bp) 5 – STBY (tb-RUN) – HALT (tb-bp)	
Cont next page			

① As reqd per other FDF documents

OV105

OPCL/5/GEN M

B11-3

PNL	GRP A	PWRDN (Cont)	(normal)	PWRUP
O6	17.	GPC MODE 2 – as reqd	②	③
O14, O15, O16:A	18.	RGA (four) – OFF		
O14, O15:E	19.	cb ACCEL 1,2 (two) – op		
O15, O16:F	20.	ACCEL 4,3 (two) – OFF		
F3	21.	HUD PWR (two) – OFF		
O14, O15, O16:E	22.	cb DDU L,R,AFT (six) – op		⑤
	23.	IDPs – three ON for crew awake MDUs – ON as desired All MDUs and IDPs OFF for crew single-shift sleep		④
O6	24.	UHF MODE sel – OFF		SPLX

② If GPC 2 not reqd, perform G2 SET CONTRACTION (ORB OPS, DPS)

③ As reqd per FLIGHT PLAN, perform G2 SET EXPANSION (ORB OPS, DPS)

④ Other(s) ON as reqd

⑤ ON as reqd for FLT CNTLR PWR

OV105

B11-4

OPCL/ALL/GEN M

PRIORITY PWRDN GROUP B

PNL	GRP B	PWRDN (LOW LEVEL)	PWRUP
		NOTE KU-BD and S-BD FM sw: As reqd to conserve energy and accomplish mission objectives, MCC will cmd	
		1. Turn off all lights except Middeck lts 6,7,8 (no lts for single-shift sleep, one for split-shift sleep)	As reqd
C3		2. MSTR MADS PWR – OFF (as reqd, cycle ON per FLIGHT PLAN)	ON
A14		3. RCS/OMS HTR L POD (two) – A AUTO, B OFF R POD (two) – A AUTO, B OFF	MCC call
GALLEY		4. H2O HTR (two), OVEN FAN – OFF ①	ON ①
O14, O15, O16:E		5. cb DDU L,R,AFT (six) – op	cl
		If GPC MODE 2 – RUN:	
		6. Perform G2 SET CONTRACTION (ORB OPS, <u>DPS</u>), then:	②
O15:F		7. MMU 2 – OFF (1 of 2 off)	ON
		8. Minimize PGSC use	
O14, O15, O16:F		9. Pri RJDF DRIVER, LOGIC (eight) – OFF	ON
		10. Pri RJDA DRIVER, LOGIC (eight) – OFF RJDA 1A L2/R2 DRIVER – ON	ON
		11. Use only one IDP with three MDUs max. All IDPs and MDUs OFF for single-shift sleep; otherwise – ON	ON
		12. GNC 21 IMU ALIGN	③
		IMU 2 STBY – ITEM 22 EXEC	
		13. COLOR PRINTER – OFF	④

① Insert drink package to keep water tank pump from cycling (water temp may decrease slightly); if repowering Galley, remove drink package

② If reqd, go to G2 SET EXPANSION (ORB OPS, DPS)

③ Recover IMU 2 (MAL, GNC FRP-3)

④ MCC will instruct crew when to turn COLOR PRINTER ON

PRIORITY PWRDN GROUP C

PNL	GRP C	PWRDN (MSN EXT)	PWRUP
		1. Perform PRIORITY PWRDN GROUP 1,2 If prior to first deorbit prep:	
		2. Perform PRIORITY PWRDN GROUP 3A, then:	
		3. Turn off all lights except two Middeck lts (use no lts for single-shift sleep or split-shift sleep)	
GALLEY		4. H2O HTR (two), OVEN FAN – OFF ①	ON ①
		5. MDUs: Cycle ON when reqd	
O14,		6. Pri RJDF DRIVER, LOGIC (eight) – OFF	ON
O15,		7. Pri RJDA DRIVER, LOGIC (eight) – OFF	ON
O16:F		RJDA 1A L2/R2 DRIVER – ON	
O6		8. MDM PL2 – OFF ②	ON ③
A14		9. RCS/OMS HTR L POD (two) – A AUTO, B OFF R POD (two) – A AUTO, B OFF	MCC call
A1L		10. PL DATA INTLVR PWR – OFF S-BD PL PWR SYS – OFF CNTL – PNL, CMD ④	MCC call MCC call
A1R		11. FM PWR – OFF CNTL – PNL, CMD	1 ⑤
O6		12. √UHF MODE sel – OFF	
		13. KU-BAND SYS – max 2 hr ON/day ⑤	
O14,		14. cb DDU L,R,AFT (six) – op	cl
O15,			
O16:E			
		15. COLOR PRINTER – OFF	MCC call

- ① Insert drink package to keep water tank pump from cycling (water temp may decrease slightly); if repowering Galley, remove drink package
- ② Before powering off PF2 MDM, √MCC for Antenna Electronics 1 activation
- ③ SM I/O RESET
- ④ If PDI and/or PSP pwrd off, expect 'S62 BCE BYP PL', 'S62 BCE BYP PDI' and/or 'S62 BCE BYP PSP' msgs
- ⑤ As reqd, MCC will command

PRIORITY PWRDN GROUP 1

PNL	GRP 1 PWRDN	PWRUP
O15:F	1. Minimize ltg 2. Use only one IDP with three MDUs max If GPC 2 – RUN: 3. Perform G2 SET CONTRACTION (ORB OPS, <u>DPS</u>), then: 4. MMU 2 OFF – (1 of 2 off) 5. <u>GNC 21 IMU ALIGN</u> IMU 2 STBY – ITEM 22 EXEC	① ON ②

① If reqd, go to G2 SET EXPANSION (ORB OPS, DPS)

② Recover IMU 2 (MAL, GNC FRP-3)

PRIORITY PWRDN GROUP 2

PNL	GRP 2 PWRDN	PWRUP
O6	1. S TRK PWR -Y,-Z (two) – OFF 2. Perform GPS PWRDN (ORB OPS, <u>GNC</u>) for GPS 2 3. MDM FF2,4 (two) – OFF FA4 – OFF	As reqd ① ON ②
C3 L1	4. MSTR MADS PWR – OFF 5. FLASH EVAP CNTLR PRI (two) – OFF SEC – OFF TOP EVAP HTR NOZ (two) – OFF DUCT sel – OFF	ON ③ ④ Two ON ③ ON
MA73C:F A8L	6. cb AC1 RMS PRI Φ A – op 7. PORT RMS HTR A(B) – OFF * If PDRS PORT TEMP msg (MA tone only): * * Within 30 min, PORT RMS HTR A(B) – * * AUTO * * On MCC call: * * PORT RMS HTR A(B) – OFF; * * repeat as reqd *	
OCAC	8. Use only one orbiter PGSC If OCAC flown: 9. OCAC PWR – OFF	ON

① Perform GPS PWRUP (ORB OPS, GNC) for GPS 2

② GNC I/O RESET

③ Perform TOPPING FES STARTUP, using Pri A/B (ORB OPS, ECLS)

④ SEC CNTLR ON only if both primary controllers failed

PRIORITY PWRDN GROUP 3

Perform PL PWRDN

PRIORITY PWRDN 3A (PP3A) contains recoverable PL ops pwrdn steps. PRIORITY PWRDN 3B (PP3B) is a total PL pwrdn that may cause PL ops to be nonrecoverable

PRIORITY PWRDN GROUP 4

PNL	GRP 4 PWRDN	PWRUP
GALLEY	1. H2O HTR (two), OVEN FAN – OFF If RMS pwrn: 2. Perform <u>RMS PWRDN</u> (PDRS OPS), then:	ON MCC call
L4:L	3. cb AC1 ΦB AV BAY 2 S/C – op	cl

PRIORITY PWRDN GROUP 5

PNL	GRP 5 PWRDN	PWRUP
O15:A	1. IMU 2 – OFF (1 of 3)	①
	2. <u>GNC 20 DAP CONFIG</u> TAIL P,Y OPTION DAP: X/AUTO/PRI	②
O8	3. FWD RCS MANF ISOL 1,2,3,4 (four) – CL	③
O6	4. MDM PL2 – OFF	ON ④
A14	5. RCS/OMS HTR FWD RCS JET 1,2,3,4 (four) – OFF	AUTO ON
O14, O15, O16:F	6. RJDF DRIVER,LOGIC (eight) – OFF	
O14:C	7. cb UTIL PWR O19/MO52J – op	cl
O15:C	F1/MO13Q – op	cl
	8. Perform <u>KU-BD ANT STOW</u> (ORB OPS, <u>COMM/INST</u>), then:	⑤
R14:C	9. cb MNB KU ANT HTR – op	cl

- ① Recover IMU 2 (MAL, GNC FRP-3)
- ② At MCC call, sel JET OPT 1 (cont PWRUP until AOS)
- ③ For PWRUP, perform MAL, RCS SSR-4, STAGED, MANF REPRESS
- ④ SM I/O RESET
- ⑤ Perform KU-BD ANT DEPLOY (ORB OPS, COMM/INST)

PRIORITY PWRDN GROUP 6

PNL	GRP 6	PWRDN	PWRUP
O14:A	1.	IMU 1 – OFF (2 of 3 off)	①
O15:D	2.	cb O2/N2 CNTLR 2 – op	cl
O16:E	3.	RCS/OMS PRPLT QTY GAUGE – op	cl
L4:L	4.	AC1 ΦA CAB T CNTLR 2 – op AC2 ΦA CAB T CNTLR 1 – op (if desired, pin CAB T CNTLRS)	cl cl
R2	5.	BLR CNTLR/HTR (three) – OFF	B
A12	6.	APU HTR LUBE OIL LN (three) – OFF HYD HTR A (four) – OFF B (four) – OFF	B AUTO √OFF AUTO
A14	7.	RCS/OMS HTR OMS CRSFD LN (two) – A OFF, B OFF	ON
ML31C	8.	VAC VENT NOZ HTR – OFF	As reqd
ML86B:C	9.	cb MNB EXT AIRLK HTR STRUCT Z1/2/3 – op VEST Z1/2/3 – op	cl cl
:A	10.	cb MNA H2O LN HTR A – op MNB H2O LN HTR B – op	cl ② cl ②
ML86B:D	11.	If MMU pwrn: cb MNA MMU PORT HTR A – op STBD HTR A – op MNB MMU PORT HTR B – op STBD HTR B – op	
MA73C	12.	MCA LOGIC MNA,B,C: MID 1,2,3,4 (eight) – OFF	ON
A6U	13.	ANNUN BUS SEL – OFF	MNC
R14:D	14.	cb MNA TV C AFT BAY CAMR HTR – op PAN-TILT HTR – op MNB TV A FWD BAY CAMR HTR – op PAN-TILT HTR – op MNC B TV B KEEL/EVA CAMR HTR – op PAN-TILT HTR – op	cl cl cl cl cl cl
:E	15.	cb MNB RMS PORT RMS TV CAMR HTR – op PAN-TILT HTR – op MNA D STBD RMS TV CAMR HTR – op PAN-TILT HTR – op	cl cl cl cl
	16.	Purge both supply,waste H2O lines. Go to SUPPLY(WASTE) H2O PURGE FROM DUMP LINE(S) (IFM, <u>PROCEDURES S THRU Z</u>)	③

- ① Recover IMU 1 (MAL, GNC FRP-3)
- ② One of two reqd
- ③ For PWRUP, reopen SPLY(WASTE) H2O DUMP ISOL VLV

PRIORITY PWRDN GROUP 7

PNL	GRP 7	PWRDN	PWRUP
O13:D	1.	cb CRYO (four) – op	cl
O14:C	2.	cb MNA CRYO O2 HTR TK1 SNSR 1 – op	cl
:F	3.	MMU 1 – OFF (2 of 2 off)	ON
O16:C	4.	cb MNC CRYO O2 HTR TK1 SNSR 2 – op	cl
L4:K	5.	cb AC1 ΦA H2O CNTLR 2 – op	cl
L1	6.	FREON PUMP LOOP 2 – OFF	ON
		RAD CNTLR LOOP 2 – OFF	A
L2		O2 SYS 2 SPLY – CL (tb-CL)	OP (tb-OP)
R1	7.	O2 TK1,TK2,TK3 HTRS A (three) – OFF	AUTO
		TK1,TK3 HTRS B (two) – OFF	AUTO
		H2 TK1,TK2,TK3 HTRS A (three) – OFF	AUTO
		TK1,TK3 HTRS B (two) – OFF	AUTO
		If Primary Jets Only Option:	
	8.	Go to step 17	
		If Vernier Jets Only Option:	
	9.	Go to step 27	
		If Gravity Gradient Option:	①
	10.	Perform GG FREE DRIFT, ATT ID B, steps 1,2 (do not sel LO Z) (ORB OPS, RCS), then:	
O14, O15, O16:F	11.	All RJD DRIVER,LOGIC (seventeen) – OFF	②
	12.	Perform RCS SECURE (FWD,AFT) (RCS), 8-2, then:	
O6	13.	MDM FF1 – OFF	ON
		FA1,FA2,FA3 (three) – OFF	ON
MA73C	14.	MCA LOGIC MNA,B,C:	
		FWD 1,2,3 (three) – OFF	ON
		AFT 1,2,3 (three) – OFF	ON
A14	15.	RCS/OMS HTR FWD RCS – OFF	AUTO
		RCS JET (five) – OFF	AUTO
		AFT RCS JET (five) – OFF	AUTO
	16.	Go to step 31	

Cont next page

- ① Perform GG FREE DRIFT, step 3 (ORB OPS, RCS)
- ② Perform MAL, RCS SSR-4, STAGED, MANF REPRESS (FRCS only). √L,R MANF P > 130 prior to MANF ISOL – OP

PNL	GRP 7 PWRDN (Cont)	PWRUP
	17. Perform XFEED: L RCS to R RCS (RCS), 8-5, then:	
O6	18. GNC 23 RCS Ovrd L,R,1,3,4,5 STAT – CL	OP
	19. MDM FA2 – OFF FF1 – OFF	ON (3)
	20. GNC 20 DAP CONFIG √TAIL P,Y OPTION	
O14:F	21. RJDA 1A L2/R2 LOGIC – ON DRIVER – ON	
O14, O15, O16:F	22. (Remaining) RJD DRIVER,LOGIC (fifteen) – OFF	ON
O7	23. AFT L,R RCS MANF ISOL 5 (two) – CL	OP
O8	24. FWD RCS MANF ISOL 5 – CL	CL
A14	25. RCS/OMS HTR FWD RCS – OFF RCS JET (five) – OFF AFT RCS JET 1,3,4,5 (four) – OFF	AUTO AUTO AUTO
	26. Go to step 31	
O6	27. MDM FA3 – OFF FF1 – OFF	
O16:F	28. √Vern RJD – ON	
O14, O15, O16:F	29. Pri RJD DRIVER,LOGIC (sixteen) – OFF	ON
A14	30. RCS/OMS HTR FWD RCS – OFF RCS JET 1,2,3,4 (four) – OFF AFT RCS JET 1,2,3,4 (four) – OFF	AUTO AUTO AUTO
A11	31. CRYO TK HTR (four) – OFF	AUTO MCC call
Cont next page		

(3) GNC I/O RESET

PNL	GRP 7	PWRDN (Cont)	PWRUP
ML86B:C	32.	cb EXT AIRLK HTR LN ZONE 1 (three) – op 2 (three) – op	cl cl
	:F	33. cb CRYO O2 HTR SNSR (four) – op	cl
	:G	34. All cbs – op	MCC call
R1		If three good FCs, shut dn FC2 and AC2 per the following:	④
	35.	MN BUS TIE A,B (two) – ON (tb-ON)	
	36.	Perform AC2 BUS LOSS ACTION (EPS), 5-30, <u>only</u> , leaving FC2 REACS open, then:	
	37.	cb AC CONTR (three) – cl INV/AC BUS 2 – OFF (tb-OFF)	op ON (tb-ON)
		INV PWR 2 – OFF (tb-OFF)	ON (tb-ON)
		AC BUS SNSR 2 – OFF	ON
	38.	Use only IDP4, aft MDUs, and aft FLT CNTLR PWR	As reqd

④ Perform MAL, EPS SSR-6, FC RESTART, then:
MN BUS TIE A,B (two) – OFF (tb-OFF)



CUE CARD CONFIGURATION

**CUE
CARDS**

12-1

OPCL/ALL/GEN M



TOP

<p>TARGET DATA</p> <p>OMS L 2</p> <p>R 3</p> <p>5 TV ROLL</p> <p>TRIM LOAD</p> <p>6 P</p> <p>7 LY</p> <p>8 RY</p> <p>9 WT</p> <p>10 TIG</p> <p>* Current MET + 10 min</p> <p>TGT PEG 7</p> <table border="1" style="display: inline-table; margin-right: 10px;"> <tr><th colspan="4">OUT-OF-PLANE</th></tr> <tr><td>19 ΔVX</td><td>()</td><td></td><td>0 . 0</td></tr> <tr><td>20 ΔVY</td><td>()</td><td>5 0 0</td><td>0 . 0</td></tr> <tr><td>21 ΔVZ</td><td>()</td><td></td><td>0 . 0</td></tr> </table> <table border="1" style="display: inline-table;"> <tr><th colspan="4">RETROGRADE</th></tr> <tr><td>(-)</td><td></td><td></td><td>0 . 0</td></tr> <tr><td>()</td><td></td><td></td><td>0 . 0</td></tr> <tr><td>()</td><td></td><td></td><td>0 . 0</td></tr> </table>	OUT-OF-PLANE				19 ΔVX	()		0 . 0	20 ΔVY	()	5 0 0	0 . 0	21 ΔVZ	()		0 . 0	RETROGRADE				(-)			0 . 0	()			0 . 0	()			0 . 0	<p>LEAKING OMS PRPLT/ He BURN</p>	<p>BURN DATA</p> <p>BURN ATT</p> <table border="1" style="display: inline-table; margin-right: 10px;"> <tr><td>24 R</td><td></td><td></td></tr> <tr><td>25 P</td><td></td><td></td></tr> <tr><td>26 Y</td><td></td><td></td></tr> </table> <p>ΔVTOT</p> <table border="1" style="display: inline-table; margin-right: 10px;"> <tr><td></td><td></td><td></td><td>.</td><td></td></tr> </table> <p>TGO</p> <table border="1" style="display: inline-table; margin-right: 10px;"> <tr><td>:</td><td></td><td></td><td></td><td></td></tr> </table> <p>VGO X</p> <table border="1" style="display: inline-table; margin-right: 10px;"> <tr><td>()</td><td></td><td></td><td>.</td><td></td></tr> </table> <p>Y ()</p> <table border="1" style="display: inline-table; margin-right: 10px;"> <tr><td></td><td></td><td>.</td><td></td><td></td></tr> </table> <p>Z ()</p> <table border="1" style="display: inline-table; margin-right: 10px;"> <tr><td></td><td></td><td>.</td><td></td><td></td></tr> </table> <p>TGT</p> <table border="1" style="display: inline-table; margin-right: 10px;"> <tr><td>HA</td><td></td><td></td></tr> </table> <table border="1" style="display: inline-table;"> <tr><td>HP</td><td>()</td><td></td></tr> </table>	24 R			25 P			26 Y						.		:					()			.				.					.			HA			HP	()	
OUT-OF-PLANE																																																																										
19 ΔVX	()		0 . 0																																																																							
20 ΔVY	()	5 0 0	0 . 0																																																																							
21 ΔVZ	()		0 . 0																																																																							
RETROGRADE																																																																										
(-)			0 . 0																																																																							
()			0 . 0																																																																							
()			0 . 0																																																																							
24 R																																																																										
25 P																																																																										
26 Y																																																																										
			.																																																																							
:																																																																										
()			.																																																																							
		.																																																																								
		.																																																																								
HA																																																																										
HP	()																																																																									

√MM202** √CNTLR PWR (two) – ON √ATT
 (302)** √ADI – REF/HP √DAP – AUTO**
 √ENG SEL (LVLH/HP) (AUTO/DISC)**

If retrograde burn: √TGT HP = 95±1; adjust ΔVX as reqd
 Enter TGO + 10 sec
 TIG-2 Selected OMS ENG – ARM/PRESS

WARNING

Do not burn if: OMS He TK P < 640
 FU ENG IN P < 216
 OX ENG IN P < 151
 Payload/RMS not berthed or stowed

-:15 EXEC, and if PRPLT LEAK, THC + X
 :00 TIG** (√Pc, ΔVTOT, ENG VLV)
 +:01 Release THC
 If PRPLT LEAK, when CUR HP = 95±1 or Pc < 80:
 OMS ENG – OFF; secure aff OMS
 If He LEAK, when CUR HP = 95±1 or OMS He TK
 P < 640 or OMS QTY < 39 OMS ENG – OFF
 If reqd, repeat proc to burn OUT-OF-PLANE; start
 in step 6 (if ENT PKT, start in step 5)

* On MCC call: *
 * If PER ADJ TIG < four orbits from Deorb TIG, FRCS *
 * QTY > 6%, and ΔVTOT > 10 fps at OMS fail, mnvr to *
 * -X ATT (pitch up at 3°/sec to VGOz = 1/4 ΔVTOT): *
 * THC -X to CUR HP = 95 or FRCS PRPLT deplete *
 CUTOFF**
 +:02 OMS ENG – OFF** (if < three IMU, at []:[])

OPCL-1a/O/G

(reduced copy)

FAB USE ONLY

CC 12-2

OPCL/ALL/GEN M

CUE CARDS

TOP
BACK OF 'LEAKING OMS PRPLT/He BURN'



**HOOK
VELCRO**

**HOOK
VELCRO**



FAB USE ONLY

(reduced copy)
CC 12-3

OPCL-1b/O/B

OPCL/ALL/GEN M



TOP

HOOK
VELCRO

HAZARDOUS SPILL RESPONSE – ORBITER

LEVEL 4 (RED) MOST HAZARDOUS SPILL (NONCONTAINABLE)

1. Inform other crew, MCC – “Level 4 spill in cabin”
2. All crew don/activate QDMs
3. QDM Regulator mode – EMERGENCY (red knob cw)

If Booster Fan active:

MO13Q 4. AIRLK FAN A(B) – OFF, then:

If hatches to ISS open:

5. Simo, perform JOINT EMERGENCY EGRESS (Cue Card), continue with this proc

L1 6. CAB TEMP sel – COOL

WCS 7. MODE – COMMODE/MANUAL/EMU

8. COMMODE CNTL – PULL UP (wait 15 sec), PUSH FWD

OCAC 9. √OCAC PWR – ON

10. √MCC

R
E
D

LEVEL 3 (ORANGE) HAZARDOUS SPILL (CONTAINABLE)

1. Inform other crew, MCC – “Level 3 spill in cabin”
2. All crew don/activate QDMs
3. QDM Regulator mode – EMERGENCY (red knob cw)

If Booster Fan active:

MO13Q 4. AIRLK FAN A(B) – OFF, then:

If hatches to ISS open:

5. Simo, perform JOINT EMERGENCY EGRESS (Cue Card), continue with this proc

L1 6. CAB FAN A(B) – OFF (max 30 min)

7. IMU FAN B(A,C) – OFF (max 90 min)

OCAC 8. OCAC PWR – OFF

CCK 9. Cleanup crew don Silver Shield Gloves, clean up spill w/Dry Wipes. Bag, label, stow in Wet Trash

If cleanup fails, perform steps 13 and 14, then go to Level 4 step 6 >>

10. QDM Regulator mode – NORM (red knob ccw)
11. Doff Quick Don Masks, gloves. Stow gloves in Wet Trash
12. Inform other crew, MCC – “Spill in cabin cleaned up”

L1 13. CAB FAN A(B) – ON

14. IMU FAN B(A,C) – ON

OCAC 15. OCAC PWR – ON

If Booster Fan in bypass config >>

MO13Q 16. AIRLK FAN A(B) – ON

O
R
A
N
G
E

HOOK
VELCRO

OPCL-2a/O/L

(reduced copy)

FAB USE ONLY

CC 12-4

OPCL/ALL/GEN M

TOP
BACK OF 'HAZARDOUS SPILL RESPONSE – ORBITER'

HOOK
VELCRO

HAZARDOUS SPILL RESPONSE – ORBITER

	LEVEL 2 (YELLOW) HAZARDOUS SPILL
	LEVEL 1 (BLUE) LEAST HAZARDOUS SPILL
	LEVEL 0 (GREEN) NONHAZARDOUS SPILL
	1. Inform other crew, MCC – “Level 2(1,0) spill in cabin”
	If Level 2 spill:
CCK	2. Cleanup crew in vicinity don goggles, masks, and gloves (√MCC for Silver Shield or latex)
	If Level 1 spill:
CCK	3. Cleanup crew in vicinity don goggles, masks, latex gloves
	If Level 0 controlled spill, >>
	If Booster Fan active:
MO13Q	4. AIRLK FAN A(B) – OFF, then:
L1	5. CAB FAN A(B) – OFF (max 30 min)
	6. IMU FAN B(A,C) – OFF (max 90 min)
OCAC	7. OCAC PWR – OFF
CCK	8. Clean up spill w/Dry Wipes. Bag, label, stow in Wet Trash
	If Level 2(1,0) cleanup fails, perform steps 11 and 12, then go to Level 4 step 5 >>
	9. As reqd, doff goggles, masks, gloves. Stow gloves in Wet Trash
	10. Inform other crew, MCC – “Spill in cabin cleaned up”
L1	11. CAB FAN A(B) – ON
	12. IMU FAN B(A,C) – ON
OCAC	13. OCAC PWR – ON
	If Booster Fan in bypass config >>
MO13Q	14. AIRLK FAN A(B) – ON

Y
E
L
L
O
W

HOOK
VELCRO

OPCL-2b/O/J

(reduced copy)

FAB USE ONLY

CC 12-5

OPCL/ALL/GEN M

TOP
BACK OF 'FIRE/SMOKE'

V
E
L
C
R
O
H
O
O
K

FIRE/SMOKE
(ASCENT/ENTRY)
(AESP-7a), front of
FIRE/SMOKE (ORBIT)
appears in the
ASCENT/ENTRY SYSTEMS
PROCEDURES

FIRE/SMOKE (ORBIT)
SM SYS SUMM 1

- If **VISUAL SMOKE/FIRE**, or
two SMOKE DETN lt on, or
two CONC > 2, or
one SMOKE DETN lt on and
other CONC > 2:
- Go to step 6
- If single Av Bay SMOKE DETN A(B) lt and
assoc CONC > 2:
- SMOKE DETN CKT TEST – B(A) (25 sec)
- If SMOKE DETN B(A) test good (lt on):
- SMOKE DETN CKT TEST – OFF
 - SMOKE DETN SNSR – RESET >>
- If SMOKE DETN B(A) test bad (no lt):
- Go to step 6
- If none of above >>
- AIRLK FAN A(B) – OFF
 - If DOCKED: Perform **JOINT EMERGENCY EGRESS** (Cue Card)
Spacehab: Don SEBs, perform **SH EMERGENCY EGRESS** (Cue Card)
 - Don Quick Don Masks
LEH O2 vivs – OP
SUPPLY viv – OP
- If **AV BAY FIRE**:
- FIRE SUPPR – ARM
pb – DISCH (push until lit)
 - AV BAY FAN (two) – OFF
 - Sim, go to POST-FIRE CABIN CLEANUP (ORB PKT, ECLS) and AV BAY FIRE (ORB PKT, PWRDN)
- If **CABIN FIRE**:
- CAB FAN A,B (two) – OFF (max 20 min)
 - Locate source
 - Unpwr source of smoke
If smoke persists or source cannot be unpwr:
- WARNING**
Discharge is propulsive
- Discharge handheld FIRE EXTGHR
 - Go to POST-FIRE CABIN CLEANUP (ORB PKT, ECLS)



replace side tab with clear tape and Hook Velcro

ALARM SEQUENCE	SOURCE AREA
(L(R) FLT DK) or (L(R) FLT DK) → CABIN	PS(MS), L(R) CONSOLE
(L FLT DK) ↔ (R FLT DK)	AFT FLT DK, MIDDECK
CABIN or CABIN → (L FLT DK) → (R FLT DK)	FWD FLT DK, WCS, LEB

V
E
L
C
R
O
H
O
O
K

OPCL-7b(AESP-7b)/A,O,E/K

BOTTOM
MATE TOP-TO-BOTTOM;
FLIP VERTICALLY TO TURN

(reduced copy)

TOP

ODS VOLUME FIRE/SMOKE

ODS

MO13Q 1. AIRLK FAN A(B) – OFF
If hatches open to ISS, perform JOINT EMERGENCY EGRESS (Cue Card), then:

- A7L 2. APDS PWR (three) – OFF
- 3. √A,B,C lts (three) – OFF
- 4. HTRS/DCU PWR (three) – OFF
- 5. CNTL PNL PWR (three) – OFF
- A6L 6. PSU PWR (two) – OFF
- 7. SYS PWR MNA,MNB (two) – OFF
(hold 5 sec)
- √SYS PWR SYS1,SYS2 tb (two) – OFF

OPCL-3a/ODS/O/I

If SH HATCH flown:

- SH Hatch 8. Close SH HATCH per decal
√Equal vlvs (two) – OFF, caps installed
- Tnl Adp 9. PL ISOL vlv – CL, install cap in flex duct
- Inner Hatch 10. Close INNER HATCH per decal
√Equal vlvs (two) – OFF, caps installed
- 11. On MCC call, go to ODS POST-FIRE ACTIONS (ECLS)

TOP

BACK OF 'ODS VOLUME FIRE/SMOKE'

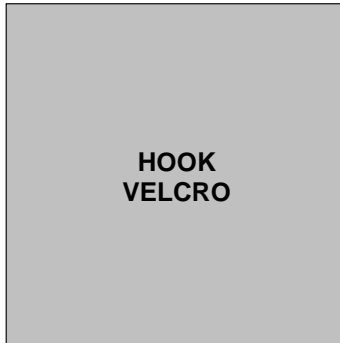

ODS

OPCL-3b/ODS/O/E

(reduced copy)

FAB USE ONLY

CC 12-7

OPCL/ODS/GEN M



This Page Intentionally Blank



Space Shuttle Program
FLIGHT DATA FILE

JSC-48033
GENERIC, REV M

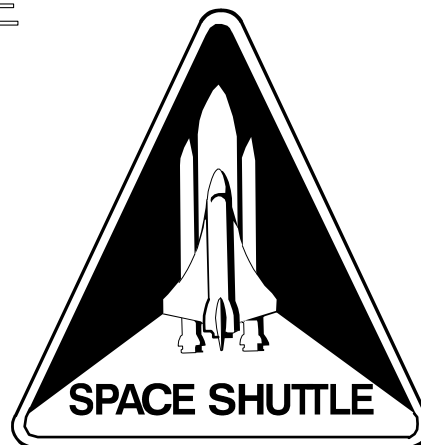

AESP:	MM101
APCL:	MM104
OPCL:	MM106
EPCL:	MM301
AESP:	MM304

ORBIT POCKET CHECKLIST

OV
ALL

Flight Cover (trim bottom to expose tabs)