

Space Program Operations Contract

Data Processing System (Hardware and System Software) Workbook

DPS HW/SW 21002

**Mission Operations Directorate
Space Flight Training and Facility Operations
DPS/Navigation Department**

November 15, 2006

Final Version

This document has been reviewed and updated.
No subsequent updates to this document are anticipated or required due to the approaching shuttle program closure.

Contract NNJ06VA01C

**Data Processing System
(Hardware and System Software)
Workbook**

DPS HW/SW 21002

Prepared by

Original approval obtained

Steven D. Hamm
Author
USA/DPS/NAV Training Department

Approved by

Original approval obtained

Walter J. Barnett
Manager
USA/DPS/NAV Training Department

REVISION LOG

Rev. letter	Change no.	Description	Date
Basic		USA number assigned; supersedes TD292; updates in all sections	08/01/03
Rev. A		USA copyright added	09/10/04
Rev. B		Technical review completed	11/15/06

TECHNICAL SUPPORT

Subject Matter Expert

Steven D. Hamm

Special Thanks To

Walter Barnett
Kelsey Berumen
Jeff Tuxhorn

LIST OF EFFECTIVE PAGES

The current status of all pages in this document is shown below.

<u>Page no.</u>	<u>Change no.</u>
Foreword	Rev B
i – viii	Rev B
1-1	Rev B
2-1 - 2-42	Rev B
3-1 - 3-97	Rev B
4-1 - 4-33	Rev B
A-1 - A-5	Rev B
B-1	Rev B

FOREWORD

This material is for training purposes only and should not be used as a source of operational data. All numerical data, displays, and checklist references are intended as examples. To determine any prerequisites before using this document, consult the applicable Certification Plan. For shuttle manuals, consult the Flight Operations Support Personnel Training Guide (Blue Book) or the Crew Training Catalog. For Space Station manuals, consult the appropriate Space Station Certification Training Guide or Training Administration Management System (TAMS). The applicable training package should be studied before attending any classroom session or lesson for which this is a prerequisite.

Direct any questions or comments to Steven Hamm, Department 4934, 281/244-7382.

CONTENTS

Section	Page
1.0 INTRODUCTION	1-1
1.1 PURPOSE OF THE DATA PROCESSING SYSTEM	1-1
1.2 DPS HARDWARE OVERVIEW.....	1-1
2.0 HARDWARE	2-1
2.1 GENERAL PURPOSE COMPUTERS.....	2-1
2.1.1 Description	2-1
2.1.2 Interfaces	2-3
2.1.3 Power, Location, and Cooling	2-7
2.1.4 Controls and Displays (Hardware)	2-7
2.2 COMPUTER DATA BUS NETWORK	2-10
2.2.1 Flight Critical Data Buses.....	2-11
2.2.2 Payload Data Buses.....	2-14
2.2.3 Launch/Boost Data Buses.....	2-15
2.2.4 Mass Memory Data Buses	2-16
2.2.5 Display/Keyboard Data Buses	2-16
2.2.6 Instrumentation/PCM Master Unit Data Buses.....	2-16
2.2.7 Intercomputer Communication Data Buses.....	2-17
2.3 MULTIPLEXER-DEMULTIPLEXER	2-19
2.3.1 Description	2-19
2.3.2 Enhanced MDMs	2-21
2.3.3 Interfaces	2-22
2.3.4 Controls and Displays	2-23
2.3.5 Power, Location, and Cooling	2-24
2.4 MODULAR MEMORY UNIT.....	2-25
2.4.1 SSMM Description	2-25
2.4.2 Interfaces	2-27
2.4.3 Controls and Displays	2-28
2.4.4 Power, Location, and Cooling	2-28
2.5 MULTIFUNCTION ELECTRONIC DISPLAY SYSTEM	2-28
2.5.1 Description	2-28
2.5.2 Power, Location, and Cooling	2-31
2.5.3 Multifunction Display Unit.....	2-32
2.5.4 Power, Location, and Cooling	2-33
2.5.5 Power, Location, and Cooling	2-35
2.5.6 Interfaces	2-36
2.5.7 Controls and Displays	2-38
2.5.8 Major Function Switches	2-38
2.5.9 IDP Load Switch	2-38

Section	Page
2.6 MASTER TIMING UNIT	2-39
2.6.1 Description	2-39
2.6.2 Interfaces	2-40
2.6.3 Controls and Displays	2-41
2.6.4 Power, Location, and Cooling	2-42
3.0 PRIMARY AVIONICS SOFTWARE SYSTEM.....	3-1
3.1 CONCEPT AND DEFINITIONS	3-1
3.1.1 Flight Computer Software	3-1
3.1.2 Displays	3-2
3.1.3 GPC Modes	3-4
3.1.4 Synchronization	3-6
3.1.5 Data Bus Assignment.....	3-7
3.1.6 Memory Configurations	3-8
3.1.7 Nominal Bus Assignment Table	3-10
3.1.8 Memory Reconfiguration	3-13
3.1.9 OPS 0	3-15
3.1.10 Freeze-Dried GPC	3-15
3.1.11 Sample Procedure: Config GPCs for OPS 2.....	3-17
3.1.12 MMU Assignment.....	3-23
3.1.13 Memory Source Selection During Initial Program Load.....	3-24
3.1.14 Checkpoint	3-26
3.2 SYNCHRONIZATION AND GPC REDUNDANCY MANAGEMENT	3-28
3.2.1 Common Set	3-28
3.2.2 Redundant Set	3-29
3.2.3 GPC Redundancy Management	3-29
3.2.4 GPC Fail Annunciations	3-30
3.2.5 GPC FAIL Procedures	3-35
3.2.6 Redundant Set Fail On Orbit.....	3-38
3.2.7 Input/Output Management	3-41
3.2.8 I/O Transaction	3-41
3.2.9 I/O Error Handling	3-42
3.2.10 BTU Bypass	3-45
3.2.11 Bus Masking	3-48
3.2.12 Resetting Comm Faults.....	3-50
3.2.13 Port Moding.....	3-51
3.2.14 Mass Memory I/O Management.....	3-55
3.2.15 Display Electronics Unit/Keyboard Data Bus I/O Management....	3-56

Section	Page	
3.3	TIME MANAGEMENT	3-60
3.3.1	GPC Time Source Selection	3-61
3.3.2	Time Update	3-62
3.3.3	CRT Timers.....	3-63
3.3.4	Alert Tones.....	3-65
3.3.5	Alert Tone Initiation	3-65
3.4	GPC READ/WRITE.....	3-66
3.4.1	Memory Read Operations	3-67
3.4.2	Memory Write Operations	3-68
3.4.3	Bit Set/Reset Operations.....	3-69
3.5	DOWNLIST	3-72
3.5.1	Composition of the Downlist.....	3-73
3.5.2	Variable Parameters	3-74
3.5.3	Downlist GPC.....	3-75
3.5.4	GPC Downlist/PCMMU Interface	3-77
3.5.5	Telemetry Format Load.....	3-77
3.5.6	Loss of Downlist.....	3-81
3.5.7	Memory Dumps.....	3-81
3.6	UPLINK.....	3-86
3.6.1	Uplink Command Flow	3-86
3.6.2	Types of Uplink Commands	3-87
3.6.3	Uplink Control	3-89
3.7	INITIALIZATION AND RECOVERY	3-92
3.7.1	IDP Initialization and Recovery	3-92
3.7.2	GPC Initialization and Recovery	3-93
3.7.3	In-Flight Maintenance.....	3-97
4.0	BACKUP FLIGHT SOFTWARE.....	4-1
4.1	CONCEPTS AND DEFINITIONS	4-1
4.1.1	Backup Flight Software	4-1
4.1.2	Displays	4-2
4.1.3	GPC Mode Switch.....	4-3
4.1.4	Synchronization	4-4
4.1.5	Data Bus Assignment.....	4-5
4.1.6	Memory Configuration.....	4-6
4.1.7	Memory Reconfiguration	4-6
4.1.8	Checkpoint	4-6
4.2	SYNCHRONIZATION AND GPC REDUNDANCY MANAGEMENT	4-7
4.2.1	Tracking the PASS.....	4-7
4.2.2	Standalone BFS.....	4-7
4.2.3	BFS GPC RM and Annunciations	4-8
4.2.4	BFS Fail Procedures	4-9

Section	Page	
4.3	INPUT/OUTPUT MANAGEMENT	4-11
4.3.1	PASS to BFS Transfers	4-11
4.3.2	I/O Error Handling	4-14
4.4	BUS MASKING	4-15
4.4.1	Resetting Comm Faults.....	4-16
4.4.2	Port Moding.....	4-16
4.4.3	Mass Memory I/O Management.....	4-16
4.4.4	DK I/O Management	4-16
4.5	TIME MANAGEMENT	4-18
4.5.1	Time Source Selection	4-18
4.5.2	Time Updates.....	4-19
4.5.3	CRT Timers.....	4-19
4.6	GPC READ/WRITE	4-20
4.6.1	Downlist	4-20
4.6.2	Composition of the Downlist.....	4-20
4.6.3	BFS Downlist/PCMMU Interface	4-21
4.6.4	Telemetry Format Load.....	4-21
4.6.5	Loss of Downlist.....	4-22
4.6.6	Memory Dumps.....	4-22
4.7	UPLINK.....	4-24
4.7.1	Uplink Command Flow	4-24
4.7.2	Types of Uplink Commands	4-24
4.7.3	Uplink Control	4-24
4.8	INITIALIZATION AND RECOVERY	4-24
4.8.1	BFS GPC IPL.....	4-24
4.8.2	IDP IPL.....	4-28
4.9	BFS ENGAGE.....	4-29
4.10	BFS DISENGAGE.....	4-32

Appendix

A	ACRONYMS AND ABBREVIATIONS	A-1
B	SUGGESTED REFERENCE DOCUMENTS.....	B-1

FIGURES

Figure	Page
2-1 AP-101S block diagram.....	2-2
2-2 GPC 1 discrete input lines (typical of all five GPCs).....	2-4
2-3 GPC 1 discrete output lines (typical of all five GPCs).....	2-5
2-4 Computer data bus, MIA, and BCE.....	2-6
2-5 GPC locations.....	2-7
2-6 GPC controls and displays (Panel O6).....	2-9
2-7 Computer data bus network.....	2-12
2-8 Orbiter FC data buses.....	2-13
2-9 Components of string one.....	2-14
2-10 Payload data buses.....	2-15
2-11 Launch data buses.....	2-16
2-12 IP computer data bus interface.....	2-17
2-13 Intercomputer communication data buses.....	2-18
2-14 Shuttle vehicle MDMs.....	2-20
2-15 MDM functional block diagram.....	2-21
2-16 Reference data.....	2-23
2-17 MDM controls on Panel O6.....	2-24
2-18 Modular Memory Unit functional block diagram.....	2-25
2-19 SSMM functional block diagram.....	2-26
2-20 MM data buses.....	2-27
2-21 MMUs 1 and 2 switches.....	2-28
2-22 Forward MEDS MDUs.....	2-29
2-23 MEDS interface.....	2-30
2-24 Integrated display processor.....	2-31
2-25 IDP and ADC flight deck LRU locations.....	2-32
2-26 Multifunction display unit.....	2-33
2-27 MDU configuration.....	2-34
2-28 Analog-to-digital converter.....	2-35
2-29 Keyboard.....	2-36
2-30 DPS keyboard and MDU locations.....	2-37
2-31 IDP controls (forward station).....	2-39
2-32 GPC/MTU operational interface.....	2-41
2-33 Timers.....	2-42
3-1 Orbiter flight computer software.....	3-3
3-2 Keyboard entries resulting in display changes.....	3-4
3-3 Panel O6.....	3-5
3-4 SPEC 6 - GPC/BUS STATUS display.....	3-6
3-5 GPCs communicating with Flight Forward MDM 1.....	3-8
3-6 Applications software memory configurations.....	3-9
3-7 SPEC 0 - GPC MEMORY display.....	3-10

Figure	Page
3-8 GPC MEMORY display	3-11
3-9 NBAT configuration	3-12
3-10 GPC/BUS STATUS display	3-13
3-11 GPC MEMORY display	3-17
3-12 Post-Insertion Checklist.....	3-19
3-13 SPEC 1 - DPS UTILITY display.....	3-23
3-14 GPC MEMORY display	3-24
3-15 Panel O6	3-25
3-16 DPS UTILITY display.....	3-26
3-17 SPEC 60 - SM TABLE MAINT display.....	3-27
3-18 DPS UTILITY display.....	3-28
3-19 Panel O1	3-31
3-20 Panel F7	3-32
3-21 GPC MEMORY display	3-32
3-22 GPC/BUS STATUS display	3-33
3-23 CAM	3-34
3-24. NC SYS SUMM display	3-34
3-25 Ascent Pocket Checklist	3-35
3-26 Orbit Pocket Checklist	3-37
3-27 Panel O1	3-38
3-28 GPC/BUS STATUS display	3-39
3-29 GPC 1 SYS SUMM display.....	3-40
3-30 GPC 2 SYS SUMM display.....	3-40
3-31 Ascent Pocket Checklist	3-44
3-32 Reference data.....	3-45
3-33 GNC SYS SUMM 1 display	3-46
3-34 GPC/BUS STATUS display	3-46
3-35 Orbit Pocket Checklist	3-47
3-36 GPC 1 SYS SUMM display.....	3-48
3-37 GPC 3 SYS SUMM display.....	3-49
3-38 GPC/BUS STATUS display	3-50
3-39 GPC MEMORY display	3-51
3-40 PL MDM primary and secondary modes	3-52
3-41 DPS UTILITY display.....	3-53
3-42 String 1 primary and secondary modes	3-54
3-43 DPS UTILITY display.....	3-56
3-44 Panel C2.....	3-57
3-45 GPC MEMORY display	3-57
3-46 Keyboard	3-58
3-47 Panel C3.....	3-58
3-48 Big "X" POLL FAIL.....	3-60
3-49 SPEC 2 - TIME display.....	3-61
3-50 TIME display.....	3-62
3-51 MNVR display.....	3-65
3-52 TIME display.....	3-66

Figure	Page
3-53 GPC MEMORY display	3-67
3-54 GPC MEMORY display	3-70
3-55 Malfunction procedures	3-71
3-56 Functional real-time downlink data flow	3-74
3-57 DPS UTILITY display	3-75
3-58 GPC MEMORY display	3-76
3-59 Toggle buffers.....	3-78
3-60 Panel C3.....	3-78
3-61 SPEC 62 - PCMMU/PL COMM display	3-79
3-62 Orbit OPS Checklist.....	3-80
3-63 GPC MEMORY display	3-82
3-64 Malfunction procedures for software dump.....	3-83
3-65 Panel MO42F	3-84
3-66 Malfunction procedures for hardware dump	3-85
3-67 SPEC 85 - MASS MEMORY R/W display	3-86
3-68 Uplink command flow	3-87
3-69 DPS UTILITY display.....	3-88
3-70 Panel C3.....	3-90
3-71 DPS UTILITY display.....	3-91
3-72 Panel O6 - IDP load switches	3-92
3-73 Malfunction procedures	3-94
3-74 Panel C3.....	3-96
3-75 Panel O6	3-96
4-1 SPEC 0 - BFS MEMORY display	4-3
4-2 BFS FAULT display	4-3
4-3 Panel O6	4-4
4-4 BFS MEMORY display	4-5
4-5 Panel C3.....	4-6
4-6 Panel F2	4-8
4-7 Panel O6	4-9
4-8 Entry Pocket Checklist.....	4-10
4-9 SPEC 50 - BFS HORIZ SIT display	4-12
4-10 Ascent Checklist.....	4-13
4-11 BFS MEMORY display	4-13
4-12 SPEC 100 - GTS DISPLAY (PASS)	4-14
4-13 BFS GNC SYS SUMM 1 display	4-15
4-14 Panel C3.....	4-17
4-15 Keyboard	4-18
4-16 BFS MNVR display	4-19
4-17 BFS MEMORY display	4-20
4-18 Panel C3.....	4-21
4-19 Malfunction procedures (S/W dump)	4-23
4-20 Malfunction procedures (menu option)	4-26
4-21 IPL MENU display	4-28

Figure		Page
4-22	Rotational hand controller	4-29
4-23	Panel F2	4-30
4-24	Panel O6	4-31
4-25	Panel C3.....	4-31
4-26	Panel O1	4-32
4-27	Panel F6	4-33

1.0 INTRODUCTION

1.1 PURPOSE OF THE DATA PROCESSING SYSTEM

The successful performance of a complicated spaceflight depends heavily on the use of a computerized system for controlling and monitoring the entire space vehicle. The Data Processing System (DPS), through the use of its various hardware components and its self-contained computer programming (software), provides the vehicle with systems monitoring and flight control support. Some of the functions of the DPS are as follows:

- Supports the guidance, navigation, and control requirements of the vehicle, including calculations of trajectories, engine burn data, and vehicle attitude control data.
- Provides for the monitoring and control of vehicle subsystems, such as electrical power and environmental control.
- Processes vehicle systems data and provides this data for transmission to the ground. It also allows for ground control of the vehicle via transmitted commands.
- Provides for checking of data transmission errors and crew control input errors, and supports the annunciation of vehicle systems failures and out-of-tolerance conditions.
- Supports payloads, as required, by providing the crew-software interface for activation and deployment as well as processing rendezvous, tracking, and data transmission between payloads and the ground.

Although it is impossible to completely separate hardware and software, this book has been divided into hardware and software sections to facilitate the presentation of this complicated system. The hardware section explains the basic functions and interfaces of each unit, and the software sections explain how the system operates from the crew's point of view. The primary flight software, called the Primary Avionics Software System (PASS), is included in Section 3, while the Backup Flight Software (BFS) is presented in Section 4, with all topics in the same order as those in Section 3 for easy comparison.

1.2 DPS HARDWARE OVERVIEW

The main components of the DPS are as follows:

- General Purpose Computers (GPCs)
- Computer data bus network
- Multiplexer/Demultiplexers (MDMs)
- Modular Memory Units (MMUs)
- Multifunction Electronic Display System (MEDS)
- Master Timing Unit (MTU)

2.0 HARDWARE

2.1 GENERAL PURPOSE COMPUTERS

2.1.1 Description

There are five identical GPCs onboard the orbiter that control all orbiter systems and functions. They are all IBM AP-101S type computers. Each computer consists of a Central Processing Unit (CPU), an Input/Output Processor (IOP), one megabyte of memory, and various other components contained in an Electromagnetic Interference (EMI) hardened case. See Figure 2-1.

The CPU has the following purpose:

- To execute instructions to perform vehicle systems control and data manipulation

The IOP has the following purposes:

- To format and transmit commands to the vehicle systems
- To receive and validate response data from the vehicle systems
- To maintain the status of the interfaces with the CPU and the other GPCs

In other words, the CPU is basically the “number cruncher” that does the computing and controlling of computer functions, while the IOP does all the interfacing with the rest of the GPCs and all other vehicle systems. (The AP-101S actually uses three CPUs working together in order to increase throughput speed. This fact is transparent to the user.) One may sometimes hear of CPU in terms of percent. CPU is also used as an abbreviation for the total computing ability of a GPC. In other words, a GPC that is executing as many instructions as its main memory size and speed allow is operating at 100 percent CPU.

The GPC control logic directs the activities of the GPC in order to accomplish tasks and schedule transmission and reception of data. This is done through both hardwired (microprogram) and software instructions.

The memory of each GPC consists of complementary metal oxide semiconductor (CMOS)-type integrated circuit chips. It is divided into two halves, referred to as upper and lower memory. The CPU can access both halves; the IOP can access only the lower half. This is a hardware limitation of the addressing capability of the IOP. The upper memory is used only to store a copy of the software to be used for the entry phase of flight, much like a Random Access Memory (RAM) disk. It is copied to lower memory when needed. More information on this follows. With the delivery of the OI-25 flight software, some active software was moved to upper memory and can only be accessed by the CPU. The CPU fetches any data needed by the IOP from this area and copies it to lower memory.

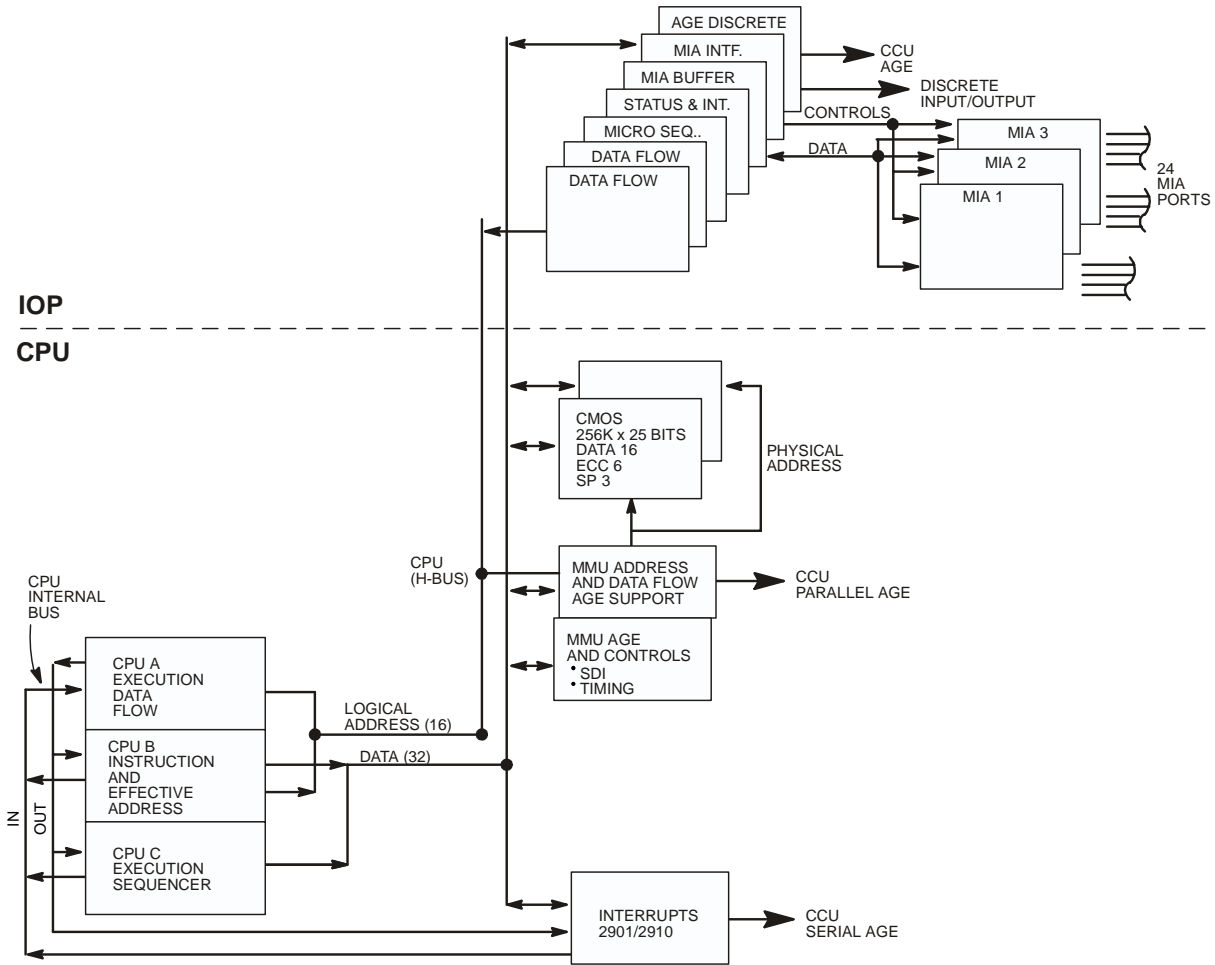

usa005350_431

Figure 2-1. AP-101S block diagram

Since the GPCs are operated in 16-bit (halfword) mode, there is a maximum of 512k instructions and data available at any one time in a given GPC (minus the memory used for the entry software stored in upper memory). Also, this memory is volatile (lost if the power is interrupted) and prone to corruptions by radiation (“bit flips”). Thus, there are additional bits of memory for each halfword that are used for Error Correcting Code (ECC), parity checking, and code-overwrite protection. A separate microprocessor performs the error correction. In addition, rechargeable batteries (internal to the GPC case) are used to back up the regular power to the memory chips in order to preserve the programming in the event the GPC is powered off (so it can be dumped for post-flight analysis).

For timing, each GPC contains oscillators that send signals to internal components to regulate operations. The GPC also uses the oscillator to maintain an internal clock to keep track of Greenwich Mean Time (GMT) and Mission Elapsed Time (MET) as a backup to the timing signal from the MTU, which is discussed later.

Since the GPC that contains the BFS does not operate in sync with other GPCs that can check its proper functioning, there is a watchdog timer in each GPC. The watchdog timer is an incrementing clock register, which is reset about once every second by a signal from the CPU. If the timer ever overflows (3.6 seconds), then a problem exists and is annunciated by a self-fail indication from that GPC. The software to update the timer is available only in BFS, and the timer is not used in the PASS GPCs.

The PASS GPCs use a hardware “voter.” The function of this voter is to monitor discrete inputs from the other GPCs. If it receives a FAIL VOTE received from two or more of the other GPCs, it causes the GPC to consider itself failed and to annunciate a self-fail indication. It also causes the “failed” GPC to inhibit any fail votes against the “good” GPCs.

To conserve orbiter consumables, the GPCs have a power-saving mode, called “sleep mode.” If a GPC is placed in HALT and left there (with certain discrete inputs equal to “zero”) for 4.5 minutes, it reduces its power draw from 560 to 56 watts. The memory chips remain powered, and the microprocessor that performs the error correction continues to perform its function. This action ensures the integrity of the GPC programming.

2.1.2 Interfaces

Each GPC communicates with the other GPCs and with other vehicle hardware via discrete signal lines and serial digital data buses. Discrete lines transmit a signal that indicates a binary condition (e.g., on or off). Data buses transmit serial digitized data with information about several systems and many different values.

2.1.2.1 Discrete Input and Output Registers

There are 44 discrete input registers in the IOP that accept and buffer discrete inputs from the GPCs, crew station switches, the mass memories, and the Backup Flight Controllers (BFCs). The 37 discrete output registers set or reset discrettes (as directed by the control logic or voter) to the GPCs, crew station displays, and the Caution and Warning (C&W) system.

If a GPC fails or stops processing software entirely, it ceases to update its discrete outputs. If any are set to a “one,” they remain so. If the GPC is powered off or loses power, the discrete outputs go to zero.

The discrete input and output lines are shown in Figure 2-2 and Figure 2-3, respectively.

The discrete inputs from the GPC switches and the discrete outputs to the talkbacks and C&W system are described in Concepts and Definitions, Section 3.1.

The sync and fail vote discrettes are described in Section 3.

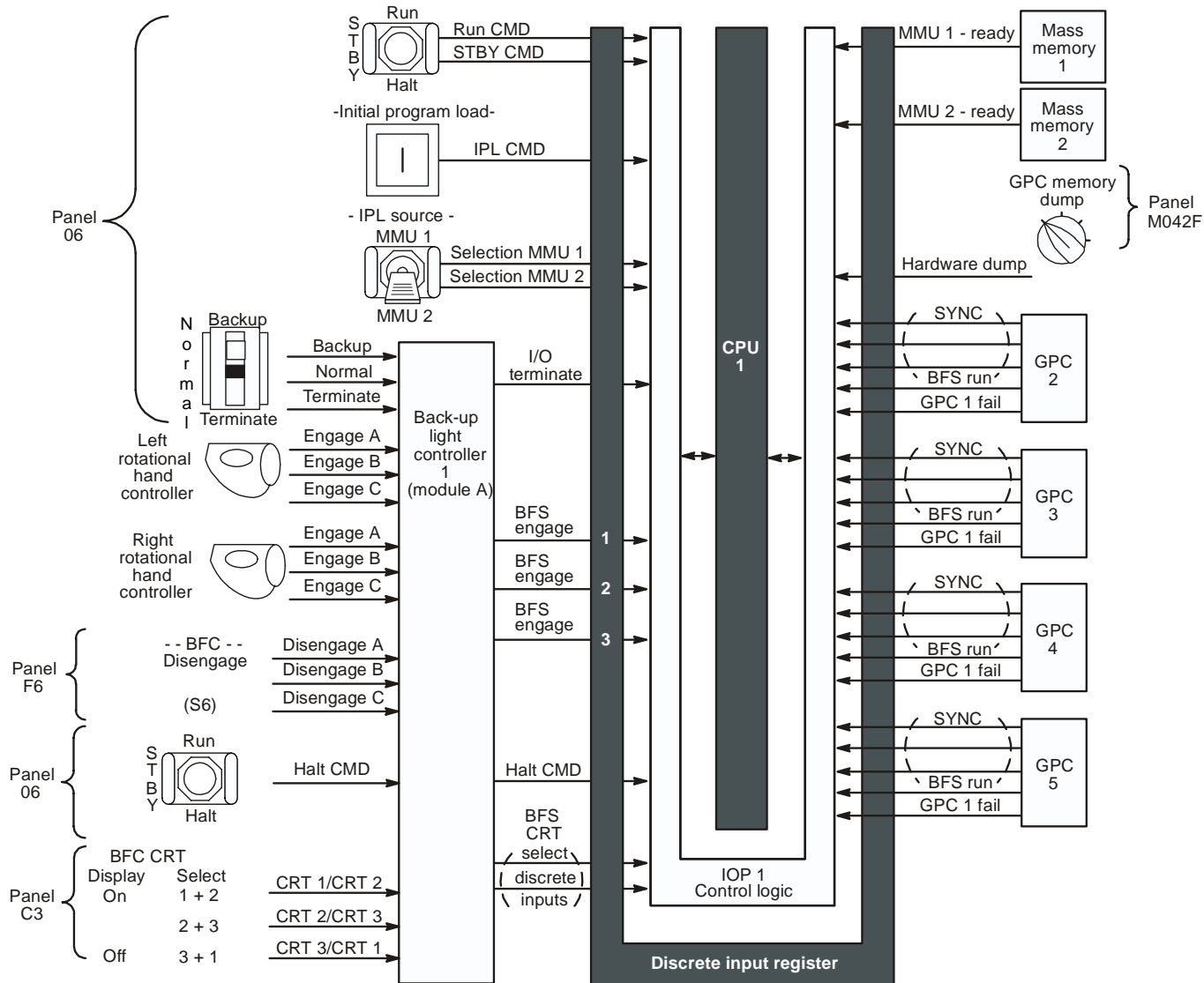

usa005350_004

Figure 2-2. GPC 1 discrete input lines (typical of all five GPCs)

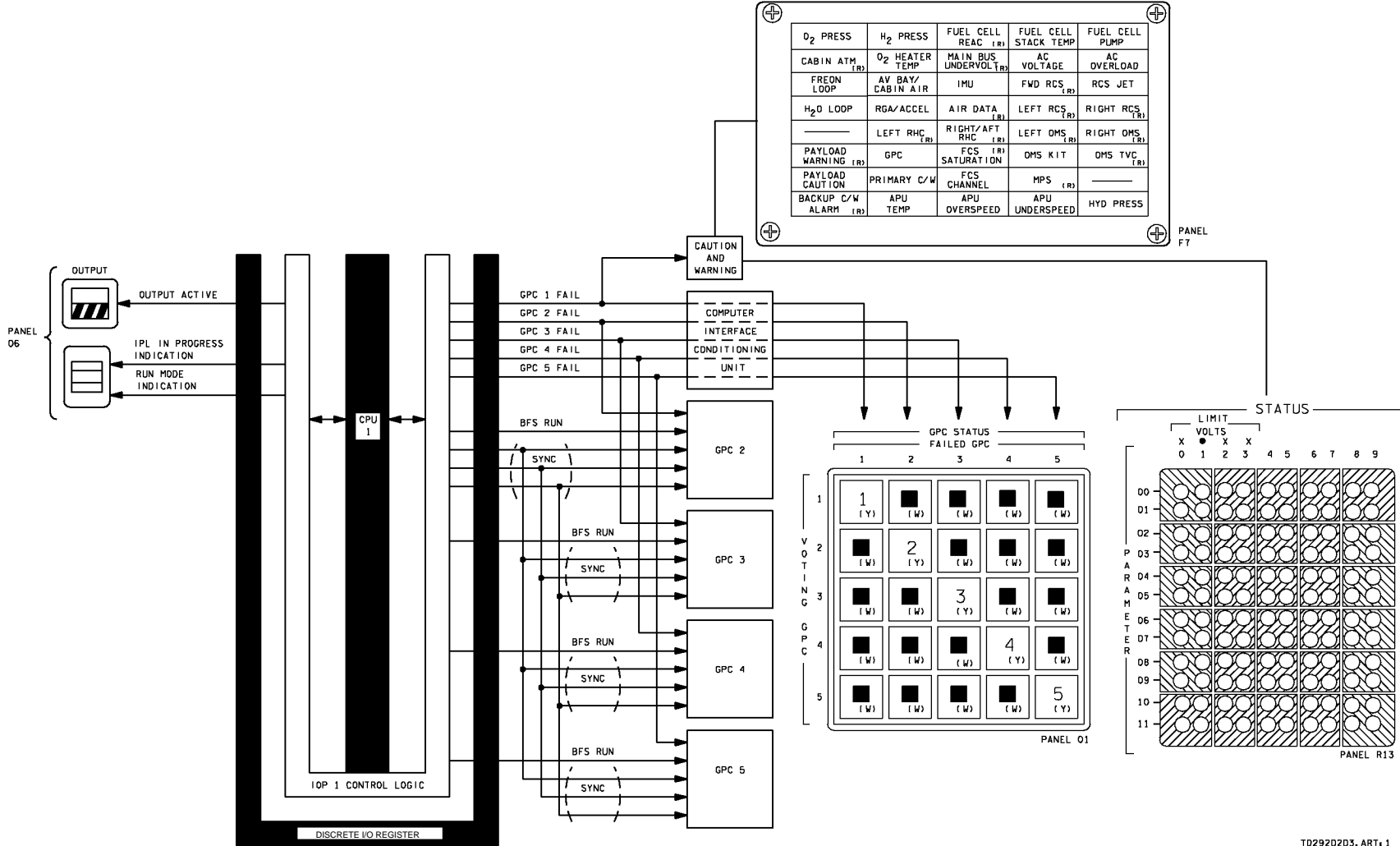

TD2920203. ART 1

Figure 2-3. GPC 1 discrete output lines (typical of all five GPCs)

2.1.2.2 Serial Digital Data Bus Interface

A GPC interfaces with the serial digital computer data bus network via two hardware components in the IOP: Bus Control Elements (BCEs) and Multiplexer Interface Adapters (MIAs). Twenty-four BCE/MIA pairs execute instructions to transmit commands and receive data from vehicle hardware items called Bus Terminal Units (BTUs). Essentially, a BTU can be considered as any equipment that communicates with the GPCs over a data bus through an MIA (e.g., mass memories, display electronics units, and MDMs are BTUs).

The BCEs add the appropriate BTU address and special bit pattern to words scheduled for transmission prior to shipping the data to its associated MIA. The BCEs also validate data received from and transmitted to their associated MIAs and notify the IOP control logic in the event an error is detected.

The MIAs, which are commonly referred to as “ports,” have two modes of operation: transmit and receive.

During the transmit mode, a MIA, which transmits and receives in 28-bit words over the computer data buses, adds the appropriate parity and sync code bits to the data word, formats the data, and sends the data out over the data bus. In this mode, the MIA receiver and transmitter are both enabled.

As can be seen in Figure 2-4, the BTU on the other end of the data bus also has its own MIA with functions that are similar to those of the IOP MIA.

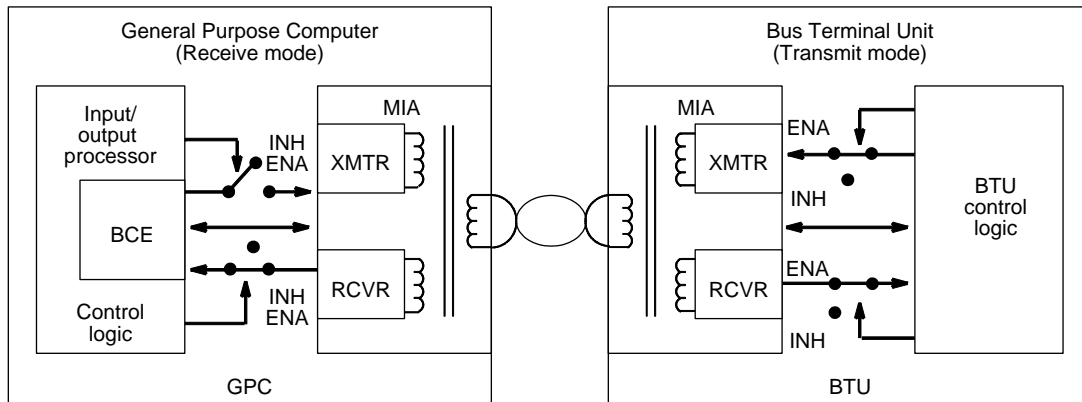

td_292_204

Figure 2-4. Computer data bus, MIA, and BCE

2.1.3 Power, Location, and Cooling

The three essential buses (ESS 1BC, 2CA, 3AB), which go through the GPC power switches on Panel O6, enable power to the five GPCs. The essential bus power actuates Remote Power Controllers (RPCs), which allow main bus power from the three main buses (MNA, MNB, MNC) to flow to the GPCs. There are three RPCs for the CPU and BFC. Therefore, any GPC is still able to function, even if two main or essential buses are lost. Each GPC uses 560 watts of power in normal operation.

The GPCs are located sequentially in the forward avionics bays (AV Bay 1, 2, 3), as shown in Figure 2-5.

The GPCs receive forced-air cooling from the avionics bay fans. There are two fans in each bay (only one is powered at a time). If both fans in a bay are lost, the GPC(s) will begin to overheat and cannot be relied on to operate properly after as little as half an hour without cooling (when in RUN at the time of cooling loss). They can operate indefinitely without forced-air cooling while in sleep mode.

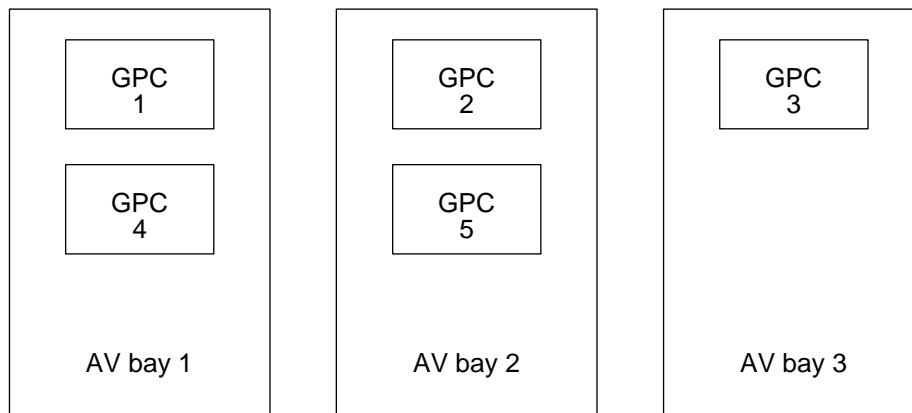

td_292_205

Figure 2-5. GPC locations

2.1.4 Controls and Displays (Hardware)

The principal hardware controls for the GPCs are located on Panel O6 (Figure 2-6). These controls include power switches, output switches, Initial Program Load (IPL) pushbuttons (pb's), and mode switches for each of the five GPCs. The GPC reads the positions of these controls via discrete input lines that go directly to the GPC from the switch or pb (unless they are first routed through the BFC, which is a separate black box that controls the BFS engage logic and the BFS Cathode Ray Tube (CRT) selection). Also on this panel are two sets of talkbacks (OUTPUT and MODE), which are driven directly from GPC output discretetes.

a. POWER switch

The farthest aft row contains the power switches, which are covered by switch guards. Placing a switch in the ON position provides the GPC with triply redundant power via RPCs from the three main buses.

b. OUTPUT switch

The output switches (which are also guarded) have three positions: BACKUP, NORMAL, and TERMINATE. One purpose of the OUTPUT switch is to provide a hardware override (the I/O TERM B discrete input), which precludes a GPC from transmitting on the flight-critical data buses. The PASS Guidance, Navigation, and Control (GNC) GPCs are placed in NORMAL, which allows output. The System Management (SM) GPC is kept in TERMINATE since it is not supposed to command anything on the flight criticals. The BFS is placed in BACKUP, which precludes it from outputting until such time as it is engaged. The statuses of these switches are sent to the BFCs, which determine the engage condition and send the appropriate discrete inputs on to the GPCs.

c. OUTPUT talkback

Directly above each OUTPUT switch is a talkback (tb) that specifies whether the GPC is capable of outputting GNC commands. A discrete output from the GPC drives the talkback to gray if output is enabled, and the talkback goes barberpole (bp) if it is not (I/O TERM B set or the GPC not in RUN).

d. MODE switch

The GPC receives discrete inputs from the MODE switch that determine if the GPC can process software. The RUN discrete allows normal processing of all active software. The standby (STBY) discrete from the mode switch places the GPC under software control and allows for an orderly startup or shutdown of processing in PASS. (The software running in a GPC in STBY is a small subset of the full PASS software. No synchronization or data bus input/output occurs; only discrete inputs/outputs are processed.) The HALT command places the GPC under hardware control, which inhibits any software execution (except IPL).

It should be noted here that the STBY discrete to the BFS GPC does not stop BFS software processing or preclude a BFS engage. It only prevents the BFS from commanding the payload data buses (pre-engaged). The MODE switches are discussed in more detail in Sections 3 and 4.

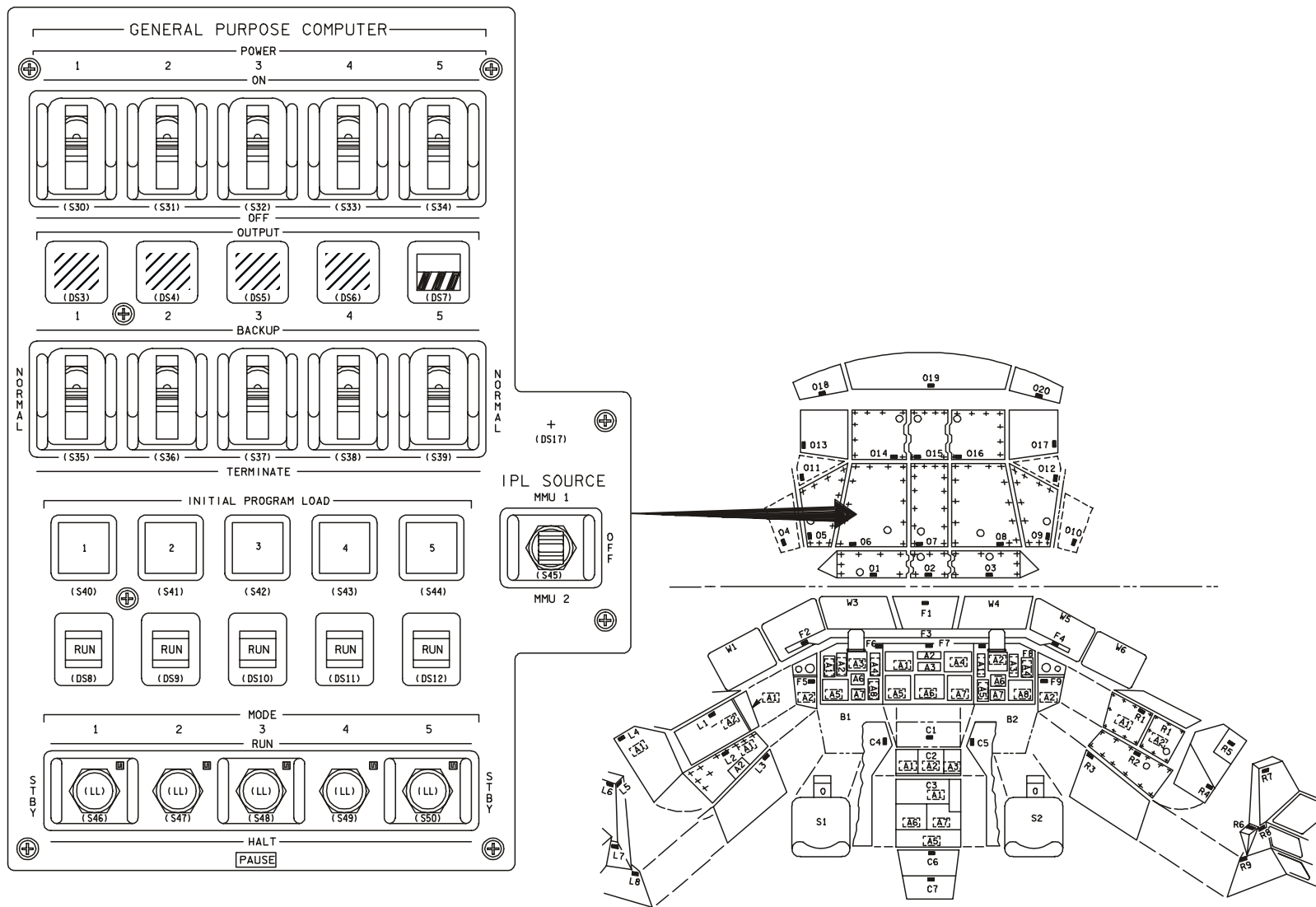

USA005350_0206-P01

Figure 2-6. GPC controls and displays (Panel O6)

e. IPL pushbutton

In the middle of the panel are pb's that activate the IPL command discrete input to the GPCs. When this input is received, the GPC initiates an IPL (i.e., boot) from whichever MMU is specified by the IPL SOURCE switch to the right of the pb's. The IPL procedure is described in Section 3.

f. MODE talkback

The tb's between the IPL pb's and MODE switches have three positions: RUN, IPL, and barberpole. They are also driven by discrete outputs from the GPC and are explained in detail in Section 3.

Other hardware controls that provide discrete inputs to the GPCs include the BFC CRT DISPLAY and SELECT switches, which specify which CRT is to be driven by the BFS; the BFC DISENGAGE switch, which allows recovery of the PASS on orbit after a BFS engage; and the BFS ENGAGE pb's on the left and right Rotational Hand Controllers (RHCs) used to engage the BFS. All these discrettes go through the BFC for processing before being sent to the GPCs. There is more on these controls in later sections.

As described in Section 3, there is also a discrete input to the GPCs from the GPC MEMORY DUMP switch on Panel MO42F, and there are discrete outputs from the GPCs to the GPC status matrix and the C&W system for GPC failures.

2.2 COMPUTER DATA BUS NETWORK

The orbiter computer data bus network consists of a group of twisted, shielded-wire pairs (data buses), which support the transfer of serial digital commands from the GPCs to vehicle hardware and the transfer of vehicle systems data (serial) to the GPCs. As shown in Figure 2-7, the computer data bus network is divided into specific groups that perform specific functions. These groups are as follows:

- a. Flight Critical (FC) data buses that tie the GPCs to the FC MDMs, Display Driver Units (DDUs), MEDS, Heads-Up Displays (HUDs), Engine Interface Units (EIUs), and Master Events Controllers (MECs)
- b. Payload (PL) data buses that tie the GPCs to the PL MDMs and the Payload Data Interleaver (PDI), as well as the flex MDMs (if any) and sequence control assemblies (if any)
- c. Launch/Boost (LB) data buses that tie the GPCs to the ground support equipment, Launch Forward (LF), Launch Mid (LM), and Launch Aft (LA) MDMs, Solid Rocket Booster (SRB) MDMs, and the Manipulator Controller Interface Unit (MCIU)
- d. Mass Memory (MM) data buses for GPC/mass memory unit transactions
- e. Display/Keyboard (DK) data buses for GPC/MEDS transactions

- f. Instrumentation/Pulse-Code Modulation Master Unit (IP) data buses for GPC/Pulse Code Modulation Master Unit (PCMMU) transactions
- g. Intercomputer Communication (ICC) data buses for GPC-to-GPC transactions

Even though all the data buses except the IP data buses are connected to all five GPCs, only one GPC at any given time commands (i.e., transmits commands over) each bus. However, several GPCs may “listen” (receive data) to the same bus simultaneously. The crew can select which GPC commands a given bus via the software, and this procedure is described in Section 3.

2.2.1 Flight Critical Data Buses

There are eight FC data buses onboard the orbiter. As can be seen in the Figure 2-8, four of these FC buses (FCs 1 to 4) connect the GPCs with the four Flight Critical Forward (FF) MDMs, the four Flight Critical Aft (FA) MDMs, the three DDU's (or Integrated Display Processors (IDPs)), and the two HUDs. The other four FC buses (FCs 5 to 8) connect the GPCs to the four FF MDMs, the four FA MDMs, the two MECs, and the three EIUs. The specific manner in which these units are interfaced is referred to by the term “string.” In essence, a string is composed of two FC data buses (one of the first group and one of the second group), the BTUs connected to them (DDUs, IDPs, HUDs, MDMs, MECs, and EIUs), and all the hardware, which is hardwired to those BTUs.

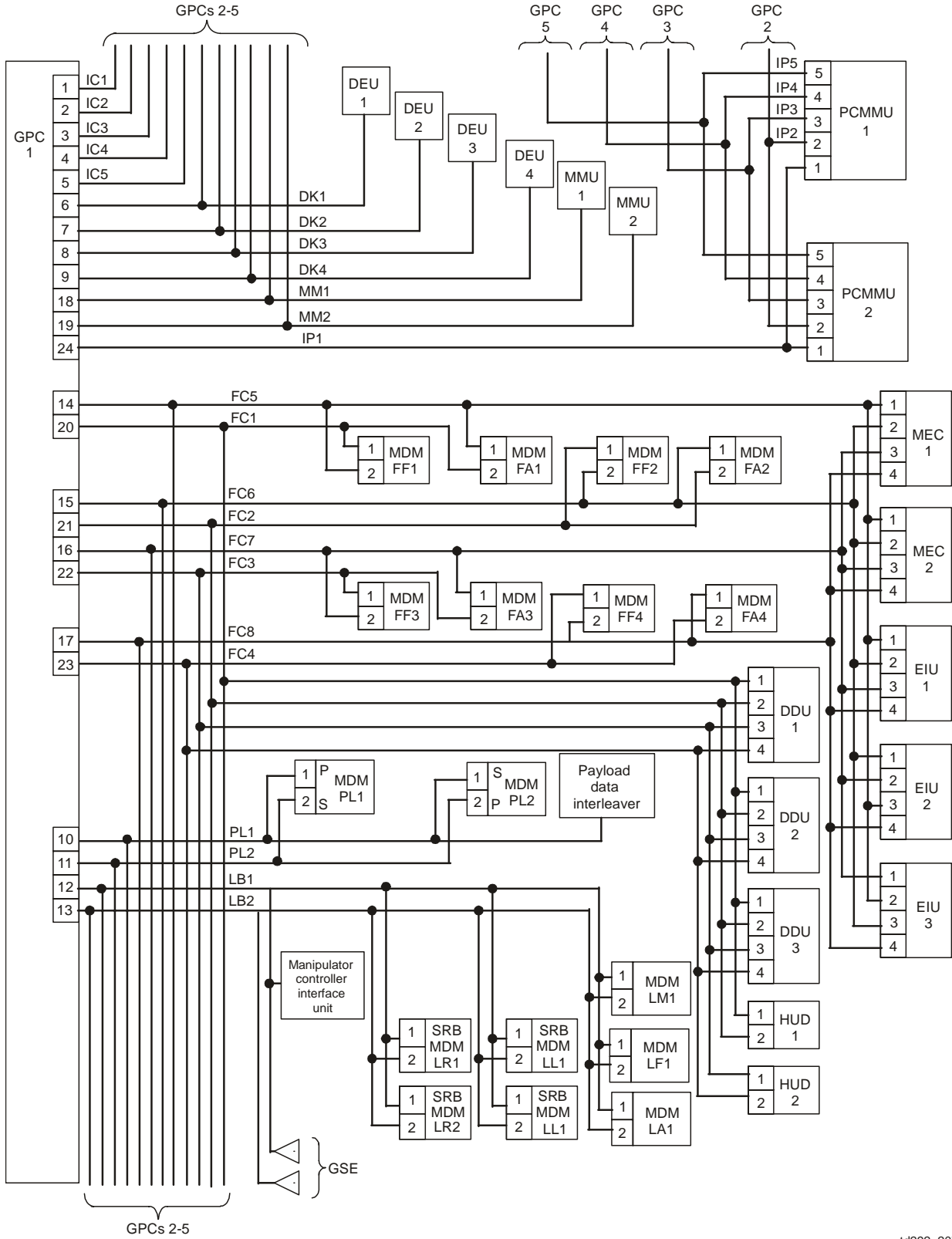

Figure 2-7. Computer data bus network

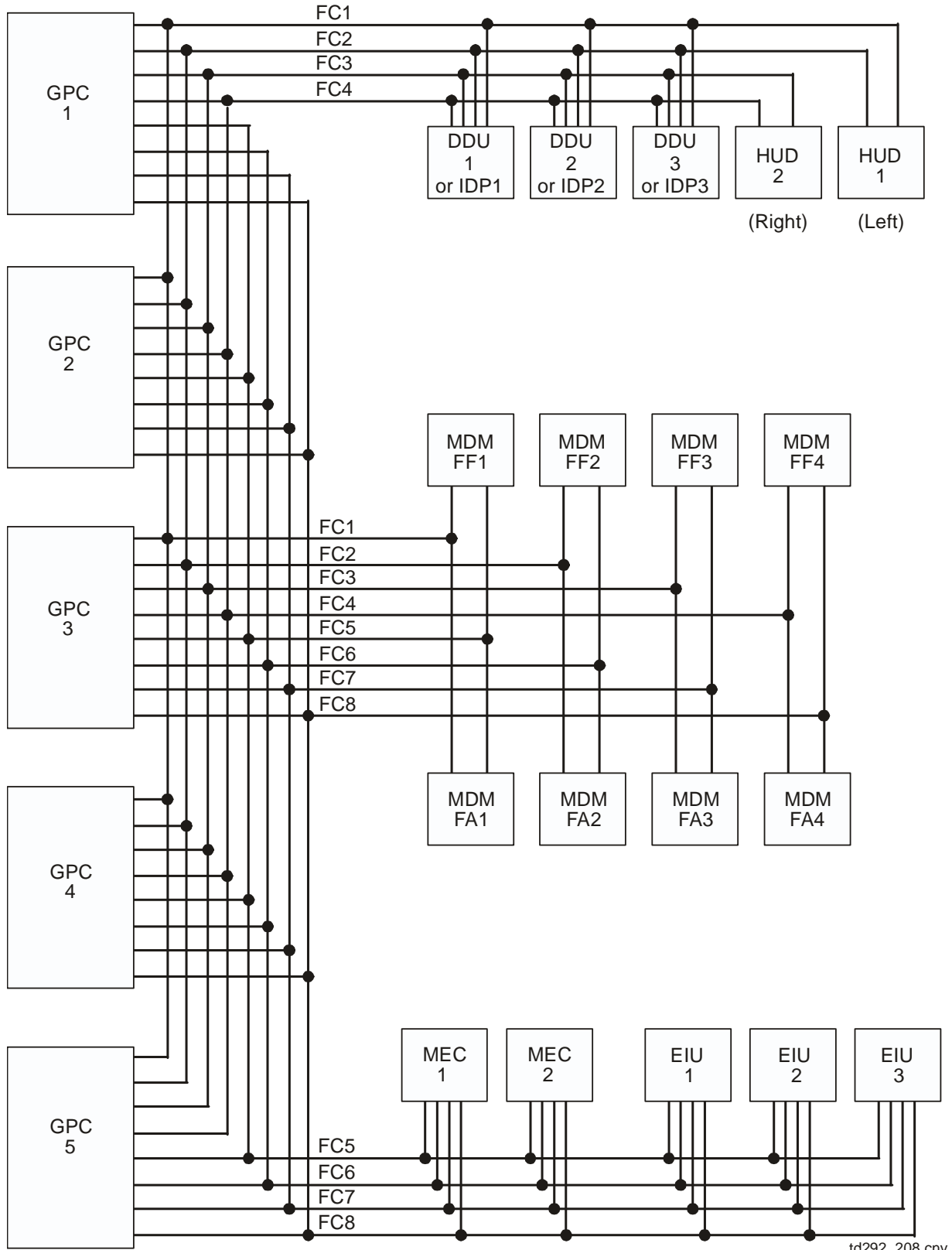

Figure 2-8. Orbiter FC data buses

For example (see Figure 2-9), string 1 consists of FC data buses 1 and 5; MDMs FF1 and FA1 and their hardwired hardware, controls, and displays; the three EIUs; the two MECs; HUD 1; and the three IDPs or DDUs and their associated displays. Four strings are defined in this way.

The functional purpose of the string concept is to provide failure protection capability during dynamic phases by allowing exclusive command of a specific group of shuttle vehicle hardware by one GPC, which can be transferred to another GPC in case of a failure. All FC units are redundant and the redundant units are all on different strings. Thus, all or part of one string can be lost and all functions are still retained via the other strings.

This configuration also allows more redundancy since each FF and FA MDM is connected to the GPCs via two FC data buses. Thus, if one MIA or port in an MDM fails, interface to the GPC can be reestablished by switching to the other port (i.e., port moding). More detail is given in Section 3.

Note that the other BTUs are also connected to multiple buses. A DATA BUS SELECT switch for each DDU (and HUD of the same number) determines which bus is controlling each unit in MCDS-equipped vehicles. For MEDS vehicles, display edgekeys select which bus drives the displayed instruments. The MECs and EIUs have their own internal logic to determine the appropriate buses for commands and data. As such, only one of the four data/command paths (MIAs) for each IDP, DDU, MEC, and EIU is part of any one string. Therefore, these units can still be controlled by other strings when one string is lost (as opposed to the MDMs, which are controlled by one of two buses on the same string).

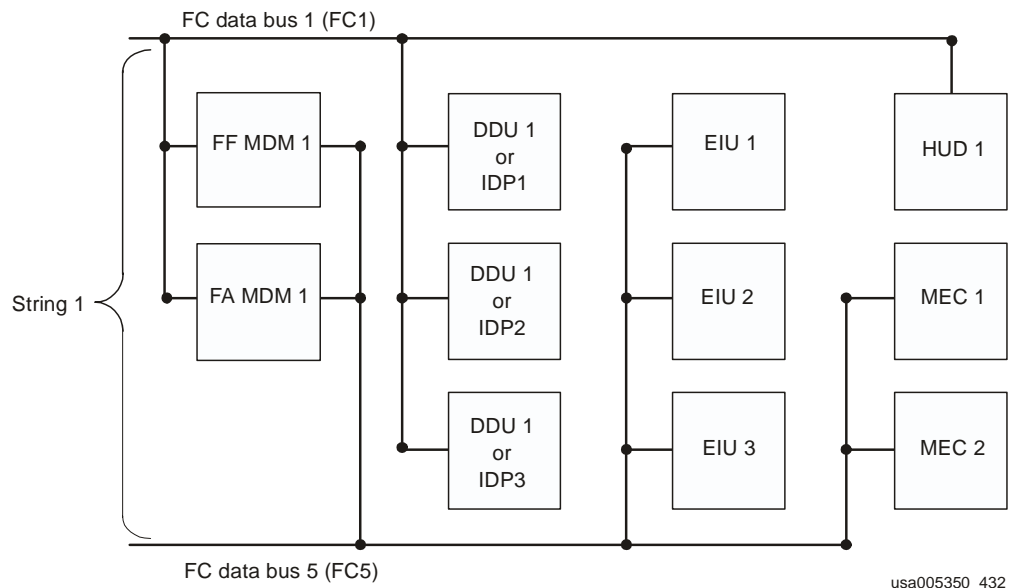

Figure 2-9. Components of string one

2.2.2 Payload Data Buses

There are two PL data buses onboard the orbiter that interface the five GPCs with the two PL MDMs (sometimes called Payload Forward (PF) MDMs) that, in turn, interface

with orbiter systems and payloads. Also, the Payload Data Interleaver (PDI) is connected to PL data bus 1. Additionally, on some flights there are one or two flex MDMs, which connect the PL data buses to other payload equipment. See Figure 2-10.

Like the FC MDMs, the PL MDMs are each connected to two data buses and, therefore, can be port moded. However, the other equipment on the PL data buses is connected only to one bus and cannot be switched by PL MDM port moding.

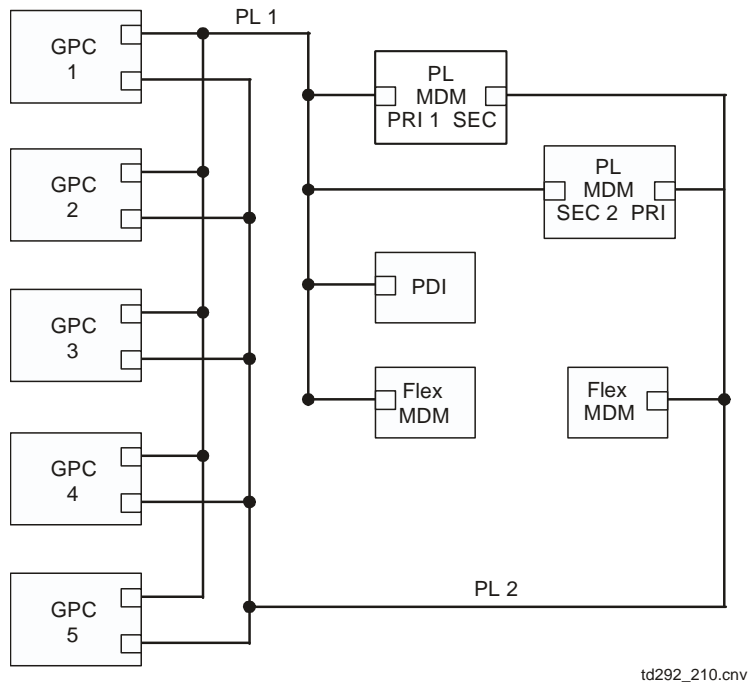

Figure 2-10. Payload data buses

2.2.3 Launch/Boost Data Buses

Two data buses are used primarily for ground checkout and launch phase activities. They are called the Launch Data Buses (LDBs) (sometimes referred to as the Launch/Boost Data Buses). As shown in Figure 2-11, they connect the five GPCs with the Ground Support Equipment (GSE) launch processing subsystem, the LF1, LM1, and LA1 MDMs onboard the orbiter, and the two left and two right SRB MDMs (LL1, LL2, LR1, and LR2).

The interface to the GSE is disconnected at liftoff (T - 0), and the SRB interfaces are disconnected at SRB separation. The orbiter launch MDMs are not used after launch.

There is also a postlaunch function for launch data bus 1. It is connected to the MCIU, which provides the GPCs Input/Output (I/O) with the Remote Manipulator System (RMS). Therefore, that bus is assigned to the SM GPC on orbit.

Finally, as described in Section 3, the launch data buses may be used for GPC-to-GPC memory overlays if necessary.

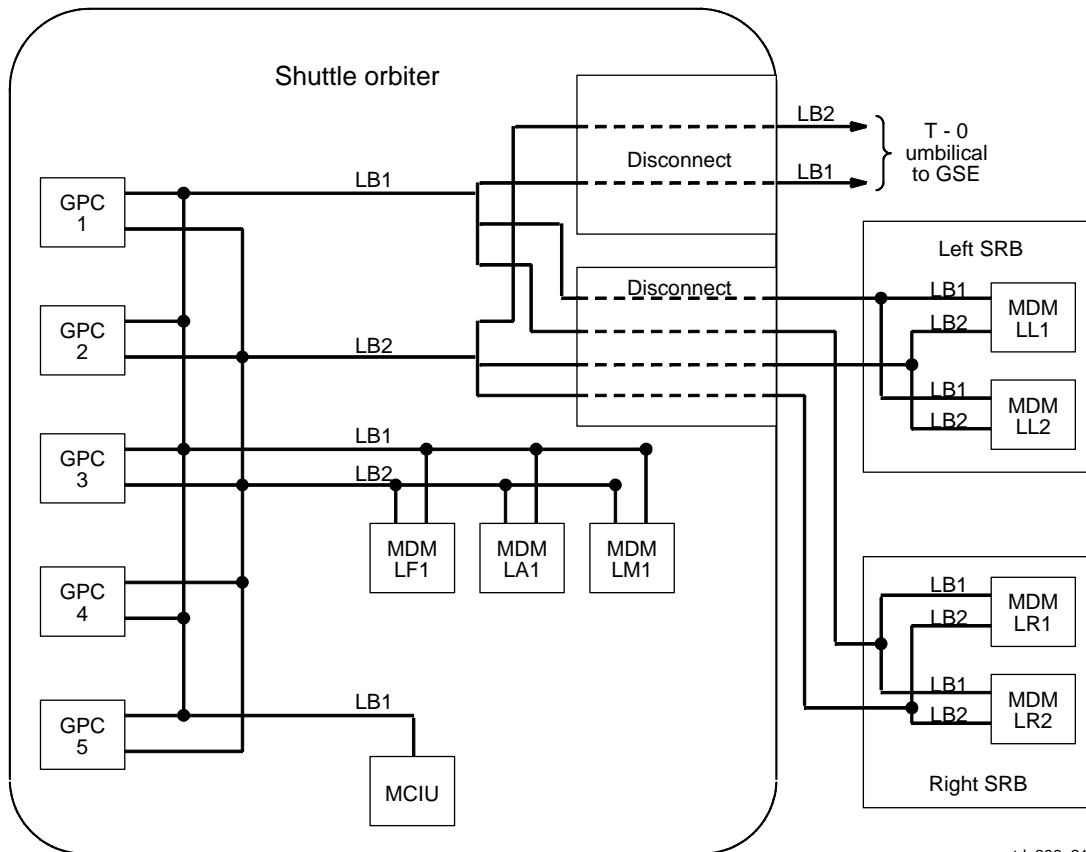

td_292_211

Figure 2-11. Launch data buses

2.2.4 Mass Memory Data Buses

The MM data buses are discussed in detail in the MMU portion of this workbook.

2.2.5 Display/Keyboard Data Buses

The DK data buses are discussed in detail in the MEDS portion of this workbook.

2.2.6 Instrumentation/PCM Master Unit Data Buses

There are five IP data buses onboard the orbiter. Note that these buses are unique in that each GPC commands its own individual data bus to both PCMMUs. For all the other types of data buses, each bus goes to every GPC.

A GPC transmits its downlist data to the active PCMMU via its IP data bus. As required by software, a GPC may receive instrumentation data and PCMMU BITE status by polling the active PCMMU over its IP data bus. When commanded by the crew, a GPC transmits the required downlink telemetry format to the PCMMUs over the IP data bus. During GPC/PCMMU communications over the IP data buses, only one PCMMU is powered (at any one time) to respond to GPC commands. These subjects are covered in detail in the downlist portion of Section 3.

Figure 2-12 illustrates the IP data bus arrangement.

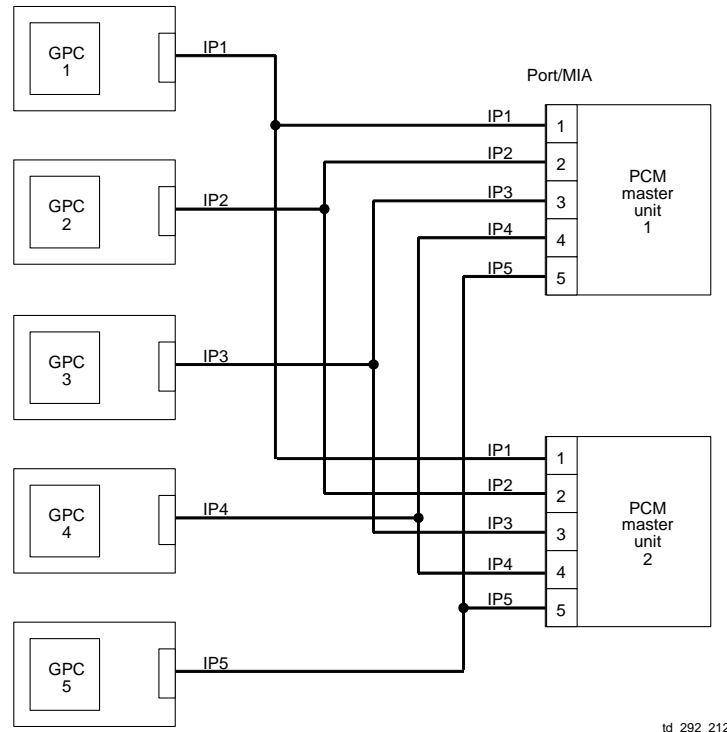
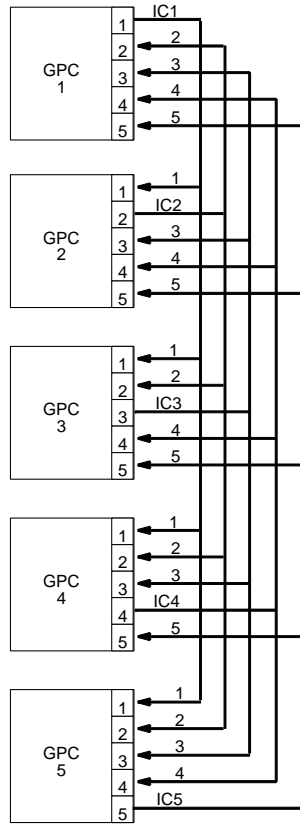

Figure 2-12. IP computer data bus interface

2.2.7 Intercomputer Communication Data Buses

As can be seen in Figure 2-13, there are five ICC data buses on the orbiter. All active PASS GPCs, which are members of the common set, exchange status information over the ICC data buses. During on-orbit operations, the SM GPC will receive GNC data from the GNC GPCs. Note that the GPC that is processing Backup Flight System software (BFS GPC) does not transmit or receive data over the ICC data buses.

Another point to note here is that communication over the ICC data buses is different from the data traffic, which is transmitted over the other types of computer data buses. ICC data bus traffic occurs in one direction only. A GPC transmits over its own ICC bus and receives data from the other GPCs over each of their dedicated ICC buses. The commands and data that are carried on the other types of computer data buses are of the command response type. That is to say, a GPC has to go out and “request” data over a specific data bus before the data is sent from the appropriate hardware device back to the GPC over the same data bus.



td_292_213

Figure 2-13. Intercomputer communication data buses

2.3 MULTIPLEXER/DEMULPLEXER

2.3.1 Description

There are 24 BTUs called MDMs onboard the orbiter (Figure 2-14). Seven of these MDMs are a part of the instrumentation system and send instrumentation data to the PCMMUs. They are called Operational Instrumentation (OI) MDMs. There are four located forward (OF1, OF2, OF3, OF4) and three aft (OA1, OA2, OA3). These MDMs are discussed in the Comm/Instrumentation workbook.

The other MDMs are part of the DPS, and all of them are connected directly to the GPCs. They are named according to their location and hardware interfaces.

- FF MDMs - (1 to 4)
- FA MDMs - (1 to 4)
- PL MDMs - (1, 2)
- Launch-SRB Left (LL) MDMS - (1, 2)
- Launch-SRB Right (LR) MDMs - (1, 2)
- LF MDM - (1)
- LM MDM - (1)
- LA MDM - (1)

There may also be one or two Flex MDMs (FMDMs) connected to the PL data buses, depending on the payload needs for a particular flight.

The DPS MDMs convert and format serial digital GPC commands into separate parallel discrete, serial digital, and analog commands for transfer to various vehicle subsystem hardware. This operation is called demultiplexing. The MDMs multiplex or convert and format the discrete, serial digital, and analog data from vehicle systems into serial digital data for transmission back to the GPCs.

The components of an MDM include two redundant MIAs or ports, which function like the MIAs in a GPC. (Remember that only one port is active at any given time, depending on the port mode status in the GPC software.) Each MIA is part of a redundant channel inside the MDM, which includes a Sequence Control Unit (SCU) and an Analog-to-Digital (A/D) converter. The SCU splits the commands from the GPCs and sends them to the proper Input/Output Modules (IOMs) for transfer to the proper subsystems. (The IOMs are usually simply referred to as "cards.") The SCU also assembles all the inputs from the various IOM cards into a single bit stream to be sent to the GPCs. The A/D converter converts any analog input data to digital form before it goes to the SCU for multiplexing. (Any analog output commands from the GPC are converted from the digital form sent by the GPC into analog form for use by the subsystem hardware by the output IOM that receives that data from the SCU.)

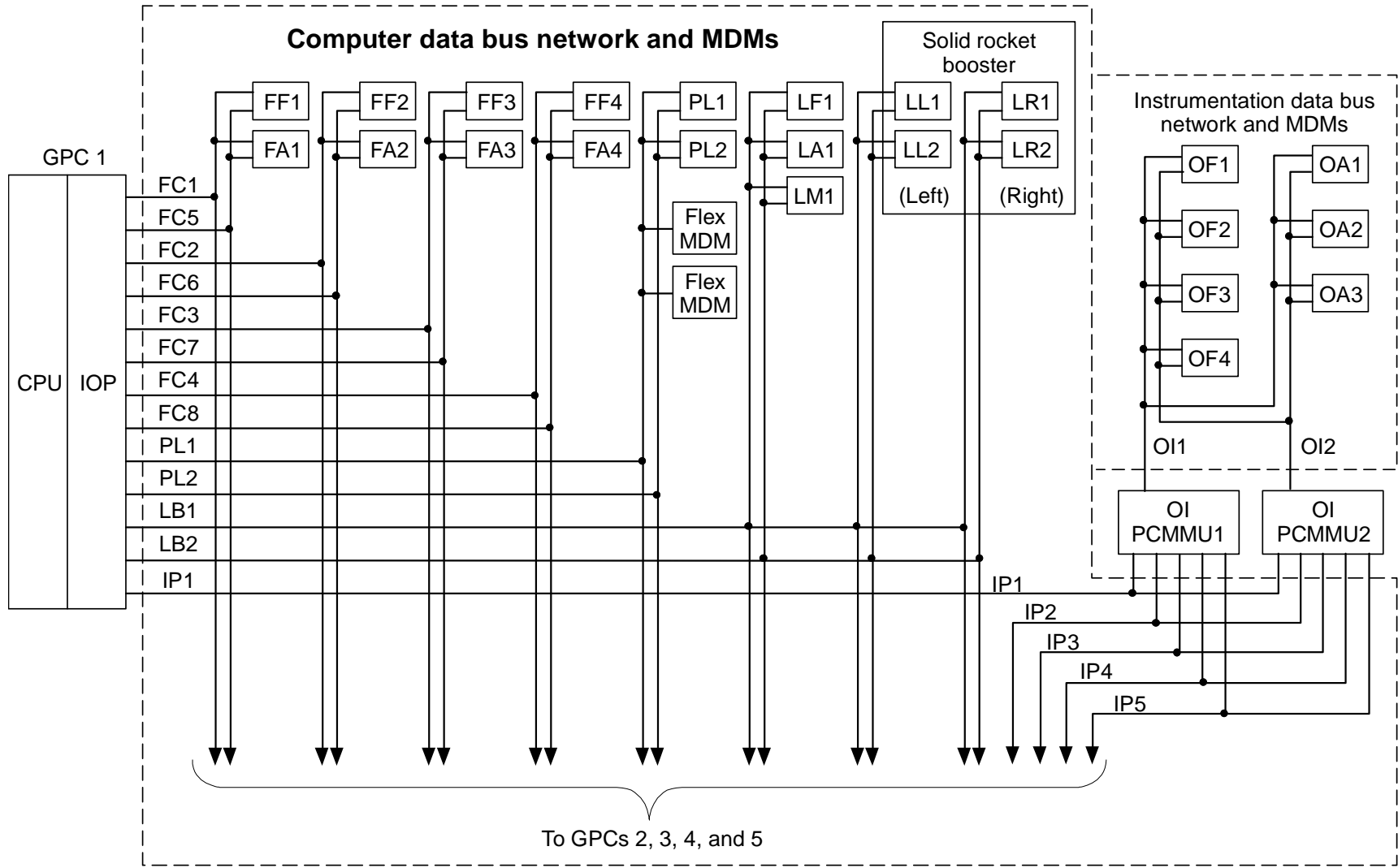

td292_214.cnv

Figure 2-14. Shuttle vehicle MDMs

Which input/output modules (cards) are in an MDM is dependent upon the hardware components accessed by that type of MDM. Therefore, an FC MDM and an SRB MDM, for example, are not interchangeable. However, one FF MDM may be swapped in its slot for another FF MDM or one PL MDM for the other. (This might even be done in flight, if doing so regains access to a critically needed, unfailed piece of orbiter hardware.)

FMDMs are used to interface the GPCs with payload bay pallet systems and experiments. Their function is similar to the other DPS MDMs, except that each FMDM has only one port (vs. the usual two) and is connected to only one PL data bus. FMDMs can be installed in pairs (one connected to each of the two PL data buses) if the payload in question requires the redundancy. In such a case, only one member of the pair is used at any one time. This is controlled in the software via the port mode status.

Figure 2-15 is an MDM functional block diagram.

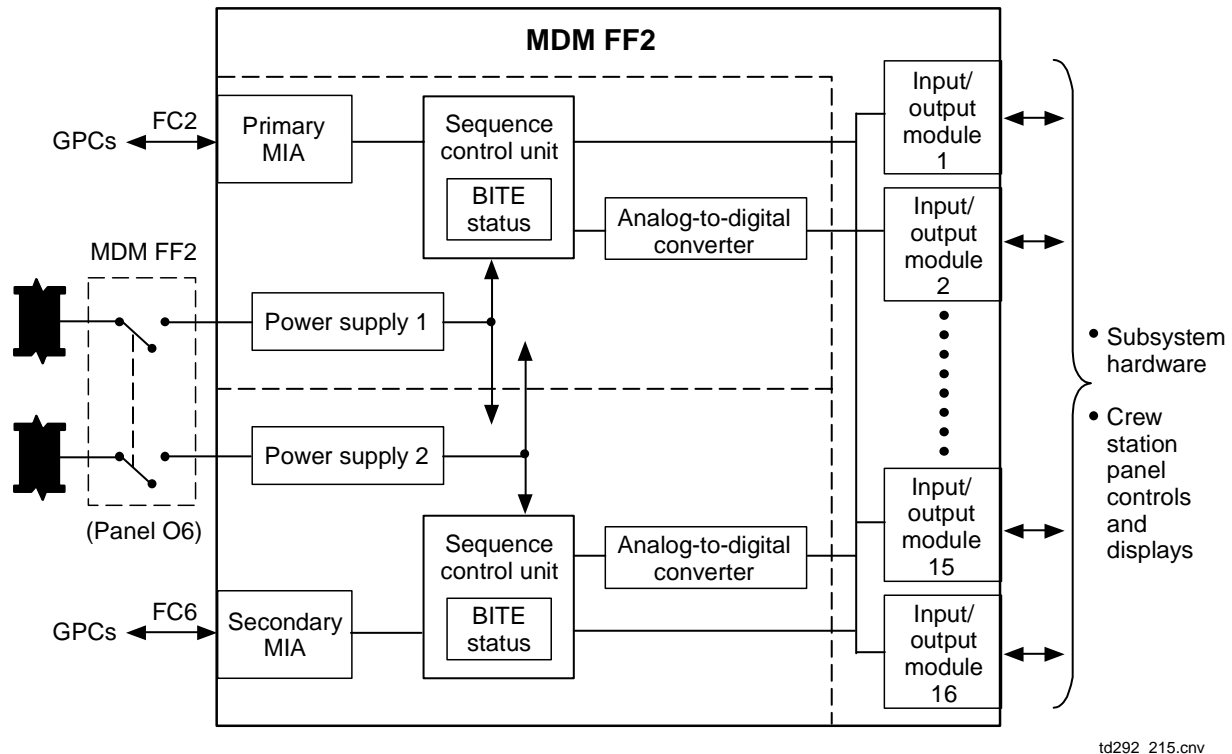

Figure 2-15. MDM functional block diagram

2.3.2 Enhanced MDMs

Since the original shuttle MDMs are getting quite old these days, replacements for them have been acquired. They are called Enhanced MDMs (EMDMs) and are being introduced into the vehicles to replace any failed original MDM, as needed. Although they are called “enhanced,” the EMDMs are virtually indistinguishable by the crew from an original MDM. Their function is identical for nominal vehicle control and data

acquisition. Certain internal failure modes that would have resulted in the annunciation of the MDM OUTPUT fault message for an original MDM will result in the annunciation of an I/O ERROR Fxx fault message for an EMDM.

2.3.3 Interfaces

The MDMs interface with the GPCs via serial digital data buses as previously described. Each MDM (except an FMDM) is connected to two data buses via its MIAs. The arrangement of these buses is pictured in Figure 2-14.

The other functional interface of the MDM is with the appropriate orbiter systems hardware via hardwired lines. The hardware items connected to an MDM are sometimes called Line Replaceable Units (LRUs) (versus something connected directly to a data bus like an MDM or MMU, which is called a BTU). MDMS may also control redundant portions of various units. A list of the major items controlled by each MDM is included in the Reference Data book. An example is shown in Figure 2-16.

FF1				
BCE	GPC INPUT		BCE	GPC INPUT
A	F RCS Ts & Ps MANF 1 P BFS QTY IMU 1 STATUS PNL F6 DISP SWs (eight)		ADTA IMU MLS MTU NSP STKR TAC	ADTA 1 IMU 1 MLS 1 MTU ACCUM 1 NSP 1 -Z S TRK TACAN 1 RADAR ALT 1
			GPC OUTPUT	
B	AA 1		AA TEST	
	F RCS MANF 1 JET RM		ADTA 1 TEST	
	L ADS DEPLOY DISC	- A*	F RCS He PRESS VLV A	
	RMG NO WOW	- 1*	MANF 1 JETS	
	CNTRLs/PBIs/SWs:		IMU 1	
	AFT DAP CNTRL	- 3*	L OMS GMBL PRI SEL	
	RHC	- 1*	MLS 1 TEST	- 1*
	SENSE	- 1*	MTU UPDATE	
	THC	- 1*	NWS 1	
	FCS CH 1 ORIDE	- 2*	RADAR ALT 1 TEST	
	3 ORIDE	- 2*	TACAN 1	
	4 ORIDE	- 3*	-Z S TRK	
	ENTRY MODE	- 1*	DISPLAYS:	
	FWD DAP AXES	- A*	C/W: L RCS (LK/TK P)	
	CNTRL	- 1*	FWD DAP LIGHTS	
	THC	- 1*	L FCS MODE LIGHTS:	
	LATT REF		BDY FLP AUTO	
	BDY FLP	- A*	P & R/Y AUTO	
	FCS MODE	- 1*	SPD BRK AUTO	
	PNL TRIM	- A*	RCS COMMAND LIGHTS	- A*
	RHC	- 1*	FWD, L, R RCS OXID QTY	
	TRIM INH	- A*	FWD, L RCS LOWEST QTY	
	TRIM	- A*	SPI: ELEVON POS	
	RUD PEDAL	- 1*	SPD BRK POS	
	SBTC	- 1*	CMD	
	MAN	- 1*	RUD POS	
	MSTR RCS XFEED	- 1*	OFF FLAG	
	SEP, ET & SRB	- 1*		
	NWS POS FDBK A	- 1*		

* In INPUT & OUTPUT columns, A or B indicates dual redundancy; 1, 2, 3, or 4 indicates triple or quad redundancy

Figure 2-16. Reference data

2.3.4 Controls and Displays

The only hardware controls for the MDMs are the FC and PL MDM power switches on Panel O6 (Figure 2-17), which are to the left of the GPC switches. These are on/off switches that allow power to the four FF, four FA, and two PL MDMs. (The PL3 switch is unwired and is not used.) There are no crew controls for the SRB MDMs, and the flex MDMs are powered via the PALLET SYS switch on the standard switch panel.

There are no hardware displays associated with the MDMs.

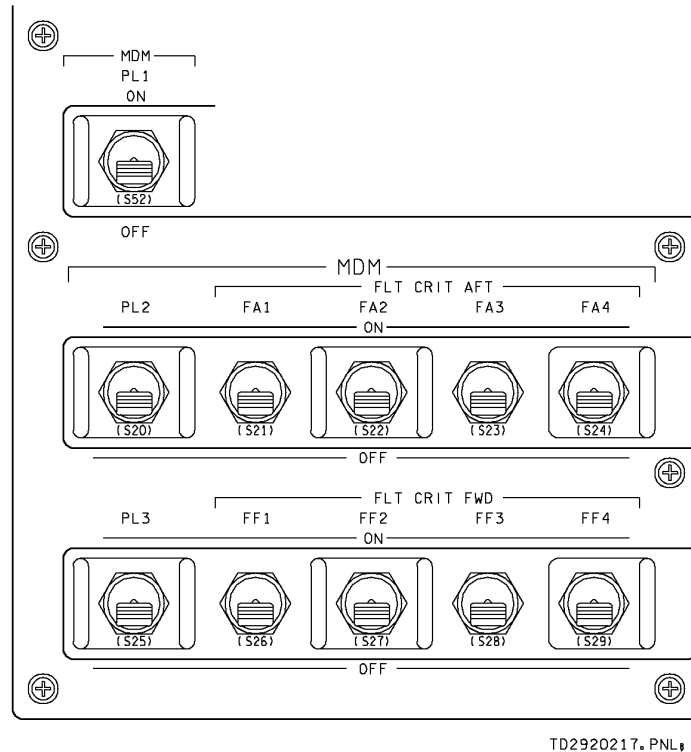

Figure 2-17. MDM controls on Panel O6

2.3.5 Power, Location, and Cooling

The MDMs are each redundantly powered by two main buses. The power switches permit control bus power to activate an RPC from each main bus to an MDM. The main buses power separate power supplies in the MDM, and loss of either main bus or MDM power supply does not cause a loss of function. (Each power supply powers both of the ports in an MDM.) Turning off all power to an MDM causes all the commands out to subsystems to be zeroed. MDMs use between 32 and 80 watts, depending on type.

The SRB MDMs receive power through SRB buses A and B. These buses are tied to the orbiter main buses and controlled by the MEC circuitry. The launch forward and aft MDMs receive their power through the preflight test buses.

The FMDMs use payload electrical bus power and have only one power supply.

The FF, PL, LM1, and LF1 MDMs are located in the forward avionics bays and are cooled by water loop coldplates. LA1 and the FA MDMs are in the aft avionics bays; therefore, they cannot be changed out in flight like the FF and PL MDMs. LA1 and the FA MDMs also have Freon loop coldplate cooling, as do any FMDMs located on the payload bay pallets. There is passive coldplate cooling for the MDMs located in the SRBs (LL1, LL2, LR1, LR2).

2.4 MODULAR MEMORY UNIT

Onboard the orbiter, there are two devices that store the flight software for the GPCs, store the GPC checkpoint data, and store the format loads for the PCMMU and PDI. These are the Solid State Mass Memories (SSMMs), housed in the same BTUs as the Solid State Recorders. The two types of devices share the same physical box, which supplies common power, but are functionally distinct, each having its own data and command interfaces. The terms SSMM and MMU are often used interchangeably, however, especially in flight data file.

In addition to the basic flight software, the MMUs store the background formats and coding for certain CRT displays (which are called “roll-in specs” since they are “rolled-in” from the MMU when needed rather than stored in the GPC software load).

2.4.1 SSMM Description

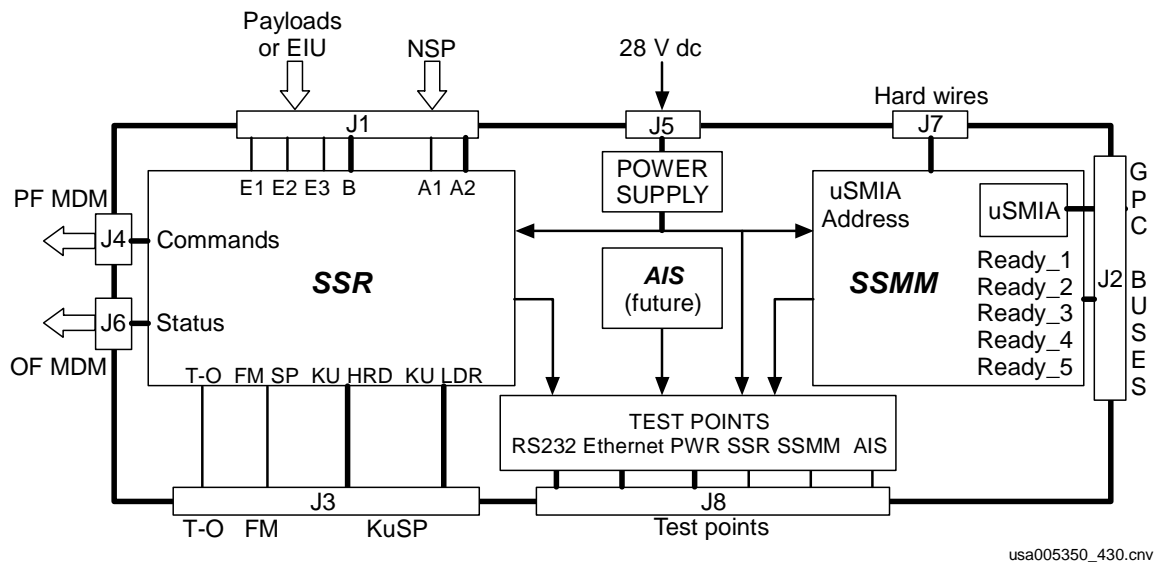
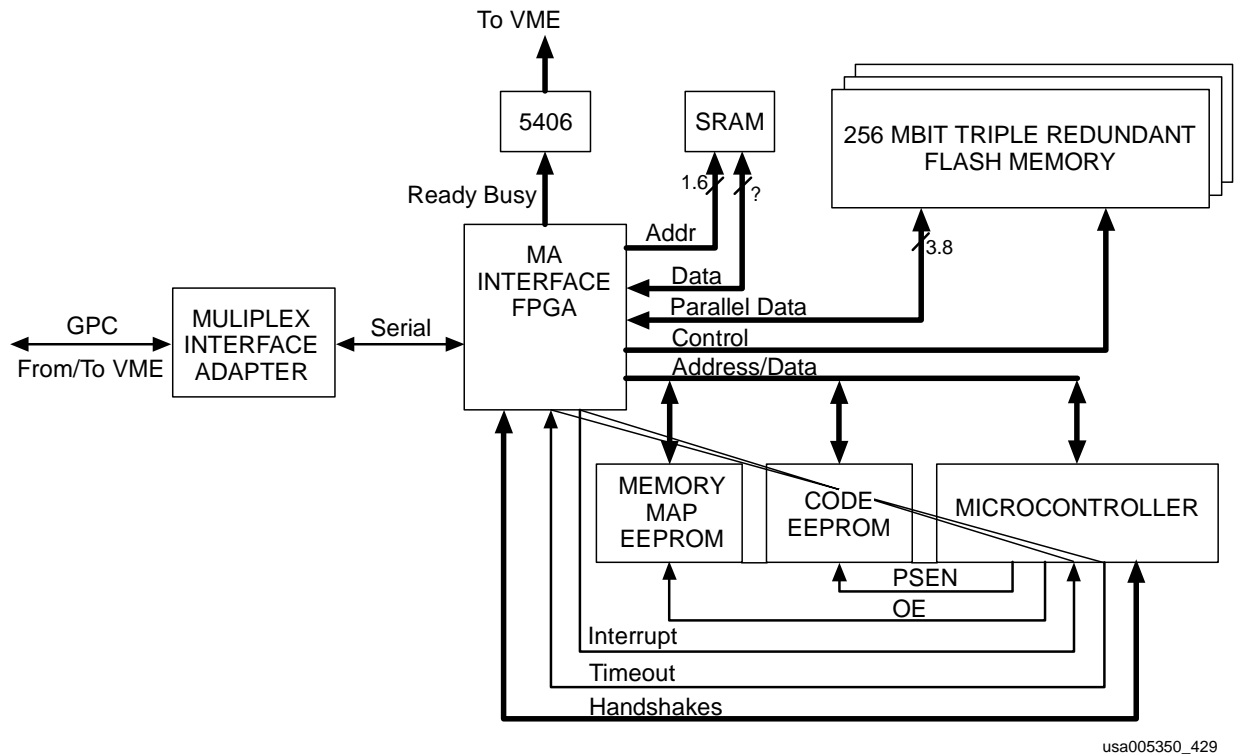

Figure 2-18. Modular Memory Unit functional block diagram

A SSMM duplicates the functions of the old mass memory unit it replaced, with only one major difference—speed. Most crew requests for software or data from the SSMMs (such as checkpoint or roll-in spec retrieval) require only a couple of seconds. OPS transitions require a time comparable to that of expanding the redundant set. This leads to one other significant signature difference in SSMM operations.

The SSMM does not utilize error-correcting code, per se, to protect the software and data that it stores. The memory contents are stored in three storage locations in the flash memory for each bit of data or software. During read back, all three bits are read and a “majority rule” scheme is used to generate the data stream back to the GPC(s). Between the extremely high reliability of flash memory and the “majority rule,” the chances of any data/software errors from SSMM storage are extremely remote.

Further, the SSMMs have three copies of the PASS and two copies of the BFS software, as well as utilize data/software checksums.



usa005350_429

Figure 2-19. SSMM functional block diagram

2.4.2 Interfaces

Each SSMM interfaces with its MM data bus via a MIA which functions just like the ones in the GPCs. Each data bus is connected to all five GPCs (Figure 2-20). The serial digital commands and data from the GPCs and the data read from the MMU are sent on the data bus. (Note that each MMU is connected to only one MM data bus. Thus, MMUs cannot be port moded.)

In addition, each MMU has a separate discrete line that goes to each of the GPCs (one of the GPC's discrete inputs), called the "ready discrete." If the discrete is on, it tells the GPC the MMU is ready for a transaction. When the discrete is not present, the MMU is either busy with another transaction or powered off.

Note that all MMU operations and transmissions to the GPCs are on an on-demand basis only. In other words, there is no insight into the state of the MMU (other than the ready discrete) unless a specific transaction is requested. This includes the status of the MMU Built-In Test Equipment (BITE), which is updated only for an MMU read or write.

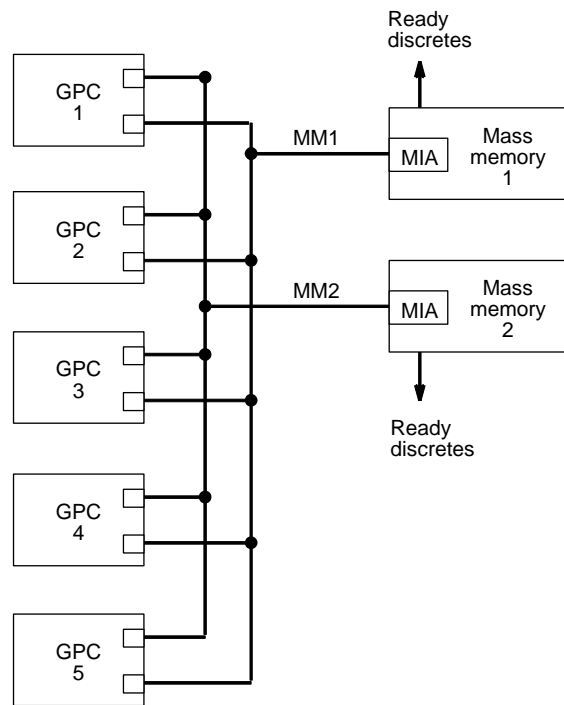

td_292_219

Figure 2-20. MM data buses

2.4.3 Controls and Displays

The only controls for the MMUs or SSMMs that do not go through the GPCs are the MMU power switches. The MMU 1 power switch is on Panel O14, and the MMU 2 power switch is on Panel O15 (Figure 2-22). The associated MMU power switch controls power to the SSMM and the SSR. The two functions cannot be powered on/off independently.

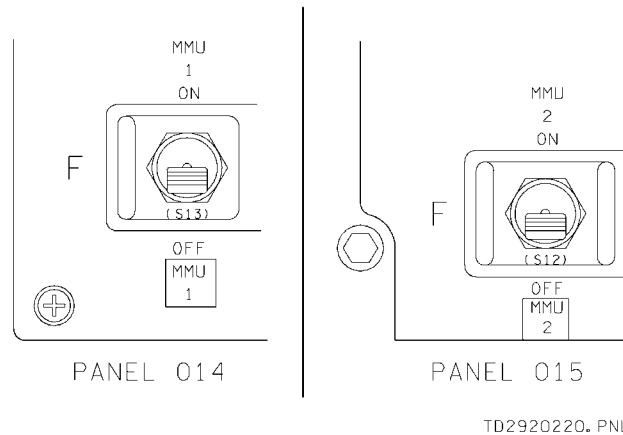

Figure 2-21. MMUs 1 and 2 switches

There are no hardware displays for the MMUs. The ready discrettes are displayed on the SPEC 1 DPS UTILITY display, which will be discussed in Section 3.

2.4.4 Power, Location, and Cooling

Each MMU is powered by one main bus. The power switch allows control bus power to activate an RPC, which in turn allows main bus power to flow to the MMU power supply. MMU 1 is powered by MNA and MMU 2 by MNB. A Modular Memory Unit uses approximately 64 watts.

The MMUs are located in the avionics bays: MMU 1 in AV Bay 1 and MMU 2 in AV Bay 2.

Cooling is provided by water loop coldplates.

2.5 MULTIFUNCTION ELECTRONIC DISPLAY SYSTEM

2.5.1 Description

The Multifunction Electronic display system (MEDS) is a “glass cockpit” integrated display system. The MEDS hardware components consist of four Integrated Data Processors (IDPs), eleven Multifunction Display Units (MDUs) (nine in the forward cockpit and two in the aft), and four Analog-to-Digital Converters (ADCs). MEDS replaced the previous Multifunction Cathode Ray Tube Display System (MCDS) in which four Cathode Ray Tube (CRT) units were used exclusively for DPS displays. Only the Display Driver Units (DDUs) from the old system were retained on these vehicles to continue to supply power for the hand controllers.

The MEDS hardware units are distributed among the three main buses for power. Command of the nine forward MDUs is distributed between IDPs 1 to 3. The aft MDUs are connected to IDP 4 only. The MEDS LRUs were also distributed so that no two failures take out all of the CRT MDUs and no two IDP failures take out all of the Commander (CDR) or Pilot (PLT) MDUs.

The arrangement of the forward MDUs is shown in Figure 2-22.

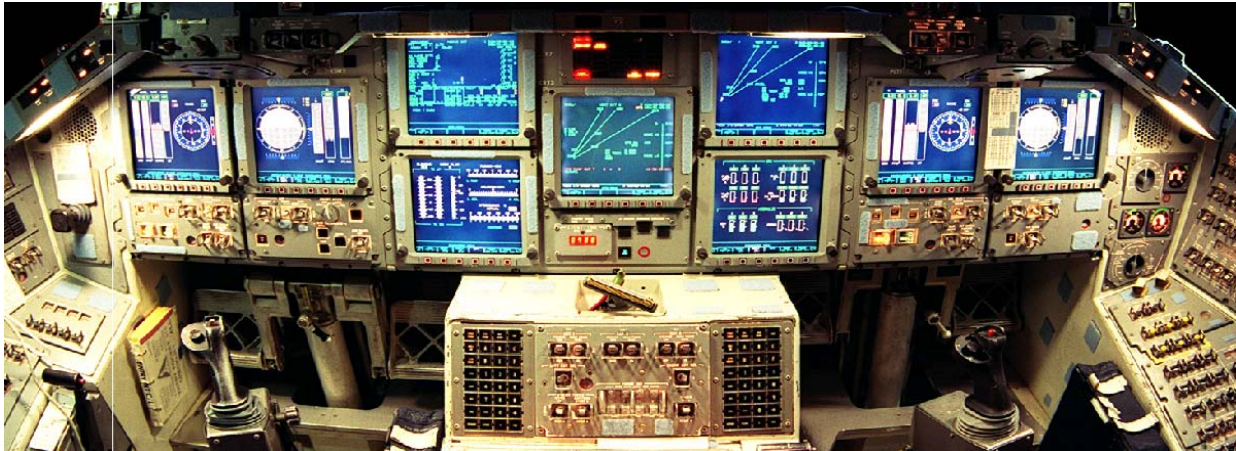

Figure 2-22. Forward MEDS MDUs

The interfaces among the various MEDS LRUs are shown in Figure 2-24.

2.5.1.1 Integrated Display Processors

Each IDP contains an 80386DX processor (16 MHz) and serves as the interface between MEDS and the GPCs. They format data from the GPCs and ADCs for display on the MDUs. Also, they accept operator inputs from switches, edgekeys, and keyboards. In addition to all of these functions, the IDPs also monitor the health of the other MEDS LRUs and of themselves. They have both hardware BITE and software self-tests.

On the GPC side, each IDP is connected to flight-critical data buses 1 to 4 and one Display/Keyboard (DK) bus in addition to the panel switches and the keyboards. Each IDP can display flight instrument and subsystem data on more than one crew station (left, right, aft). On the MEDS side, each IDP controls a 1553B data bus. This 1553B data bus allows the IDP to interface with the MDUs and an ADC.

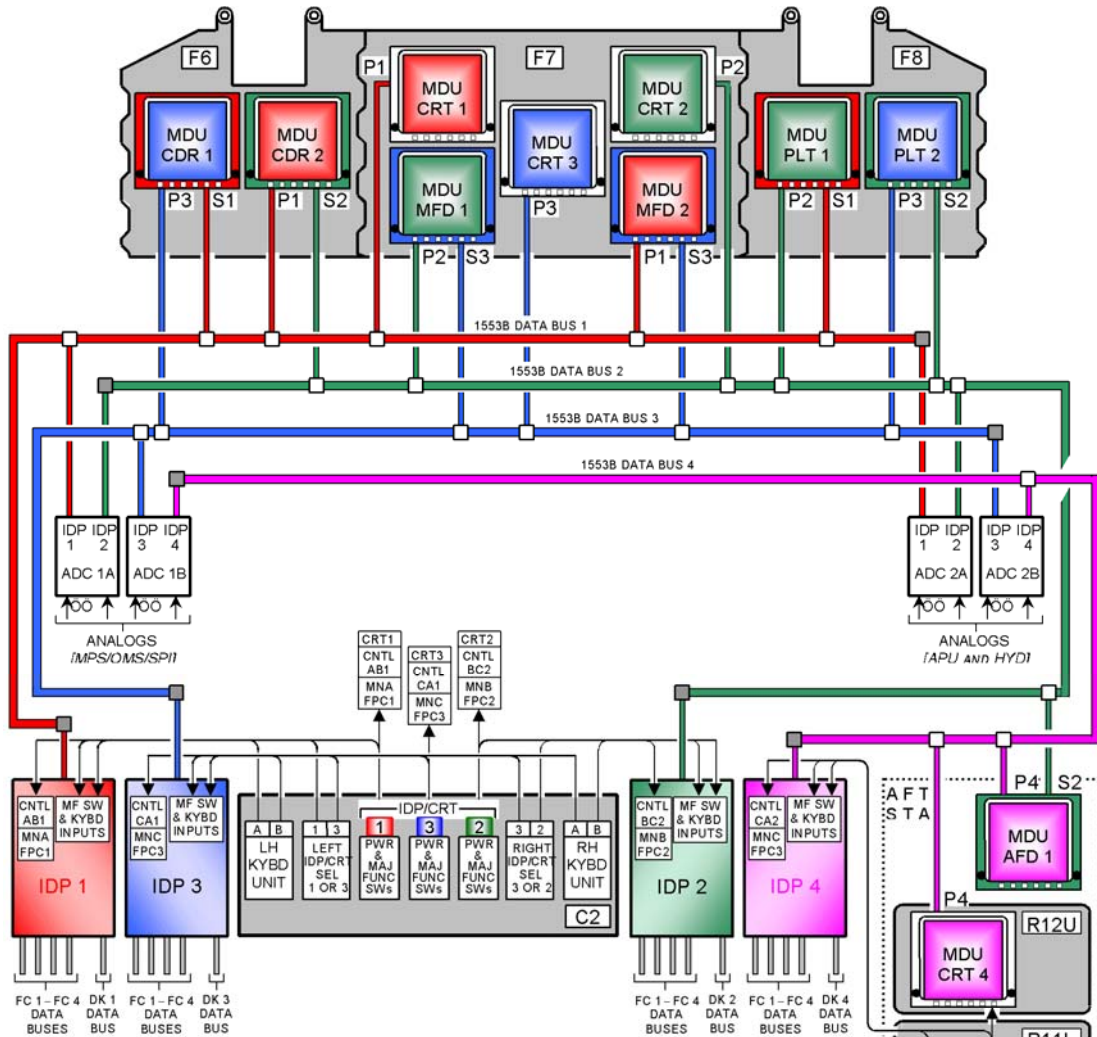

MEDS OVERVIEW
[POWER AND INTERNAL 1553B DATA BUS CONFIGURATION]

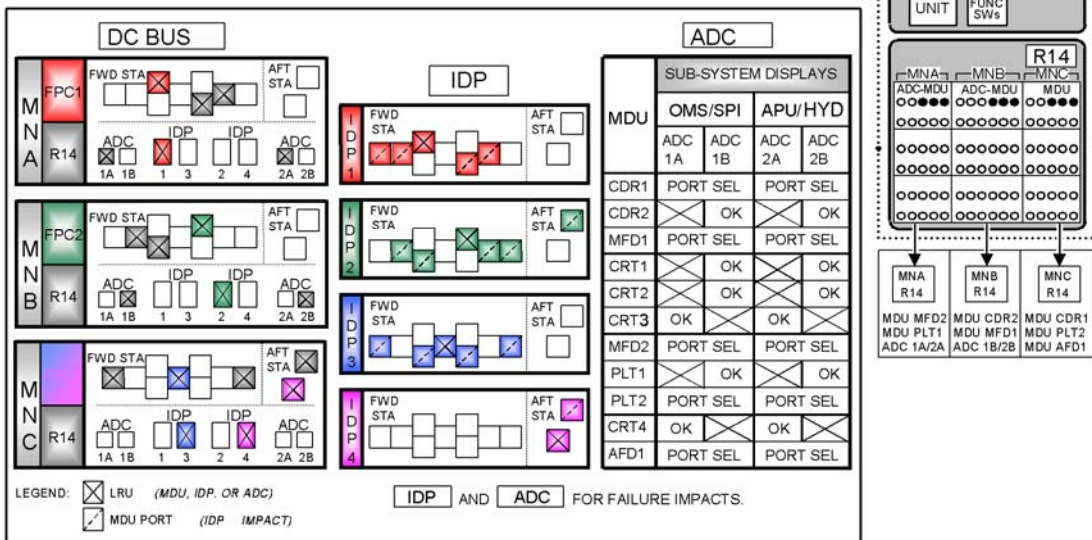

usa005350_001

Figure 2-23. MEDS interface

Each IDP has 2.5 Mbytes of volatile random access memory (RAM) and 1.0 Mbytes of electrically erasable programmable read-only memory (EEPROM). The RAM serves as a temporary storage of critical display formats and executable software. The IDP software will execute out of RAM. The EEPROM serves as a storage location for critical display formats, self-test results, failure information, and the IDP executable programs. Both the RAM and EEPROM are protected by Error Detection and Correction (EDAC). A memory scrubber is also used in conjunction with the EDAC to limit the effects of any radiation-induced single event upset that could occur. Each IDP also contains a Mass Storage Unit (MSU) disk drive for storing copies of the MDU and IDP software and files for error logs. The MSU is a 300-Mbyte magnetic hard disk. Ground Support Equipment (GSE) can access the disk for software updates and retrieval through a connector on the IDP. A functional diagram of an IDP is shown in Figure 2-24.

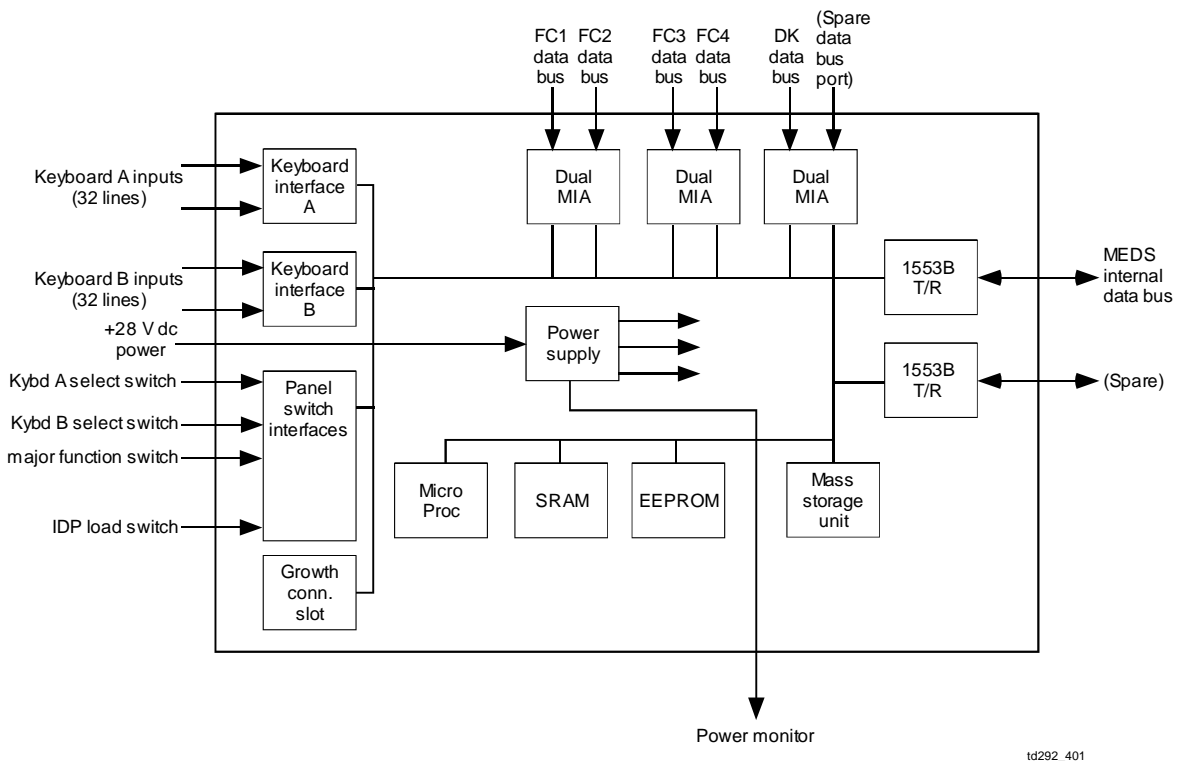

Figure 2-24. Integrated display processor

2.5.2 Power, Location, and Cooling

IDPs require 28 V dc and 42.6 watts, which is supplied by a main bus. IDP1 is powered by MnA/FPC1, IDP2 by MnB/FPC2, and IDP 3 and 4 by MnC/FPC3. The IDP power switches are located on Panels C2 and R12. The power switch is a two-position switch. These switches also power their respective CRT MDUs.

The IDPs are located as shown in Figure 2-25 and are forced air cooled.

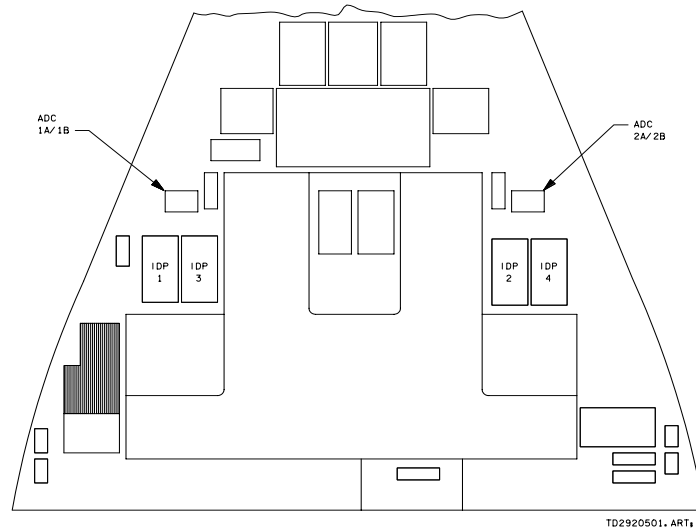

Figure 2-25. IDP and ADC flight deck LRU locations

2.5.3 Multifunction Display Unit

Each MDU contains a R3081 processor (a derivative of the RISC 3000/3010) with a full color, flat panel, 6.7-inch square Active Matrix Liquid Crystal Display (AMLCD). Their graphics coprocessor is a TMS34020 32-bit processor. Their primary function includes driving the variety of MEDS color displays that will be readable even in sunlight.

Like the IDP, the MDU has EDAC and a memory scrubber. It also contains built-in tests to provide protection for failures of the hardware.

Six edgekeys are located below the display on the bezel of the MDU (Figure 2-26). A brightness control knob and an ON/OFF switch are also located on the bezel on either side of the edgekeys. The edgekeys allow user interface with the MEDS (display selection, etc.). The edgekeys are not used for user interaction with the DPS system (i.e., clearing DPS fault messages, item entries, etc.). Even though the edgekeys are located on the MDU, the edgekey commands are handled by the IDP, unless the MDU is in autonomous mode.

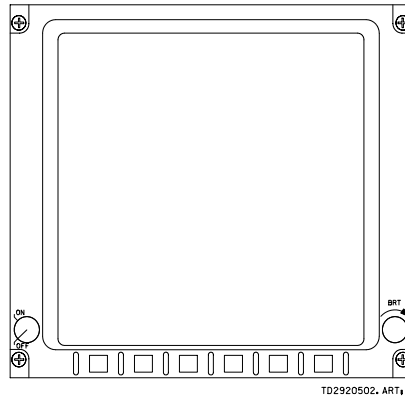

Figure 2-26. Multifunction display unit

In general, each MDU has two ports (primary and secondary) that are connected to two IDPs via a 1553B data bus. Only one IDP commands an MDU at a given time, but both IDPs will monitor the status of the MDU. The exception is the CRT MDUs, which use only their primary port. Their secondary port is not connected to any data bus. Thus, they are connected to a single IDP and, therefore, one DK data bus. Operationally, the CRT MDUs are dedicated to the DPS displays. This configuration maintains the “keyboard/DRT” associations of the MCDS. While in autonomous mode, the MDU continues to run and monitors its two ports for an operating IDP.

2.5.4 Power, Location, and Cooling

The locations of the MDUs on the forward portion of the flight deck can be divided into a left and right group that corresponds to the flight instrument display switches found on Panel F6 (commander’s side) and F8 (pilot’s side). The left side (CDR crew station) consists of CDR 1, CDR 2, MFD 1, CRT 1, and CRT 3. The right side (PLT crew station) consists of CRT 2, PLT 1, PLT 2, and MFD 2. See Figure 2-27 for the layout of the forward flight deck. The aft crew station consists of AFD 1 and CRT 4. CRT 4 is tilted slightly to improve readability.

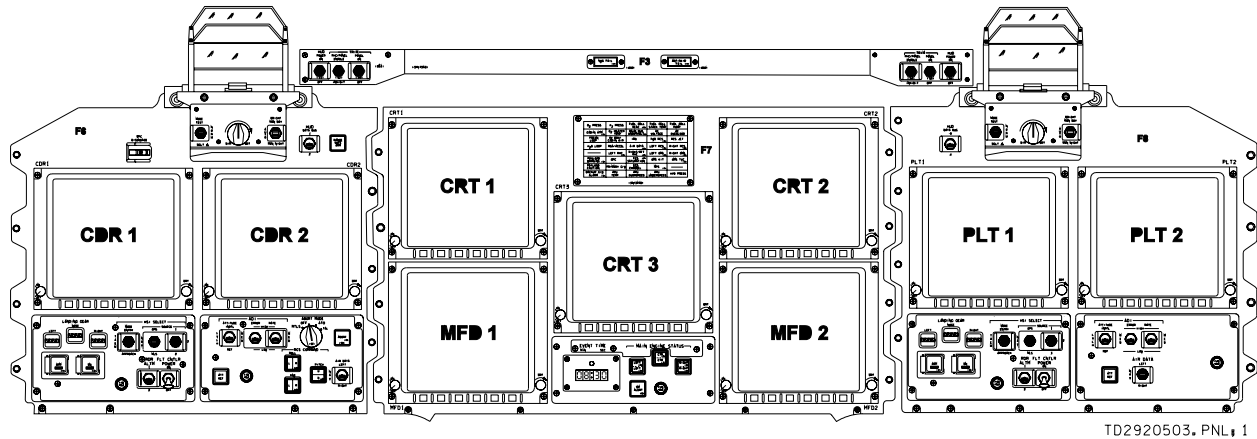

Figure 2-27. MDU configuration

The MDUs are powered via the power knob on the display unit and via a circuit breaker on Panel R14. However, the CRT MDUs do not have a circuit breaker; they are powered by their respective IDP power switch. The MDUs use 28 V dc and 72.2 W. Main A powers MFD 2 and PLT 1. Main B powers CDR 2 and MFD 1. Main C powers CDR 1, PLT 2, and AFD 1.

It is recommended that the MDU bezel switch be turned on after powering up the IDPs, to prevent the MDUs from port moding to another IDP. Also, the MDU should be powered off via the bezel switch before closing the circuit breaker (or the IDP/CRT switch is turned ON) to avoid a potential internal error that prevents it from properly starting up. When powering off equipment, turn off the MDU first and then the IDP to avoid having the MDU swap IDPs.

The MDUs are cooled by forced air cooling.

2.5.4.1 Analog-to-Digital Converter

The ADC converts the Main Propulsion System (MPS), hydraulics (HYD), Auxiliary Power Unit (APU), Orbital Maneuvering System (OMS), and Surface Position Indicator (SPI) subsystem data into 12-bit digital data for use by the IDP in generation of the displays on the MDUs. MEDS includes four ADC units (1A, 1B, 2A, and 2B). ADCs 1A and 1B both convert the analog signals for the MPS, OMS, and SPI meters. ADCs 2A and 2B both convert the analog signals for the APU and HYD meters.

The ADC has the ability to sample 32 input channels at a rate of 25 Hz. It converts them into 12-bit digital data and transmits it to the associated IDP, when requested. The ADC has a double buffer so that it can write new data while old data is being read. Each ADC's software performs a self-test continuously. A functional diagram of an ADC is shown in Figure 2-28.

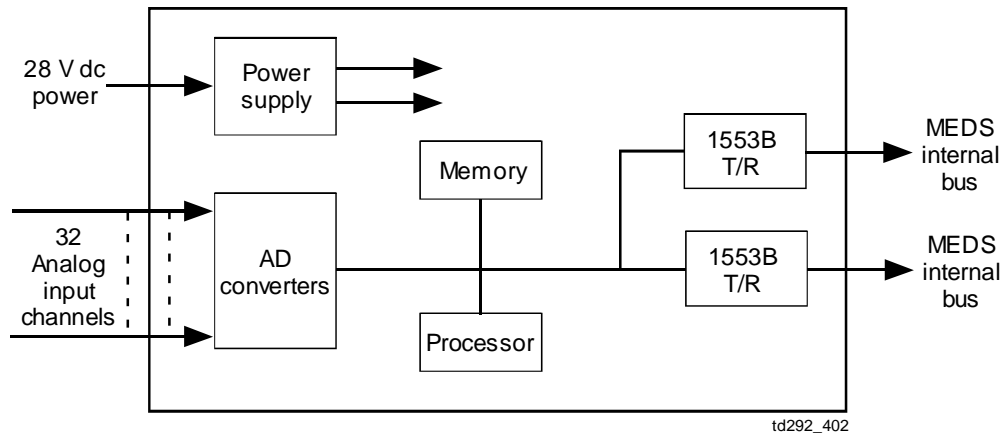

Figure 2-28. Analog-to-digital converter

2.5.5 Power, Location, and Cooling

ADCs are powered by 28 V dc and use 4.5 W. ADC 1A and 2A are powered by Main A via a single circuit breaker on Panel R14, while 1B and 2B are powered by Main B via a single circuit breaker on Panel R14. The ADCs are located as shown in Figure 2-25. ADC In-Flight Maintenance (IFM) capability is not available because access to the ADC mounting area is limited.

The ADCs are passively cooled and do not required forced air or a cold plate.

2.5.5.1 Keyboard Units

Figure 2-29 illustrates an orbiter keyboard unit. The two forward keyboards communicate with IDPs 1 to 3, while the aft keyboard communicates with IDP 4 only.

As shown in the figure, there are 10 number keys, 6 letter keys (used for hexadecimal data inputs), 2 algebraic sign keys, a decimal key, and 13 special-function keys.

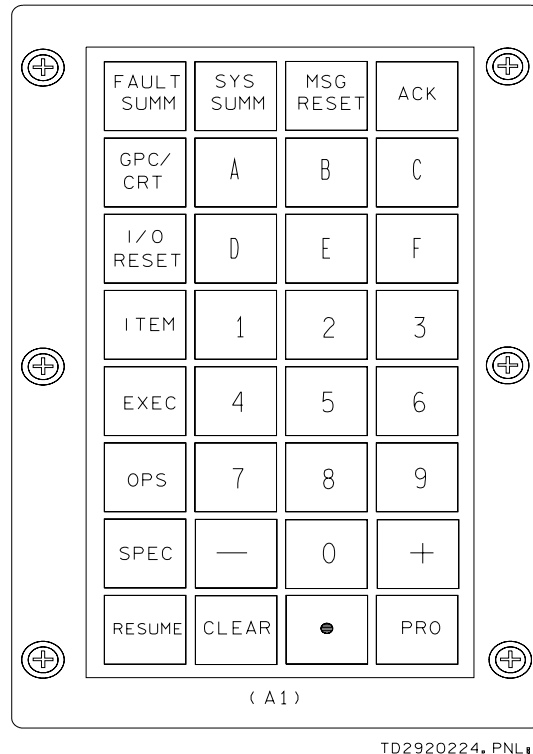

Figure 2-29. Keyboard

Each keyboard consists of 32 momentary double contact pb keys. Each key utilizes its double contacts for communicating on separate signal paths to two IDPs (only one set of contacts on the aft station keyboard keys is actually wired because this keyboard can only communicate with one IDP (see Figure 2-30)).

2.5.6 Interfaces

The IDPs are connected to DK data buses (and thus to the GPCs) via MIAs that function just like the GPC MIAs. All IDPs have two keyboard adapters, but only IDP 3 is connected to two keyboards (see Figure 2-31). The IDP/CRT SEL switches tell the IDPs which adapters to read. (If both keyboards are assigned to IDP 3, then IDP 3 will accept keystrokes from both.) A GPC requests status data and keyboard inputs twice a second from an IDP (i.e., the GPC “polls” the IDP). Besides BITE and keyboard inputs, the IDP also sends the major function switch setting. The GPC sends data to the IDP, as required.

Of course, the whole purpose of the MEDS is to interface with the crew. Crew inputs are made via the keyboards, and data is output from the GPCs via the DPS displays on the MDUs.

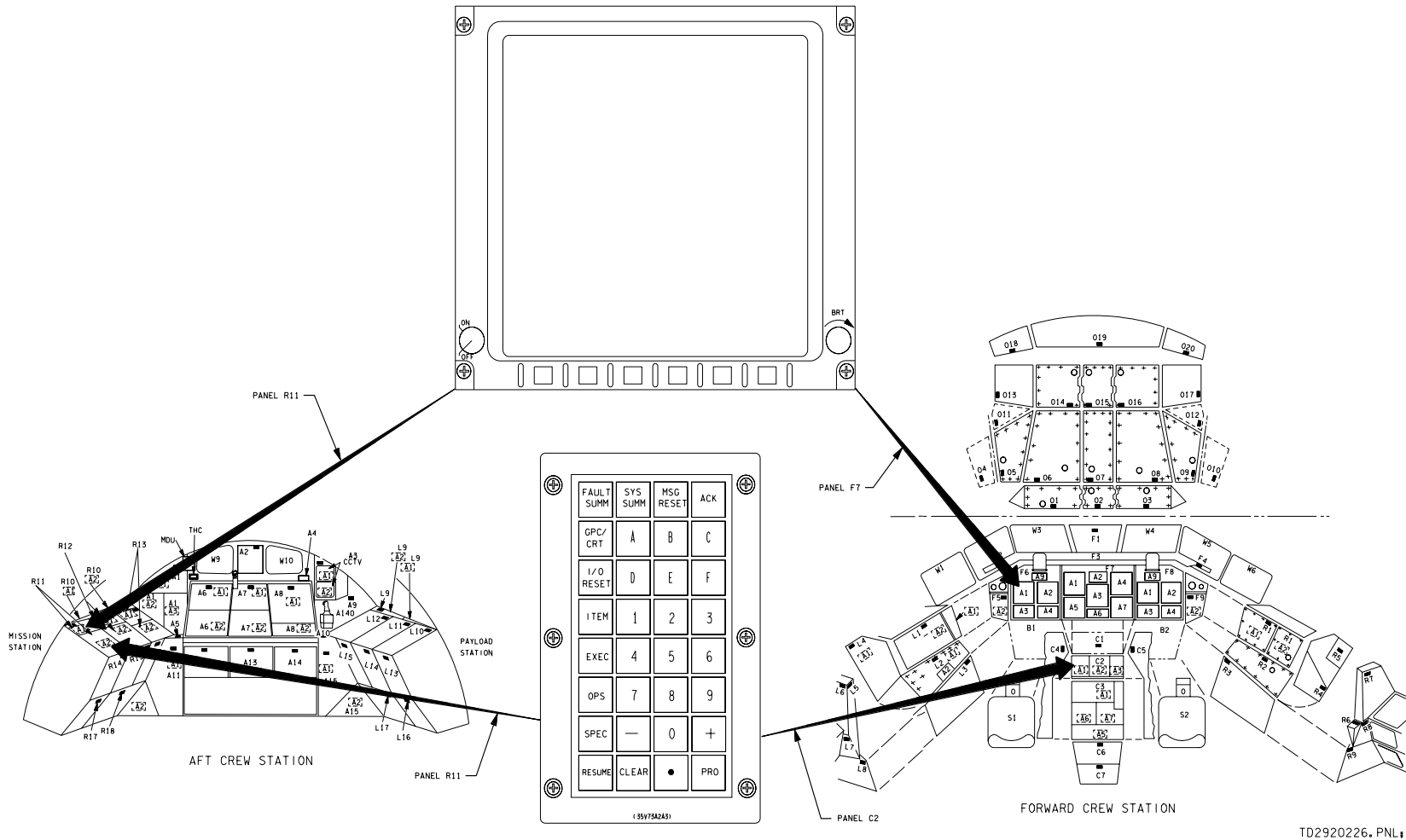

TD2920226, PNL 2

Figure 2-30. DPS keyboard and MDU locations

2.5.7 Controls and Displays

The remaining crew station controls for the MEDS are pictured on the following pages.

2.5.7.1 IDP/CRT SELECT Switches

Recall that there are three IDPs controlling the MDUs in the forward station and only two keyboard units. The forward station keyboard units are each connected to two of these IDPs. The function of the IDP/CRT SEL switches is to identify to the system which IDP is to process keystrokes from each of the keyboards. The left IDP/CRT SEL switch allows the left keyboard to talk to either IDP 1 or 3, and the right IDP/CRT SEL switch allows the right keyboard to talk to either IDP 2 or IDP 3. (Note that both keyboards can be selected to IDP 3 at the same time.) There is no select switch for IDP 4.

2.5.7.2 IDP/CRT POWER Switches

Each IDP has a POWER switch associated with it. Each of these is a two-position switch that permits control bus power to activate remote power controllers, allowing main bus power to flow to the designated IDP and its associated CRT MDU.

2.5.8 Major Function Switches

Depending on the phase of the shuttle mission, there may be different functional groups of software being processed at the same time. These three-position toggle switches (one for each IDP) tell the GPCs which of these software groups is meant to process the keyboard inputs and drive the data presented on the DPS displays for that IDP. More information on major functions is presented in the software section of this workbook.

2.5.9 IDP Load Switch

The IDP load switch (see Figure 2-31) located on Panel O6 is used to load the critical format information for the DPS displays. When the IDP load switch is toggled and a GPC is running an OPS/mode that supports the load (SM OPS 2 or 4, PL OPS 9, or post-IPL OPS 0), the IDP receives the GPC "IDP Load" information and stores only the critical format information in the EEPROM. The IDP uses this copy each time that it is powered on. Nominally, the only time the IDP needs to be loaded with critical formats is after an OI flight software change has occurred in GPC flight software. The IDP also needs to have the critical formats reloaded if it has had a CHECKSUM FAIL error against its EEPROM.

Inadvertent IDP loads via a PASS GNC GPC disable the DPS display for a given IDP with the message "VM LOAD IN PROGRESS." Power cycling the IDP or completing a valid IDP LOAD (via PASS SM or BFS) recovers the DPS display. Critical formats are not lost after an inadvertent BFS IDP LOAD, since the BFS does not overwrite the current critical formats in the IDP.

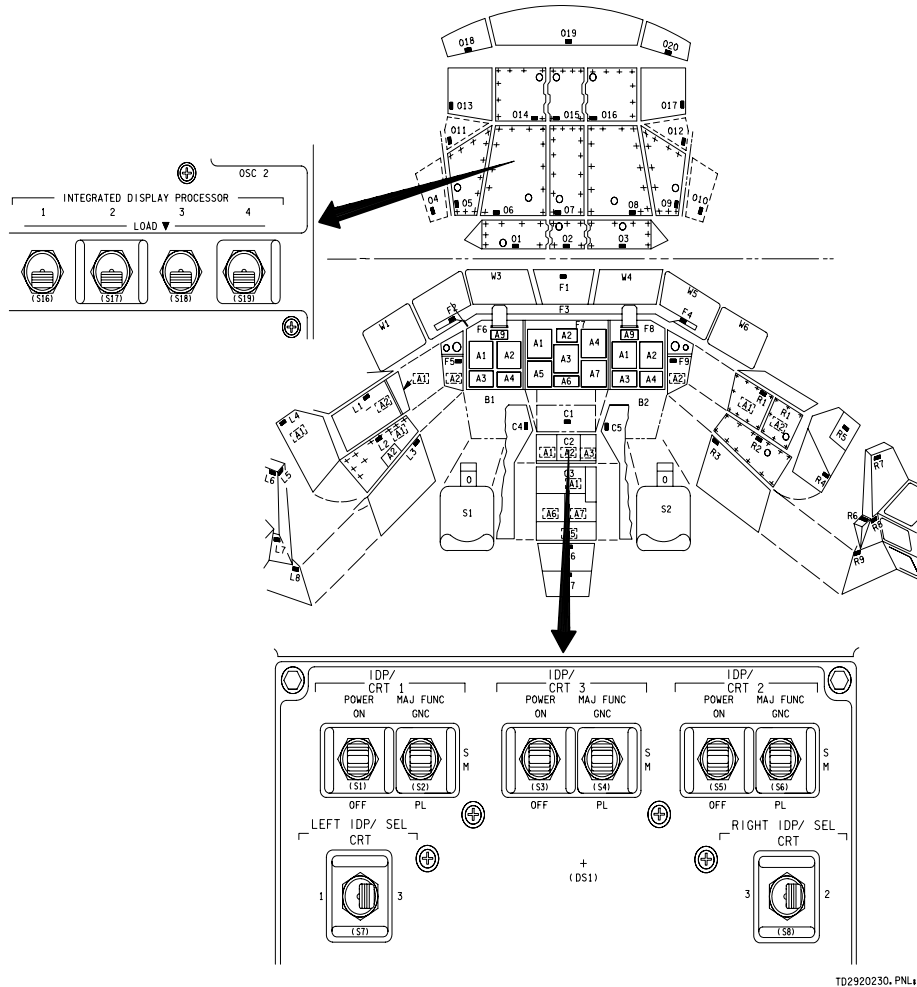

Figure 2-31. IDP controls (forward station)

2.6 MASTER TIMING UNIT

2.6.1 Description

The GPC complex requires a stable, accurate time source because the software within the GPCs uses GMT for scheduling its processing. Each of the five GPCs uses the MTU to update its internal clock because the MTU provides the most accurate timing source. The MTU, which provides precise frequency outputs for various timing and synchronization purposes to the GPC complex and many orbiter subsystems, includes three time accumulators. Each of these MTU accumulators provides both GMT and MET, which can be updated by external control.

The MTU is a stable, crystal-controlled frequency source. The MTU uses two oscillators as redundant frequency sources. The signals from one of these sources (selectable via the master timing unit OSCILLATOR SELECT switch on Panel O6) are passed through signal “shapers” and frequency drivers to the three GMT/MET accumulators. These accumulators keep track of time in days, hours, minutes, seconds, and milliseconds (up to 1 year).

The MTU outputs serial digital time data (GMT/MET) on demand to the GPCs (via the accumulators), which use this time for a computer reference time and indirectly for timetagging of GNC and SM processing. The MTU also provides continuous timing signals to drive the four digital timers in the crew compartment. (There are two mission timers and two event timers.)

2.6.2 Interfaces

The MTU is not a BTU since it is not connected directly to the GPCs via a data bus. Each of the MTU accumulators is tied to a flight critical forward MDM (accumulator 1 to MDM FF1, etc.), as seen in Figure 2-32. Because of this arrangement, any one of the GPCs, which is at least “listening,” on strings 1, 2, or 3 receives MTU time and BITE status. Also, it is obvious that the redundant set GPCs receive the MTU timing inputs simultaneously, thereby allowing them to keep their timing and processing within the limits required for redundant set operations. It should also be noted that each GPC receives timing inputs from each of the three MTU accumulators, but only one is selected as prime. Nonredundant set GPCs receive their time information from the redundant set GPCs via an ICC bus transaction.

The software Time Management Processor (TMP), which is a part of each PASS GPC’s system software, provides external control over the MTU through synchronizing and/or updating the MTU accumulators, as well as requesting the current time and BITE status from the MTU. The TMP is also responsible for comparing the internal GPC time with the MTU time sources, selecting a source, and updating its internal clock, as necessary. The PASS GPCs do not use the MET they receive from the MTU. Instead, they compute MET based upon current GMT and liftoff time. (The BFS GPC does use the MTU MET in OPS 3.)

The system level spec (SPEC 2, called TIME) provides the capability to the user to observe the current MTU and GPC clock status, synchronize or update the MTU and GPC clocks, select MET or GMT as the CRT mission time, and set CRT timers and alert tone duration/timers. SPEC 2 is discussed in the software section.

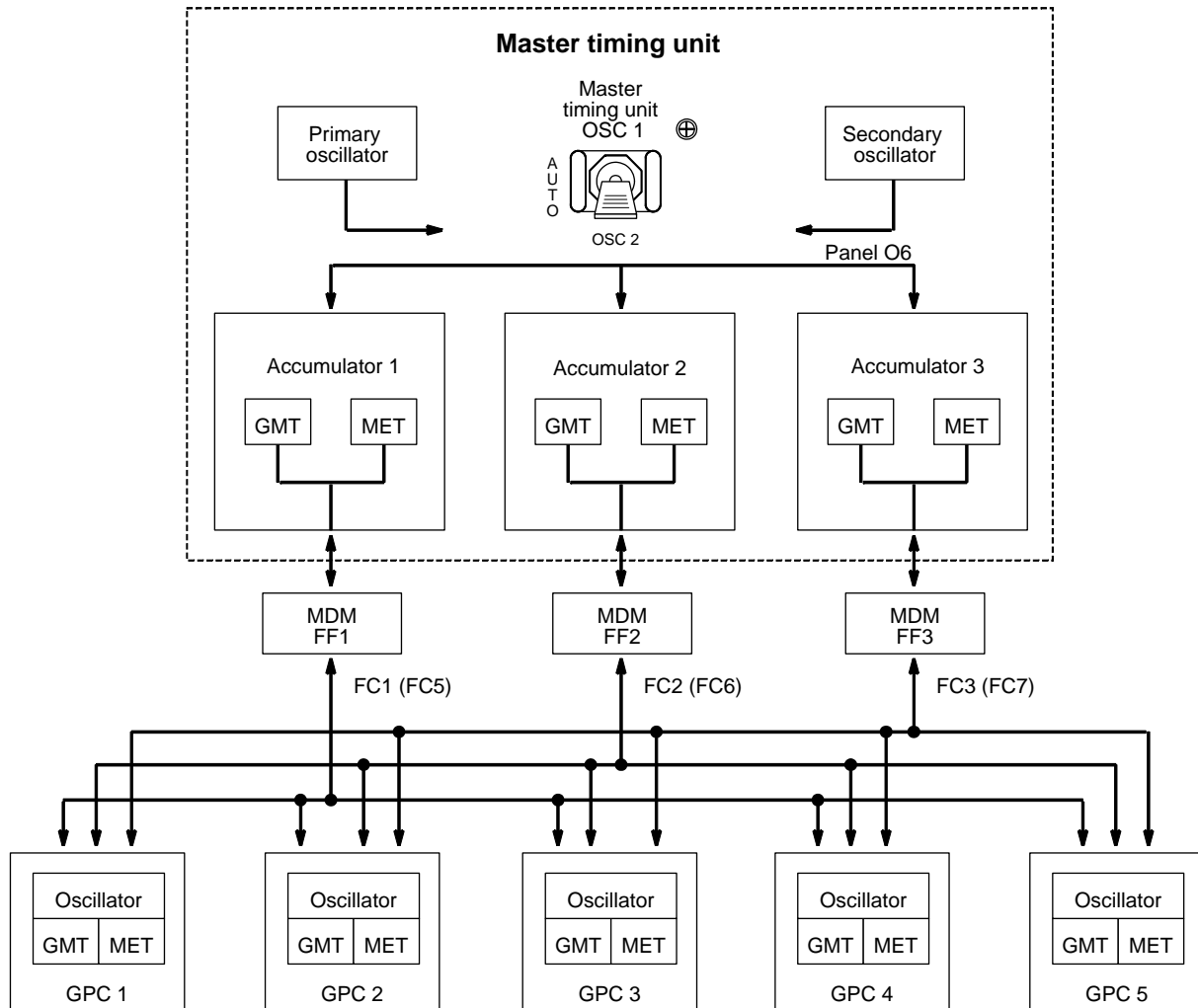

td_292_228

Figure 2-32. GPC/MTU operational interface

Besides sending timing signals to the GPCs and crew station timers, the MTU also provides timing signals to the PCMMUs, the Payload Signal Processors (PSPs), the Communications Security (COMSEC), and the Frequency Modulation (FM) signal processor, as well as various payloads.

2.6.3 Controls and Displays

The MTU is redundantly powered by two cb's on Panel O13: MTU A and MTU B. The only other MTU hardware control is the MTU oscillator select switch on Panel O6 (see Figure 2-32). It is a three-position switch, which selects oscillator 1 or 2 manually in those positions and allows automatic switchover in the AUTO position. If the timing signal from the current oscillator is out of tolerance, the MTU switches to the other oscillator. Normally, the MTU is selected to AUTO for flight.

The only hardware displays associated with the MTU are the mission and event timers (Figure 2-33). The mission timers can display either GMT or MET (via a switch) and are on Panels O3 and A4. The forward event timer is on Panel F7, with controls for setting it on C2. The aft timer is on A4 with controls on A6.

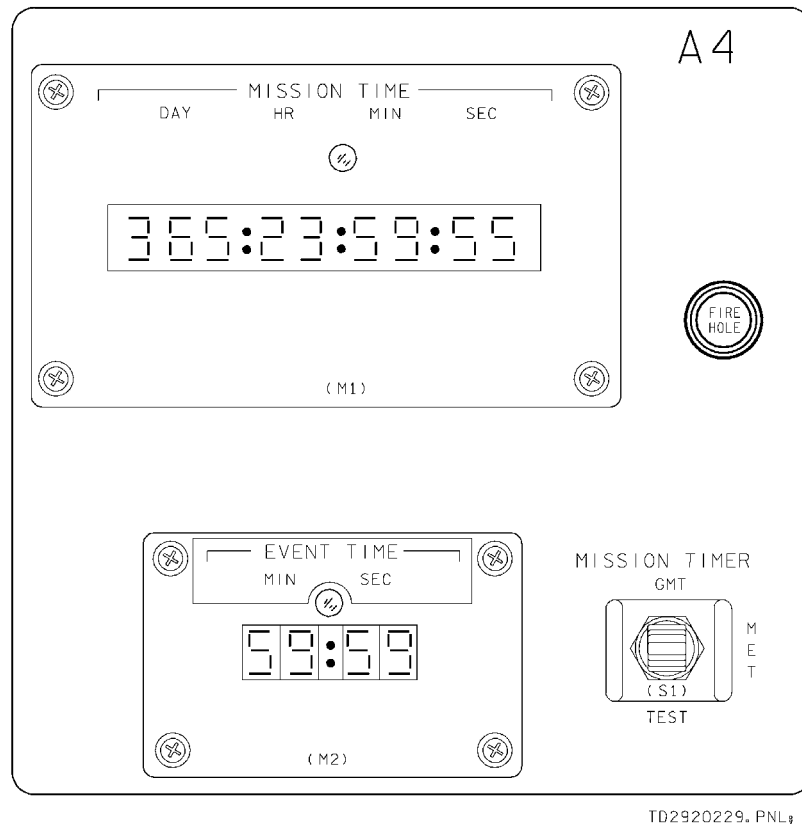

Figure 2-33. Timers

2.6.4 Power, Location, and Cooling

The MTU is redundantly powered by two essential buses. ESS 1BC goes through the MTU A circuit breaker on Panel O13 to one MTU power supply. ESS 2CA goes through MTU B circuit breaker to the other power supply. The nominal power consumption of the MTU is 31 W.

The MTU is located in forward avionics bay 3B. It is cooled by a water loop coldplate.

3.0 PRIMARY AVIONICS SOFTWARE SYSTEM

The principal software used to operate the vehicle during a mission is called the PASS. This primary flight software contains all the programming needed to fly the vehicle through all phases and manage all vehicle and payload systems during orbit.

Since the ascent and entry phases of flight are so critical, four of the five GPCs are loaded with the same PASS software and perform all GNC functions simultaneously and redundantly. As a further safety measure, the fifth GPC contains a different set of software, programmed by a different company, which is designed to take over control of the vehicle should there be a generic error in the PASS software or other multiple errors causing a loss of vehicle control. This software is called the BFS.

In the less dynamic phase of orbit, the BFS is not required, so different portions of the PASS software are loaded into the four GPCs to perform the various tasks during orbit.

This section of the workbook describes how the PASS software relates to the DPS and the crew as presented from an operational viewpoint. BFS differences are presented in Section 4. Flight Data File (FDF) procedures (nominal and off-nominal) are presented when appropriate, as are applicable displays and controls. Functional level descriptions of the software are not included if transparent to the crew. (There are no flowcharts.)

3.1 CONCEPT AND DEFINITIONS

3.1.1 Flight Computer Software

In order for a GPC to perform its required functions, it must be loaded with the proper computer programming or software. Since there are different phases of flight (ascent, orbit, entry) and each phase has many different functions performed, all the software necessary to operate a flight will not fit into a GPC at one time. Therefore, it is divided up into separate sets of software and stored on the mass memory units.

All the software resident in a PASS GPC at any one time constitutes a Memory Configuration (MC). That software consists of two major groups: systems software and applications software.

3.1.1.1 System Software

The system software is the operating system for the GPCs. It controls the interfaces among the GPCs and with the rest of the data processing system. It is loaded into the GPC when it is first initialized and is always resident in GPC main memory; therefore, it is common to all MCs. The system software controls the input and output for the GPCs, performs the loading of new memory configurations, timekeeps, monitors the discretes into the GPCs, and performs the many other different "housekeeping" functions required for the DPS to operate.

It is the services of this software that are described in this section of the workbook. (Note that "system" software has nothing to do with orbiter systems or SM software.)

3.1.1.2 Applications Software

The other group of software that is resident in a GPC is the applications software. It is the applications software that performs the actual duties required to fly and operate the vehicle. In order to conserve main memory, these duties are divided into three applications software groups called major functions: the GNC major function, the SM major function, and the PL major function. Each GPC operates with only one major function at a time (but frequently more than one GPC is in the GNC major function simultaneously for redundancy).

The major functions are subdivided into mission-phase-oriented blocks called Operational Sequences (OPS). Each OPS of a major function is associated with a particular memory configuration, which is loaded separately into the GPC from the MMU. Therefore, all the software resident in a GPC at any one time consists of the system software and an OPS of a major function; i.e., one memory configuration. Except for MC 1, each MC contains one OPS. MC 1 is loaded for GNC at launch and contains both OPS 1 (ascent) and OPS 6 Return To Launch Site (RTL) because there would not be time to load in new software if an RTL became necessary. The transition from one MC to another is called an OPS transition, in which the crew requests a new set of applications software to be loaded in from the MMU. (Every OPS transition must be initiated by the crew.)

Each OPS is further subdivided into software blocks, called major modes, that relate to specific portions of a mission phase. As part of one MC, all major modes of an OPS are resident in GPC main memory at the same time. The transition from one major mode to another can be automatic (e.g., in GNC OPS 1 from precount MM 101 to first stage MM 102 at liftoff) or manual (e.g., in SM OPS 2 from on-orbit systems monitoring in MM 201 to payload bay door operation in MM 202 and back). Each major mode has an associated CRT display called an OPS display, which gives information about that phase and allows crew interaction.

Figure 3-1 is a chart of the orbiter flight computer software.

3.1.2 Displays

There are three levels of displays that can be used by the flight crew to observe systems data and for control of systems via keyboard entries. As just stated, there is a display called an OPS display associated with each OPS/major mode. The OPS displays are the highest priority of the three levels. There are portions of each OPS display that can be manipulated by flight crew keyboard input (or ground uplink) via item entries, which are used to view and modify systems parameters and allow for data entry. See Figure 3-2.

The next level of displays is that associated with blocks of software called specialist functions. These are the spec displays and are invoked by a SPEC XYZ PRO keyboard entry. A spec display "overlays" the current OPS display and is used also to view and modify parameters via keyboard item entries. Depression of the RESUME key terminates the spec, and the overlaid OPS display reappears. There are three special

specs, called systems-level specs. Two of these specs (GPC MEMORY and DPS UTILITY) are available in all memory configurations. The other (TIME) is available in all memory configurations except MC1 and MC3 (GNC OPS 1, 3, and 6). We concentrate on these specs in the software section of this workbook.

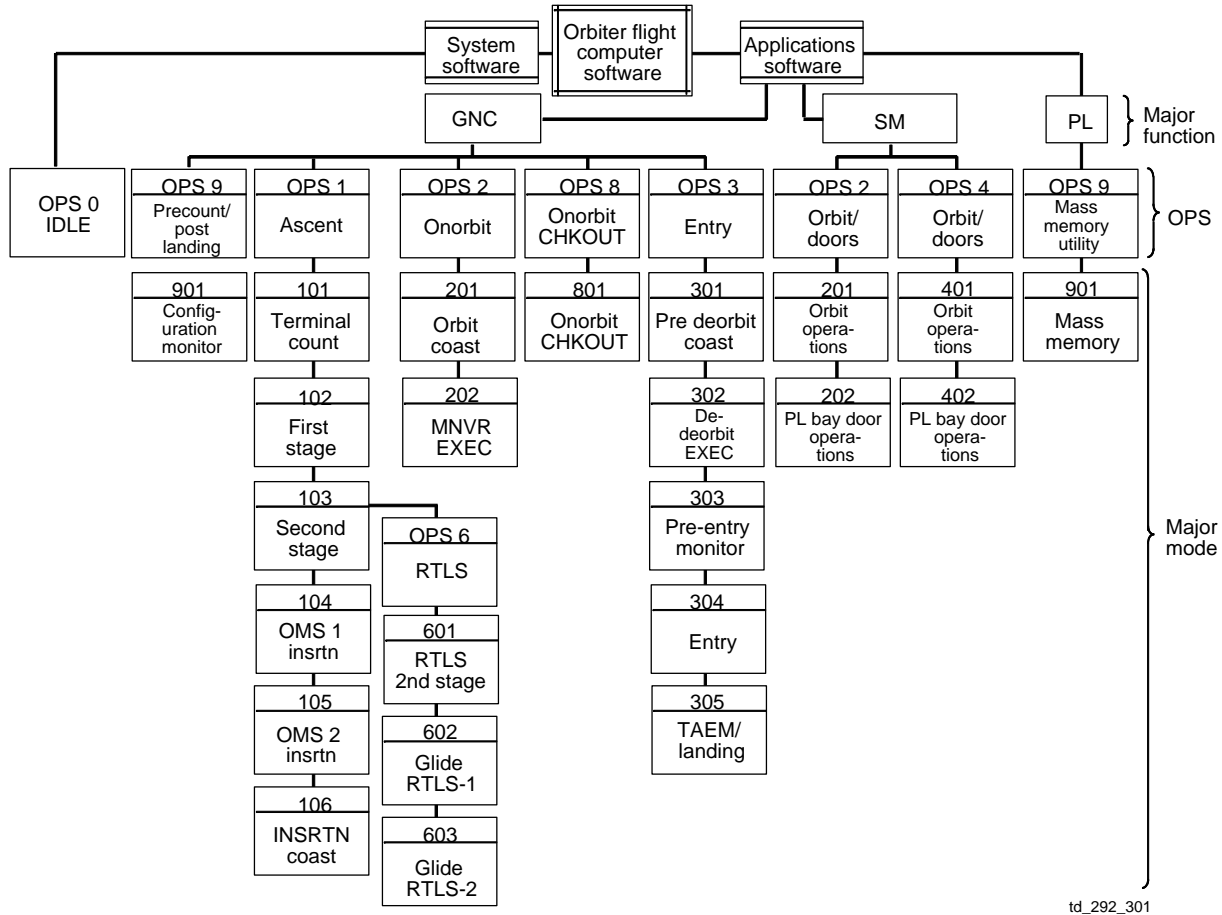

Figure 3-1. Orbiter flight computer software

The third level of displays is that associated with blocks of software called display functions. These are the “disp” displays and are also invoked by a SPEC XYZ PRO keyboard entry. These displays can only be used to view systems parameters. They do not allow manipulation of the system via item entries. The disps will overlay the current OPS display and the current spec display if a spec has been invoked. Use of the RESUME key terminates the disp and recalls the previous OPS or spec. Detailed information on the displays and their hierarchy is presented in the Crew Software Interface CBT (CSI 21057). There are two systems-level disps. The first is the FAULT SUMMARY display, which is invoked by using the FAULT SUMM key on the Keyboard Unit (KBU) and is available in all memory configurations. Another systems-level disp, called GPC/BUS STATUS, is invoked by a regular keyboard entry (SPEC 6 PRO) and is available in all memory configurations.

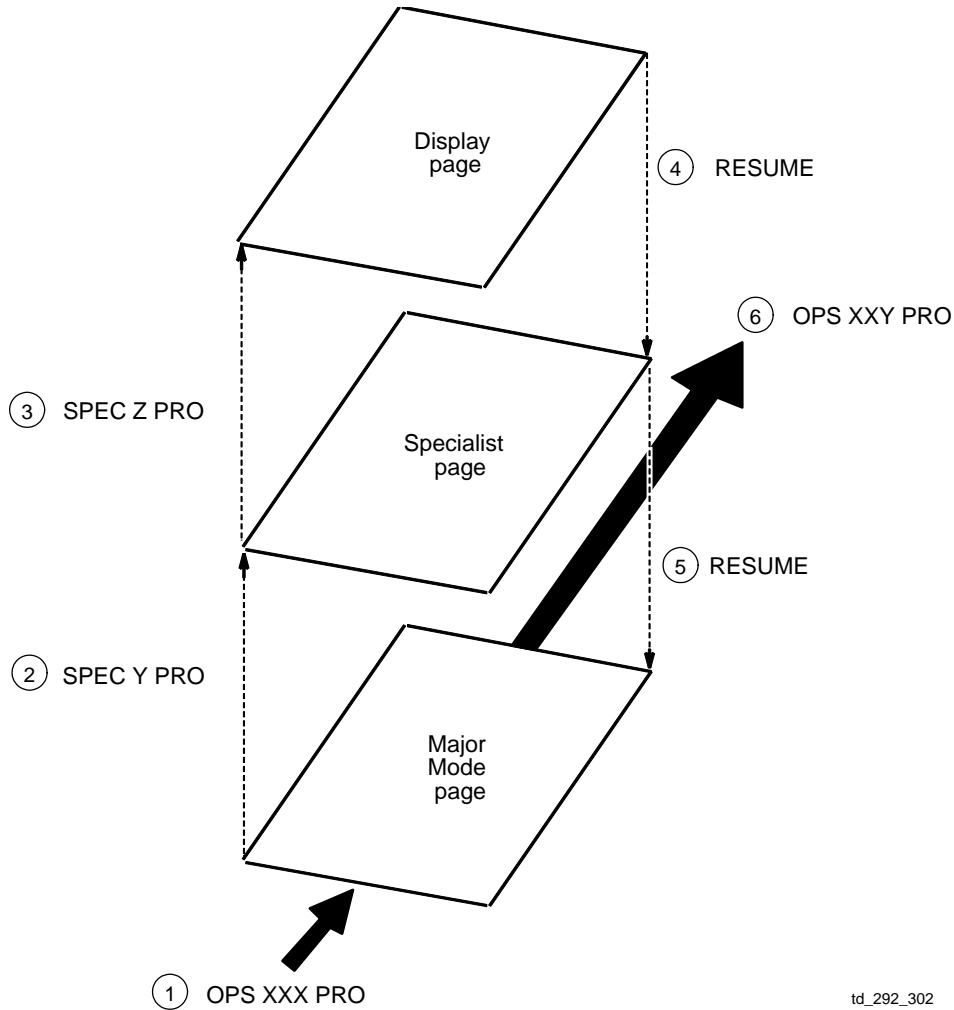

Figure 3-2. Keyboard entries resulting in display changes

3.1.3 GPC Modes

The GPC mode switches control the processing of software in the GPC and have three positions: HALT, STANDBY (STBY) and RUN. They are located on Panel O6 (Figure 3-3).

In the HALT mode, the GPC is in a hardware-controlled state in which GPC firmware is executed. The GPC MODE switch, the IPL SOURCE switch, the MMU ready discretes, and the GPC IPL pushbutton discretes are all monitored in this state. (The GPC needs to know if an IPL is to be performed while the switch is in HALT or if it is to be moded up to STBY or RUN.) Since it is a hardware-controlled state, GPCs that fail-to-sync with the other GPCs are moded to HALT as soon as possible to put them in a safe, known state and to prevent the failed GPCs from outputting erroneous commands, possibly due to bad software. The MODE tb is always barberpole when a GPC is in HALT and an IPL is not being performed.

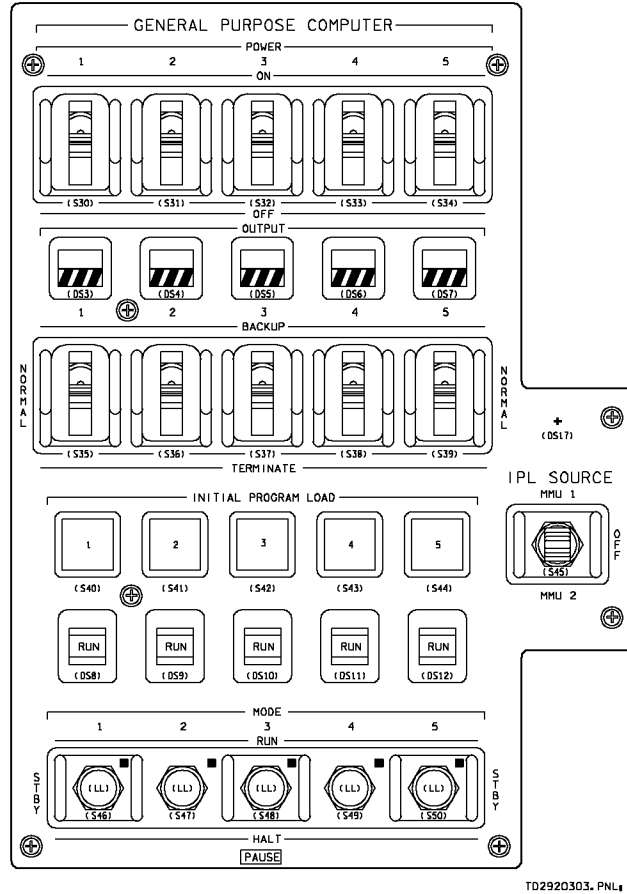

Figure 3-3. Panel O6

In the STBY mode, the GPC is in a state in which the normal PASS software cannot be executed, but it is a software-controlled state. In this state, the GPC MODE switch position discrettes are monitored. It is necessary, as a matter of procedure, that a GPC being moded from RUN to HALT be temporarily moded to STBY before going to HALT. The reason for this procedure is that moding to STBY allows for an orderly software cleanup that then allows a GPC to be correctly reinitialized, without the necessity of performing another IPL. If a GPC is moded directly from RUN to HALT (without pausing in STBY), there is no guarantee that it can correctly perform its functions upon being moded to RUN once again. In STBY, the GPC also resets its diagonal CAM light if less than two fail votes remain.

There is no STBY indication on the talkback. However, the talkback changes when a GPC is moded to STBY. It becomes bp when going from RUN to STBY to indicate that PASS has shut down in this GPC and goes to RUN when moding to STBY from HALT to indicate successful handover from hardware to software control.

In the RUN mode, the GPC supports its normal OPS-assigned vehicle operations. Whenever a GPC is moded from STBY to RUN, it initializes itself to a state where only the systems software is being processed. This is called OPS 0. If a GPC was in another OPS before being moded out of RUN (and has not been IPL'd since), that

software is still resident in main memory but it does not begin processing until that OPS is recalled via keyboard entry. The MODE talkback always reads RUN when the switch is in RUN and the GPC is not failed.

Figure 3-4 illustrates the location on the GPC/BUS STATUS display that indicates the current mode of each PASS GPC in the Common Set (CS). Note that the display does not differentiate between STBY and HALT; i.e., only RUN or HALT is displayed. Since the BFS GPC does not communicate with the PASS GPCs over the ICC data buses, data pertaining to this GPC (in this case, GPC 5) is absent from this display.

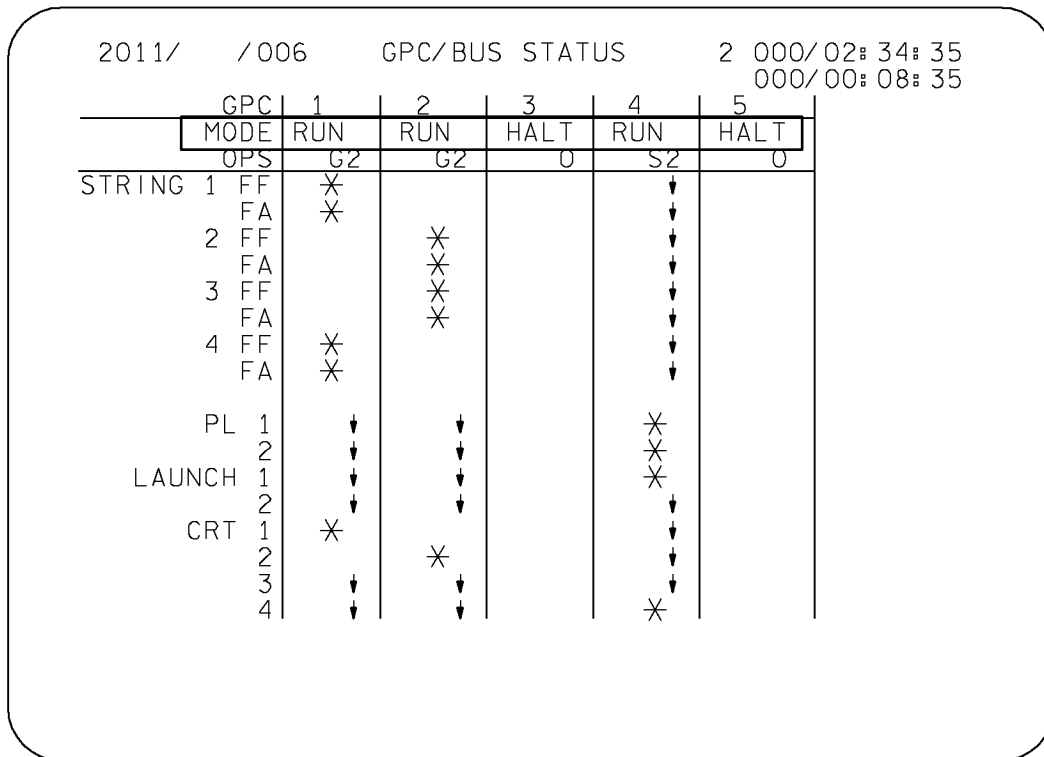

5217. CRT: 2

Figure 3-4. SPEC 6 - GPC/BUS STATUS display

3.1.4 Synchronization

Synchronization (sync) refers to the software scheme that is used to ensure simultaneous intercomputer communication of necessary GPC status information among the PASS GPCs. It is also utilized to ensure that all the appropriate GPCs have received certain data and error information.

3.1.4.1 Common Set

A CS is a set of PASS GPCs that cyclically exchanges certain status information over the ICC data buses at specified CS sync points. (Certain discrete lines, collectively called the sync discrettes, are also used in this process.) This exchanged status

information includes fault messages, OPS overlay requests, input/output errors, GPC status matrix data, IDP major function switch settings, GPC/CRT keyboard entries, uplink information, and MTU time. The GPCs in the CS can be executing different software. For example, on orbit, the CS may include a GPC executing GNC software and a GPC executing SM software. Except for GPC failure situations, all PASS GPCs are in the CS whenever they are in the RUN mode.

3.1.4.2 Redundant Set

A Redundant Set (RS) is a set of PASS GPCs simultaneously executing identical software with the use of identical inputs and producing identical outputs. The GNC major function is the only kind of software that allows RS processing, which is due to the criticality of vehicle control. If one or more GPCs in a RS fail, the others will have the exact information the failed GPCs had and will be able to carry on the GNC functions. The RS GPCs exchange information at a very fast rate. RS GPCs are always members of the CS. An RS is automatically formed whenever a new GNC OPS transition is performed (depending on which GPCs have been assigned to that OPS). All RS GPCs are in the CS, but the reverse is not always the case.

3.1.4.3 Simplex GPC

A simplex GPC is a GPC that is in RUN and is not a member of the RS. It may be a member of the CS, but it does not have to be. For example, the BFS GPC would be a simplex GPC that is not a member of the CS. However, any active PASS GPC that is not failed will be in the CS. SM and PL major functions are always in a simplex GPC.

3.1.5 Data Bus Assignment

All of the GPCs' data and commands (except discretetes) travel over the data buses. Each data bus (with the exception of the intercomputer data buses) is a bidirectional data bus. That is to say, the traffic on that data bus can flow in either direction. Of course, problems would develop if more than one GPC attempted to issue commands over the same data bus at the same time; therefore, a scheme had to be developed to ensure, as well as could be done, that this situation does not develop. Also, more than one GPC may be required to receive information transmitted over a data bus. These requirements led to the command and listen modes of GPC communication over a data bus. Figure 3-5 illustrates five GPCs that are communicating over FC data bus 1 with FC forward MDM 1. Let us assume that this figure illustrates the arrangement during the launch phase of a flight. In this mission phase, GPCs 1-4 are operating in an RS, and GPC 5 contains BFS software. In addition, GPC 1 has been assigned as the commander of string 1 and, therefore, the FC1 data bus. Thus, the GPC 1 transmitter is enabled on FC1. As you have learned previously, the four GPCs operating in the RS all need to receive the same information at the same time. All four of these GPCs, therefore, must listen on the data bus; i.e., their receivers must be enabled on FC1. In addition, GPC 5 requires certain information in order to perform its functions as the BFS GPC and, therefore, must listen to the transactions on this data bus also.

In this case, when all the GPCs expect a time update from MTU accumulator 1, GPC 1 is the only GPC that actually issues a command to accumulator 1 because GPC 1 is in command of the bus connected to the MDM that interfaces with accumulator 1 of the MTU. All of the GNC GPCs receive the answer because they are listening to the response data transmitted over this data bus. (The synchronization processes ensure that they are all listening at the right time).

During ascent and entry, when there are four PASS GNC GPCs, each string is assigned to a different GPC to maximize redundancy. That way, loss of data or erroneous commands from a “failed” GPC is minimized. However, no matter how many GPCs are available, all strings should be assigned and distributed as evenly as possible.

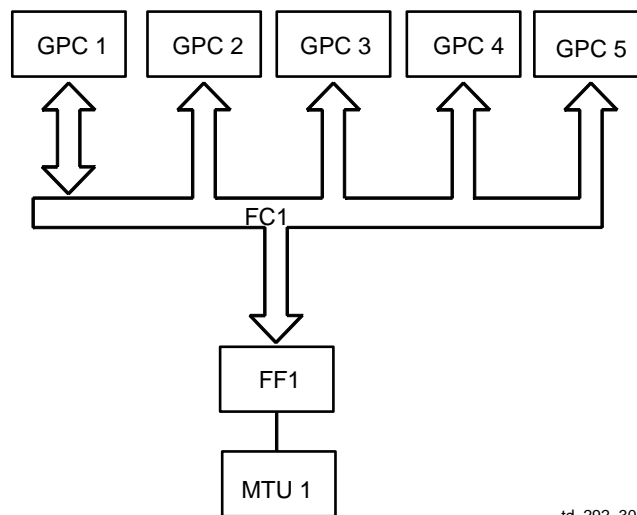

td_292_305

Figure 3-5. GPCs communicating with Flight Forward MDM 1

3.1.6 Memory Configurations

After a GPC has been IPL'd, the only software resident is the system software and the GPC is in OPS 0 when moded to RUN. Any applications software is loaded in from the MMU during an OPS transition. There are two levels of applications software: the Major Function Overlay (MFO) or Major Function Base (MFB) and the OPS overlay. The MFB is that software common to all OPS in a particular major function. For GNC, the MFB contains FC software and data that is retained from one mission phase to another, such as the current state vector and Inertial Measurement Unit (IMU) calibrations. When a GPC is transitioned from one OPS to another in the same major function (e.g., from GNC OPS 1 [ascent] to OPS 2 [orbit]), the MFB remains in main memory, and only the OPS overlay is loaded in from the MMU and written over the old OPS. Of course, when the major function changes (e.g., when GPC 4 is transitioned from GNC OPS 1 to SM OPS 2), a new MFB for the new major function is loaded in from the MMU along with the OPS overlay.

The controls for performing an OPS transition (i.e., loading a new memory configuration into the GPC from the MMU) are on SPEC 0 - GPC MEMORY display, which is also the OPS 0 OPS display. Item 1 determines the memory Configuration (CONFIG) to be loaded. Currently there are eight different memory CONFIGs, besides memory CONFIG 0, which is the post-IPL OPS 0 (no applications software loaded). The different memory configurations are listed in Figure 3-6 along with the OPS contained in each. For example, SM OPS 2 is MC4 so "S2" will be displayed in parentheses after an ITEM 1 + 4 EXEC (Figure 3-7).

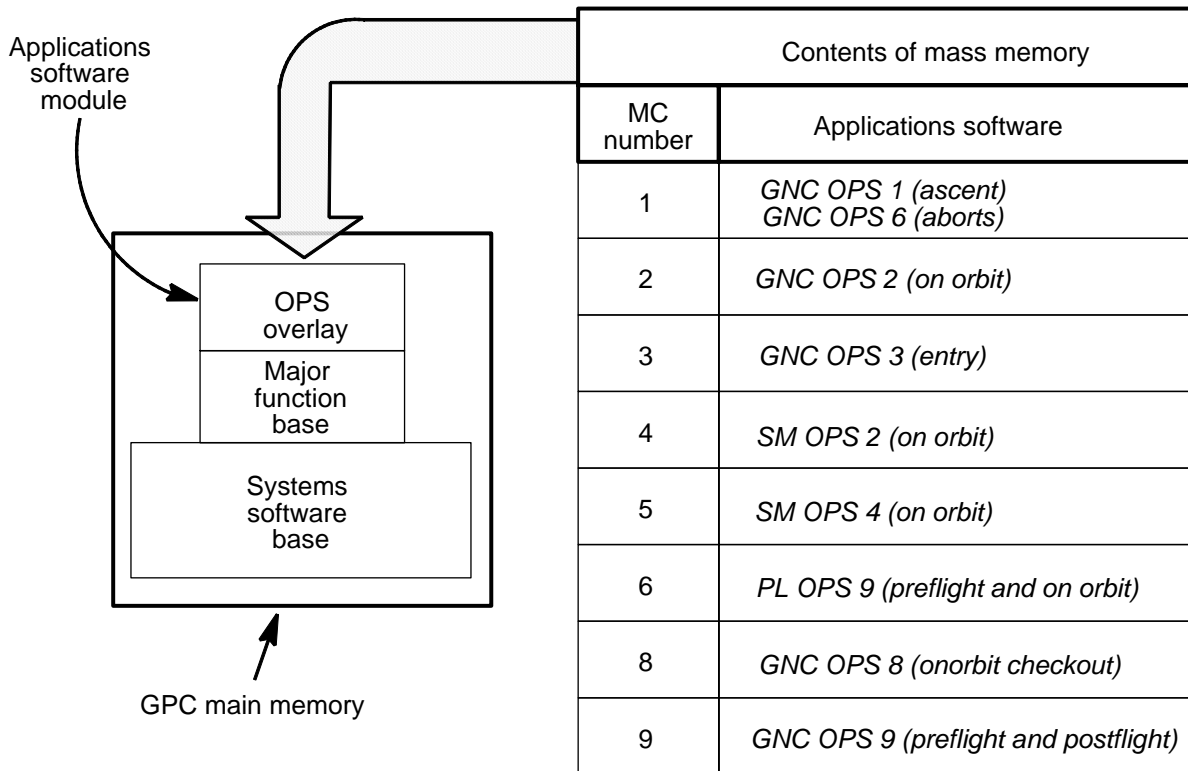

td_292_305

Figure 3-6. Applications software memory configurations

Note: That for all GNC OPS, the memory configuration has the same number as the OPS. The memory configuration numbers for the PL and two SM OPS just have to be memorized. (MC 7 has been deleted). When the memory configuration number is entered via item 1, the associated OPS number and the first letter of its major function are displayed next to it.

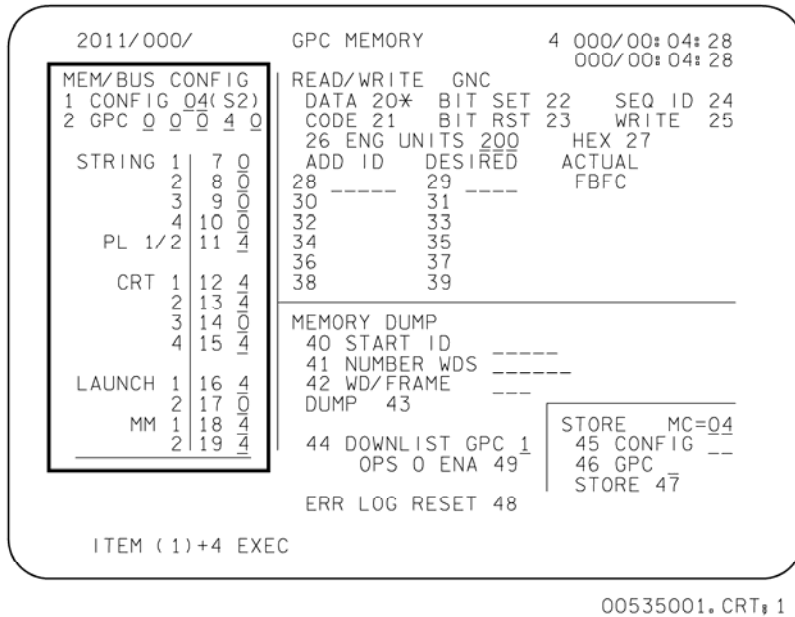

Figure 3-7. SPEC 0 - GPC MEMORY display

3.1.7 Nominal Bus Assignment Table

Associated with each memory configuration is a Nominal Bus Assignment Table (NBAT). It is displayed via items 2 to 19 on SPEC 0 whenever a memory configuration is entered via item 1 and tells which GPC is to be in command of each data bus. The nominal assignments are already loaded in the GPC software preflight. However, these bus assignments may be changed any time an OPS transition is performed. Whether referring to the preloaded or to off-nominal assignments, the table is still referred to as the NBAT for a particular OPS.

A typical NBAT is shown in Figure 3-8 on SPEC 0 - GPC MEMORY for GNC OPS 3.

- Items 2 - 6 determine which GPCs will be in the OPS. They are referred to as the “target” GPCs. In this case, GPCs 1 to 4 are in an RS. If a GPC is not to be in that OPS, a 0 is entered in that GPC item number, which is one more than the GPC number. (Item 2 is for GPC 1, etc.)
- The commanders of the FC data buses or strings are entered in items 7 to 10. (String 1 is FF1 and FA1, etc.) In this example, each GPC is set to command its same-numbered string.
- The two PL buses are assigned together. For OPS 3 they are assigned to GPC 1 via item 11 in case the BFS fails. Normally, when the BFS is in RUN (as for entry), it commands the PL data buses.
- CRTs 1, 2, 3 are assigned to GPCs 1, 2, 3, respectively, via items 12 to 14. Since the PASS can only control three CRTs at a time, no GPC is assigned to CRT 4 during entry. Note that CRT assignments are for that particular major function only.

- e. The launch data buses are assigned via items 16 and 17. Since they have no function during entry, they are deassigned.
- f. Items 18 and 19 show that, if needed, GPC 1 will command MM1 for the OPS 3 transition, and GPC 2 will command MM2 if the transaction fails on MM1 or MMU2 is prime selected on SPEC 1. (More on this later.)

```

3041/000/          GPC MEMORY          1 012/18: 27: 49
                                     000/00: 03: 40
MEM/BUS CONFIG  READ/WRITE  GNC
1 CONFIG _3(G3)  DATA 20*  BIT SET 22  SEQ ID 24
2 GPC 1 2 3 4 0  CODE 21  BIT RST 23  WRITE 25
                                     26 ENG UNITS  HEX 27*
STRING 1 | 7 1
          2 | 8 2
          3 | 9 3
          4 |10 4
          PL 1/2 |11 1
          CRT 1 |12 1
              2 |13 2
              3 |14 3
              4 |15 0
LAUNCH 1 |16 0
        2 |17 0
        MM 1 |18 1
           2 |19 2
OPS 3 UPLK 50
OPS 3 INIT 51
READ/WRITE  GNC
DATA 20*  BIT SET 22  SEQ ID 24
CODE 21  BIT RST 23  WRITE 25
26 ENG UNITS  HEX 27*
ADD ID  DESIRED  ACTUAL
28 ----- 29 -----
30 ----- 31 -----
32 ----- 33 -----
34 ----- 35 -----
36 ----- 37 -----
38 ----- 39 -----
MEMORY DUMP
40 START ID  -----
41 NO WORDS  -----
42 WDS/FRAME ---
DUMP 43
STORE MC=03
45 CONFIG --
46 GPC
STORE 47
44 DOWNLIST GPC 1
OPS 0 ENA 49
MM AREA
PL 52 1
GNC 53 1
SM 54 1
ERR LOG RESET 48

```

5219. CRT# 1

Figure 3-8. GPC MEMORY display

The NBATs are listed in the Post-Insertion and Deorbit Prep Checklists at the appropriate OPS transition times. They are also listed in the malfunction procedures and pocket checklists for off-nominal cases. Sometimes the ground may call up an NBAT to optimize redundancy after failures in the DPS or in other systems. Note that the FDF NBATs (shown in Figure 3-9) are constructed to be easily entered into the GPC MEMORY display.

It is important to remember that the assignments on SPEC 0 are not necessarily those in effect. The OPS must be called (or recalled) before any of items 2 to 19 take effect.

NOMINAL DEORBIT PREP OVERVIEW OF CONFIGURATION MANAGEMENT

	OPS 1 ASC C/L					OPS 2 ON ORBIT					OPS 2 DEORBIT PREP TIG -03:28					OPS 3 DEORBIT PREP TIG -02:20					SEAT INGRESS TIG -01:00					EI-5	V= 15K										
DPS																																					
GPC OPS	1 G1	2 G1	3 G1	4 G1	5 BFS	1 G2	2 G2	3 G2F	4 SM	5 BFS	1 G2	2 G2	3 G2F	4 SM	5 BFS	1 G3	2 G3	3 G3	4 G3	5 BFS	1 G3	2 G3	3 G3	4 G3	5 BFS												
POWER OUTPUT MODE	ON N R	ON N R	ON N R	ON N R	ON B R	ON N R	ON N R	ON N H	ON T R	ON N H		ON N R	ON N R	ON N H	ON T R	ON N S	ON N R	ON N R	ON N R	ON N R	ON B R	ON N R	ON N R	ON N R	ON N R	ON B R	ON N R										
CONFIG GPC	1 1 2 3 4 0					2 1 2 0 0 0					4(5) 0 0 0 4 0					2 1 2 0 0 0					4(5) 0 0 0 4 0					3 1 2 3 4 0					3 1 2 3 4 0						
STR 1 2 3 4 PL 1/2	1 2 3 4 1					1 2 1 2 0					0 0 0 0 4					1 2 1 2 0					0 0 0 0 4					1 2 3 4 1					1 2 3 4 1						
CRT 1 2 3 4	1 2 3 0					1 2 0 2					4 4 0 4					1 2 0 2					4 4 0 4					1 2 3 0					1 2 3 0						
L 1 2	1 2					0 0					4 0					0 0					4 0					0 0					0 0						
MM 1 2	1 2					1 2					4 4					1 2					4 4					1 2					1 2						
MDM	ALL ON					ALL ON					ALL ON					ALL ON					ALL ON																
D & C	ADI/DDU CRT/DEU INSTR	L, R 1, 2, 3 L, R				L, A 1, 2, 4-ON NONE					L, R L, R					1, 2, 3-ON																					
E C L S	AV BAY FAN CABIN FAN IMU FAN WATER LP FREON LP RADIATOR	1-B, 2-A, 3-B A B				1-OFF, 2-ON 1-B, 2-B Stow					1-GPC, 2-ON					1-OFF, 2-ON																					

td292_012

Figure 3-9. NBAT configuration

To see what bus assignments are actually in effect for each memory configuration, the GPC/BUS STATUS display (SPEC 6 in Figure 3-10) should be viewed.

The OPS line tells which memory configuration is loaded in each PASS GPC and asterisks display which GPC is commanding each of the data buses.

Down arrows are displayed for the data buses not assigned to that GPC's memory configuration and by CRTs currently assigned to another major function via the switches. For these instances, a down arrow does not indicate a failure condition.

		GPC/BUS STATUS					2 000/02: 34: 35 000/00: 08: 35	
2011/ /006		1	2	3	4	5		
GPC		RUN	RUN	HALT	RUN	HALT		
MODE		G2	G2	0	S2	0		
OPS								
STRING	1	FF	*				↓	
		FA	*				↓	
	2	FF		*			↓	
		FA		*			↓	
	3	FF	*				↓	
		FA	*				↓	
	4	FF		*			↓	
		FA		*			↓	
							↓	
	PL	1	↓	↓		*		
		2	↓	↓		*		
	LAUNCH	1	↓	↓		*		
	2	↓	↓		↓			
CRT	1	*					↓	
	2		*				↓	
	3	↓	↓				↓	
	4	↓	↓		*		↓	

5220. CRT: 2

Figure 3-10. GPC/BUS STATUS display

3.1.8 Memory Reconfiguration

Once the NBAT for a particular memory configuration is set up, the OPS transition or memory reconfiguration is requested via an OPS XXX PRO (must always be three digits). The system software then directs that any new software required be loaded in from mass memory, upper memory, or another GPC. If there is no change in major function, then only the OPS overlay is loaded in, otherwise the major function overlay is also loaded into the GPC(s). An OPS transition may take as long as 70 seconds (if tape-type MMUs). During the overlay process, GPC MEMORY will be displayed on any CRT commanded by a GPC involved in the OPS transition. A big X will be displayed on the CRT just before the transition is complete for SM OPS transitions.

If a legal OPS transition is requested, the necessary OPS overlay (and the necessary major function overlay, if required) will be loaded into all target GPCs, as specified in the memory configuration table. It should be noted, however, that a user input requesting that a simplex memory configuration (SM OPS 2, PL OPS 9, and SM OPS 4) be loaded into multiple GPCs (via modification of the memory configuration table) will be rejected. (Also, note that SM OPS 4 itself is not available on most flights.) In other words, neither PL nor SM software can be run redundantly. Also, if a target GPC is new to the major function configuration and is not in OPS 0 when the reconfiguration is requested, the request will be rejected, and a class 3 alarm tone and the GPC CONF fault message will be generated. An attempt to reconfigure a GPC that is not a member of the CS (the BFS GPC, for example) also results in a class 3 alarm and a GPC CONF fault message.

If an illegal OPS transition is requested, the fault message ILLEGAL ENTRY appears. Also, it should be pointed out that if a GPC is running in a certain major function but is not a target GPC for another OPS (memory configuration in that major function), then that GPC will be forced to OPS 0 (i.e., stop application software processing) when that OPS is requested. Thus, within a major function, only one OPS may be active. For example, when transitioning to the on-orbit configuration, GPCs 1, 2, and 4 are all still in GNC OPS 1 at that time, but only GPCs 1 and 2 are targeted for GNC OPS 2 (GPC 4 is to be the SM GPC). Therefore, when OPS 201 PRO is entered to GNC, GPC 4 goes to OPS 0. It can then be transitioned to SM OPS 2 separately.

Transition to GNC OPS 3 represents a special case for OPS transitions. During the transition from GNC OPS 9 (ground OPS-prelaunch) to GNC OPS 1 (countdown to liftoff), a copy of the GNC OPS 3 (entry) software is loaded into the upper memory of each PASS GPC. This is the only time that this can happen. (The BFS is not involved in this process. It has its own GNC OPS 3 as part of its regular programming.) This upper memory copy of OPS 3 is called the “G3 archive.” On any subsequent transition to GNC OPS 3 by any GPC that has a G3 archive, the GPC can obtain the GNC OPS 3 overlay from its own upper memory vs. the MMUs. This procedure makes transitions to GNC OPS 3 much faster and was implemented as a safety factor for the potential transition from GNC OPS 1 to GNC OPS 3 that would be performed in the event of a Transoceanic Abort Landing (TAL) ascent abort. If a PASS GPC had been IPL'D on orbit (i.e., had lost its G3 archive) and was involved in the GNC OPS 2 to GNC OPS 3 transition, then it would obtain its GNC OPS 3 overlay from one of the other GPCs involved in the transition or from the MMUs. Items on SPEC 1 (DPS UTILITY) allow the crew control over whether the G3 archive will get loaded in the first place and whether it is allowed to be used for a transition to OPS 3.

3.1.8.1 OPS/Mode Recall - Restringing

When it is desired to change the GPCs or bus assignments for a particular OPS that is currently running, an OPS/mode recall is performed. That is, the NBAT is changed as desired on SPEC 0, then the current major mode is requested via an OPS XXX PRO.

Technically, data buses may be reassigned in any major mode by recalling that mode. However, current flight rules prohibit restringing when not in a safe orbit (i.e., in GNC OPS 102, 103, 104, 105, 601, 602, 603, 303, 304, and 305) except for certain serious failure scenarios.

It is important to note that restringing cannot be accomplished by going from one major mode within an OPS to another. For a change in the NBAT to take effect, the new major mode must be called again after the major mode transition takes place. (This is to prevent inadvertent changes to the bus assignments.)

The software limits when the target set (those GPCs assigned to an OPS) may be changed. Requests to add or delete GPCs from the current memory configuration are accepted only in the following major modes: GNC 201, 301, 801, 901; that is, in the first major mode of any GNC OPS except OPS 1 and 6. In any other major mode, a request

to perform an OPS/mode recall with a change in the target set is denied with a class 5 fault message: ILLEGAL ENTRY.

3.1.9 OPS 0

Any GPC in RUN that is not processing any applications software is said to be in OPS 0. For example, after a GPC is IPL'd, it is in OPS 0 until an OPS transition is performed. Whenever a GPC is IPL'd, it is loaded with all the usual system software common to every memory configuration (which includes the GPC MEMORY, FAULT, DPS UTILITY, TIME, and GPC/BUS STATUS displays) and the software to load the IDPs. This is the only time a GPC in OPS 0 can IPL the IDPs.

A GPC can also be in OPS 0 with a memory configuration loaded into it if that software is not being processed. In this case, the IDP load software has been overwritten.

There are three ways a GPC can be put in OPS 0 after another memory configuration has been loaded:

- a. A crew entry of OPS 000 PRO will mode a GPC to OPS 0 if it is in GNC OPS 201 or 901 or any SM or PL major mode. Attempting to PRO to OPS 0 in any other MM results in an ILLEGAL ENTRY fault message. Note that if a GNC RS exists, a successful OPS 000 PRO to a GNC CRT results in all members of the RS going to OPS 0 since any keyboard entry to any RS GPC goes to all the RS GPCs.
- b. Any time a PASS GPC is moded from RUN to STBY or HALT and then back to RUN, it will be forced into OPS 0. This is the way to take one GPC in a RS to OPS 0.
- c. If a GPC is running in the GNC major function but is not selected as a target GPC for the next GNC OPS transition, it will be forced to OPS 0 at the transition.

An important point to remember here is that the memory configuration of a GPC (forced to OPS 0) is not changed. This is especially evident in the case when a GPC is forced to OPS 0 by a transition of its MODE switch. No new software is loaded, and none is erased. Only the GPCs level of processing is altered. Therefore, a GPC can be running in OPS 0, for example, and at the same time contain OPS 2 software (as illustrated in the freeze-dry concept, to be presented next).

To leave OPS 0, a PASS GPC must be moded to GNC OPS 201, 301, or 901 or any SM or PL major mode.

3.1.10 Freeze-Dried GPC

A freeze-dried GPC is a GPC that has been loaded with the software for a particular memory configuration and then moded to STBY. It may then be moded to HALT and allowed to enter sleep mode. Prior to an OPS transition to that memory configuration, the freeze-dried GPC can be moded back to RUN and the appropriate OPS requested. Then, the freeze-dried GPC would serve as an additional memory source for the

requested OPS overlay in case the mass memories failed. This is done in the post-insertion timeframe to test out the MMUs and to store a copy of GNC OPS 2, in case of on-orbit failures.

A GPC may be freeze-dried in two ways:

- a. One way entails calling the desired OPS through a keyboard (after ensuring that the desired GPC is a target for the new memory configuration). Then, the desired GPC is moded to STBY, then HALT. It is then called a backout freeze-dried GPC. This is not a flight-certified mode of operation and is procedurally avoided (whenever possible) by immediately using the items on GPC MEMORY to freeze-dry the GPC in the usual way.
- b. Call up GPC MEMORY, SPEC 0 (Figure 3-11) and use the controls in the right center of the spec. Item 45 specifies the memory configuration to be freeze-dried. Item 46 allows input of the GPC to receive the freeze-dried load. Enter the appropriate values in items 45 and 46, and then do an ITEM 47 EXEC. This freeze-dry loads the desired memory configuration into the desired GPC. When the load is complete, the currently loaded memory configuration is shown in the line above item 45. Then the GPC can be moded to STBY and HALT. With this method, no processing is actually begun, but the software is there and reliable for future use. This is the procedure used in the Post-Insertion Checklist to freeze-dry GPC 3 as a G2 GPC in order to check the MMUs before committing to OPS 2.

Note: The BFS GPC is sometimes referred to as being freeze-dried on orbit when it is placed in HALT. This is because the BFS GPC can then be moded to RUN prior to entry and will begin processing entry software following the OPS 3 request without having to access a mass memory. (All BFS software is loaded into the BFS GPC at IPL.)

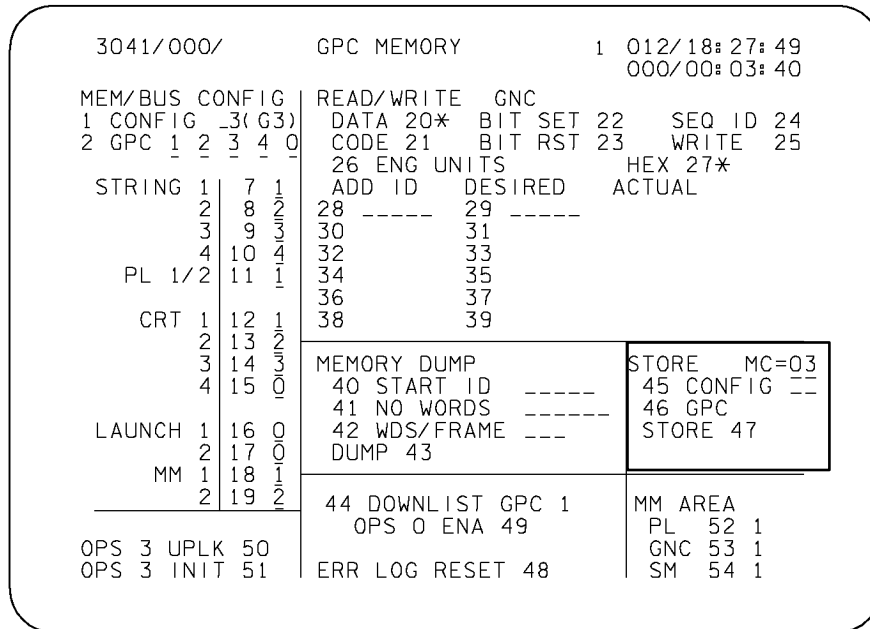

5221. CRT# 3

Figure 3-11. GPC MEMORY display

In the unlikely event that all currently processing G2 GPCs fail (most probably due to a programming error in their software), the freeze-dried GPC can be used to quickly regain GNC functions. (Mission Control Center (MCC) will need to do a couple of uplinks.) Since the freeze-dried GPC is loaded with G2 also, care would be taken to avoid repeating the sequence of steps that lead to the failure in the first place. Also, if the G2 software is deemed to be so unreliable that G3 is needed, it is contained in the G3 archive in the upper memory of each PASS GPC (unless re-IPL'd) and is immediately available for a transition to GNC OPS 301.

3.1.11 Sample Procedure: Config GPCs for OPS 2

A major DPS transition is involved when going from the ascent to orbit configuration. It involves two different memory configurations running simultaneously in different GPCs and freeze-drying another. This procedure is one of the first things done in the Post-Insertion Checklist and is shown in Figure 3-12. The various steps of this procedure are explained as an example of a nominal memory reconfiguration. (Steps inside asterisks involve off-nominal conditions and are not discussed.)

In overview, the GPCs will be configured for on orbit by freeze-drying GPC 3 with GNC OPS 2, putting GNC OPS 2 in GPCs 1 and 2, SM OPS 2 in GPC 4, and putting the BFS GPC to "sleep." Also, any procedures bordered by asterisks are contingency procedures that are used only if a failure has occurred.

Step 1 - Before GPC 3 is taken out of the GNC RS, its string is assigned to another GPC. This is done by calling up MC1 on SPEC 0 and doing an ITEM 9 + 2 EXEC, which gives string 3 to GPC 2 (per the NBAT shown). Then an OPS/mode recall is

performed to make the restringing take effect. (Remember that changing the NBAT alone is not enough; you must invoke it via the OPS/mode recall.)

Step 2 - The only way to take the GPC to be freeze-dried (nominally GPC 3) out of the RS is to take it to STBY. This causes the other PASS GPCs to vote against it (CAM lights, F7 "GPC" light, master alarm, and fault message) just as if it had failed. When it is taken back to run, it joins the CS (but not the RS) in OPS 0.

Step 3 - Once in OPS 0, GPC 3 can be loaded with G2 via the STORE controls (ITEMs 45 to 47) on SPEC 0. The G2 software will come from the MMU. Note that no execution of OPS 2 software takes place at this point; it is only loaded into GPC 3.

Step 4 - G2 is then loaded into GPCs 1 and 2. If GPC 2 is to be HALT'd and allowed to "sleep" to save power (single G2 configuration), GPC 1 is assigned all the data buses for G2. (GPC 2 would be freeze dried before finishing block 1 and could later be activated and used as a source of G2 if necessary.) Otherwise, the buses are divided between GPCs 1 and 2 as indicated. During the OPS transition, only the OPS overlay is loaded from mass memory into GPCs 1 and 2, since they already have the GNC MFB. Since GPC 4 is not targeted for G2, it ends up in OPS 0 after the transition. It is still in the CS, but it is no longer in the RS.

Step 5 - Since the BFS cannot listen to the PASS in OPS 2, it annunciates its loss of track by blinking the BFC light on Panels F2 and F4. (The BFS only has ascent and entry phase functions. Thus, there was no need to program it to be able to listen to PASS on-orbit operations; the only reason to listen to PASS is to be able to take over from PASS on engage.)

CONFIG GPCS FOR OPS 2 1

- For single PASS GPC failure, build PASS set as follows:
 - FAILED GPC
 - GPC

		1	2	3	4
1	X	G2	FD	SM	
2	G2	X	FD	SM	
3	G2	FD	X	SM	
4	G2	SM	FD	X	

- In step 1:
 - Assign strings 1 & 3 to one GPC and strings 2 & 4 to other GPC

NOTE

Do not perform any keyboard entries or switch throws 10 sec before and after moding PASS GPCs to RUN or making OPS transition requests

C.P 1. **REASSIGN G2FD STRING TO ANOTHER GPC IN MC1**

SNC 0 GPC MEMORY
CONFIG - ITEM 1 +1 EXEC
Modify MC1 per table
BFC CRT DISP - OFF
GNC, OPS 106 PRO
SNC 0 GPC MEMORY

CONFIG GPC	1
STR	12340
	1
	2
	3
	2
	4
	4
PL 1/2	1
CRT	1
	1
	2
	2
	3
	2
	4
	0
L	1
	1
	2
	2
MM	1
	1
	2
	2

CAUTION

If BFS is standalone (BFC It flash):
BFC CRT DISP - ON
BFS, GNC I/O RESET
BFC CRT DISP - OFF

O6 2. **MODE G2FD GPC TO OPS 0**
GPC MODE G2FD - STBY (tb-bp)
- RUN (tb-RUN)

CRTX 3. **LOAD MC2 INTO G2FD GPC**
PL, GPC/CRT G2FD GPC/X EXEC
X: PL GPC MEMORY
CONFIG - ITEM 45 +2 EXEC
GPC - ITEM 46 +(G2FD) EXEC
STORE - ITEM 47 EXEC
Store complete when MC = 02

- If no MC = 02 after 30 sec:
 - a. On MCC GO, cycle pwr on MMU 1,2; wait 34 sec
 - b. Retry GPC FREEZE DRY(step 3)
 - c. If FD successful, continue with step 4
If not successful and:
NO GPCs FAILED: go to step 1, delete GPC3 from TGT SET, restrng 1,3 to GPC 1, and restrng 2,4 to GPC 4, try to FD GPC 2 with steps 2,3; then go to step d
ONE GPC FAILED: go to step 1, delete attempted FD GPC from TGT SET, restrng all strings to lowest ID GPC, try to FD other GPC with steps 2,3; then go to step d
 - d. If FD successful, continue with step 4
If not successful: consider both MMUs failed; on MCC GO, perform transition to OPS 3

4. **TRANSITION TO GNC OPS 2**

SNC 0 GPC MEMORY
CONFIG - ITEM 1 +2 EXEC
Modify MC 2 per table
GNC, OPS 201 PRO
SNC UNIV PTG

CONFIG GPC	DUAL G2	SINGLE G2
	2	2
STR	1	1
	2	1
	3	1
	4	1
PL 1/2	0	0
CRT	1	1
	2	1
	3	0
	4	1
L	1	0
	2	0
MM	1	1
	2	1

5. **TURN OFF BFC LT**
BFC CRT DISP - ON
BFS, MSG RESET
BFC It - off
CRT DISP - OFF

1-2

PI/112/FIN

Figure 3-12. Post-Insertion Checklist

MET
DAY 000
00:30
TRANS
DAP
AUTO
RT 0.5
DB 3.5

00:35

00:40

00:45

00:50

00:55

A1 (B1)
AUTO
PRI
RT 0.2
DB 5.0

01:00

Ref ASC for activities from 00:00-00:50 MET

MEMORY CONFIGURATION TABLE				
CONFIG	1	2	3	4 (5)
OPS	G1, G6	G2	G3	SM
GPC SEL	1,2,3,4	1,2	1,2,3,4	4
STR	1 2 3 4	1 2 1 2	1 2 3 4	0 0 0 0
P/L	1/2	1	0	1
CRT	1 2 3 4	1 2 0 2	1 2 3 0	4 4 0 4
L	1 2	1 2	0 0	4 0
MM	1 2	1 2	1 2	4 4

1: GNC OMS 2 MNVR COAST 2: GNC OMS 2 MNVR COAST
3: BFS, SYS SUMM 2

C L4:B,Q,R All cbs closed
:J cb AC3 @A SIG CONDR HUM SEP - cl
@B SIG CONDR IMU FAN - cl

MS,PS **SPECIALIST SEAT EGRESS**

C,P **CONFIG GPCs FOR OPS 2** [1], 1-2
(USE DUAL G2 CONFIG)
If two PASS GPCs FAILED, *MCC
If BFS engaged: Go to MAL, **DPS**, GPC FRP-4

MS **PRELIM MIDDECK CONFIG** (MID Cue Card) [2], 1-15

MS **AFT STATION CONFIG** (AFT Cue Card) [3], 1-13

6. **TRANSITION TO SM OPS 201 (401)**
SM_GPC/CRT SM GPC/X EXEC
X: SM GPC MEMORY
CONFIG - ITEM 1 +4(5) EXEC
Modify MC 4(5) per table

CONFIG	4(5)
GPC	00040
STR	1 0
	2 0
	3 0
	4 0
PL	1/2 4
CRT	1 4
	2 4
	3 0
	4 4
L	1 4
	2 0
MM	1 4
	2 4

SM OPS 201 (401) PRO
SM ANTENNA
*UPLK - ENA
SM 1 DPS UTILITY
UL CNTL AUTO - ITEM 35 EXEC

7. **SECURE BFS**
BFC CRT DISP - ON
BFS_GNC_OPS 000 PRO
3: BFS, BFS MEMORY
BFC CRT DISP - OFF
*All IDPs deassigned from BFS

8. **RECONFIG MEDs**
GPC/CRT 0/3 EXEC
IDP/CRT 3 PWR - OFF
*4 PWR - ON

9. **LOAD ORBIT TFLs**
*OI PCMMU FORMAT - GPC
SM 62 PCMMU/PL COMM
FORMAT:
FXD - ITEM 1 EXEC (*)
SEL ID - ITEM 3 +1 6 1 EXEC
LOAD - ITEM 4 EXEC
- *RUN,CPLT
SEL ID - ITEM 3 +1 0 3 EXEC
LOAD - ITEM 4 EXEC
- *RUN,CPLT
PGM - ITEM 2 EXEC
SM ANTENNA

CRTX
C3
C3
C3
O6
C2
R11L
F6,F7,F8
C3
CRT

Figure 3-12. Post-Insertion Checklist (continued)

10. **RECONF GPCs**

O6 GPC MODE 5 - HALT (tb-bp)
 OUTPUT 5 - NORM (tb-bp)
 OUTPUT (SM GPC) - TERM (tb-bp)

If no failed GPC:
 *All IDPs deassigned from FD GPC
 GPC MODE (FD GPC) - STBY (tb-bp)
 - HALT (tb-bp)
 - STBY (tb-RUN)
 - HALT (tb-bp)

If single G2 reqd:
 IDP/CRTX MAJ FUNC - PL
 GPC/CRT 2/X EXEC

X: PL GPC MEMORY
 CONFIG - ITEM 45 +2 EXEC
 GPC - ITEM 46 +2 EXEC
 STORE - ITEM 47 EXEC
 Store complete when MC = 2 (-30 sec)
 *All IDPs deassigned from FD GPC
 GPC MODE 2 - STBY (tb-bp)
 - HALT (tb-bp)
 - STBY (tb-RUN)
 - HALT (tb-bp)

Perform ERR LOG RESET
GNC 0 GPC MEMORY
 ITEM 48 EXEC
SM 0 GPC MEMORY
 ITEM 48 EXEC

If PASS GPC failed from ASCENT and dual G2 reqd, use G2FD to form G2 RS:
GNC 0 GPC MEMORY
 CONFIG - ITEM 1 +2 EXEC
 Modify MC 2 per table
 GNC, OPS 201 PRO
GNC UNIV PTC

If PASS GPC failed from ASCENT and single G2 reqd:
 *All IDPs deassigned from FD GPC
 GPC MODE (FD GPC) - STBY (tb-bp)
 - HALT (tb-bp)
 - STBY (tb-RUN)
 - HALT (tb-bp)

If GPC failed for ASCENT:
 Go to MAL, DPS, GPC FRP-1 as time permits

PI LOCKER When all GPC switch configuration complete, unstow, install GPC MODE switch guard

RAD ACT 7

NOTE
 Expect 'S88 EVAP OUT T 1(2)' message

L1 FLASH EVAP CNTLR PRI A - OFF
 B - ON

NOTE
 If RAD flow has been initiated manually, delay RAD ACT until MCC call or until RAD OUT T low

RAD BYP VLV MODE (two) - AUTO
 CNTLR LOOP (two) - AUTO A
 Wait 90 sec
 *RAD BYP VLV tb (two) - RAD

- * If RAD BYP VLV 1(2) tb - BYP: *
- * RAD CNTLR LOOP 1(2) - AUTO B *
- * Wait 90 sec *
- * *RAD BYP VLV 1(2) tb - RAD *
- * *
- * If RAD BYP VLV 1(2) tb still BYP or bp: *
- * RAD BYP VLV MODE 1(2) - MAN *
- * MAN SEL 1(2) - RAD FLOW *
- * Hold 3 sec or until tb - RAD *
- * If RAD BYP VLV 1(2) tb - bp: *
- * RAD BYP VLV MODE 1(2) - MAN *
- * MAN SEL 1(2) - RAD FLOW *
- * Hold 3 sec or until tb - RAD *
- * If RAD BYP VLV 1(2) tb still bp: *
- * Do not select alternate RAD CNTLR *

L2 FREON ISOL MODE - AUTO

CONFIG	GPC	2	XY
STR	1	X	
	2	Y	
	3	X	
	4	Y	
PL	1/2	0	
CRT	1	X	
	2	Y	
	3	0	
	4	Y	
L	1	0	
	2	0	
MM	1	X	
	2	Y	

Figure 3-12. Post-Insertion Checklist (concluded)

Step 6 - GPC 4, which is now in OPS 0, is given a CRT in the SM major function and taken to SM OPS 2, after verifying that the appropriate data buses are assigned. Note that the CRTs and MM data buses are assigned to both GNC and SM major functions and commanded by the indicated GPCs on demand. (All systems and payload control by the SM GPC is done over the payload buses, and control of the RMS MCIU is via launch bus 1.) Since the SM can automatically control the uplink block function, the switch is verified to be in Enable (ENA) and the control selected to Automatic (AUTO) on SPEC 1.

Step 7 - Since the BFS is not needed on orbit, it is taken out of OPS 1 and put in OPS 0 to “secure” it. (It is put in HALT in the last step, along with all other GPC moding.)

Step 8 - Since the aft CRT is used on orbit, CRT3 is deassigned and CRT4 assigned to the PASS. Note that CRTs can only be added and deleted in this way. Simply selecting them in an NBAT and doing an OPS transition will not do the trick.

Step 9 - The orbit Telemetry Format Load (TFL) is then loaded. The TFL used for a given flight may well vary, since the data downlist requirements differ from flight to flight.

Step 10 - Finally, all the GPC MODE switches are placed in their “final” orbit config at one time, for efficiency. GPCs 3 and 5 (along with GPC 2, if single G2 OPS is desired) are taken to STBY, then HALT. The MODE switches for the PASS GPCs are then taken back to STBY and then to HALT a second time.

This seemingly peculiar procedure is performed in order to ensure that the GPC had time to perform the proper internal software “putaway” when it was first taken through STBY to HALT. Problems with improper “putaway” and other GPC MODE switch anomalies have happened several times in flight. The GPC MODE switches possess somewhat weak springs and do not snap firmly into their detents at the various switch positions (limited tactile feedback). This can cause the unwary crewperson to move the switch past the intended position (i.e., through STBY, or even all the way to HALT, at least momentarily) and into the region beyond the intended switch detent. This is generally referred to as “switch teasing.” If the specific case is moving through STBY to HALT almost immediately, the PASS GPC software cannot properly terminate all its processes before the firmware that runs in the HALT position takes over. This makes the GPC unable to initialize properly when taken back through STBY to RUN, at a later point in the flight, thereby requiring an IPL to recover the operation of the GPC affected. BFS flight software is not subject to this particular problem and would not be harmed by a switch tease.

The OUTPUT switch of GPC 5 is placed in NORM to prevent an inadvertent BFS engage on orbit, and GPC 4 is taken to TERM as a hardware backup to its software inhibit against commanding the FC data buses. All the GPCs in HALT will enter “sleep” mode in 4.5 minutes. This saves approximately 500 watts of power each.

Special steps exist at the end of step 10 to configure the DPS differently, if a GPC had failed during ascent, etc. A callout to perform a recovery procedure for a failed GPC, as time permits, is also included. This would involve reconfiguring the DPS again and would be coordinated with the MCC. Lastly, a switch guard is installed over the GPC

MODE switches in order to prevent any accidental “bumping” of same by the crew, while moving around in zero-G on orbit.

3.1.12 MMU Assignment

Since there are two identical MMUs, there must be a method to tell the GPCs which one to use for a particular transaction. This is done on DPS UTILITY, SPEC 1 (Figure 3-13) via items 1 through 8. Only one MMU is assigned to each major function. OPS 0 also has an MMU assigned to it for requesting the IDP initialization software for an IDP load (only after GPC IPL). This display is initialized with all major functions assigned to MMU1, and subsequent execution of the item numbers causes the appropriate MMU to be assigned. Note that each of the pairs of item numbers is mutually exclusive.

When a GPC needs to access mass memory, this table tells it which MMU to use. For example, the SM GPC may need to call a roll-in spec or take a checkpoint (discussed later). In the case of OPS transitions, if the MMU selected is busy (BSY) or fails twice, then the other is automatically tried. For a GNC OPS transition where a RS is involved, one GPC is assigned to each MM bus via items 18 and 19 on SPEC 0 (GPC MEMORY, Figure 3-14) for greater redundancy. The indicated GPC commands the MM bus selected by item 1 or 2 on SPEC 1, and the other GPC commands the other MM bus if the first transaction fails. Of course, all GPCs in the RS are listening over both buses and receive the overlay.

3041/001/		DPS UTILITY		1 012/18: 28: 28 000/00: 03: 23	
MMU ASSIGN		PORT ASSIGN		UL CNTL	
1	2				
GNC 1*	2	STRING 1	PRI 15*	16	AUTO 35
SM 3*	4	2	17*	18	ENA 36*
PL 5*	6	3	19*	20	INH 37
OPS 0 7*	8	4	21*	22	
		PL 1/2	23*	24	IPL SOURCE SW MASK 38*
MMU STATUS		VAR PARAM ID LIST		G3 ARCHIVE	
1	RDY	25	951C	LOAD	48
2	RDY	26	2723	RETRIEVE	49*
MMU SOURCE/BUS		27	0F11	GROUND OPS	
GPC/MMU	9*	28	34D2	GSE POLL ENA	50
MMU/MMU	10	29	34D2	SM GSE INH	51
GPC/LDB	11	30	B6E0	SM C/O ENA	52
CKPT RETRV		31	B804	GNC C/O ENA	53
	ENA 12*	32	B805	BFC C/O ENA	54
RTC		33	CAE8	ALT PL9 TB	55
13	-----	34	2721		
CMD	I4				

4977. CRT# 3

Figure 3-13. SPEC 1 - DPS UTILITY display

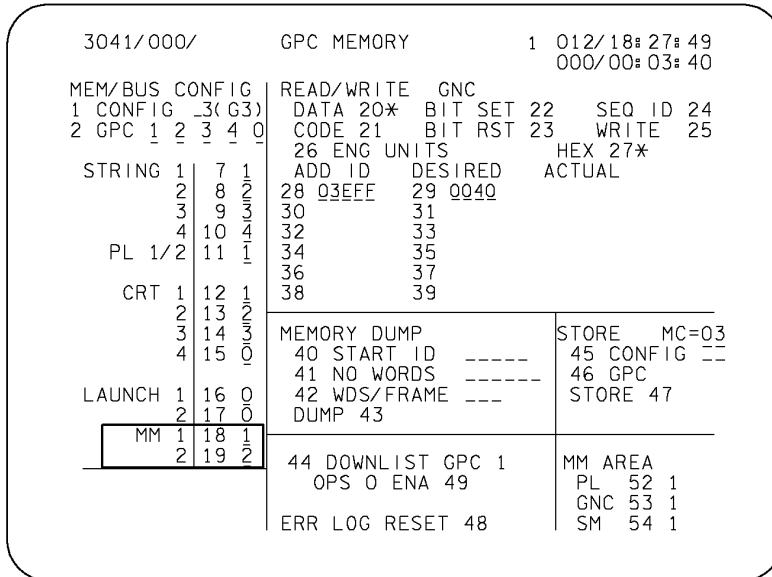

5223. CRT: 3

Figure 3-14. GPC MEMORY display

3.1.13 Memory Source Selection During Initial Program Load

During an IPL, a mass memory unit is selected as the software source via the IPL SOURCE switch on Panel O6 (Figure 3-15). This switch is a three-position toggle switch, which is either in the MMU 1 or MMU 2 position during the IPL sequence. At all other times, this switch is nominally in the OFF position. The MMU 1 and MMU 2 positions send a discrete input to each GPC, which reserves that MMU for the IPL'ing GPC. PASS software allows these discretes to be ignored (or masked) via DPS UTILITY, SPEC 1, item 38. This mask is normally active.

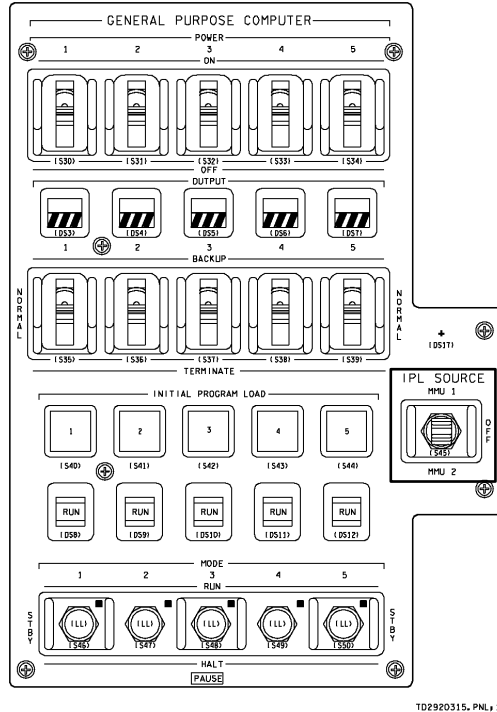

Figure 3-15. Panel O6

3.1.13.1 OPS Transitions

The controls for selecting the memory source for an OPS transition, and the bus over which it is loaded into the GPCs, are on SPEC 1 - DPS UTILITY (items 9 through 11) (Figure 3-16). The display is initialized with item 9 selected, which is almost always used. As part of the GPC status exchanged at CS sync, each GPC exchanges what its current resident memory configuration is. Then, when a request is made for a memory configuration, the software determines whether or not another GPC already has the requested OPS or a current major function overlay. If another GPC already has any of the requested software, the lowest numbered such GPC is used as a source for the other GPCs. Such a GPC-to-GPC overlay of software is done over the mass memory data buses. An overlay that is not available from a GPC is loaded from mass memory. Note that the major function overlay could come from another GPC and the OPS overlay from mass memory, for example.

If there is a problem with both of the mass memory data buses, or the MMUs do not indicate "RDY," then item 11 might be selected, if there is a GPC source for both overlays. In this case, the GPC-to-GPC overlay is done over the LDBs.

Memory reconfiguration may be forced from a mass memory, regardless of other GPC sources, by selection of item 10 on the DPS UTILITY display. In this case, whether both are required or not, both the major function overlay and the OPS overlay are loaded from mass memory. This is used only if the software in a current GPC is suspect for some reason.

If there is no usable GPC source and/or the selected MMU is OFF or being used for another memory transaction, the class 3 fault message MMUx OFF/BSY is initiated. The current status of each MMU is shown on the DPS UTILITY display as either RDY (ready to respond) or BSY (OFF or currently responding to a GPC command).

```

1041/001/          DPS UTILITY          2 012/18: 28: 08
                                000/00: 03: 23

MMU ASSIGN          PORT ASSIGN          UL CNTL
  1  2              PRI SEC              AUTO 35
GNC 1X 2          STRING 1 15X 16        ENA 36X
SM 3X 4           2 17X 18              INH 37
PL 5X 6           3 19X 20              IPL SOURCE SW
OPS 0 7X 8        4 21X 22              MASK 38X
                                PL 1/2 23X 24

MMU STATUS          VAR PARAM ID LIST
  1 RDY              25 951C
  2 RDY              26 2723
MMU SOURCE/BUS      27 OF11
GPC/MMU 9X          28 34D2
MMU/MMU 10         29 34D2
GPC/LDB 11         30 B6E0
                                31 B804
                                32 B805
                                33 CAE8
                                34 2721

CKPT RETRV          G3 ARCHIVE
  ENA 12X          LOAD 48
                                RETRIEVE 49X

RTC
13 _____
CMD 14 -----

GROUND OPS
GSE POLL ENA 50
SM GSE INH 51
SM C/O ENA 52
GNC C/O ENA 53
BFC C/O ENA 54
ALT PL9 TB 55

```

5226. CRT: 1

Figure 3-16. DPS UTILITY display

3.1.14 Checkpoint

Some of the data in the SM software are changed right before or during a flight. These include the caution and warning limits or annunciation inhibits for various parameters that can be modified via a ground uplink called a Table Maintenance Block Update (TMBU). If the SM GPC were lost, the new SM GPC software (loaded in from mass memory) would not contain these changes. Therefore, a method was devised to take a "snapshot" of all this data, called a checkpoint, which is written onto the mass memories for future use. It could then be loaded into a new SM GPC, if necessary.

SM checkpoints are taken periodically during a flight. The crew controls initiating checkpoints are on SPEC 60 - SM TABLE MAINT display (Figure 3-17). Execution of item 18 performs the checkpoint and the status of the checkpoint and its GMT are displayed next to it. Usually, a checkpoint is written onto both mass memories by selecting first item 4 on DPS UTILITY before initiating the checkpoint and then item 3 before initiating the second one. If an error occurs, an S60 CHECKPT FAIL fault message is annunciated.

```

2011/060/          SM TABLE MAINT          2 236/00:05:01
                                                000/01:30:00
PARAM
 1 ID 0470215
  VALUE=+58000.00↑
                LIMITS
      ALERT
      LOW      HI
2[+] 14000.00 3[+] 50000.00 11*[+] 12000.00 12[+] 57500.00
4[ ]          5[+] 52500.00
6[ ]          7[ ]
      8 FILTER 03
      ENA 9*
      INH 10
                BACKUP C&W
      LOW      HI
13 FILTER 03
      ENA 14*
      INH 15

CONSTANT
16 ID 0914123
17 VALUE=[+] 75541.0000

CHECKPT 236/00:05:00
INITIATE 18
STATUS GOOD

FDA
ENA 19*
INH 20

ITEM 18 EXEC

```

5225.CRT; 1

Figure 3-17. SPEC 60 - SM TABLE MAINT display**3.1.14.1 Checkpoint Retrieved**

To enable the retrieval of the checkpoint from mass memory by a new SM GPC, item 12, CKPT RETRV ENA on DPS UTILITY (Figure 3-18) is executed. An asterisk appears next to it. If the retrieval is enabled, the last checkpoint will be rolled in from the MMU selected via item 3 or 4 when a GPC is taken to SM OPS 2 or SM OPS 4 from OPS 0 by an OPS 201 (401) PRO. This is the only time a checkpoint can be retrieved. After a checkpoint has been retrieved during an OPS transition, the asterisk by item 12 will disappear and the capability will be inhibited, as it is initially, until reenabled by the crew.

```

1041/001/      DPS UTILITY      1 012/18:28:08
                                000/00:03:23
MMU ASSIGN      PORT ASSIGN
  1 2
GNC 1* 2      STRING 1 15* 16  UL CNTL
SM 3* 4        2 17* 18    AUTO 35
PL 5* 6        3 19* 20    ENA 36*
OPS 0 7* 8     4 21* 22    INH 37
                                PL 1/2 23* 24  IPL SOURCE SW
MMU STATUS      MASK 38*
  1 RDY
  2 RDY
VAR PARAM ID LIST
MMU SOURCE/BUS  25 951C
GPC/MMU 9*      26 2723
MMU/MMU 10      27 0F11
GPC/LDB 11      28 34D2
                29 34D2
                30 B6E0
                31 B804
                32 B805
                33 CAE8
                34 2721
CKPT RETRV      G3 ARCHIVE
  ENA 12*       LOAD 48
                RETRIEVE 49*
RTC
  13
CMD 14
GROUND OPS
GSE POLL ENA 50
SM GSE INH 51
SM C/O ENA 52
GNC C/O ENA 53
BFC C/O ENA 54
ALT PL9 TB 55

```

5226. CRT# 1

Figure 3-18. DPS UTILITY display

3.2 SYNCHRONIZATION AND GPC REDUNDANCY MANAGEMENT

Since the operation of the GPCs is critical to the safety and success of a shuttle flight, schemes were developed to have redundant computers operating together while performing checks on each other. These schemes are Sync and Redundancy Management (RM), which employ both hardware and software methods.

3.2.1 Common Set

All PASS GPCs in RUN are part of what is called the common set (unless they fail out of that set). The CS GPCs cyclically exchange certain status information (about six times a second) over the ICC data buses. The CS GPCs synchronize this exchange by sending out codes over three discrete sync lines that go out of and into each GPC. A PASS GPC attempts to join the CS and begin this exchange whenever it is moded to RUN. Of course, GPCs may be executing different applications software (as on orbit with GNC and SM GPCs) and still be operating as members of the CS. The information exchanged over the ICC data buses includes things necessary for proper DPS operation:

- Input/output errors
- Fault messages
- GPC failure status data
- IDP MAJOR FUNCTION switch settings

- GPC/CRT keyboard entries
- Resident memory configuration
- Memory configuration tables
- OPS overlay request
- MTU time
- Internal GPC time
- System level display information
- Uplink data
- State vector

3.2.2 Redundant Set

Due to the criticality involved in flying the vehicle, the GNC major function was designed to run simultaneously in multiple GPCs. GPCs running together in the same GNC OPS are part of the RS and they perform identical tasks using the same inputs and producing identical outputs. Therefore, any data bus assigned to a GNC GPC will be listened to by all members of the RS (except the IP buses since each GPC has only one dedicated bus connected to it). This includes all CRT inputs and MMU transactions, as well as FC data. In this way, if one or more of the GPCs in the RS fail, the others have all the data up to that moment and can continue operating the vehicle.

The RS maintains its sync in much the same way as the CS, but at a much faster and variable rate. The sync codes are sent out hundreds of times per second. (One difference, however, is that the ICC buses are used only if an I/O problem is detected.) The RS may be thought of as a subset of the CS since all of its members are also in the CS (but not vice versa). The RS is automatically formed (or changed, if needed) at GNC OPS transitions with multiple target GPCs and when target GPCs are added or deleted by legal OPS/mode recalls (also called set expansions or contractions). SM or PL GPC configurations must be simplex (in only one GPC at a time). Any attempt to have multiple GPCs perform an SM or PL OPS simultaneously will be refused by the software.

3.2.3 GPC Redundancy Management

Similarly to RM schemes maintained for other systems, the GPCs maintain an RM scheme to detect errors internal to the GPCs. These errors can include improper output of sync codes or ICC bus data by a particular GPC or detection of input errors that no other GPCs detect. For example, if a GPC misses two RS sync points in a row, the other GPCs vote it out of the RS. (That GPC could remain in the CS if it does not miss any of the much-less-frequent CS sync points.) Or, a GPC might have a problem with

its MIA for a particular data bus to which the set is listening. Since it would be the only GPC to detect an I/O error for that bus, it would fail itself out of the set in a process called a force-fail-to-sync. For all but the mass memory data buses, this would be a fail-to-sync with the entire CS. However, for this special case, if a RS GPC fails to correctly receive an OPS overlay (and the other RS GPCs receive it), that GPC will fail out of the RS only and remain in the CS (in OPS 0).

When there are only two GPCs in an RS or CS and a disagreement occurs, each GPC sets a fail vote against the other and the set splits into two simplex GPCs. In the case of an RS split, the crew or MCC would probably just assume the GPC with the most IMUs is the “good” one and run the failure procedures for the other former RS GPC, since it may be impossible to determine which really has the fault without further troubleshooting. It is important to note that a GPC that fails-to-sync does not stop processing software or outputting commands.

It will not listen to any data buses commanded by GPCs that are no longer in a set with it, but will still control any strings, CRTs, etc., that it was commanding at the time of the failure. That is why a failed GPC is taken to HALT or powered off as soon as possible, since its commands may be suspect. (Since the crew may not be able to reach the GPC switches during powered flight, this is called out in the procedures to be performed after Main Engine Cutoff (MECO) for a GPC failure during ascent.) Sometimes a GPC may have a more serious problem and actually halt all processing itself. This is indicated by a big “X” on its CRT(s) and barberpole MODE and OUTPUT tb’s on Panel O6.

3.2.4 GPC Fail Annunciations

GPC fail votes are annunciated in a number of ways. Each GPC has discrete output lines for fail votes that go to the other GPCs against each of the other GPCs. In addition, the hardware of each GPC echoes any fail votes it receives against itself from the other GPCs to the GPC status matrix or CAM. Also, a GPC fail detection causes a class 2 “GPC X **” fault message and a master alarm. Error indications are displayed on the GNC SYS SUMM 1 and GPC/BUS STATUS displays.

3.2.4.1 GPC STATUS Matrix (CAM)

The GPC STATUS matrix, commonly called CAM (since it used to be labeled the computer annunciation matrix), is a 5-by-5 matrix of lights located on Panel O1 (Figure 3-19). Each light corresponds to a GPC’s fail vote against another GPC or itself. For example, if GPC 2 sends out a fail vote against GPC 3, GPC 3 lights the second light down in the third column. Thus, the off-diagonal lights are votes against other GPCs and are white in color. The lights on the upper left to lower right diagonal are the self-fail votes and are yellow. Whenever a GPC receives two or more fail votes against it from other GPCs, its hardware lights its own diagonal light. It also resets any fail votes this GPC had against the other GPCs, so any off-diagonal lights in its row will be extinguished. Notice that a one-on-one RS or CS split gives no diagonal lights since there are not at least two GPCs voting against any given GPC.

Anytime a diagonal light on the CAM is lit, the GPC light on the C&W matrix on Panel F7 (Figure 3-20) also lights as indicated. Any fail vote discrettes driven by a GPC are reset by that GPC at GNC OPS transitions in which it participates. A GPC in STBY extinguishes its diagonal light (via software control) if the other GPCs' fail votes are reset. Fail votes can be reset by the crew via item 48, ERR LOG RESET, on SPEC 0 (Figure 3-21). However, this item also clears all the error logs for the GPCs in the major function assigned to the CRT on which the item entry is made. These are used by MCC personnel. Therefore, item 48 is "never" done without ground concurrence. Finally, whenever a GPC is powered off, all the CAM lights in its corresponding row and column are extinguished since it is that GPC's hardware that provides the signal power to drive its CAM column.

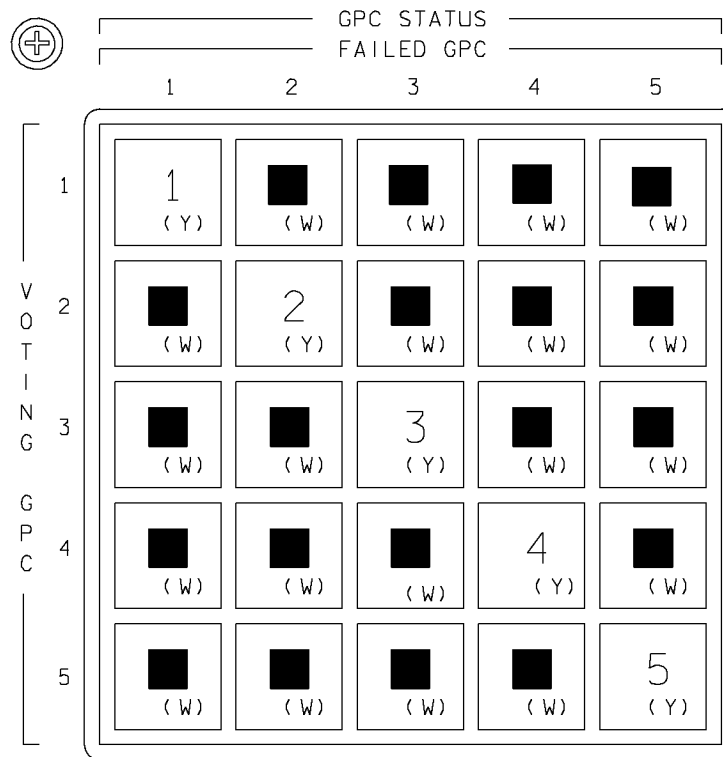

(XDS1)

TD2920319, PNL 1

Figure 3-19. Panel O1

O ₂ PRESS	H ₂ PRESS	FUEL CELL REAC (R)	FUEL CELL STACK TEMP	FUEL CELL PUMP
CABIN ATM (R)	O ₂ HEATER TEMP	MAIN BUS UNDERVOLT (R)	AC VOLTAGE	AC OVERLOAD
FREON LOOP	AV BAY/ CABIN AIR	IMU	FWD RCS (R)	RCS JET
H ₂ O LOOP	RGA/ACCEL	AIR DATA (R)	LEFT RCS (R)	RIGHT RCS (R)
————	LEFT RHC (R)	RIGHT/AFT RHC (R)	LEFT OMS (R)	RIGHT OMS (R)
PAYLOAD WARNING (R)	GPC	FCS (R) SATURATION	OMS KIT	OMS TVC (R)
PAYLOAD CAUTION	PRIMARY C/W	FCS CHANNEL	MPS (R)	————
BACKUP C/W ALARM (R)	APU TEMP	APU OVERSPEED	APU UNDERSPEED	HYD PRESS

(34V73A7A2)

TD2920320. PNL# 1

Figure 3-20. Panel F7

3041/000/	GPC MEMORY	O12/18: 27: 49
		000/00: 03: 40
MEM/BUS CONFIG	READ/WRITE GNC	
1 CONFIG _3(G3)	DATA 20* BIT SET 22 SEQ ID 24	
2 GPC 1 2 3 4 0	CODE 21 BIT RST 23 WRITE 25	
	26 ENG UNITS HEX 27*	
STRING 1 7 1	ADD ID DESIRED ACTUAL	
2 8 3	28 ----- 29 -----	
3 9 3	30 31	
4 10 4	32 33	
PL 1/2 11 1	34 35	
	36 37	
CRT 1 12 1	38 39	
2 13 3		
3 14 3	MEMORY DUMP	STORE MC=03
4 15 0	40 START ID -----	45 CONFIG --
	41 NO WORDS -----	46 GPC
LAUNCH 1 16 0	42 WDS/FRAME -----	STORE 47
2 17 0	DUMP 43	
MM 1 18 1		
2 19 2	44 DOWNLIST GPC 1	MM AREA
	OPS 0 ENA 49	PL 52 1
OPS 3 UPLK 50	ERR LOG REST 48	GNC 53 1
OPS 3 INIT 51		SM 54 1

5227. ART# 2

Figure 3-21. GPC MEMORY display

3.2.4.2 CRT Display Indications

The CAM lights are an instant indication of a GPC failure, but important information is also given on the CRT displays driven by the GPCs (both failed and in the set). The primary indications are the GPC fault messages, one for each GPC that is no longer in the set with the GPC commanding the CRT. These GPC fail messages differ from the CAM lights in that the failed GPC (if it is still able to drive a CRT) always annunciates fault messages against all the other GPCs and there is no self-fail fault message. There are no other CRT indications that correspond to the CAM lights, however. On GNC SYS SUMM 1 and GPC/BUS STATUS (Figure 3-22), there are columns for GPCs and strings. Each GPC drives a down arrow beside the GPC that has failed, including the failed GPC, if there are two votes against it.

		GPC/BUS STATUS				
1.0 1/ /006		1	2	3	4	5
		RUN	RUN	HALT	RUN	HALT
		G1	G1	G1	G1	0
STRING	1	FF FA *				
	2	FF FA ↓	* *	↓	↓	
	3	FF FA		* *		
	4	FF FA			* *	
PL	1	↓	↓	↓	↓	
	2	↓				
LAUNCH	1	*				
	2		*			
CRT	1	*				
	2	↓	*	↓	↓	
	3	↓		*	↓	
	4	↓	↓	↓	↓	

5228. CRT# 2

Figure 3-22. GPC/BUS STATUS display

Since any GPC in the set will stop listening to any buses commanded by the failed GPC (bus mask), down arrows are driven for those FCs as well as Missings (M's) for the LRUs affected on GNC SYS SMM 1 and/or down arrows for all buses commanded on GPC/BUS STATUS. If the GPC that has failed-to-sync is still running, it continues to command its assigned buses and masks all the other ones. Therefore, it drives down arrows and M's for the strings and buses commanded by all the other GPCs on its GNC SYS SUMM 1 and/or GPC/BUS STATUS displays. For example, suppose that GPC 2 fails to sync during ascent but continues to run. (Since all four PASS GPCs are in GNC OPS 1, the RS equals the CS.) Since GPC 2 has more than two votes against it, GPC 2's diagonal light on the CAM (Figure 3-23) is lit, along with the other lights in that column (except the GPC 5 vote). On any CRT displays driven by GPCs 1, 3, or 4 the fault message "GPC 2 * 1 3 4" appears along with down arrows and M's under GPC 2 and string 2 on GNC SYS SUMM (Figure 3-24) and GPC/BUS STATUS. GPC 2, however, annunciates three fault messages: GPC1 * 2, GPC3 * 2, and GPC4 * 2. It drives a down arrow for itself on its version of these same displays but has down arrows and M's for strings 1, 3, and 4.

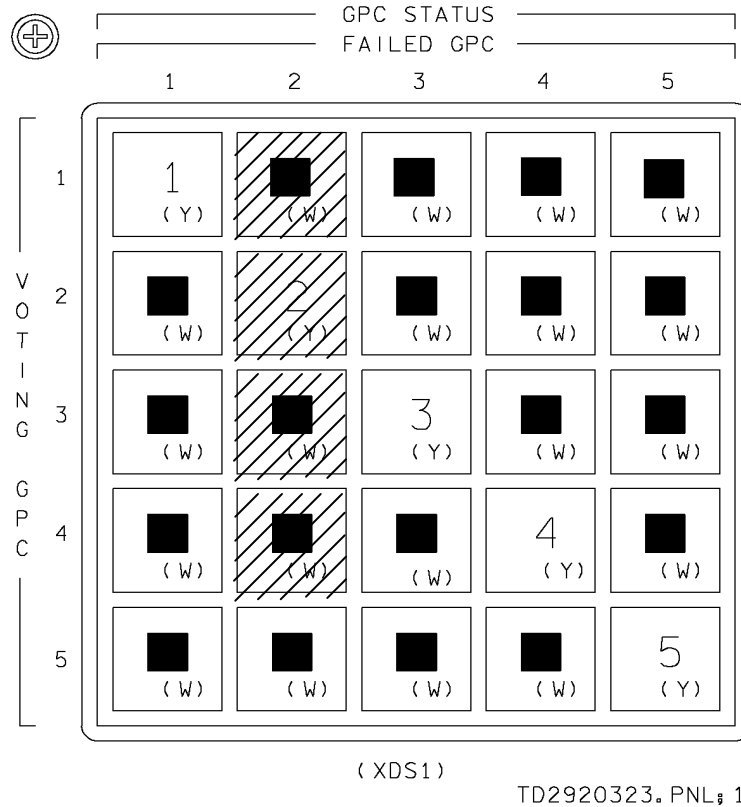

Figure 3-23. CAM

1041/	/O18	GNC SYS SUMM 1			1 000/00: 29: 11						
					000/00: 00: 00						
RCS	JETISOL	SURF		POS	MDM	DPS	1	2	3	4	5
MANFFAILV	LV										
F1	OP	L	OB			GPC		↓			
2	CLM	L	IB			MDM	FF	↓			
3	OP	R	IB			FA		↓			
4	CLM		OB								
5	CLM	A	IL								
L1	OP	R	UD			FCS	CH	1	2	3	4
2	CLM		SPD BRK						M		
3	CL		BDY FLP								
4	OP										
5	OP					NAV	1	2	3	4	
R1	OP					IMU		M			
2	CL					ACC		M			
3	CLM	CNTLR	1	2	3	RGA		M			
4	OP	RHC	L	M		TAC		M			
5	CLM		A	M		MLS		M			
		THC	L	M		ADTA		M			
			A	M							
		SBTC	L								
			R								
GPC		2	*	1	34	00: 28: 40					
SYS SUMM											

5229. CRT: 1

Figure 3-24. GNC SYS SUMM display

It should be pointed out that there are no pocket checklist or cue card procedures that help diagnose what kind of GPC failure has occurred. All these procedures assume that the crew has determined the nature of the GPC failures from the indications given.

3.2.5 GPC FAIL Procedures

The most important thing to do, after determining from the indications given which GPC has failed, is to get it to OFF or HALT in order to prevent it from sending out any spurious commands. This also allows the crew to give buses commanded by the failed GPC to good GPCs without having dual commanders result (since the failed GPC could not listen to the new assignments).

The FDF procedure for the example previously given is shown below. During powered flight, the crew refers to the DPS cue card, PASS GPC FAIL. After entering MM104, the crew moves on to the Ascent Pocket Checklist (Figure 3-25) under PASS GPC FAIL. The entry point into this procedure from the cue card is indicated by the arrow. The first step is to power off the failed GPC (assumes that the crew may not have been able to reach the GPC's MODE switch while strapped into the seats and under G forces). Step 2 ensures any remaining fuel is vented from the main engines. Steps 3 to 5 regain any control over OMS engine pointing that may have been lost. Step 6 has the crew perform a procedure to check for functions lost due to combinations of failures. If the failed GPC was driving a CRT, step 7 recovers it. Steps 8 and 9 apply only if the Abort Once Around (AOA) mode has been selected. If so, full recovery of any strings left uncommanded by the GPC failure would be highly desirable.

PASS GPC (1st FAIL)

- ⇒ 1. (Aff) GPC PWR – OFF
- ◇ 2. MPS PRPLT DUMP B/U LH2 VLV – OP
- If STRG 1(4) and performing burn in OPS 1:
- If GPC failed post–ET SEP:
- 3. MDM FF1(4) – OFF, ON
- 4. GNC 51 OVERRIDE
- Aff IMU – des
- 5. L(R) OMS GMBL – sel SEC
- 6. ✓ MULT DATA PATH LOSS, then:
- 7. Reassign IDPs as reqd
- If AOA, at MM301 trans:
- 8. (All) FCS CH – AUTO
- 9. Reassign aff string to highest # GPC

Figure 3-25. Ascent Pocket Checklist

For any on-orbit GPC failure, the basic procedures after securing the failed GPC are to get into a stable on-orbit configuration as soon as possible (Figure 3-26). For one GPC failed, this means having at least one G2 (all strings assigned to it), a SM, and a BFS GPC. Then the crew dumps the contents of the failed GPC to the ground (via hardware) for analysis, as well as doing a software dump of a good GPC for comparison and any record of synchronization errors. Once the dumps are completed, the crew can try to recover the failed GPC by performing an IPL on it. If the GPC is recovered, it can then be made the second G2 GPC. Further information on GPC dumps and recovery procedures will be provided later.

It is important to note that if no CRTs are being commanded by the CS, any GPC moded from STBY to RUN takes control of CRTs 1, 2, and 3. Thus, if a GPC, which is commanding all CRTs fails, the pocket checklist procedure has the crew mode the FD GPC to RUN via the "GNC Recovery VIA G2FD" procedure. It assumes command of the forward CRTs, which can then be assigned as desired. If there is no FD GPC, a running PASS GPC can be taken to STBY and back to RUN.

PASS GNC GPC (1st FAIL)

NOTE

If Group B(C) LOW LEVEL (MSN EXT) pwrdn
config, MMU 2 – ON

If no active GNC GPC and G2FD GPC available:

1. Go to GNC RECOVERY VIA G2FD >>

If no active GNC GPC and no FD GPC available:

2. Go to BFS ENGAGE >>

If failure is CS split and GPC config is 1 GNC and 1 SM:

3. Go to MAL, DPS, 5.1a, CS SPLIT 1 >>

If Dual G2 and RS split (CS intact) but both GPCs appear functional

(✓DPS & ADI displays, MODE tb):

4. Retain GPC with two IMUs

If Triple G2 and RS split but GPCs appear functional

(✓DPS & ADI displays, MODE tb):

5. Retain GPC with two strings

6. (Aff) GPC PWR – OFF

If FF 1 PWR cycled:

7. GNC 21 IMU ALIGN

IMU 1 (caged) – desel

8. Reassign failed GPC IDPs: GPC/CRT as reqd

If redundant GNC GPCs reqd and G2FD available:

9. (G2FD) ✓GPC MODE – HALT
 ✓OUTPUT – NORM
 ✓PWR – ON
 MODE – STBY (tb–RUN),RUN
10. IDP/CRTX MAJ FUNC – PL
11. GPC/CRT – (G2FD) GPC/X EXEC

If two GNC GPCs remaining:

12. Assign GNC GPC(s) strings, CRTs, and MMUs in current MC
(✓PL 1/2 and LB1 deassigned)
13. GNC, OPS XXX PRO
14. Go to step 22

15. GNC 0 GPC MEMORY

✓Downlist to active GNC GPC:

DOWNLIST GPC – ITEM 44 +X EXEC

If G2FD GPC available:

10. (G2FD) ✓GPC MODE – HALT
 ✓PWR – ON
 MODE – STBY (tb–RUN),RUN

If G2FD GPC not available and Triple G2:

11. Assign two GNC GPCs strings, CRTs, and MMUs in current
MC (✓PL 1/2 and LB1 deassigned). Do not change target
set
12. GNC, OPS XXX PRO

Figure 3-26. Orbit Pocket Checklist

3.2.6 Redundant Set Fail On Orbit

Suppose that on orbit GPC 4 is the SM GPC, GPCs 1 and 2 are in an RS executing GNC OPS2, and GPC 3 is in HALT and freeze-dried with GNC OPS 2. If GPC 1 fails RS sync with GPC 2 but not CS sync, it is still in the CS with GPCs 2 and 4.

Since GPC 1 is voting against GPC 2 and vice versa, neither has two fail votes against it. Therefore, neither GPC 1 nor 2 lights a self-fail diagonal light on the CAM matrix, as shown in Figure 3-27. Because the diagonal light is missing, the other indications usually triggered by that same discrete are also missing. These include the GPC light on F7, the GPC ↓ on GNC SYS SUMM 1 and the GPC/BUS STATUS display, the MASTER ALARM, and Backup (B/U) C&W light.

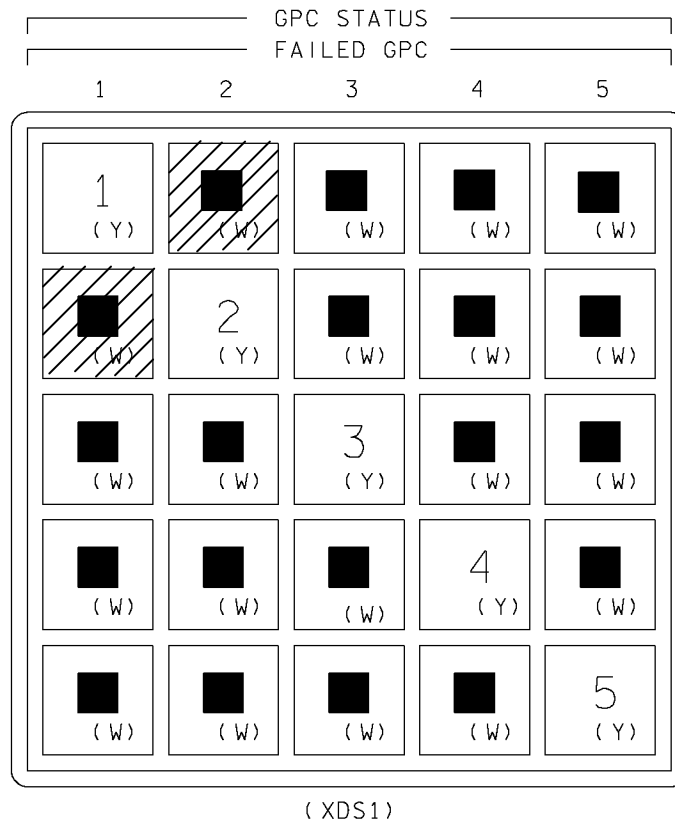

TD2920328. PNL# 1

Figure 3-27. Panel O1

GPC 1 and GPC 2 each mask the data buses commanded by the other. Hence, the GPC/BUS STATUS display should look the same from both GPC 1's and GPC 2's points of view as shown in Figure 3-28. (Remember, the GPC/BUS STATUS display is a CS level display [system software] and displays CS information.) The GNC SYS SUMM 1 display reflects the point of view of the GPC driving it (Figure 3-29 and Figure 3-30). The fault messages should read GPC2 * 1 and GPC1 * 2. Both messages appear on all CRTs since fault messages are exchanged among all the members of the CS.

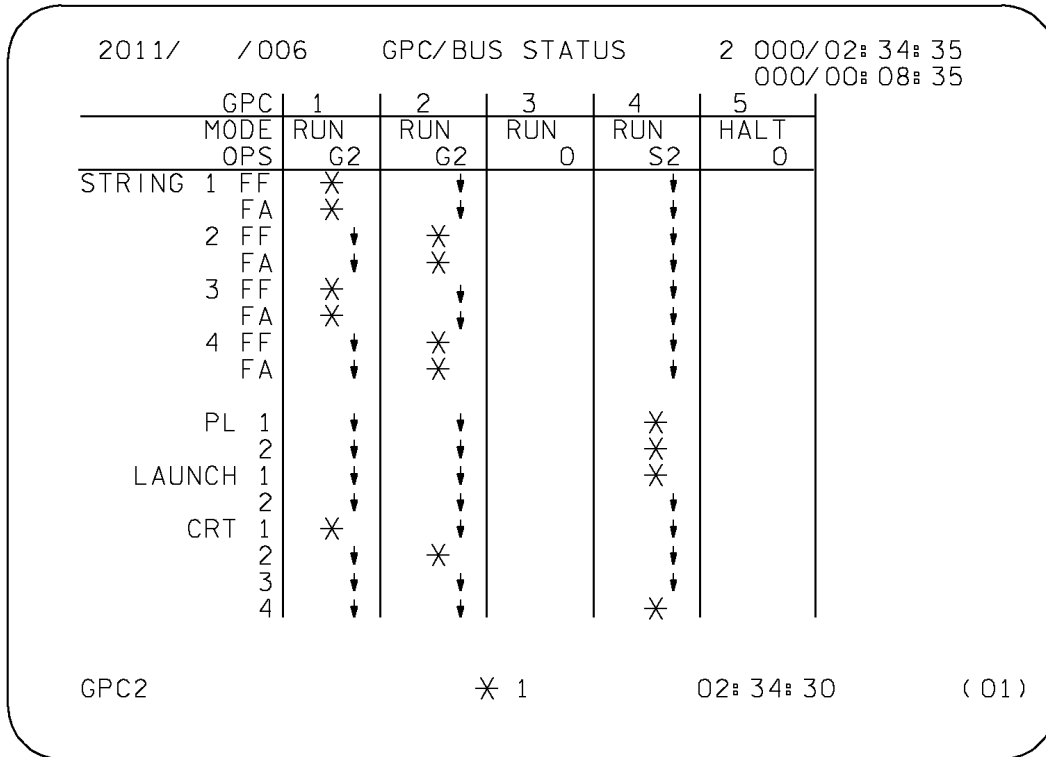

TD2920329. CRT; 2

Figure 3-28. GPC/BUS STATUS display

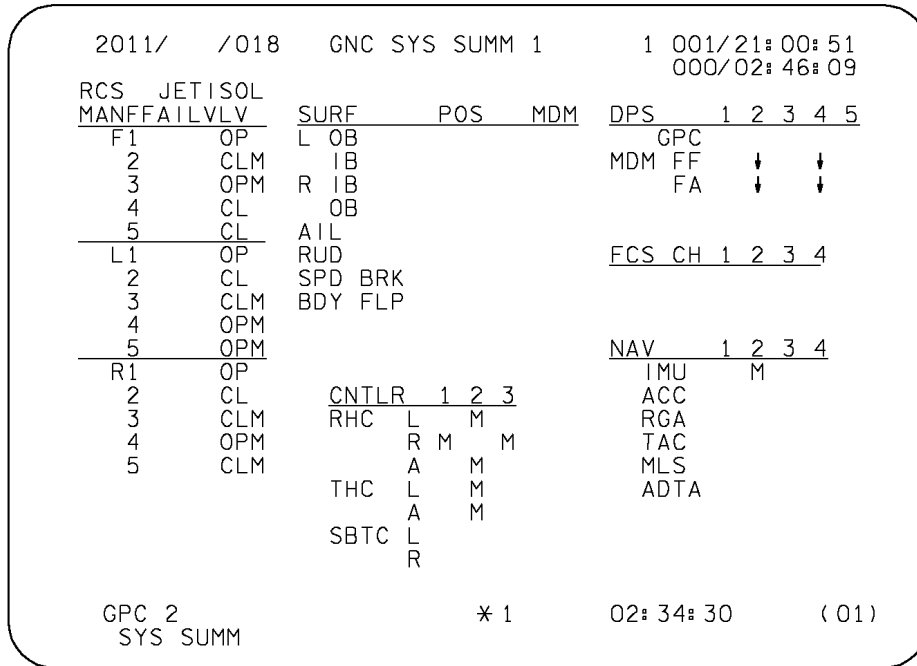

5231. CRT: 4

Figure 3-29. GPC 1 SYS SUMM display

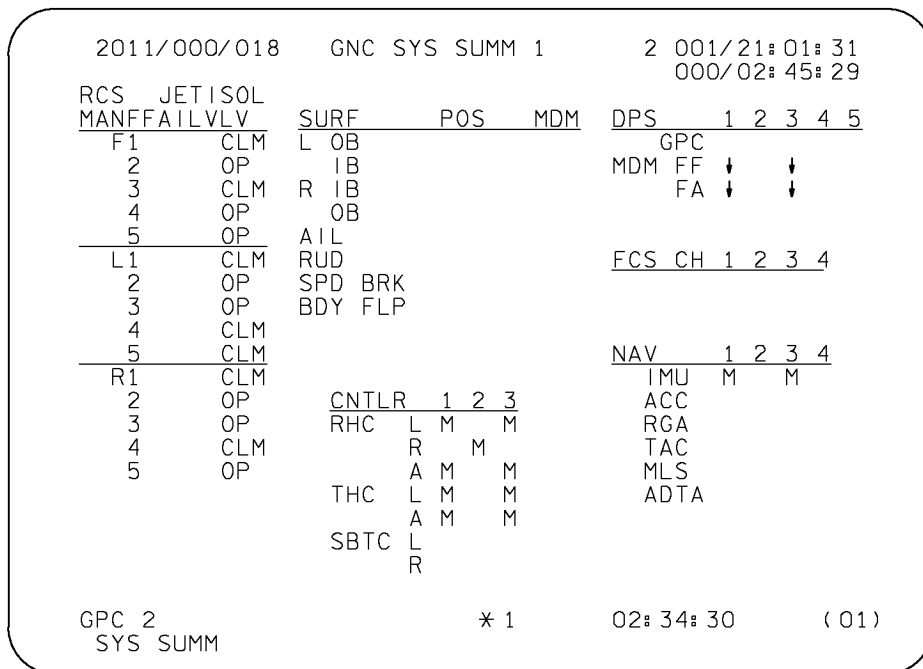

5232. CRT: 2

Figure 3-30. GPC 2 SYS SUMM display

3.2.7 Input/Output Management

One of the responsibilities of the system software is the management of the GPC input and output operations. This function includes assigning GPCs as commanders and listeners on the data buses, the logic involved in sending commands to these data buses at specified rates, and responding to requests from the applications software. Furthermore, the systems software I/O management function also includes the I/O error processing techniques and some special tests for certain failure conditions. This software also provides failure annunciation to the ground and to the flight crew if an I/O error is detected.

The I/O management logic, related to bus assignment and I/O error processing, varies somewhat between the various data bus groups. Therefore, these data bus groups and their associated I/O management logic will be discussed separately. Prior to doing this, however, we will examine the major concepts, which are basic to the entire subject of I/O management.

3.2.8 I/O Transaction

An I/O transaction is, essentially, an operation that is controlled by systems software for the initiation and the execution of a data transfer into, or out of, a GPC. This request can be based upon a request from the applications software or can come directly from the system software itself. This I/O transaction may involve multiple data buses connected to multiple Bus Terminal Units (BTUs), each of which is connected to multiple sensors or effectors.

In order to maintain consistently identical inputs for the RS GPCs, input transactions involving these RS GPCs are protected. This means that if two or more RS GPCs fail to correctly receive and process the input data, they all ignore the data. You should note that, typically, following the first detection of an input error, the transaction will be tried again in the next data cycle.

Special logic is incorporated to ensure that a single faulty GPC cannot prevent the other RS GPCs from receiving necessary data. If a GPC in the RS is the only RS GPC to detect the same I/O error two consecutive times, that GPC forces itself to fail-to-sync and, therefore, drops out of the RS and CS. Therefore, on ascent, if the GPC 2 MIA receiver fails on FC data bus 1, GPC 2 alone detects errors in transactions over this data bus and, as a result, force-fails-to-sync.

The protected transaction capability is maintained through the use of sync codes and certain I/O error processing techniques whereby, if any member of the RS detects an I/O error, that information is exchanged among all the RS GPCs. If more than one GPC detects an error then the GPCs together stop listening to that unit or element.

While protected transactions are used primarily for RS transactions, there is also one other case where the same philosophy is invoked: ICC transactions involving the CS. Here again, if more than one GPC in the CS detect an I/O error on an ICC transaction, this information is revealed to the other GPCs and no CS GPC uses the data that was received over the involved ICC bus. Also, the same logic applies here as in the other

protected transactions. If a single GPC detects two successive I/O errors on an ICC transaction while the rest of the GPCs do not, that GPC force-fails-to-sync.

Most I/O transactions are performed cyclically. Applications software processing that is critical to vehicle safety, such as GNC flight control, operates at a high cyclic rate (25 Hz is the fastest cycle). Other processes operate at slower rates. Not all I/O transactions are performed cyclically, however. Some transactions are initiated only upon a specific noncyclic request from the software.

An I/O transaction can consist of the acquisition of groups of data from several different LRUs over one data bus. Since the control of an I/O transaction over a particular data bus is performed by its BCE in the GPC, each (usually cyclic) set of instructions is called a BCE chain. BCE chains are composed of requests for data from several different LRUs and individual requests and the data acquired are called BCE chain elements or just BCE elements. (You may have noticed that we just spoke of a bus control element and this terminology is, unfortunately, confusing. Just remember that a BCE is a piece of hardware/software in the GPC and a BCE chain element is a small portion of an I/O transaction.)

3.2.9 I/O Error Handling

3.2.9.1 General Description

The I/O error handling logic is designed to detect data transmission errors. It is not designed to determine any other data validity. Data validity determination is the responsibility of the application software's redundancy management functions.

The specific way that I/O errors are handled is dependent upon the type of data bus involved. Some similar concepts exist, and they are discussed here. The specific I/O handling techniques for each of the data bus groups are discussed in the following subsections. In general, only input errors are detected and annunciated directly by the systems software. Therefore, we are primarily addressing the input error handling requirements here. Output problems cannot be easily detected by the GPCs since outputs are not reviewed by them.

Input errors can be detected at three basic levels. I/O error processing logic is invoked to determine if a detected problem is a result of a GPC, a BTU/MDM, or an individual hardware item (LRU) problem.

3.2.9.2 BCE Bypass

Validity checks are performed by the GPC on the format of the data in each transaction and an error can be identified to a particular BCE element. In this case, the GPC stops requesting and receiving data from a particular LRU (such as an IMU) or a certain set of elements (not every element can be bypassed individually). This type of error is called a BCE element bypass and is annunciated by an SM alert and a BCE STRG X message.

For example, if the -Z star tracker fails, the GPC recognizes that its portion of the I/O transaction is not correct and, if the error is detected twice in a row, it sets a BCE element bypass against that unit. This means that it no longer requests data from the star tracker. This is annunciated via a BCE STRG 1 STKR fault message (since the -Z star tracker data goes through MDM FF1 and string 1). The star tracker CRT display would also have M's and missing data for the -Z star tracker.

Suppose there is a problem with a particular card in an MDM. The GPC detects an error with one or more elements of a BCE chain. In this case, however, the GPC bypasses a specific set of inputs since it cannot bypass every element individually.

If the problem is in a single card involved in the "B" group of inputs from FF1, for example, then that whole set of inputs is bypassed and the fault message BCE STRG1 B is annunciated. For failures of this type, the crew performs the usual MDM recovery type actions; i.e., tries an I/O RESET EXEC, a port mode, and a power cycle of the MDM, as shown in the Ascent Pocket Checklist, Figure 3-31. The crew can then check the Reference Data Book (refer to Figure 3-32) for a list of the inputs lost.

BCE bypasses are defined for the FC and PL data buses.

BCE STRG X (no 'MDM OUTPUT' msg)

- If IMU:
1. **GNC 51 OVERRIDE**
(Aff) IMU(s) – desel
 2. I/O RESET
 - ◇ 3. If recovered: IMU – resel >>
 4. **GNC 1 DPS UTILITY**
(Aff) STRING – port mode
 5. If recovered: Go to step 9
 6. (Aff) MDM FF – OFF,ON
 7. I/O RESET; if recovered: Go to step 9
 8. **GNC 1 DPS UTILITY**
Orig ports – resel
 9. BFS I/O RESET
 - ◇ 10. If IMU recovered: **GNC 51 OVERRIDE**
(Aff) IMU(s) – resel >>
- If 'BCE STRG 3 NSP':
11. I/O RESET; if recovered >>
If msg repeats and LOS/no COMM:
 12. Go to COMM LOST (mult pnls), step 4 (**COMM**) >>
- If any other BCE BYP:
13. I/O RESET; if recovered: BFS I/O RESET >>
 14. **GNC 1 DPS UTILITY**
(Aff) STRING – port mode
 15. BFS I/O RESET; if recovered or if GPS >>
 - ⇒ 16. (Aff) MDM FA/FF – OFF,ON
 17. I/O RESET; if recovered:
BFS, GNC 51 OVERRIDE
If reqd: (aff) SURF feedback
RGA or AA – resel >>
 18. **GNC 1 DPS UTILITY**
Orig ports – resel
 19. BFS I/O RESET; if recovered >>
- If msg repeats and is BCE STRG B/C/D:
20. If BCE STRG 1D(4D): L(R) OMS – sel SEC GMBL
 21. If BCE STRG B: **BFS, GNC 51 OVERRIDE**
(Aff) AA – desel
 22. If BCE STRG D: **BFS, GNC 51 OVERRIDE**
(Aff) SURF feedback, RGA – desel
 23. If BCE STRG 2C: Go to MPS VACUUM INERT
(**MPS**)(9–3)

Figure 3-31. Ascent Pocket Checklist

FF1				
BCE	GPC INPUT		BCE	GPC INPUT
A	F RCS Ts & Ps MANF 1 P BFS QTY IMU 1 STATUS PNL F6 DISP SWs (eight)		ADTA IMU MLS MTU NSP STKR TAC	ADTA 1 IMU 1 MLS 1 MTU ACCUM 1 NSP 1 -Z S TRK TACAN 1 RADAR ALT 1
			GPC OUTPUT	
B	AA 1 F RCS MANF 1 JET RM L ADS DEPLOY DISC - A* RMG NO WOW - 1* CNTLRs/PBIs/SWs: AFT DAP CNTL - 3* RHC - 1* SENSE - 1* THC - 1* FCS CH 1 ORIDE - 2* 3 ORIDE - 2* 4 ORIDE - 3* ENTRY MODE - 1* FWD DAP AXES - A* CNTL - 1* THC - 1*		AA TEST ADTA 1 TEST F RCS He PRESS VLV A MANF 1 JETS IMU 1 L OMS GMBL PRI SEL MLS 1 TEST MTU UPDATE - 1* NWS 1 RADAR ALT 1 TEST TACAN 1 -Z S TRK DISPLAYS: C/W: L RCS (LK/TK P) FWD DAP LIGHTS L FCS MODE LIGHTS:	

Figure 3-32. Reference data

3.2.10 BTU Bypass

I/O to any BTU has to pass validity checks, and I/O to that special subset of BTUs we call MDMs is even more protected. If the response to a GPC from a BTU is just plain missing or is gibberish, then the error is set at the BTU level, avoiding multiple BCE bypass type messages. The message is, generally, of the form I/O ERROR XXX, where XXX is the BTU involved. This type of message is accompanied with an SM alert tone and light. For MDMs, the GPC sends a "return word" periodically with its requests for data, and the MDM copies it through several internal memory registers before returning it to the GPC with the requested data. The GPC then checks to see if this returned word is correct for the one it sent out. If the return word and data are both present, but the data are good and the return word is corrupted, then the GPC issues an MDM OUTPUT XXX message. This causes no bypasses (i.e., no M's or down arrows). Its purpose is to warn the crew that the MDM in question has some sort of internal problem which could potentially affect GPC commands out through the MDM, as well as input data coming in through the MDM. The crew should attempt the same type of recovery process as for any other MDM problem. (Remember that MDM OUTPUT XXX is not annunciated for enhanced MDMs.)

For example, if there is a problem with the primary MIA in FF1, the GPC detects that the problem is with the MDM itself and annunciates an I/O ERROR FF1 message and bypasses all inputs from that MDM. This is indicated by down arrows and M's on GNC SYS SUMM 1 (Figure 3-33) and GPC/BUS STATUS (Figure 3-34). The troubleshooting procedures for an MDM I/O error are similar to those for a BCE bypass: I/O RESET, port moding, and power cycle, when the problem is in the MDM, as directed in the Orbit Pocket Checklist (refer to Figure 3-35).

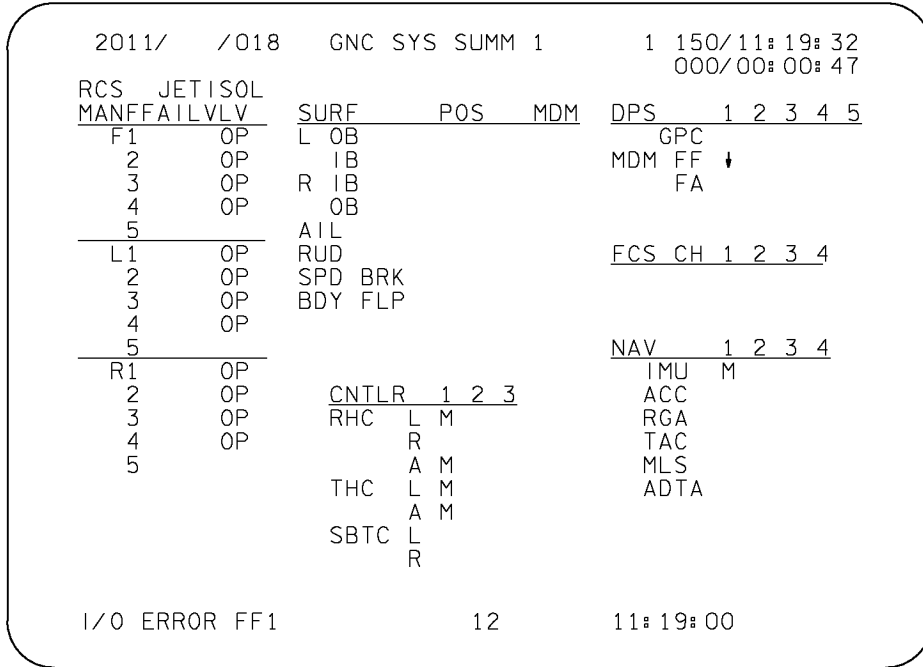

5233. CRT; 1

Figure 3-33. GNC SYS SUMM 1 display

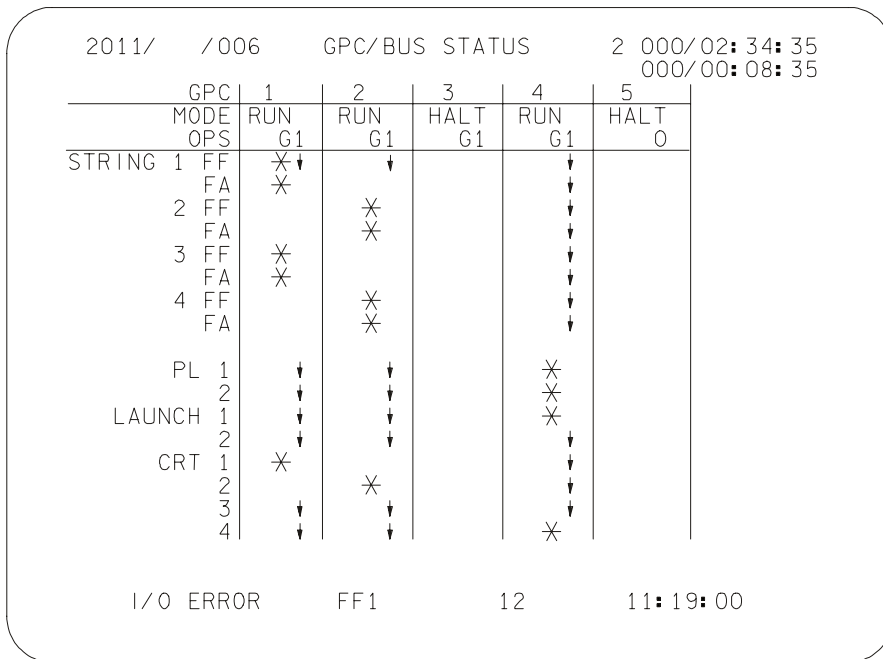

5234. CRT; 2

Figure 3-34. GPC/BUS STATUS display

FF(FA) MDM I/O ERROR

1. GNC I/O RESET, if recovered >>
 2. If OMS burn: Continue postburn
- If simo 'I/O ERR' msgs for mult MDMs (possible GPC problem):
3. ✓MCC/restring as reqd >>
 4. If FF: ✓ADI (aff string)
 5. If ADI 'OFF' flag (GPC problem): Go to step 15
 6. **GNC 1 DPS UTILITY** aff STRING – port mode
 7. If recovered >>
- If alt msg on aff string (GPC problem):
8. Go to step 15
- If any other:
9. (Aff) MDM – OFF,ON (FF: may cage IMU)
 10. GNC I/O RESET, if recovered >>
 11. If FF: **GNC 21 IMU ALIGN** aff IMU – desel
 12. Resel original ports
 13. If recovered: Resel IMU if desel >>
 14. If not: Go to MAL, **DPS**, 5.3 **1.1** >>
- If time permits, restring (with possible F–T–S):
15. Go to MAL, **DPS**, 5.3 **1.1** >>
- If not, sel desired FF/FA MDM:
16. **GNC 1 DPS UTILITY** port mode as reqd
- If FF MDM not chosen:
17. **GNC 21 IMU ALIGN** aff IMU – desel

Figure 3-35. Orbit Pocket Checklist**3.2.10.1 GPC Failure**

As described in the GPC RM section, there is special logic to determine whether an I/O problem is at the GPC level if multiple GPCs are involved in the transactions. These include all ICC bus inputs and RS input transactions for which the GPCs continually exchange their I/O error information. If only one GPC detects the same I/O error two consecutive times, it fails-to-sync (both CS sync and RS sync) with the other GPCs. If more than one GPC detects a particular I/O error two consecutive times, each GPC bypasses the BTU or BCE element as required.

For transactions involving a simplex GPC, no special logic is necessary to determine which GPC is responsible for detecting the error since only one GPC is involved. Following two consecutive I/O errors on the same transaction, the GPC does either a BTU or a BCE element bypass. (A simplex GPC cannot force-fail-to-sync for any I/O error, except an ICC bus transaction.)

Special I/O error handling checks exist to protect against certain hardware states and failures. For example, a specific test is made, following any I/O error, to ensure that only the assigned command GPC has its transmitters enabled. If another GPC transmitter is detected to be on, that GPC will force-fail-to-sync. A special test is also made following an FC MDM bypass to determine if the BFS has been engaged. If the BFS has been engaged, the PASS GNC GPCs go to software halt.

However, there is no way for software to tell if there is a problem with a GPC transmitter for a particular data bus when that transmitter is supposed to be on. Since the MDM affected does not receive any requests for data, it does not send any, and all the GPCs

listening to that bus agree that there was an I/O error with that MDM. One way for the crew to tell if a transmitter has failed off is to check the BFS, which listens for data (during ascent and entry only), detects the failure to transmit, and annunciates a BCE STRGX PASS fault message. Then the problem is identified to be at the GPC, and the crew can restring (if allowed under the Flight Rules).

If it is a FF MDM I/O error, the crew can also check whether the Attitude Direction Indicator (ADI) is still working. Since its commands go through the IDP (a totally different BTU), it still works if the problem was at the MDM. This step is listed in the Orbit Pocket Checklist, when BFS is not available (see again step 4 in Figure 3-35).

3.2.11 Bus Masking

Bus masking is a software controlled technique which results in a GPC terminating its command and/or listen mode on a given data bus. It is used when a bus is no longer controlled by a GPC within the set performing the transaction. For example, if on ascent GPC 3 fails-to-sync with GPCs 1, 2 and 4 (assuming the nominal string assignment on ascent - GPC 1/string 1, GPC 2/string 2, etc.), then GPCs 1, 2, and 4 mask FC buses 3 and 7 (string 3) which are commanded by GPC 3. Similarly, if GPC 3 is still processing software, it masks FCs 1 and 5, 2 and 6, and 4 and 8 (strings 1, 2, and 4), which are commanded by GPCs 1, 2, and 4, respectively. These indications can be seen on the respective SYS SUMM displays (Figure 3-36 and Figure 3-37).

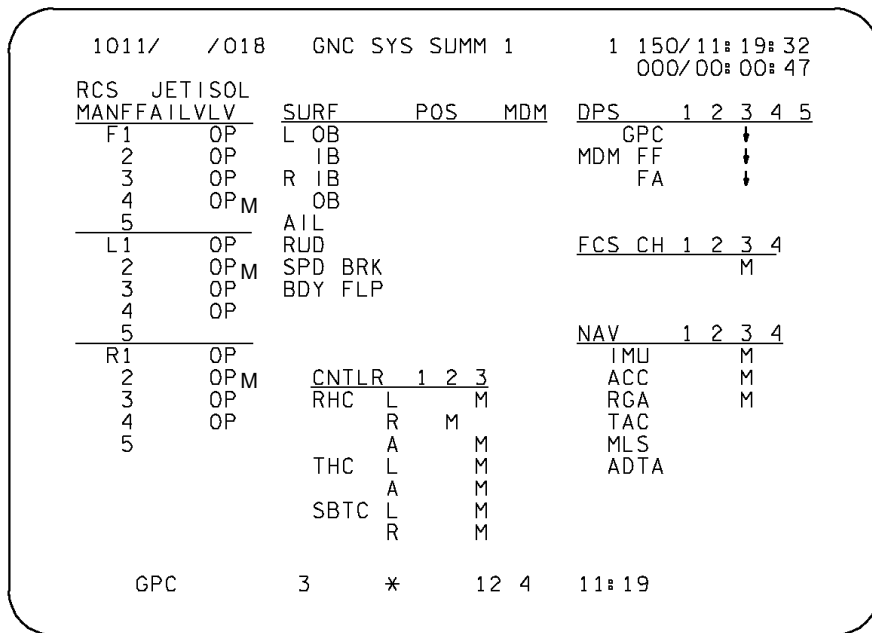

5235. CRT, 3

Figure 3-36. GPC 1 SYS SUMM display

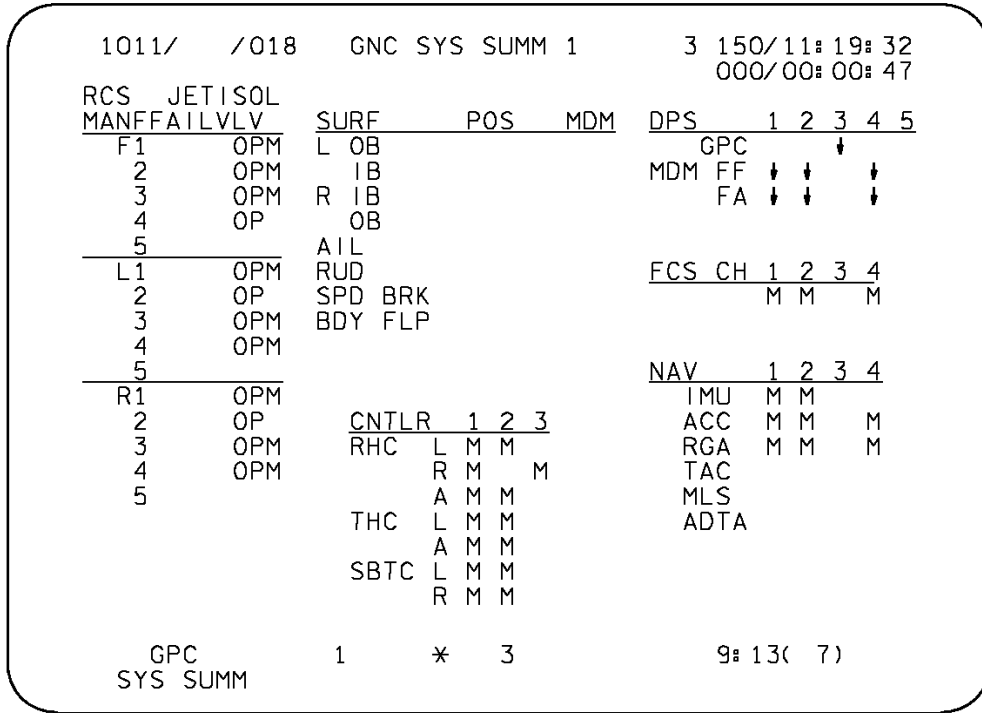

5236. CRT: 3

Figure 3-37. GPC 3 SYS SUMM display

Bus masks of this type are reset as appropriate, following a GPC being moded from HALT or STBY to RUN, following an OPS transition (which involves memory reconfiguration or RS formation), or following a legal OPS /mode recall in which memory reconfigurations or string reassignment is performed. Thus, in the previous example, if string 3 is reassigned to GPC 4, GPCs 1, 2, and 4 remove their bus masks on FC3 and 7.

Also, bus masks are normally set by system software when a GPC is required neither to transmit nor receive data on a particular data bus. For example, the GNC GPCs set bus masks on the PL data buses during the orbital flight phase when the PL buses are assigned to the SM GPC. The SM GPC does the same for the FCs (as shown on a nominal GPC/BUS STATUS display in Figure 3-38).

There is no special fault annunciation associated with bus masking except, in some cases, the use of M's or ↓s on the GPC/BUS STATUS and GNC SYS SUMM 1 displays to indicate missing data.

2011/ /006		GPC/BUS STATUS					2 000/02: 34: 35 000/00: 08: 35	
	GPC	1	2	3	4	5		
	MODE	RUN	RUN	HALT	RUN	HALT		
	OPS	G1	G1	G1	G1	0		
STRING	1 FF	*						
	FA	*						
	2 FF		*					
	FA		*					
	3 FF	*						
	FA	*						
	4 FF		*					
	FA		*					
	PL 1				*			
	2				*			
	LAUNCH 1				*			
	2							
	CRT 1	*						
	2		*					
	3							
	4				*			

5237. CRT; 2

Figure 3-38. GPC/BUS STATUS display

3.2.12 Resetting Comm Faults

All of the above types of errors are called commfaults (communication faults). Any time the GPC is no longer listening to a particular LRU, BTU, or data bus, a commfault is indicated via missing data on the appropriate CRT displays. The system software in the GPCs maintains a log of these I/O errors. This information is exchanged among the GPCs as well as being downlisted to the ground.

It is worth noting that a GPC that has commfaulted a BTU or LRU due to a failure at that BTU or LRU (i.e., the GPC is still in command of the bus in question) still outputs commands to it. The bus masking only affects inputs, since the purpose of masking is to ensure data integrity. The outputs are continued in the hope that the affected unit can still “hear” the GPC, even if it cannot respond to the GPC requests for data. An example of the usefulness of such an approach is failure of the transmitter at an FA MDM. If this happened, the MDM could still receive GPC commands to position the aerosurfaces even though it could not send its data to the GPC. While the crew could recover from the failure via port mode, the aerosurface commands are still getting through, and the hydraulic ports on the surfaces that are commanded through this FA MDM will not be “popped” (rendered useless until reset). Thus, when the MDM is recovered, the surfaces would work normally, without degradation.

There are various ways in which these bypasses can be reset and I/O restored if the problems are no longer there. All are major function dependent.

- a. A keyboard entry of I/O RESET EXEC tells the GPCs in the major function selected for that CRT/keyboard to try all transactions again. If power is restored or there was only a transient error causing a bypass of a particular element, normal I/O is resumed.
- b. OPS transactions and OPS/mode recalls involving memory reconfiguration, adding new GPCs, or reassigning buses also cause the GPCs to try an I/O RESET, automatically.
- c. Port moding causes an I/O RESET to be tried for everything on the moded string or PL buses but not on any other buses.

Not to be confused with an I/O RESET, only the error logs are cleared via item 48 - ERR LOG RESET - on SPEC 0 (Figure 3-39) (no I/O RESET is done). However, item 48 (which is also major function dependent) should not be done without a ground call since those error logs are used for troubleshooting.

3041/000/		GPC MEMORY		012/18: 27: 49	
				000/00: 03: 40	
MEM/BUS CONFIG		READ/WRITE	GNC		
1 CONFIG	_3(G3)	DATA 20*	BIT SET 22	SEQ ID 24	
2 GPC	1 2 3 4 0	CODE 21	BIT RST 23	WRITE 25	
		26 ENG UNITS		HEX 27*	
STRING	1 7 1	ADD ID	DESIRED	ACTUAL	
	2 8 2	28 -----	29 -----		
	3 9 3	30	31		
	4 10 4	32	33		
PL 1/2	11 1	34	35		
		36	37		
CRT	1 12 1	38	39		
	2 13 2				
	3 14 3				
	4 15 0				
LAUNCH	1 16 0	MEMORY DUMP		STORE MC=03	
	2 17 0	40 START ID -----		45 CONFIG --	
MM	1 18 1	41 NO WORDS -----		46 GPC	
	2 19 2	42 WDS/FRAME ---		STORE 47	
		DUMP 43			
OPS 3 UPLK 50		44 DOWNLIST GPC 1		MM AREA	
OPS 3 INIT 51		OPS 0 ENA 49		PL 52 1	
		ERR LOG RESET 48		GNC 53 1	
				SM 54 1	

5242. CRT, 4

Figure 3-39. GPC MEMORY display

3.2.13 Port Moding

As described in the hardware section, each of the FA, FF, and PL MDMs has two MIAs or ports. Each port is connected to a separate data bus so that there are two channels by which the GPCs can communicate with a MDM.

Each flight-critical data bus is connected to both a FF and FA MDM while both PL buses are connected to both PL MDMs. However, these buses can only interface with one MDM at a time. Port moding is the software method used to control which bus is used (i.e., which port of the MDM is “active,” see Figure 3-40). Port moding does not involve any hardware changes at all.

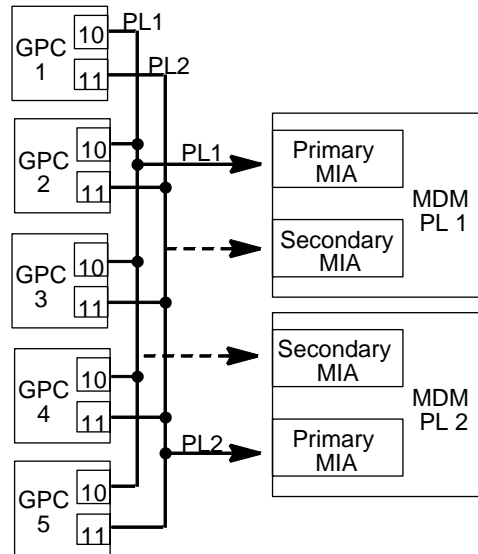

Primary mode

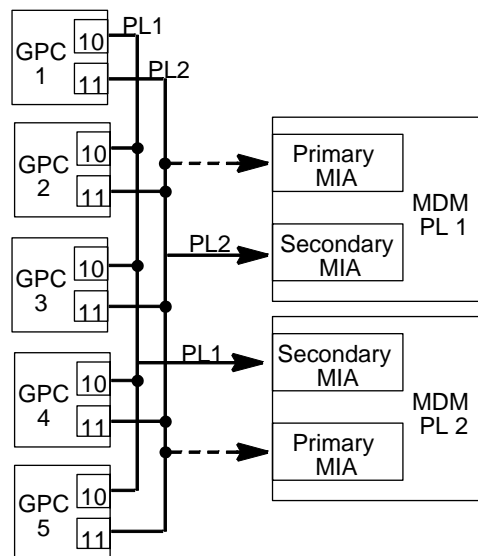

Secondary mode

td292_343

Figure 3-40. PL MDM primary and secondary modes

Initially, all buses are in the primary mode. If a failure occurs in a MDM, it may be related to a single port of the MDM; therefore, the crew would try the secondary ports. This is done via items 15 through 24 on SPEC 1 - DPS UTILITY. For example, an ITEM 16 EXEC would place string 1 in the secondary mode whereby FC1 would control FA1, and FC5 would control FF1 (see Figure 3-41). These changes take place immediately (no I/O RESET EXEC is required).

Since port moding always involves a pair of buses and “exchanging” which MDMs are accessed via each bus, both MDMs must be port moded at the same time. Also, it is important to remember that the control of all other BTUs connected to the affected buses is unaffected by port moding. That is, in the example given, control of the IDPs and HUD 1 is still via FC1, as shown in Figure 3-42.

The two launch data buses are also connected to dual ports in the LF, LA, LM, LL, and LR MDMs. Although there is no manual way to port mode these buses, an automatic switchover is done if an I/O error is detected on any of these MDMs during the prelaunch timeframe. A fault message would accompany any LF, LM, or LA MDM bypass. No message is annunciated for problems at the SRB (LL and LR) MDMs, although the MCC has visibility into such failures. There is no automatic port moding done for the SRB MDMs after liftoff.

```

1041/001/          DPS UTILITY          1 012/18: 28: 08
                                     000/00: 03: 23

MMU ASSIGN
  1  2
GNC 1* 2
SM  3* 4
PL  5* 6
OPS 0 7* 8

MMU STATUS
  1 RDY
  2 RDY

MMU SOURCE/BUS
GPC/MMU   9*
MMU/MMU  10
GPC/LDB   11

CKPT RETRV
      ENA 12*

RTC
 13 ----
CMD 14

PORT ASSIGN
      PRI SEC
STRING 1 15* 16
      2 17* 18
      3 19* 20
      4 21* 22
PL 1/2 23* 24

VAR PARAM ID LIST
 25 951C
 26 2723
 27 0F11
 28 34D2
 29 34D2
 30 B6E0
 31 B804
 32 B805
 33 CAE8
 34 2721

UL CNTL
AUTO 35
ENA 36*
INH 37

IPL SOURCE SW
MASK 38*

G3 ARCHIVE
LOAD      48
RETRIEVE 49*

GROUND OPS
GSE POLL ENA 50
SM GSE INH 51
SM C/O ENA 52
GNC C/O ENA 53
BFC C/O ENA 54
ALT PL9 TB 55

```

5240. CRT;3

Figure 3-41. DPS UTILITY display

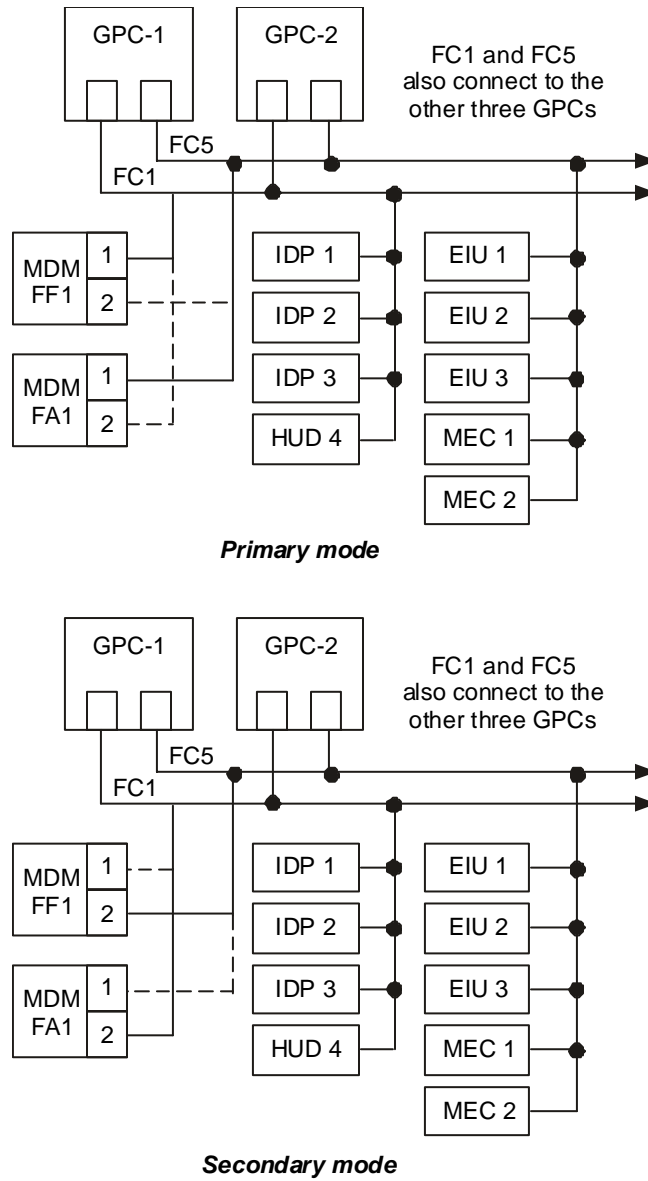

usa005350_002

Figure 3-42. String 1 primary and secondary modes

3.2.14 Mass Memory I/O Management

3.2.14.1 OPS Transitions Using the MMUs

During an OPS transition (or freeze-dry load process), if any of the GPCs involved detects an I/O error on the MM data bus selected (whether the overlay is coming from the MMU or another GPC), the class 3 fault message I/O ERROR MMUx is generated, and the software automatically retries the transaction. This retry serves to filter MMU and MM data bus transients. If the error occurs again, the class 3 alarm and fault message I/O ERROR MMUx is generated, and the software automatically retries the transaction on the other MM data bus. An automatic reassignment of this new MMU to the appropriate major function occurs, and this reassignment is reflected on the portion of the DPS UTILITY display that relates to MMU assignment (items 1 to 8) (Figure 3-43). This automatic switching protects against a single MMU or MM bus failure. If the error occurs again, the transaction is once again retried.

Any GNC GPC that detects an error on the second try on the second MM bus (and the other GPCs are successful) fails-to-sync with the successful redundant set GPCs and enters the OPS 0 state, remaining in the CS. An I/O ERROR MMUx error message is generated, with only the "bad" GPC(s) detecting, and the successful GPCs process the overlay. If all target GPCs detect an error, they do not process the overlay, are forced to OPS 0, and drive the GPC MEMORY display on the CRT on which the OPS XXX PRO was entered.

To save time in case a switchover is necessary, both MMUs are commanded to pre-position their tapes to the proper point. (Note that the freeze-dry process does not pre-position the MMUs.) If this vehicle is equipped with solid state mass memories, the pre-position commands are not useful to the SSMMs and are ignored. If either MMU does not indicate RDY, the fault message OFF/BSY MMUx is annunciated (once for each "bad" MMU). Again, if the first MMU indicates OFF/BSY when the GPCs attempt to load the new OPS, the OPS transition is automatically tried on the other MMU.

Also note that automatic retry is employed when using the GPC/LDB option. This protects against a LDB MIA or bus failure.

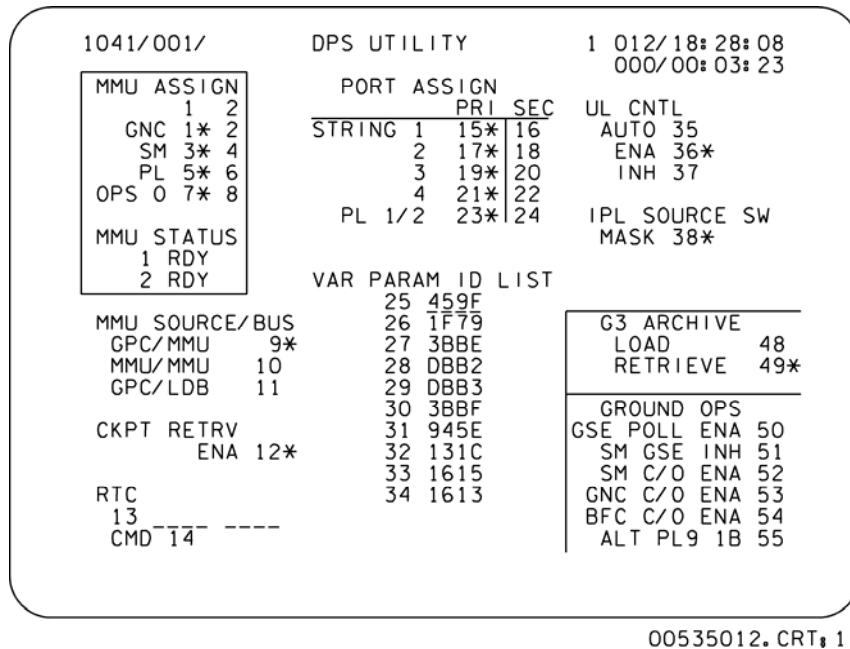

Figure 3-43. DPS UTILITY display

At this point, it is also good to remember that OPS transitions to GNC OPS 3 do not normally use the MMUs. Since the PASS GPCs have a copy of G3 in their upper memories (G3 archive), these copies are accessed for transitions to OPS 3 vs. accessing the MMUs. However, if it became necessary to engage the BFS during ascent, then the PASS GPCs are recovered via IPL during the on-orbit timeframe. IPL destroys the G3 archive in each GPC. Thus, a transition to G3 with the recovered PASS GPCs accesses the MMUs since the software knows there are no valid G3 archives.

3.2.14.2 Other MMU Transactions

For all other I/O transactions involving the MM data buses, there is no automatic switchover to the other bus in case of a failure on the selected one. For example, if the crew requests a SM roll-in spec and the transaction does not complete on MMU 1, the message MM PAGE NOT RETRIEVED is displayed on the screen. The crew then has to manually select the other MMU via item 4 on SPEC 1 and try to call the spec again.

3.2.15 Display Electronics Unit/Keyboard Data Bus I/O Management

3.2.15.1 DK Assignment

There are four Display Electronics Unit/Keyboard (DK) data buses (one for each IDP) connected to each of the five GPCs. Which GPC is in command of a particular data bus is a function of several factors: the current major function switch setting of the associated IDP, the nominal bus assignment table for the current memory configurations, GPC/CRT keyboard entries, and the position of the BFC CRT switches.

For the PASS, the MAJ FUNC switch (Figure 3-44) is used in connection with the NBAT (Figure 3-45) to specify which PASS GPC commands a given IDP. When the switch is

moved to a particular major function, the GPC currently in control of that IDP transfers control to the GPC specified for that IDP (CRT) in the active NBAT for that major function. If no GPC is specified for that IDP, the lowest numbered GPC in that major function assumes control. If no GPC in the CS is currently in that major function, the current commander retains control and displays the OPS 0 display. Upon OPS transitions, the above major function switch logic is also invoked, with the exception that IDPs not being commanded by the CS continue to be uncommanded. (GPC/CRT key input is necessary to assign an IDP to the CS. It is generally not possible to add or drop an IDP simply by virtue of performing an OPS transition.)

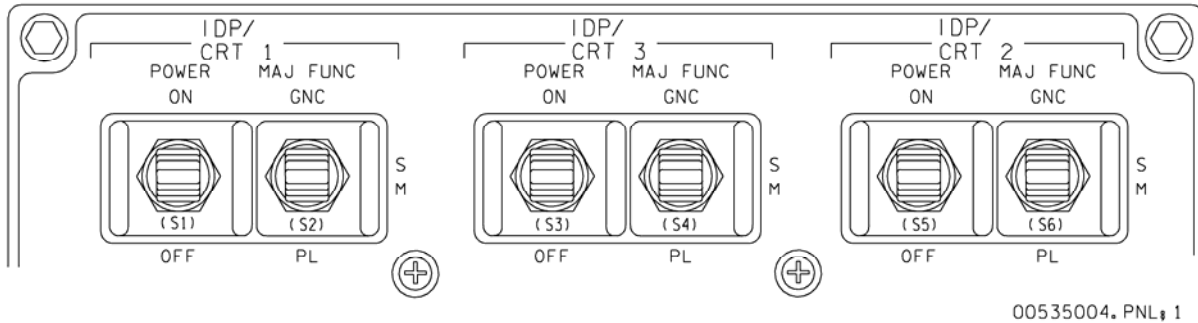
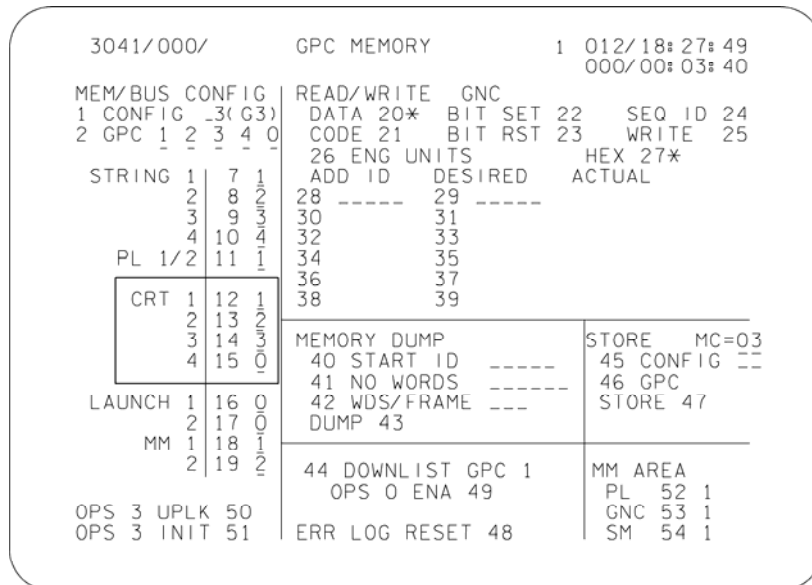

Figure 3-44. Panel C2



00535005. CRT: 1

Figure 3-45. GPC MEMORY display

The GPC/CRT key (Figure 3-46) is also used to reassign DK buses between the PASS and BFS GPCs. Following a GPC/CRT key input, the software automatically tries to transfer control of the IDP to the requested GPC. If the requested GPC is not in the CS (if PASS) or in HALT (if BFS), then the IDP is uncommanded. If the requested GPC is in the CS or is listening to the input, it assumes control of the IDP. (Whenever it is active, the BFS always monitors all four DK buses.) It then checks the MAJ FUNC (MF)

switch setting and, if it is not in the indicated major function, it invokes the above-mentioned MF switch logic. Also, no check is made to ensure against multiple commanders on the same DK bus if assignment of a CRT, which has a commander not in the CS is requested. (Dual commanders on a CRT are readily apparent: the CRT MDU flashes different backgrounds. Dual commanders should be avoided, as it can result in PASS GPCs failing-to-sync.)

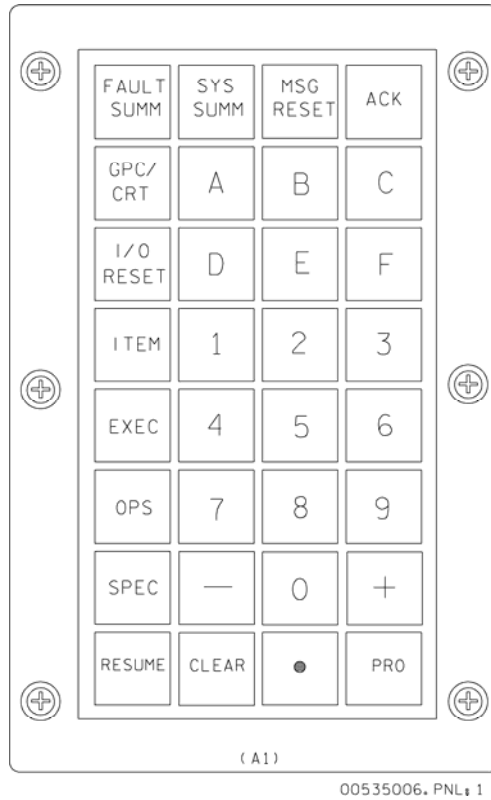

Figure 3-46. Keyboard

The BFC CRT switches (Figure 3-47) are the usual way to transfer control of the CRTs between the PASS and BFS. When the BFS is not engaged and the BFC CRT DISPLAY switch is ON, the BFS commands the first of the IDPs indicated by the position of the SELECT switch. Upon engage, the BFS automatically assumes control of the second IDP indicated as well.

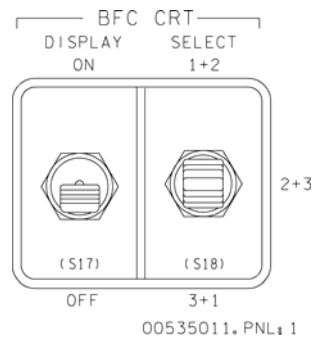

Figure 3-47. Panel C3

Finally, any PASS GPC moded to RUN automatically takes control of IDPs 1 to 3 if no DK buses are being commanded by the CS, as in the case of the first GPC to be IPL'd or activation of the freeze-dry GPC after failure of most or all of the other GPCs.

Changes in IDP assignment are reflected on the GPC/BUS STATUS display.

It is important to note that the PASS GPCs can only control three IDPs at a time (although the BFS can control all four). An attempt to assign a fourth IDP to the PASS results in a ">3 DEU" fault message. To get a new IDP, one of the original three has to be deassigned with a GPC/CRT 0X EXEC.

3.2.15.2 Error Handling

There are several levels at which errors can be detected. The IDPs themselves detect syntax errors in keyboard inputs (e.g., OPS PRO) and annunciate ERR on the scratch pad line without interfacing with the GPC. Keyboard inputs that are syntactically correct may be rejected as invalid by the GPC with an ILLEGAL ENTRY fault message if they are improper for the SPEC currently on that CRT MDU.

There are also checks on I/O between the IDP and GPC commanding it. Data transmission errors are annunciated (similar to other BTUs) with an I/O ERROR CRT X fault message. A difference for these types of errors for IDPs is that the GPC continues to try to communicate with the IDP; i.e., no I/O reset is needed even after assigning another GPC to that IDP with the GPC/CRT key.

Other indications of loss of communication between the IDP and GPC are the big "X" and POLL FAIL (Figure 3-48). Big "X" appears when the IDP does not receive display update data for 3 seconds. POLL FAIL appears in the lower right-hand corner when the IDP does not receive poll or time update commands for 3 seconds. Although they normally serve to indicate a problem, both of these are also displayed whenever a powered IDP is not assigned to any GPC (not a failure indication).

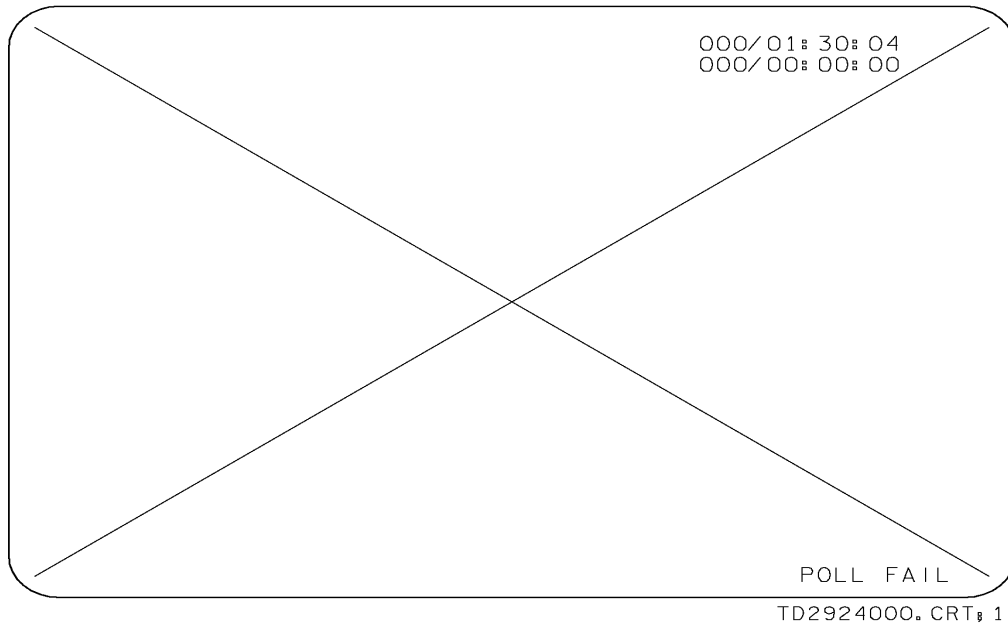

Figure 3-48. Big “X” POLL FAIL

3.2.15.3 BITE

Nearly all of the DPS hardware has BITE error indications, which are downlisted to the ground, but IDPs are the only units for which the crew has insight into BITE status. This visibility takes the form of hexadecimal words displayed on the MEDS MAINT display. There are also commands for the crew to command a MEDS LRU to perform a Comprehensive Self-Test (CST) and display fresh results on MEDS MAINT.

3.3 TIME MANAGEMENT

There is a system level SPEC, SPEC 2 - TIME (Figure 3-49), which provides the capability for the user to observe the current MTU and GPC clock status, synchronize or update the MTU and GPC clocks, select MET or GMT as the CRT mission time, and set CRT timers and alert tone duration/timers. The TIME SPEC is available in all major functions except GNC OPS 1, 3, and 6.

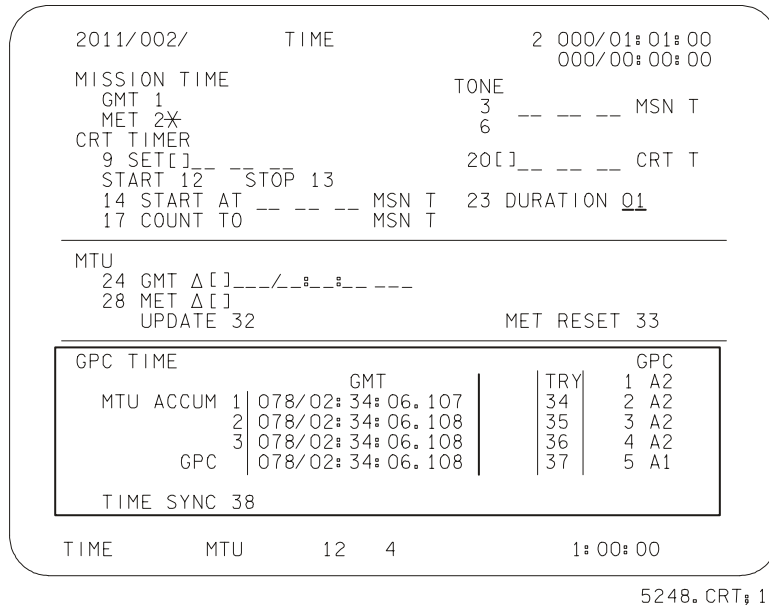

Figure 3-49. SPEC 2 - TIME display

3.3.1 GPC Time Source Selection

The three MTU accumulators keep track of the current GMT and MET (time since liftoff) by using the outputs of one of the oscillators in the MTU. The accumulators provide these times to the GPCs through MDMs FF1, FF2, and FF3. The GPCs each maintain their own internal time for comparison. Since all this information is shared over the ICC buses, each of the four CS GPCs has up to seven time sources available.

The GPCs start off using accumulator 1 as their time source. Each GPC cyclically checks the accumulator time against its own internal time. If it is within tolerance (limit is 0.8 millisecond), the GPC updates its internal clock to the time of the accumulator (which is more accurate) and continues to use that. However, if it is out of tolerance, the GPC tries the other accumulators and then the lowest numbered GPC time (limit is 5 milliseconds), until it has a successful comparison.

The GMT of each accumulator and the selected GPC are displayed near the bottom of the TIME display, SPEC 2. Any time source that fails the comparison has a down arrow next to it. If an I/O error causes data loss from an accumulator, the space for the time is blanked and an "M" is displayed there. At the far right is displayed the actual source each GPC is using for GMT. Any time a GPC is forced to switch to another accumulator or a GPC because the former source is bad or missing, the fault message TIME MTU is driven with an SM alert (Figure 3-49).

Items 34 to 37 on this display cause all the GPCs in the common set to try to use a particular accumulator or the selected GPC as their time source. If, for example, FF1 is lost, the GPCs downmode to accumulator 2 and annunciate a TIME MTU fault message. After recovery of FF1, the crew might want to get back on accumulator 1. Execution of item 34 accomplishes this if the accumulator can now pass the comparison.

Item 38 is used to synchronize the three accumulators to the time source currently selected by the lowest-numbered GPC in control of an accumulator (FC buses 1 to 3). All time values would be set equal to that source, and the GPCs would then try to use accumulator 1.

3.3.2 Time Update

It is possible to update the GMT and/or the MET clocks in the MTU and in the GPCs by entering a delta time update via user entry to the TIME SPEC (Figure 3-50). The MET may also be updated via the applications software. This is done at liftoff when the MET clocks are automatically set to zero.

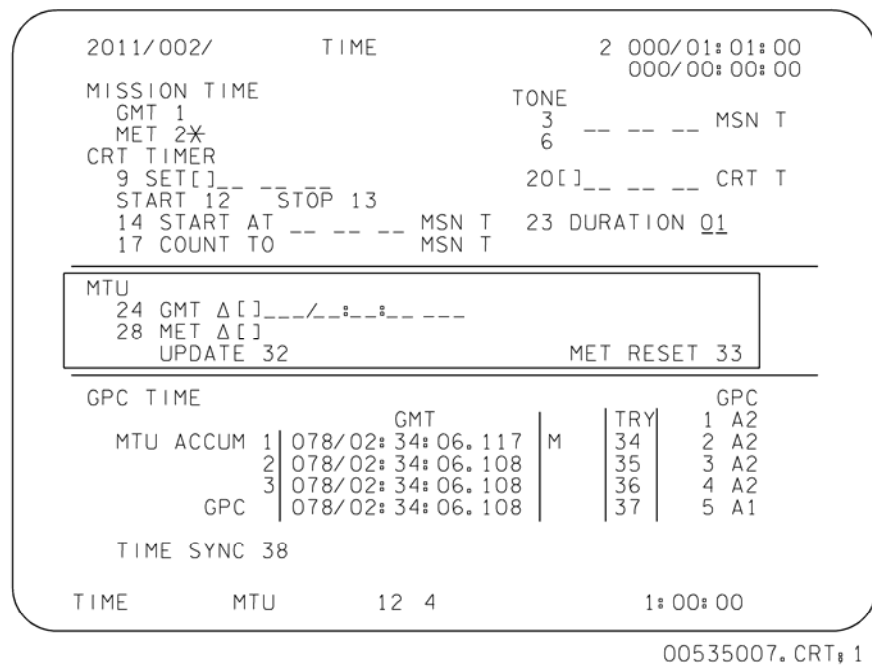

Figure 3-50. TIME display

Items 24 to 27 (25 to 27 are implied item numbers) on the TIME SPEC allow for user entry of a desired GMT delta update in day, hours, minutes, seconds, and milliseconds. Similarly, items 28 to 31 allow for a user entry of a desired MET delta update. An update can add to or subtract from the current time, depending on the sign (+ or -) of the delimiter for the first nonzero item entry. Remember that when an update is performed the delta time is input, not the desired new time. As with all items on this display, leading zeroes need not be entered.

Execution of item 32 actually initiates the time update using the values in items 24 to 31, which go blank at this point. However, the actual update does not occur until the second whole minute point after the item entry. During this 1- to 2-minute period, no I/O resets or time source reselection should be performed.

The only time a GMT update is performed is when the ground sees the whole system drift off the actual time. The maximum value for such a GMT update is 15 milliseconds and an ILLEGAL ENTRY is annunciated if a bigger delta is attempted. Since each PASS GPC bases its processing on its internal GMT runtime, this limitation ensures that no GPC goes inactive for more than 15 msec. (An exception to this limitation occurs when an update is made to the only GPC in the CS and that GPC is in OPS 0. In such a case, the GMT may be updated by days, hours, minutes, seconds, and milliseconds, and the MET is reset to zero.) Note that all the accumulators and the GPC get the update and accumulator 1 is then selected automatically.

Although the accumulators provide both GMT and MET to the GPCs, the PASS GPCs use only the GMT. They compute their own MET by subtracting the GMT of their MET starting point (nominally liftoff) from the current GMT. Therefore, a GMT update will also update MET.

Since MET can be made to count from any point, there is no limit on the amount of a MET change.

A MET update has no effect on GMT.

There is also a capability to manually reset the MET in both the MTU and the CS GPCs to zero. This is done via execution of item 33, MET RESET.

3.3.3 CRT Timers

In the upper right corner of every CRT display are two times. The first line is the mission timer. It usually displays MET but can also be selected to display GMT as mission time. Items 1 and 2 on the TIME SPEC control which time is displayed on all CRTs controlled by the CS. An asterisk indicates which time is selected.

Each major function is provided a separate CRT timer. This timer's current value is displayed on the second line of all displays in a given major function. This timer can be set to count up to or down from any value and to have different times for each major function by using the TIME SPEC on various IDPs (CS information).

A specified time can be placed in the CRT timer by using item entry controls on the TIME SPEC. This entry can be positive or negative, and can include hours, minutes, and seconds. Items 9 to 11 are used to specify this data, and, once again, the sign of the first entered nonzero item number defines the sign of the entire time string. A minus entry here, when started, causes the CRT timer to count down to zero and then begin counting up (the usual). A positive entry simply counts up from the entered value (rarely done). This CRT timer value is loaded into the timer, and the timer can then be started by an entry of ITEM 12 EXEC, at which time the data entered in items 9 to 11 go blank.

Another method of starting the CRT timer is to enter a mission time value in hours, minutes, and seconds, into items 14 to 16. This time is then compared with the value of the current mission time. When these two items are equal, the previously loaded time in

items 9 to 11 are loaded into the CRT timer, items 9 to 11 and items 14 to 16 go blank, and the timer begins counting.

There are also ways to have the CRT timer count down to a specific mission time. One method is via the TIME SPEC.

This is done by entering the target mission time into items 17, 18, and 19. Upon completion of this command sequence (depression of the EXEC key), the difference between the target mission time and the current mission time is loaded into the CRT timer, and the timer begins counting down. The CRT timer reaches zero when the current mission time and the target time are equal. When this happens, the data fields for items 17 to 19 go blank. Note that mission time is either MET or GMT as selected in item 1 or 2.

Note that for the CRT timer controls, days cannot be specified so times can only be set within 24 hours of the start or stop time.

For all cases involving the CRT timer, the timer may be stopped and set to zero using an ITEM 13 EXEC keyboard command. Also, whenever the CRT timer is required to count down to zero, it starts counting up again as soon as the zero point is reached.

Note that a separate CRT timer is available in each major function, so you may set up one timer in GNC and different ones in the SM and PL major functions.

The TIME SPEC is not the only display, which can control the CRT timer. The other one is the MNVR display (Figure 3-51). On this display, the Time of Ignition (TIG) of a burn can be entered using items 10 to 13 and loaded into the appropriate GPCs for execution using item 22. When the timer is started (ITEM 23 EXEC), the difference between the TIG and the current mission time appears in the CRT timer on all GNC CRTs; the CRT timer begins counting down, reaching zero at the time of burn ignition, and counting up thereafter.

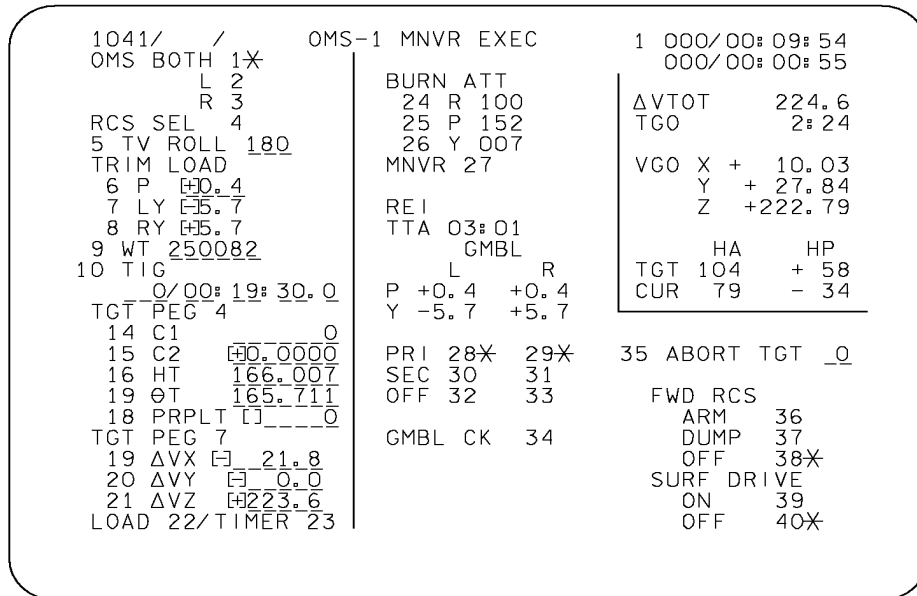

5250. ART: 1

Figure 3-51. MNVR display

3.3.4 Alert Tones

The TIME SPEC also contains controls to set times at which alert tones are sounded (two for selected mission times and one for the CRT timer) and also to set the duration of the SM alert tone (used in class 3 alarms).

Item 23 is used to set the duration of the SM alert tone, using an ITEM 23 + XY EXEC type entry, where XY represents the tone duration in seconds. This value can be set in a range from zero (which would inhibit the tone) to 99 seconds. This tone duration control alters the tone duration for all applications of the SM alert tone, and not just those related to the TIME SPEC. The time tone duration is initialized at 1 second and remains at that value until the crew takes action to change it.

3.3.5 Alert Tone Initiation

There are three sets of item controls on the TIME SPEC (Figure 3-52), which allow the user to enter time values when the alert tone will be sounded. These are usually to alert the crew to take some action at a given time in the mission. Two of these sets (items 3 to 5 and 6 to 8) allow the user to enter mission times for sounding the alert tone. When the current mission time equals the time input to one of these data sets, an SM alert tone is activated for the time period specified by the duration item. At the same time, a fault message (TIME TONE) is generated on all active PASS CRTs, and the SM alert light is illuminated. The involved data field also blanks at this time.

The third data set (items 20 to 22) allows the user to activate the alert tone at a specified CRT timer value. A negative value results in a tone when the CRT timer counts down to that value, and a positive input event time results in a tone when the CRT timer counts up to that value. The same responses and actions that pertain to the mission-time event timers also pertain to the CRT-timer event timer, except that this timer is major function specific.

Notice that alert tone times are only specified in terms of hours, minutes, and seconds and, therefore, can be set only within 24 hours of the desired time.

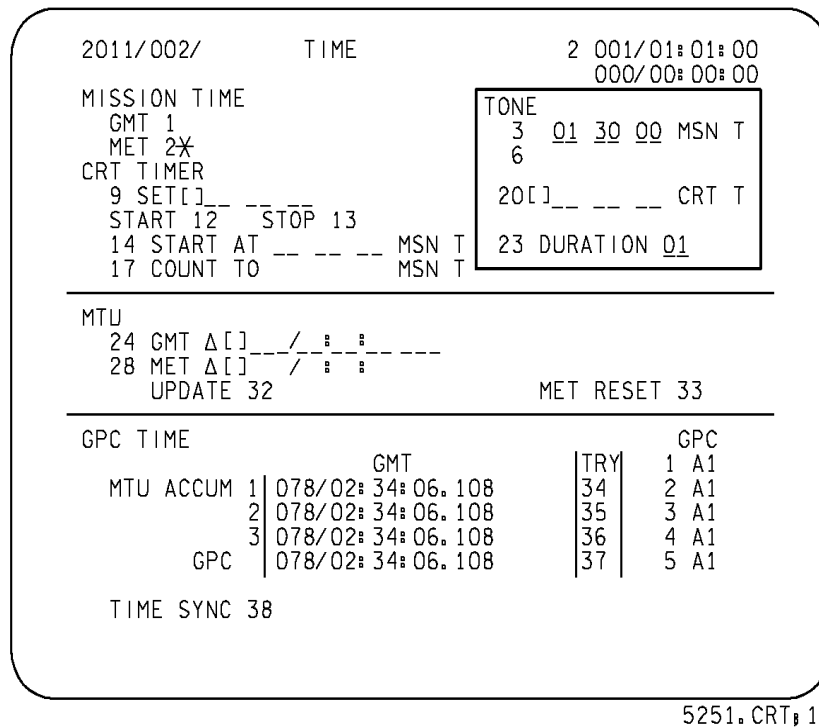

Figure 3-52. TIME display

3.4 GPC READ/WRITE

The contents of GPC main memory can be modified by the ground during prelaunch or in-flight via uplink. It can also be read or modified at any time by the crew via the GPC MEMORY display - SPEC 0.

The upper right portion of this display (Figure 3-53) contains the controls to perform a GPC Memory Read/Write (usually called a G-MEM). The current value of any GPC memory location can be observed by inputting its hexadecimal address. That value could then be changed, if necessary, by inputting a new halfword value or by setting or resetting individual bits.

It is important to note that this portion of SPEC 0 (which is also the OPS 0 display) is major function specific. Except in the case of RS GNC GPCs, only the GPC controlling the CRT are affected by READ/WRITE inputs. The major function resident in the GPC driving the display is displayed at the top next to READ/WRITE (GNC, SM, PL, or 000).

3.4.1 Memory Read Operations

There are many parameters that are not available on any hardware or other CRT displays in the crew station. However, the value of any parameter in GPC memory can be viewed by inputting its hexadecimal address on the GPC MEMORY SPEC (Figure 3-53).

This is done by using the DATA mode, item 20. The data can be observed in hexadecimal (HEX, item 27) or engineering units (ENG UNITS, item 26). If ENG UNITS is selected, the crew must also specify how it is to be displayed via a three-digit number. The first digit specifies 16 bit/fixed (1) or 32 bit/floating (2), depending on the type of data parameter to be viewed. The second and third digits specify the desired unit conversion, if any. For example, units can be converted from feet to nautical miles or degrees to radians. A list of the ten possible conversions is in the GPC MEMORY section of the DPS Dictionary. Inputting a value of 100 or 200 in item 26 displays the parameter in the units used in memory (without conversion).

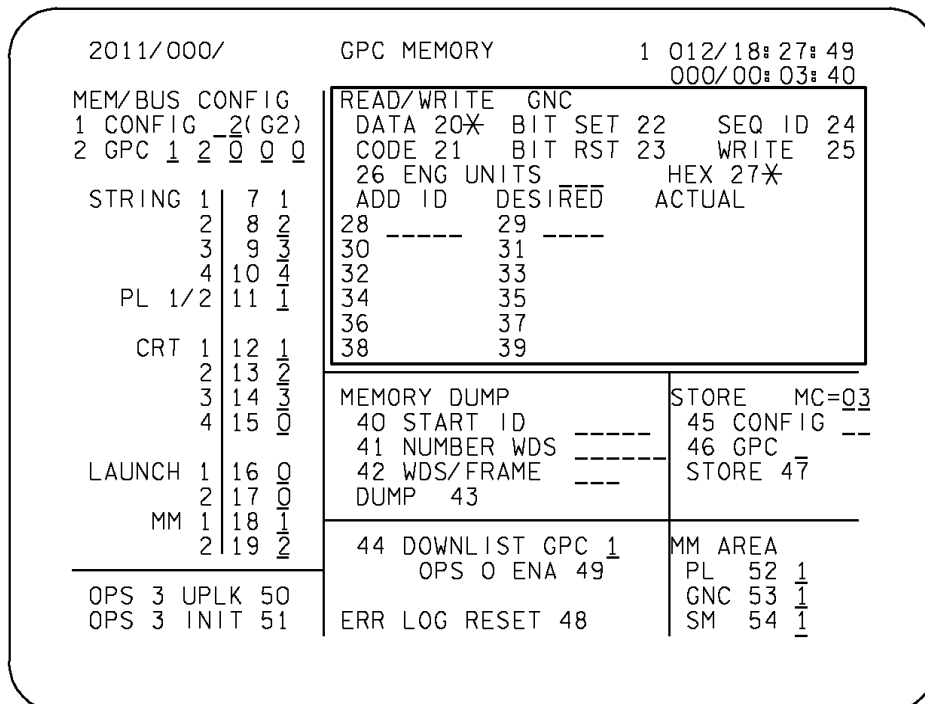

5252. CRT: 1

Figure 3-53. GPC MEMORY display

Once the above are selected, the five-digit hexadecimal address (ADD ID) of each data location to be viewed is input into items 28, 30, 32, etc. (leading zeroes need not be entered). The value of that address is then displayed in the ACTUAL column at right in the units selected (hexadecimal for item 27 or a 5-digit, decimal point, 5-digit field for item 26).

As an example, the crew might want to look at the values for the Reaction Control System (RCS) propellant quantities. SPEC 0 is always initialized with DATA and HEX selected when called; and ITEM 26 + 200 EXEC is entered to display the values in the units used in memory (percent) for these parameters. Once this is done, the address for the desired parameter is entered in item 28, and the value appears under ACTUAL. (Since these are dynamic parameters, the crew can hit the SPEC key to freeze the display at the current MET.)

The capability exists to display sequential memory locations by using ITEM 24 - SEQ ID. After entering a starting address under ADD ID, execution of item 24 fills out the rest of the table with consecutive addresses, and their values are displayed under ACTUAL as well. For the above example, item 24 can display all the quantities at once (the usual way it is done).

3.4.2 Memory Write Operations

Although the crew may read any GPC memory location, writing new GPC memory (G-MEMs) is only done for specific locations. All write procedures must be approved before being included in the FDF or called up from the ground. Untested WRITES are never done because of the possible impact of changing the flight software incorrectly.

3.4.2.1 Data

There are two basic ways to do a WRITE to main memory. One way is to input a whole new value (in hex) and the other is to set or reset individual bits in the hex word. Both of these employ an arm/fire method.

For the first way, the crew performs the same steps as for a READ operation, except that a WRITE cannot be done in ENG UNITS so HEX must be selected. Once the current values are displayed in the ACTUAL column, the crew inputs the DESIRED values in items 29, 31, 33, etc. It is very important that the crew check the ACTUAL column to ensure the current values are the ones expected. Otherwise, the addresses being used may be wrong. As with all items on this display, leading zeroes need not be entered.

Once the DESIRED values are keyed in and verified, a WRITE can be done by execution of item 25. The ACTUAL field then changes to reflect the new hex value, which can be verified by checking that DESIRED and ACTUAL are the same.

3.4.2.2 Code

Some locations in memory contain machine code instructions rather than data. In order to prevent inadvertent changing of such instructions, those locations are protected, which means a READ/WRITE cannot be performed on them unless the CODE mode (item 21) is selected. As further protection, the word code will flash if selected and the display automatically returns to DATA after a “write” to CODE.

Item 21 is described here for information only. It is rarely used in flight.

3.4.3 Bit Set/Reset Operations

The capability also exists to change individual bits of a memory location to a logical one (bit set) or to a logical zero (bit reset), as opposed to writing over the entire 16-bit location. Since it is done bit by bit, this function can only be done with HEX selected (Figure 3-54).

These two functions are especially useful when a specific data word is partially dynamic and the user wishes to alter only part of the data word while allowing the rest of the data word to update freely.

To perform a BIT SET, item 22 is selected. Then the appropriate ADD ID is entered as for any READ/WRITE. After the current value is verified in the ACTUAL column, a 16-bit mask word, represented by four hexadecimal characters, is input to the DESIRED column. The ones in this mask word identify the individual bits, which are to be set to a logical one in the target address. The others are unchanged. Item 25 then causes the bit set to take effect and the new value is displayed in the ACTUAL column. (Note that in this case, ACTUAL does not match DESIRED.)

The bit reset function works exactly the same way, except that after selection of item 23, the mask word specifies which bits are to be changed to zero. Wherever there is a “1” in the mask word, the corresponding bit in the word specified in item 28 is reset to “0.”

As an example, there is a procedure in the Malfunction Procedures book (Figure 3-55) for setting and resetting individual bits in the OMS tank valve command words. This is done if multiple failures make normal operations impossible. The details of such a failure scenario are beyond the scope of this book, but suffice it to say that the procedure has the crew reset certain bits to “0” in order to close some valves and to set certain bits to “1” in order to open others.

The BIT SET and BIT RST functions cannot be done to CODE locations. In fact, items 20, 21, 22, and 23 on SPEC 0 are mutually exclusive.

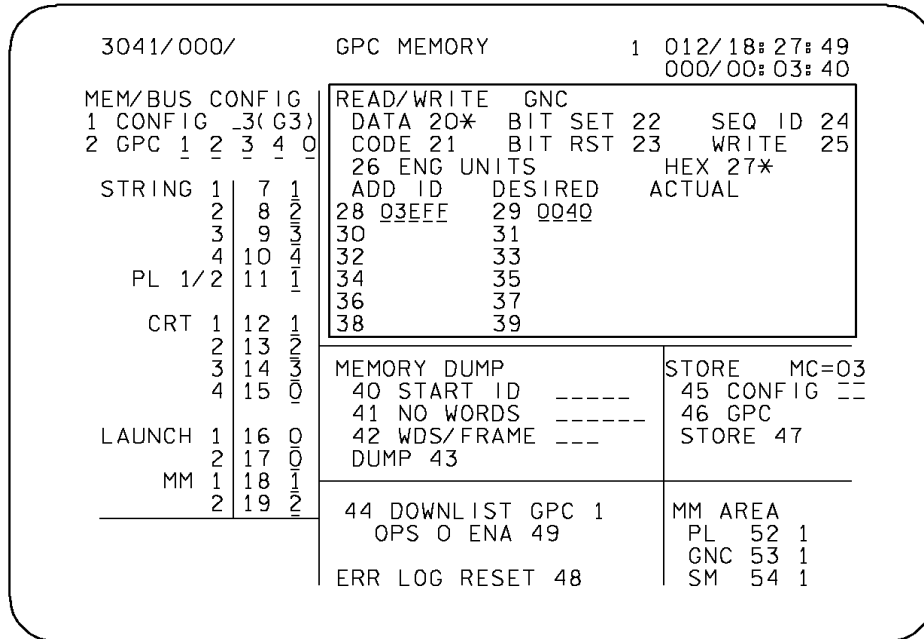

5057 CRT 7

Figure 3-54. GPC MEMORY display

OMS SSR-1
MIXED XFD: OMS PRPLT FAILURE

NOTE

Procedure uses MEMORY READ/WRITE to set appropriate OMS TK ISOL vlv and OMS XFEEED vlv commands in order to connect usable OMS tk to opposite side. For single tank or single inlet failures, select engine in good pod. Unstow ASC PKT and reference DEORBIT MIXED XFD BURN PREP procedure on 7-6 for reqd address IDs. Desired values are given in Tables 1 thru 8

- O8 1. L,R OMS TK ISOL (four) – CL (tb-CL)
XFEEED (four) – CL (tb-CL)
- O7 2. AFT L,R RCS XFEEED (four) – CL (tb-CL)
✓MSTR RCS XFEEED – OFF

WARNING
Do not use MSTR RCS XFEEED until post burn or loss of Deorbit capability may occur

3. Select failure case table

Single Failures	Use Table	Dual Failures	Use Table
L OMS OX TK	4	L OMS FU TK AND R OMS OX TK	1
L OMS OX INLET	4	L OMS OX TK AND R OMS FU TK	2
L OMS FU TK	6	L OMS FU TK AND R OMS OX INLET	3
L OMS FU INLET	6	L OMS OX INLET AND R OMS FU TK	4
R OMS OX TK	3	L OMS OX TK AND R OMS FU INLET	5
R OMS OX INLET	3	L OMS FU INLET AND R OMS OX TK	6
R OMS FU TK	5	L OMS OX INLET AND R OMS FU INLET	7
R OMS FU INLET	5	L OMS FU INLET AND R OMS OX INLET	8

- CRT 4. Set up GPC vlvs

GNC 0 GPC MEMORY

- ✓HEX 27*
BIT RST – ITEM 23 EXEC (*)
Obtain and enter ADD ID from ASC PKT, 7-6, DEORBIT MIXED XFD BURN PREP, step 3.
Obtain and enter DESIRED values from Tables 1 thru 8

ADD ID	DESIRED	Table A	Table B
28	29	----	----
30	31	----	----
32	33	----	----
34	35	----	----

} From Tables 1-8

- ✓Data values in ACTUAL column agree with Table A (MCC supplied)
WRITE – ITEM 25 EXEC
✓Data values in ACTUAL column agree with Table B (MCC supplied)

5. BIT SET – ITEM 22 EXEC (*)
Obtain and enter ADD ID from ASC PKT, 7-6, DEORBIT MIXED XFD BURN PREP, step 4.
Obtain and enter DESIRED values from Tables 1 thru 8

ADD ID	DESIRED	Table C
28	29	0 0 0 0
30	31	0 0 0 0
32	33	0 0 0 0
34	35	0 0 0 0

} From Tables 1-8

- ✓Data values in ACTUAL column agree with Table C
WRITE – ITEM 25 EXEC
✓Data values in ACTUAL column agree with DESIRED

- O8 6. During AOS, perform reconfig:
L,R OMS TK ISOL (four) – GPC
XFEEED (four) – GPC
✓Vlv config with MCC
7. Go to DEORBIT BURN (MIXED XFEEED) (Cue Card) to perform deorbit burn
(✓Burn engine in Tables 1 thru 8)

Figure 3-55. Malfunction procedures

OMS SSR-1 (Cont)

TABLE 1

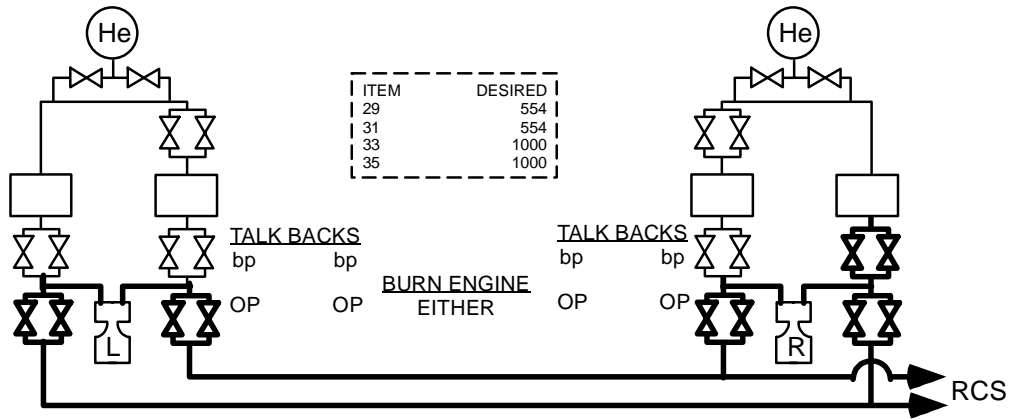
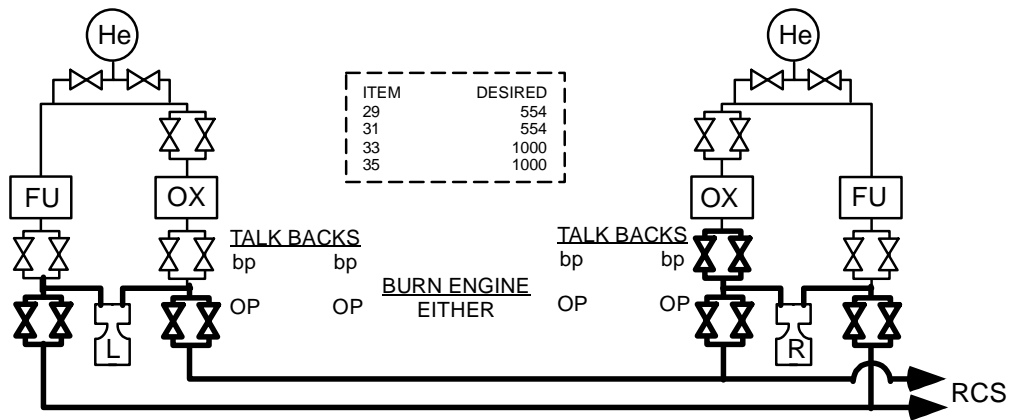

TABLE 2



usa005350_433

Figure 3-55. Malfunction procedures (concluded)

3.5 DOWNLIST

The flight controllers in the MCC maintain the status of onboard systems through data transmissions from the vehicle to the ground. These continuous transmissions are called the downlink and include GPC collected data, payload data, and instrumentation data as well as onboard voice. The GPC collected data is called the downlist and includes a set of parameters, which are chosen preflight for each mission phase.

Figure 3-56 illustrates the functional downlist/downlink data flow from the GPC to the ground. The system software in each GPC assimilates the specified GNC, SM, PL or DPS data according to the permission defined format for inclusion in the downlist. Each GPC is physically capable of transmitting its downlist to the current active PCMMU over its dedicated IP data bus although there are some software-imposed restrictions on this. (This point is discussed later in this section). The PCMMU interleaves the downlist data

from the different GPCs with the instrumentation and payload data (which is acquired directly by the PCMMU) according to the current TFL that is programmed in the PCMMU. The resulting composite data is called the operational downlink and is transmitted to the Network Signal Processor (NSP). In the NSP, the operational downlink is combined with onboard voice for downlink to the ground using the S-band system through the Spacecraft Tracking and Data Network (STDN) ground tracking stations, the Tracking Data Relay Satellite (TDRS), or the Ku-band system via TDRS and from there to the JSC MCC.

3.5.1 Composition of the Downlist

The composition of the downlist varies as a function of the memory configurations in the GPCs. The PASS downlist may include both GNC and SM GPC data. DPS hardware and system software data are always included.

The DPS hardware data downlisted include the BITE status of the IDPs, MMUs, and MTU. The ground can also see the major function, current display number, and scratch pad line for each of the four CRTs.

System software data sent to the ground include discrete inputs and outputs (such as GPC MODE and fail votes), RS and CS status, GMT and selected time source, latest GPC errors and I/O errors for each of the GPCs, last five fault messages, and the current bypasses and bus statuses.

Applications software data that is downlisted can include consumables quantities, power status for various units, BITE words, sensor data, switch positions, dedicated displays parameters, etc. Generally, the ground has more insight than the crew for most of the GNC, SM, and PL systems.

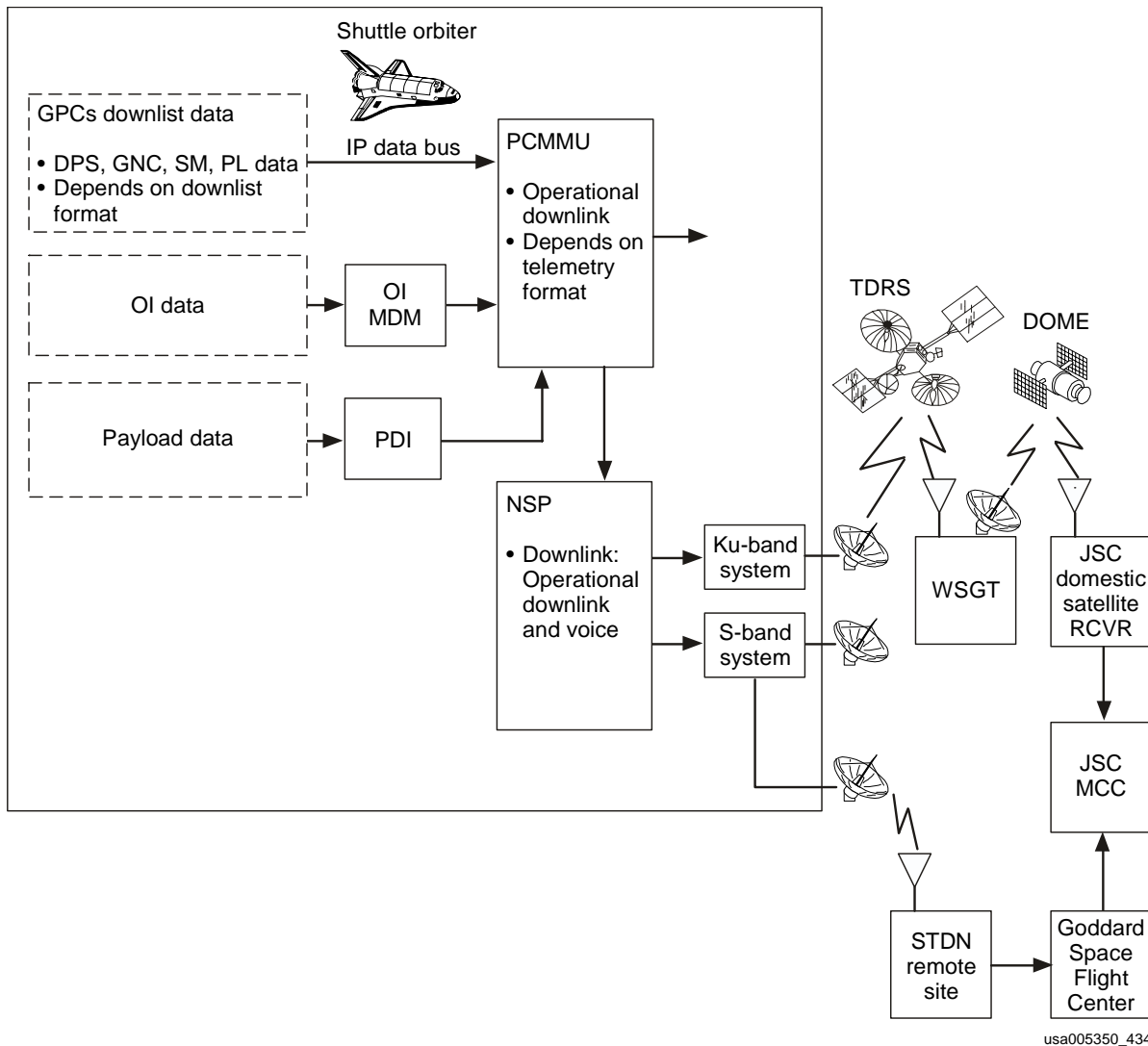

usa005350_434

Figure 3-56. Functional real-time downlink data flow

3.5.2 Variable Parameters

Most of the data to be included in the downlist is specified preflight. There is a capability, however, to include up to 10 extra parameters for each major function. These are called the variable parameters, and they can be controlled via items 25 to 34 on the DPS UTILITY (Figure 3-57) display, SPEC 1 (available any time). Each parameter is specified by its main memory address in hex and any memory locations up to FFFF can be input.

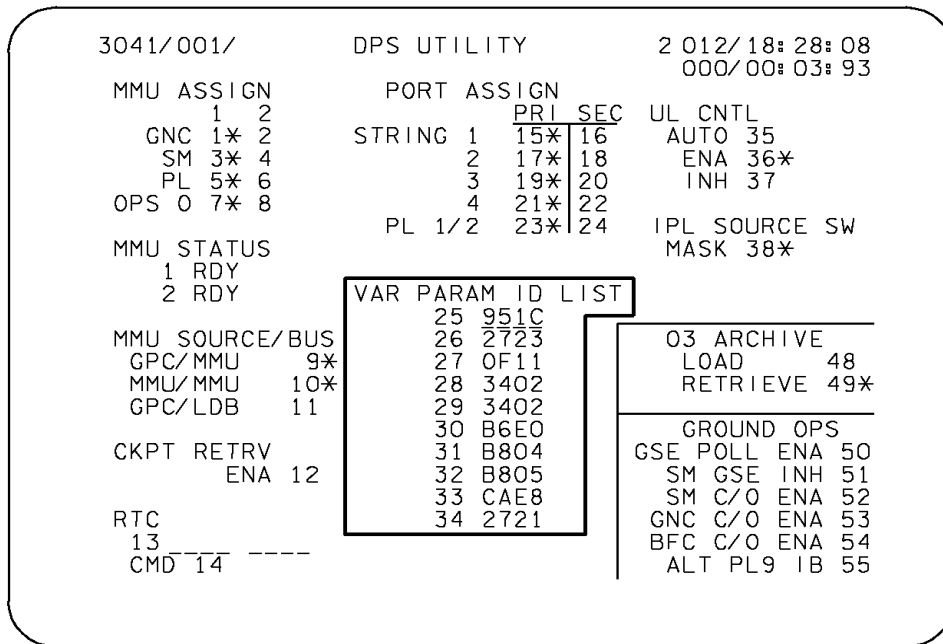

5254. CRT; 1

Figure 3-57. DPS UTILITY display

The set of variable parameters for each major function are initialized to some preloaded list, but that list can be changed at any time via SPEC 1. However, the crew does not normally change these parameters. They are usually controlled by the ground via uplink.

Any variable parameters input take effect immediately and remain until changed (even through OPS transitions). Variable parameters can include system software data such as string assignments and MMU selections, as well as applications software parameters. Note that there is a different set of variable parameters for each major function.

3.5.3 Downlist GPC

Since all GPCs operating in an RS are processing identical software, using identical inputs, and producing identical outputs, only the downlist from one member of the RS needs to be incorporated into the downlink and sent to the ground. The RS GPC whose downlist is incorporated into the downlink is called the downlist GPC.

Item 44 on the GPC MEMORY display gives the number of the GPC, which has been selected as the downlist GPC and can also be used to change the downlist GPC (Figure 3-58).

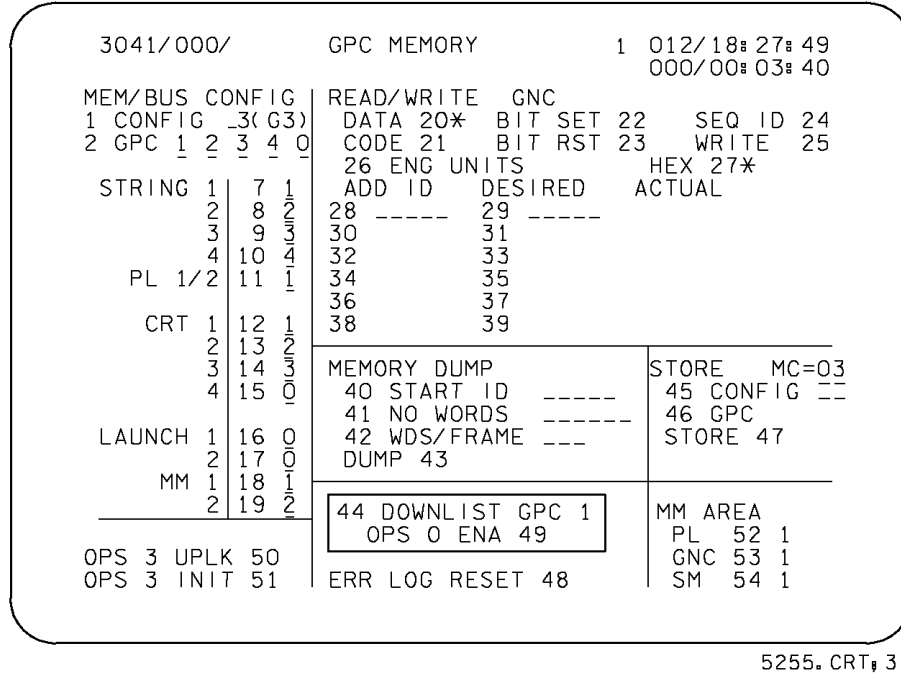

Figure 3-58. GPC MEMORY display

This item number is automatically selected to the lowest numbered GPC in the RS. This automatic selection occurs at RS formation (OPS transition or RS expansion/contraction with a change in RS membership) or when the current downlist GPC fails out of the RS (assuming that there remain at least two good RS GPCs).

The downlist GPC may also be manually changed by the crew, if the ground sees a problem with the GNC downlist or if the memory contents of a particular GPC need to be dumped. For a hardware dump of a failed GPC (since it uses the GNC downlist path) or a software dump of a good GNC GPC, the GPC to be dumped is selected as the downlist GPC. Since the SM GPC is already downlisting through a separate route, it need not be selected as the downlist GPC for a software dump.

The SM GPC could be selected as the downlist GPC if, for example, the current TFL did not support SM downlist (e.g., TFL 129, the "hard" format) and it was desired to look at SM data via the GNC downlist path for a time.

3.5.3.1 OPS 0 GPC

If it becomes necessary to receive downlist in MCC for an OPS 0 GPC, a new TFL (no. 163) is loaded into the active PCMMU. Then, item 49 is executed on the GPC MEMORY display (Figure 3-58) on a CRT commanded by that GPC. When this is no longer needed, item 49 is toggled back off, and the previous TFL is loaded back into the PCMMU. An OPS 0 GPC can also be dumped in this scenario (while the OPS 0 downlist is active), but that is not how it is typically accomplished. Since selecting any

good, active GPC (even an OPS 0 GPC) via item 44 substitutes that GPC's downlist for the nominal GNC downlister downlist, an OPS 0 GPC can be dumped in this way much more rapidly by sacrificing the GNC downlist until the dump is complete. Then, item 44 can be restored to its previous selection, restoring nominal GNC downlist.

3.5.4 GPC Downlist/PCMMU Interface

Every GPC that is actively downlisting sends its downlist to the active PCMMU over its own IP data bus, which is connected to one of five MIAs in each PCMMU. However, there is control logic in each PCMMU, which uses the TFL to determine how each downlist is forwarded. There are five memory areas, called toggle buffers (Figure 3-59), in the PCMMU where downlist data from the GPCs are stored. Each toggle buffer has two halves; one half is loaded with GPC data while the other is being read and the control logic automatically toggles from one half to the other. The number of a toggle buffer does not necessarily correspond to the GPC using it. For example, the SM GPC (nominally GPC4) data goes through toggle buffer 2, while the downlist GPC (GNC) uses toggle buffer 1 and BFS downlist is via toggle buffer 5. The GPCs encode a toggle buffer address in the downlist to determine which toggle buffer is to receive its downlist. As described in the previous section, the crew can also control which GPC downlists through the GNC downlist path. Usually only data from two or three toggle buffers is downlinked at once.

The control logic also determines which payload data from the PDI is stored in a RAM area as well as which instrumentation data from the OI MDMs are stored in its RAM in the PCMMU and then formatted into the downlink.

Each PCMMU has two telemetry formatters: one is high data rate (128 kilobit per second [kbs]) and the other is low data rate (64 kbs). The NSP data rate switch, on Panel A1, controls which rate is selected if either S-BAND PM CONTROL switch (Panels A1 and C3) is in PANEL while the ground controls the data rate if the S-BAND PM CONTROL switches are in CMD. The XMIT and RCV switches are normally in high, and low is only selected if a large amount of radio frequency interference is present, making low data rate necessary to obtain a good signal.

3.5.5 Telemetry Format Load

The TFL determines which set of data the telemetry formatter is to include in the downlink. There are two types of TFLs: hardware Fixed (FXD) TFL, which is programmed preflight, and two software Programmable (PGM) TFLs, which are changed as necessary during a mission. The FXD TFL is designed primarily for ascent but it also contains critical parameters necessary for ground support during any phase in case the PGM TFLs are lost. The PGM TFLs are in volatile memory in the PCMMU so they are lost whenever the current PCMMU loses power (e.g., when the crew switches PCMMUs since only one can be powered at a time).

There are two ways to select whether the fixed or programmable format is used. The format is selected via the OI PCMMU FORMAT switch on Panel C3 (Figure 3-60) when

the switch is in the FXD or PGM position. However, the switch is nominally left in the GPC position. After the PCMMU is loaded with the TFLs in GNC OPS 901 (prelaunch), the PCMMU is typically commanded to FXD for ascent. Neither PASS GNC OPS 1 nor the BFS have any software to command the PCMMU to a new format. Therefore, it stays in FXD until on-orbit operations start. On orbit, when SPEC 62 is available via SM OPS 2, the selection is done via items 1 and 2 on the PCMMU/PL COMM display (see Figure 3-61), and controlled by the SM GPC.

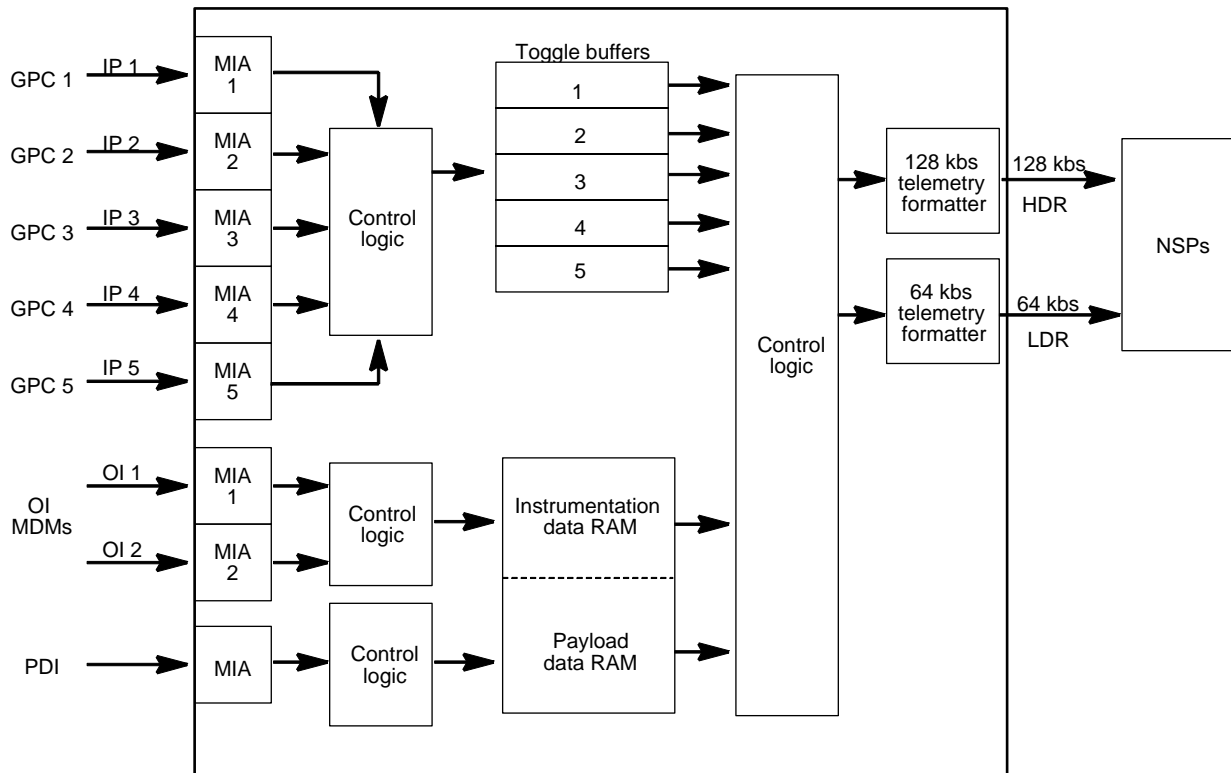

td292_363

Figure 3-59. Toggle buffers

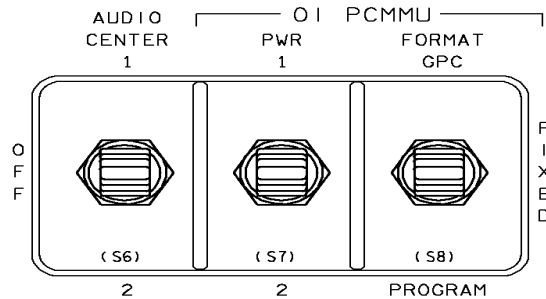

TD2920366. PNL# 1

Figure 3-60. Panel C3

These controls apply only to the high data rate formatter. The low data rate formatter uses only the PGM formats, so the OI PCMMU FORMAT switch and items 1 and 2 on SPEC 62 do not affect the low data rate formats.

3.5.5.1 Loading the TFL

The GPC downlist, payload, and instrumentation data that the ground needs to see depends on the current configuration and payload activity. Each particular phase has a specified set of data that is downlinked, and this set is defined and controlled by the 64 and 128 kbs TFLs (which can be changed by the crew anytime the SM GPC is available). The controls for loading the PROGRAM TFL are on SPEC 62 (Figure 3-61).

```

2011/062/          PCMMU/PL COMM          4 000/01:26:26
SM COM BUFF RDY          000/00:00:00
PCMMU
BITE WORD FFED          PDI
FMT                      I/O RESET 8X
SEL FXD      1          BITE WORD FFFF
      PGM      2X      9 SEL DECOM -
PGM ID 64 114          10 SEL FMT
      128 184          LOAD 11 CPT
3 SEL ID              12 SEL INPUT -
LOAD 4 CPT              LOAD 13
I/O RESET              DECOM INPUT FMT
PCM      5X              1      3      1
                          2      2      7
                          3      1      3
                          4      4      4
5-FPM
DECOM ENA
FDA 1 14
      2 15
      3 16
      4 17
PSP          PL INTRG
I/O RESET    1 CHANNEL
      PSP1    6
      PSP2    7 PHASE LOCK
SYNC BIT      ERR
FRAME        XMIT PWR
LOAD         PL SIG STR          18 TFL GPC SEL X
                                      (XX)

```

5256. CRT; 1

Figure 3-61. SPEC 62 - PCMMU/PL COMM display

The crew first selects the FORMAT IDs for the 64 and 128 kbs TFLs as desired from the table (an example is shown in Figure 3-62). First, the fixed format is selected (via the spec) while the programmable format is being changed. The crew then enters the desired IDs in item 3 and loads via item 4.

LOAD PCMMU FORMAT

- C3 1. \sqrt OI PCMMU FORMAT – GPC
SM 62 PCMMU/PL COMM
- CRT 2. FORMAT:
 FXD – ITEM 1 EXEC (*)
 SEL ID – ITEM 3 +X X X EXEC
3. \sqrt SM COMM BUF – RDY
 LOAD – ITEM 4 EXEC
 \sqrt LOAD, ITEM 4 – RUN,CPLT
- If LOAD – CPLT:
 Repeat steps 2 and 3 for second ID
- * If LOAD – FAIL and ERR MSG – 'I/O *
 * ERR MMU 1(2)': *
 * Go to 5.2a, 'I/O ERR MMU 1(2)' (MAL, *
 * DPS) >> *
 * *
 * If LOAD – FAIL and a first load attempt: *
 * Repeat steps 1 and 2 for failed ID *
 * *
 * If LOAD – FAIL and a subsequent load *
 * attempt: *
 * \sqrt MCC *
 C3 * OI PCMMU PWR – 2(1) *
 * \sqrt ERR MSG – 'I/O ERR PCM' *
 CRT * I/O RESET PCM – ITEM 5 EXEC (*) *
 * Repeat steps 2 and 3 *
4. When final LOAD – CPLT:
 PGM – ITEM 2 EXEC (*)

DNLIST COMPATIBILITY	PHASE	FORMAT ID 64/128	CONFIG NO.
G1,G3,BFS	(ASCENT)	102/FXD	–
G3,BFS	(ENTRY)	102/164	–
G2,G8,S2	ORBIT/ORBIT BURN/FCS C/O	103/161	–
G2,S2,OPS 0	OPS 0	–/163	–

Figure 3-62. Orbit OPS Checklist

This causes the SM GPC to request the indicated TFL from mass memory, which rolls into an area of memory in the SM GPC called the SM common buffer, and from there it is loaded into the PCMMU. During this time, the SM COMM BUFF indicates BSY. CPLT or FAIL is displayed next to item 4, depending on the success of the load.

The software automatically loads the TFL into the proper formatter. TFLs with Identification (ID) numbers less than 128 are for the low data rate formatter. When a load is successful, the new ID will be displayed next to 64 or 128 on SPEC 62. The crew may then load the second ID. When both TFLs are loaded, the crew then selects the programmable format again via item 2.

3.5.6 Loss of Downlist

Usually, problems affecting the GNC downlist are not annunciated to the crew. However, if the ground loses the GNC downlist, they will ask the crew to select another downlist GPC via SPEC 0 while the rest of the downlink continues. If changing downlisters does not restore data, then the problem is assumed to be at the PCMMU, and the crew would be asked to select the other PCMMU via the OI PCMMU POWER switch on Panel C3. This switchover can be done at any time, but it causes the fixed format to be used until the programmable format can be reloaded via SPEC 62 (on orbit).

Since the SM GPC inputs OI data from the PCMMU, it can detect an interface problem and annunciate an I/O ERROR PCM fault message. In this case, the procedures instruct the crew to bring up the BFS GPC to see if it can talk to the PCMMU. This determines whether the problem is at the SM GPC or the PCMMU.

Certain failures of a GPC's transmitter on its IP data bus can be detected by any PASS GPC and are annunciated by an I/O ERROR D/L fault message. Procedures are similar to the cases above.

3.5.7 Memory Dumps

The capability exists to dump selected portions or all of GPC main memory to the ground in place of the usual downlist. The contents of main memory are dumped to the ground for failure analysis in case of a GPC failure or for verification if a G-MEM is entered to correct a problem found in flight software during flight.

There are two ways to dump GPC main memory. A hardware initiated dump is used for failed GPCs, and a software controlled dump is used for GPCs that are running. In either case, the dump takes the place of the data in an entire downlist path until the dump is completed, at which time the nominal downlist is restored.

3.5.7.1 Software Memory Dump

Whenever a GPC fails, besides dumping the contents of that GPC to the ground, the crew dumps the contents of a good GPC that was running in the same RS or CS at the time. This aids the ground in failure analysis since there are error logs in the good GPC

that can yield information about the type of failure (based on what type of communication the good GPC did or did not receive from the failed one). The software controlled memory dump is used for the good GPC.

The controls for a software dump are on the GPC MEMORY display - SPEC 0 (see Figure 3-63). Any section of main memory may be dumped, by specifying the starting address, by entering its hex ID in item 40 and then entering the number of consecutive halfwords to be dumped in item 41 (in decimal). In nearly all cases, however, the entire contents of the GPC are dumped by simply executing item 43 while leaving the other items blank.

MEM/BUS CONFIG		READ/WRITE GNC																					
1	CONFIG 2(G2)	DATA 20*	BIT SET 22																				
2	GPC 1 2 0 0 0	CODE 21	BIT RST 23																				
		26 ENG UNITS	HEX 27*																				
		ADD ID	DESIRED ACTUAL																				
STRING 1	7 1	28	29																				
2	8 2	30	31																				
3	9 3	32	33																				
4	10 4	34	35																				
PL 1/2	11 1	36	37																				
		38	39																				
CRT 1	12 1	<table border="1"> <thead> <tr> <th colspan="2">MEMORY DUMP</th> <th>STORE</th> <th>MC=03</th> </tr> </thead> <tbody> <tr> <td>40</td> <td>START ID</td> <td>----</td> <td>45 CONFIG</td> </tr> <tr> <td>41</td> <td>NUMBER WDS</td> <td>----</td> <td>46 GPC</td> </tr> <tr> <td>42</td> <td>WDS/FRAME</td> <td>----</td> <td>STORE 47</td> </tr> <tr> <td>DUMP</td> <td>43</td> <td>----</td> <td></td> </tr> </tbody> </table>		MEMORY DUMP		STORE	MC=03	40	START ID	----	45 CONFIG	41	NUMBER WDS	----	46 GPC	42	WDS/FRAME	----	STORE 47	DUMP	43	----	
MEMORY DUMP				STORE	MC=03																		
40	START ID			----	45 CONFIG																		
41	NUMBER WDS			----	46 GPC																		
42	WDS/FRAME	----	STORE 47																				
DUMP	43	----																					
2	13 2																						
3	14 3																						
4	15 0																						
LAUNCH 1	16 0	44 DOWNLIST GPC 1	MM AREA																				
2	17 0	OPS 0 ENA 49	PL 52 1																				
MM 1	18 1		GNC 53 1																				
2	19 2		SM 54 1																				
OPS 3	UPLK 50	ERR LOG RESET 48																					
OPS 3	INIT 51																						

5252. CRT# 1

Figure 3-63. GPC MEMORY display

The procedure is shown in Figure 3-64. First, the crew checks that the OPS recorders are in the right configuration to record the entire dump (if this vehicle has tape-type MMUs) and recorders, just in case MCC does not receive it live.

Since the dump takes the place of the downlist through one of the toggle buffers, a compatible TFL may need to be loaded to accommodate the change in downlist. The SM GPC dump goes through its own toggle buffer, but a GNC GPC must be specified as the downlist GPC if it is not already since only one GNC GPC is allowed to transmit to the PCMMU at one time.

The dump is then started by executing item 43. At this point, the START ID begins incrementing and the NO WDS counts down. Both values go blank when the dump is complete. A software dump can take from 2 to 10 minutes. The crew can then reselect the desired TFL for that phase.

DPS SSR-2 GPC S/W INITIATED MEM DUMP

NOTE

Perform AOS. This procedure will generate a complete GPC Software Memory Dump in all in-flight OPS. Single item entry dumps must be performed in a HDR TFL

1. If vehicle configured with tape-driven MMU: ✓MCC to ensure OPS RCDR 1(2) configured for dump
2. **SM 62 PCMMU/PL COMM**
If reqd, load dump TFL: LOAD PCMMU FORMAT (ORB OPS FS, COMM/INST)
3. If PASS:
 - a. If GNC, SM, or PL9 Memory Dump:
On display assigned to GPC to be dumped,
GNC(SM,PL) 0 GPC MEMORY
If a specific GNC GPC to be dumped,
✓DOWNLIST GPC – ITEM 44 +X EXEC
DUMP START/STOP – ITEM 43 EXEC
Item 40 (up), 41 (down) entries begin counting
Dump complete when ITEMS 40,41 blank
 - b. If an OPS 0 GPC Memory Dump:
If target OPS 0 GPC MODE – HALT:
✓Appropriate AV Bay Fan – ON
✓Target GPC PWR – ON
Target GPC MODE – STBY (tb–RUN)
– RUN (OUTPUT tb–gray)
Assign desired IDP/CRT to OPS 0 GPC: GPC/CRT XX EXEC
PL 0 GPC MEMORY
DOWNLIST GPC – ITEM 44 +X EXEC
DUMP START/STOP – ITEM 43 EXEC
Item 40 (up), 41 (down) entries begin counting
Dump complete when ITEMS 40,41 blank
DOWNLIST GPC – ITEM 44 +X EXEC (lowest ID GNC GPC)

MF/OPS	GNC(OPS 0)	SM	PL9
DUMP TIME	2.2	5.7	MAX = 9.7
4. If BFS:
GNC 0 BFS MEMORY
DUMP START/STOP – ITEM 24 EXEC
Item 21 (up), 22 (down) entries begin counting
Dump complete when ITEMS 21,22 blank (after 8 min)
5. **SM 62 PCMMU/PL COMM**
If reqd, load post-dump TFL:
LOAD PCMMU FORMAT (ORB OPS FS, COMM/INST)

Figure 3-64. Malfunction procedures for software dump

3.5.7.2 Hardware Memory Dump

Hardware controls are used to dump a failed GPC since it is always moded to HALT and, therefore, no software is being processed. A hardware GPC memory dump is correctly called a Hardware Initiated Stand-Alone Memory (HISAM) dump.

The dump is set up by putting the failed GPC's power in ON, its OUTPUT switch in TERMINATE, its MODE switch in HALT, and then selecting the number of the failed GPC on the GPC MEMORY DUMP rotary switch on middeck Panel MO42F (Figure 3-65). The OPS recorder is then checked as for a software dump (if this vehicle has tape-type MMUs and recorders), and a compatible TFL is loaded if the current one or the FXD TFL does not suffice. In order to avoid downlist conflict, the failed GPC is selected as the downlist GPC and the dump data replaces the GNC downlist in the downlink. Moding the GPC to STBY starts the dump, which takes 4 minutes for a failed PASS GPC and 6.5 minutes for a failed BFS GPC. Since there is no indication of dump completion, the crew just waits that long before reconfiguring by moding the failed GPC back to HALT, reselecting the downlist GPC, turning off the GPC MEMORY DUMP switch, and either reloading or reselecting the previous TFL.

The hardware dump procedure is shown in Figure 3-66.

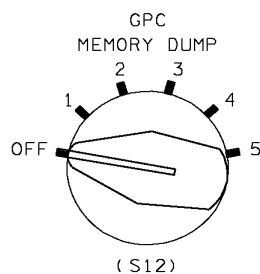

TD2920369. PNL 1

Figure 3-65. Panel MO42F

**DPS SSR-1
GPC HDW INITIATED MEM DUMP**

- NOTE
Perform during AOS
- O6 1. ✓ GPC MODE 1(2,3,4,5) - HALT
PWR 1(2,3,4,5) - ON
OUTPUT 1(2,3,4,5) - TERM
- MO42F GPC MEM DUMP - 1(2,3,4,5)
Perform next step at noted dump time
2. SM 62 PCMMU/PL COMM
If reqd, load dump TFL: LOAD PCMMU FORMAT (ORB OPS FS, COMM/INST)
3. If PASS:
Select failed GPC X as downlist (avoids downlist contention)
SM(GNC) 0 GPC MEMORY
DOWNLIST GPC - ITEM 44 +X EXEC
- O6 4. GPC MODE 1(2,3,4,5) - STBY (starts dump)
Wait: Double dump of PASS GPC complete after 4 min; single dump of BFS complete after 8 min
- O6 GPC MODE 1(2,3,4,5) - HALT (stops dump)
OUTPUT 1(2,3,4,5) - NORM
5. If PASS:
Select lowest ID GNC GPC X as downlist
SM(GNC) 0 GPC MEMORY
DOWNLIST GPC - ITEM 44 +X EXEC
- MO42F 6. GPC MEM DUMP - OFF
7. SM 62 PCMMU/PL COMM
If reqd, load post dump TFL:
LOAD PCMMU FORMAT (ORB OPS FS, COMM/INST)

Figure 3-66. Malfunction procedures for hardware dump

3.5.7.3 Mass Memory Dump and R/W

The capability also exists in SM OPS 2 or 4 and PL OPS 9 to dump selected portions of either MMU. This capability is normally not used in flight and there is no procedure for it in the FDF. It is mentioned here for information only.

The MASS MEMORY R/W SPEC, illustrated in Figure 3-67, is available as SPEC 85 in SM OPS 2 and 4 and as the PL OPS 901 OPS display. It can allow the crew or ground (via uplink) to control the capability to observe selected mass memory data on the CRT, modify this data, dump selected mass memory data to the ground via the downlist, or compare one MMU to the other.

```

2011/085          MASS MEMORY R/W          4 000/10: 10: 02
SM COM BUFF RDY                                     000/00: 00: 00
DESIRED ACTUAL   DESIRED ACTUAL
 1  ----          21  ----          SELECT
 2  ----          22  ----          MMU 1          40
 3  ----          23  ----          MMU 2          41
 4  ----          24  ----          42 S/W SYSTEM   -
 5  ----          25  ----          43 PHASE        ---
 6  ----          26  ----          44 LOAD BLK     ---
 7  ----          27  ----          45 OFFSET      -----
 8  ----          28  ----          46 NUMBER       ---
 9  ----          29  ----          47 PATCH ID     ---
10  ----          30  ----          VIOLATE        -----
11  ----          31  ----          READ LOAD BLK  48
12  ----          32  ----          MERGE          49
13  ----          33  ----          WRITE LOAD BLK 50
14  ----          34  ----          COMPARE        51
15  ----          35  ----          STATUS
16  ----          36  ----          ERROR CODE
17  ----          37  ----          REGISTER A    0000
18  ----          38  ----          REGISTER B    0000
19  ----          39  ----          MM VERSION    .
20  ----          CHECKSUM          DUMP VIA DL    52

```

5258. CRT; 1

Figure 3-67. SPEC 85 - MASS MEMORY R/W display

3.6 UPLINK

Uplink is the method by which ground commands, originating in the MCC, are generated, formatted, and transmitted to the orbiter for validation, processing, and eventual execution by onboard software. This capability allows the ground to control software processing, effect mode changes in orbiter hardware, and to store or change software in GPC main memory and mass memory.

3.6.1 Uplink Command Flow

Commands are issued from MCC workstations, which request uplink communications. The command requests are then formatted into a command load for transmission to the orbiter. There are two methods of transmitting the operational uplink (commands plus voice). See Figure 3-68.

The primary method involves the TDRS system, which can transmit the uplink to the orbiter via either Ku-band or S-band. The other method uses the STDN sites and the S-band only. The transponder receivers onboard the orbiter demodulate the uplink and send the commands to the active NSP. The NSP validates and buffers the commands until requested by the GPCs via an FF MDM. The GPCs also validate the commands before executing them. Those GPCs not listening directly to the FC data buses receive uplink commands over the ICC data buses from the GNC GPCs.

NSP 1 is connected to FF1 and NSP 2 is connected to FF3. Only one NSP is powered/used at a time, and the NSP selection can be controlled by the crew via the NSP POWER switch on Panel A1 if the S-BAND PM CONTROL switch (Panels A1 and C3) is in PANEL. NSP selection is controlled by the ground if the CONTROL switch is in command (CMD) (usual position). However, since ground commands must go through the NSP, the ground cannot switch over to the other NSP if the current one fails. Therefore, in this case, the ground tells the crew to do a “PANEL/CMD” since the NSP POWER switch is preset to the other NSP. Going to PANEL causes the switch to be read, and the other NSP is selected. Going back to CMD restores ground control via the new NSP.

The crew does a PANEL/CMD on their own if a BCE STRGX NSP fault message is annunciated and they are not in contact with the ground.

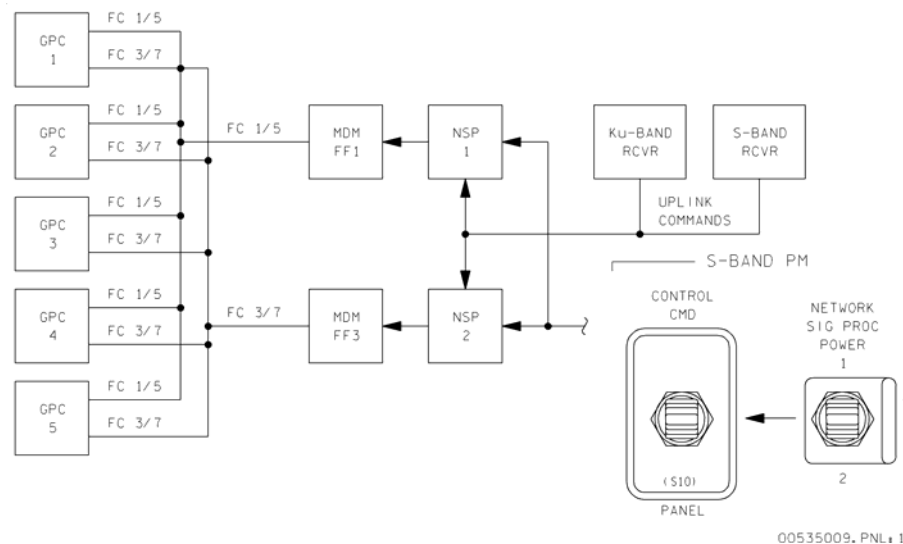

Figure 3-68. Uplink command flow

3.6.2 Types of Uplink Commands

Uplink commands can be issued to any of the GPCs by specifying a GPC by number, selecting all GPCs in a given major function, or selecting all GPCs in the CS. A code in the command load built by the MCC identifies the GPC to receive the commands.

There are three types of command loads: single-stage commands, two-stage (or critical) commands, and Stored Program Commands (SPC).

Single-stage commands are executed by the GPC software as soon as they are received. They are used principally to control the other two types of commands and for certain payloads.

Most commands uplinked to the GPCs are two-stage commands. In the first stage, the command is just stored in the two-stage buffer. While being stored, “UL” flashes at the

top of all CRTs associated with the GPCs being commanded (see Figure 3-69), and the buffer contents are then downlisted to the ground for verification of reception of the correct load. The second stage is when the ground sends a single-stage BUFFER EXECUTE command to tell the GPC to execute the command in the buffer and the UL indicator is then blanked.

```

3041/001/      DPS UTILITY      UL 1  012/18: 28: 08
                000/00: 03: 23

MMU ASSIGN      PORT ASSIGN
  1  2          STRING 1 15X 16
GNC 1X 2      2  17X 18
SM 3X 4      3  19X 20
PL 5X 6      4  21X 22
OPS 0 7X 8   PL 1/2 23X 24

MMU STATUS      UL CNTL
  1 RDY          AUTO 35
  2 RDY          ENA 36X
                INH 37

MMU SOURCE/BUS  VAR PARAM ID LIST
GPC/MMU 9X      25 9510
MMU/MMU 10     26 2723
GPC/LDB 11     27 0F11
                28 3402
                29 3402
                30 86E0
CKPT RETRV     31 8804
  ENA 12       32 8805
                33 CAE8
                34 2721

RTC            GB ARCHIVE
13-----
CMO 14        LOAD 48
                RETRIEVE 49X

GROUND OPS
GSE POLL ENA 50
SM GSE INH 51
SM C/O ENA 52
GNC C/O ENA 53
BFC C/O ENA 54
ALT PL9 TB 55

```

00535003. CRT: 1

Figure 3-69. DPS UTILITY display

SPCs are buffered and verified in the same fashion as two-stage commands. The difference is that they are timetagged and are automatically executed by the GPC at the specific GMT. Single-stage commands can be used to clear or correct the two-stage buffer or SPC buffers, if necessary.

The ground can uplink almost any set of data via these commands. The usual kinds of uplinks include IMU compensations, state vectors, TMBUs (fault detection limit changes), and G-MEM writes.

3.6.2.1 IDP Equivalent

One kind of two-stage command called an IDP equivalent allows the ground to perform any CRT function as the crew, just as if the ground had its own keyboard. In other words, via uplink, the ground can do OPS transitions, select CRT displays, and execute item entries on any CRT, even one that is powered off. Display Electronic Unit (DEU) equivalents are done for such things as commanding an attitude change while the crew is asleep. If powered, the CRT will display the results of any entries made by the ground (but not the scratch pad line entry, since that is only an echo [by the IDP, not the GPC] of real keyboard entries by the crew). This type of uplink is typically coordinated with the crew (if awake), in order to avoid surprises.

3.6.2.2 Real-Time Commands

A Real-Time Command (RTC) is the capability to set or reset discrete outputs in the MDMs. Normally, RTCs are uplinked by the ground. They are used by the ground to reconfigure the uplink/downlink system (for example, switching NSPs), when in CMD mode, since that control is via the PL MDMs. RTCs can also be sent to the FC and launch MDMs in case of switch or data path failures.

Although it is rarely used, the crew also has the capability to send RTCs. This is done via items 13 and 14 on the DPS UTILITY display - SPEC 1. In order to send an RTC, the crew would have to obtain the eight-digit command word from the MCC. This word, which specifies the MDM and the outputs to be set or reset, is entered in item 13. Execution of item 14 sends the command. See Figure 3-69.

3.6.3 Uplink Control

In order to prevent the uplink of spurious commands from somewhere other than the MCC, there is a capability for the crew to control when the GPCs will accept uplink commands and when uplink will be blocked. This capability includes both hardware and software controls

3.6.3.1 Uplink Switch

Hardware control of the uplink block function is via the UPLINK switch on Panel C3 (Figure 3-70). It is a three-position toggle switch that can be set to NSP BLOCK, GPC BLOCK, or ENABLE, as shown below.

- a. In the NSP BLOCK position, a signal is sent to each NSP that causes the NSP to respond to GPC polling incorrectly and that response, in turn, causes the GPC to declare an I/O ERROR against that NSP. The fault message issued is BCE STRG X NSP where X is the string with the currently active NSP.

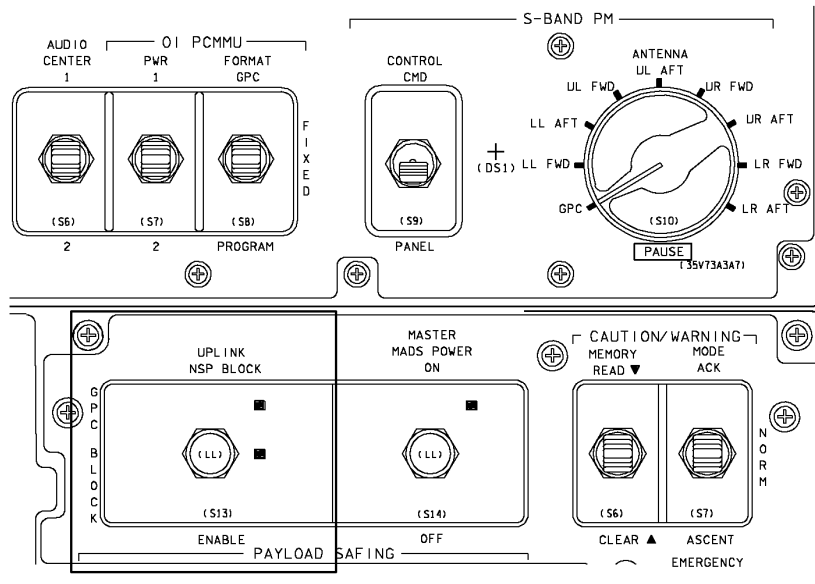

Figure 3-70. Panel C3

In this position, the GPC does not request any uplink data from the NSPs and thus is blocked from UPLINK command. If the switch is moved to this position, the GPC must receive an I/O RESET EXEC input in order to resume contact with the NSP once the switch is returned to one of the other positions. This switch position is not normally used.

- a. The GPC BLOCK position is the way the crew normally inhibits uplink during ascent. The signal from this switch position goes to the GNC GPC(s) (via FF1 and FF3), which then inhibit uplink processing. This position of the switch is selected prelaunch. Since the NSP is not bypassed, no I/O RESET EXEC is necessary when moding out of GPC BLOCK.
- b. The ENABLE position allows the GPCs to process all uplinks, depending on the type of uplink control selected on the DPS UTILITY display (described next). This position of the switch is selected once orbit is reached and remains selected the rest of the flight, unless long periods of Loss of Signal (LOS) are anticipated.

During ascent and entry, the software control is set to enable all uplink.

3.6.3.2 Software Uplink Control

Whenever the UPLINK BLOCK switch is in Enable (ENA) the crew controls uplink via items 35 - 37 on DPS UTILITY, SPEC 1 (Figure 3-71). (Otherwise these items have no effect.)

- a. Item 35 - AUTO is selected whenever there is an SM GPC operating. The SM GPC automatically enables or inhibits uplink depending upon whether the vehicle is currently over a ground site or in TDRS coverage (that is, Acquisition of Signal (AOS)). To determine this, the SM GPC uses the vehicle state vector from GNC (via ICC).

- b. Item 36 - ENA is executed whenever there is no SM GPC to control uplink. Item 36 enables all uplink regardless of vehicle location. It is selected before the SM GPC is brought down during the procedures to prepare for deorbit.
- c. Item 37 - INH inhibits any uplink from being processed. This item is normally not used.

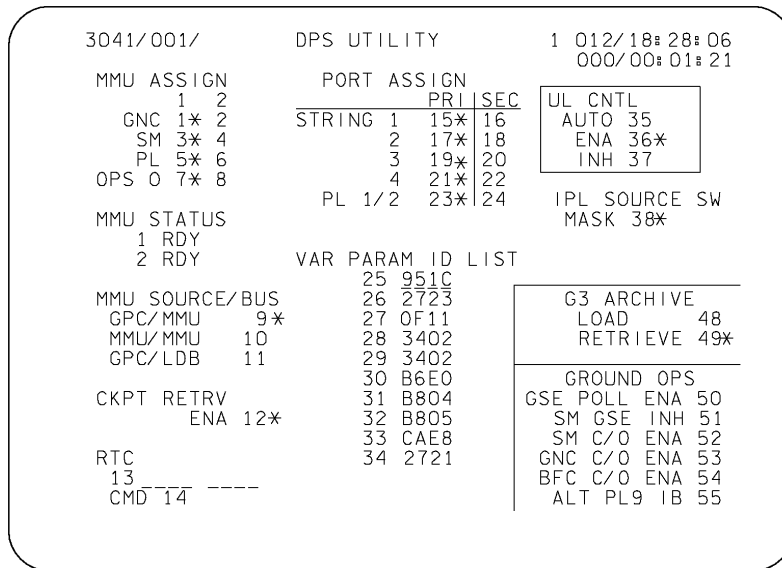

5260. CRT# 2

Figure 3-71. DPS UTILITY display

3.7 INITIALIZATION AND RECOVERY

3.7.1 IDP Initialization and Recovery

The IDPs also contain software that can be reloaded in flight in the highly unlikely case that it becomes necessary, just as they were preflight. An IDP LOAD is usually performed only after other troubleshooting and MCC concurrence. A PASS GPC has the software to support an IDP LOAD in SM OPS 2, PL OPS 9, or right after being IPL'd. Therefore, the easiest approach is to use the SM GPC to LOAD an IDP. During entry, it is not possible to do a PASS IDP LOAD; so a BFS IDP LOAD is done, which does not include the PASS critical display formats. However, these should be preserved in EEPROM in the IDP.

To perform an IDP LOAD, the IDP is powered ON and the PL major function is selected (to avoid any conflict in CRT commanders). The IDP is deassigned from PASS and BFS and the IDP LOAD momentary switch on Panel O6 (Figure 3-72) is taken to LOAD. At this point, a VM LOAD IN PROGRESS message should appear on the CRT and the IDP is ready to be loaded. When the GPC to perform the LOAD is assigned to the IDP, it sees the LOAD discrete and performs the LOAD. As soon as it is complete, a normal, active CRT display appears. The IDP can then be assigned to any GPC for normal operation.

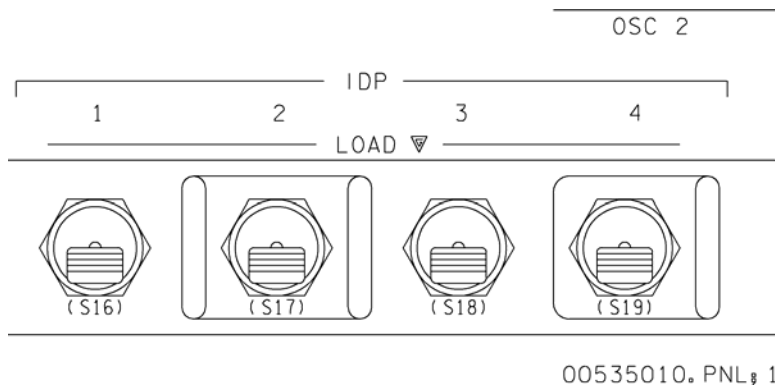

Figure 3-72. Panel O6 - IDP load switches

3.7.2 GPC Initialization and Recovery

The procedures for recovering a GPC that has had a failure are the same as the procedures used to initialize and activate the GPCs preflight. In either case, an IPL is performed, which loads (or reloads) the basic system software (OPS 0 in PASS) into the GPC from mass memory. (This is done only after a hardware dump in the case of a failed GPC). Since some hardware discrettes are reset, it is possible for an IPL to clear a problem as well as recover from a transient failure.

There are two methods of IPL'ing a GPC. The first is called the default option and can only be used to IPL a PASS GPC. The second is called the menu option and can be used for PASS or BFS. The default option is the usual method used for PASS GPC IPL, since it is simpler. The menu option is explained in the BFS section.

The default option for PASS GPC IPL is shown (Figure 3-73). It differs from the menu option in that the CRT display (GPC IPL MENU) is not used. When an initialized GPC is taken to STBY and sees that no CRT is selected via the BFC CRT switch on Panel C3 (next page), it defaults to a load of PASS software.

**DPS SSR-8
GPC IPL-PASS**

NOTE

==MCC for reapplication of GMEMs as reqd

1. **SM 1 DPS UTILITY**
IPL SOURCE SW MASK – ITEM 38 EXEC (no *)
- C3 2. BFC CRT DISP – OFF (BFS will default to IDPs 1,2 if engaged)
- O6 3. IPL SOURCE – MMU 1(2)
GPC OUTPUT 1(2,3,4,5) – NORM (tb-bp)
MODE 1(2,3,4,5) – HALT (tb-bp)
- F7 4. GPC PWR 1(2,3,4,5) – OFF,ON
If BFS engaged:
FLT CNTLR PWR – ON
BFS ENGAGE pb – push
- If off-diagonal CAM lts on, execute error log reset:
GNC 0 GPC MEMORY
ERR LOG RESET – ITEM 48 EXEC
Repeat for SM, PL, OPS 0 as applicable
5. IPL 1(2,3,4,5) pb – push (tb-IPL, then bp within 2 min)
6. When tb – bp or 2 min:
GPC MODE 1(2,3,4,5) – STBY (Tape-driven MMU: tb-RUN within 2 min, expect CAM diagonal for 1 sec and Master Alarm) (Solid State MMU: tb RUN within 2 min, no CAM or Master Alarm expected)
7. When tb – RUN or 2 min, determine if IPL'd GPC can command IDP:
If BFS not engaged:
 - O6 a. GPC MODE1(2,3,4,5) – RUN (tb remains RUN)
==OUTPUT 1(2,3,4,5) – NORM (tb-gray)
 - C2, R11 b. Desired IDP/CRT MAJ FUNC – PL
 - c. GPC/CRT IPL'd GPC/desired IDP EXEC
 - d. ==**PL 0 GPC MEMORY** driven by IPL'd GPC
 If BFS engaged:
 - C3 a. BFC CRT DISP – ON
SEL – 3+1
 - b. If BFS commanding IDP2,
BFS – GPC/CRT 02 EXEC
 - C2 c. IDP/CRT2 MAJ FUNC – PL
 - O6 d. GPC MODE 1(2,3,4,5) – RUN (tb remains RUN)
OUTPUT 1(2,3,4,5) – NORM (tb-bp)
 - e. If another PASS GPC active, using IDP2
GPC/CRT IPL'd GPC/2 EXEC
==**2: PL 0 GPC MEMORY** driven by IPL'd GPC
8. If GPC CANNOT command IDP:
GPC MODE 1(2,3,4,5) – HALT
If first IPL attempt:
IPL SOURCE – MMU 2(1)
BFS CRT DISP – OFF
Go to step 4 and proceed (one time only)
If second IPL attempt:
GPC PWR 1(2,3,4,5) – OFF
- O6 9. IPL SOURCE – OFF
10. **SM 1 DPS UTILITY**
IPL SOURCE SW MASK – ITEM 38 EXEC (*)

Figure 3-73. Malfunction procedures

The first step in the procedure is to inhibit the IPL SOURCE switch mask via item 38 on SPEC 1. This item normally masks, or prevents, PASS GPCs from using the discrettes from the IPL SOURCE switch. The purpose of these discrettes is to prevent an active PASS GPC from trying to access the MMU selected by the switch while another GPC is being IPL'd. However, a failure mode exists for this switch that can set all the discrettes at once. This can prevent an active PASS GPC from accessing either MMU at all. This was more of a concern for TALs prior to the advent of the G3 archive in the upper memory of the AP-101S GPCs. Thus, the software was developed to close the window of vulnerability to the switch failure mode. For an IPL, however, it is desirable to have the GPCs avoid the MMU that the IPL'ing GPC is using.

As was mentioned before, the second step is to turn off the BFC CRT DISP switch so that the IPL'ing GPC knows to do a default IPL. Once the GPC switches are configured, the crew enters ITEM 48 EXEC to SPEC 0 in both GNC and SM, as needed, to turn off any fail votes (CAM lights) against the GPC being IPL'd. Step 5 starts the IPL itself by pushing the IPL pb.

The MODE talkback goes to IPL while the initialization software is loaded. If this does not happen, then a mass memory I/O error has occurred and the other MMU should be tried. This step will take longer for vehicles with tape-type MMUs.

At this point, the GPC has just enough software to conduct the rest of the IPL and load the PASS system software by taking the GPC to STBY (step 6). Since no CRT is selected, the GPC defaults to a load of PASS software (copy 1 from the MMU). At this time the master alarm sounds and the GPC's CAM diagonal light is lit momentarily for tape-type MMUs, but not for SSMMs. These indications are nominal here and do not indicate a failure. When the talkback goes to RUN, the IPL is complete. Again, this step takes longer for tape-type MMUs.

The GPC is then ready to be moded to RUN and will be in OPS 0. It is assigned an IDP to ensure that it is running properly and can then be transitioned to any desired memory configuration. (In the case of a PASS recovery after BFS engage, the first PASS GPC to be IPL'd automatically takes control of any forward CRTs not commanded by the BFS upon being moded to RUN.) The IPL SOURCE switch is then turned off (step 9), and the software IPL SOURCE switch mask is reinstated.

Figure 3-74 shows the BFC CRT switches on Panel C3. Panel O6 is shown in Figure 3-75.

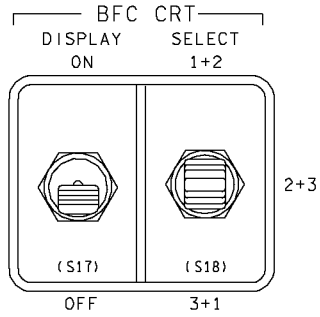

TD2920381.PNL

Figure 3-74. Panel C3

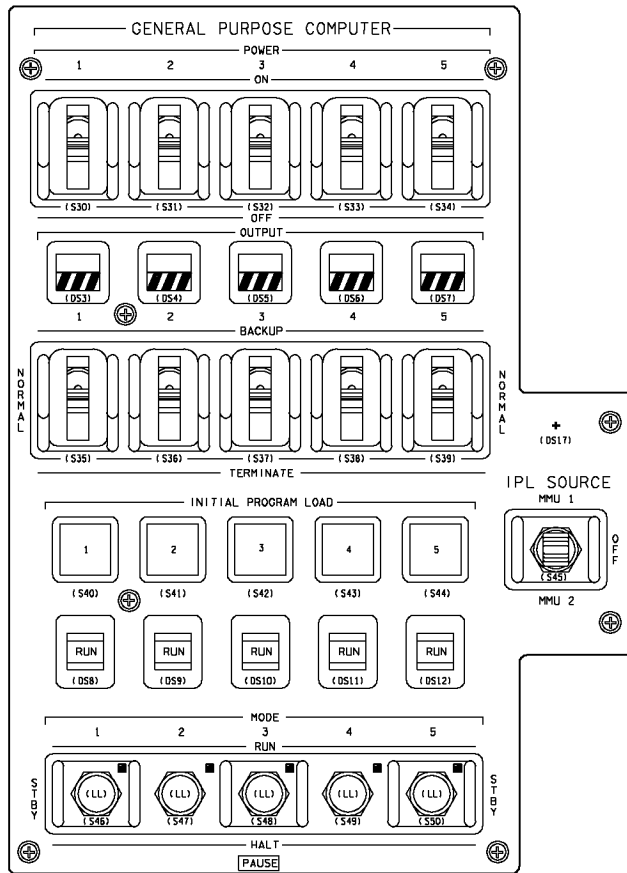

TD2920382.PNL

Figure 3-75. Panel O6

3.7.3 In-Flight Maintenance

The only way to recover from hardware failures that are not transients is to exchange the failed unit for a good one.

There are several procedures in the IFM Checklist for changing out elements of the DPS. They include swapping a failed forward CRT or keyboard with the aft one, swapping a good FF4 for another FF MDM that has failed (to get back an IMU), and swapping PL MDMs to recover payload bay door operations. After any of these changeouts are performed, a thorough checkout of the “new” unit is done, using procedures in the Malfunction Procedures Book.

4.0 BACKUP FLIGHT SOFTWARE

The PASS GPCs provide all GNC control during a mission. Even though there are four redundant PASS GPCs, there is always the possibility of a generic software failure that could cause a breakup of the RS or a loss of control of the vehicle. (A number of software problems have indeed been found in testing, in simulations, and in flight. Almost all of the problems found on the ground were also present in the software that had already flown on several flights before the discovery of the coding error.) Therefore, the fifth GPC is loaded with a different set of software known as the BFS. (The odds of there being a serious error in both the PASS and BFS flight software simultaneously are really quite small.) The BFS is designed to take over control of the vehicle, if necessary, during the critical phases of ascent and entry. To make this possible, the BFS monitors the PASS GPCs to keep track of the current state of the vehicle. Then if three or more PASS GPCs fail or an unexplained loss of control occurs, the BFS can be engaged (that is, take over control) by the press of a button.

The BFS also performs the SM functions during ascent and entry because all four PASS GPCs are operating in GNC.

By convention, BFS software is always loaded into GPC 5 preflight, but any of the five GPCs can be made the BFS GPC, if necessary.

This section of the training manual is designed to correspond to the topics in the PASS section for easy PASS/BFS comparisons. There is also an extra subsection explaining the BFS engage process.

4.1 CONCEPTS AND DEFINITIONS

4.1.1 Backup Flight Software

Since the BFS is intended to be used only in a contingency situation, its programming was made much simpler than the PASS. Only the software necessary to safely complete an ascent or entry, maintain vehicle control on orbit, and perform the SM function during ascent and entry (when there is no PASS SM) was included. This programming means that PASS has a number of functions/capabilities that BFS does not; therefore, all flight software used by the BFS can fit into one GPC at the same time. Another level of redundancy is achieved since the BFS GPC need never access mass memory. Of course, the BFS software is loaded onto the MMUs in case the BFS GPC has a hardware failure. Another GPC (remember, all five are identical) could then be loaded with BFS via a BFS IPL (menu option IPL).

As with the PASS, BFS consists of both system software and applications software.

4.1.1.1 System Software

The system software in the BFS performs basically the same functions as it does in the PASS. These functions include time management, PASS/BFS interface, MEDS

interface, input/output, uplink/downlink, and engage/disengage control. Again, the system software is always operating when the BFS GPC is not in HALT.

4.1.1.2 Applications Software

Like the PASS, the BFS has different major functions (GNC and SM), but all its applications software is resident in main memory at one time. In fact, the BFS can operate (process software) in both major functions simultaneously.

The GNC functions of the BFS are designed to provide backup capability for the critical phases of a mission. BFS supports the ascent phase beginning at MM 101 and the deorbit/entry phase beginning at MM 301. In addition, the various ascent abort modes are also supported by BFS (with the exception of contingency aborts). BFS provides only limited support for on-orbit operations via MM 106 or MM 301.

The BFS is designed to monitor everything the PASS does during ascent and entry, so it has the same major modes as the PASS in OPS 1, 3, and 6. However, these are the only OPS the BFS has (other than OPS 0) and the only times it can track the PASS.

BFS SM software provides a backup capability to the C&W subsystem. BFS SM contains that software necessary for supporting the dynamic phases of the mission: ascent and entry. It runs continually whenever the BFS GPC is in the RUN or STBY mode; however, the BFS does not have control of the PL buses when it is in STBY. Fault annunciation is still available via the CRT, but associated light and tone annunciation is inhibited. The SM major function in the BFS is not associated with any OPS. Unlike the PASS, BFS SM software is processed even when the BFS is in OPS 0 (on orbit), and the displayed OPS for a BFS commanded CRT in the SM major function is 000.

4.1.2 Displays

The BFS supports the same kind of OPS/SPEC/DISP display hierarchy in its software as does the PASS. The standard display features are identical to the PASS except that the second line of every display has the addition of the text "BFS," the mission timer displays only MET, and the CRT timer is held at zero in the SM and PL major functions. BFS CRT displays closely resemble PASS displays where it is practical; however, differences in requirements and capabilities have resulted in format differences.

Analogous displays in the BFS usually have the same number as they do in PASS.

The only BFS displays associated with system software are the BFS MEMORY (Figure 4-1) and BFS FAULT (Figure 4-2) displays. Both are available anytime. The BFS MEMORY display is the OPS 0 display or SPEC 0 in OPS 1, 3, or 6. The BFS FAULT display is called up via the FAULT key and is identical to the PASS FAULT display, except that it can display 20 messages (15 in PASS).

```

0001/ / BFS MEMORY XX X DDD/HH: MM: SS
BFS DDD/HH: MM: SS

READ/WRITE
DATA 1X BIT SET 3X SEQ ID 5
CODE 2X BIT RST 4X WRITE 6
7 ENG UNITS XXX HEX 8X
ADD ID DESTRED ACTUAL
9 XXXXX 10 XXXX ±XXXXXXXXXXXX
11 XXXXX 12 XXXX ±XXXXXXXXXXXX
13 XXXXX 14 XXXX ±XXXXXXXXXXXX
15 XXXXX 16 XXXX ±XXXXXXXXXXXX
17 XXXXX 18 XXXX ±XXXXXXXXXXXX
19 XXXXX 20 XXXX ±XXXXXXXXXXXX

MEMORY DUMP LAUNCH BUS 1 26X TFL ENA
21 START ID XXXXX 2 27X 29X
22 NUMBER WDS XXXXXX OFF 28X
23 WDS/FRAME XXX
DUMP 24 PASS/BFS XFER ENA 25X

BFS TIME UPDATES UPDATE 38 MISSION TIME
30 GMT Δ ±XXX/XX: XX: XX.XXX GMT 39X
34 MET Δ ±XXX/XX: XX: XX.XXX MET 40X

```

TD2920401. CRT# 1

Figure 4-1. SPEC 0 - BFS MEMORY display

```

0001/ /099 FAULT 5 000/00: 03: 59
BFS 000/00: 00: 00
TIME

CRT FAULT C/W GPC
ID
SM1 FC REAC 3 * 5 000/00: 03: 51
SM1 MAIN BUS V C 5 000/00: 03: 44
SM1 FC AMPS 3 5 000/00: 03: 44
SM1 DC VOLT FC 3 5 000/00: 03: 44
SM1 MAIN BUS V C * 5 000/00: 03: 44
MPS LH2/02 ULL 5 000/00: 03: 43
SM2 FREON FLOW 2 * 5 000/00: 02: 40
SM1 FC PUMP 3 * 5 000/00: 02: 39
SM2 HYD QTY 3 5 000/00: 02: 38
SM2 W/B QTY 2 5 000/00: 02: 37
SM2 AV BAY FAN 5 000/00: 02: 37
SM1 AC VOLTS 3 * 5 000/00: 02: 37
SM2 H2O PUMP P 2 * 5 000/00: 02: 37
SM2 H2O PUMP P 1 * 5 000/00: 02: 37
I/O ERROR CRT3 5 000/00: 02: 35
CE STRG 3 NSP 5 000/00: 02: 35
BCE STRG 4 ADTA 5 000/00: 02: 34
BCE STRG 3 ADTA 5 000/00: 02: 34
SM2 FREON FLOW 1 * 5 000/00: 0 : 54

BCE STRG 3 ADTA 5 00: 02 ( 17)
FAULT SUMM

```

5262. CRT# 1

Figure 4-2. BFS FAULT display

4.1.3 GPC Mode Switch

Even though the five GPCs and their switches are identical, the MODE switch on Panel O6 (Figure 4-3) works differently for a GPC loaded with BFS, especially in the STBY position.

Since HALT is a hardware-controlled state, this mode is the same for the BFS; i. e., firmware is executed. The same discrettes and switches are monitored to detect a change in mode or to perform an IPL.

The STBY mode is totally different for a BFS GPC. In this mode, all normal software is being executed just as if the BFS were in RUN. In fact, the only difference between STBY and RUN for a BFS GPC is that BFS command of the PL data buses is inhibited in STBY (similar to FC bus command inhibit via the TERM position of the OUTPUT switch). The BFS is put in STBY whenever a PASS SM GPC is operating and is normally put in RUN for ascent and entry. The BFS takes over command of the PL data buses from an SM GPC if moded to RUN while one is operating. Note that whether the BFS is in STBY or in RUN, it takes control of the FC and PL data buses if engaged.

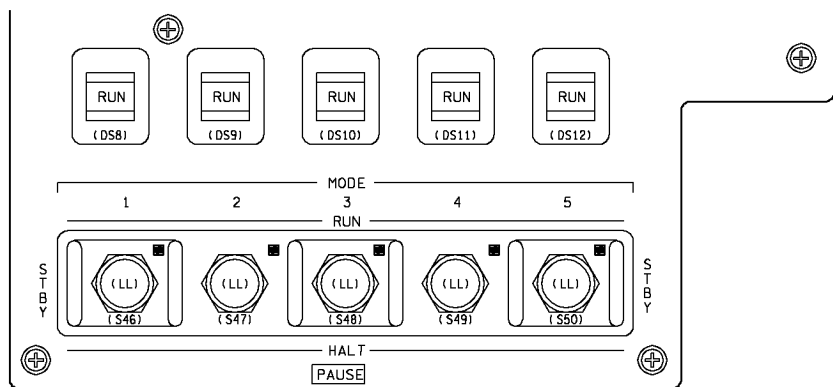

TD2920403. PNL 1

Figure 4-3. Panel O6

The MODE tb for the BFS GPC works much more simply than for the PASS. If the BFS GPC is in RUN or STBY, the tb is in RUN. It is barberpole if the BFS is in HALT or has failed.

4.1.4 Synchronization

In order for the BFS to track the PASS and keep up with its flow of commands and data, the BFS is synchronized with the PASS. This synchronization and tracking are done during OPS 1, 3, and 6. During this time, the BFS listens over the FC data buses to the requests for data by the PASS and to the data coming back. The BFS also listens to all DK buses (CRTs) all the time and monitors some inputs to PASS IDPs (DK listen). It updates its own GNC parameters accordingly.

Of course, the BFS is never a member of a CS or an RS, so it is always a simplex GPC.

4.1.5 Data Bus Assignment

If the BFS GPC is tracking the PASS GPCs, the BFS GPC cannot command over the FC buses, but does listen to FC data via the selective transaction listen mode interface. The BFS may acquire port moding data and bypass data via the PASS to BFS transfer data over the FC5 to 8 buses (sent out cyclically by PASS for BFS use).

Each GPC has a dedicated IP data bus through which it can receive OI data and transmit its downlist to the ground. So, the BFS controls its own IP data bus. The BFS GPC ICC data bus is not used at all. The MMU data buses are not used by the BFS except at IPL, and assignment is via the same IPL SOURCE switch used for a PASS IPL.

During ground checkout, when the PASS is in GNC OPS 9, the ground support can perform checks of the BFS by polling it via a launch data bus. To do so, it is necessary first to deassign the launch data bus from the PASS with SPEC 0 and an OPS/mode recall in GNC OPS 901 and then to give BFS command of an LDB (nominally LDB 1) via BFS SPEC 0, item 26 (refer to Figure 4-4).

```

0001/ / BFS MEMORY XX X DDD/HH: MM: SS
BFS DDD/HH: MM: SS

READ/WRITE
DATA 1X BIT SET 3X SEQ ID 5
CODE 2X BIT RST 4X WRITE 6
7 ENG UNITS XXX HEX 8X
ADD ID DESIRED ACTUAL
9 XXXXX 10 XXXX ±XXXXXXXXXXXX
11 XXXXX 12 XXXX ±XXXXXXXXXXXX
13 XXXXX 14 XXXX ±XXXXXXXXXXXX
15 XXXXX 16 XXXX ±XXXXXXXXXXXX
17 XXXXX 18 XXXX ±XXXXXXXXXXXX
19 XXXXX 20 XXXX ±XXXXXXXXXXXX

-----
MEMORY DUMP
21 START ID XXXXX
22 NUMBER WDS XXXXXX
23 WDS/FRAME XXX
DUMP 24

LAUNCH BUS 1 26X TFL ENA
2 27X 29X
OFF 28X

PASS/BFS XFER ENA 25X

BFS TIME UPDATES UPDATE 38 MISSION TIME
30 GMT Δ [±]XXX/XX: XX: XX.XXX GMT 39X
34 MET Δ [±]XXX/XX: XX: XX.XXX MET 40X

```

TD2920404. CRT: 1

Figure 4-4. BFS MEMORY display

Control of the PL data buses is determined by the BFS MODE switch, as explained before, and control of the DK buses is determined by the BFC CRT switch and the GPC/CRT key. See Figure 4-5. (One important thing to remember is that all GPC/CRT key entries, even if they are for the BFS, should be made to a PASS-commanded CRT. BFS does DK listen and hears about it. PASS does not DK listen to BFS-commanded

CRTs and would not hear such an entry. This configuration avoids the possibility of CRT dual commanders.)

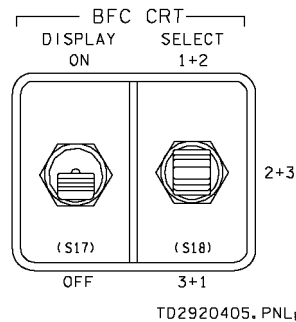

Figure 4-5. Panel C3

4.1.6 Memory Configuration

Since all BFS software is resident in main memory all the time, there is no need for separate memory configurations to be loaded in from an MMU. Also, there are no NBATs associated with the BFS since it always commands all the buses appropriate to the conditions.

4.1.7 Memory Reconfiguration

Although no new software is ever loaded into a running BFS GPC, not all the resident software is being processed at once. The BFS is transitioned to OPS 1 and OPS 3 just as the PASS is with an OPS XXX PRO to a BFS keyboard. The BFS also follows the PASS through the major modes in OPS 1, 3, and 6 by DK listening to hear when the PASS is transitioned.

Whatever the status of GNC in the BFS, the SM software is processing (i.e., even in OPS 0).

A major difference between the PASS and BFS is that the BFS can be transitioned from OPS 0 into OPS 1 or 3 at any time (i.e., in a recovery procedure), even during the middle of an ascent or entry. The BFS looks at some transfer data from PASS, when first moded into OPS 1 or 3 to pick up the current status (e.g., state vector). However, it does look at the PASS port moding status whenever an I/O RESET EXEC is done to it. The BFS is taken to OPS 0 by an OPS 000 PRO keyboard entry and always comes up in OPS 0 when moded from HALT to RUN or STBY.

4.1.8 Checkpoint

The BFS does not have the capability to take checkpoints. However, parameters can be changed by the ground just as they can for the SM GPC via BFS TMBUs.

4.2 SYNCHRONIZATION AND GPC REDUNDANCY MANAGEMENT

4.2.1 Tracking the PASS

Since the BFS is never in a CS or an RS with other GPCs, it does not exchange information or maintain RM schemes like the PASS. However, before the BFS is engaged and takes control of the FCs, it is dependent upon the PASS GPCs for all its GNC data. Therefore, the BFS maintains a listen mode over the FC data buses. To do this, it must be synchronized with the PASS GPCs to know when to receive GNC data over those buses. When the BFS is in sync and listening to at least two strings, it is said to be tracking the PASS.

As long as the BFS is in this mode, it maintains the current state vector and all the other information necessary to fly the vehicle if the crew needs to engage the BFS. The BFS can track the PASS only when PASS is in GNC OPS 1, 6, or 3. If any PASS GPCs fail to sync, the BFS continues to track the strings commanded by the remainder of the RS.

4.2.2 Standalone BFS

If any of the above conditions are not met, the BFS stops tracking the PASS (goes standalone). In this mode, the BFS is getting no data over the FCs, so it goes on internal time and propagates its own state vector from its last known position and velocity. Therefore, in dynamic flight there is not much time before the BFS state vector is not usable. During ascent, it is only about 10 seconds after the BFS goes standalone; for the lower accelerations during entry, it is 45 seconds. (These values are from the Flight Rules; actual values can vary, depending on the specific scenario.)

The BFS goes standalone if it loses sync with the PASS for some reason or if the BFS is not tracking at least two strings. An FC bus I/O error that occurs as a result of a GPC problem (whether PASS or BFS) causes the BFS to drop that entire string and annunciate a BCE STRGx PASS fault message.

For example, if during ascent GPC 1 has a problem with its transmitter for the FC1 data bus, MDM FF1 no longer hears requests for data and stops sending any. Since no PASS GPCs receive anything from FF1, they agree on an I/O ERROR FF1. However, since the BFS was listening to the requests for data, it recognizes a GPC problem and masks the entire string (both FF1 and FA1) with a BCE STRG 1 PASS message. The same would be true of the BFS if it had a problem with its FC receiver; however, in this case the PASS would see nothing wrong, since it never listens to the BFS.

4.2.2.1 BFC Light

There is a BFC light on the “eyebrow” Panels F2 and F4 (see Figure 4-6). It remains unlit as long as the PASS is in control and the BFS is tracking it. The light flashes if the BFS loses track with the PASS and goes standalone. When this happens, the crew must decide whether to engage the BFS now, before its state vector degrades, or whether to try to get it tracking again. An I/O RESET EXEC to the BFS recovers transient failures. Sometimes, it is necessary to take the BFS to OPS 0 and then PRO it back into the current major mode (in sequence). The light is extinguished when the BFS is tracking again or the BCE STRGx PASS messages are acknowledged. In the case of a BFS engage, once the BFS is in control, the BFC light comes on and stays lit (no flashing) until disengage.

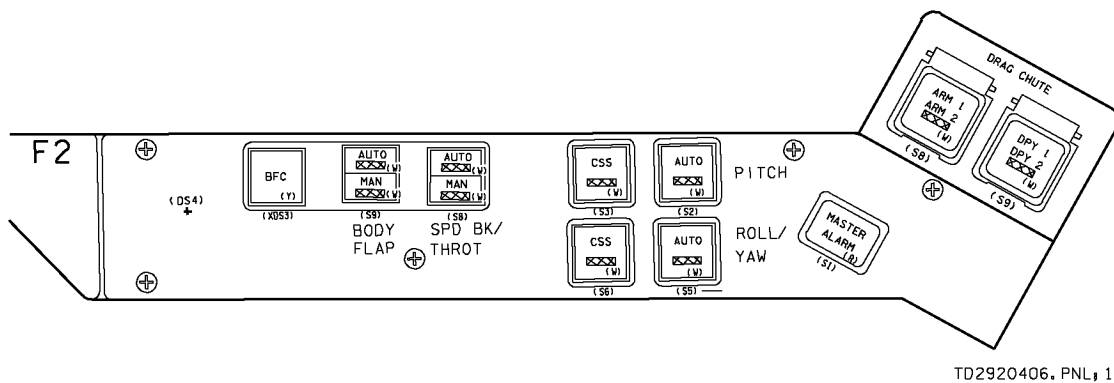

Figure 4-6. Panel F2

4.2.3 BFS GPC RM and Annunciations

4.2.3.1 CAM Lights

Since the BFS does not operate in a set, its discrete inputs and outputs, which are fail votes for and against other GPCs, are not used. However, the BFS can set its own self-fail vote and light its diagonal (I-fail) CAM light (also triggering a Master Alarm). As described in the hardware section, if the watchdog timer in the BFS GPC ever times out (e.g., if the CPU fails or the software gets caught in an endless loop), the BFS sets its self-fail indication. There is also logic that checks if the BFS completes its cyclic processing. This kind of failure also causes the diagonal CAM light to be lit. These are the only ways the BFS can activate the CAM.

4.2.3.2 Fault Messages

The BFS can recover from power transients or transient hardware problems by doing a restart of the software and coming back up in the major mode it was processing before the problem. In these cases, the BFS may annunciate a GPC PWR FAULT message (which is unique to BFS) or a GPC BITE message (also available in PASS). If the BFS GPC experiences the transient presence of a HALT discrete, it enters OPS 0. At this point, the crew has to manually PRO it back to the former OPS and major mode.

4.2.3.3 Mode Talkback

Aside from CRT displays, the only way to tell if the BFS is still running is the MODE tb on Panel O6 (Figure 4-7). This tb should always be checked if the BFS loses its CRT interface for some reason. It goes bp if the BFS has failed to HALT. Of course, the OUTPUT tb is always bp until and unless the BFS is engaged. If the BFS software gets caught in an endless loop (called a “software quit” failure), the MODE tb does not go to bp. The watchdog timer times out and turns on the BFS GPC’s I-fail CAM light, however.

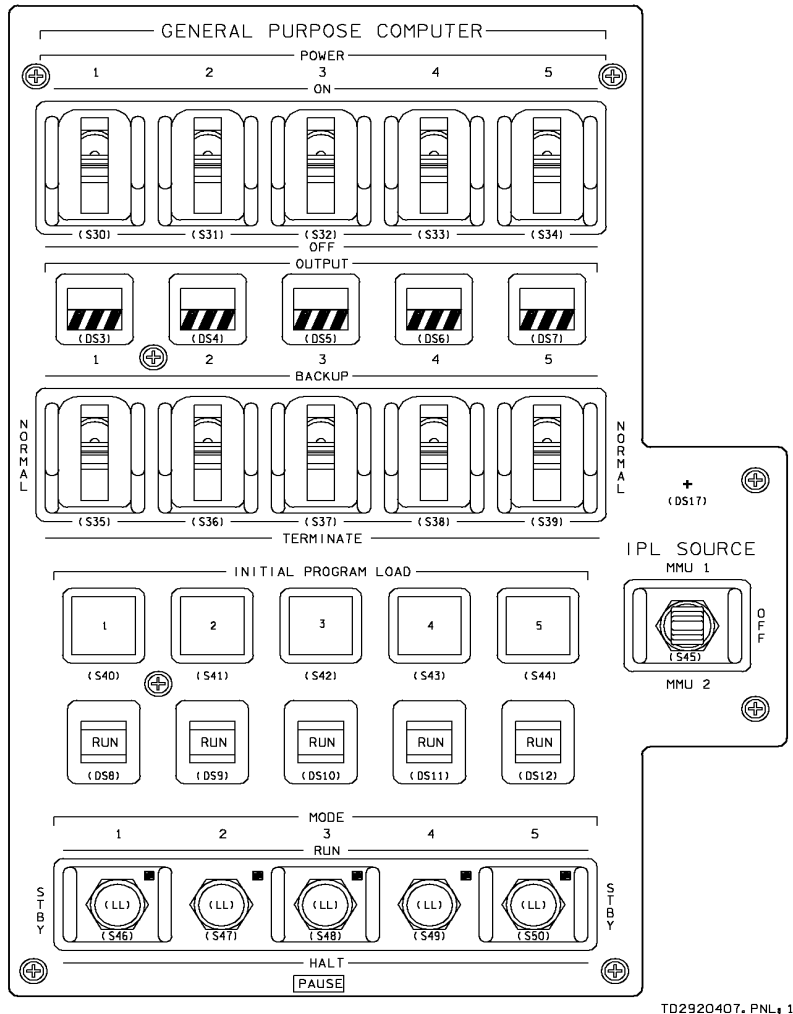

Figure 4-7. Panel O6

4.2.4 BFS Fail Procedures

During the powered flight portion of ascent, since the BFS does not have control of any FC data buses, it is not necessary to mode it to HALT right away after a failure. However, the procedures do have the crew give BFS CRTs to the PASS and mode the BFS to HALT, post-MECO.

Once on orbit, the GPC FAIL procedures are mostly the same as for PASS FAIL. Another GPC is made a BFS GPC and the failed GPC is dumped and then made the redundant G2 PASS GPC, if recovered after an IPL. The only difference is that, whenever a new BFS GPC is IPL'd, its software contents are dumped to the ground for verification.

During the coasting flight portion of ascent and during entry, the pocket checklist (Figure 4-8) has the crew attempt recovery of the BFS by taking it back to RUN to see if it reinitializes. If it does, the crew then PROs it on to the same major mode as PASS. If only the SM function of the BFS is working (the BFS does not track the PASS), the BFS is placed in STBY so that control of the PL buses goes to PASS. If it does not recover at all, it is placed in HALT. If BFS does not recover fully, its OUTPUT switch is placed in TERM to prevent an inadvertent engage. The crew is then advised that, if there are communications problems, it is probably because the BFS cannot select the proper antenna any more; therefore, the crew is advised to do so manually. The last two steps of the procedure have the crew manually perform actions that the BFS commands automatically when it is working properly.

- BFS GPC FAIL**
- ⇒
1. GPC MODE – STBY, HALT, pause
– STBY, RUN
 2. If recovered: PRO to OPS 304
BFS G50 ✓BFS R/W sel
✓GPC OUTPUT – B/U >>
 3. If SM only: GPC MODE – STBY, then step 5
 4. GPC MODE – HALT
 - ◇ 5. OUTPUT – TERM
 6. If no comm: Sel best S-BD PM ANT
 7. MPS He ISOL B (three) – CL
PNEU He ISOL – CL
 8. If AOA/GRTL/TAL < 120K:
NH3 CNTLR B – SEC/ON

Figure 4-8. Entry Pocket Checklist

4.3 INPUT/OUTPUT MANAGEMENT

Since the BFS has to take over control of the vehicle in the event of a PASS failure, it is designed to have I/O management of the FC data buses very similar to PASS. Prior to being engaged, the BFS has no control over the FCs but is constantly aware of the status of I/O errors by listening to what the PASS is doing over those buses, including I/O transactions and any bypasses set by the PASS. Postengage, the BFS takes command of the FC data buses (as well as the payload buses if it is in STBY) and a second IDP. The BFS then begins conducting I/O transactions and processing error detection just like the PASS did.

4.3.1 PASS to BFS Transfers

4.3.1.1 DK Listen

Besides the listen mode on all FC data buses, a selective DK listen interface exists that allows the BFS to acquire manual sequencing data and certain display data from PASS-controlled DK buses. Selected items on the XXXX MNVR XXXX, HORIZ SIT, and ENTRY TRAJ X displays and any GPC/CRT key inputs are monitored via DK listen. The BFS processes these keyboard requests as if they were made to a BFS keyboard in order to lessen the number of dual keyboard commands needed. Therefore, BFS gets targets loaded and proceeds through major modes without duplicate keystrokes.

4.3.1.2 Snapshot Transfer

A snapshot transfer is a transfer of data representing a snapshot or frozen look at data for a particular time. Data, which are snapshot from cyclic PASS transfer data, include relative velocity at the time of a main engine failure (OPS 102 to 103) and the PASS state vector upon transition from BFS OPS 0 to OPS 301. The capability also exists to snapshot the state vector on command. The BFS HORIZ SIT display (see Figure 4-9) available in BFS OPS 1, 3, and 6 contains an item entry to command a one-time snapshot of the PASS state vector (item 17).

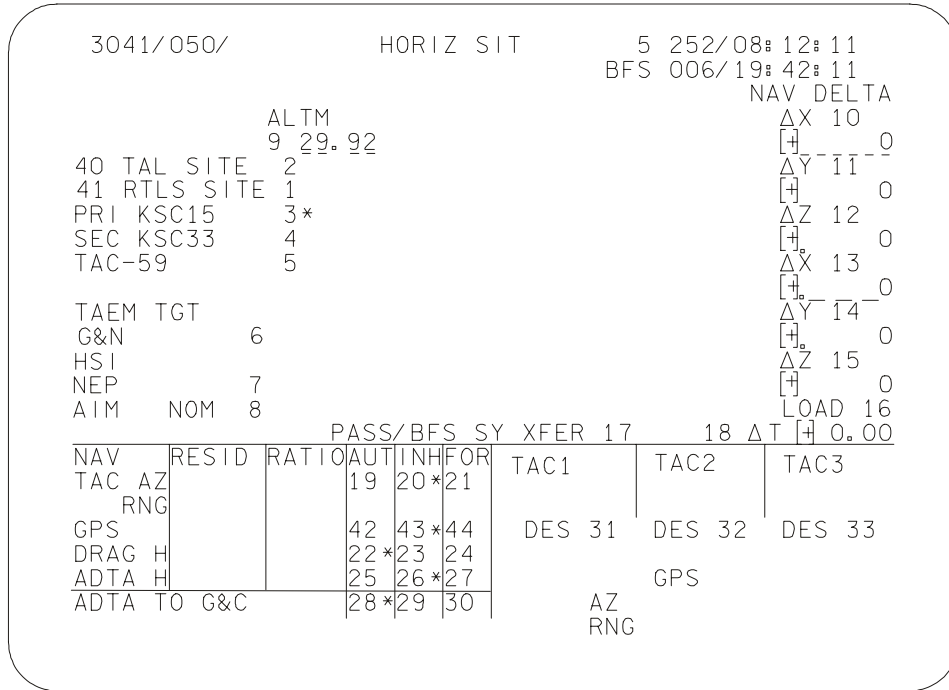

TD2920409. CRT: 3

Figure 4-9. SPEC 50 - BFS HORIZ SIT display

4.3.1.3 One-Shot Transfer

Certain initialization-type data, in addition to the cyclic data, is required by the BFS. This is accomplished by what is known as the one-shot transfer. Unlike the cyclic data transfer, the one-shot transfer does not request the BFS to have acquired PASS tracking.

A one-shot transfer is sent by the PASS to the BFS prior to launch before the PASS modes to OPS 1. At this time, the BFS is operating in a disengaged standalone state in OPS 0, and the PASS is in GNC OPS 9. To accomplish the transfer, the BFS must be set up to listen for the one-shot transfer of data. This is done in the ascent checklist at T - 32 minutes (see Figure 4-10). The BFS is brought up to OPS 0 by moding it to STBY (same as RUN except for PL data bus control) and then it is assigned a CRT. The BFS is then told to listen for the one-shot transfer via item 25 (PASS/BFS XFER ENA) on BFS MEMORY in Figure 4-11. An asterisk appears beside item 25.

```

-32:00 C PASS/BFS TRANSFER PREP
(-1:22:00)
O6  ✓GPC MODE 5 - STBY (tb-RUN)
C3  ✓BFC CRT SEL - 3+1
    DISP - ON

3: GNC BFS MEMORY
CRT3 PASS/BFS XFER ENA - ITEM 25 EXEC
    ✓ITEM 25 (*)

```

Figure 4-10. Ascent Checklist

```

0001/ / BFS MEMORY XX X DDD/HH:MM:SS
                                BFS DDD/HH:MM:SS
READ/WRITE
DATA 1X BIT SET 3X SEQ ID 5
CODE 2X BIT RST 4X WRITE 6
7 ENG UNITS XXX HEX 8X
ADD ID DESIRED ACTUAL
9 XXXXX 10 XXXX ±XXXXXXXXXXXX
11 XXXXX 12 XXXX ±XXXXXXXXXXXX
13 XXXXX 14 XXXX ±XXXXXXXXXXXX
15 XXXXX 16 XXXX ±XXXXXXXXXXXX
17 XXXXX 18 XXXX ±XXXXXXXXXXXX
19 XXXXX 20 XXXX ±XXXXXXXXXXXX

MEMORY DUMP | LAUNCH BUS 1 26X TFL ENA
21 START ID XXXXX | 2 27X 29X
22 NUMBER WDS XXXXXX | OFF 28X
23 WDS/FRAME XXX | PASS/BFS XFER ENA 25X
DUMP 24

BFS TIME UPDATES UPDATE 38 MISSION TIME
30 GMT Δ ±:XXX/XX:XX:XX.XXX GMT 39X
34 MET Δ ±:XXX/XX:XX:XX.XXX MET 40X

```

TD2920411. CRT# 2

Figure 4-11. BFS MEMORY display

The actual transfer is done 10 minutes later by the ground via IDP equivalent commands. The PASS GTS DISPLAY (SPEC 100) (Figure 4-12) is called up, and item 15 is executed by the ground. The crew can then check that the asterisk is gone from item 25 on BFS MEMORY. The data transferred includes IMU bias compensations and other parameters needed for flight.

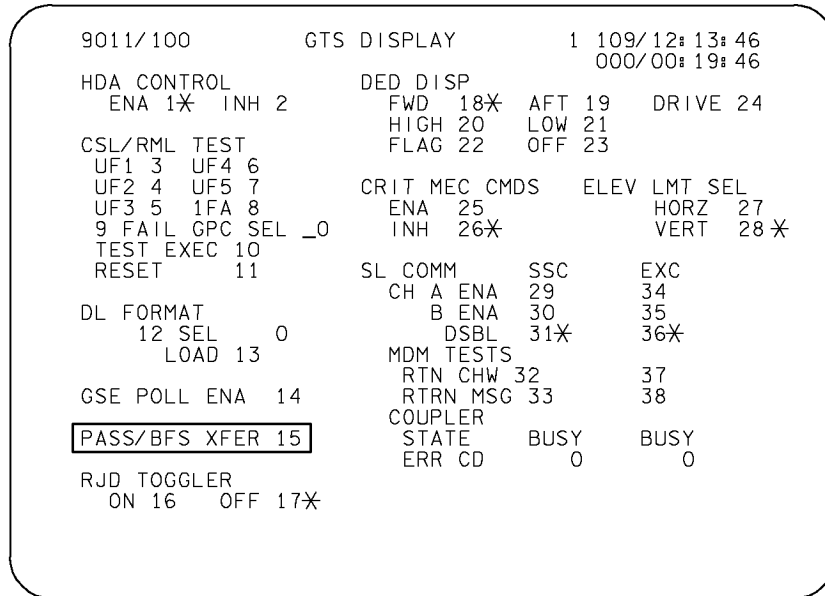

TD2923013, CRT: 1

Figure 4-12. SPEC 100 - GTS DISPLAY (PASS)

4.3.2 I/O Error Handling

4.3.2.1 Preengaged

The I/O error handling by BFS is similar to the PASS error handling in the preengaged state. PASS transfer data concerning I/O errors is incorporated into the BFS I/O error logic, if the BFS is tracking the PASS. Both the PASS and the BFS GPCs set bypasses and annunciate BCE or MDM port failures. If BFS determines a data path to be failed due to loss of listen (i.e., loss of PASS GPC outputs), the BFS downmodes the entire string. BFS also drops the entire string if it disagrees on the bypass status of even one BCE element for two consecutive cycles. This type of string downmoding can occur if a PASS GPC fails-to-sync with the other PASS GPCs or a malfunction causes the BFS to lose its associated FC data bus MIA. If either of these failures occurs, a class 3 message BCE STRGx PASS (X = string no.) is annunciated. M's in the appropriate FF and FA MDM columns are displayed on the GNC SYS SUMM 1 display, as shown in Figure 4-13.

The BFS also detects and annunciates CRT, PL MDM, and PCMMU I/O errors independently of PASS sync.

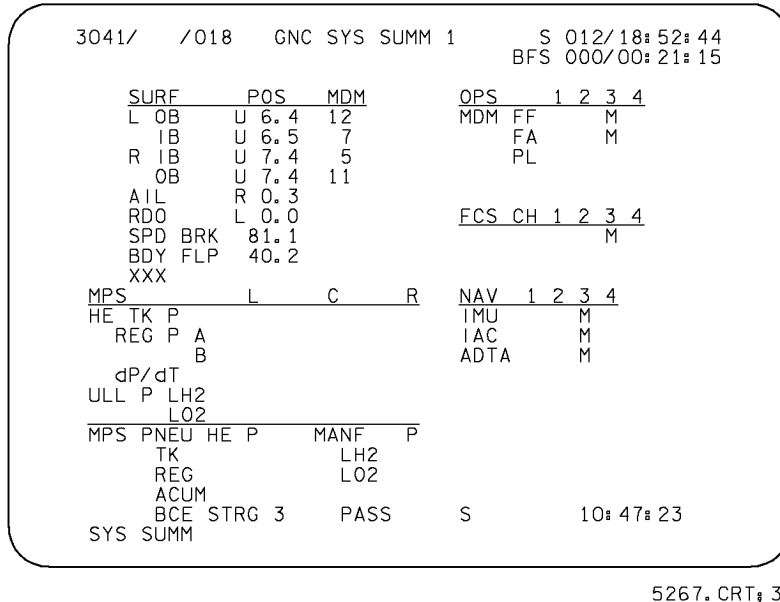

Figure 4-13. BFS GNC SYS SUMM 1 display

4.3.2.2 Engaged

The BFS I/O error handling, when it is in control of the FC data buses, is the same as it was preengaged, except that PASS data is no longer processed and string downmoding is not performed. All BCE bypasses on the FCs that can be done by the PASS can also be done by the BFS (except Microwave Landing System (MLS) and Star Tracker (STKR)). BTU bypasses on the FC MDMs, CRTs, PL MDMs, and PCMMU (with I/O ERROR messages) can also be done by the BFS. Of course, when the BFS is the only GPC active, there is no way to distinguish GPC-caused I/O errors from BTU-caused I/O errors.

4.4 BUS MASKING

The BFS performs bus masking when it stops listening to a string controlled by the PASS. It always downmodes both buses of a string whenever it sets a BCE STRGx PASS indication. Besides the fault message, there are down arrows and M's on BFS GNC SYS SUMM, as shown in Figure 4-13.

Since there are no other GPCs controlling buses after a BFS engage (except possibly a PASS CRT during PASS recovery procedures on orbit after a BFS engage during ascent), the engaged BFS performs no bus masking.

It should be noted here that the PASS GPCs set masks on all the buses being commanded by the BFS after engage. (Only PASS GNC GPCs shut themselves down and go to HALT when the BFS is engaged. An SM GPC would keep running, for example.)

These bus masks remain in effect until the BFS is disengaged.

4.4.1 Resetting Comm Faults

The BFS can reset BCE and MDM bypasses similar to the PASS when error conditions are cleared.

- I/O RESET EXEC to a PASS keyboard causes the BFS to reset all bypasses reset by the PASS when the BFS is tracking PASS (based on changes in the PASS bypass transfer data).
- I/O RESET EXEC to a BFS keyboard causes the BFS to attempt PASS tracking on all strings preengaged. Postengaged, it causes the BFS to retry all transactions, just like PASS.
- An automatic I/O reset is performed when BFS is transitioned to OPS 1 or 3.
- An automatic string upmode is performed when the BFS is engaged. The BFS, therefore, recovers all strings lost due to PASS GPC errors.

4.4.2 Port Moding

4.4.2.1 Preengaged

If port moding is done in the PASS, the BFS first drops the string in question. It will then update its port mode status to the same as the PASS with an I/O RESET EXEC to a BFS keyboard. BFS then resumes tracking of the affected string.

4.4.2.2 Engaged

There is no port moding capability via the BFS.

4.4.3 Mass Memory I/O Management

After being IPL'd, the BFS GPC has no interface with the MMUs or MM data buses, either preengage or postengage.

4.4.4 DK I/O Management

4.4.4.1 DK Assignment

The usual method used to assign IDPs to the BFS is via the BFC CRT switches on Panel C3 (Figure 4-14). The DISPLAY switch has two positions, ON and OFF. For the OFF position, no IDP is designated for the BFS, and for the ON position, BFS IDP selection is controlled by the BFC CRT SELECT switch. The SELECT switch has three positions designated as 1 + 2, 2 + 3, and 3 + 1. The first number indicates which IDP is dedicated to the BFS in the preengaged state, and the second number indicates which IDP joins the first in a postengaged state. If the BFC CRT DISPLAY switch is OFF when the BFS is engaged, BFS automatically takes control of IDPs 1 and 2. It should be noted that this switch overrides any attempts to assign an IDP to the PASS via the GPC/CRT key.

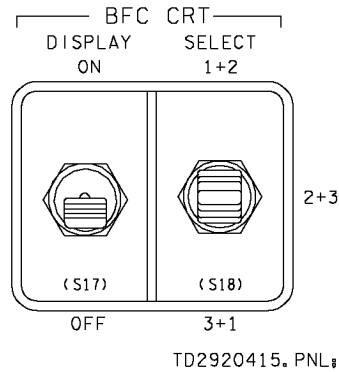

Figure 4-14. Panel C3

The GPC/CRT key is the only other method to assign an IDP to the BFS, with the intention of being a backup to the BFC CRT switches. If an IDP in addition to the one designated by the switch is to be assigned to the BFS or if the switch is not working properly, a GPC/CRT 5X EXEC is entered on a PASS keyboard (Figure 4-15). It is imperative that this be done on a PASS CRT because the PASS does not DK listen to the BFS and dual IDP commanders would result if the input is made to a BFS CRT. (Note that the PASS does not transfer IDP control to the BFS as such, it merely gives up control since 5 is not a number of a common set GPC. GPC 5 hears the input and assumes control itself.)

The GPC/CRT key is always used to assign the third forward IDP to the BFS after engage.

It should be pointed out here that an IDP assigned to the PASS before the BFC CRT DISPLAY switch is turned on still counts against the PASS three-IDP limit. (The BFS can control all four IDPs simultaneously.)

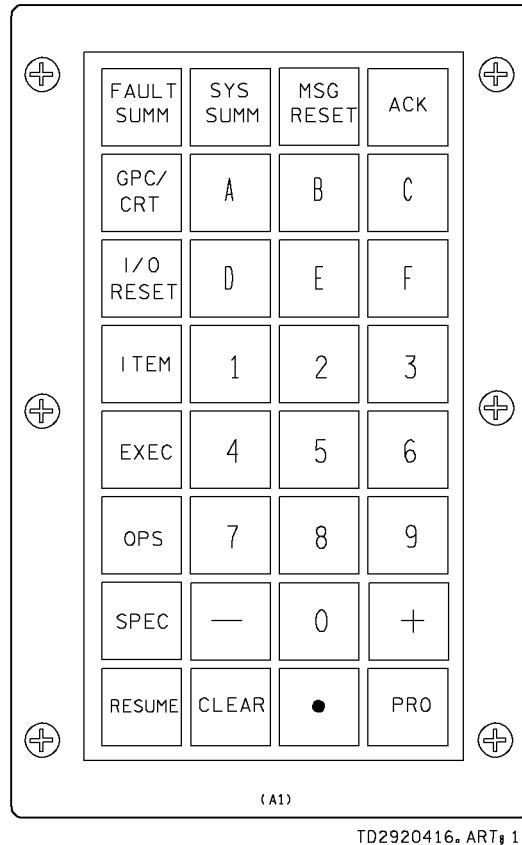

Figure 4-15. Keyboard

4.4.4.2 Error Handling

Error handling for the MEDS is basically the same for the BFS as for the PASS. Since BITE is a function of the IDP and not the GPC, the MEDS MAINT display also works the same. The only difference is that BFS issues a CRT BITE message against any IDP when it is powered on or power cycled because the BFS is not programmed to recognize the unique IDP BITE pattern associated with IDP powerup. PASS does recognize this pattern and does not issue the message for powerup.

4.5 TIME MANAGEMENT

4.5.1 Time Source Selection

4.5.1.1 Preengage

In order to process GNC software along with the PASS, the BFS must be in sync with PASS timing. Therefore, BFS uses the MTU just as PASS does, although it may well be using a different one of the three accumulators.

The MET of the BFS GPC does not count down to liftoff as it does for the PASS. BFS MET is an echo of the MTU MET and is held at zero during OPS 0 and MM 101. At

transition to MM 102 (SRB chamber pressure > 50 psi), the MTU MET timekeeping is initialized. BFS also starts using MTU MET, along with GMT, at transition from OPS 0 to OPS 3.

4.5.1.2 Engaged

Postengage the BFS takes control of the FCs and polls the MTU directly. The BFS checks for I/O errors, chooses an accumulator via midvalue select, and uses that GMT. The BFS does a tolerance test, as does the PASS, and downmodes to another accumulator or internal time as required.

4.5.2 Time Updates

If the BFS time needs to be changed, it can be done via items 30-38 on the BFS MEMORY display. Also, if a GMT update is done to the PASS, the BFS stops tracking and an I/O reset is required to reestablish tracking.

Items 39 and 40 select the BFS CRT time to GMT or MET, respectively.

4.5.3 CRT Timers

The MNVR displays are the only BFS displays available in which the CRT timer is functional. The timer counts down to (and then up from) TIG after being set via item 23 on either the BFS MNVR display (Figure 4-16) or the PASS MNVR display during DK listen.

There are no alert tone controls in the BFS.

```

1041/          OMS 1 MNVR EXEC          5 123/14: 32: 21
OMS BOTH 1*   BURN ATT                   BFS 000/00: 01: 21
  L 2
  R 3
RCS SEL 4
5 TV ROLL 180
TRIM LOAD    MNVR 27
6 P [+0.4
7 LY[-35.7
8 RY[+5.7
9 WT 262929
10 TIG
   L           R
   P +0.3     +0.3
   Y -5.6     +5.6
TGT PEG 4
14 C1
15 C2 [+0.0000
16 HT 158.795
17 -T 163.123
18 PRPLT [ ]
TGT PEG 7
19 AVX [ ]
20 AVY [ ]
21 AVZ [ ]
LOAD 22/ [ ]
TIMER 23
          TTA 04: 15
          GMBL
          HA      HP
          TGT 153 + 34
          CUR 63 - 140
          ΔVTOT 645.0
          TGO 07: 04
          VGO X + 598.66
          Y+ -44.14
          Z + 236.17
          35 ABORT TGT _Q
          FWD RCS
          ARM 36
          DUMP 37
          OFF 38*
          SURF DRIVE
          ON 39
          OFF 40*

```

TD2923017. CRT: 1

Figure 4-16. BFS MNVR display

4.6 GPC READ/WRITE

The top portion of the BFS MEMORY display (Figure 4-17) is just like the READ/WRITE portion of the PASS GPC MEMORY display and works exactly the same way for all read/write functions. (The only difference is the item numbers.)

This display is available as the OPS 0 display in GNC or as SPEC 0 in SM or GNC OPS 1, 3, and 6.

```

0001/ / BFS MEMORY XX X DDD/HH: MM: SS
BFS DDD/HH: MM: SS

READ/WRITE
DATA 1X BIT SET 3X SEQ ID 5
CODE 2X BIT RST 4X WRITE 6
7 ENG UNITS XXX HEX 8X
ADD ID DESIRED ACTUAL
9 XXXXX 10 XXXX ±XXXXXXXXXXXX
11 XXXXX 12 XXXX ±XXXXXXXXXXXX
13 XXXXX 14 XXXX ±XXXXXXXXXXXX
15 XXXXX 16 XXXX ±XXXXXXXXXXXX
17 XXXXX 18 XXXX ±XXXXXXXXXXXX
19 XXXXX 20 XXXX ±XXXXXXXXXXXX

MEMORY DUMP LAUNCH BUS 1 26X TFL ENA
21 START ID XXXXX 2 27X 29X
22 NUMBER WDS XXXXXX OFF 28X
23 WDS/FRAME XXX
DUMP 24 PASS/BFS XFER ENA 25X

BFS TIME UPDATES UPDATE 38 MISSION TIME
30 GMT Δ ±:XXX/XX: XX: XX.XXX GMT 39X
34 MET Δ ±:XXX/XX: XX: XX.XXX MET 40X

```

TD2920418. CRT: 1

Figure 4-17. BFS MEMORY display

4.6.1 Downlist

The BFS downlist operates like the PASS downlist and is included in the operational downlink to the ground whenever the BFS GPC is operating and the active TFL supports reading toggle buffer 5.

4.6.2 Composition of the Downlist

The BFS downlist differs from that of a PASS GPC in that it contains both GNC and SM data at the same time, as well as system software information. During ascent and entry, the GPC-derived SM data received by the ground comes from the BFS GPC, which is also sending its GNC data.

Like the PASS, the BFS downlists many of its discrettes, the current CRT display number and scratch pad line, GMT, and the last five fault messages, and sends all of this GNC, SM, and DPS data whether it is engaged or not.

The BFS also supports a set of three variable parameters, selectable only via uplink.

4.6.3 BFS Downlist/PCMMU Interface

The BFS sends its downlist to the PCMMU over its dedicated IP data bus. The control logic in the PCMMU routes the BFS downlist through toggle buffer 5 (even if the BFS is not in GPC 5). Unlike the PASS, the crew has no control over which toggle buffer is used for BFS downlist. How the BFS downlist is combined with the PASS downlist and payload and instrumentation data is determined by the selected telemetry formatter and TFL.

4.6.4 Telemetry Format Load

The BFS has no capability analogous to SPEC 62 in the PASS for changing the TFLs in the PCMMU. Likewise, if the BFS is engaged, the fixed or program format can be selected only via the OI PCMMU FORMAT switch on Panel C3 (Figure 4-18).

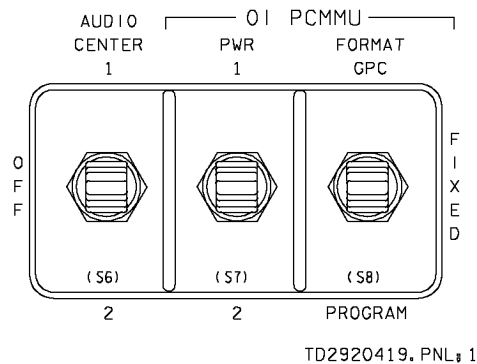

Figure 4-18. Panel C3

However, the BFS does have a special capability for loading a specified Low Data Rate (LDR) (64 kbs) TFL during ascent or entry. Since the LDR formatter does not operate in fixed format, the capability to automatically load a program TFL upon switchover to the other PCMMU is included in the BFS.

The controls to enable or inhibit this function are on the BFS MEMORY display, SPEC 0 (refer again to Figure 4-17). Item 29 - TFL ENA is initialized on and subsequent executions toggle the asterisk on and off. When item 29 is enabled, the BFS automatically initiates a LDR telemetry format load when a power switchover to the other PCMMU is detected. If an error is detected in the load, a class 3 fault message, TFL LOAD FAIL, is generated. The power switchover is accomplished manually by the crew by changing the OI PCMMU PWR switch on Panel C3. Note that this LDR format is stored in the BFS GPC main memory and does not require the MMUs.

4.6.5 Loss of Downlist

Like the SM GPC, the BFS gets OI data from the PCMMU. Therefore, the BFS can also detect PCMMU interface problems and annunciate I/O ERROR PCM fault messages. Unlike the SM GPC, BFS does automatic retries to reacquire PCMMU I/O if it is lost. Thus, an I/O ERROR PCM message is annunciated for transient loss of PCMMU I/O, but the data is restored to the BFS CRT as soon as the problem clears up. In case of a BFS PCMMU I/O error or loss of BFS downlist as seen by the ground, the crew selects the other PCMMU via the OI PCMMU PWR switch on Panel C3 to restore BFS downlist during ascent or entry. This action causes loss of the programmed High Data Rate (HDR) format, but all SM data comes from the BFS during those phases and there is no other way to restore the BFS downlist. If such an error occurs on orbit, the crew consults with the MCC on whether to switch PCMMUs.

4.6.6 Memory Dumps

4.6.6.1 BFS Software Memory Dump

Due to the criticality of the BFS GPC and the absence of BFS GPC RM, it is important to ensure that the BFS GPC has a good software load. Therefore, if the BFS GPC fails and BFS is IPL'd into another GPC, the contents of the new BFS GPC are software dumped to the ground for verification.

The software memory dump controls in the BFS are functionally identical to those for the PASS. They are located on the BFS MEMORY display, SPEC 0, items 21 - 24 (Figure 4-17).

The software dump procedure is similar to that of the PASS and is displayed in Figure 4-19. The only difference is that a BFS software memory dump is done in FXD format.

4.6.6.2 Hardware Memory Dump

Since hardware initiates a HISAM dump of a BFS GPC, it is identical to a HISAM dump of a PASS GPC, with two exceptions: there is no need to change the downlist GPC and it takes longer.

**DPS SSR-2
GPC S/W INITIATED MEM DUMP**

NOTE

Perform AOS. This procedure will generate a complete GPC Software Memory Dump in all in-flight OPS. Single item entry dumps must be performed in a HDR TFL

1. If vehicle configured with tape-driven MMU: ==MCC to ensure OPS RCDR 1(2) configured for dump

2. **SM 62 PCMMU/PL COMM**

If reqd, load dump TFL: LOAD PCMMU FORMAT (ORB OPS FS, COMM/INST)

3. If PASS:

- a. If GNC, SM, or PL9 Memory Dump:

On display assigned to GPC to be dumped,

GNC(SM,PL) 0 GPC MEMORY

If a specific GNC GPC to be dumped,

==DOWNLIST GPC - ITEM 44 +X EXEC

DUMP START/STOP - ITEM 43 EXEC

Item 40 (up), 41 (down) entries begin counting

Dump complete when ITEMS 40,41 blank

- b. If an OPS 0 GPC Memory Dump:

If target OPS 0 GPC MODE - HALT:

==Appropriate AV Bay Fan - ON

==Target GPC PWR - ON

Target GPC MODE - STBY (tb-RUN)

- RUN (OUTPUT tb-gray)

Assign desired IDP/CRT to OPS 0 GPC: GPC/CRT XX EXEC

PL 0 GPC MEMORY

DOWNLIST GPC - ITEM 44 +X EXEC

DUMP START/STOP - ITEM 43 EXEC

Item 40 (up), 41 (down) entries begin counting

Dump complete when ITEMS 40,41 blank

DOWNLIST GPC - ITEM 44 +X EXEC (lowest ID GNC GPC)

MF/OPS	GNC(OPS 0)	SM	PL9
DUMP TIME	2.2	5.7	MAX = 9.7

4. If BFS:

GNC 0 BFS MEMORY

DUMP START/STOP - ITEM 24 EXEC

Item 21 (up), 22 (down) entries begin counting

Dump complete when ITEMS 21,22 blank (after 8 min)

5. **SM 62 PCMMU/PL COMM**

If reqd, load post-dump TFL:

LOAD PCMMU FORMAT (ORB OPS FS, COMM/INST)

Figure 4-19. Malfunction procedures (S/W dump)

4.7 UPLINK

The BFS, like PASS, has the capability to accept and process uplink commands from the ground.

4.7.1 Uplink Command Flow

The BFS receives uplinks from the NSPs via either the Ku-band or the S-band system just as PASS does. In order to do this when not engaged, the BFS must be tracking the PASS on the string that has the currently selected NSP (string 1 for NSP 1 and string 3 for NSP 2). The BFS receives its uplink data directly by listening to responses from the FF MDM controlling the selected NSP. In the engaged state, the BFS controls the FCs and therefore receives uplink in the same manner as PASS.

4.7.2 Types of Uplink Commands

The BFS utilizes the same three types of commands as the PASS does. These include:

- Single-stage commands that are executed immediately upon receipt.
- Two-stage commands that are buffered and downlisted back to the ground for verification before the command is executed. A flashing "UL" is also displayed on any BFS CRTs while an uplink is in progress.
- SPCs, which are commands that are uplinked and stored to be executed at a later specific time. When the GPC's time matches the execute time in the command, the command is processed.

TMBUs are the usual kind of data uplinked to the BFS (via two-stage commands), since it performs the SM function during ascent and entry. The BFS does not support any RTCs from the ground or crew.

4.7.3 Uplink Control

All uplink control in BFS is done via the UPLINK switch on Panel C3. The three positions of the switch (NSP BLOCK, GPC BLOCK, and ENABLE) work the same for the BFS GPC as they do for the PASS GPCs.

There is no BFS software control of the uplink block function. BFS does not support any CRT display items relating to uplink control.

4.8 INITIALIZATION AND RECOVERY

4.8.1 BFS GPC IPL

Since the BFS GPC is nonredundant, any time the BFS GPC fails, another GPC is IPL'd as BFS and the failed GPC is made a PASS GPC. A BFS IPL requires the use of the menu option shown in Figure 4-20.

The first part of the IPL menu option is identical to the default option for PASS. Off-diagonal CAM lights are cleared, and the initial part of the IPL is done with the powered GPC in HALT and NORM. The difference is that a CRT is used to load the rest of the software. Before the GPC is taken to STBY a CRT is selected via the BFC CRT switches.

**DPS SSR-7
GPC IPL MENU OPTION (PASS/BFS)**

- NOTE
==MCC for reapplication of GMEMs as reqd
1. **SM 1 DPS UTILITY**
IPL SOURCE SW MASK – ITEM 38 EXEC (no *)
 - C2
C3 2. IDP/CRT 3(1,2) PWR – ON
BFC CRT DISP – ON
SEL – 3+1(1+2, 2+3) (Expect big 'X', POLL FAIL on MDU in DPS mode)
 - O6 3. IPL SOURCE – MMU 1(2)
GPC MODE 1(2,3,4,5) – HALT (tb-bp)
OUTPUT 1(2,3,4,5) – NORM (tb-bp)
 4. GPC PWR 1(2,3,4,5) – OFF,ON
 - F7 If BFS engaged:
FLT CNTLR PWR – ON
BFS ENGAGE pb – push
 - If off-diagonal CAM lts on, execute error log reset:
GNC 0 GPC MEMORY
ERR LOG RESET – ITEM 48 EXEC
Repeat for SM, PL, OPS 0 as applicable
 5. IPL 1(2,3,4,5) pb – push (tb-IPL, then bp within 2 min)
 - O6 6. When tb – bp or 2 min:
IDP LOAD 3(1,2) – LOAD
GPC MODE 1(2,3,4,5) – STBY (Tape-driven MMU: tb remains bp, expect CAM diagonal for 1 sec and Master Alarm) (Solid State MMU: tb remains bp, no CAM diagonal or Master Alarm expected)
 7. If GPC IPL MENU does NOT appear in 2 min:
GPC MODE 1(2,3,4,5) – HALT
If first attempt:
IPL SOURCE – MMU 2(1)
Go to step 4 and proceed (one time only)
 8. If **GPC IPL MENU** appears:
==ID of GPC is correct
Record MSGS STILL IN LIST _____
Record ERROR/MSG CODEs in space provided below, pressing MSG RESET
to cycle through list until MSGS STILL IN LIST = 0
Nominal Codes
1. ERROR/MSG CODE _____ ==132 (GPCIPL XX.XX.XX.XX LOADED)
2. ERROR/MSG CODE _____ ==137 (DCP XX.XX.XX.XX LOADED)
3. ERROR/MSG CODE _____
4. ERROR/MSG CODE _____
5. ERROR/MSG CODE _____
- NOTE
If ERROR/MSG CODEs 097 (no IDP poll response) and/or 112 (IDP BITE error) are received in addition to the two nominal codes, ignore and continue. For any other codes, STOP. ==MCC
9. If PASS IPL desired:
 - a. Load desired copy of PASS software from MM ITEM 1(3,5) EXEC (*) (MODE tb-RUN within 2 min) (Expect big 'X,' POLL FAIL on MDU in DPS mode)
 - O6
C2,R11 b. When tb – RUN or 2 min:
GPC MODE 1(2,3,4,5) – RUN
==OUTPUT 1(2,3,4,5) – NORM (tb-gray)
Desired IDP/CRT MAJ FUNC – PL
BFC CRT DISP – OFF
GPC/CRT IPL'd GPC/desired IDP EXEC
 - c. If **PL 0 GPC MEMORY** does NOT appear in 2 min:
GPC MODE 1(2,3,4,5) – HALT
If first attempt:
C3
O6 BFC CRT DISP – ON
IPL SOURCE – MMU 2(1)
Go to step 4 and proceed (one time only)
If second attempt:
GPC PWR 1(2,3,4,5) – OFF

Figure 4-20. Malfunction procedures (menu option)

DPS SSR-7 (Cont)

- d. IPL SOURCE – OFF
 - e. Go to step 11
10. If BFS IPL desired:
- a. If orbit config:
 - On MCC GO, select PCMMU format
 - OI PCMMU FORMAT – GPC
 - X: SM 62 PCMMU/PL COMM
 - PCMMU FMT SEL FXD – ITEM 1 EXEC (*)
- C3
- b. IPL SOURCE – OFF
 - c. Load desired copy of BFS software from MM:
 - ITEM 2(4) EXEC (*)
 - d. If 'BSL XX,XX,X,XX,XX LOADED' does not appear within 2 min:
 - GPC MODE 1(2,3,4,5) – HALT
 - If first attempt:
 - IPL SOURCE – MMU 2(1)
 - Go to step 4 and proceed (one time only)
 - e. If 'BSL XX,XX,X,XX,XX LOADED' appears (within 2 min),
 - MSG RESET pb – push (repeat until 'MSGs STILL IN LIST' = 0)
 - f. Expect 'KSC XX,XX,X,XX,XX LOADED'
 - If 'KSC X,XX,X,XX,XX LOADED,_SET MMU SEL SW TO OFF' appears, continue with procedure and notify MCC when convenient
 - MSG RESET pb – push (repeat until 'MSGs STILL IN LIST' = 0)
 - g. IDP/CRT MAJ FUNC – GNC
 - If GNC 0 BFS MEMORY does not appear within 2 min:
 - GPC MODE 1(2,3,4,5) – HALT
 - If first attempt:
 - IPL SOURCE – MMU 2(1)
 - Go to step 4 and proceed (one time only)
 - If second attempt:
 - GPC PWR 1(2,3,4,5) – OFF
 - h. If entry config:
 - BFS/GNC, OPS 301 PRO
 - i. If orbit config, verify BFS will track PASS strings:
 - When time permits, on MCC GO:
 - All RGAs – ON
 - cb ADTA (four) – cl
 - MLS (three) – ON
 - Primary RJD LOGIC, DRIVER (sixteen) – ON
 - All strings, CRTs, MMs, assigned to current GNC GPCs in MC3
 - PASS, GNC OPS 301 PRO
 - BFS, GNC, OPS 301 PRO
 - BFS, GNC, OPS 000 PRO
 - PASS, GNC, OPS 201 PRO
 - O14,O15
 - All RGAs – OFF
 - O16
 - cb ADTA (four) – op
 - O8
 - MLS (three) – OFF
 - Reconfig DAP and attitude per FLIGHT PLAN
 - O14,O15,O16
 - j. Select program PCMMU FORMAT:
 - OI PCMMU FORMAT – GPC
 - X: SM 62 PCMMU/PL COMM
 - PCMMU FMT PGM – ITEM 2 EXEC
 - Power off IDP/CRTs as reqd
 - C3
11. SM 1 DPS UTILITY
- IPL SOURCE SELECT SW MASK – ITEM 38 EXEC (*)

Figure 4-20. Malfunction procedures (menu option) (concluded)

In order to perform the IPL, the IDP must also be loaded (reloaded) from mass memory. This is done by the GPC being IPL'd when it is moded to STBY if the BFC CRT DISP switch is ON and the IDP LOAD discrete is set for the selected IDP. If the load is successful, the GPC IPL MENU display (Figure 4-21) appears.

```

BSL2 IPL MENU ( 1) 5 000/00: 01: 18
PASS1 1 PASS5 9 000/00: 00: 00
BFS1 2* BFS5 10 STP/PURGE CYC CNT 0
PASS2 3 PASS6 11 ERROR/MSG CODE 30
BFS2 4 BFS6 12 ERROR MSG CODE CNT 1
PASS3 5 PSS7 13 TOTAL ERR/MSG CNT 2
BFS3 6 BFS7 14 MSGS STILL IN LIST 1
PASS4 7 PASS8 15
BFS4 8 BFS8 16
MCDS BITE
MODE 0420
BSR1 8200
BSR2 8000
SWSW 0000
PCM BITE 0000

17 FORMAT LOAD

START GPC SELF TEST 18
START GPC SELF TEST 19
START DEU SELF TEST 20

START D/L OF TOGGLE BUFFER 1 21
START D/L OF TOGGLE BUFFER 5 22
STOP D/L 23
STOP STP ON ERROR 24
CONTINUE STP ON ERROR 25
INHIBIT CKPT LOAD 26

MEMORY PURGE
27 OPTION
START 28
STOP 29

ITEM 2 EXEC

```

5271. CRT: 1

Figure 4-21. IPL MENU display

The GPC IPL MENU provides the capability to do extended GPC self-test and PCMMU downlist control, but only items 1 and 2 and the error messages in the upper right corner are used during an IPL.

There are two nominal messages associated with an IPL and these are recorded in step 8. If any other error messages are in the list (except 097 and 112), the MCC should be consulted before continuing. If not, the BFS IPL is accomplished by executing item 2 in step 10. (Until this point, the PASS software could still have been loaded via item 1). First, a block of software called the Backup System Loader (BSL) is loaded in from the MMU with an accompanying message on the fault message line. The BSL software then controls the loading of the rest of the BFS software once the MSG RESET is pressed. The BFS is then running in OPS 0 and should command the CRT if the major function switch is in GNC or SM (CRT will be blank if in PL).

At this point, the ground has the crew take the PASS and BFS to GNC OPS 3 to ensure that the new BFS GPC can track the PASS. The desired configuration can then be selected. Recall that a software dump of a new BFS GPC is done to verify a good load.

4.8.2 IDP IPL

The procedure for loading an IDP using the BFS is exactly the same as when using a PASS GPC.

4.9 BFS ENGAGE

Since there is no redundancy in the BFS and the disengage process can be done only on orbit, the decision to engage the BFS is considered a last resort to save the vehicle. Since the crew only has a few seconds to decide this, the engage process was designed to be initiated by the push of a button.

There is an engage momentary pb on the left and right Rotational Hand Controllers (RHCs) (Figure 4-22). As long as the RHC is powered and the BFS GPC OUTPUT switch is in the BACKUP position, then depression of the engage pb is all that is necessary to engage the BFS and cause the PASS to relinquish control. This configuration is used during ascent and entry.

If more than one OUTPUT switch is in the BACKUP position, the GPC with the highest ID number is selected as the BFS GPC. If no GPC's OUTPUT switch is in the BACKUP position, BFS engage/PASS shutdown cannot occur. On orbit, the BFS GPC is moded to NORMAL to prevent an inadvertent engage.

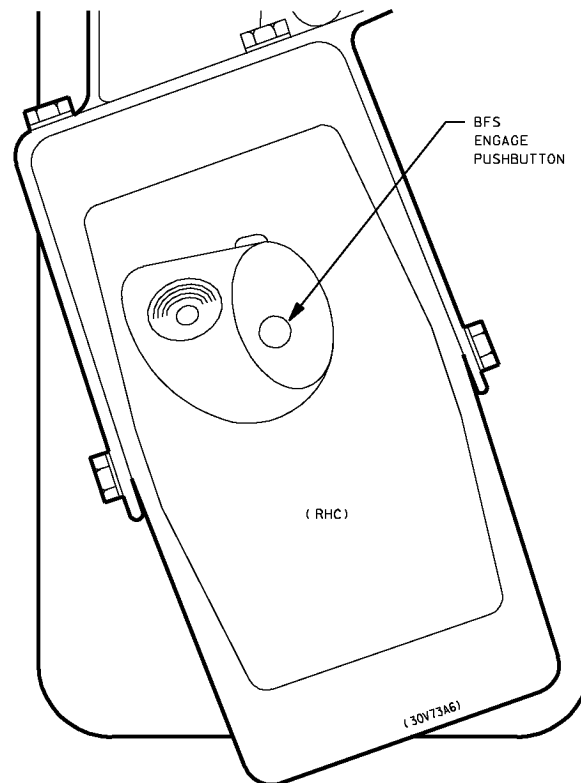

TD2920425. ART 1

Figure 4-22. Rotational hand controller

There are three contacts in each pb. All three contacts must be made in a given RHC for an engage to occur. Therefore, both the commander and the pilot press their engage pb's to protect against a contact failure. The signals from these contacts are sent to the BFC modules, which handle the engage logic (for example, checking for a

GPC in BACKUP) and send engage discrettes to the GPCs (which are “latched” on at the BFCs until disengage).

When a BFS engage occurs, the following indications are displayed:

- BFC eyebrow panel lights on Panels F2 (Figure 4-23) and F4 are ON.
- BFS OUTPUT tb on Panel O6 (Figure 4-24) is gray.
- All PASS GPC’s OUTPUT tb’s and MODE tb’s go to bp on Panel O6.
- BFS control of the second CRT as indicated by the BFC CRT SELECT switch (or control of CRTs 1 and 2 if the DISP switch is OFF) on Panel C3 (Figure 4-25).
- CRT “BIG X” and “POLL FAIL” are on the remaining CRTs.
- GPC status matrix has all four PASS GPCs diagonal I-fail lights ON on Panel O1 (Figure 4-26).

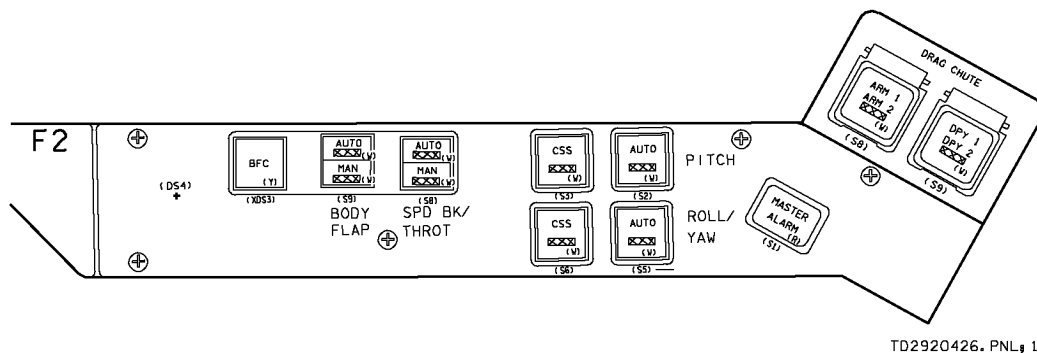

TD2920426. PNL# 1

Figure 4-23. Panel F2

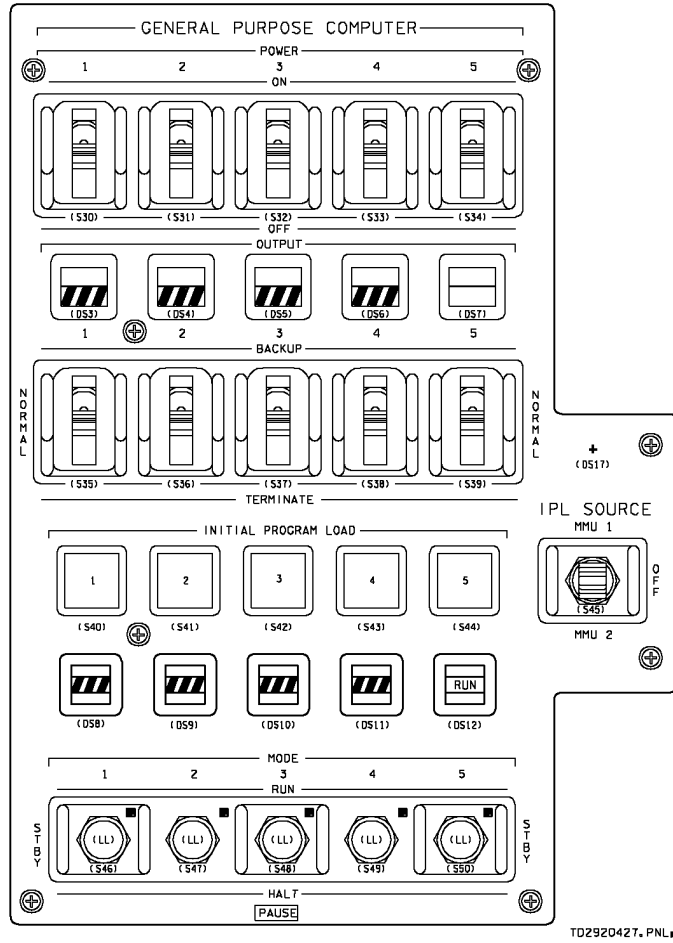

Figure 4-24. Panel O6

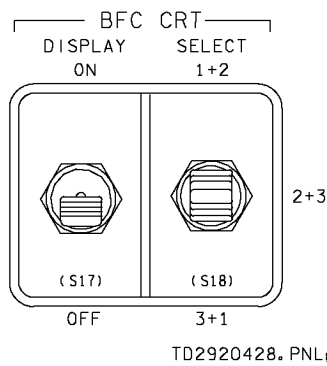
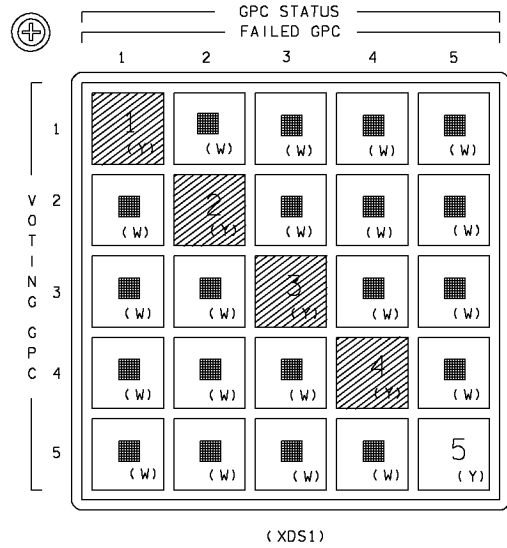

Figure 4-25. Panel C3



TD2924979.ART:1

Figure 4-26. Panel O1

If there are certain discrete inputs failed at any of the GPCs, it is possible for the BFS to engage and for one or more PASS GPCs to try to retain control of their strings. When this configuration is present, the BFS lights are on, the BFS OUTPUT tb is gray, and not all PASS GPCs OUTPUT tb's are bp. Garbage also appears on one or more CRTs due to dual IDP commanders. This situation can be corrected by taking those PASS GPCs to HALT and performing an I/O reset to the BFS.

When a BFS engage takes place, the PASS GPCs go to a state of software halt (if they receive all discrettes correctly). They must be IPL'd before they can be recovered. The BFS GPC immediately takes command of the FC and PL data buses. (If the BFS is in RUN at that time, it has already been commanding the PL data buses.) It also takes command of a second CRT, which is the crew's most obvious indication that an engage has been successful. At that point the crew probably assigns the third, uncommanded forward IDP to the BFS via the GPC/CRT key. The rest of the ascent or entry is then flown as normally as the limited BFS software allows.

4.10 BFS DISENGAGE

If the BFS is engaged during ascent, the PASS GPCs can be recovered on orbit to continue with a normal mission. This procedure, PASS RECOVERY AFTER BFS ENGAGE, takes about 2 hours because the PASS IMU reference must be reestablished. However, the actual disengage of BFS is quite simple. After all PASS GPCs have been hardware dumped and IPL'd, they are taken to GNC OPS 3 and the BFS is disengaged by moving the BFC DISENGAGE momentary switch on Panel F6 (Figure 4-27) to the right. The switch sends a signal to the BFCs, and they, in turn, reset the engage discrettes to the GPCs. If the BFS is in STBY, it then releases control of the payload data buses, as well as the FC data buses, and the PASS GPCs assume command.

Indications of a PASS recovery/BFS disengage are as follows:

- BFC light is flashing on Panels F2 and F4.
- BFS OUTPUT tb goes to barberpole on Panel O6.
- PASS OUTPUT tb's go to gray on Panel O6.
- BFS release/PASS control of second CRT.

After disengage, the PASS and BFS GPCs return to their normal, preengaged relationship. The procedure to recover the PASS IMU reference must then be performed since the PASS GPCs do not listen to the BFS and, therefore, do not have a current state vector or IMU attitude reference matrix. Further, the BFS GPC will need to be re-IPL'd sometime before entry, due to a design deficiency in BFS that leaves some software modules "attached" (i. e., active) that should not be when BFS is not engaged.

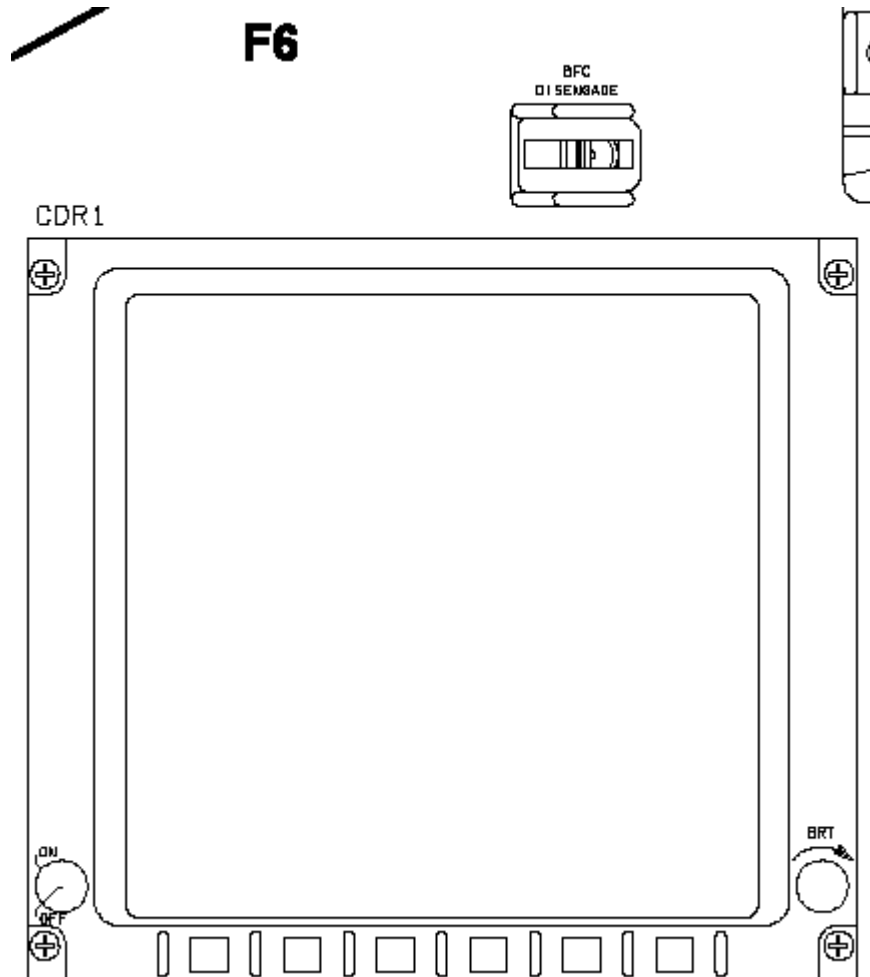

Figure 4-27. Panel F6

APPENDIX A ACRONYMS AND ABBREVIATIONS

A/D	Analog-to-Digital
ADC	Analog-to-Digital Converter
ADI	Attitude Direction Indicator
AMLCD	Active Matrix Liquid Crystal Display
AOA	Abort Once Around
AOS	Acquisition of Signal
APU	Auxiliary Power Unit
AUTO	Automatic
B/U	Backup
BCE	Bus Control Element
BFC	Backup Flight Controller
BFS	Backup Flight Software
BITE	Built-In Test Equipment
bp	barberpole
BSL	Backup System Loader
BSY	busy
BTU	Bus Terminal Unit
C&D	Controls and Displays
C&W, C/W	Caution and Warning
CAM	Computer Annunciation Matrix
cb	circuit breaker
CDR	Commander
CMD	Command
CMOS	Complementary Metal Oxide Semiconductor
COMM	Communications
COMMSEC	Communications Security
CONFIG	Configuration
CPLT	Complete
CPU	Central Processing Unit
CRT	Cathode-Ray Tube
CS	Common Set
CST	Comprehensive Self Test
D/L	Downlist
DDU	Display Driver Unit
DISP	Display
DK	Display/Keyboard
DPS	Data Processing System
ECC	Error Correcting Code
EDAC	Error Detection and Correction
EEPROM	Electrically Erasable Programmable Read-Only Memory
EIU	Engine Interface Unit

EMDM	Enhanced MDM
EMI	Electromagnetic Interference
ENA	Enable
ENG	Engine
ERR	Error
ESS	Essential
EXEC	Execute
FA	Flight Critical Aft
FAULT SUMM	Fault Summary
FC	Flight Critical
FDF	Flight Data File
FF	Flight Critical Forward
FM	Frequency Modulation
FMDM	Flex Multiplexer/Demultiplexer
FXD	Fixed
GMT	Greenwich Mean Time
GNC	Guidance, Navigation, and Control
GPC	General Purpose Computer
GSE	Government Supplied Equipment
H/W	Hardware
HDR	High Data Rate
HISAM	Hardware Initiated Stand-Alone Memory
HUD	Heads-Up Display
HYD	Hydraulic
I/F	Interface
I/O	Input/Output
ICC	Intercomputer Communication
ID	Identification
IDP	Integrated Display Processor
IFM	In-Flight Maintenance
IGN	Ignition
IMU	Inertial Measurement Unit
INH	Inhibit
IOM	Input/Output Module
IOP	Input/Output Processor
IP	Instrumentation/Pulse Code Modulation Master Unit
IPL	Initial Program Load
ISOL	Isolation
JSC	Johnson Space Center

kbs	kilobit per second
KBU	Keyboard Unit
KYBD	Keyboard
L	Left
LA	Launch Aft
LB	Launch Boost
LDB	Launch Data Bus
LDR	Low Data Rate
LF	Launch Forward
LL	Launch SRB Left
LM	Launch SRB Mid
LOS	Loss of Signal
LR	Launch SRB Right
LRU	Line Replaceable Unit
MAJ FUNC	Major Function
MALF	Malfunction
MC	Memory Configuration
MCC	Mission Control Center
MCDS	Multifunction CRT Display System
MCIU	Manipulator Controller Interface Unit
MDM	Multiplexer/Demultiplexer
MDU	Multifunction Display Unit
MEC	Master Events Controller
MECO	Main Engine Cutoff
MEDS	Multifunction Electronic Display System
MET	Mission Elapsed Time
MF	Major Function
MFB	Major Function Base
MFO	Major Function Overlay
MIA	Multiplexer Interface Adapter
MLS	Microwave Landing System
MM	Mass Memory
MMU	Modular Memory Unit
MPS	Main Propulsion System
MSG	Message
MSU	Mass Storage Unit
MTU	Master Timing Unit
NAV	Navigation
NBAT	Nominal Bus Assignment Table
NSP	Network Signal Processor
OI	Operational Instrumentation
OMS	Orbital Maneuvering System

OP	Open
OPS	Operational Sequence, Operations
OVRD	Override
PASS	Primary Avionics Software System
pb	pushbutton
PBI	Pushbutton Indicator
PCM	Pulse-Code Modulation
PCMMU	PCM Master Unit
PDI	Payload Data Interleaver
PF	Payload Forward (MDM)
PGM	Program, Programmable
PL	Payload
PLT	Pilot
PM	Pulse Modulation
PNL	Panel
PREVLV	Prevalve
PRI	Primary
PRO	Proceed
PROM	Programmable Read-Only Memory
PSP	Payload Signal Processor
PWR	Power
R	Read, Right
RA	Radar Altimeter
RAM	Random Access Memory
RCS	Reaction Control System
RCVR	Receiver
RDY	Ready
Reqd	Required
RHC	Rotational Hand Controller
RLF	Relief
RM	Redundancy Management
RMS	Remote Manipulator System
RPC	Remote Power Controller
RPTA	Rudder Pedal Transducer Assembly
RS	Redundant Set
RTC	Real-Time Command
RTLS	Return to Launch Site
S-BD	S-Band
S/W	Software
SBTC	Speedbrake/Thrust Controller
SCU	Sequence Control Unit
SE	Single-Engine
SEC	Second, Secondary
SEL	Select

SEP	Separation
SEQ	Sequence, Sequential
SF	Selection Filter
Shutdn	Shutdown
SM	Systems Management
SPC	Stored Program Command
SPEC	Specialist Function
SPI	Surface Position Indicator
SPL	Scratch Pad Line
SRB	Solid Rocket Booster
SSMM	Solid State Mass Memory
SSR	Solid State Recorder
STAT	Status
STBY	Standby
STDN	Spaceflight Tracking and Data Network
STKR	Star Tracker
STRG	String
SW	Switch
sync	synchronization, synchronize
SYS	System
SYS SUMM	Systems Summary
TACAN	Tactical Air Navigation
TAEM	Terminal Area Energy Management
TAL	Transoceanic Abort Landing
tb	talkback
TDRS	Tracking and Data Relay Satellite
TEMP	Temperature
TFL	Telemetry Format Load
THC	Translation Hand Controller
TIG	Time of Ignition
TLM	Telemetry
TMBU	Table Maintenance Block Update
TMP	Time Management Processor
TVC	Thrust Vector Control
VLV	Valve
WDS	Words
W/E	Write/Erase
XMTR	Transmitter
XPNDR	Transponder

APPENDIX B SUGGESTED REFERENCE DOCUMENTS

- a. Three other training manuals, Crew Software Interface (CSI 21002), DPS Overview (DPS OV 21002), and DPS Familiarization (DPS FAM 21002) should be read before this one.
- b. There are several other training manuals available that cover various aspects of GNC and SM.
- c. The procedures described in this book are specified in the following Flight Data File items:
 - Ascent Checklist
 - Ascent Pocket Checklist
 - Ascent/Entry Systems Procedures
 - Orbit OPS Checklist
 - Orbit Pocket Checklist
 - Entry Checklist
 - Entry Pocket Checklist
 - Systems Malfunction Procedures Book
 - Reference Data Book (also lists all PASS and BFS fault messages)
- d. Another element of the Flight Data File (although it is not flown and is available on the ground only) is the DPS Dictionary, which describes every item on every CRT display in PASS and BFS. It also lists the legal OPS/major mode transitions and the CRT displays available in each major mode.
- e. The Flight Rules book outlines preplanned decisions for failure situations. The DPS rules are in Sections 2 and 7.
- f. The Space Shuttle Systems Handbook has detailed drawings of all hardware components. Drawing 8.1 gives an excellent overview of how the various elements are connected to the GPCs.

Training Materials Evaluation

Please answer the following questions regarding the lesson you just completed. Your feedback will allow us to produce more effective training materials. When complete, mail to: **DPS/Navigation, DT35.**

TITLE/CODE OF LESSON: Data Processing System (Hardware and System Software) Workbook/DPS HW/SW 21002

SIZE OF AUDIENCES/CLASS:

1. How well did this lesson meet its purpose?

For each statement below, mark one box on the scale:

- | | Strongly Disagree | | | Strongly Agree | |
|--|--------------------------|--------------------------|--------------------------|--------------------------|--------------------------|
| a. <i>The lesson objectives are clearly stated.</i> | <input type="checkbox"/> | <input type="checkbox"/> | <input type="checkbox"/> | <input type="checkbox"/> | <input type="checkbox"/> |
| b. <i>The lesson objectives are clearly defined.</i> | <input type="checkbox"/> | <input type="checkbox"/> | <input type="checkbox"/> | <input type="checkbox"/> | <input type="checkbox"/> |
| c. <i>The lesson effectively teaches skills and information.</i> | <input type="checkbox"/> | <input type="checkbox"/> | <input type="checkbox"/> | <input type="checkbox"/> | <input type="checkbox"/> |
| d. <i>The lesson meets its purpose and objectives.</i> | <input type="checkbox"/> | <input type="checkbox"/> | <input type="checkbox"/> | <input type="checkbox"/> | <input type="checkbox"/> |

2. How satisfying is the content of this lesson?

For each statement below, mark one box on the scale:

- | | Strongly Disagree | | | Strongly Agree | |
|--|--------------------------|--------------------------|--------------------------|--------------------------|--------------------------|
| a. <i>The information is structured in a logical flow.</i> | <input type="checkbox"/> | <input type="checkbox"/> | <input type="checkbox"/> | <input type="checkbox"/> | <input type="checkbox"/> |
| b. <i>The content is clear.</i> | <input type="checkbox"/> | <input type="checkbox"/> | <input type="checkbox"/> | <input type="checkbox"/> | <input type="checkbox"/> |
| c. <i>The content is complete.</i> | <input type="checkbox"/> | <input type="checkbox"/> | <input type="checkbox"/> | <input type="checkbox"/> | <input type="checkbox"/> |
| d. <i>The level of detail is correct for this information.</i> | <input type="checkbox"/> | <input type="checkbox"/> | <input type="checkbox"/> | <input type="checkbox"/> | <input type="checkbox"/> |
| e. <i>The amount of information is effective.</i> | <input type="checkbox"/> | <input type="checkbox"/> | <input type="checkbox"/> | <input type="checkbox"/> | <input type="checkbox"/> |
| f. <i>The graphics contribute to my understanding.</i> | <input type="checkbox"/> | <input type="checkbox"/> | <input type="checkbox"/> | <input type="checkbox"/> | <input type="checkbox"/> |

3. How appealing was the presentation of this lesson?

For each statement below, mark one box on the scale:

- | | Strongly Disagree | | | Strongly Agree | |
|--|--------------------------|--------------------------|--------------------------|--------------------------|--------------------------|
| a. <i>The overall presentation is appealing.</i> | <input type="checkbox"/> | <input type="checkbox"/> | <input type="checkbox"/> | <input type="checkbox"/> | <input type="checkbox"/> |
| b. <i>The visuals chosen are appropriate for the lesson.</i> | <input type="checkbox"/> | <input type="checkbox"/> | <input type="checkbox"/> | <input type="checkbox"/> | <input type="checkbox"/> |
| c. <i>The visuals make the information more interesting.</i> | <input type="checkbox"/> | <input type="checkbox"/> | <input type="checkbox"/> | <input type="checkbox"/> | <input type="checkbox"/> |
| d. <i>The graphics are legibly reproduced.</i> | <input type="checkbox"/> | <input type="checkbox"/> | <input type="checkbox"/> | <input type="checkbox"/> | <input type="checkbox"/> |
| e. <i>The audio/visual or print quality is good.</i> | <input type="checkbox"/> | <input type="checkbox"/> | <input type="checkbox"/> | <input type="checkbox"/> | <input type="checkbox"/> |

4. How valuable is this information?

For each statement below, mark one box on the scale:

- | | Strongly Disagree | | | Strongly Agree | |
|---|--------------------------|--------------------------|--------------------------|--------------------------|--------------------------|
| a. <i>The lesson teaches skills and information I need.</i> | <input type="checkbox"/> | <input type="checkbox"/> | <input type="checkbox"/> | <input type="checkbox"/> | <input type="checkbox"/> |
| b. <i>The lesson meets my expectations.</i> | <input type="checkbox"/> | <input type="checkbox"/> | <input type="checkbox"/> | <input type="checkbox"/> | <input type="checkbox"/> |
| c. <i>This information is useful for later reference.</i> | <input type="checkbox"/> | <input type="checkbox"/> | <input type="checkbox"/> | <input type="checkbox"/> | <input type="checkbox"/> |
| d. <i>I would recommend this lesson to others.</i> | <input type="checkbox"/> | <input type="checkbox"/> | <input type="checkbox"/> | <input type="checkbox"/> | <input type="checkbox"/> |

**PLEASE WRITE YOUR COMMENTS/QUESTIONS ON THE BACK OF THIS FORM.
EXPLAIN ANY NEGATIVE ANSWERS IN SPECIFIC TERMS
THANK YOU IN ADVANCE FOR YOUR ASSISTANCE!**