

# EVA Checklist

## Mission Operations Directorate EVA, Robotics, and Crew Systems Operations Division

Generic, Rev H  
March 4, 2005

### NOTE

For STS-114 and subsequent (chronological) flights per current schedule.

National Aeronautics and  
Space Administration

Lyndon B. Johnson Space Center  
Houston, Texas

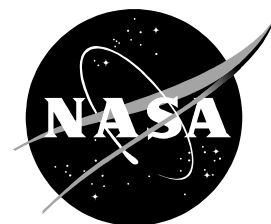



<b>EVA CHECKLIST</b>	<b>GENERIC, REV H (Mar 4, 2005)</b>
----------------------	-------------------------------------

**PCN-15 (Aug 28, 2008) Sheet 1 of 1**

List of Implemented Change Requests (482s):

EVA-1759                      MULTI-1823 **A**

<p><b>NOTE</b> For STS-125 and subsequent flights</p>
---

Incorporate the following:

1. Replace iii and iv
2. Replace 1-3 thru 1-10

Prepared by: *Sandra J. Fitch*  
Book Manager

Approved by: *Thomas Jones*  
Lead, EVA Systems Group

*[Signature]*  
Lead, EVA Task Group

Accepted by: *[Signature]*  
Chief, EVA Operations Branch

Encl: 10 pages

<b>File this PCN immediately behind the front cover as a permanent record</b>
---



<b>EVA CHECKLIST</b>	<b>GENERIC, REV H (Mar 4, 2005)</b>
----------------------	-------------------------------------

**PCN-14 (Apr 15, 2008) Sheet 1 of 1**

List of Implemented Change Requests (482s):

EVA-1758

Incorporate the following:

1. Replace iii and iv
2. Replace 4-11 and 4-12

<p><b>NOTE</b> For STS-124 and subsequent flights</p>
---

Prepared by: Pat S. Bohrer  
Book Manager

Approved by: Spencer K. Mack  
Lead, EVA Systems Group

Allyson Bohrer for Dina Contella  
Lead, EVA Task Group

Accepted by: [Signature]  
Chief, EVA and Crew Systems  
Operations Branch

Encl: 4 pages

<b>File this PCN immediately behind the front cover as a permanent record</b>
---



<b>EVA CHECKLIST</b>	<b>GENERIC, REV H (Mar 4, 2005)</b>
----------------------	-------------------------------------

**PCN-13 (Feb 15, 2008) Sheet 1 of 1**

List of Implemented Change Requests (482s):

EVA-1756  
EVA-1757

<p><b>NOTE</b> For STS-123 and subsequent flights</p>
---

Incorporate the following:

1. Replace iii and iv, vii and viii
2. Replace 14-7 and 14-8
3. Replace 15-11 and 15-12
4. Replace 19-1 and 19-2  
After 9-12, add 19-13 and 19-14

**Prepared by:**   
Book Manager

**Approved by:**   
Lead, EVA Systems Group

  
Lead, EVA Task Group

**Accepted by:**   
Chief, EVA and Crew Systems  
Operations Branch

Encl: 12 pages

<b>File this PCN immediately behind the front cover as a permanent record</b>
---





EVA CHECKLIST	GENERIC, REV H (Mar 4, 2005)
---------------	------------------------------

PCN-12 (Dec 14, 2007) Sheet 1 of 1

List of Implemented Change Requests (482s):

EVA-1755

Incorporate the following:

- 1. Replace iii and iv
- 2. Replace 4-1 and 4-2

**NOTE**  
For STS-123 and subsequent flights

Prepared by: Pal S. Dehn  
Book Manager

Approved by: Theresa Mack  
Lead, EVA Systems Group

[Signature]  
Lead, EVA Task Group

Accepted by: [Signature]  
Chief, EVA and Crew Systems  
Operations Branch

Encl: 4 pages

**File this PCN immediately behind the front cover as a permanent record**



EVA CHECKLIST

GENERIC, REV H (Mar 4, 2005)

## PCN-11 (Sept 28, 2007) Sheet 1 of 1

List of Implemented Change Requests (482s):

EVA-1754 MULTI-1806

**NOTE**

For STS-120 and subsequent flights

Incorporate the following:

1. Replace iii thru vi
2. Replace 3-3 and 3-4, 3-7 and 3-8
3. Replace 4-5 and 4-6, 4-9 and 4-10
4. Replace 10-1 and 10-2, 10-11 and 10-12  
After 10-12, add 10-13 and 10-14
5. Replace 12-7 and 12-8, 12-19 thru 12-22

Prepared by:

  
Book Manager

Approved by:

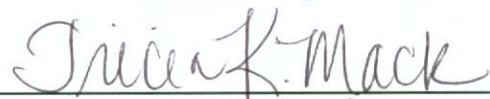
  
Lead, EVA Systems Group

  
Lead, EVA Task Group

Accepted by:

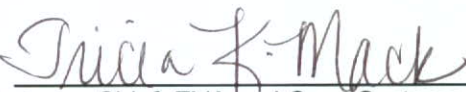
  
for Angela Prince, Chief, EVA and Crew Systems  
Operations Branch

Encl: 24 pages

**File this PCN immediately behind the front cover as a permanent record**



EVA CHECKLIST

GENERIC, REV H (Mar 4, 2005)

## PCN-10 (July 18, 2007) Sheet 1 of 1

List of Implemented Change Requests (482s):

EVA-1753

Incorporate the following:

1. Replace iii and iv
2. Replace 4-5 and 4-6, 4-9 and 4-10
3. Replace 12-7 and 12-8, 12-19 thru 12-22

**NOTE**

For STS-118 and subsequent flights

Prepared by:

  
Book Manager

Approved by:

  
Lead, EVA Systems Group  
Lead, EVA Task Group

Accepted by:

  
Chief, EVA and Crew Systems  
Operations Branch

Encl: 12 pages

**File this PCN immediately behind the front cover as a permanent record**



<b>EVA CHECKLIST</b>	<b>GENERIC, REV H (Mar 4, 2005)</b>
----------------------	-------------------------------------

**PCN-9 (June 15, 2007) Sheet 1 of 1**

List of Implemented Change Requests (482s):

EVA-1749                      MULTI-1787  
EVA-1750  
EVA-1751  
EVA-1752

<p><b>NOTE</b>  For STS-118 and subsequent flights</p>
--

Incorporate the following:

1. Replace iii thru vi
2. Replace 1-3 thru 1-10
3. Replace 4-5 and 4-6
4. Replace 8-1 and 8-2  
After 8-6, add 8-7 and 8-8
5. Replace 10-7 and 10-8

**Prepared by:**   
Book Manager

**Approved by:**  FOR TRICA MAER  
Lead, EVA Systems Group

 FOR Randy McDaniel  
Lead, EVA Task Group

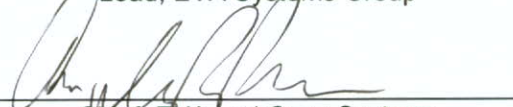
**Accepted by:**   
Chief, EVA and Crew Systems  
Operations Branch

Encl: 20 pages

<b>File this PCN immediately behind the front cover as a permanent record</b>
---





EVA CHECKLIST	GENERIC, REV H (Mar 4, 2005)
---------------	------------------------------

PCN-8 (May 22, 2007) Sheet 1 of 1

List of Implemented Change Requests (482s):

EVA-1747  
EVA-1748

<p align="center"><b>NOTE</b> For STS-117 and subsequent flights</p>
--

Incorporate the following:

1. Replace iii and iv
2. Replace 9-3 thru 9-6
3. Replace 10-7 thru 10-10

Prepared by:   
Book Manager

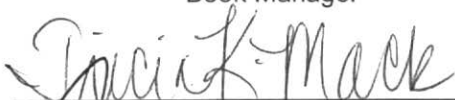
Approved by:   
Lead, EVA Systems Group

 for Randal McDaniel  
Lead, EVA Task Group

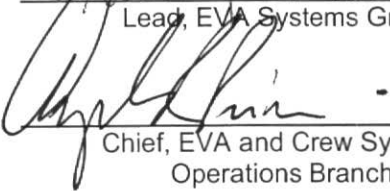
Accepted by:   
Chief, EVA and Crew Systems  
Operations Branch

Encl: 10 pages

File this PCN immediately behind the front cover as a permanent record
--



EVA CHECKLIST

GENERIC, REV H (Mar 4, 2005)

## PCN-7 (Feb 20, 2007) Sheet 1 of 1

List of Implemented Change Requests (482s):

EVA-1742                      EVA-1745  
EVA-1743                      EVA-1746  
EVA-1744

**NOTE**

For STS-117 and subsequent flights

Incorporate the following:

1. Replace iii thru vi
2. Replace 3-1 and 3-2, 3-7 thru CC 3-10
3. Replace 4-7 thru 4-10
4. Replace section 8 (6 pages)
5. Replace section 9 (6 pages)
6. Replace 10-1 and 10-2  
After 10-4, add 10-4a and 10-4b  
Replace 10-11 and 10-12

Prepared by:

  
Book Manager

Approved by:

  
Lead, EVA Systems Group

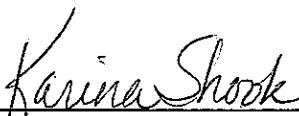
  
Lead, EVA Task Group  
for Randall McDaniel

Accepted by:

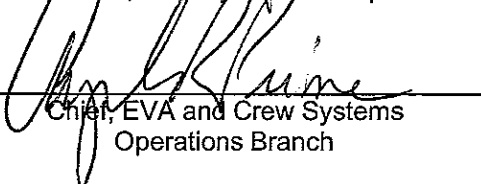
  
Chief, EVA and Crew Systems  
Operations Branch

Encl: 32 pages

**File this PCN immediately behind the front cover as a permanent record**



EVA CHECKLIST

GENERIC, REV H (Mar 4, 2005)

## PCN-6 (Nov 10, 2006) Sheet 1 of 1

List of Implemented Change Requests (482s):

EVA-1722  
EVA-1723  
EVA-1724  
EVA-1735  
EVA-1736

**NOTE**

For STS-116 and subsequent flights

Incorporate the following:

1. Replace iii and iv
2. Replace 3-3 thru 3-8
3. Replace 4-5 and 4-6
4. Replace 10-9 and 10-10
5. Replace 11-1 thru 11-4
6. Replace 15-9 and 15-10, 15-13 and 15-14

Prepared by:

  
Book Manager

Approved by:

  
Lead, EVA Systems Group

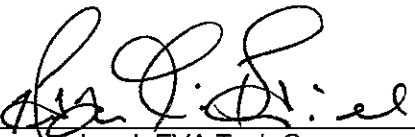
  
Lead, EVA Task Group

Accepted by:

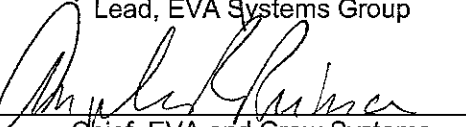
  
Chief, EVA and Crew Systems  
Operations Branch

Encl: 20 pages

**File this PCN immediately behind the front cover as a permanent record**



EVA CHECKLIST

GENERIC, REV H (Mar 4, 2005)

## PCN-5 (Aug 17, 2006) Sheet 1 of 1

List of Implemented Change Requests (482s):

EVA-1686                      EVA-1716  
EVA-1688  
EVA-1689  
EVA-1690

**NOTE**

For STS-115 and subsequent flights

Incorporate the following:

1. Replace iii and iv
2. Replace 1-3 thru 1-8
3. Replace 3-3 thru 3-8
4. Replace 4-5 thru 4-8
5. Replace 12-3 and 12-4
6. Replace 19-9 and 19-10

Prepared by:

*Paul S. Beck* 8-7-06  
Book Manager

Approved by:

*Trigian Mack* 8/7/06  
Lead, EVA Systems Group

*Steve Peltier* 8/8/06  
Lead, EVA Task Group

Accepted by:

*Myra Kuch* 8/8/06  
Chief, EVA and Crew Systems  
Operations Branch

Encl: 22 pages

**File this PCN immediately behind the front cover as a permanent record**





EVA CHECKLIST

GENERIC, REV H (Mar 4, 2005)

## PCN-4 (June 12, 2006) Sheet 1 of 1

List of Implemented Change Requests (482s):

EVA-1654  
EVA-1655  
EVA-1656  
EVA-1667  
EVA-1680

**NOTE**

For STS-121 and subsequent flights

Incorporate the following:

1. Replace iii thru viii
2. Replace 1-3 thru 1-8
3. Replace section 3 (12 pages)
4. Replace 4-1 thru 4-10  
After 4-10, add 4-11 and 4-12
5. Replace 5-1 and 5-2
6. Replace A6-1 and CC A6-2, B6-1 and CC B6-2
7. Replace 12-1 thru 12-4, 12-19 thru 12-22
8. Replace 14-3 thru 14-10, 14-13 and 14-14, 14-17 thru 14-22
9. Replace section 15 (14 pages)
10. Replace 19-9 and 19-10
11. Replace 20-1 and 20-2

Prepared by:

  
Book Manager

Approved by:

  
Lead, EVA Systems Group

  
Lead, EVA Task Group

Accepted by:

  
Chief, EVA and Crew Systems  
Operations Branch

Encl: 84 pages

**File this PCN immediately behind the front cover as a permanent record**



EVA CHECKLIST	GENERIC, REV H (Mar 4, 2005)
---------------	------------------------------

PCN-3 (Aug 1, 2005) Sheet 1 of 1

List of Implemented Change Requests (482s):

EVA-1633  
EVA-1652

<p align="center"><b>NOTE</b> For STS-121 and subsequent flights</p>
--

Incorporate the following:

1. Replace iii thru viii
2. Replace 15-1 thru 15-4

Prepared by: Paul S. Dachs  
Book Manager

Approved by: Jocelyn Mack  
Acting Lead, EVA Systems Group

Ken J. Fiel  
Lead, EVA Task Group

Accepted by: Charles P. ...  
Chief, EVA and Crew Systems  
Operations Branch

Encl: 10 pages

File this PCN immediately behind the front cover as a permanent record
--



EVA CHECKLIST

GENERIC, REV H (Mar 4, 2005)

## PCN-2 (June 10, 2005) Sheet 1 of 1

List of Implemented Change Requests (482s):

EVA-1608

Incorporate the following:

1. Replace iii and iv
2. Replace 12-15 and 12-16

**NOTE**

For STS-114 and subsequent flights

Prepared by:

Pat S. Baber  
Book Manager

Approved by:

Tricia K. Mack  
Acting Lead, EVA Systems Group

Scott A. Bleisath for Randy McDaniel  
Lead, EVA Task Group

Accepted by:

Angela R. Prince  
Chief, EVA and Crew Systems  
Operations Branch

Encl: 4 pages

**File this PCN immediately behind the front cover as a permanent record**



EVA CHECKLIST	GENERIC, REV H (Mar 4, 2005)
---------------	------------------------------

PCN-1 (Apr 8, 2005) Sheet 1 of 1

List of Implemented Change Requests (482s):

- EVA-1563                      EVA-1574                      MULTI-1694
- EVA-1566                      EVA-1575
- EVA-1570 (R)                EVA-1576
- EVA-1573

(R) Remainder of a previous partial implementation is in this publication

Incorporate the following:

1. Replace iii and iv
2. Replace 1-3 thru 1-10
3. Replace 2-1 and 2-2
4. Replace 4-5 thru 4-8
5. Replace 9-3 and 9-4
6. Replace 12-9 thru 12-14
7. Replace 15-3 and 15-4
8. Replace 19-5 and 19-6

Prepared by:   
 Book Manager

Approved by:   
 Lead, EVA Systems Group

  
 Lead, EVA Task Group

Accepted by:   
 Chief, EVA and Crew Systems  
 Operations Branch

Encl: 28 pages

**File this PCN immediately behind the front cover as a permanent record**





MISSION OPERATIONS DIRECTORATE

**EVA CHECKLIST**

GENERIC, REV H  
March 4, 2005

PREPARED BY:



Paul G. Boehm  
Book Manager

APPROVED BY:



Randall S. McDaniel  
Lead, EVA Task Group



Randall S. McDaniel  
Acting Lead, EVA Systems Group



Angela R. Prince  
Chief, EVA and Crew Systems Operations Branch

This document is under the configuration control of the Crew Procedures Control Board (CPCB). All proposed changes must be submitted on FDF Workflow Crew Procedure Change Request (CR) to DO3/FDF Manager.

Additional distribution of this book, for official use only, may be requested in writing to DO3/FDF Manager. The request must include justification and requester's name, organization, position, and phone number. Contractor requests are made through the NASA or DOD organization supported. Deletions, reduction in quantity, or change of address may be submitted to DO3/FDF Management Office, 281-244-1184.

Incorporates the following:				
482#:	EVA-1529	EVA-1555	EVA-1564	MULTI-1693
	EVA-1530	EVA-1556	EVA-1565	MULTI-1694
	EVA-1543	EVA-1557	EVA-1566	
	EVA-1544A	EVA-1558	EVA-1567	
	EVA-1546	EVA-1559	EVA-1568	
	EVA-1551	EVA-1560	EVA-1569	
	EVA-1552	EVA-1561	EVA-1570(P)	
	EVA-1553	EVA-1562		
	EVA-1554	EVA-1563		

(P) – Partially implemented in this publication

### AREAS OF TECHNICAL RESPONSIBILITY

Book Manager	DX35/P. Boehm	281-483-5447
Task Procedures	DX32/K. Shook	281-483-4474

EVA CHECKLIST

**LIST OF EFFECTIVE PAGES**

GENERIC	12/07/87	PCN-5	08/17/06	PCN-11	09/28/07
REV H	03/04/05	PCN-6	11/10/06	PCN-12	12/14/07
PCN-1	04/08/05	PCN-7	02/20/07	PCN-13	02/15/08
PCN-2	06/10/05	PCN-8	05/22/07	PCN-14	04/15/08
PCN-3	08/01/05	PCN-9	06/15/07	PCN-15	08/28/08
PCN-4	06/12/06	PCN-10	07/18/07		

Sign Off .....	*	ALL/GEN H	4-11 .....	ALL/GEN H,14
ii.....	*	ALL/GEN H	4-12 .....	ALL/GEN H,4
iii.....	*	ALL/GEN H,15	5-1 .....	ALL/GEN H
iv.....	*	ALL/GEN H,13	5-2 .....	ALL/GEN H,4
v .....		ALL/GEN H,4	5-3 .....	ALL/GEN H
vi.....		ALL/GEN H,11	5-4 .....	ALL/GEN H
vii.....		ALL/GEN H,4	A6-1.....	NOM/GEN H
viii.....		ALL/GEN H,13	CC A6-2.....	NOM/GEN H,4
1-1 .....		ALL/GEN H	B6-1.....	TNL/GEN H
1-2.....		ALL/GEN H	CC B6-2.....	TNL/GEN H,4
1-3.....		ALL/GEN H,15	6-3 .....	ALL/GEN H
1-4.....		ALL/GEN H	CC 6-4 .....	ALL/GEN H
1-5.....		ALL/GEN H	7-1 .....	ALL/GEN H
1-6.....		ALL/GEN H,15	7-2 .....	ALL/GEN H
1-7.....		ALL/GEN H	8-1 .....	ALL/GEN H,9
1-8.....		ALL/GEN H,15	8-2 .....	ALL/GEN H,9
1-9.....		ALL/GEN H,15	8-3 .....	ALL/GEN H
1-10.....		ALL/GEN H	8-4 .....	ALL/GEN H,7
2-1 .....		ALL/GEN H,1	8-5 .....	ALL/GEN H,7
2-2.....		ALL/GEN H,1	8-6 .....	ALL/GEN H
2-3.....		ALL/GEN H	8-7 .....	ALL/GEN H,9
2-4.....		ALL/GEN H	8-8 .....	ALL/GEN H,9
2-5.....		ALL/GEN H	9-1 .....	ALL/GEN H
2-6.....		ALL/GEN H	9-2 .....	ALL/GEN H,7
3-1 .....		ALL/GEN H,4	9-3 .....	ALL/GEN H,7
3-2.....		ALL/GEN H,7	9-4 .....	ALL/GEN H,8
3-3.....		ALL/GEN H,11	9-5 .....	ALL/GEN H,8
3-4.....		ALL/GEN H,6	9-6 .....	ALL/GEN H
3-5.....		ALL/GEN H,6	10-1 .....	ALL/GEN H,11
3-6.....		ALL/GEN H,6	10-2 .....	ALL/GEN H
3-7.....		ALL/GEN H,11	10-3 .....	ALL/GEN H
3-8.....		ALL/GEN H,7	10-4 .....	ALL/GEN H
3-9.....		ALL/GEN H,7	10-4a .....	ALL/GEN H,7
CC 3-10.....		ALL/GEN H,4	10-4b .....	ALL/GEN H,7
CC 3-11.....		ALL/GEN H,4	10-5 .....	ALL/GEN H
3-12.....		ALL/GEN H,4	10-6 .....	ALL/GEN H
4-1 .....		ALL/GEN H,4	10-7 .....	ALL/GEN H
4-2.....		ALL/GEN H,12	10-8 .....	ALL/GEN H,9
4-3.....		ALL/GEN H,4	10-9 .....	ALL/GEN H,8
4-4.....		ALL/GEN H	10-10 .....	ALL/GEN H
4-5.....		ALL/GEN H,11	10-11 .....	ALL/GEN H,7
4-6.....		ALL/GEN H,4	10-12 .....	ALL/GEN H,11
4-7.....		ALL/GEN H,5	10-13 .....	ALL/GEN H,11
4-8.....		ALL/GEN H,7	10-14 .....	ALL/GEN H,11
4-9.....		ALL/GEN H,7	11-1 .....	ALL/GEN H
4-10.....		ALL/GEN H,11	11-2 .....	ALL/GEN H,6

\* – Omit from flight book

Δ – Replace with page from Flight Supplement, if applicable. Otherwise, not flown

11-3.....	ALL/GEN H,6	14-16.....	ALL/GEN H
11-4.....	ALL/GEN H	14-17.....	ALL/GEN H
12-i.....	ALL/GEN H	14-18.....	ALL/GEN H,4
12-ii.....	ALL/GEN H	14-19.....	ALL/GEN H
12-1.....	ALL/GEN H	14-20.....	ALL/GEN H,4
12-2.....	ALL/GEN H,4	14-21.....	ALL/GEN H
12-3.....	ALL/GEN H	14-22.....	ALL/GEN H,4
12-4.....	ALL/GEN H,5	15-1.....	ALL/GEN H,4
12-5.....	ALL/GEN H	15-2.....	ALL/GEN H,4
12-6.....	ALL/GEN H	15-3.....	ALL/GEN H,4
12-7.....	ALL/GEN H,11	15-4.....	ALL/GEN H,4
12-8.....	ALL/GEN H	15-5.....	ALL/GEN H,4
12-9.....	ALL/GEN H	15-6.....	ALL/GEN H,4
12-10.....	ALL/GEN H,1	15-7.....	ALL/GEN H,4
12-11.....	ALL/GEN H,1	15-8.....	ALL/GEN H,4
12-12.....	ALL/GEN H,1	15-9.....	ALL/GEN H,6
12-13.....	ALL/GEN H	15-10.....	ALL/GEN H,4
12-14.....	ALL/GEN H,1	15-11.....	ALL/GEN H,4
12-15.....	ALL/GEN H,2	15-12.....	ALL/GEN H,13
12-16.....	ALL/GEN H,2	15-13.....	ALL/GEN H,6
12-17.....	ALL/GEN H	15-14.....	ALL/GEN H,4
12-18.....	ALL/GEN H	16-i.....	ALL/GEN H
12-19.....	ALL/GEN H,11	16-ii.....	ALL/GEN H
12-20.....	ALL/GEN H,4	16-1.....	ALL/GEN H
12-21.....	ALL/GEN H	16-2.....	ALL/GEN H
12-22.....	ALL/GEN H,11	17-1.....	Δ ALL/GEN H
12-23.....	ALL/GEN H	17-2.....	Δ ALL/GEN H
12-24.....	ALL/GEN H	18-1.....	Δ ALL/GEN H
12-25.....	ALL/GEN H	18-2.....	Δ ALL/GEN H
12-26.....	ALL/GEN H	19-i.....	ALL/GEN H
13-1.....	Δ ALL/GEN H	19-ii.....	ALL/GEN H
13-2.....	Δ ALL/GEN H	19-1.....	ALL/GEN H,13
14-1.....	ALL/GEN H	19-2.....	ALL/GEN H
14-2.....	ALL/GEN H	19-3.....	ALL/GEN H
14-3.....	ALL/GEN H	19-4.....	ALL/GEN H
14-4.....	ALL/GEN H,4	19-5.....	ALL/GEN H
14-5.....	ALL/GEN H	19-6.....	ALL/GEN H,1
14-6.....	ALL/GEN H,4	19-7.....	ALL/GEN H
14-7.....	ALL/GEN H,13	19-8.....	ALL/GEN H
14-8.....	ALL/GEN H	19-9.....	ALL/GEN H
14-9.....	ALL/GEN H	19-10.....	ALL/GEN H,5
14-10.....	ALL/GEN H,4	19-11.....	ALL/GEN H
14-11.....	ALL/GEN H	19-12.....	ALL/GEN H
14-12.....	ALL/GEN H	19-13.....	ALL/GEN H,13
14-13.....	ALL/GEN H	19-14.....	ALL/GEN H,13
14-14.....	ALL/GEN H,4	20-1.....	* ALL/GEN H
14-15.....	ALL/GEN H	20-2.....	* ALL/GEN H,4

#### EVA CUE CARDS

<u>Title</u>	<u>Ref. Page</u>	<u>Card No.</u>
SAFER CHECKOUT RESULTS (Front).....	CC 3-10	EVA-3a/O/C
SAFER STATUS TROUBLESHOOTING (Back) .....	CC 3-11	EVA-3b/O/D
DEPRESS/REPRESS		
(Nominal Configuration) (Front).....	CC A6-2	EVA-1a/NOM/O/J
(Tunnel Adapter Configuration) (Front) .....	CC B6-2	EVA-2a/TNL/O/V
FAILED LEAK CHECK		
(Back of DEPRESS/REPRESS).....	CC 6-4	EVA-1b/O/J EVA-2b/O/J

Δ – Replace with pages from Flight Supplement, if applicable. Otherwise, not flown

\* – Omit from flight book

CONTENTS

PAGE

10.2 PSI CABIN .....	1-1
MASK PREBREATHE INITIATE .....	1-2
PREP FOR 10.2 PSI CABIN .....	1-3
CABIN DEPRESS TO 10.2 PSI.....	1-4
10.2 PSIA DEPRESS CHART .....	1-5
10.2 PSI CABIN CONFIG .....	1-6
MASK PREBREATHE TERMINATE .....	1-6
10.2 PSI MAINTENANCE.....	1-7
CABIN REPRESS TO 14.7 PSI.....	1-8
14.7 PSI CABIN CONFIG.....	1-9
AIRLOCK CONFIG.....	2-1
AIRLOCK PREP .....	2-2
EMU SWAP .....	2-3
BOOSTER FAN DEACTIVATION/REMOVAL.....	2-4
BOOSTER FAN INSTALLATION/ACTIVATION.....	2-4
EMU REMOVAL .....	2-4
EMU INSTALLATION .....	2-4
EMU CHECKOUT PREP.....	2-5
LTA RESTRAINT STRAP REMOVAL .....	2-6
LTA RESTRAINT STRAP INSTALLATION .....	2-6
CHECKOUTS.....	3-1
EMU CHECKOUT .....	3-2
EMU POWERUP AND COMM CHECK.....	3-2
PRIMARY REGULATOR/FAN/PUMP CHECK .....	3-4
SOP CHECK.....	3-5
BATTERY CHARGE CHECK INIT.....	3-6
BATTERY CHARGE CHECK TERM .....	3-6
EMU SWAP DURING CHECKOUT .....	3-7
POST EMU C/O RECONFIG .....	3-7
SAFER CHECKOUT .....	3-8
SELF TEST SEQUENCE .....	3-9
SAFER CHECKOUT RESULTS.....	CC 3-10
SAFER STATUS TROUBLESHOOTING .....	CC 3-11
REBA POWERED HARDWARE CHECKOUT .....	3-12
EVA PREP .....	4-1
MIDDECK PREP .....	4-2
EVA PREP.....	4-3
PREP FOR DONNING.....	4-3
EMU DONNING .....	4-5
EMU CHECK .....	4-7
EMU PURGE.....	4-7
EMU PREBREATHE .....	4-8
SAFER DONNING .....	4-8
EVA COMM CONFIG .....	4-10
EVA COMM DECONFIG .....	4-10
APPROVED NON-EMU HARDWARE MATRIX.....	4-11
EMU STATUS .....	5-1
EMU STATUS .....	5-2

DEPRESS/REPRESS .....	6-1
DEPRESS/REPRESS (NOM A/L) .....	CC A6-2
DEPRESS/REPRESS (TNL) .....	CC B6-2
FAILED LEAK CHECK .....	6-3
FAILED LEAK CHECK (5 PSI) .....	CC 6-4
FAILED LEAK CHECK (14.7/10.2 PSI) .....	CC 6-4
FLIGHT SPECIFIC TIMELINES .....	7-1
TOOLS AND STOWAGE .....	8-1
PORT LIGHTWEIGHT TOOL STOWAGE ASSEMBLY (TSA) .....	8-2
PGT CHECKOUT .....	8-3
PGSC-PGT CONNECTION (A31P AND 760XD) .....	8-4
PROGRAM PGT SETTINGS .....	8-5
DOWNLOAD/ERASE EVENT LOG .....	8-5
PGT CONTINGENCIES .....	8-6
PGT STANDARD SETTINGS .....	8-7
POST EVA .....	9-1
POST EVA .....	9-2
SUIT DOFFING .....	9-2
SAFER DOFFING .....	9-2
EMU WATER RECHARGE .....	9-3
SAFER STOW .....	9-3
SUIT DRYING/SEAL WIPE .....	9-4
OXYGEN RECHARGE VERIFICATION .....	9-4
WATER FILL VERIFICATION .....	9-4
EMU POWERDOWN/OVERNIGHT STOW .....	9-5
EMU MAINT/RECHARGE .....	10-1
WATER RECHARGE .....	10-2
EMU POWERUP .....	10-2
WATER FILL .....	10-2
WATER FILL VERIFICATION .....	10-2
EMU LiOH CHANGEOUT .....	10-4
MIDDECK EMU BATTERY RECHARGE (STAND-ALONE) .....	10-4a
MIDDECK EMU BATTERY RECHARGE/LiOH REPLACEMENT .....	10-5
INITIATE .....	10-5
TERMINATE .....	10-6
IN-SUIT EMU BATTERY RECHARGE/CHARGE VERIFICATION .....	10-7
INITIATE .....	10-7
TERMINATE .....	10-7
EMU POWERDOWN .....	10-7
HELMET LIGHT/PGT BATTERY RECHARGE .....	10-8
INITIATE .....	10-8
TERMINATE .....	10-9
REBA BATTERY INSTALLATION .....	10-9
EMU BATTERY REMOVAL/INSTALL .....	10-10
HELMET LIGHT BULB CHANGEOUT .....	10-11
REBA BATTERY RECHARGE .....	10-12
INITIATE .....	10-12
TERMINATE .....	10-13
POST EVA ENTRY PREP .....	11-1
POST EVA ENTRY PREP .....	11-2
SAFER ENTRY STOW .....	11-2
POST ISS EVA ENTRY PREP .....	11-3
SAFER ENTRY STOW .....	11-3

<u>OFF-NOMINAL PROCEDURES</u> .....	12-i
EMU CONTINGENCY PROCS .....	12-1
DISPLAY LOSS DURING POWER TRANSFER (WARM RESTART) .....	12-2
VACUUM H2O RECHARGE (MANNED) .....	12-2
LIOH REPLACEMENT (MANNED) .....	12-3
BATTERY REPLACEMENT (MANNED) .....	12-4
WATER DUMP .....	12-6
SCU SWAP (UNMANNED) .....	12-7
SCU SWAP (MANNED) .....	12-7
EMU COLD RESTART (MANNED) .....	12-7
12.1 STS EVA DECONTAMINATION .....	12-8
CONTAMINATION TEST .....	12-15
SAFER BATTERY CHANGEOUT .....	12-18
BENDS TREATMENT ADAPTER (BTA) INSTALLATION (IN-SUIT) .....	12-19
BTA PREP .....	12-19
BTA TREATMENT .....	12-19
BENDS TREATMENT ADAPTER (BTA) INSTALLATION (PHASE 2 DOFFING) .....	12-21
BTA PREP .....	12-21
BTA TREATMENT .....	12-21
EMU RESIZE .....	12-24
 TPS REPAIR .....	 13-1
 ORBITER CONTINGENCY EVA .....	 14-1
PAYLOAD BAY EVA NOMENCLATURE .....	14-2
RMS/PRLA CONTINGENCY EVA .....	14-3
96 BOLT PRE-EVA TOOL CONFIG .....	14-13
96 BOLT EVA TIMELINE .....	14-14
CAPTURE LATCH MANUAL RELEASE (ODS/PMA) .....	14-19
96 BOLT EVA LAYOUT .....	14-21
PLBD LATCH TOOL PLACEMENT WITH DUAL LATCH GANG FAILURES .....	14-22
 EVA CUFF CHECKLIST (CIL) .....	 15-1
NORMAL EVA STATUS .....	15-2
DCM CONFIGURATION .....	15-2
EMU MALFUNCTION INDEX .....	15-2
DECOMPRESSION SICKNESS (DCS) .....	15-3
DECOMPRESSION SICKNESS (DCS) (CONT) .....	15-3
ABORT EVA .....	15-3
TERMINATE EVA .....	15-3
SUIT P EMERG .....	15-4
SOP O2 ON .....	15-4
BATT AMPS HIGH .....	15-4
BATT V DECAY OR BATT VDC LOW .....	15-4
SUIT P LOW .....	15-5
SUIT P HIGH .....	15-5
SOP P LOW .....	15-5
O2 USE HIGH .....	15-5
SUBLM PRESS .....	15-6
H2O GP LOW .....	15-6
RESRV H2O ON .....	15-6
H2O WP HIGH .....	15-6
NO VENT FLOW .....	15-7
CO2 HIGH OR MONITOR CO2 .....	15-7
CO2 SNSR BAD .....	15-7

COMM FAILURE .....	15-7
AIR FLOW CONTAMINATION .....	15-8
LOSS OF COOLING .....	15-8
RLF V FAIL .....	15-8
MISC MSGS 1 .....	15-8
MISC MSGS (CONT)/TIME LF .....	15-9
AIRLOCK LATCH DISCONNECT .....	15-9
AIRLOCK INGRESS.....	15-9
 <u>FOLLOWING PAGES NOT IN EV CUFF</u>	
RADIATOR ACTUATOR DISCONNECT .....	15-9
PLBD DRIVE CUT .....	15-10
DOOR DRIVE RESTRAINT .....	15-10
DOOR DRIVE DISCONNECT .....	15-10
WINCH OPERATIONS.....	15-10
WINCH OPERATIONS (CONT) .....	15-11
3-PT TOOL INSTALLATION .....	15-11
CL LATCH TOOL .....	15-11
RMS JOINT ALIGN .....	15-11
MPM STOW/DEPLOY .....	15-12
RMS TIEDOWN.....	15-12
RMS FLIGHT RELEASABLE GRAPPLE FIXTURE RELEASE .....	15-12
PRLA OPEN/CLOSE .....	15-12
PRLA OPEN/CLOSE (CONT) .....	15-13
KU ANTENNA STOW.....	15-13
KU ANTENNA STOW (CONT) .....	15-13
AIRLOCK EGRESS.....	15-13
 <u>FLIGHT SPECIFIC REFERENCE</u> .....	
UNSCHEDULED/CONTINGENCY EVA TASKS .....	16-1
EVA REFERENCE.....	17-1
FLIGHT SPECIFIC.....	18-1
 <u>EVA EMERGENCY</u> .....	
EMERGENCY PROCEDURES.....	19-1
EMERGENCY AIRLOCK REPRESS .....	19-3
EMERGENCY AIRLOCK REPRESS.....	19-4
POST EMERGENCY AIRLOCK REPRESS .....	19-4
SAFER RESCUE.....	19-5
SAFER RESCUE .....	19-6
DAP/EVA RESCUE/RETRIEVE .....	19-7
EVA ORBITER CONFIG.....	19-7
EVA RESCUE/RETRIEVE.....	19-9
19.1 DCS TREATMENT .....	19-10
CONTINGENCY SHUTTLE AIRLOCK INGRESS FROM ISS .....	19-13
CUE CARD CONFIGURATION .....	20-1



10.2 PSI CABIN

MASK PREBREATHE INITIATE.....	1-2
PREP FOR 10.2 PSI CABIN.....	1-3
CABIN DEPRESS TO 10.2 PSI.....	1-4
10.2 PSIA DEPRESS CHART .....	1-5
PSI CABIN CONFIG .....	1-6
MASK PREBREATHE TERMINATE.....	1-6
10.2 PSI MAINTENANCE .....	1-7
CABIN REPRESS TO 14.7 PSI.....	1-8
14.7 PSI CABIN CONFIG .....	1-9

**MASK PREBREATHE INITIATE**

1. Take one aspirin tablet (325 mg) if not taken previously
2. Configure quick don mask, HIU, and 14 ft comm/O2 umbilicals (two)
- C7  
L2 3. √LEH O2 SPLY 1,2 vlv (two) – OP
4. O2 XOVR SYS 2 – CL
- C6,  
MO32M,  
MO69M 5. LEH O2 4(5,6,7) outlet – connect O2 hose
- MO39M 6. MIDDECK COMM CCU PWR – OFF  
outlet – connect comm cable  
CCU PWR – ON
7. Decrease HIU volume control
- C6,  
MO32M,  
MO69M 8. LEH O2 4(5,6,7) vlv – OP

**WARNING**

Positive mask O2 pressure and fit are necessary to ensure adequate prebreathe

9. Verify black plates in top of mask are seated in silicon
10. Don mask
11. Set mask O2 control to EMERGENCY
12. Momentarily pull mask away from face and verify O2 flow  
\* If no positive O2 flow, contact MCC \*
13. √Comm
14. Configure ATU for PTT/PTT as reqd to alleviate comm noise

**WARNING**

Do not terminate prebreathe until cabin pressure at 10.2 psia and 1 hr prebreathe completed

15. Note time and continue mask prebreathe at least 1 hr

## PREP FOR 10.2 PSI CABIN

### PRESS/CRYO SYS CONFIG

- L2
- √O2 SYS 1,2 SPLY (two) – ctr (tb-OP)  
     √XOVR SYS 1 – OP  
         2 – CL
  - √N2 SYS 1,2 SPLY (two) – ctr (tb-OP)  
     √REG INLET (two) – ctr (tb-OP)
  - O2/N2 CNTLR VLV SYS 1 – OP (N2)  
     2 – CL (O2)
- SM 88 APU/ENVIRON THERM**
- L1
- If FLASH EVAP CNTLR PRI A,B – OFF:  
     If FREON LOOP 1,2 EVAP OUT T between  
     41-47 degF:  
         RAD CNTLR OUT TEMP – HI  
         When FREON EVAP OUT TEMP > 50 degF,  
         RAD CNTLR OUT TEMP – NORM (then  
         immediately)  
         FLASH EVAP CNTLR PRI A(B) – ON  
         After ~1 min  
         √FREON EVAP OUT TEMP ~39 degF  
     If FREON LOOP 1,2 EVAP OUT T not between  
     41-47 degF:  
         FLASH EVAP CNTLR PRI A(B) – ON
- L1
- If FLASH EVAP CNTLR PRI A(B) – ON, continue:

### AIRLOCK/MIDDECK PREP

- MO10W
- O2 REG INLET SYS 1 vlv – CL  
     2 vlv – OP
- AW18A
- √N2 XOVR vlv – CL
- DCM
- LTG FLOOD (four) – ON
  - √PURGE vlv – op (up)
- AW82B
- Remove LTA Restraint Bag (1 ea EMU)
  - AIRLK DEPRESS vlv cap – vent, remove

### RESET FDA & C/W LIMITS

**X: SM 60 SM TABLE MAINT**

- Contact MCC for uplink of B/U C/W and SM ALERT  
     TMBU (if desired)  
     Changes enclosed in

PARAMETER NAME	C/W CHL	H/W C/W		H/W & B/U ENA/INH	PARA ID	B/U C/W	
		LO V	HI V			LO EU	HI EU
CABIN PRESS (OV103)	4	2.50	3.85	ENA	0612405	10.0	15.2
(OV104)	4	2.50	3.85	ENA	0612405	10.0	15.2
(OV105)	4	2.45	3.80	ENA	0612405	10.0	15.2
O2 FLOW (OV103,5)							
1	14		4.90	INH	0612105		4.9
2	24		4.90	INH	0612205		4.9
PPO2 A	34	2.55	3.60	ENA	0612511	2.55	3.6
B	44	2.55	3.60	ENA	0612513	2.55	3.6
N2 FLOW (OV103,5)							
1	54		4.90	INH	0612553		4.9
2	64		4.90	INH	0612554		4.9
FAN ΔP	74	1.75	4.25	ENA	0612556	2.8	6.8

PARAMETER NAME	ENA/INH	PARA ID	SM ALERT	
			LOW	HIGH
OV-103				
AV BAY 1 FAN ΔP	ENA	0612642	2.40	4.80
AV BAY 2 FAN ΔP	ENA	0612647	1.90	4.60
AV BAY 3 FAN ΔP	ENA	0612658	2.50	4.90
OV-104				
AV BAY 1 FAN ΔP	ENA	0612642	1.90	4.90
AV BAY 2 FAN ΔP	ENA	0612647	1.90	4.80
AV BAY 3 FAN ΔP	ENA	0612658	2.40	5.00
OV-105				
AV BAY 1 FAN ΔP	ENA	0612642	2.40	4.80
AV BAY 2 FAN ΔP	ENA	0612647	1.90	4.60
AV BAY 3 FAN ΔP	ENA	0612658	2.50	5.00
IMU FAN ΔP	ENA	0612869	2.7	4.95
CABIN O2 CONCENTRATION	ENA	0922104		28.5
AIRLK P	INH	0640101	13.8	15.7
EXT AIRLK P	INH	0640126	13.8	15.7

## CABIN DEPRESS TO 10.2 PSI

### WARNING

Do not initiate depress until EV1 and EV2 have completed 45 min of mask prebreathe

Do not terminate prebreathe until cabin pressure at 10.2 psia and 1 hr mask prebreathe completed

EV

1. Momentarily pull mask away from face and verify O2 flow
  - \* If no positive O2 flow, contact MCC \*
2. Plot initial CABIN P vs PPO2 on 10.2 PSIA DEPRESS CHART using SM SYS SUMM 1

### WARNING

Cabin O2 concentration (SM SYS SUMM 1) must be maintained below 28.5% to protect against increased flammability risk

Terminate all WCS activity while flowing N2 thru 14.7 CAB REG INLET SYS 1

### NOTE

Expect klaxon each time airlock depress valve opened

AW82B, 3. START DEPRESS

MO10W Config vlvs per DEPRESS CHART

4. Continue plotting CABIN P vs PPO2 every 60 sec using SM SYS SUMM 1. Reconfig vlvs when plot transitions into different zone
5. STOP DEPRESS  
When CABIN P and PPO2 are in CONTROL ZONE (TARGET ZONE preferred), stop depress by configuring as listed at lower left of 10.2 PSIA DEPRESS CHART

### 10.2 PSIA DEPRESS CHART

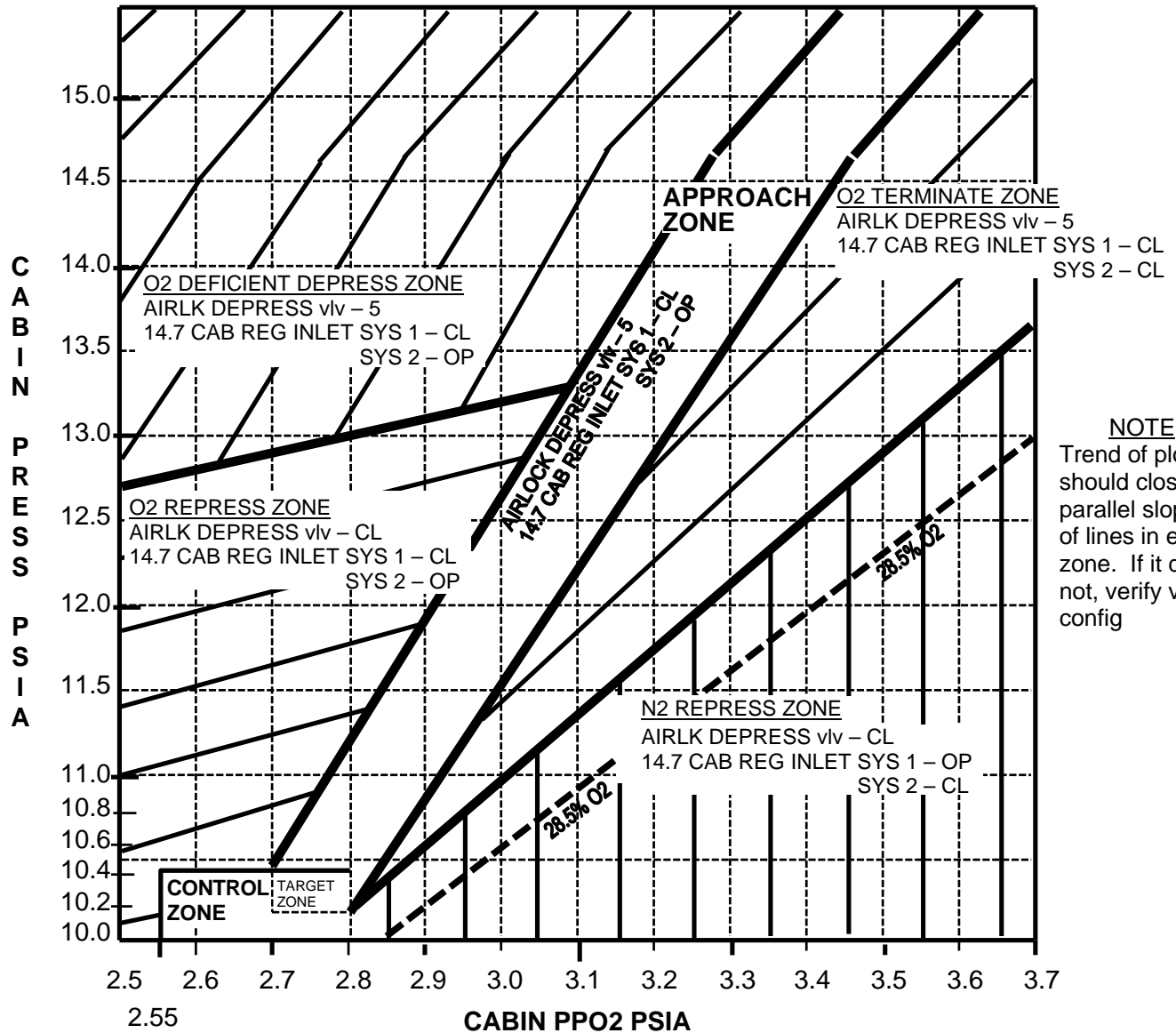

**NOTE**  
Trend of plot should closely parallel slope of lines in each zone. If it does not, verify valve config

When in **CONTROL ZONE**  
(**TARGET ZONE** preferred):  
**STOP DEPRESS**  
AIRLK DEPRESS vlv - CL  
Install AIRLK DEPRESS vlv Cap  
14.7 CAB REG INLET SYS 1 - CL  
SYS 2 - CL

## 10.2 PSI CABIN CONFIG

X: SM 60 SM TABLE MAINT

- R13
1. Reset FDA & C/W limits  
Changes enclosed in [ ]
  2. Contact MCC for uplink of B/U C/W and SM ALERT TMBU (if desired)

PARAMETER NAME	C/W CHL	H/W C/W		H/W & B/U ENA/INH	PARA ID	B/U C/W	
		LO V	HI V			LO EU	HI EU
CABIN PRESS (OV103)	4	2.50	2.70	ENA	0612405	10.0	10.6
(OV104)	4	2.50	2.70	ENA	0612405	10.0	10.6
(OV105)	4	2.45	2.65	ENA	0612405	10.0	10.6
PPO2 A	34	2.55	2.90	ENA	0612511	2.55	2.9
B	44	2.55	2.90	ENA	0612513	2.55	2.9
FAN ΔP	74	1.75	3.05	ENA	0612556	2.8	4.88

PARAMETER NAME	ENA/INH	PARA ID	SM ALERT	
			LOW	HIGH
OV-103				
AV BAY 1 FAN ΔP	ENA	0612642	2.40	3.80
AV BAY 2 FAN ΔP	ENA	0612647	1.90	3.60
AV BAY 3 FAN ΔP	ENA	0612658	2.50	3.80
OV-104				
AV BAY 1 FAN ΔP	ENA	0612642	1.90	3.80
AV BAY 2 FAN ΔP	ENA	0612647	1.90	3.70
AV BAY 3 FAN ΔP	ENA	0612658	2.40	3.90
OV-105				
AV BAY 1 FAN ΔP	ENA	0612642	2.40	3.80
AV BAY 2 FAN ΔP	ENA	0612647	1.90	3.60
AV BAY 3 FAN ΔP	ENA	0612658	2.50	3.90
IMU FAN ΔP	ENA	0612869	2.7	3.8

3. Perform SM CHECKPOINT INITIATE (ORB OPS, DPS)

L2 4. O2 XOVR SYS 2 – OP

5. If O2 bleed orifice not installed:

MO69M √LEH O2 vlv 8 – CL  
Unstow and insert O2 bleed orifice in O2 QD  
LEH O2 vlv 8 – OP

## MASK PREBREATHE TERMINATE

### WARNING

Do not terminate prebreathe until cabin pressure at 10.2 psia and 1 hr prebreathe completed

When mask prebreathe complete:

EV 1. Momentarily pull mask away from face to verify O2 flow

\* If no positive O2 flow, contact MCC \*

2. Set mask O2 control to NORMAL
3. Doff mask

C6,  
MO32M,  
MO69M 4. LEH O2 4(5,6,7) vlv – CL

MO39M 5. MIDDECK COMM CCU PWR – OFF  
outlet – Disconnect  
comm cable  
CCU PWR – ON

6. Depress Mask O2 control

C6,  
MO32M,  
MO69M 7. LEH O2 4(5,6,7) outlet – Disconnect hose

8. Stow mask, HIU, and 14 ft comm/O2 umbilical

## 10.2 PSI MAINTENANCE

### WARNING

Cabin O2 concentration (SM SYS SUMM 1) must be maintained below 28.5%. See chart this page

Terminate all WCS activity while flowing N2 thru 14.7 CAB REG INLET SYS 1

### CAUTION

Do not perform 10.2 PSI MAINTENANCE in parallel with EMU purge

X: SM SYS SUMM 1

### NOTE

Perform 10.2 PSI MAINTENANCE procedure post airlock repress and post sleep while 10.2 psi operations desired. Perform pre-sleep maintenance, if reqd, using target area in control zone

1. If PPO2 < 2.70 psia:  
If pre-sleep:  
OCAC Perform OCAC filter cleaning as reqd  
OCAC PWR – OFF  
C5 DIRECT O2 – OP
2. When PPO2 ~2.70 psia or when CABIN PRESS ~10.4 psia:  
DIRECT O2 – CL  
If pre-sleep:  
OCAC PWR – ON
3. If CABIN PRESS < 10.40 psia:  
MO10W 14.7 CAB REG INLET SYS 1 vlv – OP (N2)  
When CABIN PRESS ~10.40 psia:  
14.7 CAB REG INLET SYS 1 vlv – CL

### CABIN LEAK MONITORING

4. Log 10.2 PSI MAINTENANCE times (MET)
 

1. _____	5. _____
2. _____	6. _____
3. _____	7. _____
4. _____	8. _____

### NOTE

If MCC requests maintenance, then log time and use that time to compare to next maintenance

5. If successive maintenance reqd because CABIN PRESS decreased from 10.40 to 10.00 psia:  
For  $\Delta t < 40$  min, go to O2(N2) FLOW HIGH/CAB P LOW/dP/dT (ORB PKT, ECLS)  
For  $40 \text{ min} < \Delta t < 10 \text{ hr}$ , go to MAL, ECLS SSR-8, SMALL CABIN-LEAK ISOL

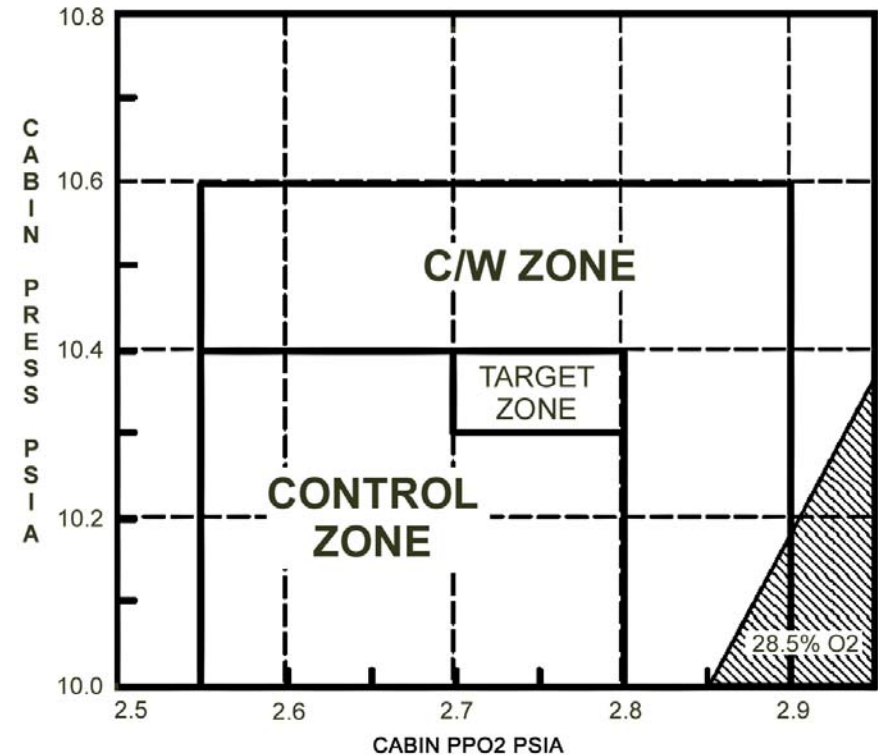

## CABIN REPRESS TO 14.7 PSI

**WARNING**  
 Terminate all WCS activity during repress  
 to 14.7 psia

### SETUP

X: SM 60 SM TABLE MAINT

- R13
1. Reset C/W and FDA limits
  2. Contact MCC for uplink of B/U C/W and SM ALERT TMBU (if desired)
- Changes enclosed in

PARAMETER NAME	C/W CHL	H/W C/W		H/W & B/U ENA/INH	PARA ID	B/U C/W	
		LO V	HI V			LO EU	HI EU
CABIN PRESS (OV103) (OV104) (OV105)	4	2.50	3.85	ENA	0612405	10.0	15.2
	4	2.50	3.85	ENA	0612405	10.0	15.2
	4	2.45	3.80	ENA	0612405	10.0	15.2
PPO2 A B	34	2.55	3.60	ENA	0612511	2.55	3.6
	44	2.55	3.60	ENA	0612513	2.55	3.6
FAN ΔP	74	1.75	4.25	ENA	0612556	2.8	6.8

PARAMETER NAME	ENA/INH	PARA ID	SM ALERT	
			LOW	HIGH
<b>OV-103</b>				
AV BAY 1 FAN ΔP	ENA	0612642	2.40	4.80
AV BAY 2 FAN ΔP	ENA	0612647	1.90	4.60
AV BAY 3 FAN ΔP	ENA	0612658	2.50	4.90
<b>OV-104</b>				
AV BAY 1 FAN ΔP	ENA	0612642	1.90	4.90
AV BAY 2 FAN ΔP	ENA	0612647	1.90	4.80
AV BAY 3 FAN ΔP	ENA	0612658	2.40	5.00
<b>OV-105</b>				
AV BAY 1 FAN ΔP	ENA	0612642	2.40	4.80
AV BAY 2 FAN ΔP	ENA	0612647	1.90	4.60
AV BAY 3 FAN ΔP	ENA	0612658	2.50	5.00
IMU FAN ΔP	ENA	0612869	2.7	4.95
H2O LOOP ICH OUT T1	ENA	0612744	33.0	
T2	ENA	0612724	33.0	

### REPRESS

X: SM 66 ENVIRONMENT

- MO10W 3. 14.7 CAB REG INLET SYS 1,2 vlv (two) – OP
- L2 4. √O2/N2 CNTLR VLV SYS 1 – OP  
2 – AUTO
5. Contact MCC to determine if FES should remain ON
6. If FES operation not reqd:
- L1 FLASH EVAP CNTLR PRI A(B) – OFF



## 14.7 PSI CABIN CONFIG

### ORBITER PCS 1(2) CONFIG

- MO10W
1. O2 REG INLET SYS 1(2) vlv – OP  
2(1) vlv – CL
  2. H2O TK N2 REG INLET SYS 1(2) vlv – OP  
2(1) vlv – CL
  3. √H2O TK N2 ISOL SYS 1,2 vlv (two) – OP
  4. If prior to shuttle airlock repress:  
14.7 CAB REG INLET SYS 1,2 vlv (two) – CL  
If after shuttle airlock repress:  
14.7 CAB REG INLET SYS 1(2) vlv – OP  
2(1) vlv – CL
- L2
5. O2/N2 CNTLR VLV SYS 1(2) – AUTO  
2(1) – CL(O2)

### RESET C/W AND FDA LIMITS

- R13U
6. Contact MCC for uplink of B/U C/W and SM ALERT TMBU (if desired)  
Changes enclosed in

PARAMETER NAME	C/W CHL	H/W C/W		H/W & B/U ENA/INH	PARA ID	B/U C/W	
		LO V	HI V			LO EU	HI EU
CABIN PRESS (OV103)	4	3.45	3.85	ENA	0612405	13.8	15.2
(OV104)	4	3.45	3.85	ENA	0612405	13.8	15.2
(OV105)	4	3.40	3.80	ENA	0612405	13.8	15.2
O2 FLOW (OV103,5)							
1	14		4.90	ENA	0612105		4.9
2	24		4.90	ENA	0612205		4.9
PPO2 A	34	2.7	3.60	ENA	0612511	2.7	3.6
B	44	2.7	3.60	ENA	0612513	2.7	3.6
N2 FLOW (OV103,5)							
1	54		4.90	ENA	0612553		4.9
2	64		4.90	ENA	0612554		4.9
FAN ΔP	74	2.60	4.25	ENA	0612556	4.2	6.8

PARAMETER NAME	ENA/INH	PARA ID	SM ALERT	
			LOW	HIGH
OV-103				
AV BAY 1 FAN ΔP	ENA	0612642	3.10	4.80
AV BAY 2 FAN ΔP	ENA	0612647	2.50	4.60
AV BAY 3 FAN ΔP	ENA	0612658	3.30	4.90
OV-104				
AV BAY 1 FAN ΔP	ENA	0612642	2.50	4.90
AV BAY 2 FAN ΔP	ENA	0612647	2.40	4.80
AV BAY 3 FAN ΔP	ENA	0612658	3.20	5.00
OV-105				
AV BAY 1 FAN ΔP	ENA	0612642	3.10	4.80
AV BAY 2 FAN ΔP	ENA	0612647	2.50	4.60
AV BAY 3 FAN ΔP	ENA	0612658	3.30	5.00
IMU FAN ΔP	ENA	0612869	3.7	4.95
CABIN O2 CONCENTRATION	ENA	0922104		25.9
AIRLK P	ENA	0640101	13.8	15.7
EXT AIRLK P	ENA	0640126	13.8	15.7
H2O LOOP ICH OUT T1	ENA	0612744	35.0	
T2	ENA	0612724	35.0	

7. Go to SM CHECKPOINT INITIATE (ORB OPS, DPS)

This Page Intentionally Blank

AIRLOCK CONFIG

AIRLOCK PREP .....	2-2
EMU SWAP .....	2-3
BOOSTER FAN DEACTIVATION/REMOVAL .....	2-4
INSTALLATION/ACTIVATION .....	2-4
EMU REMOVAL .....	2-4
INSTALLATION .....	2-4
CHECKOUT PREP .....	2-5
LTA RESTRAINT STRAP REMOVAL .....	2-6
INSTALLATION .....	2-6

**AIRLOCK  
CONFIG**

## AIRLOCK PREP (50 min)

	Retrieve or unstow following equipment:
MF28G	3/8-in breaker bar, 4-in ext w/3/8-in drive
IFM Tool Kit	1/2-in socket w/3/8-in drive
Vol H	EMU Equipment Bag – attach to middeck wall
	Helmet Lights
	EVA Bag
	Contamination Detection Kit (location flight specific)
FDF Locker	Cuff Checklists (2) – stow in EMU Equipment Bag
	<u>DEPRESS/REPRESS</u> Cue Card

- AW18A
1. ✓ Inner hatch Equal vlv (two) – OFF
  2. LTG FLOOD (four) – ON
  3. Remove from airlock, as reqd:
    - Airlock Stowage Bag
    - Airlock Floor Pallet using 3/8-in breaker bar, 4-in ext w/3/8-in drive, and 1/2-in socket w/3/8-in drive
  4. Stow Vol H Bags in Vol H
  5. Transfer to airlock:
    - EVA Bag – install on airlock wall
    - DEPRESS/REPRESS Cue Card
    - Helmet Lights
    - Contamination Detection Kit – install on airlock wall
  6. Install IVA foot restraint, as reqd
  7. Unbuckle SCU straps, Velcro SCU to wall
  8. Install EMU lights on helmets (EMU 1, EMU 2)
  9. Disconnect helmets from Airlock EMUs, temp stow
  10. Remove comm caps from LTA Restraint Bags and connect to electrical harnesses
  11. Install helmets (not reqd if proceeding directly to EMU Checkout)
  12. Remove LTA Restraint Bags
  13. Disconnect waist rings; remove and stow any equipment stowed in HUT/LTA
  14. Stow LTA Restraint Bags on AAPs
  15. ✓ Thermal cover clear of waist ring
  16. Waist ring – engage posn
  17. Connect LTA to HUT, lock
  18. Remove 20-g Crash Bag from middeck EMU, as reqd

AIRLOCK  
CONFIG

## EMU SWAP (30 min)

### NOTE

EMU X is to be removed and EMU Y is to be installed

- |       |  |  |
|-------|--|--|
| EMU X | 1. Install gloves  |  |
| AW18H | 2. √PWR/BATT CHGR EMU 1,2 BUS SEL (two) – OFF  |  |
|       | √MODE (two) – OFF  |  |
| DCM   | 3. Disconnect SCU, install DCM cover   |  |
|       | 4. Stow SCU on AAP, Velcro to wall   |  |
|       | 5. Connect LTA to HUT, lock (if reqd)  |  |
|       | 6. Disconnect helmet with sunshades down and helmet cover installed; stow              |  |
|       | 7. Release EMU from AAP, transfer EMU to middeck                                       |  |
|       | 8. Install helmet  |  |
|       | 9. Remove 20-g Crash Bag on middeck EMUs (if flown)                                    |  |
| EMU Y | 10. Disconnect helmet, temp stow   |  |
|       | 11. Remove comm cap from LTA Restraint Bag and connect to electrical harness (if reqd) |  |
|       | 12. Remove LTA Restraint Bag   |  |
|       | 13. Release EMU from middeck AAP, transfer to airlock                                  |  |
|       | 14. Mount EMU on AAP   |  |
|       | 15. Install helmets (not reqd if proceeding directly to EMU Checkout)                  |  |
|       | 16. Disconnect waist ring; remove and stow any equipment stowed in HUT/LTA             |  |
|       | 17. Waist ring – engage posn   |  |
|       | 18. Connect LTA to HUT, lock   |  |

### NOTE

O2 vlv for SCU connected to EMU Y must be closed prior to checkout of EMU Y

- |       |  |  |
|-------|--|--|
| AW82B | 19. If performing EMU CHECKOUT of EMU Y:<br>EV-1(EV-2) O2 vlv – CL |  |
| EMU X | 20. Attach EMU to middeck AAP                                      |  |
|       | 21. Attach LTA Restraint Bag                                       |  |

## **BOOSTER FAN DEACTIVATION/REMOVAL (15 min)**

- MO13Q 1. ARLK FAN A,B (two) – OFF  
MA73C:G 2. cb AC1,2 ARLK TNL FAN A,B (six) – op  
EXT A/L 3. Disconnect flex duct from booster fan muffler inlet, direct airflow into airlock, temp secure  
4. Disconnect vent duct from booster fan outlet and external airlock duct inlet; temp stow in middeck  
If booster fan to be removed:  
5. Disconnect flex duct from booster fan inlet; rotate and stow in launch bracket  
6. Demate booster fan electrical connectors from J1,J2 (two) on tunnel extension wall; loosen cable harnesses (two) from Velcro strips (four)  
7. Stow electrical connectors (two) on booster fan dummy fittings, secure cable harnesses with Velcro strips  
8. Loosen booster fan fasteners (four)  
9. Remove booster fan assy, temp stow in middeck

## **BOOSTER FAN INSTALLATION/ACTIVATION (15 min)**

- If booster fan to be installed:  
MA73C:G 1. √cb AC1,2 ARLK TNL FAN A,B (six) – op  
MO13Q 2. √ARLK FAN A,B (two) – OFF  
EXT A/L 3. Install booster fan assy, secure fasteners (four)  
4. Demate electrical connectors (two) from booster fan dummy fittings and Velcro strips  
5. Mate booster fan electrical connectors J1,J2 (two) on tunnel extension wall; secure cable harnesses (two) with Velcro strips (four)  
6. Unstow/connect flex duct from launch bracket to booster fan inlet  
7. Unstow/connect vent duct to external airlock duct inlet and booster fan outlet  
8. Unstow/connect flex duct from middeck to fan muffler inlet  
MA73C:G 9. cb AC1,2 ARLK TNL FAN A,B (six) – cl  
MO13Q 10. ARLK FAN A(B) – ON  
11. Check for airflow at top of external airlock halo

## **EMU REMOVAL (15 min)**

1. As reqd, install gloves
2. As reqd, perform LTA RESTRAINT STRAP INSTALLATION (AIRLOCK CONFIG)
3. As reqd, relocate LTA spring hooks (four) from AAP rings to SAFER mount brackets
4. Disconnect EMUs from AAPs, stow in middeck

## **EMU INSTALLATION (15 min)**

1. Transfer EMUs to A/L, connect to AAPs
2. As reqd for EVA, perform LTA RESTRAINT STRAP REMOVAL (AIRLOCK CONFIG)
3. As reqd, relocate LTA spring hooks (four) from SAFER mount brackets to AAP rings

## EMU CHECKOUT PREP (30 min)

- AW18A 1. LTG FLOOD (four) – ON
- 2. Remove Airlock Stowage Bag from airlock (if flown)
- Vol H 3. Unstow:
  - EMU Equipment Bag – attach to middeck wall |
  - EMU Servicing Kit – mark with Gray Tape; label “Shuttle”; temp stow
  - Drink Bags for later use (stow on top of Vol H Bags)
- 4. Stow Vol H Bags in Vol H
- 5. Unbuckle SCU straps, Velcro SCU to wall
- 6. Remove 20-g Crash Bag from middeck EMU (if flown)
- 7. Disconnect helmets from airlock EMUs, temp stow |
- 8. Remove comm caps from LTA Restraint Bags and connect to electrical harnesses in EMU
- 9. Remove LTA Restraint Bags
- 10. Disconnect waist rings; remove and temp stow any equipment stowed in HUT/LTA
- 11. Stow LTA Restraint Bags on AAP
- 12. ✓ Thermal cover clear of waist rings
- 13. Waist ring – engage position
- 14. Connect LTA to HUT, lock
- 15. Install helmet with sunshades down and helmet cover installed; lock (not reqd | if proceeding directly to EMU Checkout)

## LTA RESTRAINT STRAP REMOVAL (15 min)

### NOTE

May be performed on EMU 1 and 2 simultaneously.  
Perform steps as reqd for current EMU config

1. As reqd, remove comm cap from LTA Restraint Bag; temp stow
2. Remove EMU from AAP
3. Disconnect all restraint attachments from SAFER mount brackets (two)
4. Loosen cinch strap mechanism, remove SAFER mount brackets
5. Remove strap from PLSS
6. Stow strap in LTA Restraint Bag Pouch with D-rings (three) connected
7. Engage EMU in AAP
8. Stow LTA Restraint Bag/strap

## LTA RESTRAINT STRAP INSTALLATION (15 min)

### NOTE

May be performed on EMU 1 and 2 simultaneously. Perform steps as reqd for current EMU config. Procedure written to install in Launch/Landing config shown below

1. Unstow LTA Restraint Bag/strap
2. Remove EMU from AAP
3. Install SAFER mount brackets (two)
4. Install elastic band of strap around SOP
5. Tighten cinch strap mechanism
6. Attach strap French hooks (two) to SAFER mount brackets
7. Engage EMU in AAP
8. Stow LTA, suit arms inside LTA Restraint Bag
9. Connect upper spring hooks (two) over suit shoulders to upper AAP attachment rings (two)
10. Connect lower spring hooks (two) around suit arms to SAFER mount brackets (two)
11. Tighten all LTA bag straps with bag as high as possible on EMU

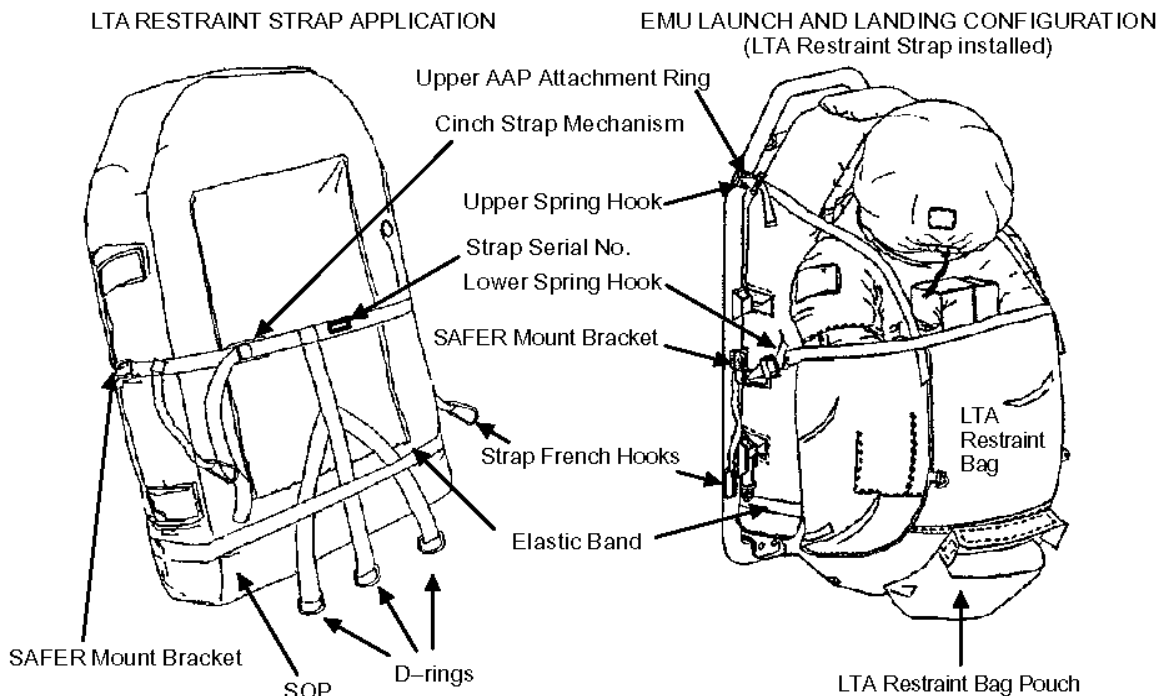

### NOTE

French hooks should be attached to SAFER mount brackets for launch and landing



## CHECKOUTS

EMU CHECKOUT .....	3-2
EMU POWERUP AND COMM CHECK .....	3-2
PRIMARY REGULATOR/FAN/PUMP CHECK .....	3-4
SOP CHECK .....	3-5
BATTERY CHARGE CHECK INIT .....	3-6
BATTERY CHARGE CHECK TERM.....	3-6
EMU SWAP DURING CHECKOUT .....	3-7
POST EMU C/O RECONFIG .....	3-7
SAFER CHECKOUT .....	3-8
SELF TEST SEQUENCE.....	3-9
SAFER CHECKOUT RESULTS .....	CC 3-10
SAFER STATUS TROUBLESHOOTING.....	CC 3-11
REBA POWERED HARDWARE CHECKOUT .....	3-12

**CHECKOUTS**

# EMU CHECKOUT

## NOTE

Procedures are written for simultaneous C/O of EMUs #\_\_\_\_\_ (stbd) and #\_\_\_\_\_ (port) in airlock. An additional C/O of EMU(s) #\_\_\_\_\_ uses same procedure after performing EMU SWAP during C/O

X: SM 60 SM TABLE MAINT

1. Contact MCC for uplink of SM ALERT TMBU (if desired)  
Changes enclosed in

Param Name	Param ID	Lower Limit	Upper Limit
EXT A/L H2O LINE T			
EXT A/L H2O SPLY ZN 1 T	0640181	43	100
EXT A/L LCG 2 SPLY ZN 1 T	0640182	36	85
EXT A/L H2O LINE T 2			
EXT A/L H2O SPLY ZN 2 T	0640184	48	100
EXT A/L LCG 2 SPLY ZN 2 T	0640185	36	82
EXT A/L O2 LN T			
EXT A/L O2 SPLY ZN 2 T	0640186	OSL	80
EXT A/L BATT CHARGER			
VOLTS EMU 1	0640210	OSL	OSH
VOLTS EMU 2	0640213	OSL	OSH

## EMU POWERUP AND COMM CHECK (15 min)

## NOTE

If procedure is being repeated for 3rd EMU #\_\_\_\_\_ only, other previously checked EMU #\_\_\_\_\_ is reqd in airlock to perform EMU POWERUP and COMM CHECK procedures to verify EMU-to-EMU comm.

PWR RESTART msg and BITE light should be illuminated whenever EMU power is cycled. Display and tone tests only occur during cold restarts

- BOTH DCM   2. Retrieve, position SCUs; remove DCM covers  
  3. Connect SCUs to DCM,  $\checkmark$ locked  
  4. PWR – BATT

## CAUTION

EMU must be on BATT pwr when airlock power supply is turned on

- AW18H   5. PWR/BATT CHGR EMU 1,2 MODE (two) – PWR  
 BUS SEL (two) – MNA(MNB)  
  6.  $\checkmark$ EMU INPUT 1,2 volts = 18.0-20.0  
 EV AW18D   7.  $\checkmark$ AIRLK AUD PWR – OFF  
 BOTH DCM   8. COMM mode – ALT  
  9.  $\checkmark$ Comm FREQ – LOW  
 IV A1R   10.  $\checkmark$ AUD CTR UHF A/G 1,2 (two) – OFF  
 A/A – T/R  
 R14:C   11.  $\checkmark$ cb MNA UHF EVA – cl  
 $\checkmark$ MNC UHF EVA – cl

CHECKOUTS

- R10      12. BIOMED CH 1 – EVA 1  
  CH 2 – EVA 2
- IVA ATU  13. √AUD PWR – AUD/TONE  
  A/G 1,2 (two) – OFF  
  A/A – T/R  
  ICOM A,B (two) – OFF (as reqd)
- O6        14. UHF SPLX/EVA PWR AMP – OFF  
  MODE – EVA
- BOTH    15. √Helmets disconnected  
           16. Don comm caps

NOTE

After the next step, be prepared to verify no missing segments on display and that all tones are audible

- 17. PWR – SCU
- 18. Verify no missing segments during display test  
Verify BITE light extinguishes  
Verify status (continuous) tone and warble tone are audible

Report any anomalies to MCC

- 19. Perform onboard A/A comm check per table

EMUs		IV O6:	
MODE	FREQ	EVA STRING	UHF SPLX/EVA XMIT FREQ
ALT	LOW	2	259.7/414.2
ALT	HIGH	2	296.8/417.1
PRI	HIGH	1	296.8/417.1
PRI	LOW	1	259.7/414.2

- IV     IVA ATU  20. AUD A/G 1(2) – T/R
- A1R    21. AUD CTR UHF A/G 1(2) – T/R  
  √A/G 2(1) – OFF  
  A/A        – OFF
- BOTH    22. Verify RF comm with MCC
- IV     A1R    23. AUD CTR UHF A/G 1(2) – OFF  
           24. Doff comm caps

If procedure is being repeated for 3rd EMU # \_\_\_\_\_ only, then on other  
previously checked EMU # \_\_\_\_\_:

- 25. Install helmet, lock
- 26. COMM mode – OFF
- 27. PWR/BATT CHGR EMU 1(2) BUS SEL – OFF  
  MODE     – OFF

- DCM    28. DISP – STATUS, until DATA?COMBO displayed  
          – YES (hold for 2 sec)  
          – STATUS, until DATA EMU? displayed  
          – YES (hold for 2 sec)  
Verify DATA?EMU displayed

PRIMARY REGULATOR/FAN/PUMP CHECK (40 min)

- MD(fir)   29. EMU O2 ISOL VLV – OP  
 DCM   30. √STATUS:  O2 P = 850-950

EMU	1	2	3	4
30. O2 P				

- AW82B   31. EV-1, EV-2 O2 vlv (two) – OP  
  32. Install helmet, lock  
  33. √Suit arms aligned  
  34. √Gloves locked  
 DCM   35. √Helmet purge vlv – cl, locked  
  36. PURGE vlv – cl (dn)  
  37. O2 ACT – IV  
  38. √STATUS:  SUIT P = 0.4-1.4 and stable (compare w/gauge)

EMU	1	2	3	4
38. SUIT P (IV)				

39. O2 ACT – PRESS  
  40. √STATUS:  SUIT P = 4.2-4.4 and stable (compare w/gauge)  
   H2O TEMP = ambient  
   H2O GP = 14.0-16.0  
   H2O WP = 14.0-16.0

EMU	1	2	3	4
40. SUIT P (PRESS)				
H2O TEMP				
H2O GP				
H2O WP				

41. DISP – STATUS, until  LEAK CHECK? displayed  
 DISP – YES (hold for 2 sec)  
 Follow displayed instructions

EMU	1	2	3	4
41. ΔP				

- \* If  LEAKAGE HI/ SUIT P msg occurs ( $\Delta P > 0.3$  psi), \*  
 \* go to FAILED LEAK CHECK (14.7/10.2 PSI) Cue \*  
 \* Card, CC 6-4 \*

- DCM   42. O2 ACT – OFF  
  43. PURGE vlv – op (up)  
  44. √STATUS:  SUIT P < 0.4 (compare w/gauge)  
  45. Disconnect glove  
  46. Reconnect glove  
  47. Disconnect helmet, temp stow  
  48. Disconnect waist ring – secure LTA to outer hatch handrail  
  49. Remove Multiple Water Connector cover, temp stow  
 DCM   50. Connect LCVG, √locked  
  51. √Temp control vlv – Max C

**CAUTION**  
Minimize fan operation with O2 ACT – OFF (~2 min)

52. FAN – ON (PWR RESTART may occur)  
Verify flow at neck ring vent port
- AW18H   53.  $\sqrt{\text{EMU INPUT amps}} = 1.5\text{-}4.7$  (1.5-5.0 at 14.7)

EMU	1	2	3	4
53. INPUT AMPS				

- DCM   54. Install SCOF, lock
55. O2 ACT – IV, **NO VENT FLOW** msg, DISP – PRO  
 $\sqrt{\text{Cooling flow in LCVG}}$
56.  $\sqrt{\text{STATUS: H2O TEMP}}$  decrease from step 40

EMU	1	2	3	4
56. H2O TEMP				

- \* If no temp decrease, depress and hold pump priming \*  
\* valve on back of EMU, while slowly cycling TCV \*  
\* between 7 and Max C (30 sec minimum) \*

- AW18H   57.  $\sqrt{\text{EMU INPUT amps}} = 1.5\text{-}3.6$  (1.5-4.0 at 14.7)  
 $\sqrt{\text{EMU INPUT amps decrease from step 53}}$

EMU	1	2	3	4
57. INPUT AMPS				

- DCM   58. PWR – BATT, **NO VENT FLOW** message, DISP – PRO
59.  $\sqrt{\text{STATUS: BAT VDC}} \geq 16.5$   
 $\sqrt{\text{BAT AMPS}} = 2.3\text{-}3.7$  (2.4-4.0 at 14.7)  
 $\sqrt{\text{RPM}} = 18.0\text{-}20.0$  K

EMU	1	2	3	4
59. BAT VDC				
BAT AMPS				
RPM				

60.  $\sqrt{\text{Fan noise steady}}$
61. O2 ACT – OFF
62. FAN – OFF
63. PWR – SCU

SOP CHECK (5 min)

64. Perform step 28 to reset data to EMU mode

- DCM   65.  $\sqrt{\text{STATUS: SOP P}} = 5410\text{-}6800$

EMU	1	2	3	4
65. SOP P				

SOP   66. √SOP gauge 5400-6800, note SOP interstage gauge

EMU	1	2	3	4
66. SOP GAUGE				
INT GAUGE				

DCM   67. DISP – STATUS until **SUIT P** displayed  
– YES (hold for 2 sec) to lock parameter

68. Depress SOP manual override (50 sec max):  
√SOP interstage gauge < 600  
DCM √STATUS: **SUIT P** = 3.4-3.9

EMU	1	2	3	4
68. SUIT P				
INT GAUGE				

69. √STATUS: **SOP P** = 5410-6800

EMU	1	2	3	4
69. SOP P				

- 70. Remove SCOF, stow
- 71. Disconnect LCVG, stow (as reqd if transferring to ISS)
- 72. Install Multiple Water Connector cover
- 73. Install helmet, LTA
- DCM   74. COMM mode – OFF

BATTERY CHARGE CHECK INIT (15 min)

AW18H   75. PWR/BATT CHGR EMU 1,2 BUS SEL (two) – OFF  
MODE (two) – CHARGE  
BUS SEL (two) – MNA(MNB)

76. Continue charge 15 min, minimum

BATTERY CHARGE CHECK TERM

When PWR/BATT CHGR EMU INPUT AMPS < 1 and 15 min minimum charge complete:

77. PWR/BATT CHGR EMU 1,2 BUS SEL (two) – OFF  
MODE (two) – OFF

EMU SWAP DURING CHECKOUT (30 min) (If reqd)

NOTE

EMU(s) # \_\_\_\_\_ to be removed from airlock.

EMU(s) # \_\_\_\_\_ to be installed in airlock.

Procedure written for swap of one or two EMUs

- EMU \_\_\_\_\_  78. ✓Gloves installed
- DCM \_\_\_\_\_  79. Disconnect SCU, install DCM cover
- 80. Stow SCU on AAP, Velcro to wall
- EMU \_\_\_\_\_  81. Release EMU from AAP, transfer EMU to middeck
- 82. Disconnect helmet, stow
- 83. Remove comm cap from LTA Restraint Bag and connect to electrical harness
- 84. Remove LTA Restraint Bag
- 85. Release EMU from middeck AAP, transfer to airlock
- 86. Install EMU on AAP
- 87. Disconnect waist ring; remove and stow any equipment stowed in HUT/LTA
- 88. Waist ring – engage posn
- 89. Connect LTA to HUT, lock

NOTE

O2 vlv for SCU connected to EMU(s) # \_\_\_\_\_ must be closed prior to checkout of EMU

- AW82B \_\_\_\_\_  90. EV-\_\_\_\_\_ O2 vlv – CL
- EMU \_\_\_\_\_  91. Install EMU on middeck AAP
- 92. Attach LTA Restraint Bag, as reqd
- 93. Go to EMU POWERUP AND COMM CHECK, 3-2

POST EMU C/O RECONFIG (5 min)

When EMU C/O for all EMUs complete:

- IV O6  94. UHF MODE – OFF
  - ✓SPLX/EVA XMIT FREQ – 259.7/414.2
  - ✓PWR AMP – OFF
  - ✓SPLX SQUELCH – ON
- R10  95. ✓BIOMED CH 1 – EVA 1
  - ✓CH 2 – EVA 2
- AW82B \_\_\_\_\_  96. EV-1, EV-2 O2 vlv (two) – CL
- BOTH DCM \_\_\_\_\_  97. Remove SCUs, install DCM covers
- 98. Stow SCU on AAP, Velcro to wall
- IV ML86B:C \_\_\_\_\_  99. cb MNC EXT ARLK HTR LINE ZN 1,2 (two) – cl  
(heaters will be deactivated on MCC call)

**X: SM 60 SM TABLE MAINT**

- 100. Contact MCC for uplink of SM ALERT TMBU (if desired)  
Changes enclosed in

Param Name	Param ID	Lower Limit	Upper Limit
EXT A/L H2O LINE T			
EXT A/L H2O SPLY ZN 1 T	0640181	43	145
EXT A/L LCG 2 SPLY ZN 1 T	0640182	49	145
EXT A/L H2O LINE T 2			
EXT A/L H2O SPLY ZN 2 T	0640184	48	145
EXT A/L LCG 2 SPLY ZN 2 T	0640185	45	145
EXT A/L O2 LN T			
EXT A/L O2 SPLY ZN 2 T	0640186	OSL	OSH

**SAFER CHECKOUT** (30 min if first checkout of SAFER unit,  
20 min for subsequent checks)

NOTE

Procedures written for simultaneous C/O of two SAFERs

- BOTH 1. Remove SAFER and SAFER CHECKOUT RESULTS Cue Card from Stowage Bag/FDF Locker
- PM 2. √Inhibitor installed, properly engaged
- If first SAFER CHECKOUT:
- HCM 3. Remove power switch guard
4. Stow HCM
5. Remove stowage straps from thruster towers, unfold towers
6. Remove SAFER latch guards from latches (leave lanyard straps attached to towers)
7. Inspect:  
Thruster tower hinges  
Tower latches  
√TMG not blocking thrusters  
√SAFER latch guard lanyard strap attached to SAFER towers above tower hinges
8. Peel back SAFER tower TMG on both towers and install SAFER latch guards over SAFER latches  
√Latch guard lanyards routed under tower TMG  
Re-attach tower TMG to secure latch guards in place
9. Fold thruster towers
- PM 10. Install stowage straps
11. MAN ISOL vlv – OP (dn)
12. Deploy HCM; √proper deployment

CAUTION

Minimize time with SAFER powered (~1 min)

NOTE

Have SAFER CHECKOUT RESULTS Cue Card w/proper serial number ready to record status.

From power on to entry into Test Mode, the SAFER will be in Automatic Attitude Hold (AAH) (Green LED on). Try to hold SAFER steady against a wall. Changes in SAFER attitude may result in AAH-induced thruster firings

13. As reqd, review SELF TEST SEQUENCE (refer to box next page)
- HCM 14. Perform Self Test:  
Start timer  
PWR – TST/ON  
Wait until GN2 XX% PWR XX% displayed  
√AAH LED (green) on  
PWR – ON

Cont next page



NOTE

Be prepared to count thruster clicks (24) after PWR – TST/ON

PWR – TST/ON

Follow displayed instructions on HCM:

√**SELF TEST – WAIT** displayed; if able, count thruster clicks (twenty four)

- \* If **NSI CIRCUIT OPEN** or **FAIL: ...** msg \*
- \* displayed or non-responsive display: \*
- \* Note failure msg \*
- \* Press DISP sw to resume test \*
- \* If **HC TO DETENT** msg displayed: \*
- \* Note msg \*
- \* √HC grip springs to center position \*

When **RATE CHECK** displayed, rotate SAFER at least + and - 3 deg/sec sequentially in each rotational axis

15. √**GO FOR EVA** or **FAILED TEST** displayed
16. PWR – ON
17. DISP: Record GN2%, PWR%, BATT V (SAFER CHECKOUT RESULTS Cue Card)
18. PWR – OFF
19. Stop timer, record 'ON Time' (~1 min desired)
20. √GN2% ≥ 87  
√PWR% ≥ 45  
√BATT V ≥ 35
21. Report GN2%, PWR%, BATT V, and SAFER serial number to MCC
- HCM 22. MODE – ROT

CAUTION

Do not stow HCM to be used for EVA with power switch guard installed

NOTE

When stowing HCM, verify that umbilical will not snag during deployment

23. Stow HCM
24. Stow SAFER and Cue Card in Stowage Bag
25. √Inhibitor installed
26. MAN ISOL vlv – CL (up)

<b>SELF TEST SEQUENCE (for reference only; do not perform)</b>	
HCM	1. NSI circuit test
	2. <b>SELF TEST – WAIT</b> ; √Twenty-four thruster clicks and THR LED (red) flashing
	3. <b>DEPRESS AAH</b>
	4. <b>MODE – ROT</b> (if in TRAN) <b>MODE – TRAN</b>
	5. HC grip detent test
	6. <b>HC +X</b> (fwd), (-X, +Y (rt), -Y, +Z (dn), -Z, +P (twist up), -P)
	7. <b>RATE CHECK</b> ; rotate SAFER at least + and - 3 deg/sec sequentially in each rotational axis

HOOK  
VELCRO

HOOK  
VELCRO

**SAFER CHECKOUT RESULTS**

SAFER SERIAL # \_\_\_\_\_

	GMT	ON Time	GN2%	PWR%	BATT V		GMT	ON Time	GN2%	PWR%	BATT V
1						27					
2						28					
3						29					
4						30					
5						31					
6						32					
7						33					
8						34					
9						35					
10						36					
11						37					
12						38					
13						39					
14						40					
15						41					
16						42					
17						43					
18						44					
19						45					
20						46					
21						47					
22						48					
23						49					
24						50					
25						51					
26						52					

**NOTE**

SAFER battery expected to last for 52 1-min checkouts and have at least 45% PWR remaining

**BATTERY CHANGEOUT**

GMT	OLD BATT SERIAL #	NEW BATT SERIAL #

EVA-3a/O/C

TOP  
(Back of 'SAFER CHECKOUT RESULTS')

**HOOK  
VELCRO**

**HOOK  
VELCRO**

**SAFER STATUS TROUBLESHOOTING**

GMT					
Failure Message					NOMINAL STATUS
GN2%					87-99%
PWR%					45-99%
TANK P					> 6575 psia
TANK T					-40 to 140 degF
RATE R					± 30 deg/s
RATE P					± 30 deg/s
RATE Y					± 30 deg/s
DISPL R					± 99.9 deg
DISPL P					± 99.9 deg
DISPL Y					± 99.9 deg
BATT V					≥ 35.0 V
BATT T					50 to 90 degF
Leak					NO LEAK

GMT					
Failure Message					NOMINAL STATUS
GN2%					87-99%
PWR%					45-99%
TANK P					> 6575 psia
TANK T					-40 to 140 degF
RATE R					± 30 deg/s
RATE P					± 30 deg/s
RATE Y					± 30 deg/s
DISPL R					± 99.9 deg
DISPL P					± 99.9 deg
DISPL Y					± 99.9 deg
BATT V					≥ 35.0 V
BATT T					50 to 90 degF
Leak					NO LEAK

**SAFER JET NOMENCLATURE**

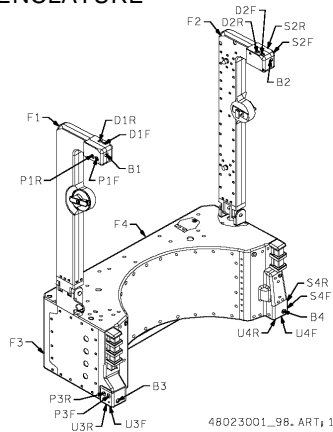

EVA-3b/O/D

(reduced copy)

## REBA POWERED HARDWARE CHECKOUT (15 min)

### NOTE

Procedure written for simultaneous C/O of 12 volt HDW on all EMUs

- 1. Perform REBA BATTERY INSTALL (EMU MAINT/RECHARGE), as reqd
- All EMUs   2. √REBA sw (1 per EMU) – OFF (toward left arm of suit)
- If EMU TV:
  - 3. Install EMU TV on helmets 1,2; note camera addresses EV1 \_\_\_\_, EV2 \_\_\_\_ (see figure below)
- PLSS   4. Unstow EMU TV power cable, disconnect from ground plug
- 5. Mate EMU TV power cable to EMU TV
- If no EMU TV:
  - PLSS   6. √EMU TV power cable mated to ground plug
  - 7. √Upper arm connections mated
  - 8. √Glove heater sw (one per glove) – OFF
  - 9. Connect lower arm pwr harness to gloves

### NOTE

To avoid excessive battery consumption and heat buildup, deactivate heaters once heat detected at fingertips

- 10. REBA sw (1 per EMU) – ON, pull tab toward right arm of suit
- 11. Glove heater sw (one per glove) – ON
- When heat detected on all outside fingertips:
  - 12. Glove heater sw (one per glove) – OFF
- If EMU TV:
  - 13. EMU TV power pb – press, √Green LED illuminated
  - 14. EMU TV power pb – press, √Green LED not illuminated
- 15. REBA sw (1 per EMU) – OFF, pull tab toward left arm of suit
- 16. Disconnect lower arm pwr harness from gloves
- 17. Stow lower arm and glove pwr harness connectors under TMG
- 18. Disconnect EMU TV power cable from EMU TV
- PLSS   19. Connect EMU TV power cable to ground plug
- 20. Attach LTA Restraint Bag, as reqd

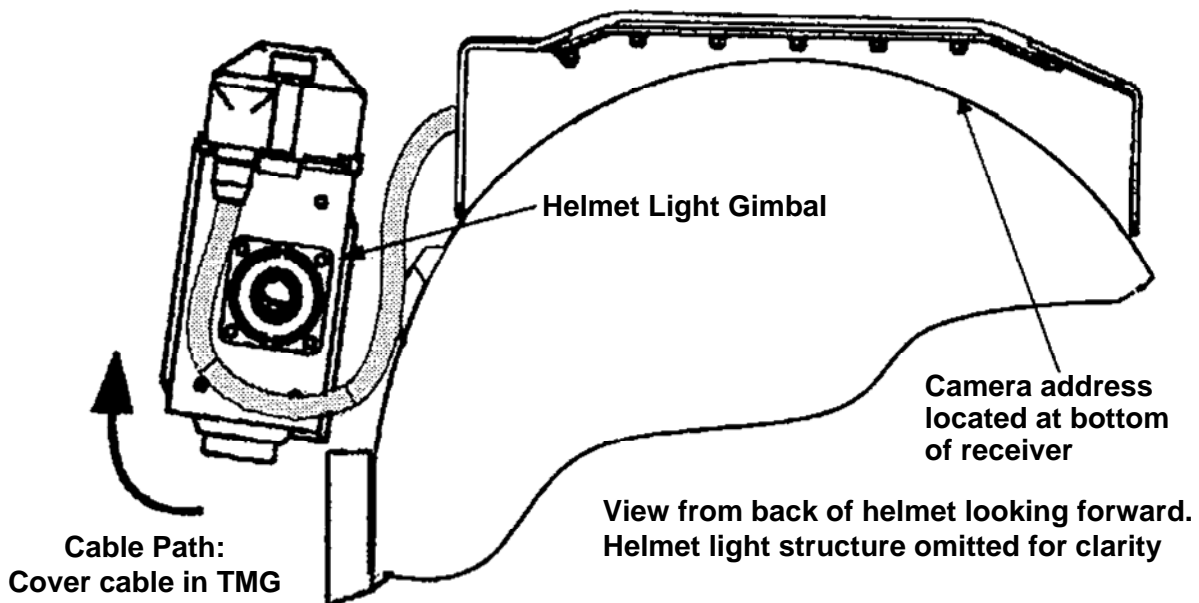

EVA PREP

MIDDECK PREP.....	4-2
EVA PREP .....	4-3
PREP FOR DONNING .....	4-3
EMU DONNING .....	4-5
EMU CHECK.....	4-7
EMU PURGE .....	4-7
EMU PREBREATHE.....	4-8
SAFER DONNING .....	4-8
EVA COMM CONFIG .....	4-10
EVA COMM DECONFIG .....	4-10
APPROVED NON-EMU HARDWARE MATRIX .....	4-11

**WARNING**

Payload bay floods exceed EMU thermal limits during operation. If EVA crew will be operating in vicinity of PLB floods, floods must be turned off now. Cooldown time may be as long as 6 hr

**NOTE**

Wireless Video Heater pwr should be activated at least 4 hr before EVA to ensure quality video

**MIDDECK PREP (30 min)**

- A7 1. WIRELESS VID HTR – ON
- Vol H 2. Unstow EMU Servicing Kit
- AW18A 3. LTG FLOOD (four) – ON
- 4. √EVA Bag installed in airlock
- 5. √Contamination Detection Kit installed in airlock
- 6. √REBA sw – OFF (toward left arm of suit)
- 7. √Helmet lights, helmet light batteries, and EMU TVs installed on helmets  
If EMU TV:
- PLSS 8. √EMU TV power cable demated, connected to ground plug
- 9. Disconnect helmets, temp stow
- HUT 10. Remove Drink Bag Restraint Bag

**NOTE**

Drink bag should be used within 24 hr if filled with non-iodinated water

- 11. Fill drink bag from galley with cold water, remove gas and insert drink bag in Restraint Bag
- 12. Install Drink Bag Restraint Bag in HUT and dispose of fill tool in wet trash
- 13. Unstow comm cap and inspect moisture barrier earphone diaphragms (MBEDs) (two) for damage. Replace if reqd (EMU Servicing Kit)
- 14. Apply anti-fog (EMU Servicing Kit), wipe off:  
Helmets (not Fresnel lens)  
EV glasses, attach to comm cap
- 15. Stow EMU Servicing Kit
- 16. Install helmets, lock
- 17. Attach Cuff C/L to EMUs
- 18. √Wrist mirrors installed
- 19. Stage crew preference items in EMU Equipment Bag as reqd

**CAUTION**

EV crewmembers should minimize application of hygiene and hydrocarbon-based products prior to EVA day to avoid introduction of irritants into EMU. Reference APPROVED NON-EMU HARDWARE MATRIX, 4-11, for acceptable items in EMU

**EVA PREP**

**EVA PREP (90 min)**

MET ____/____:____	MET ____/____:____	MET ____/____:____
--------------------	--------------------	--------------------

**X: SM 60 SM TABLE MAINT**

1. Contact MCC for uplink of SM ALERT TMBU (if desired)  
Changes enclosed in

<u>Param Name</u>	<u>Param ID</u>	<u>Lower Limit</u>	<u>Upper Limit</u>
EXT A/L H2O LINE T			
SPLY ZN 1 T	0640181	43	<input style="width: 40px; text-align: center;" type="text" value="100"/>
LCG 2 SPLY ZN 1 T	0640182	<input style="width: 40px; text-align: center;" type="text" value="36"/>	<input style="width: 40px; text-align: center;" type="text" value="85"/>
H2O LINE T 2			
SPLY ZN 2 T	0640184	48	<input style="width: 40px; text-align: center;" type="text" value="100"/>
LCG 2 SPLY ZN 2 T	0640185	<input style="width: 40px; text-align: center;" type="text" value="36"/>	<input style="width: 40px; text-align: center;" type="text" value="82"/>
O2 LN T			
SPLY ZN 2 T	0640186	OSL	<input style="width: 40px; text-align: center;" type="text" value="80"/>

**PREP FOR DONNING (30 min)**

- |      |         |  |  |
|------|---------|--|--|
| BOTH | DCM     | <input type="checkbox"/> <input type="checkbox"/> <input type="checkbox"/> | 2. Retrieve, position SCU; remove DCM cover      |
|      |         | <input type="checkbox"/> <input type="checkbox"/> <input type="checkbox"/> | 3. Connect SCU to DCM, $\sqrt$ locked            |
|      | AW82B   | <input type="checkbox"/> <input type="checkbox"/> <input type="checkbox"/> | 4. EV-1, EV-2 O2 vlv (two) – op                  |
|      | MO13Q   | <input type="checkbox"/> <input type="checkbox"/> <input type="checkbox"/> | 5. $\sqrt$ ARLK H2O S/O VLV – OPEN (tb-OP)       |
|      | MD(flr) | <input type="checkbox"/> <input type="checkbox"/> <input type="checkbox"/> | 6. $\sqrt$ EMU O2 ISOL VLV – OP                  |
|      | ML86B:C | <input type="checkbox"/> <input type="checkbox"/> <input type="checkbox"/> | 7. $\sqrt$ cb MNC EXT ARLK HTR ZN 1,2 (two) – op |
|      | L2      | <input type="checkbox"/> <input type="checkbox"/> <input type="checkbox"/> | 8. $\sqrt$ O2 XOVR SYS 1,2 (two) – OP            |
| BOTH | DCM     | <input type="checkbox"/> <input type="checkbox"/> <input type="checkbox"/> | 9. PWR – BATT                                    |

**CAUTION**  
EMU must be on BATT pwr when  
airlock power supply turned on

- |       |  |  |
|-------|--|--|
| AW18H | <input type="checkbox"/> <input type="checkbox"/> <input type="checkbox"/> | 10. PWR/BATT CHGR EMU 1,2 MODE (two) – PWR<br>BUS SEL (two) – MNA(MNB)   |
| DCM   | <input type="checkbox"/> <input type="checkbox"/> <input type="checkbox"/> | 11. PWR – SCU  |
|       | <input type="checkbox"/> <input type="checkbox"/> <input type="checkbox"/> | 12. $\sqrt$ STATUS: <input style="width: 60px; text-align: center;" type="text" value="BATT VDC"/> $\geq$ 20.3 |
|       | <input type="checkbox"/> <input type="checkbox"/> <input type="checkbox"/> | 13. Verify panels as shown next page   |

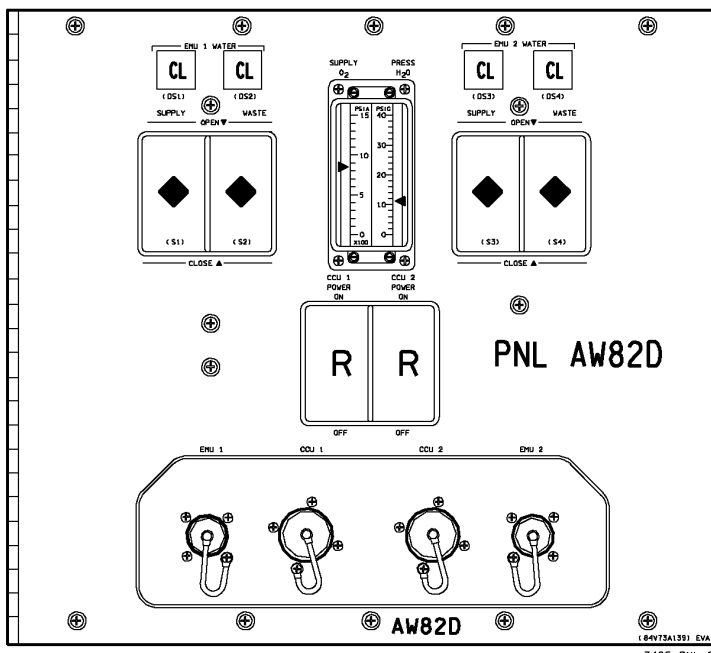
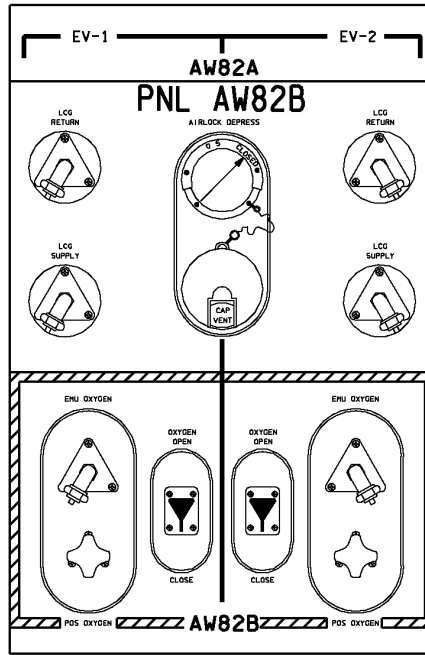
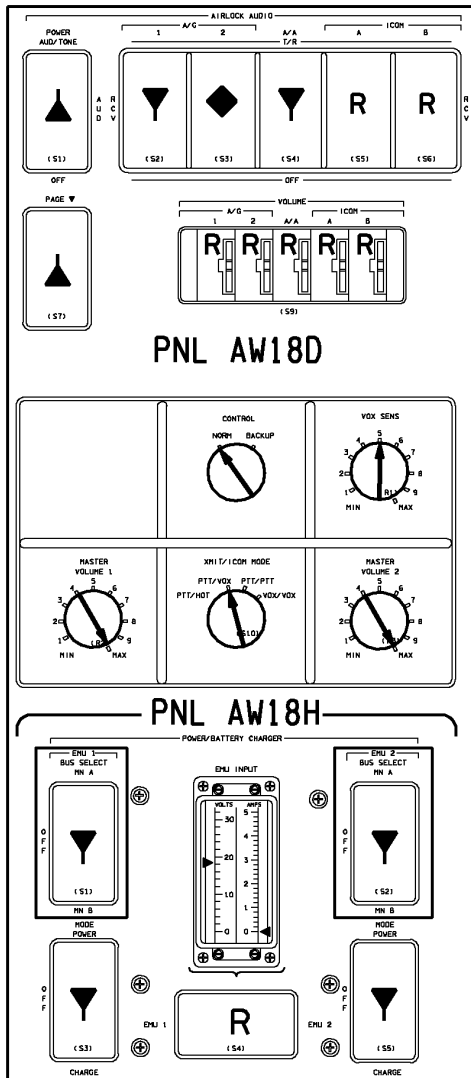



- |      |     |  |  |
|------|-----|--|--|
| IV   |     | <input type="checkbox"/> <input type="checkbox"/> <input type="checkbox"/> | 14. Perform EVA COMM CONFIG, steps 1-4   |
| BOTH | DCM | <input type="checkbox"/> <input type="checkbox"/> <input type="checkbox"/> | 15. Comm FREQ – LOW  |
|      |     | <input type="checkbox"/> <input type="checkbox"/> <input type="checkbox"/> | 16. COMM mode – PRI (EMU data only, no audio)  |
|      |     | <input type="checkbox"/> <input type="checkbox"/> <input type="checkbox"/> | 17. Disconnect, transfer, temp stow LTAs, helmets, additional EMU(s) to middeck  |
|      |     | <input type="checkbox"/> <input type="checkbox"/> <input type="checkbox"/> | 18. Remove Dosimeter from inflight garments; insert in LCVG  |
|      |     | <input type="checkbox"/> <input type="checkbox"/> <input type="checkbox"/> | 19. Unstow biomed OBS/EVA cable (EMU Servicing Kit), connect to elec harness   |
|      |     | <input type="checkbox"/> <input type="checkbox"/> <input type="checkbox"/> | 20. Don MAG, TCU, LCVG   |
|      |     | <input type="checkbox"/> <input type="checkbox"/> <input type="checkbox"/> | 21. Don biomed per figure; shave 3-in patch using shave gel and razor (as reqd) (EMU Servicing Kit), clean skin using shave gel and damp towel, dry skin, install stoma seals and apply paste to electrodes, adhere to chest and secure with overtapes |
|      |     | <input type="checkbox"/> <input type="checkbox"/> <input type="checkbox"/> | 22. Don comm caps  |
|      |     | <input type="checkbox"/> <input type="checkbox"/> <input type="checkbox"/> | 23. Connect biomed to elec harness   |
| IV   |     | <input type="checkbox"/> <input type="checkbox"/> <input type="checkbox"/> | 24. Perform EVA COMM CONFIG, steps 5 and 6 (EMU hot mic)   |
|      |     | <input type="checkbox"/> <input type="checkbox"/> <input type="checkbox"/> | 25. Verify biomed signal, EMU data, and RF comm with MCC   |
| BOTH | DCM | <input type="checkbox"/> <input type="checkbox"/> <input type="checkbox"/> | 26. COMM mode – HL   |

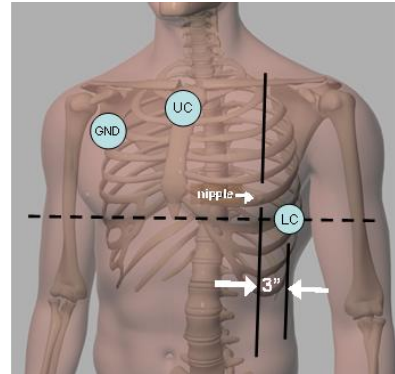

EVA BIOMED PLACEMENT

NOTE

Be prepared to verify a nominal powerup sequence after the next step and verify no missing segments on display and that all tones are audible

- |       |  |  |  |
|-------|--|--|--|
|       |  | <input type="checkbox"/> <input type="checkbox"/> <input type="checkbox"/> | 27. PWR – BATT<br>Verify no missing segments during display test<br>Verify status (continuous) tone and warble tone audible<br>Verify BITE light extinguishes. Report anomalies to MCC |
|       |  | <input type="checkbox"/> <input type="checkbox"/> <input type="checkbox"/> | 28. PWR – SCU  |
|       |  | <input type="checkbox"/> <input type="checkbox"/> <input type="checkbox"/> | 29. Doff comm caps   |
|       |  | <input type="checkbox"/> <input type="checkbox"/> <input type="checkbox"/> | 30. Disconnect biomed  |
| AW18D |  | <input type="checkbox"/> <input type="checkbox"/> <input type="checkbox"/> | 31. AIRLK AUD PWR – AUD/TONE   |

EMU DONNING (55 min)

NOTE

May be performed by EV1 and EV2 simultaneously

- |      |  |  |  |
|------|--|--|--|
| BOTH |  | <input type="checkbox"/> <input type="checkbox"/> <input type="checkbox"/> | 32. Take one aspirin tablet (325 mg)   |
|      |  | <input type="checkbox"/> <input type="checkbox"/> <input type="checkbox"/> | 33. √STATUS: <span style="border: 1px solid black; padding: 2px;">SOP P</span> = 5410-6800 (compare w/gauge) |
| EV1  |  | <input type="checkbox"/> <input type="checkbox"/> <input type="checkbox"/> | 34. √Waist ring – op   |
|      |  | <input type="checkbox"/> <input type="checkbox"/> <input type="checkbox"/> | 35. Don LTA, attach donning handles as reqd<br>If boot bladder manipulation reqd:                            |
|      |  |  | 36. Disconnect boot from leg (sizing ring)   |
|      |  |  | 37. Pull up excess boot bladder around full circumference of boot disconnect                                 |
|      |  |  | 38. Connect boot to leg (sizing ring)  |
|      |  |  | 39. Engage Lock 1  |
|      |  |  | 40. √All locks (three per boot) engaged  |

- 41. Ingress airlock
- 42. ✓Suit arms aligned
- 43. Disconnect gloves; ✓wrist disconnects – op
- 44. Stow IV glasses
- 45. Don thumb loops
- 46. ✓Drink valve posn before HUT donning
- 47. ✓Biomed elec harness outside of HUT
- PLSS    48. ✓REBA sw – OFF
- 49. Don HUT
- 50. Release thumb loops
- 51. ✓Suit arms aligned
- 52. Don EV glasses as reqd
- 53. Don comm cap
- DCM    54. ✓COMM mode – HL, vol as reqd
- 55. ✓Comm with IV
- 56. Connect biomed to elec harness
- 57. Connect LCVG to multiple water connector, ✓locked
- 58. ✓Thermal cover clear of waist ring
- 59. Waist ring – engage posn
- 60. Connect waist ring to HUT, ✓locked
- 61. Remove donning handles, stow in EMU Equipment Bag; cover waist ring

**CAUTION**  
 Pulling on drink bag blue bite vlv to adjust posn can cause vlv to release from stem

- 62. ✓Drink vlv posn after HUT donning
- 63. ✓Mike boom posn
- 64. Don comfort gloves, wristlets
- 65. Wrist rings – engage posn
- 66. Don EV gloves, ✓locked
- 67. Tighten palm restraint straps

If REBA battery:

- IV    68. ✓Glove heater sw (two) – OFF
- 69. Connect lower arm pwr harness to gloves
- 70. Stow slack under arm TMG
- 71. ✓Cuff C/L posn

**CAUTION**  
 Minimize fan operation with O2 ACT – OFF (~2 min)

- EV1 DCM    72. FAN – ON (PWR RESTART may occur)
- 73. ✓Elec harness clear of neck ring
- 74. Don helmet, ✓locked
- DCM    75. O2 ACT – IV
- 76. ✓Helmet purge vlv – cl, locked
- DCM    77. PURGE vlv – cl (dn)
- If EMU TV:
- PLSS    78. Unstow EMU TV power cable; disconnect from ground plug
- 79. Mate EMU TV power cable to EMU TV
- EV2    80. Repeat steps 33-79 if done serially

**EMU CHECK (5 min)**

BOTH  81. √Cooling

- \* If cooling insufficient slowly cycle temp control vlv \*
- \* between 7 and Max C while IV depresses and holds \*
- \* pump priming vlv on back of EMU (30 sec min) \*

82. Temp control vlv – as reqd
83. √Wrist rings – covered
84. √Waist rings – covered
- DCM  85. √COMM mode – HL
86. √WATER – OFF
87. √PWR – SCU
88. √FAN – ON
89. √Comm FREQ – LOW
90. √Helmet Light ops
91. √Helmet purge vlv – cl, locked

DCM  92. √PURGE vlv – cl (dn)

93. DISP – STATUS: until **LEAK CHECK?** msg displayed  
DISP –YES (hold for 2 sec), follow displayed instructions

- \* If **PRESS FAIL/SUIT P X.X** or **LEAKAGE HI | SUIT P X.X**, \*
- \* go to **FAILED LEAK CHECK (14.7/10.2 PSI)**, CC 6-4 \*
- \* (Cue Card) \*

**EMU PURGE**

MET / :   MET / :   MET / :

**NOTE**

Flex arms and legs periodically and avoid overcooling during purge/prebreathe

CABIN P	PURGE DURATION (min)
10.2	8
14.7	12

- BOTH DCM  1. O2 ACT – PRESS
2. Verify no EMU fit issues
3. PURGE vlv – op (up), begin purge clock
4. When N2 purge complete (per table):  
PURGE vlv – cl (dn)  
O2 ACT – IV

# EMU PREBREATHE

MET ____/____:____	MET ____/____:____	MET ____/____:____
--------------------	--------------------	--------------------

- IV R1  1. Begin prebreathe clock
- 2. O2 TK3 HTR A(B) – as reqd
- 3. Egress AAP, stow handles
- IV AW82B  4. AIRLK DEPRESS vlv cap –  
vent, remove, stow
- 5. Remove loose equipment
- 6. If reqd, stow REBA jumper cable

CABIN P		PREBREATHE DURATION
10.2	12 hr	01:15
	24 hr	00:40
14.7		04:00

**SAFER DONNING (If reqd)**

- IV  7. Remove SAFER from Stowage Bag
- 8. Remove stowage straps from thruster towers, stow in EMU Equipment Bag; unfold thruster towers
- 9. Remove SAFER latch guard from SAFER latch (leave lanyard strap attached to thruster tower)
- 10. Inspect:
  - Thruster tower hinges
  - Tower latches
  - √TMG not blocking thrusters
  - √SAFER latch guard lanyard strap attached to SAFER towers above tower hinges
- PM  11. √TMG clear from SAFER striker plate on EMU PLSS
- 12. Remove Inhibitor; close, fasten port cover
- 13. MAN ISOL vlv – OP (dn)
- 14. Latch – PRELOAD
- 15. Rotate latch ccw to recess butterfly in housing

**CAUTION**  
Rotating ccw past soft stop can bind latch

- 16. Rotate latch ccw to soft stop
- If reqd:
  - 17. Rotate latch cw to align latch collar with square bolt head
- 18. Latch – ENG
- 19. Mate PLSS to thruster towers
- 20. Push latch in and rotate cw until stop (~90°)
  - \* If latch will not engage: \*
  - \* Latch – PRELOAD \*
  - \* Rotate latch ccw until soft stop \*
  - \* Return to step 17 \*
- 21. Latch – PRELOAD
- 22. Rotate latch cw until ratcheting

**CAUTION**  
Rotating ccw may disengage SAFER

- 23. Continue ratcheting until lock marking on latch, tower aligned
- 24. Latch – LCK
- 25. Peel back SAFER tower TMG on both towers and install SAFER latch guards over SAFER latches
  - √Latch guard lanyards routed under tower TMG
  - Re-attach tower TMG to secure latch guards in place
- 26. √Latch butterfly is perpendicular to slot on PLSS
- 27. √Access to HCM deploy lever
- 28. √TMG not blocking thruster
- 29. Repeat for SAFER 2

- As reqd per MCC,  
Set battery amp-hours:
- EV1, EV2  
DCM             30. DISP – STATUS until BATT? 32.0AH displayed  
 31. DISP – YES (hold for 2 sec)  
 32. Use DISP to status to desired value  
 33. When desired value selected, DISP – YES (hold for 2 sec)
- IV             34. Install MWS and BRTs (as reqd)  
If DCS 760 EVA camera used:  
Charger     35. SW2 CAMERA PWR – OFF (LED off)  
DCS 760     36. Disconnect DCS 760 pwr cable from DC PWR ADAPTER port  
               37. Close thermal cover on DC PWR ADAPTER port or connect Ext Camera pwr cable to DC PWR ADAPTER port (as reqd)  
EVA Flash  38. Install flash batteries (two) (as reqd)  
 39. ✓EVA tools installed in airlock  
 40. As reqd, perform BOOSTER FAN DEACTIVATION/REMOVAL (AIRLOCK CONFIG)
- A/L         41. Remove, stow appropriate vent ducts to allow hatch closure  
MD(flr)     42. As reqd, disconnect vent duct from middeck floor fitting; stow  
               43. As reqd, unstow, install diffuser cap on middeck floor fitting  
 44. ✓Loose middeck-stowed items clear of inner hatch and middeck diffuser cap air flow
- DCM         45. Remove WATER switch guard (two), stow in EMU Equipment Bag  
               46. REBA sw – ON (toward right arm of suit)  
If EMU TV:  
               47. EMU TV power pb – press, ✓Green LED illuminated
- If airlock with aft hatch:  
A/L(flr)     48. Deploy floor EVA hatch supports  
 49. Egress airlock  
 50. Inner hatch – close, lock  
 51. ✓Inner hatch Equal vlv caps (two) – removed  
 52. Inner hatch Equal vlv (two) – OFF  
 53. When prebreathe time complete, ✓MCC for GO to DEPRESS/REPRESS (Cue Card)

## EVA COMM CONFIG

- R14:C 1. √cb MNA UHF EVA – cl  
√MNC UHF EVA – cl
- O6 2. √UHF SPLX/EVA XMIT FREQ – 259.7/414.2  
√PWR AMP – OFF  
√EVA STRING – 1  
UHF MODE – EVA
- IVA ATU 3. √AUD A/G 1(2) – T/R
- R10 4. BIOMED CH 1 – EVA 1  
2 – EVA 2

If docked with ISS and EVA comm on A/G 1:

### NOTE

In step 5, A/G 1 docked hardline disabled.  
UHF will become A/G 1 Shuttle-to-ISS link

5. √MCC and ISS that UHF configured and in  
Public Call

A1R AUD CTR SPACELAB A/G 1 – OFF

- A1R 6. AUD CTR UHF A/G 1(2) – T/R  
√2(1) – OFF  
√A/A – OFF

## EVA COMM DECONFIG

- O6 1. UHF MODE – OFF  
√SPLX/EVA XMIT FREQ – 259.7/414.2  
√PWR AMP – OFF  
√SPLX SQUELCH – ON
- If docked with ISS and EVA comm on A/G 1:
- A1R 2. AUD CTR SPACELAB A/G 1 – ON
3. AUD CTR UHF A/G 1(2) – OFF  
√2(1) – OFF  
√A/A – OFF

## APPROVED NON-EMU HARDWARE MATRIX

Item	Part Number	Item	Part Number	Item	Part Number
Passive Dosimeter	SED11100212	Band-Aids	8137004444	Genoptic Ophthalmic Ointment	17478-284-35
Panty Shield	S019BY2033	Band-Aids	8137004431	JAXA Crew Personal Dosimeter (JaCPD)	CPADLESXXX
Sock	528-40802	Band-Aids	8137004430	Kerlix Dressing	6715
Sock	ST11C802	Band-Aids	09681	Kerlix Dressing	K6715
Sock Liner	ST17C3309	Band-Aids	555-3036	Kling Dressing	6923
Hair Restraint	528-41572-XX	Band-Aid Sheer Dot	4930	Lidocaine Jelly	186033036
Croakie – Modified	528-21224	Band-Aid Strips	NON256602	Lotrimin Cream	0085-0963-17
GRD Croakie	CP-3-XX-XX1-XX	Band-Aid Sheer Spot	555-8243	Moleskin	528-4304-1
Croakie	528-41822	Benzoin Swabs	26-06-09	Mosite	1028
European Crew Personal Dosimeter	EuCPD-FM-XXX-XXX	Benzoin Swabs	26-06-19	Neosporin Plus Cream	0501-3712-05
Eye Glasses	CP-3-XX-XX-XX	Bioclusive	2461	Polysporin Ointment	81079887
OBS Cable	SED42100961	Blistex	1015798221	Polytrim	23782410
OBS Signal Cond	16843	Blistex	10157-9920-2	Povidone Iodine Swabs	26-02-86
OBS Sternal Harness	SH42100149	Ciloxan 0.3%	0065-0654-35	Pred Forte	1198018001
OBS Sternal Harness	SH46115992	Ciloxan Ointment	65065625	Proparacaine	998001615
OBS Sternal Harness	13726	Ciprofloxacin Ointment	0065-0654-35	Providone-Iodine Swabs	4335260286
MBED	528-21260	Clotrimazole Cream	5167212751	Silvadene Cream	88105020
Russian Dosimeter	IBMP-CPD-001	Cortisporin Ophthalmic	615003675	Silvadene Cream	61570-131-20
3" Ace Bandage	23593-130	Coverlet	01307	Steri-Strip	R1547
4" Ace Bandage	54251A7	Coverlet	47135	Steri-Strip	R1546
6" Ace Bandage	54252A7	Coverlets	01306	Tears Naturale	65041830
4" x 4" Gauze	555-6284	Cyclogyl	65039715	Tegaderm	1624W
4" x 4" Vaseline Gauze	8884-414600	Dermabond	DB12	Tegaderm Dressing	1626
Adapttec Dressing	K6112	Dermabond	301128243	Telfa Pads	890-2865
Adapttec Non-adhering Dressing	2012	Dermicel Tape	5143	Tobrex Solution	65064305
Afrin Nasal Spray	8575608	Dermicel Tape	5144	Topicort	99207-011-15
Auralgan	46100010	Elastoplast Tape	23631-040X	Triamcinolone Acetonide Dental Paste	5167212675
Bacitracin	2438506003	Eye Pads	J8773	Triamcinolone Cream	4580206435
Bactroban Ointment	0029-1527-22	Famciclovir	0007-4117-13	VIROPTIC	61570-037-75
Bactroban Ointment	29152544	Gauze Pads	2337	Zovirax Ointment	73099394
		Gauze Pads	555-6284		

This Page Intentionally Blank



EMU STATUS

EMU STATUS

# EMU STATUS

## EMU STATUS

I

PARAMETER	NORMAL STATUS	EV1	EV2	EV1	EV2	EV1	EV2
O2 POS	EVA						
SUBLM P	2.0 to 4.2 psia						
TIME EV	HR:MIN since PWR-BATT						
TIME LF	HR:MIN remaining at present use rate						
%PWR (O2) LF	Limiting consumable displayed						
%O2 (PWR) LF	Nonlimiting consumable displayed						
SUIT P	4.2 to 4.4 psid						
	(4.2 to 5.5 psid post depress)						
O2 P	150 to 950 psia						
O2 RATE	0 to 4.0 psi/min						
SOP P	5410 to 6800 psia						
BAT VDC	≥ 16.7						
BAT AMP	3.0 to 4.0						
RPM	18.0 to 20.0 K						
CO2	0.2 to 4.0 mmHg						
H2O TEMP	32 to 75 degF						
H2O GP	14.0 to 16.0 psid						
H2O WP	14.0 to 16.0 psid						
DATA?	COMBO						
BATT	32.0 AH (or as directed)						
GAUGE	4.2 to 4.4 psid						
	(4.2 to 5.5 psid post depress)						

**EMU Status Short Stack:** Used to periodically (every hour for the first 6.5 hr, then every 10 min) report to MCC-H if the EMU data downlink is not available

PARAMETER	EV	EV	EV	EV	EV	EV	EV	EV
TIME EV								
TIME LF								
%PWR (O2) LF								
%O2 (PWR) LF								

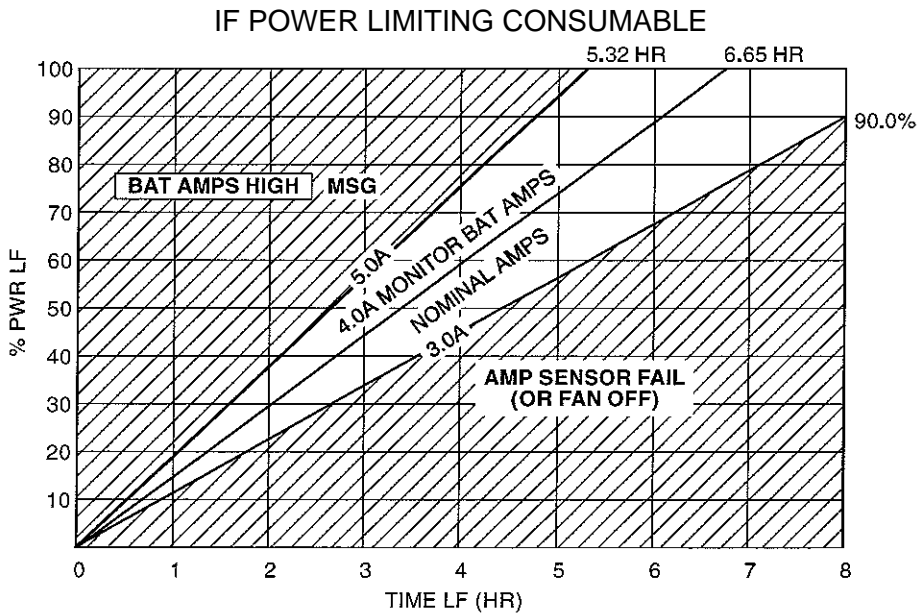
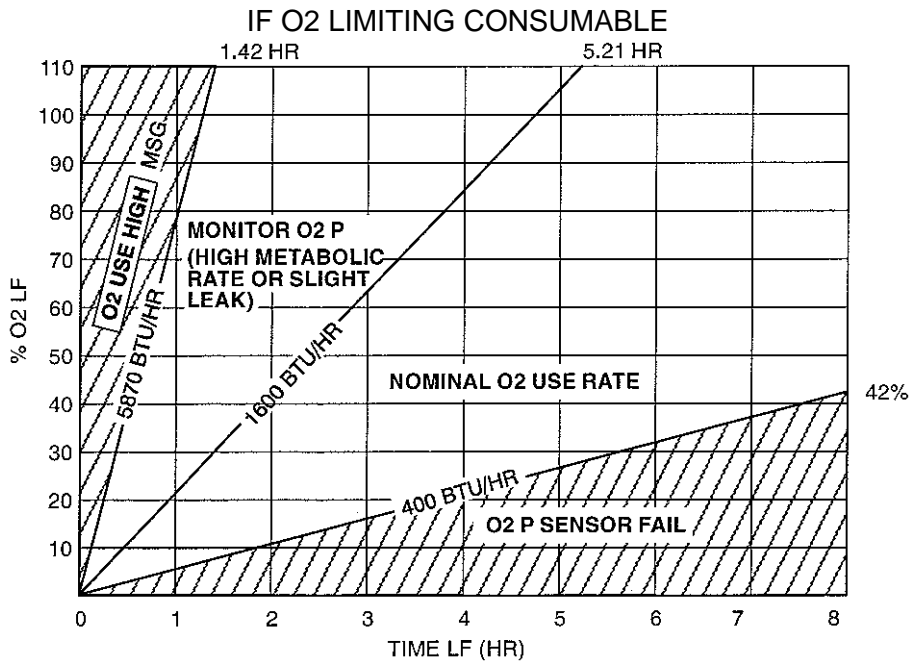

This Page Intentionally Blank

DEPRESS/  
REPRESS

DEPRESS/REPRESS

**NOM AIRLOCK**

A6-1

EVA/NOM/GEN H

TOP

HOOK VELCRO	DEPRESS/REPRESS	HOOK VELCRO
<p><b>DEPRESS (10 min)</b> When prebreathe complete</p> <p>DCM 1. √Comm FREQ – LOW 2. COMM mode – PRI</p> <p>AW82B 3. AIRLK DEPRESS vlv – 5, EV ALERT TONE, monitor suit P gauge &lt; 5.5 * If gauge &gt; 5.5, stop depress, √MCC *</p> <p>4. Airlock at 6.0, EV ALERT TONE</p> <p>5. When airlock at 5.0, AIRLK DEPRESS vlv – CL, EV ALERT TONE</p> <p>BOTH DCM 6. DISP – STATUS: until <u>LEAK CHECK ?</u> displayed, DISP – YES (hold for 2 sec), follow displayed instructions * If <u>LEAKAGE HI   SUIT P X.X</u>, go to <u>FAILED</u> * * <u>LEAK CHECK (5 PSI)</u>, reverse side *</p> <p>7. √O2 ACT – EVA</p> <p>AW82B 8. AIRLK DEPRESS vlv – 0, EV ALERT TONE, monitor suit P gauge &lt; 5.5 * If gauge &gt; 5.5, stop depress, √MCC *</p> <p>9. Attach waist tether(s) to A/L D-ring for egress</p> <p>BOTH 10. Airlock dP/dT ~0, EV ALERT TONE 11. When outer hatch ΔP &lt; 0.5, outer hatch – open, stow</p> <p>AW82B 12. AIRLK DEPRESS vlv – CL</p>	<p><b>PRE REPRESS (5 min)</b></p> <p>IV ML86B:C 1. √cb MNC EXT ARLK HTR LINE ZN 1,2 (two) – op</p> <p>MD(flr) 2. √EMU O2 ISOL vlv – OP</p> <p>DCM 3. √SCUs connected to DCM 4. √WATER – OFF for 2 min</p> <p>BOTH 5. √Outer hatch closed and locked 6. Disc waist tethers, attach to EMU</p> <p>AW82B 7. √EV-1, EV-2 O2 vlv (two) – OP</p> <p>AW18H 8. PWR/BATT CHGR EMU 1,2 BUS SEL (two) – MNA(MNB)</p> <p>DCM 9. PWR – SCU, EV WARN TONE (IV record MET __:__:__)</p>	<p><b>REPRESS (10 min)</b></p> <div style="border: 2px solid black; padding: 5px; text-align: center;"> <p><b>WARNING</b> If on SOP, leave O2 ACT – EVA thru airlock repress</p> </div> <p>BOTH DCM 1. O2 ACT – PRESS 2. COMM mode – HL</p> <p style="text-align: center;"><b>NOTE</b> IV expect dP/dT alarm during repress</p> <p>AW82B 3. √AIRLK DEPRESS vlv – CL 4. Inner hatch Equal vlv (one) – throttle OFF to NORM (as reqd), EV ALERT TONE 5. Airlock at 4.0, EV ALERT TONE 6. When airlock at 5.0, Equal vlv – OFF, EV ALERT TONE</p> <p>DCM 7. √Airlock pressure integrity (2 min, ΔP ≤ 0.1 psi) 8. √EV Glove heaters – OFF, gloves clean</p> <div style="border: 2px solid black; padding: 5px; text-align: center;"> <p><b>WARNING</b> If Cuff 1 symp resolve upon repress, report as Cuff 2 If any DCS, leave O2 ACT – PRESS</p> </div> <p>DCM 9. O2 ACT – IV 10. Inner hatch Equal vlv (one) – NORM, EV ALERT TONE 11. Airlock dP/dT ~0, EV ALERT TONE 12. Go to <u>POST EVA</u></p>
<p><b>POST DEPRESS (5 min)</b></p> <p>BOTH DCM 1. PWR – BATT, EV WARN TONE (IV record MET __:__:__) <u>PET = 00:00</u></p> <p>AW18H 2. PWR/BATT CHGR EMU 1,2 BUS SEL (two) – OFF</p> <p>3. Disc SCU; install DCM cover</p> <p>4. Stow SCU on AAP, Velcro to wall</p> <p>DCM 5. Temp control vlv – Max H 6. WATER – ON 7. √DCM blank, BITE off 8. Temp control vlv – 3 to MAX C 9. √STATUS, compare to Cuff C/L, 1 (IV record)</p> <p>10. Visors as reqd</p> <p>11. Perform AIRLOCK EGRESS, Cuff C/L, 47, or Flight Specific Timeline</p> <p>IV ML86B:C 12. cb MNC EXT ARLK HTR LINE ZN 1,2 (two) – cl</p>	<p>EVA-1a/NOM/O/J</p>	

DEPRESS/REPRESS

TOP

<p>HOOK VELCRO</p>	<p>DEPRESS/REPRESS</p>	<p>HOOK VELCRO</p>
<p><b>DEPRESS (25 min)</b> When prebreathe complete</p> <p>DCM 1. √Comm FREQ – LOW 2. COMM mode – PRI</p> <p>AW82B 3. AIRLK DEPRESS vlv – 5, EV ALERT TONE, monitor suit P gauge &lt; 5.5 * If gauge &gt; 5.5, stop depress, √MCC *</p> <p>4. Airlock at 6.0, EV ALERT TONE</p> <p>5. When airlock at 5.0, AIRLK DEPRESS vlv – CL, EV ALERT TONE</p> <p>BOTH DCM 6. DISP – STATUS: until <u>LEAK CHECK ?</u> displayed, DISP – YES (hold for 2 sec), follow displayed instructions * If <u>LEAKAGE HI   SUIT P X.X</u>, go to <u>FAILED</u> * * <u>LEAK CHECK (5 PSI)</u>, reverse side *</p> <p>7. √O2 ACT – EVA</p> <p>8. √MCC for aft module pressure integrity</p> <p>AW82B 9. AIRLK DEPRESS vlv – 0, EV ALERT TONE, monitor suit P gauge &lt; 5.5 * If gauge &gt; 5.5, stop depress, √MCC *</p> <p>10. Airlock dP/dT ~0, EV ALERT TONE</p>	<p><b>PRE REPRESS (5 min)</b></p> <p>IV ML86B:C 1. √cb MNC EXT ARLK HTR LINE ZN 1,2 (two) – op</p> <p>MD(flr) 2. √EMU O2 ISOL vlv – OP</p> <p>BOTH DCM 3. √WATER – OFF 4. √EVA hatch closed, locked 5. Unstow SCU, remove DCM cover, connect SCU, √locked</p> <p>6. Disc waist tethers, attach to EMU</p> <p>AW82B 7. √EV-1, EV-2 O2 vlv (two) – OP</p> <p>AW18H 8. PWR/BATT CHGR EMU 1,2 BUS SEL (two) – MNA(MNB)</p> <p>DCM 9. PWR – SCU, EV WARN TONE (IV record MET _ _ : _ _)</p>	<p><b>REPRESS (20 min)</b></p> <div style="border: 2px solid black; padding: 5px; text-align: center;"> <p><b>WARNING</b> If on SOP, leave O2 ACT – EVA thru airlock repress</p> </div> <p>BOTH DCM 1. O2 ACT – PRESS 2. COMM mode – HL</p> <p style="text-align: center;"><b>NOTE</b> IV1 expect dP/dT alarm during repress</p> <p>AW82B 3. √AIRLK DEPRESS vlv – CL 4. Inner hatch Equal vlv (one) – throttle OFF to NORM (as reqd), EV ALERT TONE</p> <p>5. Airlock at 4.0, EV ALERT TONE</p> <p>6. When airlock at 5.0, Equal vlv (two) – OFF, EV ALERT TONE</p> <p>DCM 7. √Airlock pressure integrity (4 min, <math>\Delta P \leq 0.1</math> psi) 8. √EV Glove heaters – OFF, gloves clean</p> <div style="border: 2px solid black; padding: 5px; text-align: center;"> <p><b>WARNING</b> If Cuff 1 symp resolve upon repress, report as Cuff 2 If any DCS, leave O2 ACT – PRESS</p> </div> <p>DCM 9. O2 ACT – IV 10. Inner hatch Equal vlv (one) – NORM, EV ALERT TONE</p> <p>11. Airlock dP/dT ~0, EV ALERT TONE</p> <p>12. Go to <u>POST EVA</u></p> <p style="text-align: right;">EVA-2a/TNL/O/V</p>
<p>HOOK VELCRO</p>	<p>HOOK VELCRO</p>	



FAILED LEAK CHECK

HOOK  
VELCRO

HOOK  
VELCRO

**FAILED LEAK CHECK (5 PSI)**

BOTH  
IV Inner Hatch  
DCM

1. Leaking EMU: Repeat leak check on watch and gauge as follows:  
O2 ACT – PRESS until SUIT P = 4.2 to 4.4 and stable, compare with gauge then  
O2 ACT – IV, start timing  
(1 min, Max ΔP = 0.3 psi)
2. If leak check passed:  
Return to DEPRESS/REPRESS Cue Card,  
DEPRESS, step 7 (suit pressure sensor unreliable) >>
3. O2 ACT – IV
4. Equal vlv (one) – NORM  
When ΔP < 0.5, open inner hatch  
Equal vlv (one) – OFF
5. Repeat leak check as follows:  
√PURGE vlv – cl (dn)  
O2 ACT – PRESS, until SUIT P = 4.2 to 4.4 and stable, compare with gauge then  
O2 ACT – IV, start timing  
(1 min, Max ΔP = 0.3 psi)
6. Contact MCC

EVA-1b/O/J  
EVA-2b/O/J

**FAILED LEAK CHECK (14.7/10.2 PSI)**

NOTE

The following steps are performed on the leaking EMU only

IV

1. Leaking EMU: O2 ACT – PRESS
2. Rotate lower arm assemblies 180 degrees cw and 360 degrees ccw
3. Align suit arms
4. √Sizing rings locked
5. Swivel hips from side to side
6. Repeat leak check as follows:  
√Helmet purge vlv – cl, locked  
√PURGE vlv – cl (dn)  
√O2 ACT – PRESS until SUIT P = 4.2–4.4 and stable (compare w/gauge)  
O2 ACT – IV, start timing, 1 min  
(during EMU CHECKOUT, 2 min)  
(Max ΔP = 0.3 psi)
7. If leak check passed, go to step 11  
If leak check failed:  
PURGE vlv – op (up), O2 ACT – OFF  
FAN – OFF (if EVA PREP)  
Cycle/inspect suit disconnects as follows:  
Gloves, helmet (leave off), LTA, boots  
(if removed in EVA PREP)  
FAN – ON (if EVA PREP)
8. Install helmet, repeat leak check step 6, then:
9. If leak check passed, go to step 11  
If leak check failed:  
PURGE vlv – op (up), O2 ACT – OFF  
FAN – OFF (if EVA PREP)  
Cycle/inspect suit disconnects as follows:  
Gloves, helmet (leave off)  
Helmet purge vlv, Sizing rings  
LiOH cartridge (O-rings)  
FAN – ON (if EVA PREP)
10. Install helmet, repeat leak check step 6, then:
11. If leak check passed:  
√Waist ring, wrist rings covered  
Continue EMU CHECKOUT or  
EVA PREP >>
12. If leak check failed (EMU lost):  
Contact MCC

DCM

DCM

DCM

HOOK  
VELCRO

HOOK  
VELCRO

FLIGHT SPECIFIC TIMELINES

This Page Intentionally Blank

TOOLS AND STOWAGE

PORT LIGHTWEIGHT TOOL STOWAGE ASSEMBLY (TSA) .....	8-2	
PGT CHECKOUT .....	8-3	
PGSC-PGT CONNECTION (A31P AND 760XD) .....	8-4	
PROGRAM PGT SETTINGS .....	8-5	
DOWNLOAD/ERASE EVENT LOG .....	8-5	
PGT CONTINGENCIES.....	8-6	
PGT STANDARD SETTINGS.....	8-7	

TOOLS AND  
STOWAGE

# PORT LIGHTWEIGHT TOOL STOWAGE ASSEMBLY (TSA)

I

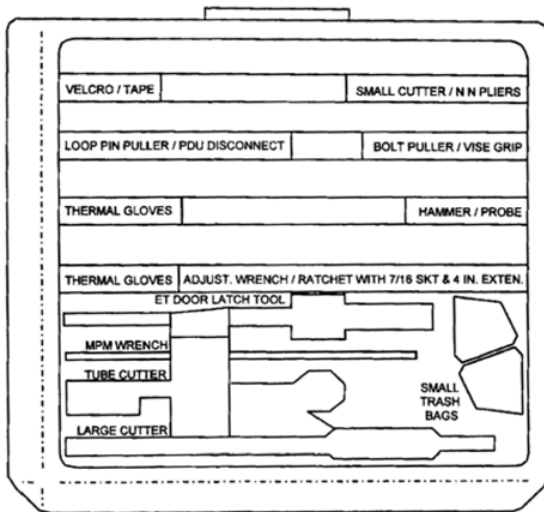
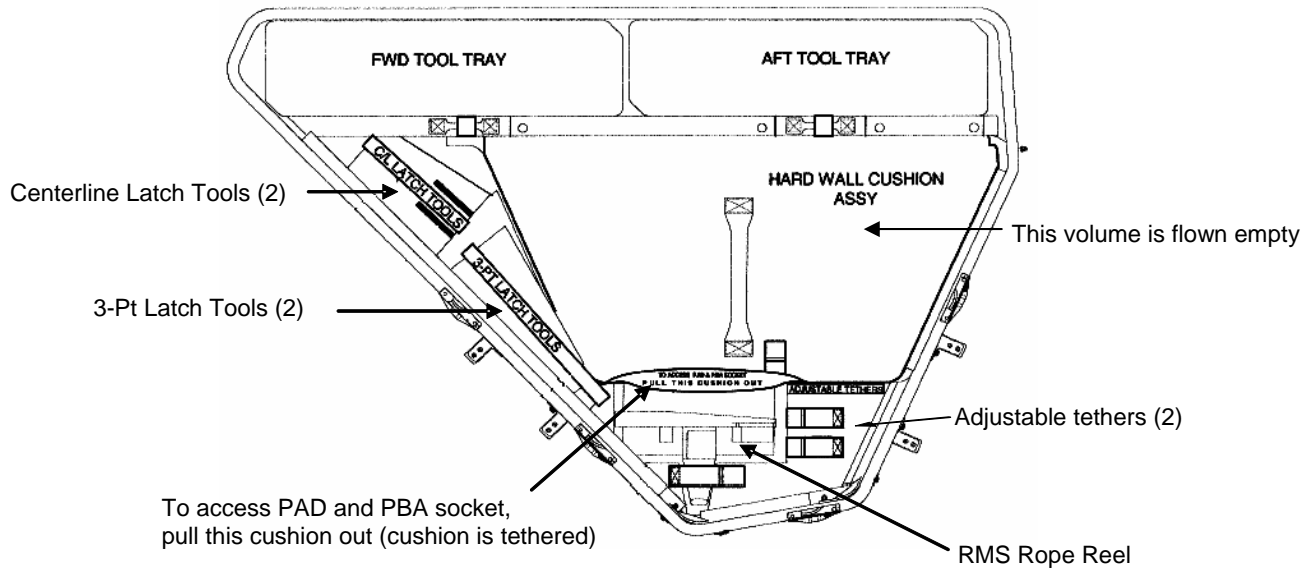

Forward Tray layout and Labels

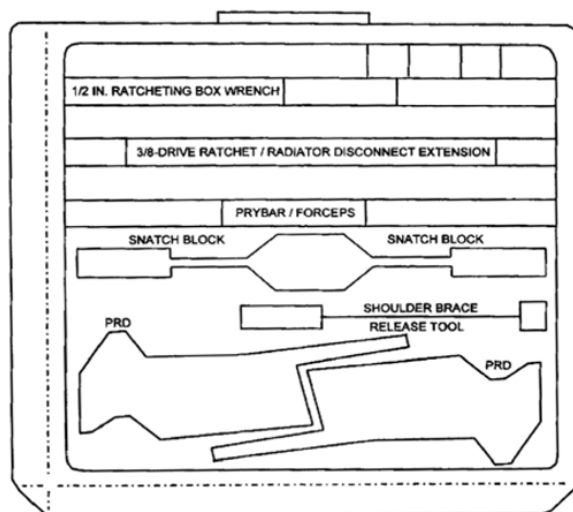

Aft Tray Layout and Labels



TOOLS AND STOWAGE

## PGT CHECKOUT

1. Unstow PGT
2. ✓PWR – OFF
3. ✓Battery connector covering removed
4. Install battery
5. Ratchet collar – not MTR
6. Cycle MTL settings
7. Cycle bayonette fittings
8. Speed collar – CAL
9. PWR – ON
10. ✓'TRIG TO CAL' on display
11. Press, release trigger to calibrate
12. ✓'CAL PASSED' on display
13. Ratchet collar – MTR
14. ✓Illumination of all LEDs and 'LED TEST' displayed
15. Press trigger and hold
  - ✓BATT VDC  $\geq$  36.0
16. Speed collar – cw
17. Press trigger and ✓drive rotates cw
18. Speed collar – ccw
19. Press trigger and ✓drive rotates ccw
20. To verify programmed settings, cycle MODE/torque collar/speed collar and compare with PGT SETTINGS TABLE
21. PWR – OFF

## PGSC-PGT CONNECTION (A31P AND 760XD)

- PGSC
- PGT
1. ✓PGSC equipped with RS422 PCMCIA Card and adapters (two)
  2. ✓PWR – OFF
    - ✓PGT Battery installed
  3. Ratchet collar – not MTR

**CAUTION**  
Do not over-torque serial port cover screw

- PGSC
- PGT
- PGSC
4. Open PGT serial port cover using 3/32" Allen Wrench attached to the PGT-RS422 Cable
  5. Connect PGT-RS422 Cable to PGT Remote Programming Port
  6. Connect PGT-RS422 Cable to COM 2 or COM 4 adapter box, as desired
  7. PWR – ON
  - If PGSC not powered:
    8. PGSC PWR – ON
  9. Select SHUTTLE APPS icon on PGSC Windows desktop, then select either 'PGT (COM 2)' or 'PGT (COM 4)' icon  
(Use PGT icon corresponding to COM port selected in step 6)
  10. ✓Tool Communication Check dialog box appears
    - ✓Serial Connection verified
    - ✓Intool software version 2.2

- \* If dialog box in previous step indicates failure to read software version or
- \* reports a communication error, verify electrical connections are fully
- \* mated at identified locations below (1-5), then clear dialog box, close
- \* application, and repeat steps 9 and 10

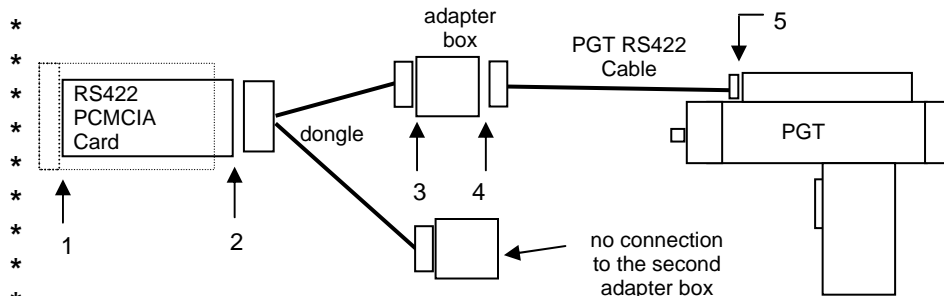

- \* 1 = RS422 PCMCIA Card to PGSC (check PC card is fully engaged)
- \* 2 = RS422 PCMCIA Card to dongle
- \* 3 = dongle to adapter box
- \* 4 = adapter box to PGT RS422 Cable
- \* 5 = PGT RS422 cable to PGT Remote Programming Port

11. Select CONTINUE



## PROGRAM PGT SETTINGS

1. Perform PGSC-PGT CONNECTION (A31P AND 760XD)
- If loading settings from a set file in C:\SPOCAPPS\PGT32\SETTINGS:
2. Select FILE, OPEN ...
  3. Select desired settings file, OPEN
  4. Select TORQUE/REVOLUTIONS SETTINGS tab in Pistol Grip Tool Remote Software window
  5. Enter changes to table as necessary
  6. Select SPEED & POWER MANAGEMENT SETTINGS tab
  7. Enter changes to table as necessary
  8. ✓Ratchet collar – not MTR
  9. Select TOOL, SEND DATA TO TOOL
  10. Select desired tables for upload
  11. ✓All sent settings – black on gray (programmed successfully)
- If saving new settings to a file:
12. Select FILE, SAVE AS ...
  13. Type in new file name, SAVE
  14. Verify programmed settings on PGT by cycling MODE/torque collar/speed collar; compare displayed values to expected values

## DOWNLOAD/ERASE EVENT LOG

1. Perform PGSC-PGT CONNECTION (A31P AND 760XD)
2. ✓Ratchet collar – not MTR
  3. Select EVENT LOG tab
  4. Select TOOL, GET DATA FROM TOOL...
  5. Select TOOL EVENT LOG DATA (READ-ONLY)
  6. ✓DOWNLOAD PGT EVENT LOG dialog box appears
  7. Select YES to download data
  8. ✓SAVE EVENT LOG DATA TO FILE dialog box appears
  9. Enter name for file
  10. Select SAVE
  11. ✓Event Log data displayed in viewer
  12. If erasing Event Log data from PGT, select OK in ERASE EVENT LOG dialog box

## PGT CONTINGENCIES

MESSAGE	CORRECTIVE ACTIONS
BATTERY HITEMP	If alternate battery avail: power off, change battery. Otherwise, power off, switch to Ratchet mode.
BATTERY LOTEMP (blinking)	Drive tool with no load to increase battery temperature. If no joy and alternate battery avail: power off, change battery. Otherwise, power off, switch to Ratchet mode.
BATTERY LOVOLT (blinking)	Continue using until tool is unable to deliver sufficient torque. If no joy and alternate battery avail: Power off, change battery. Otherwise, power off, switch to Ratchet mode.
CAL FAILED	Press, release trigger to repeat calibration. If no joy, power cycle, calibrate. If no joy, power off, switch to Ratchet mode.
COLLAR ERROR	Cycle Torque and Speed collars to clear error. If no joy, power cycle, calibrate. If no joy, power off, switch to Ratchet mode.
COMPAR ERROR	Cycle Torque collar and A/B mode switch. If no joy, power cycle, calibrate. If no joy, power off, switch to Ratchet mode.
EEPROM WR ERR (blinking)	Power cycle, calibrate. If no joy, power off, switch to Ratchet mode.
HI TORQ	If fault occurs during engagement and MTL did not slip, ignore message. Otherwise: power cycle, calibrate. If no joy, power off, switch to Ratchet mode.
HICURR	Reattempt operation. If no joy, power cycle, calibrate. If no joy, power off, switch to Ratchet mode.
HYBRID HITEMP	Power cycle, calibrate. If no joy, power off, switch to Ratchet mode.
LO TORQ	Reattempt operation until desired torque is reached. If no joy, power cycle, calibrate. If no joy, power off, switch to Ratchet mode.
LOCURR	Reattempt operation. If no joy, power cycle, calibrate. If no joy, power off, switch to Ratchet mode.
LOG IS FULL (blinking)	Continue operation.
MOTOR HITEMP	Power off, switch to Ratchet mode.
OVER CURR	Power cycle, calibrate. If no joy, power off, switch to Ratchet mode.
SLFTST FAIL X	Power cycle, calibrate. If no joy, power off, switch to Ratchet mode.

# PGT STANDARD SETTINGS

I

SETTINGS	TORQUE SETPOINT (FT-LB)	TORQUE WINDOW (FT-LB)	TORQUE THRESHOLD (FT-LB)	TURNS
A1	2.5	± 1.0	1.0	--
A2	3.8	± 1.0	1.0	--
A3	4.8	± 1.0	1.0	--
A4	6.3	± 1.0	1.0	--
A5	7.0	± 1.0	1.0	--
A6	8.3	± 1.0	1.0	--
A7	9.2	± 1.0	1.0	--
B1	12.0	± 1.0	1.0	--
B2	16.0	± 1.2	1.0	--
B3	18.4	± 1.7	1.0	--
B4	19.4	± 1.9	1.0	--
B5	22.0	± 2.0	1.0	--
B6	24.0	± 2.0	1.0	--
B7	25.5	± 2.0	1.0	--

SETTINGS	CCW1	CCW2	CCW3	CW3	CW2	CW1
SPEED (RPM)	10	30	60	60	30	10

SLEEP TIME	15 min
AUTO – OFF TIME	30 min

MULTI-SETTING TORQUE LIMITER (MTL) SETTINGS
2.5
5.5
10.5
15.5
23.5
30.5

This Page Intentionally Blank

POST EVA

POST EVA .....	9-2	
SUIT DOFFING .....	9-2	
SAFER DOFFING .....	9-2	
EMU WATER RECHARGE .....	9-3	
SAFER STOW .....	9-3	
SUIT DRYING/SEAL WIPE .....	9-4	
OXYGEN RECHARGE VERIFICATION .....	9-4	
WATER FILL VERIFICATION .....	9-4	
EMU POWERDOWN/OVERNIGHT STOW .....	9-5	

**POST EVA** (00:45 if NOT performing 'If reqd' proc blocks)  
 (01:25 if performing all 'If reqd' proc blocks)

SUIT DOFFING

**WARNING**  
 Do not doff EMU if DCS symptoms resolved during REPRESS. √MCC via PMC

- |          |  |  |
|----------|--|--|
| IV       | <input type="checkbox"/> <input type="checkbox"/> <input type="checkbox"/> | 1. When $\Delta P < 0.5$ , open hatch  |
| MD(flir) | <input type="checkbox"/> <input type="checkbox"/> <input type="checkbox"/> | 2. As reqd, remove diffuser cap at middeck floor, stow                               |
|          | <input type="checkbox"/> <input type="checkbox"/> <input type="checkbox"/> | 3. As reqd, unstow airlock vent duct, connect end to middeck floor fitting           |
| A/L      | <input type="checkbox"/> <input type="checkbox"/> <input type="checkbox"/> | 4. Configure appropriate vent ducts for airflow into airlock                         |
|          | <input type="checkbox"/> <input type="checkbox"/> <input type="checkbox"/> | 5. As reqd, perform BOOSTER FAN INSTALLATION/ACTIVATION<br>( <u>AIRLOCK CONFIG</u> ) |
| EV       | <input type="checkbox"/> <input type="checkbox"/> <input type="checkbox"/> | 6. √Gloves clean   |

\* If reqd, IV use damp towel to clean gloves \*

- |       |     |  |   |
|-------|-----|--|---|
| BOTH  | DCM | <input type="checkbox"/> <input type="checkbox"/> <input type="checkbox"/> | 7. O2 ACT – OFF   |
|       |     | <input type="checkbox"/> <input type="checkbox"/> <input type="checkbox"/> | 8. PURGE vlv – op (up)  |
| IV    | DCM | <input type="checkbox"/> <input type="checkbox"/> <input type="checkbox"/> | 9. Install WATER sw guards (two)  |
|       |     |  | If EMU TV:  |
|       |     | <input type="checkbox"/> <input type="checkbox"/> <input type="checkbox"/> | 10. EMU TV power pb – press; √Green LED not illuminated   |
|       |     |  | If REBA battery:  |
|       |     | <input type="checkbox"/> <input type="checkbox"/> <input type="checkbox"/> | 11. √Glove heaters sw (one per glove) – OFF   |
| PLSS  |     | <input type="checkbox"/> <input type="checkbox"/> <input type="checkbox"/> | 12. REBA sw – OFF (toward left arm of suit)   |
|       |     | <input type="checkbox"/> <input type="checkbox"/> <input type="checkbox"/> | 13. Disconnect lower arm pwr harness from gloves  |
|       |     | <input type="checkbox"/> <input type="checkbox"/> <input type="checkbox"/> | 14. Stow lower arm and glove pwr harness connectors under TMG   |
|       |     |  | If EMU TV:  |
| PLSS  |     | <input type="checkbox"/> <input type="checkbox"/> <input type="checkbox"/> | 15. Demate EMU TV power cable, mate to ground plug  |
| DCM   |     | <input type="checkbox"/> <input type="checkbox"/> <input type="checkbox"/> | 16. √STATUS: <span style="border: 1px solid black; padding: 2px;">SUIT P</span> < 0.4 (compare w/gauge); disconnect gloves, stow in EMU Equipment Bag |
|       |     | <input type="checkbox"/> <input type="checkbox"/> <input type="checkbox"/> | 17. Disconnect helmet, stow   |
| AW82B |     | <input type="checkbox"/> <input type="checkbox"/> <input type="checkbox"/> | 18. AIRLK DEPRESS vlv – install cap   |

POST EVA

- SAFER DOFFING (10 min) (If reqd)
- |    |  |  |
|----|--|--|
| IV | <input type="checkbox"/> <input type="checkbox"/> <input type="checkbox"/> | 19. Remove SAFER latch guard from SAFER latch (leave lanyard strap attached to thruster tower) |
|    | <input type="checkbox"/> <input type="checkbox"/> <input type="checkbox"/> | 20. Latch – ENG  |
|    | <input type="checkbox"/> <input type="checkbox"/> <input type="checkbox"/> | 21. Rotate latch ccw until release (~90 deg)   |
|    | <input type="checkbox"/> <input type="checkbox"/> <input type="checkbox"/> | 22. Demate PLSS from thruster towers   |
|    | <input type="checkbox"/> <input type="checkbox"/> <input type="checkbox"/> | 23. Fold thruster towers   |
|    | <input type="checkbox"/> <input type="checkbox"/> <input type="checkbox"/> | 24. Transfer to middeck  |
| PM | <input type="checkbox"/> <input type="checkbox"/> <input type="checkbox"/> | 25. Install inhibitor (not reqd if SAFER has been used)  |
|    | <input type="checkbox"/> <input type="checkbox"/> <input type="checkbox"/> | 26. Temp stow SAFER  |
|    | <input type="checkbox"/> <input type="checkbox"/> <input type="checkbox"/> | 27. Repeat for SAFER 2   |

Cont next page

- PLSS  28. If reqd, unstow REBA jumper cable  
 29. AAP release handles to 90°
- BOTH  30. Engage HUT in AAP (IV assist as reqd)  
 31. AAP release handles to lock
- DCM  32. FAN – OFF (fwd)  
 33. COMM mode – OFF  
 34. Doff comm cap  
 35. Disconnect waist ring, LCVG, biomed  
 36. √Wrist disconnects – op  
 37. Doff EV glasses  
 38. Doff HUT  
 39. Doff LTA, secure to handrail  
 40. Remove dosimeter from LCVG; insert in inflight garment  
 41. Doff: Biomed (disc OBS/EVA cable, stow in EMU Servicing Kit)  
LCVG (secure to HUT)  
TCU (allow to dry, as reqd)  
MAG, stow in wet trash
- HUT  42. Install Multiple Water Connector cover  
 43. Perform EVA COMM DECONFIG (EVA PREP)
- IV R1  44. O2 TK3 HTR A(B) – as reqd  
ML86B:C  45. cb MNC EXT ARLK HTR LINE ZN 1,2 (two) – cl

EMU WATER RECHARGE (5 min) (If reqd)

R11L  46. SPLY H2O TKA OUTLET – CL (tb-CL)  
 SM 60 TABLE MAINT

CRT  47. Use TKB quantity:  
PARAM ID – ITEM 1 +0 6 2 0 4 2 0 EXEC

48. Log value before recharge

Recharge #	H2O TKB %
1	
2	
3	
4	
5	

AW82D  49. √EMU 1,2 H2O WASTE tb (two) – CL  
SPLY (two) – OP (tb-OP)

CRT  50. √H2O TKB quantity decreasing

SAFER STOW (10 min) (If reqd)

PM  51. √Inhibitor installed  
 52. Latch – PRELOAD  
 53. Rotate latch cw until lock markings on latch and tower  
recess aligned

54. Push in latch, latch – LCK  
 55. Install latch guards over latches under TMG, and reattach TMG  
 56. Fold thruster towers  
 57. Unstow stowage straps from EMU Equipment Bag; install

PM  58. MAN ISOL vlv – CL (up)  
 59. Stow SAFER in Stowage Bag  
 60. Repeat for SAFER 2

Cont next page

SUIT DRYING/SEAL WIPE

- 61. Wipe with drying towel:  
LTA, legs, boots  
HUT, suit arms  
Gloves
- 62. Inspect Gloves for damage  
Report damage to MCC

**WARNING**  
Avoid stericide contact with eyes. Wash hands thoroughly after application

- 63. Wipe LTA crotch and HUT armpit areas with stericide (in EMU Servicing Kit)
- 64. Lightly wipe seals on LTA waist ring, arm wrist rings, HUT neck ring with lint-free wipe (in EMU Servicing Kit)
- 65. Clean, refurbish biomed
- 66. Remove drink bag from HUT and dispose in wet trash
- 67. ✓ Drink Bag Restraint Bag installed in HUT

OXYGEN RECHARGE VERIFICATION

DCM    68. ✓ STATUS: O2 P ~850 (recharge complete)

WATER FILL VERIFICATION (10 min) (If reqd)

DCM    69. ✓ STATUS: H2O WP 8-15 psi and stable for ~30 sec  
(indicates charging complete)

SM 60 TABLE MAINT

- CRT    70. Use TKB quantity:  
PARAM ID – ITEM 1 +0 6 2 0 4 2 0 EXEC
- R11L    71. Log value after recharge

Recharge #	H2O TKB %
1	
2	
3	
4	
5	

NOTE

Full charge = ~6%/EMU

- R11L    72. SPLY H2O TKA OUTLET – OP (tb-OP)
- WCS    73. ✓ FAN SEP same as HOSE BLOCK
- 74. MODE – COMMODE/MANUAL/EMU, posn guard over sw  
(✓airflow, WCS ON It on)
- AW82D    75. EMU 1,2 H2O SPLY (two) – CL (tb-CL)
- 76. Install SCOFs, lock
- DCM    77. O2 ACT – IV
- AW82H    78. EMU 1,2 H2O WASTE reg (two) – MAN OP

NOTE

Step 79 will be performed serially for EMU 1 and EMU 2

- AW82D    79. EMU 1(2) H2O WASTE (one) – OP (tb-OP) (1 min), then  
– CL (tb-CL)  
– Repeat for other EMU
- AW82H    80. EMU 1,2 H2O WASTE reg (two) – REGULATING
- DCM    81. O2 ACT – OFF
- 82. Remove SCOFs, stow
- WCS    83. MODE – AUTO (✓WCS ON It off)



EMU POWERDOWN/OVERNIGHT STOW

- 84. Stow comm cap in right arm of EMU
  - 85. Install helmets and covers
  - AW18D    86. AIRLK AUD PWR – OFF
  - AW18H    87. PWR/BATT CHGR EMU 1,2 BUS SEL (two) – OFF  
PWR/BATT CHGR EMU 1,2 MODE (two) – OFF
  - AW82D    88. √EMU 1,2 H2O WASTE,SPLY tb (four) – CL
  - AW82B    89. EV-1,EV-2 O2 vlv (two) – CL
- If not performing in-suit EMU battery recharge:
- BOTH DCM    90. Remove SCU; install DCM cover
91. Stow SCU on AAP, Velcro to wall
92. Tether LTA to airlock handrail
93. Hang LCVGs, TCUs, and other EMU accessories for drying

If last EVA completed:

- X: SM 60 SM TABLE MAINT
- 94. Contact MCC for uplink of SM ALERT TMBU (if desired)  
Changes enclosed in

<u>Param Name</u>	<u>Param ID</u>	<u>Lower Limit</u>	<u>Upper Limit</u>
EXT A/L H2O LINE T 1			
EXT A/L H2O SPLY ZN 1 T	0640181	43	<input type="checkbox"/> 145
EXT A/L LCG 2 SPLY ZN 1 T	0640182	<input type="checkbox"/> 49	<input type="checkbox"/> 145
EXT A/L H2O LINE T 2			
EXT A/L H2O SPLY ZN 2 T	0640184	48	<input type="checkbox"/> 145
EXT A/L LCG 2 SPLY ZN 2 T	0640185	<input type="checkbox"/> 45	<input type="checkbox"/> 145
EXT A/L O2 LN T			
EXT A/L O2 SPLY ZN 2 T	0640186	OSL	<input type="checkbox"/> OSH

This Page Intentionally Blank

EMU MAINT/RECHARGE

WATER RECHARGE..... 10-2  
    EMU POWERUP..... 10-2  
    WATER FILL ..... 10-2  
    WATER FILL VERIFICATION ..... 10-2  
EMU LiOH CHANGEOUT ..... 10-4  
MIDDECK EMU BATTERY RECHARGE (STAND-ALONE)..... 10-4a  
MIDDECK EMU BATTERY RECHARGE/LiOH REPLACEMENT ..... 10-5  
    INITIATE ..... 10-5  
    TERMINATE..... 10-6  
IN-SUIT EMU BATTERY RECHARGE/CHARGE VERIFICATION..... 10-7  
    INITIATE ..... 10-7  
    TERMINATE..... 10-7  
EMU POWERDOWN ..... 10-7  
HELMET LIGHT/PGT BATTERY RECHARGE ..... 10-8  
    INITIATE ..... 10-8  
    TERMINATE..... 10-9  
REBA BATTERY INSTALLATION ..... 10-9  
EMU BATTERY REMOVAL/INSTALL ..... 10-10  
HELMET LIGHT BULB CHANGEOUT ..... 10-11  
REBA BATTERY RECHARGE ..... 10-12  
    INITIATE ..... 10-12  
    TERMINATE..... 10-13

## WATER RECHARGE

### IF EMU NOT ALREADY POWERED UP:

#### EMU POWERUP

- BOTH DCM 1. Retrieve, position SCUs; remove DCM covers  
 2. Connect SCUs to DCM, √locked  
 3. PWR – BATT

#### CAUTION

EMU must be on BATT pwr when  
 airlock pwr supply is turned on

- AW18H 4. PWR/BATT CHGR EMU 1,2 MODE (two) – PWR  
 BUS SEL (two) – MNA(MNB)  
 MD(flr) 5. √EMU O2 ISOL VLV – OP  
 AW82B 6. EV1,2 O2 vlv (two) – OP  
 DCM 7. PWR – SCU

#### WATER FILL

- MO13Q 8. √ARLK H2O S/O VLV – OPEN (tb-OP)  
 R11L 9. √SPLY H2O TKA OUTLET – CL (tb-CL)

#### SM 60 TABLE MAINT

- CRT 10. Use TKB quantity:  
 PARAM ID – ITEM 1 +0 6 2 0 4 2 0 EXEC  
 11. Log value before recharge

Recharge #	H2O TKB %
1	
2	
3	
4	
5	

- AW82D 12. √EMU 1,2 H2O WASTE tb (two) – CL  
 SPLY (two) – OP (tb-OP)  
 13. √H2O TKB quantity decreasing

#### NOTE

Full charge requires ~15 min

#### WATER FILL VERIFICATION

- DCM 14. √STATUS: H2O WP 8-15 psi and stable for ~30 sec (indicates charging complete)

#### SM 60 TABLE MAINT

- CRT 15. Use TKB quantity:  
 PARAM ID – ITEM 1 +0 6 2 0 4 2 0 EXEC  
 16. Log value after recharge

Recharge #	H2O TKB %
1	
2	
3	
4	
5	

EMU MAINT/  
 RECHARGE

Cont next page

NOTE

Full charge = ~6%/EMU

- R11L 17. SPLY H2O TKA OUTLET – OP (tb-OP)
- WCS 18. √FAN SEP same as HOSE BLOCK
- 19. MODE – COMMODE/MANUAL/EMU, posn guard over sw  
(√airflow, WCS ON It on)
- AW82D 20. EMU 1,2 H2O SPLY (two) – CL (tb-CL)
- 21. Install SCOFs, lock
- DCM 22. O2 ACT – IV
- AW82H 23. EMU 1,2 H2O WASTE reg (two) – MAN OP

NOTE

Step 24 will be performed serially for EMU 1 and EMU 2

- AW82D 24. EMU 1(2) H2O WASTE (one) – OP (tb-OP) (1 min), then  
– CL (tb-CL)  
– Repeat for other EMU
- AW82H 25. EMU 1,2 H2O WASTE reg (two) – REGULATING
- DCM 26. O2 ACT – OFF
- 27. Remove SCOFs, stow
- WCS 28. MODE – AUTO (√WCS ON It off)
- 29. If EMU powerup performed, go to EMU POWERDOWN

## EMU LiOH CHANGEOUT (20 min)

1. Transfer new cartridges to airlock
2. Transfer new batteries, as reqd, to airlock
3. Release EMU from AAP, posn as reqd
4. Unzip thermal cover, Velcro to top of EMU
5. Record used LiOH serial numbers

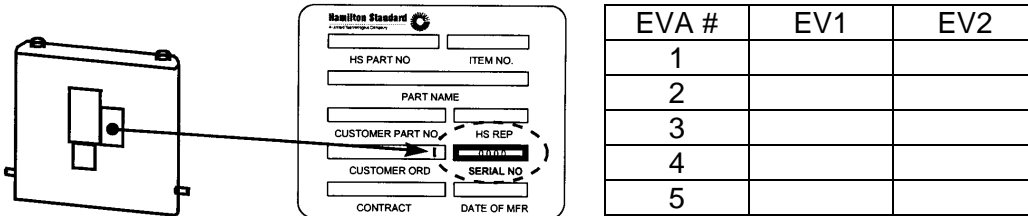

6. Remove, mark used LiOH cartridge

**IF EMU BATTERY TO BE REPLACED:**

AW18H      7. PWR/BATT CHGR EMU 1,2 BUS SEL (two) – OFF  
 DCM        8. ✓PWR – SCU

**CAUTION**

Do not allow battery to impact airlock wall and use care when handling/stowing battery to avoid damaging aluminum cover

9. Remove used battery
10. Install new battery (✓connector alignment), latch

**CAUTION**

If 10.2 cabin used, possible  $\Delta P$  across LiOH cartridge caps. Direct ports away from face

Limit exposure time of uncapped canister ports and avoid contact with seals

11. Holding new LiOH cartridge with aluminum plate serial number facing self, remove caps (left first), ✓O-ring seals for damage, install LiOH (attach Velcro retainer strap)
12. Close thermal cover zipper
13. Reinstall EMU in AAP
14. Place caps on used LiOH cartridge
15. Stow used batteries, LiOH in middeck lockers

## MIDDECK EMU BATTERY RECHARGE (STAND-ALONE)

I

### INITIATE (20 min)

- |         |  |
|---------|--|
|         | 1. Unstow middeck battery charger                              |
| ML85E   | 2. √DC UTIL PWR – OFF on specified utility outlet              |
| (MUP)   | 3. Affix batteries to charger using Velcro straps on charger   |
|         | 4. Connect charger cables to batteries                         |
|         | 5. Stow batteries/charger for charge                           |
|         | 6. Connect charger power cable to specified MUP utility outlet |
|         | 7. √CB closed for specified utility outlet                     |
|         | 8. DC UTIL PWR – ON  |
| Charger | 9. √ON LEDs (red) – ON   |
|         | √READY LEDs (green) – ON (for 10 sec at startup)               |
|         | √READY LEDs (green) – blinking                                 |

### NOTE

EMU batteries may experience a false charge completion due to passivation within the battery. The passivation is removed with repeated attempts (two to three times) at charging the battery

After 15 min charging, verify charging is continuing:

- |         |                                |
|---------|--------------------------------|
| Charger | 10. √ON LEDs (red) – ON        |
|         | √READY LEDs (green) – blinking |

- |         |  |   |
|---------|--|---|
|         | * If ON LED (red) is OFF and READY LED (green) is ON | * |
|         | * (non-blinking):                                    | * |
|         | * 1. DC UTIL PWR – OFF (3 sec)                       | * |
|         | * 2. DC UTIL PWR – ON                                | * |
|         | * 3. √ON LEDs (red) – ON                             | * |
| Charger | * √READY LEDs (green) – ON 10 sec at startup         | * |
|         | * √READY LEDs (green) – blinking                     | * |
|         | * 4. Report anomaly to MCC                           | * |

### NOTE

The absence of any active LEDs represents an over-current or overvoltage condition that has caused the charger to shut down, or the charger has not been properly powered from the DC Utility Outlet. All protective conditions are resettable by taking the DC UTILITY POWER to OFF.

During the charge, the red ON LED will be illuminated and the green READY LED will continue to blink, giving positive indication that the charger is still charging

## MIDDECK EMU BATTERY RECHARGE (STAND-ALONE) (Cont)

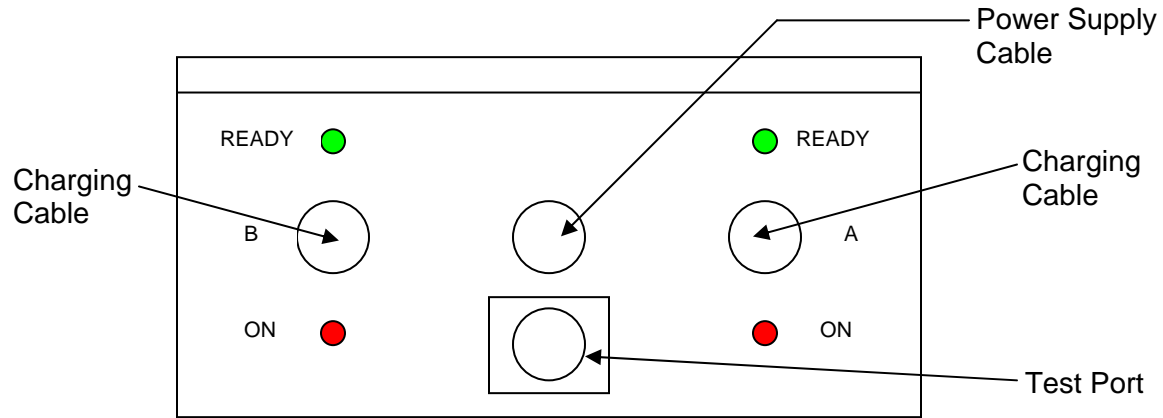

TERMINATE (10 min)

### NOTE

When a nominal charge is complete, the red ON LED will extinguish and the green READY LED will illuminate without blinking. The red ON LED will be illuminated only when the positive current flow into the battery is greater than 0.6A

11. When charge complete:
  - Charger           √ON LEDs (red) – OFF
  - √READY LEDs (green) – ON
  - ML85E           DC UTIL PWR – OFF
  - (MUP)           Disconnect cables from batteries
12. Disconnect charger power cable from utility outlet
13. Stow charger and batteries



# MIDDECK EMU BATTERY RECHARGE/LiOH REPLACEMENT

INITIATE (30 min)

## NOTE

Refer to REF DATA for specific plug-in location

1. Unstow new LiOH cartridges
2. Unzip thermal cover, Velcro to top of EMU
3. Record used LiOH serial numbers

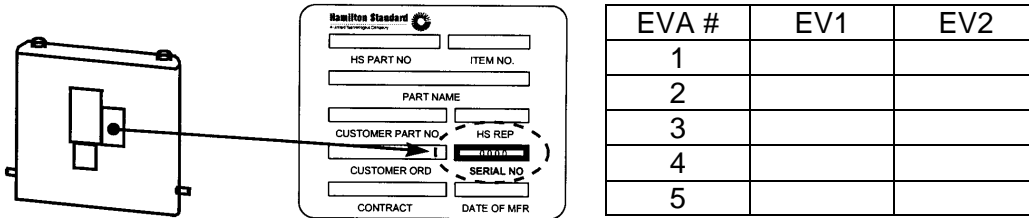

- DCM
4. Remove, mark, stow used LiOH cartridge
  5. ✓PWR – SCU

## CAUTION

Do not allow battery to impact airlock wall and use care when handling/stowing battery to avoid damaging aluminum cover

6. Remove, stow used battery

## CAUTION

If 10.2 cabin used, possible  $\Delta P$  across LiOH cartridge caps. Direct ports away from face  
Limit exposure time of uncapped canister ports and avoid contact with seals

7. Holding new LiOH cartridge with aluminum plate serial number facing self, remove caps (left first), ✓O-ring seals for damage, install LiOH (attach Velcro retainer strap)
8. Close thermal cover zipper, stow EMU in middeck
9. Unstow middeck battery charger
- \_\_\_\_\_ 10. ✓DC UTIL PWR – OFF
11. Configure battery(s), charger, and straps for charge
12. Connect charger cable(s) to battery(s)
13. Stow battery(s)/charger for charge
14. Connect power cable to utility outlet
- \_\_\_\_\_ 15. DC UTIL PWR – ON
- Charger 16. ✓ON LEDs (red) – ON  
✓READY LEDs (green) – ON (for 10 sec at startup)  
✓READY LEDs (green) – blinking

## NOTE

EMU batteries may experience a false charge completion due to passivation within the battery. The passivation is removed with repeated attempts (two to three times) at charging the battery

After 15 min charging, verify charging is continuing:

- Charger
17. ✓ON LEDs (red) – ON  
✓READY LEDs (green) – blinking

- \* If ON LED (red) is OFF and READY LED (green) is ON \*
- \* (non-blinking): \*
- \* 18. DC UTIL PWR – OFF (3 sec) \*
- \* 19. DC UTIL PWR – ON \*
- \* Charger 20. √ON LEDs (red) – ON \*
- \* √READY LEDs (green) – ON 10 sec\* \*
- \* at startup \*
- \* √READY LEDs (green) – blinking \*
- \* 21. Report anomaly to MCC \*

**NOTE**

The absence of any active LEDs represents an over-current or overvoltage condition that has caused the charger to shut down, or the charger has not been properly powered from the DC Utility Outlet. All protective conditions are resettable by taking the DC UTILITY POWER to OFF.

During the charge, the red ON LED will be illuminated and the green READY LED will continue to blink, giving positive indication that the charger is still charging

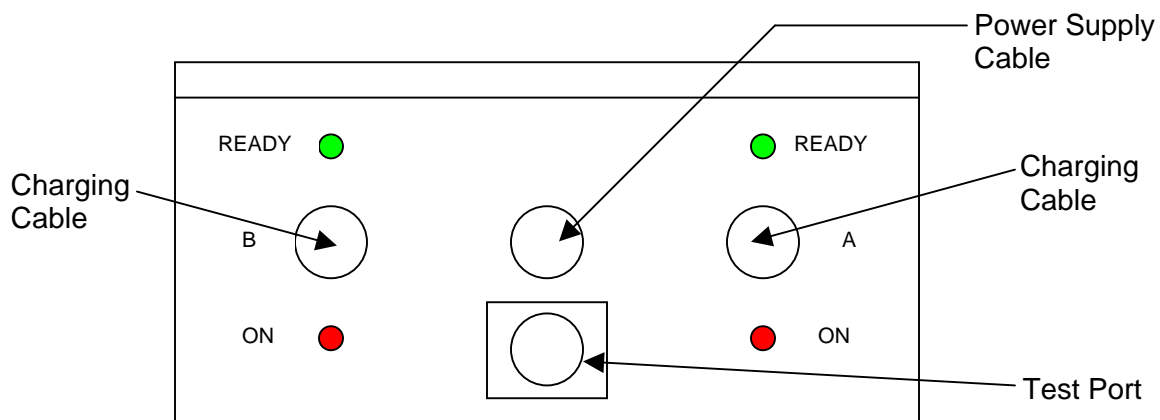

**TERMINATE** (15 min)

**NOTE**

When a nominal charge is complete, the red ON LED will extinguish and the green READY LED will illuminate without blinking. The red ON LED will be illuminated only when the positive current flow into the battery is greater than 0.6A

- Charger 22. When charge complete:
  - √ON LEDs (red) – OFF
  - √READY LEDs (green) – ON
  - DC UTIL PWR – OFF
  - Disconnect cable(s) from battery(s)
- 23. Unzip thermal cover, Velcro to top of EMU
- 24. Remove LiOH cartridge
- 25. Open battery latch
- 26. Install charged battery (√connector alignment); latch
- 27. Reinstall LiOH (attach Velcro retainer strap)
- 28. Close thermal cover zipper

## IN-SUIT EMU BATTERY RECHARGE/CHARGE VERIFICATION

### INITIATE

1. Retrieve, position SCUs; remove DCM covers
2. Connect SCUs to DCM, √locked
- AW18H 3. PWR/BATT CHGR EMU 1,2 BUS SEL (two) – OFF  
MODE (two) – CHARGE  
BUS SEL (two) – MNA(MNB)
4. Continue charge as reqd:  
Verification: 15 min, minimum  
Full Charge: Up to 20 hr

### TERMINATE

- AW18H 5. √PWR/BATT CHGR EMU INPUT AMPS < 1 for both EMUs
6. PWR/BATT CHGR EMU 1,2 BUS SEL (two) – OFF  
MODE (two) – OFF
7. Remove SCU, install DCM cover
8. Stow SCU on AAP, Velcro to wall

## EMU POWERDOWN

- AW18H 1. PWR/BATT CHGR EMU 1,2 BUS SEL (two) – OFF  
MODE (two) – OFF
- AW82D 2. √EMU 1,2 H2O WASTE,SPLY tb (four) – CL
3. Remove SCU, install DCM cover
4. Stow SCU on AAP, Velcro to wall

# HELMET LIGHT/PGT BATTERY RECHARGE

INITIATE (10 min)

## NOTE

Refer to REF DATA for specific plug-in location

1. Unstow, as reqd: EHIP Light Battery Charger  
EHIP DC PWR/REBA DC EXT Y-Cable  
EHIP-PGT Adapter cable (charger to battery) (2)  
PGT Batteries (2)  
Helmet Light Batteries (4)
2. ✓DC UTIL PWR – OFF
3. Plug EHIP DC PWR/REBA DC EXT Y-Cable into charger, then into orbiter pwr supply
4. DC UTIL PWR – ON  
✓Blue LEDs illuminated
  - \* If blue LEDs not illuminated: \*
  - \* ✓DC UTIL PWR – ON \*
  - \* If blue LEDs still not illuminated: \*
  - \* DC UTIL PWR – OFF \*
  - \* Unplug EHIP DC PWR/REBA DC EXT Y-Cable \*
  - \* from charger \*
  - \* Change fuse (7.5A) \*
  - \* Plug EHIP DC PWR/REBA DC EXT Y-Cable \*
  - \* into charger \*
  - \* DC UTIL PWR – ON \*

IFM Pin Kit

If charging helmet light batteries:

5. Install batteries (four) into charger

If charging PGT batteries, for EACH battery:

6. Release captive screw on PGT battery door using screwdriver
7. Pry open PGT battery door, rotate away from cavity
8. Remove cap from EHIP PGT Adapter cable into charger
9. Remove battery jumper, temp stow on EHIP-PGT Adapter cable cap  
Plug EHIP-PGT Adapter cable into battery
10. Install EHIP-PGT Adapter cable into charger
11. ✓Yellow LED illuminated; start timer (MET \_\_\_\_/\_\_\_\_:\_\_\_\_:\_\_\_\_);  
temp stow charger

\* If yellow LED not illuminated, see chart below \*

Indicator	Problem	Solution
Green and red LED illuminated	Cold batt (≤ 50 degF)	Leave batt installed in charger (batt will warm up and automatically change LED to yellow)
Red LED illuminated	Hot batt (≥ 113 degF)	DC UTIL PWR – OFF Remove batt or EHIP-PGT adapter if PGT batt DC UTIL PWR – ON

12. Wait 15 min and check LEDs

If yellow LEDs illuminated:

13. Continue charging

If green LED(s) illuminated:

14. DC UTIL PWR – OFF
15. Remove battery or EHIP-PGT Adapter cable from affected station(s)
16. DC UTIL PWR – ON
17. Wait for blue LED(s) to illuminate
18. Re-install battery or EHIP-PGT Adapter cable
19. ✓Yellow LED(s) illuminated
20. Continue charging

Cont next page

TERMINATE (10 min)

NOTE

Refer to REF DATA for specific plug-in location

1. ✓Green LED illuminated

WARNING

Ensure charger is unpowered before disconnecting batteries

CAUTION

Do not leave batteries installed after unpowering charger to prevent possible charger damage and battery discharge

2. DC UTIL PWR – OFF

If helmet light batteries charged:

3. Remove batteries from charger
4. Install batteries in lights
5. ✓EMU light ops

CAUTION

Do not stow EMU lights in locker with batteries installed

If PGT batteries charged, for each battery:

6. Remove EHIP-PGT Adapter cable from charger
7. Unplug battery from EHIP-PGT Adapter cable; reinstall cap on cable

NOTE

PGT battery will not function if jumper is not installed

8. Re-install battery jumper
9. Rotate battery door into place, tighten screw using screwdriver
10. Mark batteries “charged”, stow in locker
11. Stow as reqd:
  - EHIP Light Battery Charger(s)
  - EHIP DC PWR/REBA DC EXT Y-Cable
  - EHIP-PGT Adapter cables (2)
  - PGT Batteries (2)

**REBA BATTERY INSTALLATION**

1. Unstow REBA from locker or charger
2. Remove EMU from AAP, unzip TMG to access REBA pouch and EMU power harness
3. ✓Glove heater sw (two) – OFF
4. Remove REBA J1 fabric cover
5. Install REBA on EMU
6. Route REBA sw pull tabs thru TMG loops
7. ✓REBA sw (one per EMU) – OFF (toward left arm of suit)
8. Connect EMU power harness (P1) to REBA (J1); verify locked by gently pulling on EMU power harness cable
9. Zip TMG closed, install EMU on AAP

## EMU BATTERY REMOVAL/INSTALL (5 min)

### CAUTION

Do not allow battery to impact airlock wall and use care when handling/stowing battery to avoid damaging aluminum cover

### WARNING

EMU pwr switch must be in SCU position with airlock pwr OFF during battery changeout

DCM

1. √PWR – SCU

If SCU connected to DCM:

AW18H

2. √PWR/BATT CHGR EMU 1,2 BUS SEL (two) – OFF

PLSS

3. Release EMU from AAP as reqd
4. Unzip thermal cover, Velcro to top of EMU
5. Open LiOH(Metox) latches
6. Rotate LiOH(Metox) canister outward until softstop or remove canister
7. Open battery latches
8. Remove/install EMU battery as reqd (√connector alignment)
9. Close battery latches
10. Reinstall LiOH(Metox), latch
11. Close thermal cover
12. Reinstall EMU in AAP as reqd
13. Stow or charge batteries as reqd

## HELMET LIGHT BULB CHANGEOUT (15 min)

### NOTE

Light assembly has several loose pieces which may be spring loaded. Be prepared to capture them during changeout

### CAUTION

Handle bulbs with care. Do not touch bulbs with bare hands (could degrade bulb life span)

1. Remove battery from affected side of lights
2. If EMU TV installed, remove camera from affected side of lights
3. Obtain, don comfort glove
4. Depress faceplate; open faceplate sliders (two) on affected side of lights
5. Remove faceplate
6. Remove reflector housing by pulling straight out
7. Remove affected bulbs as reqd, replace
8. Mark, stow used bulbs

### NOTE

Contacts on spot bulb may be difficult to reseal fully into socket

9. Install reflector housing and flood bulb reflector, seat spot bulb
10. Install faceplate, lock sliders (two)
11. Install battery; ✓EMU light ops
12. If EMU TV installed, attach camera back to affected side of lights
13. Remove, stow comfort glove

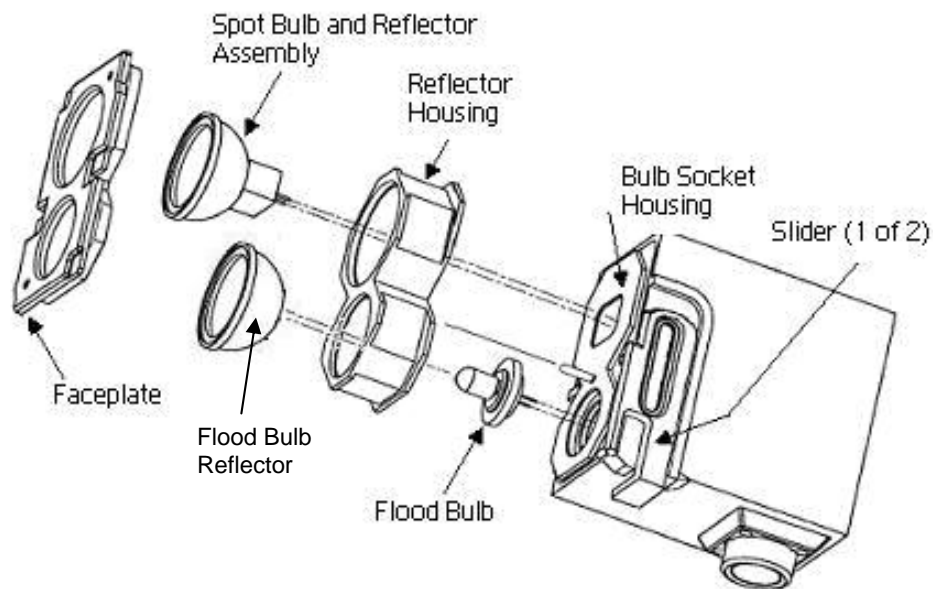

# REBA BATTERY RECHARGE

INITIATE (10 min)

## NOTE

Refer to REF DATA for specific plug-in plan location

1. Unstow: REBA Charger  
EHIP DC PWR/REBA DC EXT Y-Cable  
25' REBA/EHIP Ext Pwr cable (if reqd)
2. ✓DC UTIL PWR – OFF  
If in-suit recharge:
  3. Plug EHIP DC PWR/REBA DC EXT Y-Cable into charger, 25' REBA/EHIP Ext Pwr cable into EHIP DC PWR/REBA DC EXT Y-Cable, 25' REBA/EHIP Ext Pwr cable into orbiter power supply
 Else:
  4. Plug EHIP DC PWR/REBA DC EXT Y-Cable into charger and orbiter power supply
5. DC UTIL PWR – ON  
✓Blue LEDs (two) illuminated
  - \* If blue LED not illuminated: \*
  - \* ✓DC UTIL PWR – ON \*
  - \* ✓cb – cl \*
  - \* ✓Cable connections mated \*
  - \* If blue LED still not illuminated: \*
  - \* DC UTIL PWR – OFF \*
  - \* Unplug EHIP DC PWR/REBA DC EXT Y-Cable from charger \*
  - \* Change fuse (4.0 Amps) \*
  - \* Plug EHIP DC PWR/REBA DC EXT Y-Cable into charger \*
  - \* DC UTIL PWR – ON \*
6. ✓REBA sw (two) – OFF
7. Demate REBA jumper cables (two)
8. Mate charger cables (two) to REBA jumper cables
9. ✓Yellow LEDs (two) illuminated; temp stow charger on wall

\* If yellow LED not illuminated, see chart below \*

Indicator	Problem	Solution
Green and red LED illuminated	Cold batt (≤ 50 degF)	Leave REBA connected to charger (REBA will warm up and automatically change LED to yellow)
Red LED illuminated	Hot batt (≥ 113 degF)	DC UTIL PWR – OFF Disconnect REBA from charger. Allow REBA to cool DC UTIL PWR – ON Mate charger cable to REBA jumper cable

When 15 min of charge complete:

10. ✓READY LEDs (green) – Off
  - \* If READY LED (green) – On: \*
  - \* DC UTIL PWR – OFF \*
  - \* Disconnect REBA from charger \*
  - \* DC UTIL PWR – ON \*
  - \* When NO BATTERY LED (blue) – On: \*
  - \* Mate charger cable to REBA jumper cable \*
  - \* ✓CHARGING LED (yellow) – On \*



TERMINATE (10 min)

NOTE

Refer to REF DATA for specific plug-in plan location

1. ✓Green LED illuminated

WARNING

Ensure charger is unpowered before disconnecting batteries

CAUTION

Do not leave batteries installed after unpowering charger to prevent possible charger damage and battery discharge

2. DC UTIL PWR – OFF
3. Disconnect REBA from charger
4. Mate REBA jumper cables
5. Stow: REBA Charger  
EHIP DC PWR/REBA DC EXT Y-Cable  
25' REBA/EHIP Ext Pwr cable (if reqd)

This Page Intentionally Blank

POST EVA ENTRY PREP

**POST EVA ENTRY PREP** (45 min if SAFER not flown)  
(55 min if SAFER flown)

POST EVA  
ENTRY PREP

- AW18D 1. AIRLK AUD PWR – OFF
- AW18H 2. PWR/BATT CHGR EMU 1,2 BUS SEL (two) – OFF  
MODE (two) – OFF
- MD(flr) 3. EMU O2 ISOL VLV – CL
- AW82B 4. EV-1, EV-2 O2 vlv (two) – CL
- AW82D 5. √EMU 1,2 H2O WASTE, SPLY tb (four) – CL
- 6. Stow in FDF locker: DEPRESS/REPRESS (Cue Card)  
Cuff C/L (two)
- 7. Disconnect comm caps (two) from elec harness, temp stow
- 8. Remove LTA, √Multiple Water Connector cover installed
- 9. Stow LCVG and EV Crew Options Kit (ECOK) in HUT
- 10. Connect LTA to HUT
- 11. Install gloves
- 12. √Any wrist tethers attached to glove tether loop with only one hook (other hook on D-ring or first hook) and cinched down around wrist
- If REBA:
- 13. Remove REBA batteries from all EMUs, stow

**CAUTION**  
EMU TV and helmet lights must be removed prior to landing

- If EMU TV:
- 14. Remove EMU TVs from helmet lights, stow
- 15. Transfer EMU lights to middeck
- 16. Install helmets and covers, lock
- 17. Remove SCU, install DCM cover
- DCM 18. Stow SCU on AAP, rebuckle straps
- 19. √PURGE vlv – op (up)
- 20. Perform LTA RESTRAINT STRAP INSTALLATION (AIRLOCK CONFIG)  
as reqd for landing configuration
- 21. Attach LTA Restraint Bags over LTA, suit arms; tighten straps
- 22. Stow comm caps in LTA Restraint Bag pouch
- 23. Install and loosely secure airlock floor pallet using 1/4-in drive ratchet, 4-in ext w/1/4-in drive, and 1/2-in socket w/1/4-in drive. Torque to 200 in-lb using torque wrench

SAFER ENTRY STOW (10 min) (if reqd)

- 24. Deploy HCM
- 25. Install pwr sw guard
- 26. Stow HCM in foam outside of SAFER
- 27. Stow SAFER in stowage bag

- 28. Install additional EMU(s)/Airlock Stowage Bag(s) in airlock; √bag, strap installed
- 29. Install 20-g Crash Bag on middeck EMUs (if flown)
- 30. Remove batteries from lights, stow in lockers

**CAUTION**  
To prevent possible equipment damage, do not stow EMU lights in locker with batts installed

- Vol H 31. Stow EMU lights, EMU Equipment Bag, EVA Bag in middeck
- Inner Hatch 32. Equal vlv (two) – NORM, install caps
- \* If outer hatch leaking or integrity suspect: \*
- \* Equal vlv (two) – OFF, install caps \*
- 33. Inform MCC, Post EVA Entry Prep complete

**POST ISS EVA ENTRY PREP (45 min if SAFER not flown)  
(55 min if SAFER flown)**

- MD(flir) 1. EMU O2 ISOL VLV – CL
- AW18D 2. AIRLK AUD PWR – OFF
- AW18H 3. √PWR/BATT CHGR EMU 1,2 BUS SEL (two) – OFF  
MODE (two) – OFF
- AW82B 4. √EV-1, EV-2 O2 vlv (two) – CL
- AW82D 5. √EMU 1,2 H2O WASTE, SPLY tb (four) – CL
- 6. √No helmet lights or EMU TV installed on helmets
- 7. Remove helmets, temp stow
- 8. Disconnect comm caps from EMU electrical harness, temp stow
- 9. Remove LTA, √Multiple Water Connector cover installed
- 10. √Only LCVG and EV Crew Options Kit (ECOK) in HUT
- 11. Connect LTA to HUT
- 12. √Gloves installed, locked
- 13. √Any wrist tethers attached to glove tether loop with only one hook (other hook on D-ring or first hook) and cinched down around wrist
- 14. Install helmets, lock
- 15. Install helmet covers if not already installed
- 16. √SCU stowed on AAP, straps buckled
- DCM 17. √PURGE vlvs – op (up)
- Vol H 18. √No loose items temp stowed in Vol H (waist tethers, etc). Install as reqd
- 19. Attach LTA Restraint Bags over LTA, suit arms, tethers; tighten straps
- 20. Stow comm caps in LTA Restraint Bag pocket
- If airlock floor pallet removed:
  - 21. Install and loosely secure airlock floor pallet using 1/4–in drive ratchet, 4–in ext w/1/4–in drive, and 1/2–in socket w/1/4–in drive. Torque to 200 in–lb using torque wrench
  - 22. Install floor Airlock Stowage Bag in airlock; √bag, strap installed
  - 23. Install 20-g Crash Bag on middeck EMUs (if flown)

**SAFER ENTRY STOW (10 min) (If SAFER returning)**  
 24. Deploy HCM  
 25. Install power switch guard ('PWR' over PWR switch)  
 26. Stow HCM in foam outside of SAFER  
 27. Stow SAFER in stowage bag

- Inner Hatch 28. Equal vlv (two) – NORM, install caps
  - \* If outer hatch leaking or integrity suspect: \*
  - \* Equal vlv (two) – OFF, install caps \*
- 29. Inform MCC, Post ISS EVA Entry Prep complete
- 30. Stow in FDF/ODF locker (if reqd):
  - FDF EVA Checklist
  - Used EVA Prebreathe Cue Card
  - ISS EVA Systems Checklist

This Page Intentionally Blank

OFF-NOMINAL PROCEDURES

----- OFF-NOMINAL PROCS -----

This Page Intentionally Blank



EMU CONTINGENCY PROCS

DISPLAY LOSS DURING POWER TRANSFER (WARM RESTART) .....	12-2
VACUUM H2O RECHARGE (MANNED) .....	12-2
LiOH REPLACEMENT (MANNED) .....	12-3
BATTERY REPLACEMENT (MANNED) .....	12-4
WATER DUMP .....	12-6
SCU SWAP (UNMANNED) .....	12-7
(MANNED) .....	12-7
EMU COLD RESTART (MANNED) .....	12-7
12.1 STS EVA DECONTAMINATION .....	12-8
CONTAMINATION TEST .....	12-15
SAFER BATTERY CHANGEOUT .....	12-18
BENDS TREATMENT ADAPTER (BTA) INSTALLATION (IN-SUIT) .....	12-19
BTA PREP .....	12-19
TREATMENT .....	12-19
BENDS TREATMENT ADAPTER (BTA) INSTALLATION (POST SUIT DOFFING) .....	12-21
BTA PREP .....	12-21
TREATMENT .....	12-21
EMU RESIZE .....	12-24

**EMU CONT  
PROCS**

## DISPLAY LOSS DURING POWER TRANSFER (WARM RESTART)

- DCM If PWR – BATT and SCU connected:  
 AW18H 1. √PWR/BATT CHGR EMU 1(2) BUS SEL – OFF  
 DCM If PWR – SCU:  
 2. PWR – BATT  
 AW18H 3. PWR/BATT CHGR EMU 1(2) BUS SEL – OFF

**WARNING**  
 Fan will be off from steps 4 to 9 during  
 which time CO2 buildup is a concern

NOTE

Affected EMU will be without comm after step 6. Steps 6 and 7 should be read together before step 6 is performed

- DCM 4. FAN – OFF (expect FAN SW OFF msg, DISP – PRO) |  
 IV 5. Inform affected EV crewmember of impending comm loss  
 DCM 6. PWR – SCU (7 sec)  
 7. PWR – BATT  
 When power restart complete:  
 8. √Display – O2 POS XX, expect FAN SW OFF msg, DISP – PRO |  
 9. As reqd, FAN – ON  
 If display blank or locked up:  
 10. Contact MCC  
 If SCU power desired:  
 11. √SCU connected to DCM  
 AW18H 12. PWR/BATT CHGR EMU 1(2) MODE – PWR  
 BUS SEL – MNA(MNB)  
 13. √EMU INPUT 1(2) Volts = 18.0 – 20.0  
 DCM 14. PWR – SCU  
 DCM 15. √Display – O2 POS XX

## VACUUM H2O RECHARGE (MANNED)

**WARNING**  
 Procedure should be used only if performing a contingency EVA

- EV 1. Perform AIRLOCK INGRESS, Cuff C/L, 30 (Close hatch, partially engage latches)  
 2. √Helmet purge vlv – cl, locked  
 DCM 3. √PURGE vlv – cl (dn)  
 4. √WATER – OFF  
 IV MO13Q 5. √ARLK H2O S/O VLV – OPEN (tb-OP)  
 MD(flr) 6. √EMU O2 ISOL VLV – OP  
 ML86B:C 7. √cb MNC EXT ARLK HTR LINE ZN 1,2 (two) – op  
 AW82B 8. √EV-1(EV-2) O2 vlv – OP  
 EV AW18H 9. PWR/BATT CHGR EMU 1(2) BUS SEL – MNA(MNB)  
 DCM 10. PWR – SCU (fwd), WARN TONE  
 IV R11L If SPLY H2O XOVR VLV closed (tb-CL or bp) (water transfer config):  
 | 11. SPLY H2O TKA OUTLET – CL (tb-CL)  
 If SPLY H2O XOVR VLV open (tb-OP) (nominal config):  
 L1 12. √RAD CNTLR OUT TEMP – NORM  
 13. √FLASH EVAP CNTLR PRI A,B (two) – OFF  
 ML31C 14. SPLY H2O TKD OUTLET – CL (tb-CL)  
 R11L 15. SPLY H2O TKB OUTLET – CL (tb-CL)  
 √TKA OUTLET – CL (tb-CL)  
 TKC INLET – CL (tb-CL)  
 TKC OUTLET – OP (tb-OP)

EV AW82D 16. √EMU 1(2) H2O WASTE – CL (tb-CL)  
SPLY – OP (tb-OP)

**WARNING**  
O2 will be off. IV stand by inner hatch  
Equal vlvs for emergency repress

EV DCM 17. O2 ACT – OFF, monitor SUIT P (√SUIT P > 3.6)

- \* When SUIT P ≤ 3.6: \*
- \* O2 ACT – PRESS until SUIT P = 4.2-4.4 \*
- \* – OFF \*

18. √STATUS: H2O WP ~8-15 psi and stable for ~30 sec (indicates charging complete), then:  
O2 ACT – PRESS until SUIT P = 4.2-4.4  
– EVA

IV R11L If SPLY H2O XOVR VLV closed (tb-CL or bp) (water transfer config):

19. SPLY H2O TKA OUTLET – OP (tb-OP)  
If SPLY H2O XOVR VLV open (tb-OP) (nominal config):

20. SPLY H2O TKC INLET – OP (tb-OP)  
TKB OUTLET – OP (tb-OP)

ML31C 21. SPLY H2O TKD OUTLET – OP (tb-OP)

22. If FES reqd, perform TOPPING FES STARTUP (ORB OPS, ECLS)

EV AW82D 23. EMU 1(2) H2O SPLY – CL (tb-CL)

**NOTE**

Disregard fault msgs until CWS updated with: O2  
ACT – EVA, WATER – ON, and H2O TEMP < 60

24. Go to DEPRESS/REPRESS Cue Card, DEPRESS, step 11  
(POST DEPRESS, step 1, if tunnel adapter)

**LiOH REPLACEMENT (MANNED)**

**CAUTION**  
If 10.2 cabin used, possible ΔP across LiOH  
cartridge caps. Direct ports away from face  
Limit exposure time of uncapped canister  
ports and avoid contact with seals

- IV 1. Unstow new LiOH cartridge with aluminum plate serial number facing self, remove caps (left first)
- IV 2. Unzip EMU thermal cover, fold back, Velcro to top of EMU

**WARNING**  
Fan will be off during changeout. Perform  
changeout as quickly as possible

**CAUTION**  
Vent loop is pressurized. Restrain LiOH cartridge

- DCM 3. √O2 ACT – IV
- 4. Helmet purge vlv – op
- 5. FAN – OFF

- IV EMU 6. Remove used cartridge
- 7. Holding new LiOH cartridge with aluminum plate serial number facing self, √O-ring seals for damage, install LiOH (attach Velcro retainer strap)

NOTE

EMU may issue CO2 HIGH or MONITOR CO2 message

- DCM 8. FAN – ON (PWR RESTART may occur)
- 9. Helmet purge vlv – cl, locked
- DCM 10. O2 ACT – PRESS
- 11. PURGE vlv – op (up)
- 12. Begin timing 2-min purge
- IV EMU 13. Close EMU thermal cover zipper
- 14. Place caps on used LiOH cartridge
- IV 15. Mark used cartridge, stow in middeck
- When purge time = 2 min:
- DCM 16. √STATUS: CO2 < 8.0 mmHg, then PURGE vlv – cl (dn)
- 17. O2 ACT – IV

NOTE

A minimum of 40 min of prebreathe reqd to condition LiOH cartridge

- 18. Continue EVA PREP or EMU PREBREATHE with minimum of 40 min prebreathe

**BATTERY REPLACEMENT (MANNED)**

- IV 1. Unstow new battery

CAUTION  
Do not allow battery to impact airlock wall and use care when handling/stowing battery to avoid damaging aluminum cover

- PLSS 2. Unzip EMU thermal cover, fold back, Velcro to top of EMU

WARNING  
Power switch must be in SCU during battery changeout  
Fan will be off during changeout. Perform changeout as quickly as possible

- DCM If no SCU power available:
- 3. √O2 ACT – IV
- 4. Helmet purge vlv – op
- 5. FAN – OFF

NOTE

EMU will be without comm after step 6 until battery power is restored at step 18

- DCM 6. PWR – SCU
- If degraded/dead battery:
- DCM 7. √PWR – SCU
- 8. √O2 ACT – IV
- 9. Helmet purge vlv – op
- DCM 10. FAN – OFF (fwd)
- PLSS 11. Open battery latch
- 12. Open LiOH cartridge latches

WARNING

Vent loop is pressurized. Restrain LiOH canister during battery changeout to avoid injury and breaking seal

- 13. Rotate LiOH cartridge outward until limited by Velcro retainer strap
- 14. Remove used battery
- 15. Install new battery (✓connector alignment); engage latch
- 16. ✓LiOH cartridge seated in vent ports, rotate downward until latch pins engage
- 17. Close LiOH cartridge latches
- If no SCU power available:
- DCM 18. PWR – BATT
- 19. FAN – ON (aft) (PWR RESTART may occur)
- 20. Helmet purge vlv – cl, locked

- |      |                                |   |
|------|--------------------------------|---|
| *    | If LiOH cartridge seal broken: | * |
| *DCM | 21. O2 ACT – PRESS             | * |
| *    | 22. PURGE vlv – op (up)        | * |
| *    | 23. Begin 2 min purge          | * |
| *    | When 2 min complete:           | * |
| *DCM | 24. PURGE vlv – cl (dn)        | * |
| *    | 25. O2 ACT – IV                | * |

- DCM 26. ✓STATUS: BATT VDC
- 27. Report following to MCC as comm permits:
  - Old battery barcode/serial number and stowage location
  - New battery barcode/serial number and BATT VDC reading
- 28. Close EMU thermal cover zipper

NOTE

EMU-calculated TIME EV and TIME LF do not reset despite battery changeout. A cold restart is reqd to reset those parameters

- 29. If reqd per MCC, perform EMU COLD RESTART (EMU CONT PROCS)
- 30. Continue EVA PREP

## WATER DUMP

I

- BOTH 1. Connect SCUs to DCM,  $\sqrt$ locked  
DCM 2. PWR – BATT

**CAUTION**  
EMU must be on BATT pwr when  
airlock pwr supply turned on

- AW18H 3. PWR/BATT CHGR EMU 1,2 MODE (two) – PWR  
BUS SEL (two) – MNA(MNB)
- DCM 4. PWR – SCU
- WCS 5.  $\sqrt$ FAN SEP same as HOSE BLOCK  
6. MODE – COMMODE/MANUAL/EMU; posn guard over sw  
( $\sqrt$ airflow, WCS ON It on)
- AW82D 7.  $\sqrt$ EMU 1,2 H2O SPLY (two) – CL (tb-CL)  
8. Remove helmets with sunshades down and helmet covers installed; stow  
9. Install SCOFs, lock
- DCM 10. O2 ACT – IV
- AW82D 11. EMU 1,2 H2O WASTE reg (two) – MAN OP

### NOTE

EMU will be dumped serially in step 12

12. EMU 1(2) H2O WASTE (one) – OP (tb-OP) (until H2O WP < 7  
and stable for ~1 min)  
– CL (tb-CL)  
– Repeat for other EMU
- AW82H 13. EMU 1,2 H2O WASTE reg (two) – REGULATING
- DCM 14. O2 ACT – OFF  
15. Remove SCOFs, stow  
16. Install helmets with covers, lock
- WCS 17. MODE – AUTO ( $\sqrt$ WCS ON It off)

## SCU SWAP (UNMANNED)

- BOTH DCM 1. √FAN – OFF
- 2. √O2 ACT – OFF
- 3. √COMM mode – OFF
- AW18H 4. PWR/BATT CHGR EMU 1,2 BUS SEL (two) – OFF
- DCM 5. Swap SCUs
- 6. PWR – BATT
- AW18H 7. √PWR/BATT CHGR EMU 1,2 MODE (two) – PWR
- 8. PWR/BATT CHGR EMU 1,2 BUS SEL (two) – MNA(MNB)
- 9. √EMU INPUT 1,2 volts = 18.0-20.0
- DCM 10. PWR – SCU

## SCU SWAP (MANNED)

- BOTH DCM 1. Temp control vlv – Max C
- O6:A1R 2. Perform EVA COMM CONFIG (EVA PREP), steps 2, 3, and 6
- DCM 3. COMM mode – PRI
- 4. √Comm FREQ – LOW
- 5. PWR – BATT
- AW18H 6. PWR/BATT CHGR EMU 1,2 BUS SEL (two) – OFF
- DCM 7. Swap SCUs
- AW18H 8. √PWR/BATT CHGR EMU 1,2 MODE (two) – PWR
- 9. PWR/BATT CHGR EMU 1,2 BUS SEL (two) – MNA(MNB)
- 10. √EMU INPUT 1,2 volts = 18.0-20.0
- DCM 11. PWR – SCU
- 12. COMM mode – HL
- 13. Temp control vlv – as reqd

## EMU COLD RESTART (MANNED)

### WARNING

This procedure should only be used at airlock pressures of 8.0 psi and higher. Fan and O2 will be off during restart. Perform restart as quickly as possible

- DCM 1. FAN – OFF
- 2. O2 ACT – OFF
- If PWR – SCU:
  - 3. PWR – BATT (2 sec)
  - 4. PWR – SCU
- If PWR – BATT:
  - 5. PWR – SCU (2 sec)
  - 6. PWR – BATT
- 7. O2 ACT – IV
- 8. FAN – ON

## 12.1 STS EVA DECONTAMINATION

Crew Visually Detects Plume, Leaking QD, White Crystals, or "Snow" Coming from Orbiter/Station During EVA

Orbiter/Station Chemical System Leak Suspected Due to Steady (not Step Function) Decrease in Pressure or Temperature

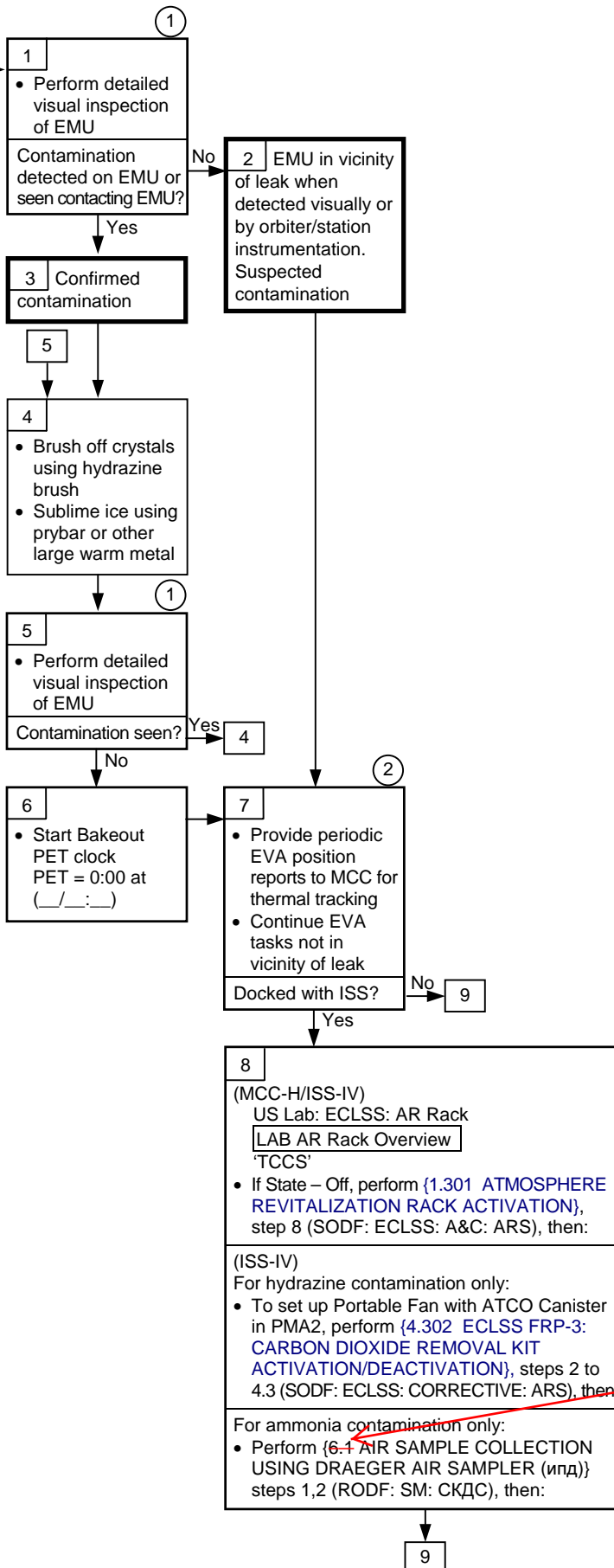

**1**

Ammonia visual inspection should be performed in night or shaded ambient light with helmet spot lights used to illuminate TMG. Use of sunvisor during inspection should be avoided. View TMG from an oblique angle. Following are indications of ice on EMU:

- Loss of TMG thread pattern
- Waxy gloss or hard pack snow appearance
- Unusual contours

**2**

For confirmed contamination 1:55 (2:10 if from ISS thruster) of EMU consumables must be available to support activities from ingress through EMU doffing. For suspected contamination 0:55 (1:10 if from ISS thruster) of consumables reqd. EVA tasks must be deferred to protect these consumables. Bakeout on SCU does not consume Metox/LiOH if helmet purge valve is open

7.1

P & I



## 12.1 (Cont)

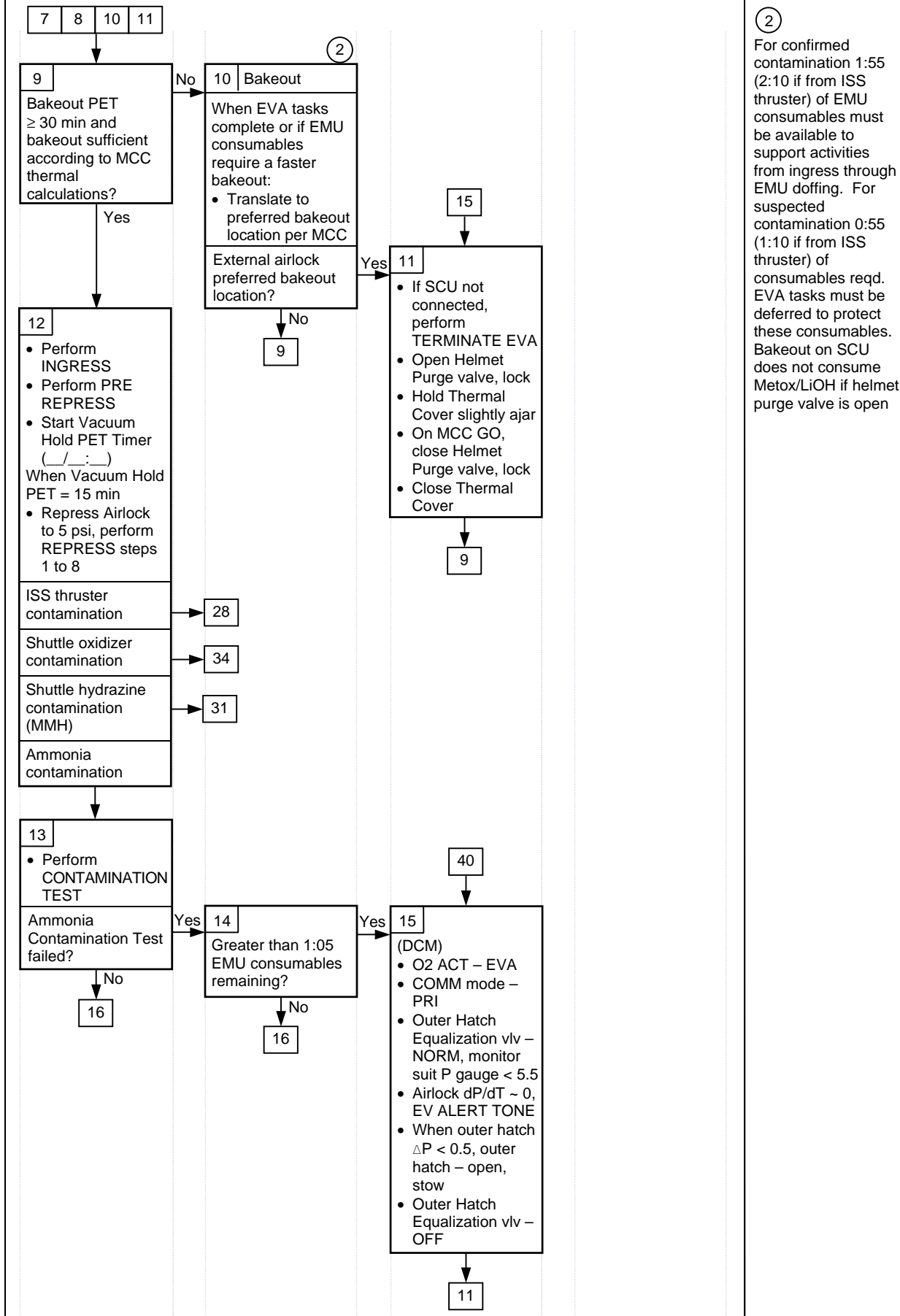

②  
For confirmed contamination 1:55 (2:10 if from ISS thruster) of EMU consumables must be available to support activities from ingress through EMU doffing. For suspected contamination 0:55 (1:10 if from ISS thruster) of consumables reqd. EVA tasks must be deferred to protect these consumables. Bakeout on SCU does not consume Metox/LiOH if helmet purge valve is open

## 12.1 (Cont)

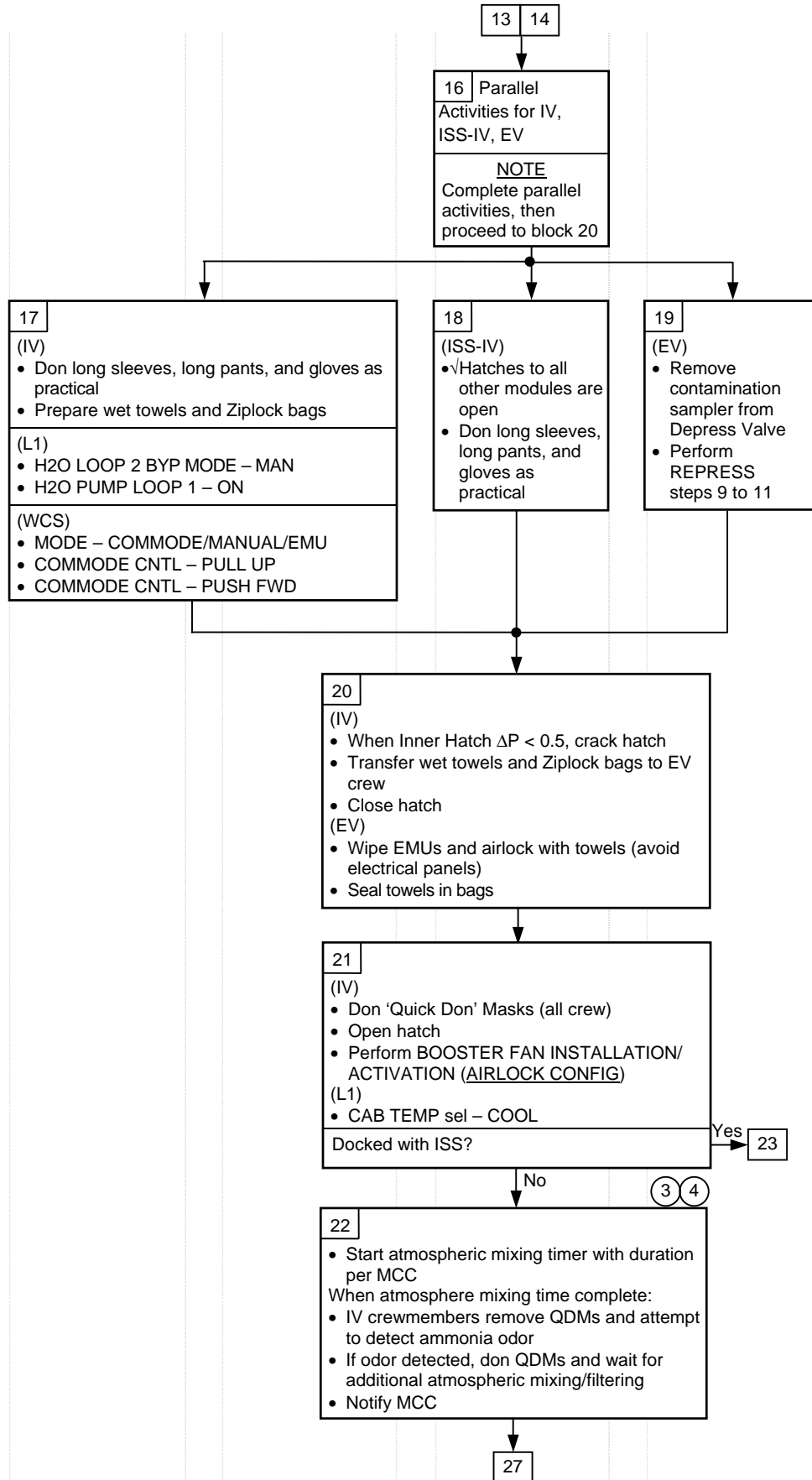

③

For ammonia or oxidizer only, if the contamination test passed at 5 psia, no further mixing is required. If the test failed and EMU consumables would not support an additional depress/repress cycle, atmospheric mixing with Booster Fan should be performed for 10 min to completely mix the airlock and crew module. Maximum dilution is approximately 12:1 (airlock only) or 7:1 (tunnel adapter). Dilution with ISS will further reduce concentration by 6:1 over 2 hr

④

The WCS filter will reduce ammonia concentration by 63% every 60 min for a shuttle equivalent volume

## 12.1 (Cont)

21

23

- (MCC-H)
- Inhibit ISS Rapid Depress Response and Alarm
  - Verify Russian Segment Rapid Depress Response inhibited
- (EV)
- ODS Upper Hatch Equal vlv – NORM
  - When ODS Upper Hatch  $\Delta P < 0.5$ , open hatch
  - ODS Upper Hatch Equal vlv – OFF
- (ISS IV)
- Don PBA (all crew)
  - Perform {2.104 HATCH OPEN AND SHUTTLE/ISS DUCT INSTALLATION} step 13 to end of procedure (SODF: JNT OPS: INGRESS STATION), then:

25

24

- (ISS IV)
- In airlock, perform {6.4 AIR SAMPLE COLLECTION USING DRAEGER AIR SAMPLER (инд)} step 3 (RODF: SM: СКДС), then:

7.1

Draeger reading > 10 ppm?

Yes

25

- (ISS IV)
- Egress Airlock
  - Discard used Draeger tube
  - Wait 10 min for atmospheric mixing and dilution

24

No

26

- Doff PBA and QDMs
- Discard used Draeger tube and tips
- Stow unused Draeger tubes and pump

22

27

- On MCC call:
- Perform POST EVA

(L1)

- H2O PUMP LOOP 1 – GPC
- H2O LOOP 2 BYP MODE – AUTO
- CAB TEMP sel – adj rotary as desired

(WCS)

- COMMODE CNTL – OFF (BACK/DOWN)
- MODE – AUTO

P & I

## 12.1 (Cont)

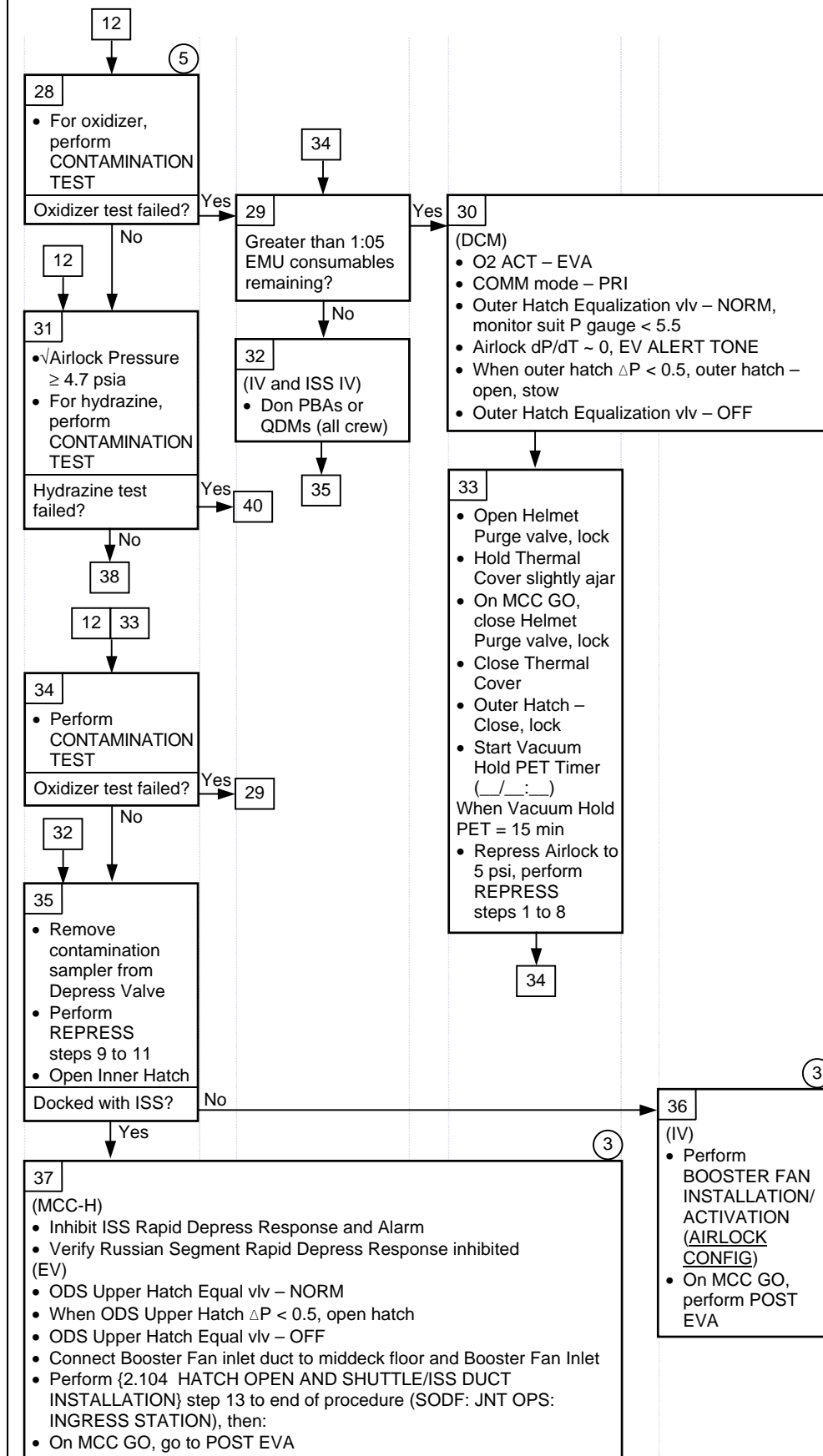

③ For ammonia or oxidizer only, if the contamination test passed at 5 psia, no further mixing is required. If the test failed and EMU consumables would not support an additional depress/repress cycle, atmospheric mixing with Booster Fan should be performed for 10 min to completely mix the airlock and crew module. Maximum dilution is approximately 12:1 (airlock only) or 7:1 (tunnel adapter). Dilution with ISS will further reduce concentration by 6:1 over 2 hr

⑤ On ISS, it is impossible to determine if a propulsion leak was fuel or oxidizer. Therefore, tests must be performed for both oxidizer and UDMH

## 12.1 (Cont)

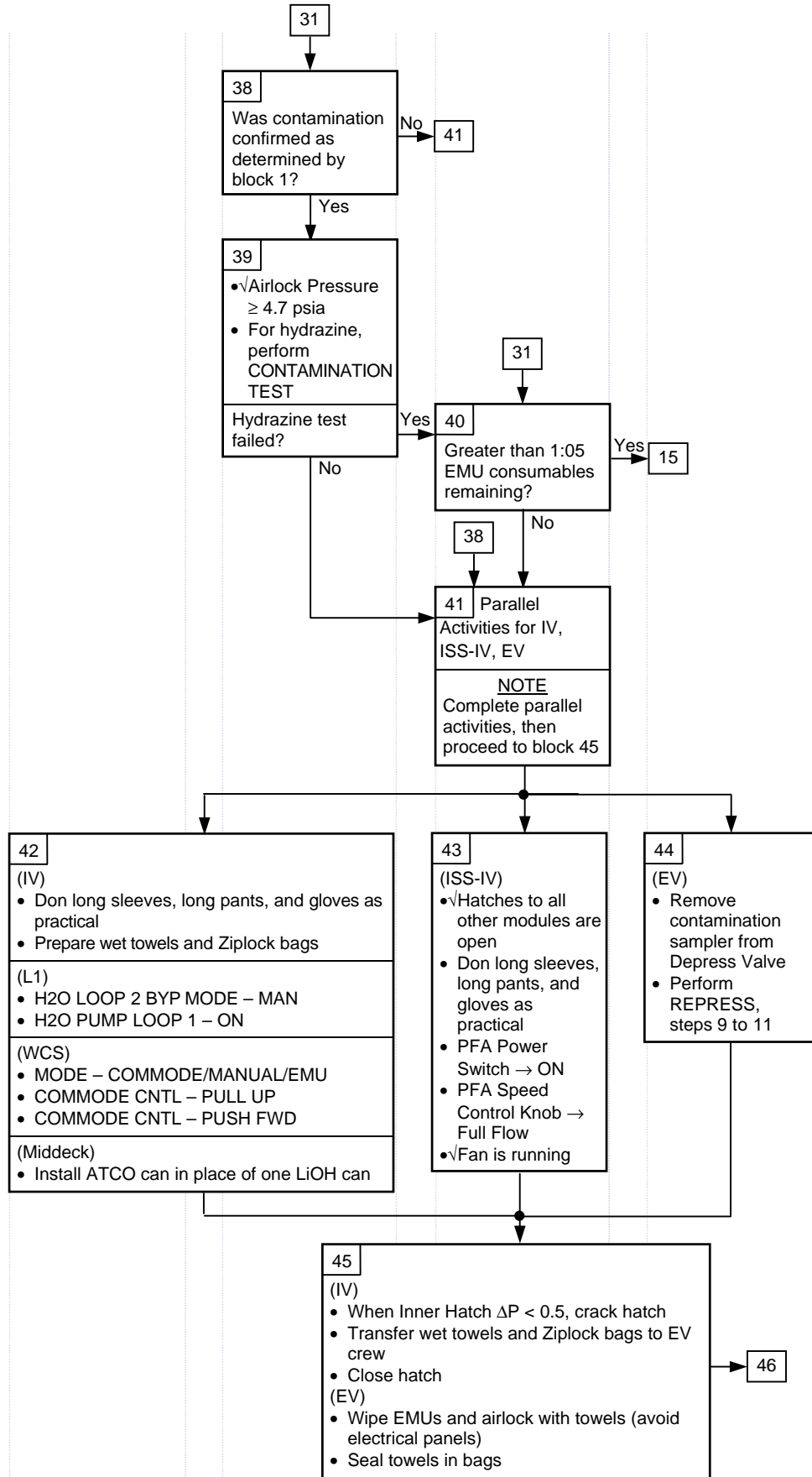

## 12.1 (Cont)

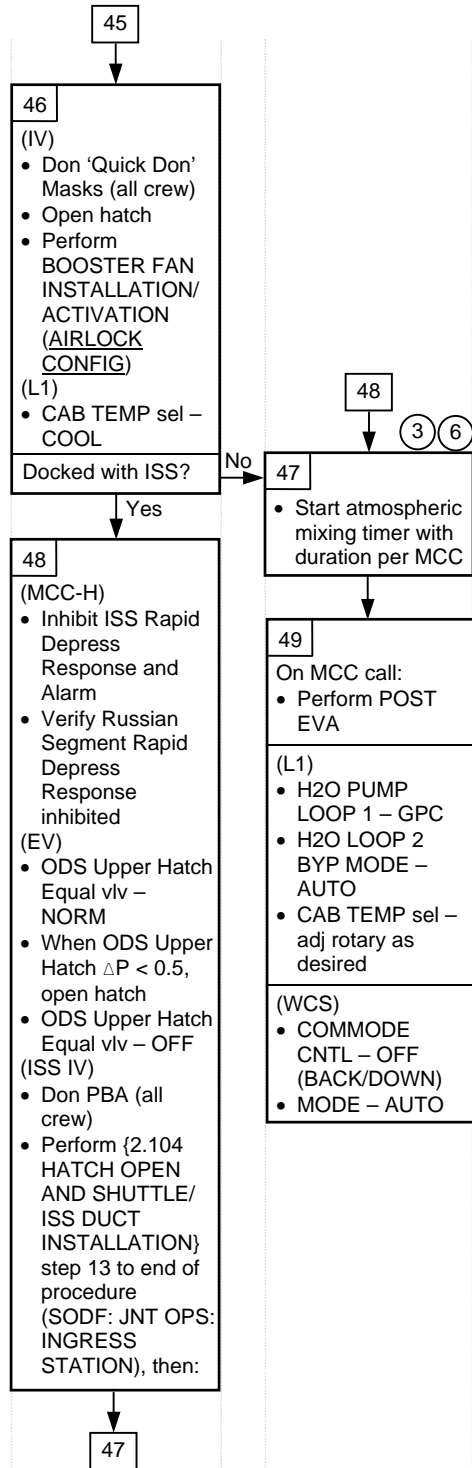

③

For ammonia or oxidizer only, if the contamination test passed at 5 psia, no further mixing is required. If the test failed and EMU consumables would not support an additional depress/repress cycle, atmospheric mixing with Booster Fan should be performed for 10 min to completely mix the airlock and crew module. Maximum dilution is approximately 12:1 (airlock only) or 7:1 (tunnel adapter). Dilution with ISS will further reduce concentration by 6:1 over 2 hr

⑥

Each ATCO canister will reduce the hydrazine concentration by 63% every 90 min for a shuttle equivalent volume

## CONTAMINATION TEST

To be performed in conjunction with 12.1 STS EVA DECONTAMINATION. It is performed with the external airlock at 5 psia following suspected hydrazine or oxidizer contamination

- EV  
IV
1. √Inner hatch Equal vlv (two) – OFF
  2. Wait 30 sec for pressure stabilization  
Record AIRLK P from EV DCM

	1	2	3
2. AIRLK P			

- EV AW82B 3. Attach STS Contamination Sampler to depress valve  
AW18A 4. √LTG FLOOD (four) – ON  
5. Go to appropriate chemical test steps below

### AMMONIA CONTAMINATION TEST

6. Using RET, retrieve ammonia detector from Contamination Detection Kit
7. Verify Draeger tube color – yellow

\* Use new tube if not proper color \*

#### CAUTION

Minimize contact with fracture regions of Draeger tube. Minor glove RTV damage is possible, but protective pressure bladders and restraints unaffected

- AW82B 8. Using equipment hook of RET as a lever, break off both tether points on ammonia detector  
9. Insert ammonia detector into STS Contamination Sampler with orientation that allows number scale to be read

#### WARNING

Precise sampling times are critical for accurate testing. IV should coordinate start of timer with opening of AIRLK DEPRESS valve

10. AIRLK DEPRESS vlv – 5
  11. Start timer (3:30 sampling time)
- When timer expired:
12. AIRLK DEPRESS vlv – CL

#### NOTE

If ammonia is present, Draeger tube will turn deep blue

- DCM 13. Compare AIRLK P to pressure in step 2  
If  $\Delta P \geq 0.1$  psi (indicates leak in sampling hardware):
14. To repress airlock to 5.0 psi, Inner hatch Equal vlv (one) – throttle NORM to OFF
  15. Go to step 1 to repeat test with new Draeger tube
  16. Determine test results based on table 1 and report to MCC

TABLE 1.- AMMONIA TEST PASS/FAIL CRITERIA

Reaction Line	Report Status	Assumed Concentration with 2x Factor of Safety
None seen	Passed	10 ppm
$0 < X < 2$	Passed	30 ppm
$2 < X < 5$	Failed	60 ppm
$5 < X < 25$	Failed	180 ppm

17. Continue 12.1 STS EVA DECONTAMINATION

OXIDIZER CONTAMINATION TEST

18. Using RET, retrieve nitrous fumes detector from Contamination Detection Kit

19. Verify Draeger tube color pale gray

\* Use new tube if not proper color \*

CAUTION

Minimize contact with fracture regions of Draeger tube. Minor glove RTV damage is possible, but protective pressure bladders and restraints unaffected

AW82B 20. Using equipment hook of RET as a lever, break off both tether points on nitrous fumes detector

WARNING

Precise sampling times are critical for accurate testing. IV should coordinate start of timer with opening of AIRLK DEPRESS valve

21. AIRLK DEPRESS vlv – 5

22. Start timer (15:00 sampling time)

When timer expired:

23. AIRLK DEPRESS vlv – CL

NOTE

If oxidizer present, Draeger tube will turn blue gray

DCM 24. Compare AIRLK P to pressure in step 2

If  $\Delta P \geq 0.1$  psi (indicates leak in sampling hardware)

25. To repress airlock to 5.0 psi, Inner hatch Equal vlv (one) – throttle NORM to OFF

26. Go to step 1 to repeat test with new Draeger tube

27. Determine test results based on table 2 and report to MCC

TABLE 2.- OXIDIZER TEST PASS/FAIL CRITERIA

Reaction Line	Report Status	Assumed Concentration with 2x Factor of Safety
$X < 0.5$	Passed	1.5 ppm
$0.5 < X < 1$	Failed	3 ppm
$1 < X < 2$	Failed	6 ppm

28. Continue 12.1 STS EVA DECONTAMINATION



## HYDRAZINE CONTAMINATION TEST

29. Retrieve hydrazine detector from Contamination Detection Kit

### NOTE

Hydrazine detector is double bagged. Inner bag is not captive and should be constrained to prevent FOD

30. Tear open hydrazine detector packaging  
Stow packaging in small trash bag
31. ✓ Initial coupon color – white
- AW82B 32. Insert hydrazine detector into STS Contamination Sampler
33. Helmet Lights – OFF

### WARNING

Precise sampling times are critical for accurate testing. IV should coordinate start of timer with opening of AIRLK DEPRESS valve

34. AIRLK DEPRESS vlv – 5
35. Start timer (10:00 sampling time)  
When timer expired:
  36. AIRLK DEPRESS vlv – CL
- DCM 37. Compare AIRLCK P to pressure in step 2  
If  $\Delta P \geq 0.2$  psi (indicates leak in sampling hardware)
  38. To repress airlock to 5.0 psi, Inner hatch Equal vlv (one) – throttle NORM to OFF
  39. Go to step 1 to repeat test with new hydrazine detector

### NOTE

Hue and intensity of test coupon color change is proportional to hydrazine concentration. For shuttle thruster leaks, compare coupon to US Propellant (MMH) color scale. For ISS thruster leaks, compare coupon to Russian Propellant (UDMH) color scale

40. Determine test results based on table 3 and report to MCC

TABLE 3.- HYDRAZINE TEST PASS/FAIL CRITERIA

MMH	Report Status	Assumed Concentration with 2x Factor of Safety
No color change seen	Passed	28 ppb
Unexposed < X < 25 ppb	Passed	50 ppb
25 ppb < X < 50 ppb	Failed	100 ppb
50 ppb < X < 100 ppb	Failed	200 ppb
UDMH		
No color change seen	Passed	54 ppb
Unexposed < X < 50 ppb	Passed	100 ppb
50 ppb < X < 100 ppb	Failed	200 ppb
100 ppb < X < 300 ppb	Failed	600 ppb

41. Continue 12.1 STS EVA DECONTAMINATION

## SAFER BATTERY CHANGEOUT (15 min)

1. Unstow new battery
- PM 2. Install Inhibitor
3. ✓MAN ISOL vlv – CL (up)
- HCM 4. ✓PWR – OFF
- PM 5. Remove T-Handle tool from lanyard while keeping Inhibitor installed on SAFER
6. Separate TMG Velcro on bottom of prop module to access battery
7. Loosen captive screws (eight) using 9/64-in Hex Wrench on T-Handle tool
8. Remove battery; disconnect battery umbilical connector
9. Stow used battery
10. Record new battery serial number (SAFER CHECKOUT RESULTS Cue Card)  
Report old battery serial number and new stowage location to MCC as comm permits
11. Connect new battery umbilical connector; install battery
12. Tighten captive screws (eight)
13. Reattach TMG Velcro
14. Attach T-Handle tool to lanyard
15. Go to SAFER CHECKOUT

## BENDS TREATMENT ADAPTER (BTA) INSTALLATION (IN-SUIT)

### BTA PREP

- EMU
1. Unstow BTA with 3/8-in Wrench
  2. Cut/break TMG tacks (see 12-23)
  3. Unzip PLSS TMG (avoid pulling on antenna cable)
  4. Remove impact shield
  5. Disconnect hatch marked cable P3 (see 12-23); cut cable if reqd

### NOTE

It may be necessary to extend the legs forward to access the test port in a pressurized EMU

6. Remove test port F plug on SOP using 3/8-in end of BTA Wrench (4-6 turns ccw) (see SECONDARY OXYGEN PACKAGE below)

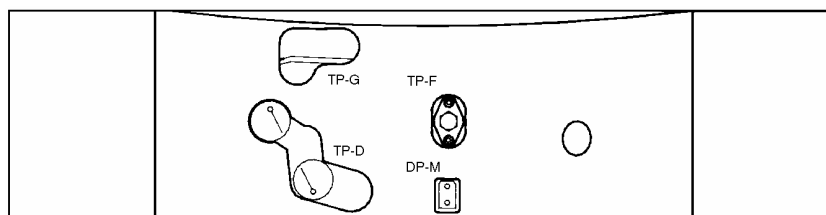

**SECONDARY OXYGEN PACKAGE**

- BTA
7. Stow test port F plug (see 12-23) on BTA
  8. Unstow poppet keeper screw from BTA, temp stow in EMU Servicing Kit

### BTA TREATMENT

9. √SCU connected to DCM
  10. Align BTA engage mark with PPRV mark  
Connect BTA to PPRV (rotate BTA cw to hard stop to lock), √locked
  11. √EV-1(EV-2) O2 vlv – OP
  12. √EMU O2 ISOL vlv – OP
  13. √PWR – SCU
  14. √FAN – ON
  15. √COMM mode – HL, vol as reqd
  16. DISP – PRO until **BTA?OFF** displayed
    - YES (hold for 2 sec), verify **ENABLE BTA?** displayed
    - YES (hold for 2 sec), verify **BTA ENABLED** displayed
- If biomed reqd:
17. Perform EVA COMM CONFIG (EVA PREP), steps 1-6
  18. Comm FREQ – LOW  
COMM mode – PRI
19. √FAN SEP same as HOSE BLOCK
  20. MODE – COMMODE/MANUAL/EMU, posn guard over sw (√airflow, WCS ON It on)
  21. √EMU 1(2) H2O SPLY – CL (tb-CL)
  22. EMU 1(2) H2O SPLY WASTE reg – MAN OP
  23. EMU 1(2) H2O WASTE – OP (tb-OP) (until H2O WP < 7 and stable for ~1 min)
  24. EMU 1(2) H2O WASTE – CL (tb-CL)
  25. EMU 1(2) H2O SPLY WASTE reg – REGULATING
  26. MODE – AUTO (√WCS ON It off)
  27. √STATUS: **SUIT P** = 4.2-4.4
  28. O2 ACT – OFF (until SUIT P stabilizes)

NOTE

Suit pressure will nominally increase when O2 actuator taken to OFF. Suit P = H2O GP when O2 ACT – OFF. For actual suit P > 5.9 psi, suit P can only be directly read as H2O GP; actual suit P = 4.7 to 5.5 psi above BTA gauge pressure

CAUTION

If BTA gauge pressure increases while O2 ACT – PRESS, immediately set O2 ACT – OFF to prevent a hazardous condition; contact MCC

29. O2 ACT – PRESS (for 15 sec), √BTA gauge not increasing when O2 ACT – PRESS
30. O2 ACT – OFF (until H2O GP stable)
31. √STATUS: H2O GP  
DISP – YES (hold for 2 sec) to lock parameter; re-lock every 5 min
32. Repeat steps 29,30 until H2O GP = 6.0 psid and stable on DCM display with O2 ACT – OFF

As reqd to maintain H2O GP = 6.0 psid:

33. Repeat steps 29,30

NOTE

Initial treatment will be at 6 psid for Cuffs 2 and 3 and will be increased to 8 psid if symptoms do not resolve. Initial treatment for Cuff 4 will be 8 psid

34. Contact Surgeon for treatment length and changes in treatment pressure

## BENDS TREATMENT ADAPTER (BTA) INSTALLATION (POST SUIT DOFFING)

### BTA PREP

- EMU
1. Unstow BTA with 3/8-in Wrench
  2. Cut/break TMG tacks (see 12-23)
  3. Unzip PLSS TMG (avoid pulling on antenna cable)
  4. Remove impact shield
  5. Disconnect hatch marked cable P3, cut cable if reqd (see 12-23)
  6. Remove test port F plug on SOP using 3/8-in end of BTA Wrench (4-6 turns ccw) (see SECONDARY OXYGEN PACKAGE below)

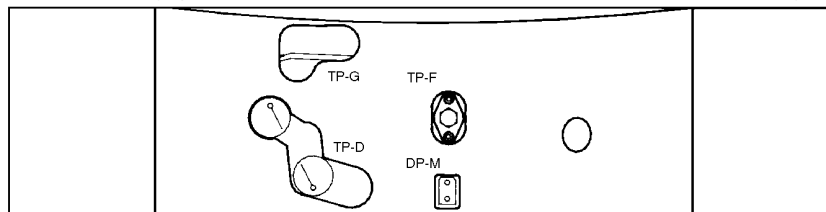

**SECONDARY OXYGEN PACKAGE**

- BTA
7. Stow test port F plug (see 12-23) on BTA
- If LiOH replacement reqd by MCC:
8. Unstow new LiOH cartridge
  9. Remove used LiOH cartridge
  10. Holding new LiOH cartridge w/aluminum plate serial number facing self, remove caps (left first),  $\checkmark$ O-ring seals for damage, install LiOH (attach Velcro retainer strap)
  11. Install caps on used LiOH cartridge  
Tape an X on used LiOH cartridge and stow

### BTA TREATMENT

12.  $\checkmark$ SCU connected to DCM
  13. Unstow Poppet Keeper Screw from BTA
  14. Open Positive Pressure Relief Valve (PPRV) using BTA poppet keeper (thread cw to hard stop, pull, tighten nut) (see 12-23)
  15. Align BTA engage mark with PPRV mark  
Connect BTA to PPRV (rotate BTA cw to hard stop to lock);  $\checkmark$ locked
  16. Don MAG, LCVG, biomed
  17. Fill drink bag from galley, remove gas and insert drink bag in restraint bag
  18. Install Drink Bag Restraint Bag in HUT and dispose of fill tool in wet trash
  19.  $\checkmark$ EV-1(EV-2) O2 vlv – OP
  20.  $\checkmark$ EMU O2 ISOL vlv – OP
  21. PWR – BATT
- AW82B
- MD(flr)
- DCM

#### CAUTION

EMU must be on BATT pwr when  
airlock pwr supply turned on

- AW18H
22. PWR/BATT CHGR EMU 1(2) MODE – PWR  
BUS SEL – MNA(MNB)
- DCM
23. PWR – SCU
  24.  $\checkmark$ Waist ring – op
  25. Don LTA (attach donning handles as reqd)
  26.  $\checkmark$ Suit arms aligned
  27.  $\checkmark$ Wrist disconnects – op
  28. Don thumb loops
  29.  $\checkmark$ Biomed connector outside of HUT
  30. Don HUT

31. Release thumb loops
  32. √Suit arms aligned
  33. Don comm cap
  - DCM 34. √COMM mode – HL, vol as reqd  
If biomed reqd:
  - DCM 35. Perform EVA COMM CONFIG (EVA PREP), steps 1-6
  - DCM 36. Comm FREQ – LOW  
COMM mode – PRI
  37. Connect biomed to elec harness
  38. Connect LCVG to multiple water connector, √locked
  39. √Thermal cover clear of waist ring
  40. Waist ring – engage posn
  41. Connect waist ring to HUT, √locked
  42. Wrist rings – engage posn
  43. Don EV gloves, √locked
  44. √Mike boom posn
  - DCM 45. FAN – ON
  46. √Elec harness clear of neck ring
  47. Don helmet, √locked
  48. √Helmet purge vlv – cl, locked
  49. √PURGE vlv – op
  50. O2 ACT – PRESS, begin purge clock (12 min)
  - WCS 51. √FAN SEP same as HOSE BLOCK
  52. MODE – COMMODE/MANUAL/EMU, posn guard over sw (√airflow, WCS ON It on)
  - AW82D 53. √EMU 1(2) H2O SPLY – CL (tb-CL)
  - AW82H 54. EMU 1(2) H2O SPLY WASTE reg – MAN OP
  - AW82D 55. EMU 1(2) H2O WASTE – OP (tb-OP)
  - When N2 purge time = 12 min:
  - AW82H 56. EMU 1(2) H2O WASTE – CL (tb-CL)
  57. EMU 1(2) H2O SPLY WASTE reg – REGULATING
  - WCS 58. MODE – AUTO (√WCS ON It off)
  - DCM 59. PURGE vlv – cl (dn)
  60. √STATUS: SUIT P = 4.2-4.4
  61. DISP – PRO until BTA?OFF displayed
    - YES (hold for 2 sec), verify ENABLE BTA? displayed
    - YES (hold for 2 sec), verify BTA ENABLED displayed
- NOTE  
Suit P will increase about ~.5 psi each time O2 ACT – OFF
62. O2 ACT – OFF (until Suit P incr stabilizes)
  63. O2 ACT – PRESS (for 15 sec)
  64. Repeat steps 62,63 until Suit P = 6.0 psig on BTA gauge
- NOTE  
BTA relief valve relieves at 7.95-8.45 psig
- As reqd to maintain Suit P = 6.0 psig:
65. Repeat steps 62,63
- NOTE  
Initial treatment will be at 6 psid for Cuffs 2 and 3 and will be increased to 8 psid if symptoms do not resolve. Initial treatment for Cuff 4 will be 8 psid
66. Contact Surgeon for treatment length and changes in treatment pressure

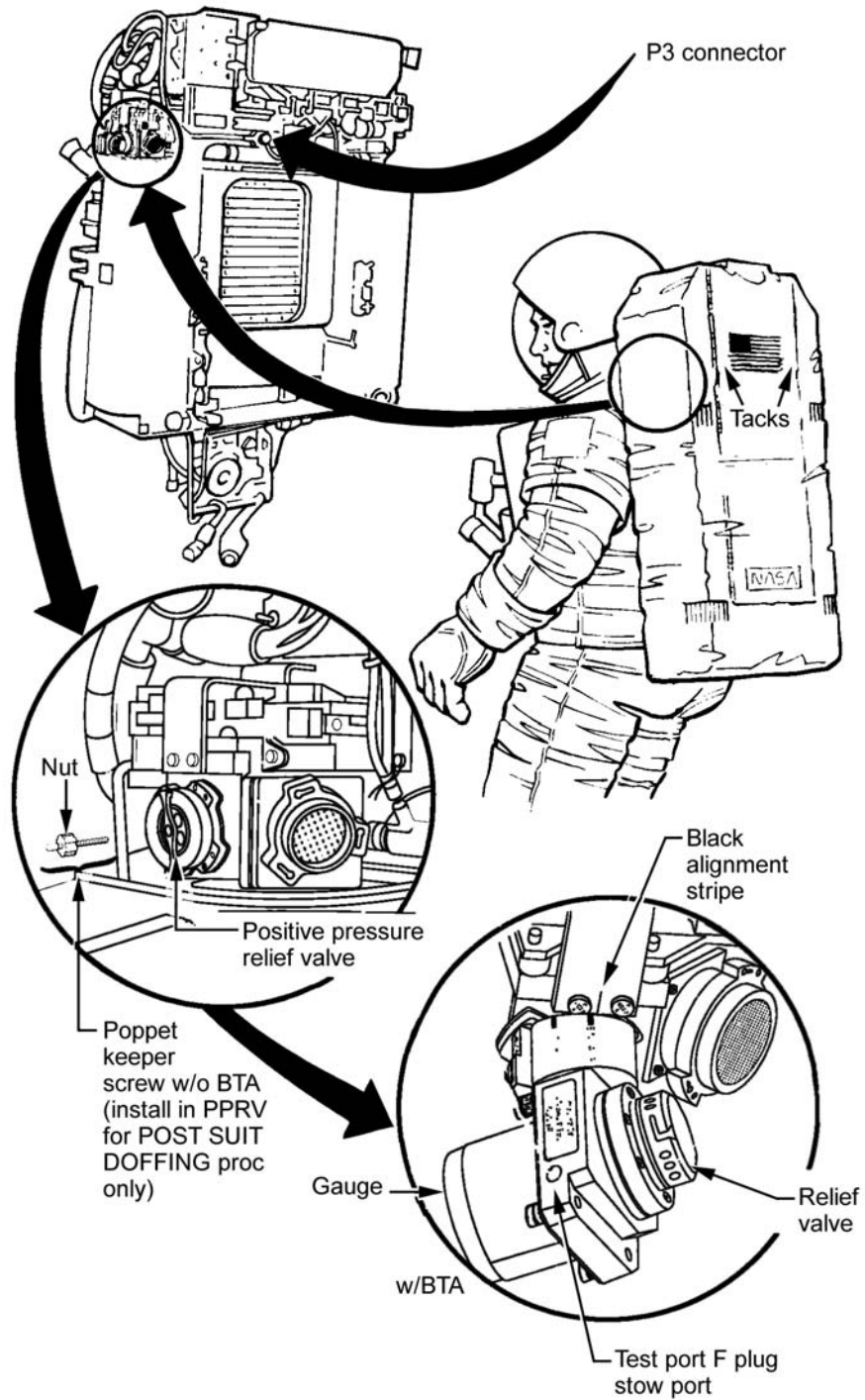

**BTA LOCATION ON EMU**

## EMU RESIZE (30 min)

### NOTE

Procedures written for arm, thigh, and boot disconnects. Arm, thigh, and boot sizing rings are not interchangeable and cannot be stacked. See figures below and next page as reference during procedure

Old component(s)/ EMU

1. Identify component(s) to be installed per appropriate resize matrix
  2. Peel back TMG from disconnect
- If replacing arm components:
3. ✓ REBA sw – OFF (toward left arm of suit)
  4. Disconnect lower arm power harness from gloves and upper arm

### WARNING

Threads on sizing rings and arm/leg/boot segments have sharp edges. Avoid contact with skin and suit bladder

5. Lock 1 – OPEN (on arm, lock may reengage due to bladder)
6. Lock 2 – hold OPEN while turning ring to engage lock 2 OPEN against disconnect
7. Lock 3 – hold OPEN while turning ring in OPEN direction
8. Demate segment/ring
9. Install protective caps on ends of components; place rings in protective pouches
10. Repeat steps 2-9 as reqd

New component(s)/ EMU

11. ✓ Proper size located on bladder by disconnect
12. ✓ All seals, threads and wipe with lint-free wipe (EMU Servicing Kit)
13. Lock 1 – OPEN (lock may reengage due to bladder on arm)
14. Align new component yellow hash marks with yellow bar on disconnect
15. Turn rings in LOCK direction
16. ✓ Lock 2,3 – locked
17. Lock 1 – LOCK
18. ✓ Cam adjustments (4 per segment) per appropriate resize matrix
19. If lower arm replaced, connect lower arm power harness to upper arm
20. Remate TMG covering disconnect
21. Repeat steps 11-20 as reqd

Old component(s)/ EMU

22. Stow replaced component(s)

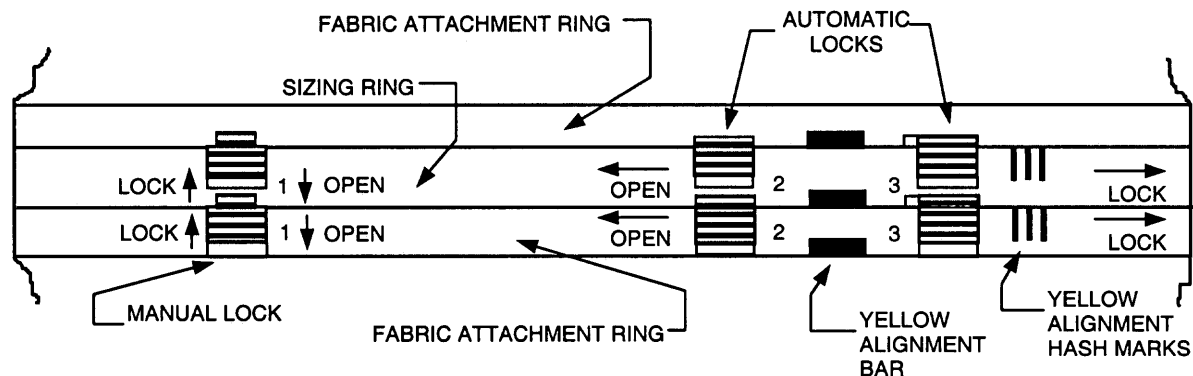

**DISCONNECT IN LOCKED POSITION**



## EMU RESIZE (Cont)

### ARM CAM ADJUSTMENT

(0.25-in per cam)

#### NOTES

Cam Adjuster only rotates in one direction.

Cam Adjuster should click and lock in the full SHORT and full LONG positions.

Cam positions/arms must be symmetric; likely minimum of four (4) cams to be adjusted

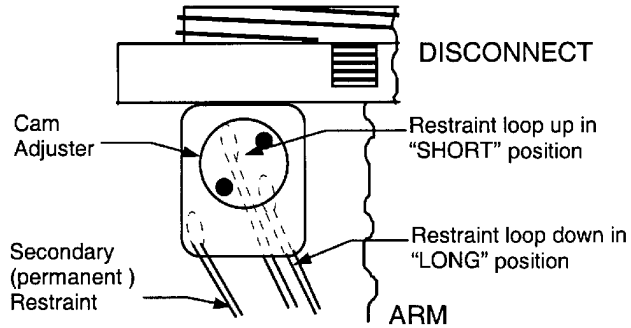

### WAIST CAM ADJUSTMENT

(1.0-in per cam)

#### NOTES

After adjusting, verify that restraint is routed around proper pin; that material is not damaged, twisted or pinched; and that movable pin is fully inserted.

With restraint in LONG position, the darkened area on Resizing Pull Tab should NOT be easily visible.

With restraint in SHORT position, the darkened area on Resizing Pull Tab should be easily visible.

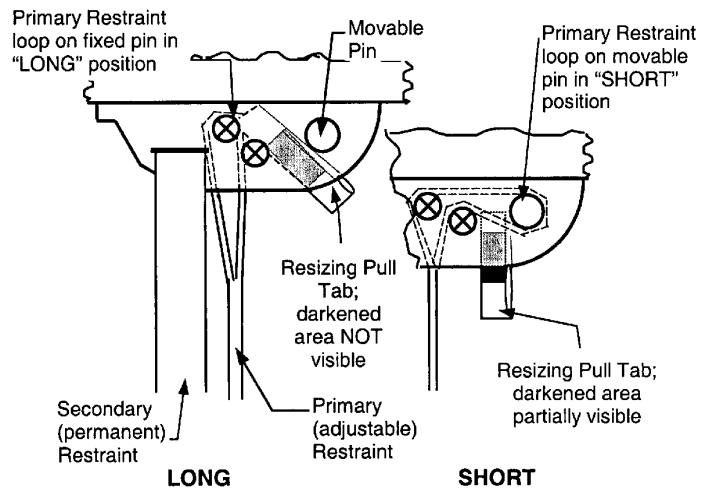

Cam positions must be symmetric; minimum of two (2) cams to be adjusted

### LEG CAM ADJUSTMENT

(0.5-in per cam)

#### NOTE

After adjusting, verify that restraint is routed around the oval cam; that material is not damaged, twisted or pinched; and that Movable Pin is fully inserted.

Cam positions/legs must be symmetric; likely minimum of four (4) cams to be adjusted

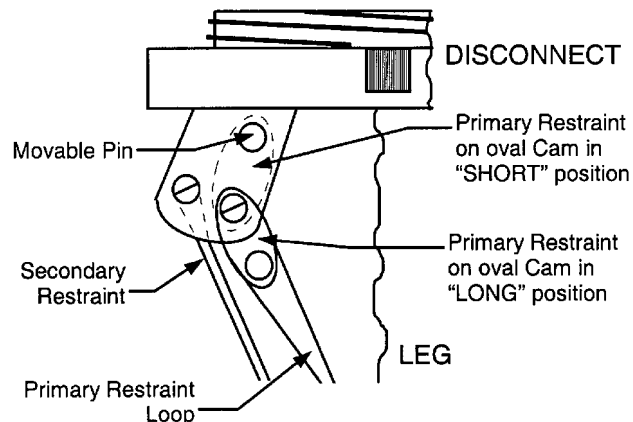

#### CAUTION

In SHORT position, the Movable Pin must be inserted thru oval cam, not just thru the restraint loop

In LONG position, the restraint must NOT be around the Movable Pin; verify that oval cam and restraint are down

This Page Intentionally Blank

Replace this page with page(s) from Flight Supplement

Replace this page with page(s) from Flight Supplement

ORBITER CONTINGENCY EVA

PAYLOAD BAY EVA NOMENCLATURE .....	14-2
RMS/PRLA CONTINGENCY EVA.....	14-3
96 BOLT PRE-EVA TOOL CONFIG .....	14-13
EVA TIMELINE.....	14-14
CAPTURE LATCH MANUAL RELEASE (ODS/PMA) .....	14-19
96 BOLT EVA LAYOUT .....	14-21
PLBD LATCH TOOL PLACEMENT WITH DUAL LATCH GANG FAILURES .....	14-22

ORB CONT  
EVA

PAYLOAD BAY EVA NOMENCLATURE

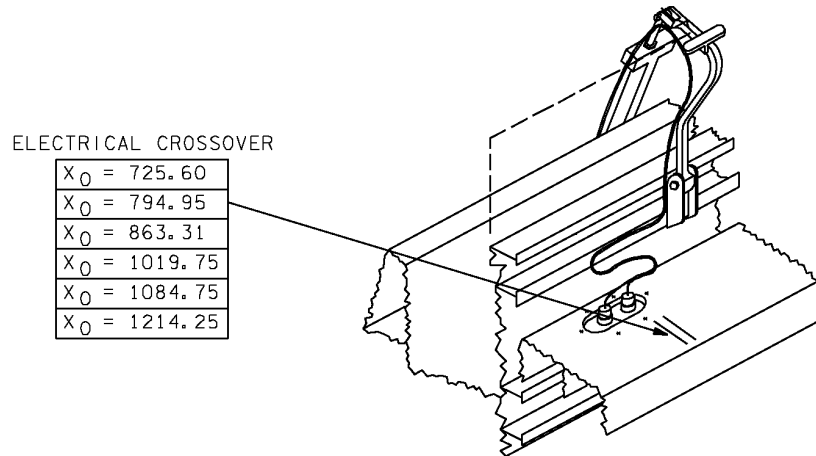
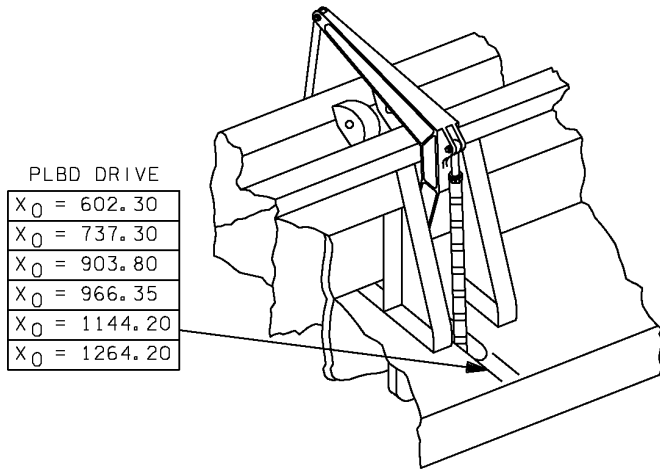
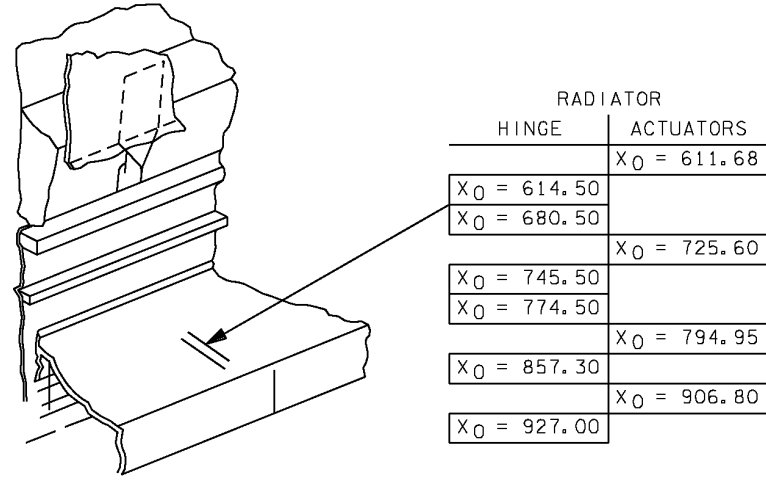
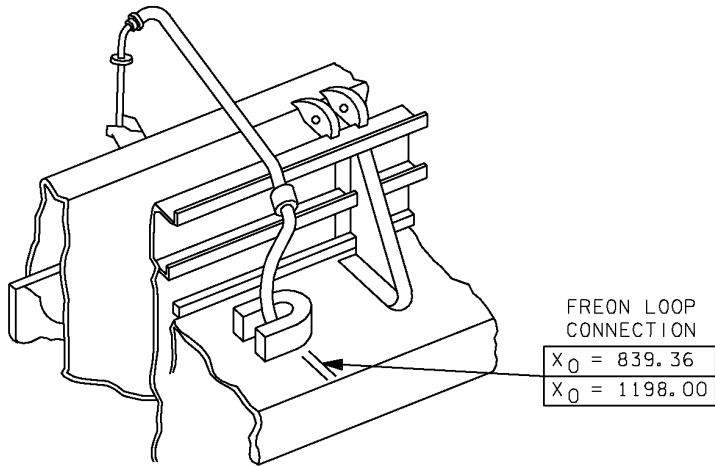

9466. ART 1

## RMS/PRLA CONTINGENCY EVA

### FOR RMS/PRLA FAILURES:

<u>PRE EVA RMS CONFIG</u> [1]	
IV	If MRL fails to latch:
A8L	√RMS R-F-L tb (three) – gray √RMS tb – STO Go to RMS TIEDOWN [4]
A8L	If MPM fails to stow(deploy): √RMS RETEN LAT – LAT (tb-LAT) √MPMs stowed(deployed) as far as possible Go to MPM STOW/DEPLOY [5]
	If Joint fails: Position RMS for easy striker bar access Go to RMS JOINT ALIGN [6]

<u>PRE EVA EE/GF CONFIG</u> [2]	
IV	A8U BRAKES – ON (tb-ON) EE MODE – OFF
A8L	RMS SEL – OFF Go to RMS FLIGHT RELEASABLE GRAPPLE FIXTURE RELEASE [8]

<u>PRE EVA PRLA CONFIG</u> [3]	
IV	MA73C:C cb MCA PWR AC1 3Φ MID 1 – op :D AC2 3Φ MID 3 – op
R13L	PL BAY MECH PWR 1,2 (two) – OFF
A6U	PL RETEN LOGIC PWR SYS 1,2 (two) – OFF LAT (five) – OFF Go to PRLA OPEN/CLOSE [9]

## RMS/PRLA CONTINGENCY EVA (Cont)

FOR RMS/PRLA FAILURES (Cont):

### RMS TIEDOWN 4

IV If MRL fail to latch – monitor EV1 and EV2

Refer to RMS TIEDOWN figure, following page, as reqd

#### RMS TIEDOWN

TOOL BOX – PRDs (2), EVA TRASH BAG

IFM – 9/64-in ALLEN WRENCH (AW)

ELBOW – PRD aft of MPM, peel blanket (fwd of MPM) toward EE; feed hook under cable harness (if reqd, remove cable harness clamp bolt with AW, bend clamp out of way), adjust strap as far fwd as possible

WRIST – PRD aft of MPM, strap rests just fwd of pitch joint opening

END EFFECTOR – PRD fwd of MPM, peel blankets aft and fwd, strap rests aft-most on yaw joint (at roll/yaw I/F), adjust strap under bolt studs

1. Figure eight the strap
2. Pull minimum 6-in slack in strap
3. Ratchet PRD snug, (14 full strokes reqd)
4. ✓Strap in correct arm location, ratchet tight
5. Reattach blankets

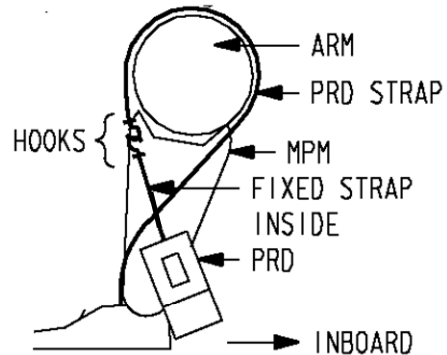

NOT IN EV CUFF

41

03/20/06

### MPM STOW/DEPLOY 5

IV1 If MPM fail to stow/deploy, monitor EV1 and EV2, then:

#### MPM STOW/DEPLOY

TOOL BOX – MPM WRENCH

1. Rotate torque shaft (8 revs) until MPMs are stowed/deployed,  $X_0=693$

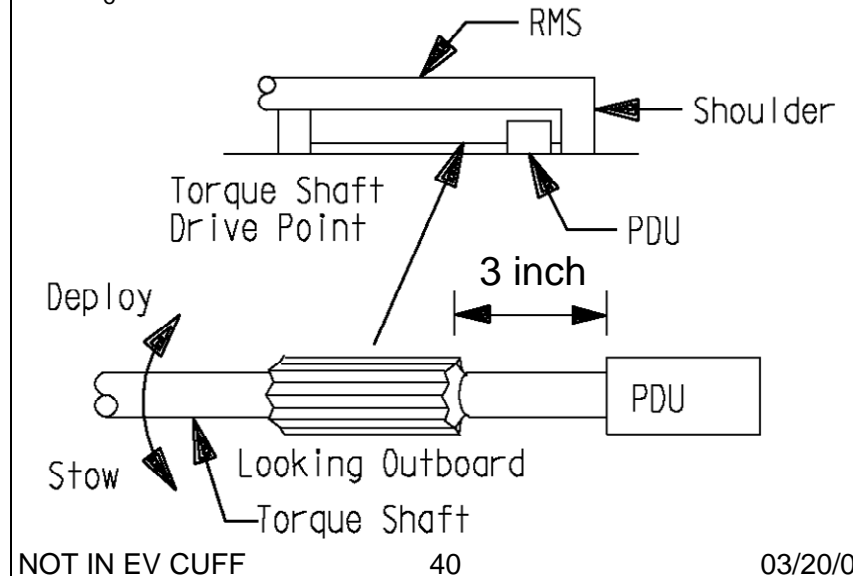

IV

A8L

When MPMs in stow(deploy) position:

✓RMS tb – STO(DPY)

or

4: SM 94 PDRS CONTROL

✓RMS STO/DPY

11 00 (00 11)



**RMS/PRLA CONTINGENCY EVA (Cont)**

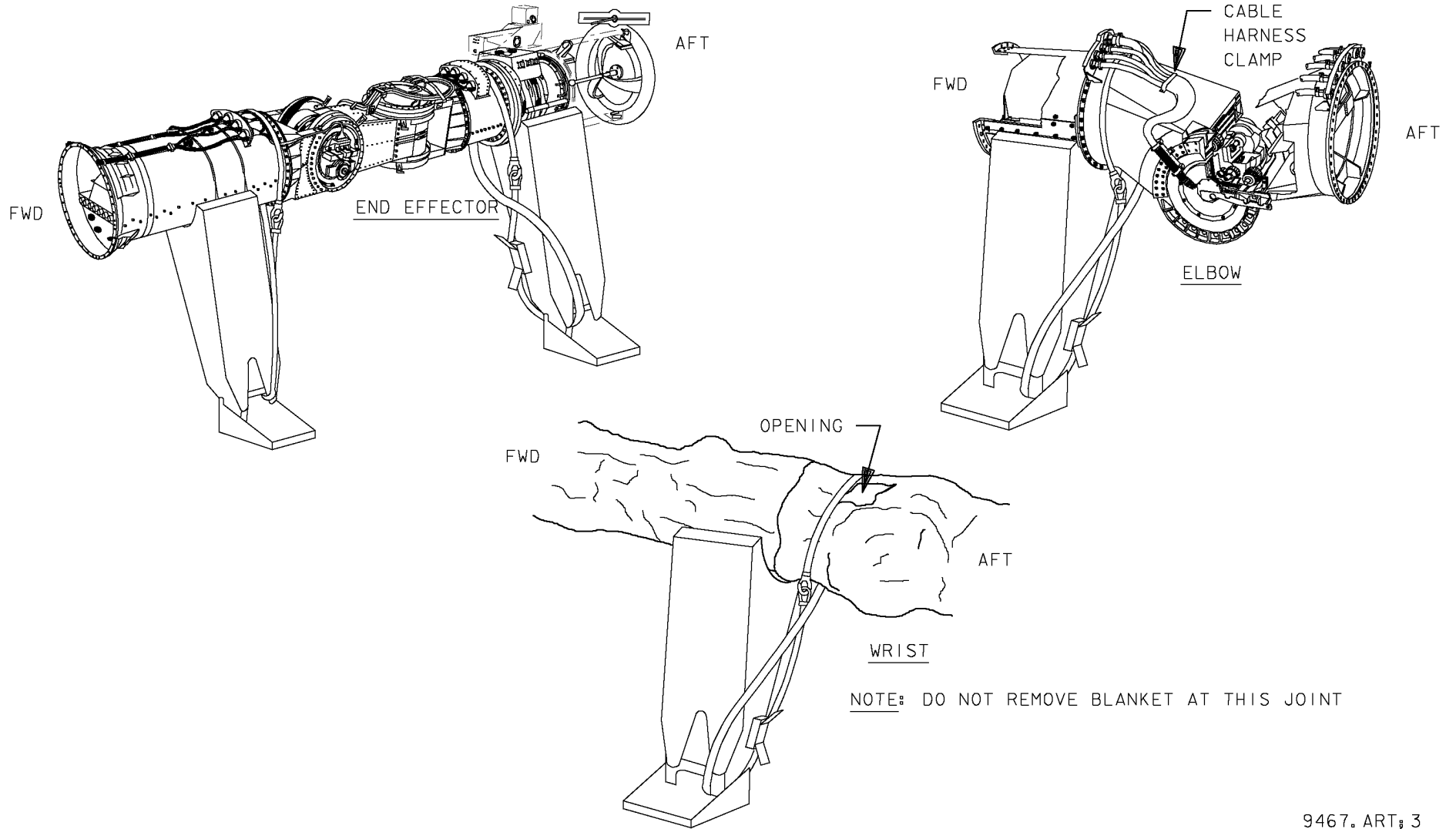

**RMS TIEDOWN**

## RMS/PRLA CONTINGENCY EVA (Cont)

### FOR RMS/PRLA FAILURES (Cont):

<b>RMS JOINT ALIGN</b> <span style="border: 1px solid black; padding: 2px;">6</span>	
IV	If Joint Fail – reposition RMS as reqd for RMS rope attachment – monitor EV1 and EV2
<b>RMS JOINT ALIGN</b>	
TOOL BOX – ADJ TETHERS, SNATCH BLOCKS (2), RMS ROPE REEL	
	1. Attach RMS rope around end effector under handrail. Translate to avoid wrapping rope around RMS
	2. Attach snatch block(s) to handrail(s) and route rope as reqd
IV	3. Reposition RMS as required for cradling
	4. Pull RMS down into MPMs
	5. Perform final positioning by hand to allow MRLs to latch
~ ~ ~	
	NOT IN EV CUFF <span style="margin-left: 100px;">39</span> <span style="float: right;">03/20/06</span>
IV	When RMS ready to latch:
R13L	PL BAY MECH PWR SYS (two) – ON
A8L	RMS RETEN LAT – LAT (tb-LAT 18 sec max) – OFF
	If MPMs deployed:
	√Elbow Camr in aligned posn:
	Pan 90° from X-AXIS
	Tilt per DECAL
A8L	RMS – STO (tb-STO, 68 sec max) – OFF
A8U	BRAKES – ON (tb-ON)
R13L	PL BAY MECH PWR SYS (two) – OFF

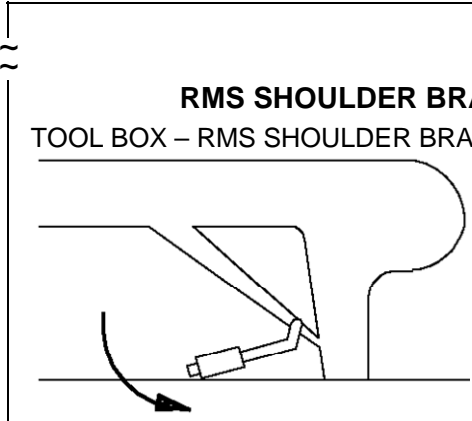
<b>RMS SHOULDER BRACE RELEASE</b> <span style="border: 1px solid black; padding: 2px;">7</span>	
IV	A8      √RMS SELECT – OFF
<b>RMS SHOULDER BRACE RELEASE</b>	
TOOL BOX – RMS SHOULDER BRACE RELEASE TOOL	
	1. Fold aside rub strip and thermal blankets
	2. Insert tool and move handle down
	3. Remove tool and reconfigure blankets
~ ~ ~	
	
NOT IN EV CUFF <span style="margin-left: 100px;">39</span> <span style="float: right;">03/20/06</span>	

## RMS/PRLA CONTINGENCY EVA (Cont)

FOR RMS/PRLA FAILURES (Cont):

### RMS FLIGHT RELEASABLE GRAPPLE FIXTURE RELEASE 8

#### **RMS FLIGHT RELEASABLE GRAPPLE FIXTURE RELEASE**

AIRLOCK – JETTISON STOWAGE BAG  
TOOL BOX – 1/2-in BOX RATCHET, VELCRO/TAPE

- EV**
1. Rotate 10 o'clock posn release rod ccw to hard stop (~36 strokes of 90 deg)
  2. Rotate 4 o'clock posn release rod cw to hard stop (~36 strokes of 90 deg – shaft will release from grapple fixture)
  3. Clear worksite for RMS powerdown
  4. Tape end of shaft to restrain slug within shaft
  5. Cover end effector with jettison stowage bag to restrain grapple shaft

NOT IN EV CUFF

42

12/19/07

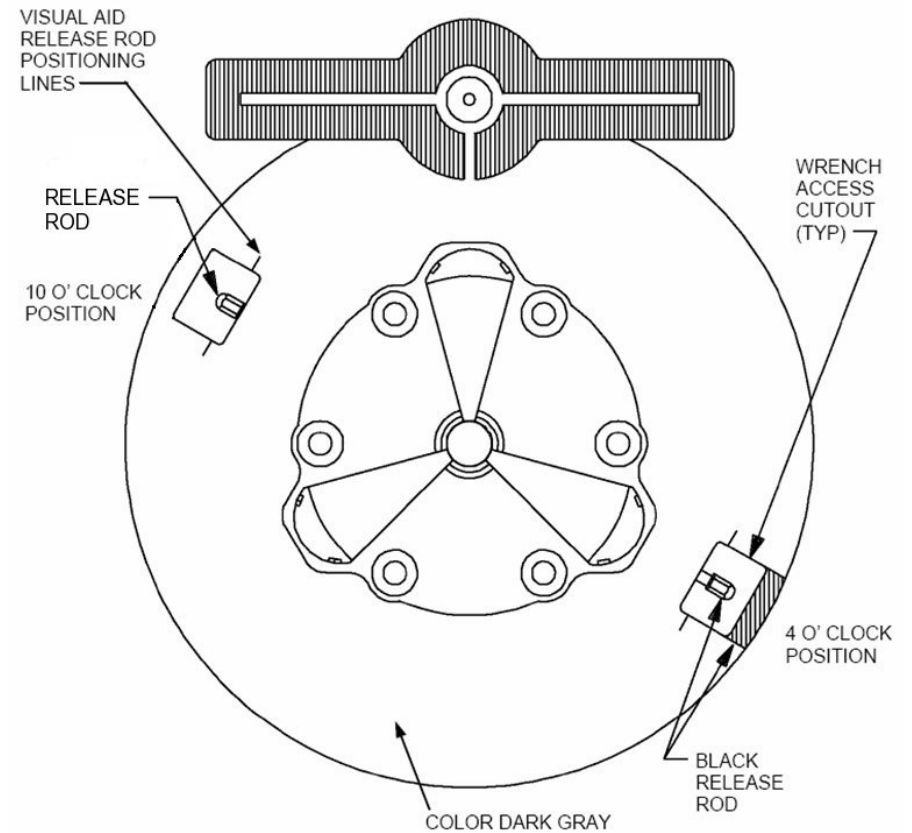

## RMS/PRLA CONTINGENCY EVA (Cont)

### EFGF GRAPPLE SHAFT RELEASE

Tools Reqd:  
1/2-in Box Ratchet, EVA Probe (PSA),  
Jettison Stowage Bag (Airlock),  
Spare Grapple Shaft w/Transfer Bag  
(if reqd, Airlock)

- EV
1. Perform visual inspection of EE/GF interface to determine possible cause of failure
  2. Remove tee pull (~10 lb)
  3. Rotate release rod cw (break out < 20 ft-lb, running < 11 ft-lb) to hard stop (~90 strokes of 70 deg)

**WARNING**  
If payload not restrained, rotation of release rod after grapple shaft release may impart movements to payload

- IV  
EV
4. ✓ Electrical connector disconnected
  5. If electrical connector not disconnected, insert probe into connector release port ~5.25 in for full release
- IV  
EV
6. Clear worksite for RMS cradle
  7. Perform RMS POWERDOWN (PDRS OPS)
  8. Cover end effector with jettison stowage bag to restrain grapple shaft

### SPARE SHAFT REPLACEMENT (If reqd)

- EV
9. Rotate release rod cw to hardstop then rotate ccw five strokes of ~70 deg (at least one full rev reqd). This will insure that grapple shaft can be released for future failures
  10. Insert spare shaft (~5 lb to overcome ball detent) using alignment pin and guide
  11. Rotate release rod ccw to hardstop (~90 strokes of ~70 deg), apply slight axial pressure to grapple shaft for initial rotations. This is required to aid in engagement of Acme threads  
  
If grapple shaft not engaged after four revs of release rod, repeat steps 9-11
  12. Verify no gap between grapple shaft shoulder and grapple fixture cone. If gap is visible, release shaft and repeat insertion procedures
  13. Replace tee pull

# RMS/PRLA CONTINGENCY EVA (Cont)

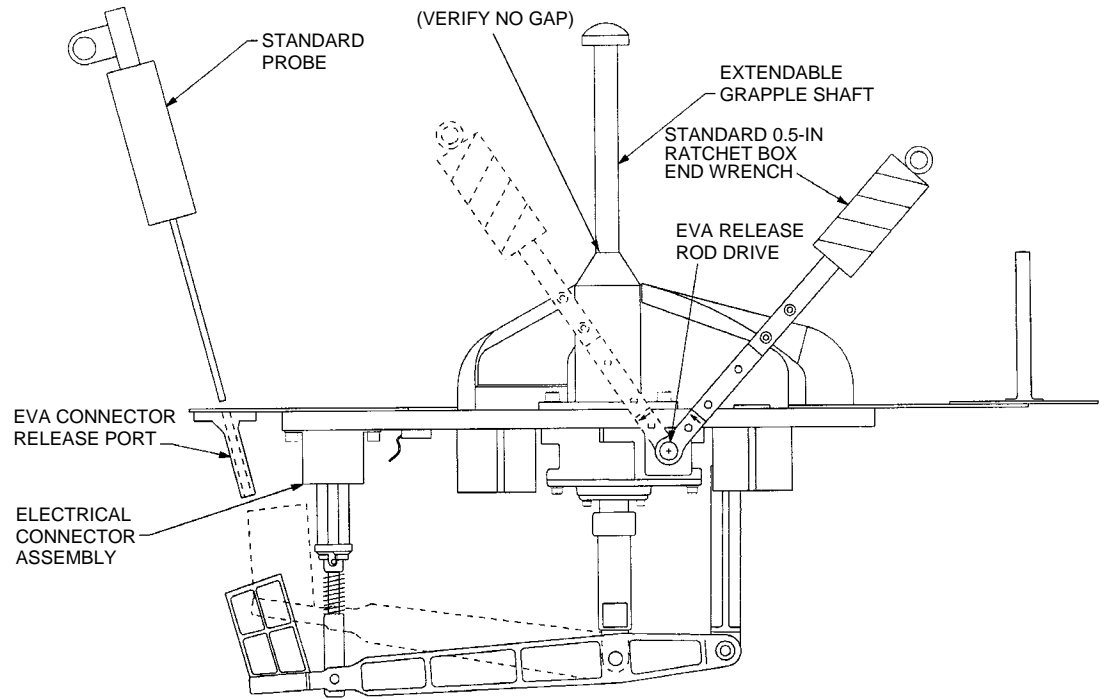
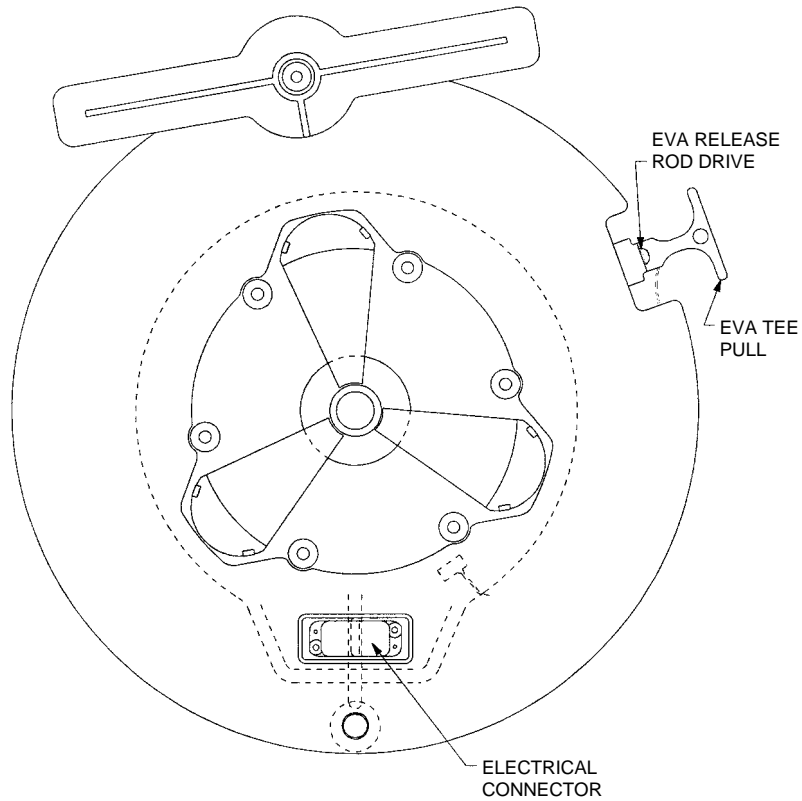

**ELECTRICAL FLIGHT GRAPPLE FIXTURE**

## RMS/PRLA CONTINGENCY EVA (Cont)

FOR RMS/PRLA FAILURES (Cont):

### PRLA OPEN/CLOSE 9

Refer to EVA RELEASABLE PAYLOAD RETENTION LATCHES figures, 14-11, 14-12, as reqd

#### **PRLA OPEN/CLOSE**

AIRLOCK – RATCHET WITH 7/16 SOCKET

**IV**   √PRLA PWR OFF

- EV**
1. Rotate ratchet in release direction (as marked above EVA drive) to shear pin
  2. View yellow indicator as applicable
  3. Continue to rotate drive 4-1/2 revs to disc gear train from drive shaft

To open latch:

4. Continue rotation in release direction (as marked above EVA drive) until latch open against stop

To close latch:

5. Rotate EVA drive in opposite direction of release (as marked above EVA drive) until latch closed against hardstop and over center

**IV**   √PRLA tb LAT

Cont next page

NOT IN EV CUFF

43

03/20/06

#### **PRLA OPEN/CLOSE (CONT)**

- EV**   6. Apply PRLA locking feature if applicable

To lock:

7. Rotate each bolt (two) cw 1/2 turn

For subsequent PRLA ops, release locking feature before operating EVA drive (two bolts ccw 1/2 turn); relock after operation

NOT IN EV CUFF

44

03/20/06

**IV**   MA73C:C   cb MCA PWR AC1 3Φ MID 1 – cl  
           :D   AC2 3Φ MID 3 – cl

To verify PL Latches op/cl:

A6U                   √PL RETEN LAT 1(2,3,4,5) tb – LAT(REL)

### POST EVA RMS CONFIG 10

**IV**

A8U

√BRAKES – ON (tb-ON)

Complete RMS POWERDOWN (PDRS OPS)

**RMS/PRLA CONTINGENCY EVA (Cont)**

In-board end of shaft has yellow marks.  
Not aligned indicates motor disengaged

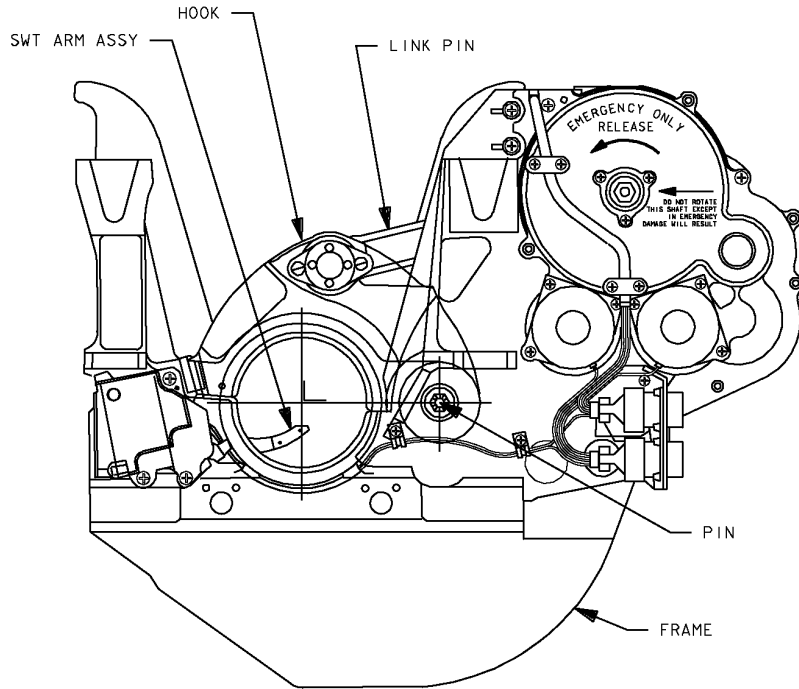

LWLL/MWLL/SMWLL

LIGHTWEIGHT LONGERON LATCH/  
MIDDLEWEIGHT LONGERON LATCH/  
SUPER MIDDLEWEIGHT LONGERON LATCH

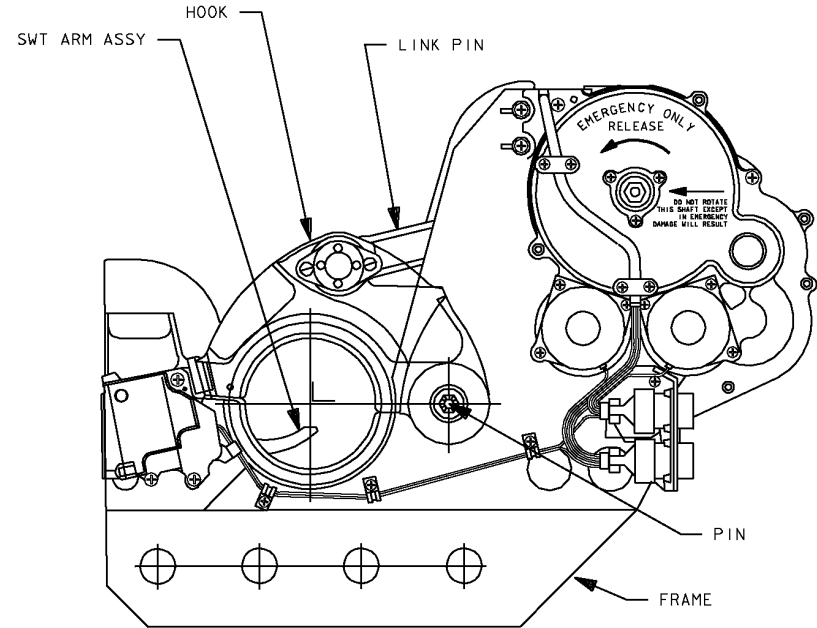

MMWL

MODIFIED MIDDLEWEIGHT LATCH

173253111. ART. 1

**EVA RELEASABLE PAYLOAD RETENTION LATCHES**

RMS/PRLA CONTINGENCY EVA (Cont)

In-board end of shaft extends to show yellow stripe when motor disengaged

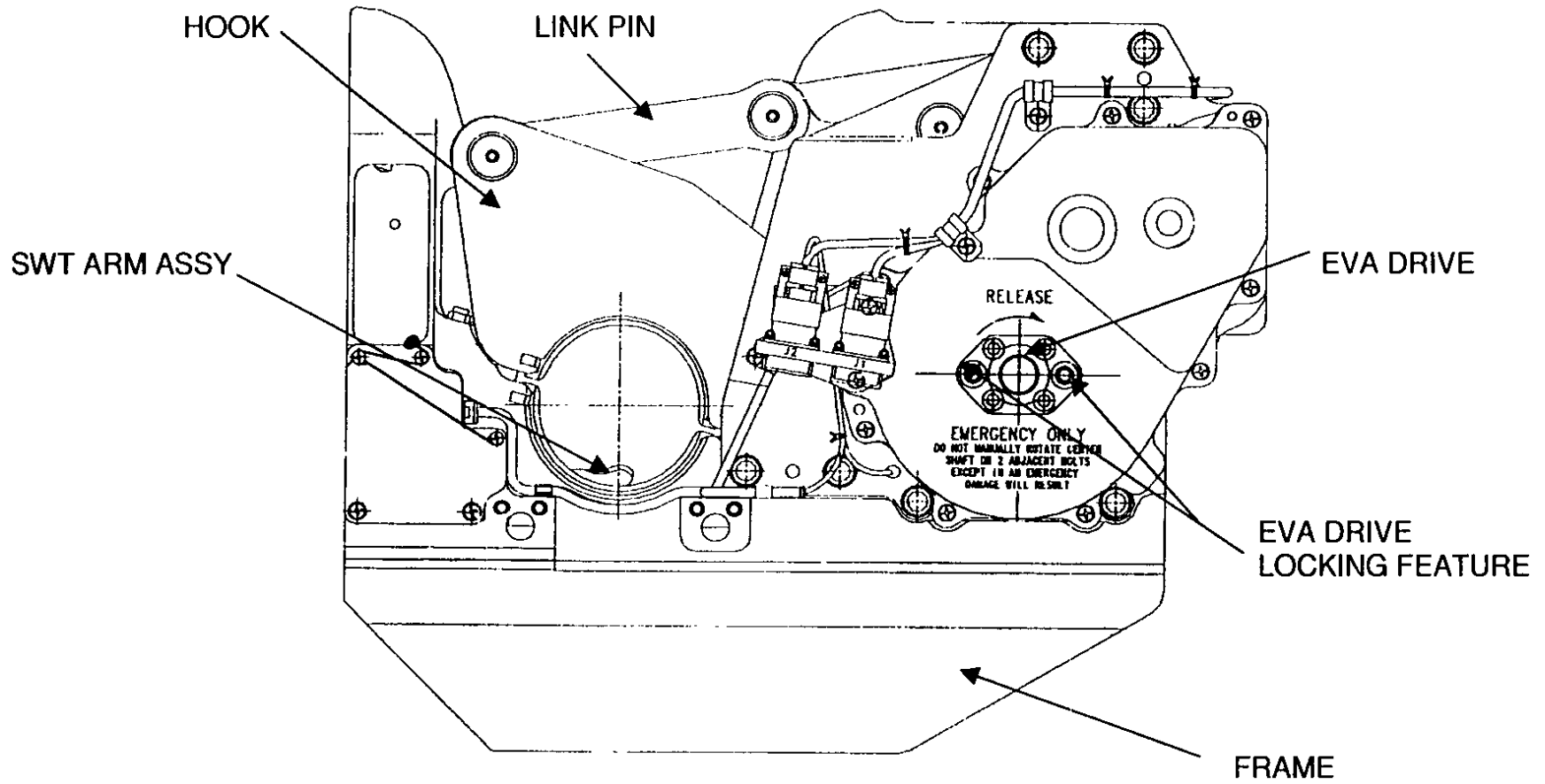

STANDARD WEIGHT LATCH

EVA RELEASABLE PAYLOAD RETENTION LATCHES (Cont)



## 96 BOLT PRE-EVA TOOL CONFIG

### STOWAGE LOCATIONS AT LAUNCH

Flight specific Middeck stowage and PFR configuration will be uplinked

EMUs:	Node Bag:	Configure Crewlock EVA Bag:
MWS Baseplates (2)	96 Bolt Bag:	PGT Spare Battery
Retractable Tethers (2)	7/16-in Box End Wrenches (2)	Socket Caddies w/6-in Exts (2), RAD (Spare)
Adj Equip Tethers (2)	ODS Clamps (2)	
Waist Tethers (4)	ODS Clamp Handles (2)	Configure Adj Fuse Tether with one of following:
	PB Articulating Socket	GP Caddies (2)
Middeck:	Bridge Rail Clamp	PGTs w/Batteries (2)
MWS T-bars (2)	RAD w/7/16-in Sockets (2)	
MWS Swing Arms (3)		
BRT (2)	TSA (Port):	
Waist Tethers Ext (2) (If flown)	Large Cutter	Stow Adj Fuse Tether, Crewlock Bag, Jettison
General Purpose (GP) Caddies (2)	PRDs (2)	Stowage Bag in Airlock pre-EVA
Adj Equip Tethers (2)	Sm EVA Trash Bags (2)	
Retractable Tethers (2)		
Crewlock Bag	Fwd Bulkhead:	
Right Angle Drive (RAD)	PFR	Remove ODS Centerline Camera pre-EVA
Socket Caddy		
6-in Exts (2)	Port PLB (Bay 2):	
PGTs (2)	Bridge Rail Clamp	
PGT Batteries (3)	PB Articulating Socket	
Adj Fuse Tether		
Jettison Stowage Bag		

## 96 BOLT EVA TIMELINE

PET	IV/RMS	EV1	EV2
-40:00	√DOCKING MECHANISM POWERDOWN (RNDZ, APDS) before start of DEPRESS		
	ML86B:D 1. cb MNA MMU GN2 SPLY ISOL VLV A – cl		
	R13L 2. MMU GN2 SPLY ISOL VLV A – CL (tb-CL)		
-00:25	ML86B:D 3. cb MNA MMU GN2 SPLY ISOL VLV A – op	1. Perform DEPRESS ( <u>DEPRESS/REPRESS</u> )	2. Perform DEPRESS ( <u>DEPRESS/REPRESS</u> )
-00:20	Confirm TCS powerdown		
00:00	MET at PWR – BATT _____/_____:____	3. Perform POST DEPRESS ( <u>DEPRESS/REPRESS</u> )	4. Perform POST DEPRESS ( <u>DEPRESS/REPRESS</u> )
00:15		5. Perform <u>AIRLOCK EGRESS</u> (CUFF C/L, 47) Add the following steps to AIRLOCK EGRESS:	6. Perform <u>AIRLOCK EGRESS</u> (CUFF C/L, 47) Add the following steps to AIRLOCK EGRESS:
00:30		6a. Translate to GO2 ISOLATION VALVE on outside of airlock (aft port side)	
	AW64L(E)	6b. Open thermal cover; remove PIP pin	
		6c. GO2 XFER ISO VLV – CL AW64L(E)	
		6d. Re-install PIP pin; close thermal cover	
	GN2 XFER PANEL GO2 XFER PANEL		6e. √ODS hatch ΔP < 0.5
			6f. Open ODS Hatch per decal
			6g. Remove docking lights (two): Release elec connector (one) at each light PIP pin (one) on each light boom; stow in bag
			6h. Remove Cross-Hair assembly; stow in bag
			6i. VENT – OP; FLOW – OP GN2 XFER PANEL
			6j. VENT – OP; FLOW – OP GO2 XFER PANEL
			6k. √Pressure gauges (two) – zero
			6l. Close ODS hatch per decal
			6m. √ODS Equal vlvs (two) capped

## 96 BOLT EVA TIMELINE (Cont)

PET	IV/RMS	EV1	EV2
<p>01:00</p> <p>01:20</p> <p>01:45</p>	<p>PGT: 25.5 ft-lb, CCW2, 30.5</p>	<p><u>PAYLOAD BAY SETUP</u></p> <ol style="list-style-type: none"> <li>1. Retrieve 96 Bolt Bag from Node Bag</li> <li>2. Attach 96 Bolt Bag to Ext A/L Truss near port TSA</li> <li>3. Remove thermal blanket covering ODS bolts; temp stow in A/L with Adj Equip Tether</li> <li>4. Retrieve GP Caddy from Adj Fuse Tether; attach to MWS</li> </ol> <p><u>TOOL CONFIG</u></p> <ol style="list-style-type: none"> <li>1. Retrieve Right Angle Drives from 96 Bolt Bag and meet EV2 at Adj Fuse Tether</li> <li>2. Retrieve ODS Clamp and Handle from 96 Bolt Bag; install handle in clamp, √locked; hand off to EV2</li> <li>3. Retrieve ODS Clamp and Handle from 96 Bolt Bag; install handle in clamp; √locked; attach Waist Tether from EMU to ODS Clamp</li> <li>4. Retrieve 7/16-in Box End Wrench from 96 Bolt Bag; attach to GP Caddy</li> </ol> <div data-bbox="657 1047 1232 1133" style="border: 1px solid black; padding: 5px; text-align: center;"> <p><b>CAUTION</b> During clamp installation, do not apply any sideload on ODS gusset (may puncture A/L)</p> </div> <p><u>INSTALL CLAMP – STBD</u></p> <ol style="list-style-type: none"> <li>1. Tether ODS Clamp to handrail at worksite</li> <li>2. Release bolts 35 to 38 (four); pull to lock up</li> <li>3. Retract Clamp pip pin</li> <li>4. Install clamp between bolts 36,37</li> <li>5. Set clamp Turn bolt at top of clamp until upper jaws contact vestibule ring, then add'l 3/4 turn; insert pip pin</li> <li>6. √Clamp Handle locked</li> </ol>	<p><u>PAYLOAD BAY SETUP</u></p> <ol style="list-style-type: none"> <li>1. Retrieve following items from port TSA: PRDs (2) Large Cutter</li> <li>2. Close and latch TSA door</li> <li>3. Temp stow PRDs (two) on Truss</li> <li>4. Temp stow Large Cutter on stbd ODS using Adj Equip Tether</li> <li>5. Retrieve Adj Fuse Tether from A/L; temp stow on Truss</li> <li>6. Remove thermal blanket covering ODS bolts; temp stow in A/L with Adj Equip Tether</li> <li>7. Retrieve GP Caddy from Adj Fuse Tether; attach to MWS</li> </ol> <p><u>TOOL CONFIG</u></p> <ol style="list-style-type: none"> <li>1. Translate to Adj Fuse Tether, wait for EV1</li> <li>2. Configure PGTs (two) with Right Angle Drives using RET w/pip pin or pip pin in 96 Bolt Bag</li> <li>3. Retrieve ODS Clamp from EV1, attach Waist Tether from EMU to ODS Clamp</li> <li>4. Retrieve 7/16-in Box End Wrench from 96 Bolt Bag; attach to GP Caddy</li> </ol> <div data-bbox="1346 1047 1921 1133" style="border: 1px solid black; padding: 5px; text-align: center;"> <p><b>CAUTION</b> During clamp installation, do not apply any sideload on ODS gusset (may puncture A/L)</p> </div> <p><u>INSTALL CLAMP – PORT</u></p> <ol style="list-style-type: none"> <li>1. Tether ODS Clamp to handrail at worksite</li> <li>2. Release bolts 83 to 86 (four); pull to lock up</li> <li>3. Retract Clamp pip pin</li> <li>4. Install clamp between bolts 84,85</li> <li>5. Set clamp Turn bolt at top of clamp until upper jaws contact vestibule ring, then add'l 3/4 turn; insert pip pin</li> <li>6. √Clamp Handle locked</li> </ol>

**96 BOLT EVA TIMELINE (Cont)**

PET	IV/RMS	EV1	EV2
02:05	Record Cables cut at following locations: Bolt 32 – 1 cable _____ Bolt 24 – 7 cables _____ Bolt 21 – 1 cable _____ Bolt 19 – 1 cable _____ Bolt 1 – 1 cable _____ Bolt 95 – 2 cables _____ Bolt 74 – 2 cables _____ Bolt 69 – 3 cables _____ Line 69 – 1 line N2 _____ Line 66 – 1 line O2 _____ Bolt 51 – 1 cable _____ Bolt 47 – 2 cables _____  PGT: 25.5 ft-lb, CCW2, 30.5	<p><u>IF PFR REQUIRED:</u></p> <ol style="list-style-type: none"> <li>1. Retrieve Art Socket and Bridge Rail Clamp from 96 Bolt Bag</li> <li>2. Install bridge rail clamp and art socket on stbd bridge rail in aft-most available half-hole, knob inboard</li> <li>3. Retrieve PFR from port side</li> </ol> <p><u>PFR SETUP FOR CLAMP INSTALL</u></p> <ol style="list-style-type: none"> <li>1. Art Socket: P = 2, Y = 6</li> <li>2. PFR: P = 10, R = A, Y = 8</li> </ol> <div data-bbox="695 634 1199 740" style="border: 2px solid black; padding: 5px; text-align: center;"> <p><u>WARNING</u> Cut ends of O2 and N2 lines present sharp edge hazard</p> </div>	<p><u>IF PFR REQUIRED:</u></p> <p>Port Bridge Rail Clamp and Art Socket launched in second to fwd-most available half-hole</p> <ol style="list-style-type: none"> <li>1. Move clamp assy to fwd-most available half-hole, knob inboard</li> <li>2. Retrieve fwd bulkhead PFR and install</li> </ol> <p><u>PFR SETUP FOR CLAMP INSTALL</u></p> <ol style="list-style-type: none"> <li>1. Art Socket: P = 1, Y = 6</li> <li>2. PFR: P = 10.5, R = A, Y = 3</li> </ol> <div data-bbox="1388 634 1892 740" style="border: 2px solid black; padding: 5px; text-align: center;"> <p><u>WARNING</u> Cut ends of O2 and N2 lines present sharp edge hazard</p> </div> <p><u>CUT CABLES AND LINES</u></p> <ol style="list-style-type: none"> <li>1. Use Large Cutter to cut all cables at 96 bolt interface</li> <li>2. Bend cables w/cutter to verify cables separated</li> <li>3. Cut O2 and N2 lines</li> <li>4. Stow Large Cutter on available handrail</li> </ol>
03:15		<p><u>USE BRT FOR BOLT RELEASE</u></p> <ol style="list-style-type: none"> <li>1. Release bolts 1-33, 40-48 and grounding strap between bolts 9 and 10</li> </ol> <p><u>SURVEY VESTIBULE</u></p> <ol style="list-style-type: none"> <li>1. ✓All bolts except 34,39,82,87 locked up</li> <li>2. ✓All cables cut (21), all gas lines cut (two), and ground strap removed</li> <li>3. ✓All tools, tethers removed from vestibule</li> <li>4. ✓Separation plane clear of all cables and lines</li> </ol>	<p><u>USE BRT FOR BOLT RELEASE</u></p> <ol style="list-style-type: none"> <li>1. Release bolts 49-81, 88-96</li> </ol> <p><u>SURVEY VESTIBULE</u></p> <ol style="list-style-type: none"> <li>1. ✓All bolts except 34,39,82,87 locked up</li> <li>2. ✓All cables cut (21), all gas lines cut (two), and ground strap removed</li> <li>3. ✓All tools, tethers removed from vestibule</li> <li>4. ✓Separation plane clear of all cables and lines</li> </ol>

**96 BOLT EVA TIMELINE (Cont)**

PET	IV/RMS	EV1	EV2						
<p>03:25</p> <p>03:50</p> <p>04:00</p> <p>04:05</p>	<p>√FREE DRIFT PGT: 25.5 ft-lb, CCW2, 30.5</p> <p>Give EV GO for Clamp Release</p> <p>SEPARATION BURN</p>	<p><u>PREP FOR RELEASE</u></p> <ol style="list-style-type: none"> <li>1. Receive PRD from temp stow on Truss</li> <li>2. Attach PRD fixed end to handrail, retractable end to Clamp Handle</li> <li>3. Before releasing last two bolts, √FREE DRIFT</li> <li>4. Release bolts 34,39; pull to lock up</li> <li>5. Notify IV, GO for Clamp Release</li> </ol> <p><u>CLAMP RELEASE</u></p> <ol style="list-style-type: none"> <li>1. Retract Clamp Handle pip pin; √green stripe visible</li> </ol> <table border="1" data-bbox="655 678 1239 797"> <tr> <td style="text-align: center;"><u>CAUTION</u></td> </tr> <tr> <td>Posn body below separation plane for clamp release</td> </tr> <tr> <td>During clamp release, do not apply any sideload on ODS gusset (may puncture A/L)</td> </tr> </table> <ol style="list-style-type: none"> <li>2. Coordinate with IV and give EV2 short count for simo release</li> <li>3. Simo with EV2, pull on PRD strap to open clamp</li> <li>4. After clamp open, inform IV, "Clamp open and EV1 clear"</li> </ol> <p><u>CLEANUP</u></p> <ol style="list-style-type: none"> <li>1. Translate to TSA w/96 Bolt Bag Remove Right Angle Drives (two) from PGTs (two) using pip pin on 96 Bolt Bag; stow in 96 Bolt Bag</li> <li>2. Remove ODS Clamp and Handle from ODS gusset; stow Clamp, Handle, 7/16-in Box End Wrench in 96 Bolt Bag</li> <li>3. Stow Waist Tether on EMU</li> <li>4. Remove and stow 96 Bolt Bag in airlock</li> <li>5. Stow PRD, Trash Bag in Port TSA</li> </ol> <p>IF USED:</p> <ol style="list-style-type: none"> <li>6. Configure stbd PFR assy for landing: Bridge Rail Clamp: second to aft-most available half-hole; √knob locked</li> <li>7. Art Socket: P = 11.5, Y = 3; √locked</li> <li>8. PFR to EV2 port side</li> </ol>	<u>CAUTION</u>	Posn body below separation plane for clamp release	During clamp release, do not apply any sideload on ODS gusset (may puncture A/L)	<p><u>PREP FOR RELEASE</u></p> <ol style="list-style-type: none"> <li>1. Receive PRD from temp stow on Truss</li> <li>2. Attach PRD fixed end to handrail, retractable end to Clamp Handle</li> <li>3. Before releasing last two bolts, √FREE DRIFT</li> <li>4. Release bolts 82,87; pull to lock up</li> <li>5. Notify IV, GO for Clamp Release</li> </ol> <p><u>CLAMP RELEASE</u></p> <ol style="list-style-type: none"> <li>1. Retract Clamp Handle pip pin; √green stripe visible</li> </ol> <table border="1" data-bbox="1348 678 1932 797"> <tr> <td style="text-align: center;"><u>CAUTION</u></td> </tr> <tr> <td>Posn body below separation plane for clamp release</td> </tr> <tr> <td>During clamp release, do not apply any sideload on ODS gusset (may puncture A/L)</td> </tr> </table> <ol style="list-style-type: none"> <li>2. Simo with EV1, pull on PRD strap to open clamp</li> <li>3. After clamp open, inform IV, "Clamp open and EV2 clear"</li> </ol> <p><u>CLEANUP</u></p> <ol style="list-style-type: none"> <li>1. Translate to TSA</li> <li>2. Stow PGTs (two) on Adj Fuse Tether</li> <li>3. Stow Adj Fuse Tethers in airlock</li> <li>4. Remove ODS Clamp and Handle from ODS gusset; stow Clamp, Handle, 7/16-in Box End Wrench in 96 Bolt Bag</li> <li>5. Stow Waist Tether on EMU</li> <li>6. Stow Large Cutter, Trash Bag, PRD in Port TSA</li> <li>7. Close TSA door, close all latches</li> </ol> <p>IF USED:</p> <ol style="list-style-type: none"> <li>8. Configure port PFR socket assy for landing: Bridge Rail Clamp: second to fwd-most available half-hole; √knob locked</li> <li>9. Art Socket: P = 11.5, Y = 3; √locked</li> <li>10. PFR: P = 10, R = A, Y = 6; √locked</li> </ol>	<u>CAUTION</u>	Posn body below separation plane for clamp release	During clamp release, do not apply any sideload on ODS gusset (may puncture A/L)
<u>CAUTION</u>									
Posn body below separation plane for clamp release									
During clamp release, do not apply any sideload on ODS gusset (may puncture A/L)									
<u>CAUTION</u>									
Posn body below separation plane for clamp release									
During clamp release, do not apply any sideload on ODS gusset (may puncture A/L)									

**96 BOLT EVA TIMELINE (Cont)**

PET	IV/RMS	EV1	EV2
04:40		<u>VERIFY 96 BOLT BAG STOWAGE</u> ODS Clamps (2) ODS Clamp Handles (2) Right Angle Drives with 7/16-in Socket (2) 7/16-in Box End Wrenches (2)	<u>VERIFY AIRLOCK STOWAGE</u> Adj Fuse Tethers PGTs w/batteries (2) GP Caddies (2) ODS Thermal Blankets with Adj Equip Tethers (2) 96 Bolt Bag Crewlock Bag: PGT spare battery Socket Caddy w/6-in Exts (2), RAD
05:15		<u>PERFORM AIRLOCK INGRESS, CUFF C/L, 30</u> √EMU equipment: MWS w/swing arm BRT Retractable Tethers (2) Adj Equip Tethers (2) Waist Tethers (2)	<u>PERFORM AIRLOCK INGRESS, CUFF C/L, 30</u> √EMU equipment: MWS w/swing arm BRT Retractable Tethers (2) Adj Equip Tethers (2) Waist Tethers (2)
05:30			

## CAPTURE LATCH MANUAL RELEASE (ODS/PMA)

IV	EV
<p>A7 If APDS powered:            pb PWR OFF – push            √STATUS Lt (eighteen) – off            Perform DOCKING MECHANISM POWERDOWN            (RNDZ, <u>APDS</u>)</p> <p style="text-align: right;">Cont next page</p>	<div style="border: 1px solid black; padding: 5px; margin-bottom: 10px;"> <p style="text-align: center;"><b>TOOLS REQD</b></p> <p>Jettison Stowage Bag            Russian Capture Latch Tool (if reqd,            in Node Bag)</p> </div> <p>BOTH 1. Configure Waist Tethers as safety line inside ODS</p> <p>EV1 Attach at ODS Hatch D-ring nearest capture latches</p> <p>EV2 Attach at A/L D-ring behind EV1</p> <p>EV2 2. Open outer hatch to improve EMU sublimator performance</p> <p>EV1 3. ODS/PMA interface:            Open ODS hatch            Remove docking lights (two):                Release elec connector (one) at each light                pip pin (one) on each light boom                Stow lights and booms in bag</p> <p style="text-align: center;"><u>NOTE</u>            EV2 restrain/aid EV1 as reqd</p> <p>EV1 4. Remove Cross-Hair assembly            Stow in bag</p> <p>5. √IV GO for release</p> <p>6. Release capture latch</p> <p style="text-align: right;">Cont next page</p>

**CAPTURE LATCH MANUAL RELEASE (ODS/PMA) (Cont)**

IV	EV
	<p style="text-align: center;"><u>NOTE</u> If reqd, EV2 retrieve Russian Capture Latch Tool from Node Bag (requires safety tether reel ops)</p> <p>7. Notify IV when capture latch released</p> <p>8. Close hatch at capture latch interface</p> <p>EV2 9. If used, temp stow Russian Capture Tool in A/L and perform AIRLOCK INGRESS (CUFF C/L, 30)</p> <p>10. Close outer hatch</p> <p>BOTH 11. Go to A/L REPRESS</p>

I



# 96 BOLT EVA LAYOUT

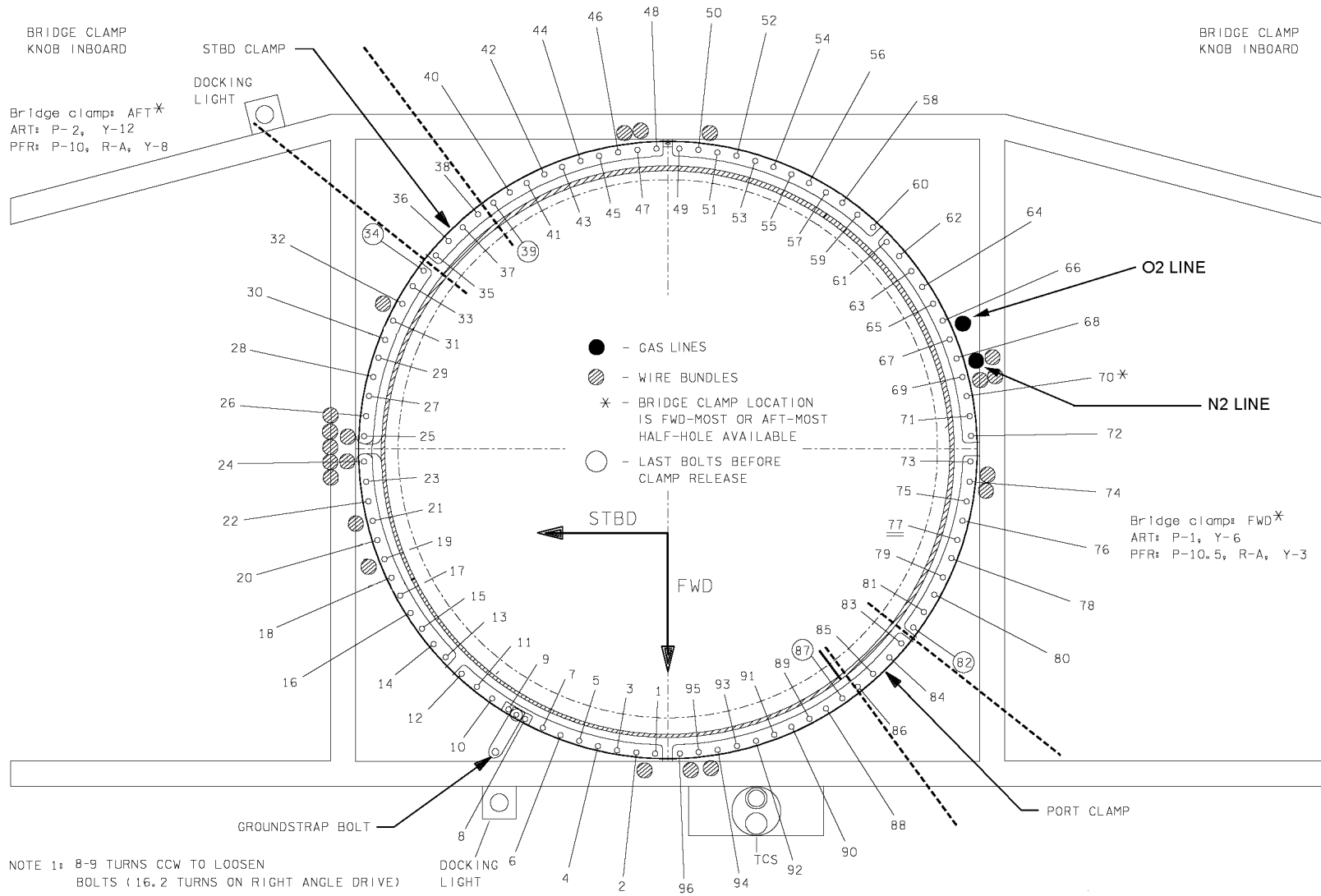

480240188. ART: 2

## PLBD LATCH TOOL PLACEMENT WITH DUAL LATCH GANG FAILURES

CASE*	FAILED GANG 1	FAILED GANG 2	Three Point Latch Tool Positions Cuff C/L, 37		Centerline Latch Tool Positions Cuff C/L, 38	
			FWD #2**	FWD #4**	-	-
A	Fwd Bulkhead Port	Fwd Bulkhead Stbd	FWD #2**	FWD #4**	-	-
B	Fwd Bulkhead Port	Centerline Fwd	FWD #2	FWD #4	CL #1	CL #2
C	Fwd Bulkhead Stbd	Centerline Fwd	FWD #2	FWD #4	CL #1	CL #2
D	Centerline Fwd	Centerline Mid Fwd	-	-	CL #5	CL #6
E	Centerline Mid Fwd	Centerline Mid Aft	-	-	CL #7	CL #8
<p>*Other combinations of Two-Gangs Out involve doors in the crush pressure zone (latches in compression) or have at least one closed gang between failed gangs (no tension loads bleeding between gangs, giving load distributions identical to single latch gang failures)</p> <p>**Install both 3-pt tools on same side (Port or Stbd)</p>						

EVA CUFF CHECKLIST

NORMAL EVA STATUS ..... 15-2  
DCM CONFIGURATION..... 15-2  
EMU MALFUNCTION INDEX ..... 15-2  
DECOMPRESSION SICKNESS (DCS) ..... 15-3  
DECOMPRESSION SICKNESS (DCS) (CONT) ..... 15-3  
ABORT EVA ..... 15-3  
TERMINATE EVA ..... 15-3  
SUIT P EMERG ..... 15-4  
SOP O2 ON ..... 15-4  
BATT AMPS HIGH..... 15-4  
BATT V DECAY OR BATT VDC LOW ..... 15-4  
SUIT P LOW ..... 15-5  
SUIT P HIGH ..... 15-5  
SOP P LOW ..... 15-5  
O2 USE HIGH..... 15-5  
SUBLM PRESS ..... 15-6  
H2O GP LOW ..... 15-6  
RESRV H2O ON..... 15-6  
H2O WP HIGH..... 15-6  
NO VENT FLOW..... 15-7  
CO2 HIGH OR MONITOR CO2 ..... 15-7  
CO2 SNSR BAD ..... 15-7  
COMM FAILURE ..... 15-7  
AIR FLOW CONTAMINATION ..... 15-8  
LOSS OF COOLING..... 15-8  
RLF V FAIL ..... 15-8  
MISC MSGS 1 ..... 15-8  
MISC MSGS (CONT)/TIME LF ..... 15-9  
AIRLOCK LATCH DISCONNECT..... 15-9  
AIRLOCK INGRESS..... 15-9

FOLLOWING PAGES NOT IN EV CUFF

RADIATOR ACTUATOR DISCONNECT ..... 15-9  
PLBD DRIVE CUT ..... 15-10  
DOOR DRIVE RESTRAINT ..... 15-10  
DOOR DRIVE DISCONNECT ..... 15-10  
WINCH OPERATIONS ..... 15-10  
WINCH OPERATIONS (CONT)..... 15-11  
3-PT TOOL INSTALLATION..... 15-11  
CL LATCH TOOL ..... 15-11  
RMS JOINT ALIGN..... 15-11  
MPM STOW/DEPLOY ..... 15-12  
RMS TIEDOWN ..... 15-12  
RMS FLIGHT RELEASABLE GRAPPLE FIXTURE RELEASE ..... 15-12  
PRLA OPEN/CLOSE ..... 15-12  
PRLA OPEN/CLOSE (CONT)..... 15-13  
KU ANTENNA STOW ..... 15-13  
KU ANTENNA STOW (CONT) ..... 15-13  
AIRLOCK EGRESS ..... 15-13

EVA CUFF C/L

# EVA CUFF C/L

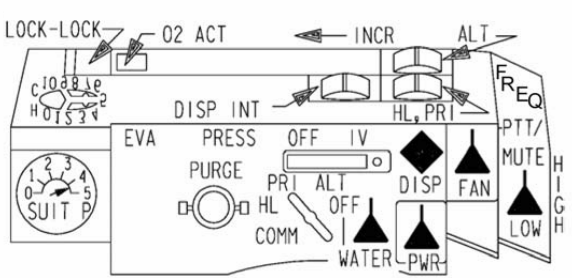
	<p style="text-align: center;"><b>NORMAL EVA STATUS</b></p> <table border="1"> <tr><td>O2 POS</td><td>EVA</td></tr> <tr><td>SUBLM P</td><td>2.0-4.2 psia</td></tr> <tr><td>TIME EV</td><td>HR:MIN since PWR-BATT</td></tr> <tr><td>TIME LF/limit consum</td><td>HR:MIN remaining at present use rate</td></tr> <tr><td>% O2 (PWR) LF</td><td>Non-limiting consumable will be displayed</td></tr> <tr><td>SUIT P</td><td>4.2-4.4 (4.7 during/after depress) psid</td></tr> <tr><td>O2 P</td><td>150-900 psia</td></tr> <tr><td>O2 RATE</td><td>0-4.0 psi/minute</td></tr> <tr><td>SOP P</td><td>5410-6800 psia</td></tr> <tr><td>BAT VDC</td><td>≥ 16.7</td></tr> <tr><td>BAT AMP</td><td>3.0-4.0</td></tr> <tr><td>RPM</td><td>18.0-20.0 K</td></tr> <tr><td>CO2</td><td>0.2-4.0 mm</td></tr> <tr><td>H2O TEMP</td><td>32-75 degF</td></tr> <tr><td>H2O GP</td><td>14.0-16.0 psid</td></tr> <tr><td>H2O WP</td><td>14.0-16.0 psid</td></tr> <tr><td>DATA?</td><td>COMBO</td></tr> <tr><td>BATT</td><td>32.0 AH (as directed by MCC-H)</td></tr> <tr><td>GAUGE</td><td>4.2-4.4 psid (4.7 during/after depress) psid</td></tr> </table> <p style="text-align: right;">1 <span style="float: right;">03/10/06</span></p>	O2 POS	EVA	SUBLM P	2.0-4.2 psia	TIME EV	HR:MIN since PWR-BATT	TIME LF/limit consum	HR:MIN remaining at present use rate	% O2 (PWR) LF	Non-limiting consumable will be displayed	SUIT P	4.2-4.4 (4.7 during/after depress) psid	O2 P	150-900 psia	O2 RATE	0-4.0 psi/minute	SOP P	5410-6800 psia	BAT VDC	≥ 16.7	BAT AMP	3.0-4.0	RPM	18.0-20.0 K	CO2	0.2-4.0 mm	H2O TEMP	32-75 degF	H2O GP	14.0-16.0 psid	H2O WP	14.0-16.0 psid	DATA?	COMBO	BATT	32.0 AH (as directed by MCC-H)	GAUGE	4.2-4.4 psid (4.7 during/after depress) psid	<p><b>DCM CONFG INDEX</b></p>																																																						
O2 POS	EVA																																																																																													
SUBLM P	2.0-4.2 psia																																																																																													
TIME EV	HR:MIN since PWR-BATT																																																																																													
TIME LF/limit consum	HR:MIN remaining at present use rate																																																																																													
% O2 (PWR) LF	Non-limiting consumable will be displayed																																																																																													
SUIT P	4.2-4.4 (4.7 during/after depress) psid																																																																																													
O2 P	150-900 psia																																																																																													
O2 RATE	0-4.0 psi/minute																																																																																													
SOP P	5410-6800 psia																																																																																													
BAT VDC	≥ 16.7																																																																																													
BAT AMP	3.0-4.0																																																																																													
RPM	18.0-20.0 K																																																																																													
CO2	0.2-4.0 mm																																																																																													
H2O TEMP	32-75 degF																																																																																													
H2O GP	14.0-16.0 psid																																																																																													
H2O WP	14.0-16.0 psid																																																																																													
DATA?	COMBO																																																																																													
BATT	32.0 AH (as directed by MCC-H)																																																																																													
GAUGE	4.2-4.4 psid (4.7 during/after depress) psid																																																																																													
<p style="text-align: center;"><b>DCM CONFIGURATION</b></p> <p><b>DCM CONFG INDEX</b></p>  <p style="text-align: center;">EVA COMM FREQUENCIES LOW=414.2 MHz      HIGH=417.1 MHz</p> <p style="text-align: right;">2 <span style="float: right;">08/01/05</span></p>	<p style="text-align: center;"><b>EMU MALFUNCTION INDEX</b></p> <table border="0"> <tr><td>14V SUP FAIL</td><td>27</td><td>O2 ACT FAULT</td><td>28</td></tr> <tr><td>5V REF FAIL</td><td>27</td><td>O2 IS OFF</td><td>28</td></tr> <tr><td>ABORT EVA</td><td>6</td><td>O2 LF (%)</td><td>28</td></tr> <tr><td>AIR FLOW CONT</td><td>24</td><td><b>O2 USE HIGH</b></td><td>15</td></tr> <tr><td>BATT AMPS HIGH</td><td>10</td><td>PWR LF (%)</td><td>28</td></tr> <tr><td>BATT V DECAY OR</td><td></td><td><b>RESRV H2O ON</b></td><td>18</td></tr> <tr><td>  BATT VDC LOW</td><td>11</td><td><b>RLF V FAIL</b></td><td>26</td></tr> <tr><td>BITE light</td><td>27</td><td>SCU PWR AVAIL</td><td>28</td></tr> <tr><td>BUS CK FAIL</td><td>27</td><td>SET H2O OFF</td><td>28</td></tr> <tr><td>COMM FAIL</td><td>23</td><td>SET O2 EVA</td><td>28</td></tr> <tr><td>CO2 HIGH</td><td>21</td><td>SET O2 PRESS</td><td>28</td></tr> <tr><td>CO2 SNSR BAD</td><td>22</td><td><b>SOP O2 ON</b></td><td>9</td></tr> <tr><td>DCS</td><td>4</td><td><b>SOP P LOW</b></td><td>14</td></tr> <tr><td>DRAM FAIL</td><td>27</td><td><b>SUBLM P</b></td><td>16</td></tr> <tr><td>EE CSUM FAIL</td><td>27</td><td><b>SUIT P EMERG</b></td><td>8</td></tr> <tr><td>FAN SW OFF</td><td>28</td><td><b>SUIT P HIGH</b></td><td>13</td></tr> <tr><td>FW ANOMALY</td><td>27</td><td><b>SUIT P LOW</b></td><td>12</td></tr> <tr><td>H2O GP LOW</td><td>17</td><td>SW/FAN FAIL</td><td>27</td></tr> <tr><td>H2O IS OFF</td><td>28</td><td><b>TERMINATE EVA</b></td><td>7</td></tr> <tr><td>H2O WP HIGH</td><td>19</td><td>TIME LF: XX</td><td>28</td></tr> <tr><td>LOSS OF COOLING</td><td>25</td><td>VENT SW FAIL</td><td>27</td></tr> <tr><td>MONITOR CO2</td><td>21</td><td><b>WAT DOG FAIL</b></td><td>27</td></tr> <tr><td>NO VENT FLOW</td><td>20</td><td></td><td></td></tr> </table> <p style="text-align: right;">NOTE: <b>BOLDFACE</b> ind detailed proc</p> <p style="text-align: right;">3 <span style="float: right;">05/11/06</span></p>	14V SUP FAIL	27	O2 ACT FAULT	28	5V REF FAIL	27	O2 IS OFF	28	ABORT EVA	6	O2 LF (%)	28	AIR FLOW CONT	24	<b>O2 USE HIGH</b>	15	BATT AMPS HIGH	10	PWR LF (%)	28	BATT V DECAY OR		<b>RESRV H2O ON</b>	18	BATT VDC LOW	11	<b>RLF V FAIL</b>	26	BITE light	27	SCU PWR AVAIL	28	BUS CK FAIL	27	SET H2O OFF	28	COMM FAIL	23	SET O2 EVA	28	CO2 HIGH	21	SET O2 PRESS	28	CO2 SNSR BAD	22	<b>SOP O2 ON</b>	9	DCS	4	<b>SOP P LOW</b>	14	DRAM FAIL	27	<b>SUBLM P</b>	16	EE CSUM FAIL	27	<b>SUIT P EMERG</b>	8	FAN SW OFF	28	<b>SUIT P HIGH</b>	13	FW ANOMALY	27	<b>SUIT P LOW</b>	12	H2O GP LOW	17	SW/FAN FAIL	27	H2O IS OFF	28	<b>TERMINATE EVA</b>	7	H2O WP HIGH	19	TIME LF: XX	28	LOSS OF COOLING	25	VENT SW FAIL	27	MONITOR CO2	21	<b>WAT DOG FAIL</b>	27	NO VENT FLOW	20			<p><b>DCS</b></p>
14V SUP FAIL	27	O2 ACT FAULT	28																																																																																											
5V REF FAIL	27	O2 IS OFF	28																																																																																											
ABORT EVA	6	O2 LF (%)	28																																																																																											
AIR FLOW CONT	24	<b>O2 USE HIGH</b>	15																																																																																											
BATT AMPS HIGH	10	PWR LF (%)	28																																																																																											
BATT V DECAY OR		<b>RESRV H2O ON</b>	18																																																																																											
BATT VDC LOW	11	<b>RLF V FAIL</b>	26																																																																																											
BITE light	27	SCU PWR AVAIL	28																																																																																											
BUS CK FAIL	27	SET H2O OFF	28																																																																																											
COMM FAIL	23	SET O2 EVA	28																																																																																											
CO2 HIGH	21	SET O2 PRESS	28																																																																																											
CO2 SNSR BAD	22	<b>SOP O2 ON</b>	9																																																																																											
DCS	4	<b>SOP P LOW</b>	14																																																																																											
DRAM FAIL	27	<b>SUBLM P</b>	16																																																																																											
EE CSUM FAIL	27	<b>SUIT P EMERG</b>	8																																																																																											
FAN SW OFF	28	<b>SUIT P HIGH</b>	13																																																																																											
FW ANOMALY	27	<b>SUIT P LOW</b>	12																																																																																											
H2O GP LOW	17	SW/FAN FAIL	27																																																																																											
H2O IS OFF	28	<b>TERMINATE EVA</b>	7																																																																																											
H2O WP HIGH	19	TIME LF: XX	28																																																																																											
LOSS OF COOLING	25	VENT SW FAIL	27																																																																																											
MONITOR CO2	21	<b>WAT DOG FAIL</b>	27																																																																																											
NO VENT FLOW	20																																																																																													

<p style="text-align: center;"><b>DECOMPRESSION SICKNESS (DCS)</b></p> <p style="text-align: center;"><b>Class 1</b></p> <p><b>Symptoms:</b> Mild pain (single/multiple sites) and/or single extremity numbness/tingling. Difficult to discern from suit pressure points. Symptoms do not interfere with performance</p> <p><b>Action:</b> Report in POST EVA PMC</p> <p><b>DCS</b></p> <p style="text-align: center;"><b>Class 2</b></p> <p><b>Symptoms:</b> Moderate Class 1 symptoms that interfere with performance or symptoms that resolve upon repress</p> <p><b>Action:</b> Perform worksite cleanup, minimize activity of affected crewmember. TERM EVA; REPRESS</p> <p style="text-align: center;">4</p> <p style="text-align: right;">01/18/05</p>	<p style="text-align: center;"><b>DECOMPRESSION SICKNESS (DCS) (CONT)</b></p> <p style="text-align: center;"><b>Class 3</b></p> <p><b>Symptoms:</b> Severe Class 1 symptoms or migratory, trunkal/multiple site numbness/tingling; unusual headache</p> <p><b>Action:</b> Assist affected crewmember to A/L, safe PLB, TERM EVA; REPRESS</p> <p style="text-align: center;"><b>Class 4</b></p> <p><b>Symptoms:</b> Serious symptoms – central neurological, cardiopulmonary</p> <p><b>Action:</b> ABORT EVA. Assisted return of affected crewmember to A/L, repress affected crewmember solo. Unaffected crewmember safe PLB, TERM EVA; REPRESS</p> <p style="text-align: center;">5</p> <p style="text-align: right;">01/18/05</p>
<p style="text-align: center;"><b>ABORT EVA</b></p> <div style="border: 2px solid black; padding: 5px; margin: 20px auto; width: 80%;"> <p><b>BOTH:</b> Ingress airlock.  Unhook from reel  Outer (EVA) hatch – close and lock  Go to <u>EMER REPRESS</u> decal  (airlock hatches)</p> </div> <p><b>ABORT EVA</b> <u>TERM EVA</u> <b>EVA</b></p> <p style="text-align: center;">6</p> <p style="text-align: right;">07/20/97</p>	<p style="text-align: center;"><b>TERMINATE EVA</b></p> <ol style="list-style-type: none"> <li>1. Ingress airlock</li> <li>2. Connect SCU</li> </ol> <div style="border: 2px solid black; padding: 5px; margin: 10px auto; width: 80%;"> <p style="text-align: center;"><u>WARNING</u>  If terminating due to BATT AMPS HIGH  (system short), do not perform step 3</p> </div> <p><b>AW18H</b> 3. PWR/BATT CHGR EMU 1(2) BUS SEL – MNA(MNB)</p> <p><b>IV</b> 4. √EMU O2 ISOL vlv – OP</p> <p><b>AW82B</b> 5. √EV-1(EV-2) O2 vlv – OP</p> <p style="text-align: center;"><u>NOTE</u></p> <p style="text-align: center;">If fan stops during power transfer:  Cycle FAN sw – OFF,ON</p> <p><b>DCM</b> 6. PWR – SCU (fwd)  7. WATER – OFF (fwd)  8. Verify SUIT P ≥ 3.3 and stable  If SUIT P &lt; 3.3:  9. Go to ABORT EVA, 6</p> <p>10. Monitor EMU status</p> <p>11. Coordinate ingress with EV1(2)</p> <p style="text-align: center;">7</p> <p style="text-align: right;"><b>SUIT P</b> <b>EMERG</b> <u>SOP</u> <b>ON</b></p> <p style="text-align: right;">04/28/06</p>



<p style="text-align: center;"><b>SUIT P LOW</b></p> <p><b>SUIT P LOW   SUIT P X.X</b></p> <p>If O2 USE HIGH msg present:    1. Go to ABORT EVA, 6 &gt;&gt;  If O2 USE HIGH msg not present:  2. Continue EVA, monitor SUIT P, SOP P, and gauge  If gauge &lt; 4.0 and SOP P decreasing:  3. Go to TERM EVA, 7</p> <p><b>SUIT P LO</b> <b>SUIT P HI</b></p> <p style="text-align: center;"><u>NOTE</u>  Msg triggered when SUIT P &lt; 4.05</p> <p style="text-align: right;">12                      05/11/06</p>	<p style="text-align: center;"><b>SUIT P HIGH</b></p> <p><b>SUIT P HIGH   O2 RATE XX.X   SOP RATE XXX</b></p> <p>If O2 RATE &gt; 7.0 or SOP RATE &gt; 8:    1. Go to TERM EVA, 7 &gt;&gt;  If O2 RATE &lt; 7.0 and SOP RATE ≤ 8:  2. Monitor SUIT P, SOP P, and gauge  3. Continue EVA</p> <p style="text-align: center;"><u>NOTE</u>  Msg triggered when SUIT P &gt; 4.55  Normal O2 RATE ≈1.7 psi/min</p> <p style="text-align: right;"><b>SOP LOW</b> <b>O2 USE</b></p> <p style="text-align: right;">13                      05/11/06</p>
<p style="text-align: center;"><b>SOP P LOW</b></p> <p><b>SOP P LOW   SOP P XXX0   SOP RATE XXX</b></p> <p>1. Go to TERM EVA, 7</p> <p style="text-align: center;"><u>NOTE</u>  Msg triggered when SOP P &lt; 4500, or SOP P &lt; init SOP P – 600 (SOP P initialized at EMU powerup)</p> <p><b>SOP LOW</b> <b>O2 USE</b></p> <p style="text-align: right;">14                      05/11/06</p>	<p style="text-align: center;"><b>O2 USE HIGH</b></p> <p><b>O2 USE HIGH   O2 RATE XX.X</b></p> <p>If SUIT P LOW msg present:    1. Go to ABORT EVA, 6 &gt;&gt;  If O2 P erratic or ~0:    2. Continue EVA    3. Recharge O2 periodically &gt;&gt;  If O2 RATE &gt; 7.0:    4. Go to TERM EVA, 7 &gt;&gt;  Otherwise:  5. Recharge O2 as reqd  6. Continue EVA</p> <p style="text-align: center;"><u>NOTE</u>  Msg triggered when:  O2 RATE &gt; 10.2 psi/min or  O2 P &lt; 150 and TIME EV &lt; 5 hr  Normal O2 RATE ≈1.7 psi/min</p> <p><b>SUBLM PRESS</b> <b>H2O GP</b></p> <p style="text-align: right;">15                      05/11/06</p>

**SUBLM PRESS**

**SUBLM P XX.X | SET H2O OFF**

1. √WATER – OFF (fwd)
  - If SUBLM P < 1.0 and stable:
    - When cooling desired, then:
      2. Temp control vlv – Max H
      3. WATER – ON (aft)
      4. Temp control vlv – as reqd
    - If cooling insufficient:
      - 5. Go to LOSS OF COOLING, 25, step 2 >>
    - If cooling sufficient:
      - 6. Continue EVA, monitor SUBLM P and cooling >>
  - If SUBLM P ≥ 1.0 and stable (sensor fail):
    - 7. Perform steps 2-4, continue EVA, monitor cooling

**NOTE**

Msg triggered when SUBLM P < 1.5 or > 5.3  
Normal SUBLM P = 2.0-4.2

**SUBLM PRESS**  
**H2O GP**

16 05/11/06

**H2O GP LOW**

**H2O GP LOW**

- If H2O WP < 13.5:
  - If cooling insufficient (H2O reg fail):
    1. Go to LOSS OF COOLING, 25, step 2
  - If cooling sufficient (H2O reg shifted):
    2. Monitor cooling
    3. Continue EVA >>
- If H2O WP ≥ 13.5 (sensor fail):
  4. Monitor H2O WP (**RESRV H2O ON**) msg may be inhibited
    - If H2O WP drops to < 12.0:
      5. Go to TERM EVA, 7

**NOTE**

Msg triggered when H2O GP < 13.5  
Normal H2O TEMP = 32-75 degF  
WP = 14.0-16.0

**RSRV H2O WP**

17 05/11/06

**RESRV H2O ON**

**RESRV H2O ON | TIME LF :XX**

H2O GP	H2O WP	ACTION
~15	~0	1. Monitor SUBLM P and H2O TEMP (WP xdcr fail)
> 17.0	~15	2. Monitor H2O WP and H2O TEMP (GP xdcr fail) If H2O WP drops to < 12.0: 3. Go to TERM EVA, 7
~15	< 12.0	4. Go to TERM EVA, 7 (reserve H2O on)

**NOTE**

Msg triggered when GP minus WP > 2.1 psi  
Normal SUBLM P = 2.0-4.2 psia  
H2O TEMP = 32-75 degF  
GP/WP = 14.0-16.0

**RSRV H2O WP**

18 05/11/06

**H2O WP HIGH**

**H2O WP HIGH | H2O WP XX.X**

- If H2O GP < 16.0 (H2O WP sensor failed):
  1. Monitor cooling (**RESRV H2O ON**) msg inhibited
  2. Continue EVA >>
- If O2 RATE > 7.0 (H2O reg failed open):
  3. Go to TERM EVA, 7 >>
- If O2 RATE ≤ 7.0 (H2O reg shifted):
  4. Monitor Suit P gauge and cooling
  5. Continue EVA

**NOTE**

Message triggered when H2O WP > 17.0  
Normal H2O WP and H2O GP: 14.0-16.0  
Normal H2O TEMP: 32 to 75 degF  
Normal O2 RATE ~ 1.7 psi/min  
Normal Suit P: 4.2-4.4 psi

**NO VENT CO2**

19 05/11/06



<p style="text-align: center;"><b>NO VENT FLOW</b></p> <div style="border: 1px solid black; padding: 2px; margin-bottom: 5px;"><b>NO VENT FLOW</b></div> <p>If fan is not running:</p> <ol style="list-style-type: none"><li>1. Cycle FAN sw – OFF,ON If fan restarts:<ol style="list-style-type: none"><li>2. Continue EVA &gt;&gt;</li></ol></li><li>If fan does not start:<ol style="list-style-type: none"><li>3. Helmet purge vlv – op</li><li>4. Go to TERM EVA, 7 &gt;&gt;</li></ol></li></ol> <p>If fan is running:</p> <p>If RPM &lt; 18.0 K:</p> <ol style="list-style-type: none"><li>5. Helmet purge vlv – op</li><li>6. Go to TERM EVA, 7 &gt;&gt;</li></ol> <p>If RPM ≥ 18.0 K:</p> <ol style="list-style-type: none"><li>7. Assess helmet CO2 level</li><li>8. Go to CO2 HIGH, 21, step 3</li></ol> <p style="text-align: center;"><u>NOTE</u> Msg triggered when flow &lt; 3.7 cfm Normal vent flow = 6-8 cfm</p> <p style="text-align: center;">20                                      05/11/06</p>	<p style="text-align: center;"><b>CO2 HIGH OR MONITOR CO2</b></p> <div style="border: 1px solid black; padding: 2px; margin-bottom: 5px;"><b>CO2 XX.X MM MONITOR CO2</b> – PPCO2 &gt; 8.0 MM</div> <ol style="list-style-type: none"><li>1. Minimize physical activity</li><li>2. Assess physical condition then go to step 3 below</li></ol> <div style="border: 1px solid black; padding: 2px; margin-bottom: 5px;"><b>CO2 HIGH OPEN PURGE V</b> – PPCO2 &gt; 12.4 MM</div> <ol style="list-style-type: none"><li>1. √DCM PURGE vlv – cl, √Helmet purge vlv – op</li></ol> <p>If symptoms noted prior to opening purge vlv:</p> <ol style="list-style-type: none"><li>2. Go to TERM EVA, 7 &gt;&gt;</li></ol> <p>If no symptoms noted (or inconclusive):</p> <ol style="list-style-type: none"><li>3. Close/open helmet purge vlv as reqd to assess physical condition for high CO2</li></ol> <p>If symptoms noted:</p> <ol style="list-style-type: none"><li>4. Helmet purge vlv – op</li><li>5. Go to TERM EVA, 7 &gt;&gt;</li></ol> <p>If no symptoms noted:</p> <ol style="list-style-type: none"><li>6. Helmet purge vlv – cl, locked</li><li>7. Monitor physical condition and PPCO2</li><li>8. Continue EVA</li></ol> <p style="text-align: center;"><u>NOTE</u> Normal PPCO2 = 0.2-4.0 MM If Suit P sensor failed: MONITOR CO2: 3.0 MM, CO2 HIGH: 8.0 MM</p> <p style="text-align: center;">21                                      05/11/06</p> <p style="text-align: right;"><b>CO2 SNSR COMM FAIL</b></p>																	
<p style="text-align: center;"><b>CO2 SNSR BAD</b></p> <div style="border: 1px solid black; padding: 2px; margin-bottom: 5px;"><b>CO2 SNSR BAD</b></div> <ol style="list-style-type: none"><li>1. Periodically monitor physical condition (CO2 sensor failed)</li></ol> <p>If CO2 symptoms noted:</p> <ol style="list-style-type: none"><li>2. Helmet purge vlv – op</li><li>3. Go to TERM EVA, 7 &gt;&gt;</li><li>4. Continue EVA</li></ol> <p style="text-align: center;"><u>NOTE</u> Message triggered when PPCO2 increases from nominal value to ≥ 40 MM in &lt; 2 min. Normal PPCO2: 0.2-4.0 MM</p> <p style="text-align: center;">22                                      05/11/06</p> <p style="text-align: left;"><b>CO2 SNSR COMM FAIL</b></p>	<p style="text-align: center;"><b>COMM FAILURE</b></p> <table border="0"><tr><td style="vertical-align: top;"><b>ALL</b></td><td>1. √Proper config, EMU and orbiter (Mode, Vol, Freq) Perform following sequence until comm restored:</td><td rowspan="2" style="text-align: right; vertical-align: middle;"><b>AIR FLOW LOSS COOL</b></td></tr><tr><td><b>BOTH</b></td><td>If EV cm hears intermittent sidetones/comm or no sidetones:<ol style="list-style-type: none"><li>2. Clear structure to recover comm (signal blockage) If unresolved:<ol style="list-style-type: none"><li>3. Aff cm select ALT(PRI) (notify MCC)</li></ol></li></ol></td></tr><tr><td><b>IV</b></td><td>If IV no comm with EV1 and EV2:</td><td></td></tr><tr><td><b>O6</b></td><td>4. IV select STRING 2(1)</td><td></td></tr><tr><td><b>ALL</b></td><td>If unresolved:<ol style="list-style-type: none"><li>5. Perform coordinated freq change</li></ol></td><td></td></tr><tr><td></td><td>If unable to restore minimum of relay comm:<ol style="list-style-type: none"><li>6. Go to TERM EVA, 7</li></ol></td><td></td></tr></table> <p style="text-align: center;">23                                      05/11/06</p>	<b>ALL</b>	1. √Proper config, EMU and orbiter (Mode, Vol, Freq) Perform following sequence until comm restored:	<b>AIR FLOW LOSS COOL</b>	<b>BOTH</b>	If EV cm hears intermittent sidetones/comm or no sidetones: <ol style="list-style-type: none"><li>2. Clear structure to recover comm (signal blockage) If unresolved:<ol style="list-style-type: none"><li>3. Aff cm select ALT(PRI) (notify MCC)</li></ol></li></ol>	<b>IV</b>	If IV no comm with EV1 and EV2:		<b>O6</b>	4. IV select STRING 2(1)		<b>ALL</b>	If unresolved: <ol style="list-style-type: none"><li>5. Perform coordinated freq change</li></ol>			If unable to restore minimum of relay comm: <ol style="list-style-type: none"><li>6. Go to TERM EVA, 7</li></ol>	
<b>ALL</b>	1. √Proper config, EMU and orbiter (Mode, Vol, Freq) Perform following sequence until comm restored:	<b>AIR FLOW LOSS COOL</b>																
<b>BOTH</b>	If EV cm hears intermittent sidetones/comm or no sidetones: <ol style="list-style-type: none"><li>2. Clear structure to recover comm (signal blockage) If unresolved:<ol style="list-style-type: none"><li>3. Aff cm select ALT(PRI) (notify MCC)</li></ol></li></ol>																	
<b>IV</b>	If IV no comm with EV1 and EV2:																	
<b>O6</b>	4. IV select STRING 2(1)																	
<b>ALL</b>	If unresolved: <ol style="list-style-type: none"><li>5. Perform coordinated freq change</li></ol>																	
	If unable to restore minimum of relay comm: <ol style="list-style-type: none"><li>6. Go to TERM EVA, 7</li></ol>																	

<p><b>AIR FLOW</b> <b>LOSS COOL</b></p>	<p align="center"><b>AIR FLOW CONTAMINATION</b></p> <p>If flow exiting helmet vent contaminated by caustic water or LiOH dust:</p> <ol style="list-style-type: none"> <li>1. Helmet purge vlv – op</li> <li>2. FAN – OFF</li> <li>3. WATER – OFF</li> </ol> <p>If contamination still present:</p> <ol style="list-style-type: none"> <li>4. Go to ABORT EVA, 6 &gt;&gt;</li> </ol> <p>Otherwise:</p> <ol style="list-style-type: none"> <li>5. Go to TERM EVA, 7 &gt;&gt;</li> </ol> <p>If excessive water in vent loop or helmet:</p> <ol style="list-style-type: none"> <li>6. Contact MCC</li> </ol> <p align="center"><u>NOTE</u> EMU water tanks hold ≈1 gal H2O</p> <p align="center">24 <span style="float:right">05/11/06</span></p>	<p align="center"><b>LOSS OF COOLING</b></p> <ol style="list-style-type: none"> <li>1. Temp Control vlv – cycle 3 to Max C; leave in Max C</li> </ol> <p>If cooling restored, continue EVA &gt;&gt;</p> <ol style="list-style-type: none"> <li>2. Begin translation to airlock for TERM EVA</li> </ol> <p>If SCU cannot be connected prior to overheating:</p> <ol style="list-style-type: none"> <li>3. Helmet purge vlv – op, lock</li> <li>4. If vent flow excessively hot: FAN – OFF</li> </ol> <p><b>DCM</b> If helmet purge flow insufficient for cooling:</p> <ol style="list-style-type: none"> <li>5. Helmet purge vlv – cl, lock</li> <li>6. DCM purge vlv – op</li> <li>7. Connect SCU to DCM</li> <li>8. √FAN – ON</li> </ol> <p><b>IV</b> √EMU O2 ISOL vlv – OP</p> <p><b>AW82B</b> 9. √EV-1(2) O2 vlv – OP</p> <p>If cooling sufficient:</p> <ol style="list-style-type: none"> <li>10. √Helmet purge vlv – cl, locked</li> <li>11. √DCM purge vlv – cl, locked</li> </ol> <p>If cooling insufficient:</p> <ol style="list-style-type: none"> <li>12. Perform steps 3-6</li> <li>13. Go to TERM EVA, 7</li> </ol> <p align="right">25 <span style="float:left">05/11/06</span></p> <p align="right"><b>RLF VLV</b> <b>MISC 1</b></p>																					
<p><b>RLF VLV</b> <b>MISC 1</b></p>	<p align="center"><b>RLF V FAIL</b></p> <table border="1"> <tr> <td>RLF V FAIL</td> <td>STOP DEPRESS</td> <td>SUIT P X.X</td> </tr> </table> <p>AW82B 1. AIRLK DEPRESS vlv – CL</p> <ol style="list-style-type: none"> <li>2. √Suit P gauge</li> <li>3. Contact MCC</li> </ol> <p align="center"><u>NOTE</u> Message triggered when SUIT P &gt; 5.7</p> <p align="center">26 <span style="float:right">05/11/06</span></p>	RLF V FAIL	STOP DEPRESS	SUIT P X.X	<p align="center"><b>MISC MSGS 1</b></p> <table border="1"> <tr> <td>FW ANOMALY</td> <td>– Feedwater discretes in disagreement</td> </tr> <tr> <td>SW/FAN FAIL</td> <td>– Verify RPMs nominal</td> </tr> <tr> <td>VENT SW FAIL</td> <td>– Vent flow sensor unreliable</td> </tr> </table> <p><u>Built-In Tests</u> ☒ (BITE light illuminated) – may be accompanied by one of following messages: <u>For all cases, perform following sequence:</u></p> <table border="1"> <tr> <td>14V SUP FAIL</td> <td>1. √STATUS, IV record</td> </tr> <tr> <td>5V REF FAIL</td> <td>If status list nominal:</td> </tr> <tr> <td>BUS CK FAIL</td> <td>2. Continue EVA, inform MCC &gt;&gt;</td> </tr> <tr> <td>DRAM FAIL</td> <td>If status list unreadable or erroneous</td> </tr> <tr> <td>EE CSUM FAIL</td> <td>3. Go to TERM EVA, 7</td> </tr> <tr> <td>WAT DOG FAIL</td> <td>4. Inform MCC</td> </tr> </table> <p align="right">27 <span style="float:left">05/11/06</span></p> <p align="right"><b>MISC 2</b> <b>A/L DISC</b></p>	FW ANOMALY	– Feedwater discretes in disagreement	SW/FAN FAIL	– Verify RPMs nominal	VENT SW FAIL	– Vent flow sensor unreliable	14V SUP FAIL	1. √STATUS, IV record	5V REF FAIL	If status list nominal:	BUS CK FAIL	2. Continue EVA, inform MCC >>	DRAM FAIL	If status list unreadable or erroneous	EE CSUM FAIL	3. Go to TERM EVA, 7	WAT DOG FAIL	4. Inform MCC
RLF V FAIL	STOP DEPRESS	SUIT P X.X																					
FW ANOMALY	– Feedwater discretes in disagreement																						
SW/FAN FAIL	– Verify RPMs nominal																						
VENT SW FAIL	– Vent flow sensor unreliable																						
14V SUP FAIL	1. √STATUS, IV record																						
5V REF FAIL	If status list nominal:																						
BUS CK FAIL	2. Continue EVA, inform MCC >>																						
DRAM FAIL	If status list unreadable or erroneous																						
EE CSUM FAIL	3. Go to TERM EVA, 7																						
WAT DOG FAIL	4. Inform MCC																						

**MISC MSGS (CONT) / TIME LF**

**MISC 2  
A/L  
DISC**

FAN SW OFF
H2O IS OFF
O2 ACT FAULT
O2 IS OFF
SET H2O OFF
SET O2 EVA
SET O2 PRESS
SCU PWR AVAL

Verify proper config

Consumables

XX% O2 LF	TIME LF 'MM
XX% PWR LF	TIME LF 'MM

Triggered with 30 min of calculated time remaining for limiting consumable

- Contact MCC to confirm calculation

- \* If no comm with MCC: \*
- \* Go to TERM EVA, 7 \*

28

05/11/06

**AIRLOCK LATCH DISCONNECT**

TOOL BOX/A/L – ADJ WRENCH, RATCHET WITH 7/16 SOCKET  
TOOL BOX – EVA TRASH BAG, ADJ TETHERS

- Remove bolt A, stow in trash bag
  - Rotate actuator handle
- If no rotation – jammed actuator:
- Force latches open
  - Seal hatch w/repress and secure for Idg (IV)
- If free rotation – jammed latch:
- Locate and remove jam
  - Reconnect actuator

**HINGE DISCONNECT**

TOOL BOX – ADJ TETHERS, VELCRO/TAPE

- Remove hinge PIP pins, as reqd
- Restrain hinge arm(s) and PIP pins clear of opening, ingress airlock, posn hatch for closing
- Close, lock hatch

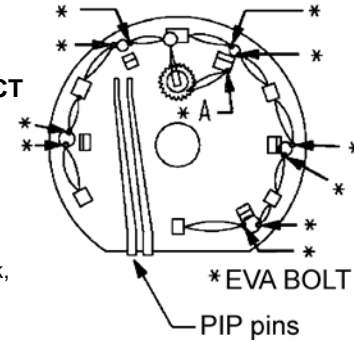

29

05/11/06

**AIRLOCK INGRESS**

- ✓ TOOL BOX – closed, latched
- EV2**
- Ingress airlock
- Attach waist tether to A/L internal D-ring; lock hook
- EV1**
- Attach EV2's safety tether, retracting end to waist tether; lock hooks
  - Disconnect EV1 safety tether, retracting end – attach to self
- Ingress airlock
- BOTH**
- Unstow SCU, remove DCM cover, connect SCU to DCM (not reqd for tunnel adapter)
  - DCM WATER – OFF (fwd)
  - Thermal cover – close

**CAUTION**  
Do not close hatch until EMU WATER is OFF for 2 min

- EVA hatch handle – pre close posn
- ✓ EVA hatch seal clear, outer (EVA) hatch – close, lock
- Go to PRE REPRESS (DEPRESS/REPRESS Cue Card)

30

11/03/06

**RADIATOR ACTUATOR DISCONNECT**

IFM – 1/4-in ALLEN HEAD DRIVER  
TOOL BOX – RADIATOR DISCONNECT/ 3/8 DRIVE RATCHET

- IV** ✓Pwr off
- Actuator disc sequence – aft to fwd
- Yellow shear pins (4) – retract to stop (6 revs ccw)
- When all actuators are disengaged:
- Manually close radiator panels and hold
- IV** ✓Pwr on
- IV** Latches – close

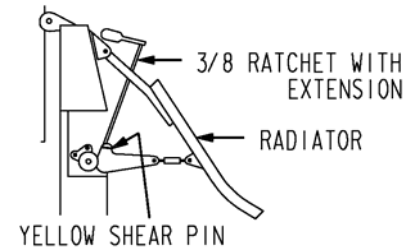

NOT IN EV CUFF

31

03/20/06

### PLBD DRIVE CUT

TOOL BOX – TUBE CUTTER, VELCRO/TAPE

IV √Pwr off

Cut #1, stow antenna if stbd side, perform WINCH OPS, 35, steps 1,2, then cut #6 thru #2 and perform WINCH OPS, 36, steps 3-7

BANDS VISIBLE	CORRECTIVE ACTION
1-6	Cut upper rod in middle and restrain (27)
7-10	Cut lower rod between 2nd and 3rd bands from top and restrain (27)

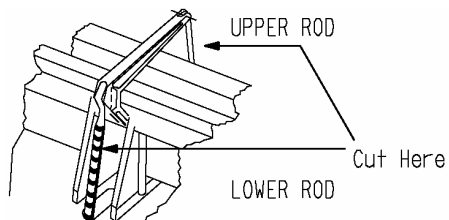

NOT IN EV CUFF

32

05/11/06

### DOOR DRIVE RESTRAINT

TOOL BOX – TAPE

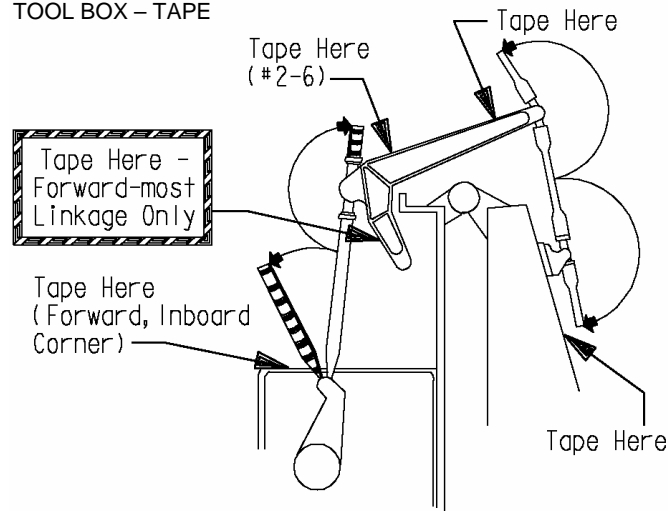

NOT IN EV CUFF

33

03/20/06

### DOOR DRIVE DISCONNECT

TOOL BOX – PDU DISC TOOL, TRASH BAG

IV √Pwr off

1. Perform WINCH OPS, 35, steps 1,2
2. Remove fabric cover(s)
3. Insert Disc Tool in Door Drive PDU  
Xo – 798, port OR stbd
4. Rotate tool cw to stop (60 deg) and leave tool in PDU
5. Rotate torque shaft at least 3 turns (see below)
6. Perform WINCH OPS, 36, steps 3-7
7. If reqd for other door, rotate tool ccw 60 deg and remove from PDU



NOT IN EV CUFF

34

05/11/06

### WINCH OPERATIONS

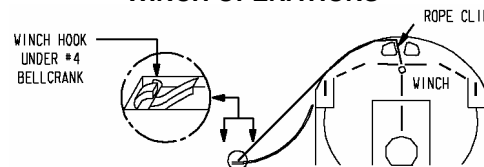

IV Radiators – stow and latch

1. Winch  
CONTROL – REEL OUT  
Handle ratchet – blue (center)  
Attach rope to wrist tether  
Rope: Fwd – in clip and over rollers  
Aft – rope guide, under handrail, and over rollers  
Winch hook – under #4 latch bellcrank  
CONTROL – IN  
Handle ratchet – green (cw)
2. Ratchet in rope slack only

Cont next pg

NOT IN EV CUFF

35

03/20/06

### WINCH OPERATIONS (CONT)

- IV** √Pwr off  
 3. PLBD(s) – close with winch  
 If aft not READY TO LATCH, repeat steps 1 and 3 at aft winch
- IV** √Pwr on
- IV** Latches – close
4. Winch hook – remove from PLBD
  5. Rope – reel in excess
  6. Handle – stow
  7. Repeat steps 5-7 for aft winch, if reqd

NOT IN EV CUFF

36

03/20/06

### 3-PT TOOL INSTALLATION

TOOL BOX – 3-PT TOOLS, ADJUSTABLE TETHERS

- IV** √Pwr off
1. Position installation handles as reqd
  2. Tools – install in sequence per IV table
  3. Ratchet select lever – green
  4. Handle – ratchet to hard stop – stow handle or restrain with Adj tether

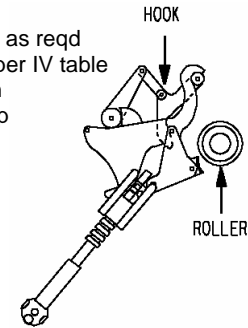

### TOOL RESET

1. Ratchet – red
2. Handle – ratchet to stop
3. Tool – compress to latch handles

NOT IN EV CUFF

37

03/20/06

### CL LATCH TOOL

TOOL BOX – CL LATCH TOOLS

- IV** √Pwr off
1. Tools – install per IV table
  2. Trigger – safety off – depress
  3. Ratchet select lever – green
  4. Handle – ratchet to hard stop – stow

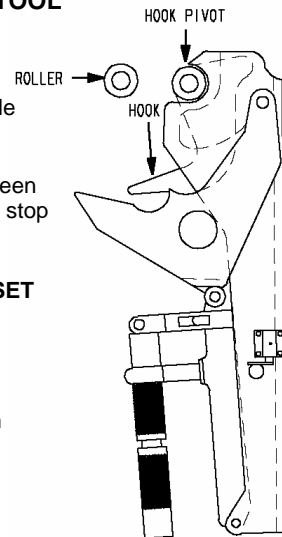

### TOOL RESET

1. Ratchet – red
2. Handle – ratchet to stop – stow
3. Tool – compress to latch

STBD →  
03/20/06

NOT IN EV CUFF

38

### RMS JOINT ALIGN

TOOL BOX – ADJ TETHERS, SNATCH BLOCKS (2), RMS ROPE REEL

1. Attach RMS rope around end effector under handrail. Translate to avoid wrapping rope around RMS
  2. Attach snatch block(s) to handrail(s) and route rope as reqd
- IV**
3. Reposition RMS as required for cradling
  4. Pull RMS down into MPMs
  5. Perform final positioning by hand to allow MRLs to latch

### RMS SHOULDER BRACE RELEASE

TOOL BOX – RMS SHOULDER BRACE RELEASE TOOL

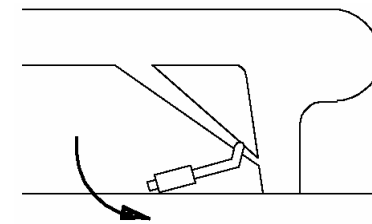

1. Fold aside rub strip and thermal blankets
2. Insert tool and move handle down
3. Remove tool and reconfigure blankets

NOT IN EV CUFF

39

03/20/06

### MPM STOW/DEPLOY

TOOL BOX – MPM WRENCH

1. Rotate torque shaft (8 revs) until MPMs are stowed/deployed, X<sub>0</sub>=693

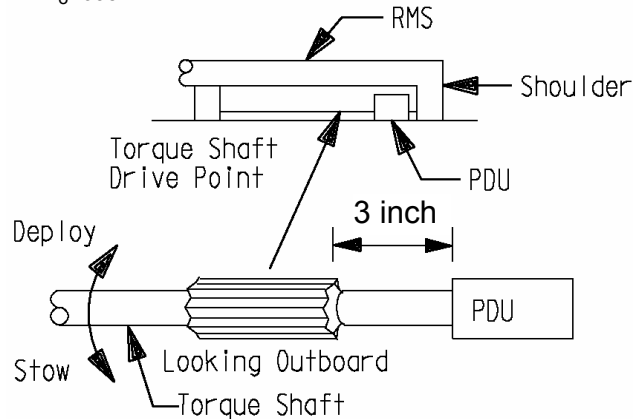

NOT IN EV CUFF

40

03/20/06

### RMS TIEDOWN

TOOL BOX – PRDs (2), EVA TRASH BAG

IFM – 9/64-in ALLEN WRENCH (AW)

ELBOW – PRD aft of MPM, peel blanket (fwd of MPM) toward EE; feed hook under cable harness (if reqd, remove cable harness clamp bolt with AW, bend clamp out of way), adjust strap as far fwd as possible

WRIST – PRD aft of MPM, strap rests just fwd of pitch joint opening

END EFFECTOR – PRD fwd of MPM, peel blankets aft and fwd, strap rests aft-most on yaw joint (at roll/yaw I/F), adjust strap under bolt studs

1. Figure eight the strap
2. Pull minimum 6-in slack in strap
3. Ratchet PRD snug, (14 full strokes reqd)
4. ✓Strap in correct arm location, ratchet tight
5. Reattach blankets

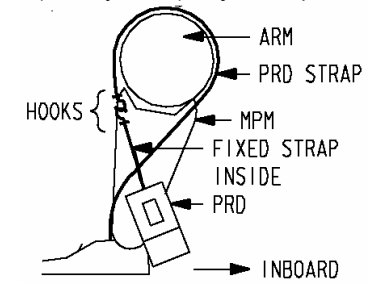

NOT IN EV CUFF

41

03/20/06

### RMS FLIGHT RELEASABLE GRAPPLE FIXTURE RELEASE

AIRLOCK – JETTISON STOWAGE BAG

TOOL BOX – 1/2-in BOX RATCHET, VELCRO/TAPE

- EV**
1. Rotate 10 o'clock posn release rod ccw to hard stop (~36 strokes of 90 deg)
  2. Rotate 4 o'clock posn release rod cw to hard stop (~36 strokes of 90 deg – shaft will release from grapple fixture)
  3. Clear worksite for RMS powerdown
  4. Tape end of shaft to restrain slug within shaft
  5. Cover end effector with jettison stowage bag to restrain grapple shaft

NOT IN EV CUFF

42

12/19/07

### PRLA OPEN/CLOSE

AIRLOCK – RATCHET WITH 7/16 SOCKET

**IV** ✓PRLA PWR OFF

- EV**
1. Rotate ratchet in release direction (as marked above EVA drive) to shear pin
  2. View yellow indicator as applicable
  3. Continue to rotate drive 4-1/2 revs to disc gear train from drive shaft

To open latch:

4. Continue rotation in release direction (as marked above EVA drive) until latch open against stop

To close latch:

5. Rotate EVA drive in opposite direction of release (as marked above EVA drive) until latch closed against hardstop and over center

**IV** ✓PRLA to LAT

Cont next pg

NOT IN EV CUFF

43

03/20/06

**PRLA OPEN/CLOSE (CONT)**

- EV**
6. Apply PRLA locking feature if applicable  
To lock:
    7. Rotate each bolt (two) cw 1/2 turn
- For subsequent PRLA ops, release locking feature before operating EVA drive (two bolts ccw 1/2 turn); relock after operation

NOT IN EV CUFF                      44                      03/20/06

**KU ANTENNA STOW**

1. Secure tether reel clear of antenna dish with wrist tether

**CAUTION**  
Antenna dish is very fragile. Avoid contact with gold thermal blankets and black painted surfaces

2. Align  $\alpha$  (dish roll) and  $\beta$  (dish pitch) gimbals for pin engagement
3. Give IV GO to drive pins in short pulses

**NOTE**  
Top lockarm (by wide beam horn and gold foil) drives fully before bottom lockarm (by silver gyro box)

NOT IN EV CUFF                      45                      03/20/06

**KU ANTENNA STOW (CONT)**

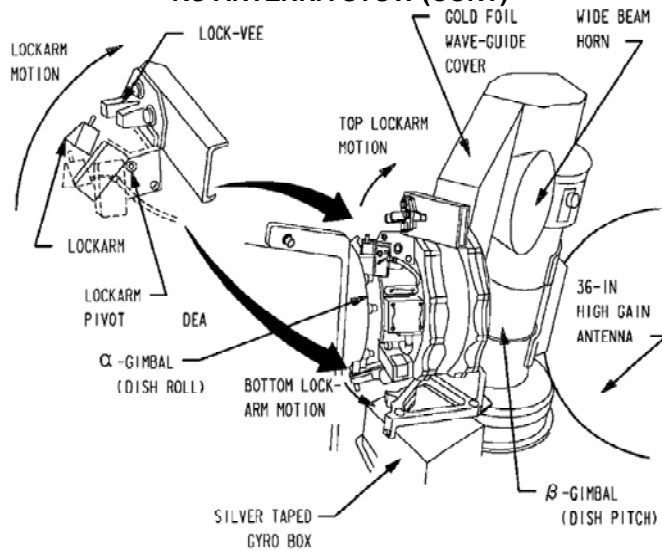

NOT IN EV CUFF                      46                      03/20/06

**AIRLOCK EGRESS**

**DAISY CHAIN:** EV2 waist tether to A/L internal D-ring  
EV2 safety tether (retracting end) to EV1 waist tether

- EV1**
1. Thermal cover – open
  2. Egress airlock
  3. Attach safety tether, retracting end to ODS dogbone handrail (or orbiter handrail tether point); lock hook,  $\checkmark$  reel unlocked
  4. Attach EV2's safety tether, retracting end to separate ODS dogbone handrail; lock hook,  $\checkmark$  reel unlocked
- BOTH**
5. Waist tethers – attach to self, stow extra waist tether (if reqd) in A/L clear of hatch
- EV2**
6. Egress airlock
  7. Thermal cover – close

NOT IN EV CUFF                      47                      11/03/06

This Page Intentionally Blank



FLIGHT SPECIFIC REFERENCE

----- FS REF -----

----- FS REF -----

This Page Intentionally Blank

UNSCHEDULED/CONTINGENCY EVA TASKS

This Page Intentionally Blank

EVA REFERENCE

This Page Intentionally Blank

Replace this page with page(s) from Flight Supplement

Replace this page with page(s) from Flight Supplement



EVA EMERGENCY

-----EVA EMERGENCY-----

-----EVA EMERGENCY-----

This Page Intentionally Blank

EMERGENCY PROCEDURES

EMERGENCY AIRLOCK REPRESS ..... 19-3  
    EMERGENCY AIRLOCK REPRESS ..... 19-4  
    POST EMERGENCY AIRLOCK REPRESS ..... 19-4  
SAFER RESCUE ..... 19-5  
    SAFER RESCUE ..... 19-6  
DAP/EVA RESCUE/RETRIEVE ..... 19-7  
    EVA ORBITER CONFIG ..... 19-7  
    RESCUE/RETRIEVE ..... 19-9  
19.1 DCS TREATMENT ..... 19-10  
CONTINGENCY SHUTTLE AIRLOCK INGRESS FROM ISS..... 19-13 |

EMER PROCS

This Page Intentionally Blank

EMERGENCY AIRLOCK REPRESS

**EMERGENCY AIRLOCK REPRESS**

NOTE: Ignore CWS functions

**Outer (EVA) hatch – close and lock**

**Inner hatch Equal vlv (two) – EMER**

AW82B: √AIRLK DEPRESS vlv – CL

DCM: WATER – OFF (fwd)

Open inner hatch

Go to POST EMERGENCY AIRLOCK REPRESS

**POST EMERGENCY AIRLOCK REPRESS**

WARNING

This procedure should not be performed following a Cuff 4 DCS incident

For affected crewmember:

- |       |   |
|-------|---|
| DCM   | 1. PURGE vlv – op (up)  |
|       | 2. O2 ACT – OFF   |
|       | 3. √STATUS: <span style="border: 1px solid black; padding: 2px;">SUIT P</span> < 0.4 (compare with gauge) |
|       | 4. Disconnect gloves  |
|       | 5. Disconnect helmet  |
|       | 6. Connect SCU to DCM   |
| AW18H | 7. PWR/BATT CHGR EMU 1(2) BUS SEL – MNA(MNB)  |
| DCM   | 8. PWR – SCU  |

For unaffected crewmember:

- |       |   |
|-------|---|
| DCM   | 9. O2 ACT – IV                                |
|       | 10. Connect SCU to DCM                        |
| AW18H | 11. PWR/BATT CHGR EMU 1(2) BUS SEL – MNA(MNB) |
| DCM   | 12. PWR – SCU                                 |

If single crewmember aborting EVA:

- |  |   |
|--|---|
|  | 13. Outer (EVA) hatch Equal vlv caps (two) – remove, stow |
|  | 14. √MCC  |

SAFER RESCUE

SAFER  
RESCUE

## SAFER RESCUE

1. Deploy SAFER HCM
2. PWR – ON
3. Wait for AAH, line up with separation point  
Fly to vehicle  
Monitor GN2% and PWR%

- \* If no gas flow: \*
- \* √MAN ISOL vlv – OP (dn) \*

- IV/other EV
4. Provide GCA (as reqd)  
Provide range and range rate using Laser Range Finder, as reqd  
Configure WVS and vehicle cameras to assist  
Turn on external vehicle lights, as reqd
  5. Tether to nearest structure, √connection
  6. Tether to available safety tether or other EV crewmember, √connection
  7. PWR – OFF
  8. MAN ISOL vlv – CL (up)
  9. √MCC

SAFER  
RESCUE



# EVA ORBITER CONFIG

## 1. GENERIC ORBITER CONFIGURATION

- A6U SENSE – as reqd  
 FLT CNTLR PWR – OFF  
 DAP TRANS: PULSE/PULSE/PULSE
- O14, O15, O16 cb MNA,C DDU AFT (two) – cl  
 Pri RJD LOGIC,DRIVER (sixteen) – ON
- GNC 20 DAP CONFIG
- CRT  $\sqrt{\text{PRI TRAN PLS – ITEM 17 +0.10}}$   
 $\sqrt{\text{ITEM 37 +0.05}}$
- A1U  $\sqrt{\text{KU CNTL – CMD}}$   
 PWR – STBY

Unstow, review EVA RESCUE procedure

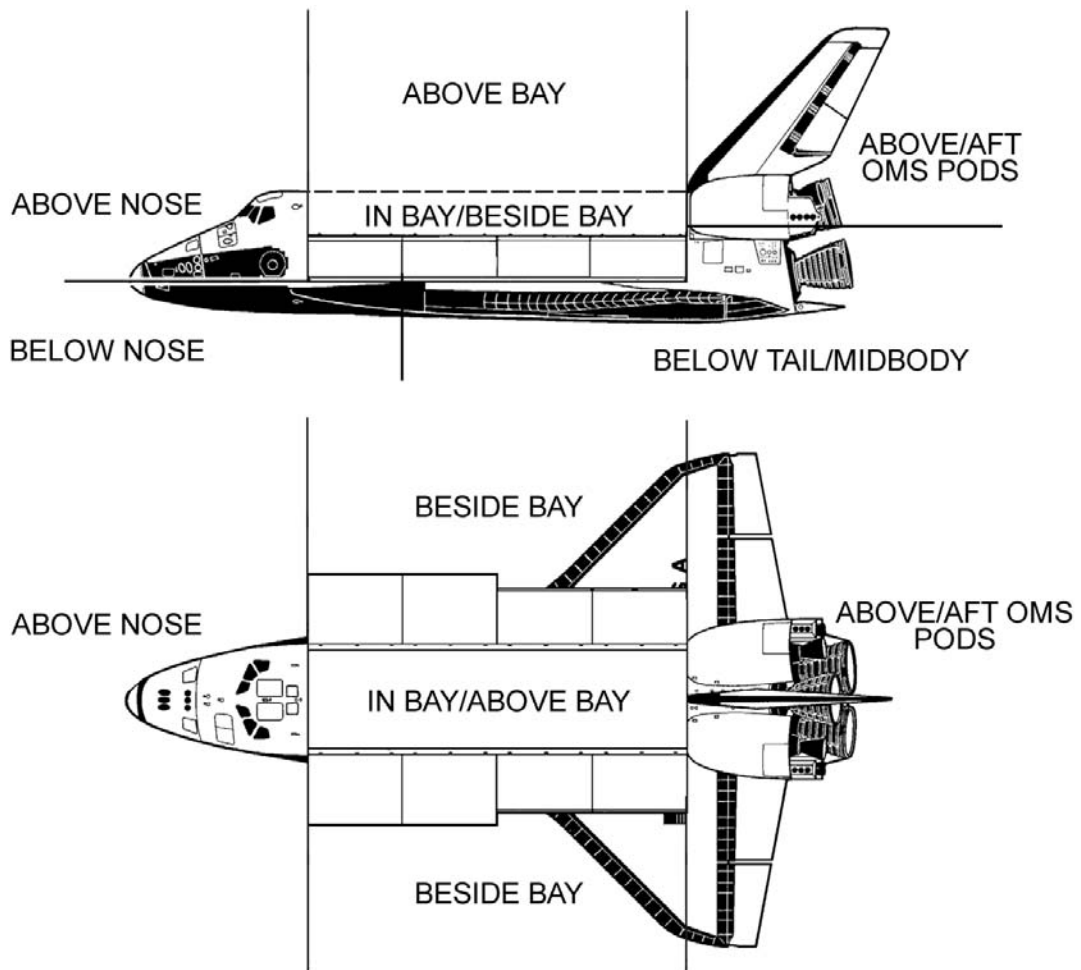

DAP/  
EVA RESCUE

2. REGION-SPECIFIC ORBITER CONFIGURATION

Using region charts, determine region(s) in which EVA crewmembers will be located

Working in order top of table to bottom using the most restrictive region, configure orbiter systems per following table, performing any Initial Configuration Actions which contain a '√'

Items which do not have a '√' may be configured as desired to meet mission-specific requirements

**WARNING**  
 Deviating from orbiter systems configuration called out in following table may put EVA crewmembers at risk of being plumed by RCS jets

NOTE

The following table should be used for initial configuration. It should not be used during the EVA (e.g., for EVA RESCUE).

If VERNs not available, use ALT instead. All other configuration actions remain unchanged

		In Bay	Above Bay	Above Nose	Above/Aft OMS Pods	Below Tail/Mirbody	Below Nose	Beside Bay
<b>INITIAL CONFIGURATION ACTIONS</b>								
D	VERN	√	√	√				√
A	ALT				√	√	√	
P	LOW Z		√					
	No LOW Z			√		√	√	
SPEC 20	P/Y/JET OPTION (PRI & ALT, DAP A & B) – ALL				√	√		
	P/Y/JET OPTION (PRI & ALT, DAP A & B) – TAIL			√			√	
SPEC 23	OVRD L/R MANFs 1,2,4 (six) – CL				√			
	L3L,R3R (two) – DES				√			
	OVRD L/R MANFs 2,3,4 (six) – CL					√		
	L1L,R1R (two) – DES					√		
O14,	RJDA L1/R1 (L2/R2, L4/R4) DRIVER (three) – OFF				√			
O15,	RJDA L2/R2 (L3/R3, L4/R4) DRIVER (three) – OFF					√		
O16	RJD MANF L5/F5/R5 DRIVER – OFF				√	√	√	
	RJDF F1(F2,F3,F4) MANF DRIVER – OFF (four)			√			√	
MISC	FLT CNTLR PWR (three) – OFF				√	√		√

3. POST-EVA RECONFIGURATION

Return orbiter to desired/required systems configs

DAP/  
EVA RESCUE

## EVA RESCUE/RETRIEVE

### NOTE

Assumes that EVA ORBITER CONFIG procedure has already been performed

1. CONFIGURATION
- A6U DAP: FREE(INRTL)
- √SENSE SWITCH as desired
- O14:F, √Pri RJD LOGIC,DRIVER (sixteen) – ON  
O15:F,  
O16:F
- O16:F √RJD MANF L5/F5/R5 DRIVER – ON
- GNC 23 RCS
- A1U OVRD L/R MANF – OP (if OVRD CLOSED earlier)  
KU CNTL – PNL

2. OPERATIONS

### NOTE

When EVA crewmember clear of RCS jets,  
FLT CNTLR PWR ON and DAP INRTL

If TRANSLATION:

| DAP: LO Z, as reqd (DAP A has larger TRANS PULSE size)

If ROTATION:

DAP: VERN(PRI), as reqd

### NOTE

Translate, then rotate, as reqd to center crewmember over bay.

Null translational rates, then establish closing(opening) rate as reqd to crewmember in bay.

Use RMS and/or other EVA crewmember to assist if possible

# 19.1 DCS TREATMENT

DCS Signs and Symptoms Associated with Each Cuff Class Defined in Cuff C/L

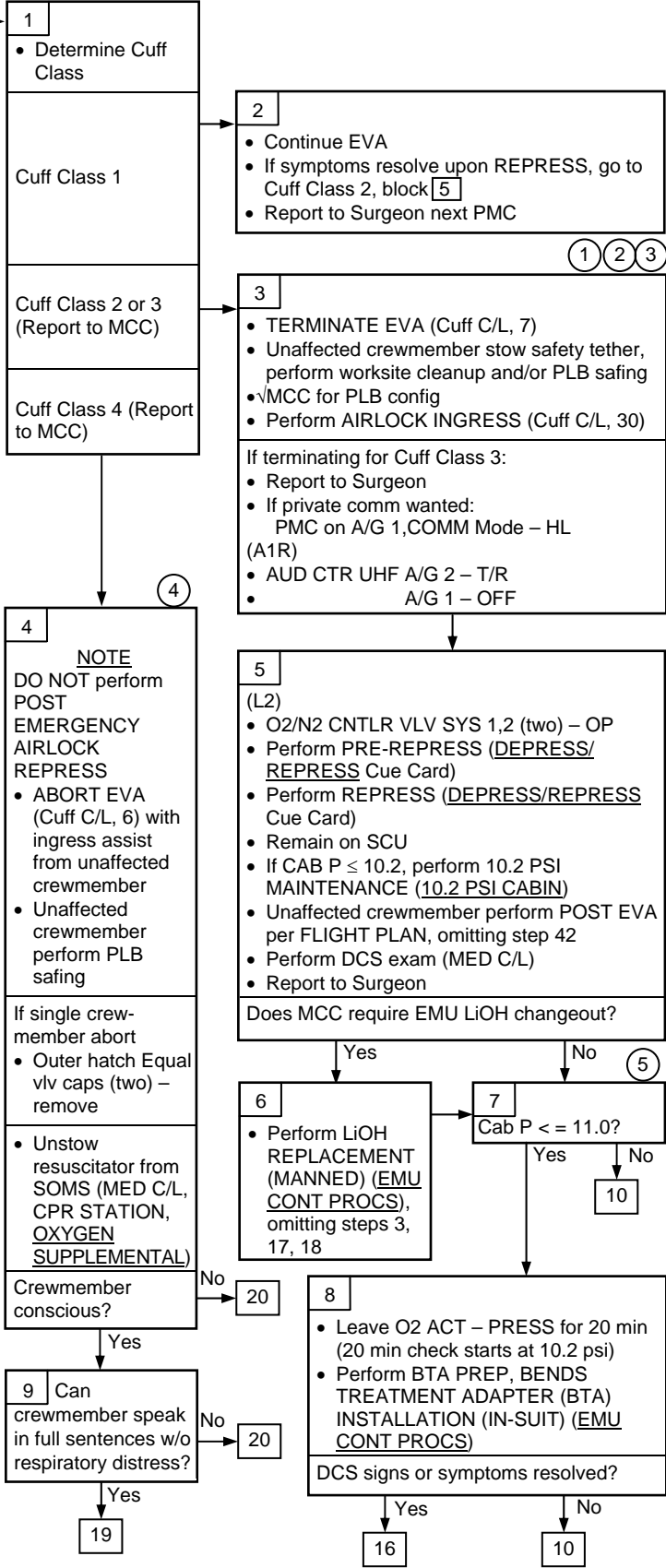

① EVA terminated to prevent progression to Cuff Class 4. If Cuff 2, affected crewmember will assist other EV with minor worksite cleanup, if possible, to expedite cleanup and then terminate EVA

② If estimated time reqd for DCS treatment exceeds LiOH consumables, a changeout should be performed. If 10 or 12 reqd, minimum treatment is ~3 hr

③ For Cuff 2 or 3, private comm not required to allow for expedited treatment. For Cuff Class 3 only, affected crewmember waiting in A/L needs to be in contact with Surgeon due to severity and potential progression of symptoms

④ Cuff Class 4 symptoms may be secondary to Type 2 DCS which is a medical emergency. Unstowing the resuscitator enables IV crew to be prepared to administer CPR, if reqd. Because it is critical to repress a Class 4 quickly, this may result in a one crewmember repress

⑤ This decision block determines whether the cabin is being operated within 10.2 psi control range. Minor fluctuations above 10.6 have been seen; therefore, 11 psi was used to cover all 10.2 scenarios. Otherwise, cabin is being controlled at 14.7 psi

DCS PROC

## 19.1 (Cont)

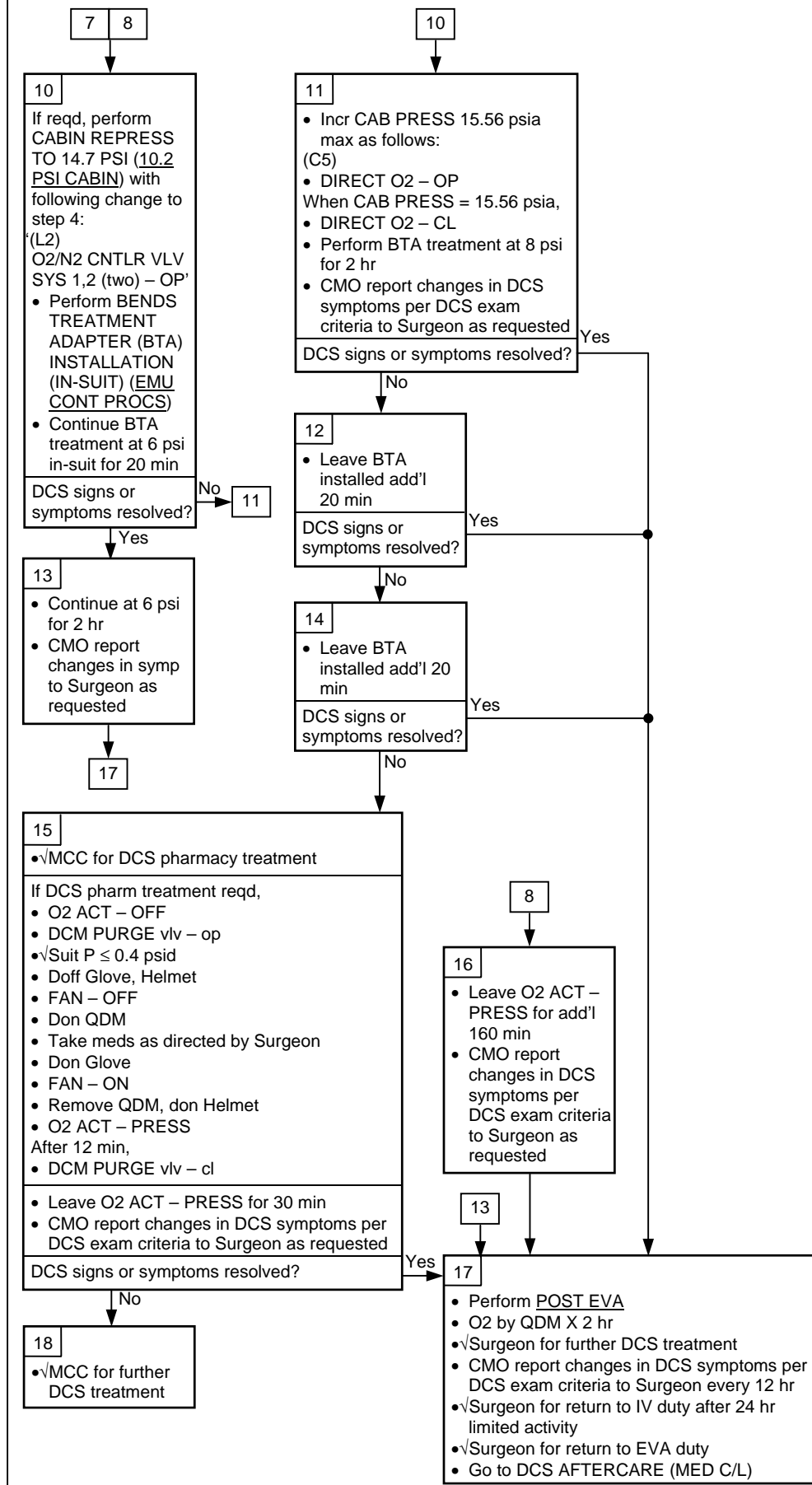

## 19.1 (Cont)

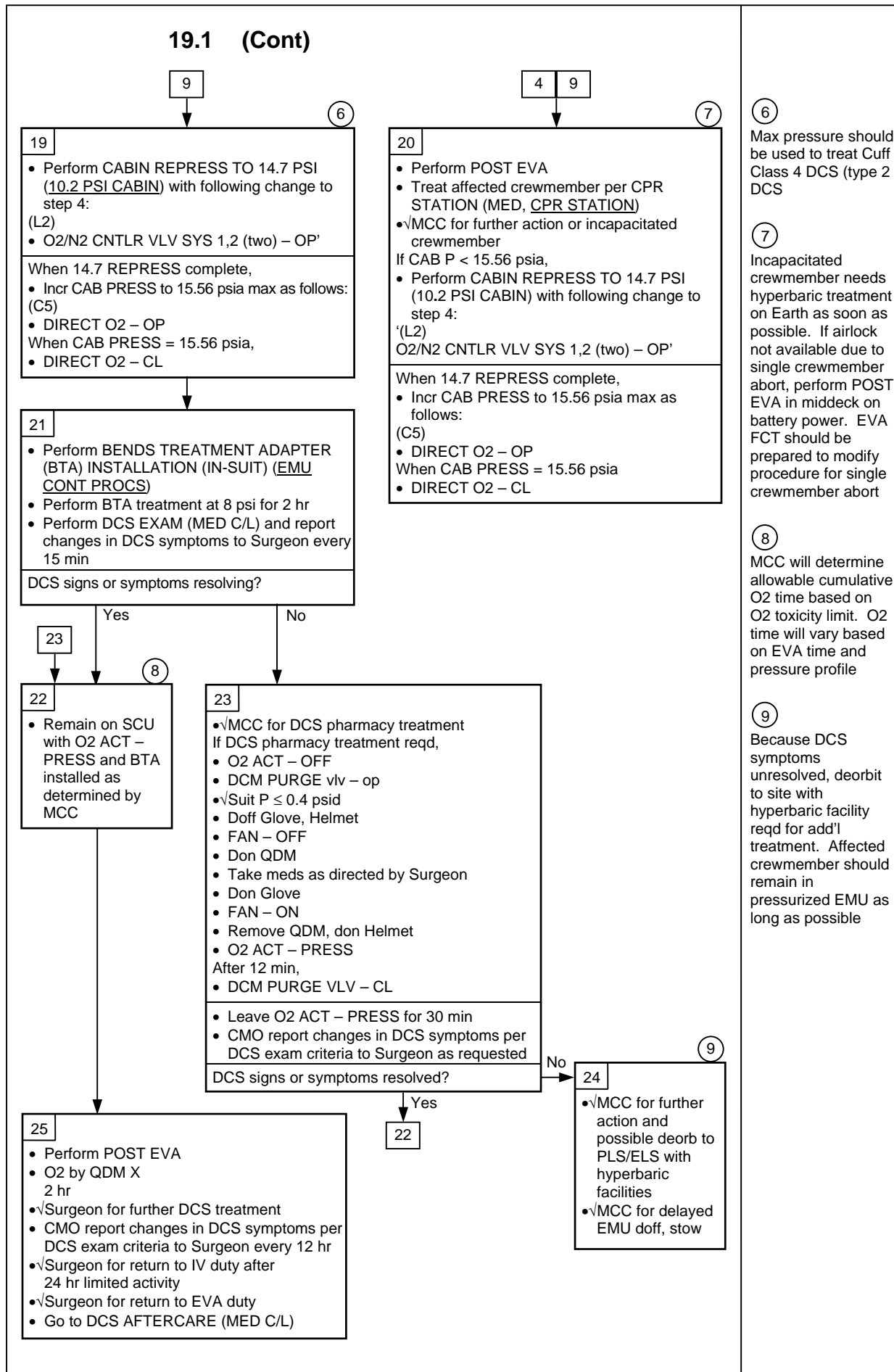

# CONTINGENCY SHUTTLE AIRLOCK INGRESS FROM ISS

CONT  
A/L INGRESS

## CREWLOCK EGRESS

- If EV hatch closed and  $\Delta P < 0.5$  psi:
- EV 1.  $\checkmark$ Tethers connected to crewlock D-ring, open EV hatch, stow
  - 2. Perform POST DEPRESS steps as reqd on CREWLOCK DEPRESS/REPRESS CUE CARD (SODF: ISS EVA SYS: EVA PREP/POST)
  - EV1 3. Open thermal cover, egress crewlock
  - EV2 4. Configure safety tethers for EV1 and EV2,  $\checkmark$ locked
  - 5. Egress crewlock, close thermal cover

## SHUTTLE AIRLOCK PREP

### NOTE

EV1 will translate to prep and open shuttle airlock hatch while EV2 remains to close ISS crewlock hatch after shuttle hatch is open

- EV1 6. Retrieve two external spare safety tethers
- 7. Translate to shuttle airlock stopping at PMA/shuttle interface
- 8. Attach load alleviating strap of EV2 spare safety tether on shuttle side
- 9. Attach EV1 spare safety tether to shuttle, swap to spare safety tether
- 10. Stow ISS safety tether on ISS side
- 11. Retrieve EV2 safety tether anchor hook, attach to mini-workstation, continue to Ext A/L Aft Hatch
- IV Aft Hatch MDK 12. Ext A/L Aft Hatch Equal vlv caps (two) – vent, remove caps, stow
- 13. Close Inner Hatch:
  - Position handle to preclosing position per decal
  - Hatch – rotate about hinge and push
  - Handle – ccw to LATCH
  - Lock lever to LOCKED
- EV1 14.  $\checkmark$ Inner Hatch Equal vlvs (two) – OFF, caps installed
- EV1 15. Open Ext A/L Aft Hatch thermal cover
- IV 16.  $\checkmark$ MCC for attitude control
- EV1 17. On IV GO: Ext A/L Aft Hatch Equal vlvs (two) – EMER

**IF CABIN DP/DT OR O<sub>2</sub>(N<sub>2</sub>) FLOW HI ALARM DURING AIRLOCK DEPRESS**  
EV crew: Ext A/L Aft Hatch Equal vlvs (two) – OFF  
IV crew: Verify Inner Hatch closed and Inner Hatch Equal vlvs (two) – OFF

- EV1 18. Monitor Ext A/L Aft Hatch  $\Delta P$  gauge  
When  $\Delta P < 0.5$  psi (~10 min), open hatch and ingress A/L, connect waist tether to A/L D-ring
- EV1 19. Give EV2 GO for closing ISS crewlock EV Hatch
- 20. Connect anchor hook of EV2 spare safety tether to A/L D-ring

## SHUTTLE AIRLOCK INGRESS

- EV2 21. Open ISS crewlock thermal cover
- 22. On EV1 GO, close ISS crewlock EV Hatch:
  - Verify hatch clear of FOD and obstructions
  - EV hatch handle – preclose
  - Handle – cw to LATCH
  - Lock lever to LOCKED
  - Close thermal cover
- 23. Translate to PMA/shuttle interface

- 24. Swap to spare safety tether, stow ISS safety tether on ISS side
- 25. Retrieve EV1 safety tether anchor hook, attach to mini-workstation
- 26. Translate to shuttle airlock, ingress
- 27. Close thermal cover
- BOTH 28. Retrieve, position SCU; remove DCM cover
- 29. Connect SCU to DCM, √locked
- AW82B 30. EV-1, EV-2 O2 vlv (two) – OP
- BOTH 31. WATER – OFF (fwd)

**CAUTION**  
Do not close hatch until EMU WATER – OFF for 2 min

- 32. √Ext A/L Aft Hatch clear of FOD and obstructions, close hatch:  
 Position handle to preclosing position per decal  
 Hatch – rotate about hinge and push  
 Handle – ccw to LATCH  
 Lock lever to LOCKED
- 33. Ext A/L Aft Hatch Equal vlvs (two) – OFF, install caps
- IV 34. Go to PRE-REPRESS/REPRESS (DEPRESS/REPRESS  
 Cue Card)



CUE CARD CONFIGURATION

Refer to the following pages for cue cards and decals in this document:

- CC 3-10 SAFER CHECKOUT RESULTS Cue Card
- CC 3-11 SAFER STATUS TROUBLESHOOTING Cue Card
- CC A6-2 DEPRESS/REPRESS Cue Card (Nominal Config)
- CC B6-2 DEPRESS/REPRESS Cue Card (Tunnel Adapter)
- CC 6-4 FAILED LEAK CHECK Cue Card
- 19-4 EMERGENCY AIRLOCK REPRESS Decal

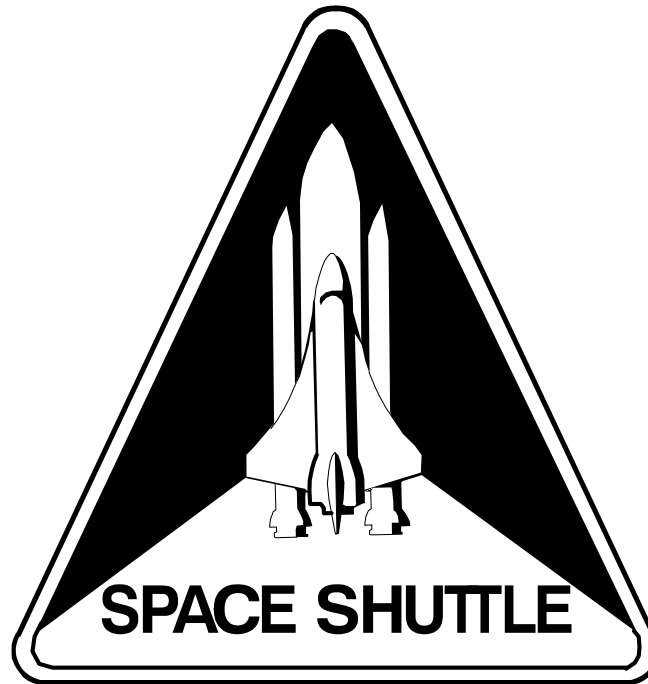

<b>EVA CHECKLIST</b>	<b>STS ALL</b>
--------------------------	--------------------