

Schematic Displays for the Space Shuttle Orbiter Multifunction Cathode-Ray-Tube Display System

(NASA-TM-58206) SCHEMATIC DISPLAYS FOR THE
SPACE SHUTTLE ORBITER MULTIFUNCTION
CATHODE-RAY-TUBE DISPLAY SYSTEM (NASA)
337 p HC A15/MF A01

N79-21122

CSCL 09C

Unclas

63/19

17288

William Weiss
Lyndon B. Johnson Space Center

March 1979



NASA

National Aeronautics and
Space Administration

Lyndon B. Johnson Space Center
Houston, Texas

NASA Technical Memorandum 58206

Schematic Displays for the Space
Shuttle Orbiter Multifunction
Cathode-Ray-Tube Display System

William Weiss

March 1979

NASA

CONTENTS

Section	Page
SUMMARY	1
INTRODUCTION	1
DESIGNING THE SCHEMATIC DISPLAYS	5
The Matrix of Relationships	6
The Overall Schematic Diagram	8
The Theoretical Displays	10
The Practical Displays	13
COSTS	21
Memory Costs	22
Time Costs	24
CONCLUSION	25
APPENDIX A - JUSTIFICATION FOR USING SCHEMATIC DISPLAYS	281
APPENDIX B - GUIDELINES FOR DESIGNING SCHEMATIC DISPLAYS	303
APPENDIX C - ACRONYMS AND ABBREVIATIONS	317
REFERENCES	321

TABLES

Table		Page
1	SPACELAB MASTER COMMAND FUNCTION LIST	26
2	SPACELAB MASTER MEASUREMENT LIST	
	(a) Subsystem S03: control and data management subsystem . .	33
	(b) Subsystem S04: system activation and monitoring/ common payload support equipment/structure	44
3	COST OF FEATURES OF DISPLAYS IN A DYNAMIC ENVIRONMENT	45
4	SCHEMATIC DISPLAY WITH LABELS AND TUTORIALS	46
5	MMU SCHEMATIC DISPLAY WITHOUT LABELS AND TUTORIALS	47
6	MMU TABULAR DISPLAY	47
A-1	EXPERIMENT 1 RESULTS	293
A-2	EXPERIMENT 2 RESULTS	294
B-1	LIMITATIONS ON THE VARIOUS CODING DIMENSIONS NORMALLY AVAILABLE	315

FIGURES

Figure		Page
1	CDMS block diagram	48
2	CDMS overview	49
3	The matrix of relationships	51
4	Expanded-matrix elements	
	(a) 1,1 and 2,2	52
	(b) 2,4 and 2,13	53
	(c) 3,3 and 3,5	54
	(d) 3,13 and 4,4	55
	(e) 4,6 and 5,5	56
	(f) 5,6 and 6,6	57
	(g) 7,7 and 7,25	58
	(h) 7,38 and 8,9	59
	(i) 8,10 and 9,10	60
	(j) 9,27 and 9,40	61
	(k) 10,27 and 10,40	62
	(l) 11,11 and 11,19	63
	(m) 11,29 and 11,42	64
	(n) 12,12 and 12,13	65
	(o) 12,23 and 12,36	66
	(p) 13,13 and 13,23	67
	(q) 13,36 and 14,15	68
	(r) 14,16 and 14,20	69
	(s) 14,22 and 14,28	70
	(t) 14,41 and 15,15	71
	(u) 15,17 and 16,16	72
	(v) 16,16 and 17,17	73
	(w) 18,26 and 18,39	74
	(x) 20,22 and 23,23	75
	(y) 23,30 and 24,24	76
	(z) 24,30 and 24,32	77
	(a') 25,25 and 25,30	78
	(b') 26,26 and 26,30	79
	(c') 27,27 and 27,30	80
	(d') 28,28 and 28,30	81
	(e') 29,29 and 29,30	82
	(f') 30,30 and 30,45	83
	(g') 30,47 and 32,32	84
	(h') 33,33 and 33,37	85
	(i') 34,34 and 34,37	86
	(j') 35,35	87

Figure		Page
4	(k')	35,37 and 36,36 88
	(l')	36,43 and 37,37 89
	(m')	37,43 and 38,38 90
	(n')	38,43 and 39,39 91
	(o')	39,43 and 40,40 92
	(p')	40,43 and 41,41 93
	(q')	41,43 and 42,42 94
	(r')	42,43 and 43,43 95
	(s')	43,47 and 43,49 96
	(t')	45,45 and 45,46 97
	(u')	46,46 and 47,47 98
	(v')	47,48 and 48,48 99
	(w')	49,49 and 49,50 100
	(x')	50,50 101
5	The overall CDMS schematic diagram 102	
6	Theoretical CDMS schematic displays	
	(a)	1,1 103
	(b)	2,2 104
	(c)	2,4 105
	(d)	2,13 106
	(e)	3,3 107
	(f)	3,5 108
	(g)	3,13 109
	(h)	4,4 110
	(i)	4,6 111
	(j)	5,5 112
	(k)	5,6 113
	(l)	6,6 114
	(m)	7,7 115
	(n)	7,25 116
	(o)	7,38 117
	(p)	8,9 118
	(q)	8,10 119
	(r)	9,10 120
	(s)	9,27 121
	(t)	9,40 122
	(u)	10,27 123
	(v)	10,40 124
	(w)	11,11 125
	(x)	11,19 126
	(y)	11,29 127
	(z)	11,42 128
	(a')	12,12 129
	(b')	12,13 130
	(c')	12,23 131
	(d')	12,36 132
	(e')	13,13 133

Figure		Page
6	(f') 13,23	134
	(g') 13,36	135
	(h') 14,15	136
	(i') 14,16	137
	(j') 14,20	138
	(k') 14,22	139
	(l') 14,28	140
	(m') 14,41	141
	(n') 15,15	142
	(o') 15,17	143
	(p') 16,16	144
	(q') 17,17	145
	(r') 18,26	146
	(s') 18,39	147
	(t') 20,22	148
	(u') 23,23	149
	(v') 23,30	150
	(w') 24,24	151
	(x') 24,30	152
	(y') 24,32	153
	(z') 25,25	154
	(a'') 25,30	155
	(b'') 26,26	156
	(c'') 26,30	157
	(d'') 27,27	158
	(e'') 27,30	159
	(f'') 28,28	160
	(g'') 28,30	161
	(h'') 29,29	162
	(i'') 29,30	163
	(j'') 30,30	164
	(k'') 30,45	165
	(l'') 30,47	166
	(m'') 32,32	167
	(n'') 33,33	168
	(o'') 33,37	169
	(p'') 34,34	170
	(q'') 34,37	171
	(r'') 35,35	172
	(s'') 35,37	173
	(t'') 36,36	174
	(u'') 36,43	175
	(v'') 37,37	176
	(w'') 37,43	177
	(x'') 38,38	178
	(y'') 38,43	179
	(z'') 39,39	180
	(a''') 39,43	181
	(b''') 40,40	182
	(c''') 40,43	183

Figure		Page
6	(d''') 41,41	184
	(e''') 41,43	185
	(f''') 42,42	186
	(g''') 42,43	187
	(h''') 43,43	188
	(i''') 43,47	189
	(j''') 43,49	190
	(k''') 45,45	191
	(l''') 45,46	192
	(m''') 46,46	193
	(n''') 47,47	194
	(o''') 47,48	195
	(p''') 48,48	196
	(q''') 49,49	197
	(r''') 49,50	198
	(s''') 50,50	199
7	Symbol definition for expanded-matrix parameters	
	(a) Toggle switch	200
	(b) Rotary switch	200
	(c) Electrical	200
	(d) Temperature	201
	(e) Load	201
	(f) Power network	202
	(g) Phosphor protection	202
	(h) Motor	202
	(i) HRDR tape	202
	(j) DPS control	202
8	Roll-in technique	203
9	Index display	204
10	SS COMP activation flow chart	205
11	SS COMP activation displays	
	(a) Initial display	206
	(b) Concluding display	207
12	SS COMP monitoring and controlling flow chart	208
13	SS COMP monitoring and controlling displays	
	(a) Initial display	209
	(b) Concluding display	210
14	SS COMP deactivation flow chart	211

Figure	Page
15 SS COMP deactivation display	212
16 SSI0 activation flow chart	213
17 SSI0 activation display	214
18 SSI0 monitoring and controlling flow chart	215
19 SSI0 monitoring and controlling display	216
20 SSI0 deactivation flow chart	217
21 SSI0 deactivation display	218
22 HRDR activation flow chart	219
23 HRDR activation display	220
24 HRDR monitoring and controlling flow chart	221
25 HRDR monitoring and controlling display	222
26 HRDR deactivation flow chart	223
27 HRDR deactivation display	224
28 MMU activation flow chart	225
29 MMU activation display	226
30 MMU monitoring and controlling flow chart	227
31 MMU monitoring and controlling display	228
32 MMU deactivation flow chart	229
33 MMU deactivation display	230
34 DDU/KB activation flow chart	231
35 DDU/KB activation display	232
36 DDU/KB monitoring and controlling flow chart	233
37 DDU/KB monitoring and controlling display	234
38 DDU/KB deactivation flow chart	235
39 DDU/KB deactivation display	236

Figure	Page
40 SS RAU's activation flow chart	237
41 SS RAU's activation display	238
42 SS RAU's monitoring and controlling flow chart	239
43 SS RAU's monitoring and controlling display	240
44 SS RAU's deactivation flow chart	241
45 SS RAU's deactivation display	242
46 EXP COMP activation flow chart	243
47 EXP COMP activation displays	
(a) Initial display	244
(b) Concluding display	245
48 EXP COMP monitoring and controlling flow chart	246
49 EXP COMP monitoring and controlling displays	
(a) Initial display	247
(b) Concluding display	248
50 EXP COMP deactivation flow chart	249
51 EXP COMP deactivation display	250
52 EXPPIO activation flow chart	251
53 EXPPIO activation display	252
54 EXPPIO monitoring and controlling flow chart	253
55 EXPPIO monitoring and controlling display	254
56 EXPPIO deactivation flow chart	255
57 EXPPIO deactivation display	256
58 BU COMP activation flow chart	257
59 BU COMP activation displays	
(a) Initial display	259
(b) Switchover from SS COMP	260
(c) Switchover from EXP COMP	261

Figure		Page
60	BU COMP monitoring and controlling flow chart	262
61	BU COMP monitoring and controlling display	
	(a) Initial displays	264
	(b) BU COMP performing SS functions	265
	(c) BU COMP performing EXP functions	266
62	BU COMP deactivation flow chart	267
63	BU COMP deactivation display	268
64	RAAB activation flow chart	269
65	RAAB activation display	270
66	RAAB monitoring and controlling flow chart	271
67	RAAB monitoring and controlling display	272
68	RAAB deactivation flow chart	273
69	RAAB deactivation display	274
70	MMU schematic displays with labels and tutorials	
	(a) Activation	275
	(b) Monitoring and controlling	276
	(c) Deactivation	277
71	Test to display symbol solid or dashed	278
72	MMU schematic display without labels and tutorials	279
73	MMU tabular display	280
A-1	DPS configuration monitor	296
A-2	Hypothetical variation of DPS configuration monitor	297
A-3	Organization of GPC's, data buses, and MDM's	298
A-4	The four possible modes of the strings	299
A-5	Example of tabular mode indication	299
A-6	Format of the pictorial display	300
A-7	Visual coding in the pictorial displays of the four possible string modes	300

Figure		Page
A-8	Example of pictorial mode indication	301
A-9	Example of pictorial RS indication	301
A-10	Visual coding in the tabular displays of the string modes	302

SUMMARY

The dominating element of the Space Shuttle Orbiter crew/machine interface is the multifunction cathode-ray-tube display system. The display units have some very powerful graphics capabilities; however, all the systems management displays designed for the orbital flight tests are arranged in a tabular format. This arrangement does not take advantage of the advanced graphics system available and may not be the most efficient means of providing crewmembers with status and configuration information related to the various subsystems. This document describes the techniques and procedures developed for designing sets of schematic displays, the software costs associated with implementing sets of schematic displays, the experimental and theoretical background data supporting the use of schematic formats for displaying subsystems information, and the guidelines to be followed in designing sets of schematic displays.

In a cost analysis of one of the displays, the schematic version required 15 percent less general-purpose-computer memory than the corresponding tabular version. In addition, it was determined that a schematic display presenting information related to an aspect of a subsystem requires significantly less central-processing-unit time for processing the code associated with it than a corresponding tabular display presenting information related to the entire subsystem.

INTRODUCTION

Many experiments performed in the past have indicated that data presented in a pictorial format are superior for both recall and recognition tasks to data presented in a word format. These experiments ranged from elaborate, precisely controlled procedures involving the display of sequences of thousands of pictures to much more abstract experiments in which subjects were instructed to form mental images of words or phrases and then later were asked to perform recall or recognition tasks. Two experiments were performed to further verify the concept of using schematic subsystems management displays and to obtain data from experiments more closely approximating use of the multifunction cathode-ray-tube (CRT) display system (MCDS). In both experiments, the subject's task involved obtaining information from sets of simulated CRT displays and executing keystrokes on a simulated MCDS keyboard in response to the information obtained. Levels of performance attained with sets of tabular and schematic displays were compared, together with that for a set of control displays. The results of these two experiments support the general concept that the learning curves for schematic displays level off at a higher value than the learning curves for equivalent tabular displays.

A technique has been developed for conveniently indexing the units of any subsystem and the relationships existing between those units. This index takes the form of a symmetric matrix, the rows and columns of which are labeled by the units of the subsystem. The elements of the matrix contain the relationships between the units of the subsystem. When the matrix is completed, it provides a comprehensive index of every unit in the subsystem being considered and every relationship existing between the units of the subsystem. An important aspect of the matrix is that it enables a view of the subsystem without an implication of any hierarchical order. The importance of this aspect becomes apparent in a later stage of the analysis, when a cross section of the subsystem is taken to provide the required information in an organization appropriate for the types of functions to be performed with use of the displays. It is these functions that will determine what aspects of the subsystem are to be considered most important. However, before the cross section is taken, there are several steps to be performed.

From the matrix, it is possible to construct an overall schematic diagram of the subsystem. This schematic diagram should contain a great deal of geometric and spatial coding. When the actual shape and physical locations of the units of the subsystem can be mentally imaged by the crewmembers, the geometric and spatial coding used in the diagram should correspond to the approximate shapes and approximate relative locations of the actual units of the subsystem. Geometric and spatial coding can also aid in the imaging of units of the subsystem that might otherwise not produce a strong mental image, and thus increase the ability of a crewmember to recall status and configuration information related to any of the units of the subsystem. Geometric and spatial coding in the diagram might also correspond to already designed or existing hard-wired control panels; but, most importantly, it should correspond to any schematic diagrams used for crew training. However, this latter correspondence could remain somewhat dynamic, because a training emphasis on simulations would eventually result in a crewmember's regarding the schematic diagram from which the displays were designed as the schematic diagram of the subsystem, regardless of whether it corresponded to the training schematic diagram. Of course, if the training and display schematic diagrams are designed together, they can contain the same geometric and spatial coding, the result of which is that very little mental recoding will have to be done by the crewmembers. With use of the schematic diagram and the matrix as a base, it is possible to design a set of theoretical displays. The design of these displays would be based on the theory that there should be one logical thought on each display. One display would be designed for each element of the matrix. Therefore, for these displays, the one logical thought expressed on each display would be the comprehensive understanding of the relationships existing between two specific units of the subsystem being considered. These displays would also maintain the geometric and spatial coding used in the overall schematic diagram of the subsystem. However, several problems would make these theoretical displays impractical to implement. Because the display designer would not control the amount of information to be coded onto each display, the displays would often turn out either too dense or too sparse. Because the display designer also would not control the nature of the information to be presented on each display, the displays might not convey their information in a manner most applicable to the tasks to be performed. Because there would be one display for each element of the matrix, for a subsystem

with N units identified, there could be as many as $(N^2 + N)/2$ displays. Even if only a small percentage of the matrix elements contained information, there would still be an unacceptably large number of theoretical displays. However, the theoretical displays remain an essential aspect of the development scheme because they provide a base from which a set of practical displays can be designed.

The objective would be to determine a scheme for combining the theoretical displays to form practical displays. The major factor to be considered in this respect would be the specific tasks for which the displays are to be used. The choosing of appropriate combinations of theoretical displays is, essentially, the selection of a cross section of the subsystem that best illustrates the aspects of that subsystem that must be dealt with in performing the tasks for which the displays are to be used. This cross sectioning of a subsystem may result in the design of a set of schematic displays that is not unlike a geographical atlas in organization, a type of hierarchical structure. The first display in the hierarchy might be a general overview of the subsystem being examined, just as the first page in an atlas of the United States might be a spacecraft photograph of the entire United States, as general a map as possible. As a user moves down in the hierarchy of displays, the information accessed could be more detailed in two senses. In relation to the display directly above it, the current display might focus in on a smaller section of the subsystem being examined but provide information related to as many aspects as the previous display. Subsequent pages in the atlas might contain spacecraft photographs of various regions of the United States, general information but related to smaller areas. On the other hand, a more detailed display might provide information across as much of the subsystem as the display directly above it in the hierarchy but might focus in on one particular aspect of the subsystem. Other pages in the atlas might contain maps of the entire United States, but provide information related to specific aspects of U.S. geography, such as political boundaries, rainfall data, crop production, railroad lines, or population data. At this point, the importance of the lack of hierarchical implications in the matrix, the overall schematic diagram, and the theoretical displays becomes apparent. The theoretical displays should not contain any implications as to which units of the subsystem are most important, because it is only after the tasks for which the displays are to be used are known that it can be determined which aspects of the subsystem are to be considered most important.

There is an additional major advantage to using sets of schematic displays for crew training. When a crewmember first encounters the set of displays to be used to perform a task associated with a particular subsystem, displays can be provided that contain an extensive amount of labeling and a large number of tutorial messages in addition to the geometric coding. However, these added factors present an unusual problem. The MCDS screens are quite small. Even the small alphanumeric characters are large in relation to the screen because the characters must be easily readable during ascent and entry phases, at which times crewmembers will be strapped into their couches. However, during the on-orbit phase - which is when these schematic displays would be used - and especially when operating from the aft flight deck, these restrictions would not exist. Without producing any clutter, much denser schematic displays with much smaller symbols and characters for labeling and tutorials would be perfectly acceptable and actually quite desirable because

it is easier for an operator to look at another region of the same display than to call up a new display when additional information is required. The problem presented is that the relatively large size of the characters that must be used for labeling and tutorials greatly limits the size of the geometric symbols used. However, it probably would not take very long for a crewmember to learn all the geometric and spatial coding used in the displays well enough that the labels would not be needed, and to become familiar enough with the procedures that the tutorials would not be needed. Actually, when a crewmember is very familiar with a set of displays, the labels and tutorials might even be considered clutter. Removing most of the characters from the displays solves the problem of not being able to use small symbols and, therefore, denser displays. Perhaps even more important, if the flight version of a set of displays contains a minimal amount of labeling and tutorial information and there are fewer, denser displays, the cost in the flight software will be drastically reduced from what it would be if the labels and tutorials were used. It is even expected that these denser schematic displays that contain a minimum amount of labeling and no tutorials would have a general-purpose-computer (GPC) memory cost less than that for the equivalent tabular displays. There could always be a hard-copy page or even a separate CRT display that would indicate what each symbol represents in the event that a crewmember does not remember exactly what a symbol means. The software cost associated with programming in the labels and tutorials for initial training is not important, because the functional simulators do not even use flight software. The GPC memory cost advantage of using schematic displays can now be seen more clearly. The labels can never be removed from a tabular display; if they were, there would be no reasonable method by which a crewmember could determine the identification of the parameters being viewed.

There is an additional cost advantage associated with using schematic displays. If all the required information related to a subsystem cannot be coded onto one display page, it is possible to use a programming technique that will allow as many displays as will fit in the GPC buffer at one time to be coded so that they appear to the cyclic processor to be one display. Only one item-number table would be used, and sequencing through the displays would be accomplished by executing item numbers. Because the cyclic processor would only execute the code associated with generating the format control words (FCW's) required to display one page - branching past all the code for the other pages in the buffer - and because the amount of code corresponding to a schematic display that provides information related to an aspect of a subsystem would be far less than the code corresponding to a comprehensive tabular display that provides information related to that same subsystem, there would be far less central-processing-unit (CPU) time required for displaying each schematic display than for displaying each tabular display.

The main body of this document presents the set of schematic displays designed and describes the techniques and procedures used to design it and the costs that would be encountered in implementing sets of schematic displays. Appendix A describes the experimental and theoretical background data that support the concept of using schematic formats for displaying subsystems information. Appendix B contains the guidelines that should be followed in designing sets of schematic displays. Appendix C contains the definitions of the acronyms and abbreviations used in this document.

DESIGNING THE SCHEMATIC DISPLAYS

If the advantages of using schematic displays are to be fully utilized, it is necessary to develop standard procedures for designing the displays. In addition, because some subsystems are extremely complicated, the use of non-standard procedures could easily make the task of designing the displays for those subsystems much more difficult than it has to be. It could also result in additional difficulties in documenting the work that has been done, with respect to the capability of more than one person to easily work on the design of a set of displays at one time or to pick up easily where someone else left off. There is another advantage to using standard procedures. Ideally, the schematic displays for all the subsystems of a vehicle should be designed at the same time. This would be an extremely complicated task in which the use of standard procedures would be even more important than in the designing of schematic displays for one subsystem at a time. Of course, certain characteristics of the subsystem for which the displays are being designed and of the display system that will be used to present the displays, the MCDS in the case of the Space Shuttle Orbiter, will result in the necessity to deviate from the standard procedures established. However, these deviations should be held to a minimum and should be very well documented when they occur so that anyone who needs to can determine precisely why these deviations exist.

This section contains the description of the standard procedures that have been developed. As an example, a step-by-step description of the design of a set of schematic displays that would provide information related to a typical subsystem - the Spacelab command and data management subsystem (CDMS) - to be monitored and controlled by means of the MCDS is given.

Consider the CDMS. It will be activated, deactivated, and possibly monitored and controlled with use of the MCDS as the crew/CDMS interface. The CDMS is illustrated in figures 1 and 2. The CDMS is used to monitor and control the Spacelab subsystems and experiments. There are three computers. The subsystems computer (SS COMP) interfaces to the subsystems, the experiments computer (EXP COMP) interfaces to the experiments, and the backup computer (BU COMP) interfaces to either the subsystems or experiments in the event that a failure occurs. The computers interface to the various units that they monitor and control through two types of input/output (I/O) units, subsystem remote acquisition units (SS RAU's) and experiment remote acquisition units (EXP RAU's). The two types of I/O units are internally dual redundant, with redundancy occurring at the coupler level. The subsystem I/O unit (SSIO) can be linked to either the SS COMP or the BU COMP, whichever is handling the subsystems. Similarly, the experiments I/O unit (EXPIO) can be linked to either the EXP COMP or the BU COMP. In addition to interfacing to their respective RAU's, the two I/O units each interface to the Spacelab's three data display units and keyboards (DDU/KB's), the Spacelab's mass memory unit (MMU), the Orbiter's pulse code modulation master unit (PCMMU), the Orbiter's two payload multiplexer/demultiplexers (MDM's) (PF1 and PF2), the Spacelab's high-rate multiplexer (HRM), and the Spacelab's remote amplifier and advisory box (RAAB). There are other important units and links that will be discussed as the description of the analysis of the CDMS progresses.

The Matrix of Relationships

The first step in the analysis of a subsystem is the construction of a matrix that is, in effect, an index of all the relationships existing within that subsystem. The matrix for the CDMS is illustrated in figure 3, and the expanded-matrix elements are detailed in figure 4. The rows and columns of the matrix are labeled by the units of the subsystem determined to be important in respect to the task that will be performed with use of the schematic displays eventually to be derived from the matrix. The units may be either hardware or software components. They can be identified by accessing a wide variety of sources. For the CDMS, the major sources of information used to identify units were two schematic diagrams, illustrated in figures 1 and 2, and the CDMS section of the master command and measurement list, shown in tables 1 and 2.

Determining which features of a subsystem should be considered as units and thus be given a row and column in the matrix can be very difficult. It is not advisable to spend a great deal of effort in doing this. If there is any suspicion that a feature might be important, then it should be entered into the matrix. If it turns out later that it is not important, then no entries will appear in that unit's row or column and it can be deleted from the matrix with no difficulty. An example are rows and columns 21, 31, and 44, which are labeled "Not used." On the other hand, if an important unit is left out, then the subsequent analysis may become somewhat forced and inaccurate when an attempt is made to compensate for the missing unit. For example, consider a hypothetical computer system in which a CPU controls the operation of a tape drive by means of a hardware channel. Suppose that initially, the channel is not considered a unit of the system and is left out of the matrix, with the understanding that it is really the CPU that is constructing the channel program that controls the tape drive. This may work very well until later in the analysis when it is discovered that commands that turn the channel on and off must be incorporated into the displays being designed. Now the channel must be added as a unit, into the matrix, and all the links that should have included the channel, and did not, must be changed to correctly indicate linkage to the channel.

The matrix is symmetric. Therefore, only the upper or lower triangular half and the principal diagonal need to be filled in. Any entry off the principal diagonal corresponds to a relationship existing between the units that label the entry's row and column. Any entry on the principal diagonal indicates that the relationship it represents corresponds to an internal aspect of the one unit that labels its row and column. In the CDMS matrix illustrated in figure 3, the different types of relationships are coded with monochrome letters because it was not possible to reproduce colors in this document. The original matrix actually used in the analysis of the CDMS had color-coded letters. The addition of a color dimension made it possible to very quickly and easily determine any patterns existing in the matrix.

Although the letter codes used in the matrix indicate the types of relationships that exist between the various units of the CDMS, they do not specify exactly what those links are. For example, at location (5,6) in the matrix, there is an indication that a software command exists that has some effect on

the link between the EXPIO and the BU COMP. However, there is no indication as to what that command actually is. For this reason, the matrix is really only an index to an index. Each element of the matrix is expanded into a full page that indicates precisely what links the letter codes stand for. This detailed index is presented in figure 4. Upon turning to page (5,6) in the index, it is possible to determine that the C at element (5,6) in the matrix represents a command that turns the BU COMP power on and then links the BU COMP to the EXPIO.

Any type of information can be stored in the expanded matrix. As with determining which units should be entered into the matrix, if it is not known whether some specific information will be needed or not, it is much better to enter it into the matrix than to leave it out. There is no rule indicating that all the information in the matrix must be incorporated into the final displays designed; however, if information is omitted and then later found to be necessary, a great deal of backtracking might have to be done to obtain that information. For example, each command and measurement that was obtained from the master command and measurement list contains a five-parameter subscript at the end. The last four parameters indicate the routing of this information, as determined by the Spacelab configuration being flown: The first parameter corresponds to the short-module-with-three-pallets configuration, the second corresponds to the long-module configuration, the third corresponds to the five-pallet configuration, and the fourth corresponds to the three-pallet configuration. Because the displays that were designed are intended to be an example of what schematic Spacelab displays could be like, and not to be displays for a specific Spacelab configuration, the information related to the Spacelab configurations was not used. However, if at some later time it was needed, it would be easily accessible.

Although the information stored in the expanded matrix may be in any format, it is suggested that a standard format for each type of information be chosen. There are two major reasons for doing this: First, the use of standard formats will greatly reduce the probability that someone will misinterpret information entered into the expanded matrix by someone else; second, the use of standard formats will greatly facilitate any later attempt to store the matrix in files that can be accessed by a computer. It would certainly be possible to develop a highly sophisticated system for computer-aided design of displays, one which would allow a display designer to easily access any type of information about any units in any subsystems. However, to make this system feasible, all the information in the matrix would have to be stored in formats that would make a quick-scan operation possible.

It is somewhat difficult to state precisely what the procedure for constructing the matrix for any subsystem should be. The major determining factor will be the nature of the available information about the subsystem. For the CDMS matrix, the first step after obtaining a general understanding of the CDMS was to examine the schematic diagrams illustrated in figures 1 and 2 and attempt to choose the units that seemed important. These units were assigned rows and columns in the matrix. No attempt was made to label the rows and columns in any particular order. The procedures and techniques developed do not require that the rows and columns be labeled in a specific order. However, this is not meant to imply that future refinements in the

procedures might not require some specific order. The CDMS section of the master command and measurement list, presented in tables 1 and 2, was next examined, also in an attempt to specify important units of the CDMS. When this step was finished, completing the labeling of the rows and columns of the matrix, the master command and measurement list was again examined, this time with the intention of entering each of the commands and measurements into the matrix. The schematic diagrams were then examined again to determine the hardware links that should be entered into the matrix. The direct hardware links are indicated by the code "dlb," directly linked by. After this step was completed, other sources were examined for detailed aspects of the CDMS that might become important in designing the displays. For example, a diagram of the Spacelab's DDU/KB will indicate that there is a switch on the KB that will connect to either the SSIO or the EXPIO. Later, it may become important to have one of the displays indicate that there is a switch to perform this function, rather than a software command. Another example is derived from a Spacelab document indicating that the capability will exist to control any of the Spacelab's three DDU's from any of the Spacelab's three KB's. Because there are no switches to perform this function, it was assumed that there would be appropriate software commands, although none appeared in the master command list. These assumed commands were then added into the matrix and were also added to the master command list as possible commands. When all the information has been entered into the matrix, the units originally chosen can be examined to determine if there are any that have no entries in both their rows and columns. If there are, then these units will not be considered important when the displays are designed and they can be removed from the matrix, their rows and columns being labeled "Not used."

In reality, the construction of the matrix will probably not be as simple and relatively straightforward as this description might seem to imply. Constant changes in the subsystem being analyzed will require constant changes in the matrix. In addition, even with the most determined efforts, the addition, deletion, and reorganization of the units of the subsystem represented in the matrix will probably be necessary throughout the analysis.

Despite the effort required to carefully construct the matrix of relationships, the tremendous value that it has necessitates its construction for the successful completion of the procedures required to be performed to design efficient schematic displays.

The Overall Schematic Diagram

The next step in the analysis of the subsystem is construction of an overall schematic diagram to provide a standard basis from which the schematic displays can be designed.

The overall schematic diagram for the CDMS can be seen in figure 5. Three major types of coding exist in the diagram - geometric, spatial, and label.

The geometric coding is extremely important because it provides an immediate indication of the type of unit being viewed. For example, a

circle can be immediately identified as a computer. The trapezoid would be quickly recognized as the voice digitizer (VD). As was suggested in the Introduction, when the actual physical appearance of a unit would provide an additional recall stimulus, the geometric code for the unit should be constructed to resemble that unit's appearance. For example, the DDU/KB symbol is supposed to resemble a CRT and keyboard. The MMU symbol might be recognized as a familiar ground-based tape drive. The high-rate data recorder (HRDR) and the payload recorder (PLRC) both contain double circles, which could represent the two tape reels on a conventional tape recorder. The geometric codes for the experiment rack RAU's, airlock RAU, and pallet RAU's are fairly accurate diagrams of the actual locations of these devices. Notice that with a total of only 12 extra lines, as illustrated in figure 5, it is possible to create simple geometric codes closely resembling the appearance of the Spacelab module and pallet configurations. With a little imagination, the intercom (IC) symbol might represent a small square panel with a round speaker; with a lot of imagination, the master timing unit (MTU) symbol could be seen as an hourglass and the PCMMU symbols could be earthward-pointing antennas. The rest of the symbols were designed with the primary objectives of minimizing the amount of software required to generate them and the probability of causing visual confusion errors. There was no real attempt to provide a strong correspondence between those abstract symbols and the actual appearance of the units represented, because it is unlikely that the actual appearance of those units would aid mental imagery of the subsystem. For example, a view of the Orbiter's forward avionics bays will provide a scene of black boxes, cables, and connectors that defies visual coding. However, the abstract symbols do not preclude the possibility of an eventual construction of additional meanings to the symbols, aside from the obvious visual code specifying that the symbols are the units themselves. For example, an observer who had examined a preliminary version of the overall diagram commented that the circles (representing the computers) at the top of the diagram produced a visual image of the circular (or head-shaped) units of the subsystem being in a high (or commanding) position over the rest of the subsystem. This observer's interpretation of the diagram involves the use of both geometric and spatial coding, spatial coding being the second major type of coding used in the diagram.

In addition to the high degree of geometric coding in the diagram, there is also a great deal of spatial coding. Whereas the geometric coding can be used to easily distinguish between units of different types, the spatial coding can be used to distinguish between units of the same type. For example, a circle would indicate that the unit being examined is one of the three computers. If there are two other circles to the right, then the specific computer is the SS COMP. Although the spatial coding is done somewhat arbitrarily, it is possible to obtain some nonrandom characteristics by using some preliminary knowledge of the subsystem. For example, the computers and I/O units are arranged so that connecting lines could be easily drawn from the BU COMP to either I/O unit, from the SS COMP to the SSIO, and from the EXP COMP to the EXP IO. All the units that interface to only the SSIO, and consequently are controlled by only the SS COMP, were placed directly below the SS COMP. Similarly, those units that interface to only the EXP IO were placed directly below the EXP COMP. Those units that can interface to either I/O unit were placed directly below the BU COMP.

Connect lines entering a unit from the right would be interfaces to the EXPPIO. Lines from the left would come from the SSIO. These connect lines are not actually drawn on the diagram because they would cause too much clutter and, in the case of the CDMS, are not very crucial to any operations that would be performed with use of the displays, and can be easily imaged.

Whenever the actual physical arrangement of the units would be meaningful to crewmembers, it is advisable that the spatial coding approximate the arrangement as closely as possible. In the overall diagram of the CDMS, the only spatial coding having this characteristic is the coding for the experiment RAU's. The rack, airlock, and pallet RAU's are all represented in their approximate relative locations. In addition, as the actual vehicle would be during short-module-with-three-pallets-configuration missions, the Spacelab module is forward of the pallets.

The assignment of geometric codes can remain quite dynamic throughout the entire design period of the displays. It is advisable to find a large blank wall, draw large symbols on individual sheets of paper, and attach those symbols to the wall in their relative locations by using a method that will allow the symbols to be easily removed from one location on the wall and placed in another.

With the high degree of geometric and spatial coding that exists in the diagram, the label coding actually provides redundant coding. The labels are essentially the acronyms and abbreviations of the corresponding units of the subsystem, although a few concessions were made to minimize the number of characters in some of the labels. Although the labels are an important aspect of the overall diagram, they have several characteristics, which will be discussed later, that make it advantageous to hold their use to an absolute minimum in designing the final, flight version of the schematic displays.

The Theoretical Displays

From the overall diagram of the CDMS, it is possible to design a set of theoretical schematic displays that will provide a basis from which a set of practical schematic displays can be designed.

Engel and Granda (ref. 1) indicate that a single display should present one logical thought. Of course, it can be difficult to define precisely what a logical thought is; however, one possibility is that a logical thought is the understanding either of the status of a specific unit of a subsystem or the relationships existing between two specific units of a subsystem. Because each element on the principal diagonal of the matrix contains information related to the status of a unit, and because each element off the principal diagonal contains information corresponding to the relationships existing between two units, a reasonable set of theoretical displays can be constructed by incorporating the information contained in an element of the matrix into one schematic display. That is, there exists a one-to-one correspondence between the elements of the matrix - each of which is a page

in the expanded matrix - and the theoretical displays. The set of theoretical schematic displays for the CDMS is presented in figure 6.

The geometric, spatial, and label coding in the theoretical displays is identical to the coding used in the overall schematic diagram. However, because a major effort must be made to avoid wasting significant amounts of space in the practical displays that would actually be implemented, it is not possible to provide any size coding in the displays. The relative sizes of the units in the theoretical displays are not important. A unit can be drawn in any size that conveniently fits it onto the theoretical display. However, as will become apparent, fitting a unit onto a practical display while attempting to maintain its geometric shape and its position relative to the other units on the display without exceeding the physical boundaries of the CRT screen can be a nontrivial problem.

Because the overall schematic diagram does not present any information related to the status of each unit of the subsystem or of any of the nonpermanent links existing between units of the subsystem, it is necessary to develop standard codes for use in displaying the status parameters indicated in the expanded matrix. Figure 7 illustrates and describes the symbols that are used. Whenever possible, although an attempt is made to keep the number of lines used to form each symbol to a minimum, the symbols are designed to be similar to some visual code that might normally be associated with the general nature of the parameter being displayed.

Several line codes are used that are not explicitly indicated in the theoretical displays but, rather, are implied by the symbols being used and by the entries occurring in the expanded matrix. Because any unit of the subsystem may be either on or off, the lines comprising its symbol may be driven either solid or dashed, respectively. Because any data path, with the exception of those explicitly indicated on the overall diagram, may be either established or not established, the line representing it may be driven either solid or dashed, respectively. The expanded matrix contains built-in test equipment (BITE) measurements for some of the units of the subsystem. For those units, there exists the capability to drive the display of a symbol representing a failed unit either overbright or flashing, although, as discussed in part (c) of figure 7, overbright might be a slightly better choice because it would not be as distracting as flashing and would still command attention.

Throughout all the displays, the capital letter X is used to indicate a parameter that would only be known when the displays were actually implemented. There are two major uses of the letter X: to represent an item number - as in the toggle switch, rotary switch, and load symbols - or to represent a digit of a variable parameter. For example, the XX in XXOC would be the value of the variable temperature parameter being displayed. The nature of the use of any X in a display is implied by the context in which it appears. The exact parameter to which it corresponds can be easily determined from the corresponding page in the expanded matrix.

The only hardware switches that must be considered in the construction of this set of schematic displays for the CDMS are the hardware switches on the DDU's and KB's. This relatively small number of hardware switches,

together with the very high degree of similarity between the DDU/KB symbols and the actual appearance of the real DDU/KB's, greatly simplifies the often difficult task of attaining a high level of CRT display-hardware control compatibility. However, provisions must still be made for the capability to code onto the displays the difference between a software control and a hardware control. The simple code that was chosen requires only two straight lines for each control - a vertical straight line on both sides of the control symbol. This code is meant to simulate the appearance of the guard rails that are often used to protect hardware controls from being inadvertently repositioned.

The set of theoretical displays exhibits many of the characteristics theoretically desirable in a set of schematic displays for providing information related to a subsystem. However, there are several problems that would make these theoretical displays impractical to implement and somewhat inefficient to use.

Because there is a one-to-one correspondence between the pages in the expanded matrix and the theoretical display, there is the possibility of having to generate up to $(N^2 + N)/2$ theoretical displays, where N is the number of rows and columns in the matrix. Even if the matrix is quite sparse, there can be a large number of theoretical displays. Even with a very low software overhead for each display, the large number of displays would create a significant total software overhead.

Another problem is that the information coded into each theoretical display is completely determined by the information contained in the corresponding page of the matrix. Some displays end up containing a small amount of information. For example, the only information obtainable from display (14,22) is that the HRM and PLRC are directly linked by a data bus. On the other hand, some displays present a fairly significant amount of information. For example, display (12,12) provides complete status information relating to all three DDU's. If a display contains an appropriate amount of information, it is only a coincidence.

A third problem is that the theoretical displays might not necessarily contain information in an organization that is optimum for the tasks to be performed with use of the displays. For example, a user attempting to determine the overall temperature status of the CDMS would have to sequence through a large number of displays and look only for the temperature symbols. The designer of the theoretical displays has no control over this display/task incompatibility, because the information that must be coded onto each display is taken directly from the matrix. In addition, at this point in the analysis of the subsystem, the actual tasks that must be performed with use of the final, practical displays have not yet been considered.

The problem to be confronted now is how to combine the theoretical displays to form practical displays such that the total number of displays is reduced, there is an appropriate amount of information on each display, and the information on the displays and the displays themselves are organized to provide the maximum level of display/task compatibility possible.

The Practical Displays

The objective now to be attained is development of a scheme for combining the theoretical displays to form practical displays. The major factors in determining this scheme are the specific tasks for which the displays are to be used. The choosing of appropriate combinations of theoretical displays is, essentially, the selection of a cross section of the subsystem best illustrating the aspects of that subsystem to be dealt with in performing the tasks for which the displays are to be used. As with the construction of the matrix, there are no set rules determining what the scheme should be or even how to determine what the scheme should be for combining the theoretical displays. The nature of the scheme will depend mostly on the nature of the tasks to be performed with use of the displays. Once a scheme has been developed to cross section the subsystem for a specific task, such as activation or deactivation of the subsystem, it should be held to as a standard for the design of the displays that will be used for performing that task.

For the CDMS, three tasks that the schematic displays would be used for were defined: activation of the CDMS, monitoring and controlling of the CDMS, and deactivation of the CDMS. A special problem is presented by this situation because there are several opposing factors that must be considered. Theoretically, two separate tasks could be sufficiently different to necessitate separate sets of displays, derived by taking completely different cross sections of the subsystem. It would be highly desirable to have two separate sets of displays, one for each task. However, the software cost involved would be much too high to balance the advantages, unless it was absolutely necessary to have separate sets of displays. A solution to this problem was found in the use of variable tutorials. Because the cross section of the subsystem is essentially the same for activation, monitoring and controlling, and deactivation, although the use of the displays would be different for each task, it is possible to provide a set of basic schematic displays and use three sets of tutorial messages to alter the displays so that they conform to the specific task that must be performed. The software cost involved is not very high; but before the reason for this can be understood, it is necessary to discuss the special programming techniques that must be used to efficiently implement the schematic displays.

In general, the geometric and spatial coding used in schematic displays greatly reduces the amount of information that can be presented on the CRT screen at one time. It is unlikely that all the information related to a subsystem that would be necessary to perform the required tasks could be coded onto one display. Use of conventional MCDS programming techniques would make page flipping impractical. Although not high, the software overhead for each new display is significant. It is important to realize that the CDMS displays would be used only on orbit, would be generated by a simplex-running GPC dedicated to system management and payload functions, and would not have to be GPC main memory or display electronics unit (DEU) memory resident. Any display required that was not already in the appropriate GPC main memory could be rolled in from the Orbiter mass memory. However, a minimum response time of approximately 4 seconds for rolling in a new display exceeds the maximum response time required for reasonably smooth page-flipping operations.

This problem can be overcome by using a programming technique that would allow a number of displays to appear to the GPC's cyclic processor as a single display. This concept is illustrated in figure 8. There is no restriction on the overwriting of data onto the CRT screen. Therefore, it is possible to code a single display so that more than one section of code will cause figures to be generated on the same region of the CRT screen. Each section could actually be the code for a separate schematic display. An item number would be entered on the MCDS keyboard to switch execution to another section of the code for the one real display and, in doing so, effectively switch schematic displays. At the beginning of each section of code, each of which is the code for generating a schematic display, a test for an item number status would be made. If the test indicated that the item number had not been executed, the GPC's cyclic processor would branch around the entire section of code and would execute the test for item number execution corresponding to the next section of code. If the test corresponding to an item number indicates that it has been executed, then that section of code would be processed and the corresponding schematic display would be generated. Of course, only one section of code for a real display should ever be processed at one time, because if more than one section of code were processed in the same cycle, then overlapping schematic displays would appear on the CRT screen. Therefore, when a schematic display is no longer needed and a new schematic display is called up, the item number associated with the old schematic display must be reset by the software to indicate that it currently has a "not executed" status. Because the GPC's cyclic processor runs at 2 Hz, it is possible to achieve a fairly fast response time for switching schematic displays and the concept of page flipping becomes feasible. Of course, the number of schematic displays that could be contained in one real display would depend on the amount of code associated with each schematic display and the amount of GPC memory available in which to store a real display that has been rolled in from mass memory. However, it is expected that the code for all the schematic displays that would be associated with a subsystem could be contained in a single real display. The one rigid restriction is that the amount of code (associated with one schematic display) sent from the GPC to the DEU cannot exceed the size of the DEU buffer, which is 1627 half words. However, this is a fairly large capacity and it is very unlikely that any one schematic display would even come close to this limit. If a schematic display was needed that was not contained in the current real display, the appropriate real display could be rolled in by using the SPEC key, but the response time would be over 4 seconds. However, the grouping of the schematic displays can be strategically organized to minimize the likelihood of this occurrence at a point that would significantly disrupt a crewmember's concentration on a problem.

Because the code for a number of schematic displays would be contained within a group of code that the cyclic processor considers to be one real display, there would be only one item-number table for all the schematic displays grouped together. Therefore, although the item numbers on a schematic display would be consecutive, they would not necessarily begin with item number 1. Some item numbers would be used to switch schematic displays; other item numbers would be used to execute commands and enter data associated with the schematic displays. There could also be three dedicated item numbers, possibly 1, 2, and 3, for each real display: one for calling up the activation tutorial messages, one for the monitoring and controlling tutorials, and

the third for deactivation tutorials. The code for generating the tutorial messages would have to be grouped according to type, activation, monitoring and controlling, and deactivation; and according to the specific schematic displays. Therefore, there is an overhead associated with the tutorial messages, regardless of how many messages there are. However, as will be discussed later, in the section on costs, it is very probable that no tutorial messages would be incorporated into the final, flight version of the schematic displays.

The scheme that was used for combining the theoretical CDMS schematic displays to form practical displays compatible with the performance of CDMS activation, monitoring and controlling, and deactivation sequences was to examine flow charts of the sequences and combine the theoretical displays containing the information required to perform the sequences. Because similar information is usually required for activation, monitoring and controlling, and deactivation, it was possible, at least for these CDMS schematic displays, to combine the information required for all three tasks so that only one set of schematic displays was necessary. This set of schematic displays and the flow charts of the activation, monitoring and controlling, and deactivation sequences are presented in figures 9 through 69. The displays are not presented in the order in which they would necessarily be used. In addition, the displays sometimes provide an indication of an action external to the CDMS, one which would be performed with the use of controls other than those available for use in this set of schematic displays. The geometric codes for these indicators will be discussed as each of the codes is introduced.

Figure 9 illustrates an index display that could be used in conjunction with this set of schematic displays. The geometric and spatial coding for the units of the CDMS is identical to the coding used in the overall schematic diagram. The X associated with each unit represents an item number that would be executed to call up the display that provides more detailed information related to that unit. In the event that accessing a specific schematic display would require rolling in a new real display, the X associated with that schematic display would represent the number of the real display in which it is contained, instead of an item number. Item numbers are easily distinguishable from display numbers because item numbers are either one or two digits and display numbers are three digits. If all the schematic displays for a particular subsystem cannot be contained in a single real display, there should be a copy of the index display available in each real display, of course displaying appropriate item numbers and display numbers for the schematic displays contained in that real display. Hence, quick access to the index display would be provided regardless of which real display is in the GPC buffer. In addition to the item number associated with every schematic display, including the index display, it might be advisable to implement the real displays so that when they are called up, the index display initially appears. This would provide information enabling crewmembers to call up the specific schematic displays required, yet always be able to quickly and easily refer to the index display by executing the item number associated with it.

The upper right corner of the display indicates that there are three special item numbers: one for calling up the activation tutorials, one for the monitoring and controlling tutorials, and one for the deactivation tutorials. These item numbers would probably be 1, 2, and 3. Execution of one of these item numbers would result in the display of the appropriate tutorials in all the schematic displays contained in the real display, of which the index display is a part. Therefore, a crewmember could sequence through a set of schematic displays without having to call up the tutorials for each individual schematic display. However, if a crewmember was using a specific schematic display and wanted to change the tutorials for that display, the new set of tutorial messages could be called up just by executing the appropriate item number; it would not be necessary to return to the index display.

It is also possible for the index display to provide ON/OFF and GO/NOGO information related to the units of the CDMS. The standard dashed-line-for-off and solid-line-for-on code can be used for the symbols of the units. If the expanded matrix indicates that there is a measurement providing GO/NOGO information related to a specific unit, then, to indicate a NOGO condition, the symbol for that unit could be displayed either overbright or flashing.

Figures 10, 12, and 14 are the flow charts for the SS COMP activation, monitoring and controlling, and deactivation, respectively. To accomplish the task indicated by each symbol on the flow charts, the appropriate entries in the expanded matrix must be referenced. For example, figure 10 contains a symbol indicating that the SS COMP temperature should be checked to see if it is in limits. Pages (45,45) and (46,46) of the expanded matrix contain measurements that provide temperature data on the SS COMP CPU and memory, respectively. In addition, page (2,2) of the expanded matrix indicates that there is a measurement that provides a GO/NOGO indication for the SS COMP internal temperature. To incorporate these three different measurements from three different pages in the expanded matrix into a practical display, it is necessary to combine the representation of these three measurements from the three corresponding theoretical displays. The result is the TEMP section in the upper left area of the SS COMP, as is illustrated in figure 11(a). Notice that the temperature symbol, which was described in figure 7(d), is used in both of its two possible ways, as a GO/NOGO indicator for the SS COMP internal temperature and as a visual cue to the location of the temperature values for the SS COMP CPU and memory.

Similarly, the other symbols appearing within the symbol of the SS COMP in figure 11(a) are designed by combining symbols from the appropriate theoretical displays.

External to the SS COMP symbol are five indicators corresponding to the first five instructions stated in the flow chart of figure 10. These instructions indicate that verification of certain units being on should be obtained. The five corresponding symbols on the display would be driven dashed if they were off and solid if they were on. In addition, although it is not explicitly stated in the flow chart, if a failed indicator measurement exists for a particular unit, it would be possible to drive its symbol overbright or flashing in the event of a failed condition. The geometric and spatial coding of the overall schematic diagram is still maintained in the practical displays.

That is, the SS COMP, SSIO, MMU, and RAAB symbols are the standard symbols for these units, and they also appear in the same positions relative to each other as in the overall schematic diagram and the theoretical displays. However, as mentioned before, there is not enough space on the CRT screen to incorporate any size coding in the symbols representing the units of the subsystems. The size of a symbol is determined by the amount of information that must be displayed within the symbol and the amount of space on the display that is available for the symbol.

The first two instructions of the flow chart specify that information must be obtained related to aspects external to the CDMS. Additional symbols must be designed to incorporate this information into the displays. The CDMS DC1 symbol utilizes the standard electrical symbol described in figure 7(c). The water-cooling symbol is meant to abstract a pipe carrying water to the SS COMP. It is interesting to note that the geometric coding for this symbol has a very low software cost, only two straight lines. These CDMS DC and WATER symbols are standard for all the practical displays in which they are used.

Consider the activation tutorials presented in figure 11(a). The circled numbers reflect the order of task execution implied by the flow chart. Tutorials 1 through 5 have a single solid line as a message. The line indicates that the appropriate unit should be checked to see that it is in an ON condition. This would mean that its symbol should be displayed solid. Tutorials 6 and 8 indicate that a check must be made to see that AUTOSTRT is OFF. If AUTOSTRT is ON, then activation of the SS COMP should be abandoned and the BU COMP should be activated. Tutorials 7, 9, and 10 appear next to indicators having item numbers associated with them. Therefore, when these steps in the activation sequence are reached, the appropriate item numbers should be executed. Tutorial 11 indicates that the temperature limits should be checked and that if they are exceeded, the BU COMP should be activated. Tutorial 12 requests that the SS COMP be checked for a failed condition. Because the practical displays are not necessarily designed independently of each other and because, for example, it is recognized that the SSIO can be interfaced to either the SS COMP or the BU COMP, the use of more than one practical display is required for several of the sequences specified by the flow charts. As the flow chart of figure 10 progresses to deal with aspects of the SSIO links, tutorial 13 in figure 11(a) indicates that a different display should be called up. This would be accomplished by executing the specified item number. This, of course, implies that the practical displays of figures 11(a) and 11(b) would have to be generated by just different sections of code of the same real display in the GPC buffer. Although it would be possible to have a tutorial indicating the callup of a new real display, a great attempt should be made to avoid forcing a crewmember to do this during a sequence, because the minimum response time of 4 seconds for calling up a new real display far exceeds the tolerable limit for response times in a page-flipping environment. Because mental closure will most likely occur at the end of an activation, monitoring and controlling, or deactivation sequence for a particular unit of the subsystem, new real displays should be required to be called up at the end of sequences, not during them.

Figure 11(b) illustrates the second display that would be used in the SS COMP activation sequence. Tutorial message 4 indicates that the SSIO should be checked for any coupler failures. If a failure occurred, the appropriate coupler symbol would be driven overbright or flashing. There are two tutorial messages labeled 5 because, as figure 59(b) indicates, this display could also be used in the BU COMP activation sequence. If it is used in the SS COMP activation sequence, the SS COMP symbol is checked to make sure that it is ON. If it is used in the BU COMP activation sequence, the BU COMP symbol is checked to make sure that it is ON.

Figures 12, 13(a), and 13(b) illustrate the flow chart and corresponding displays for the SS COMP monitoring and controlling sequence. The basic displays are identical to those used for the activation sequence. Only the tutorial messages are different. The monitoring and controlling tutorials would be called up by executing the item number associated with them. Tutorial messages 7, 8, and 9, being just circled numbers located next to the label codes for their respective symbols, imply that the symbols should be checked for whatever type of information they present. These types of tutorial messages, being only circled numbers, are only used when the type of information that the symbols are presenting is very obvious. For example, tutorial 9 refers to the SPWR GO,NOGO indicator. Because the indicator is only the electrical symbol, it is obvious that it is a GO,NOGO indicator and has only to be checked that it is displayed solid and is not being driven overbright or flashing. Figures 14 and 15 present the SS COMP deactivation sequence, which is very simple and consists only of turning the SS COMP power OFF.

The similarity between the information required to perform the SS COMP activation, monitoring and controlling, and deactivation sequences makes it possible to use the same base displays for each sequence and vary only the tutorial messages between the sequences. The information required to perform the SS COMP activation, monitoring and controlling, and deactivation sequences, which is the information required to be incorporated into the base displays for the SS COMP, is obtained from theoretical displays (2,2), (2,4), (4,6), (6,6), (7,7), (8,9), (8,10), (9,10), (9,27), (10,27), (11,11), (11,19), (11,29), (18,26), (24,24), (25,25), (26,26), (27,27), (28,28), (29,29), (30,30), (30,45), (30,47), (45,45), and (46,46). The combination of the required information from these theoretical displays to form the two practical SS COMP base displays is, essentially, the taking of the part of the activation, monitoring and controlling, and deactivation cross sections of the CDMS that deals with the activation, monitoring and controlling, and deactivation of the SS COMP. All the practical displays presented in this section, when considered, as they should, to be a single, related set of schematic displays, represent the activation, monitoring and controlling, and deactivation cross sections of the entire CDMS, at least from the point of view of interfacing to the CDMS through the Orbiter MCDS.

Figures 16 through 21 present the flow charts and corresponding displays for the SSIO activation, monitoring and controlling, and deactivation sequences. Tutorial messages 4, 5, and 6 of figure 17 indicate that an attempt should first be made to turn on all the SSIO A couplers. If an A coupler does not come on, the corresponding B coupler should be turned on. Whereas an attempt should be made to deviate as little as possible from the theoretical displays when the

practical displays are being designed, there are some instances wherein deviations are necessary. The switch to turn the SSIO B couplers on illustrates a tolerable concession that must be made to fit the required SSIO parameters onto one display. Aspects from theoretical displays (23,23), (24,24), (25,25), (26,26), (27,27), and (28,28) are combined to form the section of the practical display used to turn the SSIO B couplers on. In each of these theoretical displays, there is a separate software switch for turning the corresponding B coupler on. Therefore, the practical display really should also contain a separate switch for each B coupler; however, this would require much more space than is available. Instead of separate switches, a single switch with radial lines leading to the appropriate item numbers and couplers is used.

Figures 22 through 27 present the flow charts and practical displays associated with the activation, monitoring and controlling, and deactivation of the HRDR. The HRDR displays are the only practical displays making use of the software rotary switch. These displays also make a small concession to available space on the CRT screen. Notice that the small MMU symbol appears to the right of the upper section of the large HRDR symbol instead of directly above the HRDR symbol as it does in the overall schematic diagram.

Figures 28 through 33 present the flow charts and practical displays for the MMU. An important point to notice is that although the CDMS DC symbols and WATER symbols do not appear on the overall schematic diagram or in the theoretical displays, when they are incorporated into the practical displays, an attempt is made to attain some standardization to their locations on the displays. In these practical displays for the CDMS, whenever possible, the CDMS DC symbol and the WATER symbol are always located on the right of the symbol to which they are linked, and the CDMS DC symbol always appears directly above the WATER symbol.

Figures 34 through 39 present the flow charts and practical displays for the DDU's and KB's. Because only these practical displays contain a display of hardware switches, they are the only practical displays in which there is an opportunity to illustrate the high degree of CRT display-hardware control compatibility attainable with the use of schematic CRT displays. As in theoretical displays (12,12) and (13,13), the symbols representing the hardware controls appear in approximately the same locations on the large DDU and KB symbols as on the real DDU's and KB's, and are made to resemble the real hardware controls in appearance as much as possible.

Consider the activation sequence for the DDU's and KB's. Tutorial messages 1 through 4 on figure 35 are similar to those previously discussed. Tutorials 5 and 6 correspond to the only occurrence of the data entry item number option in this set of practical displays. As indicated in the master command and measurement list presented in tables 1 and 2, there exists the possibility of nine different DDU/KB combinations, because any of the three DDU's can be linked to any of the three KB's. This is reflected by the entries in page (12,13) of the expanded matrix. To avoid having the nine separate DDU/KB symbols of theoretical display (12,13), the data entry item numbers are used. To obtain information related to any of the DDU's and KB's, the number of the appropriate DDU and KB are entered. The DDU and KB to which the display corresponds do not even necessarily have to be linked

to each other, although, at least for performing the activation sequence, they almost certainly would be. In the event that information is needed about only a DDU or only a KB, then it would only be necessary to enter the appropriate DDU or KB number; the section of the display corresponding to the other unit, DDU or KB, would not provide any information. After selection of the DDU and KB to be activated, the KB power is turned on by using a hardware switch on the KB. The KB power is checked and then, by use of another hardware switch on the KB, the KB is linked to the SSIO. When the SS/EXP switch is moved; the digital counter labeled "WAIT" and associated with tutorial message 12 begins to count down from 45 seconds. When the count reaches zero, the activation sequence can be continued. The DDU power is turned on by using a hardware switch on the DDU. The DDU power is checked, after which the hardware display duration rotary switch, labeled "DISDUR" on the display and associated with tutorial 5, is turned to its maximum level, 5. Tutorial 18 then indicates that the hardware RSET/TEST switch on the DDU should be moved to the TEST position. The test picture should appear on the CRT screen, and tutorial 19 indicates that the real DDU screen should be viewed to check the test picture. As tutorial 20 indicates, the hardware brightness rotary switch on the DDU should then be used to adjust the brightness of the test picture. The RSET/TEST switch is then moved to the RSET position and, as tutorial 22 indicates, the CDMS management display should appear on the real DDU screen.

Figure 40 through 45 present the flow charts and practical displays for the SS RAU's activation, monitoring and controlling, and deactivation sequences. As in the SSIO practical displays, a concession is made with respect to available space on the CRT screen; and unlike theoretical display (32,32), which has a separate software switch to turn each SS RAU on, a single switch symbol is used with radial lines pointing to the appropriate item numbers.

Figures 46 through 51 present the flow charts and practical displays for the EXP COMP. They are very similar to those for the SS COMP and do not introduce any different concepts.

Figures 52 through 57 present the flow charts and practical displays for the EXP IO. They are very similar to those for the SSIO and do not introduce any different concepts.

Figures 58 through 63 present the flow charts and practical displays for the BU COMP. The activation sequence flow chart of figure 58 illustrates the difference between the procedures that must be performed depending on whether the BU COMP is taking over the SS COMP's tasks or the EXP COMP's tasks. This is further reflected in figures 59(a), (b), and (c). In figure 59(a), tutorial messages 1, 2, and 13 are duplicated. Execution of the item number associated with the left-hand tutorial message 13, to be used when the BU COMP is taking over the SS COMP's tasks, would result in the display presented in figure 59(b) being called up; execution of the item number associated with the right-hand tutorial message 13, to be used when the BU COMP is taking over the EXP COMP's tasks, would result in the display presented in figure 59(c) being called up. As discussed earlier, the displays presented in figures 59(b) and 61(b) would also be used in performing the SS COMP activation and monitoring

and controlling sequences, respectively, and the displays presented in figures 59(c) and 61(c) would also be used in performing the EXP COMP activation and monitoring and controlling sequences, respectively.

Figures 64 through 69 present the flow charts and practical displays associated with the RAAB activation, monitoring and controlling, and deactivation sequences.

Now that the set of practical schematic displays that can be used for providing information related to the CDMS has been described, it is necessary to discuss the software costs that would be associated with implementing schematic displays similar to those just presented.

COSTS

When a crewmember first encounters the set of displays to be used to perform a task associated with a particular subsystem, it will be possible to provide displays similar to the practical displays presented in the last section, containing an extensive amount of labeling and a large number of tutorial messages. However, these factors present an unusual problem. The MCDS CRT screens are quite small, yet even the small alphanumeric characters are large in relation to the screen. The characters are relatively large because they must be easily readable during ascent and entry phases, at which time crewmembers will be strapped into their couches. However, during the on-orbit phase, which is when these schematic displays would be used, and especially during operations from the aft flight deck, these restrictions do not exist. Without any clutter being produced, much denser schematic displays with much smaller symbols and characters for labeling and tutorials would be perfectly acceptable and actually quite desirable in that it is easier for an operator to look at another region of the same display than to call up a new display when additional information is required. The problem presented is that the relatively large size of the characters that must be used for labeling and tutorials greatly limits the size of the geometric symbols used. However, it probably would not take very long for a crewmember to learn all the geometric and spatial coding used in the displays well enough that the labels would not be needed, and become familiar enough with the procedures that the tutorials would not be needed. Actually, in later phases of training, when a crewmember is very familiar with a set of displays, the labels and tutorials might even be considered clutter. Removing most of the characters from the displays solves the problem of not being able to use small symbols and, therefore denser displays. There could always be a hard-copy page or even a separate CRT display that would indicate what each symbol represents, in the event that a crewmember might not remember exactly what a symbol means.

The software cost associated with programming in the labels and tutorial messages that would be incorporated into the schematic displays to be used for initial training is not really important, because the functional simulators do not even use flight software. For the flight software, the use of denser schematic displays containing few labels and no tutorial messages would not only provide a very efficient man/machine interface from a human factors point

of view, but, as will be discussed, would also result in a reduction of the software costs associated with providing crewmembers with subsystems information.

Memory Costs

To determine how much less the memory costs would be for schematic displays than for tabular displays, the simple but representative MMU schematic displays presented in figures 29, 31, and 33 were used as a base for a comparison analysis. Table 3 indicates the costs for the features of the displays used in the analysis. It is important to notice that because each real display that can be rolled into the CPU's buffer actually consists of the code for a number of schematic displays, all the features of the schematic displays exist in a dynamic environment rather than as background features. The costs presented in table 3 were also used for the tabular display designed for the analysis, although not all the features of a tabular display would necessarily have to exist in a dynamic environment.

Figures 70(a), (b), and (c) illustrate the schematic display with labels and tutorials and are essentially equivalent to figures 29, 31, and 33, respectively. However, they are not drawn on the standard Orbiter MCDS template because, unlike displays 29, 31, and 33, there should be no implication that the MMU display used in the comparison analysis is necessarily a separate and complete schematic display. It may only be part of a more comprehensive schematic display. The analysis is not affected, regardless of whether it would be a separate and complete schematic display or a part of a more comprehensive schematic display. Figures 70(a) and (c) contain a tutorial message slightly different from the corresponding message in figures 29 and 33. For the PWR ON tutorial, number 4, of the activation display, instead of just placing a circled 4 next to the item number that would turn the power on, the circled 4 is placed next to the up-arrow PWR ON indicator of the software switch, and a tutorial up-arrow is added next to the location in which the indicator up-arrow would appear. The same type of tutorial arrow is also used for the PWR OFF tutorial, number 1, of the deactivation display. Because only the up- or the down-arrow indicator would be displayed, depending on whether the power was on or off, respectively, it would be a very simple visual check to see that the condition of the MMU PWR corresponds to the required condition indicated in the sequence being executed. The one indicator arrow being displayed and the one tutorial arrow being displayed must match; either they both must be up-arrows or both down-arrows. Table 4 presents the costs for each of the individual features of the schematic display with labels and tutorials. Because execution of the item number that calls up the activation tutorials, monitoring and controlling tutorials, or deactivation tutorials results in those tutorials being called up for all the schematic displays contained in the real display currently in the GPC buffer, the cost of these three item numbers and the tests associated with them would be considered for the entire real display and then averaged out among all the schematic displays contained in that real display to determine how much cost for switching tutorials should be assessed to each schematic display. The total cost indicated in table 4 does not include the cost for switching tutorials. In table 4, the character-pairs feature indicates the number and cost of the individual character pairs

in the display. For example, TEMP consists of two character pairs, TE and MP. The character-strings feature is just the number of separate character strings in the display. Because the characters exist in a dynamic environment, there is an overhead cost of 1 half word (hw) for each character string. To display the indicator arrows of the software power (PWR) switch, the remote text command (RTC) can be used. The cost would be 4 hw for positioning and 3 hw for the RTC. To display the arrows of the tutorial messages, either the RTC could be used or, because a test has already been made to see if the arrow should be displayed or not, the arrow could just be displayed as a special character costing 4 hw for positioning, 2 hw for a special character, and 1 hw for a character string in a dynamic environment. Regardless of which technique is used, the cost for the tutorial arrows is 7 hw each. The test feature indicated in table 4 corresponds to the test to determine whether the MMU, CDMS DC2, WATER, and RAAB symbols should be displayed solid or dashed. The cost for each of these tests is 9 hw, 3 hw for the TEST command, 3 hw for the DASH ON command, and 3 hw for the DASH OFF command. Figure 71 illustrates the test for whether a symbol should be displayed solid or dashed.

As mentioned earlier, when a crewmember is very familiar with a set of schematic displays and with the tasks to be performed with use of the displays, extensive labeling and tutorial messages might even be considered clutter. Therefore, it would probably be advantageous if the schematic displays actually implemented into the flight software contain no tutorials and a minimum amount of labeling. Such changes would also make it possible to draw smaller symbols and fit more information onto the CRT screen at one time, because the size of the characters can easily be the limiting factor in how small a symbol can be drawn. Figure 72 illustrates the MMU schematic display without labels and tutorials. It probably would not be a separate and complete schematic display as it is, but part of a more comprehensive schematic display involving other units of the CDMS in addition to the MMU. In the event that a crewmember might not remember exactly what a symbol means, there could always be a hard-copy page or even a separate CRT display indicating what each symbol represents. In addition, there is a tremendous decrease in the amount of memory required for schematic displays with no labels and tutorials. Table 5 indicates that the total cost for the MMU schematic display without labels and tutorials is only 219 hw.

To complete the comparison analysis, an MMU tabular display exactly equivalent in information content to the display presented in figure 72 was designed. The MMU tabular display is illustrated in figure 73. In the top half of the display, to turn the power on, the item number to the left of ON would be executed and the asterisk to the right of ON would be displayed. A similar procedure would be executed to turn the power off. The bottom half of the MMU tabular display provides status information relating to aspects external to the MMU, the CDMS DC2, WATER, and the RAAB. The appropriate asterisk in either the ON or the OFF column would be displayed for each aspect. Table 6 indicates what the costs for the features of the MMU tabular display would be. The feature "Tests and indicators" refers to the eight asterisks in the display. The total cost for the MMU tabular display is 258 hw, 39 hw more than the cost of the MMU schematic display without labels and tutorials. For these MMU displays, the memory cost of the schematic display

without labels and tutorials is 15.1 percent less than the memory cost of the tabular display. This, of course, does not imply that schematic displays would all cost exactly 15.1 percent less than the equivalent tabular displays. In some instances, the cost decrease for schematic displays may be more than 15.1 percent; and in others, it may be less than 15.1 percent. However, there exists a definite potential for designing schematic displays that would have a memory cost significantly less than the cost of the equivalent tabular displays.

Time Costs

Figure 8, referred to in the section on practical displays, illustrates how it is possible to code more than one schematic display into a real display so that more than one schematic display can reside in the GPC buffer at one time. In addition to providing a response time of approximately 1/2 second for switching schematic displays, which makes page flipping practical; this technique can also save a considerable amount of the CPU time required for processing the code associated with the displays. Because the cyclic processor would only execute the code associated with generating the FCW's required to display one schematic display - branching past all the code for the other schematic displays in the GPC buffer - and because the amount of code corresponding to a schematic display that provides information relating to an aspect of a subsystem would be far less than the amount of code corresponding to a dense, comprehensive, tabular display that provides information relating to that entire subsystem, there would be far less CPU time required for displaying the schematic display than for displaying the tabular display. Of course, this technique could also be used for tabular displays; however, as discussed in the appendix, the basic nature of tabular displays makes it extremely difficult to design them so that a high level of memory retention can be obtained for the information presented on the displays. Hence, the technique of using page flipping with less dense tabular displays would be somewhat impractical. The pictorial nature of schematic displays makes it possible to design them so that a very high level of memory retention can be obtained for the information presented on the displays; hence, the technique of using page flipping with displays that are not too dense would be very practical. A second possibility would be to update only one section of a tabular display at one time, or at least at a high update rate. The other sections would remain static or could be updated at a slow rate. A crewmember would execute an item number to switch the high update rate to a different section of the display. It would even be possible to provide the crewmember with the capability of assigning any update rate, from those available, to each of the sections of the display. However, a single display on which similar types of parameters have different update rates could be very disconcerting. In addition, and much more importantly, displaying dynamic parameters statically can be very misleading. Therefore, although there are techniques available that would reduce the amount of CPU time required for processing the code associated with tabular displays, it is advisable that they not be used.

The technique described for coding schematic displays that could be used in a page-flipping environment would also result in a considerable decrease in the amount of CPU time required for processing the code associated with the displays.

CONCLUSION

In this document, the concept of designing schematic displays for the Space Shuttle Orbiter multifunction CRT display system was explored. With use of the Spacelab CDMS as an example, the technique of indexing the units of a subsystem, and all the relationships existing between them, into a matrix was illustrated. The information in the matrix can be used to establish an overall schematic diagram of the subsystem. From the overall schematic diagram, a set of theoretical displays that schematically presents all the information in the matrix of relationships can be designed. In what essentially is the taking of a cross section of the subsystem to provide the required information in an organization that will provide a very high level of compatibility between the information presented on the displays and the tasks to be performed with use of the displays, the theoretical displays can be combined to form practical displays. A cost analysis indicated that the memory cost of schematic displays can be significantly less than the memory cost of the equivalent tabular displays. A technique for coding schematic displays was described that would result in a considerable decrease in the amount of central-processing-unit time required for processing the code associated with the displays. Investigations and experiments supporting the concept of schematic displays for the MCDS and guidelines to be followed in designing schematic displays are discussed in two appendixes.

The information presented in this document indicates that consideration should definitely be given to the use of schematic displays for the Space Shuttle Orbiter multifunction CRT display system.

Lyndon B. Johnson Space Center
National Aeronautics and Space Administration
Houston, Texas, March 17, 1978
953-36-00-00-72

TABLE 1.- SPACELAB MASTER COMMAND FUNCTION LIST
 (Subsystem S03: control and data management subsystem)

Command ID no.	Command name	Source			
		SM 3P	LM	5P	3P
S03K0001Y	CDMS Master PWR Off	NR	NR	NR	NR
S03K0101Y	SS-COMP PWR On/SS DMA to SS-COMP	MR	MR	MR	MR
S03K0102Y	SS-COMP PWR Off/AUTO RESTART Off	MR	MR	MR	MR
S03K0105Y	SS-COMP AUTO RESTART On	M	M	M	M
S03K0106Y	SS-COMP Reload Via MMU	MR	MR	MR	MR
S03K0107Y	SS-COMP Reload Via MDM	MR	MR	MR	MR
S03K0131Y	BU-COMP PWR On/SS DMA to BU-COMP	NR	NR	NR	NR
S03K0132Y	BU-COMP PWR Off/AUTO RESTART Off	MR	MR	MR	MR
S03K0133X	BU-COMP PWR On/EXP DMA to BU-COMP	CR	CR	BR	BR
S03K0135X	BU-COMP AUTO RESTART On	C	C	B	B
S03K0135Y	BU-COMP AUTO RESTART On	N	N	N	N
S03K0136X	BU-COMP Reload Via MMU	CR	CR	BR	BR
S03K0136Y	BU-COMP Reload Via MMU	NR	NR	NR	NR
S03K0137X	BU-COMP Reload Via MDM	CR	CR	BR	BR
S03K0137Y	BU-COMP Reload Via MDM	NR	NR	NR	NR
S03K0161X	EXP-COMP PWR On/EXP DMA to EXP-COMP	DR	DR	CR	CR
S03K0162X	EXP-COMP PWR Off/AUTO RESTART Off	DR	DR	CR	CR
S03K0165X	EXP-COMP AUTO RESTART On	D	D	C	C
S03K0166X	EXP-COMP Reload Via MMU	DR	DR	CR	CR

Nine possible additional commands might be
 K_i to DDU_j
 where
 i = 1, 2, 3
 j = 1, 2, 3

TABLE 1.- Continued

Command ID no.	Command name	Source			
		SM 3P	LM	5P	3P
S03K0167X	EXP-COMP Reload Via MDM	DR	DR	CR	CR
S03K0191X	MMU PWR On	CR	CR	BR	BR
S03K0191Y	MMU PWR On	MR	MR	MR	MR
S03K0192X	MMU PWR Off	CR	CR	BR	BR
S03K0192Y	MMU PWR Off	MR	MR	MR	MR
S03K0201Y	I/O-SS PWR A On/DMA to SS-COMP	MR	MR	MR	MR
S03K0202Y	I/O-SS PWR B On	NR	NR	NR	NR
S03K0203Y	I/O-SS PWR A+B Off	MR	MR	MR	MR
S03K0204Y	I/O-SS All Req. Couplers A On	MR	MR	MR	MR
S03K0211Y	I/O-SS MDM Coupler B On	NR	NR	NR	NR
S03K0212Y	I/O-SS PCMMU Coupler B On	NR	NR	NR	NR
S03K0213Y	I/O-SS MMU Coupler B On	NR	NR	NR	NR
S03K0214Y	I/O-SS RAU Coupler B On	NR	NR	NR	NR
S03K0215Y	I/O-SS DDU/KBD Coupler B On	NR	NR	NR	NR
S03K0216Y	I/O-SS Time Coupler Off	MR	MR	MR	MR
S03K0251X	I/O-EXP PWR A On/DMA to EXP-COMP	DR	DR	CR	CR
S03K0253X	I/O-EXP PWR A+B Off	DR	DR	CR	CR
S03K0254X	I/O-EXP All Req. Couplers A On	DR	DR	CR	CR
S03K0261X	I/O-EXP MDM Coupler B On	CR	CR	BR	BR

Two possible additional commands might be

I/O - SS HRM Coupler B on (Y, NR, NR, NR, NR)
I/O - EXP HRM Coupler B on (X, CR, CR, BR, BR)

TABLE 1.- Continued

Command ID no.	Command name	Source			
		SM 3P	LM	5P	3P
S03K0262X	I/O-EXP PCMMU Coupler B On	CR	CR	BR	BR
S03K0263X	I/O-EXP MMU Coupler B On	CR	CR	BR	BR
S03K0264X	I/O-EXP RAU Coupler B On	CR	CR	BR	BR
S03K0265X	I/O-EXP DDU/KBD Coupler B On	CR	CR	BR	BR
S03K0252X	I/O-EXP PWR B On	CR	CR	BR	BR
S03K0266X	I/O-EXP Time-Coupler Off	DR	DR	CR	CR
S03K0301Y	All RAU-SS On	MR	MR	MR	MR
S03K0302Y	All RAU-SS Off	MR	MR	MR	MR
S03K0311Y	RAU-SS A On	NR	NR	NR	NR
S03K0316Y	RAU-SS B On	NR	NR	NR	NR
S03K0321Y	RAU-SS C On	NR	NR	NR	NR
S03K0326Y	RAU-SS D On	NR	NR	NR	NR
S03K0331Y	RAU-SS E On	NR	NR	NR	NR
S03K0336Y	RAU-SS F On	NR	NR	NR	NR
S03K0341Y	RAU-SS G On	NR	-	NR	-
S03K0346Y	RAU-SS H On	NR	-	NR	-
S03K0401X	All RAU-EXP On	DR	DR	CR	CR
S03K0406X	RAU-EXP Top Airlock On	-	D	-	-
S03K0407X	RAU-EXP Top Airlock Off	-	D	-	-
S03K0411X	RAU-EXP Rack 2 On	E	E	-	-
S03K0412X	RAU-EXP Rack 2 Off	E	E	-	-
S03K0416X	RAU-EXP Rack 3 On	E	E	-	-

TABLE 1.- Continued

Command ID no.	Command name	Source			
		SM 3P	LM	5P	3P
S03K0417X	RAU-EXP Rack 3 Off	E	E	-	-
S03K0421X	RAU-EXP Rack 5 On	E	E	-	-
S03K0422X	RAU-EXP Rack 5 Off	E	E	-	-
S03K0426X	RAU-EXP Rack 6 On	E	E	-	-
S03K0427X	RAU-EXP Rack 6 Off	E	E	-	-
S03K0431X	RAU-EXP Rack 7 On	-	F	-	-
S03K0432X	RAU-EXP Rack 7 Off	-	F	-	-
S03K0436X	RAU-EXP Rack 8 On	-	F	-	-
S03K0437X	RAU-EXP Rack 8 Off	-	F	-	-
S03K0441X	RAU-EXP Rack 9 On	-	F	-	-
S03K0442X	RAU-EXP Rack 9 Off	-	F	-	-
S03K0446X	RAU-EXP Rack 10 On	-	F	-	-
S03K0447X	RAU-EXP Rack 10 Off	-	F	-	-
S03K0451X	RAU-EXP Rack 11 On	-	F	-	-
S03K0452X	RAU-EXP Rack 11 Off	-	F	-	-
S03K0456X	RAU-EXP Rack 12 On	-	F	-	-
S03K0457X	RAU-EXP Rack 12 Off	-	F	-	-
S03K0501X	RAU-EXP 1/Pallet 1 On	F	-	D	D
S03K0502X	RAU-EXP 1/Pallet 1 Off	F	-	D	D
S03K0506X	RAU-EXP 2/Pallet 1 On	F	-	D	D
S03K0507X	RAU-EXP 2/Pallet 1 Off	F	-	D	D
S03K0511X	RAU-EXP 3/Pallet 1 On	F	-	D	D

TABLE 1.- Continued

Command ID no.	Command name	Source			
		SM 3P	LM	5P	3P
S03K0512X	RAU-EXP 3/Pallet 1 Off	F	-	D	D
S03K0516X	RAU-EXP 4/Pallet 1 On	F	-	D	D
S03K0517X	RAU-EXP 4/Pallet 1 Off	F	-	D	D
S03K0521X	RAU-EXP 1/Pallet 2 On	G	-	E	E
S03K0522X	RAU-EXP 1/Pallet 2 Off	G	-	E	E
S03K0526X	RAU-EXP 2/Pallet 2 On	G	-	E	E
S03K0527X	RAU-EXP 2/Pallet 2 Off	G	-	E	E
S03K0531X	RAU-EXP 3/Pallet 2 On	G	-	E	E
S03K0532X	RAU-EXP 3/Pallet 2 Off	G	-	E	E
S03K0536X	RAU-EXP 4/Pallet 2 On	G	-	E	E
S03K0537X	RAU-EXP 4/Pallet 2 Off	G	-	E	E
S03K0541X	RAU-EXP 1/Pallet 3 On	H	-	F	F
S03K0542X	RAU-EXP 1/Pallet 3 Off	H	-	F	F
S03K0546X	RAU-EXP 2/Pallet 3 On	H	-	F	F
S03K0547X	RAU-EXP 2/Pallet 3 Off	H	-	F	F
S03K0551X	RAU-EXP 3/Pallet 3 On	H	-	F	F
S03K0552X	RAU-EXP 3/Pallet 3 Off	H	-	F	F
S03K0556X	RAU-EXP 4/Pallet 3 On	H	-	F	F
S03K0557X	RAU-EXP 4/Pallet 3 Off	H	-	F	F
S03K0561X	RAU-EXP 1/Pallet 4 On	-	-	G	-
S03K0562X	RAU-EXP 1/Pallet 4 Off	-	-	G	-
S03K0566X	RAU-EXP 2/Pallet 4 On	-	-	G	-

TABLE 1.- Continued

Command ID no.	Command name	Source			
		SM 3P	LM	5P	3P
S03K0567X	RAU-EXP 2/Pallet 4 Off	-	-	G	-
S03K0571X	RAU-EXP 3/Pallet 4 On	-	-	G	-
S03K0572X	RAU-EXP 3/Pallet 4 Off	-	-	G	-
S03K0576X	RAU-EXP 4/Pallet 4 On	-	-	G	-
S03K0577X	RAU-EXP 4/Pallet 4 Off	-	-	G	-
S03K0581X	RAU-EXP 1/Pallet 5 On	-	-	H	-
S03K0582X	RAU-EXP 1/Pallet 5 Off	-	-	H	-
S03K0586X	RAU-EXP 2/Pallet 5 On	-	-	H	-
S03K0587X	RAU-EXP 2/Pallet 5 Off	-	-	H	-
S03K0591X	RAU-EXP 3/Pallet 5 On	-	-	H	-
S03K0592X	RAU-EXP 3/Pallet 5 Off	-	-	H	-
S03K0596X	RAU-EXP 4/Pallet 5 On	-	-	H	-
S03K0597X	RAU-EXP 4/Pallet 5 Off	-	-	H	-
S03K0713X	Voice Digitizer PWR On	B	B	C	C
S03K0714X	Voice Digitizer PWR Off	B	B	C	C
S03K0715X	Voice Digitizer Ch.1 Enable	B	B	C	C
S03K0716X	Voice Digitizer Ch.1 Disable	B	B	C	C
S03K0717X	Voice Digitizer Ch.2 Enable	B	B	C	C
S03K0718X	Voice Digitizer Ch.2 Disable	B	B	C	C
S03K0719X	Voice Digitizer Ch.3 Enable	B	B	C	C
S03K0720X	Voice Digitizer Ch.3 Disable	B	B	C	C
S03K0731X	HRDR PWR On	A	A	A	A

TABLE 1.- Concluded

Command ID no.	Command name	Source			
		SM 3P	LM	5P	3P
S03K0732X	HRDR PWR Off	A	A	A	A
S03K0733X	HRDR Stop	A	A	A	A
S03K0741X	HRDR Record	A	A	A	A
S03K0742X	HRDR Replay	A	A	A	A
S03K0743X	HRDR Erase	A	A	A	A
S03K0744X	HRDR Fast Forward	A	A	A	A
S03K0745X	HRDR Fast Rewind	A	A	A	A
S03K0751X	HRDR Rate 1-2 mbps	A	A	A	A
S03K0752X	HRDR Rate 2-4 mbps	A	A	A	A
S03K0753X	HRDR Rate 4-8 mbps	A	A	A	A
S03K0754X	HRDR Rate 8-16 mbps	A	A	A	A
S03K0755X	HRDR Rate 16-32 mbps	A	A	A	A
S03K0761X	HRDR Self Test	A	A	A	A

TABLE 2.- SPACELAB MASTER MEASUREMENT LIST

(a) Subsystem S03: control and data management subsystem

Measurement ID no.	Measurement name	Data range			Destination			
		Eng. unit	Low	High	SM 3P	LM	5P	3P
S03X0101Y	SS-COMP PWR On	Event	OFF	ON	MR	MR	MR	MR
S03X0105Y	SS-COMP AUTO START On	Event	OFF	ON	M	M	M	M
S03X0108Y	SS-COMP Load Executed	Event	NOGO	GO	MR	MR	MR	MR
S03C0111C	SS-COMP Prim. Current	Amp	0	30	C	C	B	B
S03T0112C	SS-COMP CPU TEMP	Deg C	-40	+100	C	C	B	B
S03T0113C	SS-COMP Memory TEMP	Deg C	-40	+100	C	C	B	B
S03V0114C	SS-COMP PWR Supply +5V	VDC	0	6	C	C	B	B
S03V0115C	SS-COMP PWR Supply -5V	VDC	0	-6	C	C	B	B
S03X0121X	SS-COMP PWR Network	Event	NOGO	GO	C	C	B	B
S03X0122X	SS-COMP SEC PWR	Event	NOGO	GO	C	C	B	B
S03X0123X	SS-COMP Internal TEMP	Event	NOGO	GO	C	C	B	B
S03X0131Y	BU-COMP PWR On	Event	OFF	ON	NR	NR	NR	NR
S03X0133X	BU-COMP PWR On	Event	OFF	ON	CR	CR	BR	BR
S03X0135X	BU-COMP AUTO START On	Event	OFF	ON	C	C	B	B
S03X0135Y	BU-COMP AUTO START On	Event	OFF	ON	N	N	N	N
S03X0138X	BU-COMP Load Executed	Event	NOGO	GO	CR	CR	BR	BR
S03X0138Y	BU-COMP Load Executed	Event	NOGO	GO	NR	NR	NR	NR
S03C0141C	BU-COMP Prim. Current	Amp	0	30	D	D	C	C

TABLE 2.- Continued

(a) Continued

Measurement ID no.	Measurement name	Data range			Destination			
		Eng. unit	Low	High	SM 3P	LM	5P	3P
S03T0142C	BU-COMP CPU TEMP	Deg C	-40	+100	D	D	C	C
S03T0143C	BU-COMP Memory TEMP	Deg C	-40	+100	D	D	C	C
S03V0144C	BU-COMP PWR Supply +5V	VDC	0	6	D	D	C	C
S03V0145C	BU-COMP PWR Supply -5V	VDC	0	-6	D	D	C	C
S03X0151X	BU-COMP PWR Network	Event	NOGO	GO	D	D	C	C
S03X0152X	BU-COMP SEC PWR	Event	NOGO	GO	D	D	C	C
S03X0153X	BU-COMP Internal TEMP	Event	NOGO	GO	D	D	C	C
S03X0161X	EXP-COMP PWR On	Event	OFF	ON	DR	DR	CR	CR
S03X0165X	EXP-COMP AUTO START On	Event	OFF	ON	D	D	C	C
S03X0168X	EXP-COMP Load Executed	Event	NOGO	GO	DR	DR	CR	CR
S03C0171C	EXP-COMP Prim. Current	Amp	0	30	D	D	C	C
S03T0172C	EXP-COMP CPU TEMP	Deg C	-40	+100	D	D	C	C
S03T0173C	EXP-COMP Memory TEMP	Deg C	-40	+100	D	D	C	C
S03V0174C	EXP-COMP PWR Supply +5V	VDC	0	6	D	D	C	C
S03V0175C	EXP-COMP PWR Supply -5V	VDC	0	-6	D	D	C	C
S03X0181X	EXP-COMP PWR Network	Event	NOGO	GO	D	D	C	C
S03X0182X	EXP-COMP SEC PWR	Event	NOGO	GO	D	D	C	C
S03X0183X	EXP-COMP Internal TEMP	Event	NOGO	GO	D	D	C	C
S03X0191X	MMU PWR On	Event	OFF	ON	CR	CR	BR	BR
S03X0191Y	MMU PWR On	Event	OFF	ON	MR	MR	MR	MR
S03T0133C	MMU TEMP	Deg C			B	B	B	B

TABLE 2.- Continued

(a) Continued

Measurement ID no.	Measurement name	Data range			Destination			
		Eng. unit	Low	High	SM 3P	LM	5P	3P
S03V0135C	MMU SEC Voltage	VDC			B	B	B	B
S03X0201Y	I/O-SS PWR A On	Event	OFF	ON	MR	MR	MR	MR
S03X0202Y	I/O-SS PWR B On	Event	OFF	ON	NR	NR	NR	NR
S03X0211Y	I/O-SS MDM Coupler B On	Event	OFF	ON	NR	NR	NR	NR
S03X0212Y	I/O-SS PCMMU Coupler B On	Event	OFF	ON	NR	NR	NR	NR
S03X0213Y	I/O-SS MMU Coupler B On	Event	OFF	ON	NR	NR	NR	NR
S03X0214Y	I/O-SS RAU Coupler B On	Event	OFF	ON	NR	NR	NR	NR
S03X0215Y	I/O-SS DDU/KBD Coupler B On	Event	OFF	ON	NR	NR	NR	NR
S03X0216Y	I/O-SS Time-Coupler On	Event	OFF	ON	MR	MR	MR	MR
S03X0221Y	I/O-SS DMA-IOCU to BU COMP	Event		CONN	NR	NR	NR	NR
S03X0222Y	I/O-SS MDM Coupler BITE	Event	NOGO	GO	MR	MR	MR	MR
S03X0223Y	I/O-SS PCMMU Coupler BITE	Event	NOGO	GO	MR	MR	MR	MR
S03X0224Y	I/O-SS MMU Coupler BITE	Event	NOGO	NO	MR	MR	MR	MR
S03X0225Y	I/O-SS DMA-IOCU BITE	Event	NOGO	NO	MR	MR	MR	MR
S03C0231C	I/O-SS Input Current A	Amp			C	C	B	B
S03C0232C	I/O SS Input Current B	Amp			C	C	B	B
S03T0233C	I/O-SS TEMP	Deg C			C	C	B	B

Three possible additional measurements might be

I/O - SS HRM Coupler B ON (OFF, ON) (Y, NR, NR, NR, NR)
 I/O - EXP HRM Coupler B ON (OFF, ON) (X, CR, CR, BR, BR)
 I/O - SS DMA - IOCU to SS COMP (CONN) (Y, NR, NR, NR, NR)

Three possible additional measurements might be
 KBi to SS COMP (CONN)
 where i = 1, 2, 3

Three possible additional measurements might be
 KBi to EXP COMP (CONN)
 where i = 1, 2, 3

Nine possible additional measurements might be
 KBi to DDUj
 where
 i = 1, 2, 3
 j = 1, 2, 3

TABLE 2.- Continued

(a) Continued

Measurement ID no.	Measurement name	Data range			Destination			
		Eng. unit	Low	High	SM 3P	LM	5P	3P
S03V0234C	I/O-SS SEC PWR Supply +5V	VDC			C	C	B	B
S03V0235C	I/O-SS SEC PWR Supply -5V	VDC			C	C	B	B
S03V0236C	I/O-SS SEC PWR Supply +12V	VDC			C	C	B	B
S03X0251X	I/O-EXP PWR A On	Event	OFF	ON	DR	DR	CR	CR
S03X0252X	I/O-EXP PWR B On	Event	OFF	ON	CR	CR	BR	BR
S03X0261X	I/O-EXP MDM Coupler B On	Event	OFF	ON	CR	CR	BR	BR
S03X0262X	I/O-EXP PCMMU Coupler B On	Event	OFF	ON	CR	CR	BR	BR
S03X0263X	I/O-EXP MMU Coupler B On	Event	OFF	ON	CR	CR	BR	BR
S03X0264X	I/O-EXP RAU Coupler B On	Event	OFF	ON	CR	CR	BR	BR
S03X0265X	I/O-EXP DDU/KBD Coupler B On	Event	OFF	ON	CR	CR	BR	BR
S03X0266X	I/O-EXP Time-Coupler On	Event	OFF	ON	BR	BR	CR	CR
S03X0271X	I/O-EXP DMA-IOCU to BU COMP	Event		CONN	CR	CR	BR	BR
S03X0272X	I/O-EXP MDM Coupler BITE	Event	NOGO	GO	DR	DR	CR	CR
S03X0273X	I/O-EXP PCMMU Coupler BITE	Event	NOGO	GO	DR	DR	CR	CR
S03X0274X	I/O-EXP MMU Coupler BITE	Event	NOGO	GO	DR	DR	CR	CR
S03X0275X	I/O-EXP DMA-IOCU BITE	Event	NOGO	GO	DR	DR	CR	CR
S03C0281C	I/O-EXP Input Current A	Amp			B	B	C	C
S03C0282C	I/O-EXP Input Current B	Amp			B	B	C	C
S03V0284C	I/O-EXP SEC PWR Supply +5V	VDC			B	B	C	C
S03V0285C	I/O-EXP SEC PWR Supply -5V	VDC			B	B	C	C

A possible additional measurement might be
I/O-EXP DMA-IOCU to EXP COMP (CONN) (X,CR,CR,BR,BR,)

TABLE 2.- Continued

(a) Continued

Measurement ID no.	Measurement name	Data range			Destination			
		Eng. unit	Low	High	SM 3P	LM	5P	3P
S03V0286C	I/O-EXP SEC PWR Supply +12V	VDC			B	B	C	C
S03X0311Y	RAU-SS A On	Event	OFF	ON	MR	MR	MR	MR
S03X0316Y	RAU-SS B On	Event	OFF	ON	MR	MR	MR	MR
S03T0283C	I/O-EXP TEMP	Deg C			D	D	C	C
S03X0321Y	RAU-SS C On	Event	OFF	ON	MR	MR	MR	MR
S03X0326Y	RAU-SS D On	Event	OFF	ON	MR	MR	MR	MR
S03X0331Y	RAU-SS E On	Event	OFF	ON	MR	MR	MR	MR
S03X0336Y	RAU-SS F On	Event	OFF	ON	MR	MR	MR	MR
S03X0341Y	RAU-SS G On	Event	OFF	ON	MR	-	MR	-
S03X0346Y	RAU-SS H On	Event	OFF	ON	MR	-	MR	-
S03X0406X	RAU-EXP Top Airlock On	Event	OFF	ON	-	B	-	-
S03X0411X	RAU-EXP Rack 2 On	Event	OFF	ON	E	E	-	-
S03X0416X	RAU-EXP Rack 3 On	Event	OFF	ON	E	E	-	-
S03X0421X	RAU-EXP Rack 5 On	Event	OFF	ON	E	E	-	-
S03X0426X	RAU-EXP Rack 6 On	Event	OFF	ON	E	E	-	-
S03X0431X	RAU-EXP Rack 7 On	Event	OFF	ON	-	F	-	-
S03X0436X	RAU-EXP Rack 8 On	Event	OFF	ON	-	F	-	-
S03X0441X	RAU-EXP Rack 9 On	Event	OFF	ON	-	F	-	-
S03X0446X	RAU-EXP Rack 10 On	Event	OFF	ON	-	F	-	-
S03X0451X	RAU-EXP Rack 11 On	Event	OFF	ON	-	F	-	-
S03X0456X	RAU-EXP Rack 12 On	Event	OFF	ON	-	F	-	-

TABLE 2.- Continued

(a) Continued

Measurement ID no.	Measurement name	Data range			Destination			
		Eng. unit	Low	High	SM 3P	LM	5P	3P
S03X0501X	RAU-EXP 1/Pallet 1 On	Event	OFF	ON	F	-	D	D
S03X0506X	RAU-EXP 2/Pallet 1 On	Event	OFF	ON	F	-	D	D
S03X0511X	RAU-EXP 3/Pallet 1 On	Event	OFF	ON	F	-	D	D
S03X0516X	RAU-EXP 4/Pallet 1 On	Event	OFF	ON	F	-	D	D
S03X0521X	RAU-EXP 1/Pallet 2 On	Event	OFF	ON	G	-	E	E
S03X0526X	RAU-EXP 2/Pallet 2 On	Event	OFF	ON	G	-	E	E
S03X0531X	RAU-EXP 3/Pallet 2 On	Event	OFF	ON	G	-	E	E
S03X0536X	RAU-EXP 4/Pallet 2 On	Event	OFF	ON	G	-	E	E
S03X0541X	RAU-EXP 1/Pallet 3 On	Event	OFF	ON	H	-	F	F
S03X0546X	RAU-EXP 2/Pallet 3 On	Event	OFF	ON	H	-	F	F
S03X0551X	RAU-EXP 3/Pallet 3 On	Event	OFF	ON	H	-	F	F
S03X0556X	RAU-EXP 4/Pallet 3 On	Event	OFF	ON	H	-	F	F
S03X0561X	RAU-EXP 1/Pallet 4 On	Event	OFF	ON	-	-	G	-
S03X0566X	RAU-EXP 2/Pallet 4 On	Event	OFF	ON	-	-	G	-
S03X0571X	RAU-EXP 3/Pallet 4 On	Event	OFF	ON	-	-	G	-
S03X0576X	RAU-EXP 4/Pallet 4 On	Event	OFF	ON	-	-	G	-
S03X0581X	RAU-EXP 1/Pallet 5 On	Event	OFF	ON	-	-	H	-
S03X0586X	RAU-EXP 2/Pallet 5 On	Event	OFF	ON	-	-	H	-
S03X0591X	RAU-EXP 3/Pallet 5 On	Event	OFF	ON	-	-	H	-
S03X0596X	RAU-EXP 4/Pallet 5 On	Event	OFF	ON	-	-	H	-
S03V0601C	KBD 1 PWR Supply Voltage	VAC			A	A	A	A

TABLE 2.- Continued

(a) Continued

Measurement ID no.	Measurement name	Data range			Destination			
		Eng. unit	Low	High	SM 3P	LM	5P	3P
S03C0602C	KBD 1 PWR Supply Current	Amp			A	A	A	A
S03X0603X	KBD 1 BITE	Event	NOGO	GO	A	A	A	A
S03X0604X	KBD 1 PWR Surge Over/Under Voltage	Event	O/U		A	A	A	A
S03C0611C	DDU 1 PWR Supply Current	Amp			A	A	A	A
S03X0612X	DDU 1 BITE	Event	NOGO	GO	A	A	A	A
S03X0613X	DDU 1 Phosphor Protection	Event	NOGO	GO	A	A	A	A
S03X0614X	DDU 1 PWR Surge Over/Under Voltage	Event	O/U		A	A	A	A
S03V0615C	DDU 1 SEC Voltage 1	VDC			A	A	A	A
S03V0616C	DDU 1 SEC Voltage 2	VDC			A	A	A	A
S03V0617C	DDU 1 SEC Voltage 3	VDC			A	A	A	A
S03V0618C	DDU 1 SEC Voltage 4	VDC			A	A	A	A
S03V0619C	DDU 1 SEC Voltage 5	VDC			A	A	A	A
S03V0631C	KBD 2 PWR Supply Voltage	VAC			B	B	-	-
S03C0632C	KBD 2 PWR Supply Current	Amp			B	B	-	-
S03X0633X	KBD 2 BITE	Event	NOGO	GO	B	B	-	-
S03X0634X	KBD 2 PWR Surge Over/Under Voltage	Event	O/U		B	B	-	-
S03C0641C	DDU 2 PWR Supply Current	Amp			B	B	-	-
S03X0642X	DDU 2 BITE	Event	NOGO	GO	B	B	-	-
S03X0643X	DDU 2 Phosphor Protection	Event	NOGO	GO	B	B	-	-

TABLE 2.- Continued

(a) Continued

Measurement ID no.	Measurement name	Data range			Destination			
		Eng. unit	Low	High	SM 3P	LM	5P	3P
S03X0644X	DDU 2 PWR Surge Over/Under Voltage	Event	O/U		B	B	-	-
S03V0645C	DDU 2 SEC Voltage 1	VDC			B	B	-	-
S03V0646C	DDU 2 SEC Voltage 2	VDC			B	B	-	-
S03V0647C	DDU 2 SEC Voltage 3	VDC			B	B	-	-
S03V0648C	DDU 2 SEC Voltage 4	VDC			B	B	-	-
S03V0649C	DDU 2 SEC Voltage 5	VDC			B	B	-	-
S03V0661C	KBD 3 PWR Supply Voltage	VAC			D	D	-	-
S03C0662C	KBD 3 PWR Supply Current	Amp			D	D	-	-
S03X0663X	KBD 3 BITE	Event	NOGO	GO	D	D	-	-
S03X0664X	KBD 3 PWR Surge Over/Under Voltage	Event	O/U		D	D	-	-
S03C0671C	DDU 3 PWR Supply Current	Amp			D	D	-	-
S03X0672X	DDU 3 BITE	Event	NOGO	GO	D	D	-	-
S03X0673X	DDU 3 Phosphor Protection	Event	NOGO	GO	D	D	-	-
S03X0674X	DDU 3 PWR Surge Over/Under Voltage	Event	O/U		D	D	-	-
S03V0675C	DDU 3 SEC Voltage 1	VDC			D	D	-	-
S03V0676C	DDU 3 SEC Voltage 2	VDC			D	D	-	-
S03V0677C	DDU 3 SEC Voltage 3	VDC			D	D	-	-
S03V0678C	DDU 3 SEC Voltage 4	VDC			D	D	-	-
S03V0679C	DDU 3 SEC Voltage 5	VDC			D	D	-	-

TABLE 2.- Continued

(a) Continued

Measurement ID no.	Measurement name.	Data range			Destination			
		Eng. unit	Low	High	SM 3P	LM	5P	3P
S03V0701C	Intercom Master PWR Supply 1 Voltage	VDC			B	B	-	-
S03V0702C	Intercom Master PWR Supply 2 Voltage	VDC			B	B	-	-
S03V0703C	Intercom Master PWR Supply 3 Voltage	VDC			B	B	-	-
S03V0704C	Intercom Master PWR Supply 4 Voltage	VDC			B	B	-	-
S03V0711C	Voice Digit. PWR Supply 1 Voltage	VDC			B	B	C	C
S03V0712C	Voice Digit. PWR Supply 2 Voltage	VDC			B	B	C	C
S03X0713X	Voice Digit. PWR On	Event	OFF	ON	B	B	C	C
S03X0715X	Voice Digit. Channel 1 Enabled	Event	NOGO	GO	B	B	C	C
S03X0717X	Voice Digit. Channel 2 Enabled	Event	NOGO	GO	B	B	C	C
S03X0719X	Voice Digit. Channel 3 Enabled	Event	NOGO	GO	B	B	C	C
S03X0731X	HRDR PWR On	Event	OFF	ON	A	A	A	A
S03X0734X	HRDR Tape Status	Event	NOGO	GO	A	A	A	A
S03X0735X	HRDR End-of-Tape Reached	Event	EOT		A	A	A	A
S03X0736X	HRDR Begin-of-Tape Reached	Event	BOT		A	A	A	A
S03X0737X	HRDR Servo Sync	Event	NOGO	GO	A	A	A	A
S03X0741X	HRDR Record	Event	OFF	ON	A	A	A	A
S03X0742X	HRDR Replay	Event	OFF	ON	A	A	A	A

TABLE 2.- Continued

(a) Continued

Measurement ID no.	Measurement name	Data range			Destination			
		Eng. unit	Low	High	SM 3P	LM	5P	3P
S03X0743X	HRDR Erase	Event	OFF	ON	A	A	A	A
S03X0746X	HRDR Fast Operation	Event	OFF	ON	A	A	A	A
S03X0747X	HRDR Forward	Event	NOGO	GO	A	A	A	A
S03X0748X	HRDR Reverse	Event	NOGO	GO	A	A	A	A
S03X0751X	HRDR Rate Selected 2 mbps	Event	OFF	ON	A	A	A	A
S03X0752X	HRDR Rate Selected 4 mbps	Event	OFF	ON	A	A	A	A
S03X0753X	HRDR Rate Selected 8 mbps	Event	OFF	ON	A	A	A	A
S03X0754X	HRDR Rate Selected 16 mbps	Event	OFF	ON	A	A	A	A
S03X0755X	HRDR Rate Selected 32 mbps	Event	OFF	ON	A	A	A	A
S03X0761X	HRDR EU BITE	Event	NOGO	GO	A	A	A	A
S03X0762X	HRDR TU BITE	Event	NOGO	GO	A	A	A	A
S03X0763X	HRDR Self Test Busy	Event	BUSY		A	A	A	A
S03X0764X	HRDR Local Control Busy	Event	BUSY		A	A	A	A
S03X0765X	HRDR PWR Supply Status	Event	NOGO	GO	A	A	A	A
S03C0771C	HRDR Motor Current	Amp			A	A	A	A
S03T0772C	HRDR Int. TEMP	Deg C			A	A	A	A
S03V0774C	HRDR SEC Voltage 1	VDC			A	A	A	A
S03X0781X	HRDR Tape Footage Indic. Bit 1	Event	0	1	A	A	A	A
S03X0782X	HRDR Tape Footage Indic. Bit 2	Event	0	1	A	A	A	A
S03X0783X	HRDR Tape Footage Indic. Bit 3	Event	0	1	A	A	A	A

TABLE 2.- Continued

(a) Concluded

Measurement ID no.	Measurement name	Data range			Destination			
		Eng. unit	Low	High	SM 3P	LM	5P	3P
S03X0784X	HRDR Tape Footage Indic. Bit 4	Event	0	1	A	A	A	A
S03X0785X	HRDR Tape Footage Indic. Bit 5	Event	0	1	A	A	A	A
S03X0786X	HRDR Tape Footage Indic. Bit 6	Event	0	1	A	A	A	A
S03X0787X	HRDR Tape Footage Indic. Bit 7	Event	0	1	A	A	A	A
S03X0788X	HRDR Tape Footage Indic. Bit 8	Event	0	1	A	A	A	A

TABLE 2.- Concluded

(b) Subsystem S04: system activation and monitoring/common payload support equipment/structure

Measurement ID no.	Measurement name	Data range			Destination			
		Eng. unit	Low	High	SM	3P	LM	5P
S05V0101C	RAAB 28V Bus 1 Voltage	VDC	0	40	B	B	B	B
S05V0101V	RAAB 28V Bus 1 Voltage	VDC	0	40	M	M	M	M
S05V0102C	RAAB 28V Bus 2 Voltage	VDC	0	40	B	B	B	B
S05V0102V	RAAB 28V Bus 2 Voltage	VDC	0	40	M	M	M	M
S05V0103C	RAAB 6V Bus 1 Voltage	VDC	0	10	B	B	B	B
S05V0104C	RAAB 6V Bus 2 Voltage	VDC	0	10	B	B	B	B
S05V0105C	RAAB +10V Bus Voltage	VDC	0	15	B	B	B	B
S05V0106C	RAAB -10V Bus Voltage	VDC	0	-15	B	B	B	B

Two possible additional measurements might be

RAAB 6V Bus 3 Voltage (VDC, 0, 10) (C, B, B, B, B)

RAAB 6V Bus 4 Voltage (VDC, 0, 10) (C, B, B, B, B)

TABLE 3.- COST OF FEATURES OF DISPLAYS IN A DYNAMIC ENVIRONMENT

Feature	Memory cost, in half words
Position, 1 coordinate (X=)	3
Position, 2 coordinates (X=,Y=)	4
Character string of N standard characters (without positioning)	$\frac{N}{2}$ (round up)+1
Single special character (without positioning)	3
Circle (static radius, without positioning)	3
Line (with positioning)	5
Variable parameter (VPARM) (without positioning)	3
Dash	3
Test	3
Branch	2
RTC	3
Item number (with positioning, without limits, with display of item number)	9

TABLE 4.- SCHEMATIC DISPLAY WITH LABELS AND TUTORIALS

Feature		Number	Cost, in half words
Character pairs	Labels	25	70
	Tutorials	12	58
Character strings	Labels	13	13
	Tutorials	12	12
Lines	Display	22	110
	Tutorials	6	30
Circles	Display	2	14
	Tutorials	12	82
Item numbers		2	18
VPARAM		2	14
Special characters, arrows	Display	2	14
	Tutorials	2	14
Tests		4	36
Total cost			<u>485</u>

WITHOUT LABELS AND TUTORIALS

Feature	Number	Cost, in half words
Character pairs	4	11
Character strings	2	2
Lines	22	110
Circles	2	14
Item numbers	2	18
VPARAM	2	14
Special characters, arrows	2	14
Tests	4	36
Total cost		<u>219</u>

TABLE 6.- MMU TABULAR DISPLAY

Feature	Number	Cost, in half words
Character pairs	31	87
Character strings	16	16
Lines	11	55
Item numbers	2	18
VPARAM	2	14
Tests and indicators	8	68
Total cost		<u>258</u>

48

ORIGINAL PAGE IS
OF POOR QUALITY

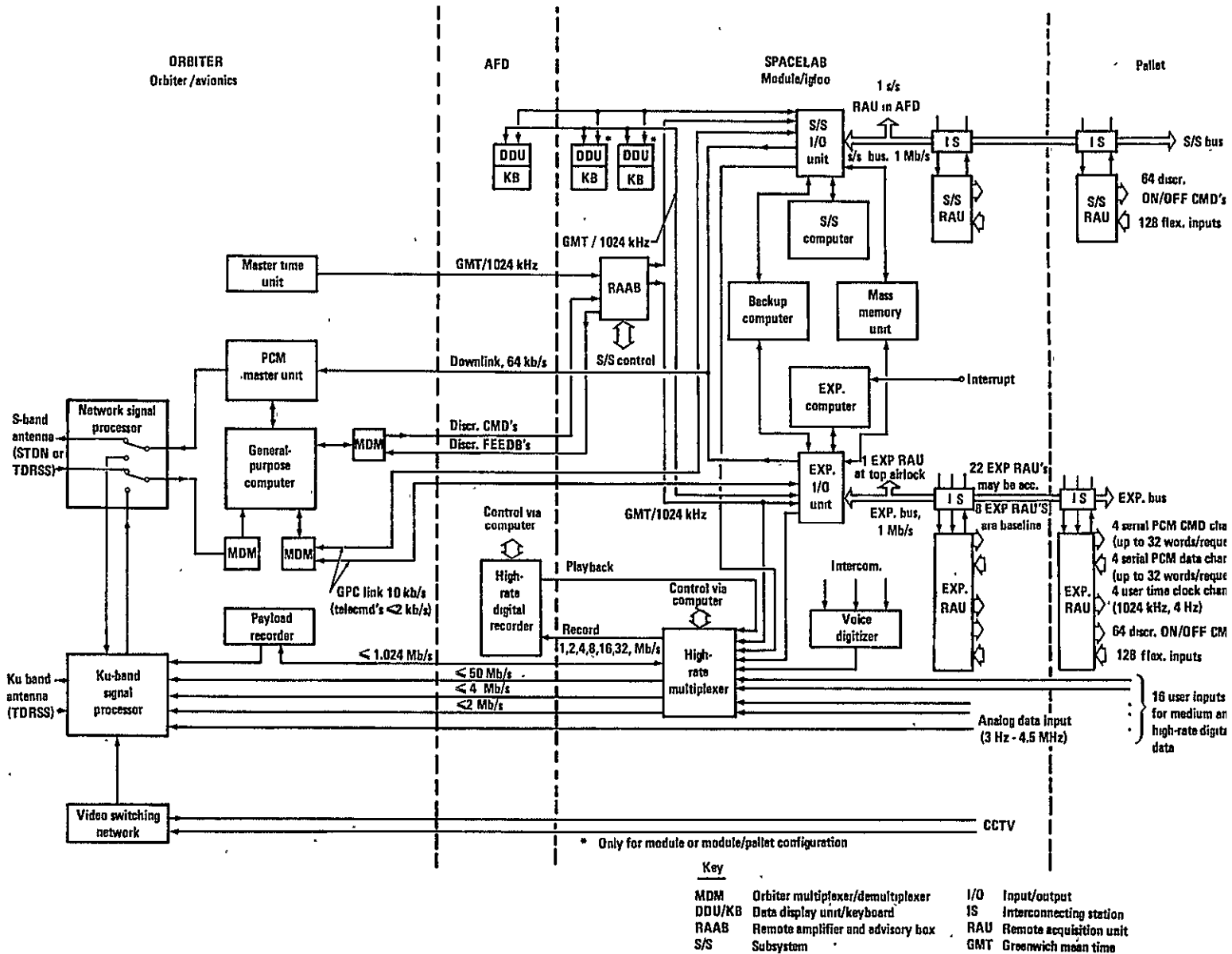

Figure 1.- CDMS block diagram.

CDMS

CDMS

1,1

C- CDMS Master PWR Off (Y, NR, NR, NR, NR) (the effect of this command is not indicated in the rest of the matrix)

SS COMP

2,2

SS COMP

C- SS COMP PWR On/SS DMA to SS COMP (Y, MR, MR, MR, MR)
 SS COMP PWR Off/AUTO RESTART Off (Y, MR, MR, MR, MR)
 SS COMP AUTO RESTART On (Y, M, M, M, M)
 SS COMP Reload Via MMU (Y, MR, MR, MR, MR)
 SS COMP Reload Via MDM (Y, MR, MR, MR, MR)
 M- SS COMP PWR On (OFF, ON) (Y, MR, MR, MR, MR)
 SS COMP Prim. Current (Amps, 0, 30) (C, C, C, B, B)
 SS COMP PWR Supply +5V (VDC, 0, 6) (C, C, C, B, B)
 SS COMP PWR Supply -5V (VDC, 0, -6) (C, C, C, B, B)
 SS COMP PWR Network (NOGO, GO) (X, C, C, B, B)
 SS COMP Secondary PWR (NOGO, GO) (X, C, C, B, B)
 SS COMP Internal TEMP (NOGO, GO) (X, C, C, B, B)
 SS COMP AUTO START On (OFF, ON) (Y, M, M, M, M)
 SS COMP Load Executed (NOGO, GO) (Y, MR, MR, MR, MR)

(a) 1,1 and 2,2.

Figure 4.- Expanded-matrix elements (C = command, M = measurement, H = hardware link, S = switch, D = DPS, dlb = directly linked by (implies a direct link between the two specified units of the subsystem), dltb = directly linked together by (implies an indirect link between the two specified units of the subsystem; a third unit of the subsystem exists in the link between the two specified units), and dcov = direct control over via (the link between the two specified units of the subsystem is directly controlled by the unit indicated)).

2,4

SS COMP

SS I/O
C- SS COMP PWR On/SS DMA to SS COMP (Y, MR, MR, MR, MR)

2,4

SS COMP

KB1	KB2	KB3
S- KB1 to SS COMP	S- KB2 to SS COMP	S- KB3 to SS COMP
M- KB1 to SS COMP Via SS I/O and KB Couplers (CONN)	M- KB2 to SS COMP Via SS I/O and KB Couplers (CONN)	M- KB3 to SS COMP Via SS I/O and KB Couplers (CONN)

2,13

(b) 2,4 and 2,13.

Figure 4.- Continued.

EXP COMP

3,3

C- EXP COMP PWR On/EXP DMA to EXP COMP (X, DR, DR, CR, CR)
 EXP COMP PWR Off/AUTO RESTART Off (X, DR, DR, CR, CR)
 EXP COMP AUTO RESTART On (X, D, D, C, C)
 EXP COMP Reload Via MMU (X, DR, DR, CR, CR)
 EXP COMP Reload Via MDM (X, DR, DR, CR, CR)

M- EXP COMP PWR On (OFF, ON) (X, DR, DR, CR, CR)
 EXP COMP Primary Current (Amps, 0, 30) (C, D, D, C, C)
 EXP COMP PWR Supply +5V (VDC, 0, 6) (C, D, D, C, C)
 EXP COMP PWR Supply -5V (VDC, 0, -6) (C, D, D, C, C)
 EXP COMP PWR Network (NOGO, GO) (X, D, D, C, C)
 EXP COMP Secondary PWR (NOGO, GO) (X, D, D, C, C)
 EXP COMP Internal TEMP (NOGO, GO) (X, D, D, C, C)
 EXP COMP AUTO START On (OFF, ON) (X, D, D, C, C)
 EXP COMP Load-Execute (NOGO, GO) (X, DR, DR, CR, CR)

EXP I/O

3,5

C- EXP COMP PWR On/EXP DMA to EXP COMP (X, DR, DR, CR, CR)

(c) 3,3 and 3,5.

Figure 4.- Continued.

55

EXP COMP

KB1	KB2	KB3
S- KB1 to EXP COMP M- KB1 to EXP COMP Via EXP I/O and KB Couplers (CONN)	S- KB2 to EXP COMP M- KB2 to EXP COMP Via EXP I/O and KB Couplers (CONN)	S- KB3 to EXP COMP M- KB3 to EXP COMP Via EXP I/O and KB Couplers (CONN)

3,13

SS I/O

SS I/O
M- SS I/O Input Current A (Amps) (C, C, C, B, B) SS I/O Input Current B (Amps) (C, C, C, B, B) SS I/O TEMP (Deg C) (C, C, C, B, B) SS I/O Secondary PWR Supply +5V (VDC) (C, C, C, B, B) SS I/O Secondary PWR Supply -5V (VDC) (C, C, C, B, B) SS I/O Secondary PWR Supply +12V (VDC) (C, C, C, B, B)

4,4

(d) 3,13 and 4,4.

Figure 4.- Continued.

SS I/O

BU COMP

4,6

C- BU COMP PWR On/SS DMA to BU COMP (Y, NR, NR, NR, NR)

EXP I/O

5,5

EXP I/O

M- EXP I/O Input Current A (Amps) (C, B, B, C, C)
EXP I/O Input Current B (Amps) (C, B, B, C, C)
EXP I/O Secondary PWR Supply +5V (VDC) (C, B, B, C, C)
EXP I/O Secondary PWR Supply -5V (VDC) (C, B, B, C, C)
EXP I/O Secondary PWR Supply +12 (VDC) (C, B, B, C, C)
EXP I/O TEMP (Deg C) (C, D, D, C, C)

(e) 4,6 and 5,5.

Figure 4.- Continued.

BU COMP

5,6

BU COMP

6,6

C- BU COMP PWR On/EXP DMA to BU COMP (X, CR, CR, BR, BR)

C- BU COMP PWR On/SS DMA to BU COMP (Y, NR, NR, NR, NR)
 BU COMP AUTO RESTART On (X, C, C, B, B) (Y, N, N, N, N)
 BU COMP Reload Via MMU (X, CR, CR, BR, BR) (Y, NR, NR, NR, NR)
 BU COMP PWR On/EXP DMA to BUCOMP (X, CR, CR, BR, BR)
 BU COMP Reload Via MDM (X, CR, CR, BR, BR) (Y, NR, NR, NR, NR)
 BU COMP PWR Off/AUTO RESTART Off (Y, MR, MR, MR, MR)
 M- BU COMP PWR On (OFF, ON) (Y, NR, NR, NR, NR) (X, CR, CR, BR, BR)
 BU COMP AUTO START On (OFF, ON) (X, C, C, B, B) (Y, N, N, N, N)
 BU COMP Primary Current (Amps, 0, 30) (C, D, D, C, C)
 BU COMP Load Executed (NOGO, GO) (X, CR, CR, BR, BR) (Y, NR, NR, NR, NR)
 BU COMP PWR Supply +5V (VDC, 0, 6) (C, D, D, C, C)
 BU COMP PWR Supply -5V (VDC, 0, -6) (C, D, D, C, C)
 BU COMP PWR Network (NOGO, GO) (X, D, D, C, C)
 BU COMP Secondary PWR (NOGO, GO) (X, D, D, C, C)
 BU COMP Internal TEMP (NOGO, GO) (X, D, D, C, C)

EXP I/O

BU COMP

57

(f) 5,6 and 6,6.

Figure 4.- Continued.

MMU	
C-	MMU PWR On (Y, MR, MR, MR, MR) (X, CR, CR, BR, BR)
	MMU PWR Off (Y, MR, MR, MR, MR) (X, CR, CR, BR, BR)
M-	MMU PWR On (OFF, ON) (Y, MR, MR, MR, MR) (X, CR, CR, CR, CR)
	MMU TEMP (Deg C, -, -) (C, B, B, B, B)
	MMU Secondary Voltage (VDC, -, -) (C, B, B, B, B)

7,7

SS I/O MMU coupler A	SS I/O MMU coupler B
H-	H-
dlb data bus and procedure lines	dlb data bus and procedure lines

7,25

(g) 7,7 and 7,25

Figure 4.- Continued.

MMU

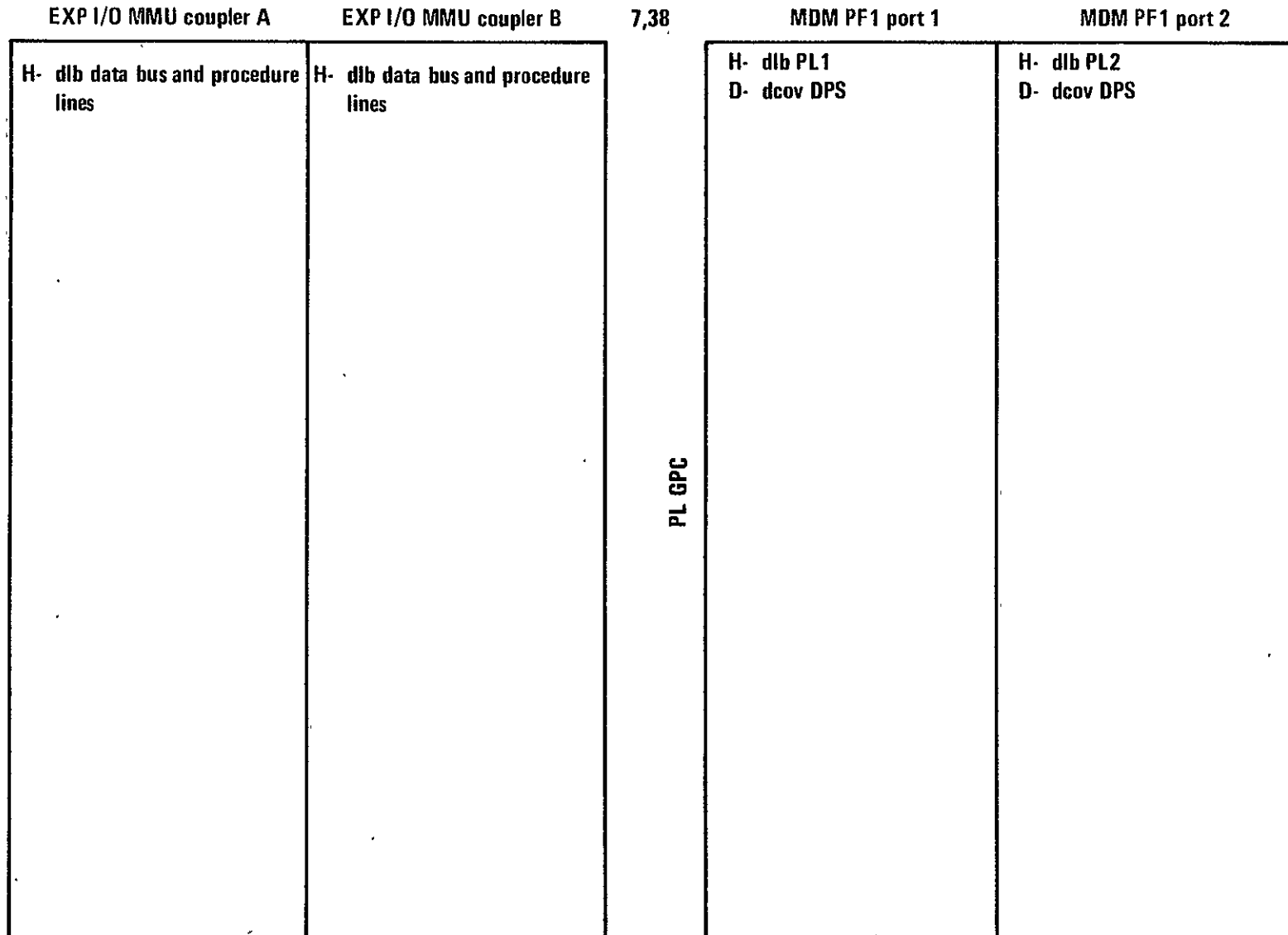

PL GPC

(h) 7,38 and 8,9.

Figure 4.- Continued.

09

PL GPC

MDM PF2 port 1	MDM PF2 port 2
H- dlb PL1 D- dcov DPS	H- dlb PL2 D- dcov DPS

8,10

MDM PF1 port 1

MDM PF2 port 2

MDM PF2 port 1	MDM PF2 port 2
H- dlrb PL1	
	H- dlrb PL2

9,10

(i) 8,10 and 9,10.

Figure 4.- Continued.

T9

MDM PF1

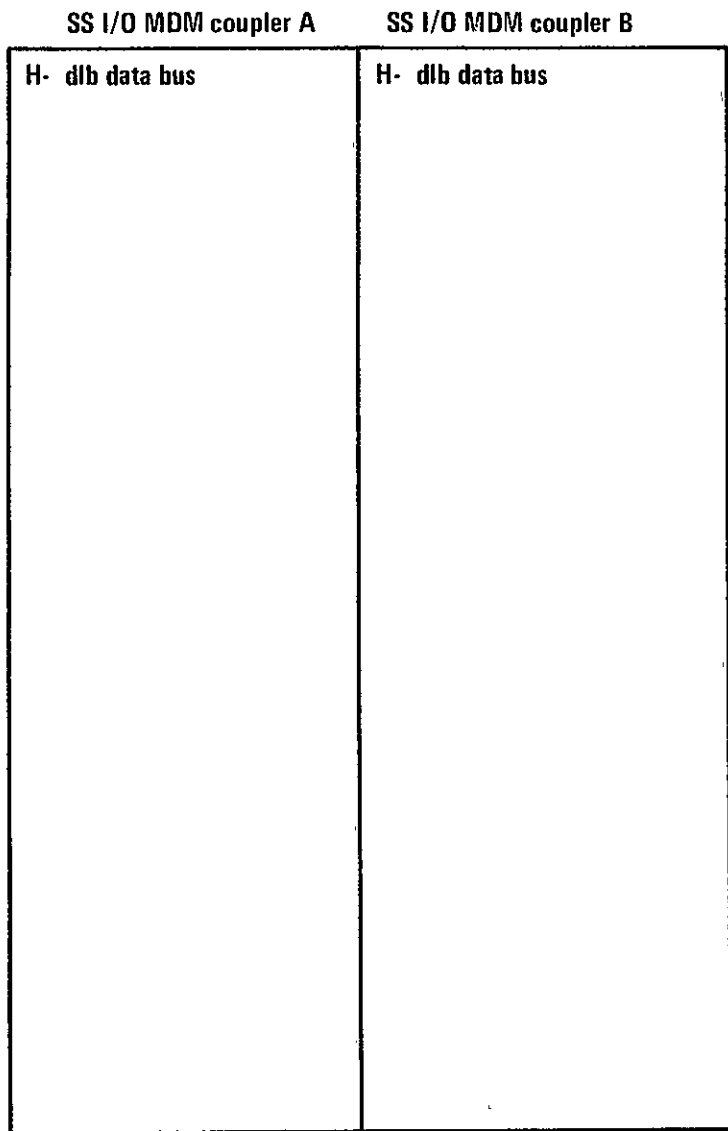

9,27

MDM PF1

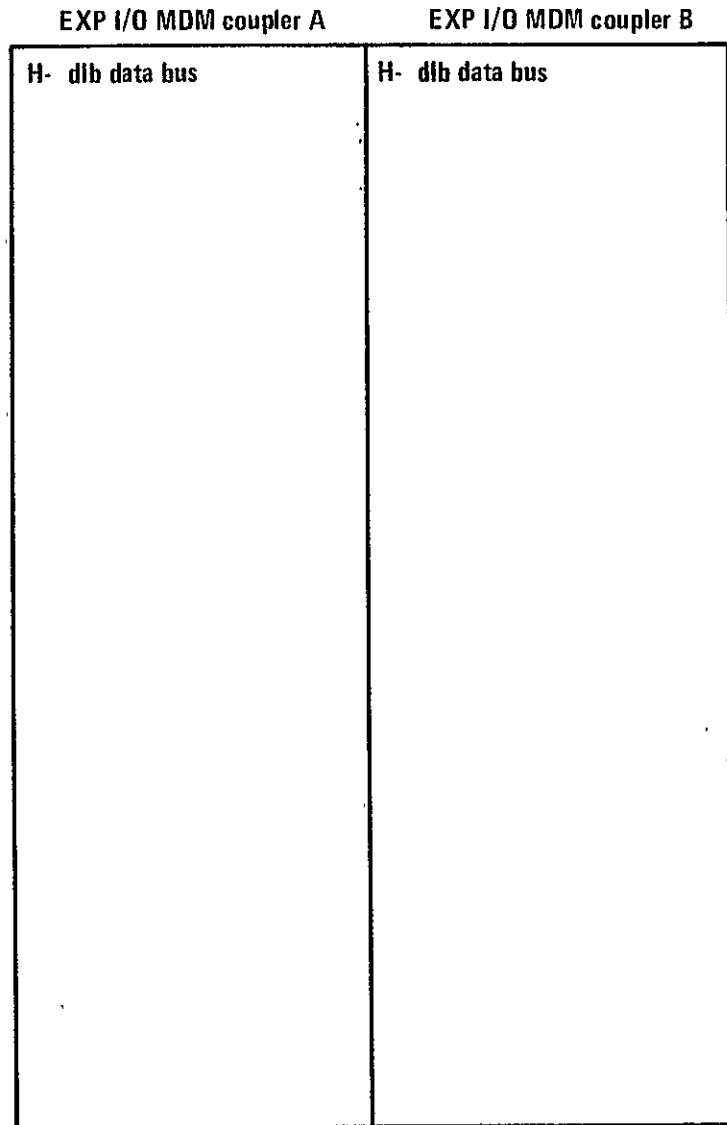

9,40

(j) 9,27 and 9,40.

Figure 4.- Continued.

MDM PF2

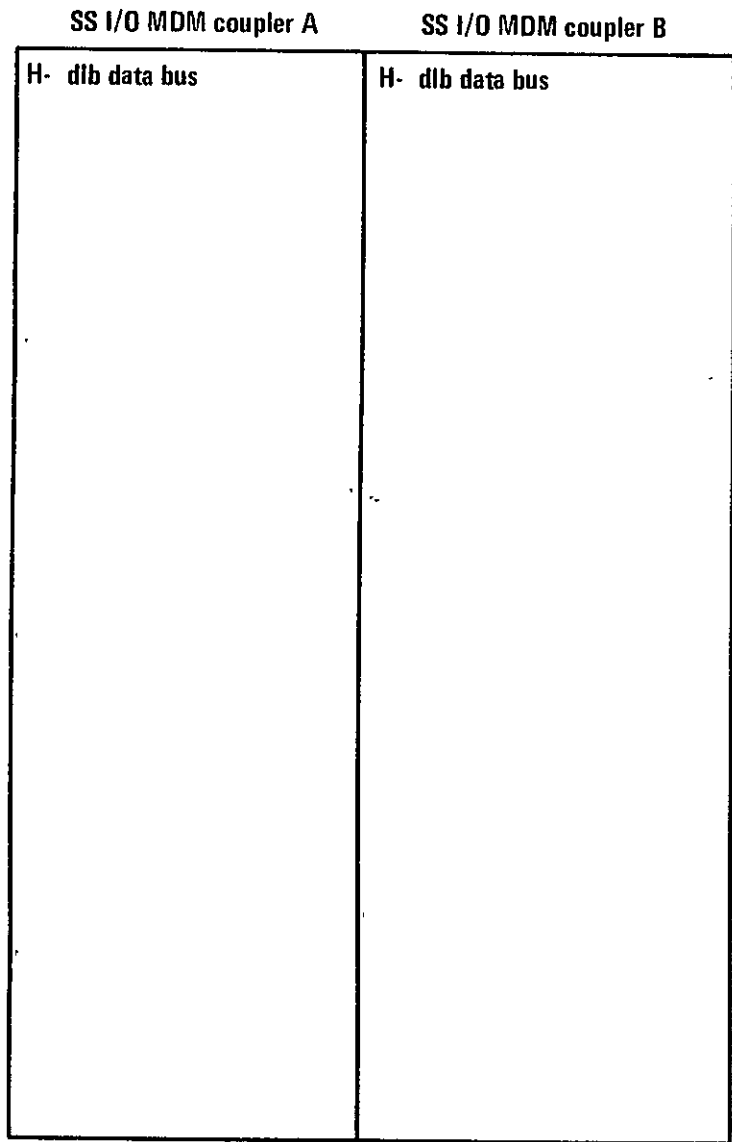

10,27

MDM PF2

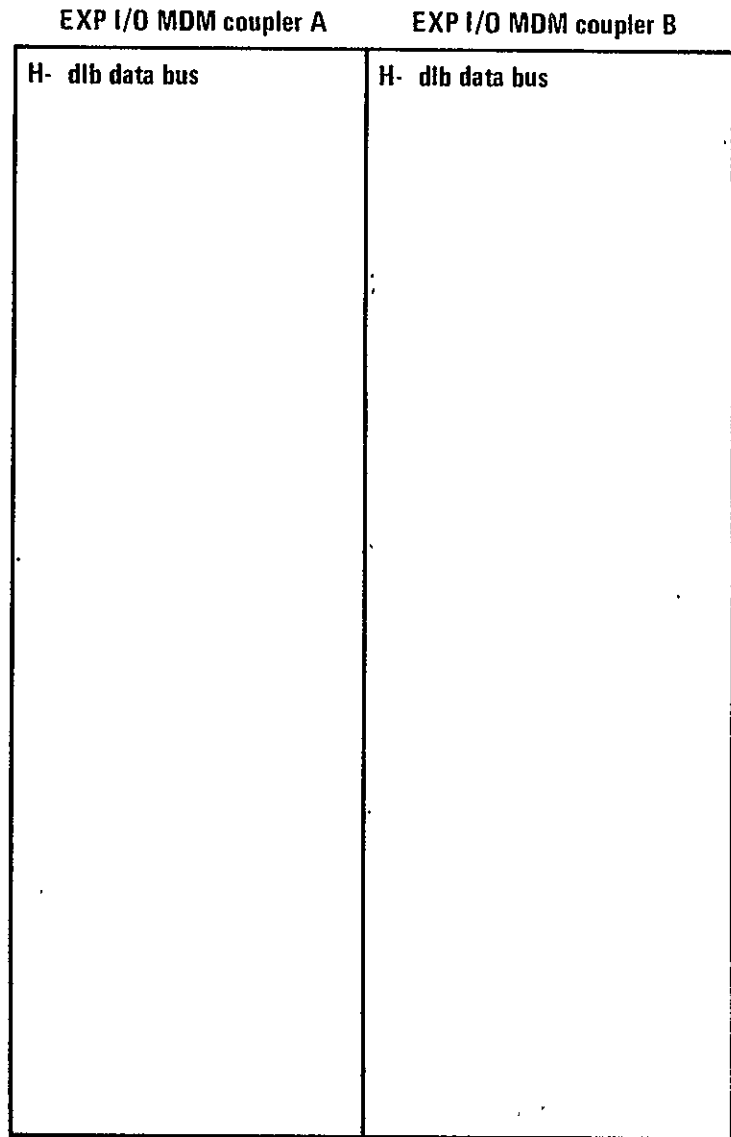

10,40

(k) 10,27 and 10,40.

Figure 4.- Continued.

RAAB

RAAB

11,11

MTU

11,19

M- RAAB 28V Bus 1 Voltage (0, 40) (C, B, B, B, B) (V, M, M, M, M)
RAAB 28V Bus 2 Voltage (0, 40) (C, B, B, B, B) (V, M, M, M, M)
RAAB 6V Bus 1 Voltage (0, 10) (C, B, B, B, B)
RAAB 6V Bus 2 Voltage (0, 10) (C, B, B, B, B)
RAAB +10V Bus Voltage (0, 15) (C, B, B, B, B)
RAAB -10V Bus Voltage (0, -15) (B, B, B, B, B)
RAAB 6V Bus 3 Voltage (0, 10) (C, B, B, B, B)
RAAB 6V Bus 4 Voltage (0, 10) (C, B, B, B, B)

RAAB MTU interface

H- dlb data bus

(1) 11,11 and 11,19.

Figure 4.- Continued.

RAAB MTU interface

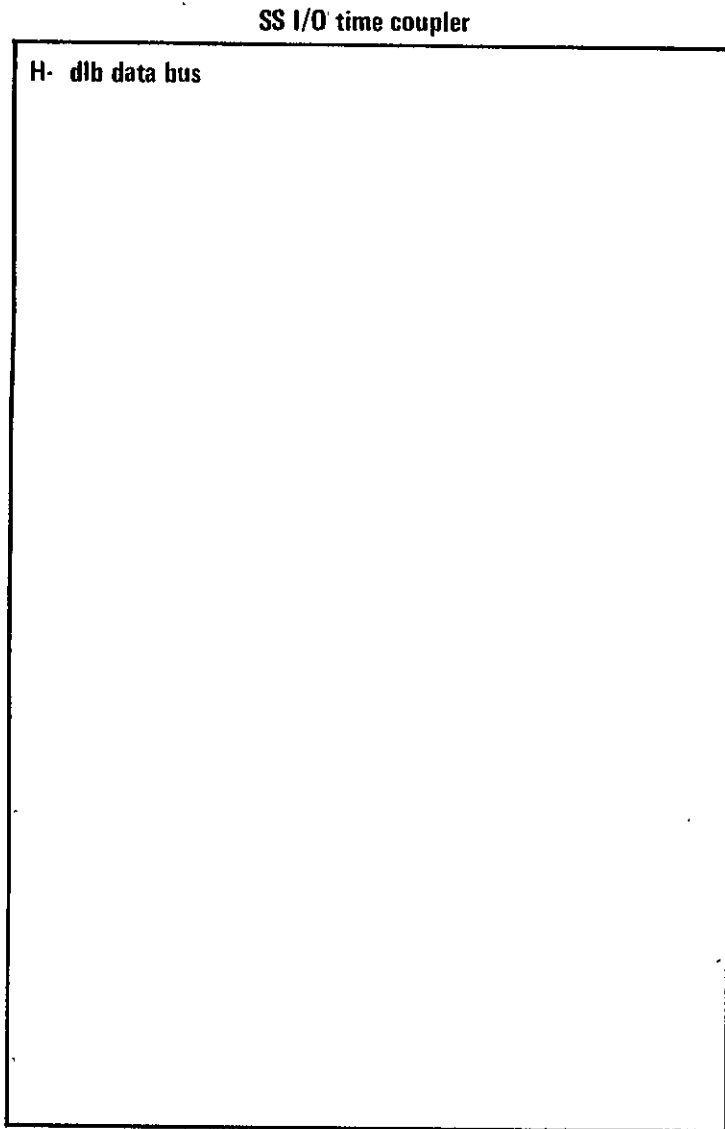

11,29

RAAB MTU interface

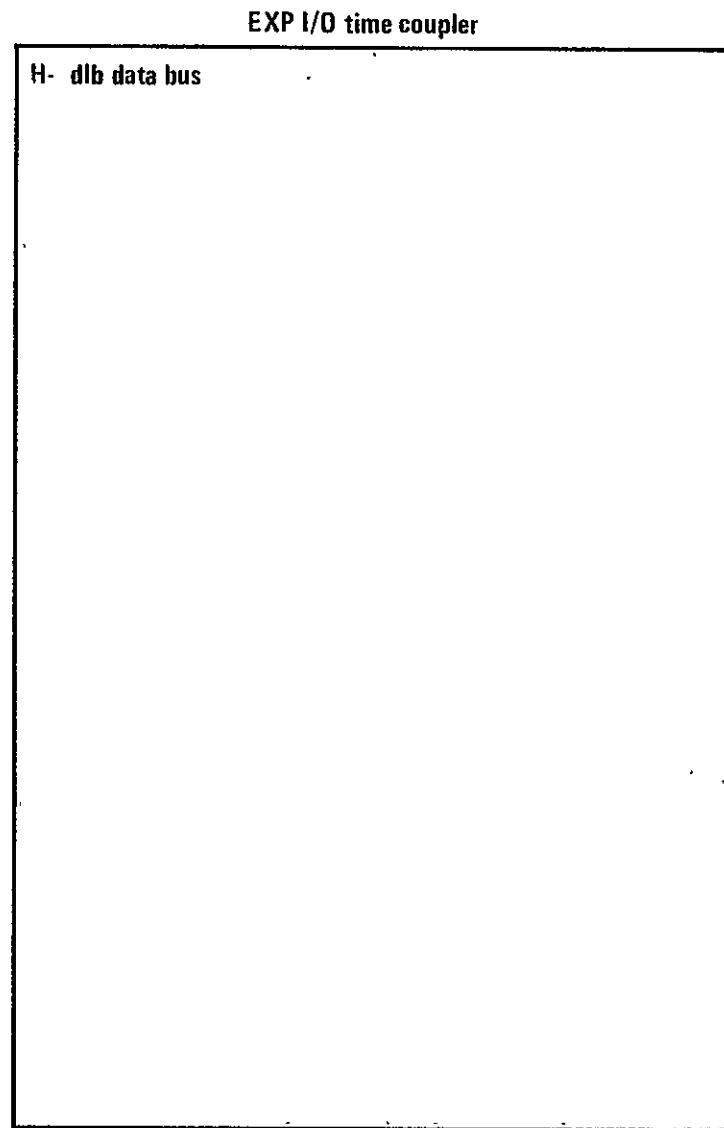

11,42

(m) 11,29 and 11,42.

Figure 4.- Continued.

	DDU1	DDU2	DDU3	12,12
DDU1	1,2,3,4,5,6 7,8,9,10,11, 12,13			
DDU2		1,2,3,4,5,6,7 8,9,10,11,12 13		
DDU3			1,2,3,4,5,6,7 8,9,10,11,12,13	

- 1) M- DDU_i PWR Supply Current (Amps) (C, A, A, A, A)
- 2) M- DDU_i BITE (NOGO, GO) (X, A, A, A, A)
- 3) M- DDU_i Phosphor Protection (NOGO, GO) (X, A, A, A, A)
- 4) M- DDU_i PWR Surge Over/Under Voltage (OVER, UNDER) (X, A, A, A, A)
- 5) M- DDU_i Secondary Voltage 1 (VDC) (C, A, A, A, A)
- 6) M- DDU_i Secondary Voltage 2 (VDC) (C, A, A, A, A)
- 7) M- DDU_i Secondary Voltage 3 (VDC) (C, A, A, A, A)
- 8) M- DDU_i Secondary Voltage 4 (VDC) (C, A, A, A, A)
- 9) M- DDU_i Secondary Voltage 5 (VDC) (C, A, A, A, A)
- 10) S- ON/OFF
- 11) S- DISPLAY DURATION
- 12) S- RESET/TEST
- 13) S- BRIGHTNESS

For relationships 1 to 9

$i = 1, 2, 3$

	KB1	KB2	KB3	12,13
DDU1	1 2	1 2	1 2	
DDU2	1 2	1 2	1 2	
DDU3	1 2	1 2	1 2	

- 1) C- KB_i to DDU_j
- 2) M- KB_i to DDU_j (CONN)

For relationships 1 and 2

$i = 1, 2, 3$

$j = 1, 2, 3$

(n) 12,12 and 12,13.

Figure 4.- Continued.

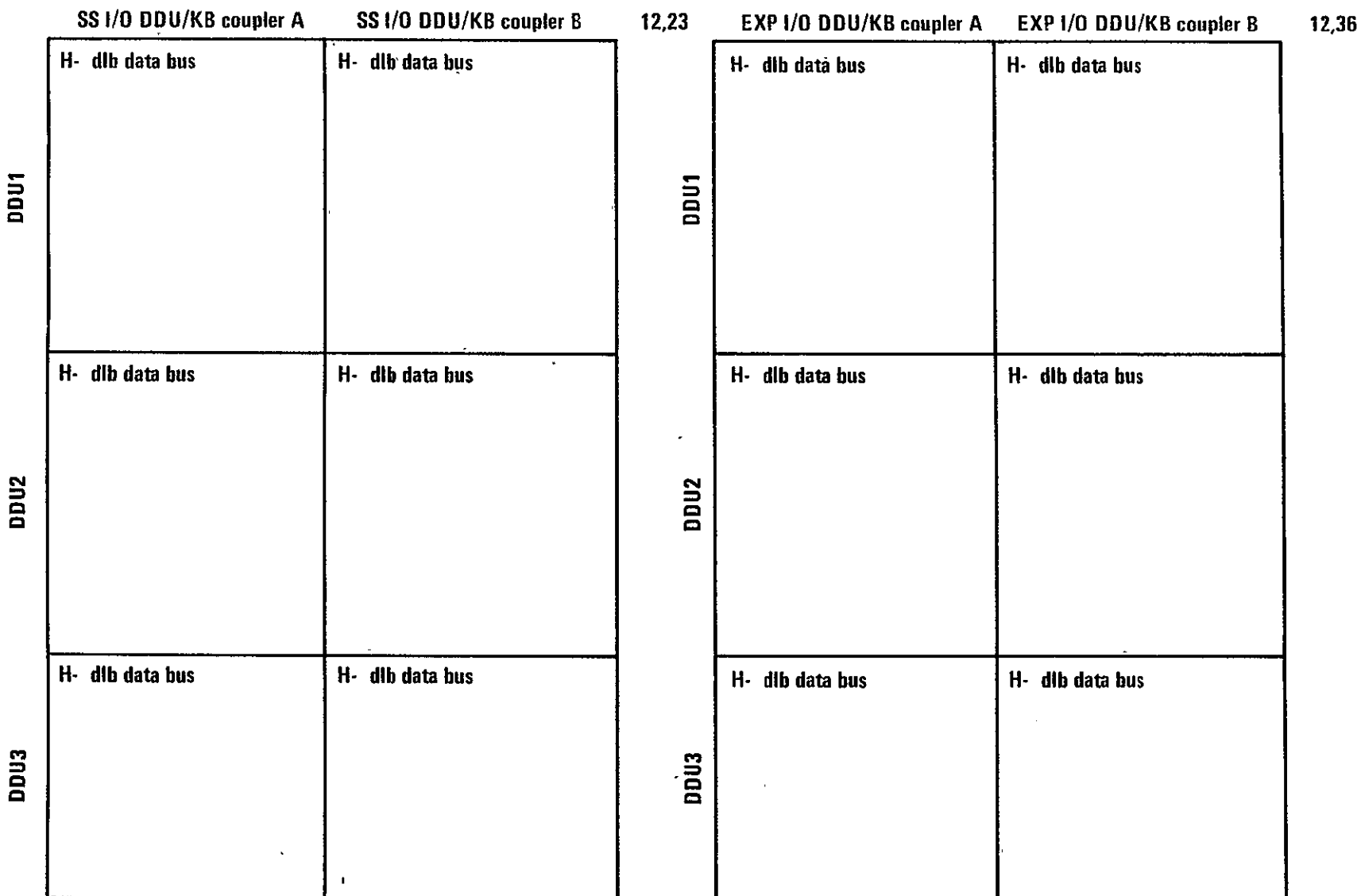

(o) 12,23 and 12,36.

Figure 4.- Continued.

	KB1	KB2	KB3
KB1	1,2,3,4,5,6		
KB2		1,2,3,4,5,6	
KB3			1,2,3,4,5,6

13,13

	SS I/O DDU/KB coupler A	SS I/O DDU/KB coupler B
KB1	H- dlb data bus	H- dlb data bus
KB2	H- dlb data bus	H- dlb data bus
KB3	H- dlb data bus	H- dlb data bus

13,23

- 1) M- KB_i PWR Supply Voltage (VAC) (C, A, A, A, A)
- 2) M- KB_i PWR Supply Current (Amps) (C, A, A, A, A)
- 3) M- KB_i BITE (NOGO, GO) (X, A, A, A, A)
- 4) M- KB_i PWR Surge Over/Under Voltage (OVER, UNDER)
(X, A, A, A, A)
- 5) S- ON/OFF
- 6) S- RESET

For relationships 1 to 4

i = 1, 2, 3

(p) :13,13 and 13,23.

Figure 4.- Continued.

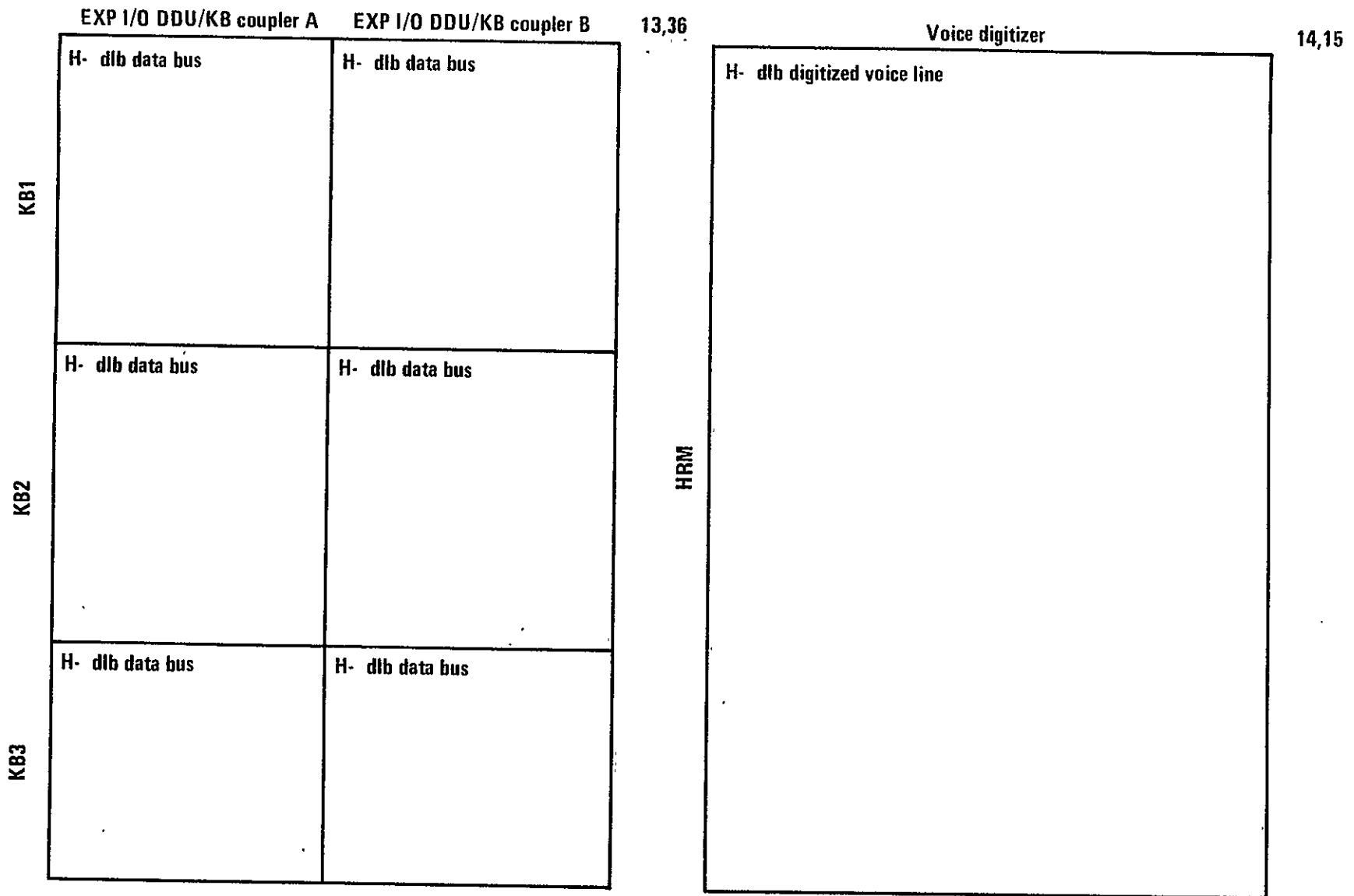

(q) 13,36 and 14,15.

Figure 4.- Continued.

HRM

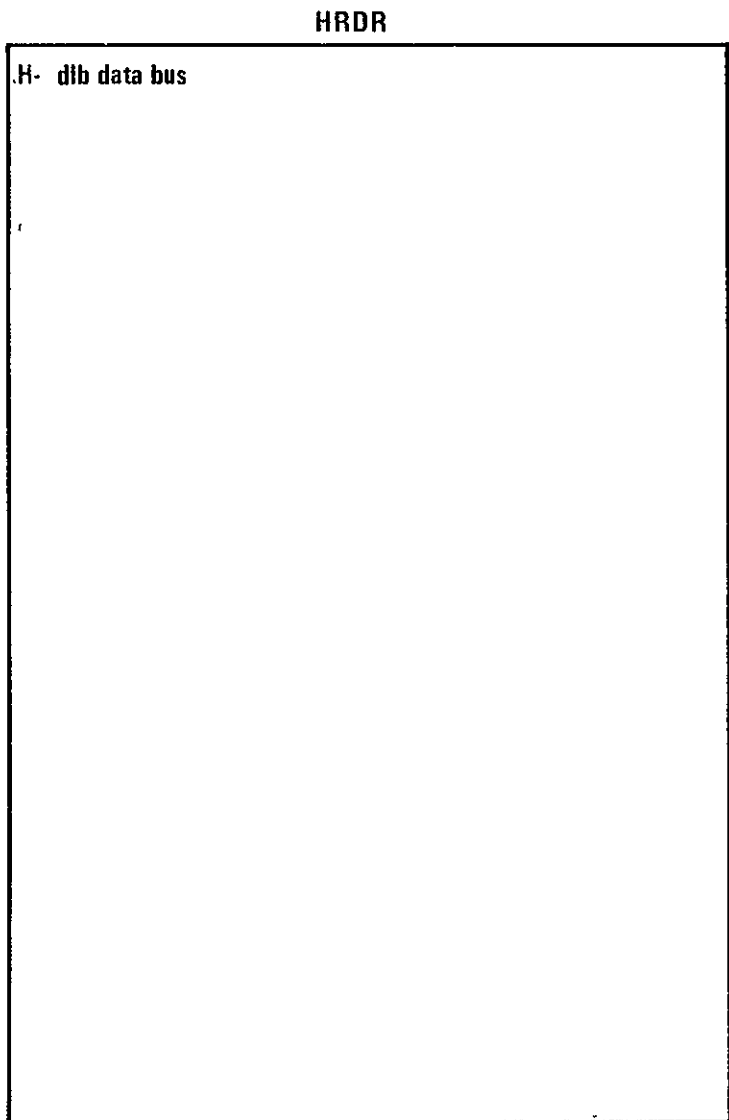

14,16

HRM

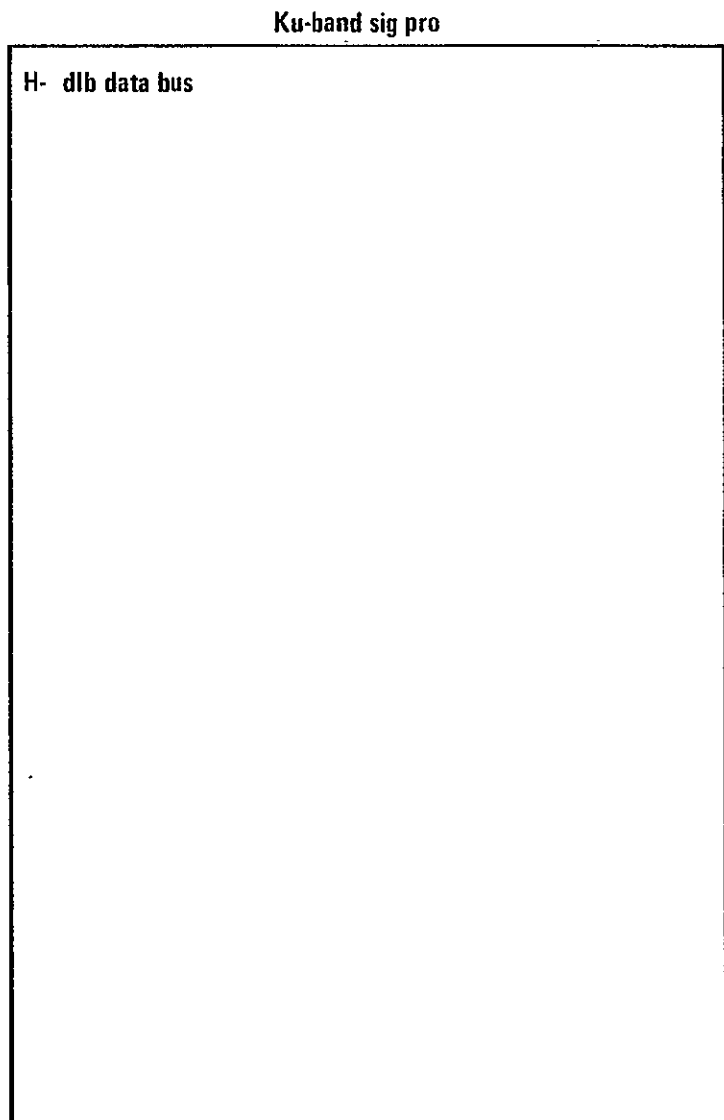

14,20

(r) 14,16 and 14,20.

Figure 4.- Continued.

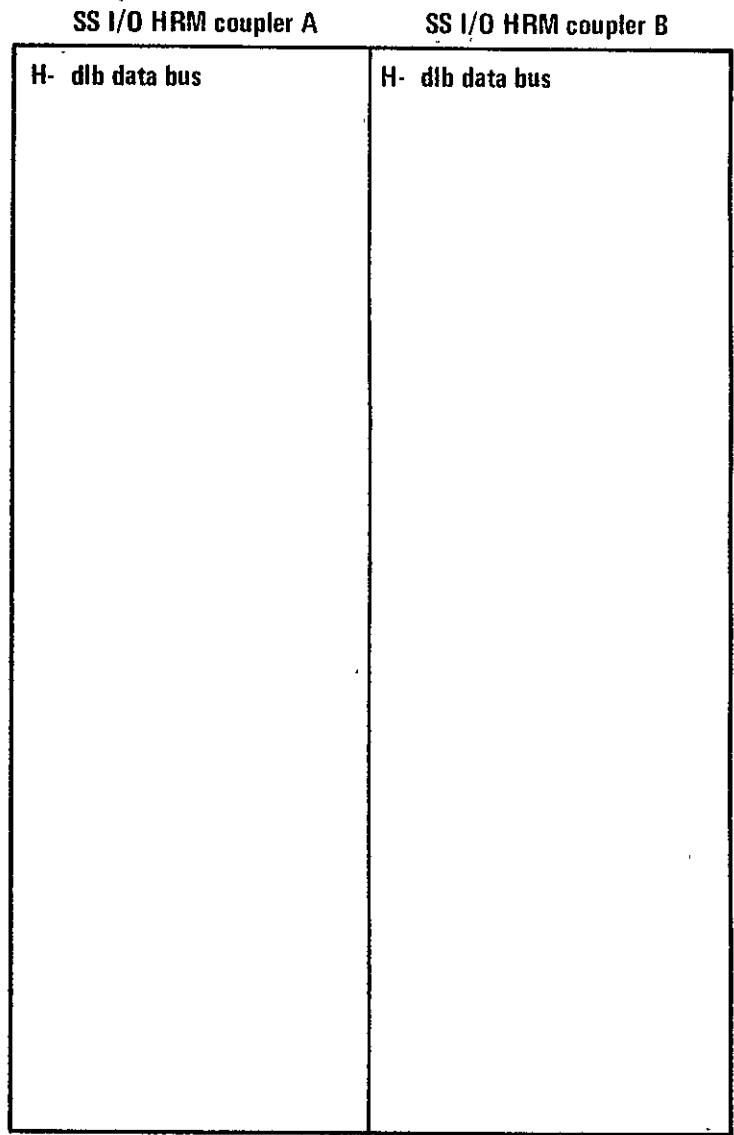
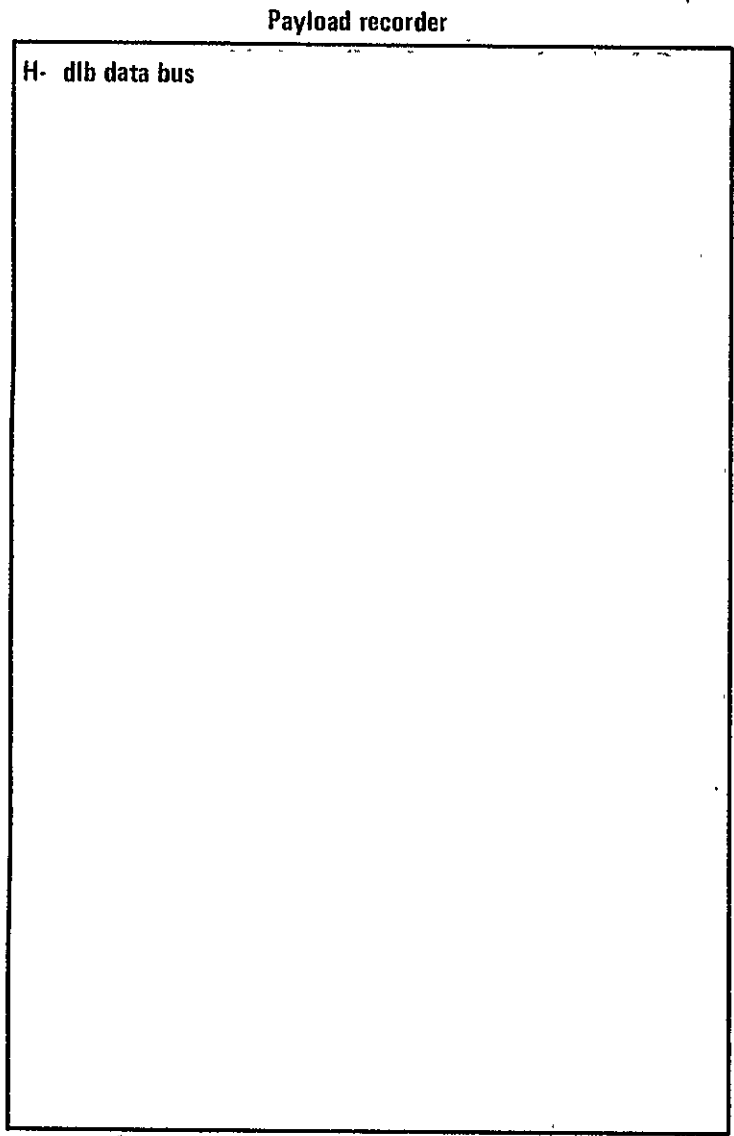

(s) 14,22 and 14,28.

Figure 4.- Continued.

71

HRM

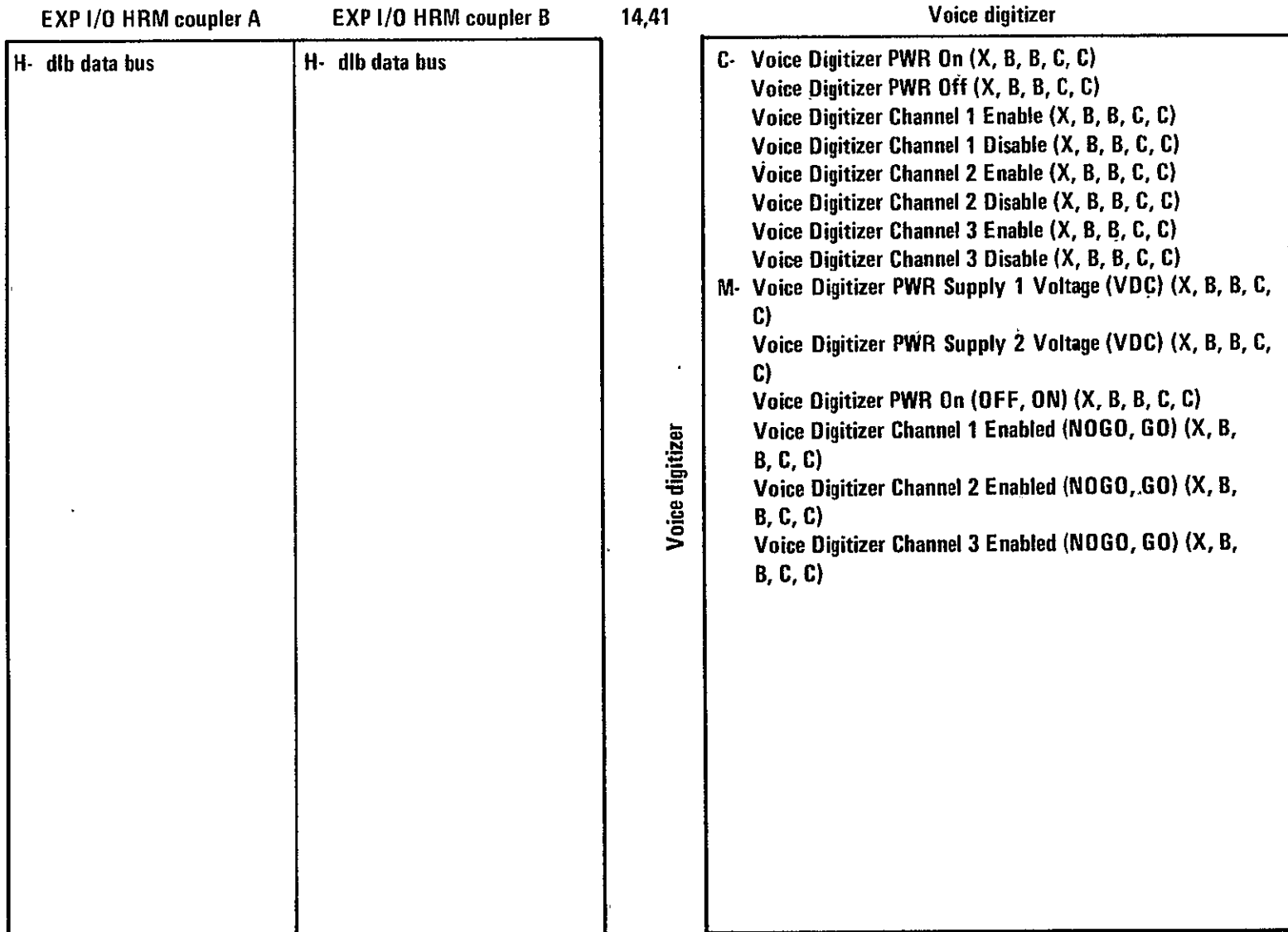

Voice digitizer

(t) 14,41 and 15,15.

Figure 4.- Continued.

Voice digitizer

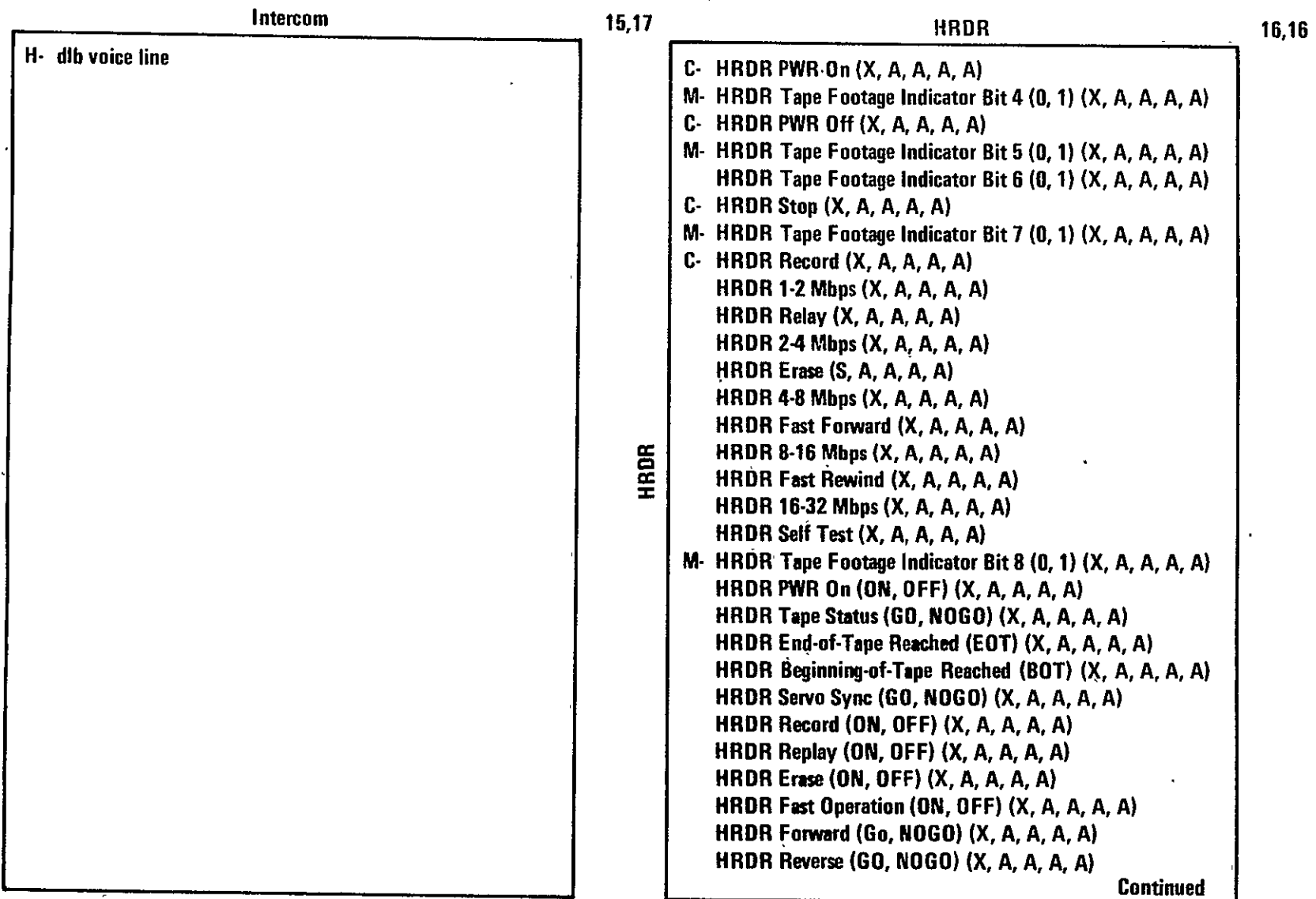

(u) 15,17 and 16,16.

Figure 4.- Continued.

HRDR

HRDR

M- HRDR Rate Selected 2 Mbps (ON, OFF) (X, A, A, A, A)
 HRDR Rate Selected 4 Mbps (On, OFF) (X, A, A, A, A)
 HRDR Rate Selected 8 Mbps (ON, OFF) (X, A, A, A, A)
 HRDR Rate Selected 16 Mbps (On, OFF) (X, A, A, A, A)
 HRDR Rate Selected 32 Mbps (ON, OFF) (X, A, A, A, A)
 HRDR EU BITE (NOGO, GO) (X, A, A, A, A)
 HRDR TU BITE (NOGO, GO) (X, A, A, A, A)
 HRDR Self Test Busy (BUSY) (X, A, A, A, A)
 HRDR Local Control Busy (BUSY) (X, A, A, A, A)
 HRDR PWR Supply Status (GO, NOGO) (X, A, A, A, A)
 HRDR Motor Current (Amps) (X, A, A, A, A)
 HRDR Internal TEMP (Deg C) (X, A, A, A, A)
 HRDR Secondary Voltage 1 (VDC) (X, A, A, A)
 HRDR Tape Footage Indicator Bit 1 (0, 1) (X, A, A, A, A)
 HRDR Tape Footage Indicator Bit 2 (0, 1) (X, A, A, A, A)
 HRDR Tape Footage Indicator Bit 3 (0, 1) (X, A, A, A, A)

Concluded

16,16

Intercom

Intercom

M- Intercom Master PWR Supply 1 Voltage (VDC) (X, B, B, -, -)
 Intercom Master PWR Supply 2 Voltage (VDC) (X, B, B, -, -)
 Intercom Master PWR Supply 3 Voltage (VDC) (X, B, B, -, -)
 Intercom Master PWR Supply 4 Voltage (VDC) (X, B, B, -, -)

17,17

(v) 16,16 and 17,17.

Figure 4.- Continued.

74

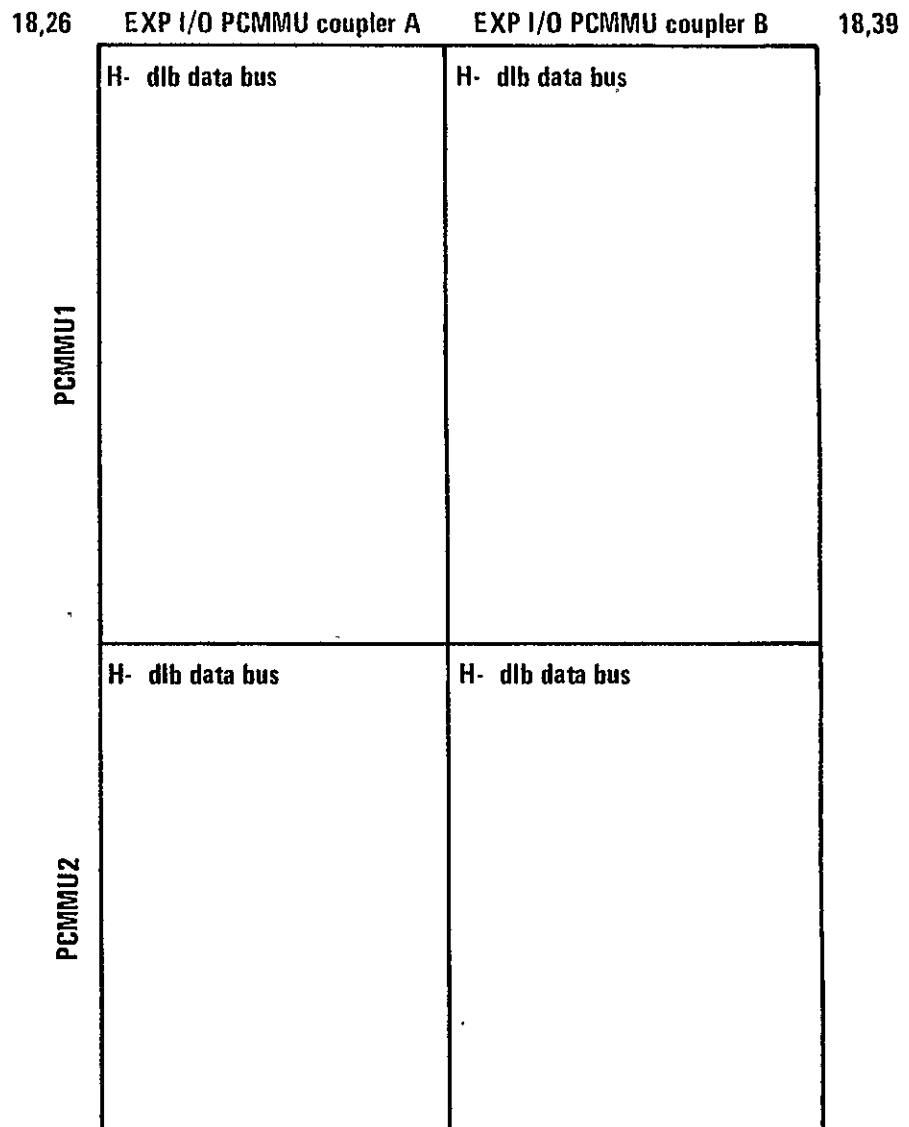
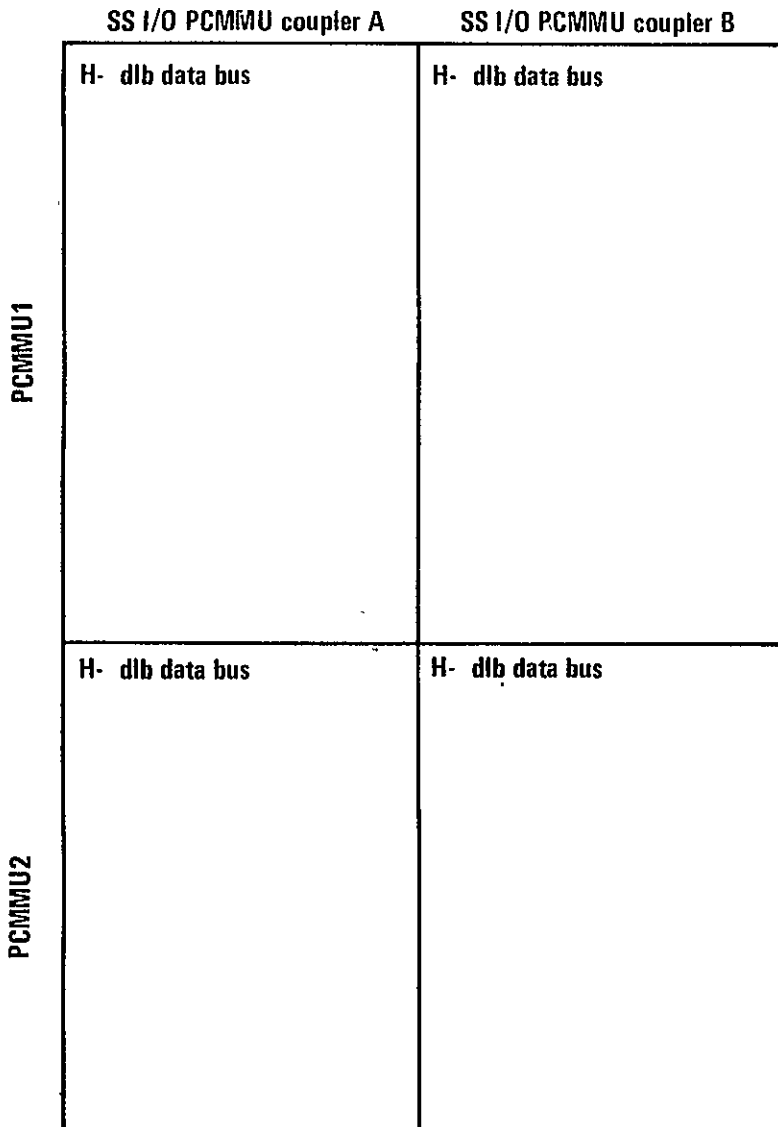

(w) 18,26 and 18,39.

Figure 4.- Continued.

Ku-band sig pro

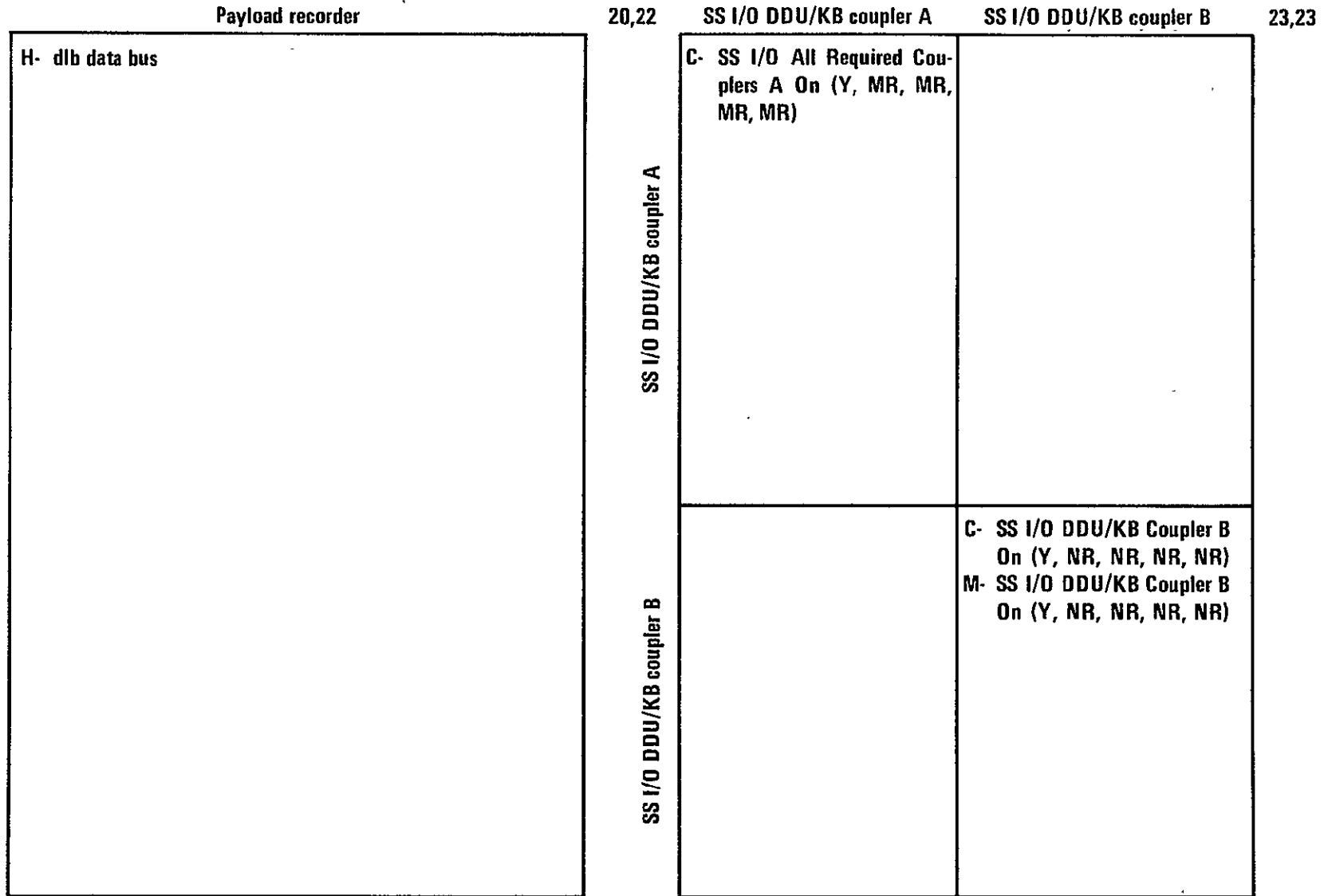

(x) 20,22 and 23,23.

Figure 4.- Continued.

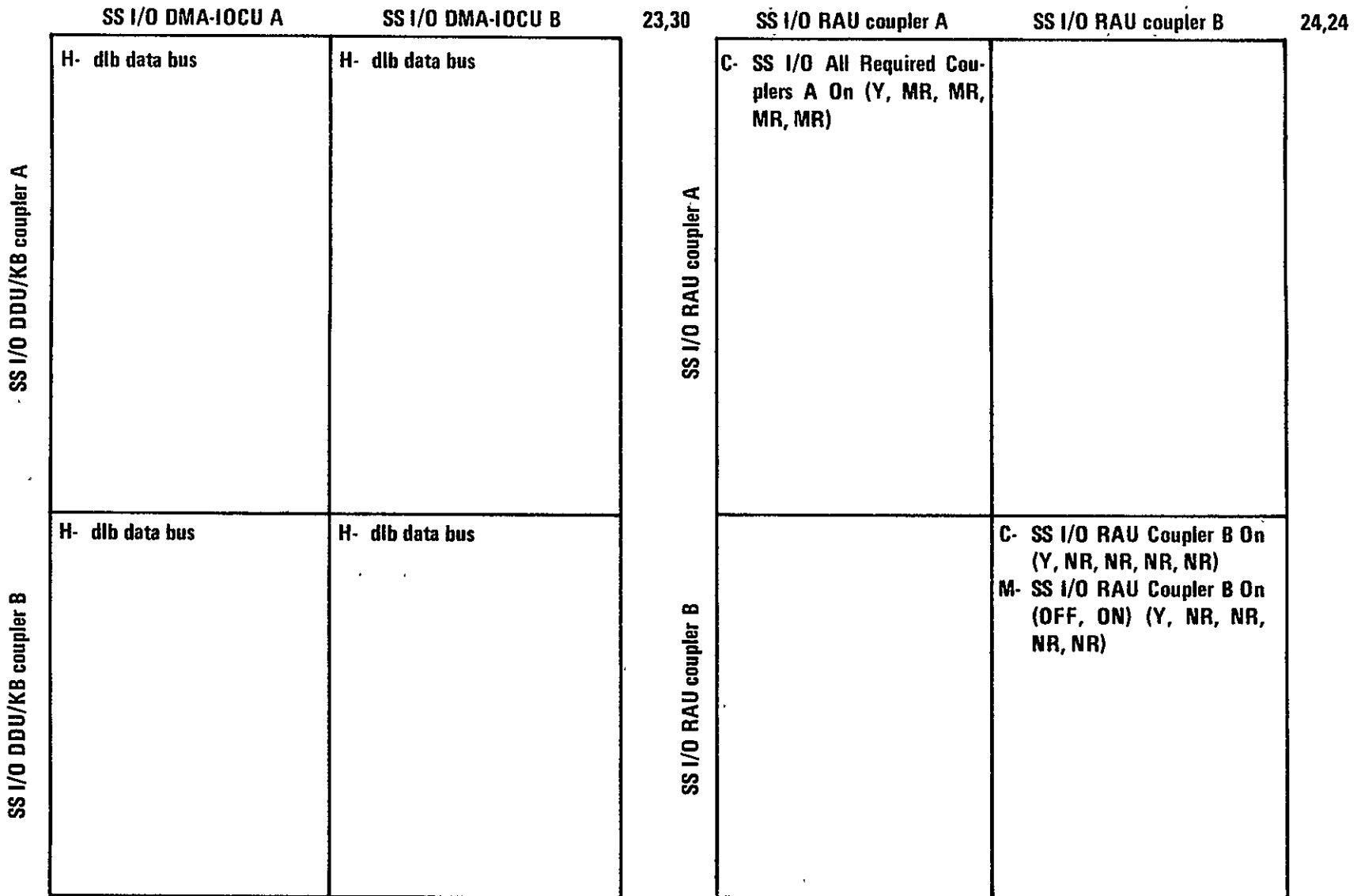

(y) 23,30 and 24,24.

Figure 4.- Continued.

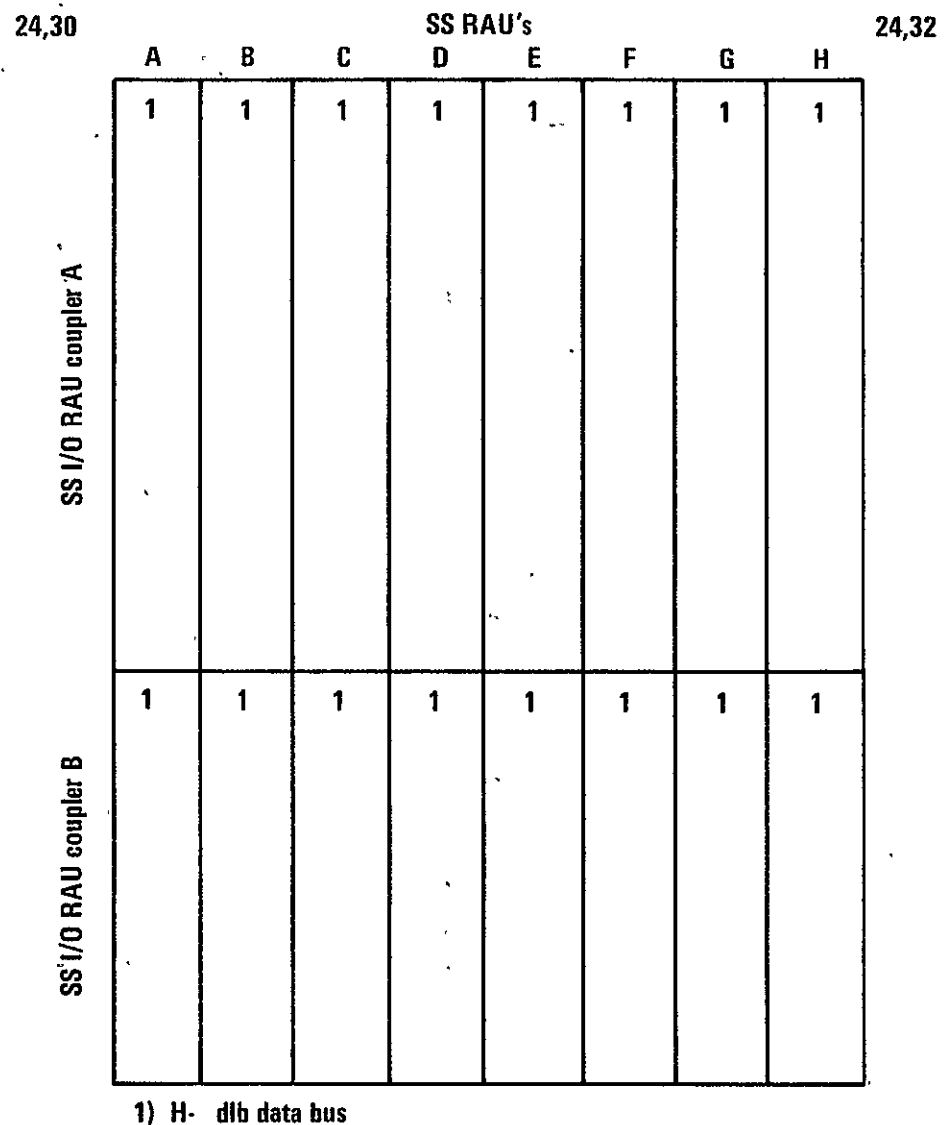
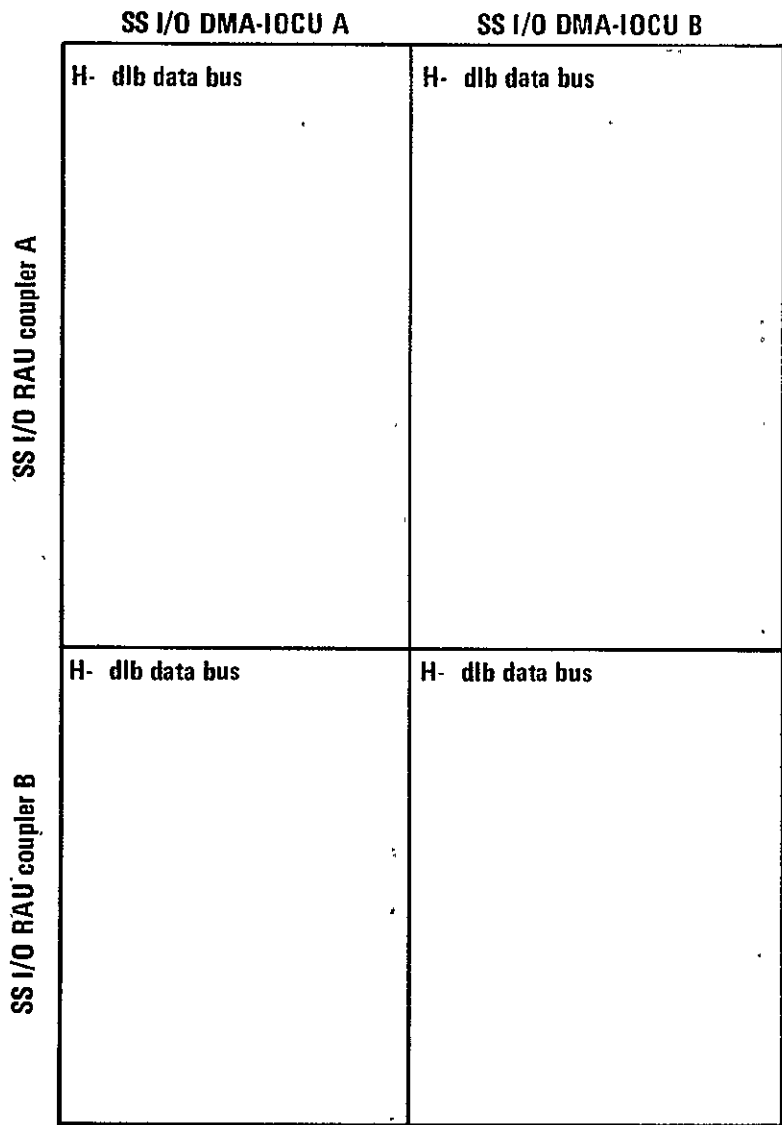

(z) 24,30 and 24,32.

Figure 4.- Continued.

	SS I/O MMU coupler A	SS I/O MMU coupler B	25,25
SS I/O MMU coupler A	C- SS I/O Required Couplers A On (Y, MR, MR, MR, MR) M- SS I/O Coupler BITE (NO- GO, GO) (Y, MR, MR, MR, MR)		
SS I/O MMU coupler B		C- SS I/O MMU Coupler B On (Y, NR, NR, NR, NR) M- SS I/O MMU Coupler B On (OFF, ON) (Y, NR, NR, NR, NR) SS I/O MMU Coupler BITE (NOGO, GO) (Y, MR, MR, MR, MR)	

	SS I/O DMA-IOCU A	SS I/O DMA-IOCU B	25,30
SS I/O MMU coupler A	H- dlb data bus	H- dlb data bus	
SS I/O MMU coupler B	H- dlb data bus	H- dlb data bus	

(a') 25,25 and 25,30.
 Figure 4.- Continued.

		SS I/O PCMMU coupler A	SS I/O PCMMU coupler B	26,26	SS I/O DMA-IOCU A	SS I/O DMA-IOCU B	26,30
SS I/O PCMMU coupler A	C-	SS I/O All Required Couplers A On (Y, MR, MR, MR, MR)			H-	dlb data bus	
	M-	SS I/O PCMMU Coupler BITE (NOGO, GO) (Y, MR, MR, MR, MR)			H-	dlb data bus	
SS I/O PCMMU coupler B	C-	SS I/O PCMMU Coupler B On (Y, NR, NR, NR, NR)			H-	dlb data bus	
	M-	SS I/O PCMMU Coupler BITE (NOGO, GO) (Y, MR, MR, MR, MR) SS I/O PCMMU Coupler B On (OFF, ON) (Y, NR, NR, NR, NR)			H-	dlb data bus	
					SS I/O PCMMU coupler A		
					SS I/O PCMMU coupler B		

b') 26,26 and 26,30.

Figure 4. - Continued.

		SS I/O MDM coupler A	SS I/O MDM coupler B	27,27	SS I/O DMA-IOCU A	SS I/O DMA-IOCU B	27,30
SS I/O MDM coupler A	C-	SS I/O All Required couplers A On (Y, MR, MR, MR, MR)		SS I/O MDM coupler A	H- dlb data bus		
	M-	SS I/O MDM coupler BITE (NOGO, GO) (Y, MR, MR, MR, MR)			H- dlb data bus		
SS I/O MDM coupler B	C-	SS I/O MDM Coupler B On (Y, NR, NR, NR, NR)		SS I/O MDM coupler B	H- dlb data bus		
	M-	SS I/O MDM Coupler BITE (NOGO, GO) (Y, MR, MR, MR, MR) SS I/O MDM Coupler B On (OFF, ON) (Y, NR, NR, NR, NR)			H- dlb data bus		

(c') 27,27 and 27,30.

Figure 4.- Continued.

	SS I/O HRM coupler A	SS I/O HRM coupler B	28,28	SS I/O DMA-IOCU A	SS I/O DMA-IOCU B	28,30
SS I/O HRM coupler A	C- SS I/O All Required Couplers A On (Y, MR, MR, MR, MR)		SS I/O HRM coupler A	H- dlb data bus	H- dlb data bus	
SS I/O HRM coupler B		C- SS I/O HRM Coupler B On (Y, NR, NR, NR, NR) (this command is only a possible command) M- SS I/O HRM Coupler B On (OFF, ON) (Y, NR, NR, NR, NR) (this measurement is only a possible measurement)	SS I/O HRM coupler B	H- dlb data bus	H- dlb data bus	

(d') 28,28 and 28,30.

Figure 4.- Continued..

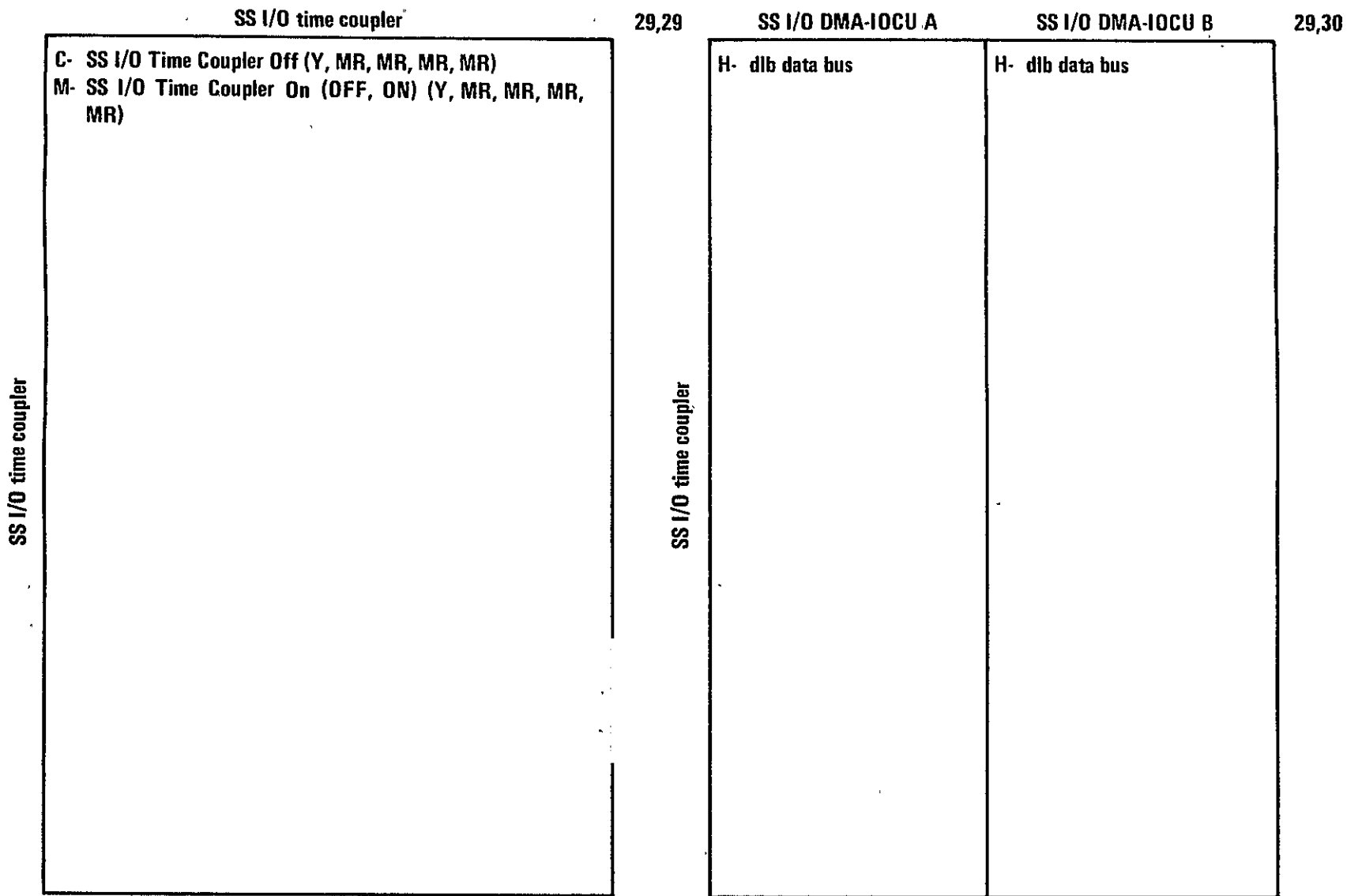

(e') 29,29 and 29,30.

Figure 4.- Continued.

C-2

88

	SS I/O DMA-IOCU A	SS I/O DMA-IOCU B	30,30.	SS COMP CPU	30,45
SS I/O DMA-IOCU A	<p>C- SS I/O PWR On/DMA to SS COMP (Y, MR, MR, MR, MR) (turn power on)</p> <p>M- SS I/O PWR A On (OFF, ON) (Y, MR, MR, MR, MR)</p> <p>SS I/O DMA-IOCU Coupler BITE (NOGO, GO) (Y, MR, MR, MR, MR)</p>				
SS I/O DMA-IOCU B		<p>C- SS I/O PWR B On (Y, NR, NR, NR, NR)</p> <p>SS I/O PWR A and B Off (Y, MR, MR, MR, MR)</p> <p>M- SS I/O PWR B On (OFF, ON) (Y, NR, NR, NR, NR)</p> <p>SS I/O DMA-IOCU Coupler BITE (NOGO, GO) (Y, MR, MR, MR, MR)</p>			
			SS I/O DMA-IOCU A	<p>C- SS COMP PWR On/SS DMA to SS COMP (Y, MR, MR, MR, MR)</p> <p>(opens hardware link between SS I/O DMA-IOCU A and SS COMP CPU)</p> <p>SS COMP PWR Off/ AUTO RESTART Off (Y, MR, MR, MR, MR)</p> <p>(closes hardware link between SS I/O DMA-IOCU A and SS COMP CPU)</p> <p>SS I/O PWR A and B Off (Y, MR, MR, MR, MR)</p> <p>(closes hardware link between SS I/O DMA-IOCU A and SS COMP CPU)</p> <p>SS I/O PWR A On/DMA to SS COMP (Y, MR, MR, MR, MR)</p> <p>(opens hardware link between SS I/O DMA-IOCU A and SS COMP CPU)</p> <p>M- SS I/O DMA-IOCU to SS COMP (CONN) (Y, NR, NR, NR, NR)</p> <p>H- dlb data bus</p>	

(f') 30,30 and 30,45.

Figure 4.- Continued.

SS I/O DMA-IOCU B

BU COMP CPU

- M- SS I/O DMA-IOCU to BU COMP (CONN) (Y, NR, NR, NR, NR)
- C- BU COMP PWR On/SS DMA to BU COMP (Y, NR, NR, NR, NR)
 (opens hardware link between SS I/O DMA-IOCU B and BU COMP CPU)
 BU COMP PWR Off/AUTO RESTART Off (Y, MR, MR, MR, MR)
 (closes hardware link between SS I/O DMA-IOCU B and BU COMP CPU)
 SS I/O PWR A and B Off (Y, MR, MR, MR, MR)
 (closes hardware link between SS I/O DMA-IOCU B and BU COMP CPU)
- H- dlb data bus

30,47

SS RAU's

32,32

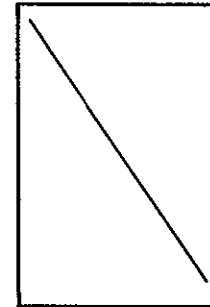

All entries are on the principal diagonal.

- RAU A 1, 2, 3, 5
- RAU B 1, 2, 3, 5
- RAU C 1, 2, 3, 5
- RAU D 1, 2, 3, 5
- RAU E 1, 2, 3, 5
- RAU F 1, 2, 3, 5
- RAU G 1, 2, 4, 6
- RAU H 1, 2, 4, 6

- 1) C- All SS RAU's On (Y, MR, MR, MR, MR)
- 2) C- All SS RAU's Off (Y, MR, MR, MR, MR)
- 3) C- SS RAU_i On (Y, NR, NR, NR, NR)
- 4) C- SS RAU_i On (Y, NR, -, NR, -)
- 5) M- SS RAU_i On (OFF, ON) (Y, MR, MR, MR, MR)
- 6) M- SS RAU_i On (OFF, ON) (Y, MR, -, MR, -)

For relationships 3 and 5

For relationships 4 and 6

i = A, B, C, D, E, F

i = G, H

(g') 30,47 and 32,32.

Figure 4.- Continued.

EXP RAU top airlock

EXP RAU top airlock

33,33

EXP I/O RAU coupler A

EXP I/O RAU coupler B

33,37

C- EXP RAU Top Airlock On (X, -, D, -, -)
 EXP RAU Top Airlock Off (X, -, D, -, -)
 All EXP RAU's On (X, DR, DR, CR, CR)
 M- EXP RAU Top Airlock On (OFF, ON) (X, -, B, -, -)

EXP top airlock RAU

H- dlb data bus

H- dlb data bus

(h') 33,33 and 33,37.

Figure 4.- Continued.

RAU's - EXP racks

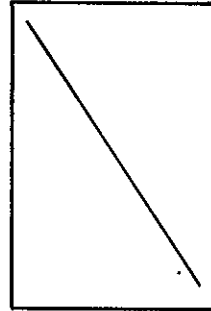

All entries are on the principal diagonal.

- Rack 2 1, 2, 5, 6
- Rack 3 1, 2, 5, 6
- Rack 5 1, 2, 5, 6
- Rack 6 1, 2, 5, 6
- Rack 7 3, 4, 5, 7
- Rack 8 3, 4, 5, 7
- Rack 9 3, 4, 5, 7
- Rack 10 3, 4, 5, 7
- Rack 11 3, 4, 5, 7
- Rack 12 3, 4, 5, 7

- 1) C- RAU - EXP Rack ; On (X, E, E, -, -)
- 2) C- RAU - EXP Rack ; Off (X, E, E, -, -)
- 3) C- RAU - EXP Rack ; On (X, -, F, -, -)
- 4) C- RAU - EXP Rack ; Off (X, -, F, -, -)
- 5) C- All EXP RAU's On (X, DR, DR, CR, CR)
- 6) M- RAU - EXP Rack ; On (OFF, ON) (X, E, E, -, -)
- 7) M- RAU - EXP Rack ; On (OFF, ON) (X, -, F, -, -)

For relationships 1, 2, and 6

i = 2, 3, 5, 6

For relationships 3, 4, and 7

i = 7, 8, 9, 10, 11, 12

34,34

EXP I/O RAU coupler A

EXP I/O RAU coupler B

34,37

EXP rack RAU's

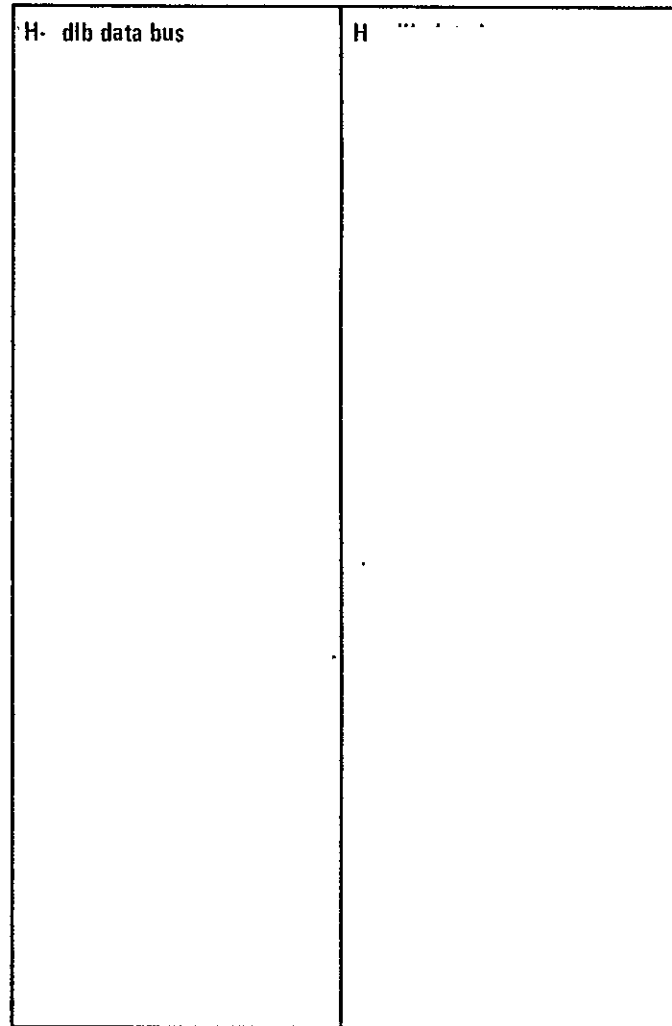

(i') 34,34 and 34,37.

Figure 4.- Continued..

RAU's - EXP pallets

35,35

35,35

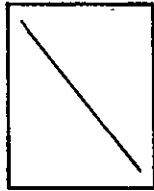

All entries are on the principal diagonal.

EXP	Pallet	
1	1	1, 2, 3, 12
2	1	1, 2, 3, 12
3	1	1, 2, 3, 12
4	1	1, 2, 3, 12
1	2	1, 4, 5, 13
2	2	1, 4, 5, 13
3	2	1, 4, 5, 13
4	2	1, 4, 5, 13
1	3	1, 6, 7, 14
2	3	1, 6, 7, 14
3	3	1, 6, 7, 14
4	3	1, 6, 7, 14
1	4	1, 8, 9, 15
2	4	1, 8, 9, 15
3	4	1, 8, 9, 15
4	4	1, 8, 9, 15
1	5	1, 10, 11, 16
2	5	1, 10, 11, 16
3	5	1, 10, 11, 16
4	5	1, 10, 11, 16

Continued

- 1) C- All EXP RAU's On (X, DR, DR, CR, CR)
- 2) C- RAU- EXP_i; Pallet 1 On (X, F, -, D, D)
- 3) C- RAU- EXP_i; Pallet 1 Off (X, F, -, D, D)
- 4) C- RAU- EXP_i; Pallet 2 On (X, G, -, E, E)
- 5) C- RAU- EXP_i; Pallet 2 Off (X, G, -, E, E)
- 6) C- RAU- EXP_i; Pallet 3 On (X, H, -, F, F)
- 7) C- RAU- EXP_i; Pallet 3 Off (X, H, -, F, F)
- 8) C- RAU- EXP_i; Pallet 4 On (X, -, -, G, -)
- 9) C- RAU- EXP_i; Pallet 4 Off (X, -, -, G, -)
- 10) C- RAU- EXP_i; Pallet 5 On (X, -, -, H, -)
- 11) C- RAU- EXP_i; Pallet 5 Off (X, -, -, H, -)
- 12) M- RAU- EXP_i; Pallet 1 On (OFF, ON) (X, F, -, D, D)
- 13) M- RAU- EXP_i; Pallet 2 On (OFF, ON) (X, G, -, E, E)
- 14) M- RAU- EXP_i; Pallet 3 On (OFF, ON) (X, H, -, F, F)
- 15) M- RAU- EXP_i; Pallet 4 On (OFF, ON) (X, -, -, G, -)
- 16) M- RAU- EXP_i; Pallet 5 On (OFF, ON) (X, -, -, H, -)

Concluded

For relationships 2 to 16 :

$$i = 1, 2, 3, 4$$

(j') 35,35.

Figure 4.- Continued.

EXP pallet RAU's

EXP I/O RAU coupler A	EXP I/O RAU coupler B	35,37	EXP I/O DDU/KB coupler A	EXP I/O DDU/KB coupler B	36,36
H- dlb data bus	H- dlb data bus	EXP I/O DDU/KB coupler A	C- EXP I/O All Required Couplers A On (X, DR, DR, DR, DR)		
			EXP I/O DDU/KB coupler B		C- EXP I/O DDU/KB Coupler B On (X, CR, CR, BR, BR) M- EXP I/O DDU/KB Coupler B On (OFF, ON) (X, CR, CR, BR, BR)

(k') 35,37 and 36,36.

Figure 4.- Continued.

EXP I/O DDU/KB coupler A	EXP I/O DMA-IOCU A	EXP I/O DMA-IOCU B	36,43	EXP I/O RAU coupler A	EXP I/O RAU coupler B	37,37
	H- dlb data bus	H- dlb data bus		C- EXP I/O All Required Couplers A On (X, DR, DR, CR, CR)		
EXP I/O DDU/KB coupler B	H- dlb data bus	H- dlb data bus		EXP I/O RAU coupler B	C- EXP I/O RAU Coupler B On (X, CR, CR, BR, BR) M- EXP I/O RAU Coupler B On (OFF, ON) (X, CR, CR, BR, BR)	

(1') 36,43 and 37,37.

Figure 4.- Continued.

		EXP I/O DMA-IOCU A	EXP I/O DMA-IOCU B	37,43	EXP I/O MMU coupler A	EXP I/O MMU coupler B	38,38
EXP I/O RAU coupler A		H- dlb data bus	H- dlb data bus	EXP I/O MMU coupler A	C- EXP I/O All Required Couplers A On (X, DR, DR, CR, CR) M- EXP I/O MMU Coupler BITE (GO, NOGO) (X, DR, DR, CR, CR)		
		H- dlb data bus	H- dlb data bus			EXP I/O MMU coupler B	C- EXP I/O MMU Coupler B On (X, CR, CR, BR, BR) M- EXP I/O MMU Coupler BITE (GO, NOGO) (X, DR, DR, CR, CR) EXP I/O MMU Coupler B On (OFF, ON) (X, CR, CR, BR, BR)

(m') 37,43 and 38,38.

Figure 4.- Continued.

EXP I/O DMA-IOCU A		EXP I/O DMA-IOCU B		38,43	EXP I/O PCMMU coupler A	EXP I/O PCMMU coupler B	39,39
EXP I/O MMU coupler A	H- dlb data bus	H- dlb data bus			EXP I/O PCMMU coupler A		
	H- dlb data bus	H- dlb data bus					
EXP I/O MMU coupler B	H- dlb data bus	H- dlb data bus			EXP I/O PCMMU coupler B		C- EXP I/O All Required Couplers A On (X, DR, DR, CR, CR) M- EXP I/O PCMMU Coupler BITE (GO, NOGO) (X, DR, DR, CR, CR)
	H- dlb data bus	H- dlb data bus					

(n') 38,43 and 39,39.

Figure 4.- Continued.

		EXP I/O DMA-IOCU A	EXP I/O DMA-IOCU B	39,43	EXP I/O MDM coupler A	EXP I/O MDM coupler B	40,40
EXP I/O PCMMU coupler A	H- dlb data bus	H- dlb data bus			C- EXP I/O All Required Couplers A On (X, DR, DR, CR, CR) M- EXP I/O MDM Coupler BITE (GO, NOGO) (X, DR, DR, CR, CR)		
	H- dlb data bus	H- dlb data bus				C- EXP I/O MDM Coupler B On (X, CR, CR, DR, DR) M- EXP I/O MDM Coupler BITE (GO, NOGO) (X, DR, DR, CR, CR) EXP I/O MDM Coupler B On (OFF, ON) (X, CR, CR, BR, BR)	
EXP I/O PCMMU coupler B	H- dlb data bus	H- dlb data bus					
	H- dlb data bus	H- dlb data bus					

(o') 39,43 and 40,40.

Figure 4.- Continued.

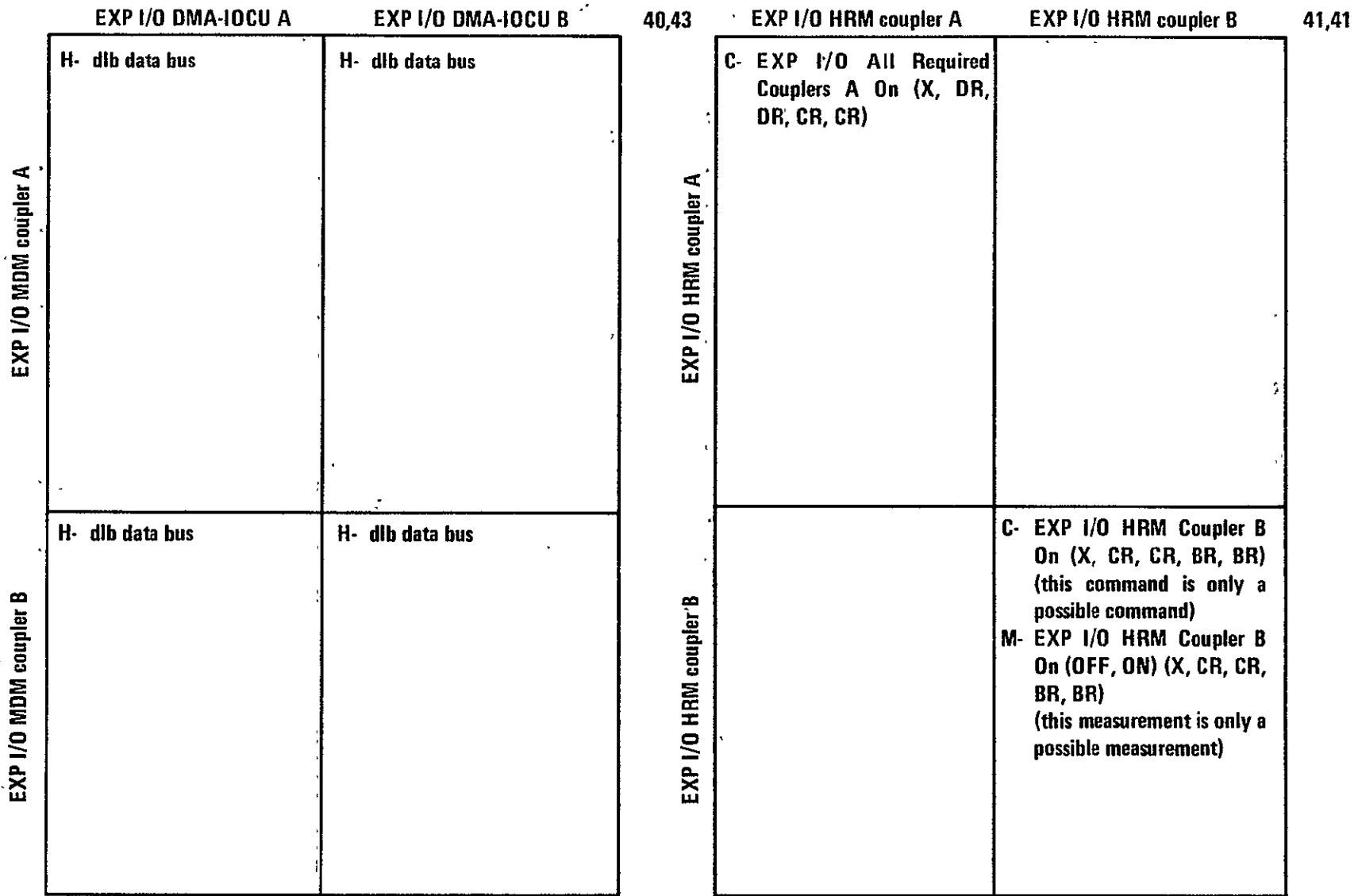

(p') 40,43 and 41,41.

Figure 4.- Continued.

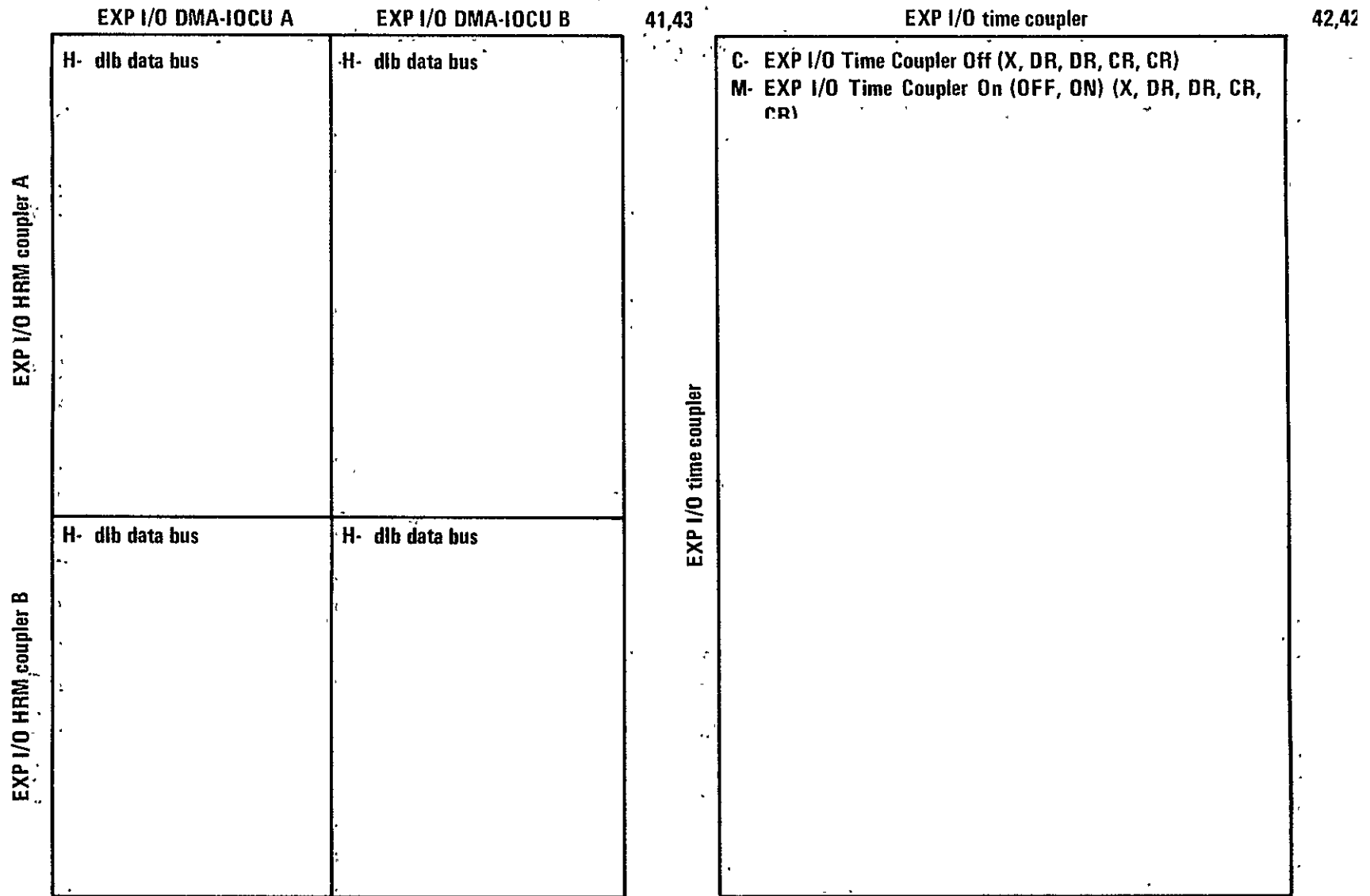

(q') 41,43 and 42,42.

Figure 4.- Continued.

EXP I/O time coupler

EXP I/O DMA-IOCU A		EXP I/O DMA-IOCU B		42,43	EXP I/O DMA-IOCU A		EXP I/O DMA-IOCU B		43,43
H- dlb data bus		H- dlb data bus		EXP I/O DMA-IOCU A	C- EXP I/O PWR On/DMA to EXP COMP (X, DR, DR, CR, CR) (turn power on) EXP I/O PWR A and B Off (X, DR, DR, CR, CR)				EXP I/O DMA-IOCU B
					M- EXP I/O PWR A On (OFF, ON) (X, DR, DR, CR, CR) EXP I/O DMA-IOCU Coupler BITE (GO, NOGO) (X, DR, DR, CR, CR)				
						C- EXP I/O PWR B On (X, CR, CR, DR, DR) EXP I/O PWR A and B Off (X, DR, DR, CR, CR)			
						M- EXP I/O PWR B On (OFF, ON) (X, CR, CR, BR, BR) EXP I/O DMA-IOCU Coupler BITE (GO, NOGO) (X, DR, DR, CR, CR)			

(r) 42,43 and 43,43.

Figure 4.- Continued.

EXP I/O DMA-IOCU B

BU COMP CPU

43,47

- M- EXP I/O DMA-IOCU to BU COMP (CONN) (X, CR, CR, BR, BR)
- C- BU COMP PWR On/EXP DMA to BU COMP (X, CR, CR, BR, BR)
(opens hardware link between EXP I/O DMA-IOCU B and BU COMP CPU)
BU COMP PWR Off/AUTO RESTART Off (Y, MR, MR, MR, MR)
(closes hardware link between EXP I/O DMA-IOCU B and BU COMP CPU)
EXP I/O PWR A and B Off (X, DR, DR, CR, CR)
(closes hardware link between EXP I/O DMA-IOCU B and BU COMP CPU)
- H- dlb data bus

EXP COMP CPU

43,49

EXP I/O DMA-IOCU A

- C- EXP COMP PWR On (EXP DMA to EXP COMP) (X, DR, DR, CR, CR) -
(opens hardware link between EXP I/O DMA-IOCU A and EXP COMP CPU)
EXP COMP PWR Off/AUTO RESTART Off (X, DR, DR, CR, CR)
(closes hardware link between EXP I/O DMA-IOCU A and EXP COMP CPU)
EXP I/O PWR A and B Off (X, DR, DR, CR, CR)
(closes hardware link between EXP I/O DMA-IOCU A and EXP COMP CPU)
EXP I/O PWR A On/DMA to EXP COMP (X, DR, DR, CR, CR)
(opens hardware link between EXP I/O DMA-IOCU A and EXP COMP CPU)
- M- EXP I/O DMA-IOCU to EXP COMP (CONN) (X, CR, CR, BR, BR)
- H- dlb data bus

(s') 43,47 and 43,49.

Figure 4.- Continued.

SS:COMP CPU

SS COMP CPU

45,45

M- SS COMP CPU TEMP (Deg C, -40, +100) (C, C, C, B, B)

SS COMP memory

45,46

H- dlb memory bus and address bus

SS COMP CPU

(t') 45,45 and 45,46.

Figure 4.- Continued.

SS COMP memory

SS COMP memory

46,46

M- SS COMP Memory TEMP (Deg C, -40, +100) (C, C, C, B, B)

BU COMP CPU

47,47

M- BU COMP CPU TEMP (Deg C, -40, +100) (C, D, D, C, C)

BU COMP CPU

(u') 46,46 and 47,47.

Figure 4.- Continued.

BU COMP CPU

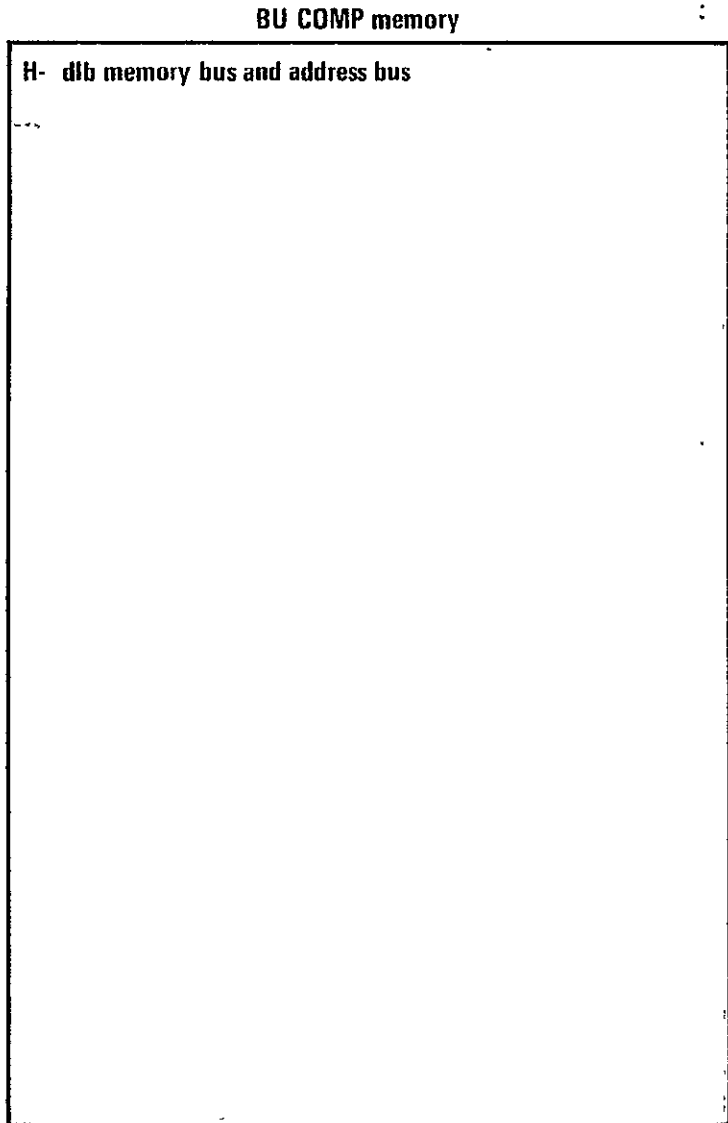

BU COMP memory

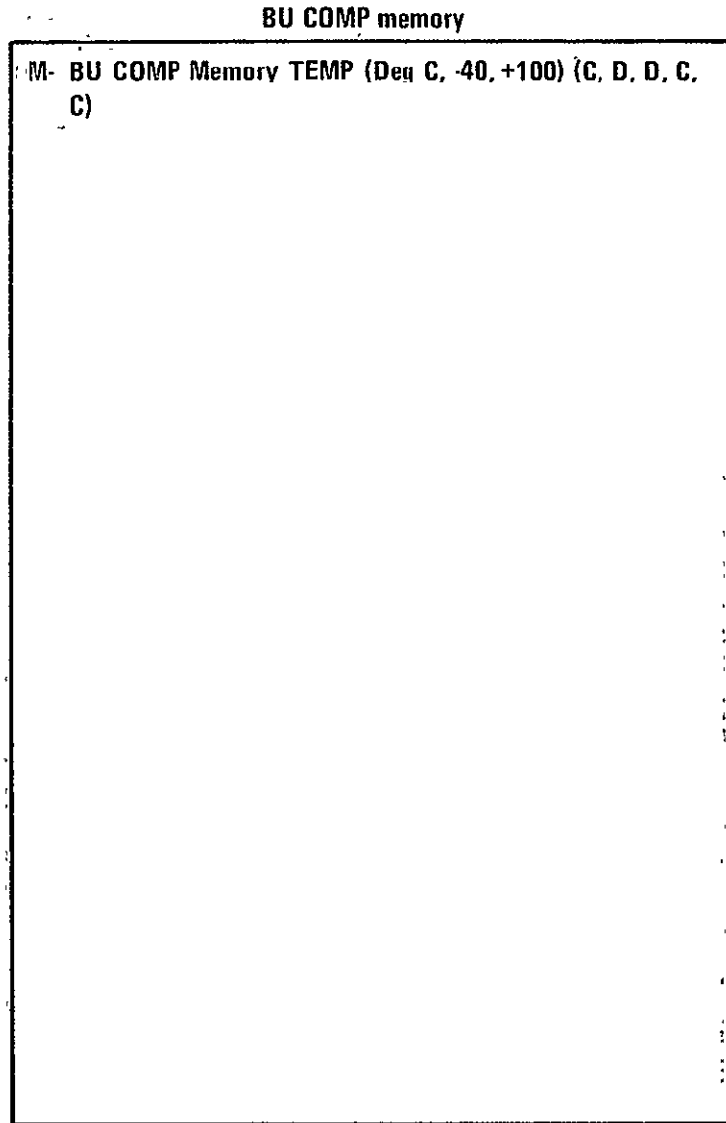

(v') 47,48 and 48,48.

Figure 4.- Continued.

001

EXP COMP CPU

EXP COMP CPU

49,49

M- EXP COMP CPU TEMP (Deg C, -40, +100) (C, D, D, C, C)

EXP COMP memory

49,50

H- dlb memory bus and address bus

EXP COMP CPU

(w') 49,49 and 49,50.

Figure 4.- Continued.

EXP COMP memory

50,50

M- EXP COMP Memory (Deg C, -40, +100) (C, D, D, C, C)

EXP COMP memory



(x') 50,50.

Figure 4.- Concluded.

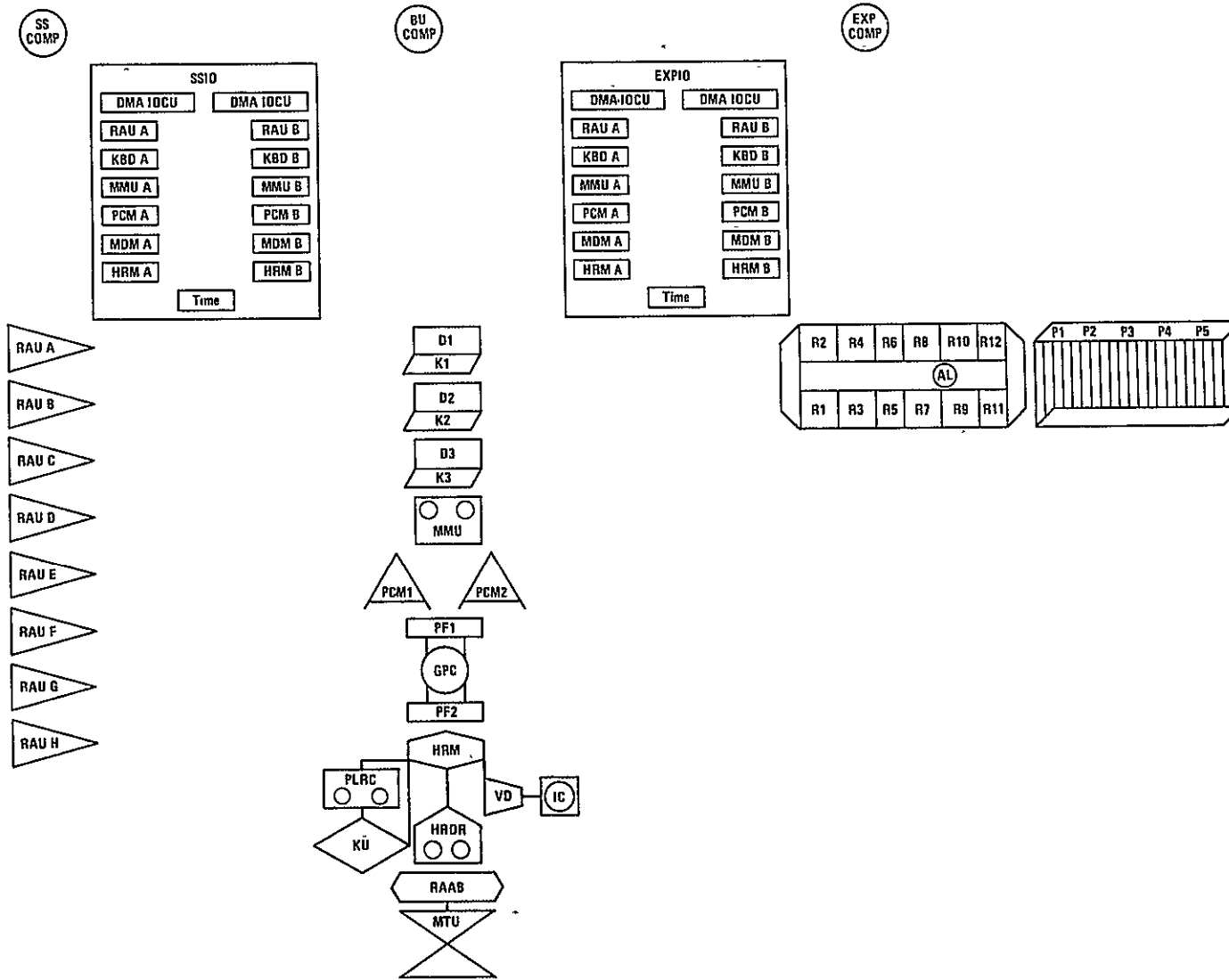
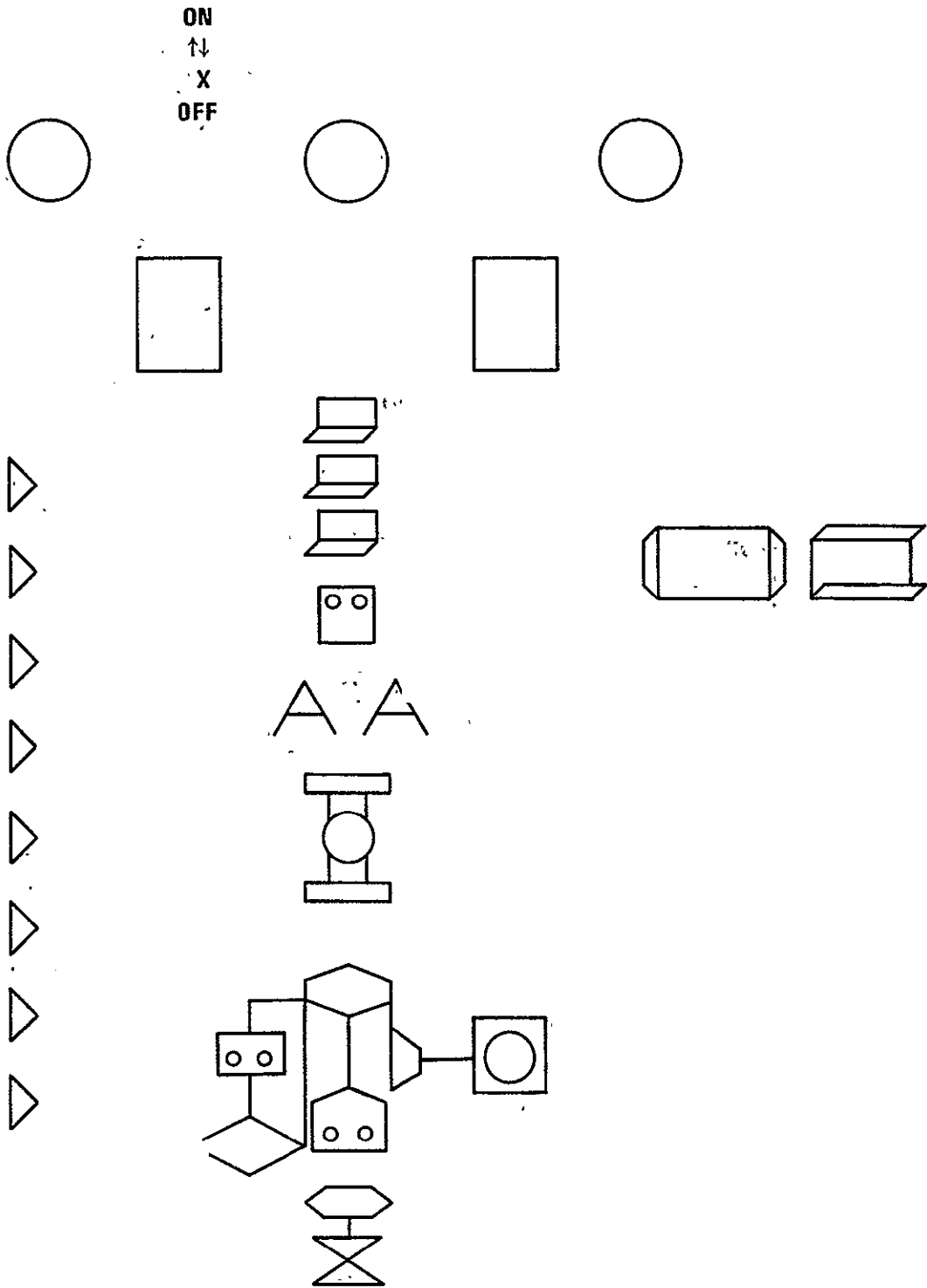

Figure 5.- The overall CDMS schematic diagram.

MSTR
PWR

1,1



(a) 1,1.

Figure 6.- Theoretical CDMS schematic displays.

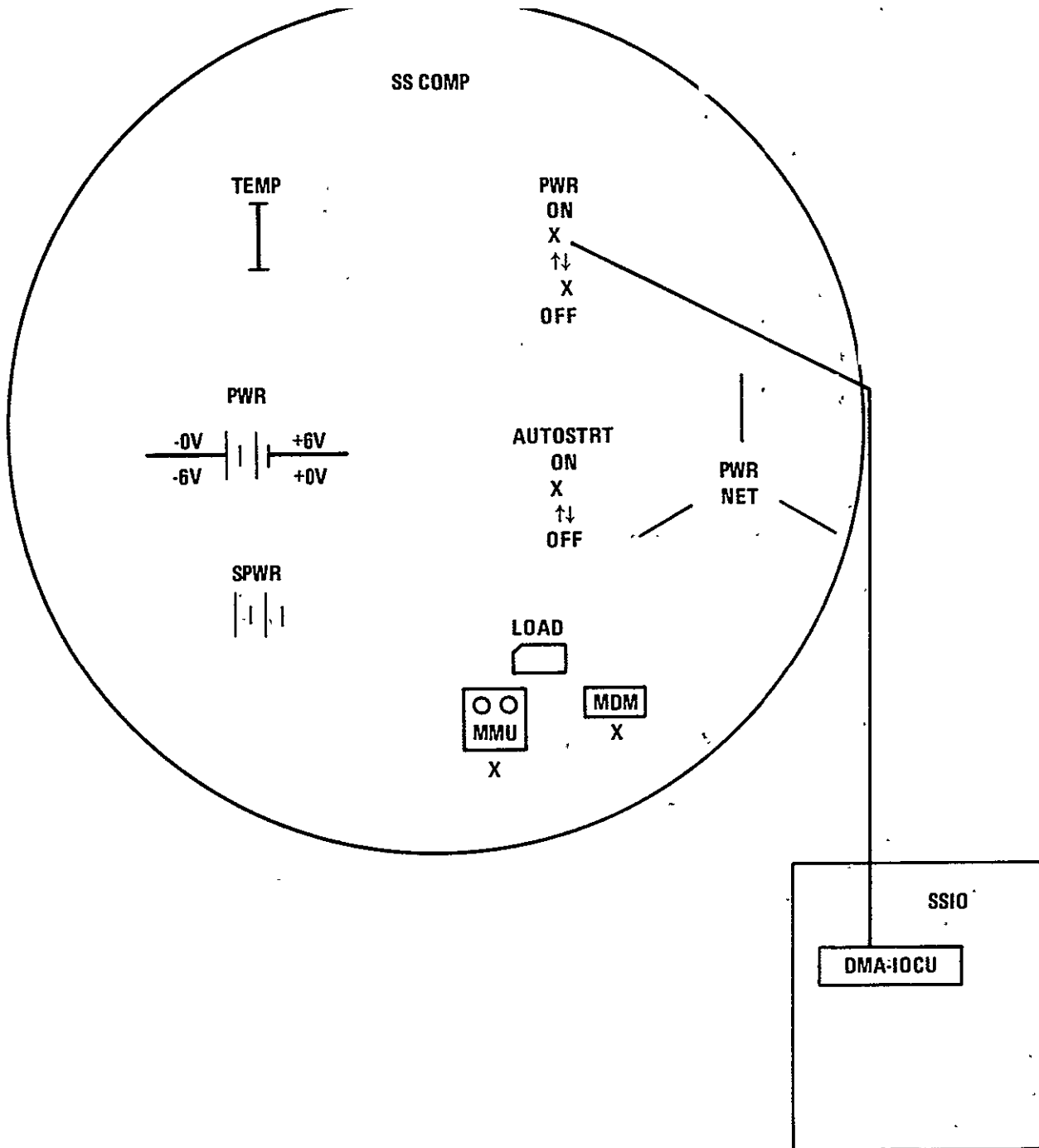

(b) 2,2.

Figure 6.- Continued.

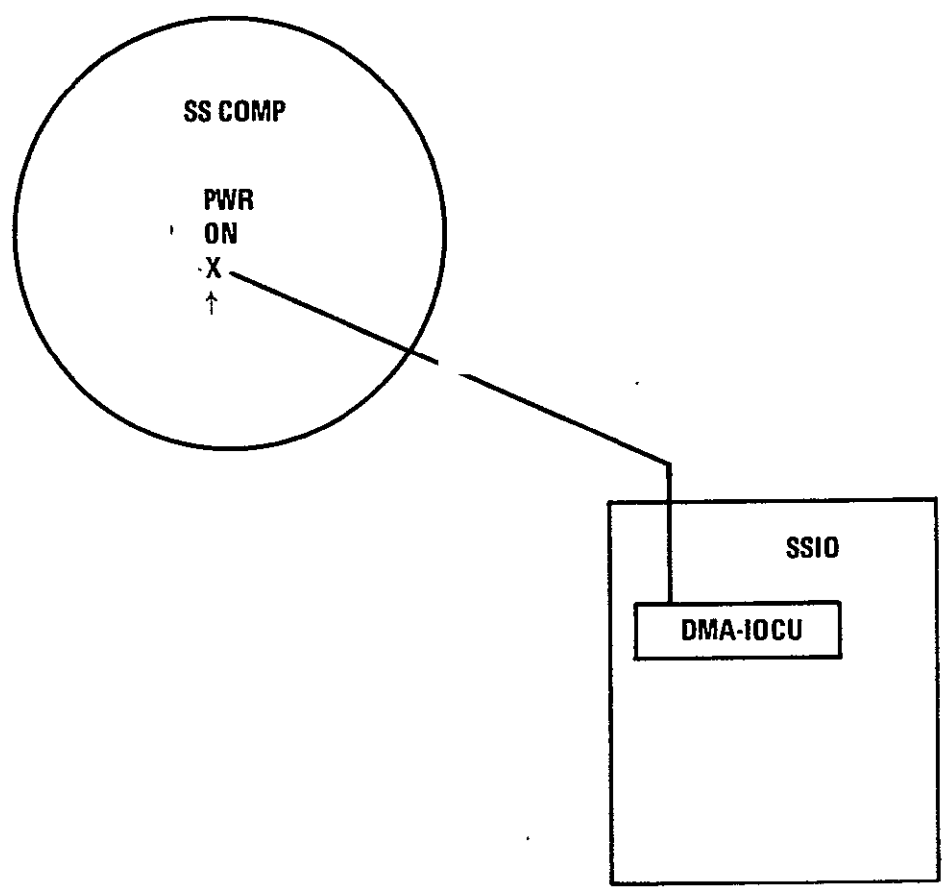

(c) 2,4.

Figure 6.- Continued.

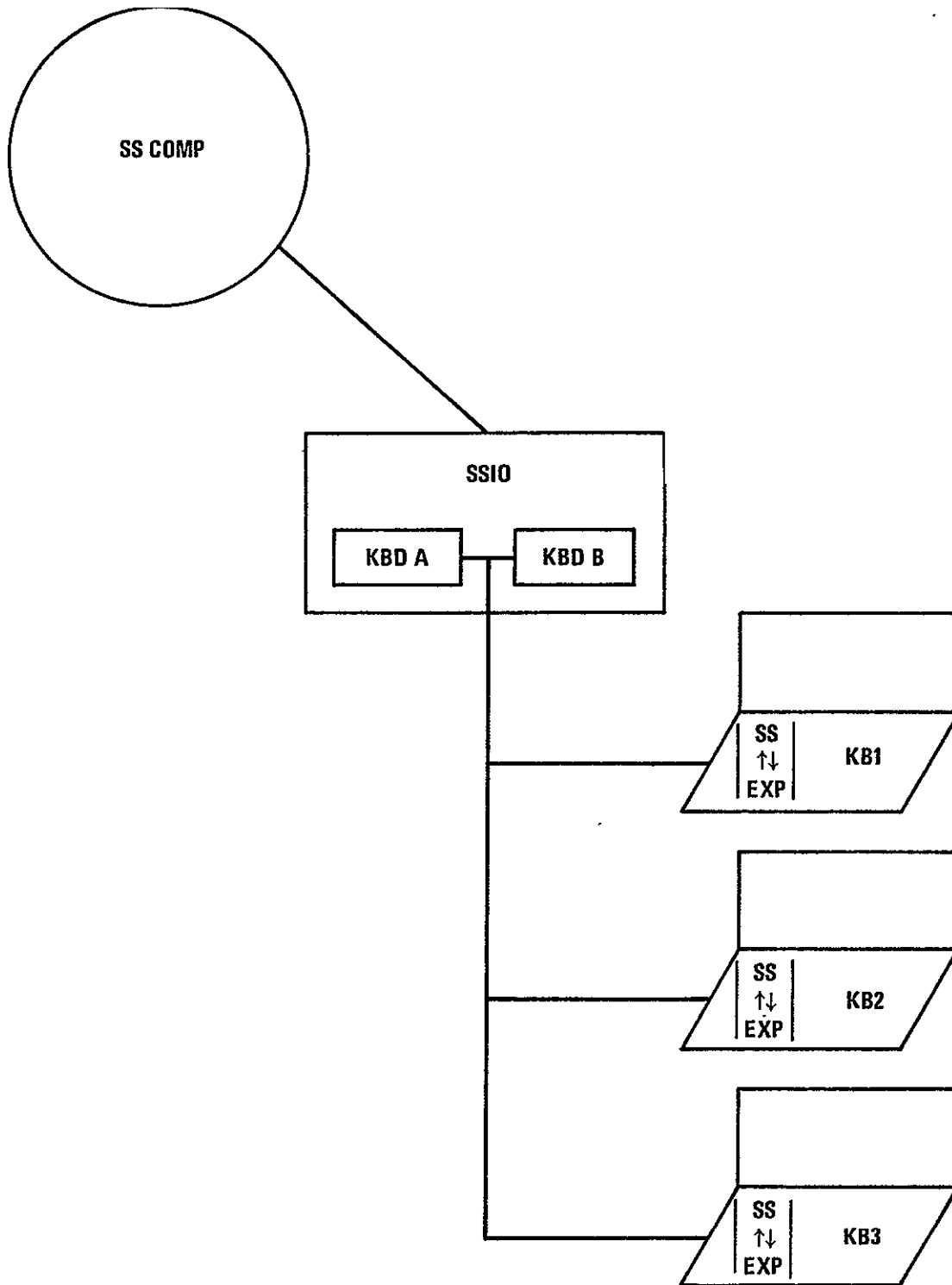

(d) 2,13.

Figure 6.- Continued.

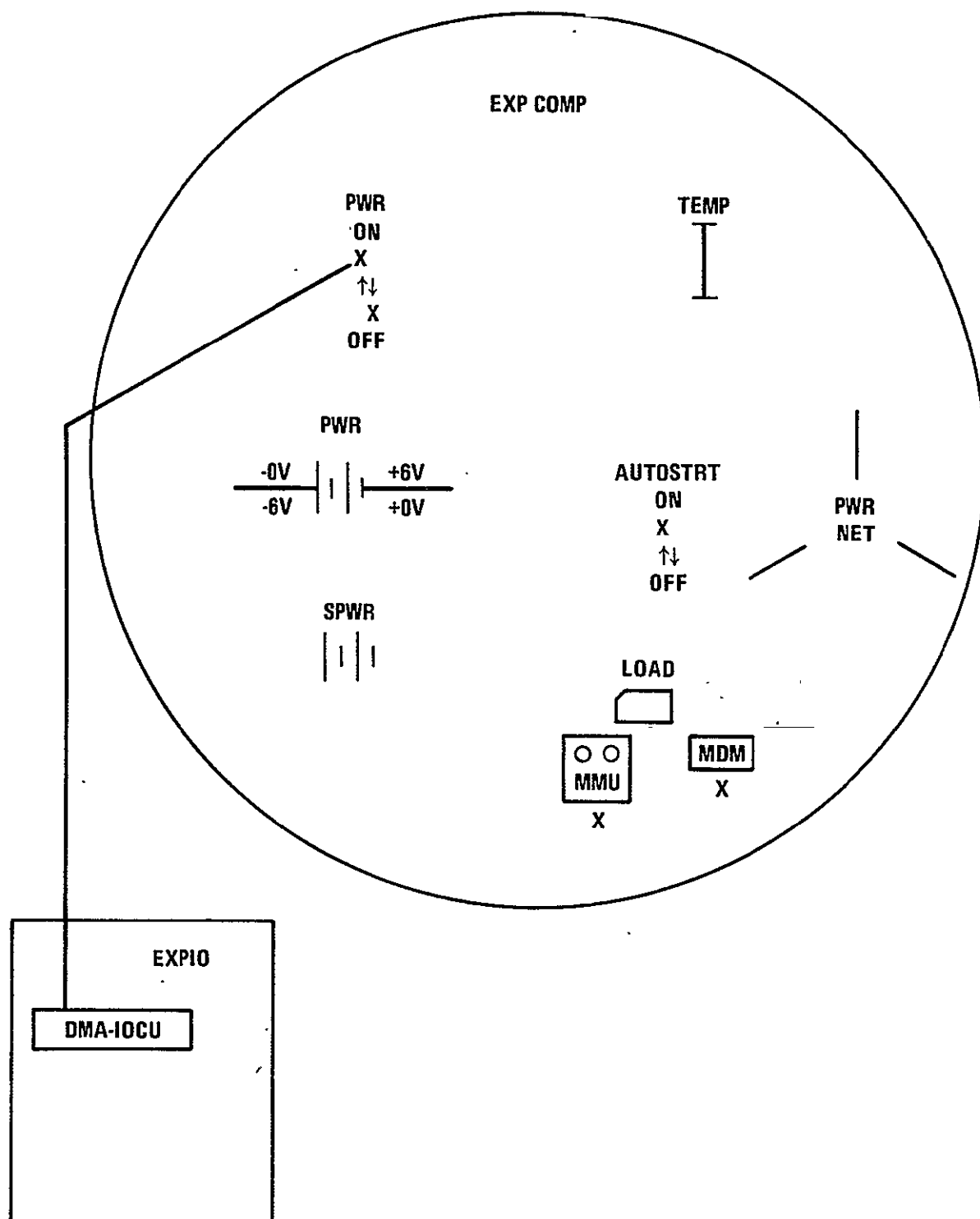

(e) 3,3.
Figure 6.- Continued.

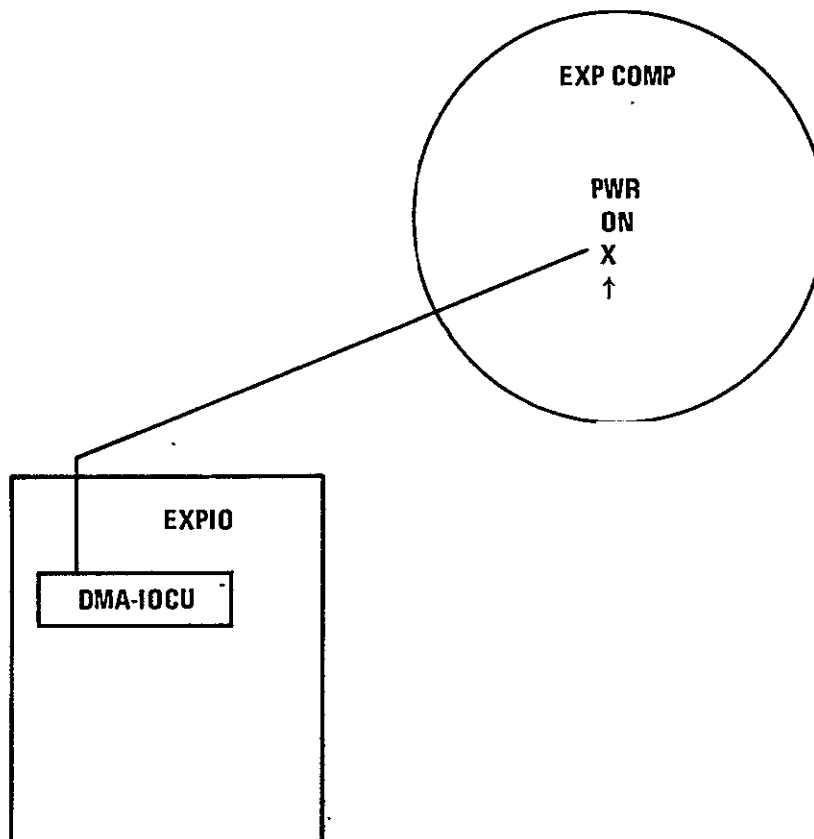

(f) 3,5.

Figure 6.- Continued.

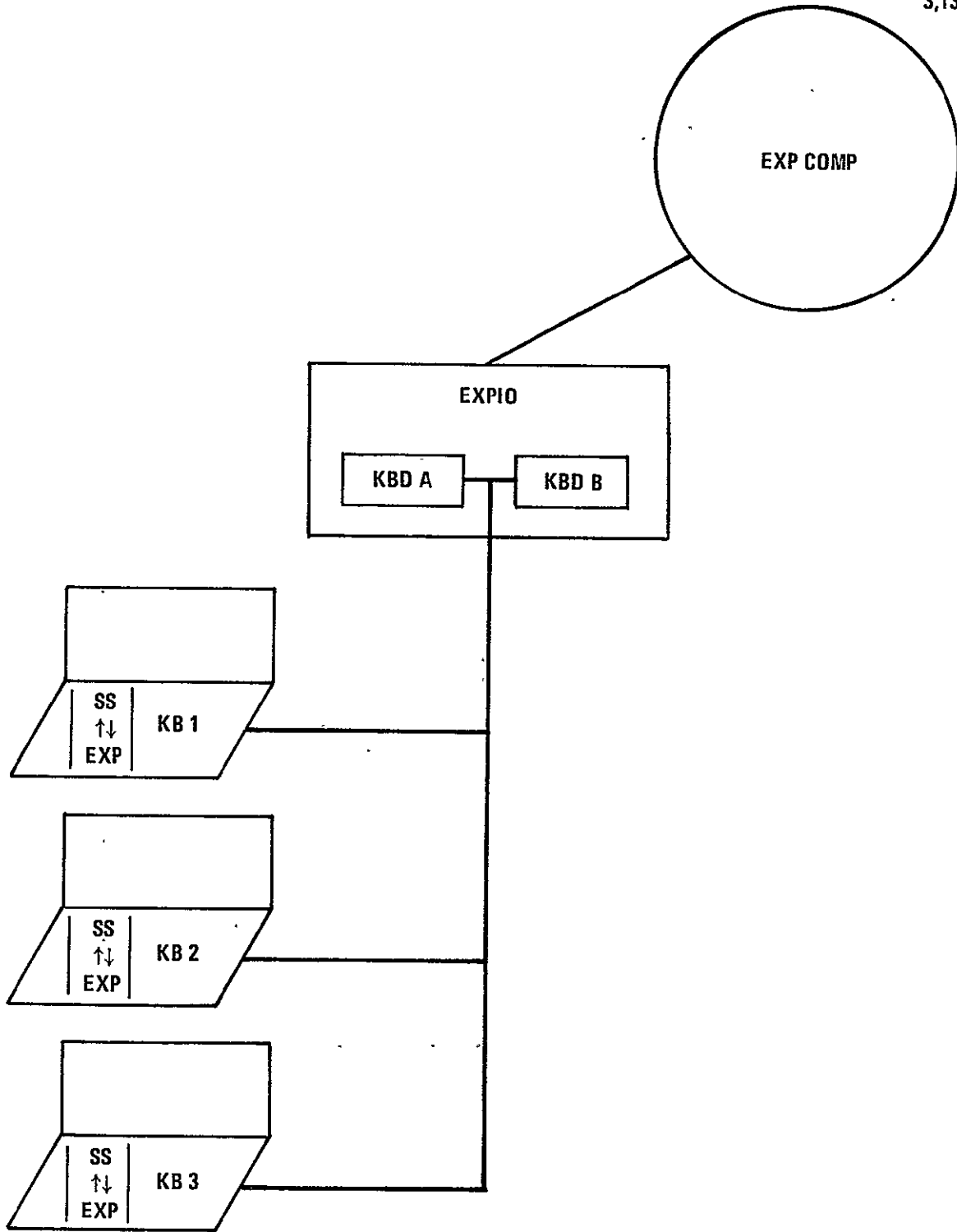

(g) 3,13.

Figure 6.- Continued.

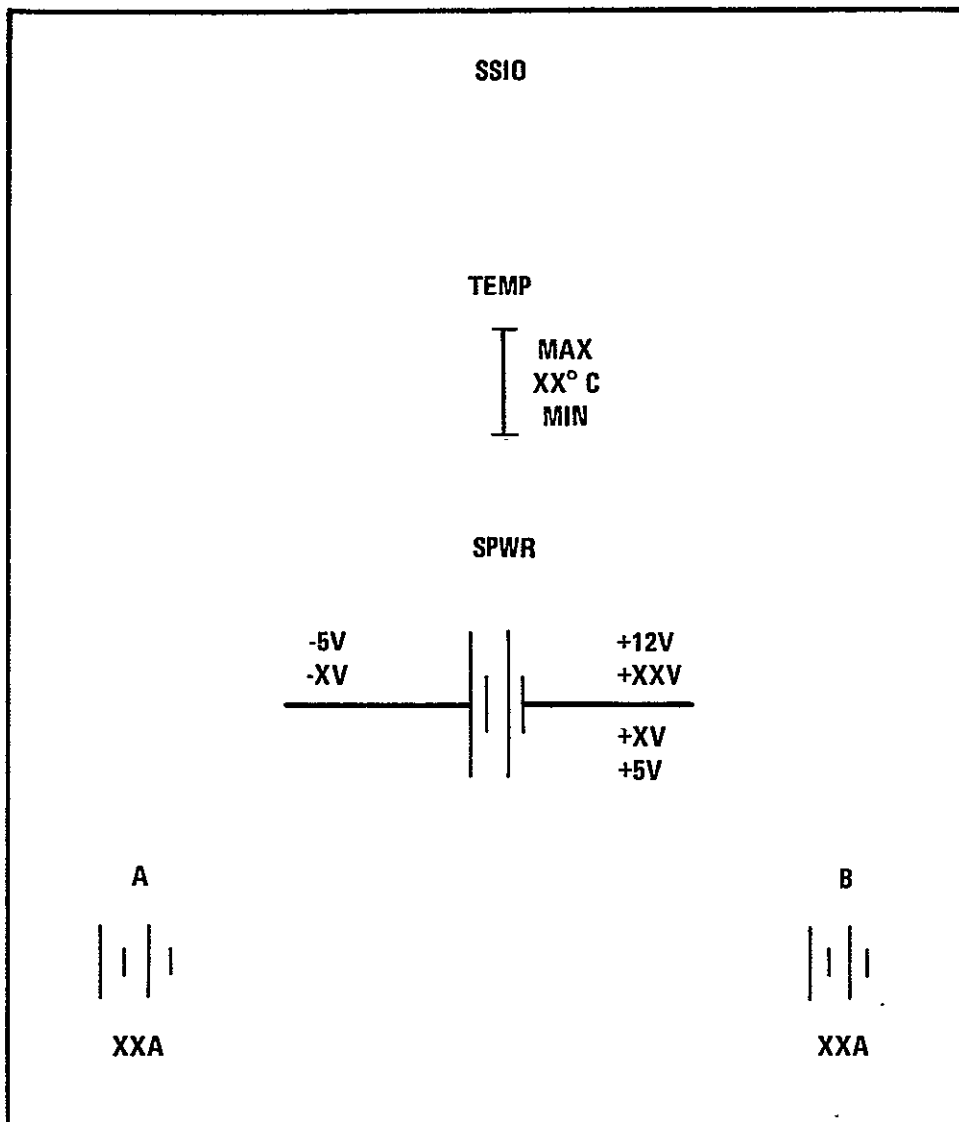

(h) 4,4.

Figure 6.- Continued.

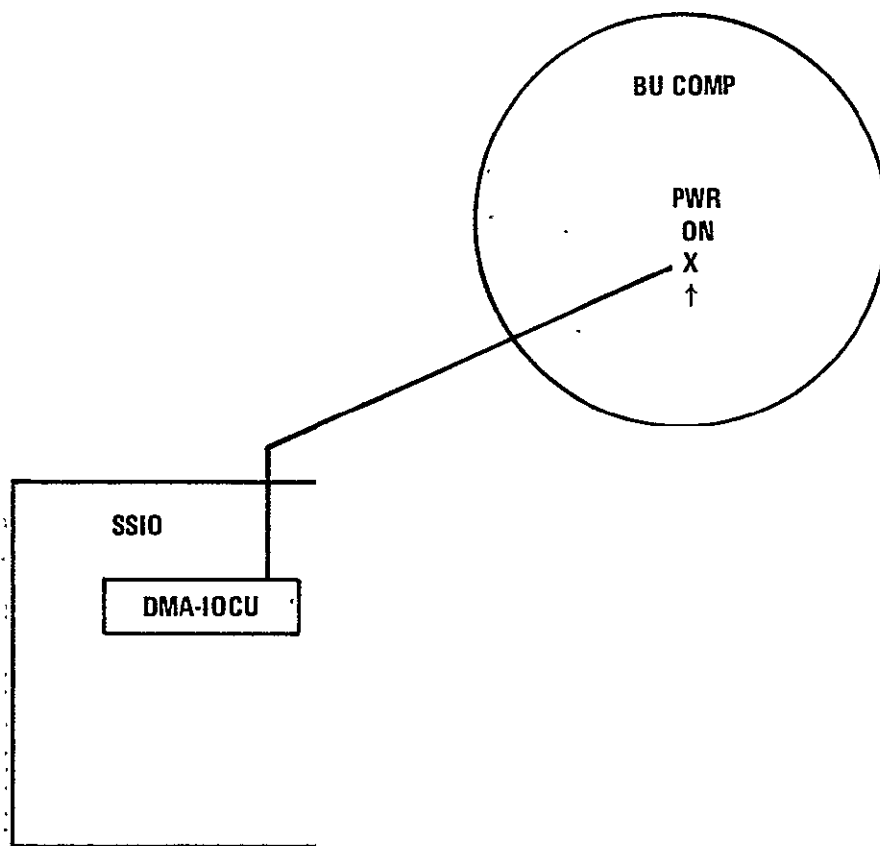

(i) 4,6.

Figure 6.- Continued.

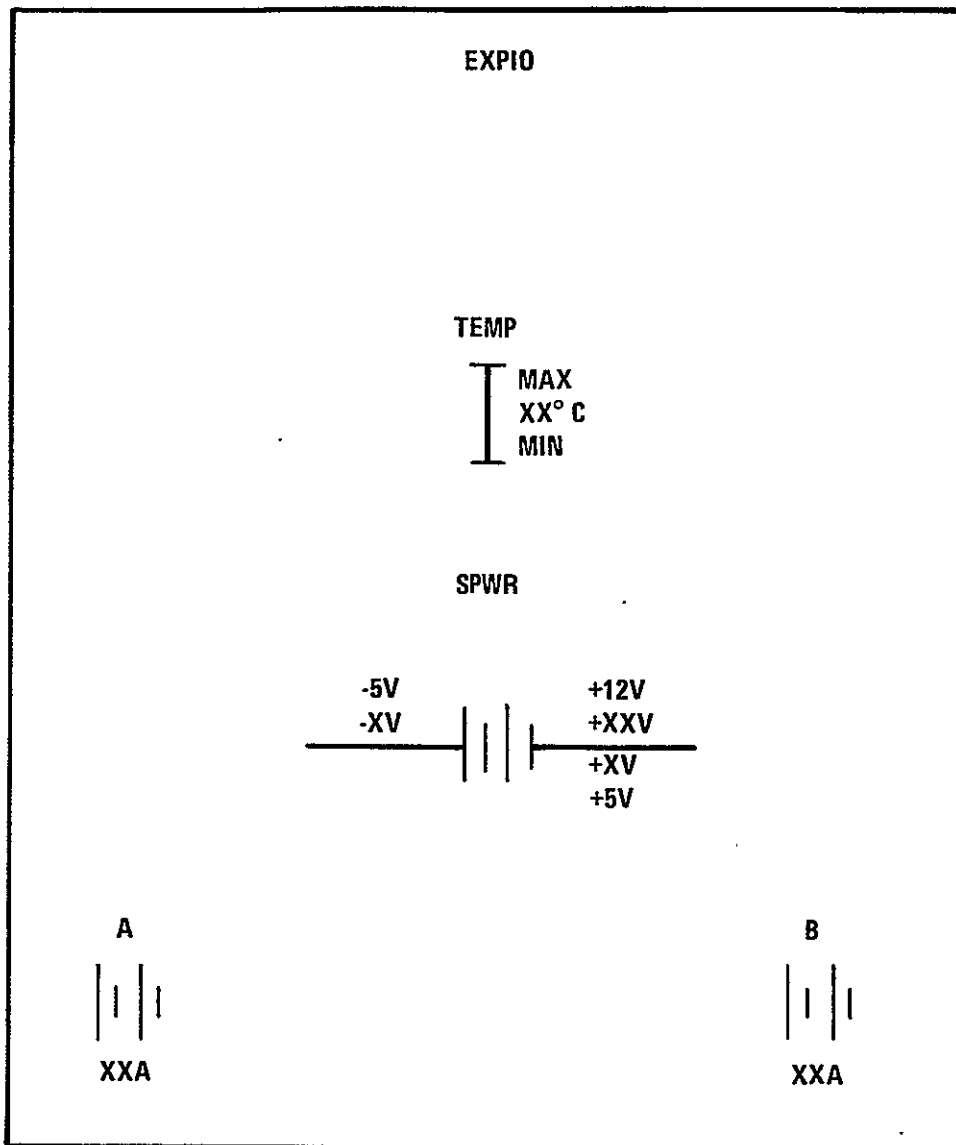

(j) 5,5.

Figure 6.- Continued.

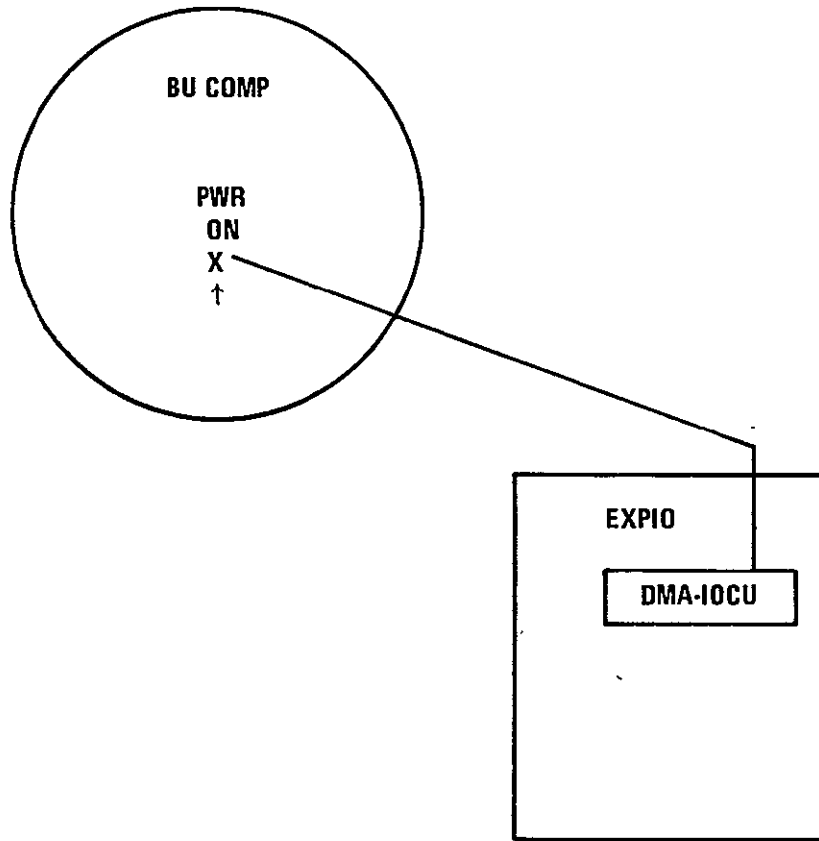

(k) 5,6.

Figure 6.- Continued.

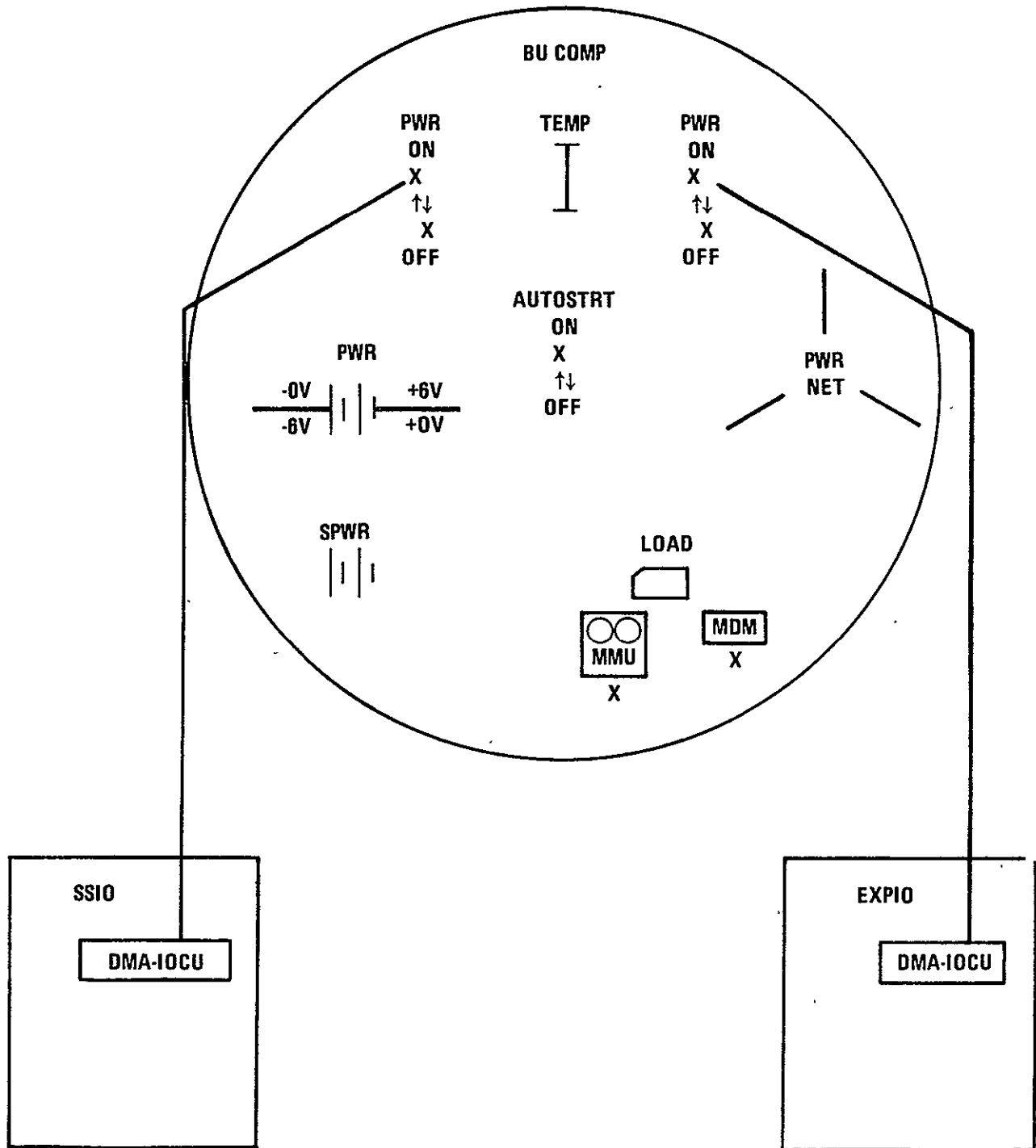

(1) 6,6.

Figure 6.- Continued.

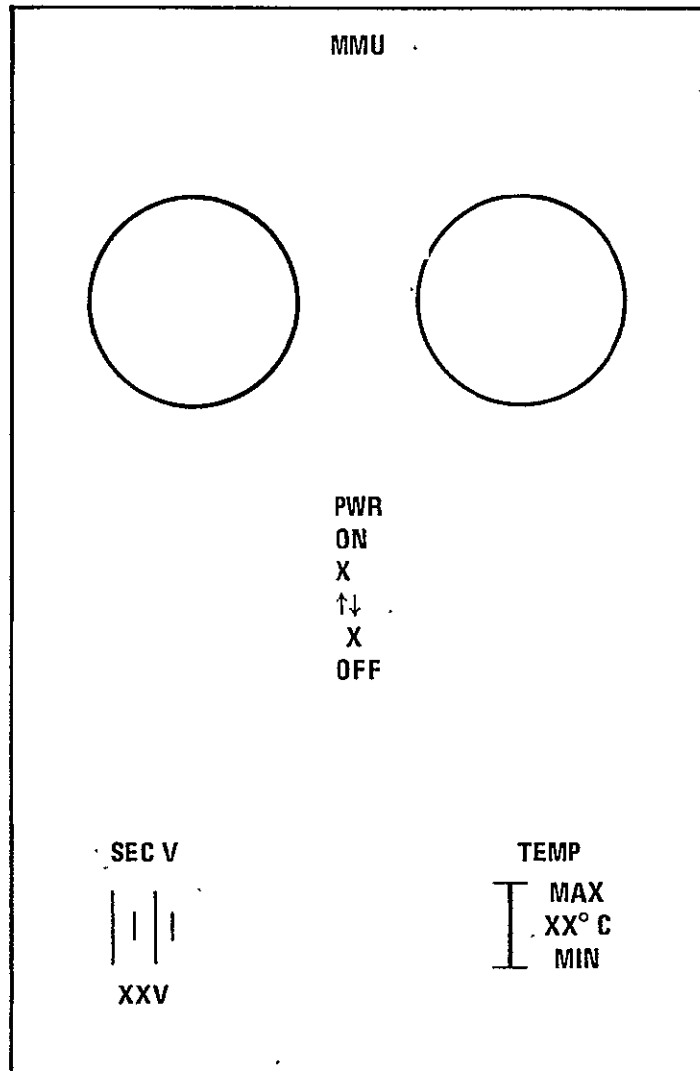

(m) 7,7.

Figure 6.- Continued.

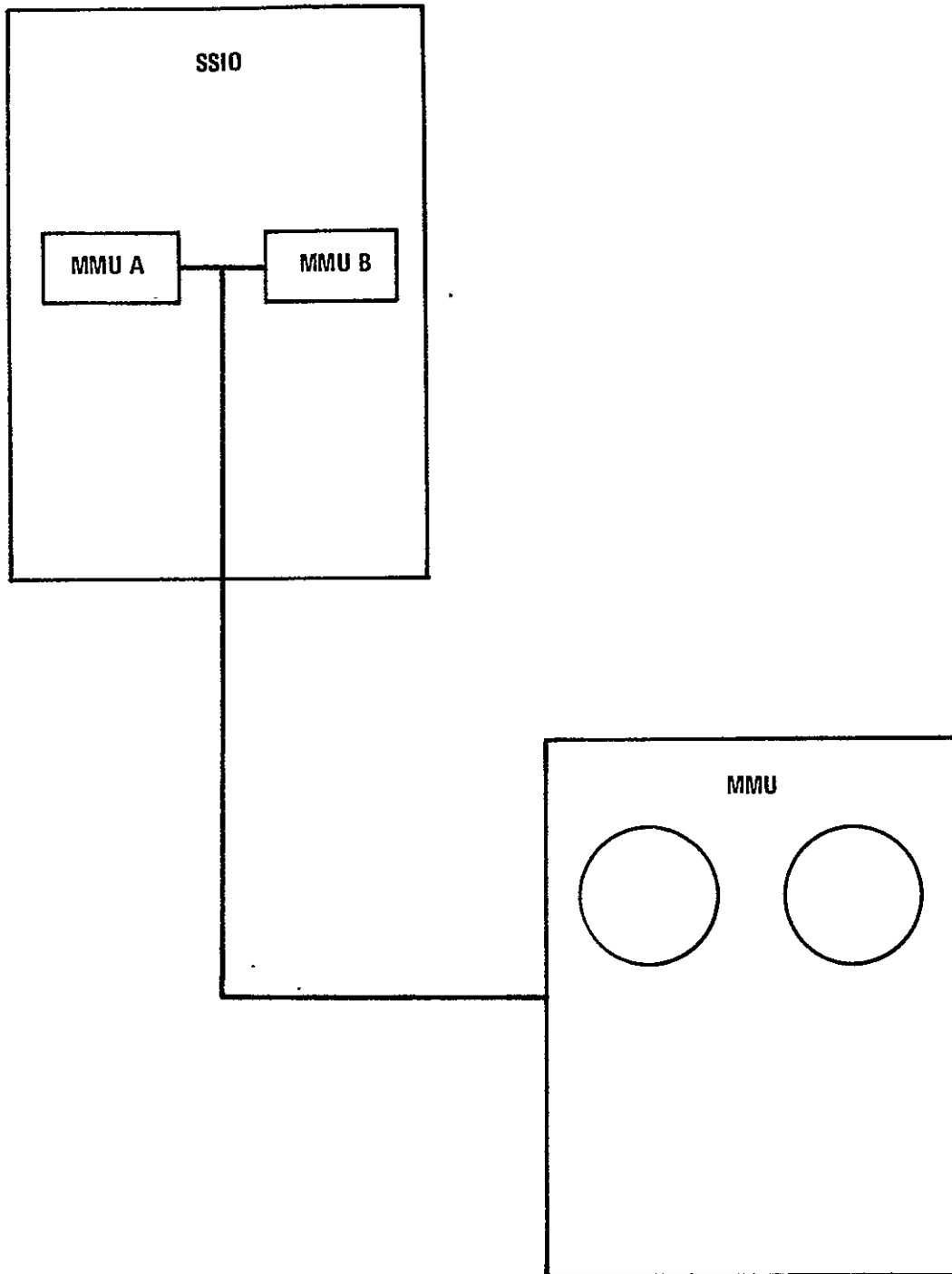

(n) 7,25.

Figure 6.- Continued.

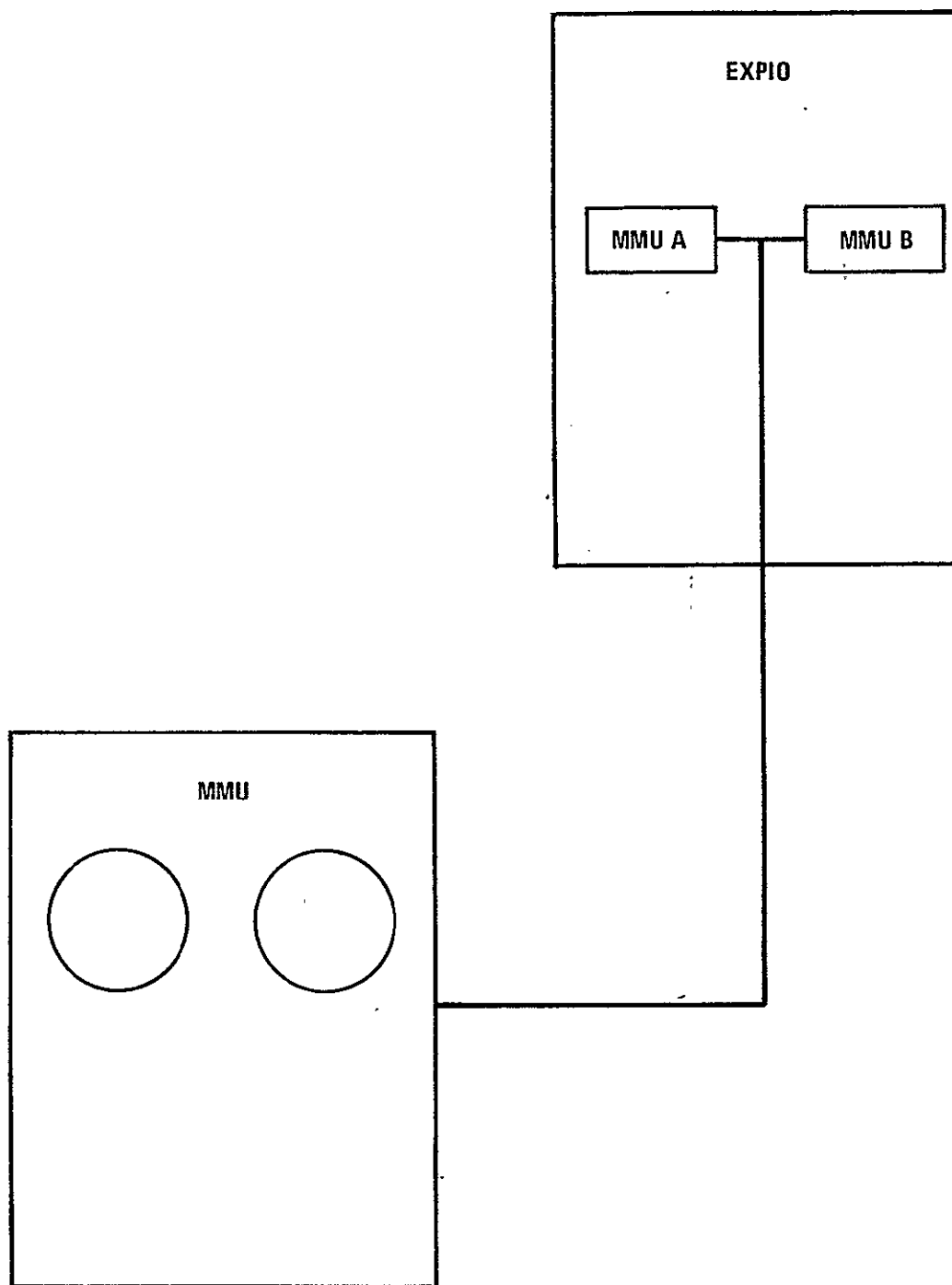

(o) 7,38.

Figure 6.- Continued.

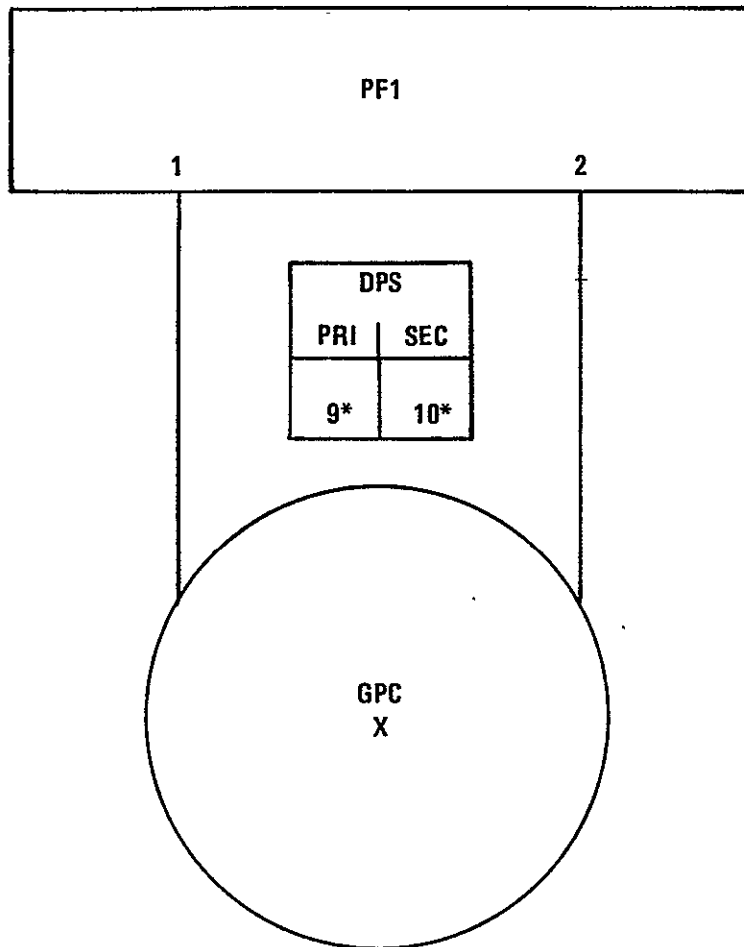

(p) 8,9.

Figure 6.- Continued.

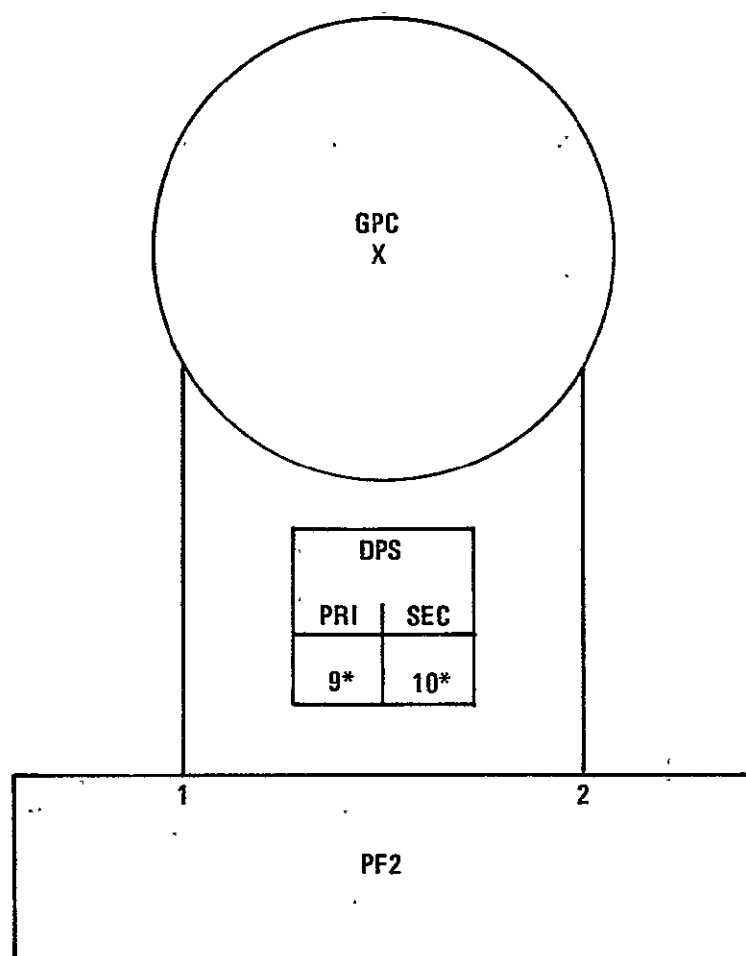

(q) 8,10.

Figure 6.- Continued.

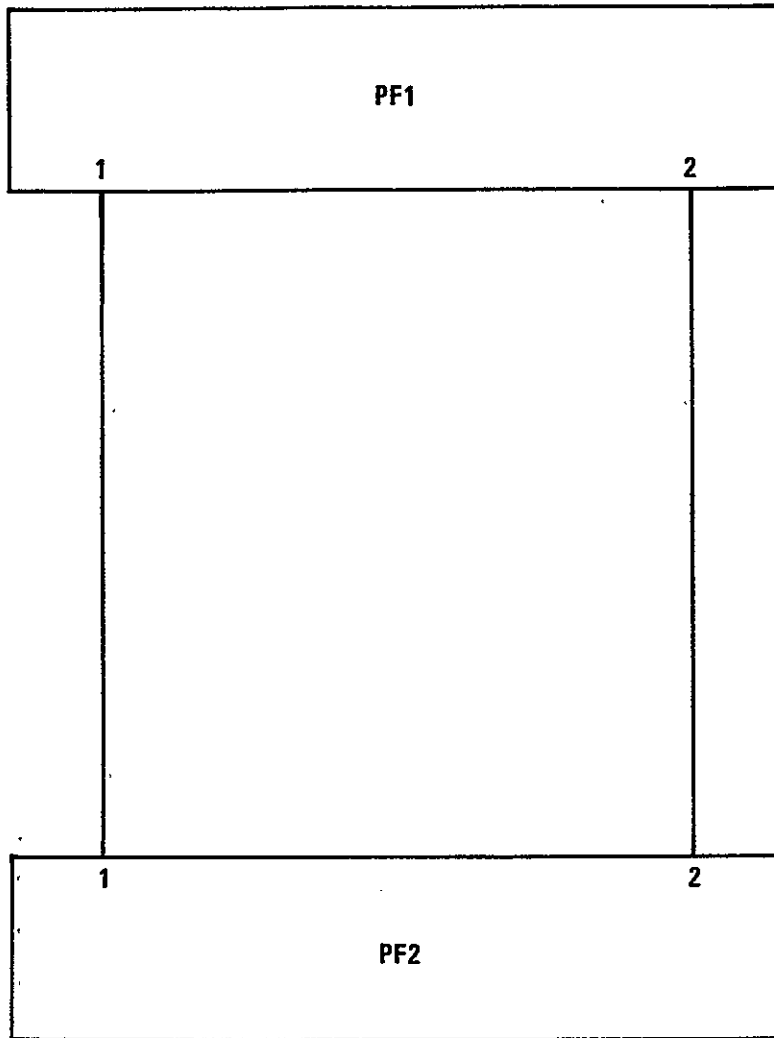

(r) 9,10.

Figure 6.- Continued.

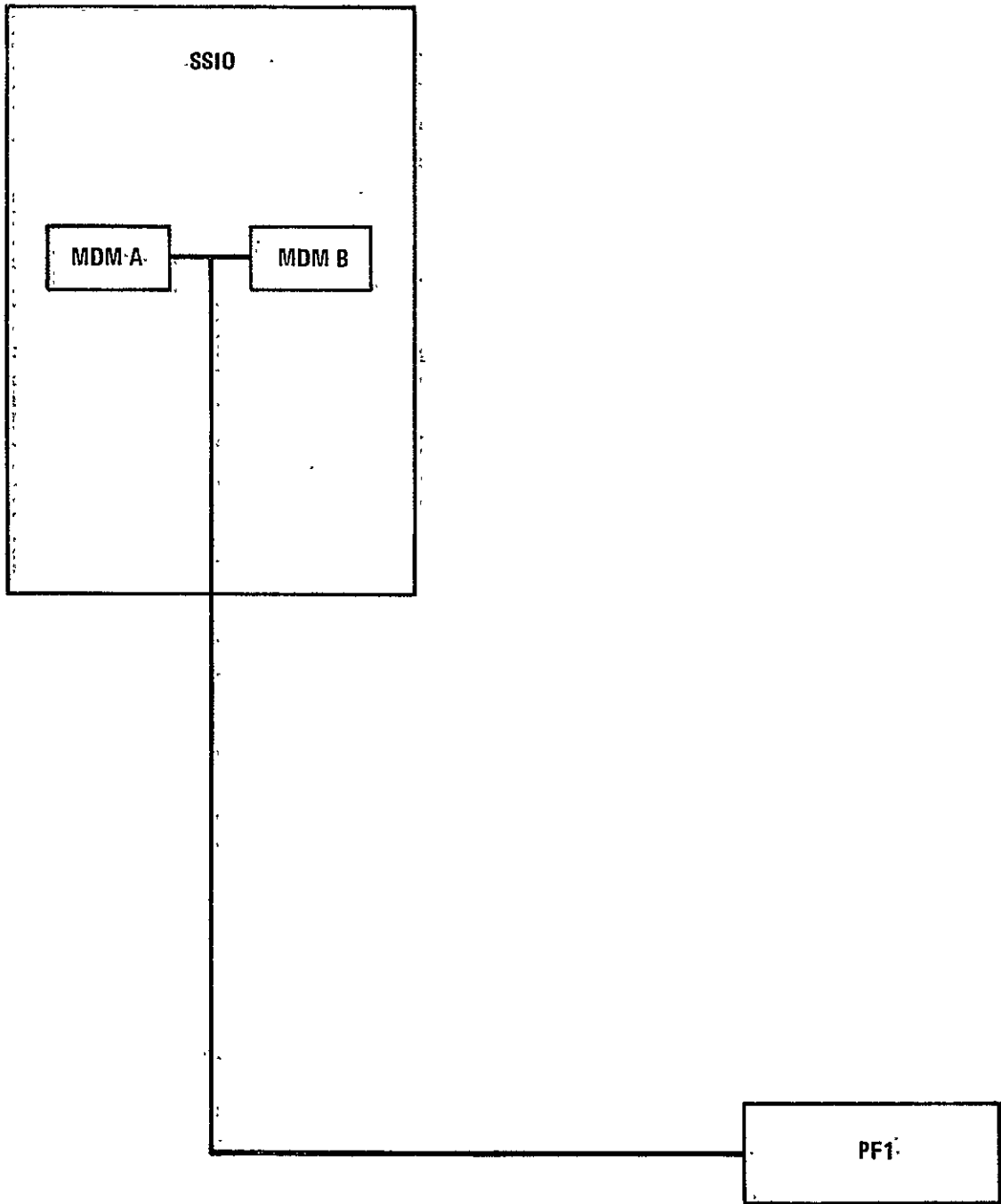

(s) 9,27.

Figure 6.- Continued.

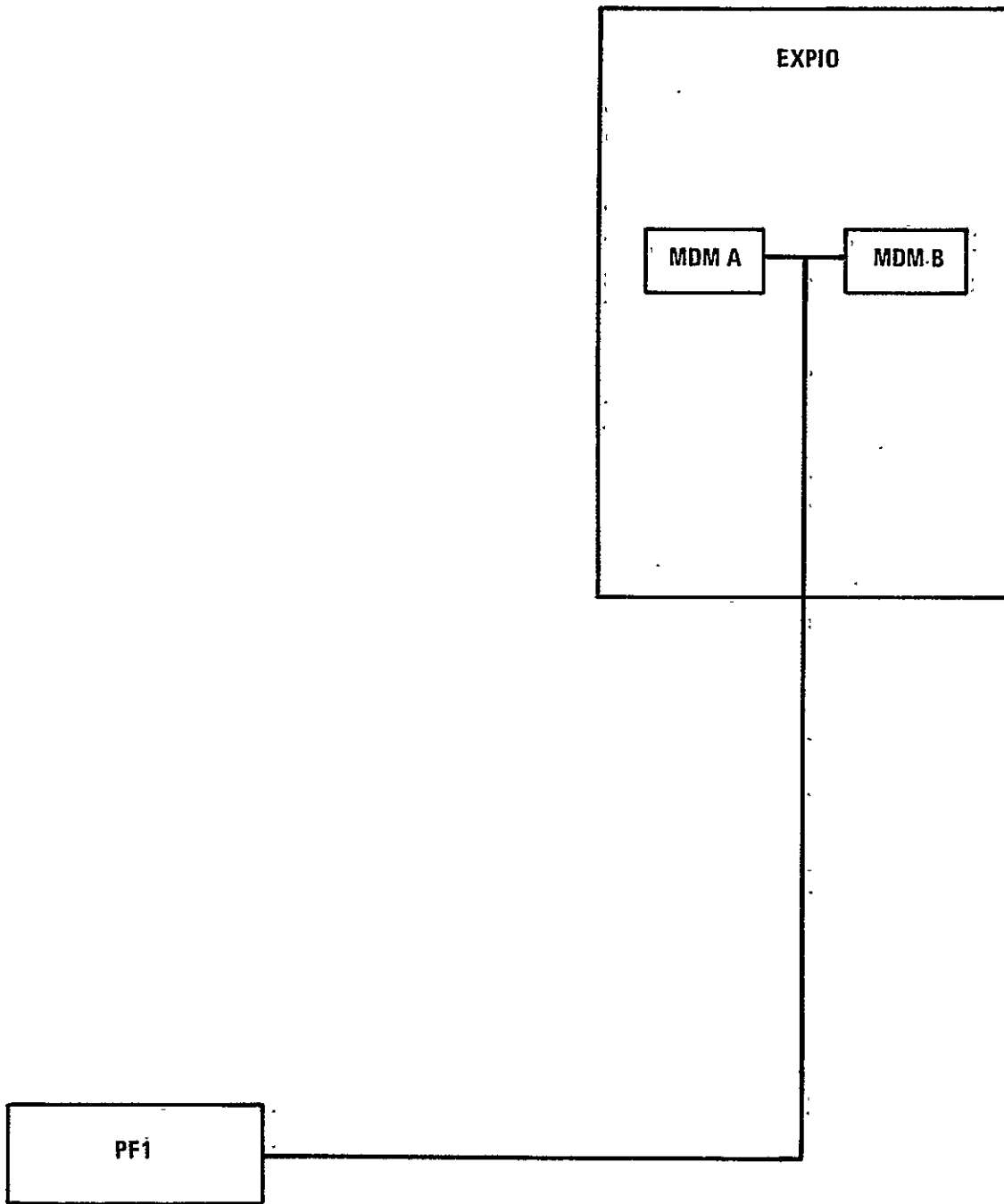

(t) 9,40.

Figure 6.- Continued

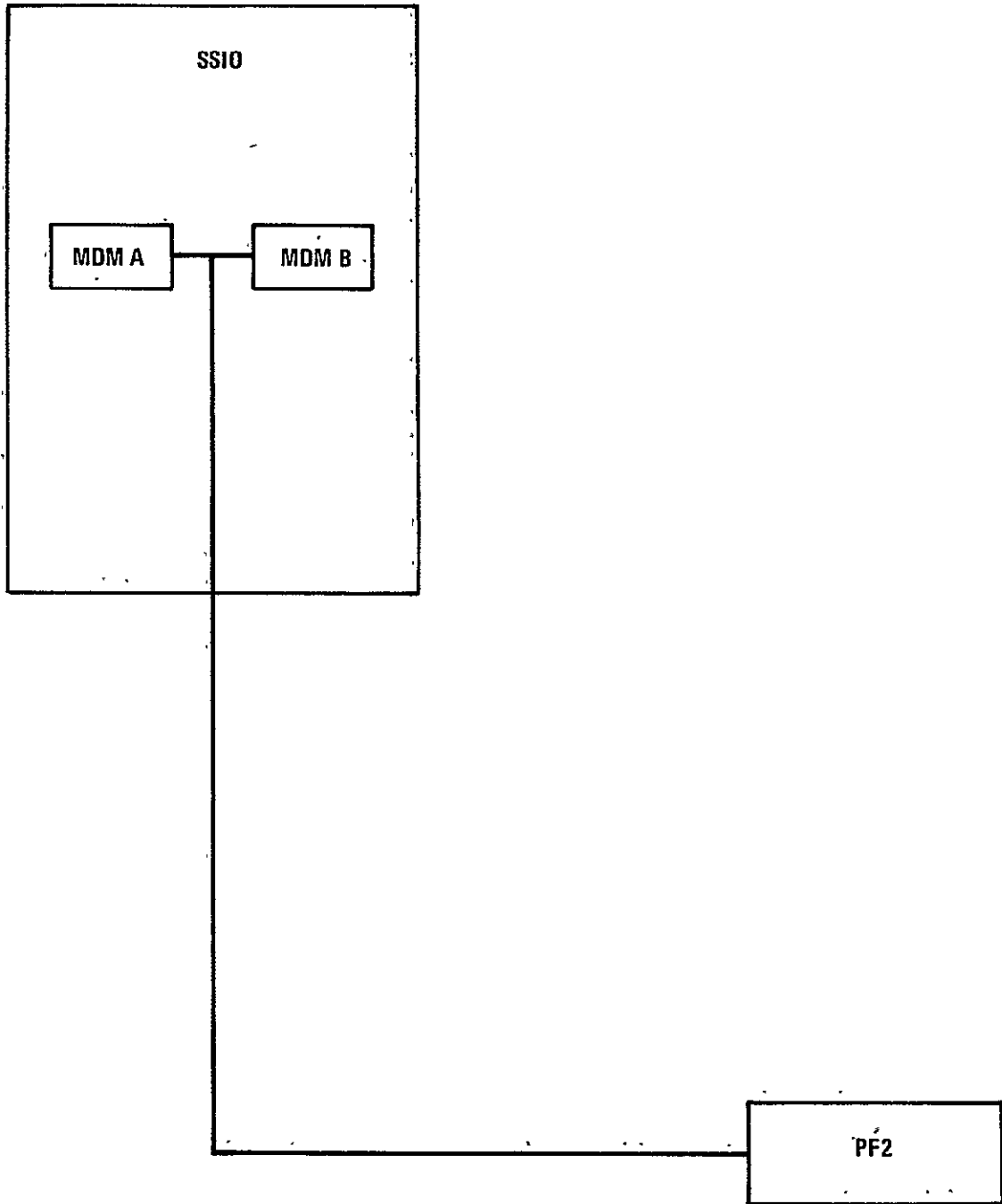

(u) 10,27.

Figure 6.- Continued.

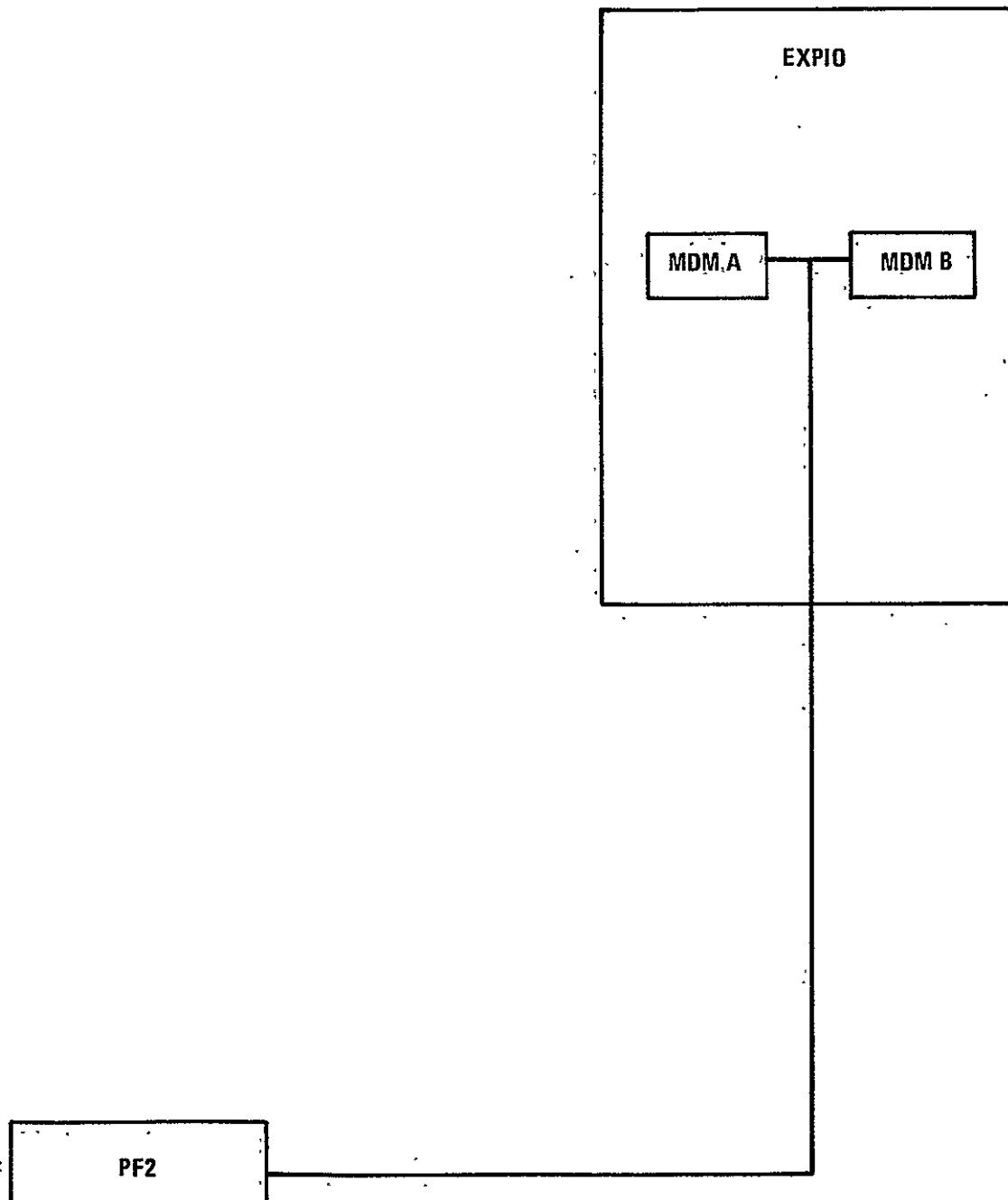

(v) 10,40.

Figure 6.- Continued.

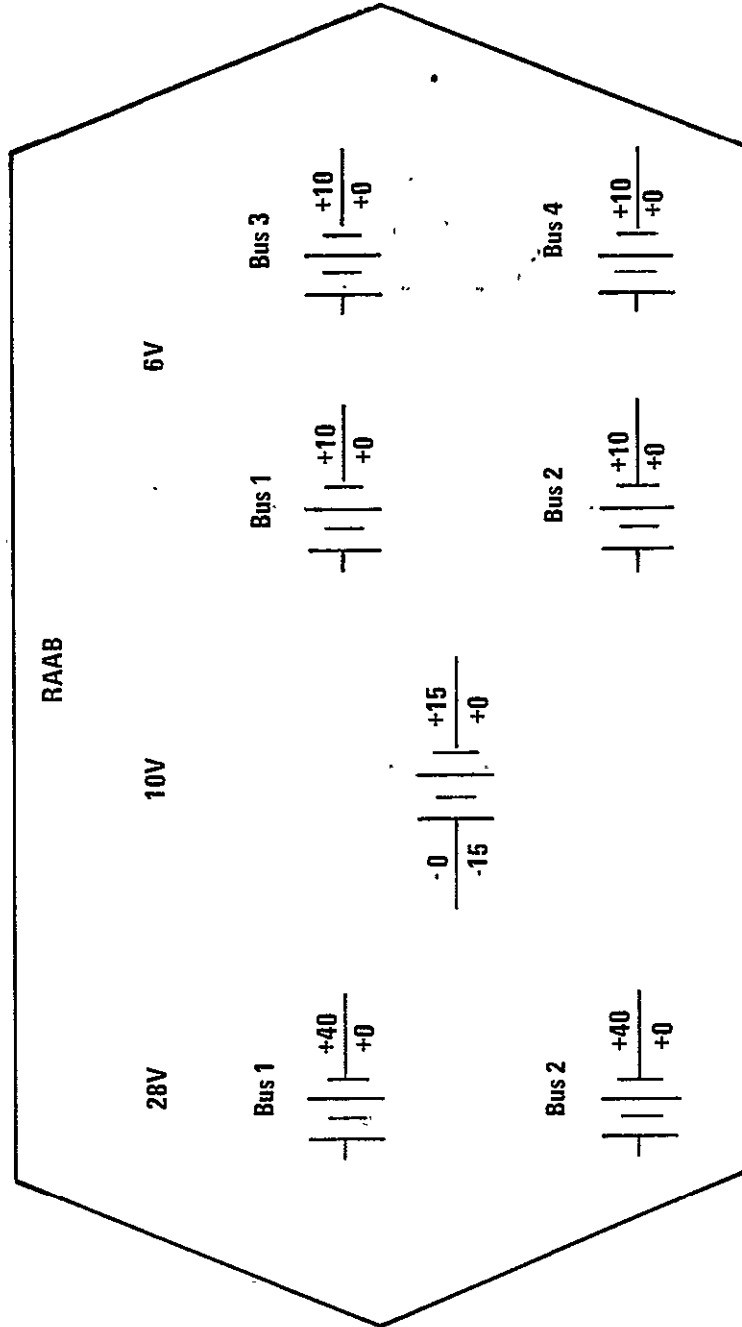

(w) 11,11.

Figure 6.- Continued.

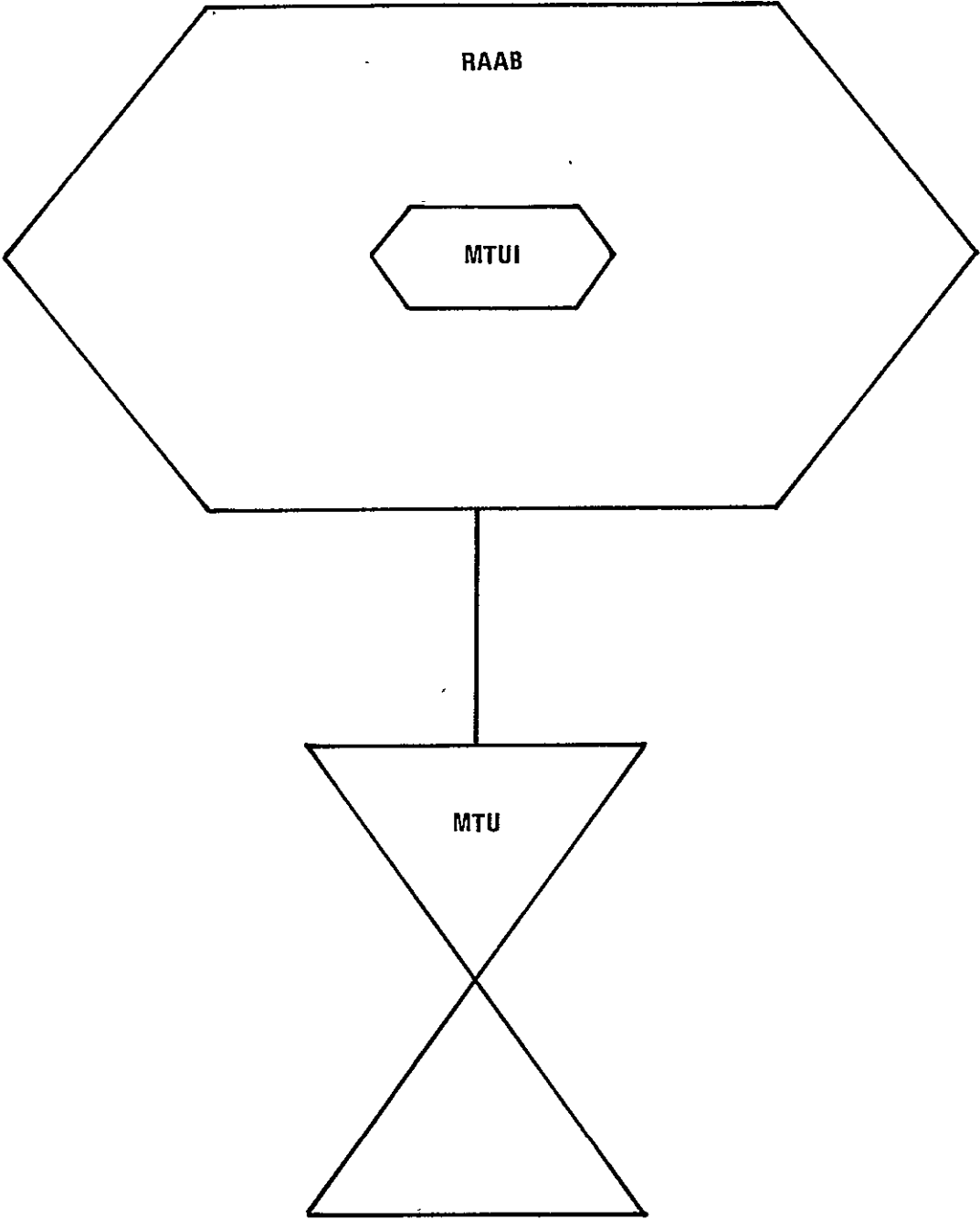

(x) 11,19.

Figure 6.- Continued.

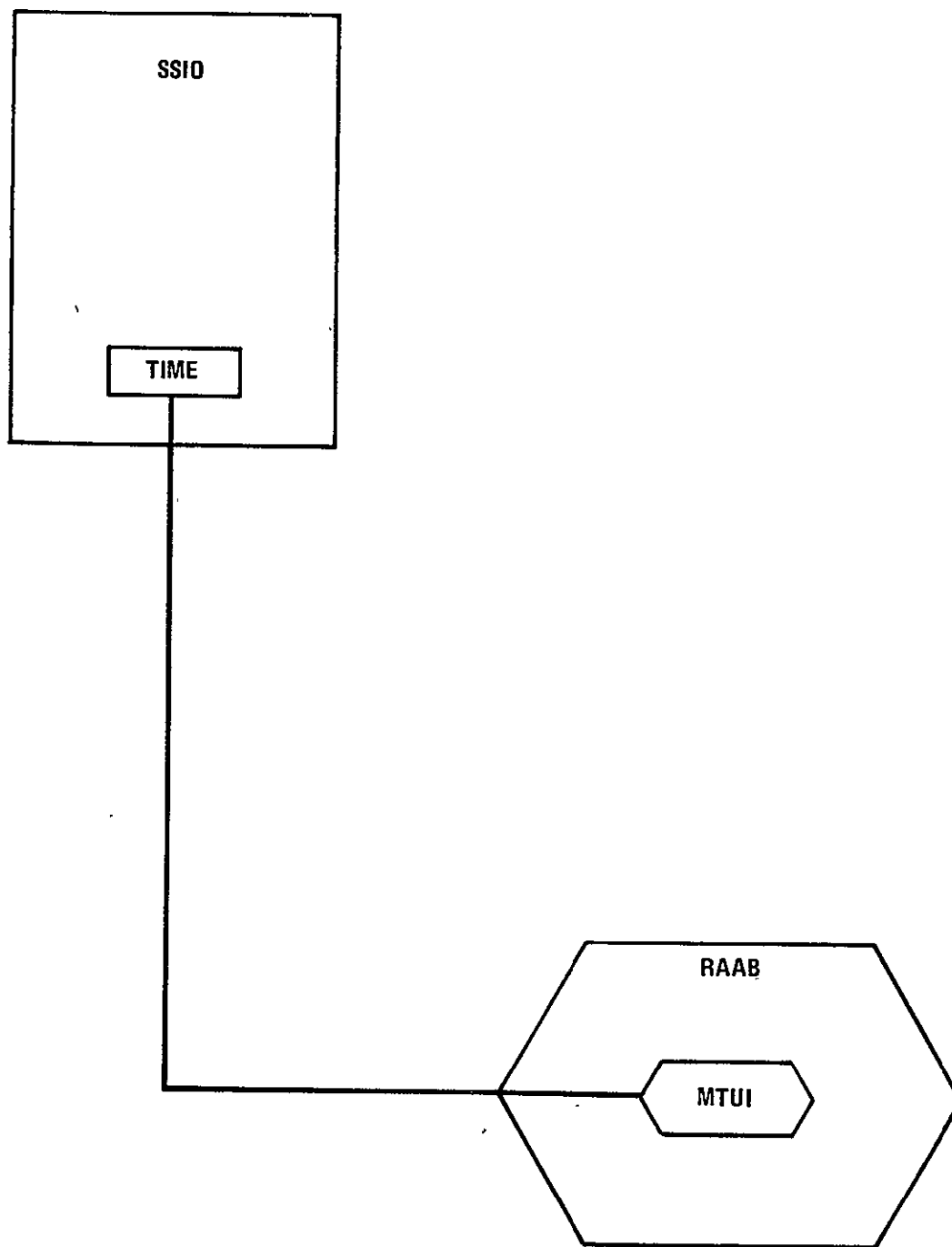

(y) 11,29.

Figure 6.- Continued.

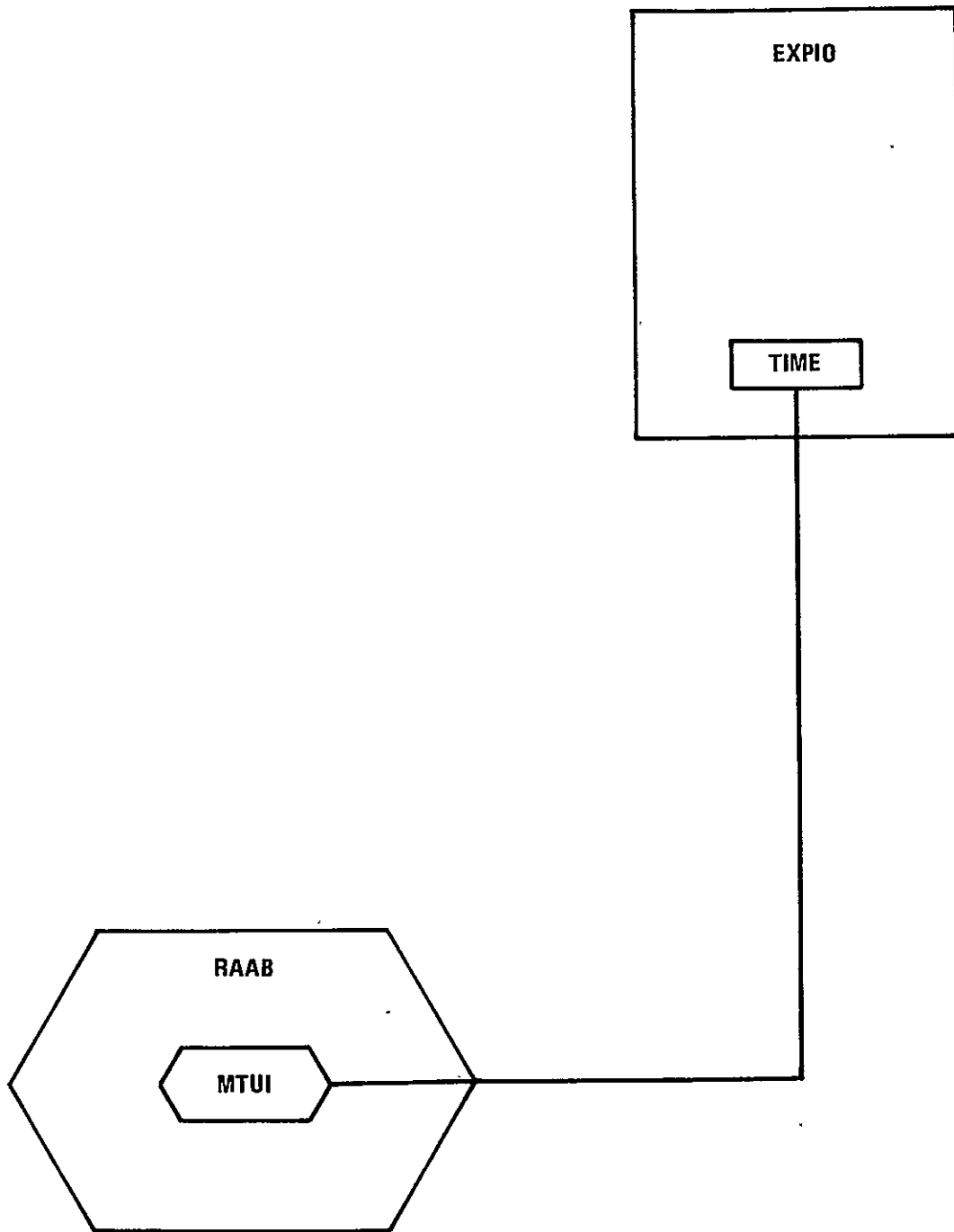

(z) 11,42.

Figure 6.- Continued.

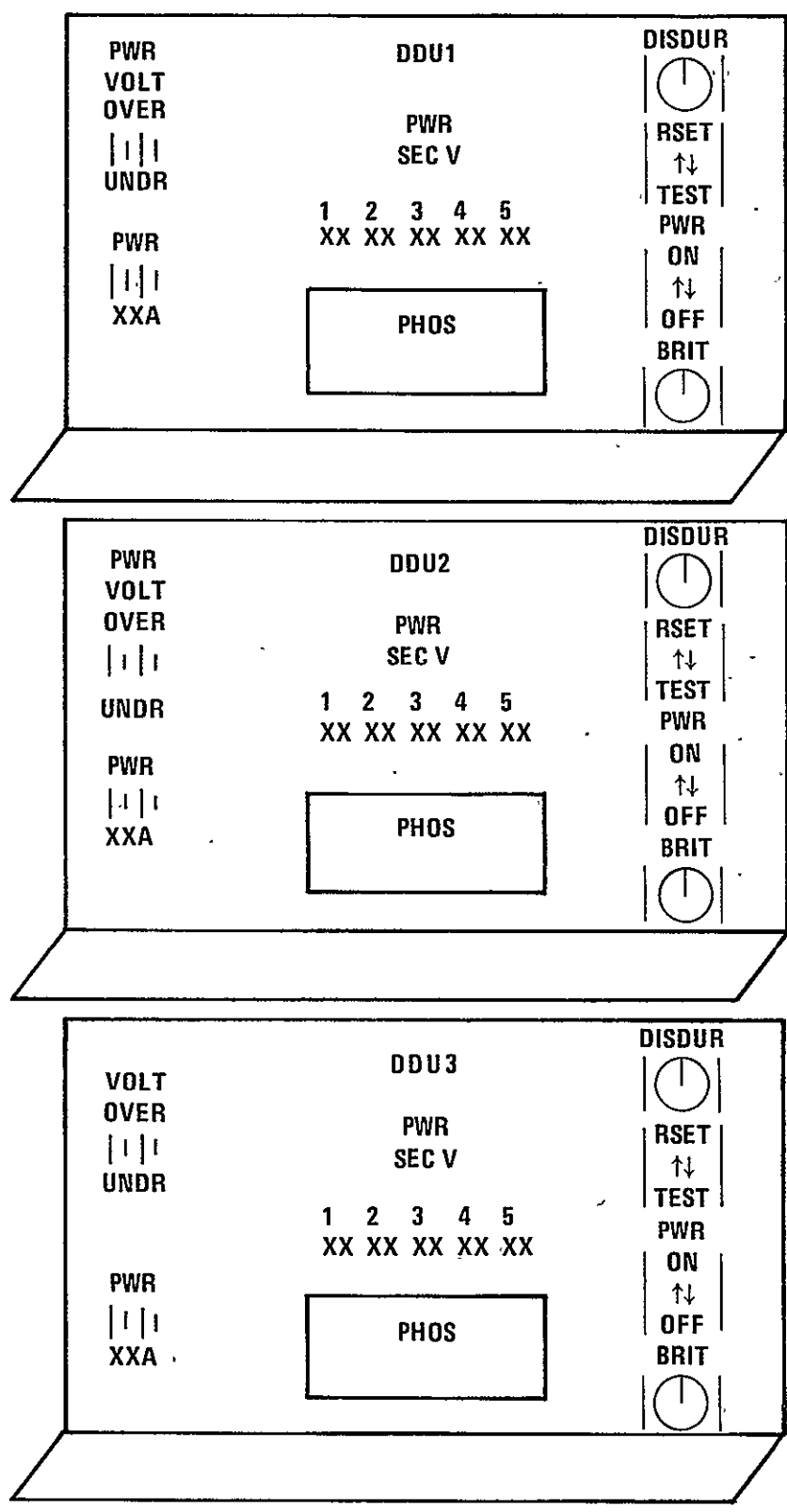

(a') 12,12.

Figure 6.- Continued.

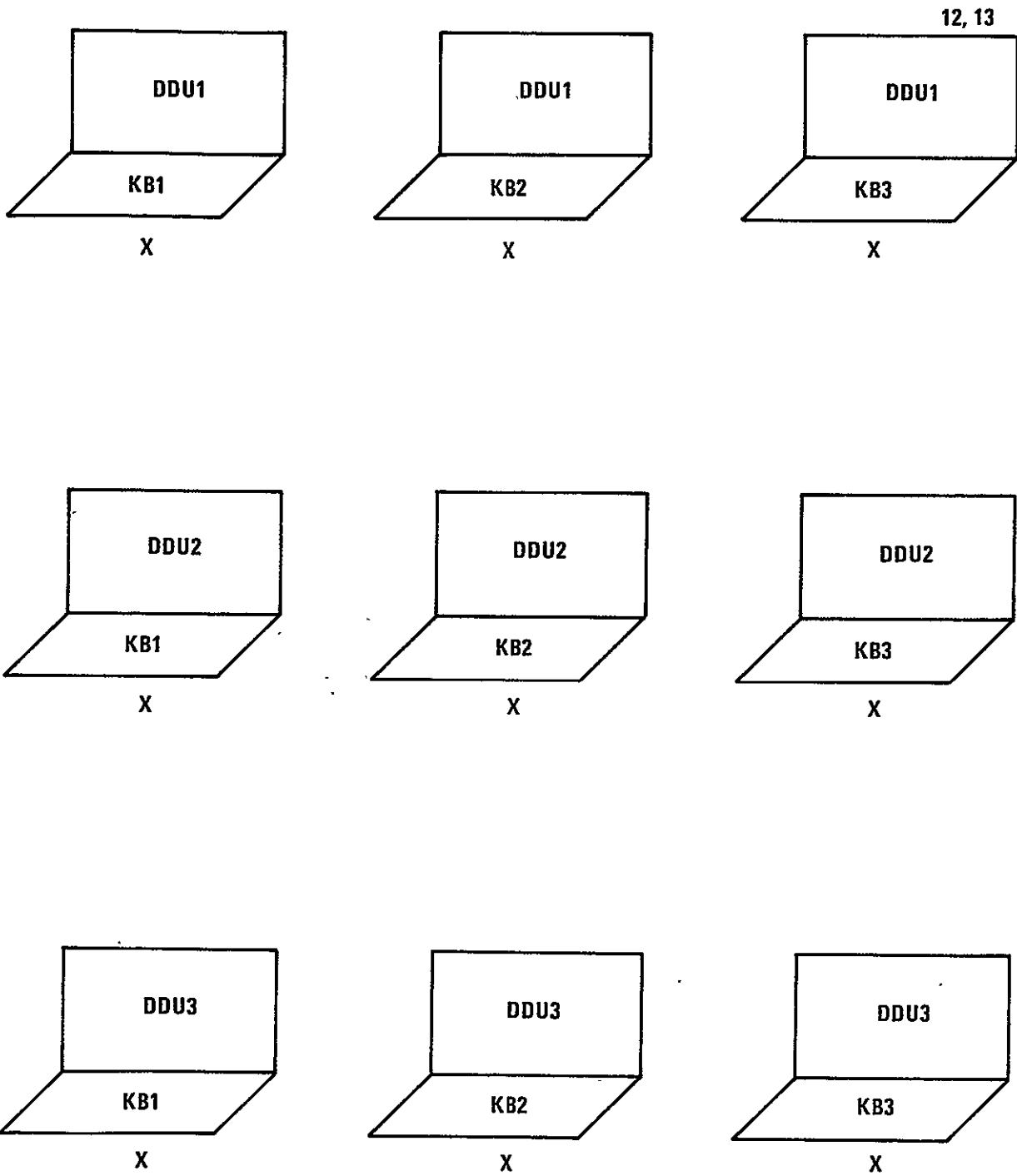

(b') 12,13.

Figure 6.- Continued.

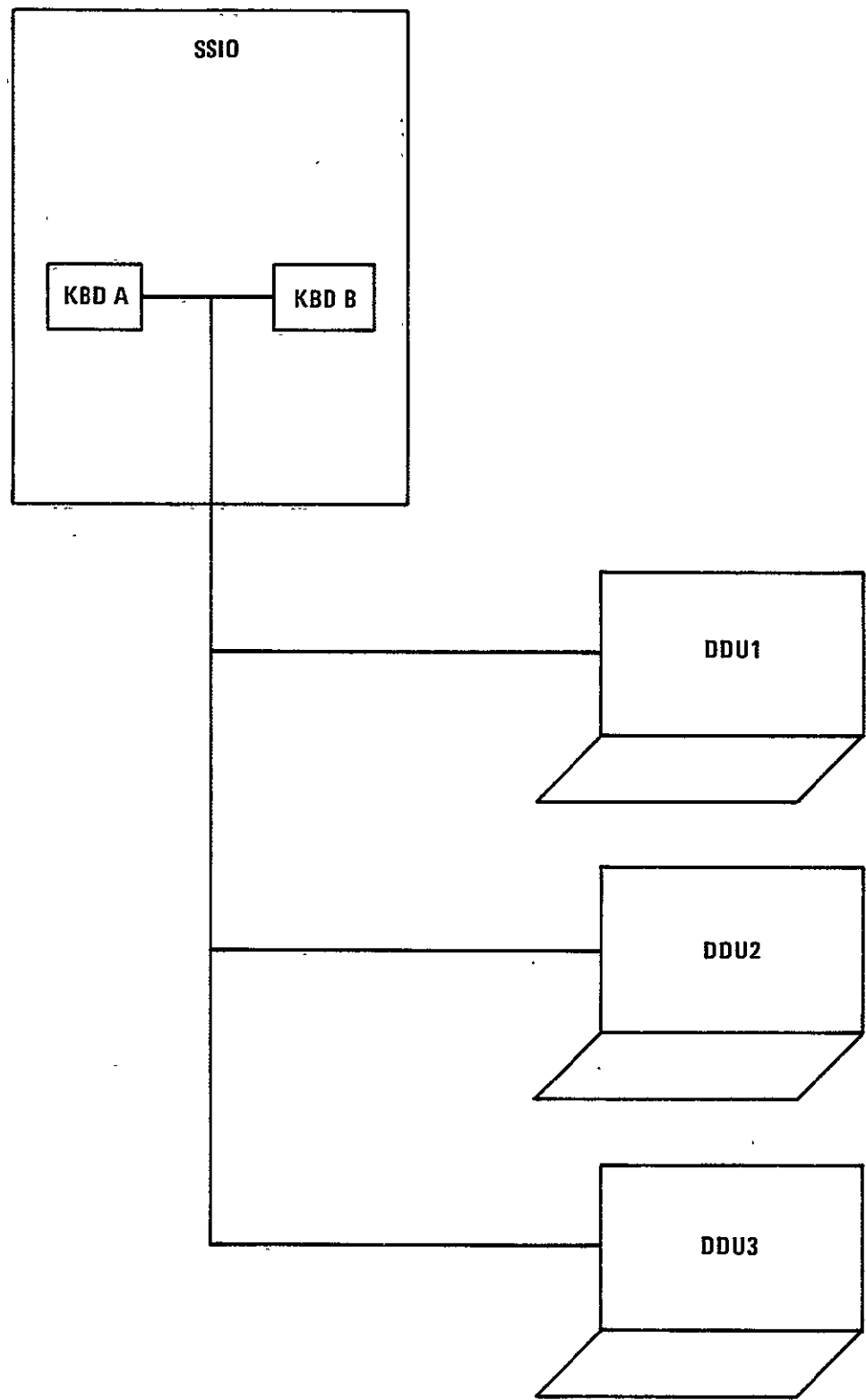

(c') 12,23.

Figure 6.- Continued.

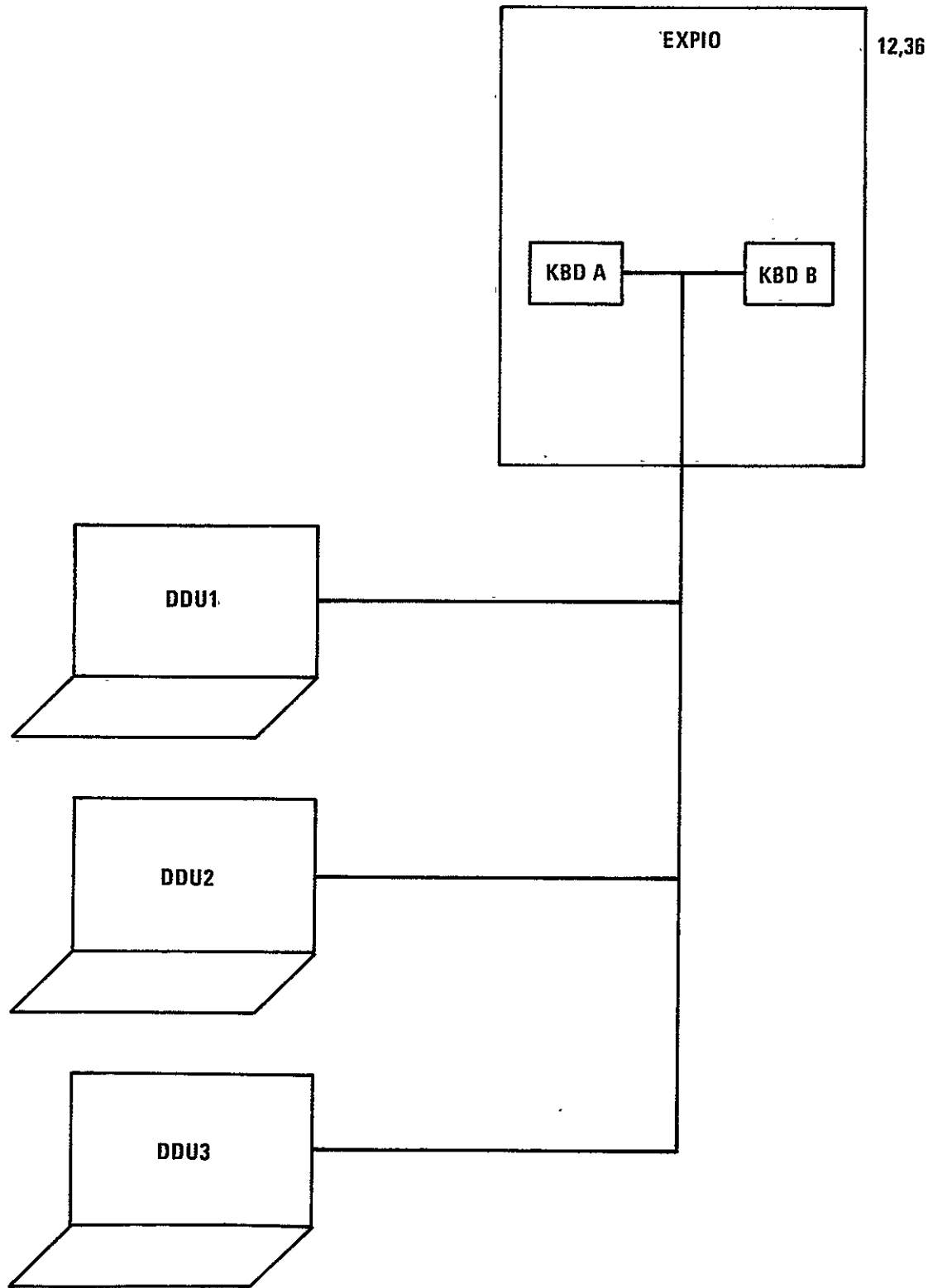

(d') 12,36.

Figure 6.- Continued.

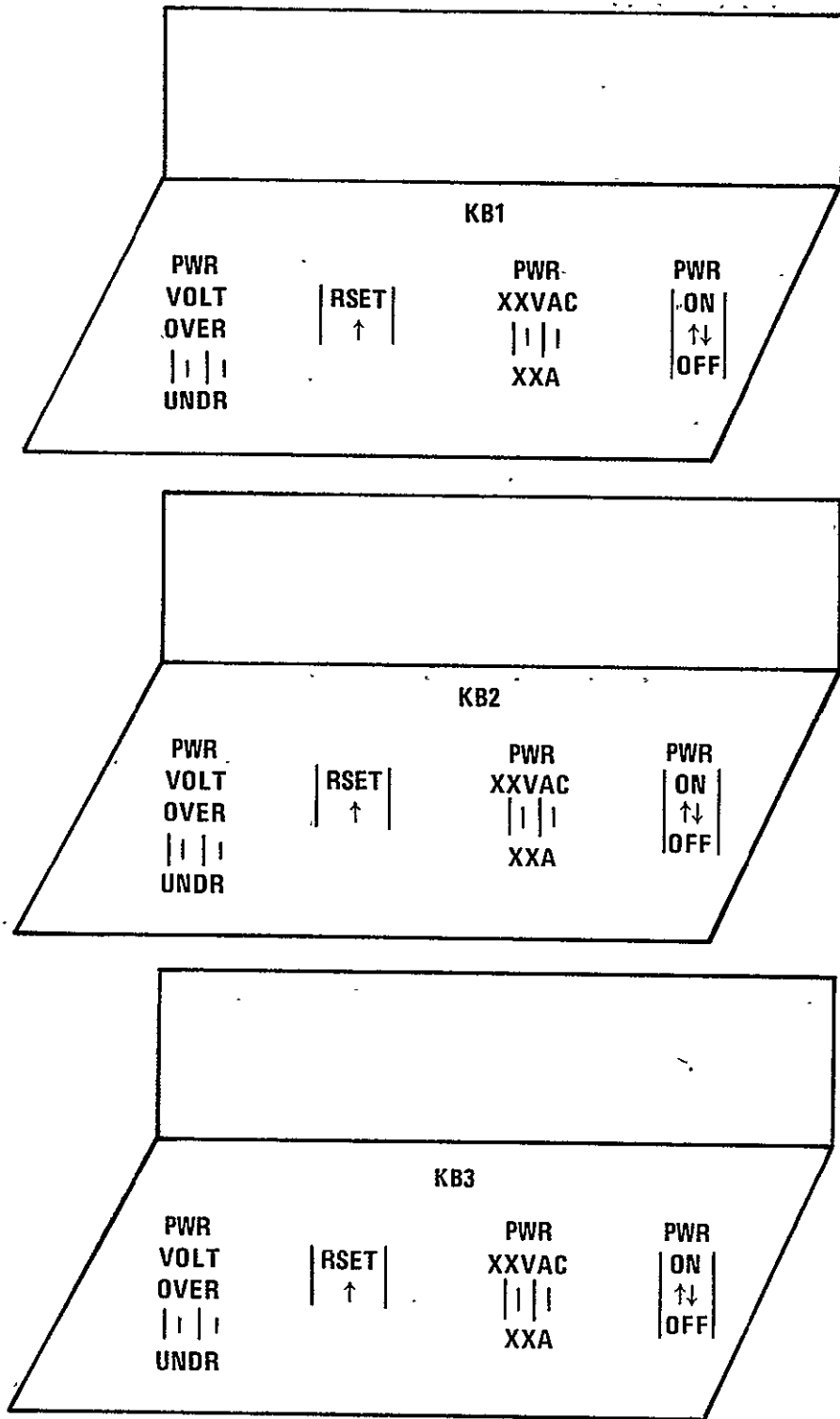

(e') 13,13.

Figure 6.- Continued.

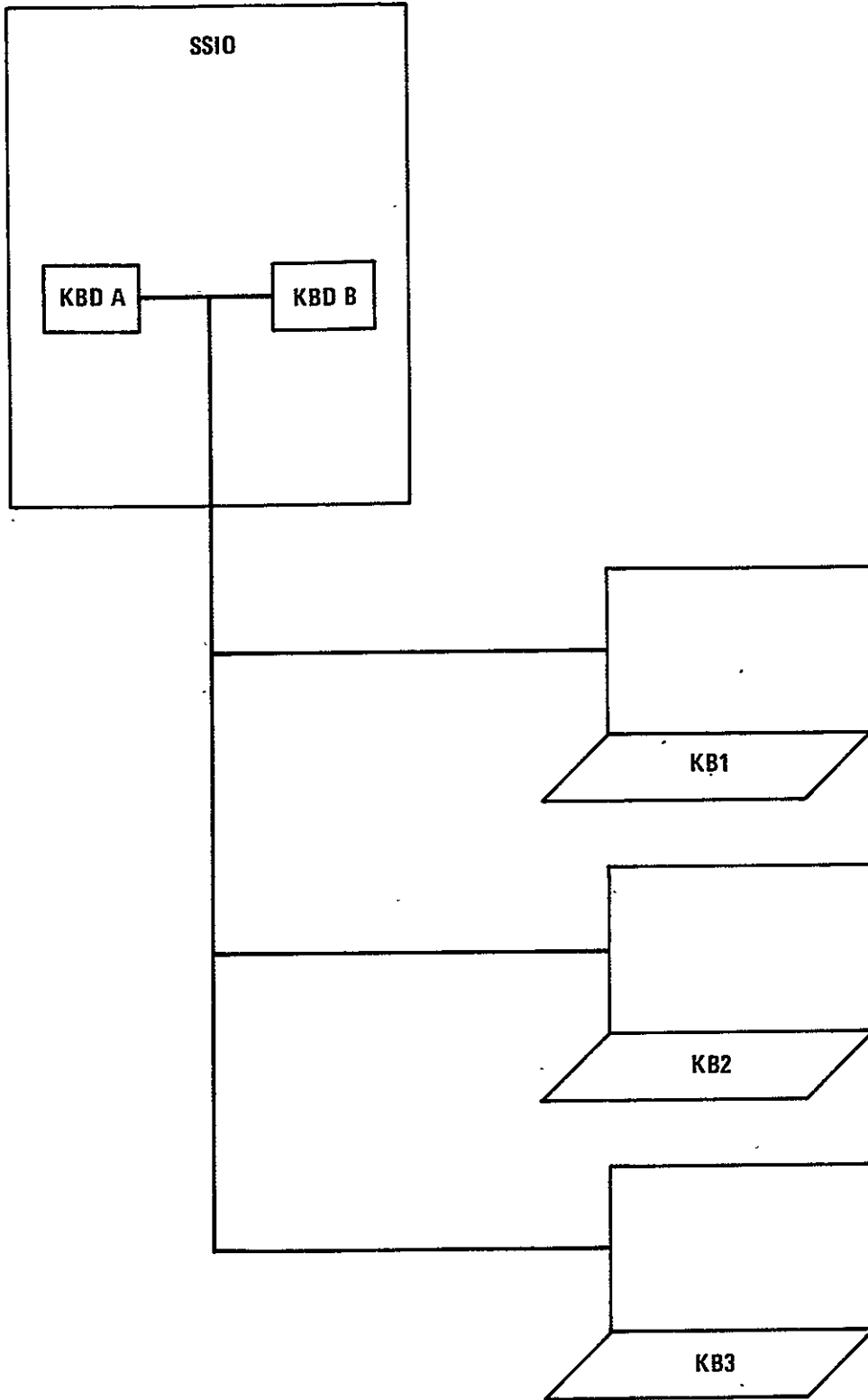

(f') 13,23.

Figure 6.- Continued.

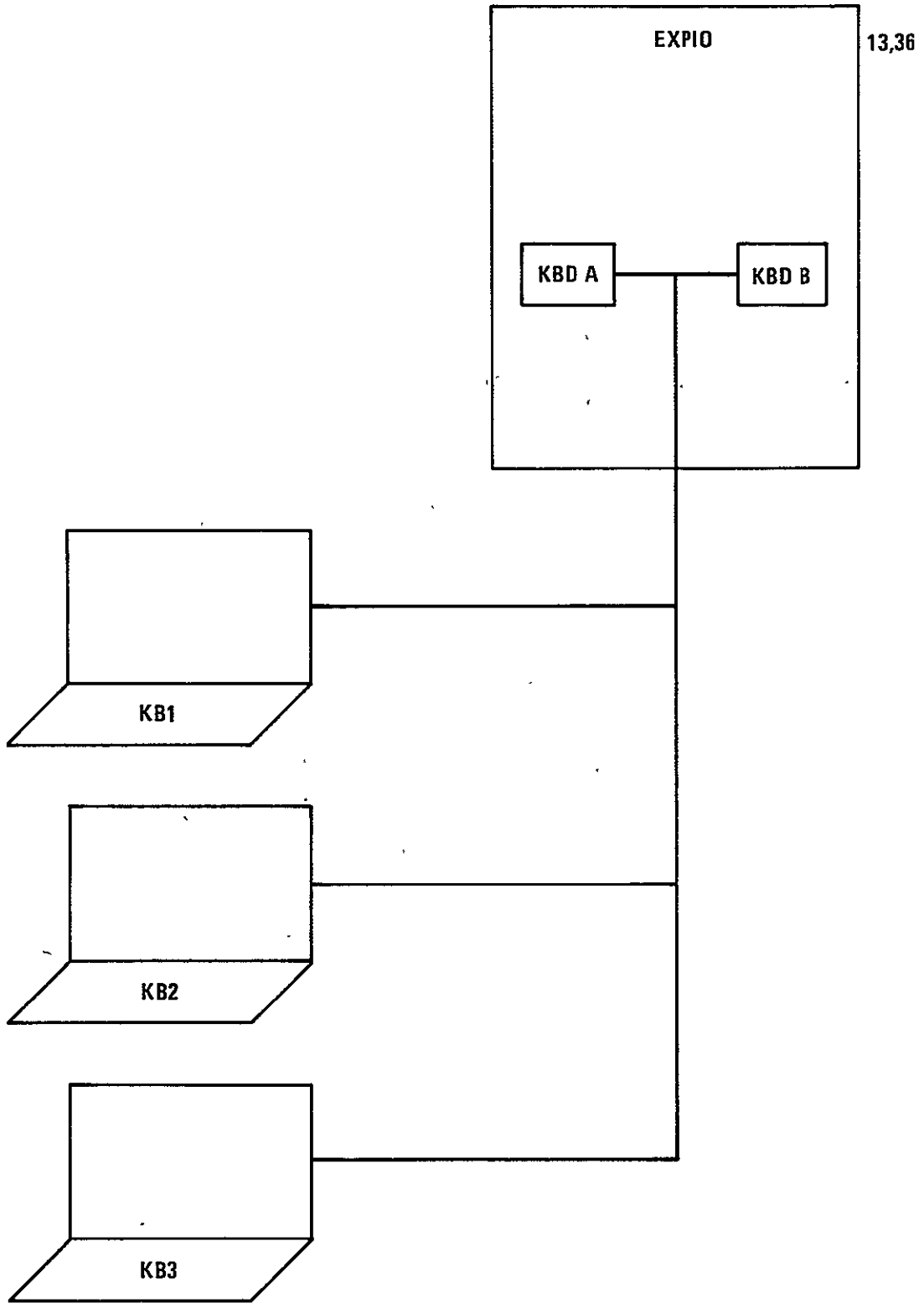

(g') 13,36.

Figure 6.- Continued.

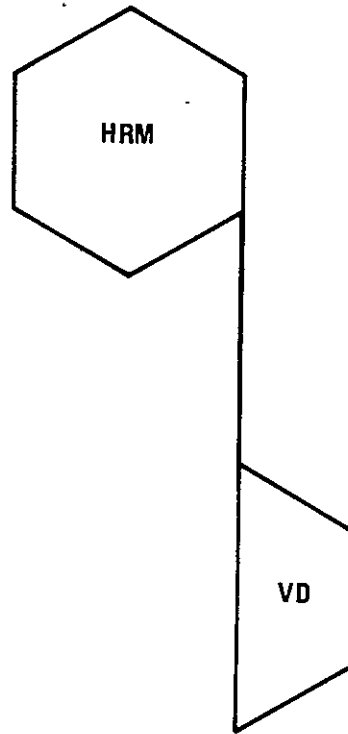

(h') 14,15.

Figure 6.- Continued.

14,16

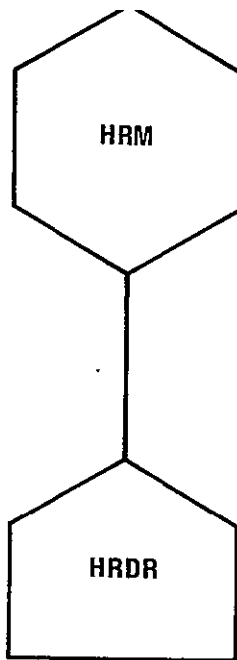

(i') 14,16.

Figure 6.- Continued.

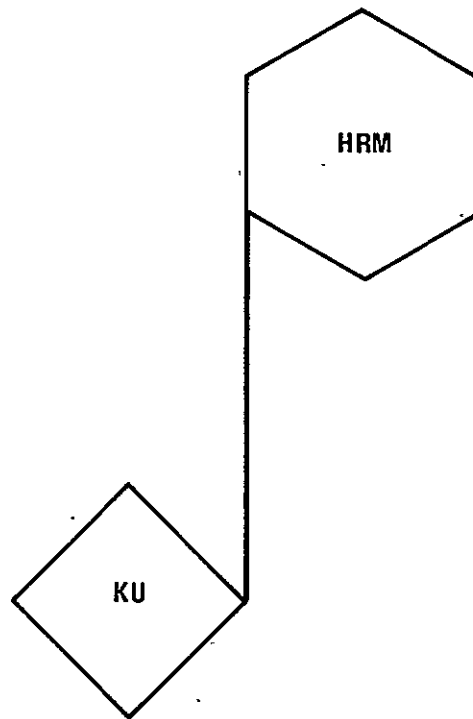

(j') 14,20.

Figure 6.- Continued.

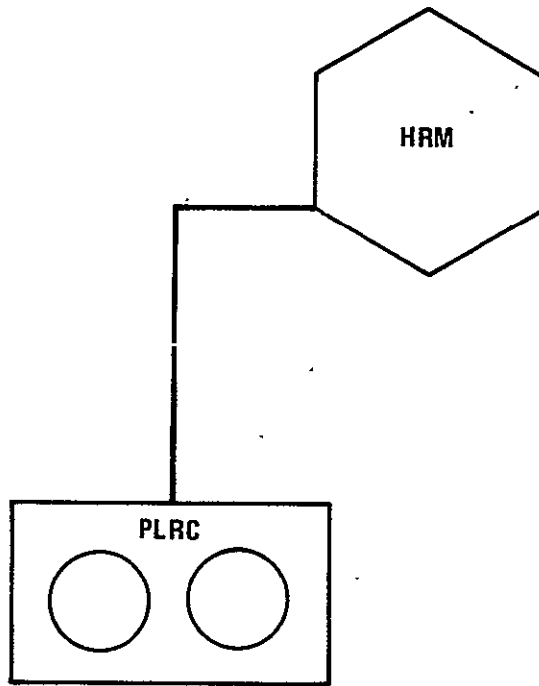

(k') 14,22.

Figure 6.- Continued.

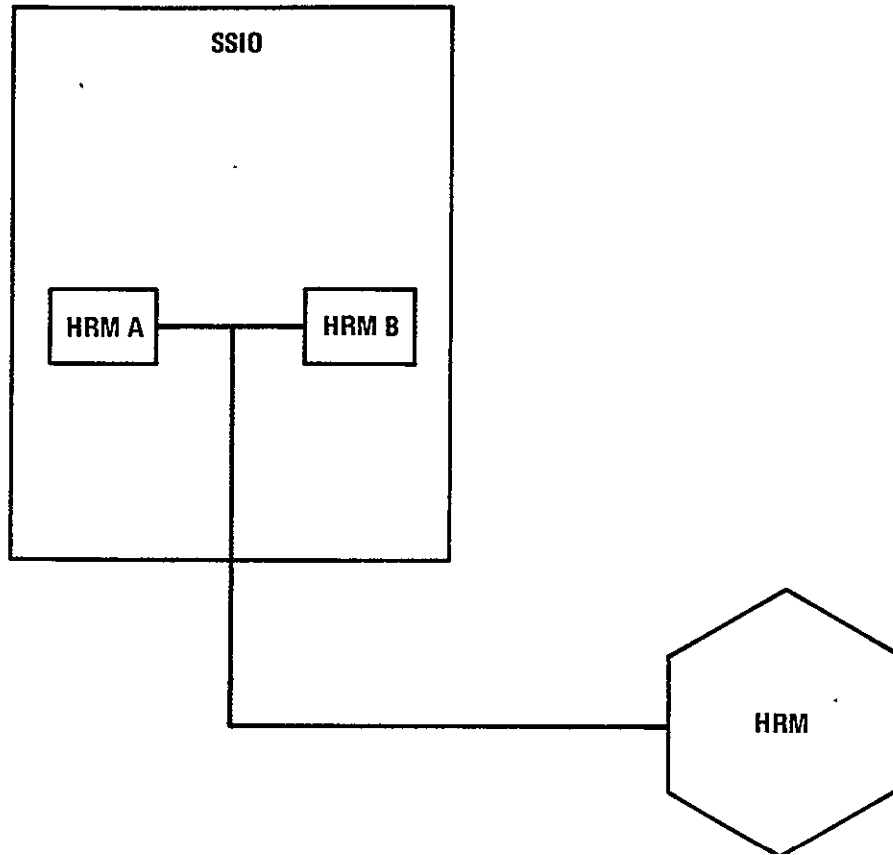

(1') 14,28.

Figure 6.- Continued.

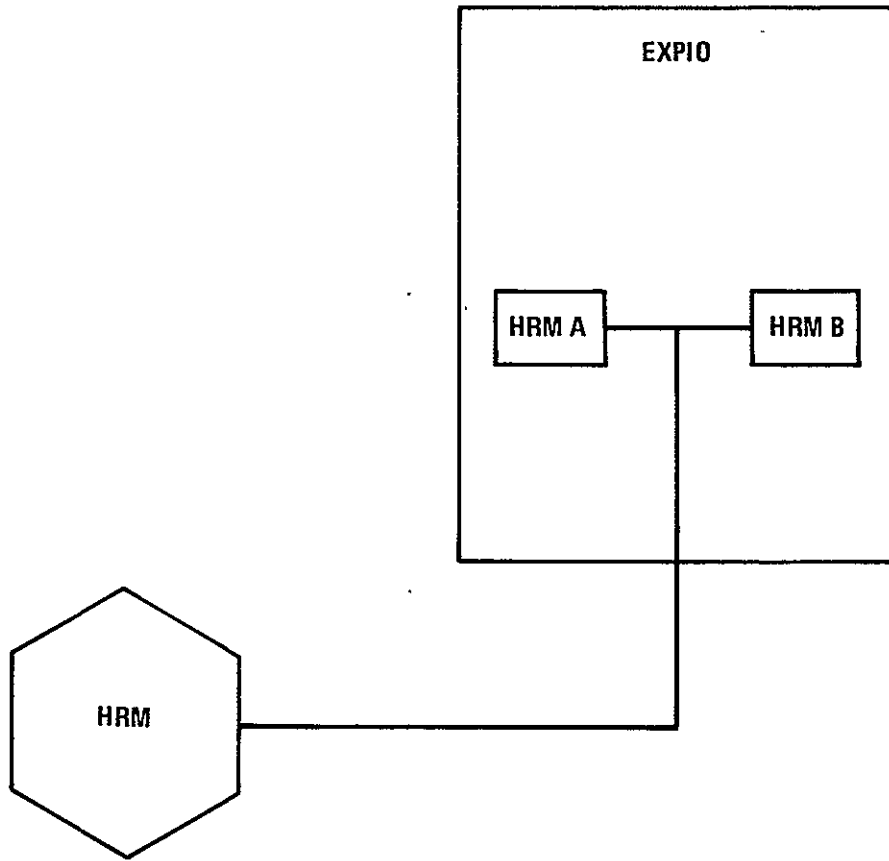

(m') 14,41.

Figure 6.- Continued.

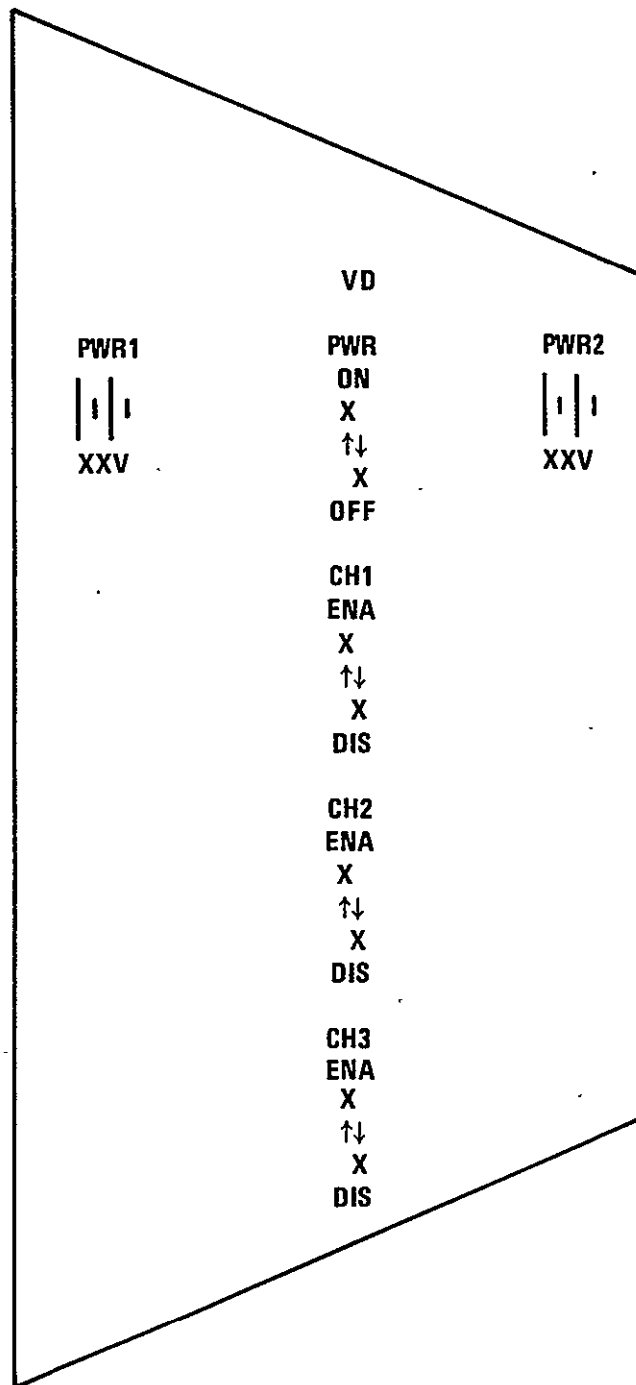

(n') 15,15.

Figure 6.- Continued.

15,17



(o') 15,17. .

Figure 6.- Continued.

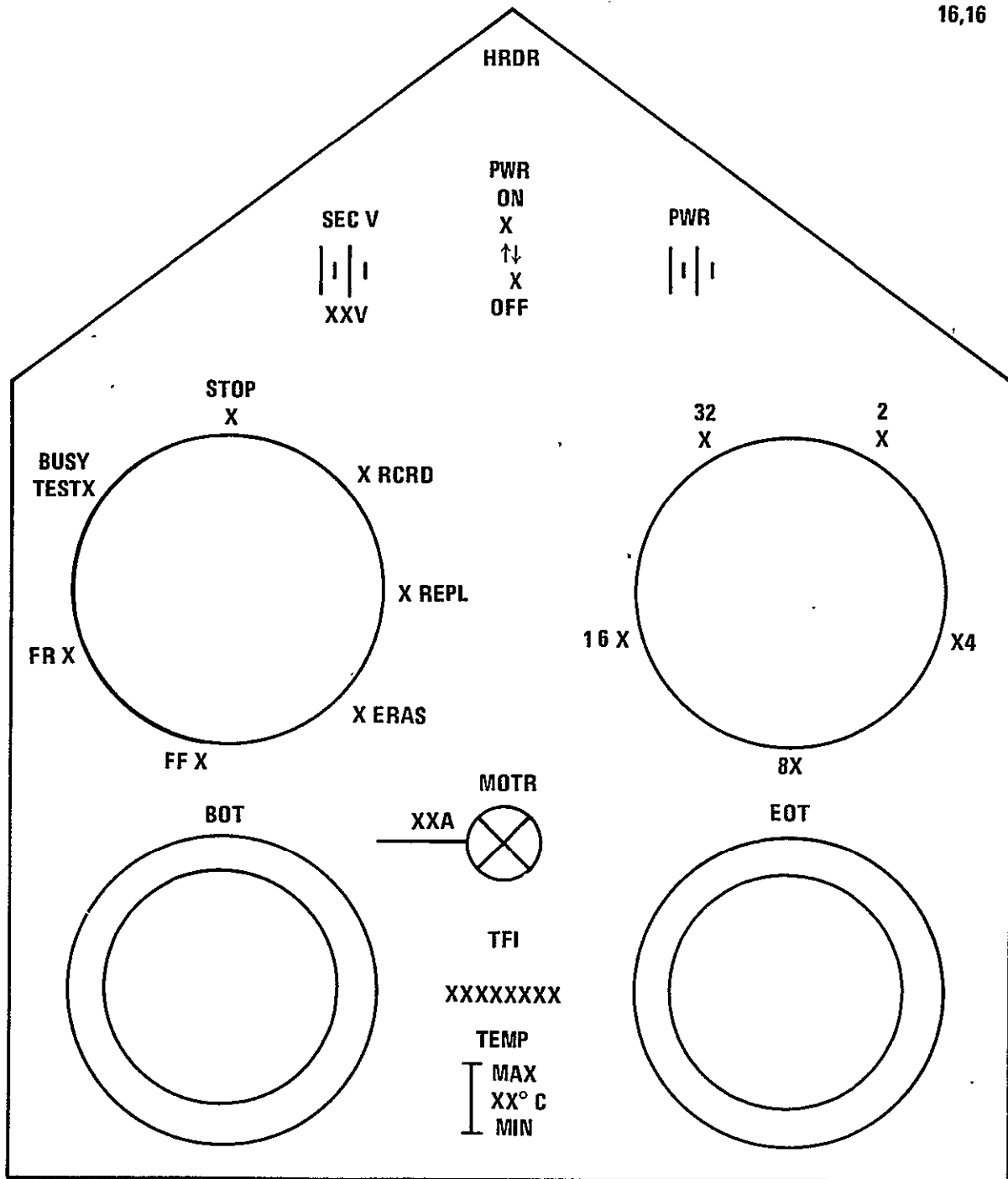

(p') 16,16.

Figure 6.- Continued.

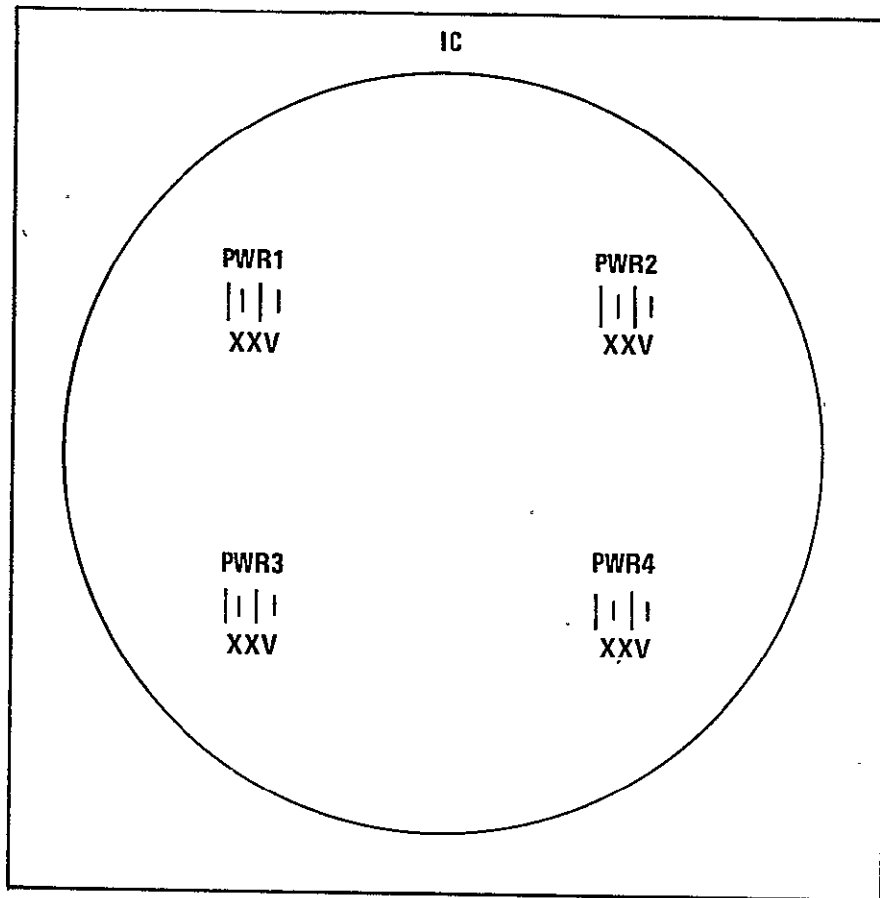

(q') 17,17.

Figure 6.- Continued.

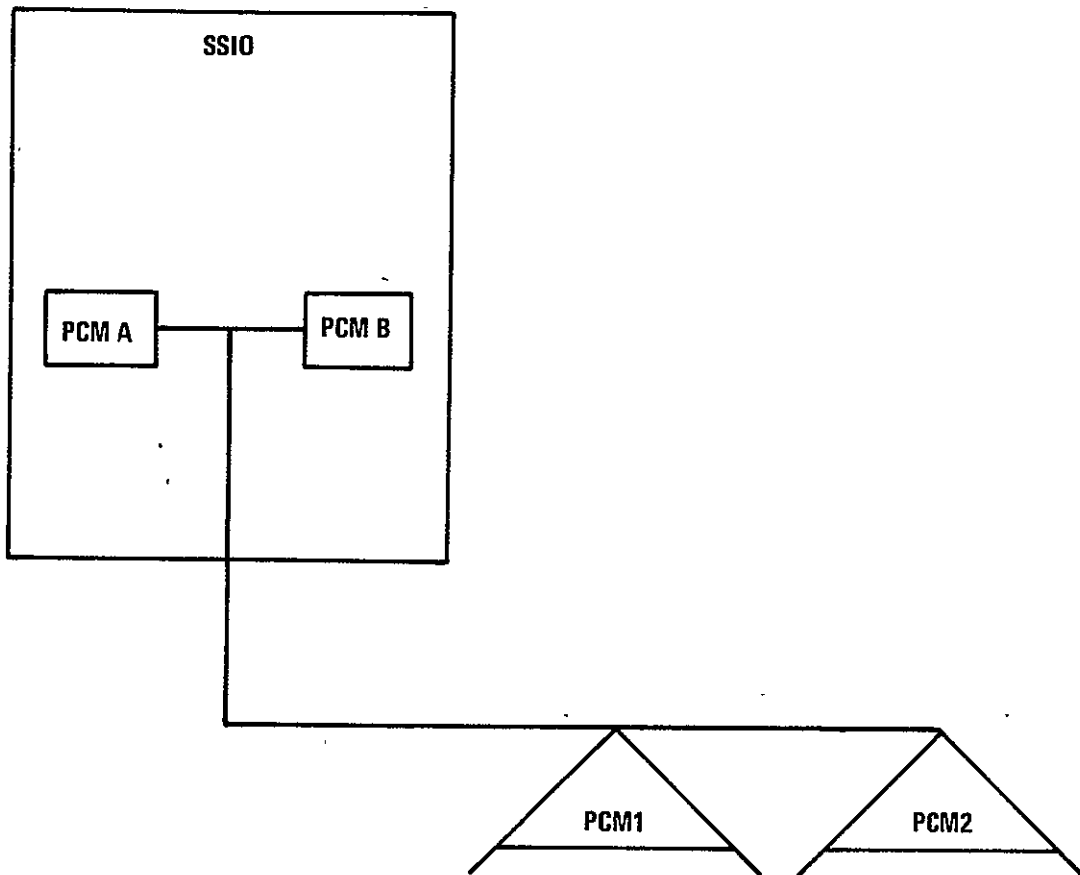

(r') 18,26.

Figure 6.- Continued.

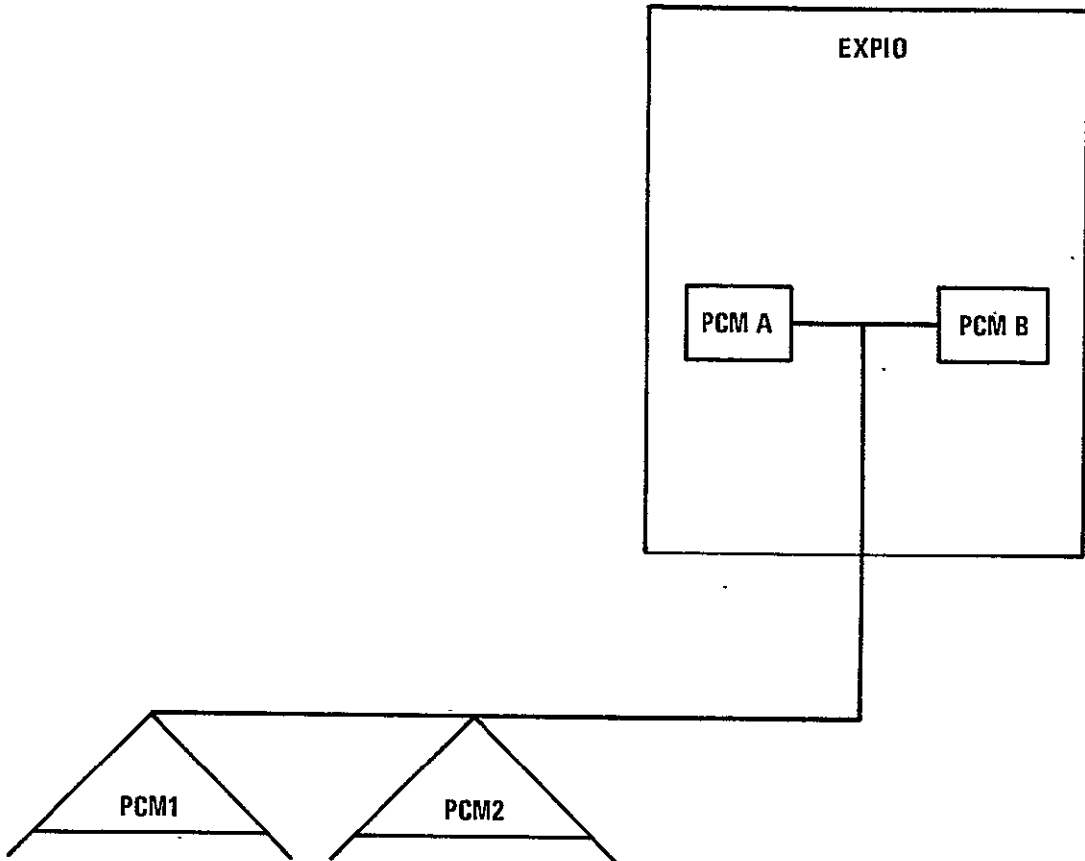

(s') 18,39.

Figure 6.- Continued.

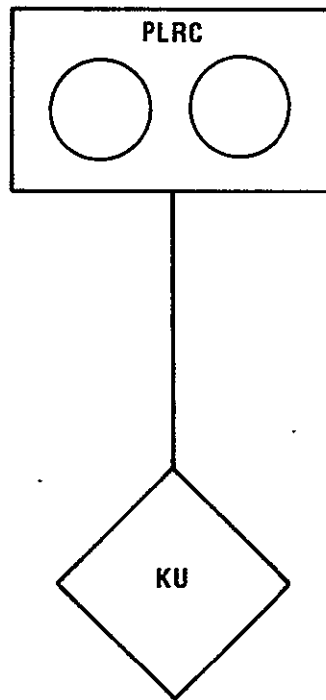

(t') 20,22.

Figure 6.- Continued.

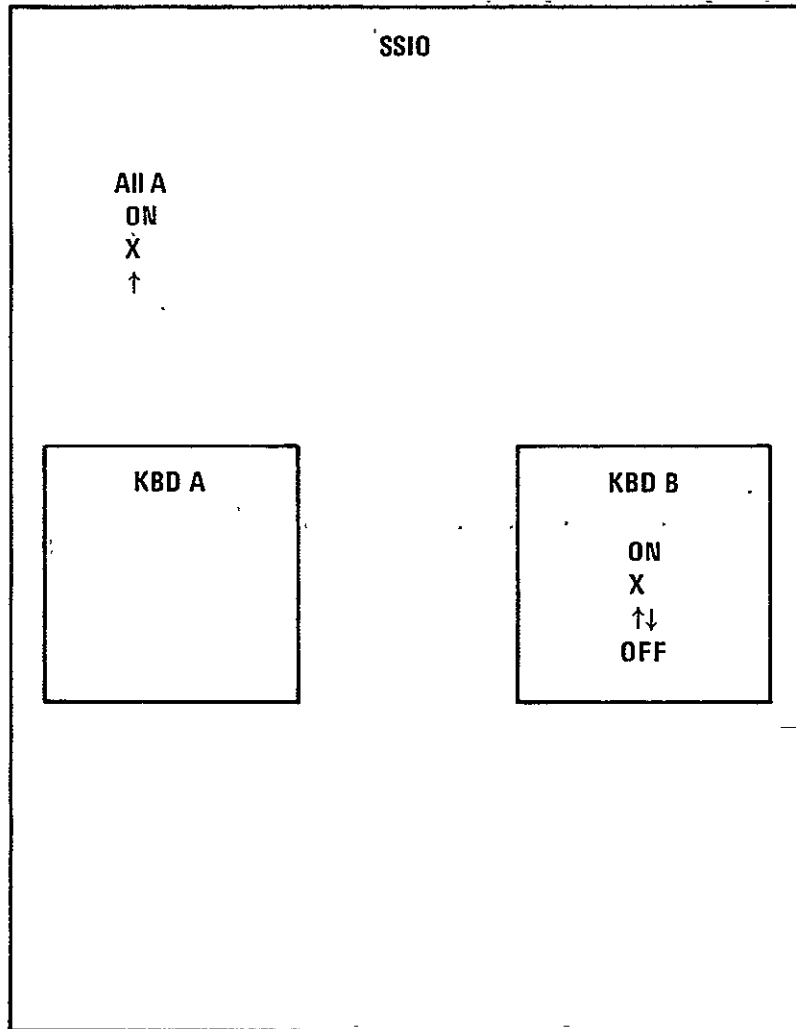

(u') 23,23.

Figure 6.- Continued.

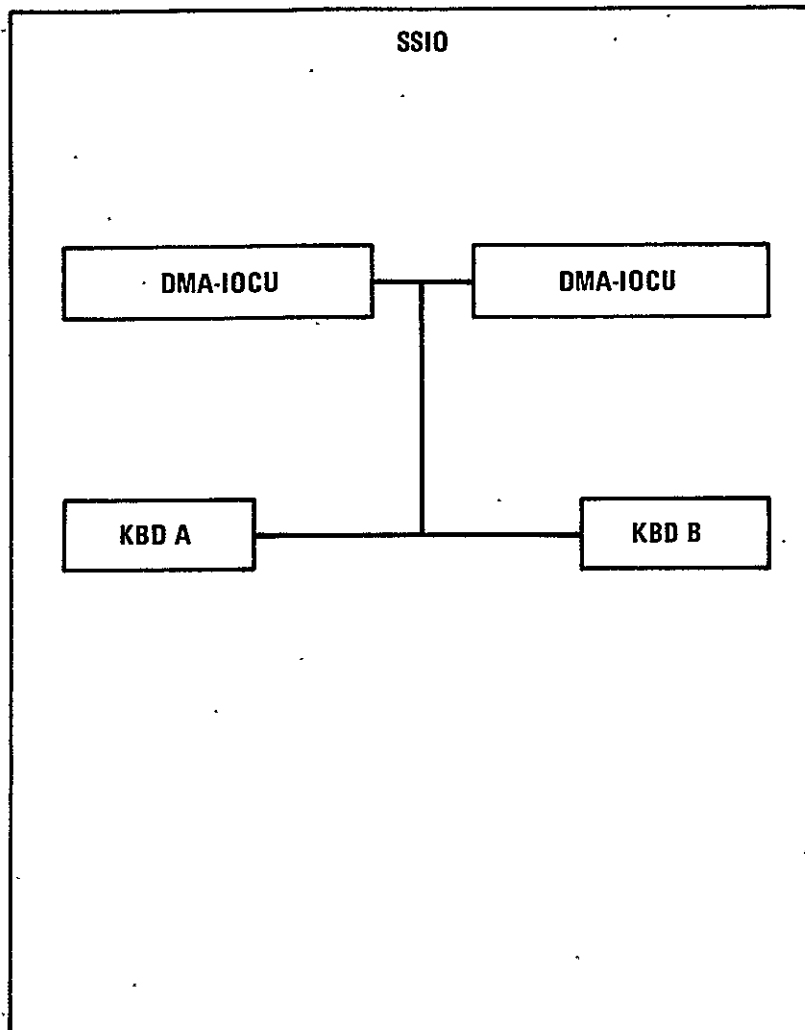

(v') 23,30.

Figure 6.- Continued.

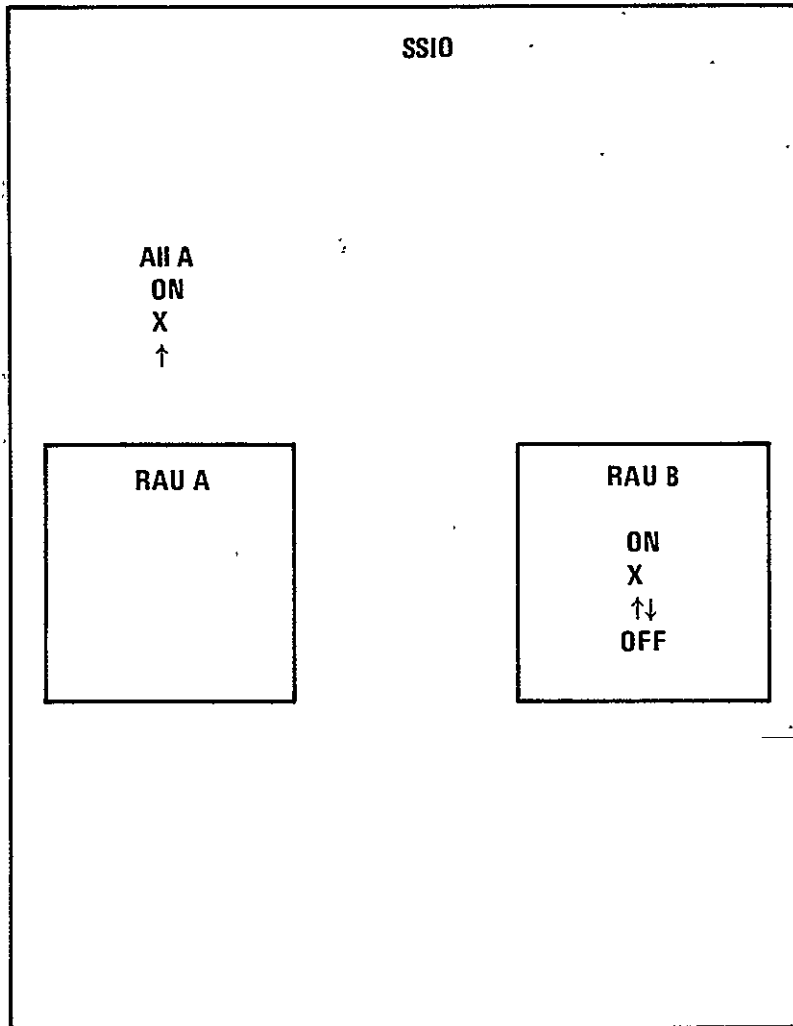

(w') 24,24.

Figure 6.- Continued.

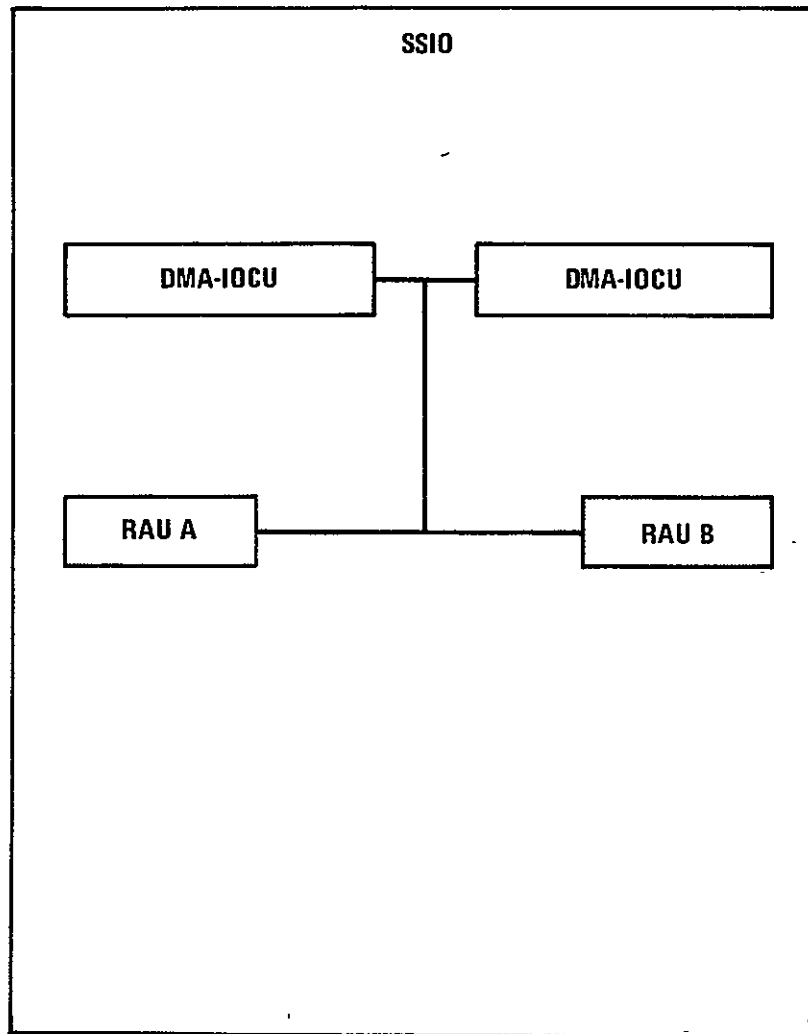

(x') 24,30.

Figure 6.- Continued.

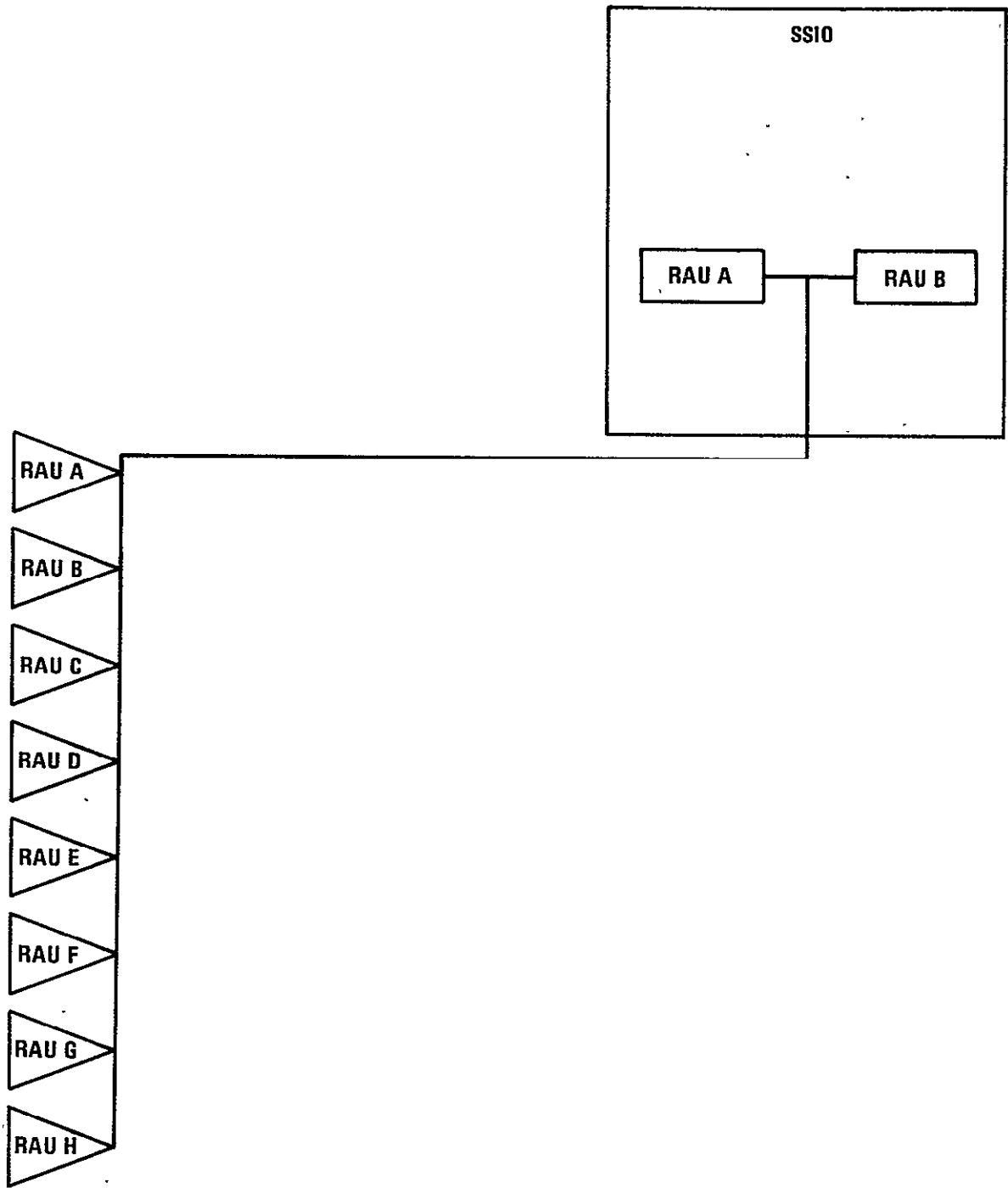

(y') 24,32.

Figure 6.- Continued.

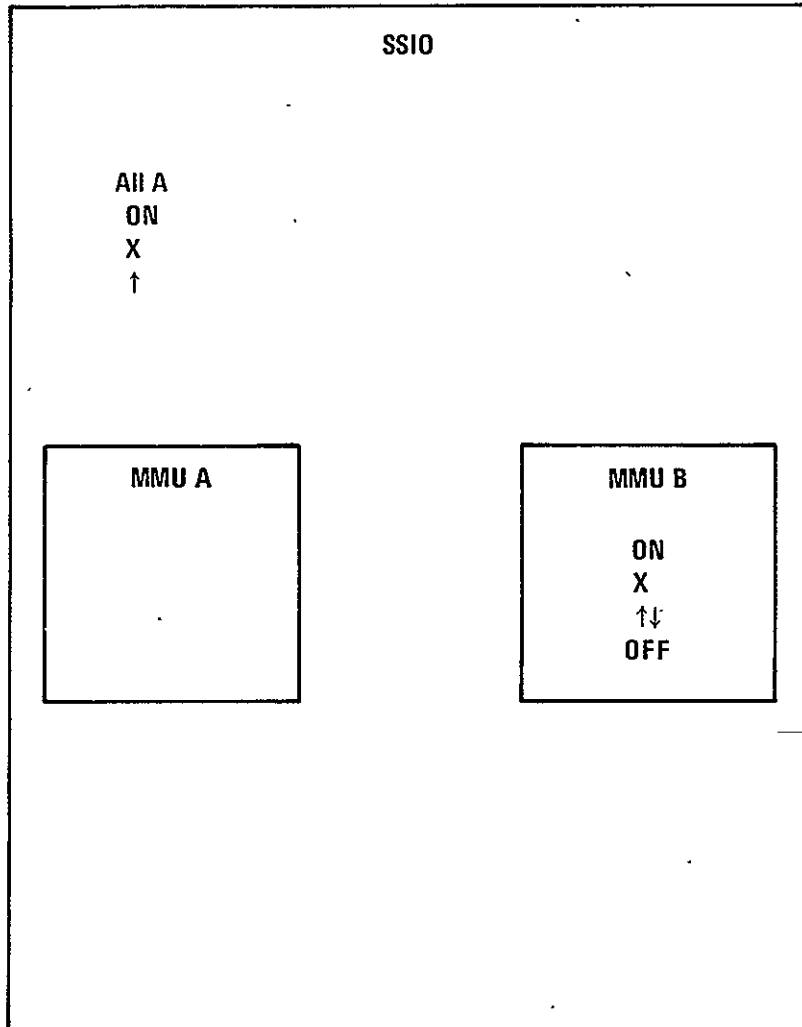

(z') 25,25.

Figure 6.- Continued.

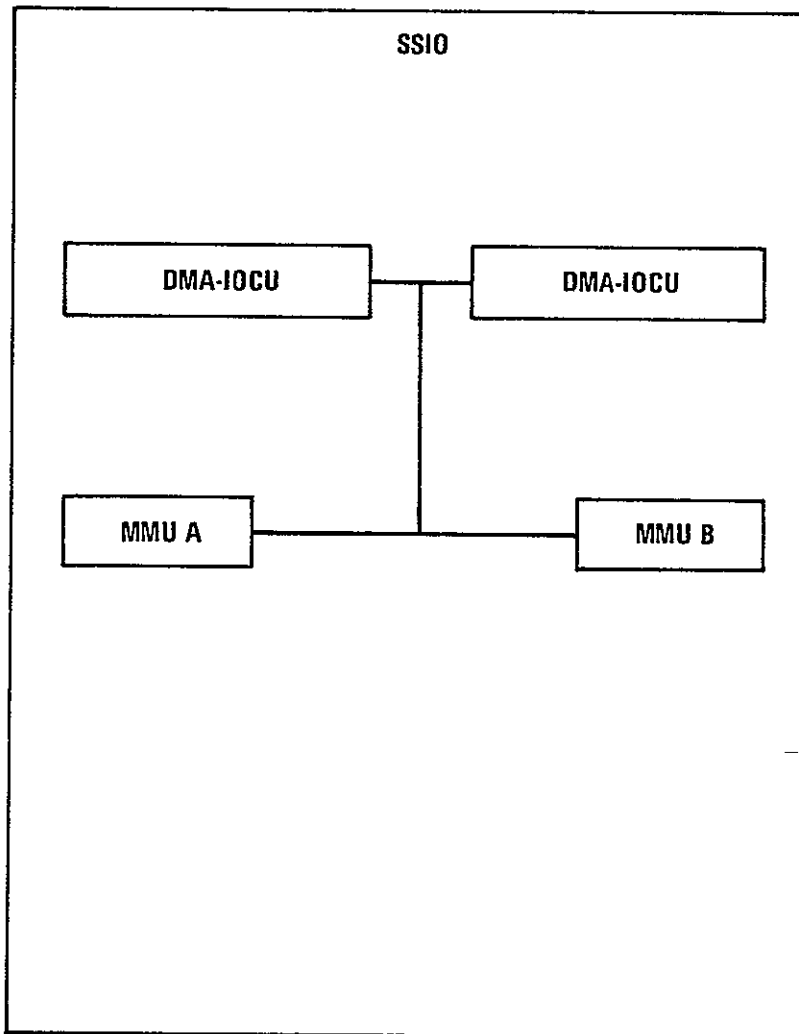

(a'') 25,30.

Figure 6.- Continued.

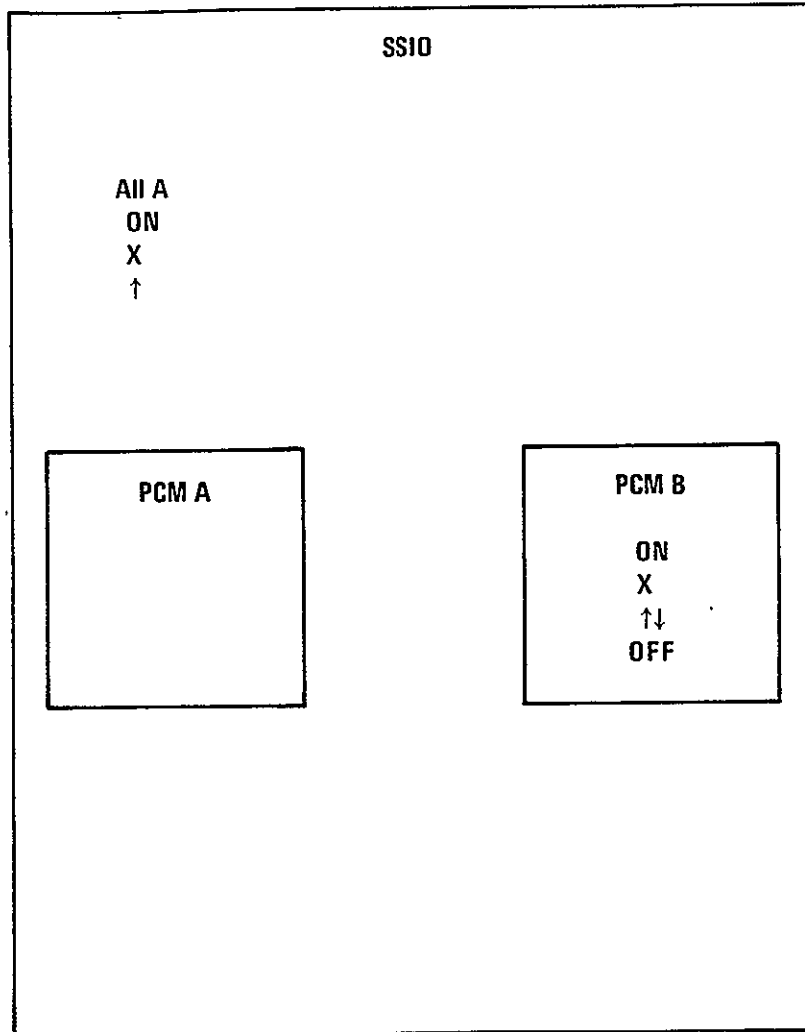

(b'') 26,26.

Figure 6.- Continued.

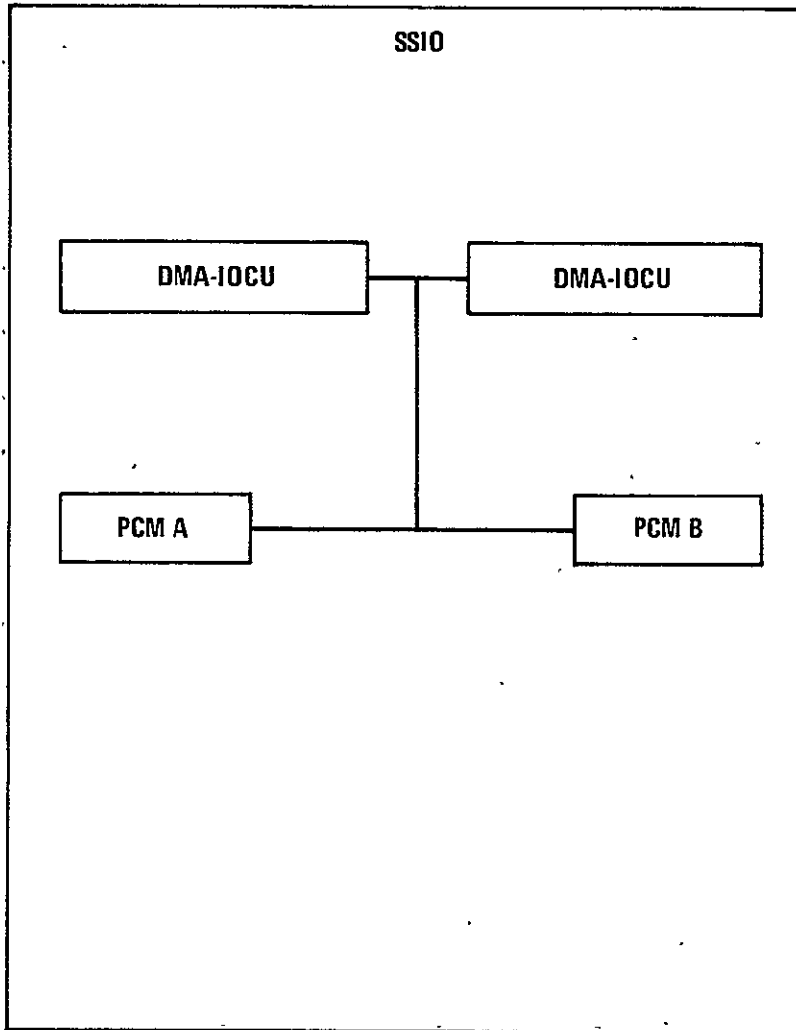

(c'') 26,30.

Figure 6.- Continued.

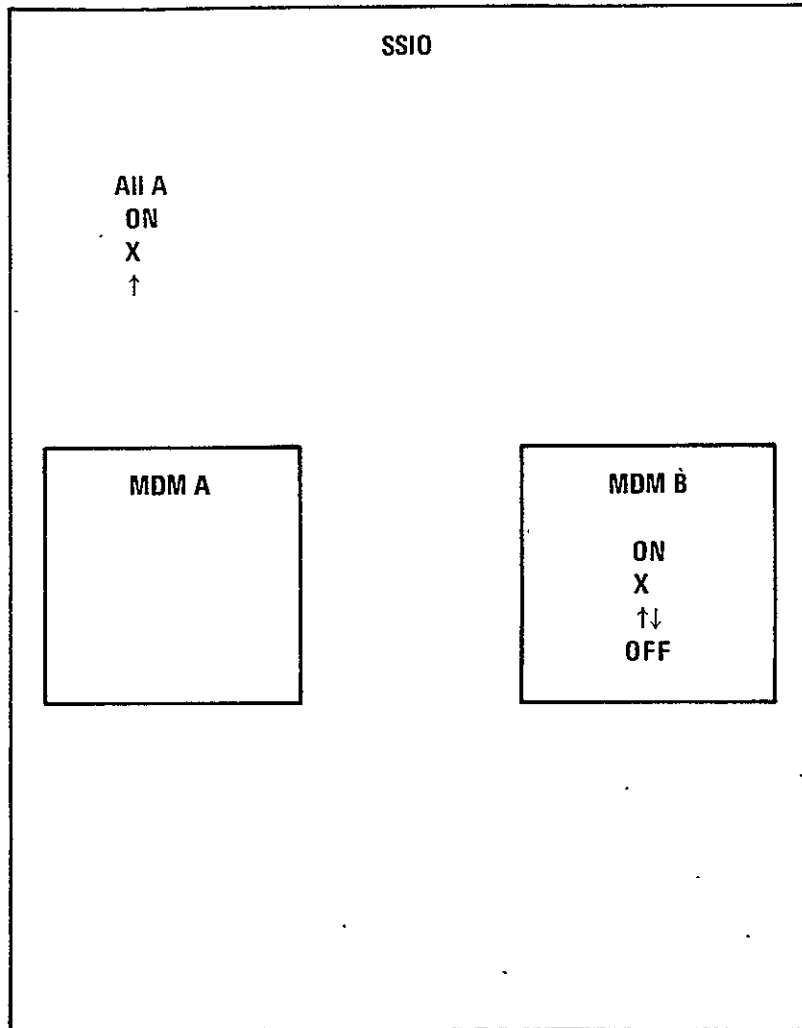

(d'') 27,27.

Figure 6.- Continued.

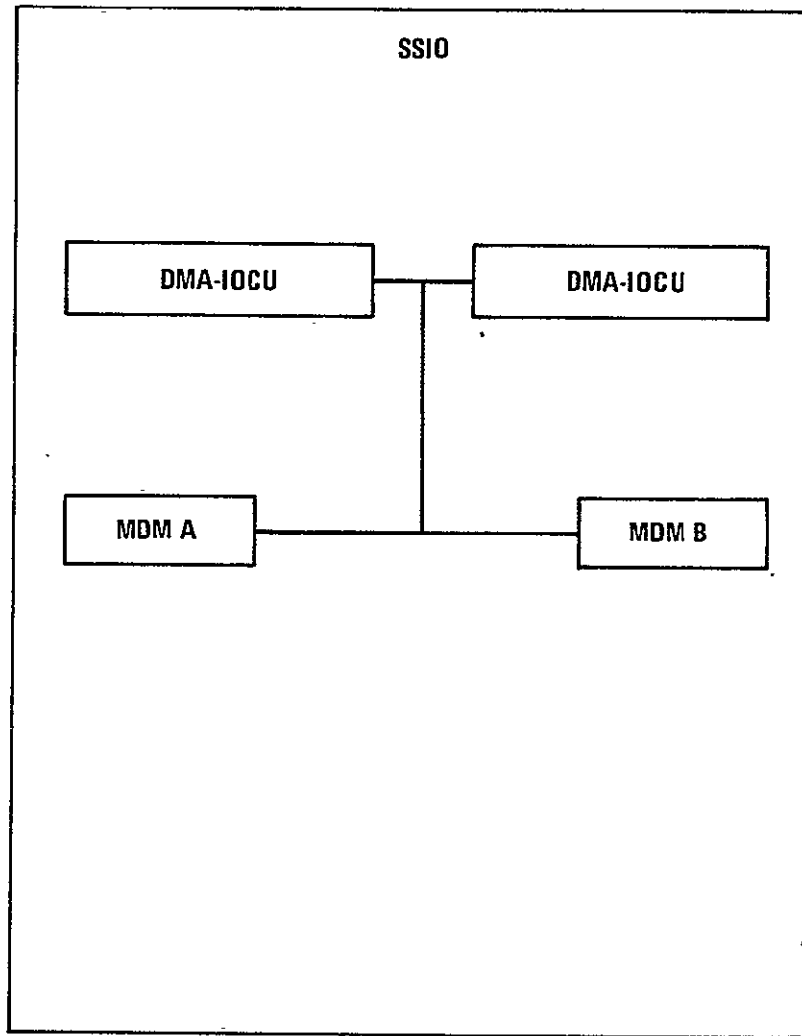

(e'') 27,30.

Figure 6.- Continued.

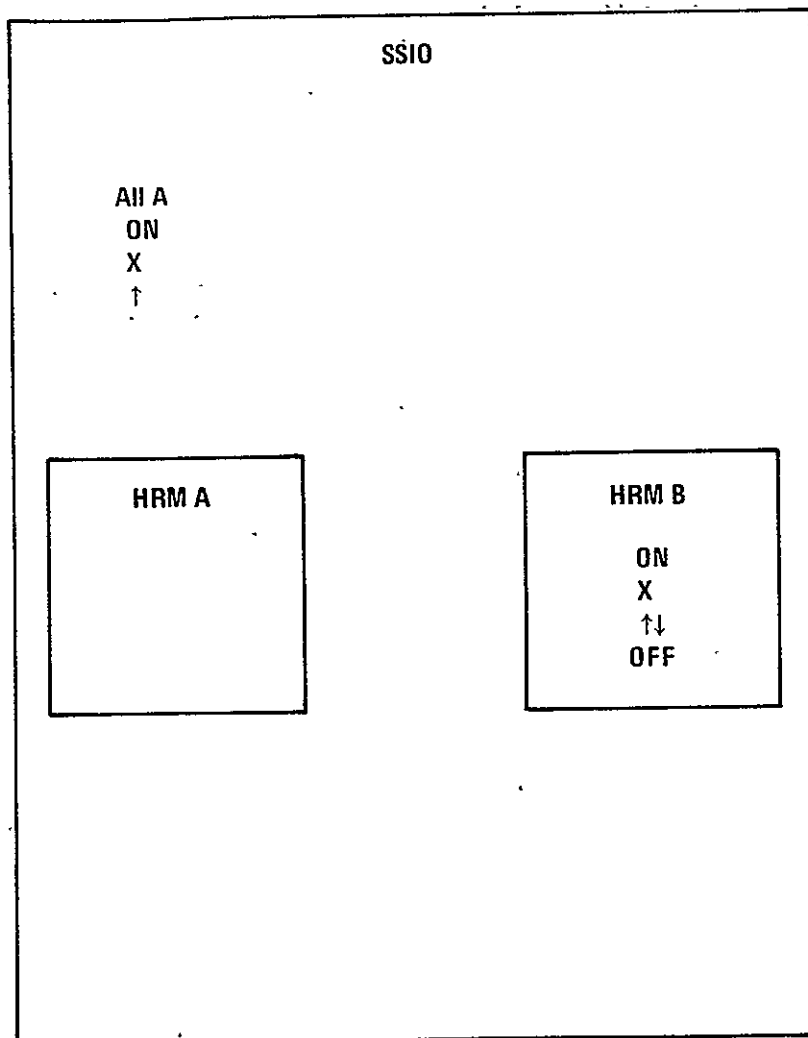

(f'') 28,28.

Figure 6.- Continued.

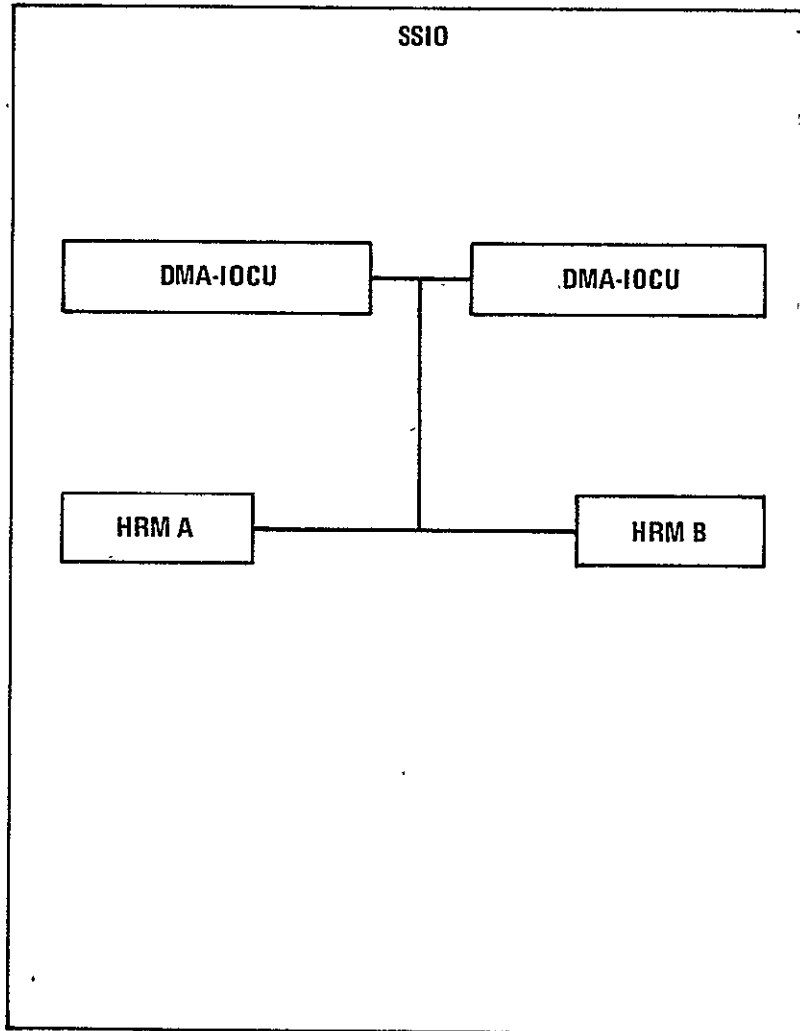

(g'') 28,30.

Figure 6.- Continued.

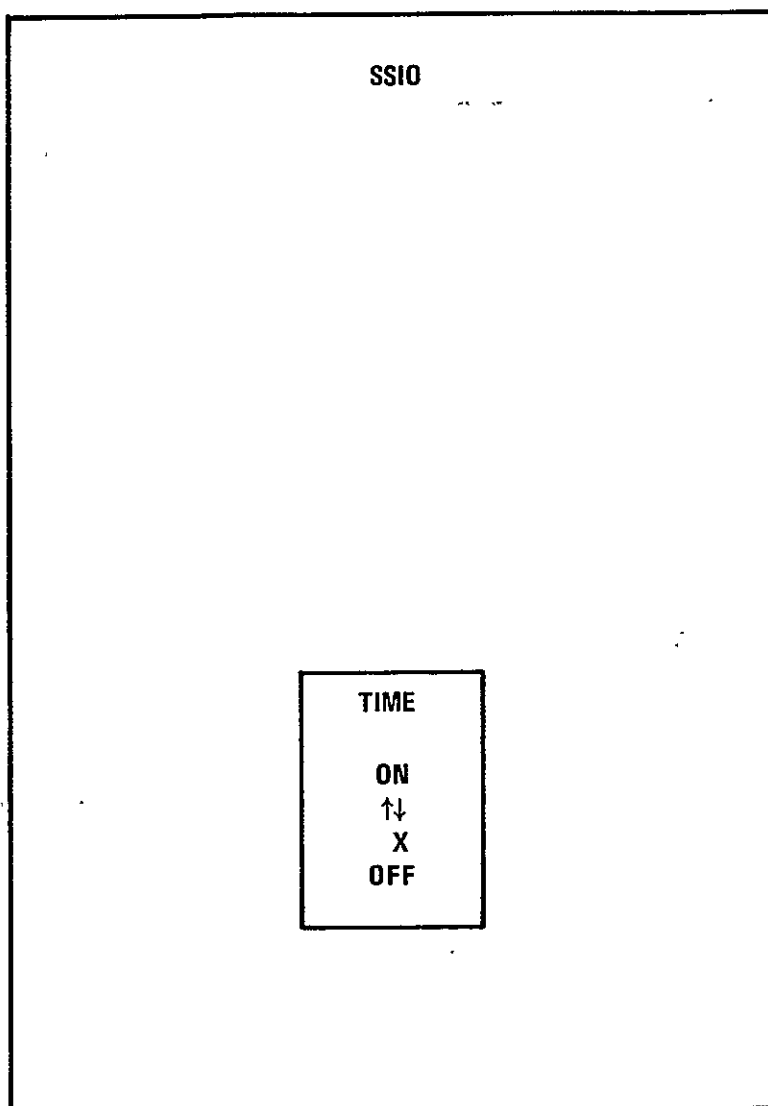

(h'') 29,29.

Figure 6.- Continued.

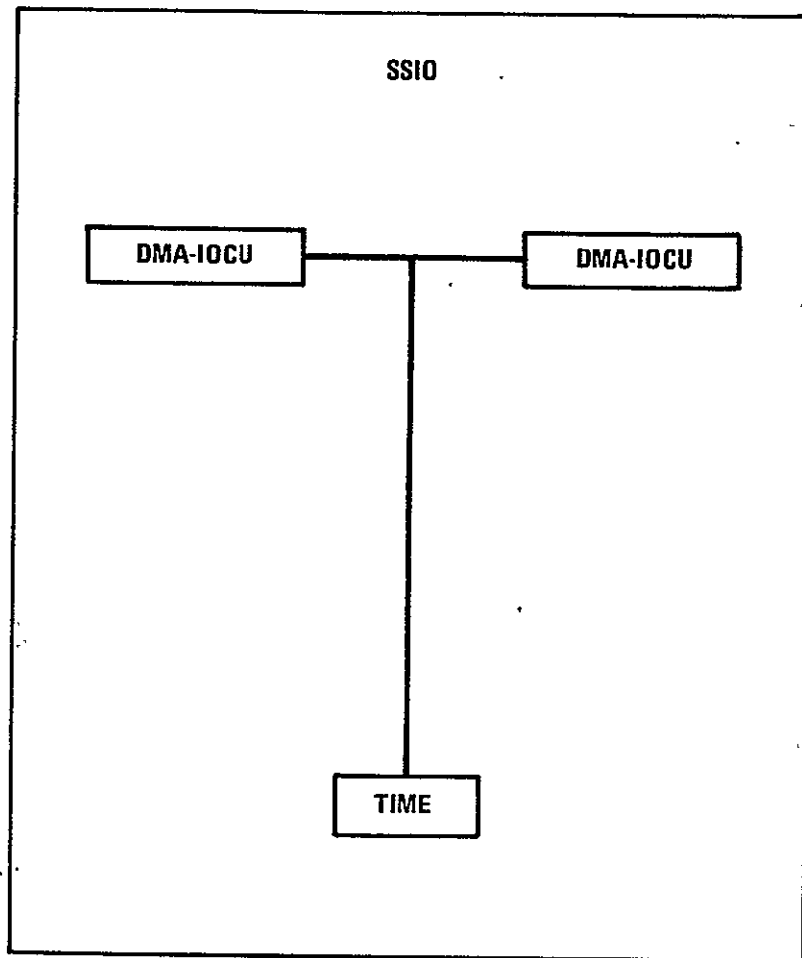

(i'') 29,30.

Figure 6.- Continued.

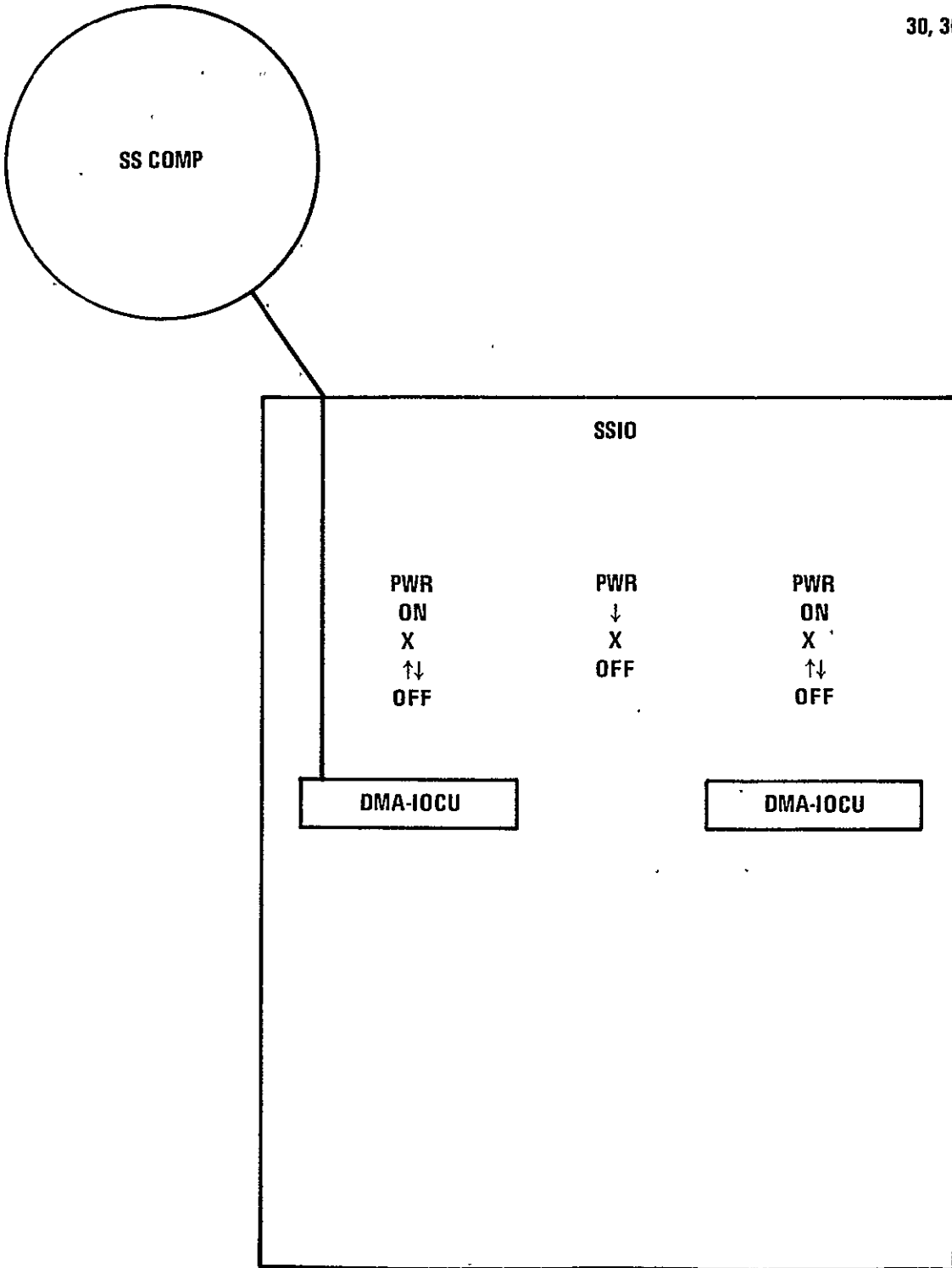

(j'!) 30,30.

Figure 6.- Continued.

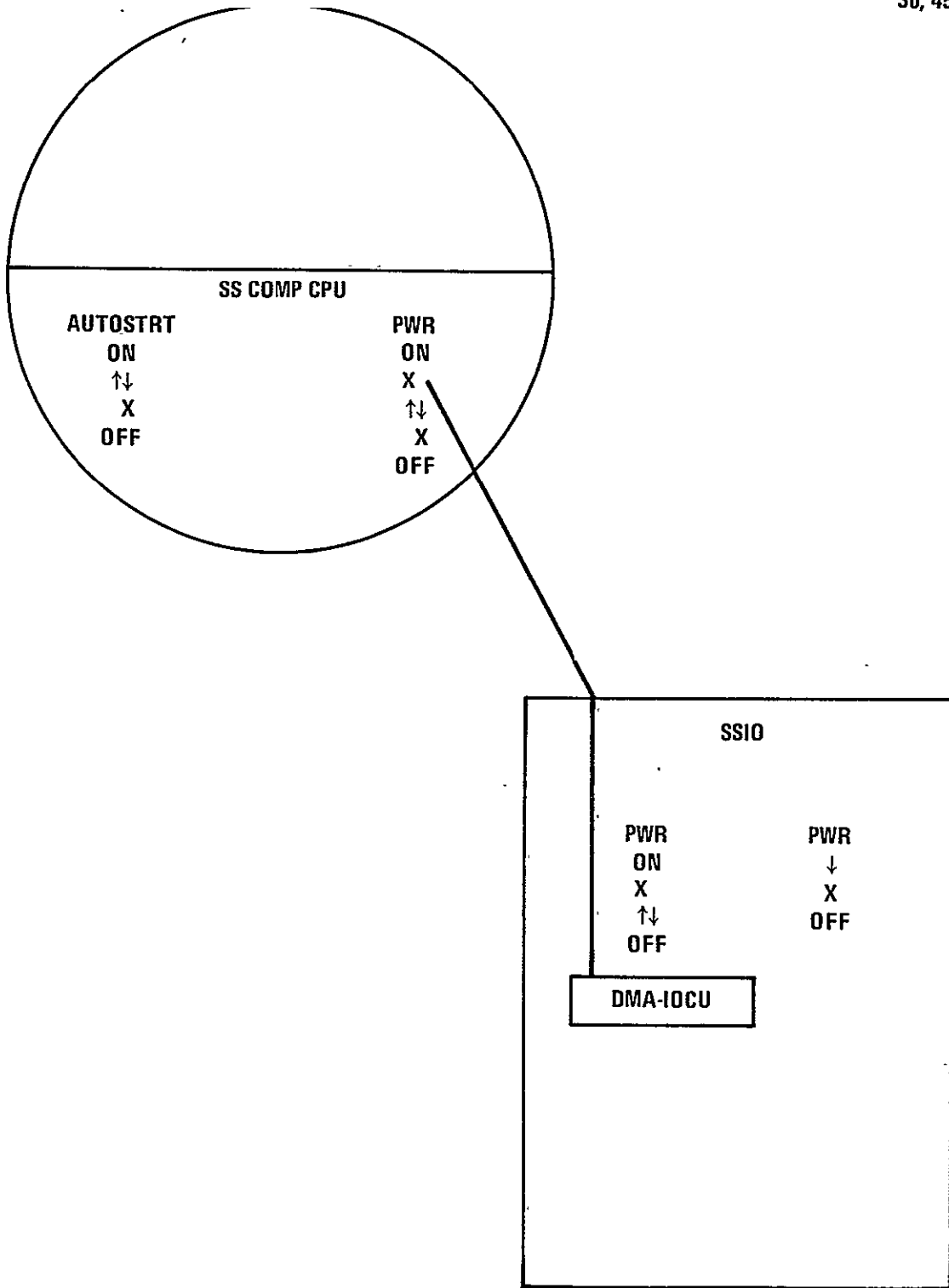

(k'') 30,45.

Figure 6.- Continued.

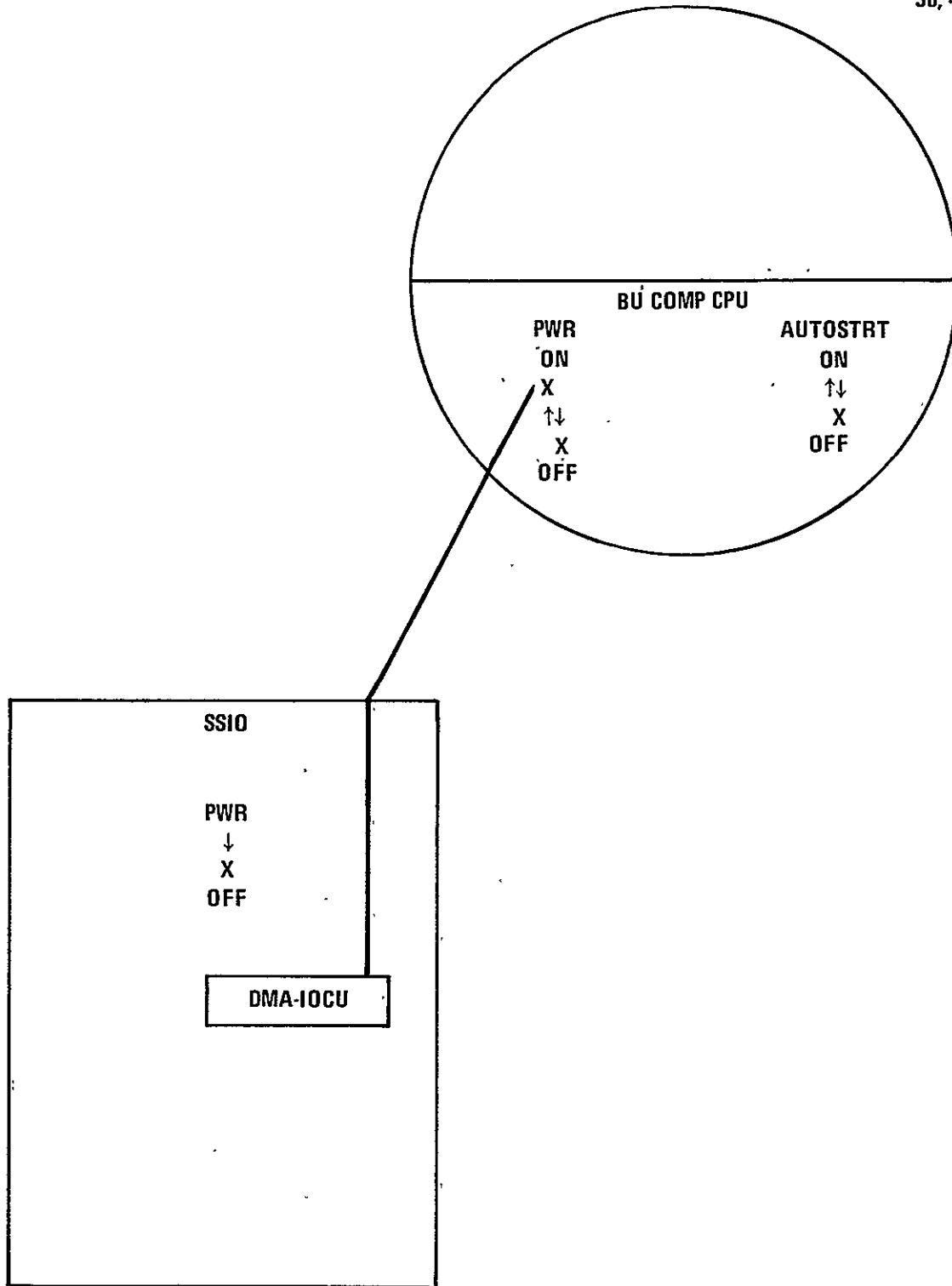

(1'') 30,47.

Figure 6.- Continued.

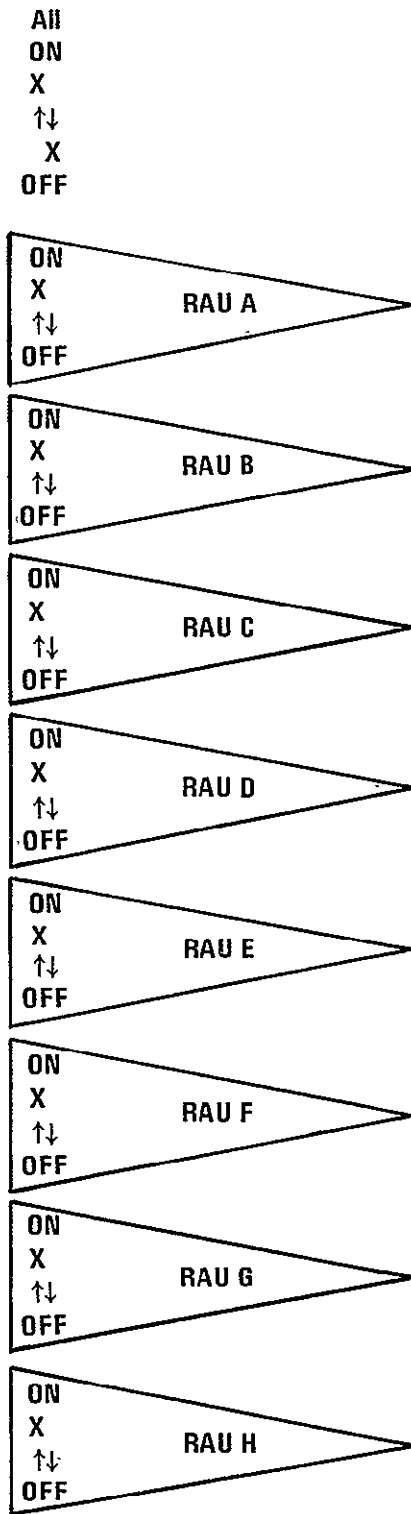

(m'') 32,32.

Figure 6.- Continued.

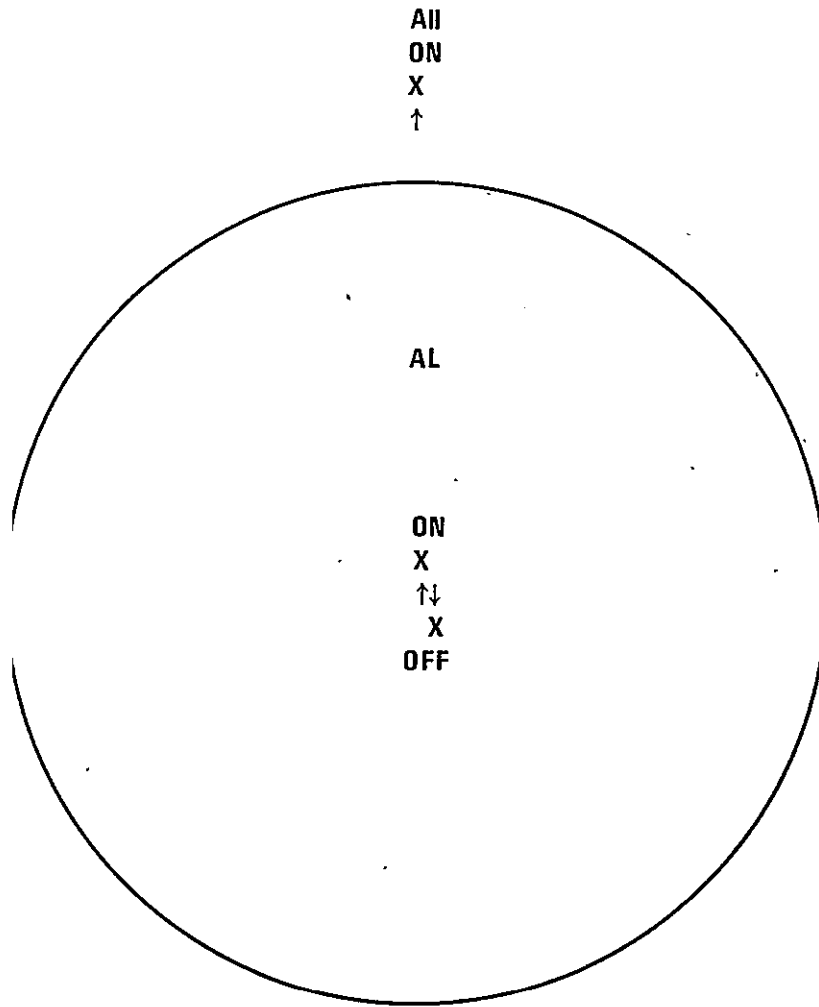

(n'') 33,33.

Figure 6.- Continued.

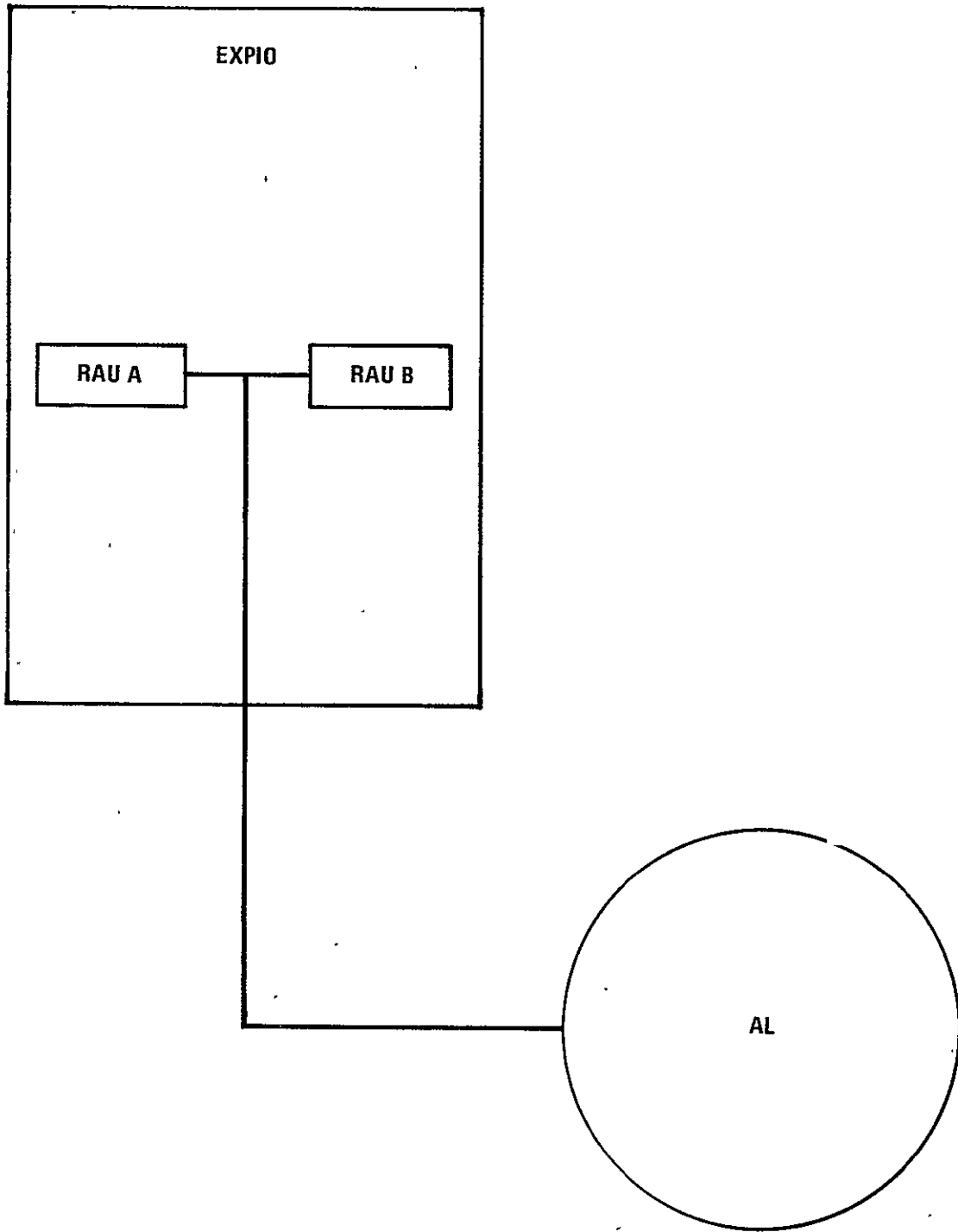

(o'') 33,37.

Figure 6.- Continued.

All
ON
X
↑

R2	R4	R6	R8	R10	R12
ON	ON	ON	ON	ON	ON
X	X	X	X	X	X
↑↓	↑↓	↑↓	↑↓	↑↓	↑↓
X	X	X	X	X	X
OFF	OFF	OFF	OFF	OFF	OFF
R1	R3	R5	R7	R9	R11
ON	ON	ON	ON	ON	ON
X	X	X	X	X	X
↑↓	↑↓	↑↓	↑↓	↑↓	↑↓
X	X	X	X	X	X
OFF	OFF	OFF	OFF	OFF	OFF

(p'') 34,34.

Figure 6.- Continued.

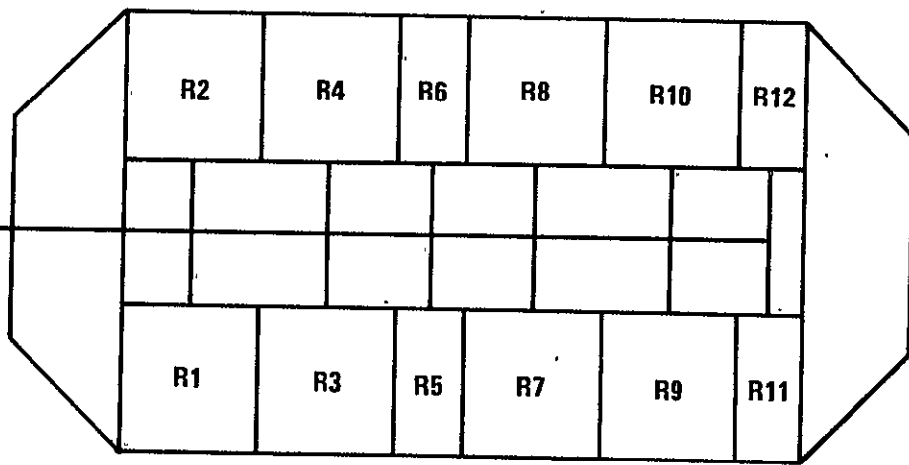
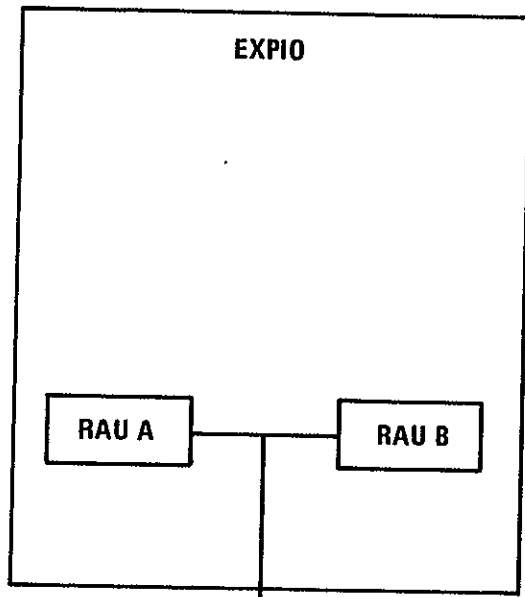

(q'') 34,37.

Figure 6.- Continued.

All
ON
X
↑

P1				P2				P3				P4				P5			
R1	R2	R3	R4	R1	R2	R3	R4	R1	R2	R3	R4	R1	R2	R3	R4	R1	R2	R3	R4
ON	ON	ON	ON	ON	ON	ON	ON	ON	ON	ON	ON	ON	ON	ON	ON	ON	ON	ON	ON
X	X	X	X	X	X	X	X	X	X	X	X	X	X	X	X	X	X	X	X
↑↓	↑↓	↑↓	↑↓	↑↓	↑↓	↑↓	↑↓	↑↓	↑↓	↑↓	↑↓	↑↓	↑↓	↑↓	↑↓	↑↓	↑↓	↑↓	↑↓
X	X	X	X	X	X	X	X	X	X	X	X	X	X	X	X	X	X	X	X
OFF	OFF	OFF	OFF	OFF	OFF	OFF	OFF	OFF	OFF	OFF	OFF	OFF	OFF	OFF	OFF	OFF	OFF	OFF	OFF

172

(r'') 35,35.

Figure 6.- Continued.

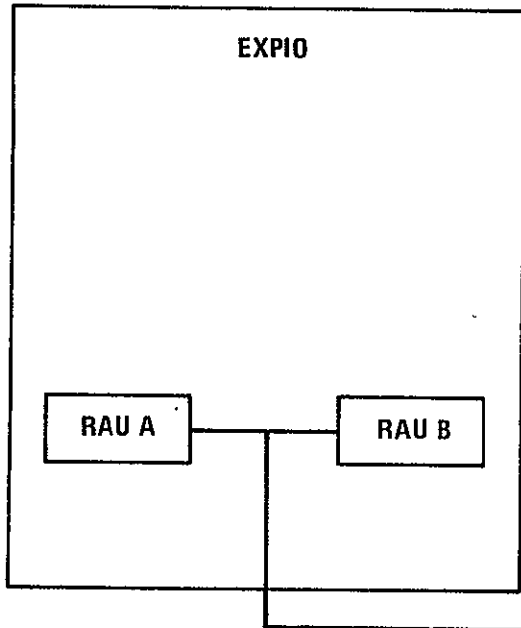

35, 37

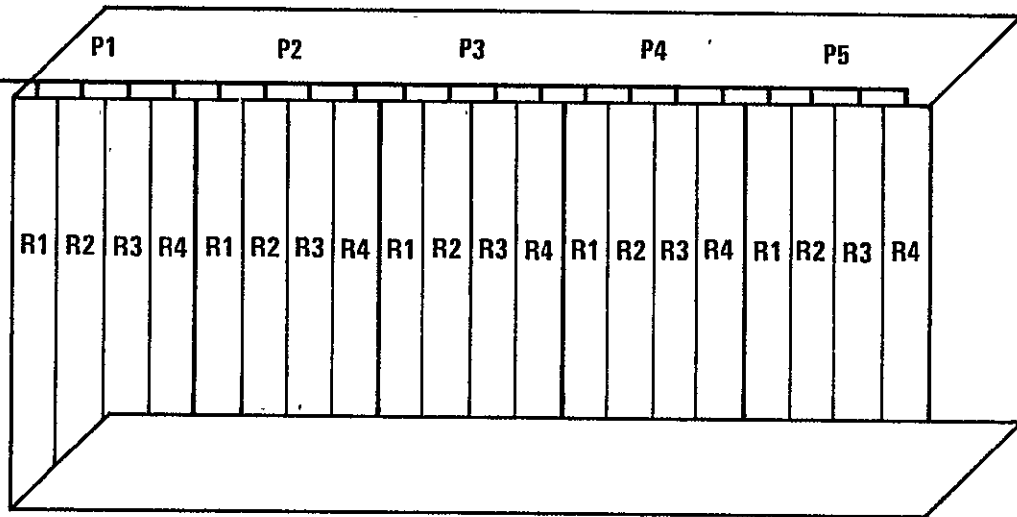

(s'') 35,37.

Figure 6.- Continued.

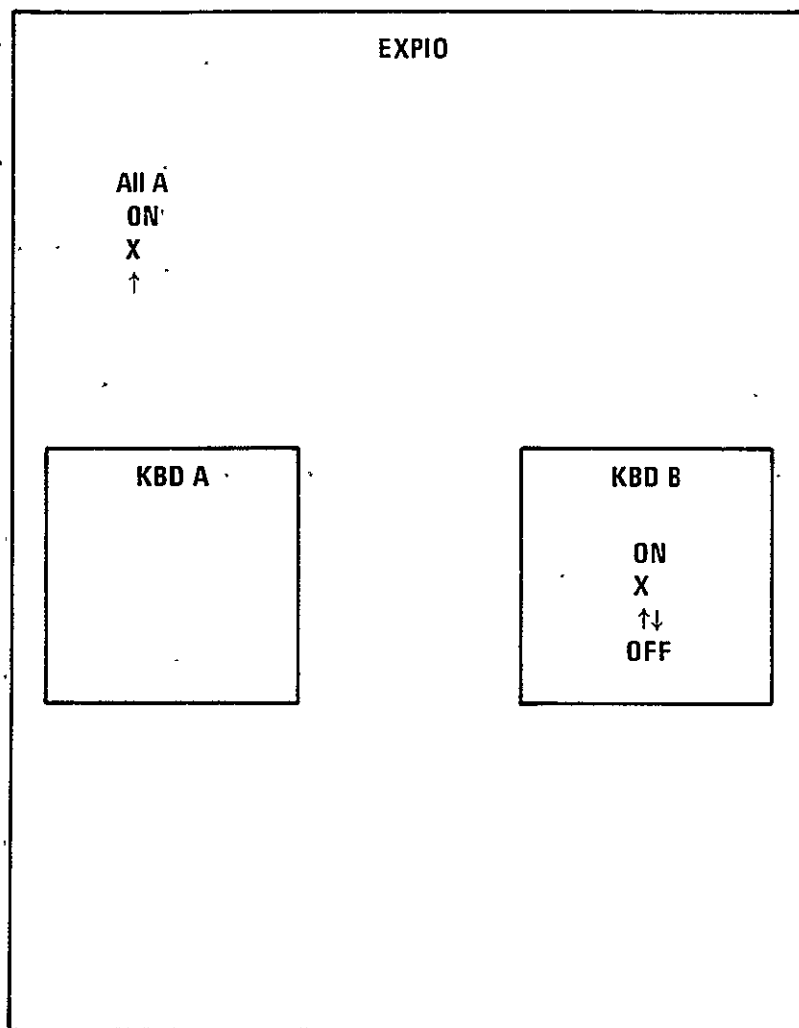

(t'') 36,36.

Figure 6.- Continued.

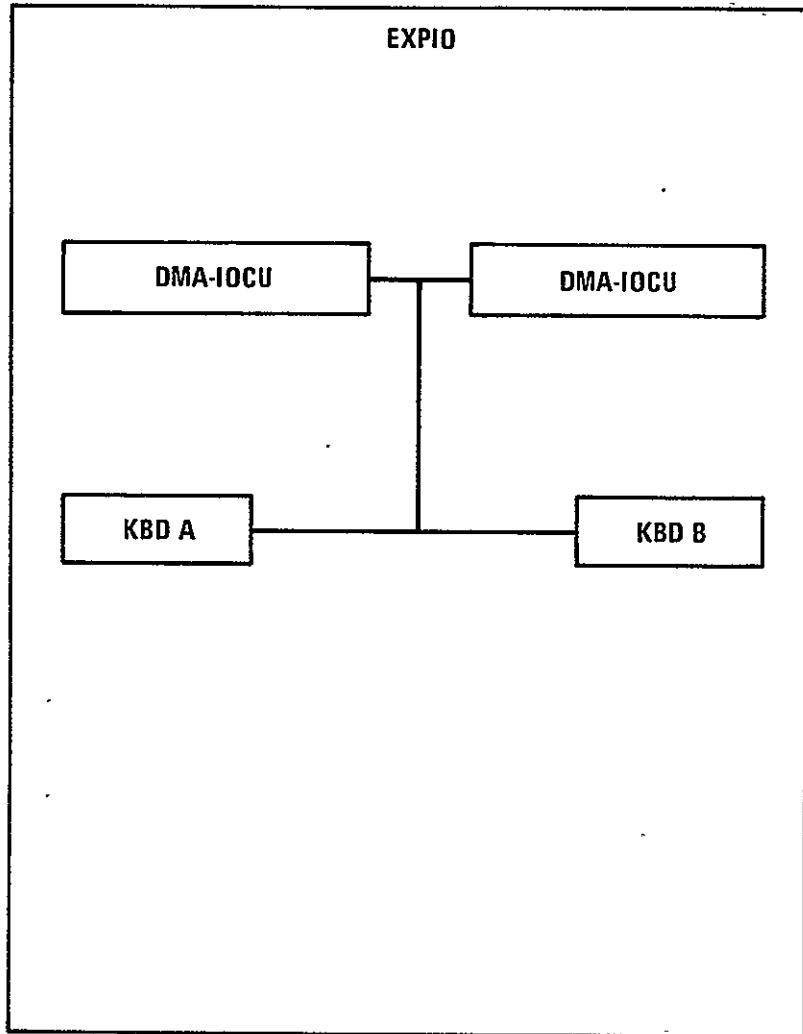

(u'') 36,43.

Figure 6.- Continued.

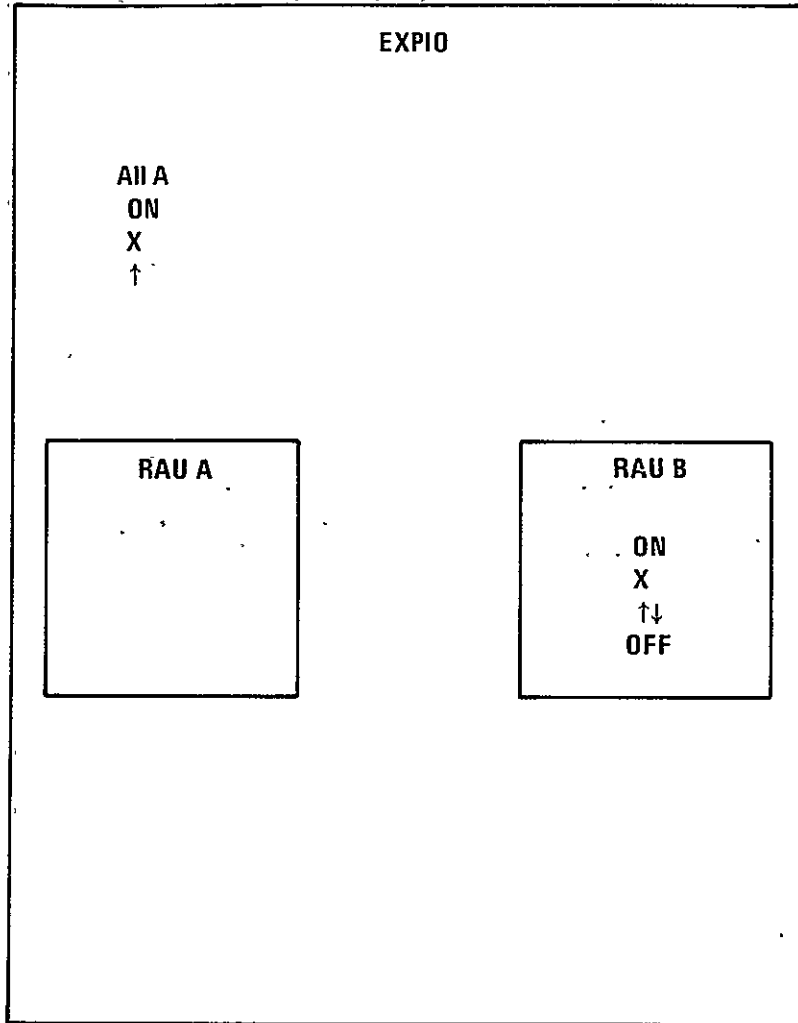

(v'') 37,37.

Figure 6.- Continued.

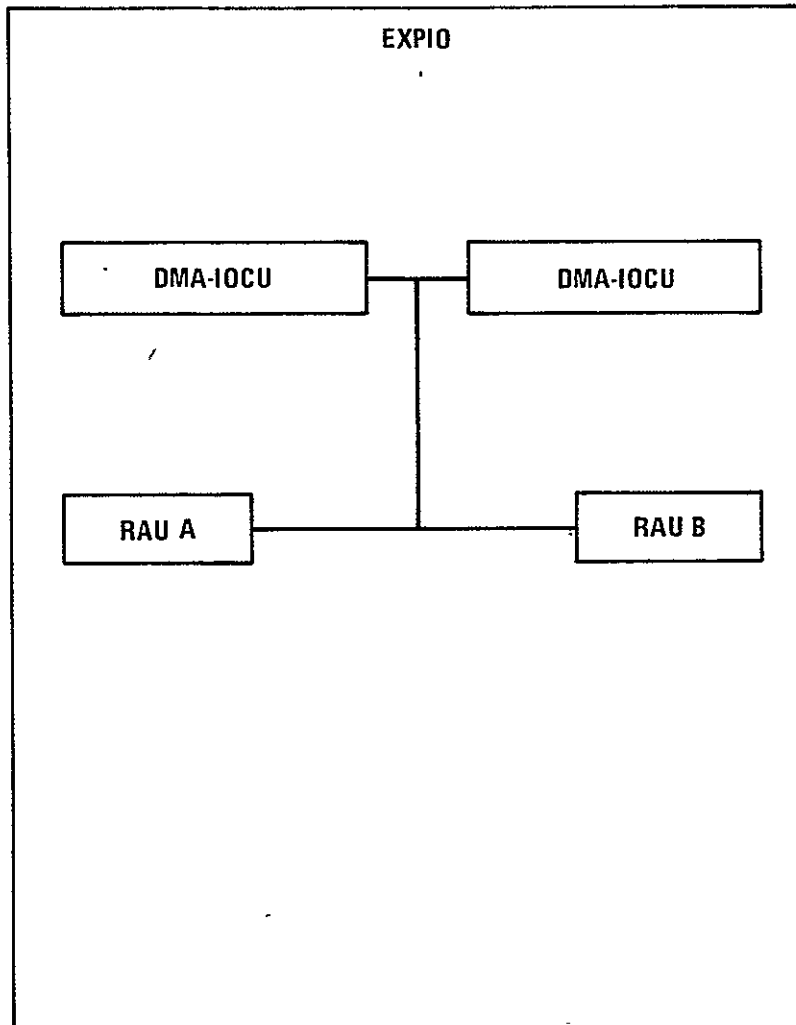

(w'') 37,43.

Figure 6.- Continued.

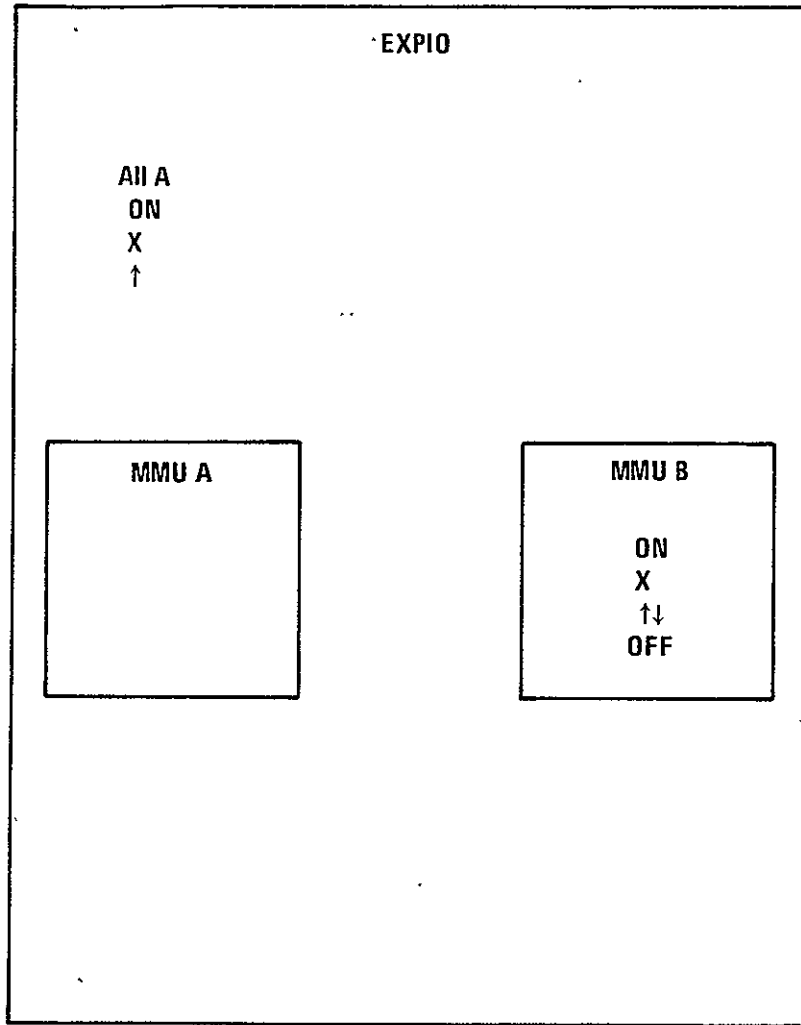

(x'') 38,38.

Figure 6.- Continued.

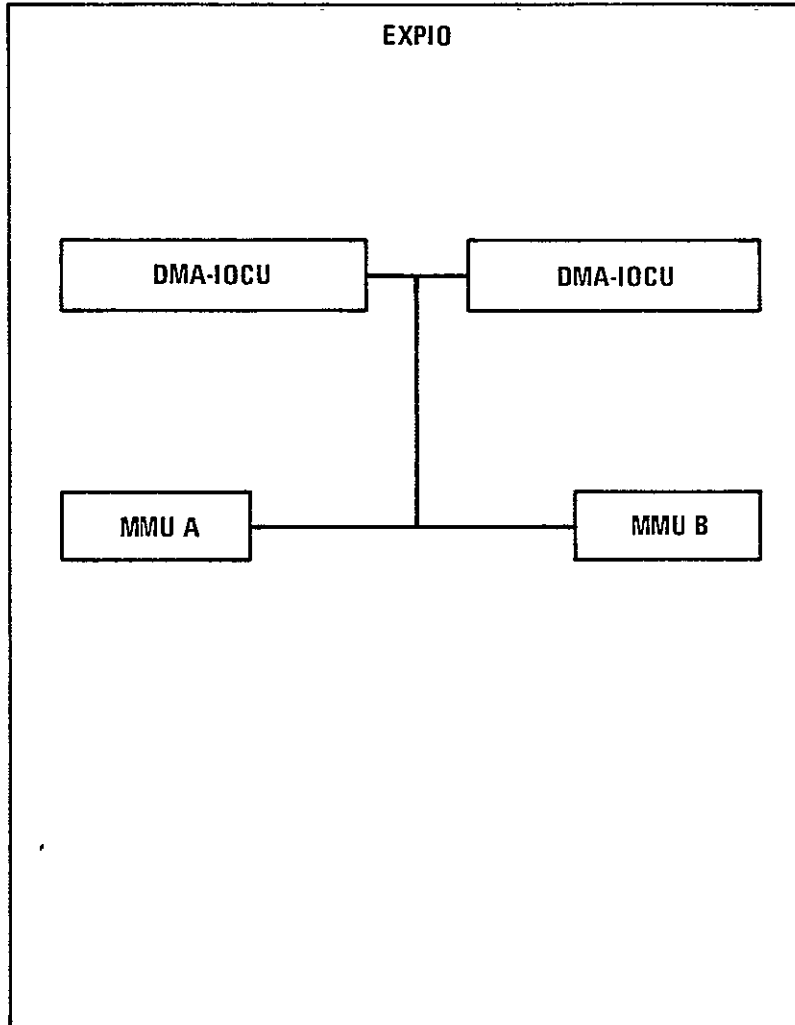

(y'') 38,43.

Figure 6.- Continued.

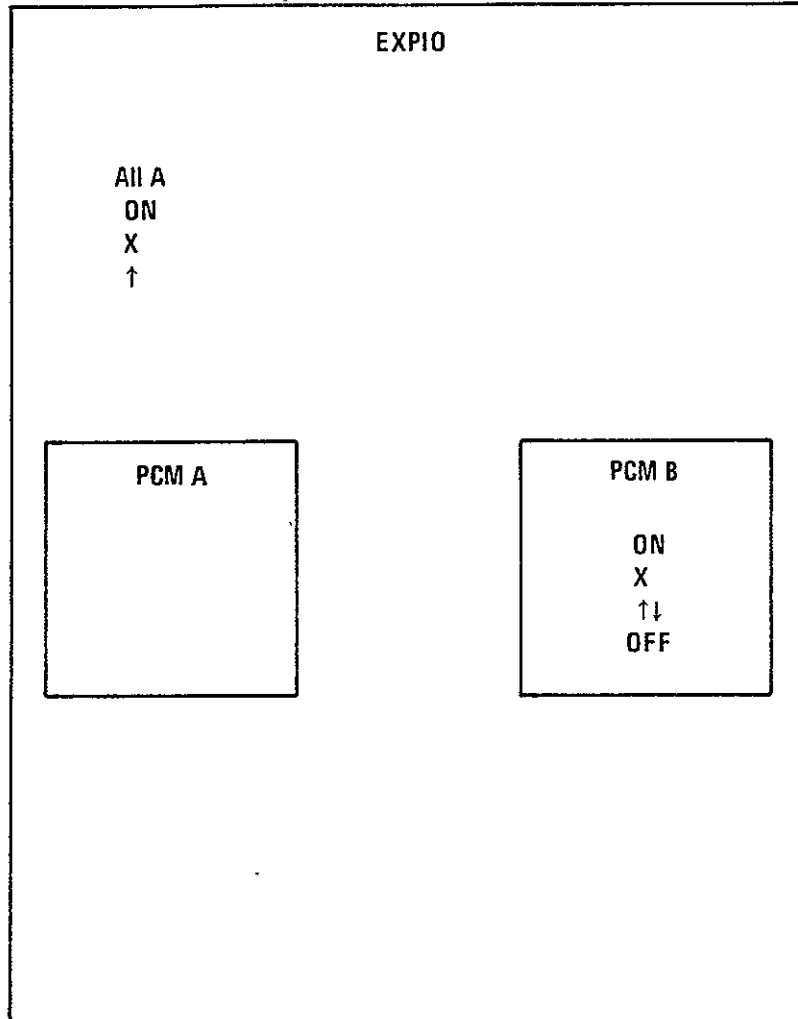

(z'') 39,39.

Figure 6.- Continued.

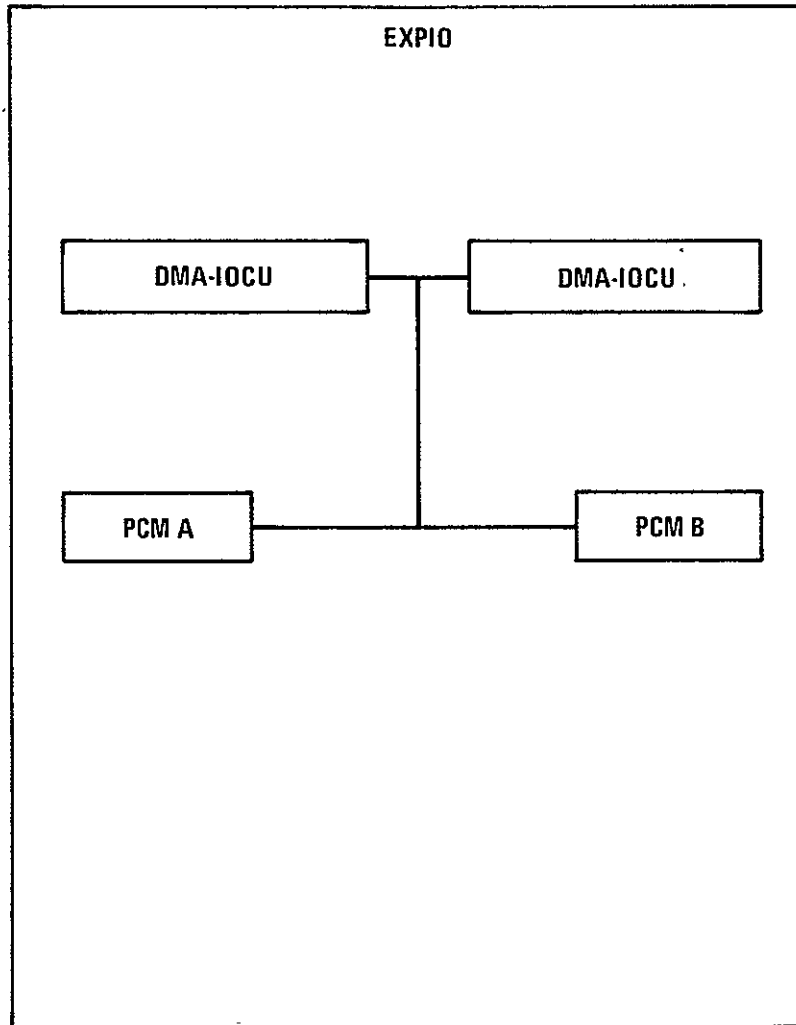

(a''') 39,43.

Figure 6.- Continued.

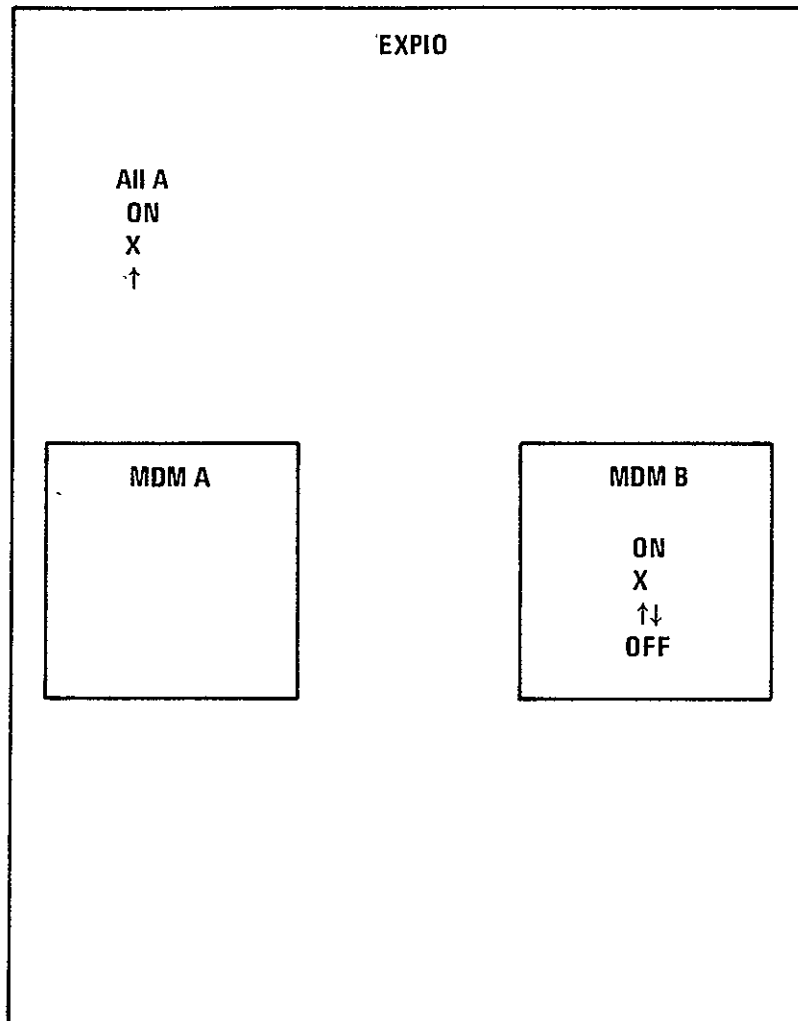

(b'') 40,40.

Figure 6.- Continued.

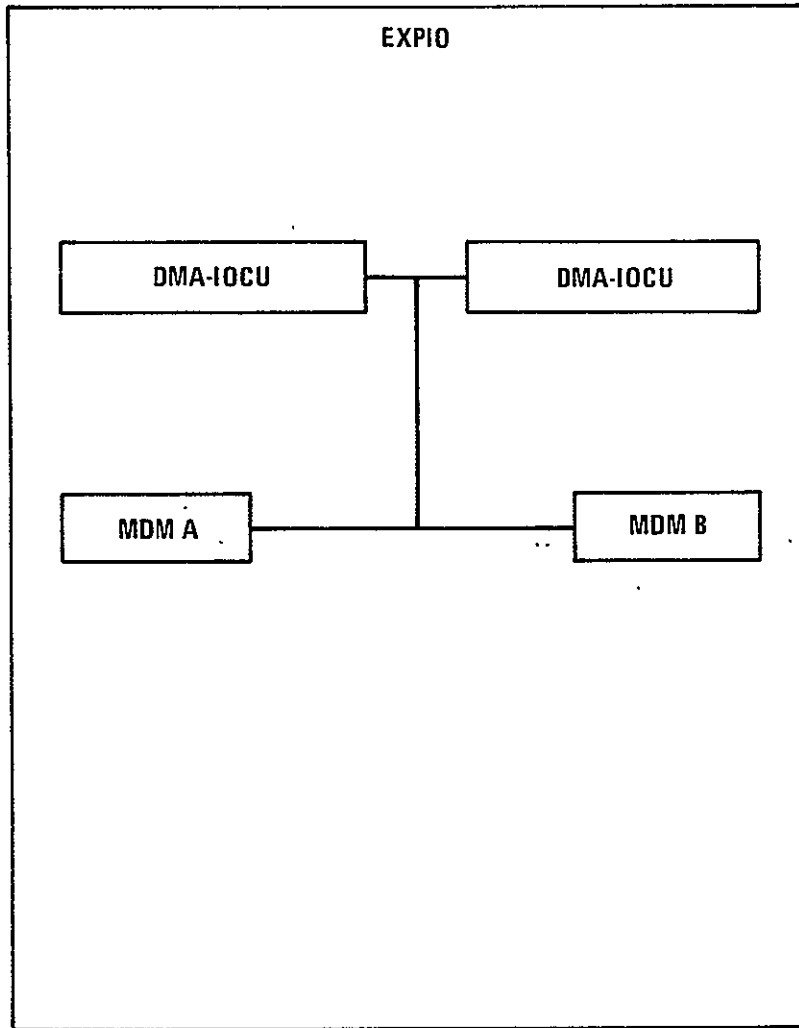

(c'') 40,43.

Figure 6.- Continued.

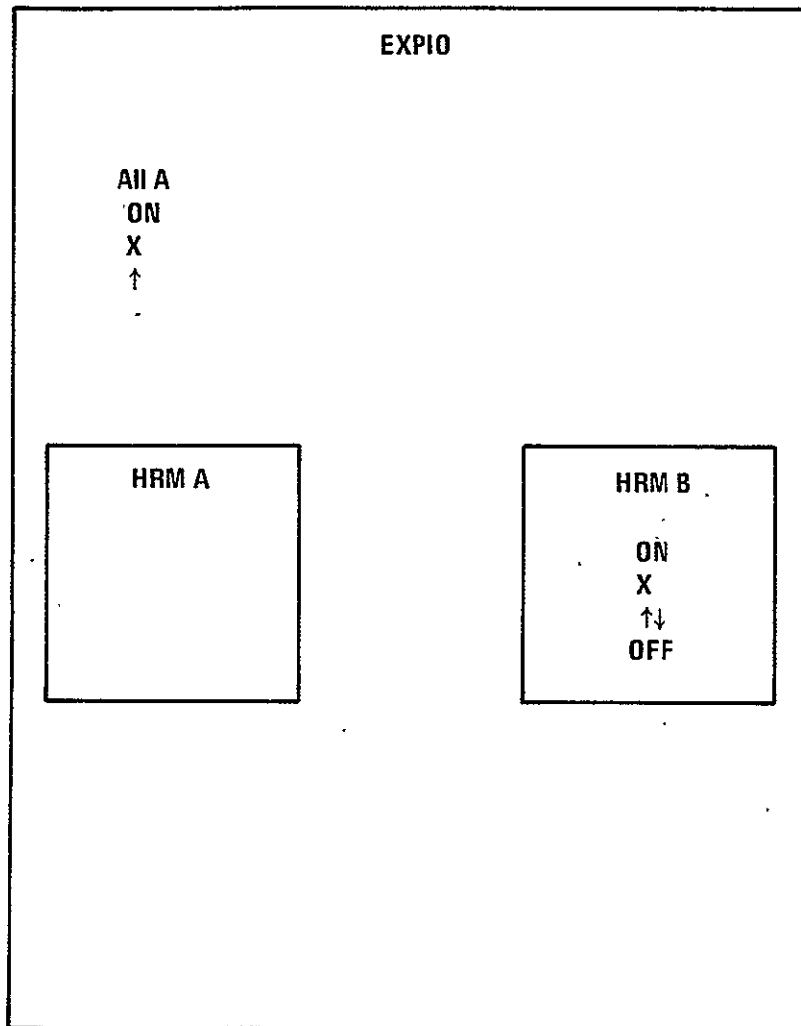

(d''') 41,41.

Figure 6.- Continued.

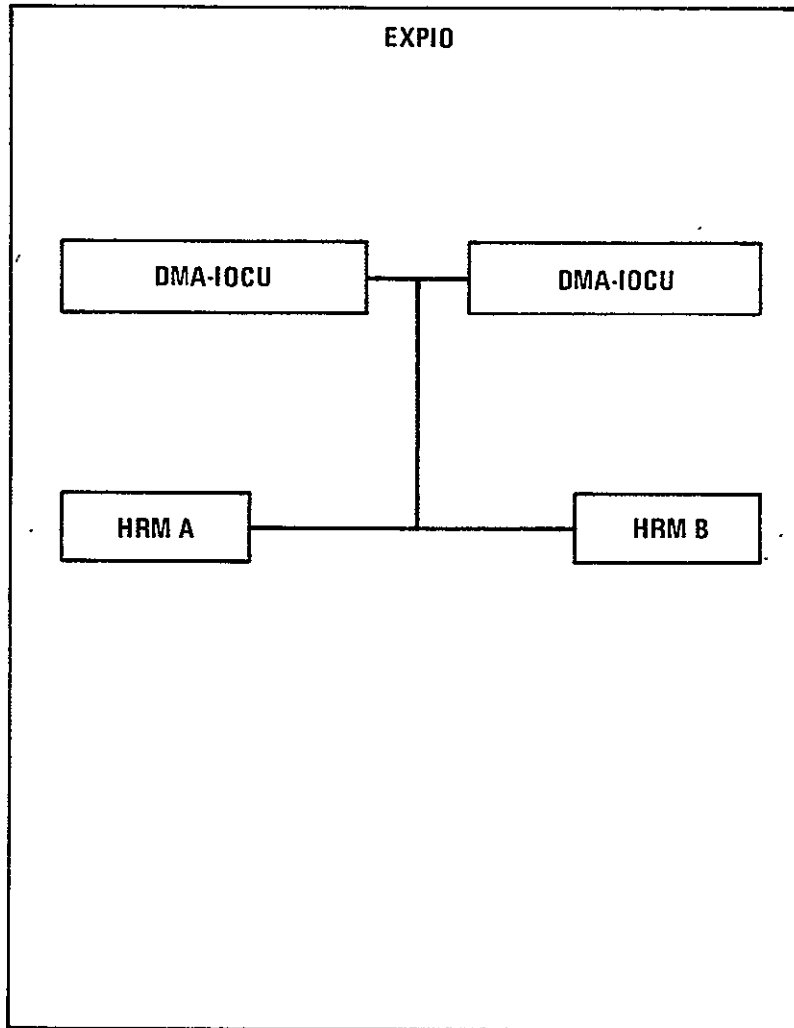

(e''') 41,43.

Figure 6.- Continued.

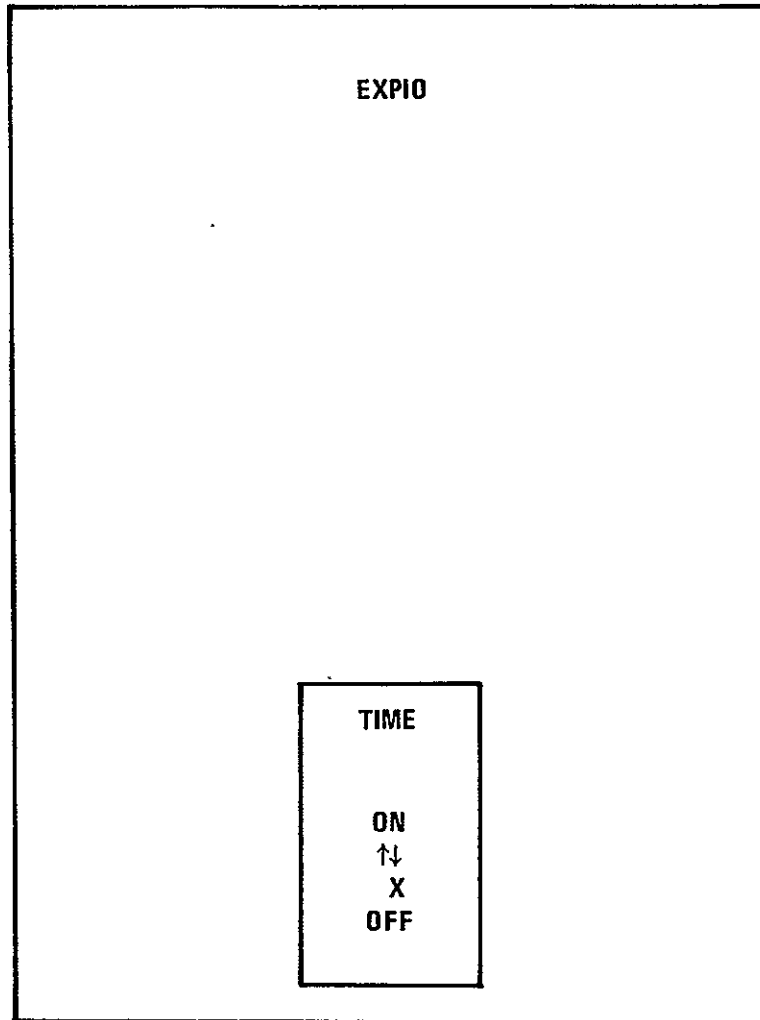

(f''') 42,42.

Figure 6.- Continued.

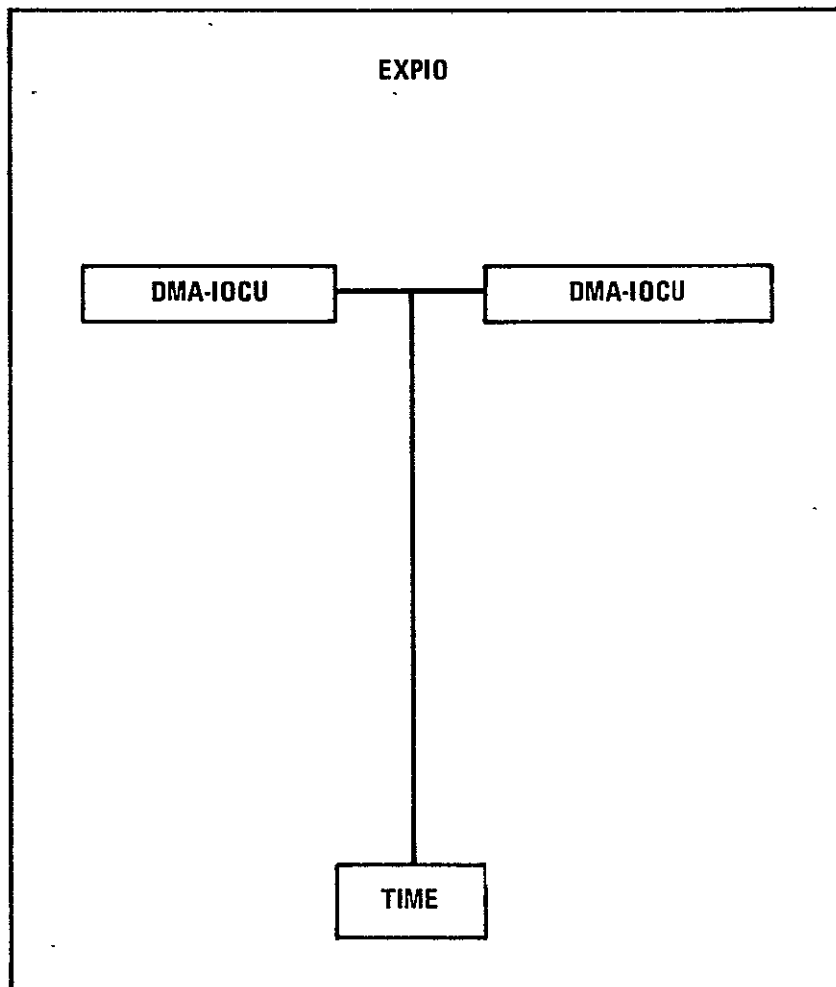

(g''') 42,43. .

Figure 6.- Continued.

43, 43

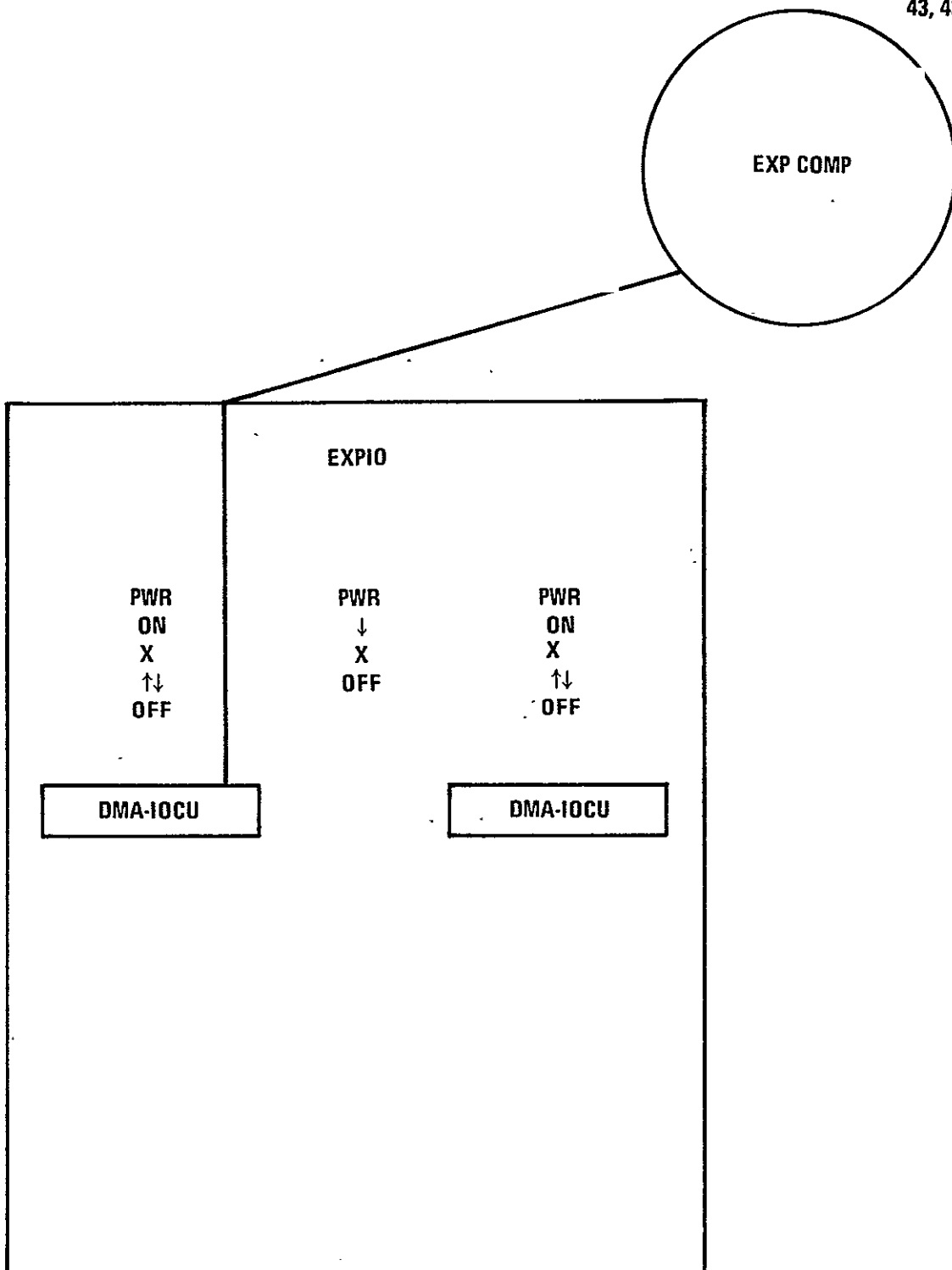

(h'') 43,43.

Figure 6.- Continued.

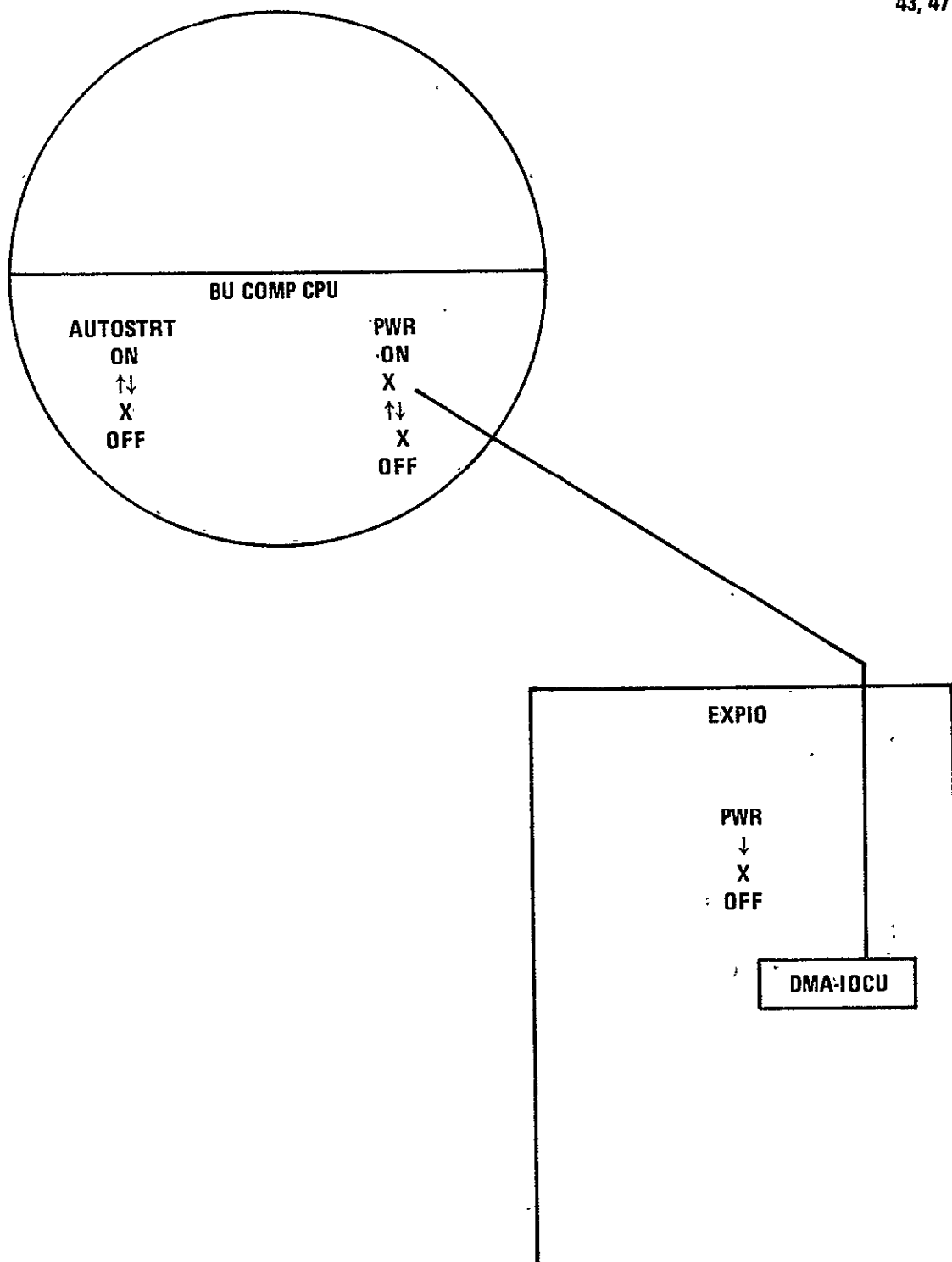

(i'') 43,47.

Figure 6.- Continued.

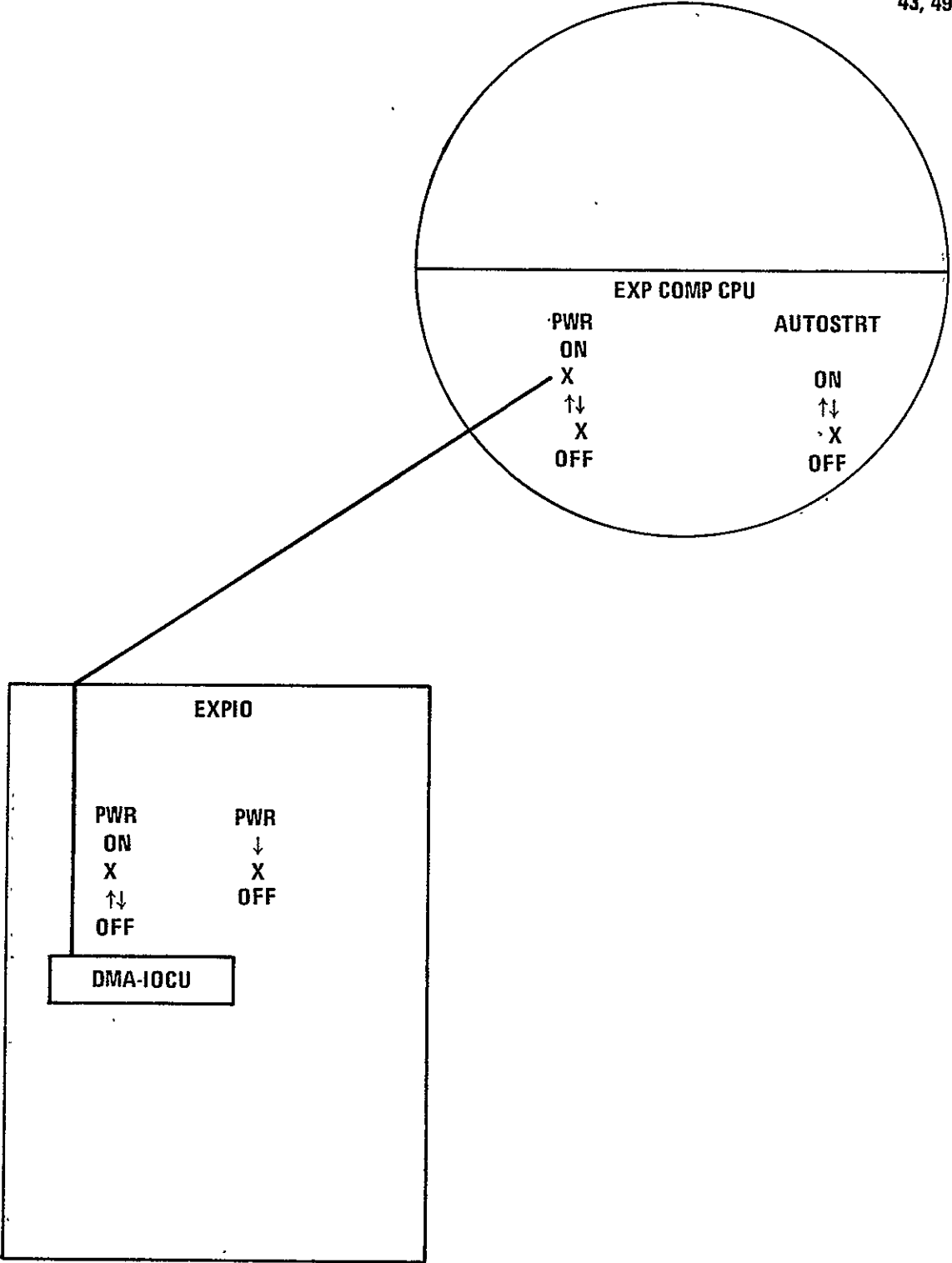

(j''') 43,49.

Figure 6.- Continued.

45,45

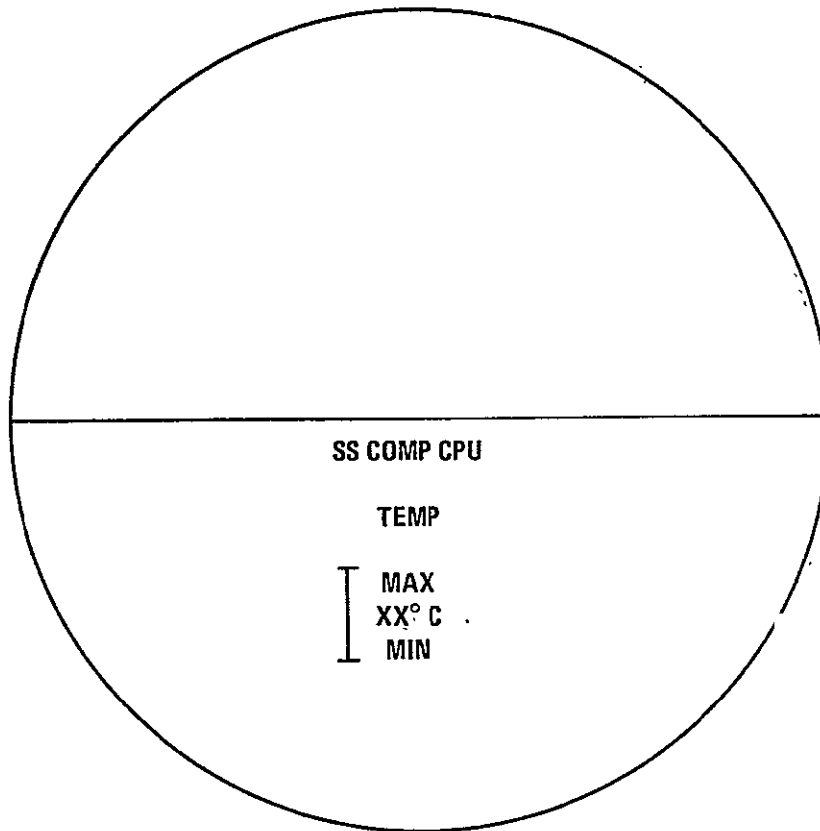

(k''') 45,45.

Figure 6.- Continued.

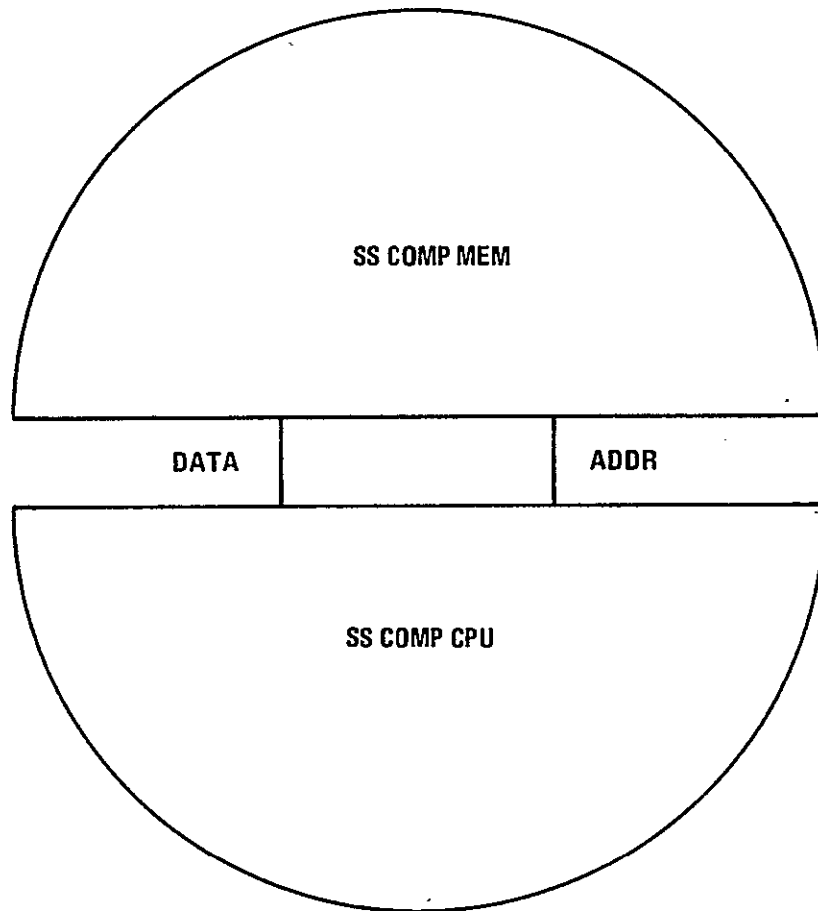

(1''') 45,46.

Figure 6.- Continued.

46,46

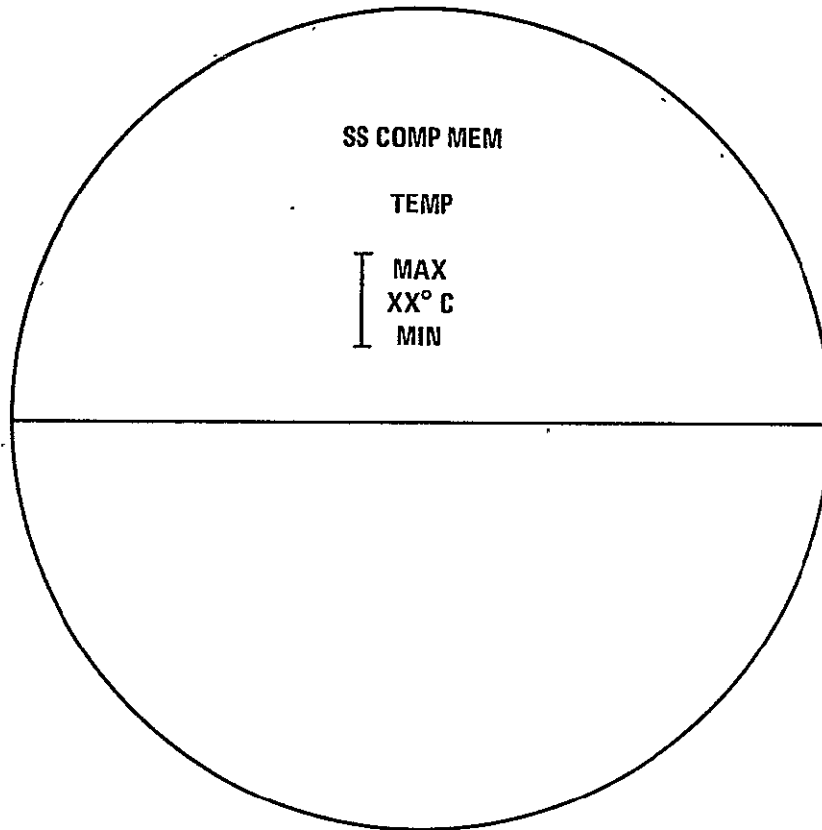

(m''') 46,46.

Figure 6.- Continued.

47,47

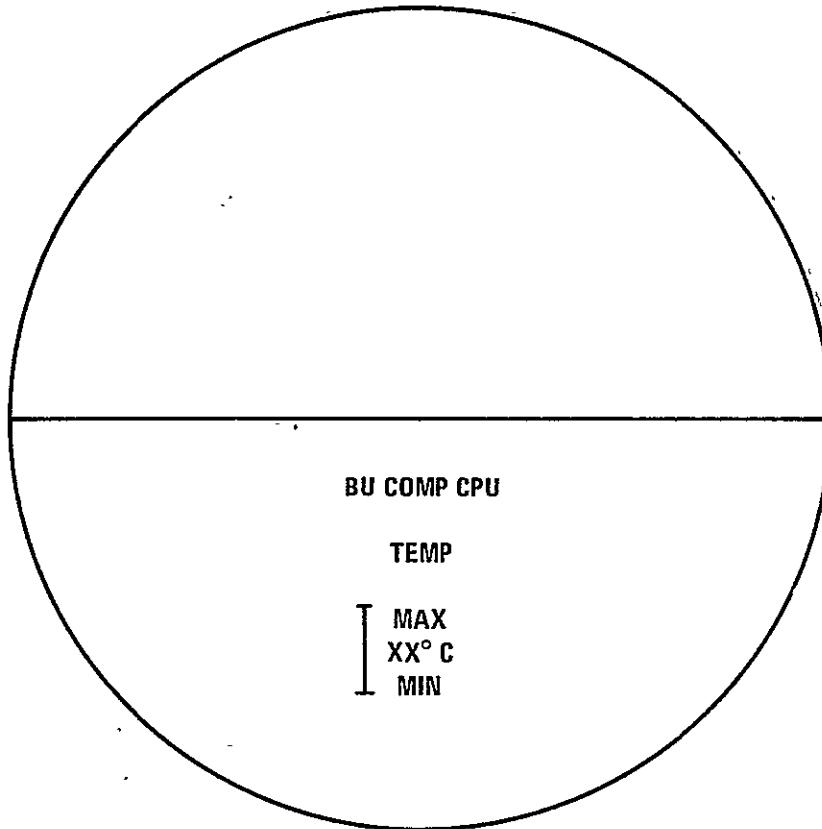

(n''') 47,47.

Figure 6.- Continued.

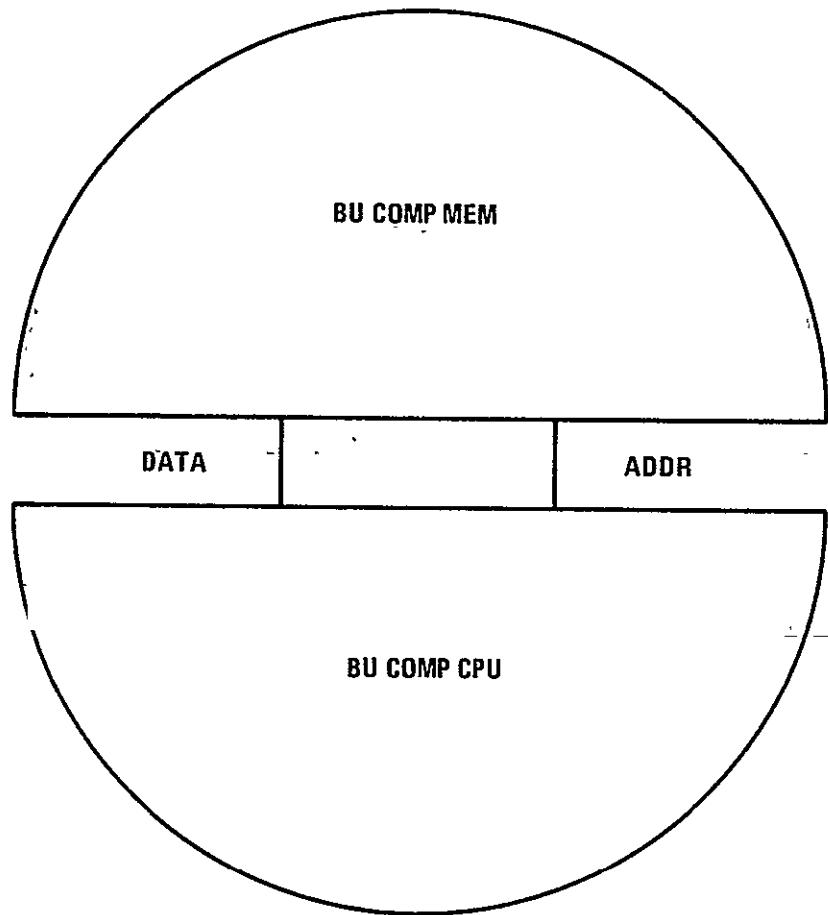

(o'') 47,48.

Figure 6.- Continued.

48,48

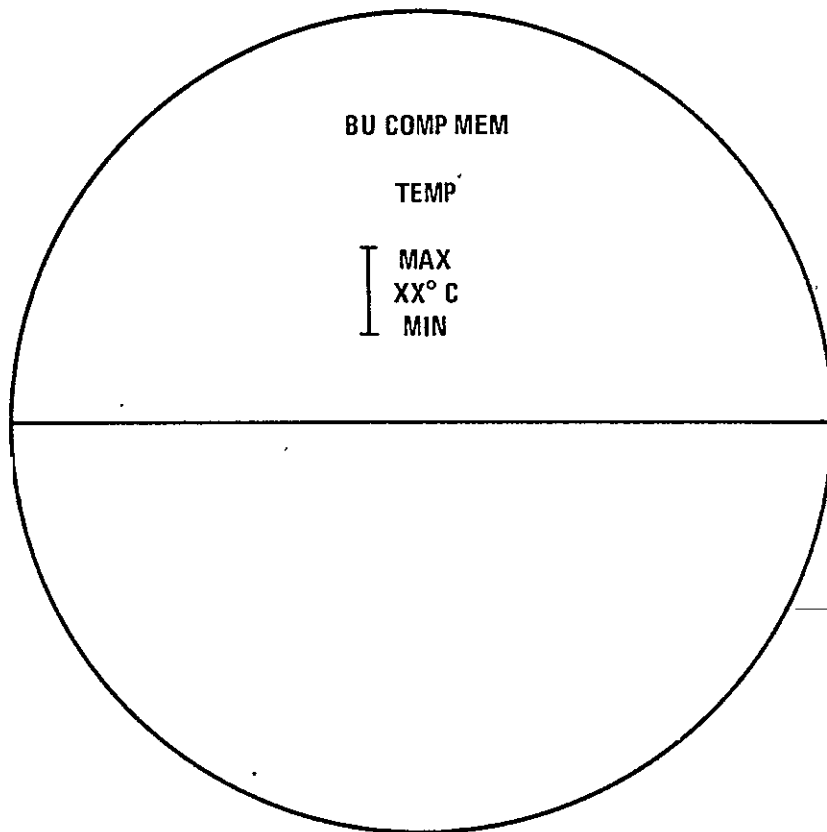

(p 111) 48,48.

Figure 6.- Continued.

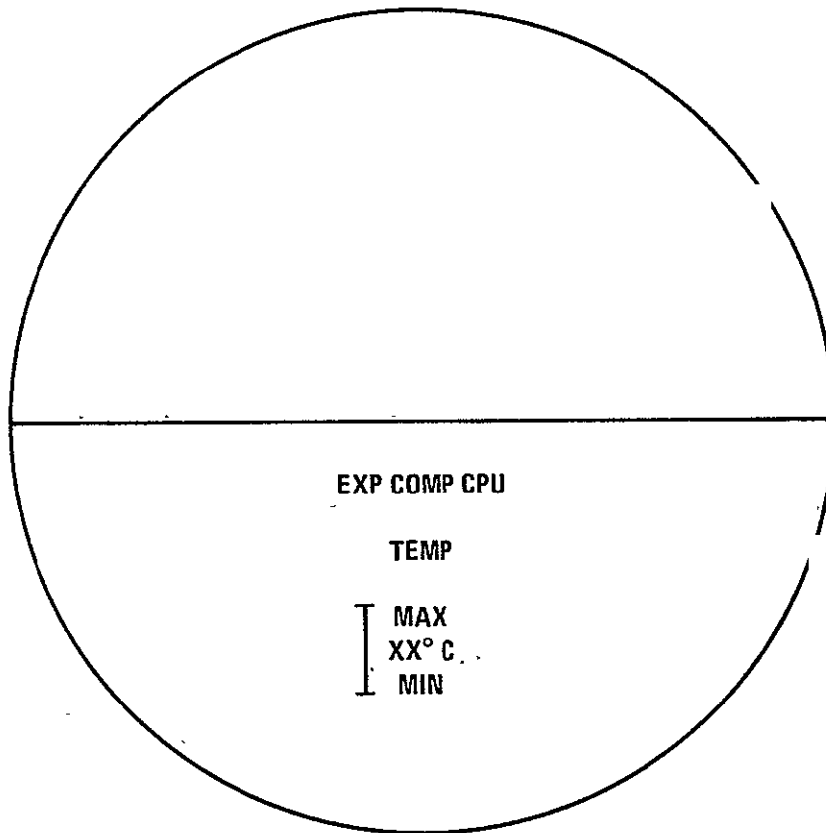

(q''') 49,49.

Figure 6.- Continued.

49,50

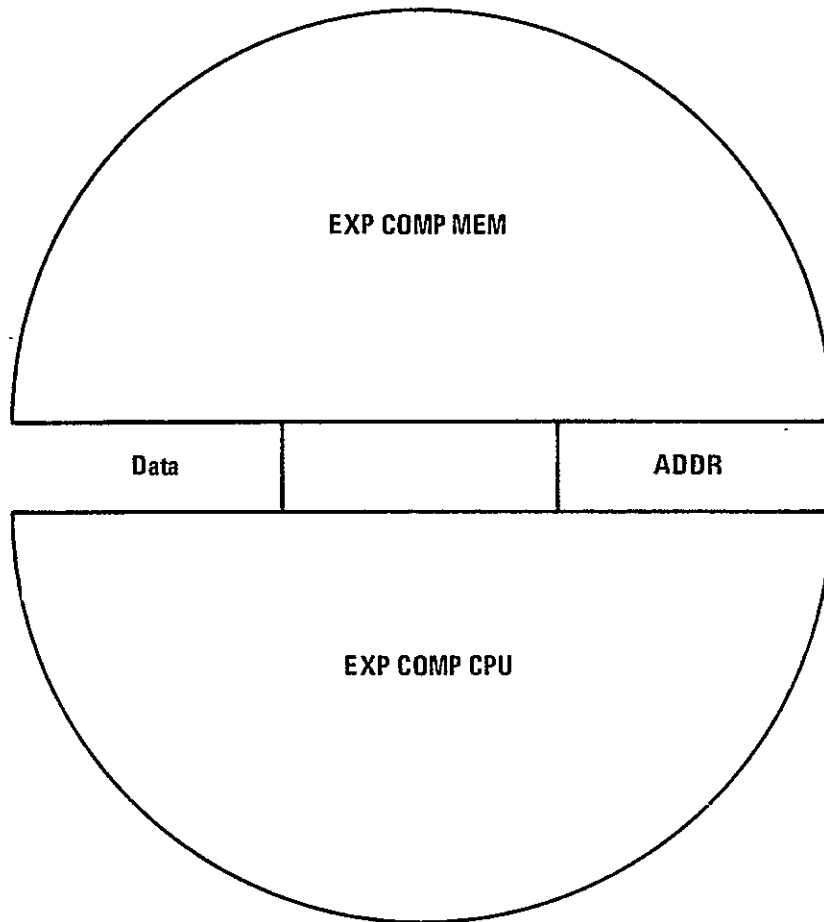

(r''') 49,50.

Figure 6.- Continued.

50,50

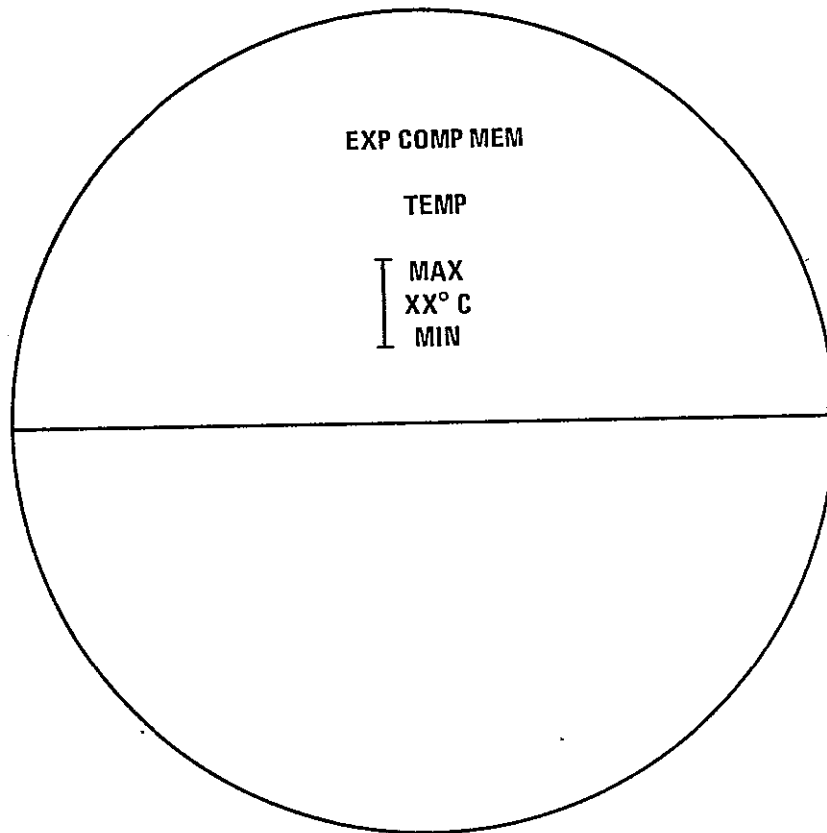

(s'') 50,50.

Figure 6.- Concluded.

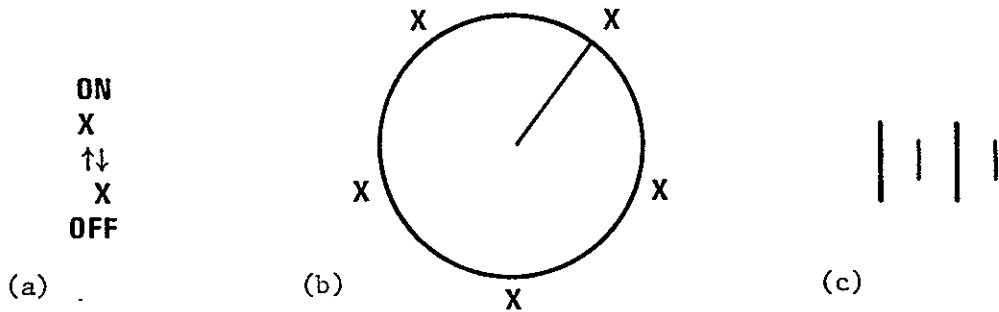

- (a) Toggle switch. The software equivalent of a toggle switch is meant to simulate the appearance of an equivalent hardware switch. The two X's, one above the up arrow and one below the down arrow, represent item numbers, the execution of which would be equivalent to the corresponding movement of a hardware switch. The arrows would nominally be displayed dashed. Execution of an item number would result in the appropriate arrow being displayed solid. This is the general form of the software toggle switch. Variations can be used. For example, expanded-matrix page (25,25) indicates that there is a command to turn MMU coupler B ON and a measurement to determine whether MMU coupler B is ON or OFF. However, there is no command to explicitly turn MMU coupler B OFF. Therefore, theoretical display (25,25) contains a software toggle switch that has an item number to turn MMU coupler B ON, and two arrows to indicate whether MMU coupler B is ON or OFF, but no item number to turn MMU coupler B OFF.
- (b) Rotary switch. Rotary switches can also be simulated in displays. The item number around the circular symbol would be labeled, and execution of an item number would cause the radius to point to that item number, to indicate that the simulated rotary switch had been moved to that position.
- (c) Electrical. Parameters that provide information relating to some electrical aspect of the subsystem utilize this commonly recognized symbol for a battery. This symbol can be used in two different ways. The first use is as a (GO, NOGO) indicator. Consider the measurement on page (2,2) of the expanded matrix, "SS COMP Secondary PWR (NOGO, GO) (X, C, C, B, B)." In theoretical display (2,2) the electrical symbol labeled SPWR would be displayed solid for a GO condition and either overbright or flashing for a NOGO condition, although overbright might be a slightly better choice because it would not be as distracting as a flashing indicator and would still command attention very easily. The second use is as a visual cue for the location of the display of an electrical parameter. Consider the measurement on page (7,7) of the expanded matrix, "MMU Secondary Voltage (VDC, -, -) (C, B, B, B, B)." In theoretical display (7,7), the electrical symbol labeled SPWR provides a visual cue to the location of the display of the MMU's secondary voltage, "XXV." The X's represent the digits of the voltage indicator.

Figure 7.- Symbol definition for expanded-matrix parameters.

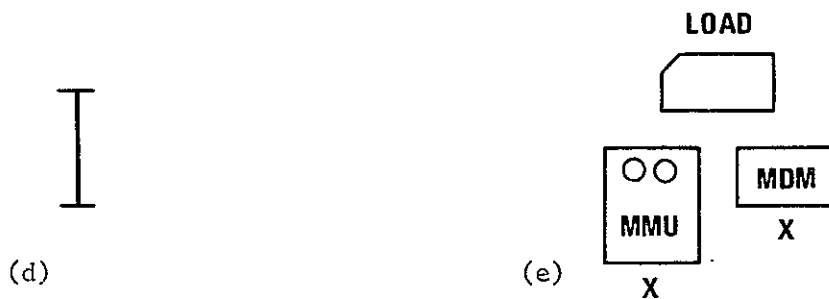

- (d) Temperature. Temperature parameters incorporate this symbol, which is supposed to be a temperature scale. The temperature symbol can be used in two different ways. The first use is as a (GO, NOGO) indicator. Consider the measurement on page (3,3) of the expanded matrix, "EXP COMP Internal TEMP (NOGO, GO) (X, D, D, C, C)." In theoretical display (3,3), the temperature symbol would be displayed solid for a GO condition and either overbright or flashing for a NOGO condition. The second use is as a visual cue for the location of the display of a temperature parameter. Consider the measurement on page (5,5) of the expanded matrix, "EXP I/O TEMP (deg C) (C, D, D, C, C,)." In theoretical display (5,5), the temperature symbol provides a visual cue to the location of the display of the EXPIO's temperature, "XX° C." "XX° C" would be the actual temperature of the EXPIO whereas "MAX" and "MIN" would be the maximum and minimum allowable temperatures, respectively. The display of "MAX" and "MIN" would greatly aid a crewmember in the determination of the temperature status of the EXPIO. An additional and very desirable feature would be the display of a moving bug on the temperature symbol, the bug reaching the top of the scale when "MAX" temperature is reached, and the bottom of the scale when "MIN" temperature is reached. However, the software cost of implementing a bug of this nature is so high that it would be impractical unless it was considered to be absolutely necessary.
- (e) Load. This group of symbols appears in theoretical displays (2,2), (3,3), and (6,6) for the purpose of loading the main memories of the SS COMP, EXP COMP, and BU COMP, respectively. As can be determined from the corresponding pages in the expanded matrix, there are two possible sources from which a computer can be loaded, the MMU and the MDM. Execution of the item number appearing under the standard MMU symbol would result in the loading of the appropriate computer from the MMU. Similarly, execution of the item number appearing under the standard MDM symbol would result in the loading of the appropriate computer from the MDM. The small punch card shaped symbol under Load is nominally displayed dashed. When a Load is attempted, and if it is GO, the symbol would be displayed solid. If the attempted Load is NOGO, the symbol would be displayed either overbright or flashing.

Figure 7.- Continued.

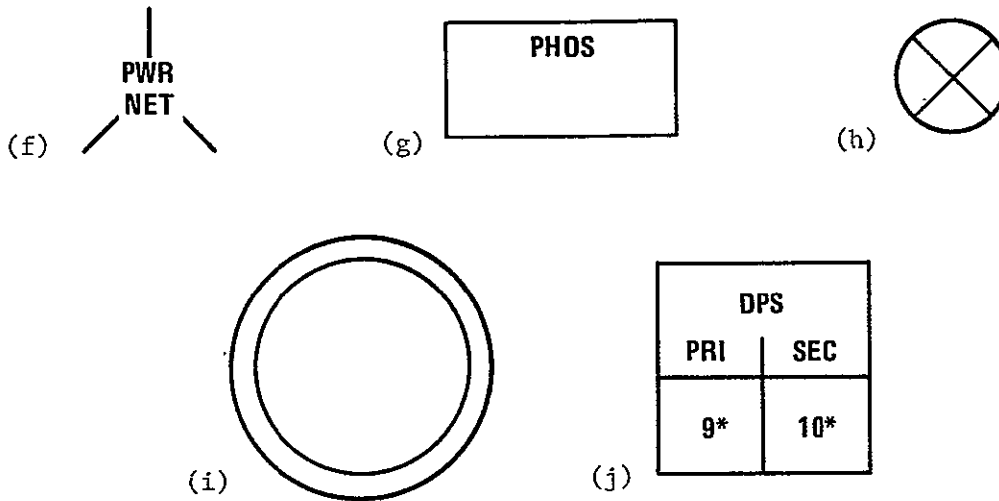

- (f) Power network. This symbol is meant to resemble a radiating network and is displayed either normal intensity solid or else overbright or flashing to indicate that a computer's power network is in a GO or NOGO condition, respectively.
- (g) Phosphor protection. Appearing only in display (12,12) is the phosphor protection symbol. It corresponds to the measurement "DDUi Phosphor Protection (NOGO, GO) (X, A, A, A, A), i = 1,2,3" and is a (GO, NOGO) indicator. Its rectangular shape is meant to represent a CRT screen.
- (h) Motor. Appearing only in theoretical display (16,16), this symbol provides a visual cue to the location of the display of the HRDR motor current. Its shape is meant to vaguely resemble the spinning brushes in an electric motor.
- (i) HRDR tape. Appearing only in theoretical display (16,16), these symbols indicate whether the beginning or end of the HRDR tape has been reached. The outer circle is always displayed solid, and the inner circle is nominally displayed dashed. When one end of the tape has been reached, the inner circle of the appropriate symbol is displayed solid.
- (j) Data processing subsystem (DPS) control. Appearing only in theoretical displays (8,9) and (8,10), this symbol corresponds to the only DPS entries, "dcov DPS," in the matrix. It represents a small section of the DPS display that is used to mode the payload (PL) buses. Execution of item number 9 of the DPS display causes the primary ports of the PL MDM's to be used and the asterisk associated with 9 to be displayed. Execution of item number 10 of the DPS display causes the PL MDM's secondary ports to be used and the asterisk associated with 10 to be displayed.

Figure 7.- Concluded.

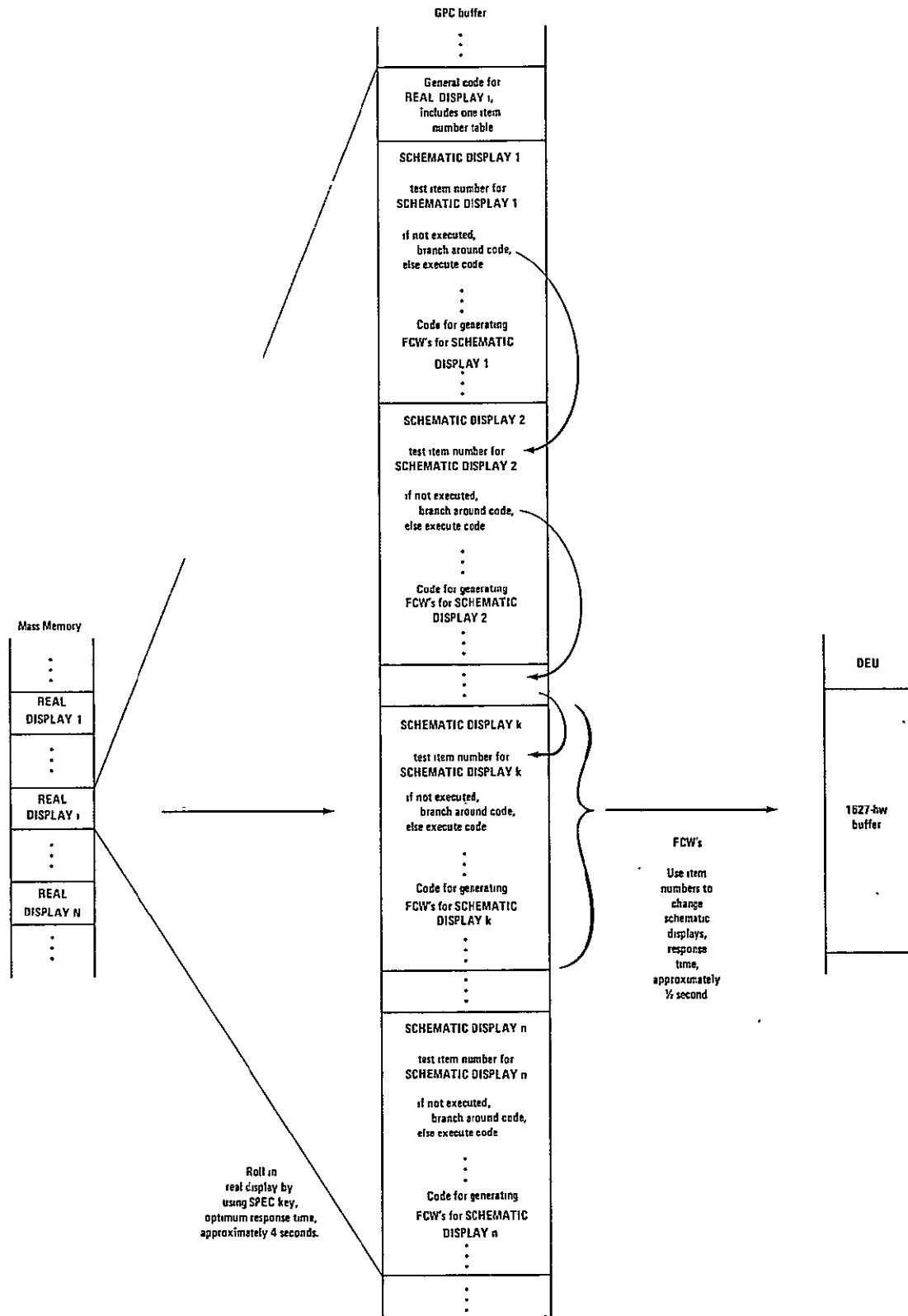

Figure 8.- Roll-in technique.

ORIGINAL PAGE IS
OF POOR QUALITY

ORIGINAL QUALITY OF POOR

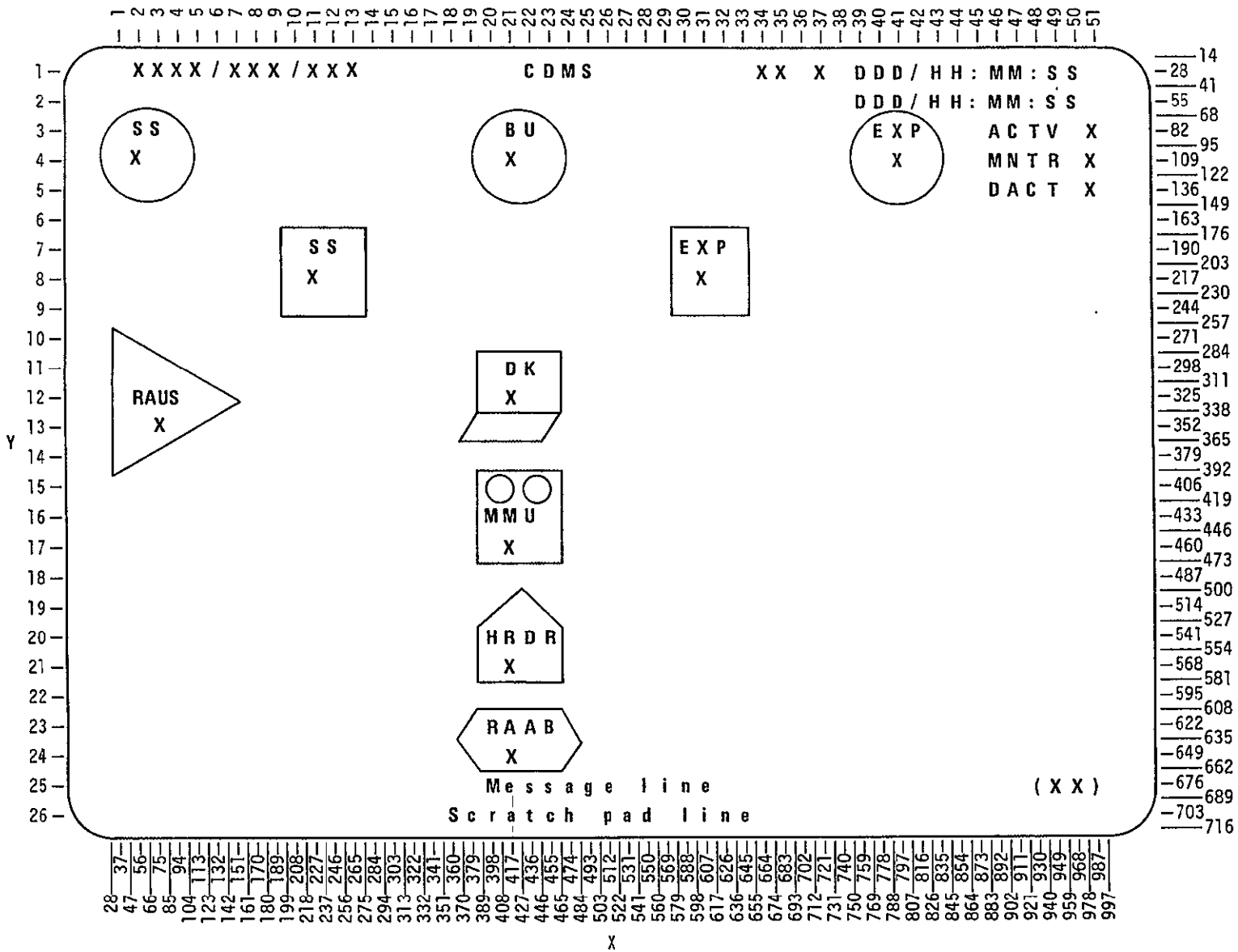

Figure 9.- Index display.

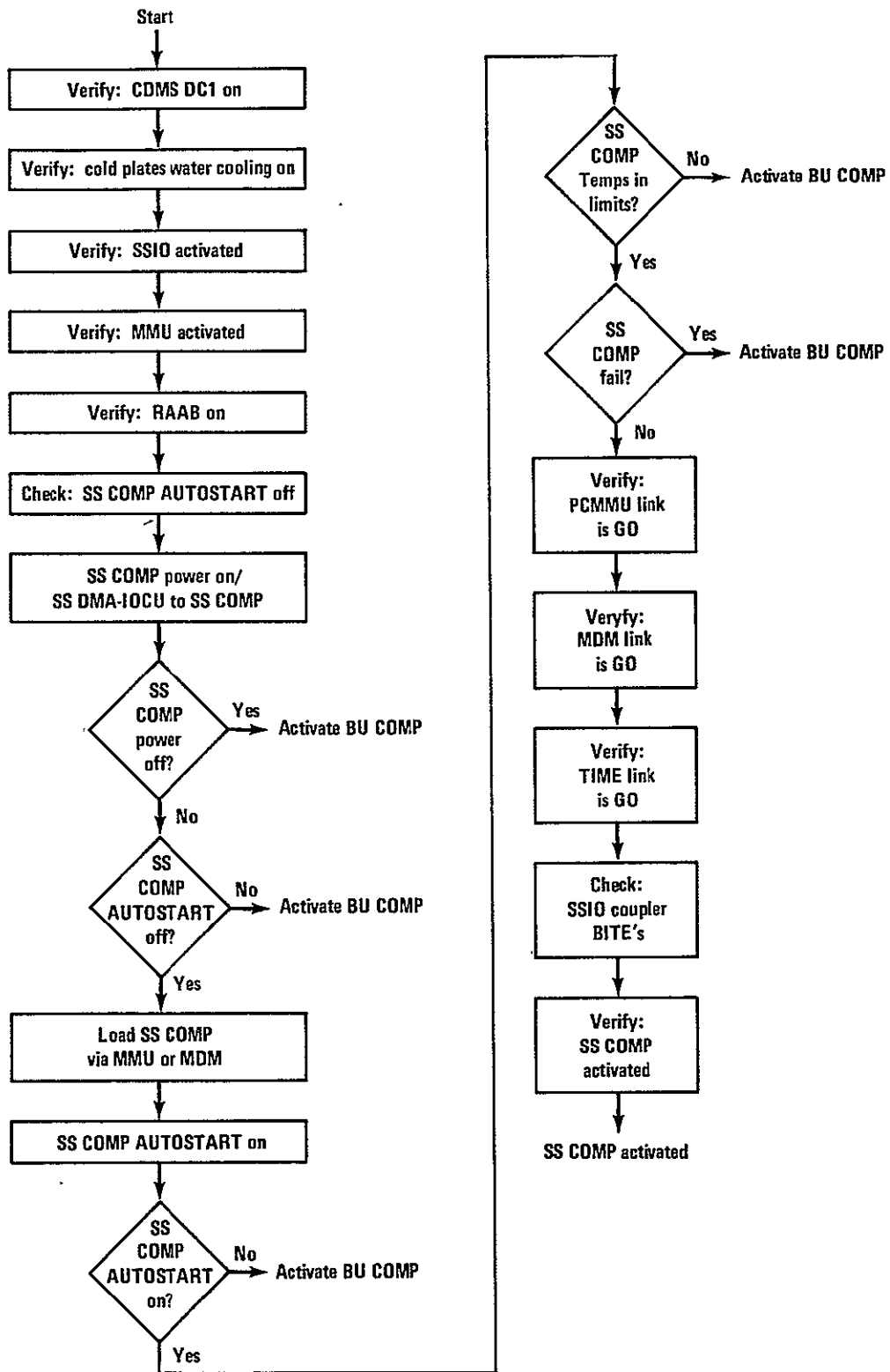
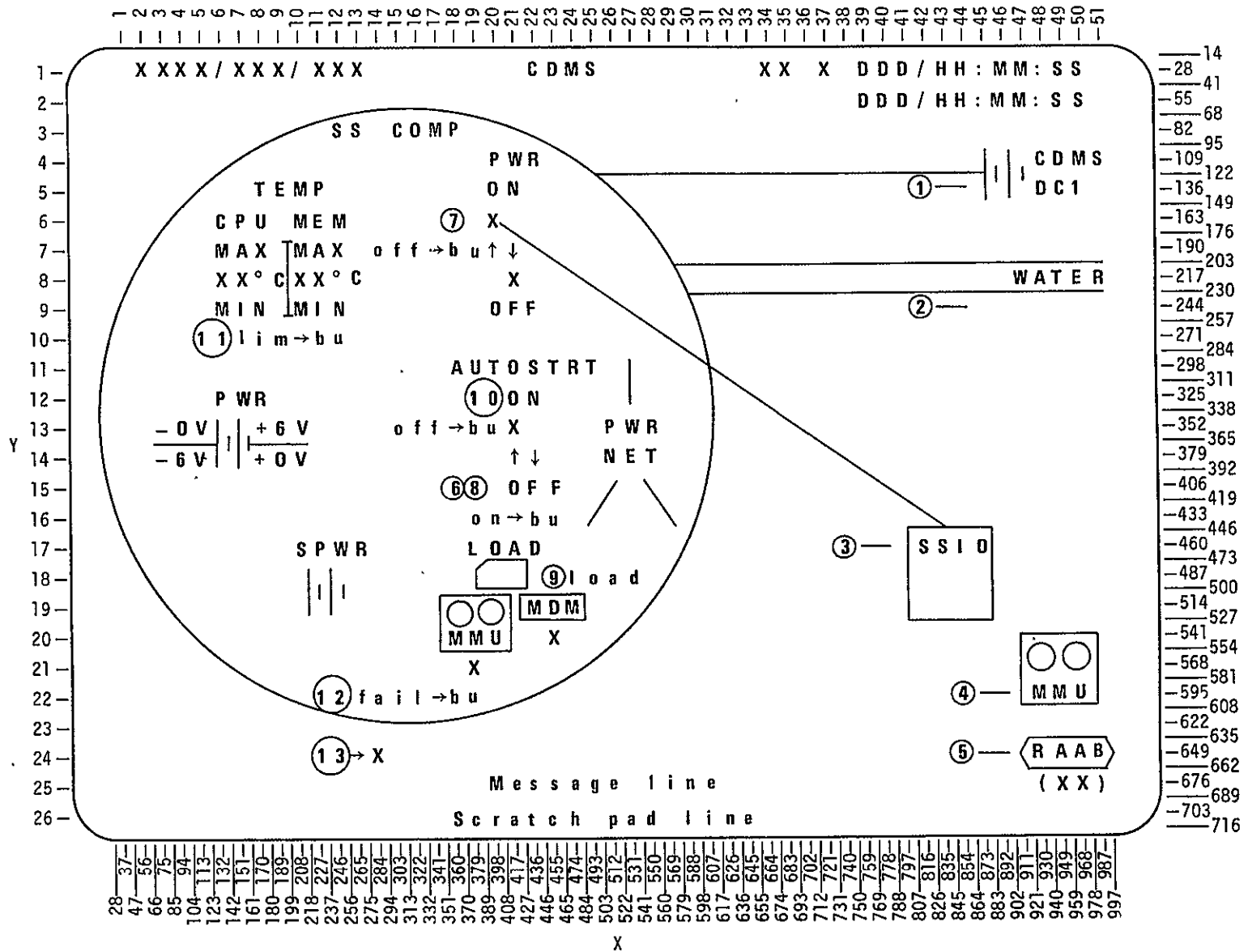
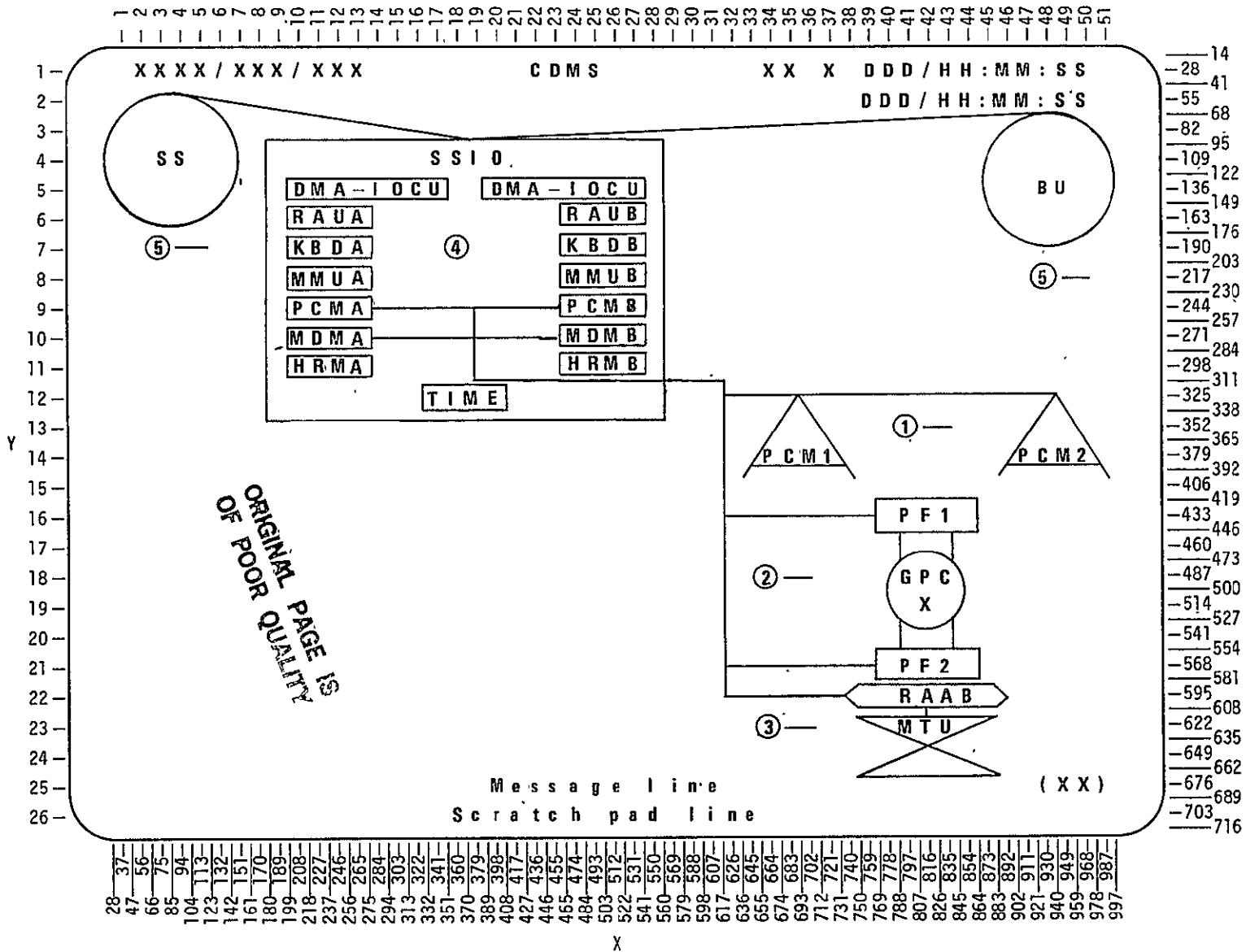

Figure 10.- SS COMP activation flow chart.



(a) Initial display.

Figure 11.- SS COMP activation displays.



(b) Concluding display.

Figure 11.- Concluded.

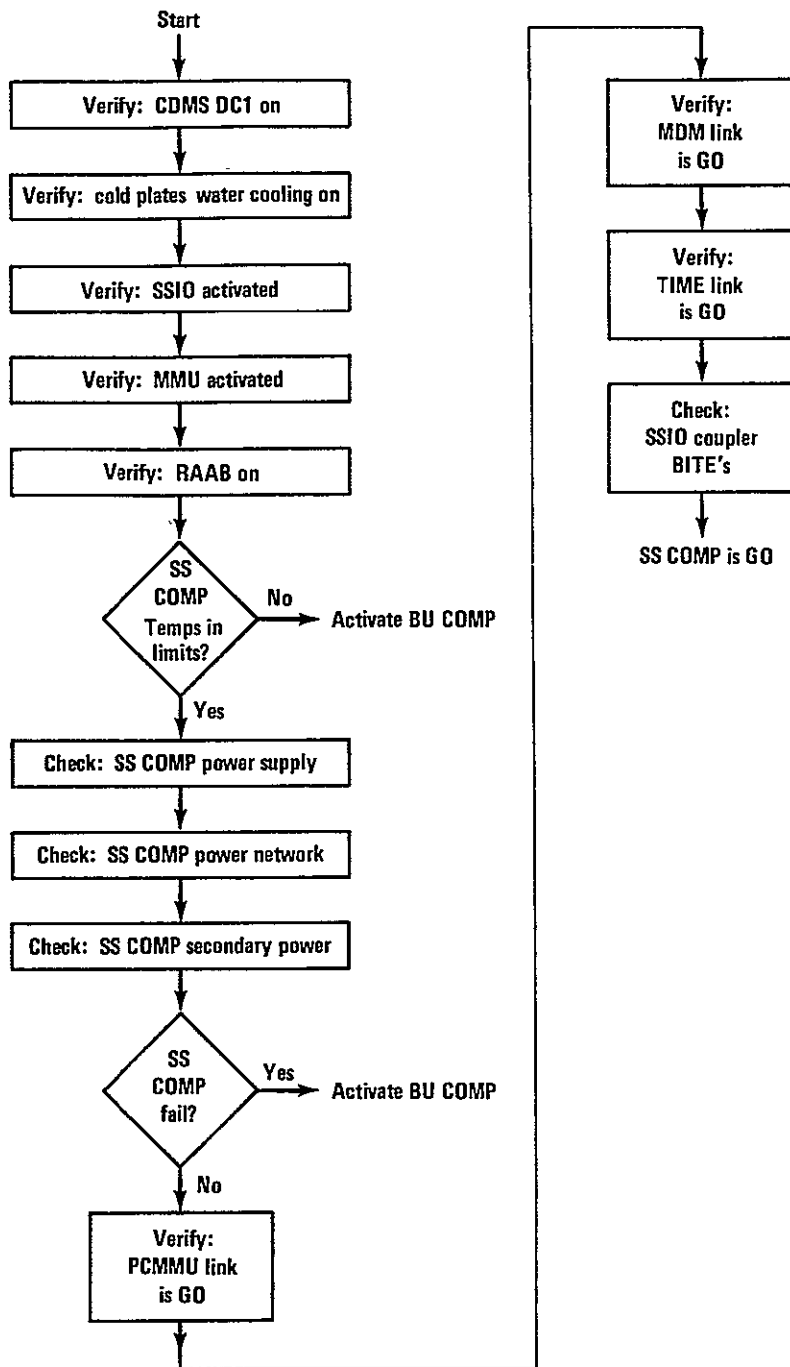
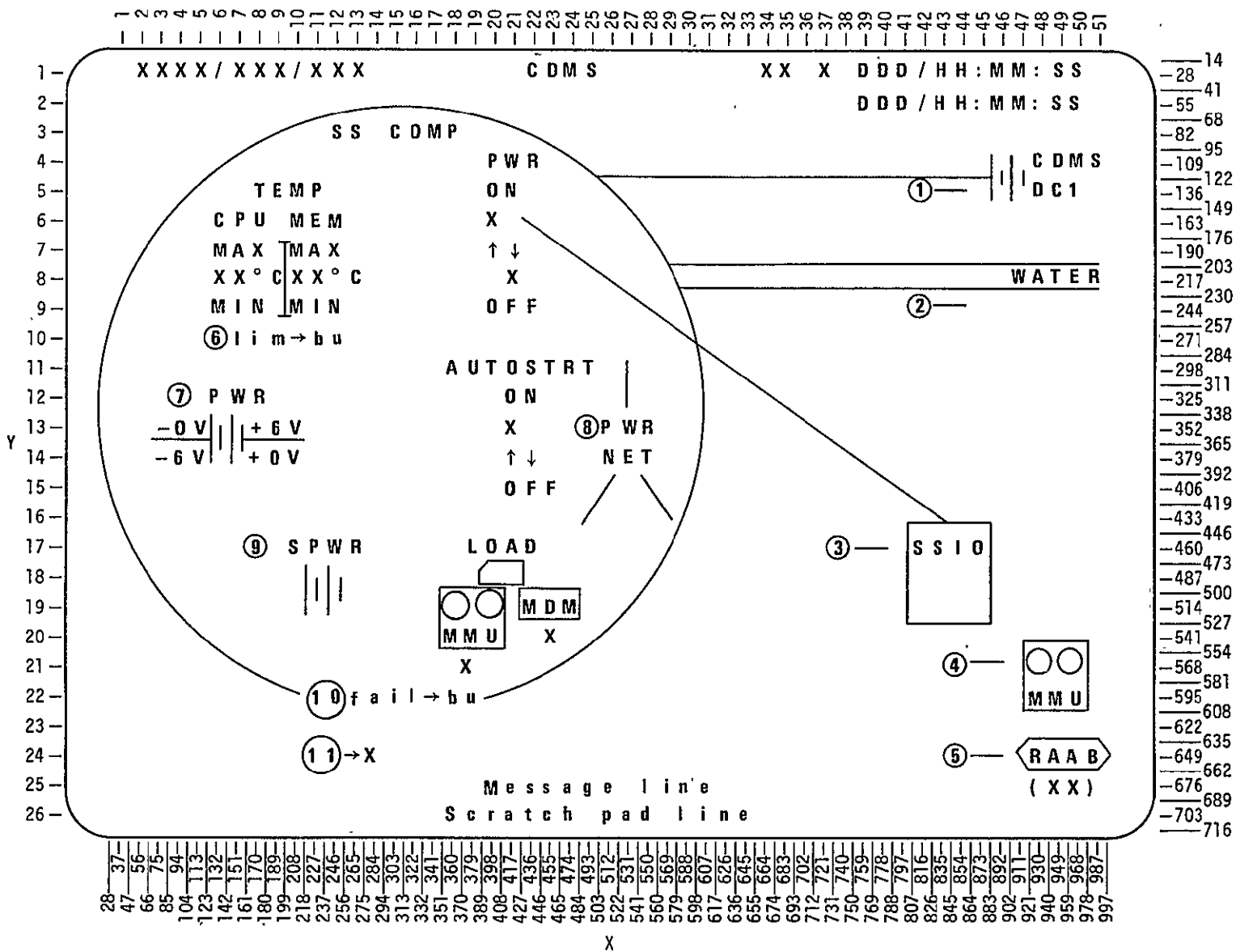

Figure 12.- SS COMP monitoring and controlling flow chart.



ORIGINAL PAGE 158
 OF POOR QUALITY

(a) Initial display.

Figure 13.- SS COMP monitoring and controlling displays.

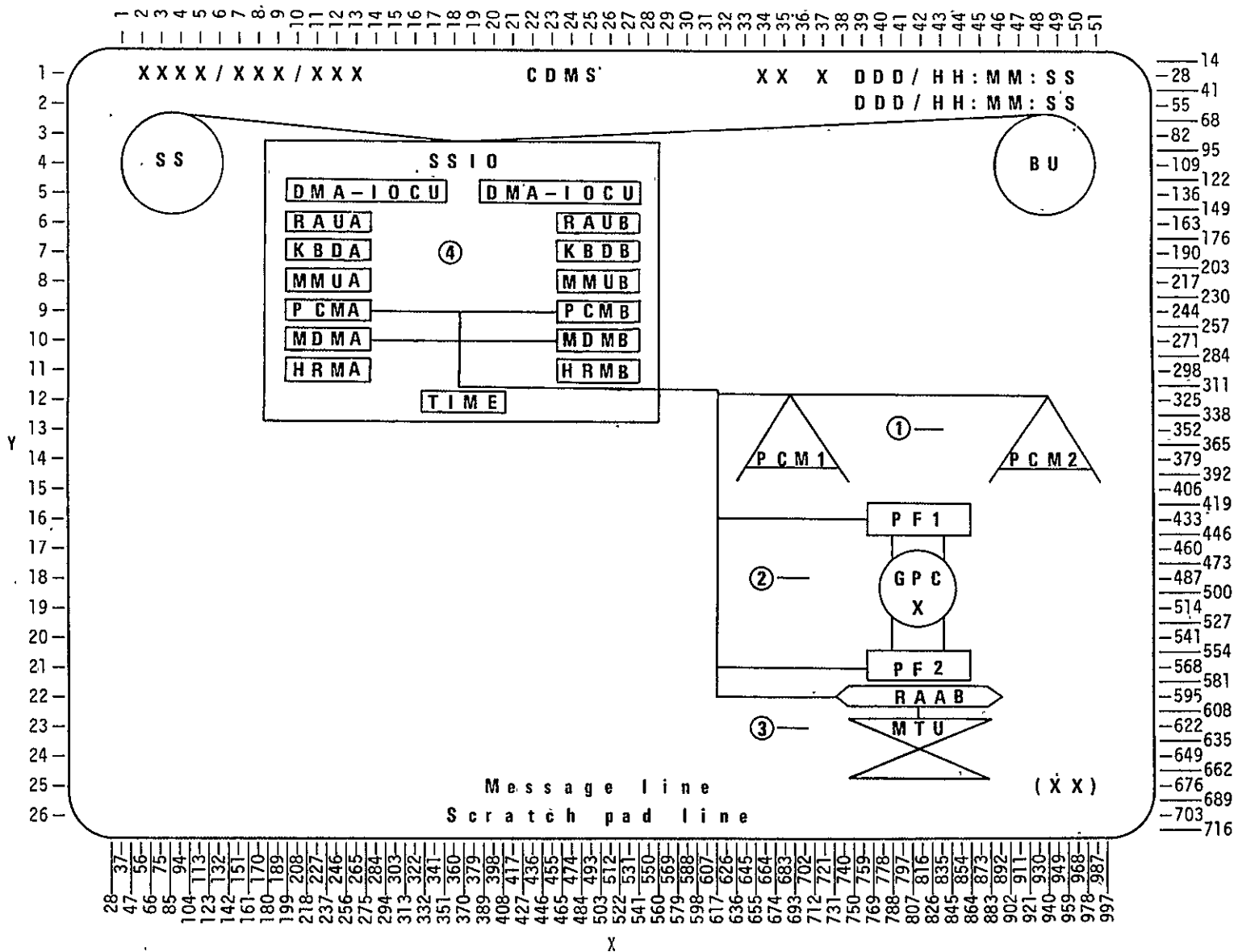

(b) Concluding display.

Figure 13.- Concluded.

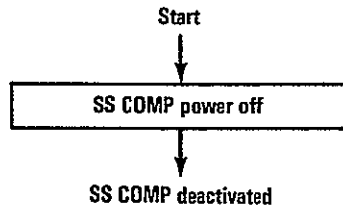

Figure 14.- SS COMP deactivation flow chart.

ORIGINAL PAGE IS
OF POOR QUALITY

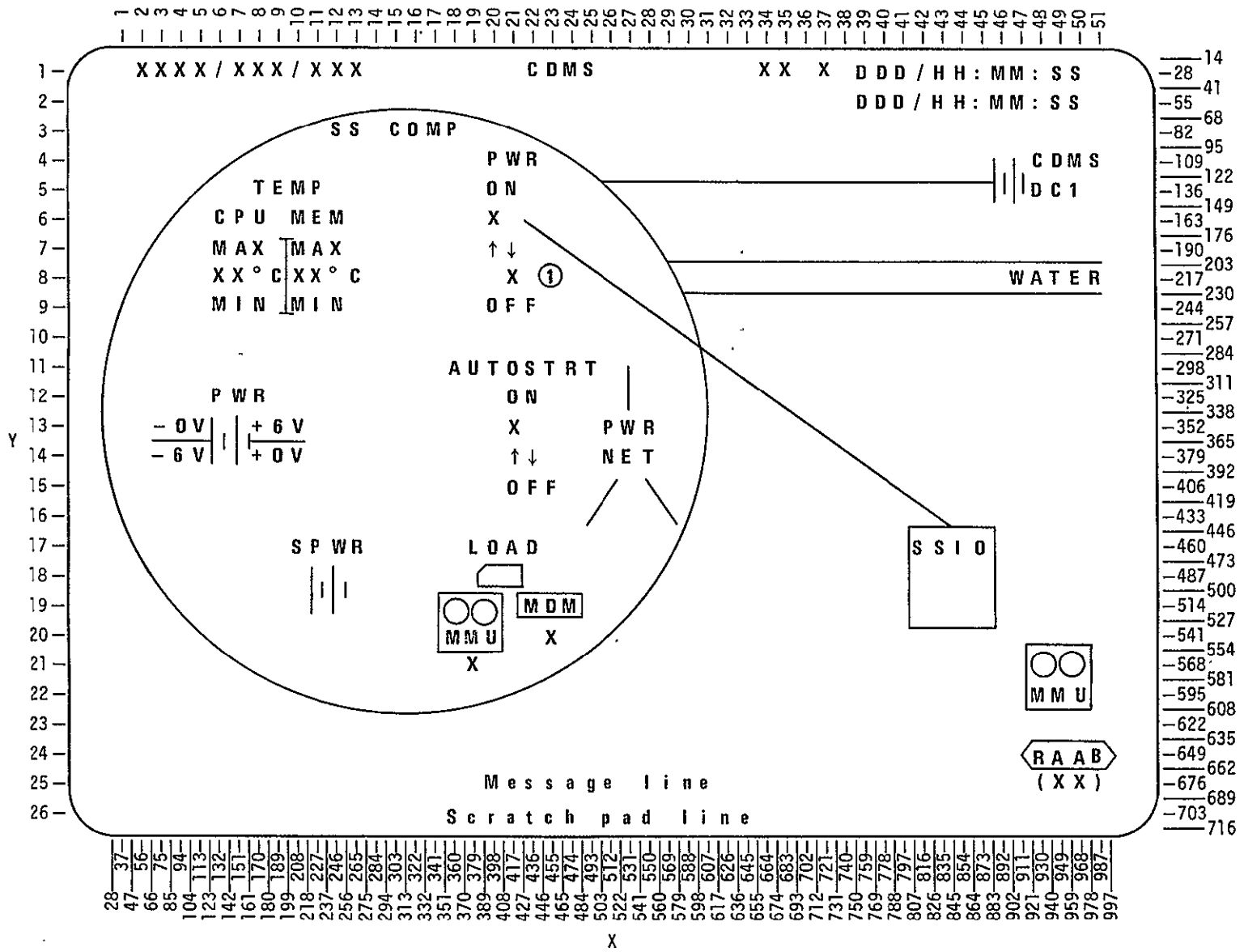

Figure 15. SS COMP deactivation display.

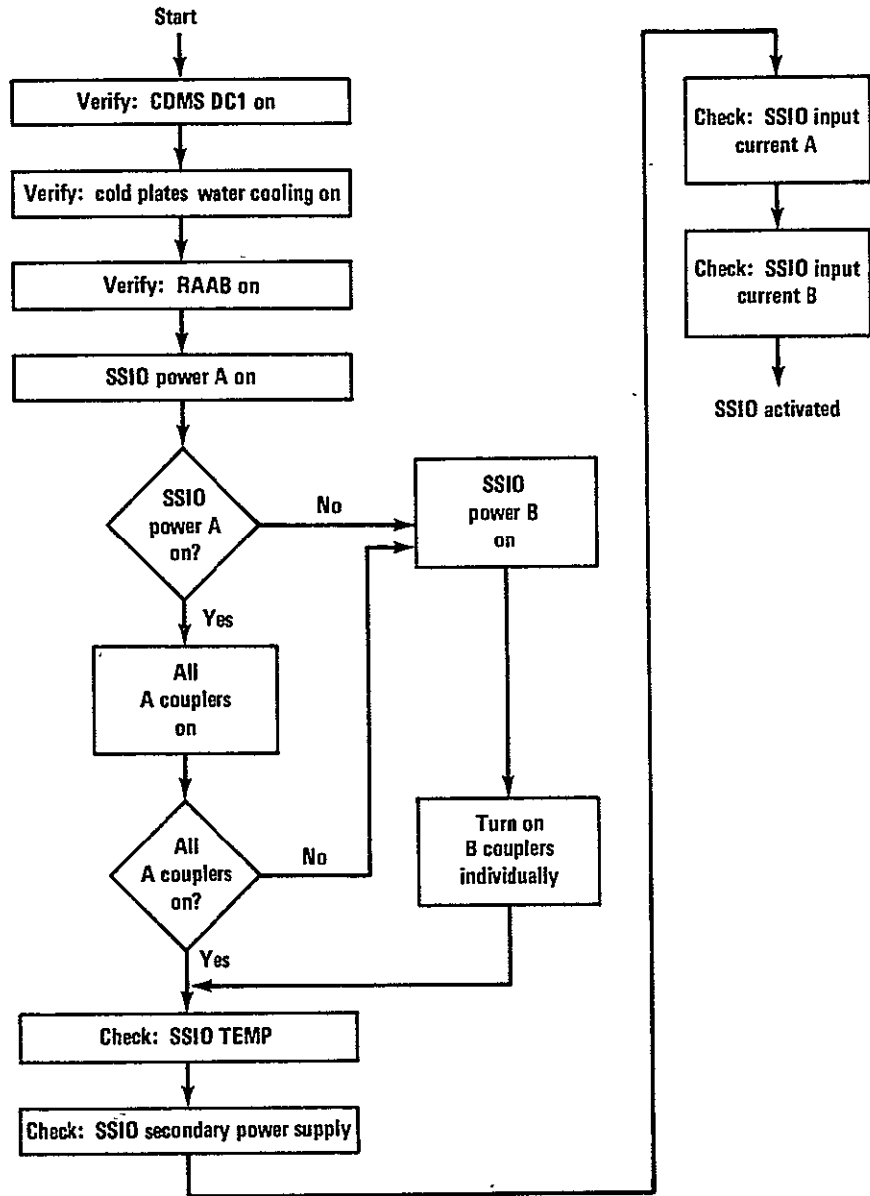

Figure 16.- SSIO activation flow chart.

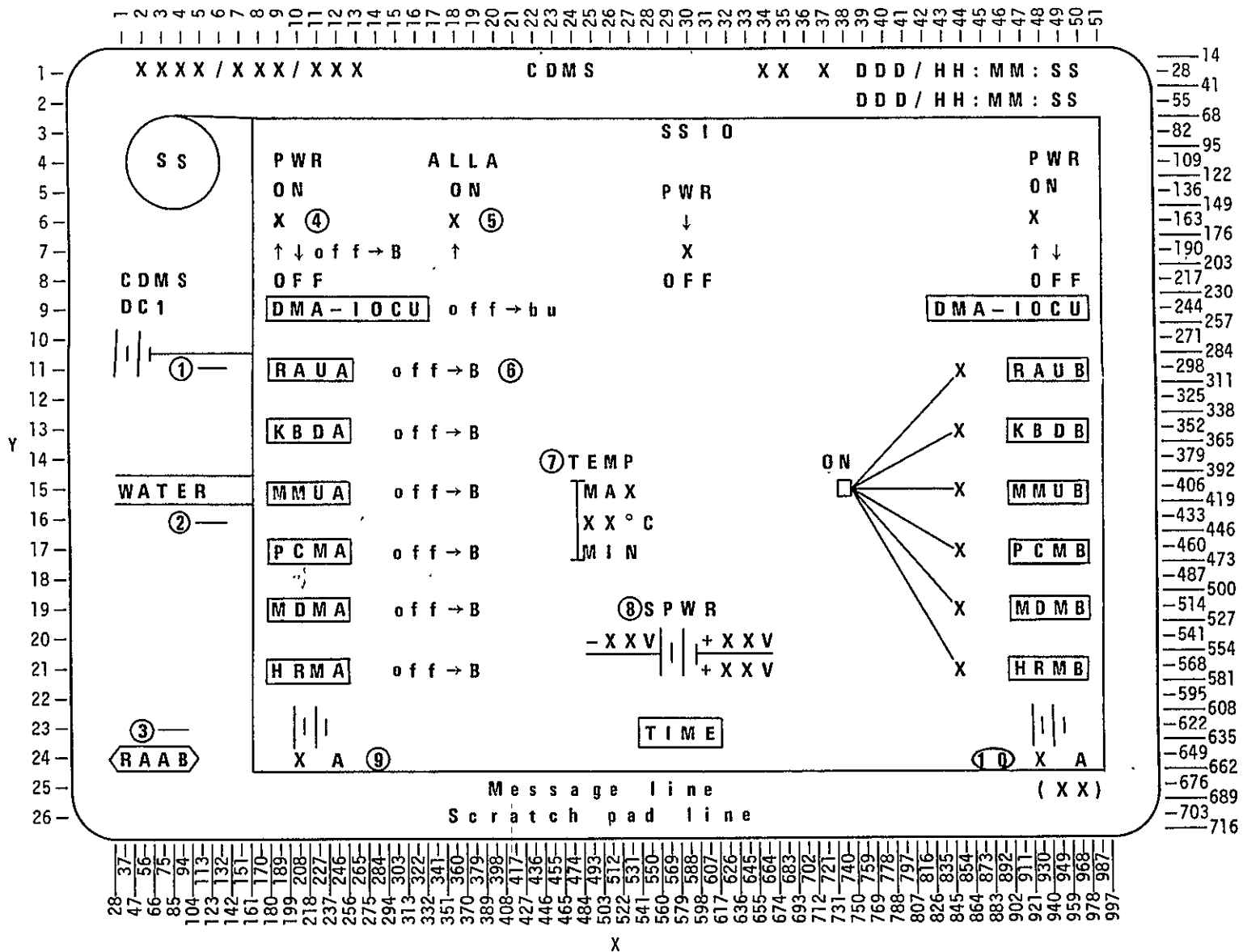

Figure 17.- SSIO activation display.

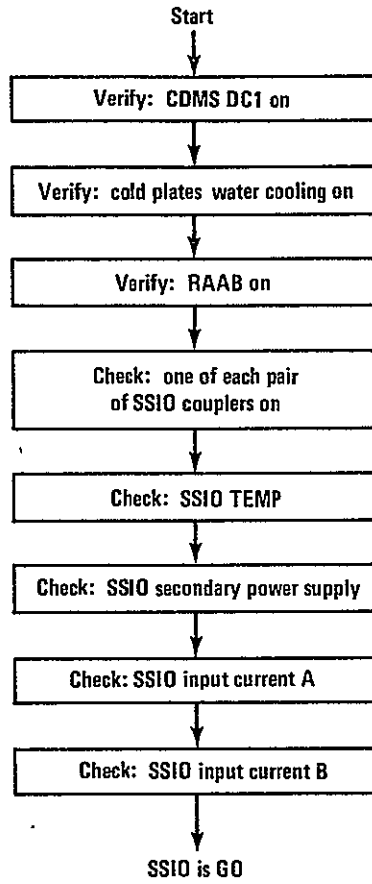

Figure 18.- SSIO monitoring and controlling flow chart.

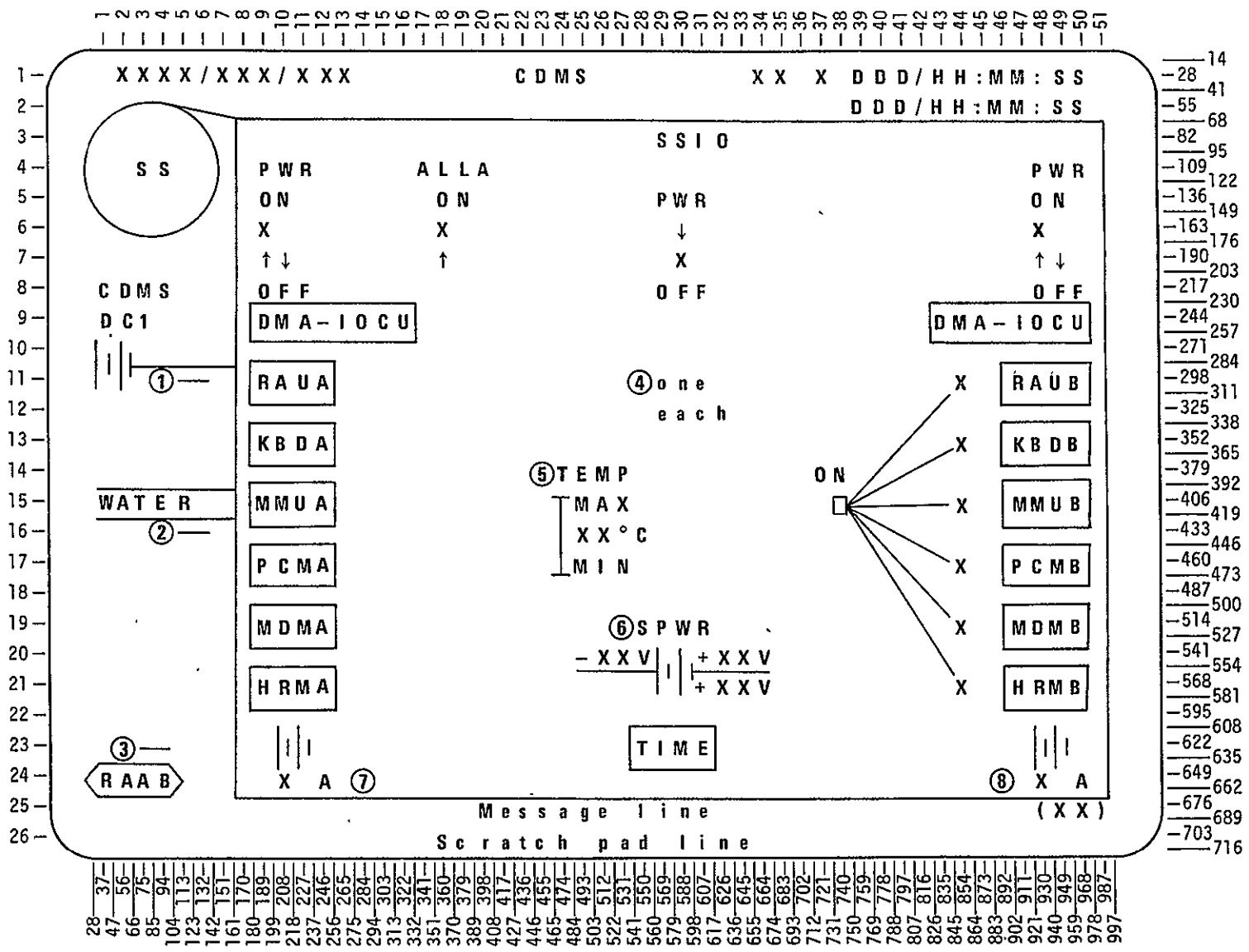

Figure 19.- SSIO monitoring and controlling display.

ORIGINAL PAGE IS
OF POOR QUALITY

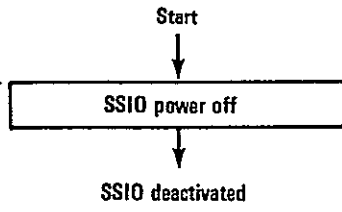

Figure 20.- SSIO deactivation flow chart.

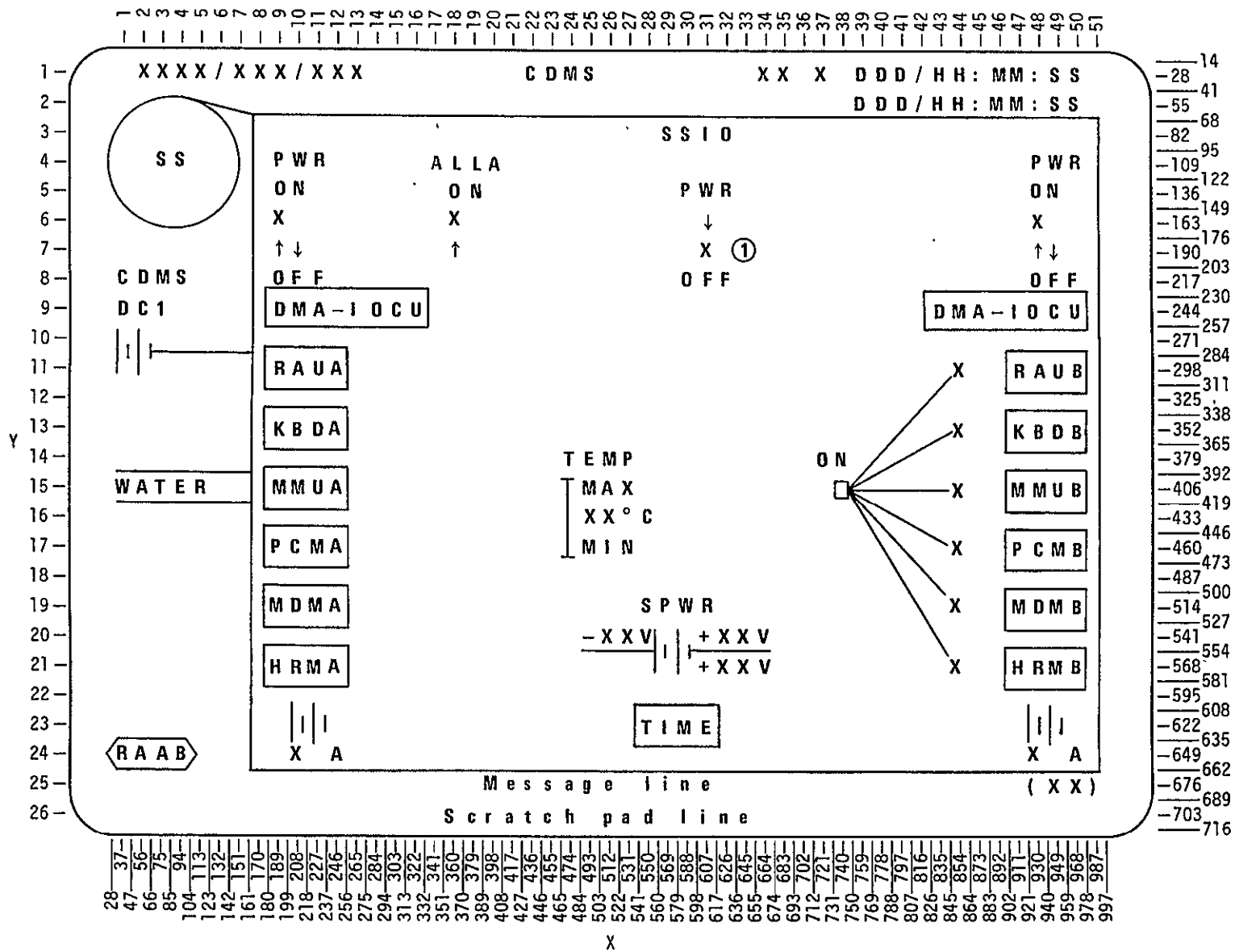

Figure 21.- SSIO deactivation display.

ORIGINAL PAGE IS
OF POOR QUALITY

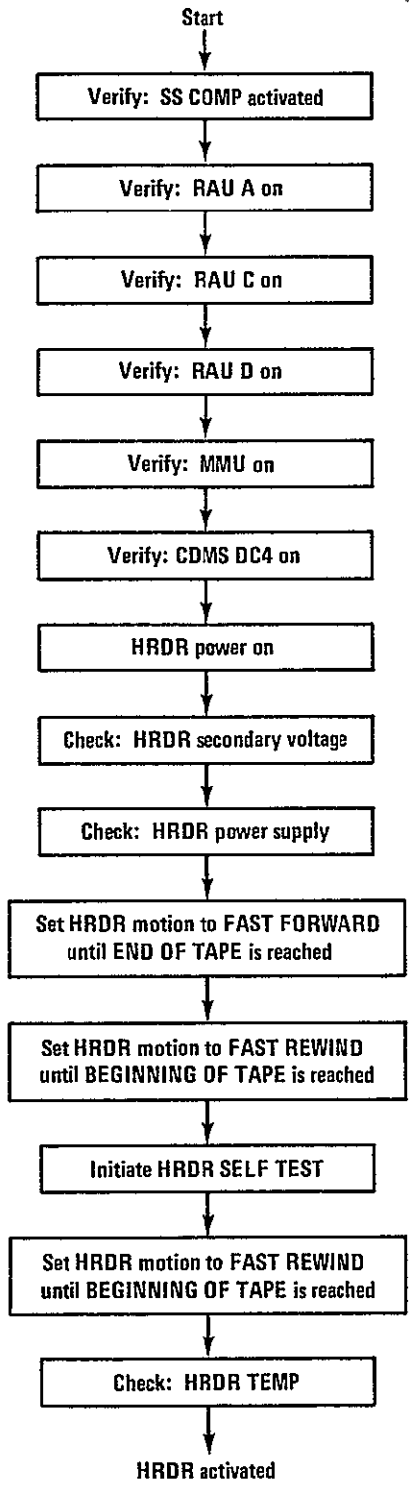

Figure 22.- HRDR activation flow chart.

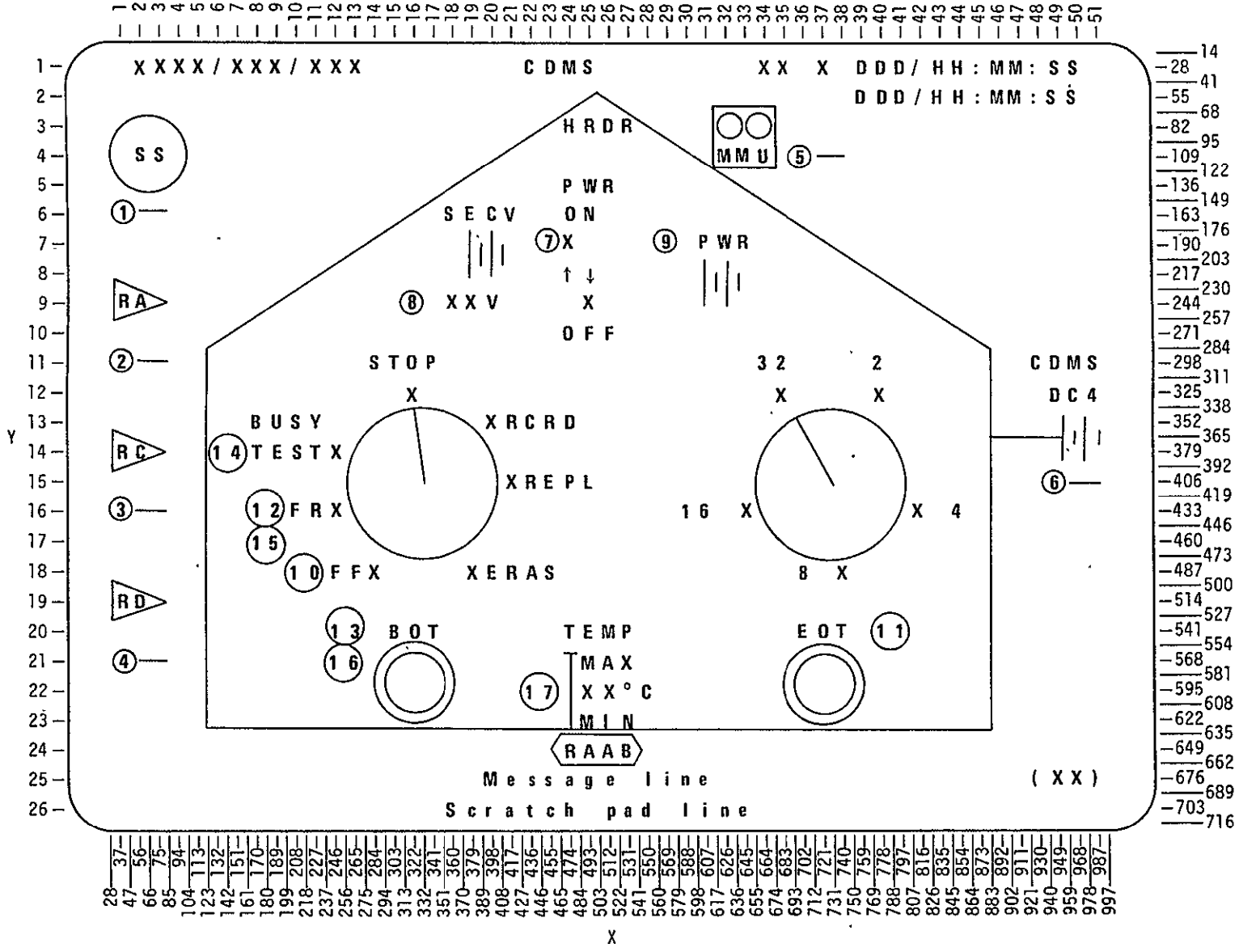

Figure 23.- HRDR activation display.

ORIGINAL PAGE IS OF POOR QUALITY

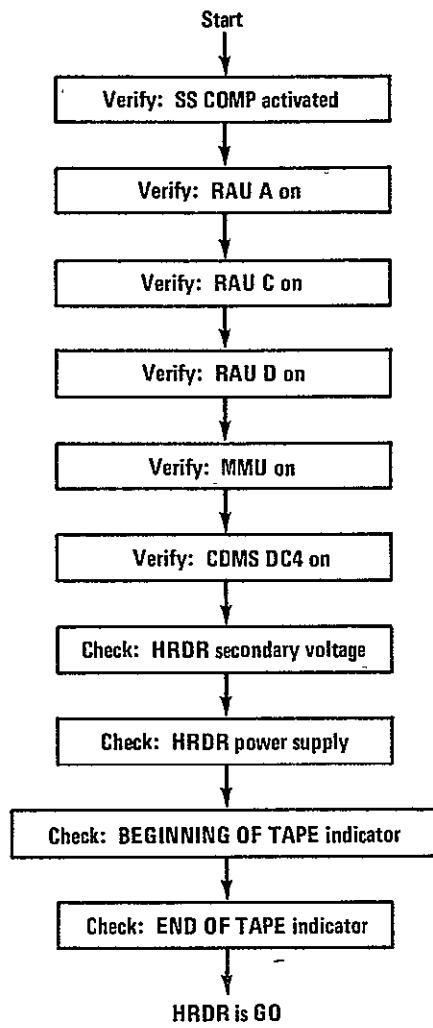

Figure 24.- HRDR monitoring and controlling flow chart.

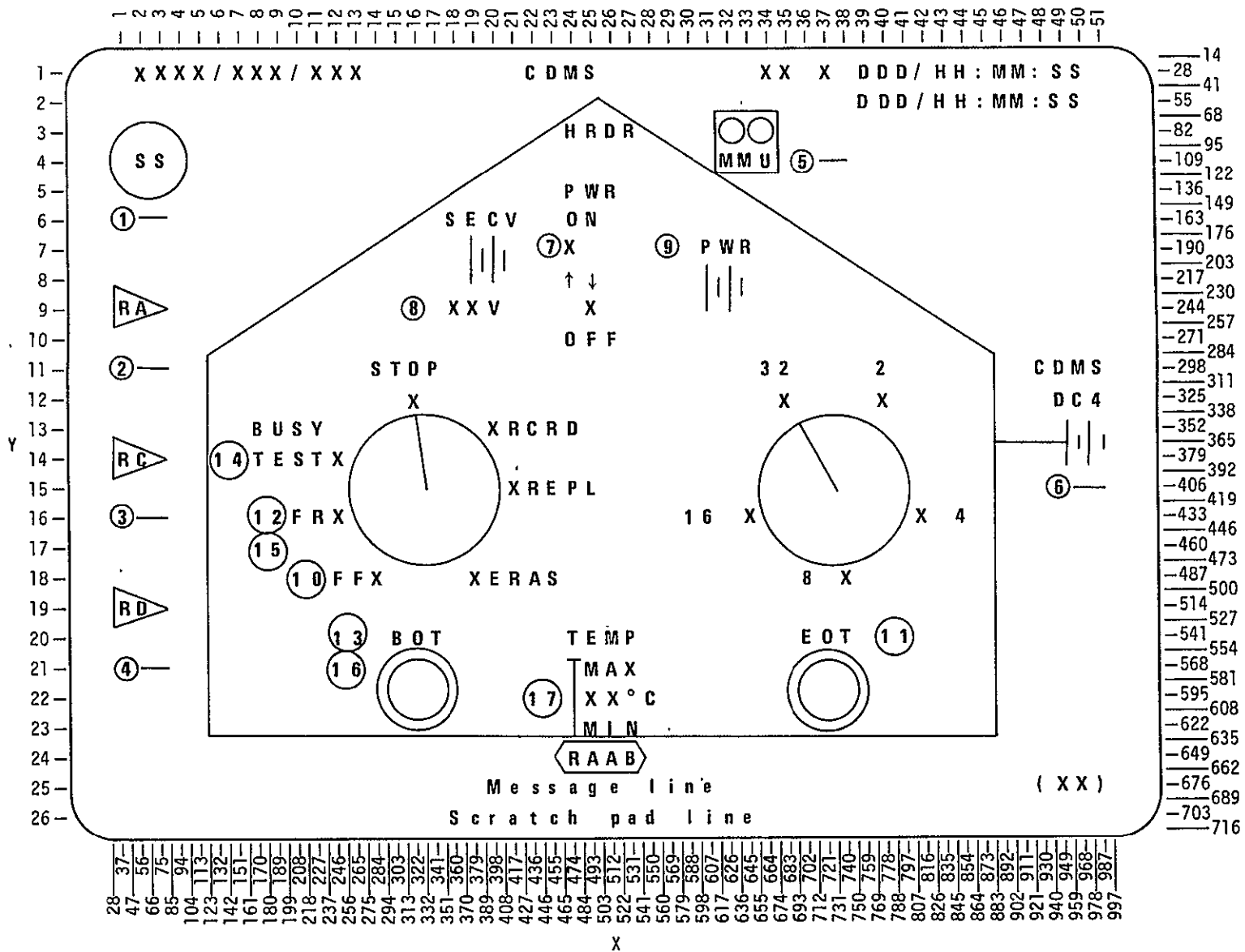

Figure 25.- HRDR monitoring and controlling display.

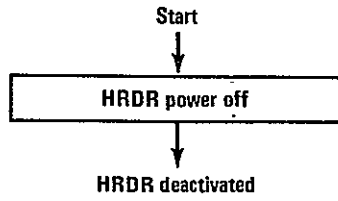

Figure 26.- HRDR deactivation flow chart.

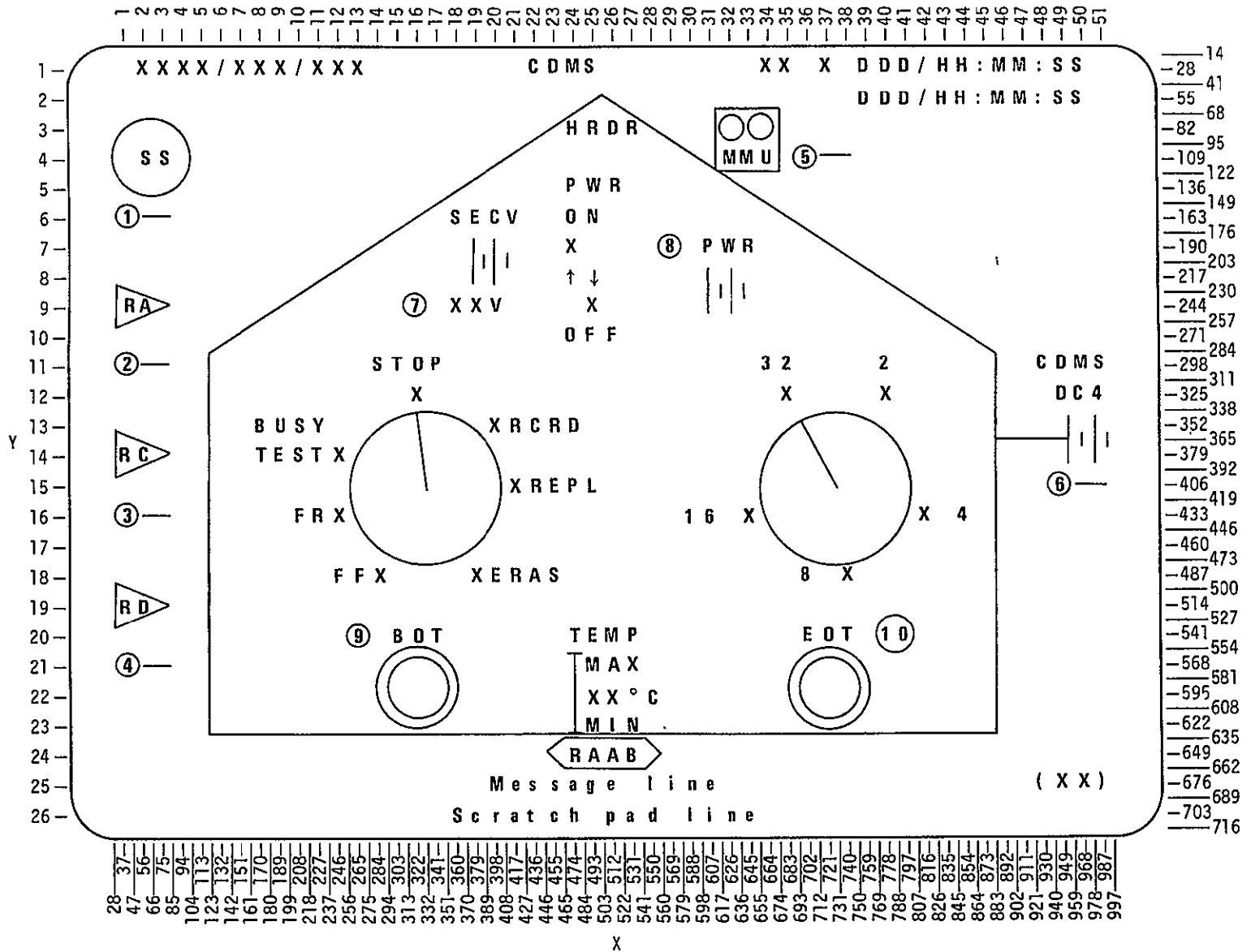

Figure 27.- HRDR deactivation display.

ORIGINAL PAGE IS OF POOR QUALITY

ORIGINAL PAGE IS OF POOR QUALITY

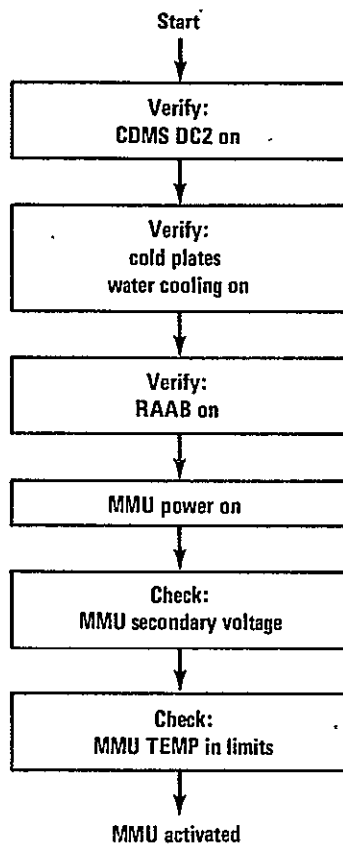

Figure 28.- MMU activation flow chart.

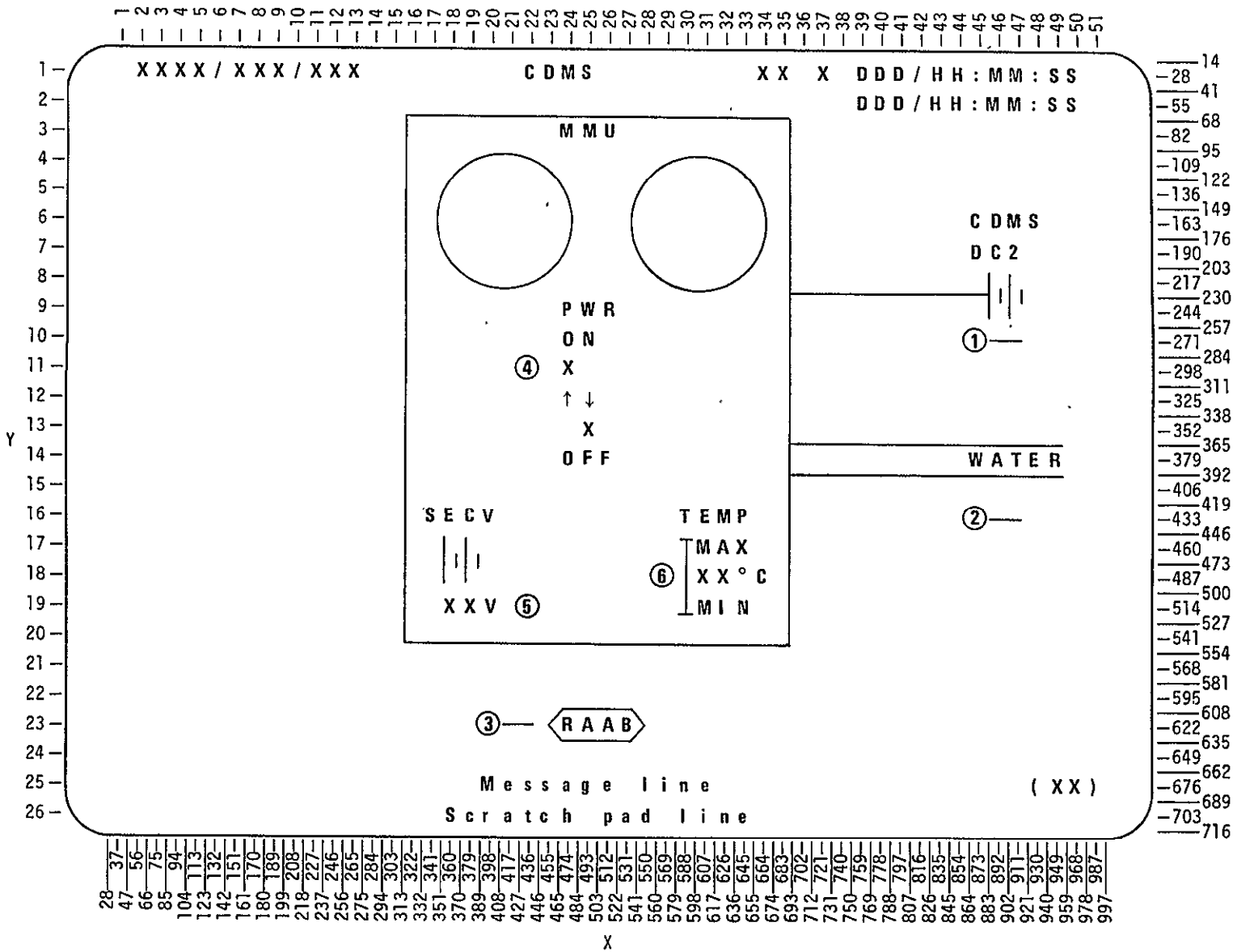

Figure 29.- MMU activation display.

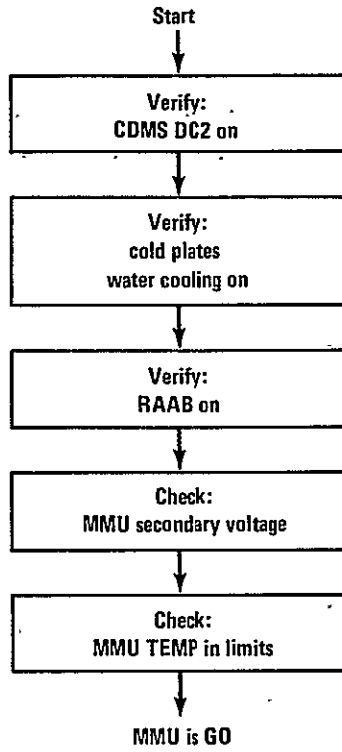

Figure 30.- MMU monitoring and controlling flow chart.

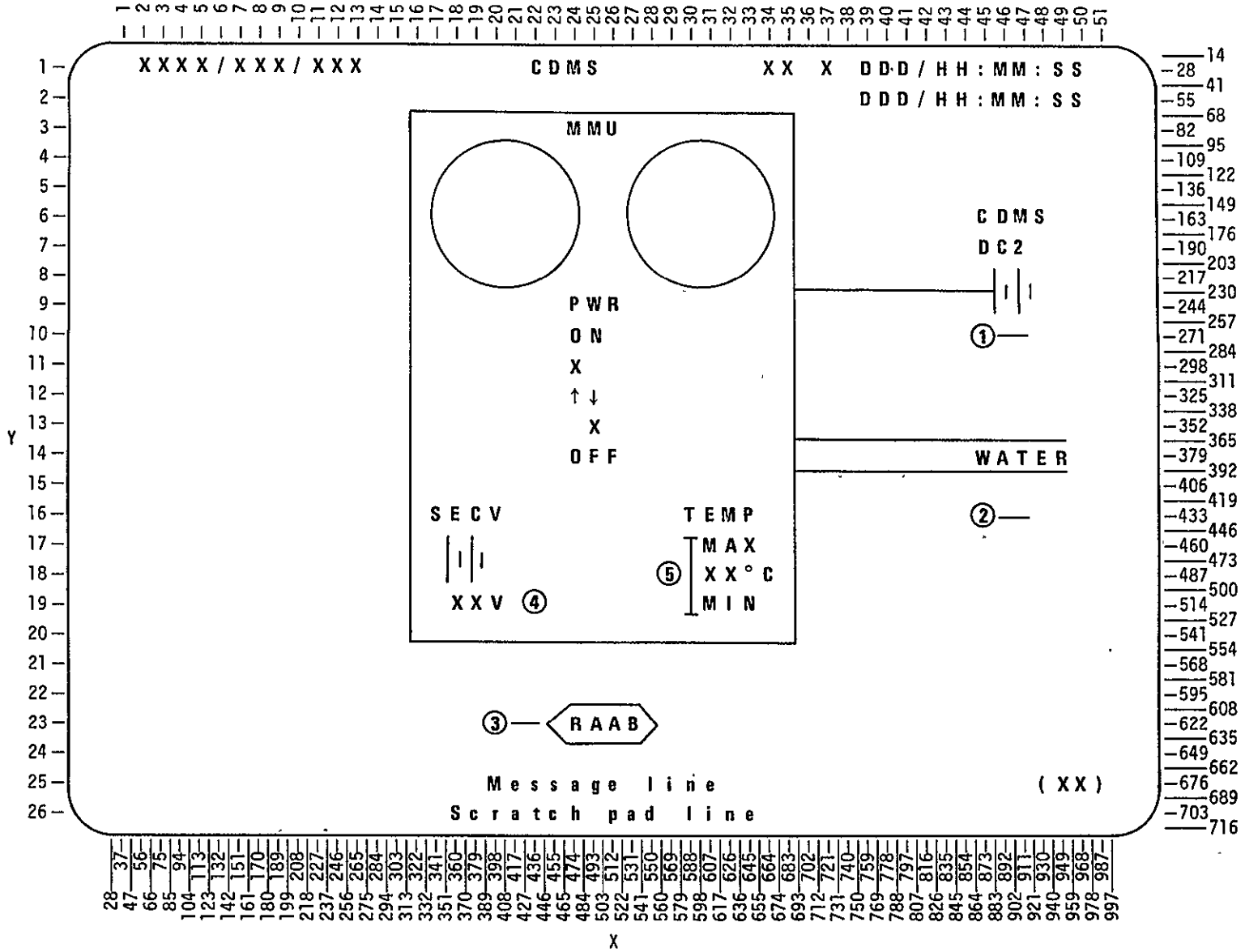

Figure 31.- MMU monitoring and controlling display.

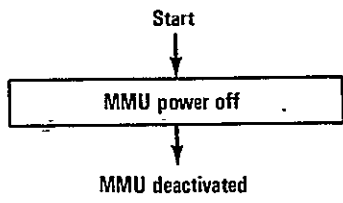

Figure 32.- MMU deactivation flow chart.

ORIGINAL FROM
OF POOR QUALITY

230

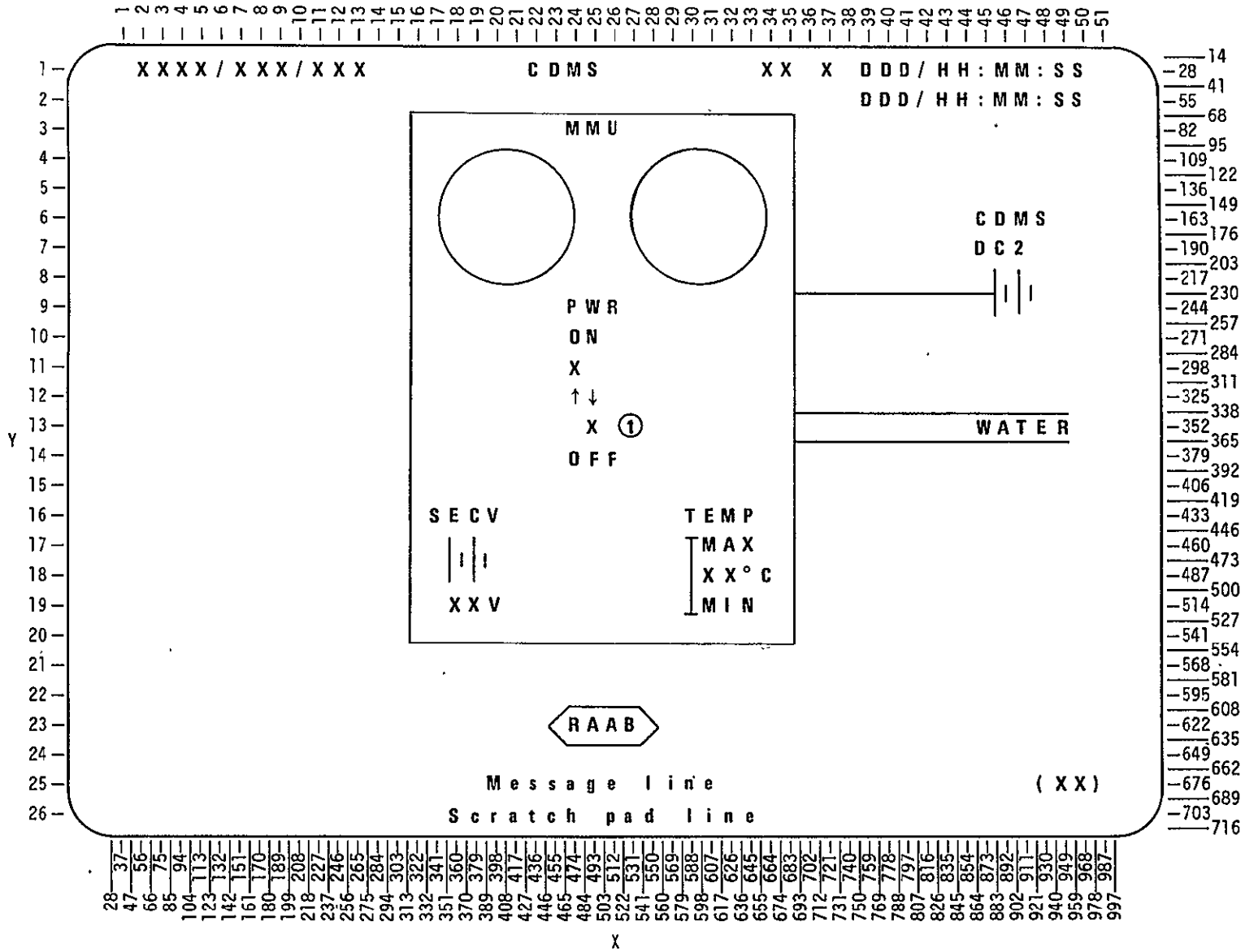

Figure 33.- MMU deactivation display.

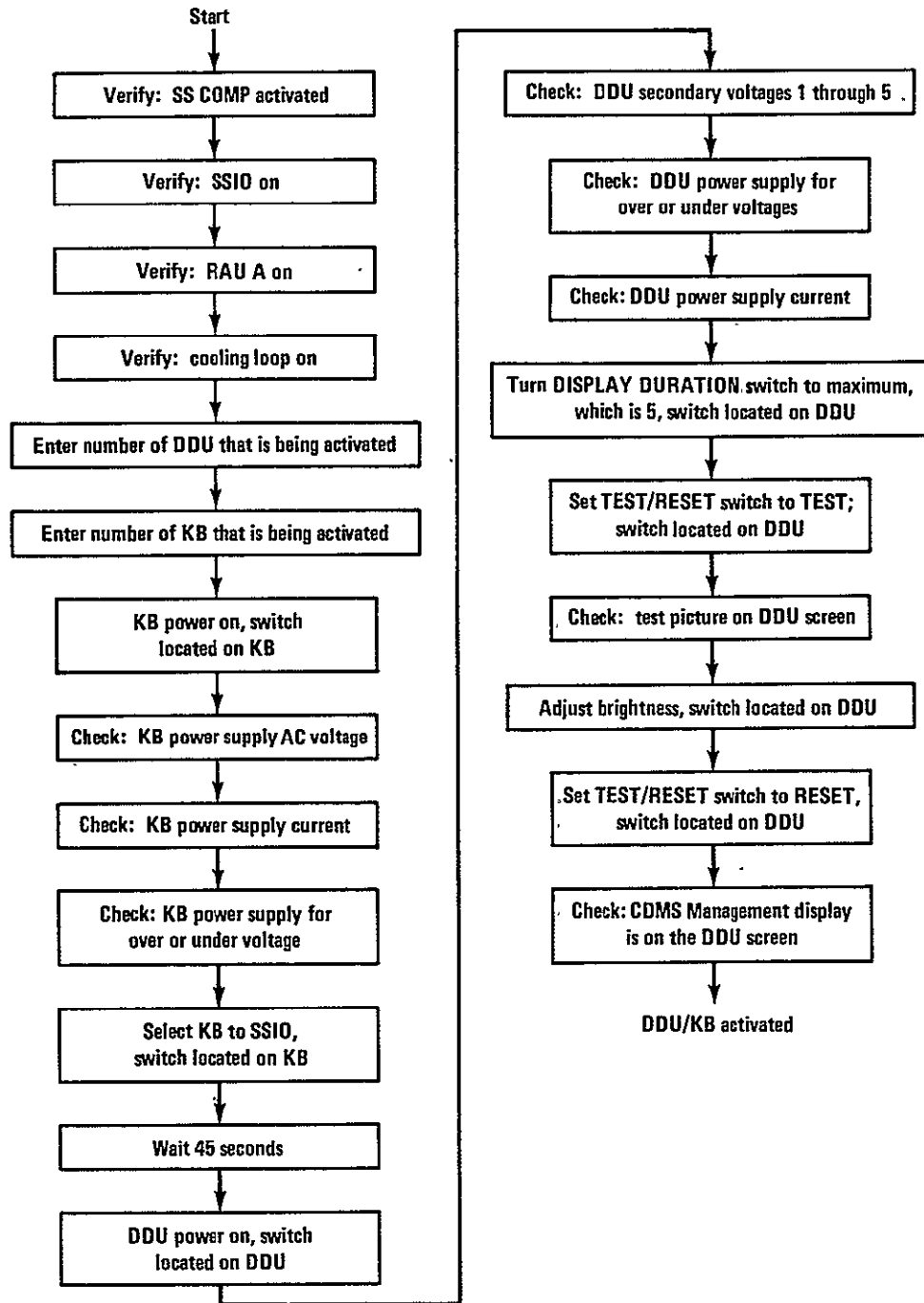

Figure 34.- DDU/KB activation flow chart..

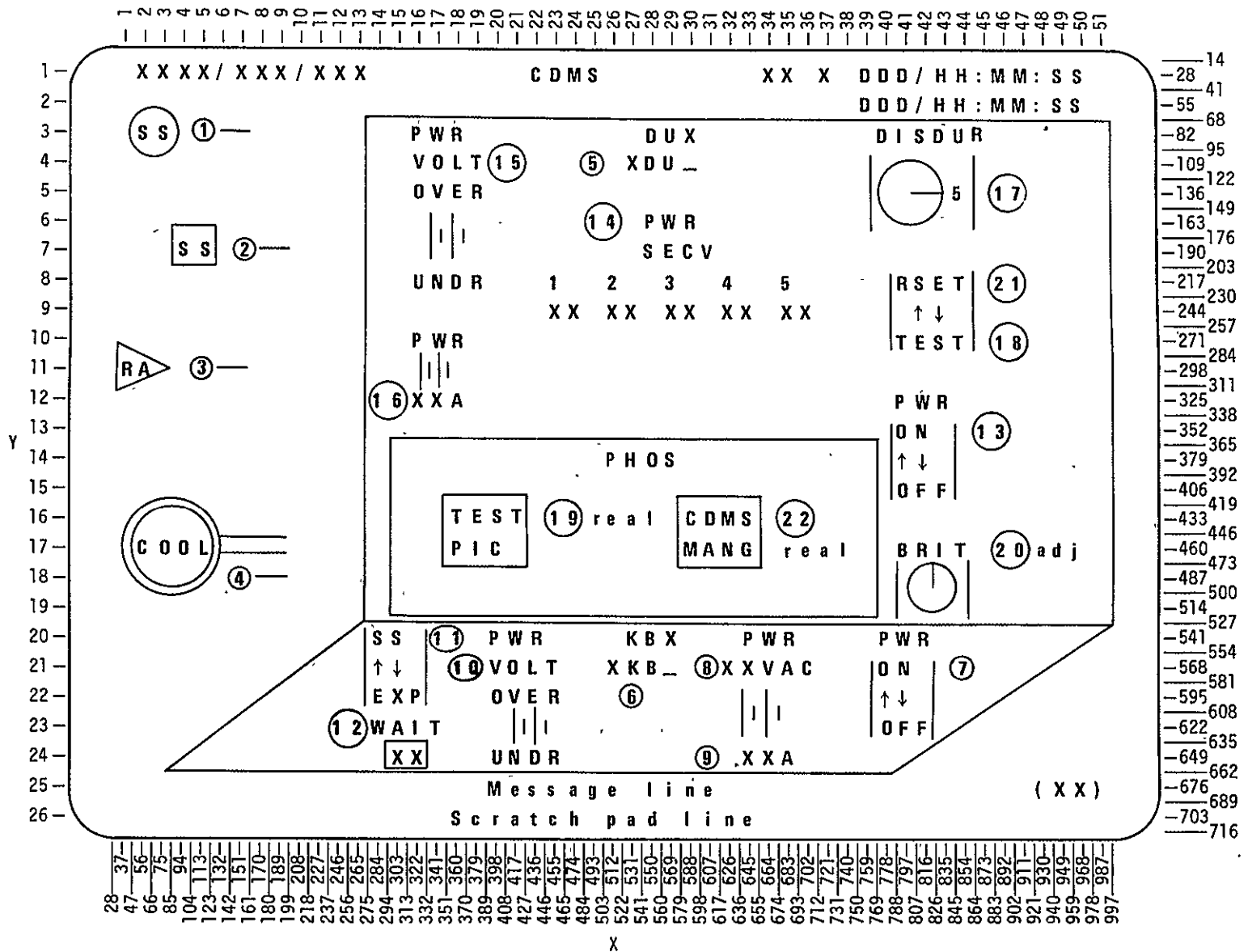

Figure 35.- DDU/KB activation display.

ORIGINAL PAGE IS OF POOR QUALITY

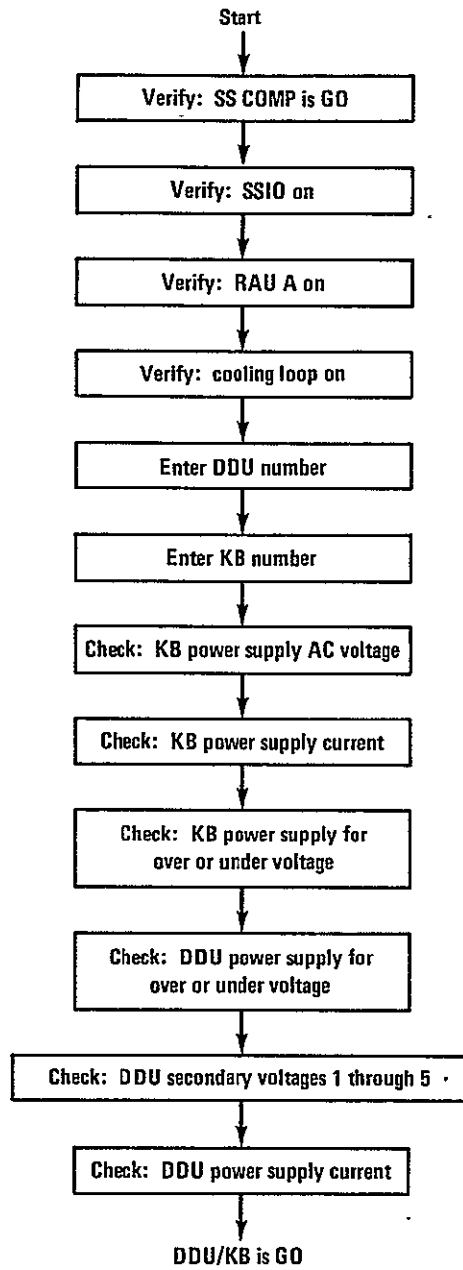

Figure 36.- DDU/KB monitoring and controlling flow chart.

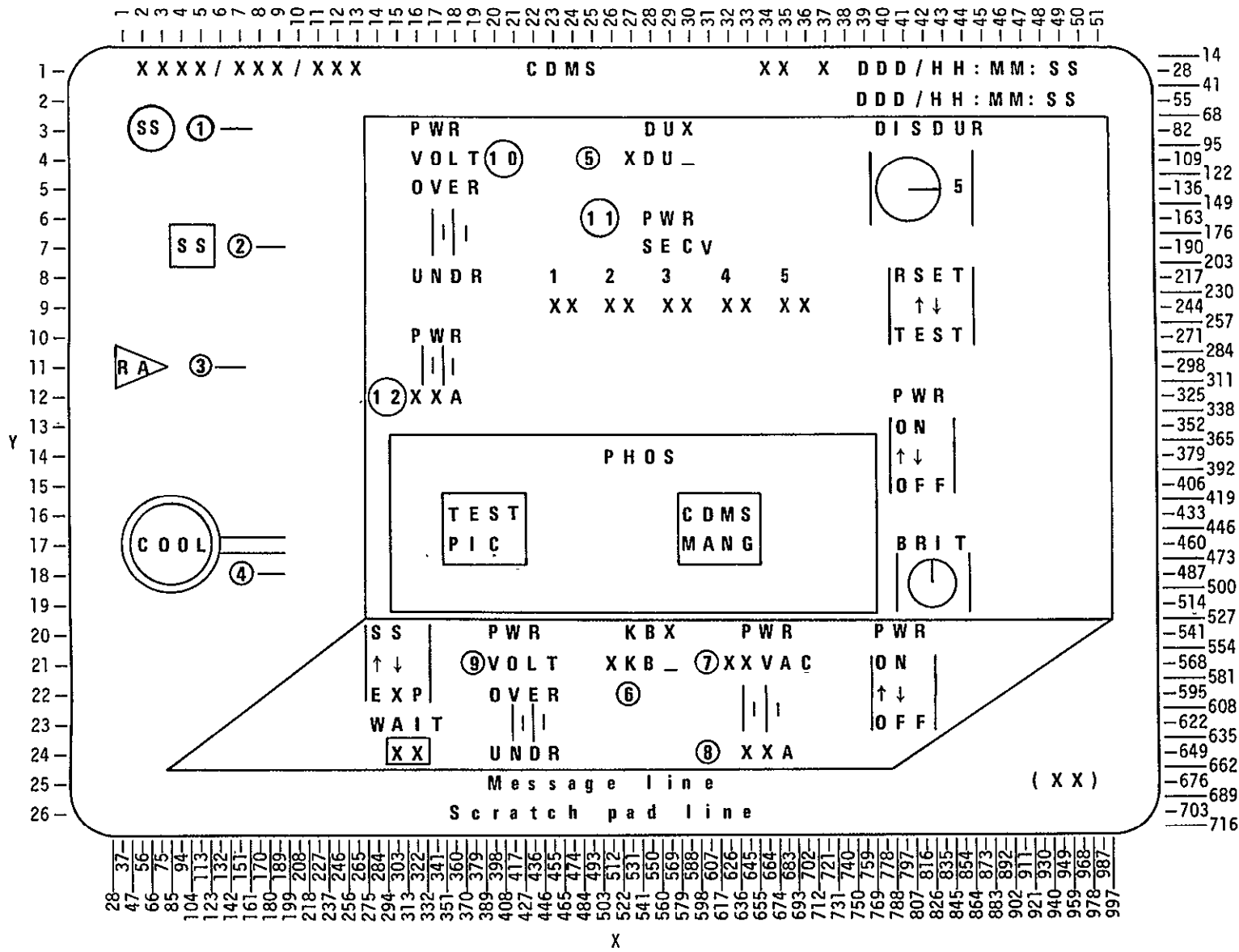

Figure 37.- DDU/KB monitoring and controlling display.

ORIGINAL PAGE IS OF POOR QUALITY

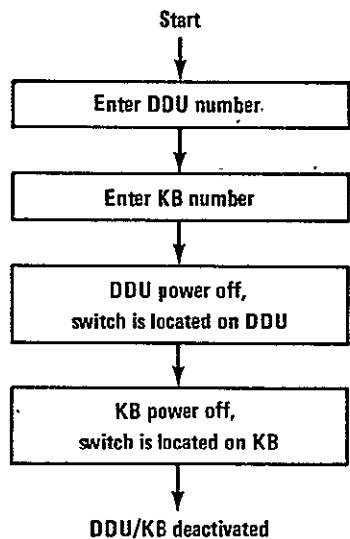

Figure 38.- DDU/KB deactivation flow chart.

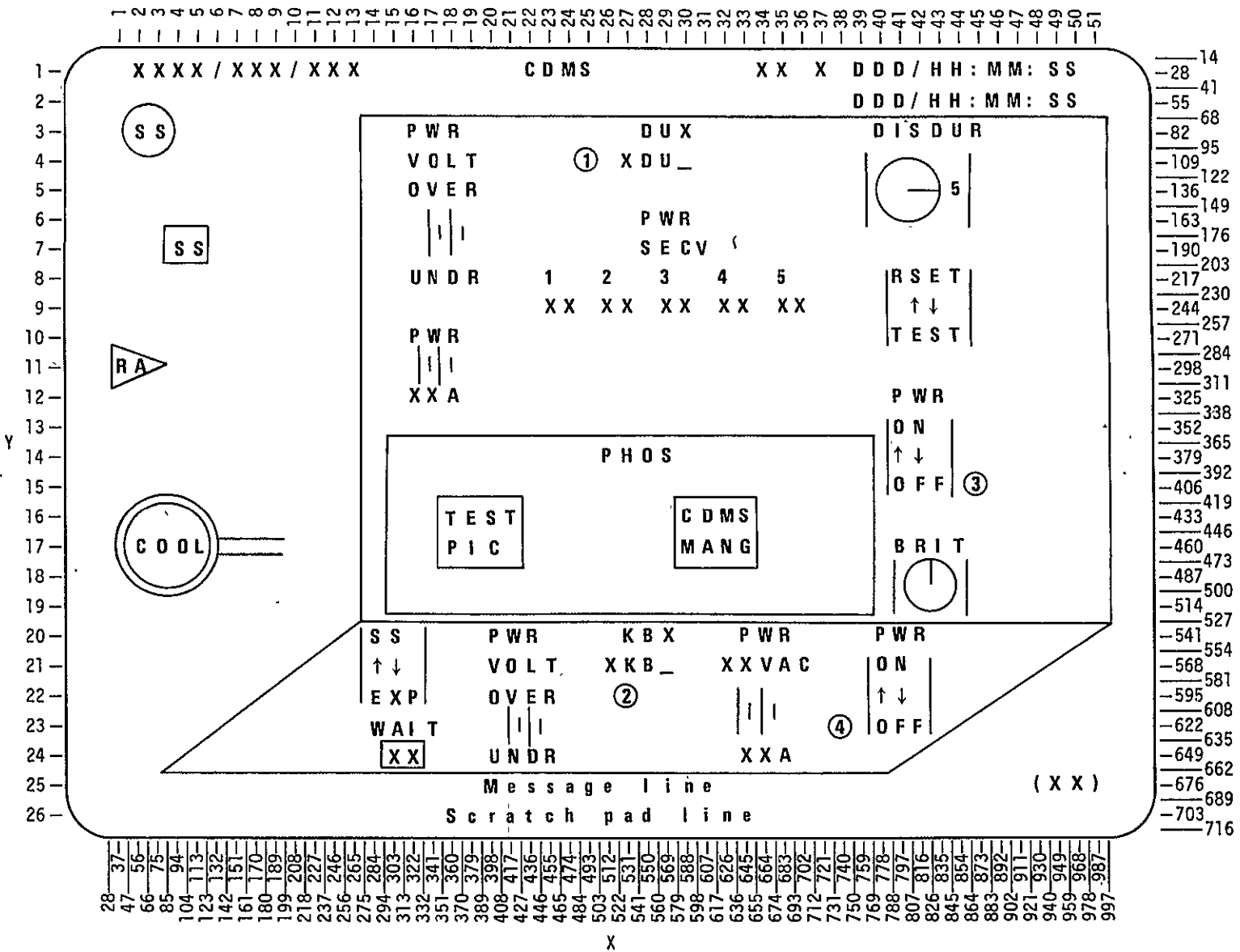

Figure 39.- DDU/KB deactivation display.

ORIGINAL PAGE IS OF POOR QUALITY

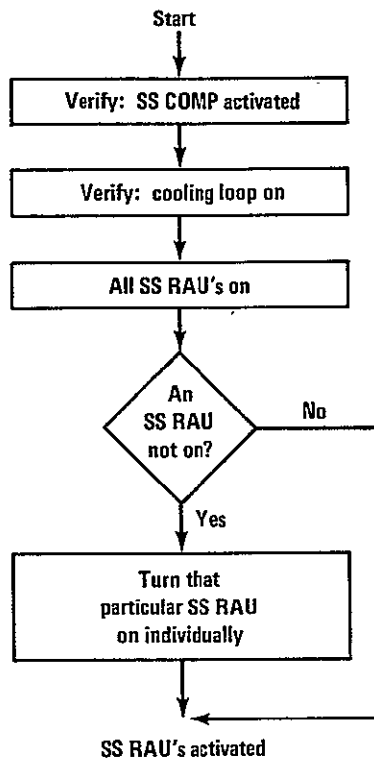

Figure 40.- SS RAU's activation flow chart.

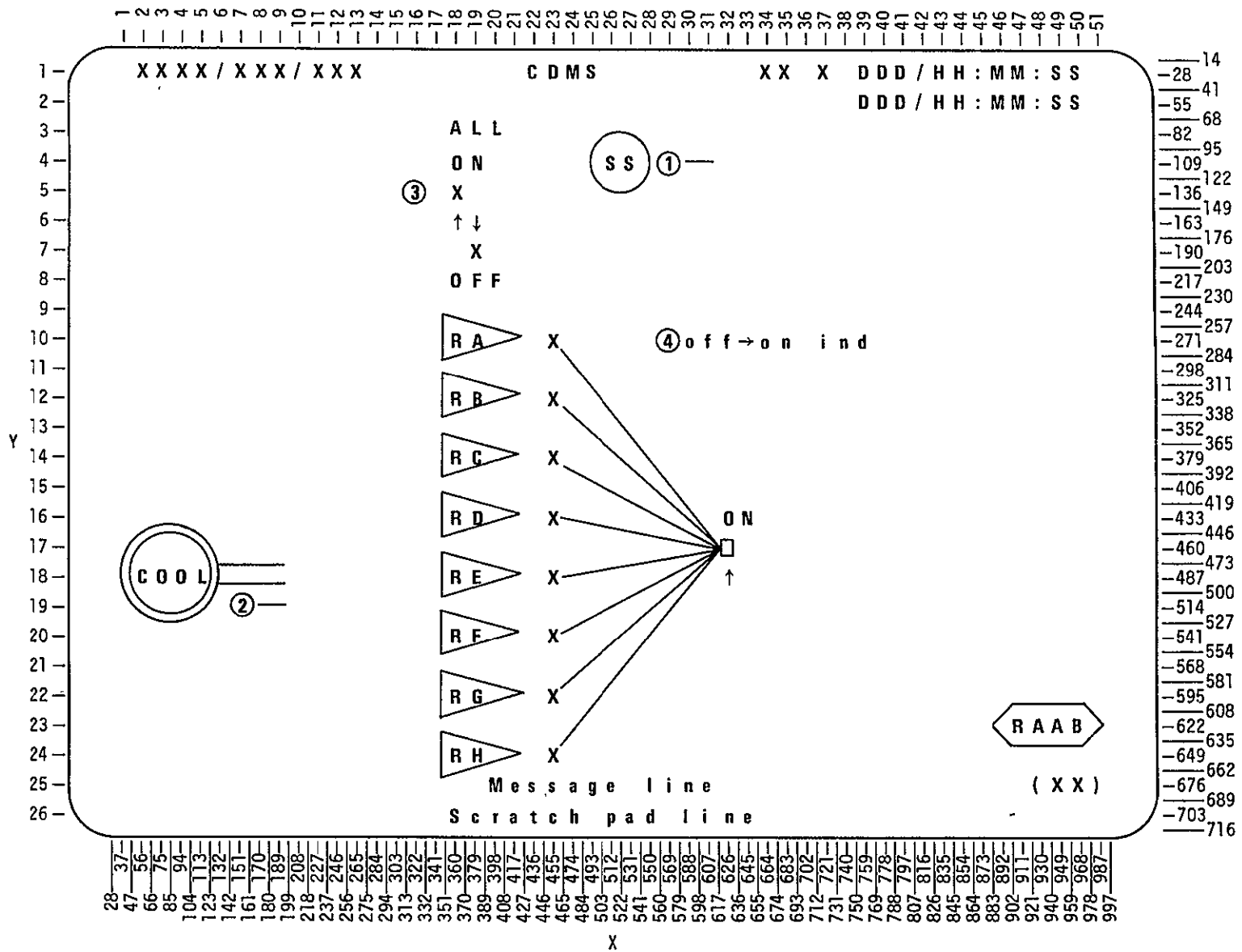

Figure 41.- SS RAU's activation display.

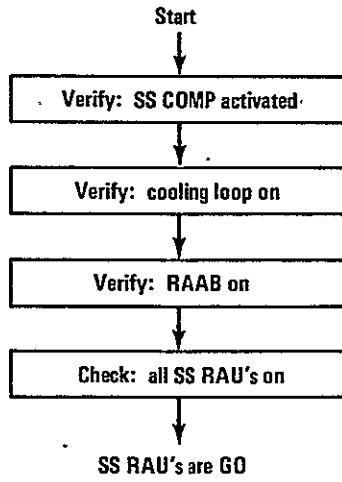

Figure 42.- SS RAU's monitoring and controlling flow chart.

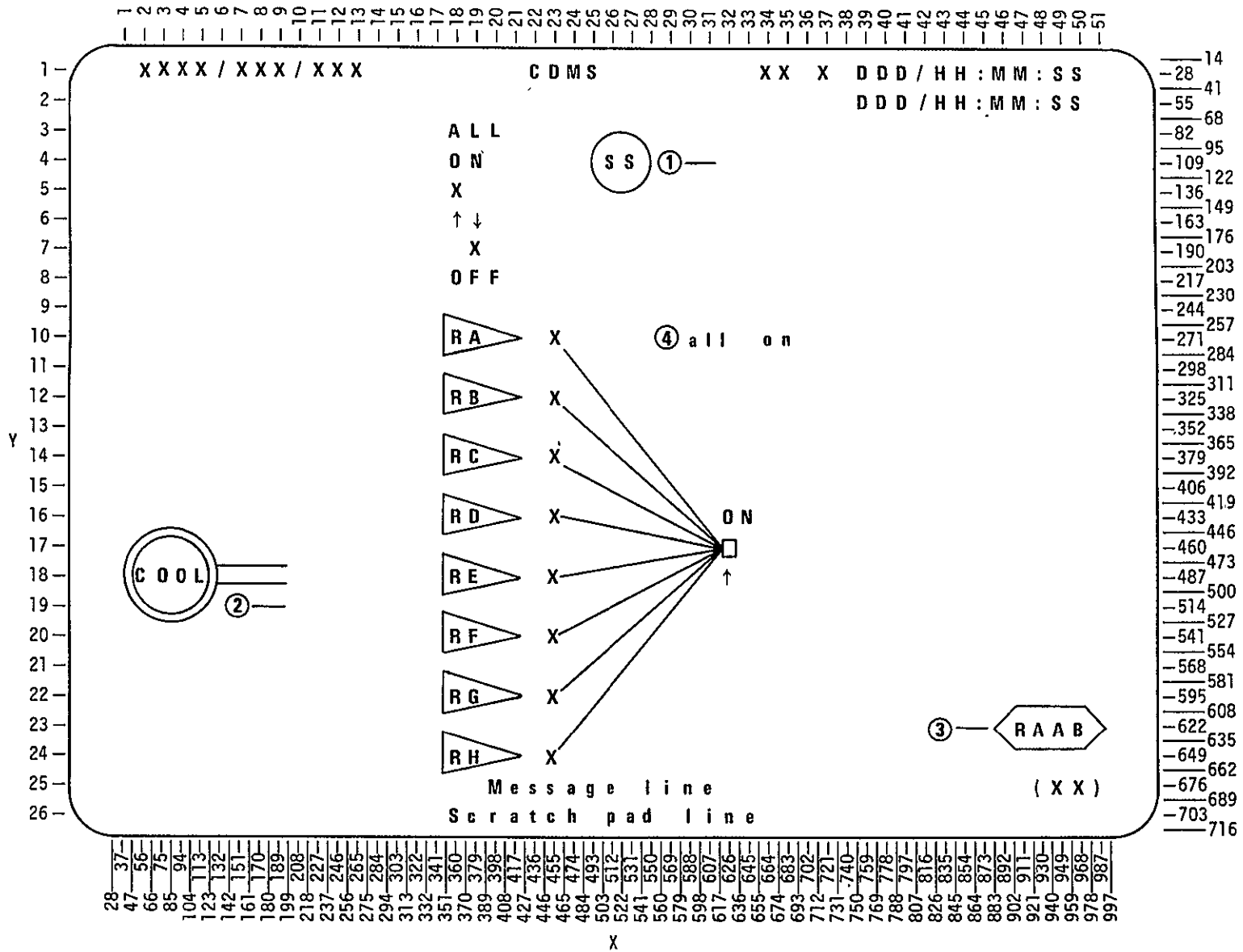

Figure 43.- SS RAU's monitoring and controlling display.

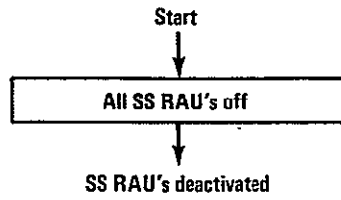

Figure 44.- SS RAU's deactivation flow chart.

ORIGINAL PAGE IS
OF POOR QUALITY

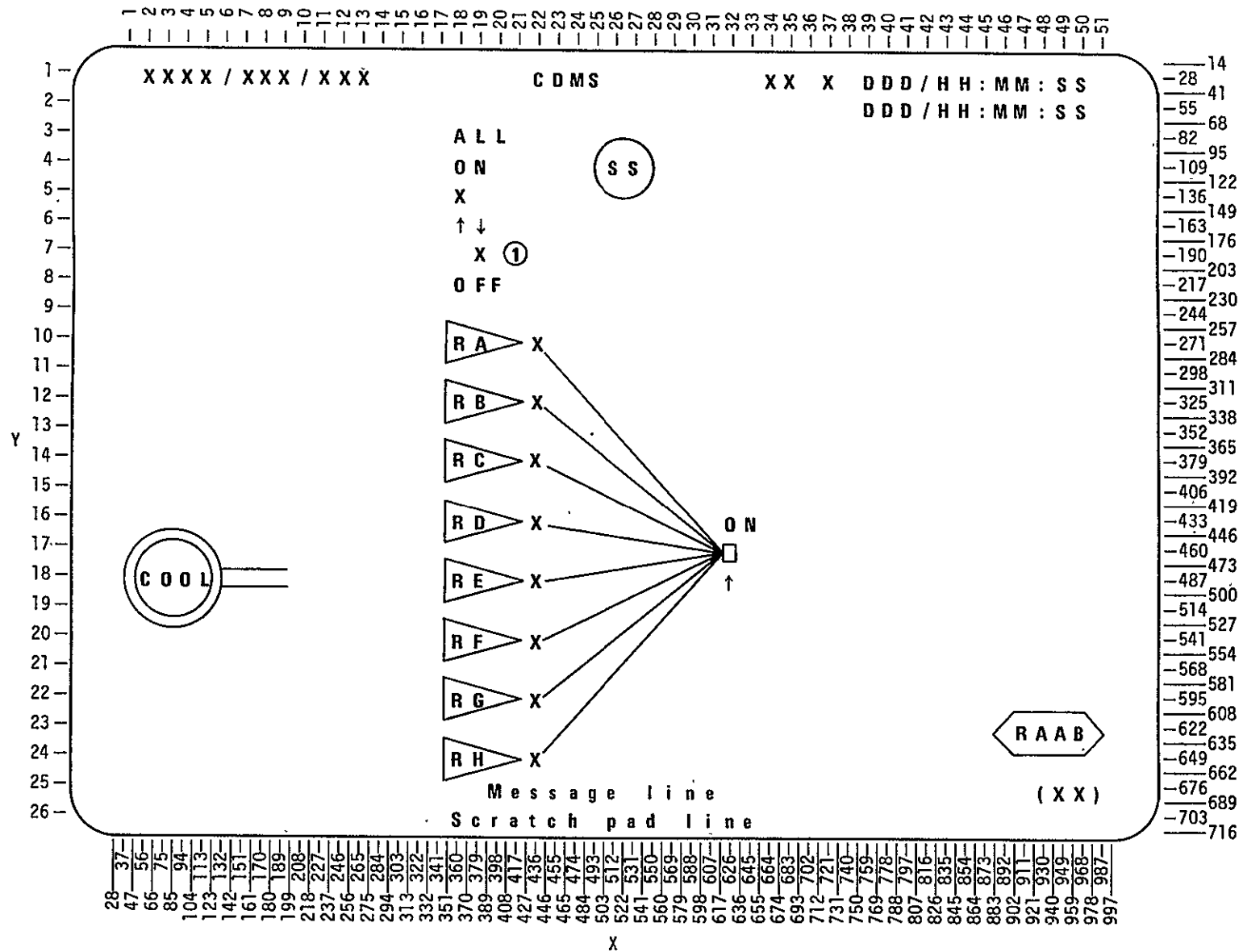

Figure 45.- SS RAU's deactivation display.

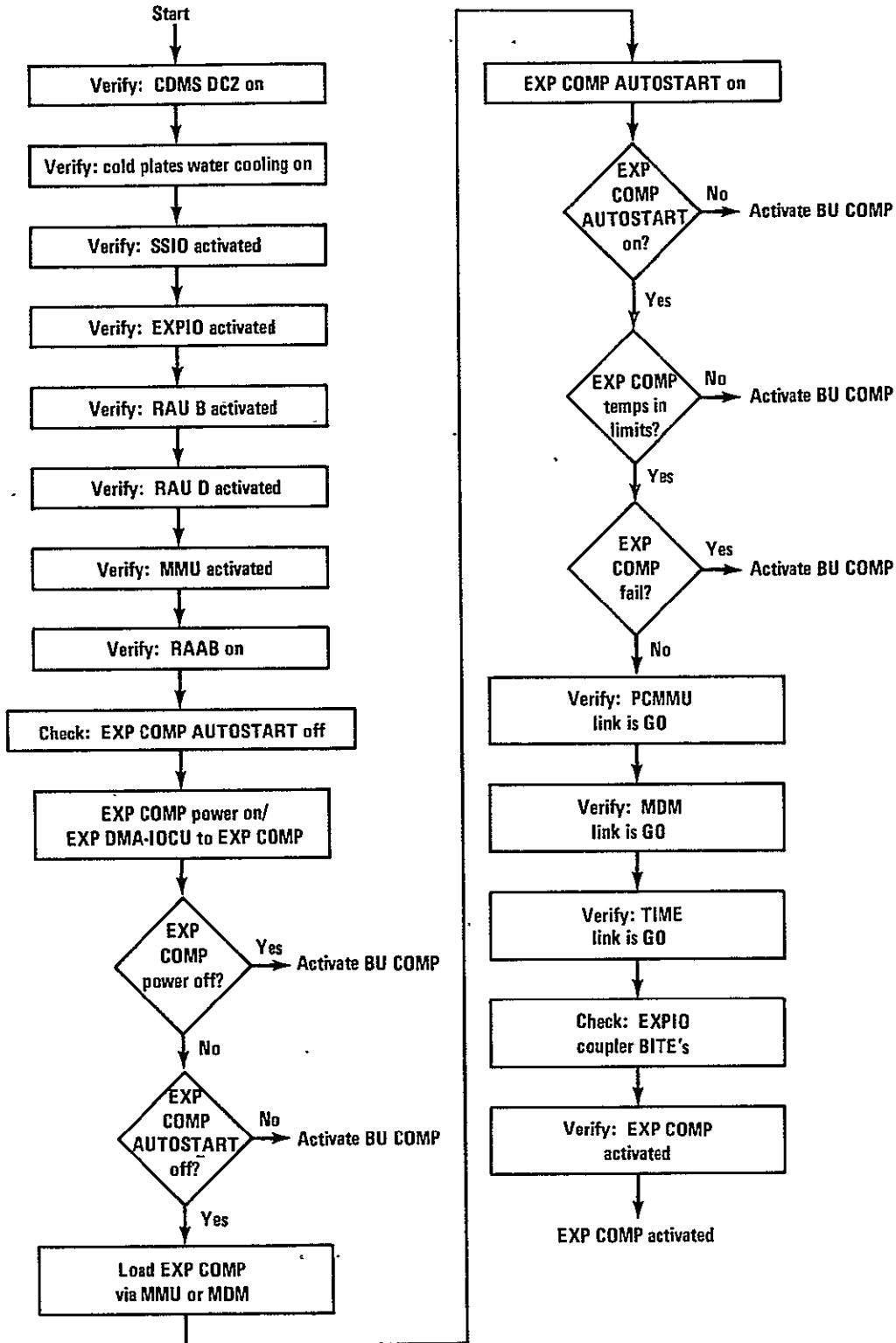
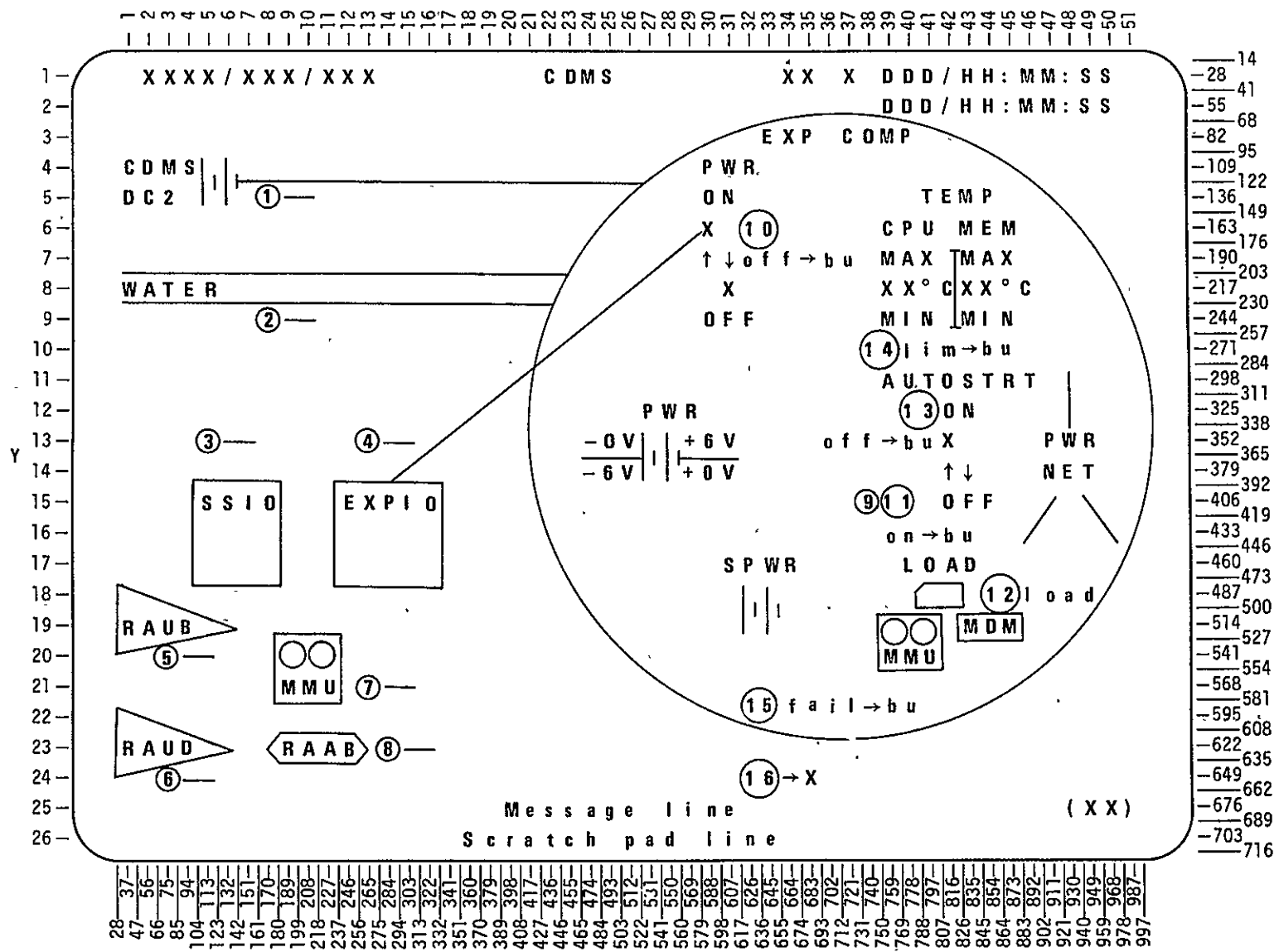
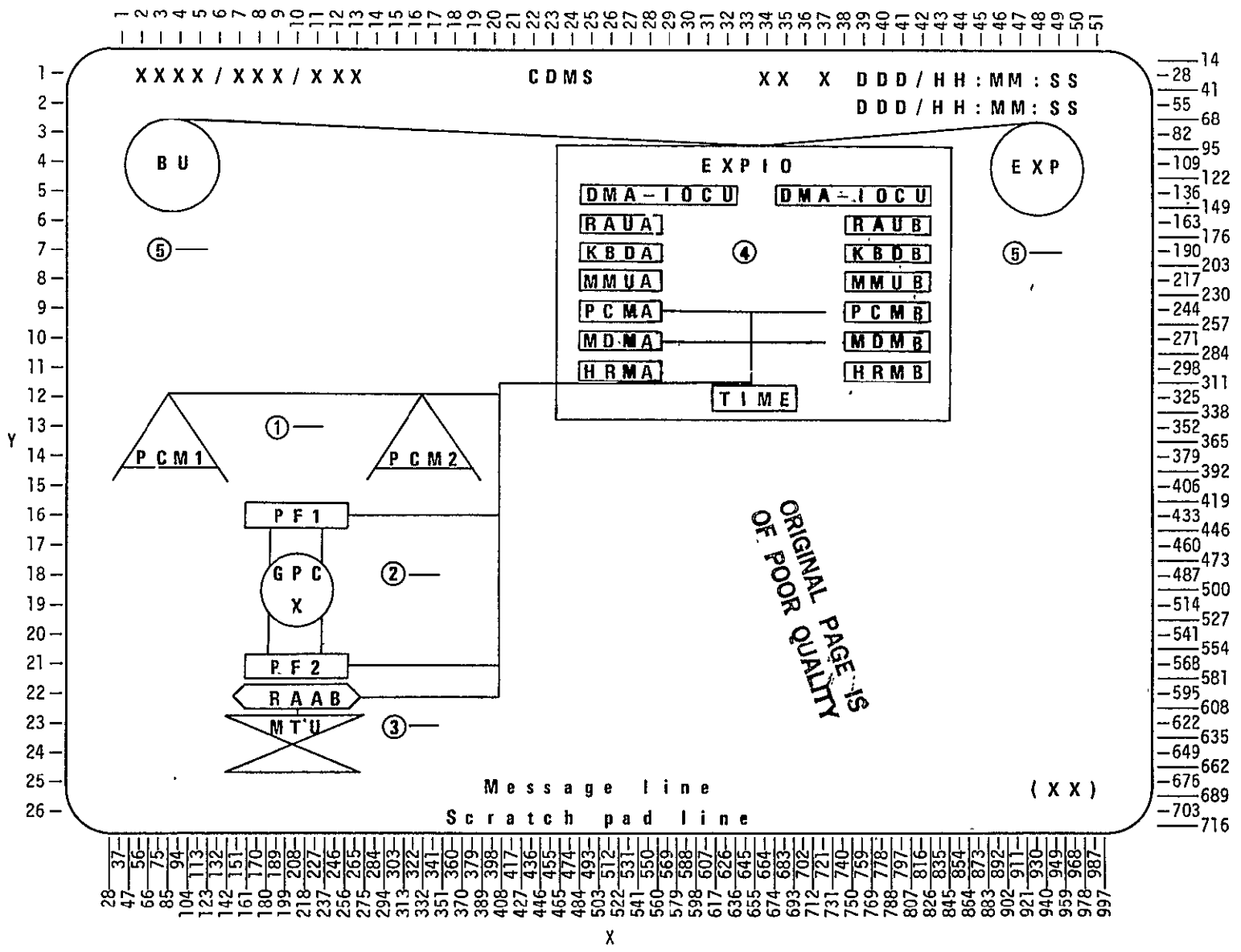

Figure 46.- EXP COMP activation flow chart.



(a) Initial display.

Figure 47.- EXP COMP activation displays.



(b) Concluding display.

Figure 47.- Concluded.

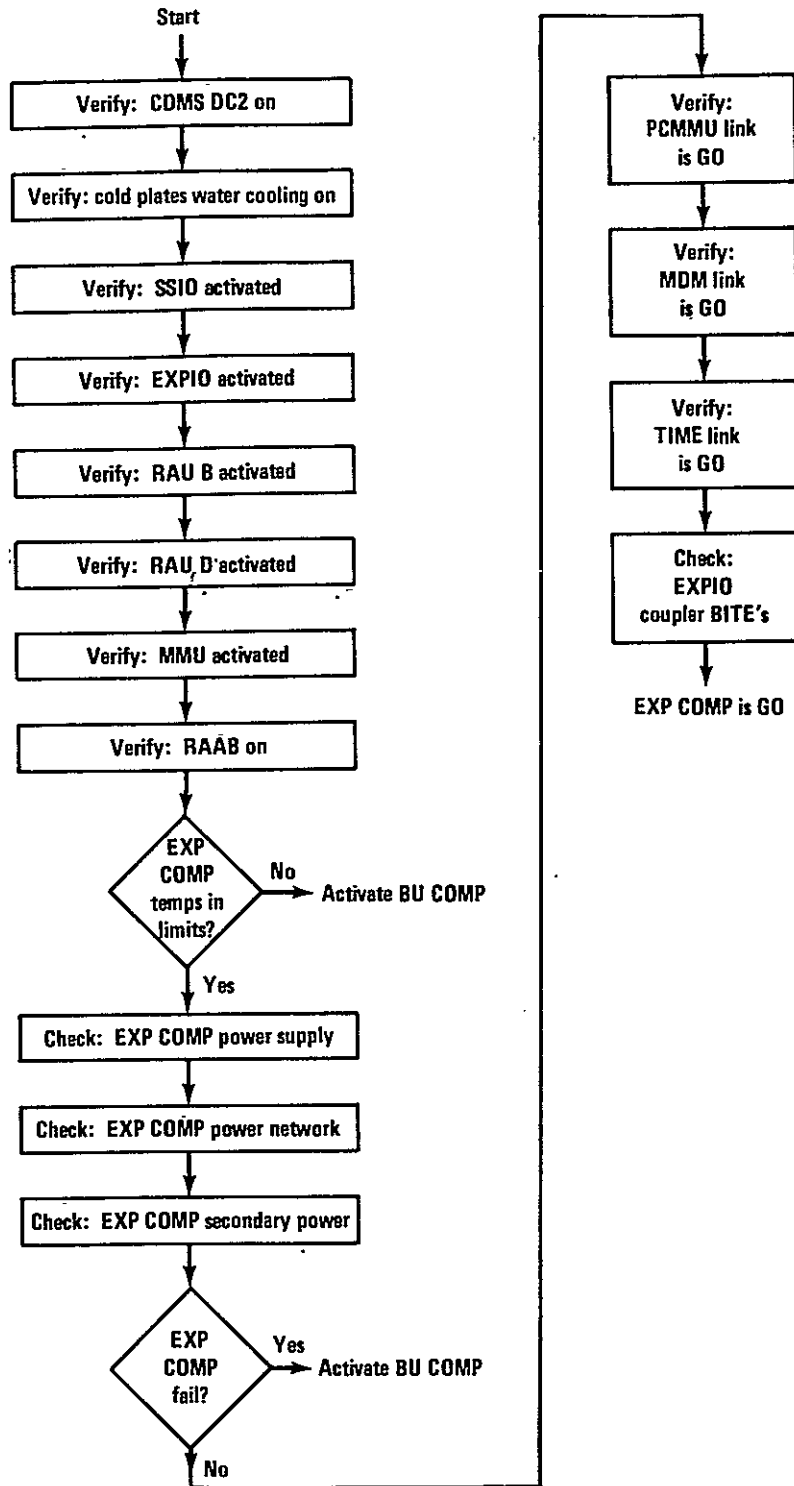
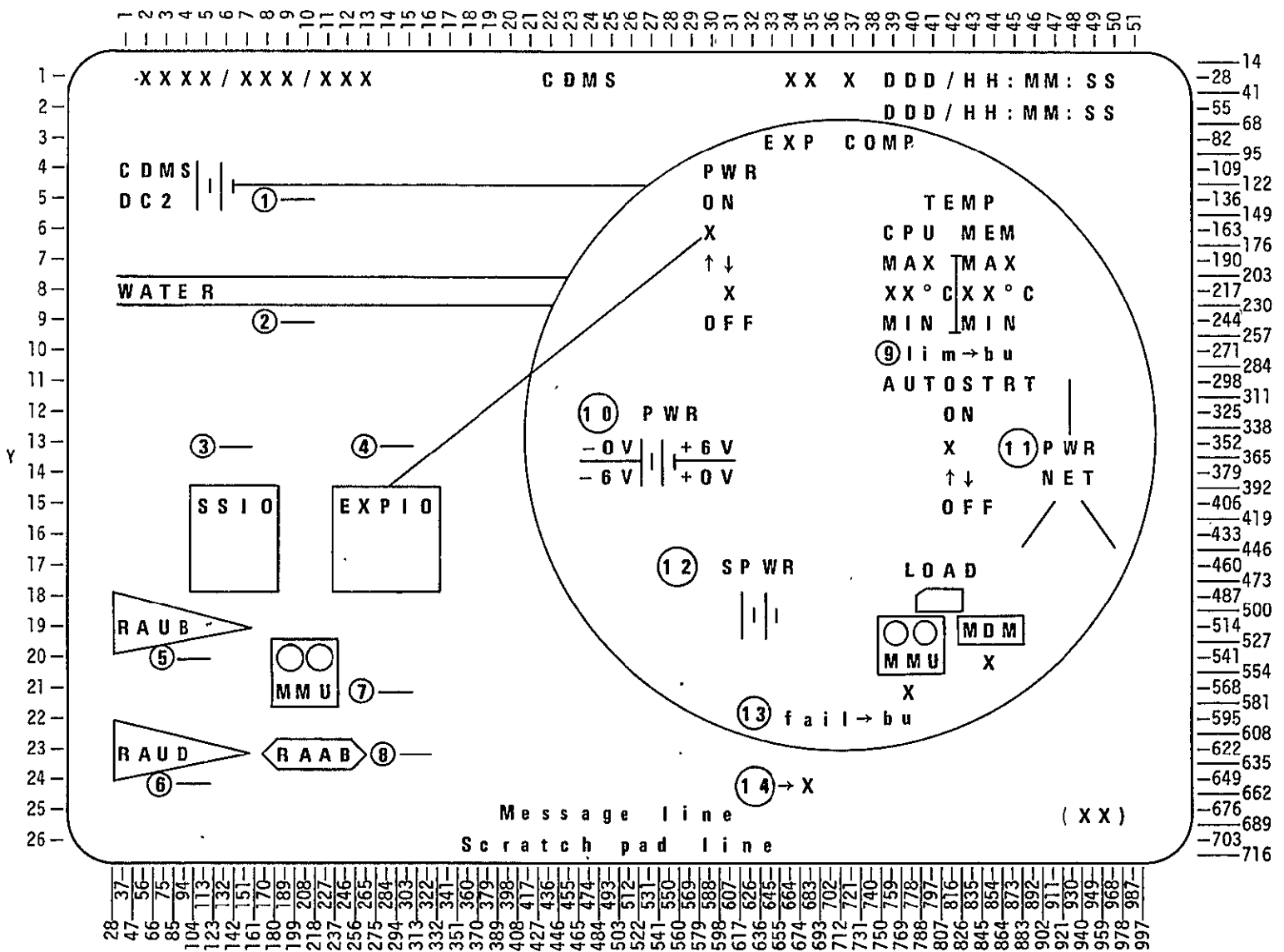

Figure 48.- EXP COMP monitoring and controlling flow chart.



(a) Initial display.

Figure 49.- EXP COMP monitoring and controlling displays.

ORIGINAL PAGE IS OF POOR QUALITY

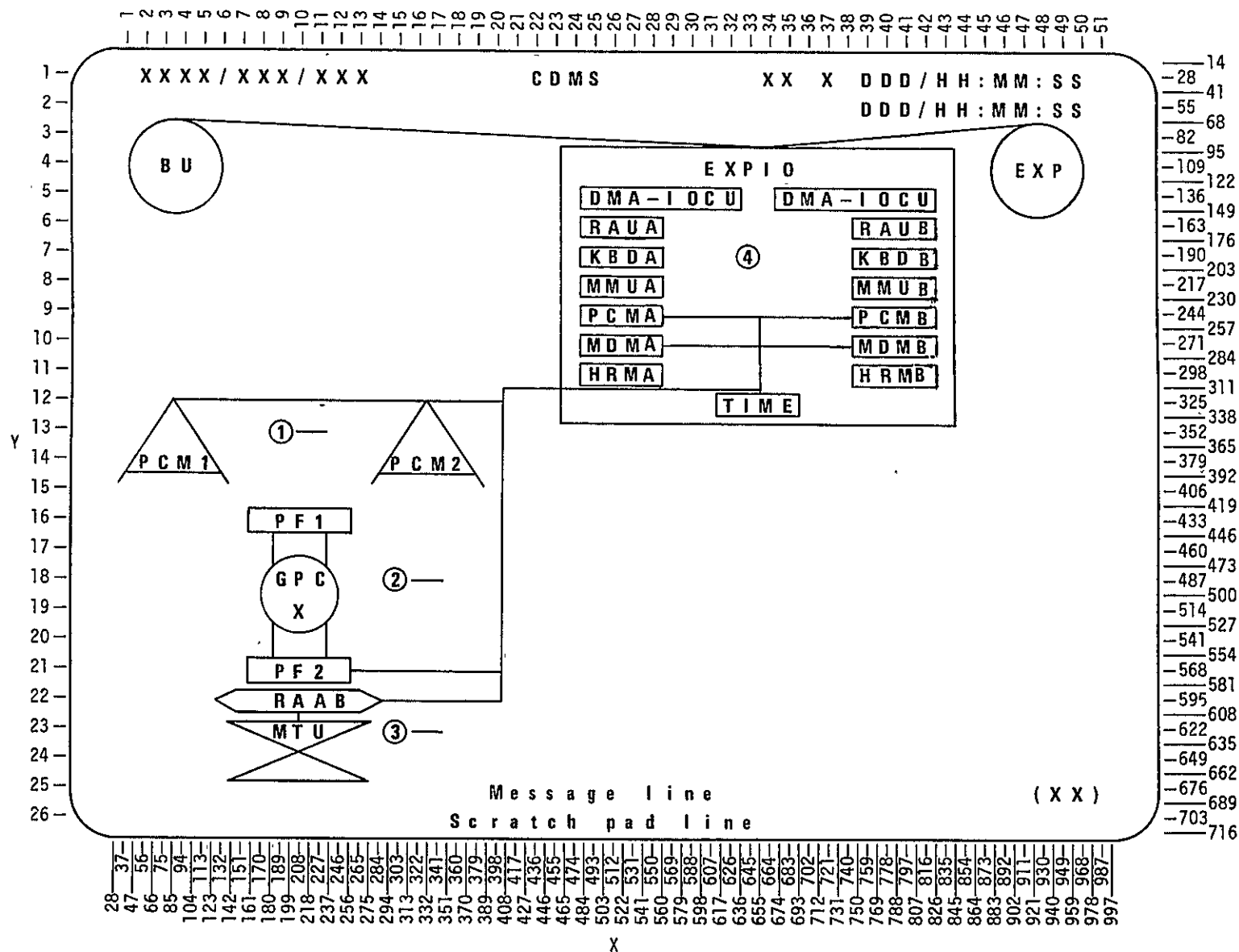

(b) Concluding display.

Figure 49.- Concluded.

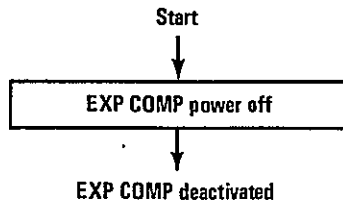
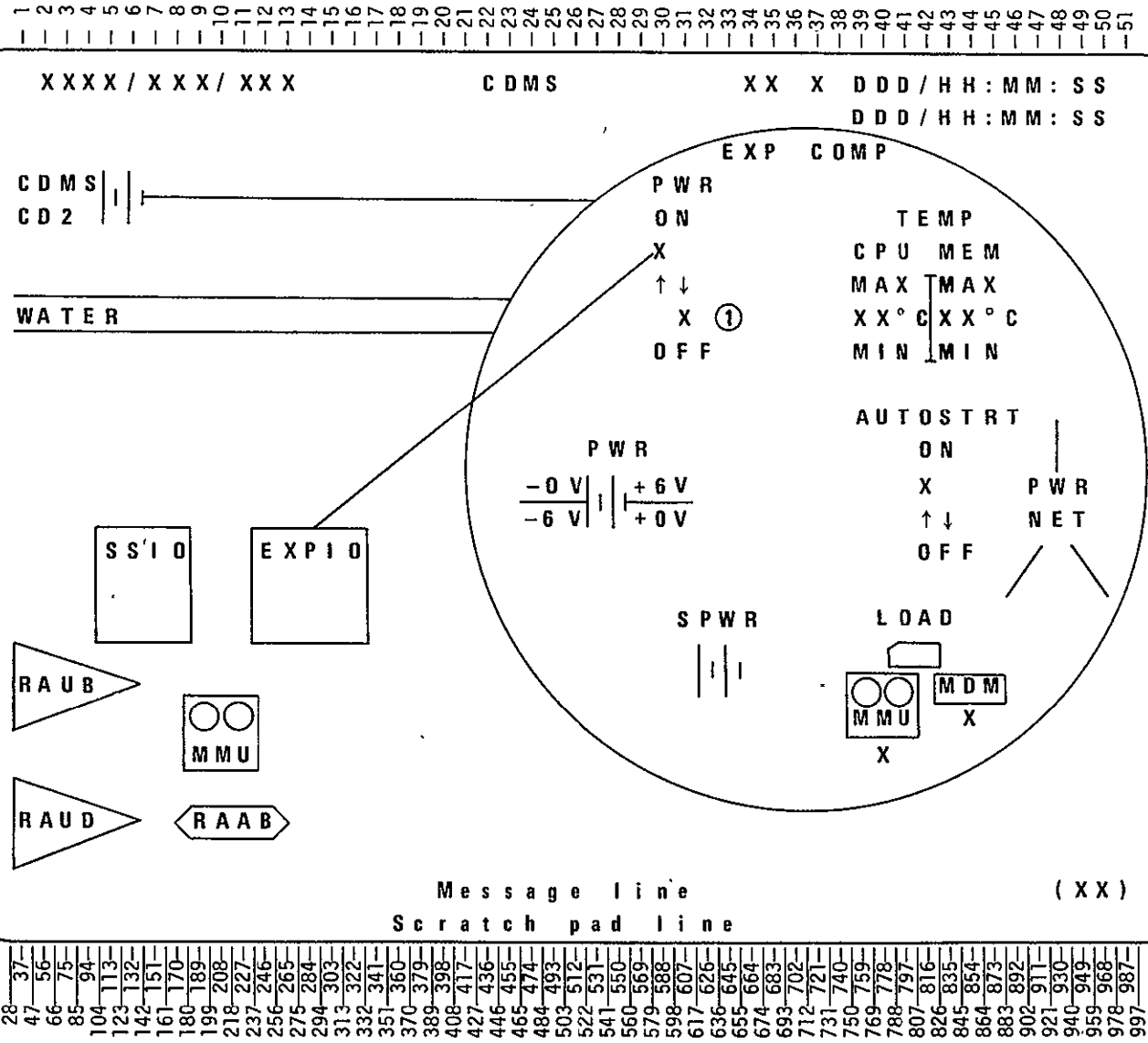

Figure 50.- EXP COMP deactivation flow chart.



250

ORIGINAL PAGE IS
OF POOR QUALITY.

Figure 51.- EXP COMP deactivation display.

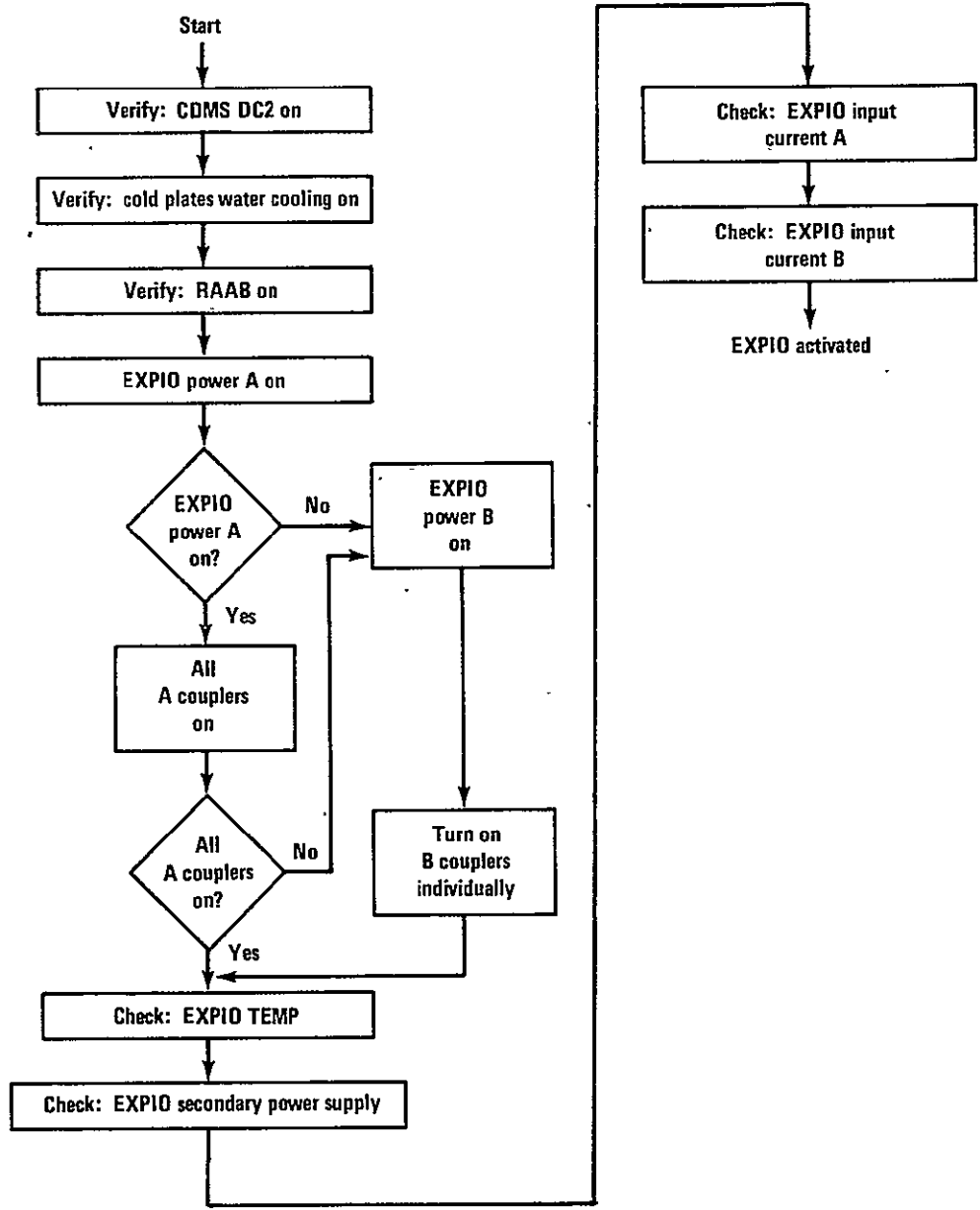

Figure 52.- EXPIO activation flow chart.

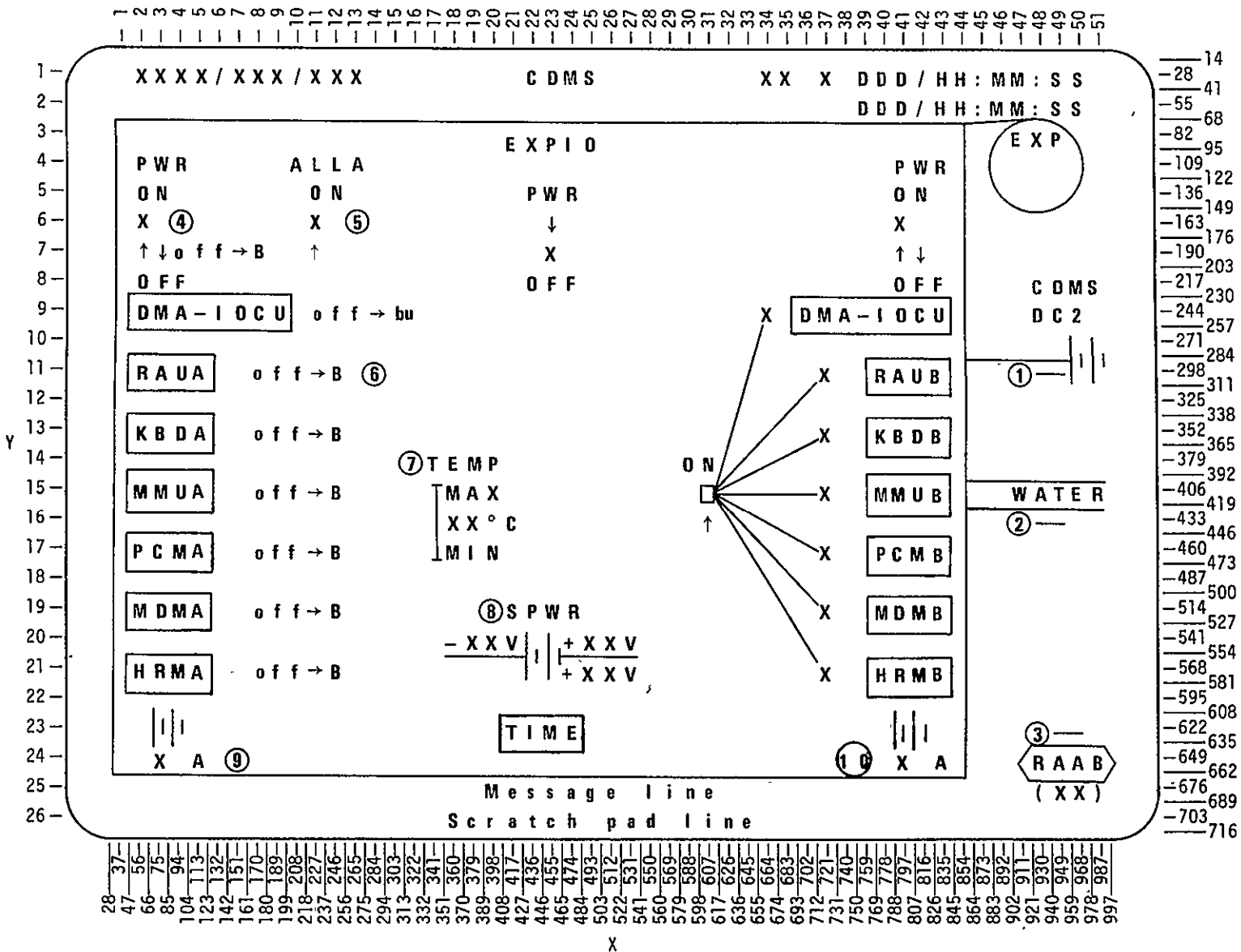
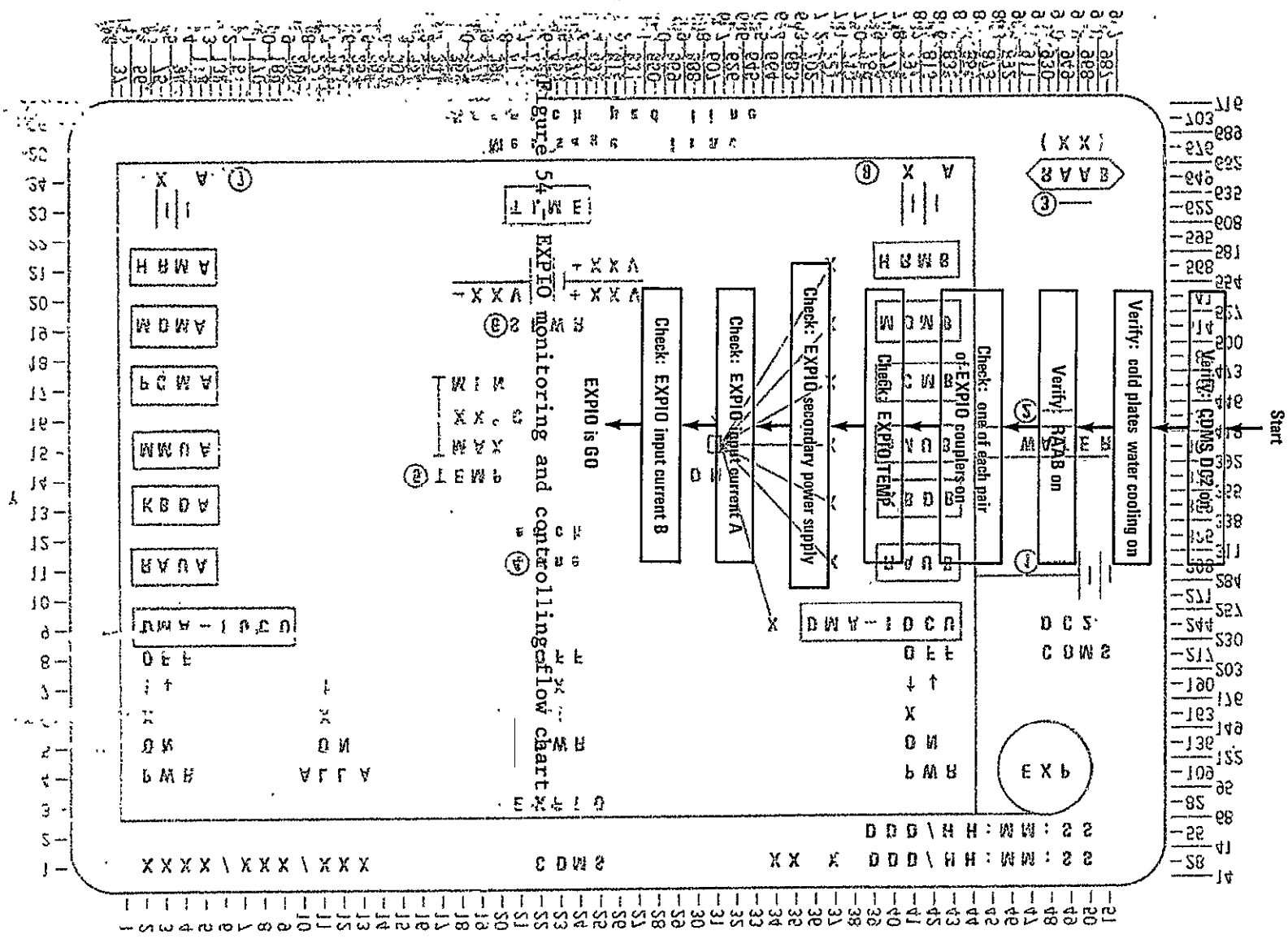

Figure 53.- EXPIO activation display.

ORIGINAL PAGE IS
OF POOR QUALITY



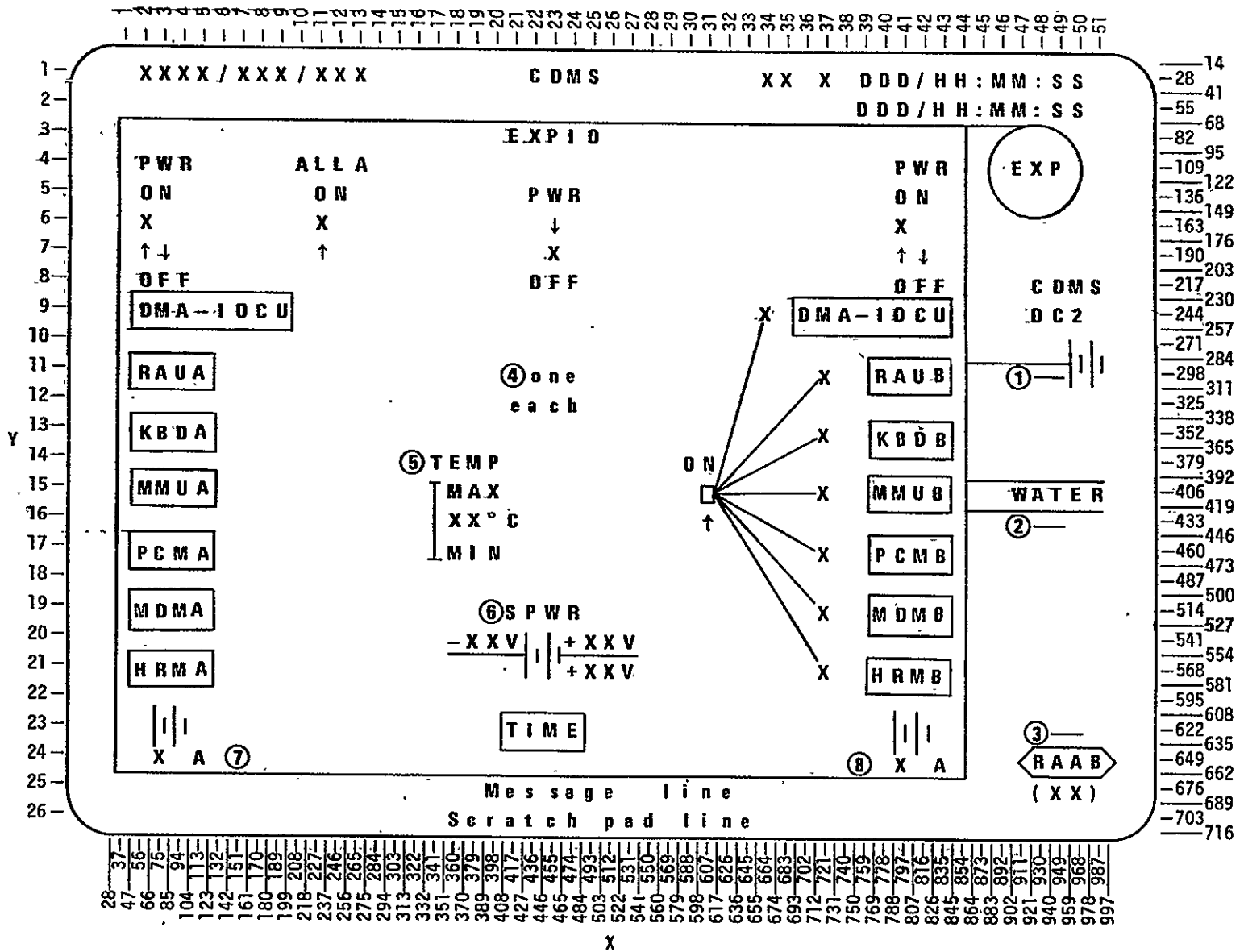

Figure 55.- EXPIO monitoring and controlling display.

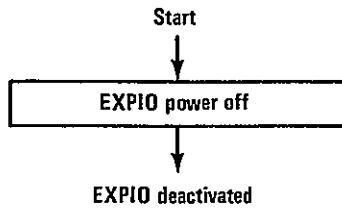

Figure 56.- EXPIO deactivation flow chart.

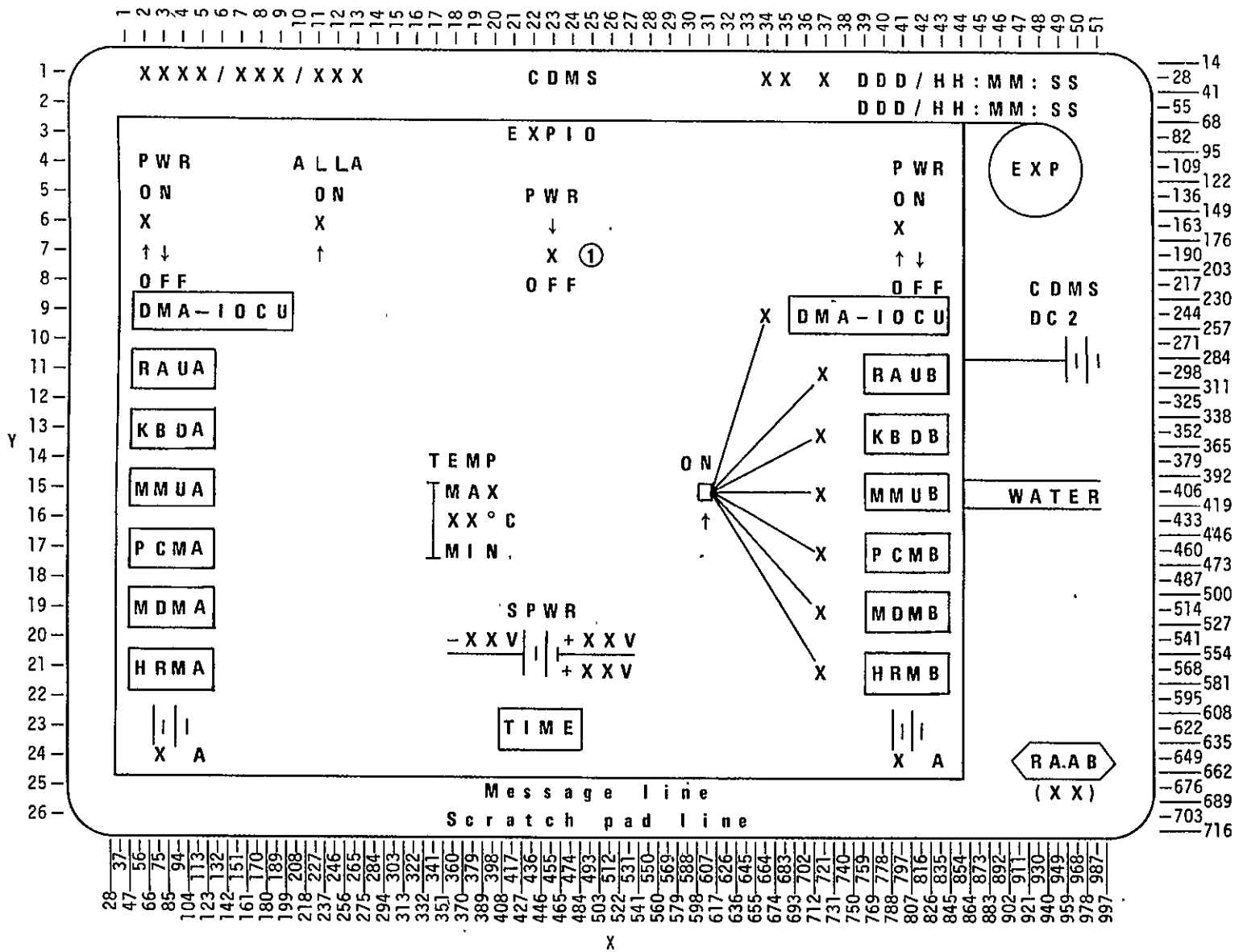

Figure 57.- EXPIO deactivation display.

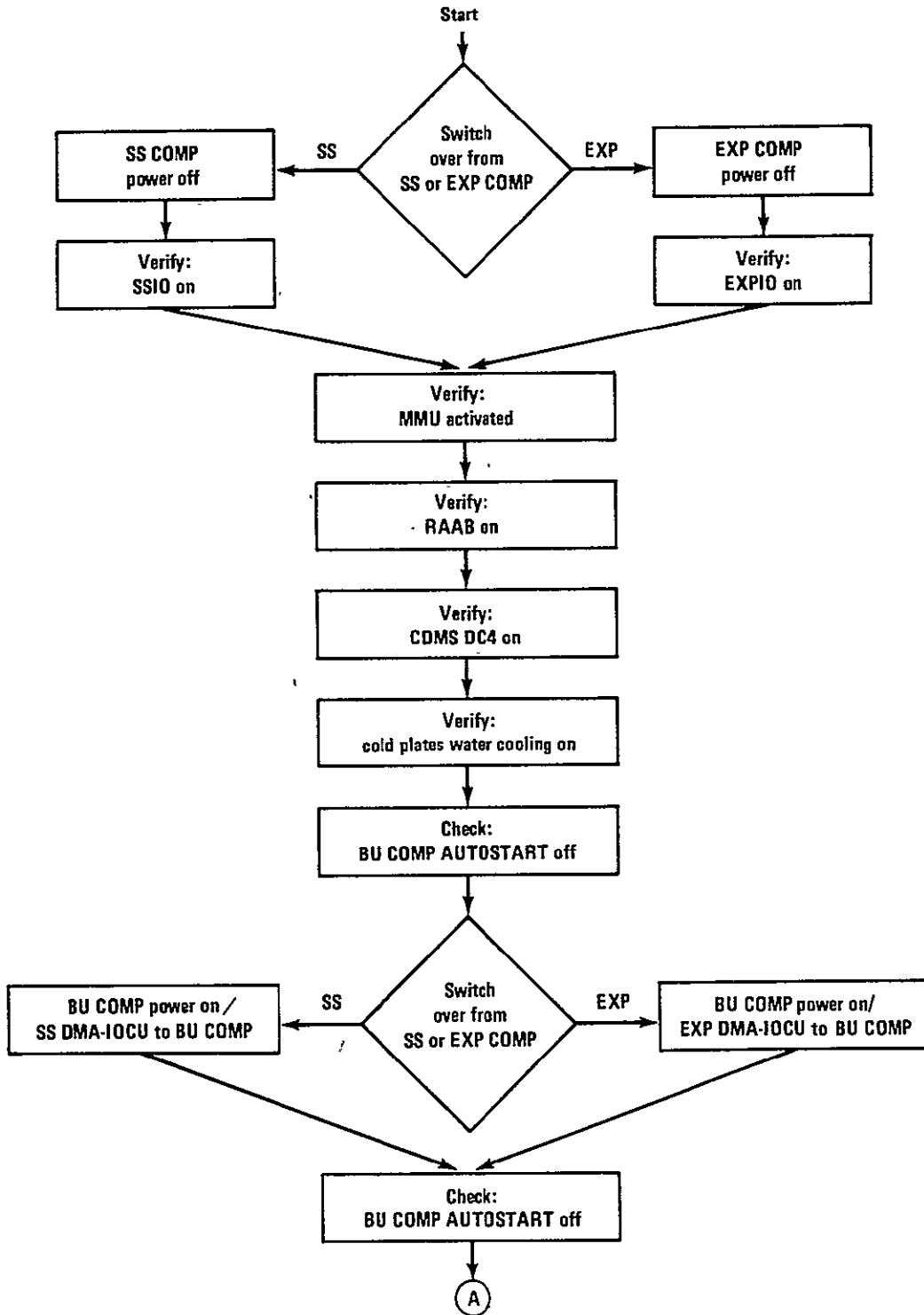

Figure 58.- BU COMP activation flow chart.

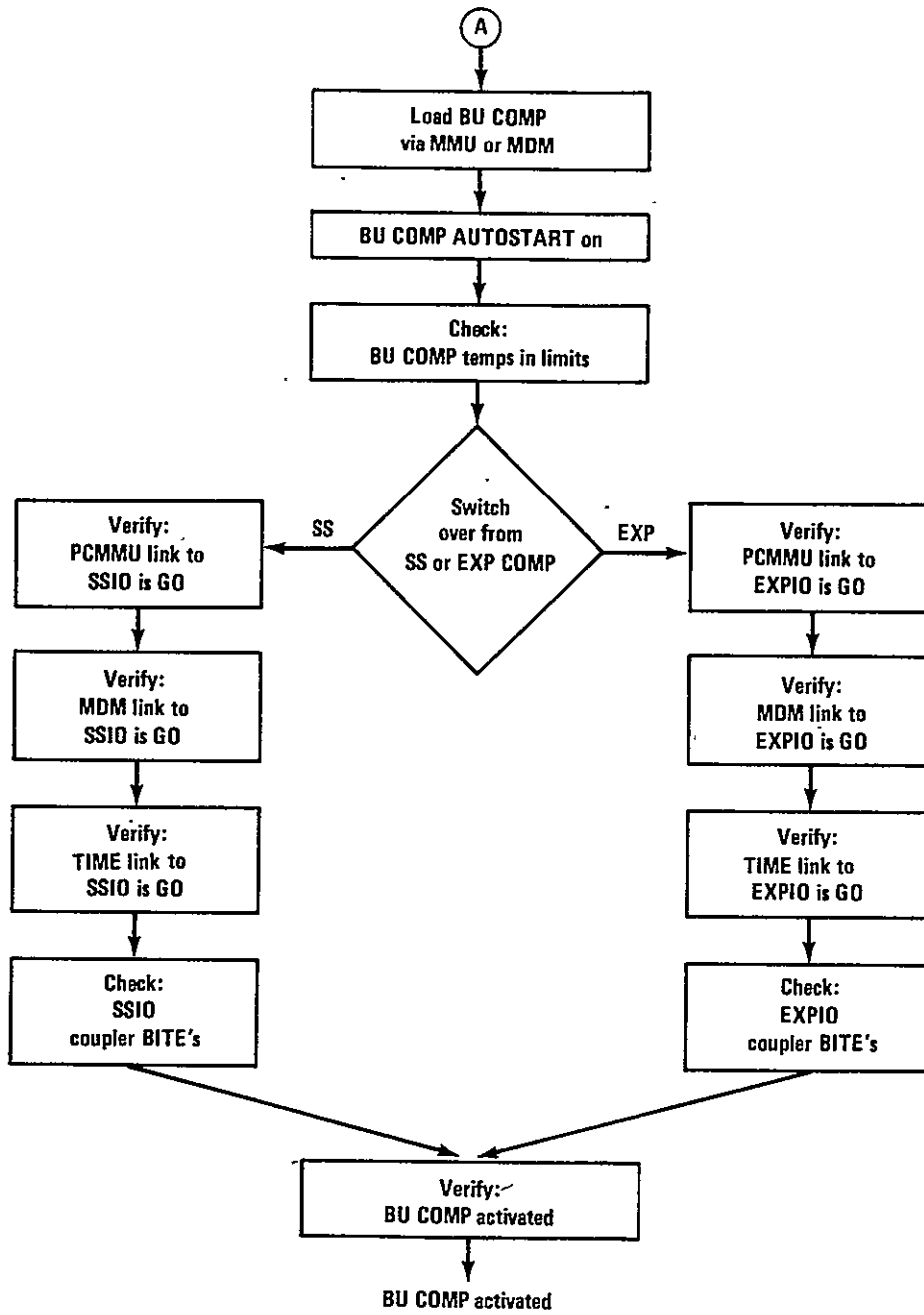
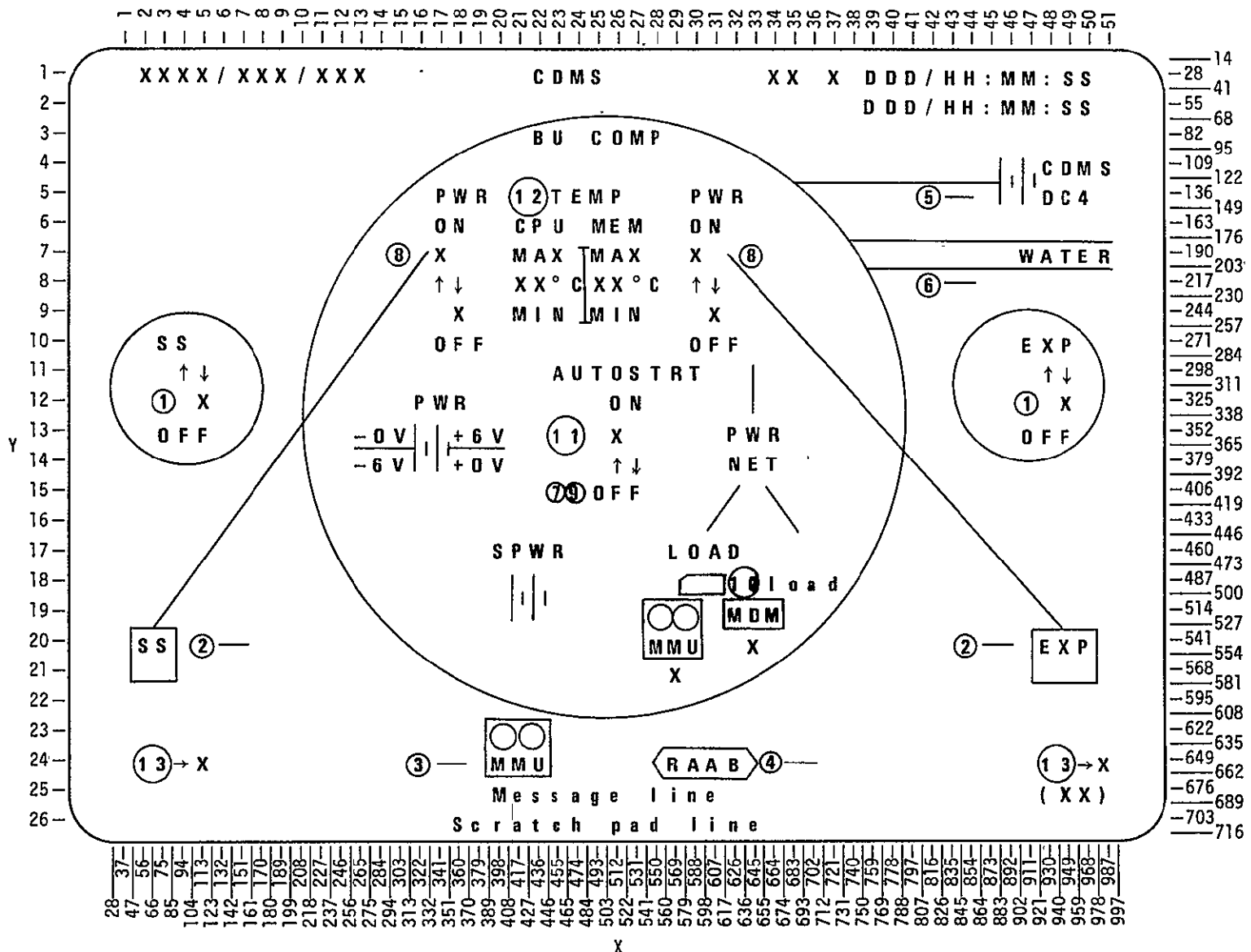
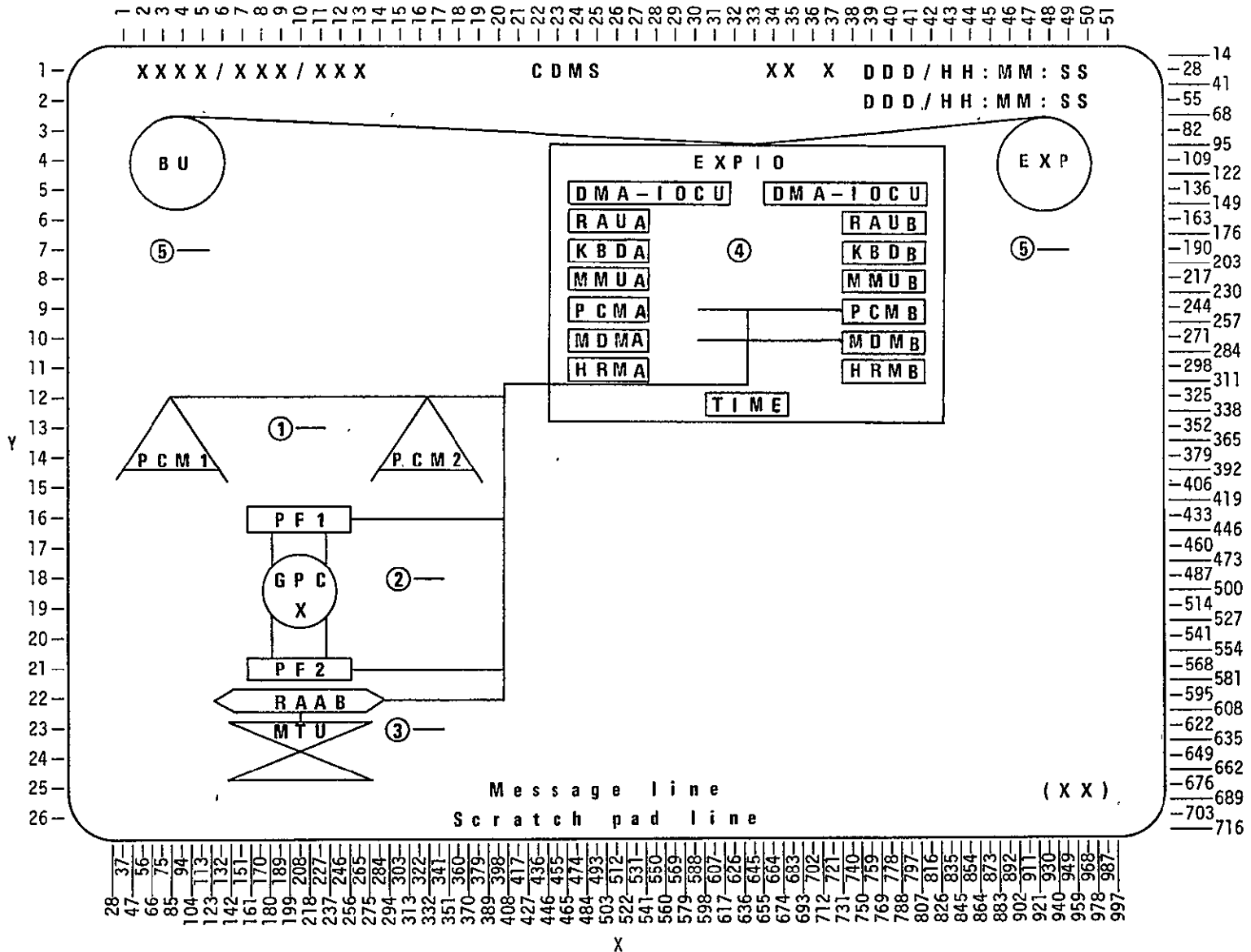

Figure 58.- Concluded.



(a) Initial display.

Figure 59.- BU COMP activation displays.



(c) Switchover from EXP COMP.

Figure 59.- Concluded.

PRECEDING PAGE BLANK NOT FILLED

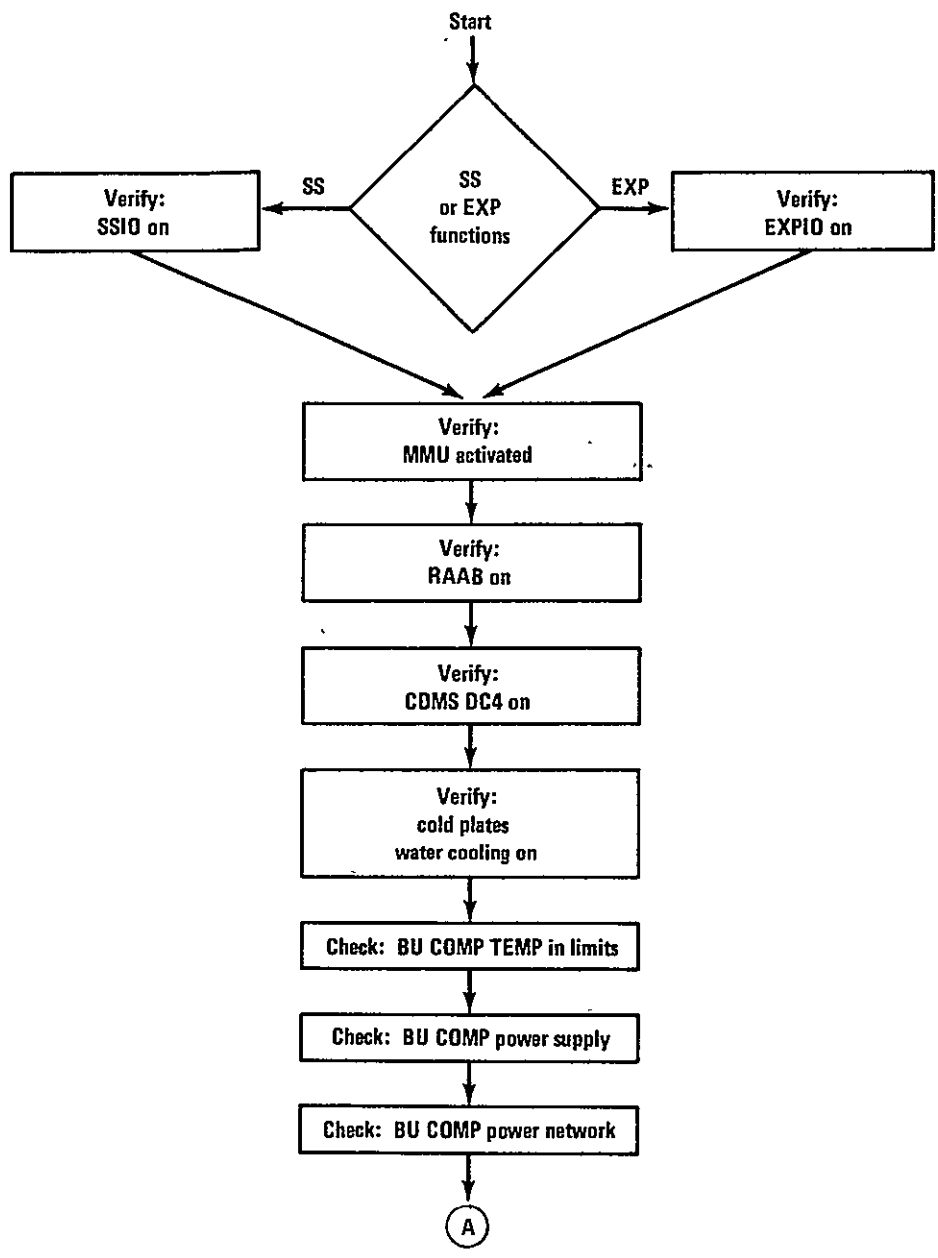

Figure 60.- BU COMP monitoring and controlling flow chart.

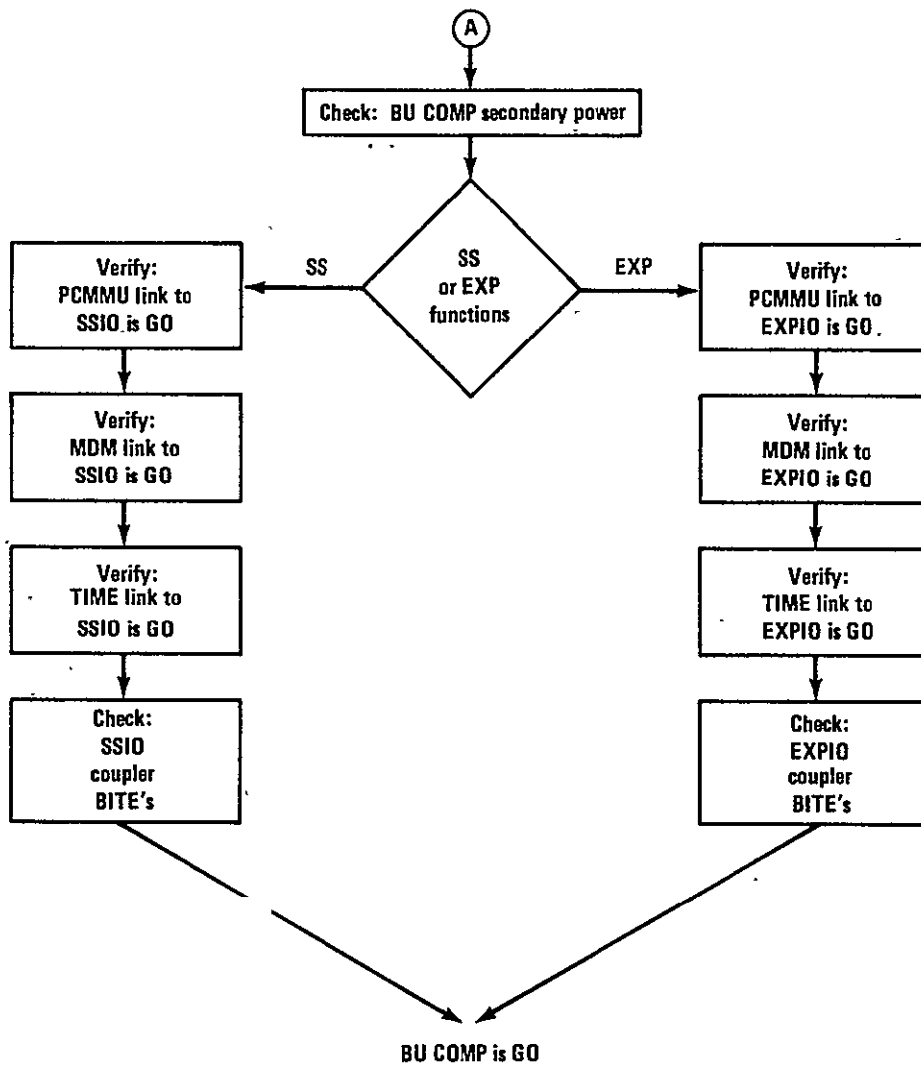
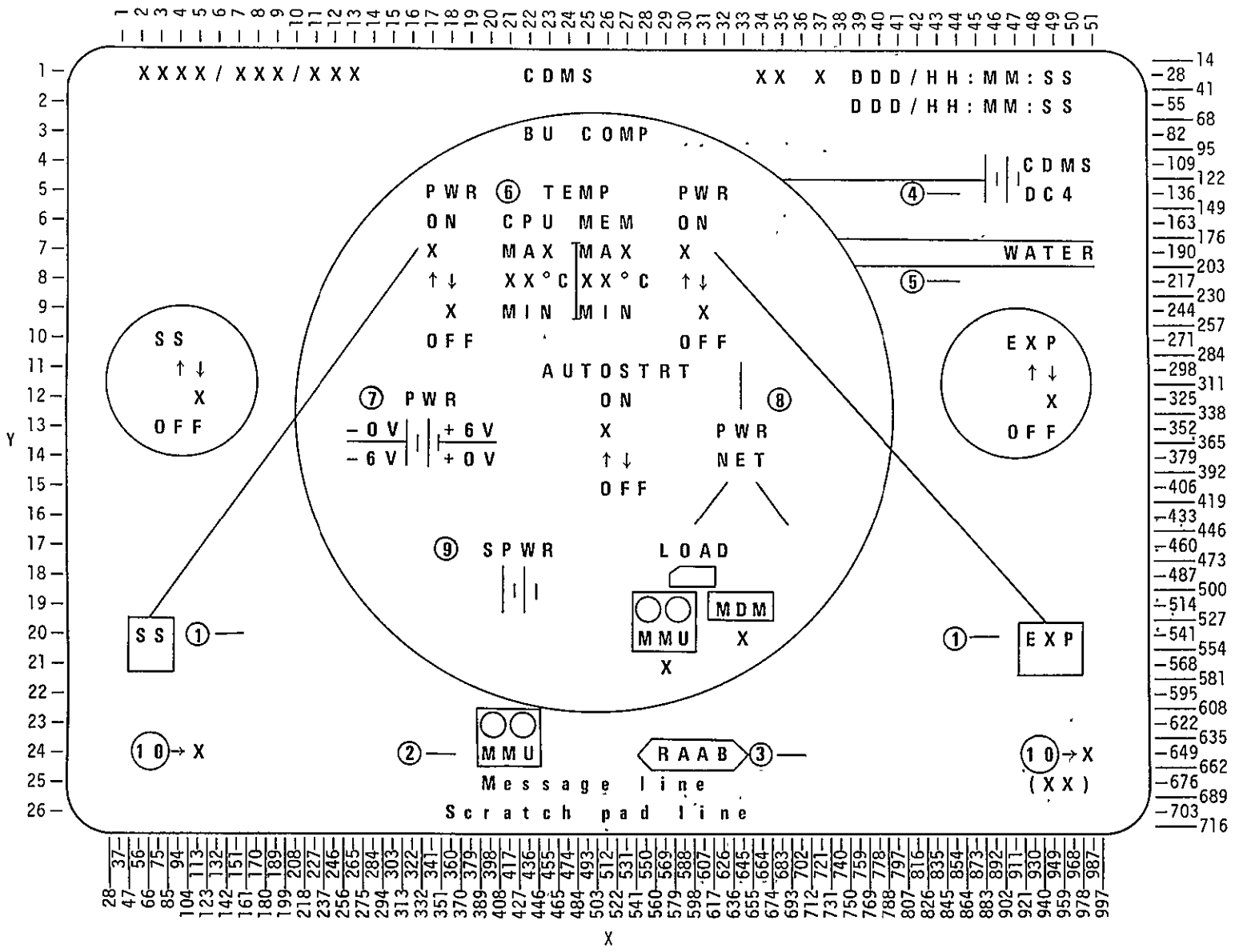

Figure 60.- Concluded.

ORIGINAL PAGE IS
OF POOR QUALITY

264



(a) Initial display.

Figure 61.- BU COMP monitoring and controlling display.

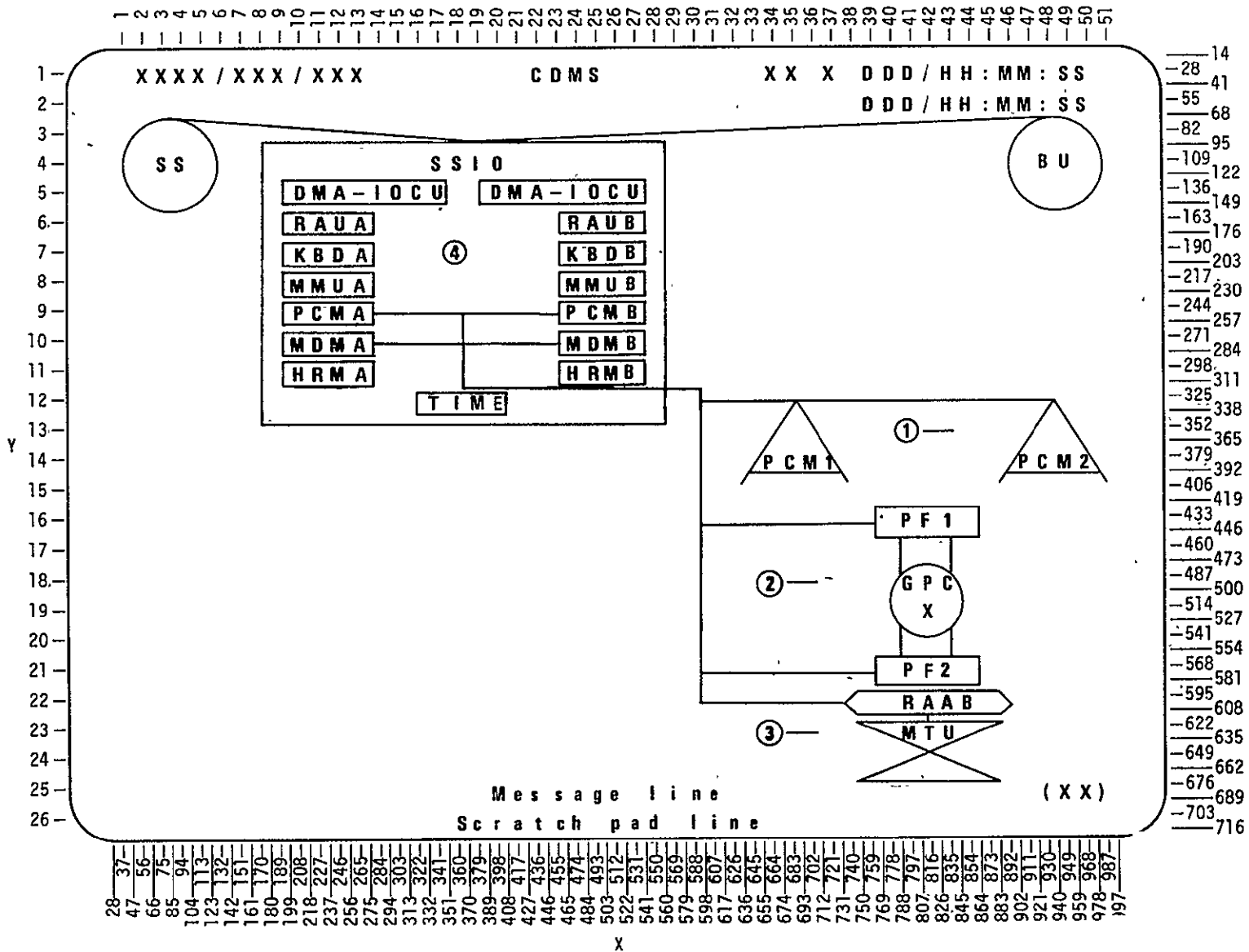

(b) BU COMP performing SS functions.

Figure 61.- Continued.

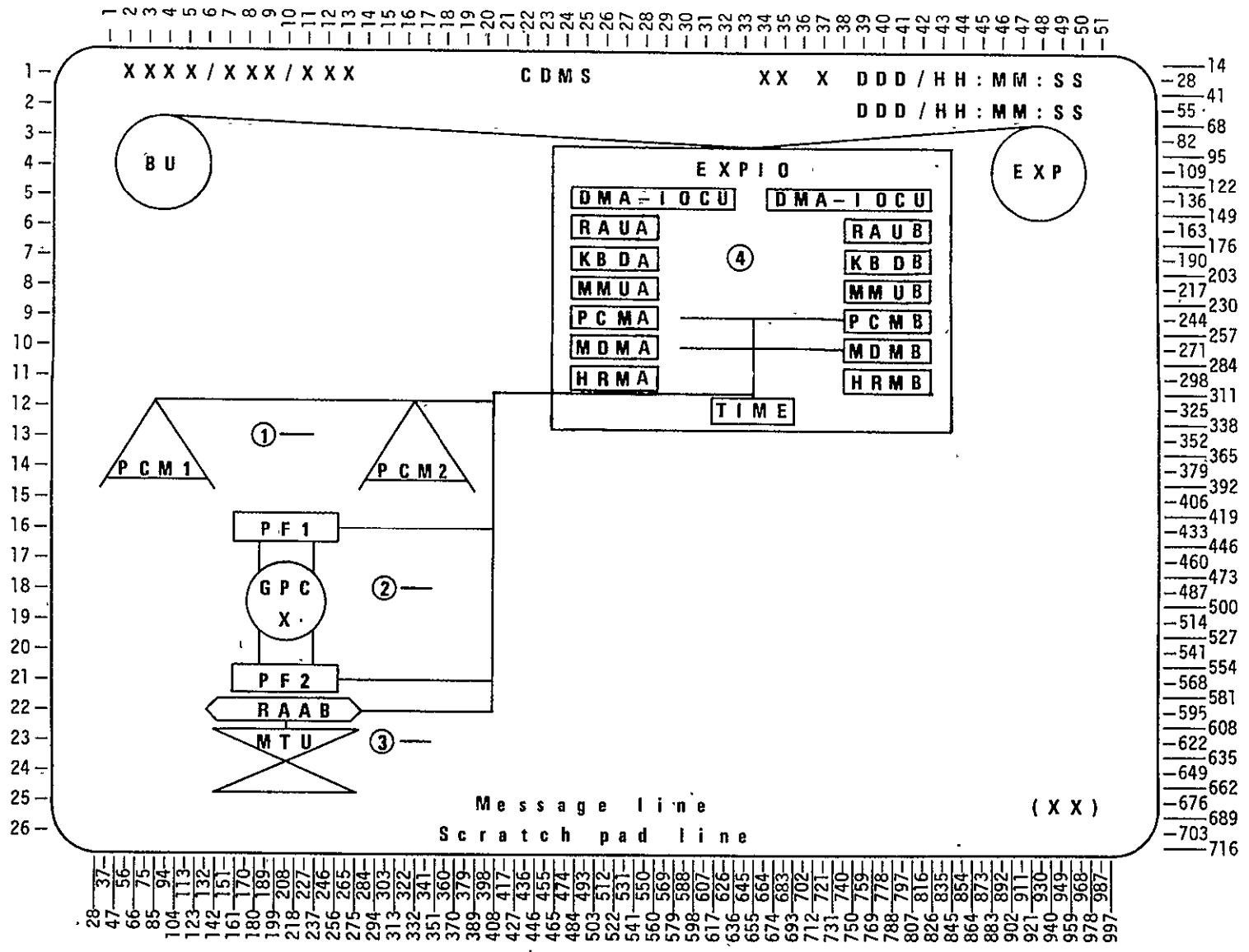

(c) BU COMP performing EXP functions.

Figure 61.- Concluded.

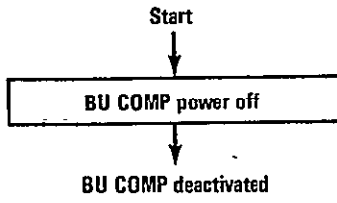

Figure 62.- BU COMP deactivation flow chart.

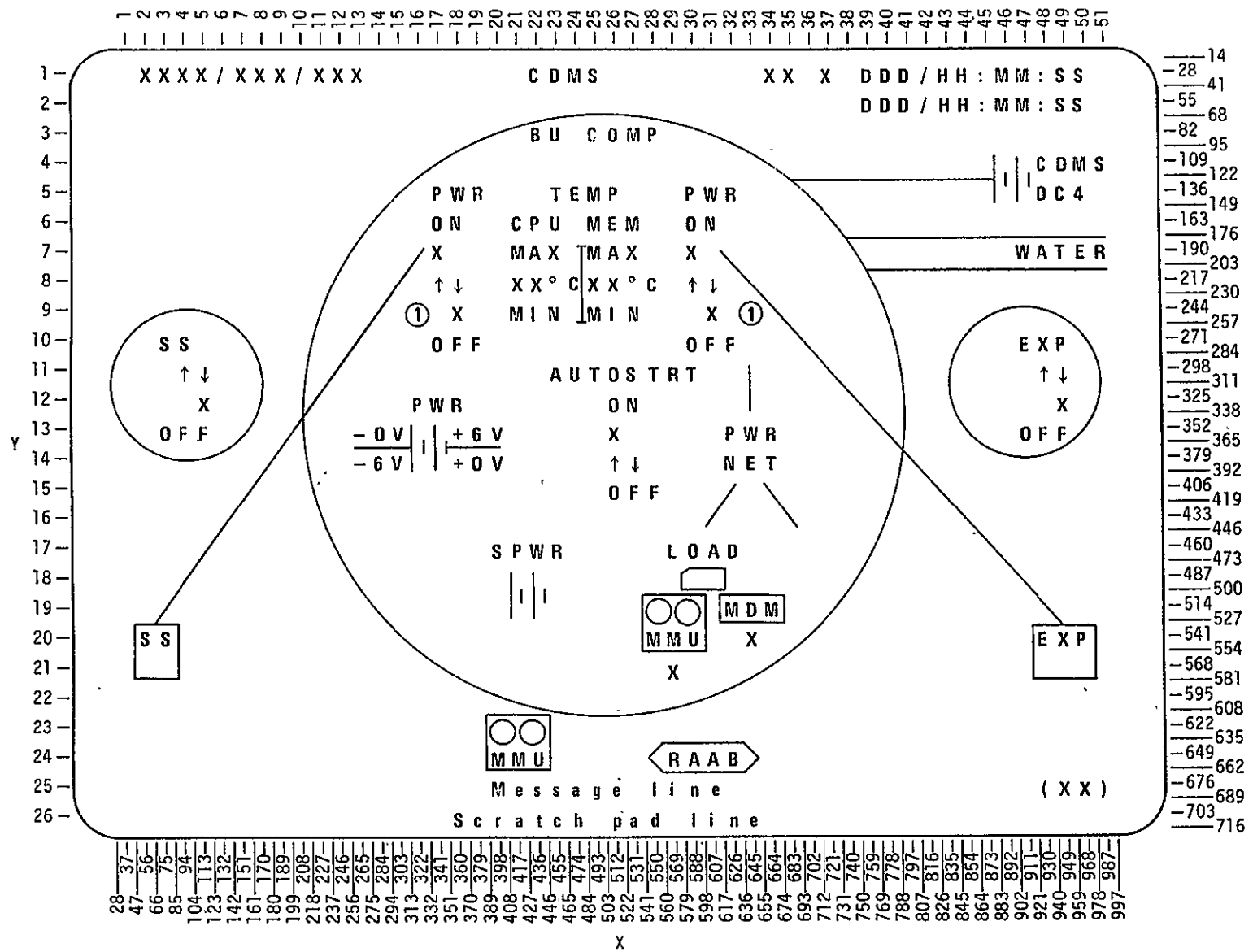

Figure 63.- BU COMP deactivation display.

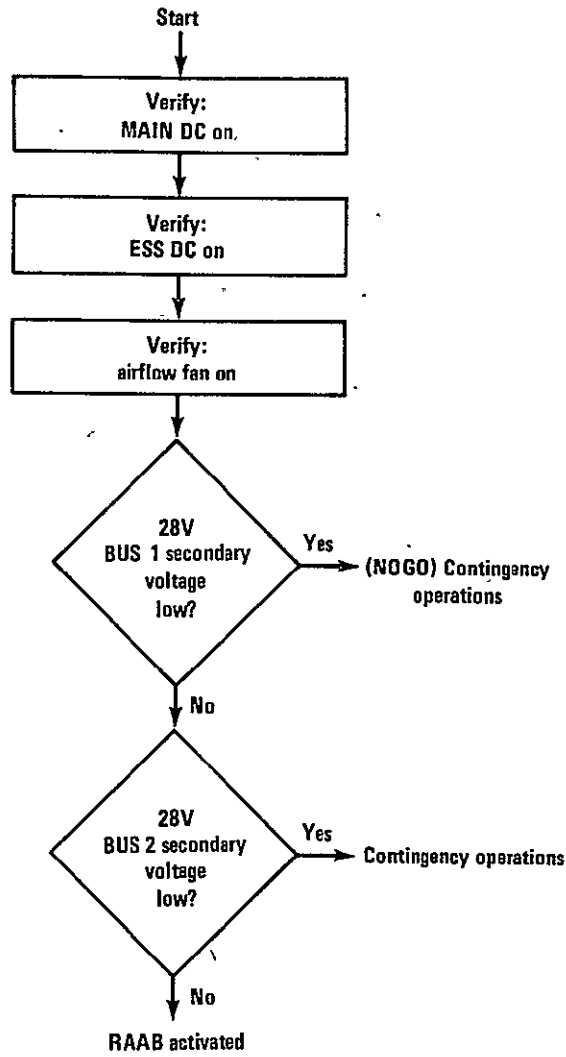

Figure 64.- RAAB activation flow chart.

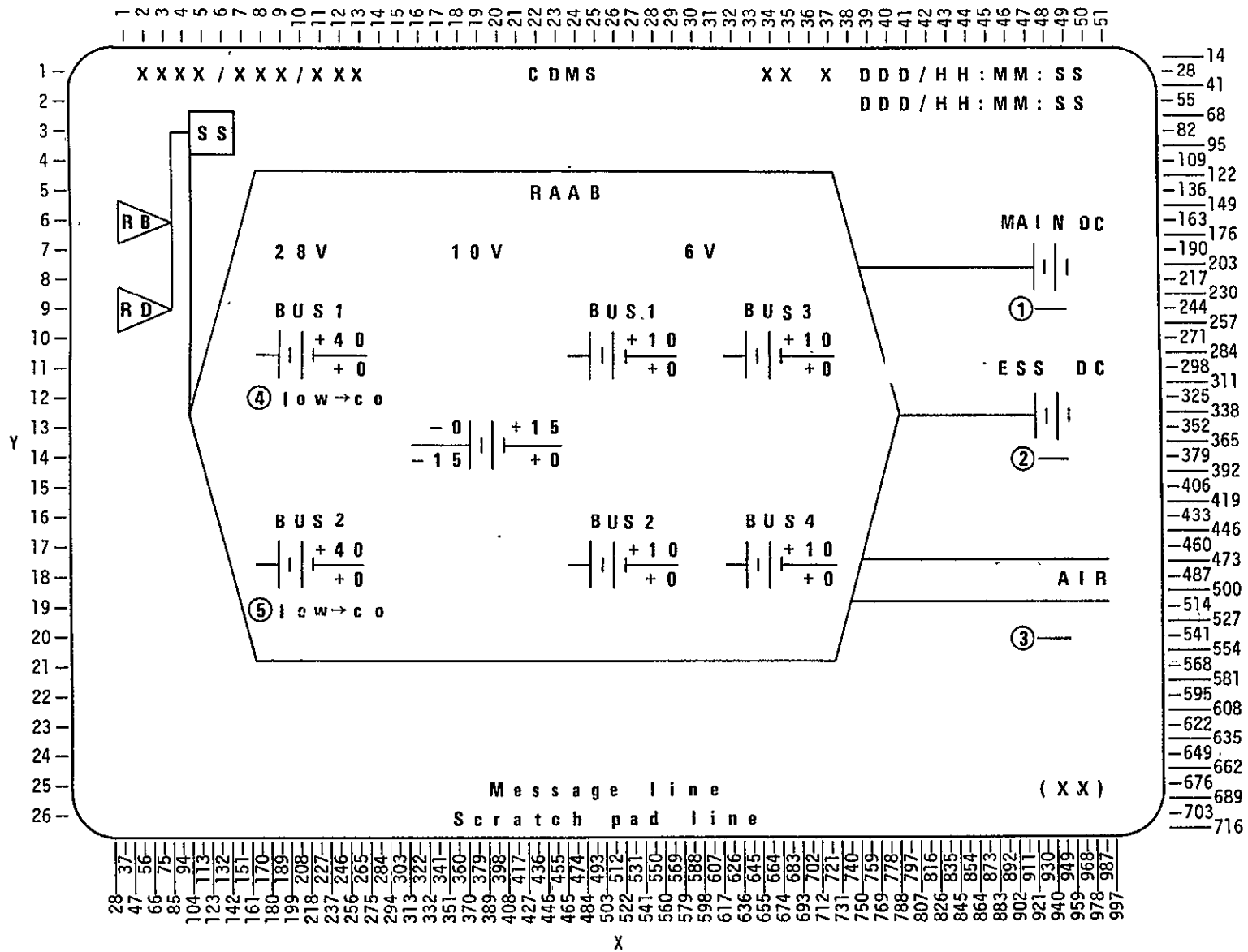

Figure 65.- RAAB activation display.

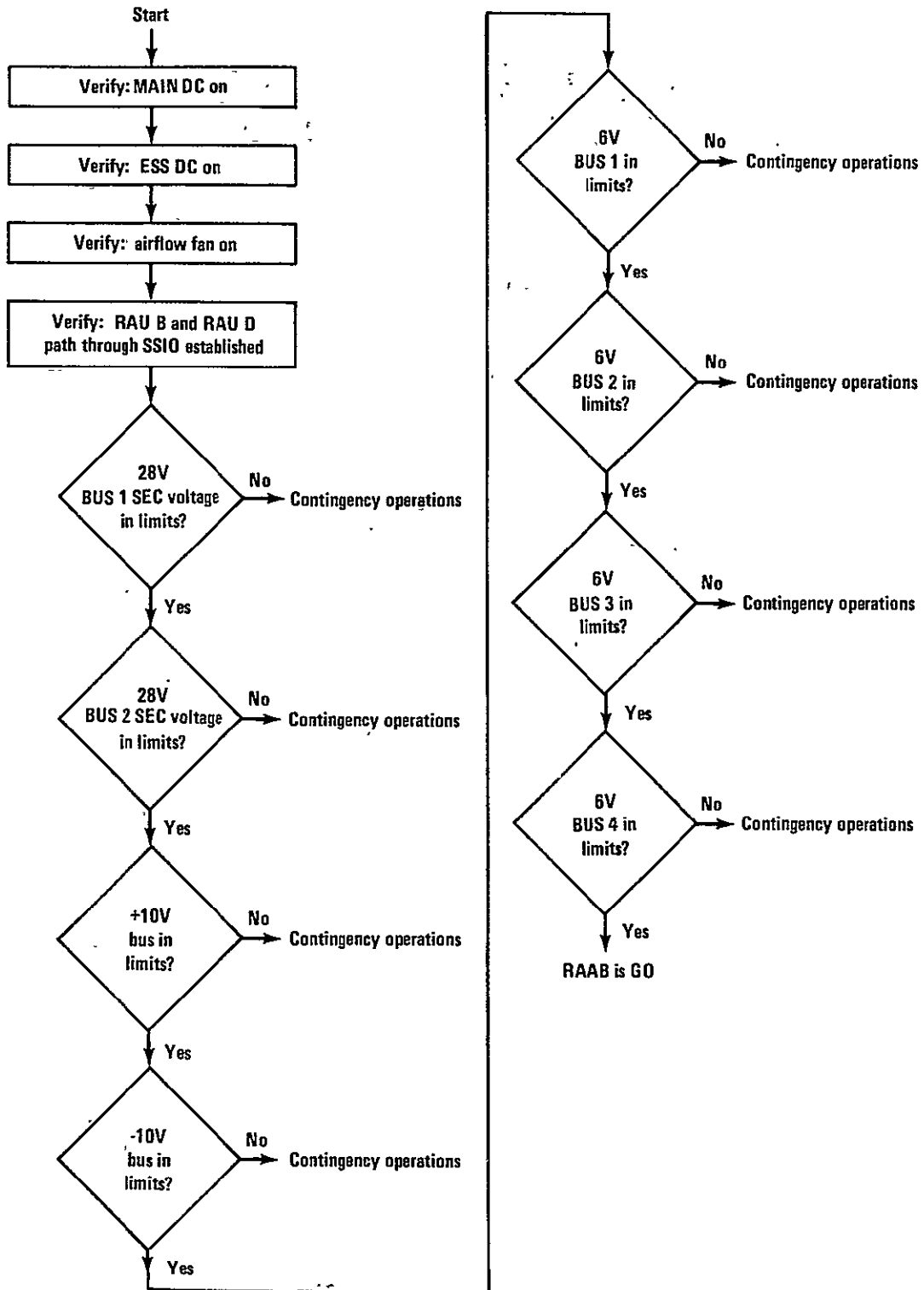

Figure 66.- RAAB monitoring and controlling flow chart.

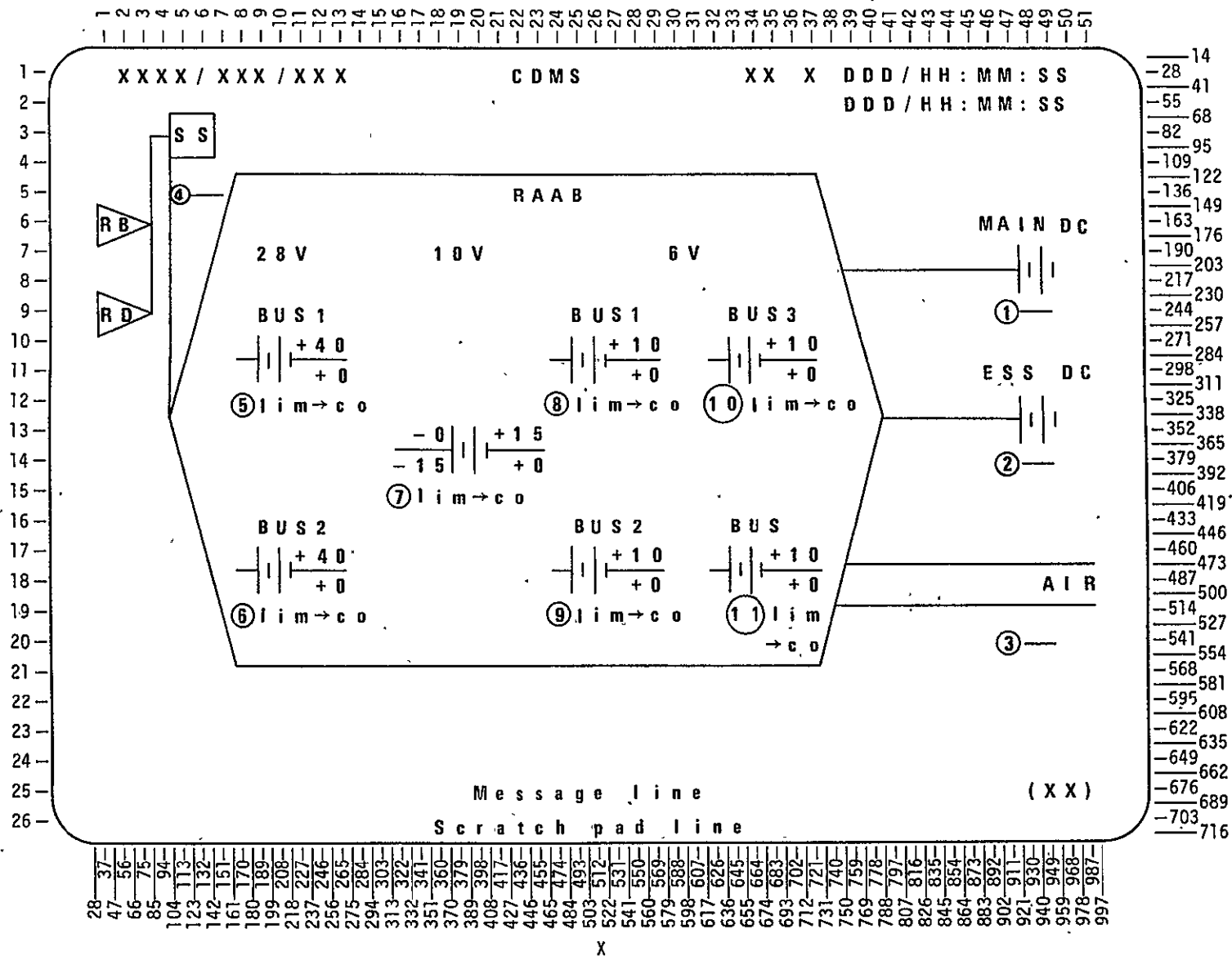

Figure 67.- RAAB monitoring and controlling display.

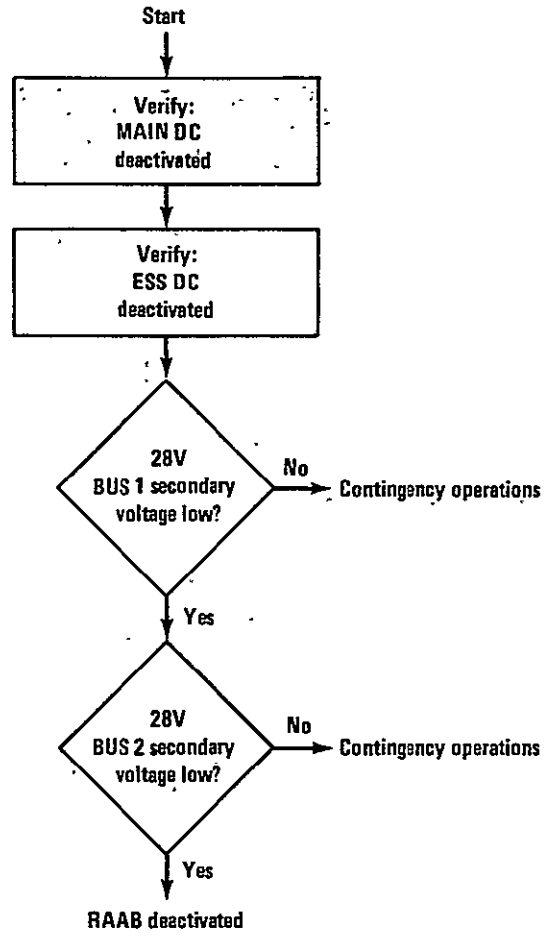

Figure 68.- RAAB deactivation flow chart.

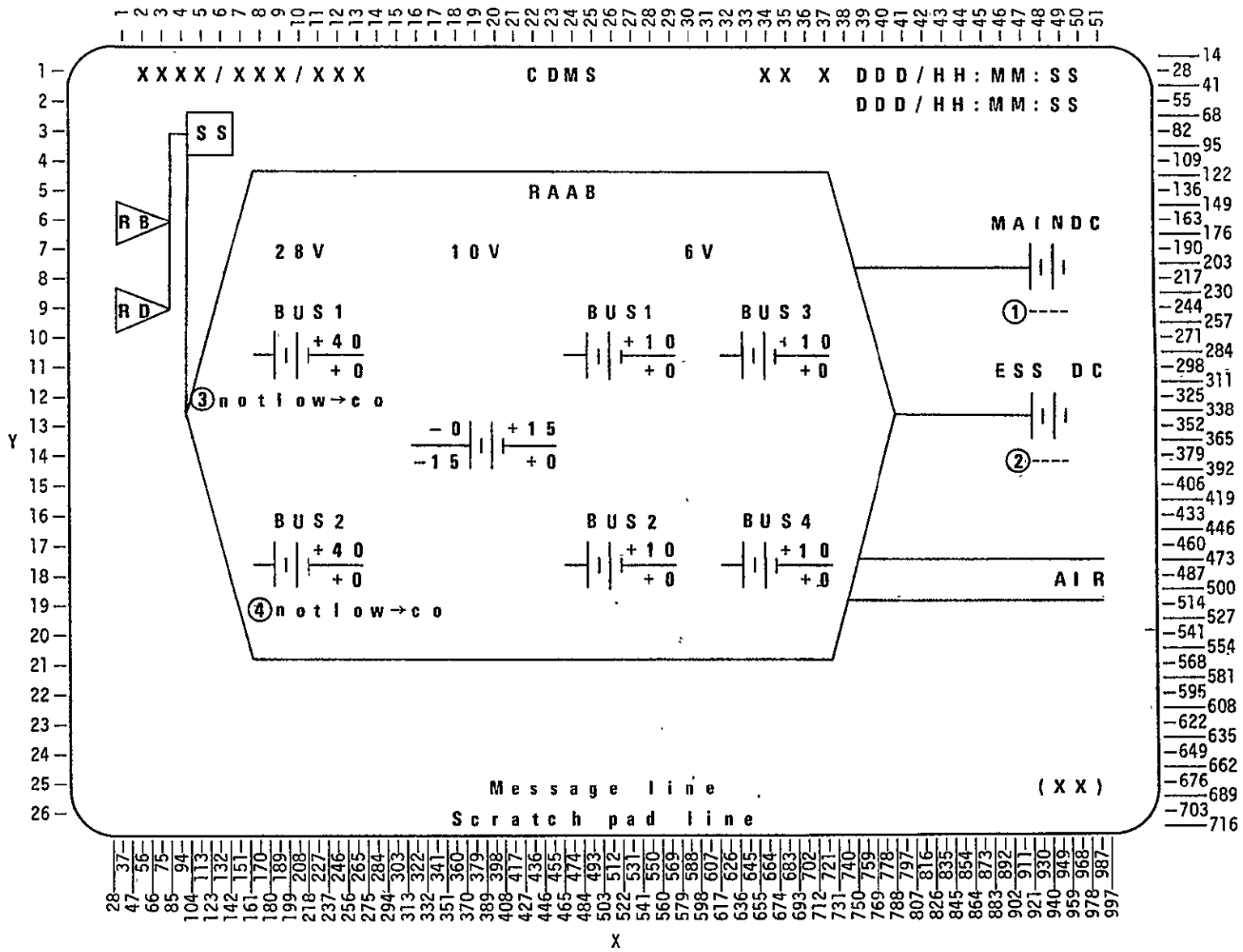
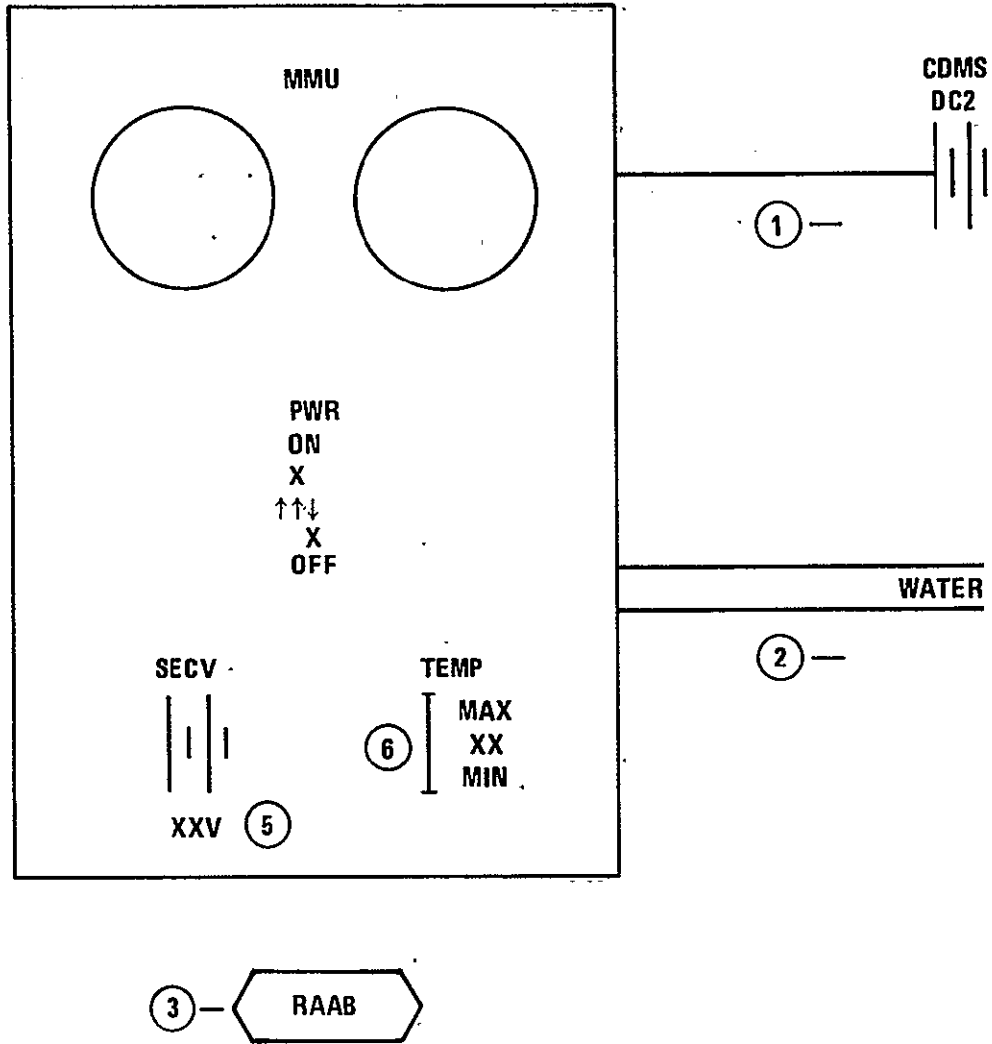
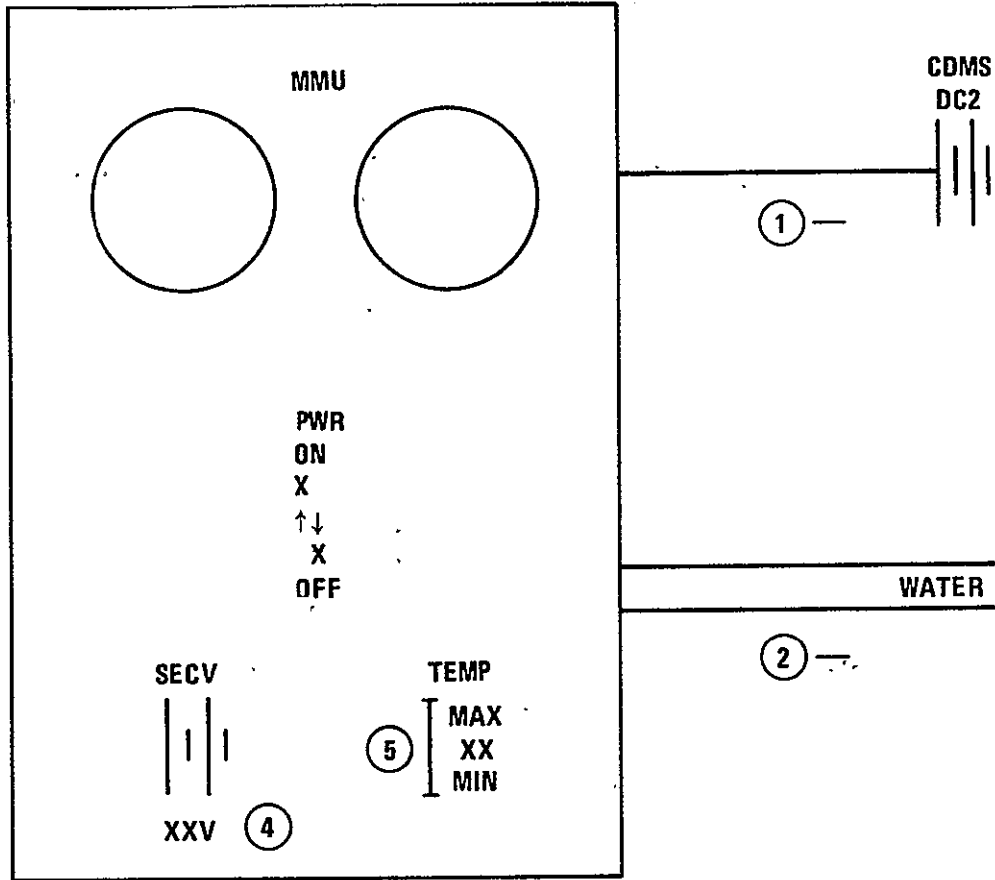

Figure 69.- RAAB deactivation display.



(a) Activation.

Figure 70.- MMU schematic displays with labels and tutorials.



(b) Monitoring and controlling.

Figure 70.- Continued.

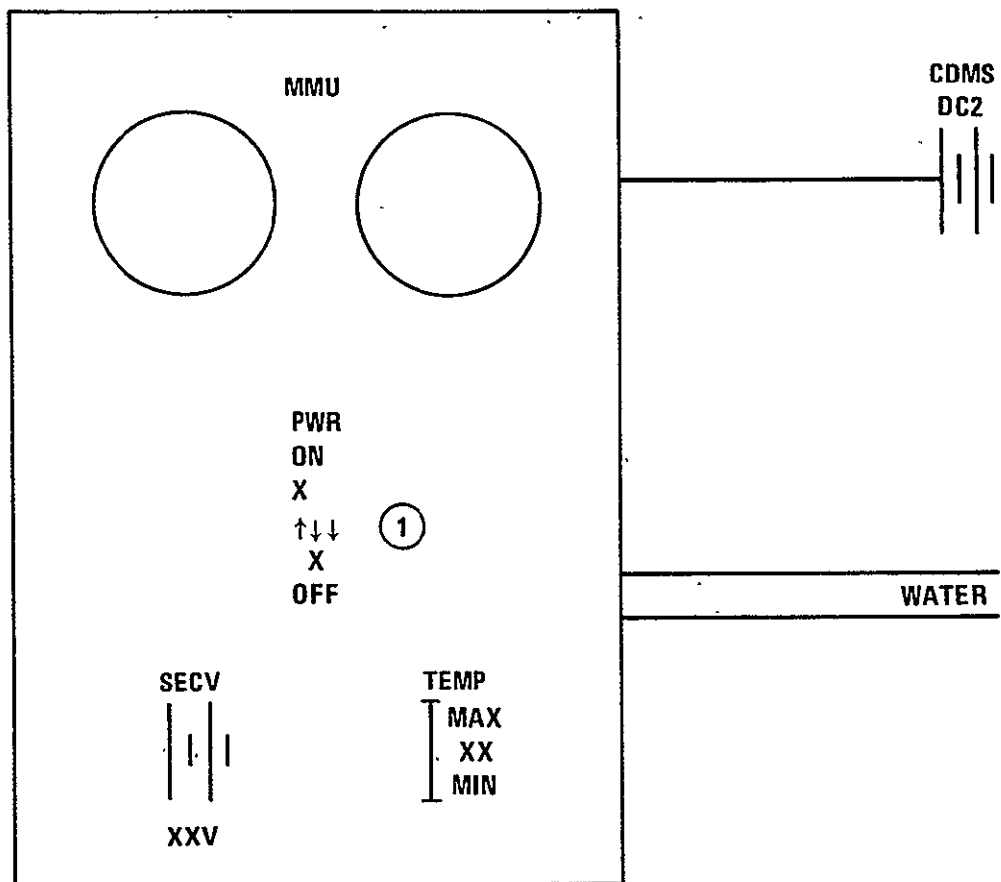

RAAB

(c) Deactivation.

Figure 70.- Concluded.

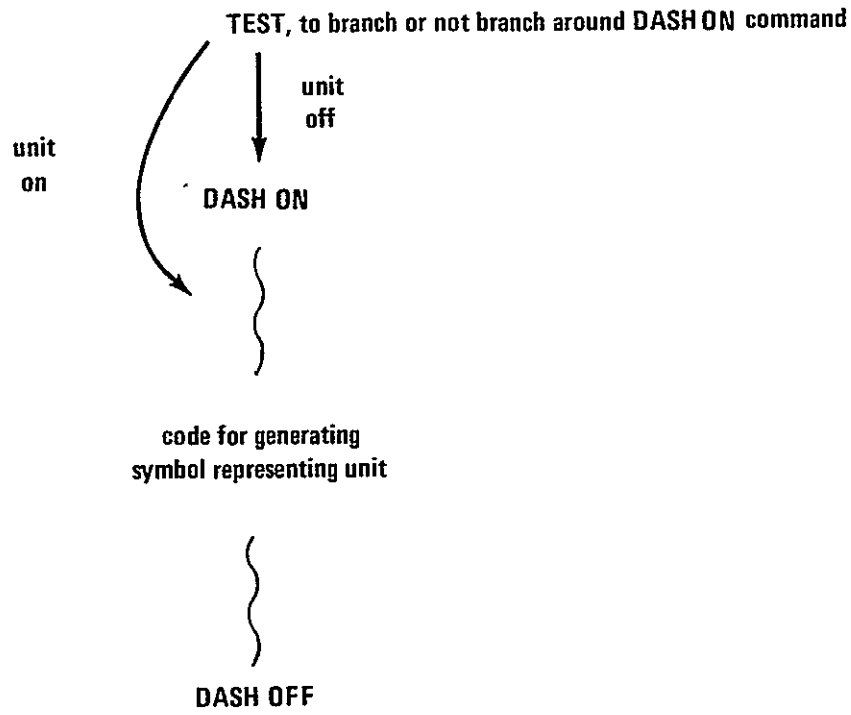

Figure 71.- Test to display symbol solid or dashed.

cf

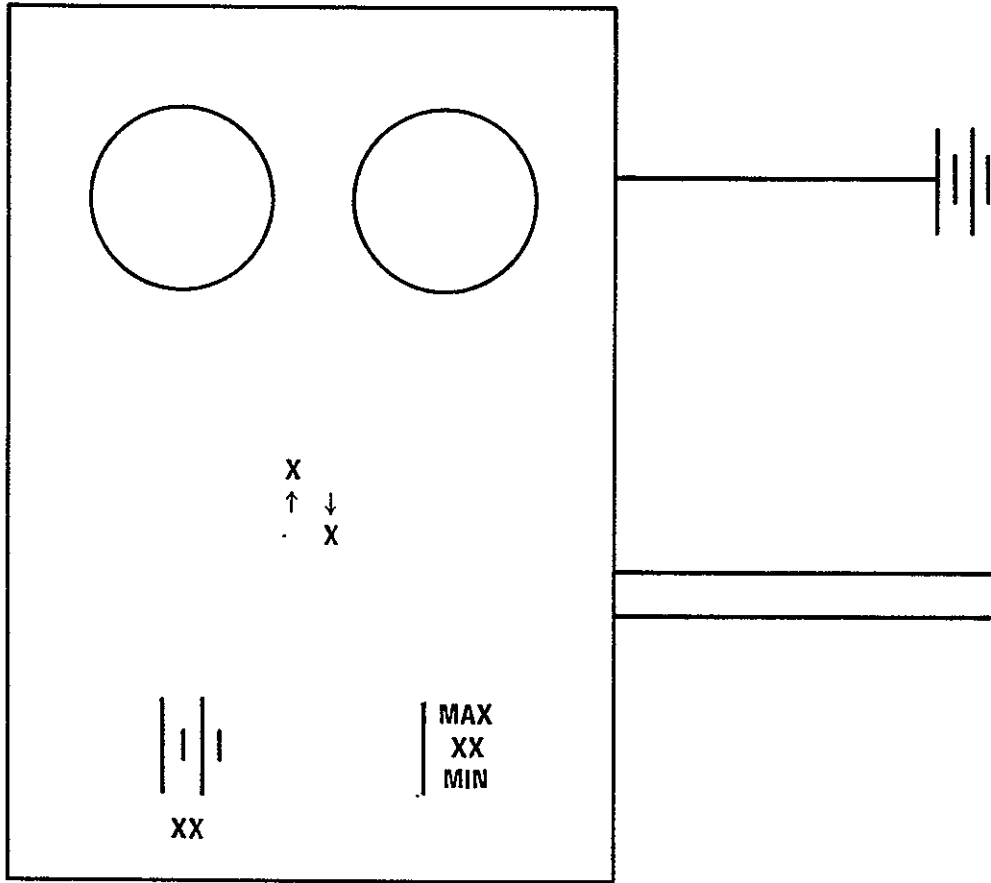

Figure 72.- MMU schematic display without labels and tutorials.

MMU

PWR	X ON *	X OFF *
SECV	XX V	
TEMP	MAX	XX MIN

	EXTERN	
	ON	OFF
CDMS DC2	*	*
WATER	*	*
RAAB	*	*

Figure 73.- MMU tabular display.

APPENDIX A

JUSTIFICATION FOR USING SCHEMATIC DISPLAYS

PAST INVESTIGATIONS

There is considerable evidence that data presented in picture form are superior for recall and recognition tasks to data in word form. Consider briefly some of the many, varied investigations that confirm this hypothesis. Shepard (ref. 2) showed subjects 600 pictures, sentences, or words and then tested them by showing them pairs, each pair consisting of a new and an old item. Pictures were more readily recognized than sentences or words. Nickerson (ref. 3) showed subjects a sequence of 600 photographs, each photograph being shown for only 5 seconds. Some duplicates were included after the first 200 photographs. The objective of the task was to determine whether a photograph had been seen before. The performance level was very high, even for recognizing duplicates separated by 200 other photographs and even after retention periods of a year. Standing, Conezio, and Haber (ref. 4) showed subjects 2560 photographs; each photograph was shown for 10 seconds. When tested with pairs, each pair containing a new and an old photograph, the subjects achieved a recognition performance level of more than 90 percent. The performance level remained high when each photograph was shown for only 1 second and then, in the testing phase, the mirror images of the old pictures were shown. Bower and Winzenz (ref. 5) found that in the learning of paired-associate words, for both recall and recognition tests and under short- and long-term conditions, subjects performed better when they formed vivid mental images of the two words interacting than when they used rote repetition, read connective sentences, or generated connective sentences for the pairs of words. Standing and Smith (ref. 6) found that subjects could learn pictures better than descriptions of the pictures. Paivio, Rogers, and Smythe (ref. 7) found that pictures could be recalled much better than words under conditions in which retention of 25 items was required for approximately 1 minute, starting from exposure to the first item. Benson and Steger (ref. 8), Paivio and Csapo (ref. 9), Sampson (ref. 10), and Scott (ref. 11) found that pictures are freely recalled more readily than concrete words, which in turn are more readily recalled than abstract words. Davies (ref. 12), Gorman (ref. 13), and Jenkins, Neale, and Deno (ref. 14), found that the same result is true for recognition tasks. Imagery mnemonics can also aid recall and recognition. Gupton and Frincke (ref. 15) and Mueller and Jablonski (ref. 16) found that imagery can aid the free recall of two-word phrases. Groninger, Bell, Cymer, and Wess (ref. 17) showed that paired-associate recognition is enhanced with the use of imagery, and Paivio (ref. 18) indicates that Simpson¹ and

¹Simpson, H. M.: Effects of Instructional Set, Encoding Time, and Word Type on Recognition Memory. Paper presented at meeting of the Canadian Psychological Association, Montreal.

Groninger² obtained similar results. Yarmey and Ure (ref. 19) found that concrete nouns are recalled better than abstract nouns. Paivio and Yarmey (ref. 20) found that in paired-associate recall, pictures are better stimuli than nouns. Yarmey and O'Neill (ref. 21) showed that imagery and noun specificity aid recall in paired-associate learning. Paivio and Rowe (ref. 22) found that concreteness of either or both of the members of an associative pair aids recognition tasks. Bower (ref. 23), Schnorr and Atkinson (ref. 24) Yuille and Paivio (ref. 25), and Paivio and Foth (ref. 26) found that imagery mnemonics for cued recall are superior to rote learning. Peterson and Murray (ref. 27) found that imagery can aid recall and recognition of nouns in paired-associate learning. Hollenberg (ref. 28) found that subjects with high imagery abilities were able to learn nonsense syllable names of objects faster than subjects with low imagery abilities. Paivio (ref. 18) indicates that Stewart,³ using picture digit pairs, obtained similar results. Begg (ref. 29) showed that the concreteness of words greatly aids the free recall of adjective-noun pairs. Paivio and Csapo (ref. 30), Nelson, Brooks, and Borden (ref. 31), and Snodgrass and Antone (ref. 32) showed that pictorial codes can aid memory for the sequential order of items. Gorman (ref. 13) found that concrete words are recognized more readily than abstract words. Paivio (ref. 18) indicates that pictures can be freely recalled approximately 100 percent better than words, that imaged words can be recalled approximately 100 percent better than pronounced words, that pictures can be recognized much better than words, and that imaged words can be recognized much better than words that are not imaged. Paivio, Yuille, and Rogers (ref. 33) found that in free recall, imagery of nouns has more effect than meaningfulness and that in serial recall, imagery of nouns has slightly more effect than meaningfulness. Paivio (ref. 34) found that in paired-associate learning, object pairs or picture pairs are easier to learn than pairs comprised of their concrete-noun labels. Dallet and Wilcox (ref. 35) showed that pictures can be freely recalled better than descriptions. Paivio (ref. 36) found that in paired-associate learning, concrete nouns were much easier to recall than abstract nouns. Sutherland (ref. 37) suggests that information displayed in a graphical form is often more useful than the same information displayed in a tabular form. He also indicates that "Diagrams, drawings, graphs, and sketches are essential tools for human understanding in many scientific and technical fields. Information formatted in inappropriate fashions can be very frustrating to human users." Martin (ref. 38) indicates that "When an operator becomes familiar with the use of shapes, he can take in a large amount of information at high speed from a screen that is well encoded. This can be of great value in fast, complex, and creative man-computer interaction."

²Groninger, L. D.: Storage and Retrieval Aspects of Imagery Instruction on Individual Words. Unpublished manuscript, University of Maryland, 1972.

³Stewart, J. C.: An Experimental Investigation of Imagery. Unpublished doctoral thesis, Univ. Of Toronto, 1965.

These experiments cover a wide range of conditions for complexity of items used, number of items used, familiarity of items used, length of retention intervals, retention intervals filled and unfilled by other tasks, recall and recognition tasks and many other experimental factors. Despite the many varied conditions, all these experiments indicate a common point that it is easier to handle information presented in a pictorial form than information presented in word form.

EXPERIMENTS

Some additional experiments were scheduled to be performed for further verification of the hypothesis that there should be pictorial displays for providing Space Shuttle crewmembers with information related to the status and configuration of the various Space Shuttle subsystems.

Consider the data processing subsystem (DPS). Crewmembers will be able to obtain DPS status and configuration information by viewing a display called the DPS configuration monitor,⁴ the general format of which is shown in figure A-1. Consider a hypothetical display consisting of a slight variation of two of the sections of the DPS configuration monitor. The general format of this display is illustrated in figure A-2. Only one redundant set (RS) may exist at a time. Each general-purpose computer (GPC) can be in either the halt, standby, or run mode, as specified by the MODE section (fig. A-1). However, for these experiments, it will be assumed that all five GPC's are in the run mode and capable of executing procedures. Therefore, in the experimental display in figure A-2, only the SET section is specified, each XX representing either an SX - which would indicate that the corresponding GPC is running simplex; that is, independently - or an RD - which would indicate that it is a member of an RS.

Of particular interest in these experiments are the four flight-forward (FF) multiplexers/demultiplexers (MDM's) and the four flight-aft (FA) MDM's. Figure A-3 illustrates the highly redundant nature of this network of links.

There are four possible data bus configurations, also called modes. These modes are illustrated in figure A-4. A string is in mode 6 if both primary (P) ports, and consequently both flight-critical (FC) buses, are in use. Mode 7 indicates that both secondary (S) ports and both FC buses are in operation. A string is in mode 8 if the FF S port, the FA P port, and consequently the high-numbered FC bus, are in use. Mode 9 indicates that the FF P port, the FA S port and the low-numbered FC bus are in operation. For String 5, mode 6 has PF1 1 port and PF2 2 port in operation, mode 7 uses PF1 2 port and PF2 1 port, mode 8 operates with PF1 2 port and PF2 2 port, and mode 9 has PF1 1 port and PF2 1 port in operation.

⁴NASA, ALT Level C, Functional Subsystem Software Requirements, Displays and Controls Display Formats. Contract NAS 9-14000, SD 74-SH-0296A, Feb. 28, 1975.

Each string can be assigned to a single GPC, regardless of whether that GPC is in an RS or not, by using the COMPUTER/BUS key (C/B) on one of the keyboard units.⁵ The sequence of keystrokes would be C/B A B ETR, where B is the number of the string being assigned to GPC number A. ETR is a special key, ENTER, which indicates the end of an instruction sequence. A string can be assigned to any GPC, and any GPC can be in control of any number of strings; however, a string can only be assigned to one GPC at a time. The mode of the string can then be specified also by using the sequence of keystrokes C/B A B ETR; however, here A is the number of the string and B is the mode into which string A is to be configured. In the display illustrated in figure A-2, the v's, w's, x's, y's, and z's would be changed to 1, 2, 3, 4, or 5, depending on which GPC is controlling that string. Because only one port of each MDM can be in operation at a time, only one of each of the pair of possible locations for numbers in each column for each MDM would be used. The unused locations would be blank. For example, the section illustrated in figure A-5 indicates that string 3 is assigned to GPC 5 and is in mode 9.

As an alternative to the display illustrated in figure A-2, a pictorial display that provides exactly the same information is illustrated in figure A-6. Each string is displayed as a vertical group of three rectangles. The four possible modes can be easily identified and are illustrated in figure A-7. These four geometric patterns also apply to String 5. The computer controlling each string is represented by the appropriate single digit centered inside the middle rectangle of each string. If the middle rectangle is blank, then that string is not being used. For example, the section illustrated in figure A-8 indicates that String 3 is assigned to GPC 5 and is in mode 9.

If an RS exists, then one of the GPC's in the RS is designated as the prime GPC; that is, as the lead GPC of the RS. For these experiments, it will be assumed that a crewmember would form an RS by entering the sequence of keystrokes "OPS - ETR," where "-" represents two, three, or four single digits, each digit specifying the number of a GPC in the RS. To indicate that no RS is to be used, the sequence of keystrokes "OPS 0 ETR" would be entered. String 5 is only in use if an RS exists, and String 5 is always controlled by the prime GPC of the RS. Therefore, to specify which GPC is to be the prime GPC, after forming the RS, a crewmember would just indicate that String 5 is to be controlled by the GPC that is to be the prime GPC. In the display illustrated in figure A-2, the RS can be identified from the SET section and the prime GPC can be identified by determining which GPC is controlling String 5. In the display illustrated in figure A-6, the rectangle in the center of the section representing String 5 will contain the numbers of all the GPC's in the RS. The number specifying the prime GPC will be displayed brighter than the other numbers. For example, figure A-9 indicates that the RS consists of GPC's 1, 3, and 5, that GPC 3 is the prime GPC, and that String 5 is in mode 9.

⁵NASA, Space Shuttle Program, Orbiter Project, Computer Program Development Specification. Vol. 1, Book 2, System Level Description, Software. Contract NAS9-14000, SS-P-0002-120A, June 20, 1975.

There are two important points about the pictorial display illustrated in figure A-6 that should be considered. First, this display format was carefully designed so that it would provide exactly the same information that the display illustrated in figure A-2 provides, except that the display in figure A-2 provides the information in a tabular form and the display in figure A-6 provides the information in a pictorial form. This equality of information provided is essential to the experiments because it must be assured that neither type of display format is given an advantage by providing extra information that could aid a subject in the tasks to be performed, or irrelevant information that could confuse a subject. The second important point is that no attempt was made to design the display illustrated in figure A-6 so that it would provide pictorial discrimination of items at a level lower than the string or mode level, or so that it would provide highly redundant coding of information. That is, for example, FF and FA MDM's could have been made different shapes or colors so that they could be more easily distinguished, each string could have been made a different color or been given a different angular orientation, or the two buses in each string could have been drawn by using different line types - for example, the low-numbered buses could have been dotted lines and the high-numbered buses dashed lines. These are just some general changes that could have been made and are only hypothetical because, for example, the real Space Shuttle cathode ray tube (CRT) system has no ability to display different colors. The objective was just to design a display that is clearly nontabular and provides the mode and GPC assignment information relating to the strings in a pictorial form.

Now that the two types of displays have been described, it is possible to examine the experiments that were performed to determine which type of display would be most efficient in providing crewmembers with information related to the configuration of the GPC's, the MDM's, and the data buses - the tabular display illustrated in figure A-2 or the pictorial display illustrated in figure A-6.

Experiment 1

Subject.- It could be assumed that any Space Shuttle crewmember would be highly trained in the use of the crew/DPS interfaces, would be familiar with the wide variety of configurations that the DPS could be in, and would also be a highly motivated DPS operator. Therefore, it was initially considered reasonable to use the author as the subject rather than a subject who would not be familiar with the DPS and who might not be very motivated. However, problems were encountered concerning this assumption; and to validate the data obtained in experiment 1, experiment 2 was performed with an untrained operator.

Materials.- Three sets of displays were required. The first set consisted of 18 different DPS configurations represented in the tabular format illustrated in figure A-2. After the basic format was copied onto 18 sheets of ordinary 8-1/2 by 11-inch white duplicating paper, the specifics of each configuration were completed in black ink. Tables of random numbers were used for each configuration to determine which GPC's were to be in the RS for

each string (or that no RS was to be used), which GPC would be controlling it, and which mode it would be in; or that the string would not be used and if an RS was to exist, which GPC would be designated as the prime GPC. The procedure for constructing these configurations with the use of random numbers was carefully developed so that a reasonable cross section of possible DPS configurations would be produced.

The next step was to take each of the 18 tabular displays and produce a pictorial display that would represent the same DPS configuration. The basic pictorial display format illustrated in figure A-6 was copied onto ordinary 8-1/2 by 11-inch white duplicating paper and the specifics of each configuration were completed in black ink.

There are many tasks that could be performed in an attempt to determine how efficiently the tabular and pictorial displays present information related to the various DPS configurations. The task chosen was to take each configuration and simulate the sequence of keystrokes that would be required to produce that configuration. The speed and accuracy of using the tabular and pictorial displays could then be compared. To simulate operating the Space Shuttle keyboard, an ordinary four-function pocket calculator was used. However, several of the special-purpose keys necessary for the experiment are specific to the Space Shuttle keyboard. The functions of those keys were simulated by relabeling keys on the calculator such that the correct sequence of keystrokes for an entire DPS configuration would produce a number on the calculator display that could be associated with that configuration. To perform arithmetic on the calculator, the infix form for binary operations was used. That is, to add 2 and 3, the keystrokes would be $2 + 3 =$. This calculator could also perform unary subtraction. That is, to subtract negative 3 from negative 2, the keystrokes would be $-2 - 3 =$. The CLEAR key on the calculator was relabeled as PROCEED (PRO). For these experiments, PRO was interpreted as meaning "proceed to the calculations for this configuration" and would be pressed once before work was started on each configuration. The minus key was relabeled as OPS.

The first instruction entered for each configuration was to specify the GPC's in the RS. Therefore, unless no RS was to be used, the first number entered would be a two-, three- or four-digit negative number. If no RS was to exist in the configuration, then a zero would be entered. The plus key was relabeled as ETR. Therefore, every number entered after the RS specification would be added to the initial negative or zero. The decimal point key was relabeled as C/B. Therefore, all the numbers added to the initial value were of the form .XX. The final number displayed, which would be the number associated with the configuration, would be either a large negative number or a small positive number. Although this scheme for numbering the configurations did not guarantee uniqueness of the numbers, no two configurations had the same number. Each configuration was taken, and the pictorial display was used to produce the associated number, which was then printed in blue ink in the lower right corner of the tabular and pictorial displays.

The objective of this experiment was to compare the efficiency of the tabular display format with that of pictorial display format. To accomplish this comparison, it was necessary to develop a corresponding set of control

displays that would make it possible to determine the extent of nonmental processing in the task. As each pictorial display was drawn from the corresponding tabular display, a control display was also produced. Each control display consisted of an ordinary 8-1/2 by 11-inch sheet of white duplicating paper on which was written the entire sequence of keystrokes to be made for the corresponding configuration. These keystrokes were written in black ink, in a vertical list, one instruction on each line, and with the associated number for the corresponding configuration written in blue ink at the bottom of the list.

To make sure that neither type of display would be favored by allowing more pretrial learning for one than for the other, the tabular displays were drawn first, from them the pictorial and control displays were created, and from the pictorial displays the numbers associated with each display were calculated. Therefore, each tabular and pictorial display was reviewed twice before the start of the experiment. The control displays were only reviewed once, but because the control displays were designed with the intention that a minimal amount of mental processing would be required during use, only having one review instead of two would probably not have any significant effect.

Method. - There were six trials. The three sets of displays - tabular, pictorial, and control - were used in each trial. A table of random numbers was used to determine the order of the six possible permutations of the three sets of displays.

Each trial was accomplished at a single sitting, to maintain conditions such as environmental setting, degree of fatigue, and motivation.

Before each trial, the 3 sets of 18 displays were each thoroughly shuffled.

The procedure for doing each set of displays in a trial was such that the first 3 displays were practice and then the remaining 15 displays were timed with a stopwatch accurate to 0.1 second. In addition, the number of errors made were noted. An error was usually detected by observing that the final number on the calculator display did not correspond to the number written in blue on the sheet currently being worked on. However, if an error was detected before the end of the calculations was reached for a display, a rule had been established that the calculations for that display were to be completed as if no error had been made. This procedure removed the possibility that errors detected before the end of the calculations for displays would cause a reduction in the total time for the set of displays.

To maintain the amount of time it took to check each instruction before pressing the ETR key, a ground rule was established specifying that before pressing the ETR key, the subject must view the calculator display to check that the correct sequence of keystrokes has been entered. This rule prevented the subject from performing the operations quickly at certain times, without checking the calculator display, and more slowly at other times when the calculator display was checked. In addition, it is probably reasonable to assume that any Space Shuttle crewmember operating a CRT and keyboard

would use the scratch-pad line on the CRT, which displays the sequence of keystrokes entered,⁶ to check an instruction before entering it.

When the calculations for a display were made, the strings did not necessarily have to be handled in numerical order; however, they always were because it was more convenient to do so.

Results.- The results are presented in table A-1. This table indicates the order in which the sets of displays were done in each trial, the amount of time it took, in minutes and seconds, to do each set of displays, and the number of errors made in doing each set of displays.

To compare the mental processing time for the tabular and pictorial displays, the nonmental processing time - that is, the time for the control displays - must be subtracted from each.

Let

$T(d) =$ the total time for displays of type d

Let

$PT(d) =$ the total mental processing time for displays of type d

For all six trials combined together,

$$T(\text{tab}) = 3772.5 \text{ sec}$$

$$T(\text{pic}) = 2813.8 \text{ sec}$$

$$T(\text{con}) = 2643.6 \text{ sec}$$

$$PT(\text{tab}) = T(\text{tab}) - T(\text{con}) = 3772.5 \text{ sec} - 2643.6 \text{ sec} = 1128.9 \text{ sec}$$

$$PT(\text{pic}) = T(\text{pic}) - T(\text{con}) = 2813.8 \text{ sec} - 2643.6 \text{ sec} = 170.2 \text{ sec}$$

$$PT(\text{tab})/PT(\text{pic}) = 1128.9 \text{ sec}/170.2 \text{ sec} = 6.63$$

⁶See footnote 5.

Therefore, the mental processing time required for the tabular displays was 6.63 times that required for the pictorial displays.

It is difficult to analyze the errors. There were no errors for the control displays; so this result implies that there was no problem in operating the keyboard. There was a total of 10 errors for the tabular displays and 5 for the pictorial displays, a ratio of 2:1.

If trial 1 is compared to the other five trials, some discrepancy is observed in that, for trial 1, the time for the pictorial displays was less than the time for the control displays. This result can be attributed to the subject's experiencing learning during the first trial. This result might make trial 1 somewhat invalid; so it could be advantageous to recalculate the mental processing times, but only for trials 2 to 6. If this recalculation is done, the values obtained are

$$PT (\text{tab}) = 851.2 \text{ sec}$$

$$PT (\text{pic}) = 228.8 \text{ sec}$$

$$PT (\text{tab})/PT (\text{pic}) = 851.2 \text{ sec}/228.8 \text{ sec} = 3.72$$

Therefore, for trials 2 to 6, the mental processing time required for the tabular displays was 3.72 times that required for the pictorial displays. There were eight errors while the tabular displays were used and three while the pictorial displays were used. This ratio is 2.67:1.

It can also be seen that beginning with trial 4, the times seem to stabilize. In addition, the subject felt that by trial 4, he was doing each set of displays as quickly as it would have been possible for him to do them. If the mental processing times are recalculated, with only trials 4 to 6 used, the values obtained are as follows.

$$PT (\text{tab}) = 348.5 \text{ sec}$$

$$PT (\text{pic}) = 50.7 \text{ sec}$$

$$PT (\text{tab})/PT (\text{pic}) = 348.5 \text{ sec}/50.7 \text{ sec} = 6.87$$

Therefore, for trials 4 to 6, the mental processing time required for the tabular displays was 6.87 times that required for the pictorial displays. It is possible that this result is the most valid ratio of the three calculated. There were four errors made while the tabular displays were used and two made while the pictorial displays were used, a ratio of 2:1.

Discussion.- In all three sets of trials considered, all six trials, trials 2 to 6, and trials 4 to 6, although the values were different,

the pictorial displays required significantly less mental processing time and resulted in fewer errors than the tabular displays. A great attempt was made by the subject not to be influenced by the knowledge that the pictorial displays should be more efficient to use than the tabular displays.

It was quickly realized, before the first trial began, that a certain amount of visual coding could be used when operating with the tabular displays. This visual coding took the form of being able to determine the mode of each string by observing the relative positions of the digits specifying the controlling GPC for each string. These visual codes are illustrated in figure A-10. Although it is known that these visual codes greatly aided the subject in determining the mode of each string, it is difficult to even guess at a quantity that would answer the question, "How much did the codes help?"

In an attempt to answer this question and also to verify the results obtained in experiment 1, it was decided to do a second experiment.

Experiment 2

Subject.- The subject was a 21-year-old male college junior, majoring in geology, previously unfamiliar with the Space Shuttle DPS and unaware that the pictorial displays should be more efficient to use than the tabular displays.

Materials.- The same materials were used as in experiment 1.

Method.- The method was basically the same as for experiment 1. There were three trials instead of six. Trials 2 and 3 were each accomplished at a single sitting. However, because of the time involved to explain the procedure for using each type of display, trial 1 was accomplished at three separate sittings, one sitting for each type of display.

Results.- The results, presented in table A-2, are similar to the results of experiment 1 except that the times were longer because of the unfamiliarity of the subject with the procedures.

The values obtained for all three trials are as follows.

$$PT (\text{tab}) = 797.0 \text{ sec}$$

$$PT (\text{pic}) = 466.5 \text{ sec}$$

$$PT (\text{tab})/PT (\text{pic}) = 797.0 \text{ sec}/466.5 \text{ sec} = 1.70$$

Therefore, the mental processing time required for the tabular displays was 1.70 times that required for the pictorial displays. There were two errors made in using the control displays. However, this occurrence transpired in the first set of the first trial, and the subject did report

having some difficulty in locating the appropriate keys on the keyboard. There were three errors made in using the tabular displays and four in using the pictorial displays. Because this variation is so small and some errors were made in using the control displays, the effect on error rate could probably be considered equal for both types of displays.

The times for trial 1 are very long compared to the times for trials 2 and 3. The subject did report that during trial 1 a considerable amount of time was spent learning both the location of the keys on the keyboard and the procedures used. Therefore, the validity of trial 1 is questionable, and it might be advantageous to consider the values obtained for only trials 2 and 3, which are as follows.

$$PT (\text{tab}) = 475.8 \text{ sec}$$

$$PT (\text{pic}) = 157.5 \text{ sec}$$

$$PT (\text{tab})/PT (\text{pic}) = 475.8 \text{ sec}/157.5 \text{ sec} = 3.02$$

Therefore, for trials 2 and 3, the mental processing time required for the tabular displays was 3.02 times that required for the pictorial displays. There were no errors made in using the control displays, one error was made in using the tabular displays, and one error was made in using the pictorial displays. As in the analysis for all three trials, the effect on error rate seems to be equal for both types of displays.

Discussion.— It does not appear that the times had stabilized by trial 3. What the stable values would have been and how many trials it would have taken to reach them is not known.

After the experiment, the subject was questioned as to whether, when using the tabular displays, he had become aware of and used the potential visual codes for determining the mode for each string. He reported that he was not aware of the codes.

General Discussion

The question to be answered now is whether the results of experiments 1 and 2 are really valid.

Would more trials have added to the validity of the values obtained? In experiment 1, after trial 3, the values stabilized. The subject also felt that he was doing the calculations as quickly as it would have been possible for him to do them. Therefore, it is unlikely that more trials would have produced different results, at least with the trained subject.

Would having more display configurations in each set have added to the validity of the values obtained? Even after six trials in experiment 1, the

subject did not feel sufficiently familiar with any of the display configurations to the point that he was aided in performing the calculations. Therefore, it would probably only be necessary to add additional configurations to each set if the number of trials was increased.

Would using more subjects have added to the validity of the results obtained? Experiment 2, for the most part, does confirm the results obtained in experiment 1. However, it can be assumed that any Space Shuttle crewmembers operating the DPS would be highly trained. Therefore, the use of additional subjects might only be advantageous if they were trained subjects.

Would using displays of other aspects of a Space Shuttle subsystem, combinations of displays, or different calculations to be performed have added to the validity of the results obtained? Undoubtedly, additional tests, varying all these factors, would be very valuable. For very extensive testing, it would be highly advantageous to have a real-time computer simulation, with a CRT and simulated Space Shuttle keyboard, to provide the displays.

Conclusion

Experiments 1 and 2 show that the general concept that information presented in pictorial form is superior for use in performing memory tasks to information presented in word form can be made more specific to state the hypothesis that schematic displays for providing Space Shuttle crewmembers with information related to the status and configuration of various Space Shuttle subsystems would be superior to tabular displays for use in performing many tasks.

TABLE A-1.- EXPERIMENT 1 RESULTS

Display	Time, min:sec	No. of errors
Trial 1		
Control	10:09.6	0
Tabular	14:43.7	2
Pictorial	9:11.0	2
Trial 2		
Pictorial	8:46.3	1
Control	6:52.9	0
Tabular	10:36.5	1
Trial 3		
Tabular	11:23.5	3
Pictorial	7:49.1	0
Control	6:44.4	0
Trial 4		
Control	6:53.7	0
Pictorial	7:07.3	0
Tabular	8:58.9	1
Trial 5		
Pictorial	7:05.1	1
Tabular	8:30.6	2
Control	6:50.9	0
Trial 6		
Tabular	8:35.7	1
Control	6:32.1	0
Pictorial	6:55.0	1

TABLE A-2.- EXPERIMENT 2 RESULTS

Display	Time, min:sec	No. of errors
Trial 1		
Control	11:49.9	2
Pictorial	16:58.9	3
Tabular	17:11.1	2
Trial 2		
Pictorial	9:33.2	0
Tabular	11:33.7	0
Control	8:37.5	0
Trial 3		
Pictorial	10:46.3	1
Control	9:04.5	0
Tabular	14:04.1	1

```

1- XXXX/0001/XXXX DPS CONFIG-MONITOR X DDD/HH:MM:SS
2- 1 2 3 4 FLD GPC DDD/HH:MM:SS
3- MODE XX XX XX XX 1 X X X X
4- SET XX XX XX XX VTG2 X X X X 21 TLM GPC
5- MF XX XX XX XX GPC3 X X X X
6- XX XX XX XX 4 X X X X FREEZE DRY
7-VTR SHTDN RST X X X XS 22 QVLY GPC
8- ENA 1X 2X 3X 4X CPU XX XX XX XS 23 LOAD GPC
9- INH 5X 6X 7X 8X GPC BUS MDM GPC BUS MDM
10-TMR SHTDN 24 X FC1FF1PXS
11- ENA 9X10X11X12X25 X FC5FF1SXS 37 X FC5FA1PXS
12- INH 13X14X15X16X26 X FC2FF2PXS
13-OVLY X X X X 27 X FC6FF2SXS 38 X FC6FA2PXS
14-OPS OVLY GPC 28 X FC3FF3PXS
15- G1 1 17 29 X FC7FF3SXS 39 X FC7FA3PXS
16- G2 2 18 30 X FC4FF4PXS
17- S8 3 19 31 X FC8FF4SXS 40 X FC8FA4PXS
18- S9 4 20 32 X PL1PF1PXS 41 X PL1PF2SXS
19- 33 X PL2PF1SXS 42 X PL2PF2PXS
20- 34 X LB1LF1PXS X LB1LA1SXS
21- 35 X LB2LF1SXS X LB2LA1PXS
22- MMU 1 MMU 2 36 X MM1MMU1XS 43 X MM2MMU2XS
23- XXXXXXXXXXXXXXXX 44 BUS RECONFIG
24-
25- (XX)
26-
!!!!!!!!!!!!!!!!!!!!!!!!!!!!!!!!!!!!!!!!!!!!!!!!!!!!!!!!!!!!!!!!!!!!
123456789012345678901234567890123456789012345678901
111111111122222222223333333333334444444444455

```

Figure A-1.- DPS configuration monitor.

		GPC							
		1	2	3	4	5			
SET		XX	XX	XX	XX	XX			
GPC	BUS	MDM	GPC	BUS	MDM				
v	FC1	FF1P	v	FC1	FA1S				
v	FC5	FF1S	v	FC5	FA1P				
w	FC2	FF2P	w	FC2	FA2S				
w	FC6	FF2S	w	FC6	FA2P				
x	FC3	FF3P	x	FC3	FA3S				
x	FC7	FF3S	x	FC7	FA3P				
y	FC4	FF4P	y	FC4	FA4S				
y	FC8	FF4S	y	FC8	FA4P				
z	PL1	PF11	z	PL1	PF21				
z	PL2	PF12	z	PL2	PF22				

Figure A-2.- Hypothetical variation of DPS configuration monitor.

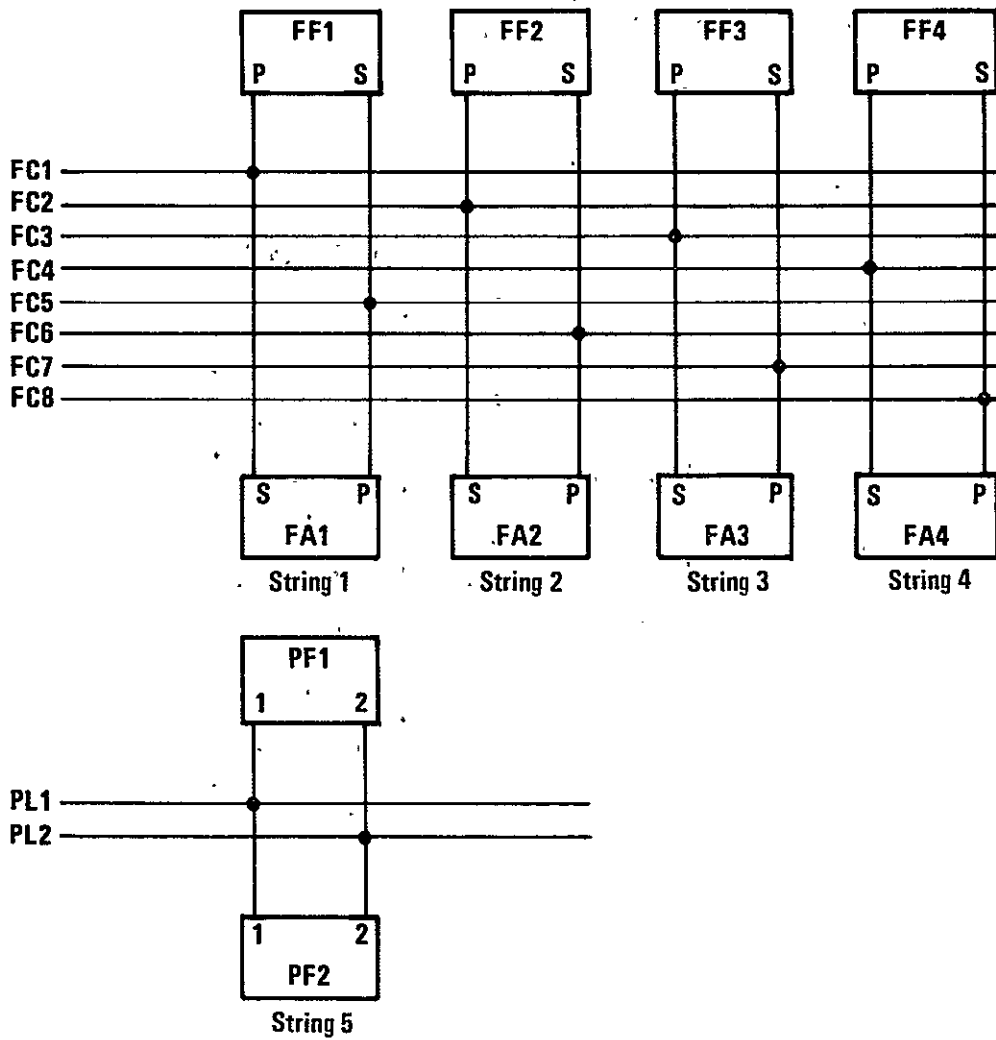
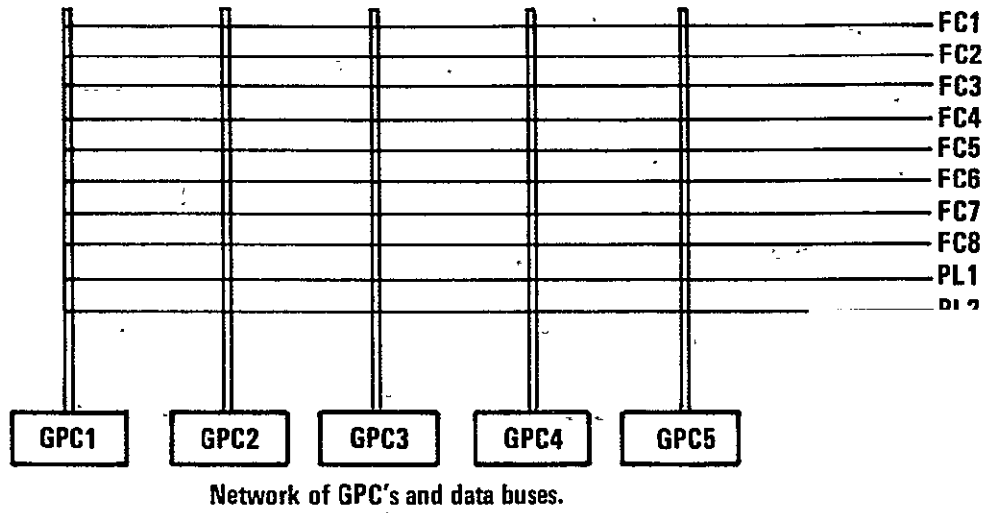

Figure A-3.- Organization of GPC's, data buses, and MDM's.

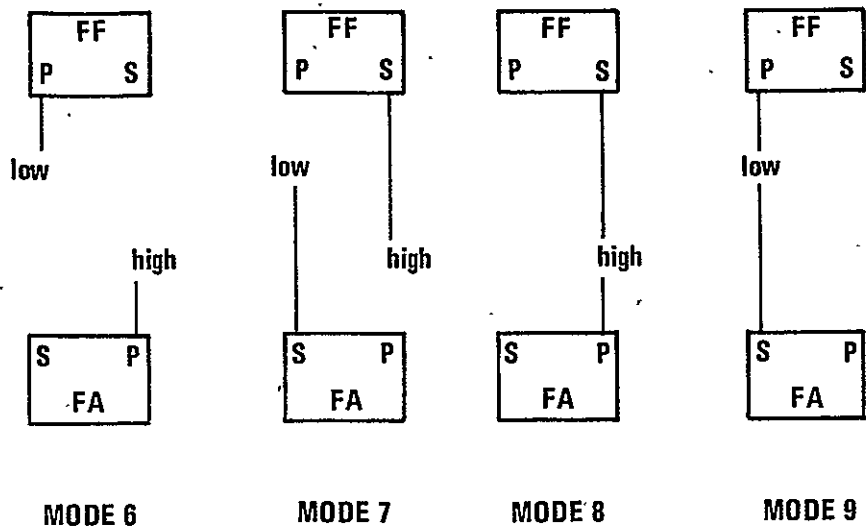

Figure A-4.- The four possible modes of the strings.

GPC	BUS	MDM	GPC	BUS	MDM
•	•	•	•	•	•
•	•	•	•	•	•
•	•	•	•	•	•
5	FC3 FC7	FF3P FF3S	5	FC3 FC7	FA3S FA3P
•	•	•	•	•	•
•	•	•	•	•	•
•	•	•	•	•	•

Figure A-5.- Example of tabular mode indication. String 3 is assigned to GPC 5 and is in mode 9.

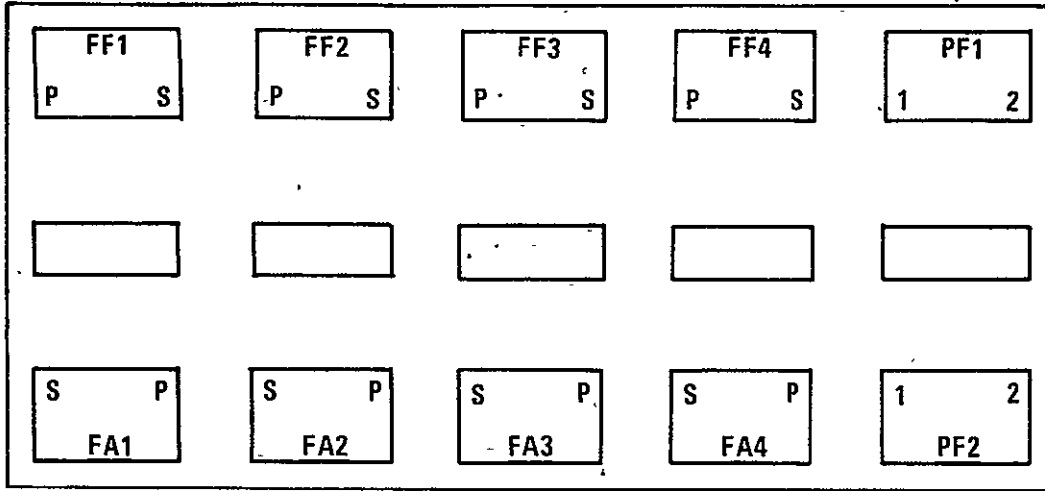
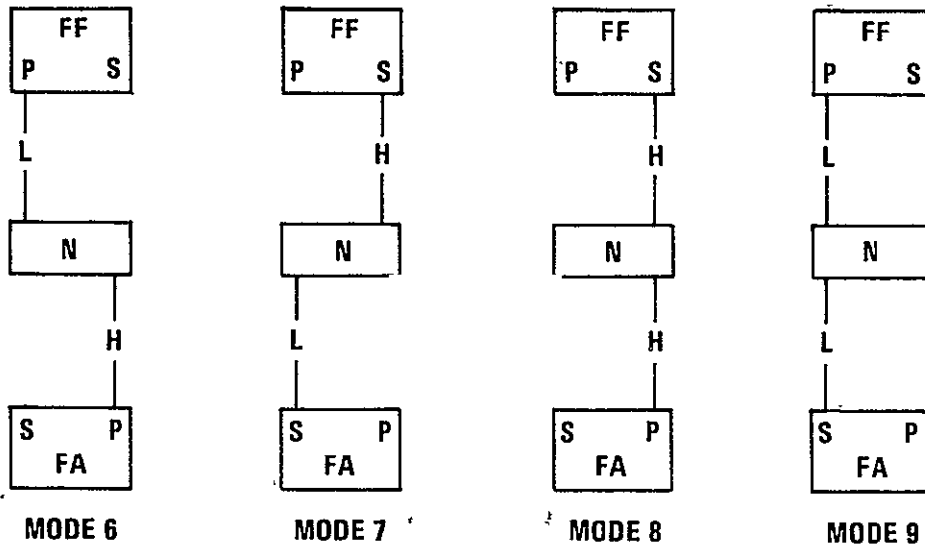

Figure A-6.- Format of the pictorial display.



L - the low-numbered FC bus of the string
H - the high-numbered FC bus of the string
N - the number of GPC controlling the string

Figure A-7.- Visual coding in the pictorial displays of the four possible string modes.

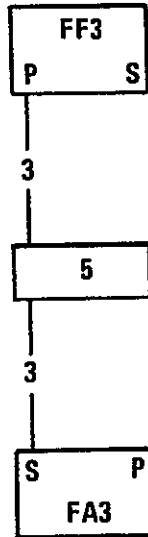

Figure A-8.- Example of pictorial mode indication. String 3 is assigned to GPC 5 and is in mode 9.

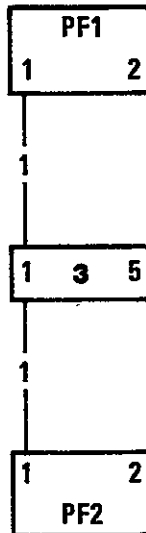

Figure A-9.- Example of pictorial RS indication. The RS consists of GPC's 1, 3, and 5; GPC 3 is the prime GPC; and String 5 is in mode 9.

GPC	BUS	MDM	GPC	BUS	MDM
X	FCL FCH	FFP FFS	X	FCL FCH	FAS FAP
MODE 6					
X	FCL FCH	FFP FFS	X	FCL FCH	FAS FAP
MODE 7					
X	FCL FCH	FFP FFS	X	FCL FCH	FAS FAP
MODE 8					
X	FCL FCH	FFP FFS	X	FCL FCH	FAS FAP
MODE 9					

Figure A-10.- Visual coding in the tabular displays of the string modes.

APPENDIX B

GUIDELINES FOR DESIGNING SCHEMATIC DISPLAYS

A large number of past experiments and investigations have resulted in the establishment of guidelines to be followed in designing schematic displays.

VERBALIZATION

Considerable evidence exists that in a wide variety of tasks requiring the retention of words, concrete words with high imagery values are more easily remembered than abstract words with low imagery values. In addition, Santa (ref. 39) found that name training helped a great deal in visual recognition tasks for shapes. Tversky (ref. 40) required subjects to match combinations of names and faces and found that subjects could control the type of coding used, on the basis of whether they thought visual or verbal information would be needed in the matching task. This experiment also showed that subjects can generate a visual code from a name code. Paivio (ref. 18, p. 127) indicates that recall for imaged words is about the same as for named pictures. Bahrck and Bahrck (ref. 41) suggest that items presented verbally can sometimes be recoded into a visual code and that items presented visually can sometimes be recoded into a verbal code. Paivio (ref. 18, p. 103) wonders whether imagery variables can be best described in terms of visual representations, verbal representations, or a combination of both. He then refers to a paper of his (ref. 42) in which he suggests that visual or highly imagable verbal material may be coded dually in verbal and visual systems that are connected but somewhat independent of each other. Therefore, pictures can be named and words can evoke images. There can be higher performance for items that can be coded into both systems. Paivio goes on to propose (ref. 18, p. 105) that an item could be coded or accessed through the two systems in varying degrees. In reference to coding an item both visually and verbally, Reed (ref. 43, p. 112) states that "An advantage is that if information about each item is stored in both modalities, subjects should have a greater chance of recalling the item. The formation of a visual image from a word and the naming of a visual pattern represent ways of changing the modality of the memory code." There are also many other experiments that seem to support the dual-coding theory and even the proposition made by Paivio (ref. 18, p. 109) that visual and verbal codes can have an additive effect in retention of an item. The verbal codes for the units of the subsystems, of course, already exist in the form of the acronyms and names of those units. The addition of the geometric codes that would appear in the schematic displays would provide the visual coding required for the dual-coding theory to take effect.

Conrad found that for shorter term memory tasks, visual information seems to be translated not only into a verbal form (ref. 44) but actually into an articulatory form (ref. 45). Paivio (ref. 18, pg. 124) indicates that words easily pronounced can be recalled more readily than words difficultly pronounced: It would be advantageous to be able to construct the verbal codes

for the units of the subsystems so that they would be easily pronounceable. However, because the names and acronyms come into existence long before the corresponding cathode-ray-tube (CRT) displays, determining verbal codes for the units of subsystems would probably not be considered to be part of the task involved in designing CRT displays.

Conrad and Hull (ref. 46) showed that acoustic similarity of items to be remembered in a shorter term memory task greatly detracted from performance. Wickelgren (ref. 47) found that acoustic similarity between letters to be remembered in a shorter term memory task detracted from the ability to remember the order of the presentation of the letters. Salzberg, Parks, Kroll, and Parkinson (ref. 48) showed that shadowed letters acoustically similar to a target letter affected only verbally presented letters and only if they appeared within 4 seconds of the presentation of the target letter. Steinheiser (ref. 49) states that "Auditory confusions are very frequent for visually presented letters in a short-term memory task." Nelson and Brooks (ref. 50) found that articulatory similarity of the stimulus words interferes with recall in a verbal shorter term memory paired-associate learning task. Once again, it would be advantageous to be able to construct the verbal codes in a manner that would avoid acoustic similarities. However, any efforts towards this accomplishment would probably take place far in advance of the design of the corresponding CRT displays.

In addition to aiding recall in shorter term memory tasks that a crew-member may have to perform while using the schematic displays, because the names of the units of the subsystems would be used to verbally transmit information related to the subsystem being examined from one crewmember to another and between the spacecraft and the ground (the latter type of transmission being particularly susceptible to noise), the implementation of these features of verbal coding would certainly help in reducing the number of reception errors.

Wickelgren (ref. 47) also found that acoustic similarities of vowels had more effect than acoustic similarities of consonants. This aspect, too, would be advantageous to incorporate into the system of verbal codes. However, it might be considered a fairly trivial point and could be somewhat impractical to implement.

Baddeley, Thomson, and Buchanan (ref. 51) indicate that with a constant number of phonemes, recall is better for words of short temporal duration than for those of long temporal duration. However, implementing this factor into the name and acronyms used in connection with the schematic displays might also be considered fairly trivial and somewhat impractical.

DIMENSIONS

The question that must now be considered is, when designing the schematic displays, should the coding used be unidimensional or multidimensional? Baddeley (ref. 52, p. 355) proposes that multidimensional coding aids discrimination of items and allows redundant coding. Miller (ref. 53) found that

multidimensional coding greatly aided discriminative capacity in recognition tasks. Baddeley (ref. 52, p. 357) suggests that redundant coding - that is, increasing the number of dimensions with which an item is coded - has the advantage that the greater the number of dimensions, the greater the probability that at least one will be available to provide access to that item so that it can be retrieved. Dallett and Wilcox (ref. 35) found that free recall of pictures was accomplished more easily than that of descriptions. It is possible that pictures had features coded in more than one dimension whereas descriptions did not. In the free-recall test, for the pictures, any dimension known could be used to retrieve a feature. In the descriptions, because it was very possible that only one dimension for a feature was ever mentioned, it could be much more difficult to retrieve that feature on the recall test. Goldstein and Chance (ref. 54) propose that good recognition of complex pictures is partly due to the large number of dimensions available with which to tell the difference between one picture and another. This concept that photographs can be remembered so well because many features - including the possibility of a "have seen the photograph before," "have not seen the photograph before" feature for recognition tests - are coded in more than one dimension would certainly help in explaining the very high performance in experiments described earlier, in which the recognition of photographs was required (refs. 2 to 4). However, Kuehn (ref. 55) indicates that adding redundant dimensions to a display can increase the complexity of both the learning procedures for the display and the interpretation procedures for the display. He suggests that when it is sufficient, only one dimension for each feature should be used. For example, on a military display, enemy units can be red and friendly units blue, rather than the respective representations being small red squares and large blue circles. Garner (ref. 56) and Lockheed (ref. 57) propose that there are two different types of redundant coding dimensions, integral and separable. Integral dimensions are difficult to separate from each other. For example, it would be difficult to determine only the hue or only the brightness of a colored chip without noticing the other dimension. Separable dimensions are easy to separate from each other. For example, it would be easy to determine only the angular orientation or only the length of a straight line without noticing the other dimension. They further propose that dimensions may have to be continuous in order to be integral. For example, hue and brightness are continuous dimensions. A dimension consisting of discrete values, such as the set of only two values, TRUE and FALSE, is not a continuous dimension. They also suggest that to obtain increased performance in classification tests by adding redundant dimensions, the dimensions added must be integral. Morton (ref. 58) required subjects to sort packs of 36 cards containing 6 different values, arranged as one 1, two 2's, . . . , six 6's. These were sorted faster than packs in which each card contained a single digit, 1 to 6, and these were sorted faster than packs in which each card contained one to six X's. Although it would seem that a dimension containing only six values, the digits 1 to 6, is a discrete dimension that is not continuous, the cards with X's were not sorted as quickly as the cards wherein the X's were replaced by the appropriate digits. As a possible extension of this type of difference in dimensions, consider presenting the numbers 1 to 9 either by using a unary number system with X as the only symbol, or by using a modification of this system wherein each number, n, would be presented as n n's. For example a 9 would be presented as either XXXXXXXXX or 99999999. A subject viewing 99999999 could easily

use the digit dimension to determine that the number is nine, without counting the nine 9's. However, to use the unary dimension to count the nine 9's without noticing that 9's are being counted would be difficult. It seems, then, that getting a clear handle on the separability of two dimensions, even in an apparently simple situation, can be difficult. In addition, these experiments were classification experiments and it is not clear how the differences between integral and separable redundant dimensions would affect recall tasks.

Regardless of whether redundant dimensions would substantially aid recall of configurations of schematic displays, there are two considerations - in addition to Kuehn's suggestion that redundant dimensions can add too much complexity to a display - that might make it advisable to limit the number of dimensions used to display a feature to a minimum. The first consideration is that there might be many displays and many configurations for each display. Within each of the possible visual dimensions available, there are some limits on the number of different values that can be used. McCormick (ref. 59, p. 111), Loewe (ref. 60, p. 32), and Engel and Granda (ref. 1) all present tables of limitations on the various dimensions that can be used. A composite is presented in table B-1. This table provides a fairly accurate and complete summary of the dimensions usually available and of the limits on the number of levels of each dimension that can be used.

Not all the dimensions presented in table B-1 are available for use within the Space Shuttle Orbiter multifunction CRT display system (MCDS). For example, there are no color or photographic capabilities. Because there are limits on the number of levels that can be used in each dimension and because there might be many displays and many configurations for each display, it might be advisable to display a feature with use of the minimum number of dimensions because the use of highly redundant coding might result in the necessity to use the same levels of the same dimensions in a large number of displays and in a manner that could cause interference when the configuration of a particular display was recalled. Another extremely important consideration - especially in regard to designing schematic displays for the Orbiter MCDS - is that adding redundant geometric coding dimensions will greatly increase the amount of software required to generate the displays.

Kuehn (ref. 55) suggests that one coding dimension should not be used for a variety of categories. For example, on a military display, do not use red for enemy bombers, yellow for enemy fighters, blue for friendly bombers, and green for friendly fighters. Use two coding dimensions - red for enemies, blue for friends, circles for bombers, and squares for fighters.

Another suggestion is that coding levels within a dimension should not be interchanged between two features. For example, on one display do not have general-purpose computers (GPC's) represented as squares and multiplexers/demultiplexers (MDM's) as circles, and on another display have GPC's as circles and MDM's as squares.

To reduce the amount of possible interference, an attempt should be made to separate the use of the same coding dimensions and the same levels within each coding dimension as far as possible in the set of schematic displays.

If possible, an attempt should be made to use the same code for the same feature in all the schematic displays. For example, if it has been decided that GPC's should be displayed as squares, then they should be presented as squares in all the displays, if it is possible.

Kuehn (ref. 55) states that "Certain three-dimensional events may provide important qualitative information by a stereoscopic presentation, but there appears to be no quantitative advantage over the use of two-dimensional parametric equivalents." This statement, together with the very high software cost associated with three-dimensional computer generated displays, suggests that for the purpose of providing subsystems management information, three-dimensional coding should not be used.

SEMANTICS

Glanzer and Meinzer (ref. 61) propose that in free recall, it would be better to organize the items to be recalled semantically than to use rote rehearsal. Baddeley (ref. 52, p. 117) indicates that Sachs (refs. 62 and 63), Wanner,⁷ and Johnson-Laird and Stevenson (ref. 64) showed that when text is being read, most syntactic information is quickly forgotten and most semantic information is remembered for a long time. Baddeley (ref. 52, p. 273) also indicates that when any list of items to memorize is given, subjects will always try to develop some strategy for finding relationships between the items. Bower (ref. 65) indicates that in longer term memory tasks, subjects try to group material into perceptual groups. These become functional recall units. Recall suffers if subjects have to regroup familiar material. Bower, Clark, Lesgold, and Winzenz (ref. 66) also indicate that free recall of word lists is greatly improved if the words can be organized and grouped semantically. Kintsch (ref. 67, p. 362) indicates that there should be relationships between the items to be recalled in order to aid generation. This helps explain why organization is much more important for recall than it is for recognition. Oldfield and Wingfield (ref. 68) found that the speed and accuracy of determining the names of pictures and objects increase as the names of pictures and objects increase in familiarity. Brown (ref. 69, p. 13) suggests that there may be relational attribute codes that can link two words together. Reed (ref. 43, p. 130) indicates that Frost⁸ found that if semantic coding is possible for recalling shapes, then after a 15-minute retention interval, subjects will use both visual and semantic codes to recall the shapes. However, the subjects had to be led to believe that they would be asked to perform a recognition task, a requirement that would explain the visual coding. In recall and recognition experiments wherein subjects were tested on what

⁷Wanner, H. E.: On Remembering, Forgetting, and Understanding Sentences: A Study of the Deep Structure Hypothesis. Unpublished doctoral dissertation, Harvard Univ., 1968.

⁸Frost, N.: Contributions of Visual and Semantic Codes to Memory for Pictures. Unpublished Ph. D. dissertation, Univ. of Oregon, 1971.

they expected, the recall group used almost only semantic coding, whereas the recognition group used visual and semantic coding. Maier, Thurber, and Janzen (ref. 70) found that in a free-recall experiment wherein 24 words were learned while shown in a random order - each word being flashed on a card for 1 second and testing taking place after 4, 8, and 12 trials - there was a considerable amount of semantic clustering of words. For example, weather words like "hot" and "damp" and food words like "crackers" and "milk" clustered. The clustering became more refined as the trials progressed. Dale and Baddeley (ref. 71) suggest that for longer term memory, in paired-associate learning of words, semantic similarity has an adverse effect but acoustic similarity has no effect. Baddeley (ref. 72) showed, using visually presented words, that shorter term memory seems to mostly use acoustic coding rather than visual or semantic coding. However, he did indicate that there was some evidence for a small amount of semantic coding. Baddeley (ref. 52, p. 117) also proposes that acoustic similarity is most effective in shorter term memory tasks whereas semantic similarity is most effective in longer term memory tasks. Baddeley goes on (ref. 52, p. 118) to suggest that although the evidence is not strong, it is possible that there also is some acoustic coding in longer term memory tasks and some semantic coding in shorter term memory tasks. Baddeley continues (ref. 52, p. 120) and proposes that acoustic coding is mostly used in shorter term memory tasks because the items to be remembered are often meaningless and presented rapidly. When it is possible, semantic coding begins immediately. Acoustic coding may be used in longer term memory only when no semantic coding is possible. Baddeley also indicates that items coded semantically will not be easily forgotten and that semantic coding of an item may indicate that it has been stored in longer term memory.

There would, of course, be a great deal of semantic significance given to all the units of a subsystem. However, the degree of semantic coding that exists for the various aspects of a unit of a subsystem might be determined, to a large extent, by the visual representations that have been chosen for those aspects of the unit. This, however, really falls under the classification of visual coding, which will be discussed in detail in the next section.

It seems then, that semantics are a very important consideration in designing the displays. However, defining semantics of an item as the meaning of that item may be too general a definition to use when the displays are being designed. Because one of the major objectives of using schematic displays is to provide a visual conception of the subsystems, it is important to consider one of the definitions of semantics to mean the information about an aspect of a subsystem and the relationships between that aspect and other aspects of the various subsystems that can be presented visually to the operator.

VISUALIZATION

Paivio (ref. 18, p. 103) indicates that pictures or objects are easiest to image, concrete words or sentences next, and abstract verbal materials the most difficult. He continues (ref. 18, p. 108) and proposes that imagery mnemonics can aid recall and recognition. Begg (ref. 29) showed that concreteness of words greatly aids free recall of adjective-noun pairs. He suggests

that "A concrete phrase provides a unitary representation from which both words can be retrieved. Presentation of one word from the phrase as a retrieval cue further enhances recall because it reintegrates the entire image." Paivio (ref. 18, p. 117) indicates that recall of imaged words was approximately 100 percent better than for pronounced words. He also suggests (ref. 18, p. 121) that recall seems to be related to the verbalization of pictures and the imagability of words. He continues (ref. 18, p. 122) and proposes that, as would be expected, imagery is most effective in tasks where imagery is necessary. For example, for a task in which a subject has to draw a picture related to the word presented, imagery is high. If a subject is to pronounce a list of words as rapidly as possible, imagery is low. Paivio and Csapo (ref. 30) found that sequential memory for pictures presented too fast to label is not as good as for words. However, this is for immediate recall. For learning serial material over many trials, at a lower rate, concreteness can aid recall. Paivio (ref. 34) indicates that pairs are easier to learn when the context facilitates the construction of good conceptual units. Concrete nouns are freely recalled more easily than abstract nouns, and high-imagery nouns more easily than low-imagery nouns. In addition, Paivio proposes that better recalled, vivid nouns become organized to a greater extent than less vivid nouns and that this organization facilitates the grouping of words to form higher order memory units. Parks, Kroll, Salzberg, and Parkinson (ref. 73) indicate that incentive for using a visual code can be important. When one is faced with the possibility of acoustic confusions or verbal interference, it is possible to maintain a visual code for as long as 8 seconds. It is conceivable that under certain circumstances, a crewmember using the schematic displays might encounter verbal interference that could disrupt mental processing. The basic visual nature of the displays would help in minimizing the effect of the verbal interference. Yarmey and Ure (ref. 19) found that concrete nouns are recalled better than abstract nouns. They also suggest that for recall tasks, concreteness is more important as a stimulus than as a response. When the schematic displays are used, the various features of the displays could be utilized as either stimuli or responses. Here too, the visual nature of schematic displays would be advantageous. Yarmey and O'Neill (ref. 21) indicate that for longer term memory tasks of several minutes, high imagery and specificity of nouns aid recall in paired-associate learning. Yuille and Paivio (ref. 25) indicate that for longer term memory tasks of several minutes, for learning paired-associate nouns, imagery aids recall when either or both of the nouns are concrete. Epstein, Rock, and Zuckerman (ref. 74) also suggest that imagery of items can aid learning. Paivio (ref. 36) tested paired-associate learning for all four possible combinations of concrete and abstract nouns as stimuli and responses and obtained the following results.

<u>Stimulus</u>	<u>Response</u>	
	<u>Concrete</u>	<u>Abstract</u>
Concrete	11.41	10.01
Abstract	7.36	6.05

The values are the number of correct responses out of 16 pairs. These results support Yarmey and Ure's proposition that the concreteness of items has a greater effect if the concrete items are the stimuli rather than the responses. All this evidence that the imagery of items greatly aids recall adds to the explanation of why photographs can be remembered so well, as shown in the experiments done by Shepard (ref. 2), Nickerson (ref. 3), and Conezio and Haber (ref. 4). Nickerson indicates that the photographs used were meaningful pictures, and he proposes that the performance for random fields of dots would probably be much lower. There would be few doubts that for meaningful photographs, semantics and imagery would be exceptionally high.

Baddeley (ref. 52, p. 232) proposes that imagery processing can be interfered with but that the basic semantic characteristics of words cannot easily be interfered with. Hollenberg (ref. 28) found that high-imagery subjects were better able to learn the nonsense syllable names of objects than low-imagery subjects. Imagery ability was determined by a spatial manipulation test. Paivio (ref. 18, p. 111) suggests that "Images are uniquely specialized for spatial organization and integration of stimulus information." Schematic displays might represent a subsystem such that the subsystem could be imaged as a hierarchy in which the spatial location, in the hierarchy, of an aspect of the subsystem would be very important in determining the relationships between that aspect and other aspects of the subsystem. Brown (ref. 69, p. 12) suggests that several concepts can be related together simultaneously in an image. Paivio (ref. 18, p. 112) indicates that imagery should be used to form integrated images of items to be remembered, rather than separate images of the items. He also suggests that retrieval cues and items to be remembered should be integrated into an image during input. Begg (ref. 75) showed that cued recall of nouns is aided more when the nouns are imaged as an integrated image than when they are imaged separately. Bower and Winzenz (ref. 5) found that semantic and visual processing in paired-associate learning greatly facilitates recall. For recall under both shorter term (approximately 1 minute) and longer term conditions, interactive imagery was superior to generation of sentences relating the two words together. The latter was superior to reading sentences, which was superior to using rote repetition of the word pairs. Schnorr and Atkinson (ref. 24) found that in paired-associate recall in which retention was required for several minutes, instructions to form a mental relating image of a word pair aided subjects in recall. Begg and Robertson (ref. 76) found that integrated imagery also aids retention in longer term memory tasks of several days. Peterson and Murray (ref. 27) also suggest that interactive imagery can aid the recall of nouns in paired-associate learning. Bower (ref. 23) proposes that mental imagery is superior in paired-associate learning to rote rehearsal either because it increases the reliability

of stimulus encoding or because it increases relational associations between the items produced by the imagery.

It is apparent that for recall tasks, imagery - and, in particular, interactive imagery - of items is very important.

Imagery of subsystem aspects is implied by the pictorial aspects and nature of schematic displays. However, there are many degrees of imagery that displays could suggest. For example, a photographic display of the speedbrake would certainly facilitate imagery of the speedbrake. However, photographic displays are very difficult and expensive to implement for computer-controlled CRT displays. In addition, a photographic display might not be the most efficient interface for informing a crewmember as to the precise angle of separation of the two halves of the speedbrake. On the other hand, although Seymour (ref. 77) proposes that it might be easier to identify familiar shapes such as circles and squares than unfamiliar shapes such as ellipses and oblongs, the speedbrake might be better represented by a simple geometric figure approximating its real shape, such as a trapezoid, rather than by a geometric figure very different from its real shape, such as a circle. When representations for items in the subsystem are designed, if possible, simple geometric shapes should be chosen that approximate the real shapes of the items. The "if possible" is very significant because many of the aspects of a subsystem that have to be displayed, such as which GPC's are currently in a redundant set, do not correspond to any physical objects in the subsystem and because many items, such as the primary and secondary ports of the MDM's, are not easily imagable.

Royer (ref. 78) found that when sets of simple shapes (two to four lines each, eight shapes per set) were learned, it was easier to recall correctly the sets in which each shape was unique, and hardest to recall the sets in which figures were used more than once, only in different rotational orientations and mirror images. This concept can be applied in the design of the schematic displays. An attempt should be made to avoid designing similar geometric figures for different aspects of a subsystem.

Loftus and Palmer (ref. 79) showed that recall of visual material can be greatly distorted by verbal cues. Carmichael, Hogan, and Walter (ref. 80) found that the labels used for simple geometric figures caused subjects to distort the figures, when recalling them by drawing the figures, towards the labels used as cues. Hanawalt and Demarest (ref. 81) showed that even unlabeled figures can be recalled in a distorted manner if the cues used for recalling the figures suggest distortions. These experiments suggest that the geometric figures representing various aspects of the subsystem could greatly affect an operator's conception of the subsystem. For example, assume that, in the schematic displays, GPC's are represented by rectangles. If a crewmember is not very familiar with the actual physical appearance of the GPC's, then rather than having the rectangles evoke images of real GPC's, that crewmember might eventually come to think of a GPC as basically a rectangle with certain characteristics rather than the rectangular solid with two handles, five connectors, and various indicators that it really is.

THE GROUPING OF INFORMATION

Bower (ref. 82) proposes that it is possible that in recalling line drawings, it is easier to recall them if they can be recalled as unitary figures that can be continuously drawn than if they must be recalled as a sequence or set of individual lines. Baddeley (ref. 52, p. 266) indicates that Gestalt psychologists felt that "Items tend to be perceived as patterns; the observer appears to use such factors as similarity, proximity, and continuity to organize a cluster of items into a unified whole." As mentioned earlier, Nickerson (ref. 3) proposes that performance for identifying random fields of dots would probably be much lower than the high performance levels attained in the experiments wherein photographs were used. Royer (ref. 83) found that in sorting cards with dot figures on them, sets with good or simple figures were easier to sort than cards with apparently random fields of dots on them. Reed (ref. 43, p. 126) proposes that in viewing patterns, if they have no names, then subjects using a verbal code would have to remember verbal descriptions of the patterns. Reed (ref. 43, p. 124) suggests that although identification of familiar types of pictures over long delays is very good, identification of complex, unfamiliar pictorial stimuli, when homogeneous arrays are presented, is not very good. All of this implies that the visual structure of the schematic displays representing the configurations of the subsystem is very important. The structure of each display should approach a single, unified pattern that can be easily identified and recalled.

SPATIAL ORGANIZATION

Engel and Granda (ref. 1) suggest that the designers of CRT displays, in general, should "Standardize organization of displayed fields within a specific screen format, and do not change. For example, functional areas should remain in the same relative display location on all frames." This concept can be modified to suggest that the geometric symbols that represent the units of a subsystem should always appear in the same locations relative to each other, throughout all the displays in the set of displays. For example, consider an analogy. Regardless of what map is being viewed in an atlas of the United States, if New York and Philadelphia appear on the map, New York will always be north of Philadelphia. Changing maps will not change their locations relative to each other. This organization would help in establishing the image of the entire subsystem because all the units of the subsystem would always be in the same locations relative to each other and a crewmember would not have to change the basic structure of the image on the basis of what display was being viewed.

DISPLAY/CONTROL COMPATIBILITY

McCormick (ref. 59, p. 288) suggests that the spatial relationships between displays and controls should be as close as possible. For example, if one is given 100 lights and 100 corresponding buttons to push when the appropriate light goes on, it would be much better to have a 20x10 matrix where a row of lights has the corresponding row of buttons directly under it than to have two 10x10 matrices, one of lights and the other of the corresponding buttons. He goes on (ref. 59, p. 289) to describe an experiment performed by Chapanis and Lindenbaum (ref. 84) in which subjects were presented with these four different stove burner/control arrangements.

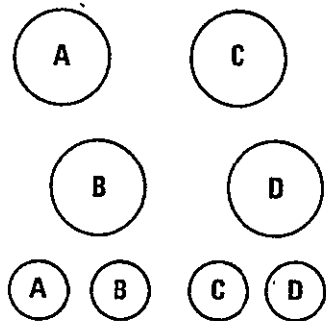

Design 1

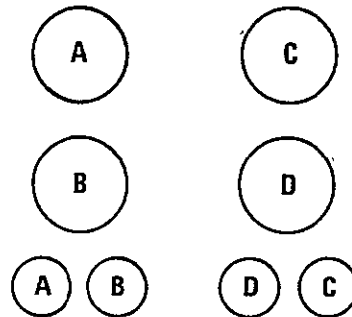

Design 2

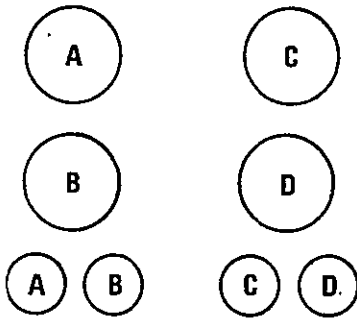

Design 3

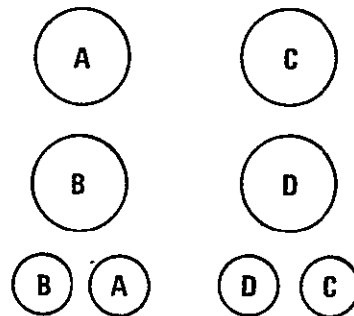

Design 4

Out of 1200 trials, there were no errors made in using design 1, 76 were made in using design 2, 116 with design 3, and 129 with design 4. This experiment shows that performance is much better if the controls correspond spatially to the displays. If an aspect of a subsystem to be presented on a display relates to a set of controls or displays other than the set of schematic displays, then the presentation of that aspect on the schematic display should correspond to the spatial location of the controls or displays related to that aspect as closely as possible. As an example, consider the initial program load (IPL) pushbuttons for the GPC's, which are arranged in a row of five. If an aspect of the GPC IPL's was to be represented on a schematic display, then that aspect should have a spatial orientation such that the IPL's for the five GPC's are presented in a row. Obtaining good spatial display/control compatibility could aid crewmembers in forming an image of the DPS that includes a representation of the controls as they actually appear in the Space Shuttle Orbiter. It could also aid crewmembers in using the schematic displays to obtain information to assist them in operating the controls.

TABLE B-1.- LIMITATIONS ON THE VARIOUS CODING DIMENSIONS NORMALLY AVAILABLE

Code	Approximate no. of levels	Evaluation	Comments
Color	11	Good	Little space required; location time short; attention getting; problems with color-defective people; can be affected by other lighting
Numerals and letters	Unlimited for combinations of symbols	Good	Little space required if contrast and resolution are good; location time is longer than for colors
Geometric shapes	15	Good	Little space required if resolution is good; certain shapes easily recognized
Size	5	Fair	Requires considerable space; location time longer than for color or shapes
Length of line	4	Fair	Will clutter display with many signals
Brightness	3 to 4	Poor	Poor contrast will reduce visibility of weaker signals
Flash rate	3 to 5	Poor	Interacts poorly with other codes; this can be distracting and fatiguing; useful in special situations, for example, as a warning
Orientation	12 to 24	Good	About 2% errors with 24 levels; use fewer levels for more accuracy; practice and knowledge of results improve use
Number	5	Fair	Requires considerable space; can clutter display; can result in counting for display of numbers 4 and 5

TABLE B-1.- Concluded

Code	Approximate no. of levels	Evaluation	Comments
Photographic displays	1000	Good	Excellent recall and recognition characteristics; illustrates situation well; very difficult and expensive to implement for computer-controlled CRT displays
Position	4 to 9	Fair	Requires considerable space
Depth	3 to 4	Fair	Only applicable in special situations; easily confused when viewed on two-dimensional display; extremely expensive in terms of software for computer-controlled CRT systems
Line type	4	Good	Little space required; wide range of applications; can be confusing if used too much
Line width	3	Good	Little space required; wide range of applications; can be confusing if used too much
Crosshatching	4	Good	Can require moderate space; crosshatched area should not contain any labels

APPENDIX C

ACRONYMS AND ABBREVIATIONS

AC	alternating current
ACTV	activation
ADDR	address
adj	adjust
AL	airlock
BITE	built-in test equipment
BOT	beginning of tape
BRIT	brightness
BU COMP	backup computer
C/B	COMPUTER/BUS key
CDMS	command and data management subsystem
CDMS MANG	CDMS management display
CH	channel
co	contingency operation
con	control
CONN	Connect
CPU	central processing unit
CRT	cathode ray tube
DACT	deactivation
DC	direct current
dcov	direct control over via
DDU	digital display unit
DEU	display electronics unit
DISDUR	display duration

DISP	DISPLAY key
dlb	directly linked by
dltb	directly linked together by
DMA-IOCU	direct memory access input/output control unit
DPS	data processing subsystem
ENA	enable
EOT	end of tape
ERAS	erase
ETR	ENTER key
EXP COMP	experiments computer
EXPIO	experiments input/output unit
EXP RAU	experiments remote aquisition unit
FA1-FA4	flight-aft multiplexer/demultiplexers 1-4
FC1-FC8	flight-critical data buses 1-8
FCW	format control word
FF	fast forward
FF1-FF4	flight-forward multiplexer/demultiplexers 1-4
FR	fast reverse
GPC	general-purpose computer
HRDR	high-rate data recorder
HRM	high-rate multiplexer
hw	half word
IC	intercom
ind	individual
I/O	input/output
IPL	initial program load

KB	keyboard
KBD	keyboard/digital display unit
KU BAND SIG PRO	Ku-band signal processor
lim	limit
MAX	maximum
MCDS	multifunction CRT display system
MDM	multiplexer/demultiplexer
MEM	memory
MIN	minimum
MMU	mass memory unit
MNTR	monitoring and controlling
MOTR	motor
MSTR	master
MTU	master timing unit
MTUI	master timing unit interface
OPS	operational sequence key
P	primary
PCMMU	pulse code modulation master unit
PF1, PF2	payload multiplexer/demultiplexer 1 and 2
PHOS	phosphor
pic	pictorial
PIC	picture
PL1, PL2	payload data buses 1 and 2
PLGPC	payload general-purpose computer
PLRC	payload recorder
PRI	primary

PRO	PROCEED key
PWR	power
PWR NET	power network
RAAB	remote amplifier and advisory box
RCRD	record
REPL	replay
RS	redundant set
RSET	reset
RTC	remote text command
S	secondary
SECV	secondary voltage
SPEC	SPEC key
SPWR	secondary power supply
SS COMP	subsystems computer
SSIO	subsystems input/output unit
SS RAU	subsystems remote acquisition unit
tab	tabular
TEMP	temperature
TFI	tape footage indicator
V	volts
VD	voice digitizer
VOLT	voltage
VPARM	variable parameter

REFERENCES

1. Engel, Stephen E.; and Granda, Richard E.: Guidelines for Man/Display Interfaces. TR 00.2720, I.B.M., 1975.
2. Shepard, Roger N.: Recognition Memory for Words, Sentences and Pictures. *J. Verbal Learning and Verbal Behavior*, vol. 6, no. 1, 1967, pp. 156-167.
3. Nickerson, Raymond S.: Short-Term Memory for Complex Meaningful Visual Configurations: A Demonstration of Capacity. *Canadian J. Psych.*, vol. 19, no. 2, 1965, pp. 155-160.
4. Standing, Lionel; Conezio, Jerry; and Haber, Ralph N.: Perception and Memory for Pictures: Single-Trial Learning of 2560 Visual Stimuli. *Psychonomic Sci.*, vol. 19, no. 2, 1970, pp. 73-74.
5. Bower, Gordon H.; and Winzenz, David: Comparison of Associative Learning Strategies. *Psychonomic Sci.*, vol. 20, no. 2, 1970, pp. 119-120.
6. Standing, Lionel; and Smith, Philip: Verbal-Pictorial Transformations in Recognition Memory. *Canadian J. Psych.*, vol. 29, no. 4, 1975, pp. 316-326.
7. Paivio, Allan; Rogers, T. B.; and Smythe, Padric C.: Why Are Pictures Easier to Recall Than Words? *Psychonomic Sci.*, vol. 11, no. 4, 1968, pp. 137-138.
8. Bevan, W.; and Steger, J. A.: Free Recall and Abstractness of Stimuli. *Science*, vol. 172, 1971, pp. 597-599.
9. Paivio, Allan; and Csapo, Kalman: Picture Superiority in Free Recall: Imagery or Dual Coding? *Cognitive Psych.*, vol. 5, no. 2, 1973, pp. 176-206.
10. Sampson, Jeffrey R.: Free Recall of Verbal and Non-Verbal Stimuli. *Quart. J. Exp. Psych.*, vol. 22, no. 2, 1970, pp. 215-221.
11. Scott, Keith G.: Clustering With Perceptual and Symbolic Stimuli in Free Recall. *J. Verbal Learning and Verbal Behavior*, vol. 6, no. 6, 1967, pp. 864-866.
12. Davies, G. M.: Recognition Memory for Pictured and Named Objects. *J. Exp. Child Psych.*, vol. 7, no. 3, 1969, pp. 448-458.
13. Gorman, Aloysia M.: Recognition Memory for Nouns as a Function of Abstractness and Frequency. *J. Exp. Psych.*, vol. 61, 1961, pp. 23-29.
14. Jenkins, Joseph R.; Neale, Daniel C.; and Deno, Stanley L.: Differential Memory for Pictures and Word Stimuli. *J. Ed. Psych.*, vol. 58, no. 5, 1967, pp. 303-307.

15. Gupton, T.; and Frincke, G.: Imagery, Mediational Instruction, and Noun Position in Free Recall of Noun-Verb Pairs. *J. Exp. Psych.*, vol. 86, no. 3, 1970, pp. 461-462.
16. Mueller, John H.; and Jablonski, Eugene M.: Instructions, Noun Imagery, and Priority in Free Recall. *Psychological Reports*, vol. 27, no. 2, 1970, pp. 559-566.
17. Groninger, L. D.; Bell, B.; Cymer, W.; and Wess, B.: Storage Aspects of Nouns Presented Under Imagery and Acoustic Coding Instructions. *J. Exp. Psych.*, vol. 95, no. 1, 1972, pp. 195-201.
18. Paivio, Allan: Imagery in Recall and Recognition. *Recall and Recognition*, J. Brown, ed., Wiley (Bath, England), 1976, pp. 103-129.
19. Yarmey, A. D.; and Ure, G.: Incidental Learning, Noun Imagery-Concreteness and Direction of Associations in Paired-Associate Learning. *Canadian J. Psych.*, vol. 25, no. 2, 1971, pp. 91-102.
20. Paivio, A.; and Yarmey, A. D.: Pictures Versus Words as Stimuli and Responses in Paired-Associate Learning. *Psychonomic Sci.*, vol. 40, no. 5, 1966, pp. 235-236.
21. Yarmey, A. Daniel; and O'Neill, Brian J.: S-R and R-S Paired-Associate Learning as a Function of Concreteness, Imagery, Specificity, and Association Value. *J. Psych.*, vol. 71, no. 1, 1969, pp. 95-109.
22. Paivio, Allan; and Rowe, Edward J.: Noun Imagery, Frequency and Meaningfulness in Verbal Discrimination. *J. Exp. Psych.*, vol. 85, no. 2, 1970, pp. 264-269.
23. Bower, Gordon H.: Imagery as a Relational Organizer in Associative Learning. *J. Verbal Learning and Verbal Behavior*, vol. 9, no. 5, 1970, pp. 529-533.
24. Schnorr, J. A.; and Atkinson, R. C.: Repetition Versus Imagery Instructions in the Short- and Long-Term Retention of Paired-Associates. *Psychonomic Sci.*, vol. 15, no. 4, 1969, pp. 183-184.
25. Yuille, John C.; and Paivio, Allan: Imagery and Verbal Mediation Instructions, in Paired-Associate Learning. *J. Exp. Psych.*, vol. 78, no. 3, 1968, pp. 436-441.
26. Paivio, Allan; and Foth, Dennis: Imaginal and Verbal Mediators and Noun Concreteness in Paired-Associate Learning: the Elusive Interaction. *J. Verbal Learning and Verbal Behavior*, vol. 9, no. 4, 1970, pp. 384-390.
27. Peterson, M. J.; and Murray, A.: Enhancement of Items and Associations. *J. Exp. Psych.*, vol. 101, no. 2, 1973, pp. 82-89.

28. Hollenberg, C. K.: Functions of Visual Imagery in the Learning and Concept Formation of Children. *Child Development*, vol. 41, no. 4, 1970, pp. 1003-1015.
29. Begg, Ian: Recall of Meaningful Phrases. *J. Verbal Learning and Verbal Behavior*, vol. 11, no. 4, 1972, pp. 431-439.
30. Paivio, Allan; and Csapo, 'Kali: Concrete-Image and Verbal Memory Codes. *J. Exp. Psych.*, vol. 80, no. 2, 1969, pp. 279-285.
31. Nelson, Douglas L.; Brooks, David H.; and Borden, Richard C.: Sequential Memory for Pictures and the Role of the Verbal System. *J. Exp. Psych.*, vol. 101, no. 2, 1973, pp. 242-245.
32. Snodgrass, Jean. G.; and Antone, George: Parallel vs. Sequential Processing of Pictures and Words. *J. Exp. Psych.*, vol. 103, no. 1, 1974, pp. 139-144.
33. Paivio, Allan; Yuille, John C.; and Rogers, T. B.: Noun Imagery and Meaningfulness in Free and Serial Recall. *J. Exp. Psych.*, vol. 79, no. 3, 1969, pp. 509-514.
34. Paivio, Allan: Mental Imagery in Associative Learning and Memory. *Psych. Rev.*, vol. 76, no. 3, 1969, 241-263.
35. Dallett, K.; and Wilcox, S. G.: Remembering Pictures vs. Remembering Descriptions. *Psychonomic Sci.*, vol. 11, no. 4, 1968, pp. 139-140.
36. Paivio, Allan: Abstractness, Imagery, and Meaningfulness in Paired-Associate Learning. *J. Verbal Learning and Verbal Behavior*, vol. 4, no. 1, 1965, pp. 32-38.
37. Sutherland, Ivan E.: Computer Inputs and Outputs. *Scientific American*, vol. 215, no. 3, 1966, pp. 86-96.
38. Martin, James: Design of Man-Computer Dialogues. Prentice-Hall, (Englewood Cliffs, N. J.), 1973.
39. Santa, J. L.: The Effects of Verbal Coding on Recognition Memory. Ph. D. Dissertation, Purdue Univ., 1970.
40. Tversky, B.: Pictorial and Verbal Encoding in A Short-Term Memory Task. *Perception and Psychophysics*, vol. 6, no. 4, 1969, pp. 225-233.
41. Bahrick, H. P.; and Bahrick, P.: Independence of Verbal and Visual Codes of the Same Stimuli. *J. Exp. Psych.*, vol. 91, no. 2, 1971, pp. 344-346.
42. Paivio, Allan: A Theoretical Analysis of the Significance of Imagery in Learning and Memory. *The Function and Nature of Imagery*, P. Sheehan, ed., Academic Press (New York), 1972, pp. 253-273.

43. Reed, Steven K.: *Psychological Processes in Pattern Recognition*. Academic Press (New York), 1973.
44. Conrad, R.: *Acoustic Confusion in Immediate Memory*. *British J. Psych.*, vol. 55, no. 1, 1964, pp. 75-84.
45. Conrad, R.: *Short-Term Memory Processes in the Deaf*. *British J. Psych.*, vol. 61, no. 2, 1970, pp. 179-195.
46. Conrad, R.; and Hull, A. J.: *Information, Acoustic Confusion and Memory Span*. *British J. Psych.*, vol. 55, no. 4, 1964, pp. 429-432.
47. Wickelgren, Wayne A.: *Acoustic Similarity and Intrusion Errors in Short-Term Memory*. *J. Exp. Psych.*, vol. 70, no. 2, 1965, pp. 102-108.
48. Salzberg, P. M.; Parks, T. E.; Kroll, N. E.; and Parkinson, S. R.: *Retroactive Effects of Phonemic Similarity on Short-Term Recall of Visual and Auditory Stimuli*. *J. Exp. Psych.*, vol. 91, 1971, pp. 43-46.
49. Steinheiser, F. H., Jr.: *Phonemic Distinctive Feature Encoding From Visual Information Storage*. Ph. D. Dissertation, Univ. of Cincinnati, 1970.
50. Nelson, Douglas L.; and Brooks, David H.: *Functional Independence of Pictures and Their Verbal Memory Codes*. *J. Exp. Psych.*, vol. 98, no. 1, 1973, pp. 44-48.
51. Baddeley, Allan D.; Thomson, Neil; and Buchanan, Mary: *Word Length and the Structure of Short-Term Memory*. *J. Verbal Learning and Verbal Behavior*, vol. 14, no. 6, 1975, pp. 575-589.
52. Baddeley, Alan D.: *The Psychology of Memory*. Basic Books (New York), 1976.
53. Miller, G. A.: *The Magical Number Seven, Plus or Minus Two: Some Limits of our Capacity for Processing Information*. *Psychological Rev.*, vol. 63, 1956, pp. 81-97.
54. Goldstein, A. G.; and Chance, J. E.: *Recognition of Complex Visual Stimuli*. *Perception and Psychophysics*, vol. 9, no. 2-B, 1971, pp. 237-241.
55. Kuehn, R. L.: *Display Requirements Assessment for Command and Control Systems*. *J. Soc. for Info. Display*, vol. 3, 1966, pp. 43-46.
56. Garner, W. R.: *The Stimulus in Information Processing*. *American Psychologist*, vol. 25, no. 4, 1970, pp. 350-358.
57. Lockheed, G. R.: *Effects of Dimensional Redundancy on Visual Discrimination*. *J. Exp. Psych.*, vol. 72, no. 1, 1966, pp. 95-104.

58. Morton, John: The Use of Correlated Stimulus Information in Card Sorting. *Perception and Psychophysics*, vol. 5, no. 6, 1969, pp. 374-376.
59. McCormick, Ernest J.: *Human Factors Engineering*. Second ed. McGraw-Hill (New York), 1964.
60. Loewe, Richard T.: System Design, Coding, Formats, and Programming. *Display Systems Engineering*, H. R. Luxenberg and R. L. Kuehn, eds., McGraw-Hill, 1968, pp. 24-69.
61. Glanzer, M.; and Meinzer, A.: The Effects of Intralist Activity on Free Recall. *J. Verbal Learning and Verbal Behavior*, vol. 6, no. 6, 1967, pp. 928-935.
62. Sachs, Jacqueline D.: Recognition Memory for Syntactic and Semantic Aspects of Connected Discourse. *Perception and Psychophysics*, vol. 2, no. 1, 1967, pp. 437-442.
63. Sachs, Jacqueline: Memory in Reading and Listening to Discourse. *Memory and Cognition*, vol. 2, no. 1-A, 1974, pp. 95-100.
64. Johnson-Laird, P. N.; and Stevenson, Rosemary: Memory for Syntax. *Nature*, vol. 227, 1970, p. 412.
65. Bower, Gordon H.: Organizational Factors in Memory. *Cognitive Psych.*, vol. 1, 1970, pp. 18-46.
66. Bower, G. H.; Clark, M. C.; Lesgold, A. M.; and Winzenz, D.: Hierarchical Retrieval Schemes in Recall of Categorized Word Lists. *J. Verbal Learning and Verbal Behavior*, vol. 8, no. 2, 1969, pp. 323-343.
67. Kintsch, W.: *Learning, Memory and Conceptual Processes*. John Wiley and Sons (New York), 1970.
68. Oldfield, R. C.; and Wingfield, A.: Response Latencies in Naming Objects. *Quart. J. Exp. Psych.*, vol. 17, no. 4, 1965, pp. 273-281.
69. Brown, John: An Analysis of Recognition and Recall and of Problems in Their Comparison. *Recall and Recognition*, J. Brown, ed., Wiley (Bath, England), 1976, pp. 1-35.
70. Maier, N. R. F.; Thurber, J. A.; and Janzen, J. C.: The Selection Process in Recall and in Problem Solving Situations, *Problem Solving and Creativity, In Individuals and Groups*, N. R. F. Maier, ed., Wadsworth (Belmont, Calif.), 1970, pp. 62-81.
71. Dale, H. C.; and Baddeley, A. D.: Acoustic Similarity in Long-Term Paired-Associate Learning. *Psychonomic Sci.*, vol. 16, no. 4, 1969, pp. 209-211.

72. Baddeley, A. D.: Short-Term Memory for Word Sequences as a Function of Acoustic, Semantic and Formal Similarity. *Quart. J. Exp. Psych.*, vol. 18, no. 4, 1966, pp. 362-365.
73. Parks, T. E.; Kroll, N. E. A.; Salzberg, P. M.; and Parkinson, S. R.: Persistence of Visual Memory as Indicated by Decision Time in a Matching Task. *J. Exp. Psych.*, vol. 92, no. 3, 1972, pp. 437-438.
74. Epstein, William; Rock, Irwin; and Zuckerman, Carl B.: Meaning and Familiarity in Associative Learning. *Psychological Monographs*, vol. 74, no. 4, 1960, p. 22.
75. Begg, Ian: Imagery and Integration in the Recall of Words. *Canadian J. Psych.*, vol. 27, no. 2, 1973, pp. 159-167.
76. Begg, Ian; and Robertson, Richard: Imagery and Long-Term Retention. *J. Verbal Learning and Verbal Behavior*, vol. 12, no. 6, 1973, pp. 689-700.
77. Seymour, Philip H.: A Model for Reading, Naming and Comparison. *British J. Psych.*, vol. 64, no. 1, 1973, pp. 35-50.
78. Royer, F.: Spatial Orientational and Figural Information in Free Recall of Visual Figures. *J. Exp. Psych.*, vol. 91, no. 2, 1971, pp. 326-332.
79. Loftus, Elizabeth F.; and Palmer, John C.: Reconstruction of Automobile Destruction: An Example of the Interaction Between Language and Memory. *J. Verbal Learning and Verbal Behavior*, vol. 13, no. 5, 1974, pp. 585-589.
80. Carmichael, L.; Hogan, H. P.; and Walter, A. A.: An Experimental Study of the Effect of Language on the Reproduction of Visually Perceived Form. *J. Exp. Psych.*, vol. 15, 1932, pp. 73-86.
81. Hanawalt, N. G.; and Demarest, I. H.: The Effect of Verbal Suggestion Upon the Reproduction of Visually Perceived Forms. *J. Exp. Psych.*, vol. 25, 1939, pp. 159-174.
82. Bower, G. H.: Mental Imagery and Associative Learning. *Cognition in Learning and Memory*, L. W. Gregg, ed., Wiley (New York), 1972, pp. 51-88.
83. Royer, F. L.: Figural Goodness and Internal Structure in Perceptual Discrimination. *Perception and Psychophysics*, vol. 1, no. 9, 1966, pp. 311-314.
84. Chapanis, A.; and Lindenbaum, L.: A Reaction Time Study of Four Control-Display Linkages. *Human factors*, vol. 1, no. 4, 1959, pp. 1-7.