

NASA

National Aeronautics and
Space Administration

Space Transportation System

User Handbook

MAY 1982

TABLE OF CONTENTS

1 — Management and procedures

THE USER INTERFACE	1-1
STANDARD SYSTEMS	1-3
STS UTILIZATION	1-6
FLIGHT ASSIGNMENT	1-7
USER CHARGES	1-8
Basic charges	1-8
Shared-flight charges	1-10
Small self-contained payloads	1-11
TERMS AND CONDITIONS	1-12

2 — Flight systems

SHUTTLE SYSTEM	2-1
Performance capability	2-2
Induced environments	2-7
Payload accommodations	2-11
SAFETY AND INTERFACE VERIFICATION	2-23
Payload safety requirements	2-23
Payload interface verification requirements	2-23
SPACELAB	2-25
Basic configurations	2-27
Module segments	2-30
Common payload support equipment	2-32
Pallet structure	2-33
Instrument pointing system	2-34
Payload resources summary	2-34
Mission scenarios	2-37
UPPER STAGES	2-40
Payload assist module	2-41
Inertial upper stage	2-43
LONG DURATION EXPOSURE FACILITY	2-44
MULTIMISSION MODULAR SPACECRAFT	2-49
MMS systems and capabilities	2-49
Flight support system	2-52

3 — Launch and landing site operations

AN OVERVIEW	3-1
KSC OPERATIONS	3-3
Payload transportation	3-3
Payload processing	3-3
Spacelab ground flow	3-5
Upper stages ground flow	3-6
Postflight handling	3-10
KSC FACILITIES AND SERVICES	3-11
Buildings and test areas	3-11
Cargo support equipment	3-14
Services	3-18
KSC MANAGEMENT	3-19
Interfaces	3-19
Responsibilities	3-20
SAFETY CONSIDERATIONS	3-21
VANDENBERG LAUNCH SITE OPERATIONS	3-22

4 — Flight operations

FLIGHT PLANNING	4-1
Flight design	4-2
Crew activity planning	4-2
Operations planning	4-4
Training preparation	4-4
COMMUNICATIONS NETWORK	4-5
Tracking and Data Relay Satellite System	4-6
Space Flight Tracking and Data Network	4-8
Nascom	4-8
Payload control	4-8
Telemetry and data systems	4-9
MISSION CONTROL CENTER	4-11
PAYLOAD OPERATIONS CONTROL CENTER	4-13
Attached payloads	4-14
Free-flying automated payloads	4-16
Planetary payloads	4-18
TRAINING AND SIMULATIONS	4-20
Crew duties	4-20
STS crew training	4-21
Payload specialist training	4-23
Ground team	4-26

Appendixes

A References	A-1
B STS 100 Form	B-1
C Glossary of terms	C-1
D Acronyms	D-1

INTRODUCTION

The Space Transportation System will provide easier access to space for a wider range of users than ever before. This handbook is the beginning of a concentrated effort by NASA to explain and provide routine space operations.

As you need additional information in selected areas, you will find references to applicable documents and organizations to support your inquiries. In the United States, initial contacts for planning and questions of a general nature should be addressed to the Space Transportation System (STS) Utilization Office, Mail Code OT, National Aeronautics and Space Administration, Washington, D.C. 20546; telephone (202) 755-2350, Federal telecommunications system 755-2350. Users outside the United States should address initial inquiries to the Office of External Relations, International Affairs Division, Mail Code LI-15, National Aeronautics and Space Administration, Washington, D.C. 20546.

THE USER INTERFACE

Users of space in the Space Transportation System (STS) operations era will come from many sources. Within the United States, the NASA Centers will sponsor programs using the Space Transportation System. Other civilian governmental agencies and the Department of Defense will conduct continuing space programs. International participation will come both from individual experimenters and from organizations such as the European Space Agency and other various foreign government agencies. Commercial activities of a domestic and international nature will be prevalent.

The commercial utilization of space is being encouraged and commercial firms are also expected to become user representatives for single investigators.

The NASA use of the STS to conduct investigations in space will be programed by NASA Headquarters. General program projections will be published, followed by proposal solicitations for investigations on future flights. Universities, nonprofit organizations,

and industrial firms are encouraged to respond to the specific solicitations published in NASA announcements of opportunities. Current common contractual arrangements with organizations and principal investigators will apply (rather than user charges).

The prospective user's first act (see fig. 1-1) should be to call the STS Utilization Office at NASA Headquarters to obtain assistance. This office will provide advice on how to proceed to the next step. Experimenters will work with a key organization that interfaces with the STS organization; therefore, the individuals can devote their total energies to their own experiments. Major commercial, defense, and other similar users will interface directly with STS operations. European Space Agency (ESA) member states should first contact that organization (European Space Agency, 8-10, Rue Mario Nikis, 75738 Paris Cedex 15, France) regarding ESA-funded experiments. See appendix A for information about the ESA Spacelab Payload Accommodation Handbook.

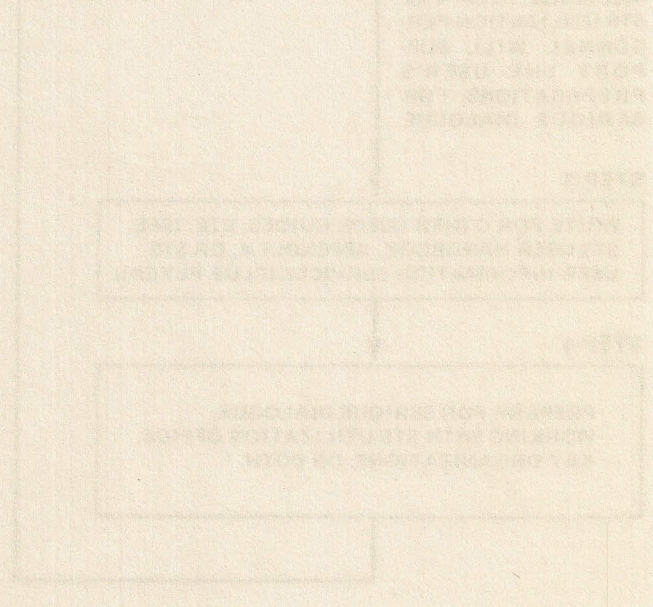
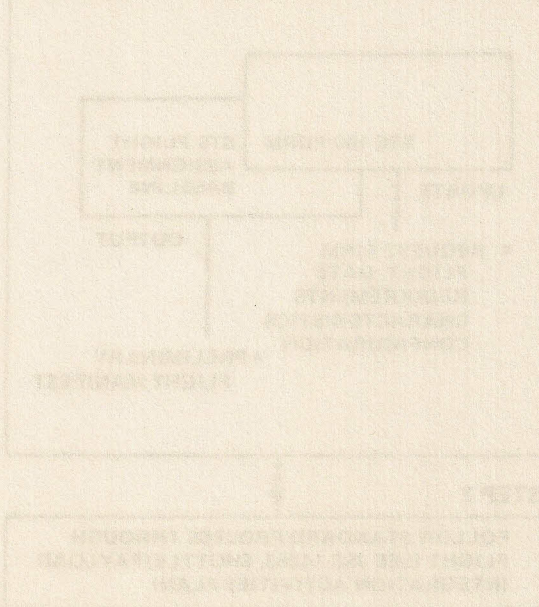

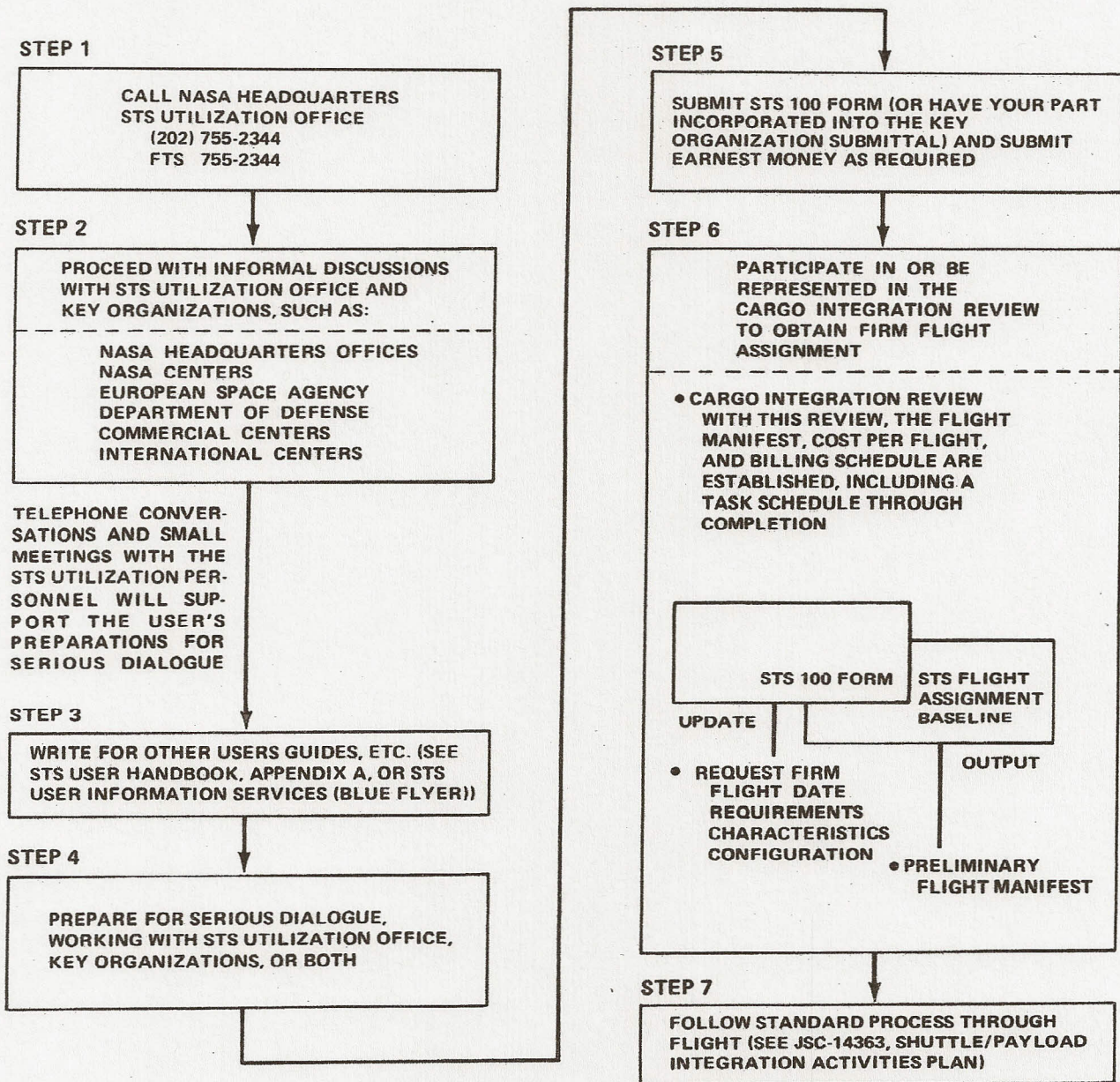

Figure 1-1.— Basic procedures for prospective users of the STS.

STANDARD SYSTEMS

The key to opening this new era of routine space operations—both on the ground and in orbit—is the Space Shuttle system (figs. 1-2 to 1-4). The Orbiter vehicle can accommodate many standard or unique payloads in its large cargo bay; it will also deliver into orbit other elements of the Space Transportation System.

Two kinds of upper stages will be used to deliver satellites beyond the Orbiter's Earth orbit. Satellites headed for geosynchronous, elliptic, and higher circular orbits or destined for deep space can use the large, solid inertial upper stage (IUS). Satellites of the Delta or Atlas-Centaur weight and volume class can use the payload assist module (PAM) to effect a smooth transition from existing expendable launch vehicles.

The Spacelab is an international project being undertaken by the European Space Agency. Its hardware components are a pressurized module (with a shirt-sleeve working environment) and open equipment pallets (exposed to the space vacuum). For any one flight, the Spacelab hardware can be arranged as a module only, a module with pallet, or pallets only. The single-pallet mode (without a module) will also share flights with other payloads.

Free-flying standard spacecraft now include the Multimission Modular Spacecraft and the Long Duration Exposure Facility. These satellites, designed to be reused, will be able to support a wide variety of operational or research instruments. See appendix A for reference documents.

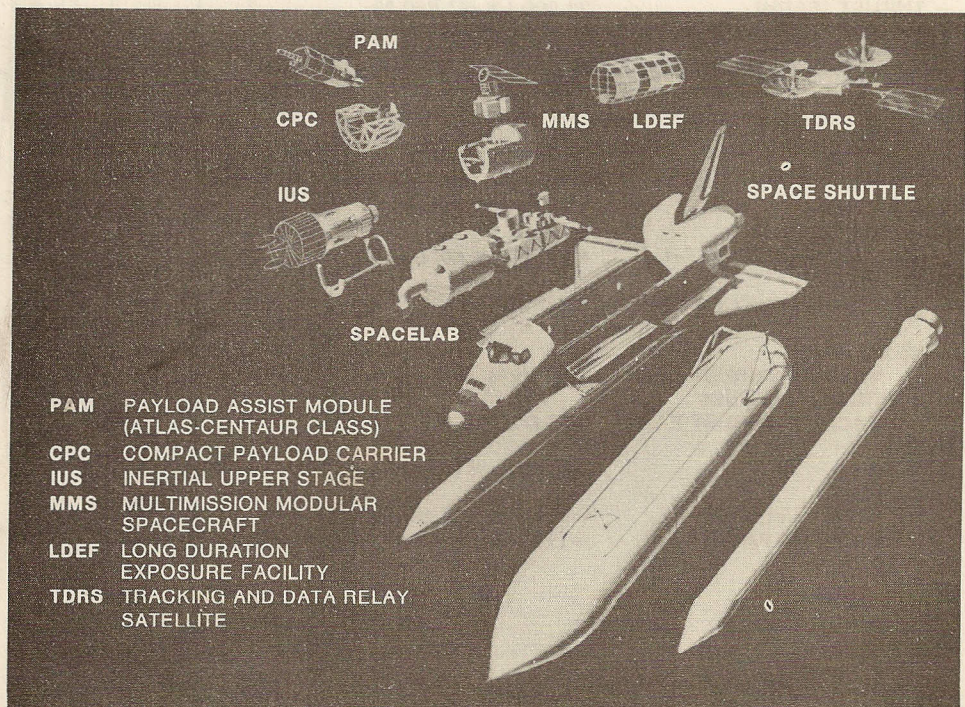

Figure 1-2.— STS elements.

SPACE SHUTTLE SYSTEM

OVERALL LENGTH	184.2 FT (56.1 m)
HEIGHT	76.6 FT (23.3 m)
SYSTEM WEIGHT	
- DUE EAST	4 490 800 LB (2037 Mg)
- 104°	4 449 000 LB (2018 Mg)
PAYLOAD WEIGHT	
- DUE EAST	65 000 LB (29 483 kg)
- 104°	32 000 LB (14 515 kg)

EXTERNAL TANK

DIAMETER	27.8 FT (8.5 m)
LENGTH	154.4 FT (47.1 m)
WEIGHT	
- LAUNCH	1 649 600 LB (748 242 kg)
- INERT	71 000 LB (32 205 kg)

SOLID ROCKET BOOSTER

DIAMETER	12.2 FT (3.7 m)
HEIGHT	149.1 FT (45.4 m)
WEIGHT (EACH)	
- LAUNCH	1 292 600 LB (586 310 kg)
- INERT	183 800 LB (83 370 kg)
THRUST (EACH)	
- LAUNCH	2 700 000 LB (12 010 140 N)
SEPARATION MOTORS (EACH SRB)	
- 4 AFT 4 FORWARD	
- THRUST (EACH)	22 000 LB (97 860 N)

ORBITER

LENGTH	122.2 FT (37.2 m)
WINGSPAN	78.1 FT (23.8 m)
TAXI HEIGHT	~57 FT (~17 m)
PAYLOAD BAY	15 FT DIAM BY 60 FT LONG (4.6 m BY 18.3 m)
CROSS RANGE	1100 N. MI. (2037 km)
MAIN ENGINES (3)	
- VACUUM THRUST EACH	470 000 LB (2090.7 kN)
OMS ENGINES (2)	
- VACUUM THRUST EACH	6000 LB (26.7 kN)
RCS	
- 38 ENGINES	
VACUUM THRUST EACH	870 LB (3869.9 N)
- 6 VERNIER ENGINES	
VACUUM THRUST EACH	25 LB (111.2 N)
WEIGHT	
- INERT	162 000 LB (73 482 kg)
- LANDING	
WITH PAYLOAD	~211 000 LB (95 707 kg)
WITHOUT PAYLOAD	~179 000 LB (81 193 kg)

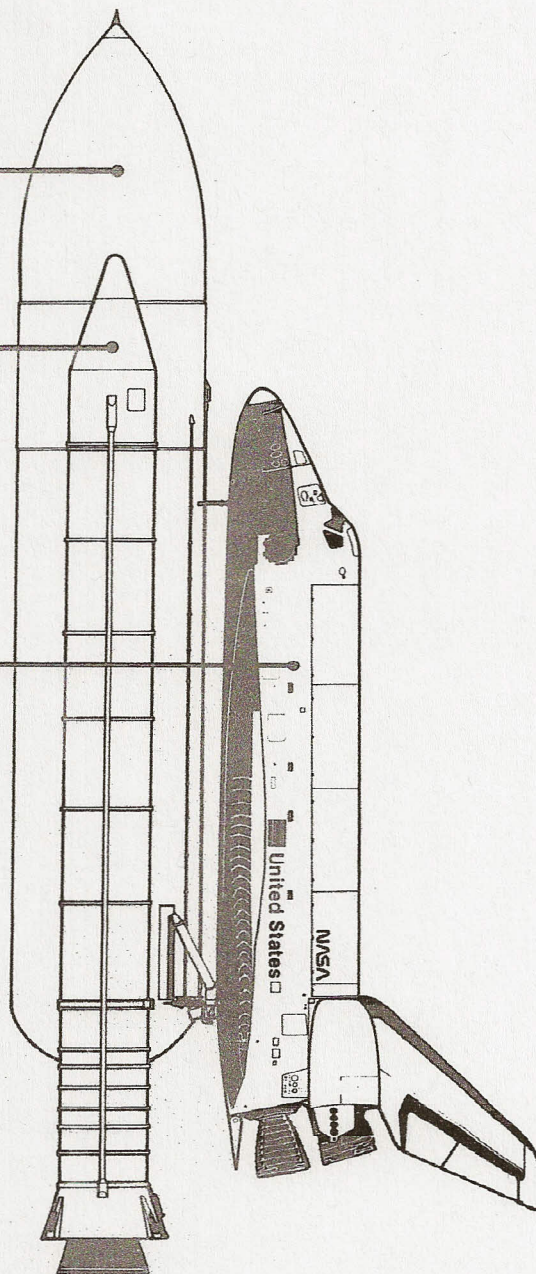

Figure 1-3.— Space Shuttle system.

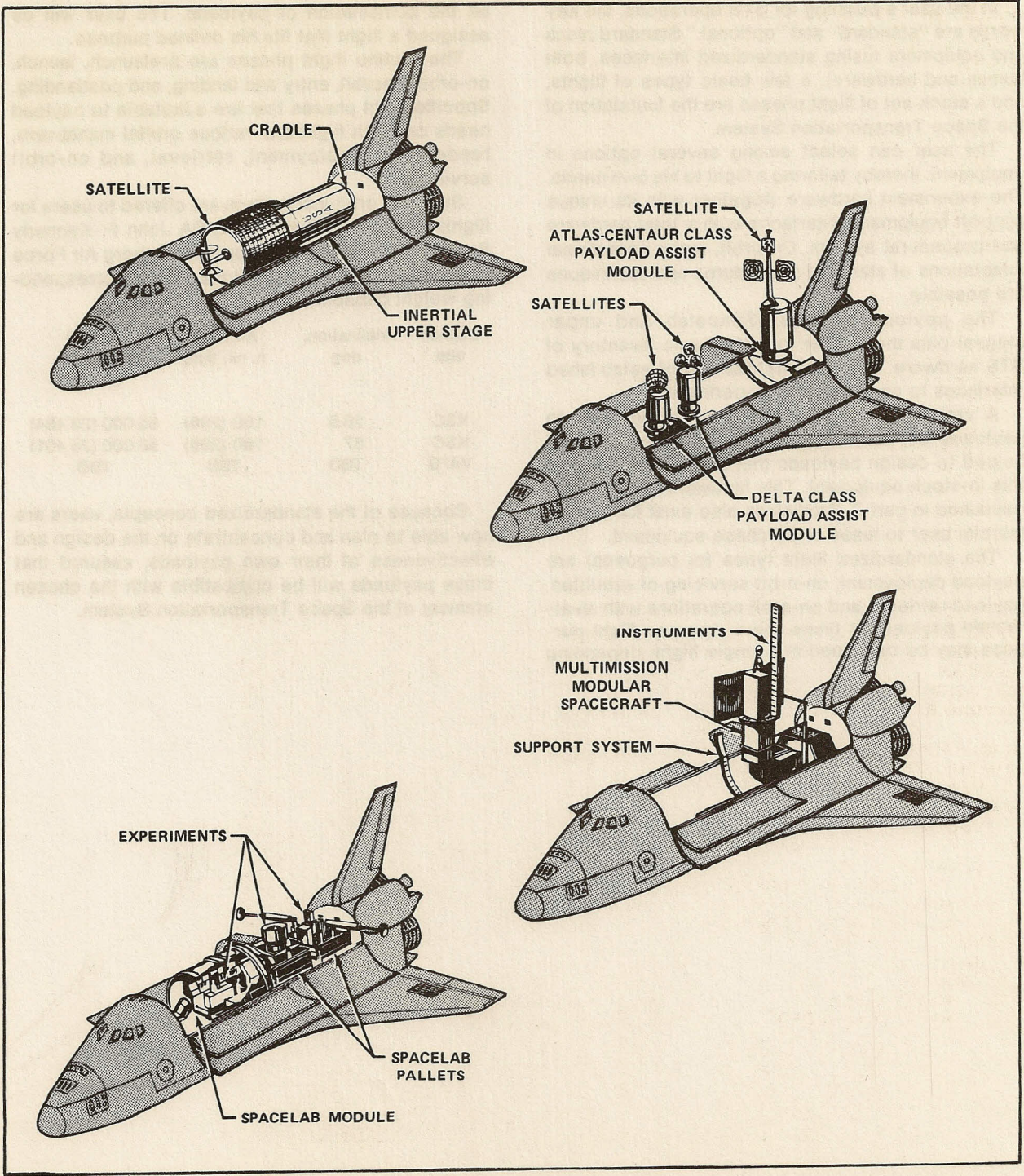

Figure 1-4.— Shuttle satellite configurations.

STS UTILIZATION

In the user's planning for STS operations, the key words are "standard" and "optional." Standard plans and equipment (using standardized interfaces, both human and hardware), a few basic types of flights, and a stock set of flight phases are the foundation of the Space Transportation System.

The user can select among several options in equipment, thereby tailoring a flight to his own needs. The experiment hardware (together with its unique support equipment) interfaces with a total hardware and procedural system. On orbit, many operational adaptations of standard procedures and techniques are possible.

The payload carriers (Spacelab and upper stages) plus the Orbiter form the basic inventory of STS hardware. Each has its own set of established interfaces to accommodate experiments.

A variety of support equipment is available to payloads as needed. Users are encouraged and helped to design payloads that are compatible with this in-stock equipment. This hardware is more fully explained in part 2. Provisions also exist for a commercial user to lease or purchase equipment.

The standardized flight types (or purposes) are payload deployment, on-orbit servicing of satellites, payload retrieval, and on-orbit operations with an attached payload. At times, more than one flight purpose may be combined in a single flight, depending

on the combination of payloads. The user will be assigned a flight that fits his defined purpose.

The routine flight phases are prelaunch, launch, on-orbit, deorbit, entry and landing, and postlanding. Specific flight phases that are adaptable to payload needs on each flight are various orbital maneuvers, rendezvous, deployment, retrieval, and on-orbit servicing.

Standard orbit inclinations are offered to users for flights originating from the NASA John F. Kennedy Space Center (KSC) and from Vandenberg Air Force Base (VAFB). These inclinations and the corresponding weight capabilities are listed below.

Launch site	Inclination, deg	Altitude, n. mi. (km)	Weight capability, lb (kg)
KSC	28.5	160 (296)	65 000 (29 484)
KSC	57	160 (296)	56 000 (25 401)
VAFB	TBD	TBD	TBD

Because of the standardized concepts, users are now able to plan and concentrate on the design and effectiveness of their own payloads, assured that those payloads will be compatible with the chosen element of the Space Transportation System.

FLIGHT ASSIGNMENT

The basic steps in finalizing a firm flight assignment are summarized in figure 1-5. The necessary form (STS 100) is included in appendix B.

The NASA Headquarters STS Utilization Office in Washington, D.C., after being contacted by an interested potential user, will assist user preparations for serious dialogue with one of its staff, with other NASA Headquarters personnel, or with personnel from a NASA field installation.

With the completion of the first formal review, the

user becomes part of a standard planning and implementation process. This gives the user insight into how his needs will be met, who his operating interfaces will be along the way, and what inputs from him will be necessary during the implementation process.

In many cases, small users will be assisted or represented by management or engineering organizations (commercial, government, etc.) in dialogue with the STS operations personnel.

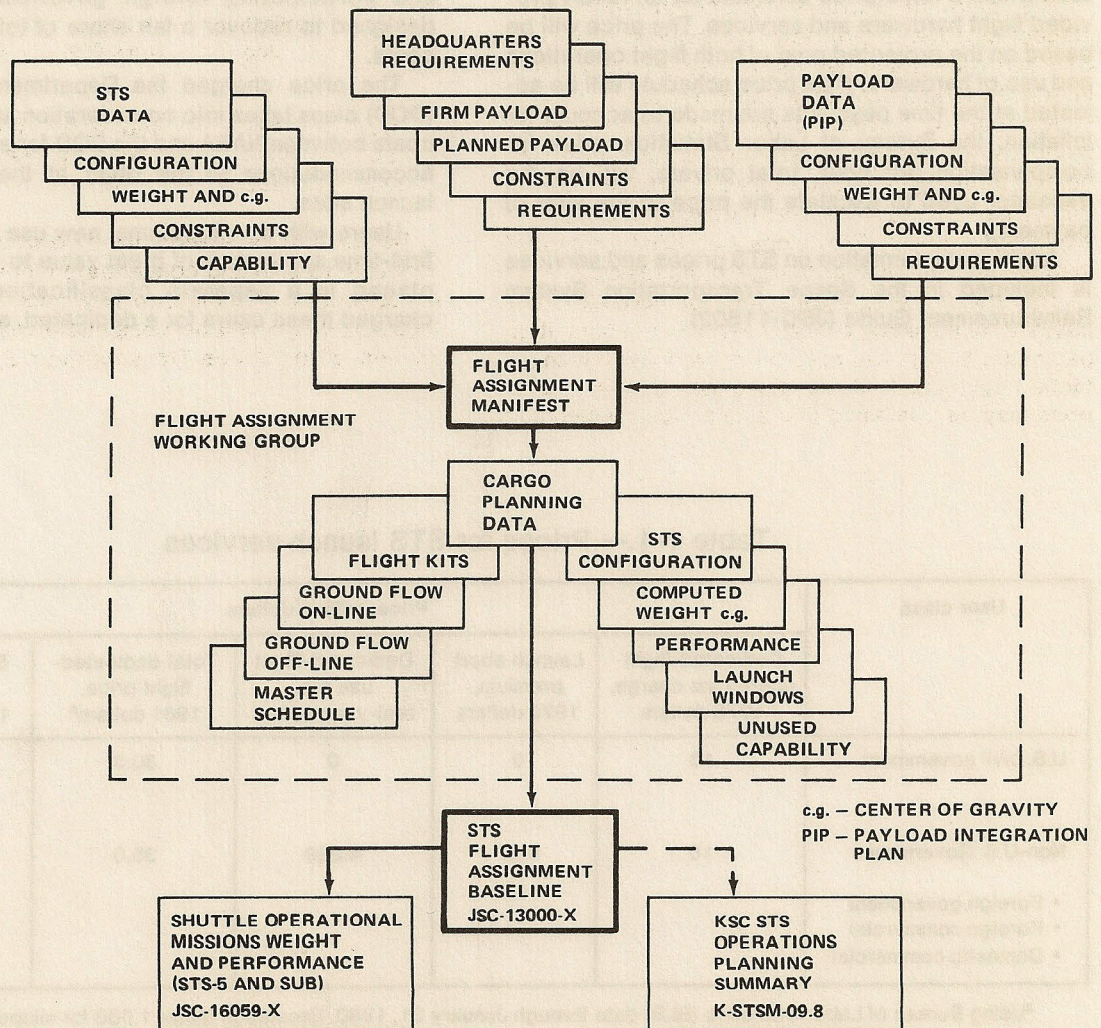

Figure 1-5.— Flight assignment process.

USER CHARGES

A pricing policy has been established that defines the user charges for STS services. A key part of this policy is establishing a fixed price (to be adjusted for inflation) during the early years of STS operations. NASA offers this fixed price in current-year dollars for the first 3 years of STS operation. After that, prices will be adjusted annually.

Additionally, the policy results in a price that permits economical transition from existing expendable launch vehicles to the STS. Finally, the STS pricing policy will reimburse NASA the cost to operate the STS.

User charges for a specific flight will be negotiated within a fixed-price schedule for all NASA-provided flight hardware and services. The price will be based on the projected cost of both flight operations and use of hardware. (The price schedule will be adjusted at the time payments are made to account for inflation; the Bureau of Labor Statistics index for compensation per hour, total private, will be the escalator used to escalate the price to the year of payment.)

Additional information on STS prices and services is included in the Space Transportation System Reimbursement Guide (JSC-11802).

Basic charges

The price for dedicated use of an entire Orbiter (excluding Spacelab, IUS, etc.) depends on the class of users. The price ranges are shown in table 1-1.

The price charged non-U.S. Government users (domestic or foreign) is designed to recover a fair share of the total operations costs and of the U.S. Government's investment in fleet, facilities, and equipment. The pricing structure is consistent with current U.S. policy on launch services to foreign countries and international organizations. The price charged to civilian agencies of the U.S. Government and participating foreign government users is designed to recover a fair share of total operations costs.

The price charged the Department of Defense (DOD) class takes into consideration an exchange of costs between NASA and the DOD for each providing accommodations to the other at their respective launch sites.

Users with an exceptional new use of space or a first-time application of great value to the public are placed in a separate classification. The price charged these users for a dedicated, standard Shut-

Table 1-1.— Prices for STS launch services

User class	Price, million dollars				
	Dedicated-flight operations charge, 1975 dollars	Launch abort premium, 1975 dollars	Dedicated-flight use fee, real-year dollars	Total dedicated-flight price, 1981 dollars ^a	Shared-flight price, ^b 1981 dollars ^a
U.S. civil government	18	0	0	30.3	673 per ft or 621 per lbm
Non-U.S. Government	18	0.27	4.298	35.0	778 per ft or 718 per lbm
<ul style="list-style-type: none"> • Foreign government • Foreign commercial • Domestic commercial 					

^aUsing Bureau of Labor Statistics (BLS) data through January 31, 1980. Escalation factor 1.683 for midpoint of calendar year 1980.

^bThousand dollars.

the flight will be the cost of conducting one additional flight during the overall STS program. The STS Exceptional Program selection process will determine which payloads qualify for this classification. In all instances, the NASA Administrator will be the selection official with final authority on the selection and price.

Certain prospective users must pay NASA \$100 000 earnest money before contract negotiations for a flight begin. This nonrefundable earnest money will be applied to the user's first payment.

The basic billing schedule for most users begins 33 months before the planned launch date. Users who contract for Shuttle services on shorter notice (1) will pay a higher total cost and (2) will pay on an accelerated schedule. This accelerated payment schedule will be used for short-notice contracts unless some offsetting advantages accrue to the U.S. Government in an accelerated launch schedule. (In that instance, the Government may waive some or all requirements.) The schedule for both normal and accelerated payments is shown in table 1-2.

A request for Shuttle services made less than 1 year before a flight is handled on a space-available basis or as a short-term callup option. The short-term callup option will be made available at the discretion of the NASA Administrator and is dependent upon the ability of the flight schedule to support such an option. Users are therefore encouraged to include future payloads in their early flight requests and/or

design future payloads for on-orbit storage rather than expect to be able to successfully obtain a short-term callup option.

NASA will make no charges after the flight except those negotiated in the contract as extra services.

Some price and schedule options are available to users for a fee.

1. Fixed-price options for flights in a given year beyond the 3-year fixed-price period may be made available by NASA. These fixed-price options, when offered, will be negotiated separately with the user.

2. Users can contract for a guaranteed launch date within a specified 90-day period by paying an additional fee of \$100 000, payable at the time the \$100 000 earnest money is paid. This \$200 000 will be applied to the user's first payment.

Users can postpone a flight one time at no additional cost if the notification is made more than 1 year before the scheduled flight date. Subsequent postponements or postponements occurring less than 1 year before the planned launch will cost 5 percent of the flight price plus an occupancy fee (explained in the next section). Any time a user cancels a flight, the cost is 10 percent of the flight price plus an occupancy fee. The occupancy fee affects only users of shared flights (described in the next sec-

Table 1-2.— Payment schedule

Contract initiation	Payment due, percent						Total percent
	Months before launch						
	33	27	21	15	9	3	
Nominal schedule (more than 33 months before launch date)	10	10	17	17	23	23	100
Accelerated schedule (months before launch date)							
27 to 32		21	17	17	23	23	101
21 to 26			40	17	23	23	103
15 to 20				61	23	23	107
9 to 14					90	23	113
3 to 8						122	122

tion). If postponement causes a payload to be launched in a year when a higher price has been established, the new price will apply.

Optional services available to users at a negotiable additional charge include payload revisit, use of Spacelab or other special equipment, use of flight kits to extend the basic Shuttle capability, use of upper stages, extravehicular activity by the flightcrew, unique payload/Orbiter integration and testing, payload mission planning (other than for launch, deployment, and reentry phases), additional days of STS support, payload data processing, payload specialist training, and unique user services at the launch site.

See the Space Transportation System Reimbursement Guide for details.

(TS) C

Shared-flight charges

For a payload that will not require an entire flight capability and that can share the cargo bay with others, the cost to the user will be a fraction of the dedicated-flight price, calculated as follows (see table 1-3).

1. The payload weight is divided by the Shuttle payload weight capability at the desired inclination to find the weight load factor. The figures shown are for the standard 160-nautical-mile (296-kilometer) orbit, with launch from KSC.

2. The payload length (including 6 inches (15 centimeters) for dynamic clearance) is divided by the length of the cargo bay, 60 feet (18.29 meters), to find the length load factor.

3. The load factor (length or weight, whichever is greater) is divided by 0.75 to determine the cost factor.

4. The calculated cost factor is multiplied by the price of a dedicated Shuttle flight (for the user's class) to determine the price for that payload.

For comparison, the fractions of a dedicated-flight price for payloads that currently are flying on expendable launch vehicles are as follows: Delta class payloads, one-fourth; Atlas-Centaur class payloads, one-half; and Titan class payloads, full flight price.

Users of shared flights who cancel or postpone a flight will be required to compensate a fair share of the risk to NASA if they are unable to find other suitable payloads to complete the cargo. The user pays any additional cost caused by schedule changes requested by the user. However, the user will not be penalized if NASA can recover those costs by manifesting other payloads on the same flight. Shared-flight users who require a short-term callup (or an accelerated launch schedule of less than 1 year) must pay a load factor recovery fee, which depends on how long before launch the option is exercised and on the availability of other payloads for the

Table 1-3.— Shared-flight price example

User/conditions	Required hardware	Launch weight, lbm	Shared-flight price, million dollars, 1981 dollars ^a
Non-U.S. Government user			
Communications satellite	Satellite with apogee motor	2700	9700 lbm × 718 per lbm = 6.96
2.5° inclination orbit	Upper stage	4700	
Weight critical	Cradle	<u>2300</u> 9700	

^aUsing BLS data through January 31, 1980. Escalation factor 1.683 for midpoint of calendar year 1980.

flight. A user paying this fee will still be flying for less than a dedicated flight would cost. Similarly, the occupancy fee for delayed or canceled flights depends on the time remaining before launch and on the availability of substitute payloads. In the event that substitute payloads cannot be found, the occupancy fees can be substantial. Therefore, users should make every effort to plan payload programs so that a launch need not be postponed or canceled less than a year before launch.

Shared-flight users who have paid fees in excess of the first payment due will receive credit on later payments.

A 20-percent discount will be given to shared-flight users who agree to fly on a space-available (standby) basis. NASA will provide launch services within a prenegotiated period of 1 year and the user will be notified 60 days before launch.

User charges do not apply to investigations conducted under contracts awarded in response to NASA solicitations for experiments or, when appropriate, awards based on unsolicited proposals. Potential users who wish to be placed on the mailing list for announcements of opportunities for submitting proposals for experiments or investigations in space should contact the Space Transportation Systems Utilization Office, Mail Code OT-6, National Aeronautics and Space Administration, Washington, D.C. 20546.

Small self-contained payloads

Shuttle services may be provided to a user for small (200 pounds (91 kilograms) or less and 5 cubic feet (0.14 cubic meter) or less) scientific research and development payloads that are flown on a space-available basis in a NASA-supplied container. The price ranges are as follows.

Maximum weight, lb (kg)	Maximum volume, ft ³ (m ³)	Cost, dollars
200 (91)	5 (0.14)	10 000
100 (45)	2.5 (.07)	5 000
60 (27)	2.5 (.07)	3 000

TERMS AND CONDITIONS

Use of the Space Transportation System involves certain terms and conditions imposed on both the user and NASA. Some of the more important ones are summarized here.

1. **Reflight guarantee.** For non-U.S. Government users, a reflight guarantee is included in the flight price. Other users can buy reflight insurance. The following services are provided under this guarantee.

a. The launch and deployment of a free-flying payload into a Shuttle-compatible mission orbit if the first attempt is unsuccessful through no fault of the user, if the payload returns safely to Earth or a second payload is provided by the user.

b. The launch of an attached payload into its mission orbit if the first attempt is unsuccessful through no fault of the user, if the payload is still in launch condition or a second payload is provided by the user.

c. The launch of a Shuttle into a payload mission orbit for the purpose of retrieving a payload if the first retrieval attempt is unsuccessful (this guarantee applies only if the payload is in a safe retrievable condition).

This reflight guarantee will not be applicable to payloads or upper stages required to place payloads into orbits other than the Shuttle mission orbit.

2. **Damage to payload.** The price does not include a contingency or premium for damage that may be

caused to a payload through no fault of the U.S. Government or its contractors. The U.S. Government, therefore, will assume no risk for damage or loss of the user's payload; the users will assume that risk or obtain insurance protecting themselves against such risk.

3. **Patent and data rights.** NASA will not acquire rights to a non-U.S. Government user's inventions, patents, or proprietary data that are privately funded or that arise from activities for which a user has properly reimbursed NASA. However, in certain instances, NASA may obtain assurances that the user will make available the results to the public on terms and conditions reasonable under the circumstances. The user will be required to furnish NASA sufficient information to verify peaceful purposes and to ensure Shuttle safety and compliance with the law and the Government's obligations.

4. **Launch schedule.** For users of a dedicated flight, 3 years before the desired launch date NASA will identify a launch time within a 3-month period. One year before the flight, firm payload delivery and launch dates will be negotiated with NASA. For shared-flight users, 3 years before the flight the desired launch date will be identified within a 90-day period. One year before the flight, a payload delivery date and a desired launch date will be coordinated among the shared-flight users and negotiated with NASA.

SHUTTLE SYSTEM

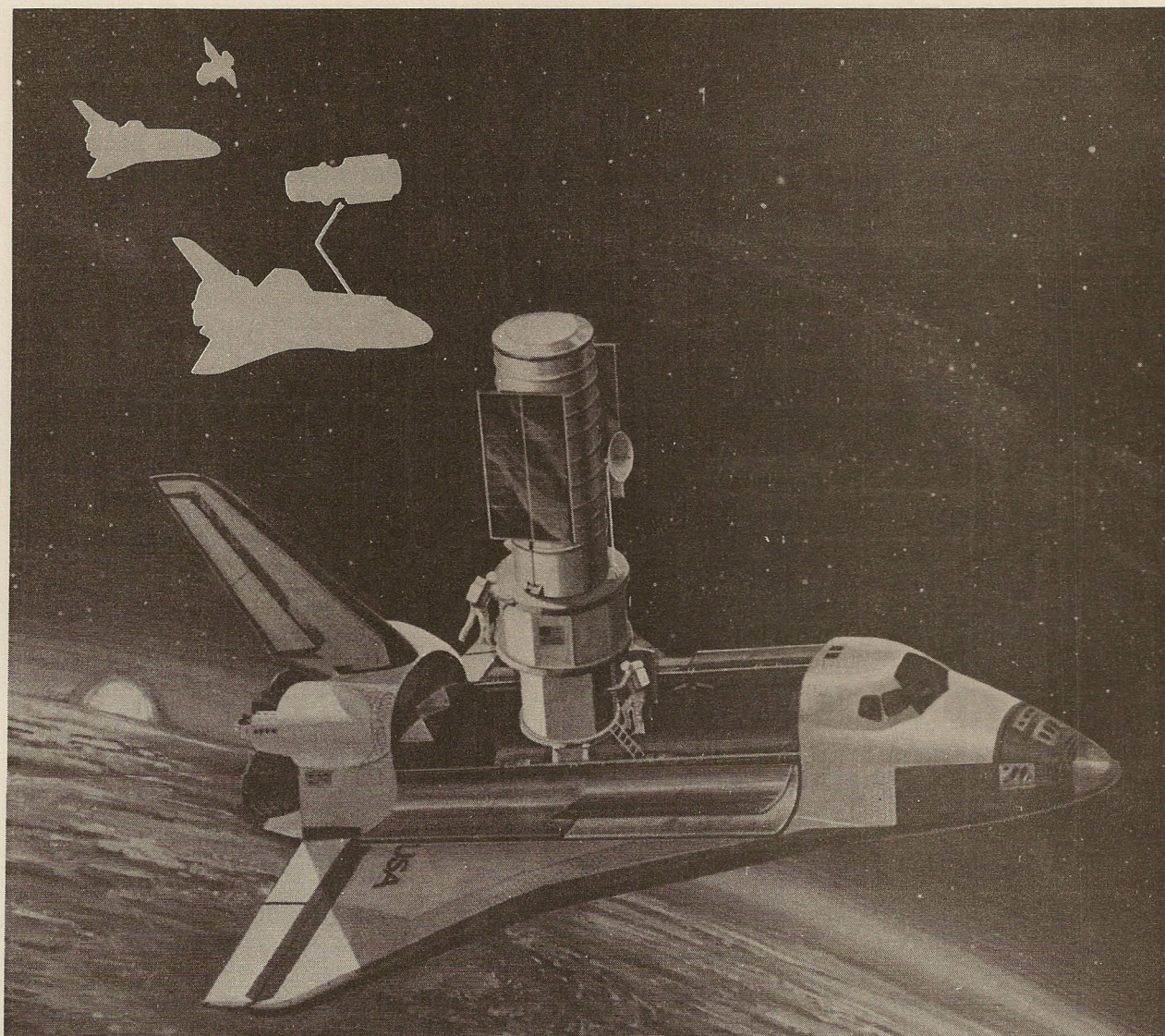

Shuttle system hardware and capabilities of importance to the user are summarized in this section. Induced environments and payload accommodations such as attachments, the remote manipulator system, electrical power availability, fluid and gas utilities, environmental control, communications links, data handling and displays, guidance and navigation systems, flight kits, and extravehicular activity (EVA) provisions are explained.

Users who expect to fly their experiments on a payload carrier (Spacelab, a propulsion stage, or a

free-flying satellite) should refer to the section for that carrier. In those instances, the experiment will be integrated with the payload carrier and will not have a primary interface with the Space Shuttle Orbiter.

Possible design and accommodations updates will be made available to users as soon as is practical. See appendix A, Shuttle Orbiter/Cargo Standard Interfaces (ICD-2-19001). Any resulting payload modifications are the responsibility of the user.

Performance capability

Launch limits

Operational flights will be launched from KSC in Florida beginning in late 1982 (fig. 2-1). Orbital inclinations of 28.5° to 57° can be obtained for circular and elliptic orbits.

Volume XIV of the Space Shuttle System Payload Accommodations (JSC-07700) contains individual

figures concerning circular orbits for both delivery-only missions and missions in which delivery and on-orbit rendezvous are needed for retrieving or servicing a payload; altitudes and weights for elliptic orbits; and orbital maneuvering systems. As many as three orbital maneuvering system (OMS) kits can be installed in the cargo bay for increased operational flexibility.

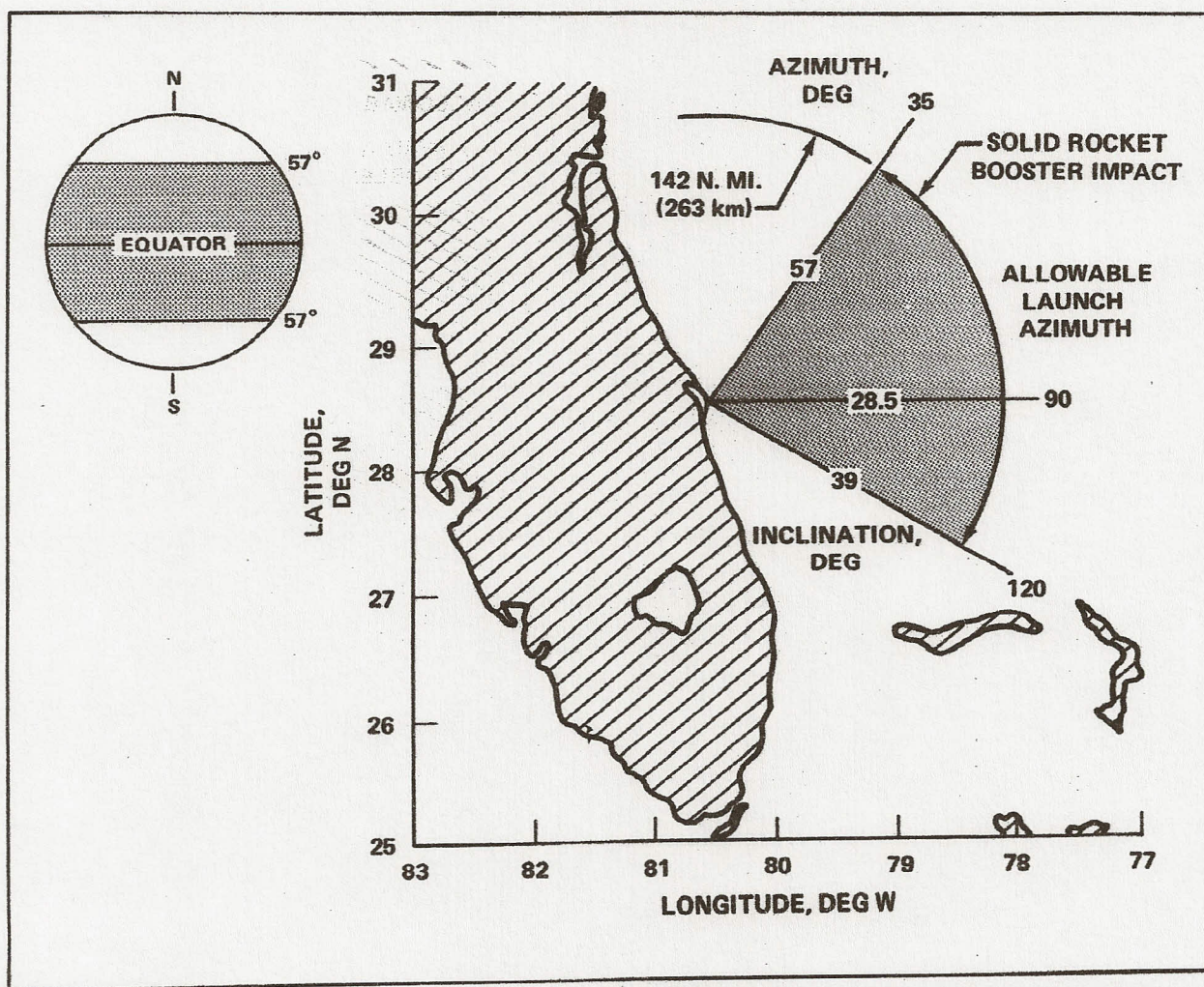

Figure 2-1.— Launch azimuth and inclination limits from KSC in Florida. The inset globe illustrates the extent of coverage possible when launches are made from KSC.

High-inclination orbits from Vandenberg Launch Site

Operational flights will also be launched from Vandenberg Launch Site (VLS) at Vandenberg Air Force Base (VAFB) in California beginning in 1984. Higher orbital inclinations (56° to 104°) (fig. 2-2) than from KSC can be obtained for circular and elliptic orbits. For circular orbits, both delivery-only flights and those in which delivery and on-orbit rendezvous are

needed can be accomplished. Elliptic orbits at a maximum inclination of 104° provide delivery only. Propellant loading with delta-V reserves are the same as for circular delivery-only flights.

The Shuttle cargo weight capability decreases rapidly as the inclinations become greater. Sun-synchronous orbital inclinations, for example, will require one or more OMS kits, depending on the desired orbital altitude and cargo weight.

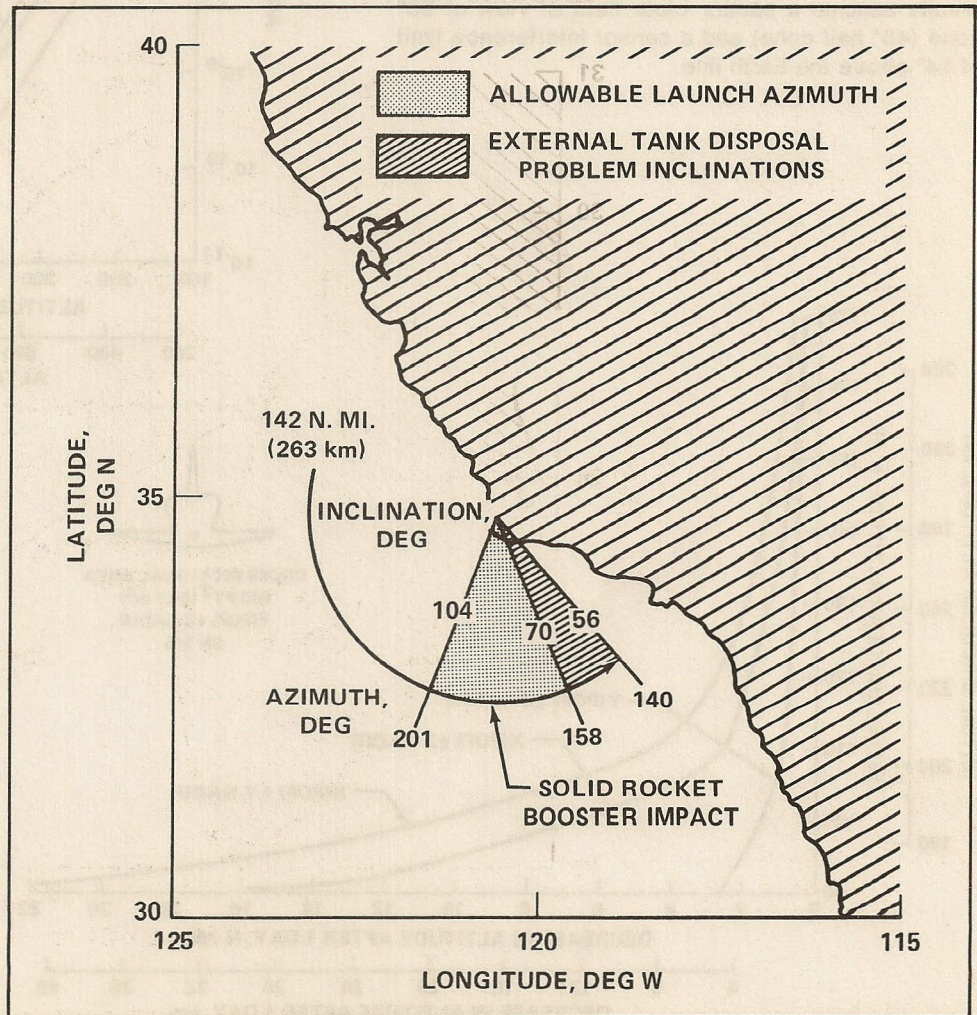

Figure 2-2.— Launch azimuth and inclination limits from VLS in California.

Free-drift Orbiter mode

Estimates of the on-orbit acceleration levels, velocity increment makeup, and altitude decrease resulting from atmospheric drag on the Orbiter in a free-drift mode of operation are shown in figure 2-3. The drawings on the right show which axis of the spacecraft is perpendicular to the orbit plane (POP) in the three attitude orientations. The ballistic numbers (BN's) are based on a 200 000-pound (90 700-kilogram) Orbiter having a drag coefficient of 2.0.

Typical experiment observation times for two possible free-drift modes are shown in figure 2-4 for a set of sample assumptions and cases at an orbital altitude of 250 nautical miles (465 kilometers). The results assume a sensor clear field of view of 90° cone (45° half cone) and a sensor interference limit of 14° above the Earth line.

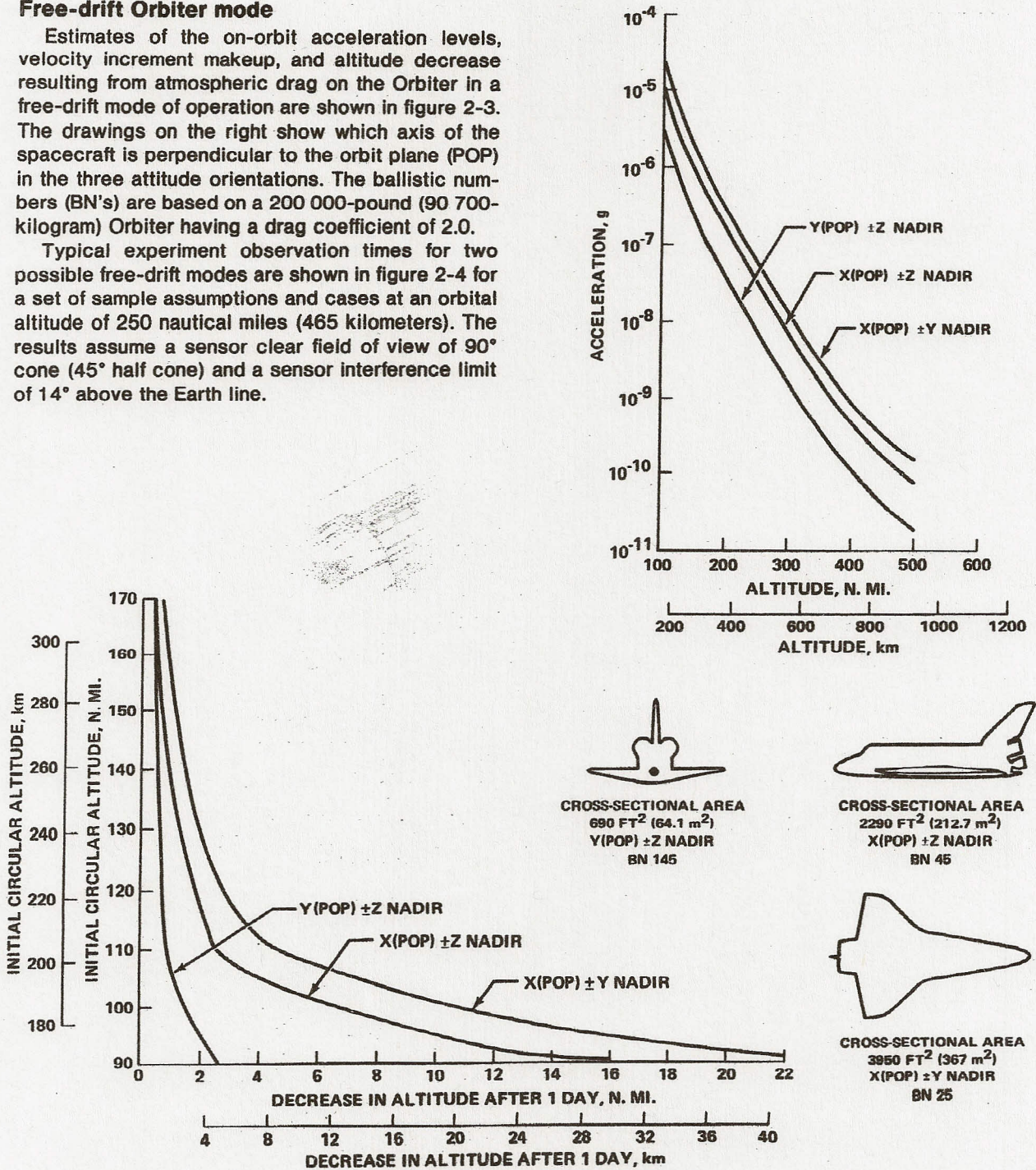
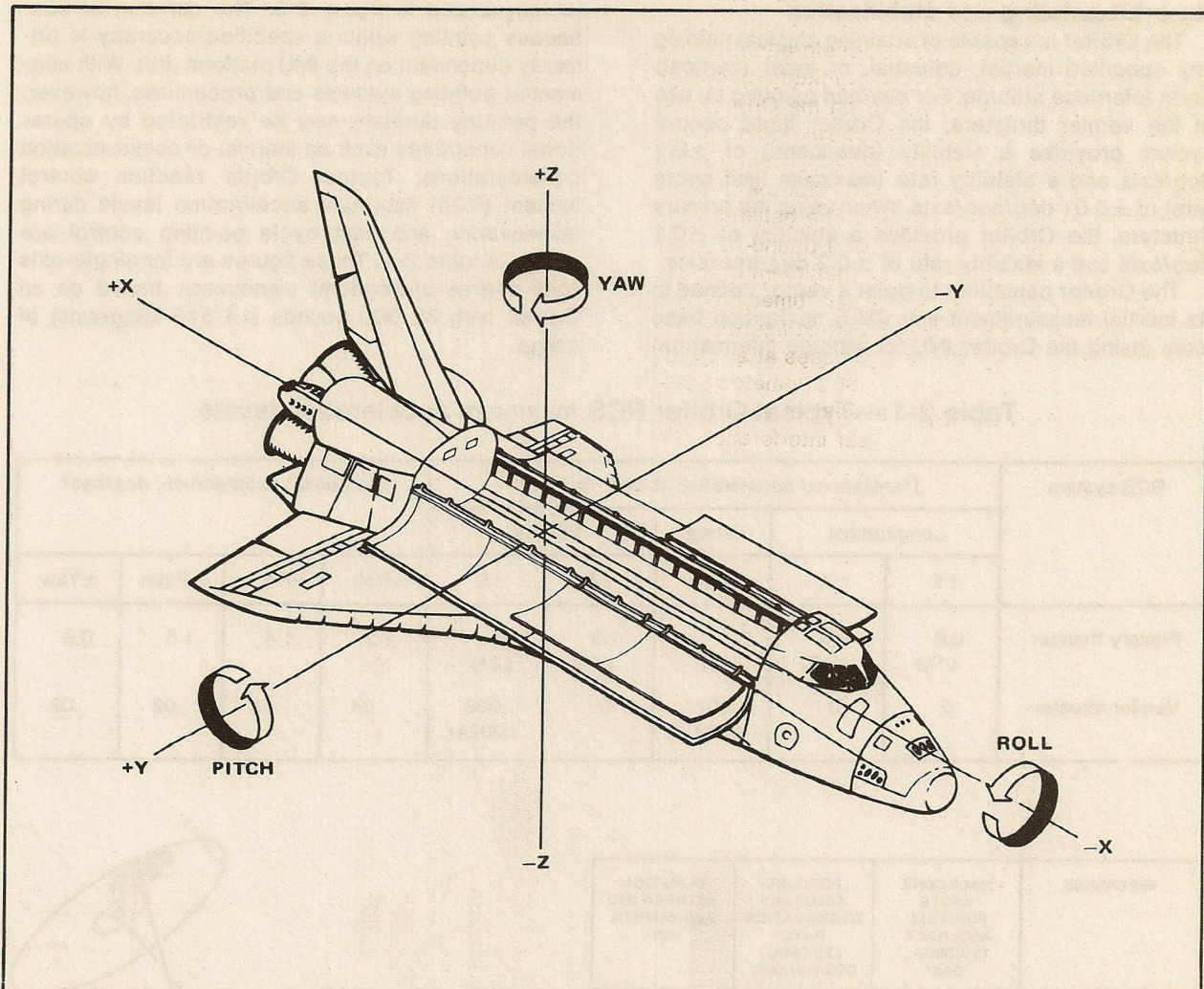

Figure 2-3.— Effects of atmospheric drag on the Orbiter.



Flight mode		Maximum gimbal rates, deg/sec		Maximum observation time, min
		Pitch or yaw	Roll	
Gravity gradient stabilized	Y-POP, X-nadir	0.064	0.045	< 13.6
	Z-POP, X-nadir	0.045	0.064	> 50.7 ^a
Quasi-inertial (selected inertial attitude/attitude rate)	Y-POP	+0.048, -0.034	0.034	< 50.7 ^a
	Z-POP	0.034	+0.048, -0.034	> 50.7 ^a

^aLimited by Earth interference

Figure 2-4.— Observation parameters for selected free-drift modes.

On-orbit pointing and stabilization

The Orbiter is capable of attaining and maintaining any specified inertial, celestial, or local (vertical) Earth reference attitude. For payload pointing by use of the vernier thrusters, the Orbiter flight control system provides a stability (deadband) of ± 0.1 deg/axis and a stability rate (maximum limit cycle rate) of ± 0.01 deg/sec/axis. When using the primary thrusters, the Orbiter provides a stability of ± 0.1 deg/axis and a stability rate of ± 0.2 deg/sec/axis.

The Orbiter capability to point a vector defined in its inertial measurement unit (IMU) navigation base axes (using the Orbiter IMU for attitude information)

is summarized in figure 2-5. The duration of continuous pointing within a specified accuracy is primarily dependent on the IMU platform drift. With augmented pointing systems and procedures, however, the pointing duration may be restricted by operational constraints such as thermal or communication considerations. Typical Orbiter reaction control system (RCS) maximum acceleration levels during maneuvering and limit cycle pointing control are shown in table 2-1. These figures are for single-axis (one-degree-of-freedom) maneuvers, based on an Orbiter with 32 000 pounds (14 515 kilograms) of cargo.

Table 2-1.—Typical Orbiter RCS maximum acceleration levels

RCS system	Translational acceleration, ft/sec ² (m/sec ²)					Rotational acceleration, deg/sec ²			
	Longitudinal		Lateral	Vertical		\pm Roll	+Pitch	-Pitch	\pm Yaw
	+X	-X	\pm Y	+Z	-Z				
Primary thruster	0.6 (.18)	0.5 (.15)	0.7 (.21)	1.3 (.40)	1.1 (.34)	1.2	1.4	1.5	0.8
Vernier thruster	0	0	.007 (.0021)	0	.008 (.0024)	.04	.03	.02	.02

REFERENCE	HALF-CONE ANGLE POINTING ACCURACY (3 SIGMA), DEG ^a	POINTING ACCURACY DEGRADATION RATE (3 SIGMA), DEG/HR/AXIS	DURATION BETWEEN IMU ALINEMENTS, HR
INERTIAL AND LOCAL VERTICAL	± 0.5	0.105	1.0
AUGMENTED INERTIAL	$\pm .44$	0	NA
EARTH-SURFACE FIXED TARGET	$\pm .5$.105	.5

^aMECHANICAL AND THERMAL TOLERANCES MAY DEGRADE POINTING ACCURACY AS MUCH AS 2°.

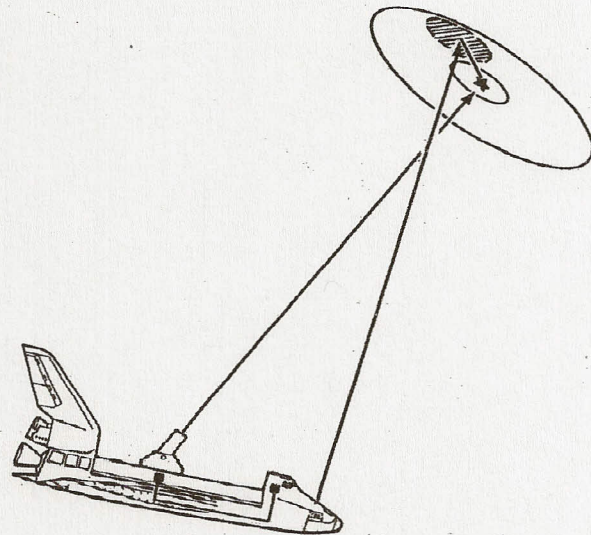

Figure 2-5.— Total (half-cone angle) pointing accuracy using the Orbiter IMU.

Induced environments

Payload environments will vary for specific missions and will also depend on the spacecraft involved (type of free-flying system or Spacelab configuration, for example). Therefore, data in this section are general in nature. The figures represent recommended design qualification test levels.

Vibration caused by noise

The Orbiter is subjected to random vibration on its exterior surfaces by acoustic noise (generated by the engine exhaust) and by aerodynamic noise (generated by airflow) during powered ascent through the atmosphere. These fluctuating pressure

loads are the principal sources of structural vibration. Actual vibration input to payloads will depend on the transmission characteristics of the mid-fuselage payload support structure and interactions with each payload's weight, stiffness, and center of gravity.

Vibration resulting from acoustic spectra is generated in the cargo bay by the engine exhaust and by aerodynamic noise during atmospheric flight. These predicted maximums are illustrated in figure 2-6. The data presented are based on an empty cargo bay and may be modified by the addition of payloads, depending on their characteristics. Aerodynamic noise during entry is significantly less than during ascent.

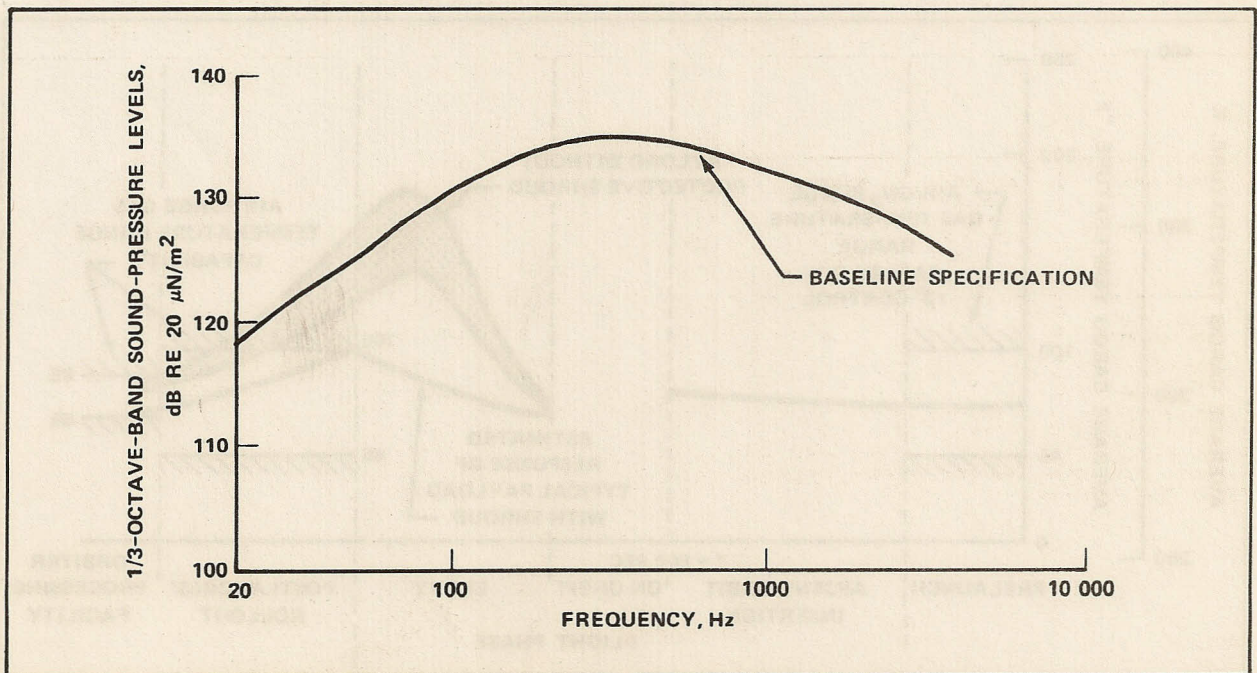

Figure 2-6.— Analytical prediction of maximum Orbiter cargo bay acoustic spectra.

Thermal control

During ground operations, the thermal environment of the cargo bay is carefully controlled by purging. Air-conditioning and purge requirements are defined by analysis for each launch.

During the ascent trajectory, the Orbiter construction and insulation limit the Orbiter-induced heat loads on the payload.

In space, with the cargo bay doors open, heating of payload components is based on the thermal, thermophysical, and geometric characteristics of each component. Additional factors influencing the incident thermal environment are launch date and hour, vehicle orientation, and orbital altitude. For preliminary calculations, the optical properties of the cargo bay liner, the Orbiter radiators, and the insulated forward and aft bulkhead surfaces are as follows, where α is absorption and ϵ is emissivity:

Cargo bay liner	$\alpha/\epsilon \leq 0.4$
Radiator surface	$\alpha/\epsilon = 0.10/0.76$
Forward and aft bulkheads	$\alpha/\epsilon \leq 0.4$

The Orbiter is designed for attitude hold capabilities. During the 3-hour thermal-conditioning periods, the vehicle rolls at approximately 2 to 5 revolutions per hour (barbecue mode) about the X-axis with the orientation of the X-axis perpendicular to the Earth-Sun line within $\pm 20^\circ$, or it can be oriented at preferred thermal attitudes. On-orbit thermal conditioning lasting as long as 12 hours (before the deorbit maneuver) is allocated for missions on which the thermal protection system temperatures exceed the design limits associated with a single-orbit mission.

Cargo temperatures for a typical flight, with emphasis on the entry phase, are shown in figure 2-7.

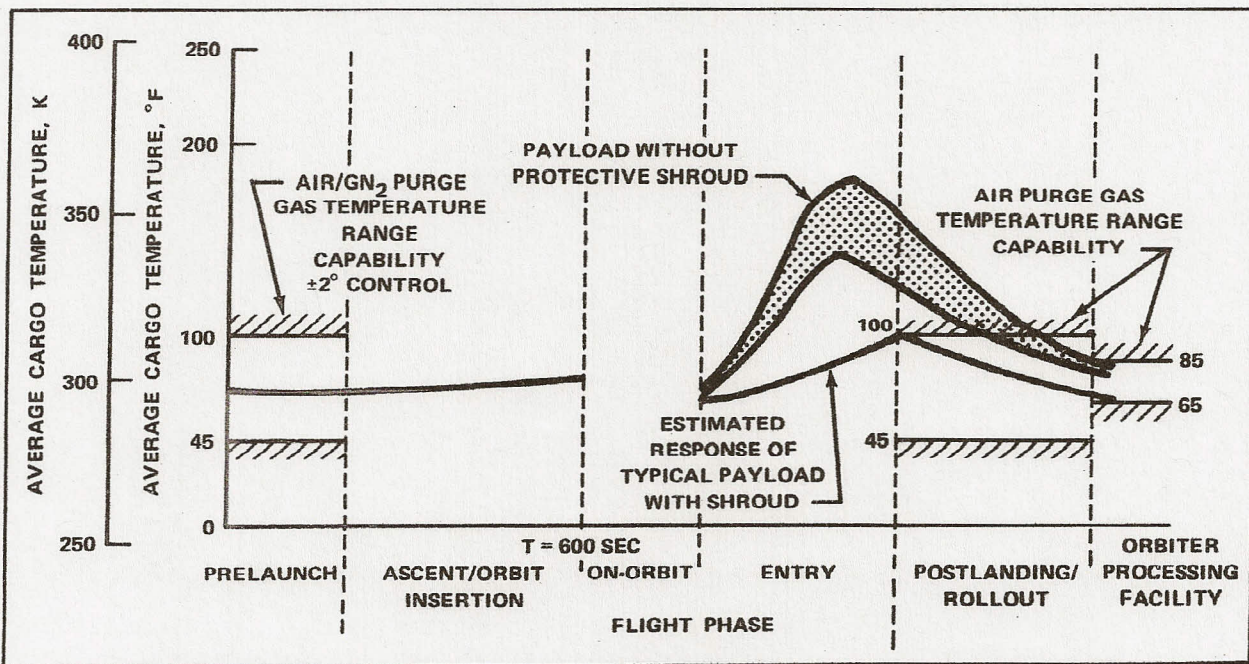

Figure 2-7.— Cargo bay thermal environment during the phases of a typical flight.

Payload limit load factors

The payload structure and substructure must be designed with the appropriate margin of safety to function during all expected loading conditions, both in flight and during ground handling. The limit load factors at the payload center of gravity are shown in table 2-2. The recommended margin of safety to apply to these limit load factors is 1.4.

Cargo load factor/angular acceleration is defined as the total externally applied force/moment on the cargo or cargo component divided by the corresponding total or component weight/moment of inertia. It carries the sign of the externally applied force/moment in accordance with the Orbiter coordinate system.

The Orbiter vehicle is designed for safe crew egress following emergency landing or water ditching. Hence, the mounting structures for equipment

and crew provisions in the Orbiter crew compartment and for large equipment items, pressure vessels, and payload attachments shall be designed to load factors equal to or greater than +20.0 to -3.3 along the X-axis, ± 3.3 along the Y-axis, and +10.0 to -4.4 along the Z-axis.

Payload equipment inside the Orbiter crew compartment shall be designed to preclude hazards to flight personnel after the application of emergency landing loads. In addition, the attachment structures (including fittings and fasteners) of the payloads must be designed for emergency landing loads to prevent failures that could result in injury to personnel or prevent egress from the emergency-landed vehicle.

The emergency landing design accelerations are considered ultimate; therefore, a 1.0 margin of safety should be applied.

Table 2-2.—Limit load factors^a

Condition	Load factor ^b		
	X-axis	Y-axis	Z-axis
Lift-off	-0.2	± 1.4	2.5
	-3.2	± 1.4	-2.5
Ascent	-1.1	$\pm .40$.25
	-3.2	$\pm .40$	-.59
Entry	1.01	$\pm .85$	2.5
	-1.5	$\pm .85$	-1.0
Landing	1.8	± 1.5	4.2
	-2.0	± 1.5	-1.0

^aFor 65 000 lb (29 485 kg) up and 32 000 lb (14 515 kg) down.

^bSix points on the cargo that are cantilevered or have substantial internal flexibility may experience higher loads than those reflected by this table.

Landing shock

Landing shock is another factor that must be considered in payload structure design. Rectangular pulses of the following peak accelerations will be experienced.

Acceleration, g-peak	Duration, msec	Applications per 100 flights
0.23	170	22
.28	280	37
.35	330	32
.43	360	20
.56	350	9
.72	320	4
1.50	260	1
		<hr/>
		125

Consideration should be given to analyzing the landing shock environment in lieu of testing, because the g-levels are relatively low in comparison to the basic design shock. Testing must be performed only on those items not covered in a static structural stress analysis.

Contamination control

Contamination control systems as well as various techniques to eliminate or minimize contamination are provided by the Orbiter design and standard flight plans. The sensitivity of most payloads to contamination is recognized and each mission can be tailored to meet specific requirements. Before lift-off and after landing, the cargo bay is purged and conditioned as specified in the description of thermal controls. At launch and during early ascent, the cargo bay vents are closed to prevent exhaust products and debris from entering the bay. During final ascent and through orbit insertion, the cargo bay is depressurized and the payload is generally not subjected to contaminants. On orbit there are three major sources of contamination: RCS vernier firings, dumping of potable water, and release of particulates and outgassing.

During deorbit and descent, the cargo bay vents are closed to minimize ingestion of contaminants created by the Orbiter systems. During the final phase of reentry, the vents must be opened to repressurize the Orbiter. To help prevent contamination during this phase, the vents are located where the possibility of ingestion is minimal.

Payload accommodations

The Orbiter systems are designed to support a variety of payloads and payload functions (fig. 2-8). The payload and mission stations on the flight deck provide space for payload-provided command and control equipment for payload operations required by the user. Remote-control techniques can be managed from the ground when desirable. When used, the Spacelab provides additional command and data management capability plus an additional pressurized work area for the payload specialists. The following supporting subsystems are provided for payloads.

- Payload attachments
- Remote manipulator handling system
- Electrical power, fluids, and gas utilities
- Wire harnesses
- Control panels
- Small self-contained payloads (SSCP's)
- Environmental control
- Communications, data handling, and displays
- Guidance and navigation
- Flight kits
- EVA capability when required

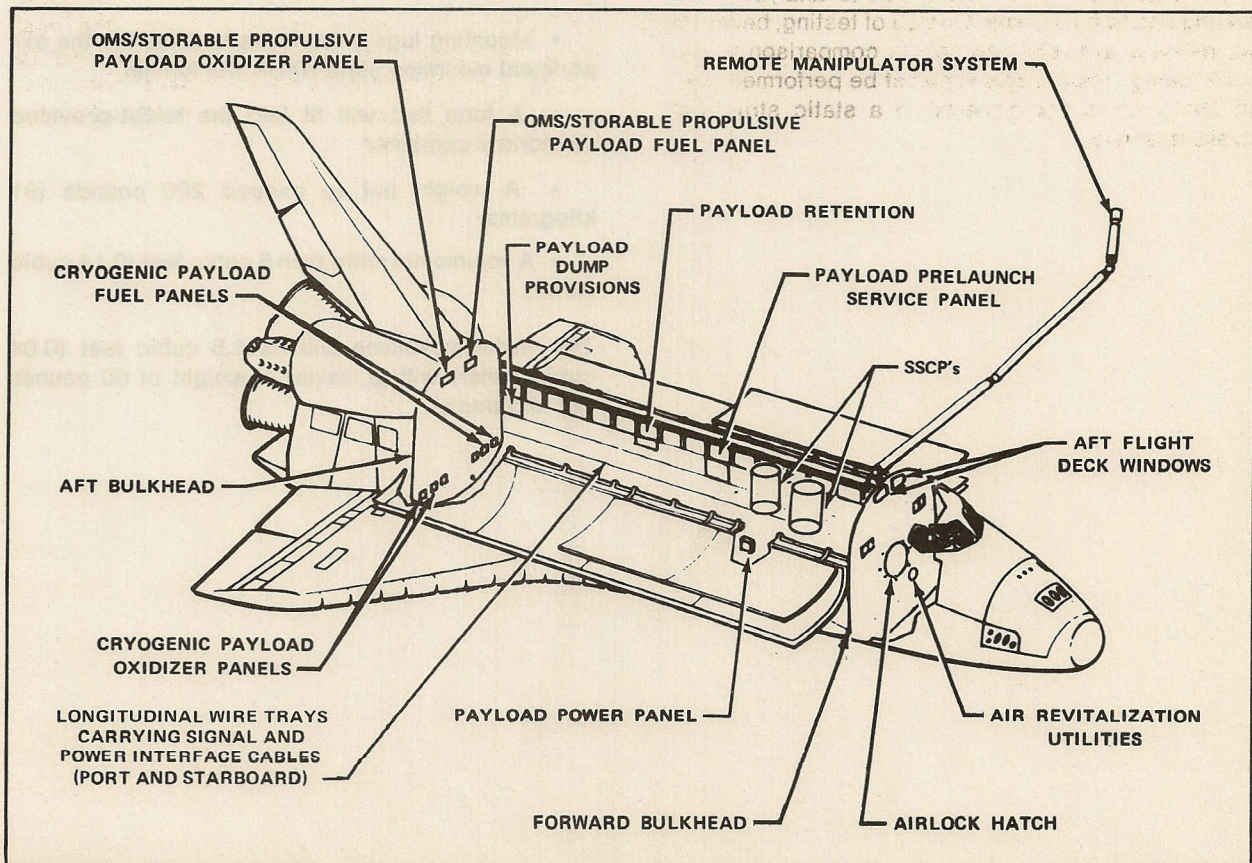

Figure 2-8.— Principal Orbiter interfaces with payloads.

Payload accommodations are described in detail in Space Shuttle System Payload Accommodations (JSC-07700, Vol. XIV, and ICD-2-19001).

The Orbiter systems can accommodate a number of payloads on each flight, depending on the size, weight, and service requirements of each. In shared flights, a standard allocation of services is offered to each user. The basis of allocation is the load factor. Power, wiring, control panels, uplink, downlink, software, and other services are allocated in four equal sections. One or more standard sections are assigned each user as a function of his load factor, if the load factor is one-eighth or greater. In Spacelab flights, the majority of Orbiter services are routed to the Spacelab and apportioned to experiments by the Spacelab mission manager.

Small self-contained payload/getaway special

On each Space Shuttle flight, there will be one or more primary payloads in the Shuttle's payload bay. However, such payloads will not always occupy the total space available or add up to the maximum allowable weight. A program, the small self-contained payload or "getaway special" (SSCP/GAS) (fig. 2-9), has been established to fly small experiments that will take advantage of the extra space/weight opportunities as they arise. This constitutes an unusual opportunity for individuals, commercial firms, and educational institutions that would like to conduct experiments in space at a moderate cost.

Small self-contained payloads shall be used only to conduct experiments of a scientific research and development nature. The payload must be a package that has

- Mounting lugs or surfaces to attach to the experiment mounting plate NASA will furnish
- A form that will fit into the NASA-provided cylindrical container
- A weight not to exceed 200 pounds (91 kilograms)
- A volume not more than 5 cubic feet (0.14 cubic meter)

The minimum volume will be 1.5 cubic feet (0.04 cubic meter) with a maximum weight of 60 pounds (27 kilograms).

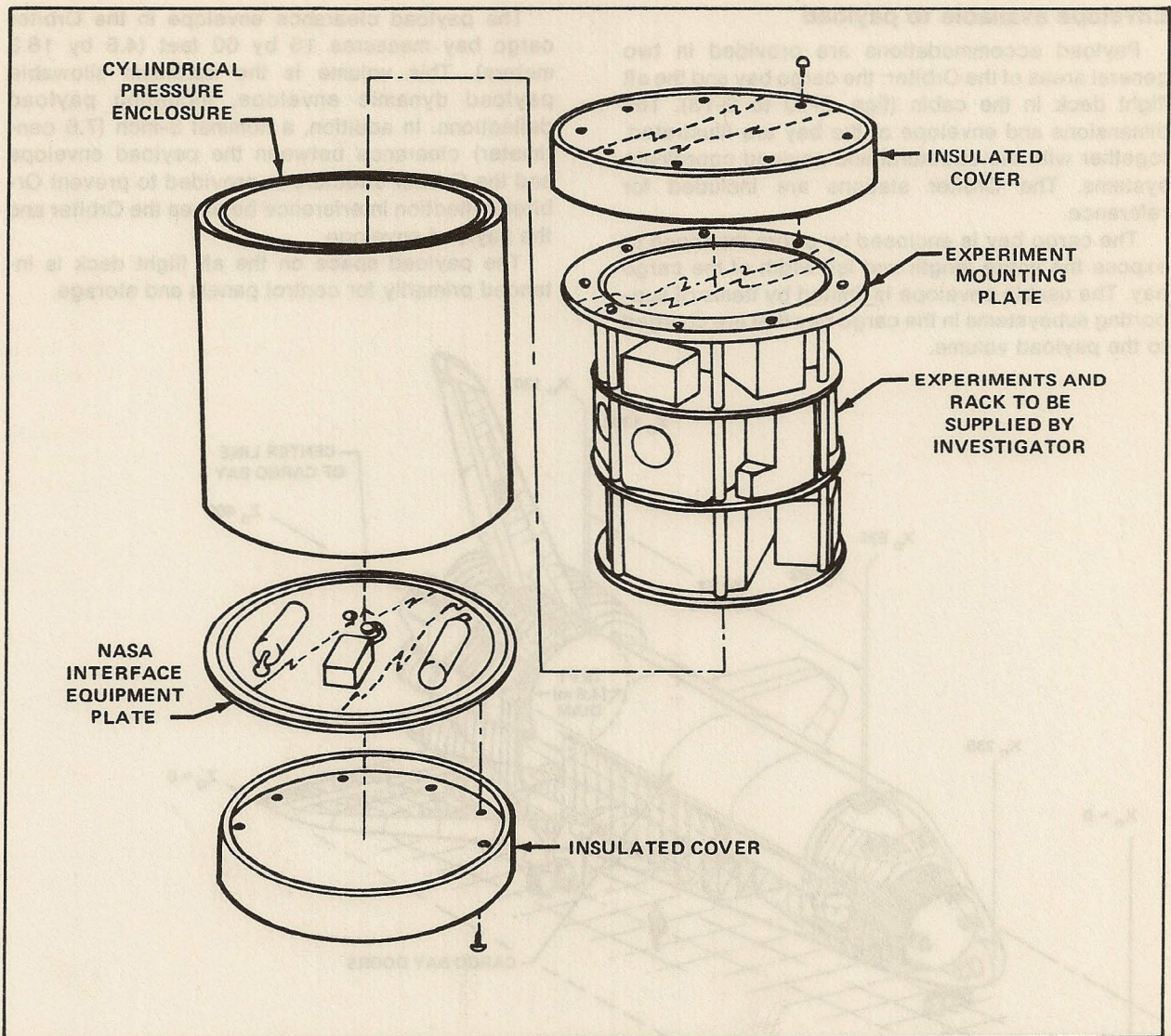

Figure 2-9.—“Getaway special” small self-contained payloads container concept.

Envelope available to payload

Payload accommodations are provided in two general areas of the Orbiter: the cargo bay and the aft flight deck in the cabin (figs. 2-10 to 2-13). The dimensions and envelope of the bay are illustrated, together with the structural and payload coordinate systems. The Orbiter stations are included for reference.

The cargo bay is enclosed by doors that open to expose the entire length and full width of the cargo bay. The usable envelope is limited by items of supporting subsystems in the cargo bay that are charged to the payload volume.

The payload clearance envelope in the Orbiter cargo bay measures 15 by 60 feet (4.6 by 18.3 meters). This volume is the maximum allowable payload dynamic envelope, including payload deflections. In addition, a nominal 3-inch (7.6 centimeter) clearance between the payload envelope and the Orbiter structure is provided to prevent Orbiter deflection interference between the Orbiter and the payload envelope.

The payload space on the aft flight deck is intended primarily for control panels and storage.

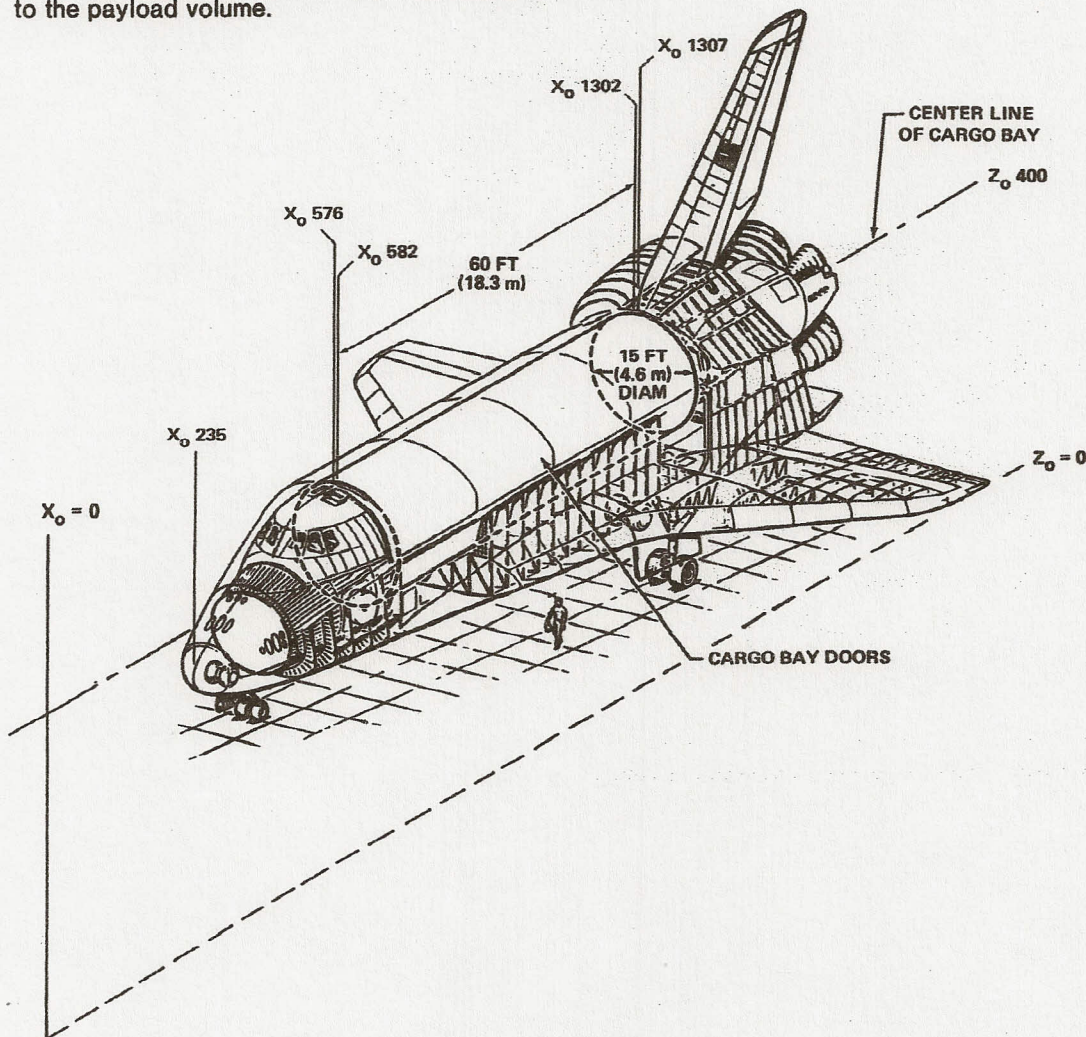

Figure 2-10.— Orbiter coordinate system and cargo bay envelope. The dynamic clearance allowed between the vehicle and the payload at each end is also illustrated.

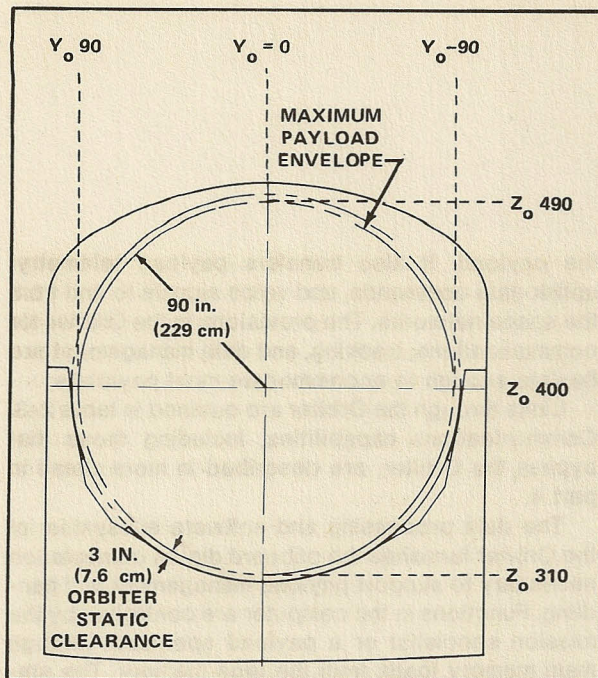

Figure 2-11.— View of payload envelope looking aft.

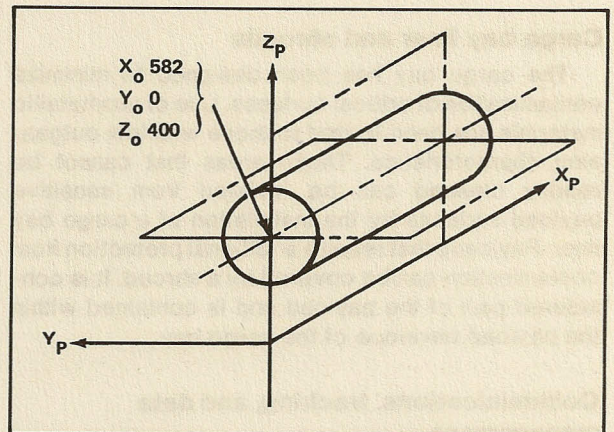

Figure 2-12.— Payload coordinates showing relationship to Orbiter station on each axis.

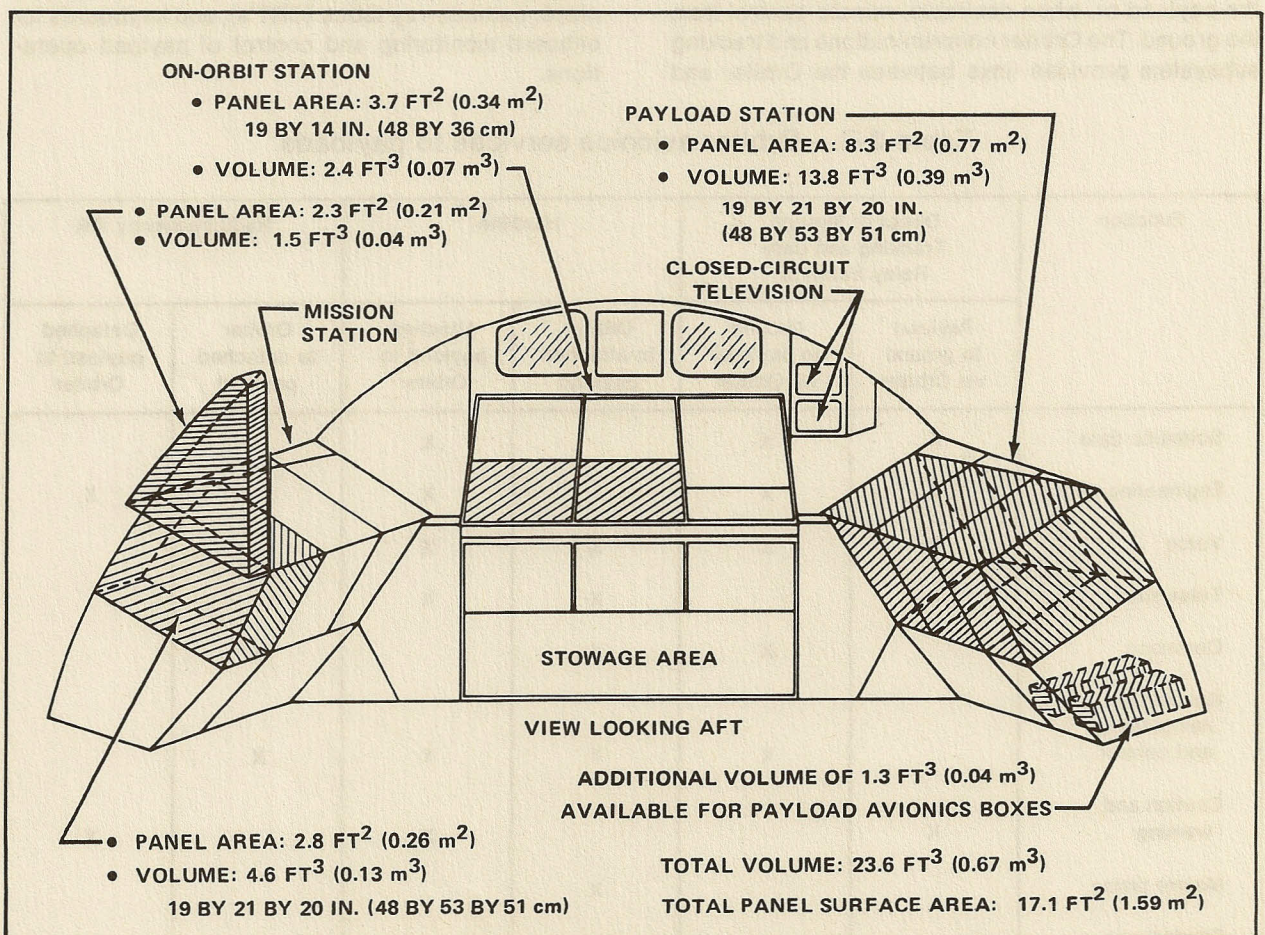

Figure 2-13.— Area available for payload equipment or controls in the Orbiter aft flight deck.

Cargo bay liner and shrouds

The cargo bay has been designed to minimize contamination of critical surfaces. Use of nonmetallic materials has been limited to those with low outgassing characteristics. Those areas that cannot be readily cleaned can be isolated from sensitive payload surfaces by the installation of a cargo bay liner. Payloads that require additional protection from contamination can be covered by a shroud. It is considered part of the payload and is contained within the payload envelope of the cargo bay.

Communications, tracking, and data management

The voice, television, and data-handling capabilities of the Orbiter support onboard control of the payload or, when desirable, remote control from the ground. The Orbiter communications and tracking subsystem provides links between the Orbiter and

the payload. It also transfers payload telemetry, uplink data commands, and voice signals to and from the space networks. The provisions in the Orbiter for communications, tracking, and data management are flexible enough to accommodate most payloads.

Links through the Orbiter are outlined in table 2-3. Communications capabilities, including those that bypass the Orbiter, are described in more detail in part 4.

The data processing and software subsystem of the Orbiter furnishes the onboard digital computation necessary to support payload management and handling. Functions in the computer are controlled by the mission specialist or a payload specialist through main memory loads from the tape memory. The stations in the Orbiter aft flight deck for payload management and handling are equipped with data displays, cathode-ray tubes (CRT's), and keyboards for onboard monitoring and control of payload operations.

Table 2-3.—Orbiter avionics services to payloads

Function	Direct or through Tracking and Data Relay Satellite		Hardline		Radiofrequency link	
	Payload to ground via Orbiter	Ground to payload via Orbiter	Orbiter to attached payload	Attached payload to Orbiter	Orbiter to detached payload	Detached payload to Orbiter
Scientific data	X	X		X		
Engineering data	X	X		X		X
Voice	X	X	X	X		
Television	X		X	X		
Command		X	X		X	
Guidance, navigation, and control		X	X	X	X	
Caution and warning	X			X		X
Master timing			X			
Rendezvous					X	X

Deployment and retrieval

The deployment and retrieval of payloads will be accomplished by use of the general-purpose remote manipulator system (RMS). The RMS is operated in both automatic and manual modes from the aft port window location of the Orbiter crew compartment by a payload specialist or a mission specialist using dedicated RMS controls and closed-circuit television. The system has three major operational elements: controls and displays, the manipulator arm, and the payload interface.

The RMS controls and displays provide the primary interface between the operator and the RMS. The manipulator arm (fig. 2-14) is a 50-foot (15-meter) long device attached at its shoulder to the port longeron of the Orbiter cargo bay. Its shoulder, elbow, and wrist joints are connected by carbon-composite arm booms and provide six degrees of freedom at the arm tip. Joint motion is provided by a motor module driving a high-precision high-reduction gear box. A second arm can be installed and controlled separately for payloads that require handling with two manipulators. Manipulators cannot be operated simultaneously. However, the capability exists to hold or lock one arm while operating the other. The interface of the RMS to the payload is the end effector mounted at the end of the RMS. Mounted on the payload is a grapple fixture that mates with the end effector.

Other functions of the RMS provided on orbit include the following.

1. Inspection—Free-flying payloads or payloads in the cargo bay can be inspected using the cameras on the RMS.
2. Mapping—The RMS, using automatic trajectories, can move payloads for sensing and mapping of the Orbiter environment.
3. Construction—The RMS can support space construction from the Orbiter.
4. Payload servicing—Using the end effectors, the RMS may perform remote payload servicing including module interchange.
5. Spacelab support—The RMS can manipulate equipment on Spacelab pallets and can deploy and retrieve Spacelab payloads.
6. EVA support—With a special-purpose end effector, the RMS can translate EVA crewmen and can carry equipment for activities such as servicing and construction.
7. Solar power—The RMS may deploy and maneuver solar-array systems to increase power and mission life of the Orbiter.

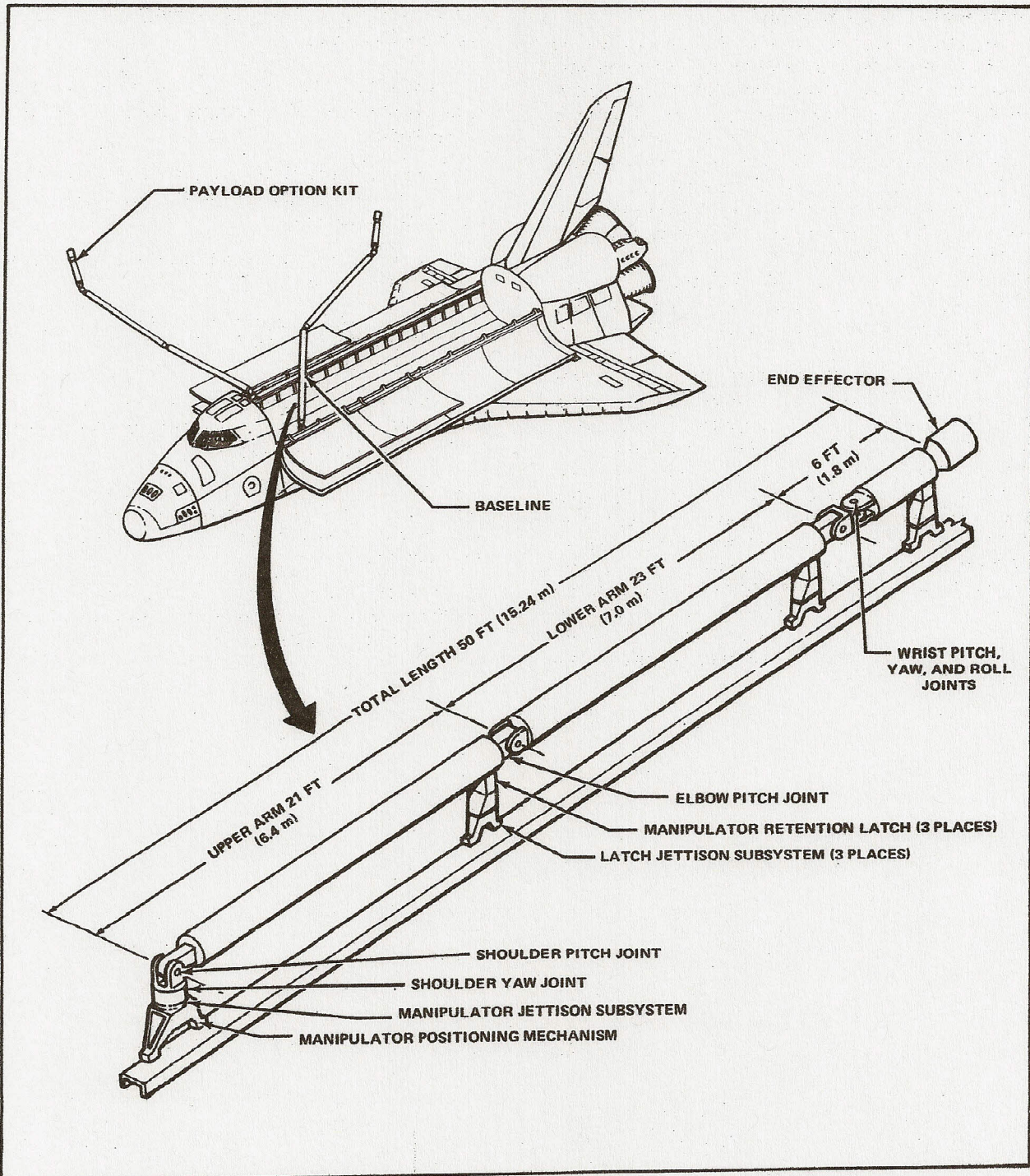

Figure 2-14.— Manipulator arm assembly.

Structural interfaces

Numerous attachment points along the sides and bottom of the cargo bay provide structural interfaces in a multitude of combinations to accommodate payloads. Thirteen primary attachment points along the sides accept X- and Z-axis loads. Twelve positions along the keel take lateral loads. Vernier locations are provided on each bridge fitting.

The fittings are designed to be adjusted to specific payload weight, volume, and center-of-gravity distributions in the bay. The fittings to attach payloads to the bridge fittings are standardized to minimize payload changeout operations.

Electrical interfaces

Electrical power is provided to the payload from three fuel cells that use cryogenically stored hydrogen and oxygen reactants. The electrical power requirements of a payload during a flight will vary. During the 10-minute launch-to-orbit and the 30-minute deorbit-to-landing phases (when most of the experiment hardware is on standby or turned off), 1000 watts average to 1500 watts peak are available from the Orbiter. In orbit, as much as 7000 watts average to 12 000 watts peak can be provided to the cargo.

For the usual 7-day flight, a minimum of 50 kilowatt-hours (180 megajoules) of electrical energy is available to payloads. If more energy is needed, flight kits can be added as required by the flight plan. Each kit contains enough consumables to provide 840 kilowatt-hours (3024 megajoules). These are charged to the payload mass and volume.

Each of three fuel cell powerplants provides 2 kilowatts minimum and 7 kilowatts continuous, with a 12-kilowatt peak of 15 minutes duration every 3 hours. For additional details about electrical power, refer to JSC-07700, Volume XIV.

Power extension package

The power extension package (PEP) (fig. 2-15) is being designed to provide increased power and duration capability for future Orbiter missions. The PEP consists of a deployed solar array and the power regulation, control, and interface equipment to allow the augmentation of the cryogen-fed Orbiter fuel cell power system.

The array deployment assembly (ADA) is deployed from the Orbiter by the RMS. The solar-array wings are then extended and oriented toward the Sun. The power generated by the array is carried by the RMS power cables into the cargo bay and pro-

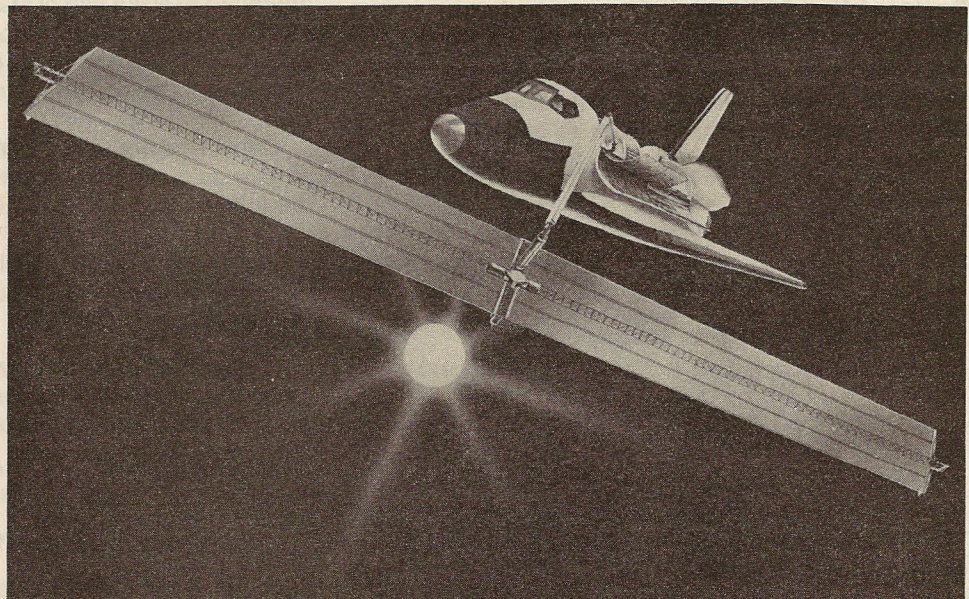

Figure 2-15.— Shuttle power extension package.

cessed and distributed by the power regulation control assembly (PRCA) to the Orbiter load buses. Use of the PEP reduces fuel cell cryogen consumption and thus increases mission duration capability. After the mission is completed, the array is retracted and the ADA is stored in the Orbiter for return to Earth.

Environmental control

Cooling services are provided to payloads by the Orbiter. Prelaunch and postlanding thermal control is provided by ground support systems. In orbit, the primary Orbiter heat rejection is accomplished by radiators on the cargo bay doors. A water flash evaporator is used to supplement the radiator cooling. During ascent and descent, when the cargo bay doors are closed and the radiators are ineffective, cooling is provided by the water boilers. The payload heat exchanger is designed so either water or Freon 21 can be selected as a cooling fluid, according to the needs of the payload. The payload side of the heat exchanger has two coolant passages; either or both can be used. Coolant is provided to the payload at 40° to 45° F (278 to 280 K). Fluid circulation through the payload side of the heat exchanger must be supplied as part of the payload.

Air-cooling capability exists for payload equipment mounted in the aft flight deck.

Optional flight kits

Flight kits that provide special or extended services for payloads can be added when required. They are designed to be quickly installed and easily removed. The major flight kits are as follows.

- Oxygen and hydrogen for fuel cell usage to generate electrical energy
- Life support for extended missions
- Added propellant tanks for special on-orbit maneuvers
- Airlocks and transfer tunnels
- Additional radiator panels for increased heat rejection
- Additional storage tanks

These flight kits are considered part of the payload and, as such, are charged to the payload weight and volume allocation. The most significant payload weight increase results from the additional energy kits. The extra tanks may result in a significant volume penalty as well.

Extravehicular activity

The capability for EVA is available on every Space Shuttle flight. Payload EVA falls into three categories: EVA planned before launch in order to complete a mission objective; EVA unscheduled but decided on during a flight in order to achieve payload operation success or to advance overall mission accomplishments; or EVA involving contingency measures necessary to move payload items out of the way of the cargo bay doors.

The equipment and consumables required for unscheduled and contingency EVA's are included on every Orbiter flight. Planned payload EVA is a user option.

Planned EVA can provide sensible, reliable, and cost-effective servicing operations for payloads. It gives the user the options of orbital equipment maintenance, repair, or replacement without the need to return the payload to Earth or, in the worst case, to abandon it in space. Therefore, the EVA capability can help maximize scientific return.

All EVA operations will be developed using the capabilities, requirements, definitions, and specifications set forth in Shuttle EVA Description and Design Criteria (JSC-10615).

Standard tools, tethers, restraints, and portable work stations for EVA are part of the Orbiter baseline support equipment inventory. The user is encouraged to make use of standard EVA support hardware whenever possible to minimize crew training, operational requirements, and cost. Any payload-unique tools or equipment must be furnished by the user.

Crewmembers using extravehicular mobility units (space suits and life support systems) can perform the following typical tasks (fig. 2-16).

- Inspection, photography, and possible manual override of vehicle and payload systems, mechanisms, and components
- Installation, removal, or transfer of film cassettes, material samples, protective covers, instrumentation, and launch or entry tiedowns
- Operation of equipment, including tools, cameras, and cleaning devices
- Cleaning of optical surfaces
- Connection, disconnection, and storage of fluid and electrical umbilicals

- Repair, replacement, calibration, and inspection of modular equipment and instrumentation of the spacecraft or payloads

- Deployment, retraction, and repositioning of antennas, booms, and solar panels

- Attachment and release of crew and equipment restraints

- Performance of experiments

- Cargo transfer

These EVA applications make it possible to demechanize operational tasks and thereby reduce design complexity (automation), simplify testing and quality assurance programs, lower manufacturing costs, and improve the probability of success. Given adequate restraints, adequate working volume, and compatible man/machine interfaces, EVA crewmembers can accomplish almost any task designed for manned operation on the ground.

Additional EVA capability is provided by the manned maneuvering unit, a propulsive backpack device (using a low-thrust, dry, cold gaseous nitrogen propellant) that enables a crewmember to reach areas beyond the cargo bay. The unit has a six-degree-of-freedom control authority, automatic attitude-hold capability, and electrical outlets for such ancillary equipment as power tools, a portable light, cameras, and instrument monitoring devices. Because the unit need not be secured to the Orbiter, the crewmember can use it to "fly" unencumbered to berthed or free-flying spacecraft work areas, to transport cargo of moderate size such as might be required for spacecraft servicing on orbit, and to retrieve small, free-flying payloads that may be sensitive to Orbiter thruster perturbation and contamination (the unit's own propellant causes minimal disturbances with no adverse contamination).

The manned maneuvering unit is normally carried only on those missions having requirements for it.

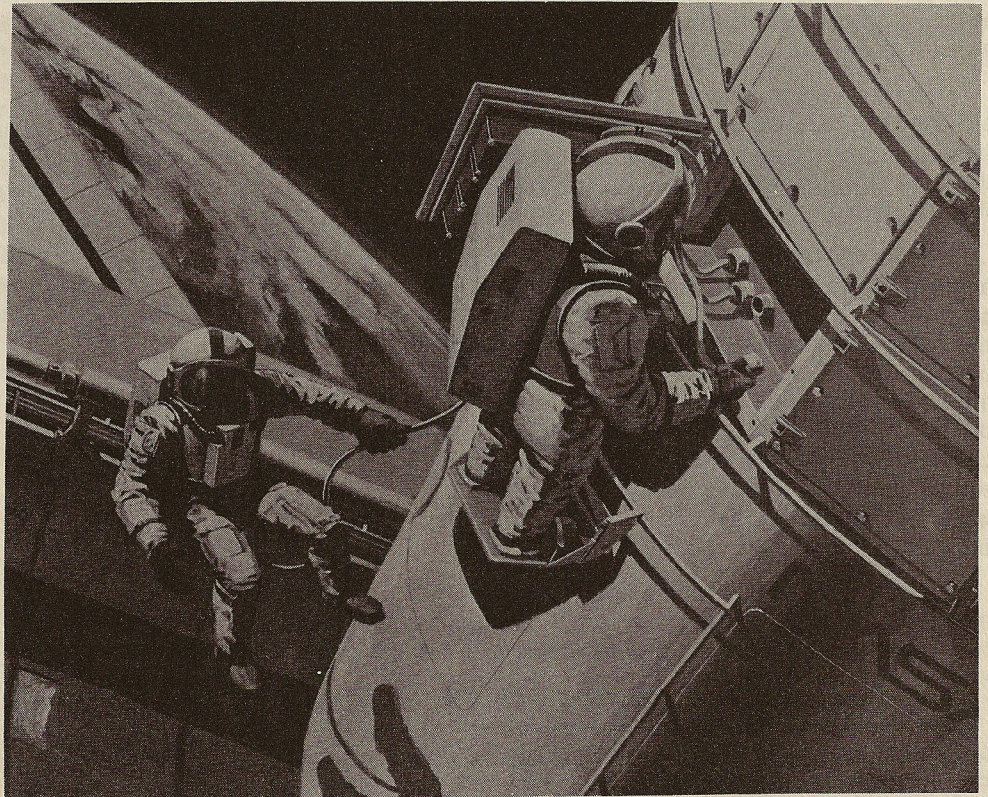

Figure 2-16.— Crewmembers performing extravehicular activity in support of a payload.

The following general constraints should be considered in early planning if a payload is expected to require EVA. These limitations are general in nature and, in certain circumstances, variations may be possible.

- EVA operations are normally performed by two EVA-trained crewmembers; however, one-man EVA is also possible.

- Planned EVA periods should not exceed one 6-hour duration per day (excluding the time required for preparation and post-EVA activities); this does not preclude multiple shorter EVA's.

- EVA may be conducted during both light and dark periods.

- EVA will not be constrained to ground communications periods.

- An EVA egress path into the cargo bay, 4 feet (1.2 meters) minimum length, must be available adjacent to the airlock outside hatch; payloads that infringe into this area must be capable of being jettisoned to allow for contingency EVA operations.

- The size of the airlock, tunnel adapter, and associated hatches limits the external dimensions of packages that can be transferred to or from payloads to 18 by 18 by 50 inches (45.7 by 45.7 by 127 centimeters).

- Payloads requiring EVA operations must have access corridors and work areas large enough to allow the EVA crewmember to perform the required tasks safely and with adequate mobility. A translation path requiring the EVA crewmember to use mobility aids must be at least 43 inches (109 centimeters) in diameter; additional volume is required when abrupt changes in the direction of travel are required. Tasks requiring extensive body and arm manipulation require a working envelope 48 inches (122 centimeters) in diameter.

- EVA support equipment, loose payload components, and umbilicals must be firmly secured or tethered at all times during EVA operations to prevent loss, damage, or entanglement.

- Payload components susceptible to inadvertent physical damage or contamination by an EVA crewmember should be protected or located away from EVA work stations and translation paths.

- EVA is an acceptable mode of operation in low-Earth-orbit radiation zones if flight planning constraints inhibit planning around them.

Payload carrier aircraft

Although it is not considered an STS element, the Super Guppy aircraft (fig. 2-17) is primarily intended for the transport of STS payloads that either are too large for shipment by conventional means or require special handling. Examples are outsized cargo such as large Space Shuttle test articles, components of Space Shuttle systems, flightcrew training modules, and Space Shuttle payloads and equipment that require a very large aircraft for transport.

The Super Guppy is powered by four turboprop engines and can accommodate a maximum payload of 40 000 pounds (18 000 kilograms), including cargo pallets and adapters. The specifications/performance of the Super Guppy are as follows:

Maximum takeoff weight	175 000 lb (79 400 kg)
Maximum landing weight	162 000 lb (73 500 kg)
Empty weight	110 091 lb (49 936 kg)
Maximum zero fuel weight	152 000 lb (68 950 kg)
Empty operating weight	111 221 lb (50 449 kg)
Total fuel capacity	6580 lb (2985 kg)
Cruise speed	285 mph (459 km/h)
Block hour speed	243 mph (391 km/h)
Range	560 mi (900 km) with 40 000-lb (18 000-kg) cargo and 45-minute fuel reserve

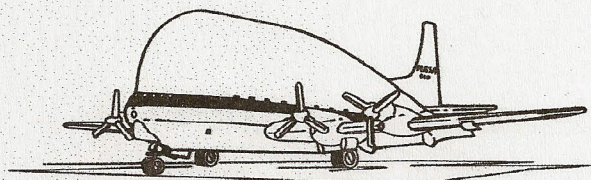

Figure 2-17.— Super Guppy.

SAFETY AND INTERFACE VERIFICATION

All payloads using the Space Transportation System will be subject to a uniform set of basic safety and interface verification requirements. The verification system is designed so that the user will not need to duplicate or repeat verifications already made.

Payload safety requirements

The NASA STS safety requirements are defined in Safety Policy and Requirements for Payloads Using the Space Transportation System (NHB 1700.7A). These requirements are applicable to all payloads. The Payload Safety Guidelines Handbook (JSC-11123) has been developed to assist the user in selecting design options to eliminate hazards.

The intent of the safety policy is to minimize active involvement of the STS, both at the design level and during actual flight, without compromising safety. The method of implementing payload safety is defined in Implementation Procedures for STS Payloads Safety Requirements (JSC-13830).

The STS safety policy requires that the basic payload design ensure the elimination or control of any hazard to the Orbiter, crew, or other payloads.

The payload supplier is responsible for ensuring the safety of any hardware proposed for use in the STS.

Safe payload operation with a minimum dependence on the Orbiter and its crew is an STS goal. The payload supplier must identify all potentially hazardous operating sequences. Hazardous situations that require a rapid response should, if possible, be corrected by automatic systems that are part of the payload.

The STS provides a limited capability for display and subsequent command of payload parameters. Therefore, use of this capability should be limited to safety conditions that cannot or logically should not be handled by design or operational provisions. The status of safing systems and the indication of anomalous conditions occurring within a payload that do not meet these criteria should be handled in the same manner as general payload telemetry and command and control; i.e., by ground control or through the Orbiter payload station.

The basic safety approach applied to attached payloads should also be used for those that are to be deployed and retrieved. Payloads to be retrieved

must provide verification of safe status while still at a safe distance.

The payload design must preclude propagation of failures from the payload to the outside environment. In addition, safety-critical redundant subsystems must be arranged to minimize the possibility of the failure of one affecting the other.

Previous manned space flight standards for flammability, offgassing, and odor of materials have been reduced somewhat for payloads carried outside the Orbiter cabin (either in other pressurized areas or in the open cargo bay). The Orbiter cabin provides smoke detection, fire suppression, and atmospheric scrubbing, which mitigate the hazards from flammability and offgassing.

The major goal is to design the payload for minimum hazard by including damage control, containment, and isolation of potential hazards. Hazards that cannot be eliminated by design must be reduced as much as possible and made controllable through the use of safety devices as part of the system, subsystem, or equipment.

Payload interface verification requirements

Testing and interface verification of flight hardware and flight software is greatly simplified by the reuse of proven systems (Spacelab, Long Duration Exposure Facility, or Multimission Modular Spacecraft) or by the flight of identical expendable items (inertial upper stage and payload assist module). The users will not need to repeat the verification process that the standard flight systems must undergo as part of their development. This will significantly reduce the time and cost of interface verification for the user.

The payload accommodation interfaces for the Space Shuttle system have been defined in Space Shuttle System Payload Accommodations (JSC-07700, Vol. XIV). Interface verification requirements are defined in Payload Interface Verification Requirements (JSC-14046). The latter document requires that each interface with the STS have a method and location of the interface verification identified before the payload is installed in the Orbiter.

Users of the standard payload carriers will assess their payloads to determine whether new or unique configurations require verification before flight. This

assessment and necessary verification will be accomplished in conjunction with the STS operations organization.

Few or no additional verification requirements are anticipated for payloads that are reflown; however, some assessment of the payload should be made to ensure that configuration changes to the payload or cargo do not create a new interface that would require preflight verification.

The term "payload" describes any item provided by the user having a direct physical or functional interface with the Space Shuttle system.

A payload interface verification summary shall be submitted to JSC for review and concurrence of the verification methods for safety-critical interfaces. When necessary, the verification methods for the safety-critical interfaces will be negotiated with the responsible payload organization to achieve an acceptable verification that will ensure a safe system.

These safety-critical interface verification methods shall be subject to appropriate management control with the Space Transportation System.

Equipment suitable for interface verification testing is available at the launch site. The cargo integration test equipment (CITE) at KSC is capable of simultaneous payload interface testing for mixed cargoes and cargo-to-Orbiter testing.

At the completion of the interface verification process but before the payload is installed in the Orbiter, a certificate of compliance confirming interface compatibility shall be prepared by the using payload organization and submitted to the Shuttle system organization. The certificate of compliance documentation shall include all interface verification requirement waivers, noncompliances, and deferrals; this documentation will become a permanent part of the payload data package.

SPACELAB

Spacelab is a versatile, general-purpose orbiting laboratory for manned and automated activities in near-Earth orbit. The primary program objective is to provide the scientific community with easy, economical access to space. Involvement of ground-based scientific personnel in direct planning and flight support is an integral part of this program.

The Spacelab, built in Europe with European funds to joint U.S. and European requirements, is carried by the Space Shuttle and remains attached to the Orbiter during all phases of the mission. The overall physical characteristics of most importance to users of the Spacelab are summarized here.¹ All accommodations are described in more detail in the Spacelab Payload Accommodation Handbook (ESA SLP/2104).

¹Spacelab has, in general, been fabricated and currently is in the checkout and test stage of the program prior to delivery to NASA. As a result, the system characteristics described in this section may change somewhat as testing progresses.

The Spacelab consists of module and pallet sections used in various configurations to suit the needs of a particular mission (figs. 2-18 and 2-19). The pressurized module, accessible from the Orbiter cabin through a transfer tunnel, provides a shirt-sleeve working environment. The module consists of one or two cylindrical segments, each 13.3 feet (4.1 meters) in diameter and 8.6 feet (2.6 meters) long, and two end cones. The forward end cone is truncated at the diameter required to interface with the crew transfer tunnel. Spacelab subsystem equipment and experiment equipment are located in the core segment, leaving about 60 percent of the volume available for experiments; all the experiment segment is available for experiments.

Pallets accommodate experiment equipment for direct exposure to space. Each standard pallet segment is 9.8 feet (3 meters) long. Two or three segments can be connected to form a single pallet train, supported by one set of retention fittings. If no module is used, a cylindrical "igloo," mounted on the end of the forward pallet, provides a controlled, pres-

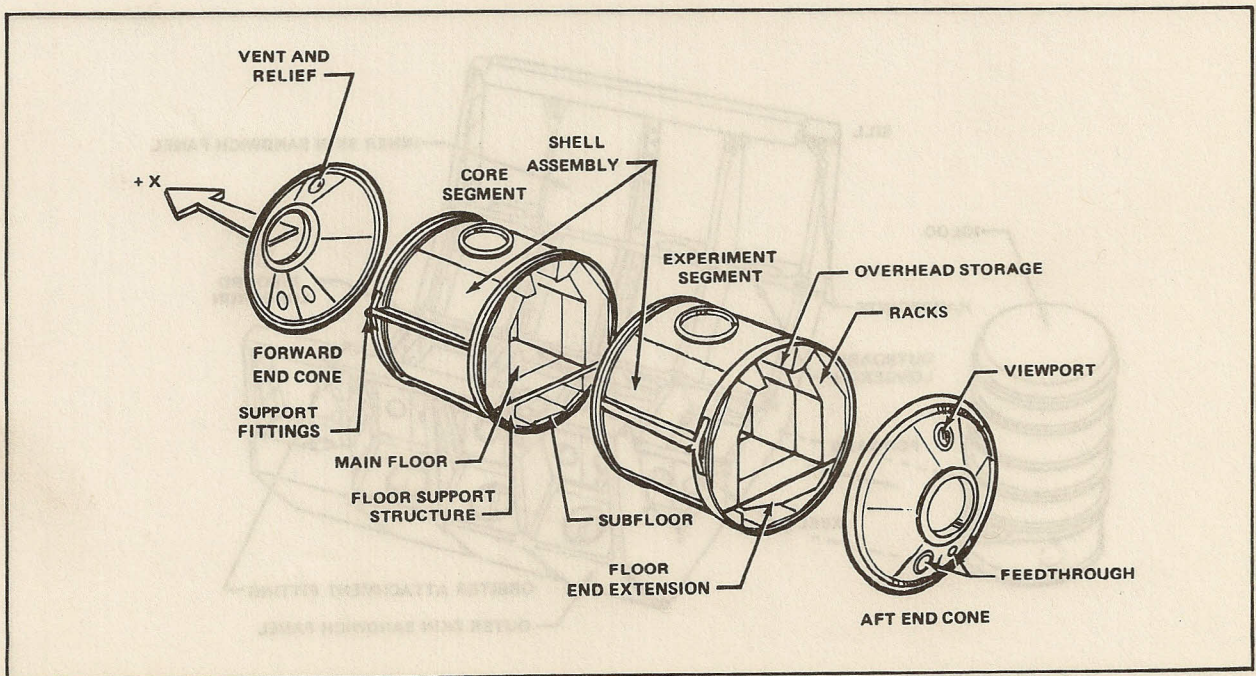

Figure 2-18.— Overall configuration of the Spacelab module showing both the core and experiment segments.

surized environment for Spacelab subsystems normally carried in the core segment. The Spacelab module and the igloo both contain experiment capabilities that include computers, input/output (I/O) units, and remote acquisition units (RAU's).

In addition to the basic hardware inventory, the Spacelab program provides a selection of mission-dependent equipment that can be flown according to

the requirements of a particular mission.

When the module is used, primary control of scientific equipment will be from the module itself. A Payload Operations Control Center (POCC) on the ground will function in a support and advisory capacity to onboard activity. In a pallet-only configuration, equipment is operated remotely from the Orbiter aft flight deck and/or from the POCC.

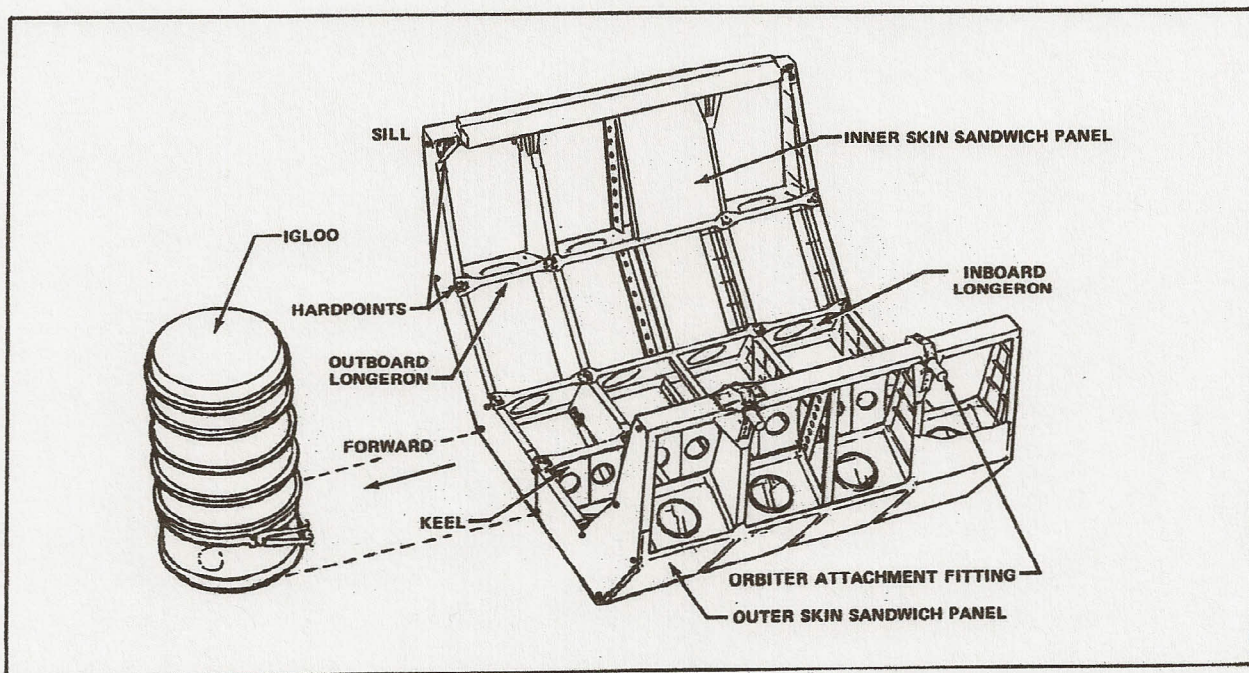

Figure 2-19.— Spacelab pallet segment and igloo.

Basic configurations

Eight basic flight configurations (fig. 2-20) have been designed to meet most user needs. The Spacelab hardware, however, allows other flight configurations by combining appropriate hardware elements. These flight configurations must be within the center-of-gravity (c.g.) and operational envelopes.

1. Long module. The long module consists of core and experiment segments. This configuration, without a pallet, provides the largest pressurized volume for Spacelab payloads with 784 cubic feet (22 cubic meters) available for payload equipment.

2. Long module/one pallet. In this configuration, 184.1 square feet (17.1 square meters) of surface mounting area is available on the pallet. The pallet length is 9.8 feet (3 meters). (In exceptional instances, payloads can overhang at both ends of a pallet.) The inside dimensions of the module are given in the description of the long module.

3. Long module/two pallets. This configuration increases the space-exposed mounting area by connecting two pallets in a train. The two pallets provide 368.1 square feet (34.2 square meters) of mounting area and a pallet length of 19.3 feet (5.9 meters).

4. Short module/two pallets. This pallet configuration is the same as the one described previously except that a short module has replaced the long one. This configuration also provides a pallet length of 19.3 feet (5.9 meters).

5. Short module/three pallets. This configuration offers the largest pallet area if both a module and a pallet are required for a single mission. The usable pallet length is 29.1 feet (8.9 meters) with a mounting surface of 552.2 square feet (51.3 square meters). The volume available to payload equipment inside the short module is 268.4 cubic feet (7.6 cubic meters).

6. Pallets only, independently suspended. This configuration consists of three independently suspended pallet segments spread along the length of the cargo bay. The total pallet length is 28.3 feet (8.6 meters). The total surface mounting area is 552.2 square feet (51.3 square meters).

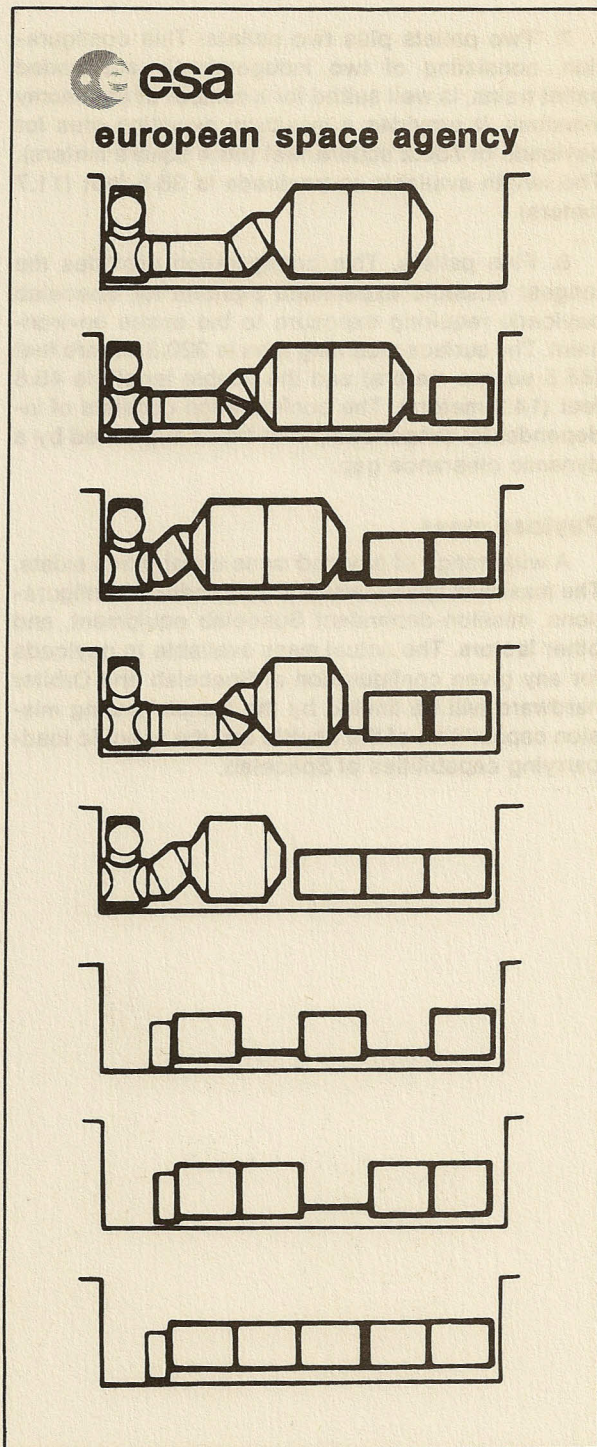

Figure 2-20.— Basic Spacelab flight configurations.

7. Two pallets plus two pallets. This configuration, consisting of two independently suspended pallet trains, is well suited for a number of astronomy missions. It provides a maximum mounting area for payloads of 736.2 square feet (68.4 square meters). The length available to payloads is 38.5 feet (11.7 meters).

8. Five pallets. This configuration provides the longest possible experiment platform for Spacelab payloads requiring exposure to the space environment. The surface mounting area is 920.3 square feet (85.5 square meters) and the usable length is 48.8 feet (14.9 meters). The configuration consists of independently suspended pallet trains separated by a dynamic clearance gap.

Payload mass

A wide range of payload mass capabilities exists. The maximum space available depends on configurations, mission-dependent Spacelab equipment, and other factors. The actual mass available to payloads for any given configuration of Spacelab and Orbiter hardware will be limited by the launch/landing mission capabilities of the Shuttle and the specific load-carrying capabilities of Spacelab.







The mass available to Spacelab and its payloads is limited by the maximum Orbiter landing mass (although for a wide range of orbits, the Orbiter load-carrying capability is considerably greater at launch than at landing).

Each of the possible configurations will have a different total mass. The control masses listed in table 2-4 represent the maximum mission-dependent equipment that can be flown in each configuration. The total mass available for both payloads and mission-dependent equipment is listed for each configuration. However, the actual mass capability is further limited by structural limitations of various components. Additional localized constraints exist, such as the mass-supporting capabilities of racks and hardpoints.

Center of gravity

The Orbiter imposes center-of-gravity constraints on the Spacelab. To establish the overall center of gravity of a combined Spacelab and its payload, the masses and centers of gravity for individual hardware and consumable items must be combined according to the requirements of a particular mission.

Table 2-4.—Mass allocation to Spacelab and payloads

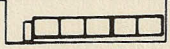
Configuration	Total mission-independent Spacelab mass, lb (kg)	Mass of 100 percent Spacelab mission-dependent equipment, lb (kg)	Mass available to payload and mission-dependent equipment, lb (kg)
	14 921 (6768)	3120 (1415)	13 702 (6215)
	17 434 (7908)	3549 (1610)	13 660 (6196)
	18 602 (8438)	3660 (1660)	12 258 (5560)
	16 486 (7478)	2238 (1015)	14 363 (6515)
	17 654 (8008)	2348 (1065)	13 261 (6015)
	10 029 (4549)	1268 (575)	20 668 (9375)
	10 657 (4834)	1345 (610)	20 084 (9110)
	11 980 (5434)	1455 (660)	18 320 (8310)

Module segments

Modules for all flight configurations contain a basic internal arrangement of subsystem equipment; the main difference is the volume available for experiment equipment installation. Although subsystem equipment is located in the core segment, about 60 percent of the volume is available for experiments.

The following list is representative of the basic Spacelab experiment equipment.

- Experiment racks
- Experiment computer
- Scientific airlock
- Cold plates
- RAU's
- Data display unit
- High-rate data recorder
- High-rate multiplexer

All equipment is described in more detail in the Spacelab Payload Accommodation Handbook.

The module interior is sized and shaped to allow optimum task performance by crewmembers in a weightless environment (fig. 2-21). The module can accommodate as many as three payload specialists. For shift overlap, as many as four can be accommodated for 1 hour. The cabin air temperature is maintained between 64° and 81° F (291 and 300 K).

Foot restraints, handholds, and mobility aids are provided throughout the Spacelab so that crewmembers can perform all tasks safely, efficiently, and in the most favorable body position. The basic foot restraint system is identical in the Orbiter and the Spacelab.

A workbench in the core segment (fig. 2-22) is intended to support general work activities rather than those associated with a unique experiment. One electrical outlet (28 V dc, 100 watts) is available to support experiment equipment.

The transfer tunnel connecting the Spacelab module and the Orbiter enables crew and equipment transfer in a shirt-sleeve environment. The tunnel has

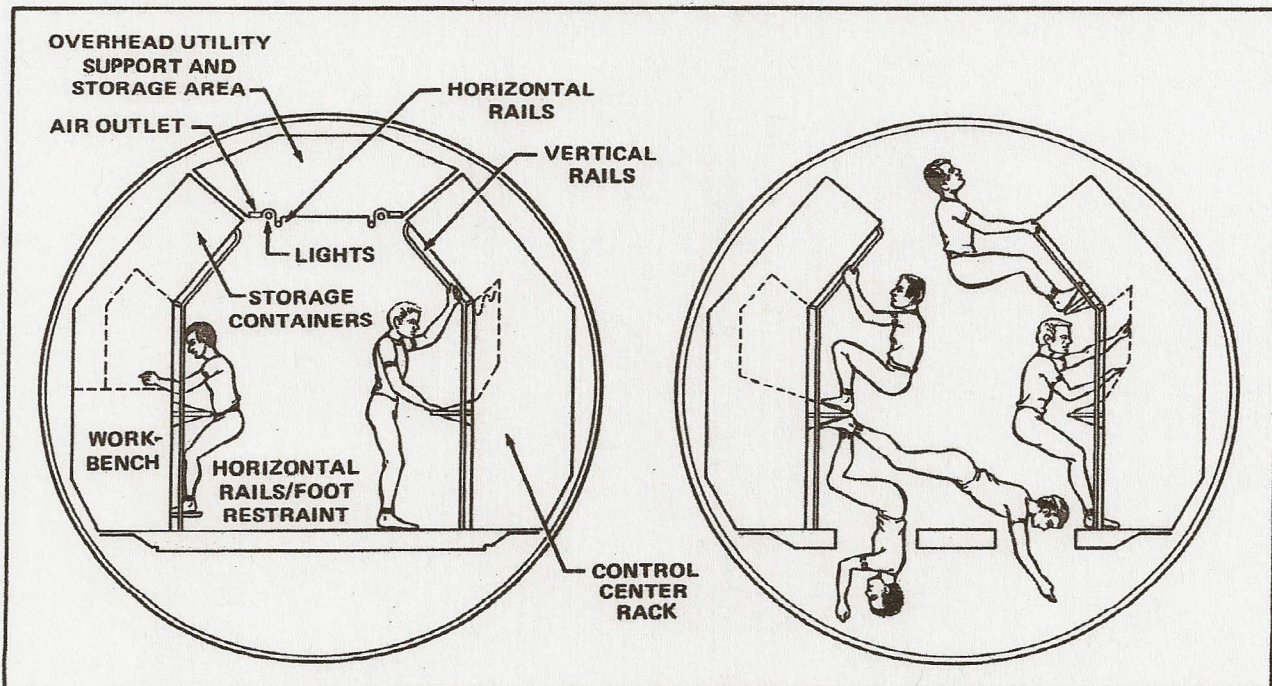

Figure 2-21.— Primary crew working area (looking forward) and examples of the many possible working positions.

a minimum of about 3.3 feet (1 meter) clear diameter, sufficient for a box with dimensions of 1.84 by 1.84 by 4.17 feet (0.56 by 0.56 by 1.27 meters) and a crewmember (including one equipped for EVA). The tunnel can also be used for ground access to the Spacelab while it is still horizontal.

For EVA, Spacelab provisions allow a crewmember in a pressure suit to move through the EVA hatch

(the Orbiter personnel airlock in the Spacelab tunnel adapter or the docking module, depending on the mission configuration), up the end cone of the module, over the module, down the aft cone, and along the pallet. The size of the airlock and associated hatches limits the external dimensions of a package that can be transferred to payloads.

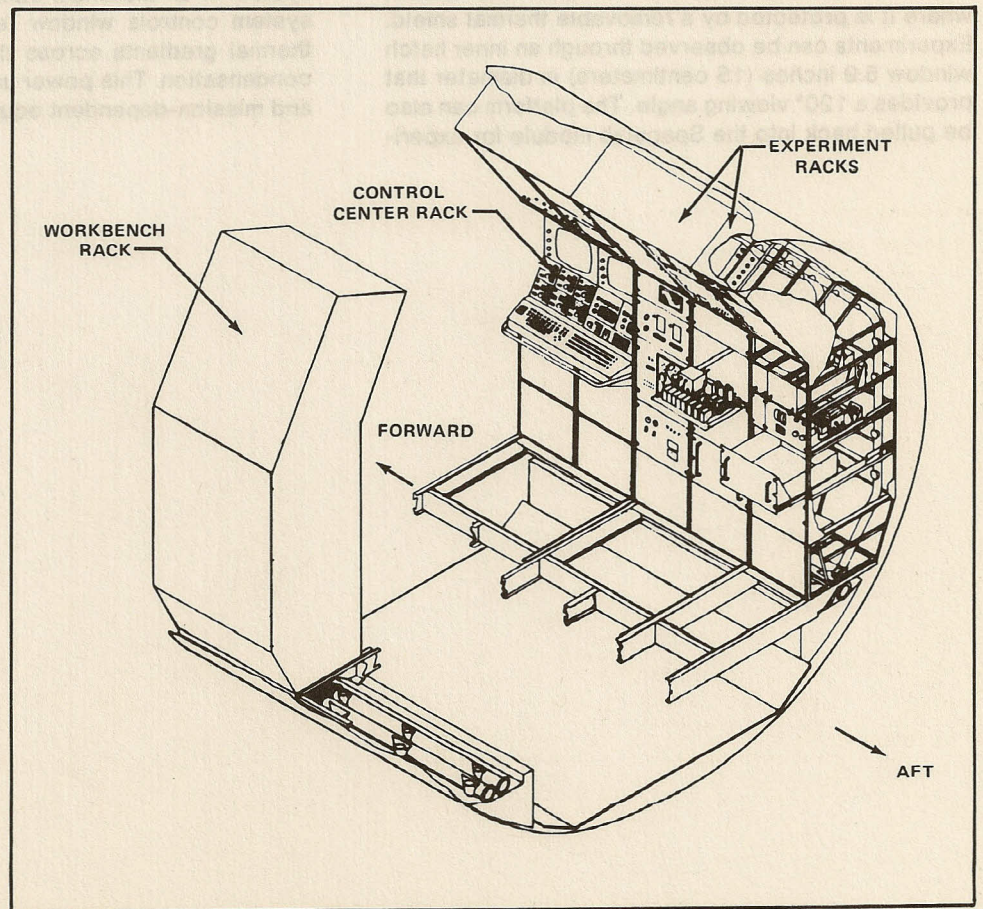

Figure 2-22.— Spacelab core segment cutaway view (starboard).

Common payload support equipment

The common payload support equipment (mission-dependent items) includes a top airlock and an optical window/viewport assembly. Each can be flown as needed. A flanged cutout of 51.18 inches (130 centimeters) internal diameter is left in the top of each cylindrical segment of the module for installation of the airlock or optical window/viewport. Both openings are sealed with coverplates if not needed.

Airlock for experiments

The scientific airlock enables experiments to be exposed to a space environment. Experiments are mounted on a sliding platform parallel to the airlock axis. This platform can be extended into space, where it is protected by a removable thermal shield. Experiments can be observed through an inner hatch window 5.9 inches (15 centimeters) in diameter that provides a 120° viewing angle. The platform can also be pulled back into the Spacelab module for experi-

ment mounting and checking (both on orbit and on the ground). The inner hatch can be completely detached for payload installation and access. All controls are manual.

Experiment data handling and control can be performed either by the command and data management subsystem (by use of an experiment remote acquisition unit mounted on the airlock platform) or by hard-wired lines through the airlock shell to the payload equipment in the module.

Optical window and viewport

The optical window consists of a single rectangular pane of BK-7 glass measuring 16.14 by 21.65 inches (41 by 55 centimeters) and having a thickness of 1.61 inches (4.1 centimeters). It is enclosed in a molded seal and supported by a flexible spring system in an aluminum frame. An automatic heating system controls window temperatures to minimize thermal gradients across the glass and to prevent condensation. This power use is charged to payload and mission-dependent equipment.

Pallet structure

The standard U-shaped pallet segments (fig. 2-23) are of aeronautic-type construction covered with aluminum panels. These panels can be used for mounting lightweight payload equipment. A series of hardpoints attached to the main structure of a pallet segment allows mounting of heavy payload items.

The pallet provides the following basic services:

- Subsystem and experiment electric power buses
 - Experiment power distribution boxes
 - Subsystem and experiment data buses
 - Subsystem RAU's and as many as four RAU's for experiments
 - Thermal insulation blankets
 - Cold plates and thermal capacitors
 - Plumbing (standard)
- Three computers
 - Two input/output units
 - A mass memory
 - Two subsystem RAU's
 - An emergency power box
 - An experiment and a subsystem inverter (each 400 hertz)
 - A power control box
 - A subsystem power distribution box
 - A remote amplifier and advisory box
 - A multiplexer
 - A subsystem interconnecting station

In a pallet-only configuration, the Spacelab subsystem equipment located in the module is installed in an igloo. The following list is representative of the igloo subsystem equipment.

On the ground, access to the igloo interior is made through a removable bulkhead.

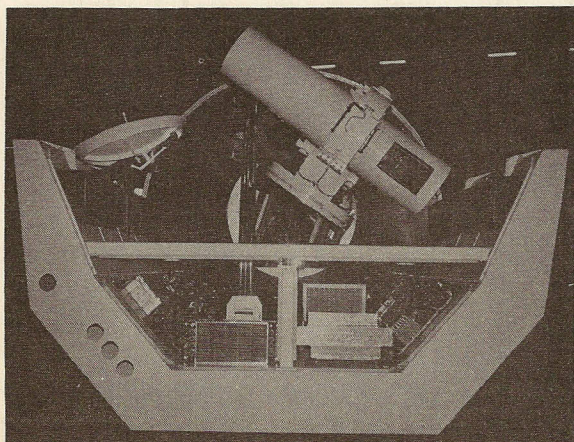

Figure 2-23.— Representative experiment mounted on a pallet.

7. Two pallets plus two pallets. This configuration, consisting of two independently suspended pallet trains, is well suited for a number of astronomy missions. It provides a maximum mounting area for payloads of 736.2 square feet (68.4 square meters). The length available to payloads is 38.5 feet (11.7 meters).

8. Five pallets. This configuration provides the longest possible experiment platform for Spacelab payloads requiring exposure to the space environment. The surface mounting area is 920.3 square feet (85.5 square meters) and the usable length is 48.8 feet (14.9 meters). The configuration consists of independently suspended pallet trains separated by a dynamic clearance gap.

Payload mass

A wide range of payload mass capabilities exists. The maximum space available depends on configurations, mission-dependent Spacelab equipment, and other factors. The actual mass available to payloads for any given configuration of Spacelab and Orbiter hardware will be limited by the launch/landing mission capabilities of the Shuttle and the specific load-carrying capabilities of Spacelab.





The mass available to Spacelab and its payloads is limited by the maximum Orbiter landing mass (although for a wide range of orbits, the Orbiter load-carrying capability is considerably greater at launch than at landing).

Each of the possible configurations will have a different total mass. The control masses listed in table 2-4 represent the maximum mission-dependent equipment that can be flown in each configuration. The total mass available for both payloads and mission-dependent equipment is listed for each configuration. However, the actual mass capability is further limited by structural limitations of various components. Additional localized constraints exist, such as the mass-supporting capabilities of racks and hardpoints.

Center of gravity

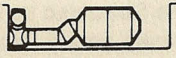
The Orbiter imposes center-of-gravity constraints on the Spacelab. To establish the overall center of gravity of a combined Spacelab and its payload, the masses and centers of gravity for individual hardware and consumable items must be combined according to the requirements of a particular mission.

Table 2-4.—Mass allocation to Spacelab and payloads

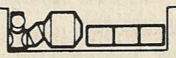
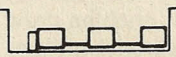
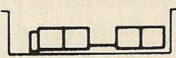
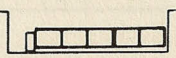
Configuration	Total mission-independent Spacelab mass, lb (kg)	Mass of 100 percent Spacelab mission-dependent equipment, lb (kg)	Mass available to payload and mission-dependent equipment, lb (kg)
	14 921 (6768)	3120 (1415)	13 702 (6215)
	17 434 (7908)	3549 (1610)	13 660 (6196)
	18 602 (8438)	3660 (1660)	12 258 (5560)
	16 486 (7478)	2238 (1015)	14 363 (6515)
	17 654 (8008)	2348 (1065)	13 261 (6015)
	10 029 (4549)	1268 (575)	20 668 (9375)
	10 657 (4834)	1345 (610)	20 084 (9110)
	11 980 (5434)	1455 (660)	18 320 (8310)

Module segments

Modules for all flight configurations contain a basic internal arrangement of subsystem equipment; the main difference is the volume available for experiment equipment installation. Although subsystem equipment is located in the core segment, about 60 percent of the volume is available for experiments.

The following list is representative of the basic Spacelab experiment equipment.

- Experiment racks
- Experiment computer
- Scientific airlock
- Cold plates
- RAU's
- Data display unit
- High-rate data recorder
- High-rate multiplexer

All equipment is described in more detail in the Spacelab Payload Accommodation Handbook.

The module interior is sized and shaped to allow optimum task performance by crewmembers in a weightless environment (fig. 2-21). The module can accommodate as many as three payload specialists. For shift overlap, as many as four can be accommodated for 1 hour. The cabin air temperature is maintained between 64° and 81° F (291 and 300 K).

Foot restraints, handholds, and mobility aids are provided throughout the Spacelab so that crewmembers can perform all tasks safely, efficiently, and in the most favorable body position. The basic foot restraint system is identical in the Orbiter and the Spacelab.

A workbench in the core segment (fig. 2-22) is intended to support general work activities rather than those associated with a unique experiment. One electrical outlet (28 V dc, 100 watts) is available to support experiment equipment.

The transfer tunnel connecting the Spacelab module and the Orbiter enables crew and equipment transfer in a shirt-sleeve environment. The tunnel has

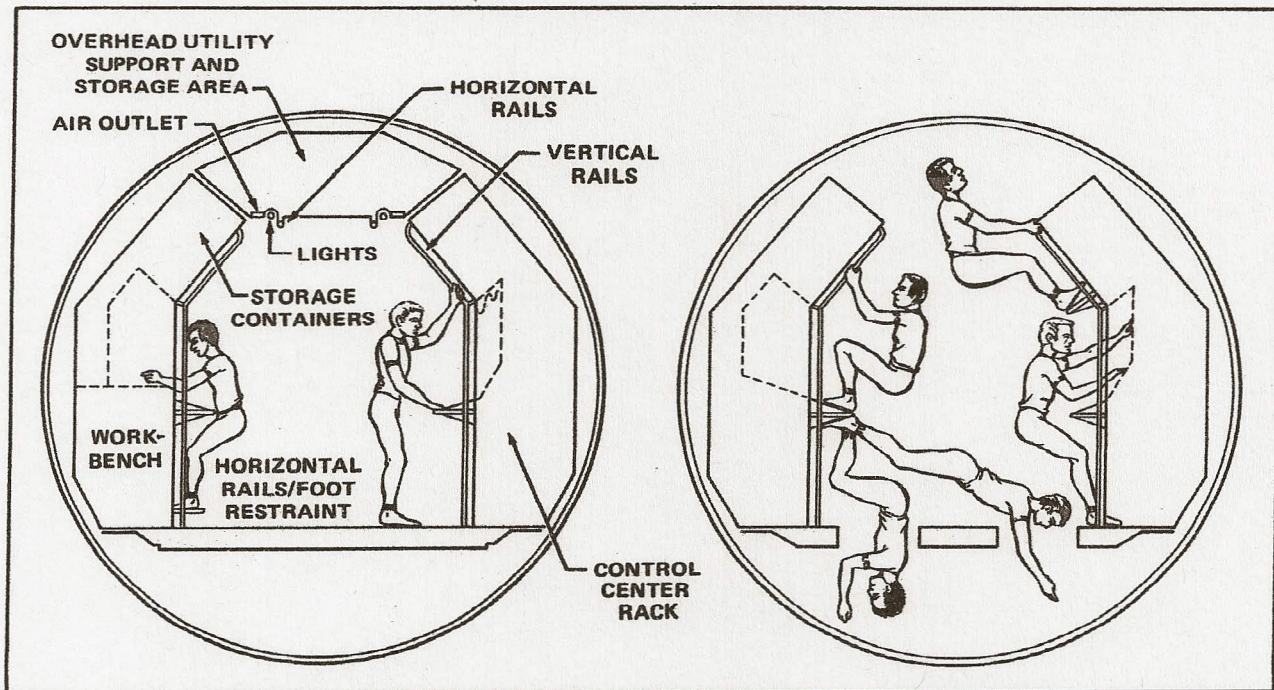

Figure 2-21.— Primary crew working area (looking forward) and examples of the many possible working positions.

a minimum of about 3.3 feet (1 meter) clear diameter, sufficient for a box with dimensions of 1.84 by 1.84 by 4.17 feet (0.56 by 0.56 by 1.27 meters) and a crewmember (including one equipped for EVA). The tunnel can also be used for ground access to the Spacelab while it is still horizontal.

For EVA, Spacelab provisions allow a crewmember in a pressure suit to move through the EVA hatch

(the Orbiter personnel airlock in the Spacelab tunnel adapter or the docking module, depending on the mission configuration), up the end cone of the module, over the module, down the aft cone, and along the pallet. The size of the airlock and associated hatches limits the external dimensions of a package that can be transferred to payloads.

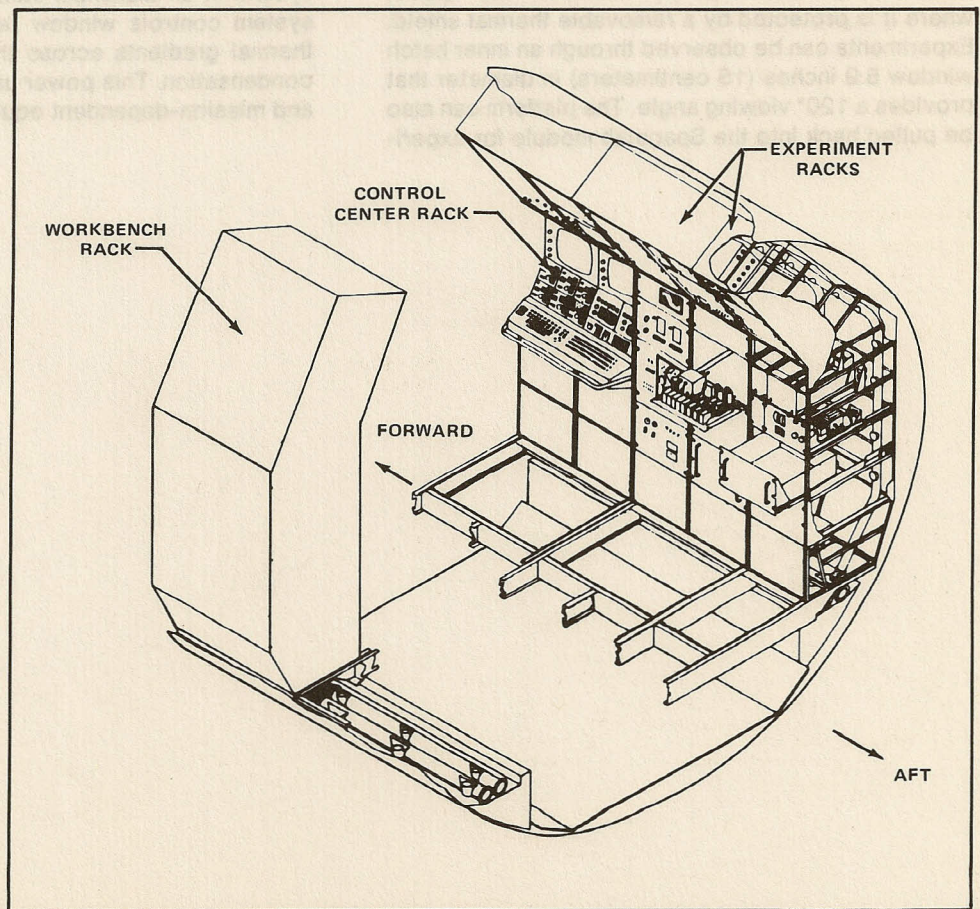

Figure 2-22.— Spacelab core segment cutaway view (starboard).

Common payload support equipment

The common payload support equipment (mission-dependent items) includes a top airlock and an optical window/viewport assembly. Each can be flown as needed. A flanged cutout of 51.18 inches (130 centimeters) internal diameter is left in the top of each cylindrical segment of the module for installation of the airlock or optical window/viewport. Both openings are sealed with coverplates if not needed.

Airlock for experiments

The scientific airlock enables experiments to be exposed to a space environment. Experiments are mounted on a sliding platform parallel to the airlock axis. This platform can be extended into space, where it is protected by a removable thermal shield. Experiments can be observed through an inner hatch window 5.9 inches (15 centimeters) in diameter that provides a 120° viewing angle. The platform can also be pulled back into the Spacelab module for experi-

ment mounting and checking (both on orbit and on the ground). The inner hatch can be completely detached for payload installation and access. All controls are manual.

Experiment data handling and control can be performed either by the command and data management subsystem (by use of an experiment remote acquisition unit mounted on the airlock platform) or by hard-wired lines through the airlock shell to the payload equipment in the module.

Optical window and viewport

The optical window consists of a single rectangular pane of BK-7 glass measuring 16.14 by 21.65 inches (41 by 55 centimeters) and having a thickness of 1.61 inches (4.1 centimeters). It is enclosed in a molded seal and supported by a flexible spring system in an aluminum frame. An automatic heating system controls window temperatures to minimize thermal gradients across the glass and to prevent condensation. This power use is charged to payload and mission-dependent equipment.

Pallet structure

The standard U-shaped pallet segments (fig. 2-23) are of aeronautic-type construction covered with aluminum panels. These panels can be used for mounting lightweight payload equipment. A series of hardpoints attached to the main structure of a pallet segment allows mounting of heavy payload items.

The pallet provides the following basic services:

- Subsystem and experiment electric power buses
- Experiment power distribution boxes
- Subsystem and experiment data buses
- Subsystem RAU's and as many as four RAU's for experiments
- Thermal insulation blankets
- Cold plates and thermal capacitors
- Plumbing (standard)

In a pallet-only configuration, the Spacelab subsystem equipment located in the module is installed in an igloo. The following list is representative of the igloo subsystem equipment.

- Three computers
- Two input/output units
- A mass memory
- Two subsystem RAU's
- An emergency power box
- An experiment and a subsystem inverter (each 400 hertz)
- A power control box
- A subsystem power distribution box
- A remote amplifier and advisory box
- A multiplexer
- A subsystem interconnecting station

On the ground, access to the igloo interior is made through a removable bulkhead.

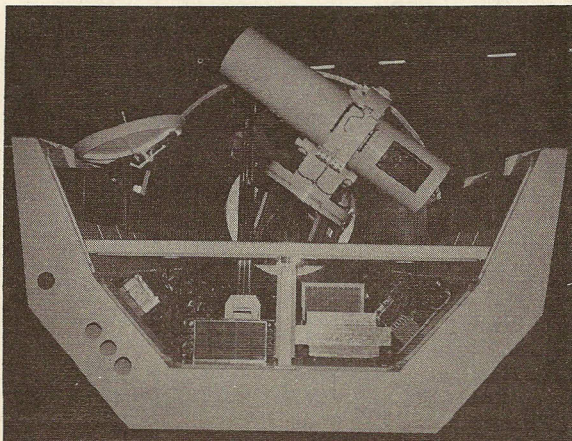

Figure 2-23.— Representative experiment mounted on a pallet.

Instrument pointing system





An instrument pointing system (IPS) is available and can provide precision pointing for payloads that require greater pointing accuracy and stability than is provided by the Orbiter. The IPS can accommodate a wide range of payload instruments of different sizes and weights from 440 to 4410 pounds (200 to 2000 kilograms).

Payload resources summary

Tables 2-5 to 2-7 summarize the principal resources available to payloads using the Spacelab. All accommodations are described in more detail in the Spacelab Payload Accommodation Handbook.

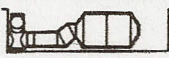
Calculating power available to a payload is more complex than estimating mass or volume because it depends on several other factors. Power for experiment use depends on the power consumption of the

Table 2-5.—Electrical power and energy resources for payloads

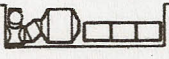
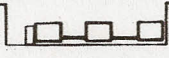
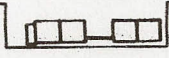
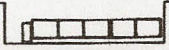
Configuration	Maximum continuous power available to payload, kW			Additional peak power available to payload, kW		Total energy available to payload, kWh (MJ)	
	Max.	Min.	Essential power portion	15 min/3h	3h/3h (equalized)	Max.	Min.
	3.4	2.1	0.06	4.3	0.36	289 (1040)	86 (310)
	3.0	1.7	.06	4.3	.36	226 (814)	24 (86)
	3.0	1.7	.06	4.3	.36	226 (814)	24 (86)
	3.0	2.1	.06	4.3	.36	226 (814)	86 (310)
	3.0	2.1	.06	4.3	.36	226 (814)	86 (310)
	4.8	4.4	^a .28	4.3	.36	507 (1825)	414 (1490)
	4.8	4.4	^a .28	4.3	.36	507 (1825)	414 (1490)
	4.8	4.4	^a .28	4.3	.36	507 (1825)	414 (1490)

^aLimited by 10-ampere fuse.

basic Spacelab subsystems and is also a function of the use of mission-dependent equipment. A maximum amount of power is available to the experiments if no discretionary subsystem or mission-dependent equipment is used, and a minimum amount of power is available if all the discretionary subsystem mission-dependent equipment has been selected.

The command and data management subsystem is largely independent of the Orbiter. It provides data acquisition command, formatting, display, and recording. Communication with ground stations is through the Orbiter's communication system. The communications network and data-handling procedures for all STS payloads are described in part 4.

Table 2-6.—Heat rejection capabilities and module atmosphere aspects

Parameter	Configuration	
	Module	Pallet
Atmosphere		(Igl00)
Nominal total pressure, bar (N/m ²)	1.013 ± 0.13 (101 300 ± 13 000)	^a 1.096 (109 600)
Nominal partial oxygen pressure, bar (N/m ²)	0.220 ± 0.017 (22 000 ± 1700)	^b 0.035 (3500)
Nominal partial carbon dioxide pressure, bar (N/m ²)	0.0067 (670)	
Cabin air temperature, °F (K)	64 to 81 (291 to 300)	^c 95 (308)
Minimum humidity (dewpoint), °F (K)	43 (279)	
Maximum relative humidity, percent	70	
Maximum allowable internal wall temperature, °F (K)	113 (318)	
Air velocity in habitable area, ft/sec (m/sec)	0.33 to 0.66 (0.1 to 0.2)	
Total heat transport capability, ^d kW	8.5	8.5
Prelaunch/postlanding power, ^d kW		
With ground support equipment connected		
Orbiter powered down	1.5	1.5
Orbiter powered up	1.5	1.5
Ascent/descent	1.5	1.5
Peak heat rejection capability ^d		
For payload power peaks during operational phase, kW	12.4	12.4
Minimum interval between peaks, min	165	165

^aMaximum gaseous nitrogen differential pressure.

^bMinimum gaseous nitrogen differential pressure.

^cMaximum internal temperature.

^dAvailable to payload and Spacelab subsystems.

Table 2-7.—Command and data-handling resources

Payload data acquisition	
Housekeeping and low-rate scientific data (to computer via RAU's)	
Number of RAU's in basic system	8
Maximum number of RAU's (extension capability)	22
Number of flexible inputs (analog or digital) per RAU	128
Analog: resolution of analog/digital conversion, bits	8
Discrete: number of inputs addressable as group	16
Number of serial pulse-code-modulation inputs per RAU	4
Clock rate, Mbps	1
Maximum number of words transferred per sample	32
Word lengths, bits	17
Maximum basic sampling rate, Hz	100
Data rate of transfer RAU/computer (including overhead), Mbps	1
Wide-band scientific data	
Number of experiment channels of the high-rate multiplexer (HRM)	16
Minimum data rate of HRM input channels, kbps	64
Maximum data rate of HRM input channels, Mbps	16
Number of closed-circuit television video input channels or analog	14
Data transmission to ground	
Nominal data rate for housekeeping and low-rate scientific data from subsystem and experiment computer, kbps	64
Maximum data rate for wide-band scientific data (via TDRSS ^a), Mbps, or analog/video +2 Mbps	50
Maximum data rate of high-rate digital recorder (HRDR) bridging TDRSS noncoverage periods, Mbps	32
Storage capability of high-data-rate recorder (HDRR), bits	3.6 × 10 ¹⁰
Payload command capability	
Telecommand rate from ground via Orbiter, kbps	2
Number of on/off command outputs per RAU	64
Number of serial pulse-code-modulation command channels per RAU	4
Clock rate, Mbps	1
Maximum number of words per command	32
Word length (including parity bit), bits	17
Payload data processing and displays	
Data processing:	
Word length, bits	16
Speed (Gibson mix), operations/sec	350 000
Floating point arithmetic, bits	32 (24 + 8)
Mass memory, Mbits	131
Display:	
Alphanumerical display screen (tricolor) diagonal, in. (cm)	12 (30.5)

^aTracking and Data Relay Satellite System.

Mission scenarios

In order to orient the user in the uses of Spacelab, several Spacelab conceptual mission studies are described in the following pages. The mission studies can be used for planning purposes, but none has been specifically approved as a NASA mission. For missions supporting specific disciplines in basic science or technology, NASA will provide specialized research and development facilities and equipment.

These Spacelab missions will concentrate on intense short-term investigations and will therefore complement those long-term observations programs that use free-flying satellites. Payload operations studies have been directed at providing the greatest scientific return from each mission while most effectively using the resources of the Spacelab, the standardized experiment equipment, the individual experimenter's equipment, and the expertise of the crew. The payload specialist, trained by the user and working with ground-based scientists and technicians, is an integral part of the plan.

The modular design of the Spacelab and of the specialized experiment equipment (fig. 2-24) permits their repeated use in long-range program planning. They provide broad flexibility to accommodate the diverse needs of both large and small users. The available equipment, as well as the number of planned missions, can be varied in response to user

interests and requirements. The equipment can be used as part of mixed payloads as well.

The three levels of user involvement in these specialized missions are defined as follows.

1. The user provides the complete experiment unit, both the facilities and the detectors or samples.
2. The user provides only the experiment, which will be accommodated by standardized NASA-provided equipment.
3. The user provides no actual experiment or hardware but receives data generated on a mission (such as Earth observations images or tapes).

Planned missions will involve space processing, advanced technology, Earth viewing, life sciences, astronomy, astrophysics, solar physics, and terrestrial physics.

For all missions, NASA will manage the Spacelab operational activities. These include experiment integration; payload specialist training; checkout; flight operations; refurbishment; and data acquisition, preliminary processing, and distribution.

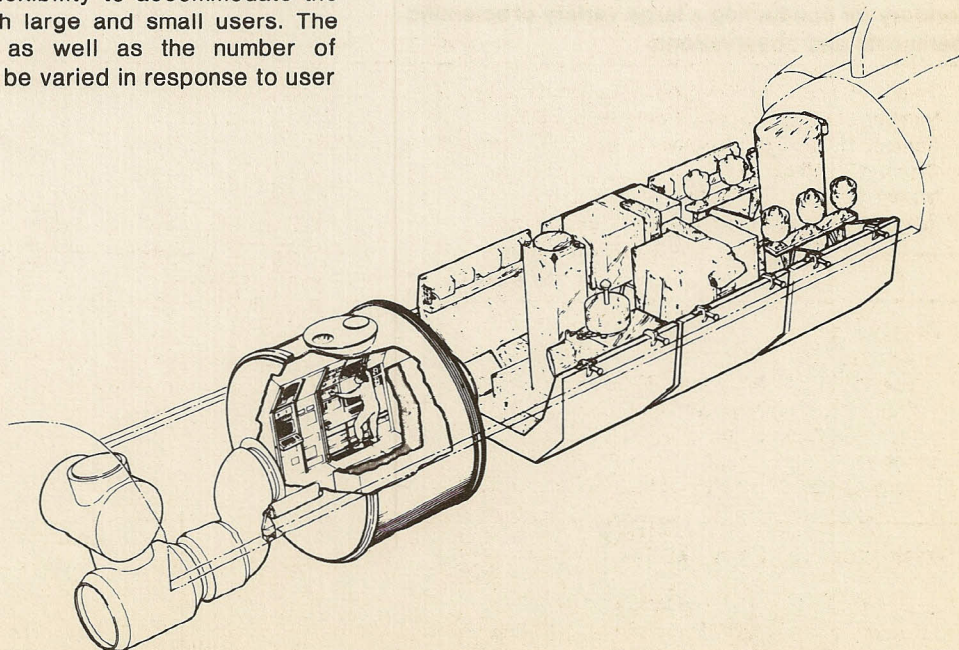

Figure 2-24.— Potential Shuttle/Spacelab configuration.

Astrophysics payloads

The astrophysics payloads (APP) project involves a set of instruments that will be used to investigate a wide range of long-term scientific problems in astrophysics, including the origin and future of matter, the nature of the universe, the life cycle of the Sun and stars, and the evolution of solar systems.

Solar physics payloads

The Spacelab solar physics payloads (SPP) missions involve instruments designed to obtain data that will be used to understand the fundamental physical processes of energy production in the solar interior, the transport of this energy through the solar atmosphere, and its ultimate dissipation through radiation, acceleration of plasma, and the solar wind.

The emphasis of the early SPP missions will be on solar/terrestrial interactions. The two specific areas identified for initial investigation are the solar wind/Sun interface and high-energy acceleration processes.

Manned physics laboratory

A dedicated Spacelab will be used for the atmospheric magnetospheric plasma system (AMPS) project, which consists of a manned physics laboratory for conducting a large variety of scientific experiments and observations.

The objective of the AMPS project is to assist in developing a comprehensive understanding of the region surrounding the Earth. This involves studying the Earth's electric and magnetic field system, energetic particle and electromagnetic wave interactions, the physical processes associated with the motion of bodies in rarefied plasmas, and the chemistry and dynamics of the upper atmosphere.

Advanced technology laboratory

The advanced technology laboratory (ATL) is a Spacelab mission with emphasis on technology objectives. It represents the space research laboratory of the 1980's, providing the researcher with vacuum conditions, null gravity, a benign environment, the recovery of experiment equipment, and quick-response space research.

The ATL provides a new dimension in the development of spaceborne systems: the flight test. It is an organized, systematic approach for continuing and extending research and technology efforts in space.

Life sciences experiments

The project for in-orbit life sciences payloads is being developed by the NASA Office of Space Science to use the Spacelab to conduct research in the null gravity and altered environments (radiation, acceleration, light, magnetic fields, etc.) of space. The Shuttle/Spacelab presents a unique capability to perform numerous experiments in all fields of life sciences; i.e., biomedicine, vertebrates, man/system integration, invertebrates, environment control, plants, cells, tissues, bacteria, and viruses (fig. 2-25). The broad objectives are to use the space environment to further knowledge in medicine and biology for application to terrestrial needs and to ensure human well-being and performance in space.

The project is structured for the widest participation from the public and private sectors and is characterized by low-cost approaches, many flight opportunities, short experiment turnaround times, provisions for qualified investigators to fly with their experiments, and maximum use of existing or modified off-the-shelf hardware.

Additional information about the Spacelab Program in general is available in the United States from the National Aeronautics and Space Administration, George C. Marshall Space Flight Center, Mail Code NA01, Marshall Space Flight Center, Alabama 35812; telephone (205) 453-4610; FTS 872-4610. In Europe, Spacelab information is available from the European Space Agency, 8-10 Rue Mario Nikis, 75738 Paris Cedex 15, France.

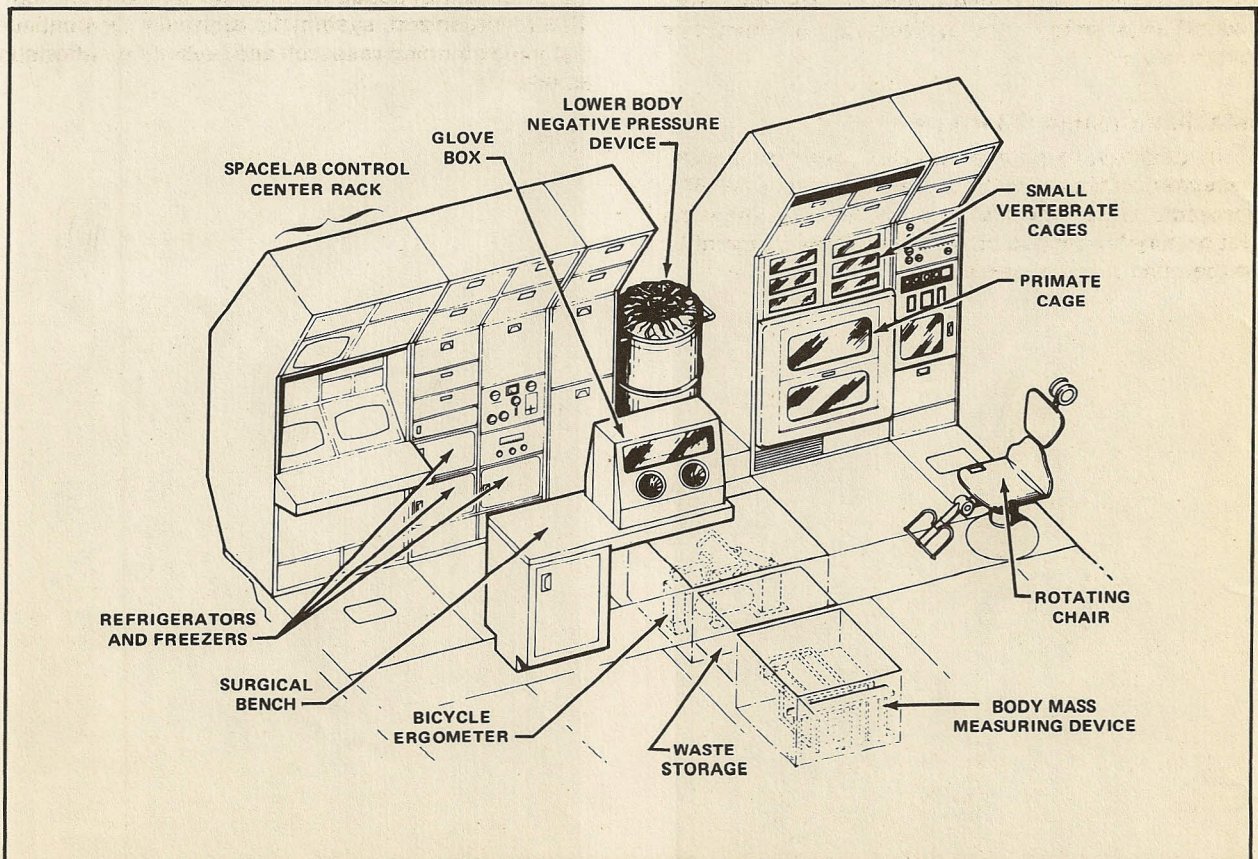

Figure 2-25.— Typical layout for a Spacelab dedicated to life sciences, with possible locations of center aisle and starboard racks.

UPPER STAGES

The expendable upper stage is a reliable, simple, low-cost vehicle for spacecraft missions with altitudes, inclinations, and trajectories beyond the basic Shuttle capability. The upper stage systems consist of one or more solid-propellant propulsive stages, airborne support equipment, ground support equipment, software, and unique facilities.

Two upper stage systems are currently planned (fig. 2-26). A solid-propellant spin-stabilized stage called the payload assist module (PAM) is designed for Atlas-Centaur and Delta class missions. The solid-propellant three-axis-stabilized inertial upper stage (IUS) is intended for boosting single or multiple spacecraft to higher orbits and escape trajectories.

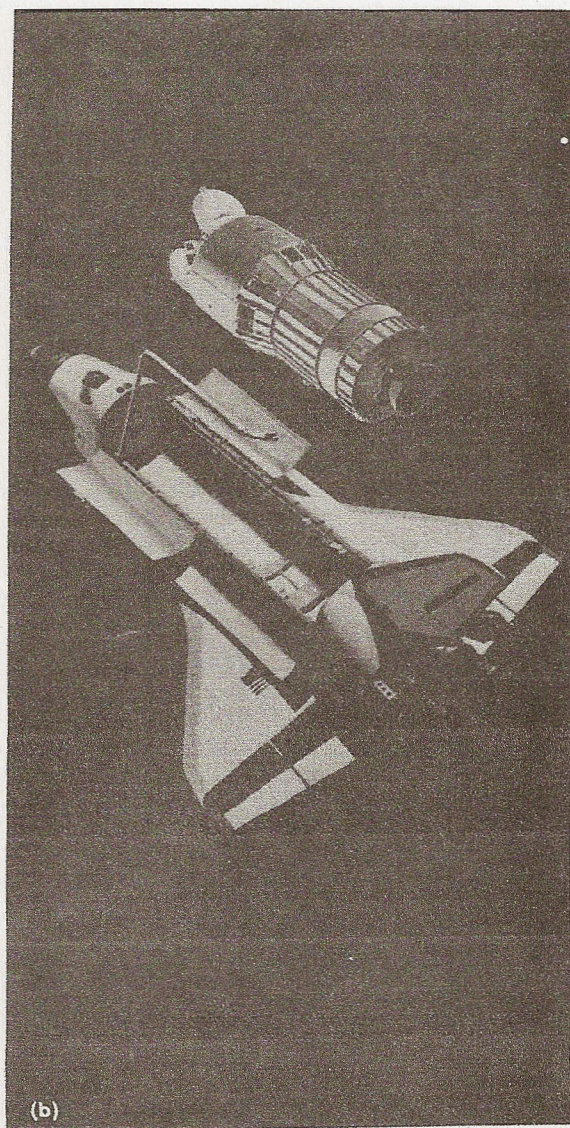
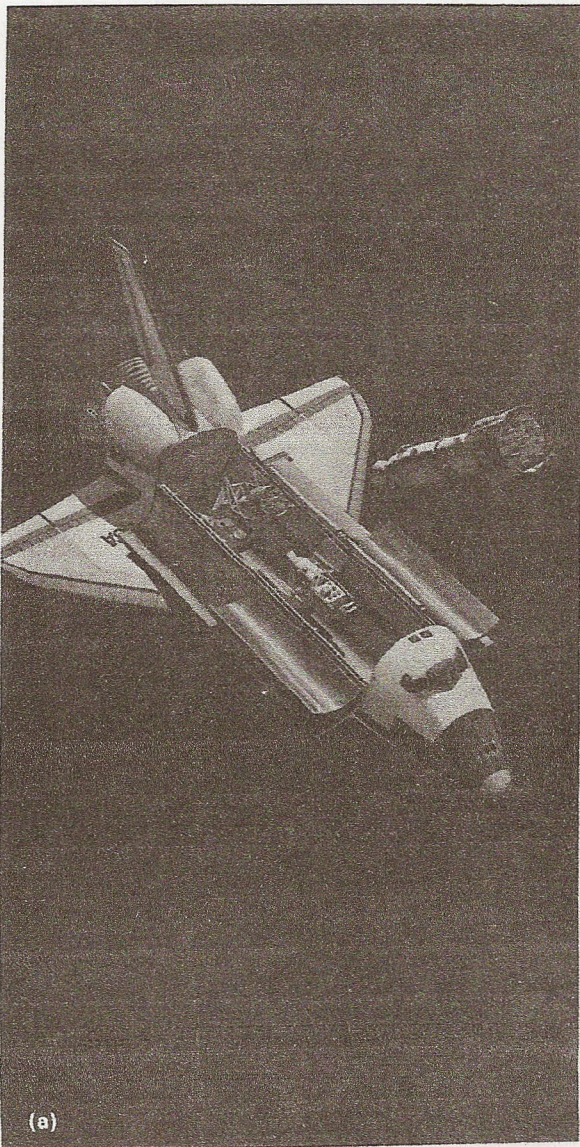

Figure 2-26.— Upper stage systems. (a) Payload assist module. (b) Inertial upper stage.

Payload assist module

The PAM, being planned by NASA, relies on an initially imparted delta-velocity and spin momentum for trajectory and stability control to boost a single spacecraft to a predetermined destination or transfer orbit. The PAM/STS capability is comparable to that of current expendable launch vehicles.

The Shuttle Orbiter performs the initial pointing, spin up, and release of the PAM, similar to that performed by the first two stages of the Delta three-stage launch vehicle. The PAM performs the function of the Delta third stage for transfer orbit injection.

This approach will simplify the user's transition from expendable vehicles to the STS, with the additional advantage of multiple spacecraft launches or shared launches with other payloads. The result will be a significantly lower cost to the user for each spacecraft launch.

The PAM is designed to accommodate two primary classes of spacecraft: the Delta class, which accommodates up to a maximum of 2400 pounds (1088 kilograms) to be placed into geosynchronous transfer orbit, and the Atlas-Centaur class, which accommodates 4000 to a maximum of 4400 pounds

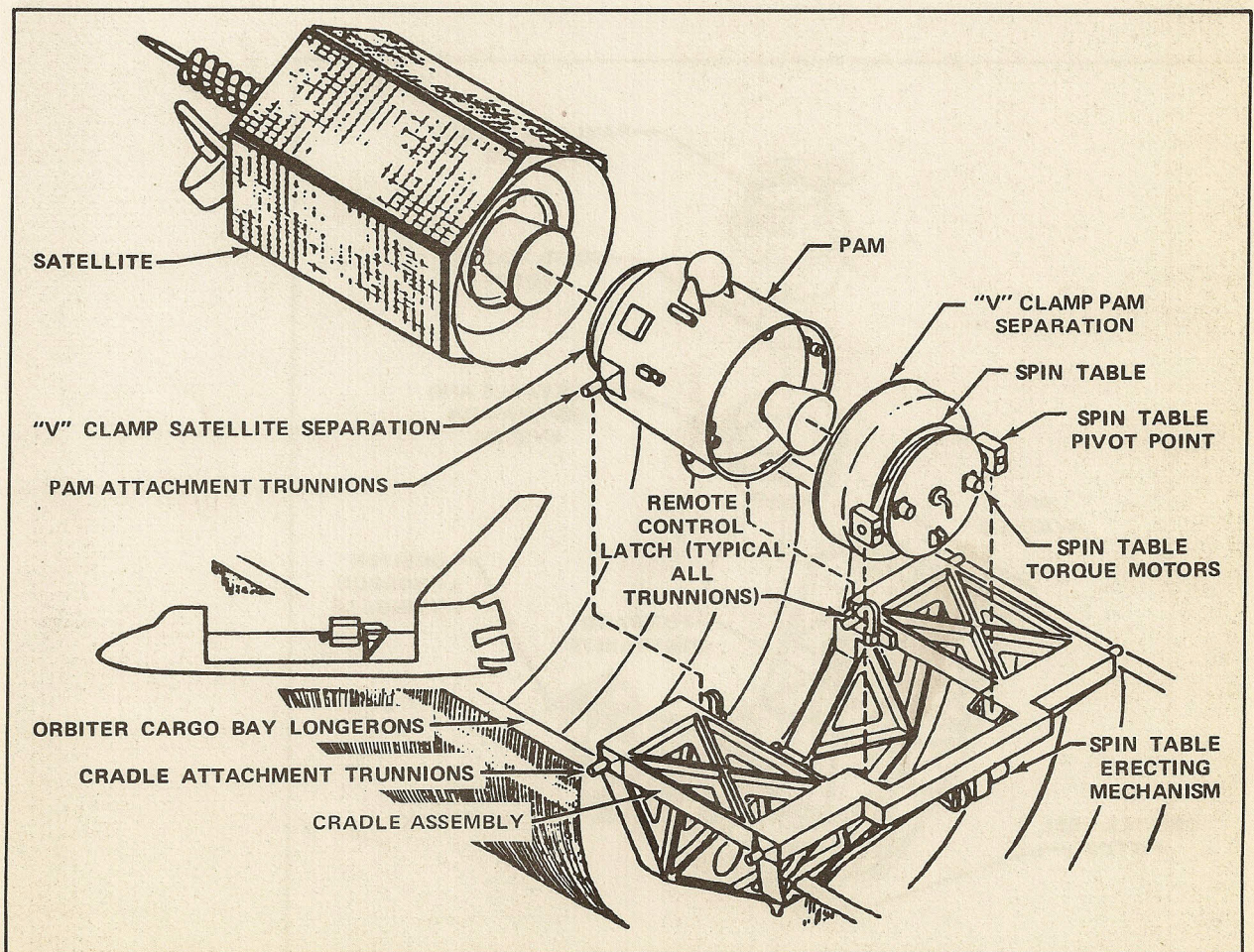

Figure 2-27.— Diagram of PAM-A structure in cargo bay.

(1800 to 2000 kilograms) to be put into geosynchronous transfer orbit. It is expected that four Delta class (PAM-D) or two Atlas-Centaur class (PAM-A) stages with spacecraft can be carried on a single Shuttle flight. One or two PAM's and spacecraft may also share a flight with other payloads.

For a nominal geosynchronous mission, the Shuttle Orbiter carries the payload into a 160-nautical-mile (296-kilometer) circular orbit inclined at 28.5°. After checkout, the PAM and spacecraft are spun up and deployed (fig. 2-27). The spinup procedures are initiated and controlled from the Orbiter aft flight

deck. Spin capabilities of up to 100 rpm for the PAM-D and 65 rpm for the PAM-A are available from the airborne support equipment (ASE) spinup mechanism (fig. 2-28). After the PAM and spacecraft are released, the Orbiter maneuvers to a position to allow initiation of a separation maneuver. The PAM and Orbiter coast in the parking orbit for approximately 45 minutes until the appropriate crossing of the Equator. At this time, the PAM motor fires and injects the PAM and spacecraft into a 160- by 19 323-nautical-mile (296- by 35 786-kilometer) geosynchronous transfer orbit.

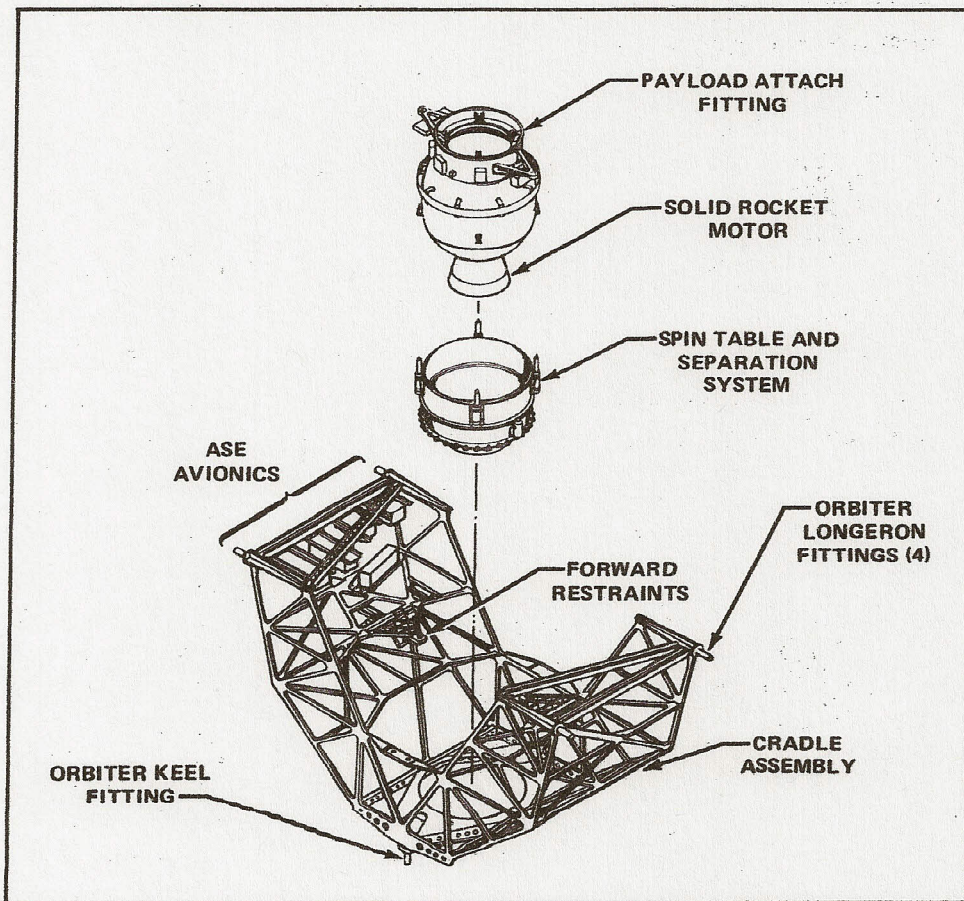

Figure 2-28.— STS PAM-D system hardware.

Inertial upper stage

The IUS, under development by the Department of Defense (DOD), relies on a three-axis-stabilized propulsive and avionics system for trajectory and stability control to place larger class spacecraft or multiple spacecraft in Earth orbit, or to place planetary spacecraft on escape trajectories. The IUS has the potential for simple and standard operational and functional interfaces with the spacecraft, Orbiter, supporting facilities, and ground equipment for a wide range of missions. Spacecraft are cantilevered from the interface adapter and all services to and from the spacecraft are through the IUS. Deployment

is accomplished by means of a spring ejection system.

The IUS family consists of a basic two-stage vehicle with twin- and three-stage configurations for the high-energy missions (fig. 2-29). The two-stage vehicle can accomplish all the projected DOD and NASA Earth-orbital missions. The twin-stage vehicle consists of two large motors. The three-stage vehicle is formed by adding another large motor as a lower stage to the two-stage vehicle. The twin- and three-stage vehicles are required for the Earth-escape missions. See the document Inertial Upper Stage User Guide.

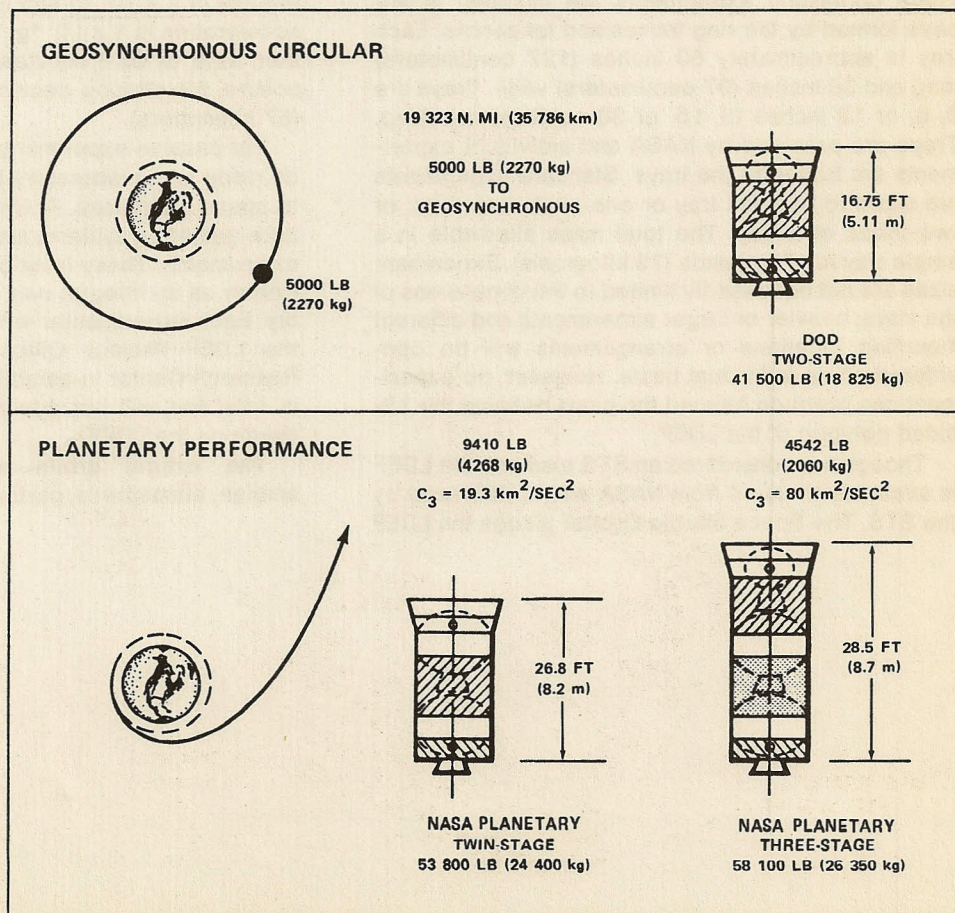

Figure 2-29.— Preliminary performance options of the IUS configurations.

LONG DURATION EXPOSURE FACILITY

The Long Duration Exposure Facility (LDEF), being developed by the NASA Office of Aeronautics and Space Technology, is a reusable, unmanned, gravity-gradient-stabilized, free-flying structure. It can accommodate many technology, science, and applications experiments, both passive and active, that require exposure to space. The LDEF provides an easy and economical means for conducting these experiments.

The LDEF is a 30-foot (9-meter) long structural framework as shown in figure 2-30, with room for 72 experiment trays on the periphery and 14 trays on the ends. The LDEF cross section is a 12-sided regular polygon of bolted aluminum I-beam construction with a diameter of 14 feet (4.3 meters). The primary framework consists of 7 ring frames and 12 longerons fabricated from aluminum extrusions. Trays containing experiments are mounted in the bays formed by the ring frames and longerons. Each tray is approximately 50 inches (127 centimeters) long and 38 inches (97 centimeters) wide. Trays are 3, 6, or 12 inches (8, 15, or 30 centimeters) deep. Trays are provided by NASA and individual experiments are bolted to the trays. Standard experiments are sized to fill a full tray or one-sixth, one-third, or two-thirds of a tray. The total mass allowable in a single tray is 175 pounds (79 kilograms). Experiment sizes are not necessarily limited to the dimensions of the trays; heavier or larger experiments and different mounting locations or arrangements will be considered on an individual basis. However, no experiment can protrude beyond the plans defining the 12-sided polygon of the LDEF.

Though not considered an STS element, the LDEF is available to users from NASA and is delivered by the STS. The Space Shuttle Orbiter places the LDEF

in Earth orbit, where it remains for 6 months or more until another Shuttle flight retrieves it and returns it to Earth. In orbit, the Orbiter remote manipulator system removes the LDEF from the cargo bay. The longitudinal axis of the LDEF is aligned with the local Earth vertical (fig. 2-31), other required orientations are established, and the angular velocities are brought within specified limits. The LDEF is then released into a circular orbit of approximately 300 nautical miles (556 kilometers) with an inclination to the equatorial plane between 28.5° and 57°. Gravity-gradient stabilization is used in combination with a viscous magnetic damper to null transients. Initially, the LDEF undergoes large periodic motions. Within 8 days, the steady-state point is within 2° of local Earth vertical and oscillations about the longitudinal axis are within 5°. The maximum acceleration level at release is $1 \times 10^{-3}g$ and the maximum steady-state acceleration is $1 \times 10^{-6}g$. The orbital period ranges from 92.8 to 95.6 minutes. During the planned exposure, the altitude decays about 20 nautical miles (37 kilometers).

For passive experiments, data measurements will be made in the laboratory before and after exposure to space conditions. Power, data storage, and other data-gathering systems may be necessary for active experiments. These must be provided by the experimenter as an integral part of the experiment assembly. Each experimenter will work cooperatively with the LDEF Project Office at the NASA Langley Research Center in establishing that the experiment is safe and will not adversely affect other experiments on the LDEF.

The "natural" orbital environment (acceleration, ambient atmosphere, particle flux, magnetic field, and

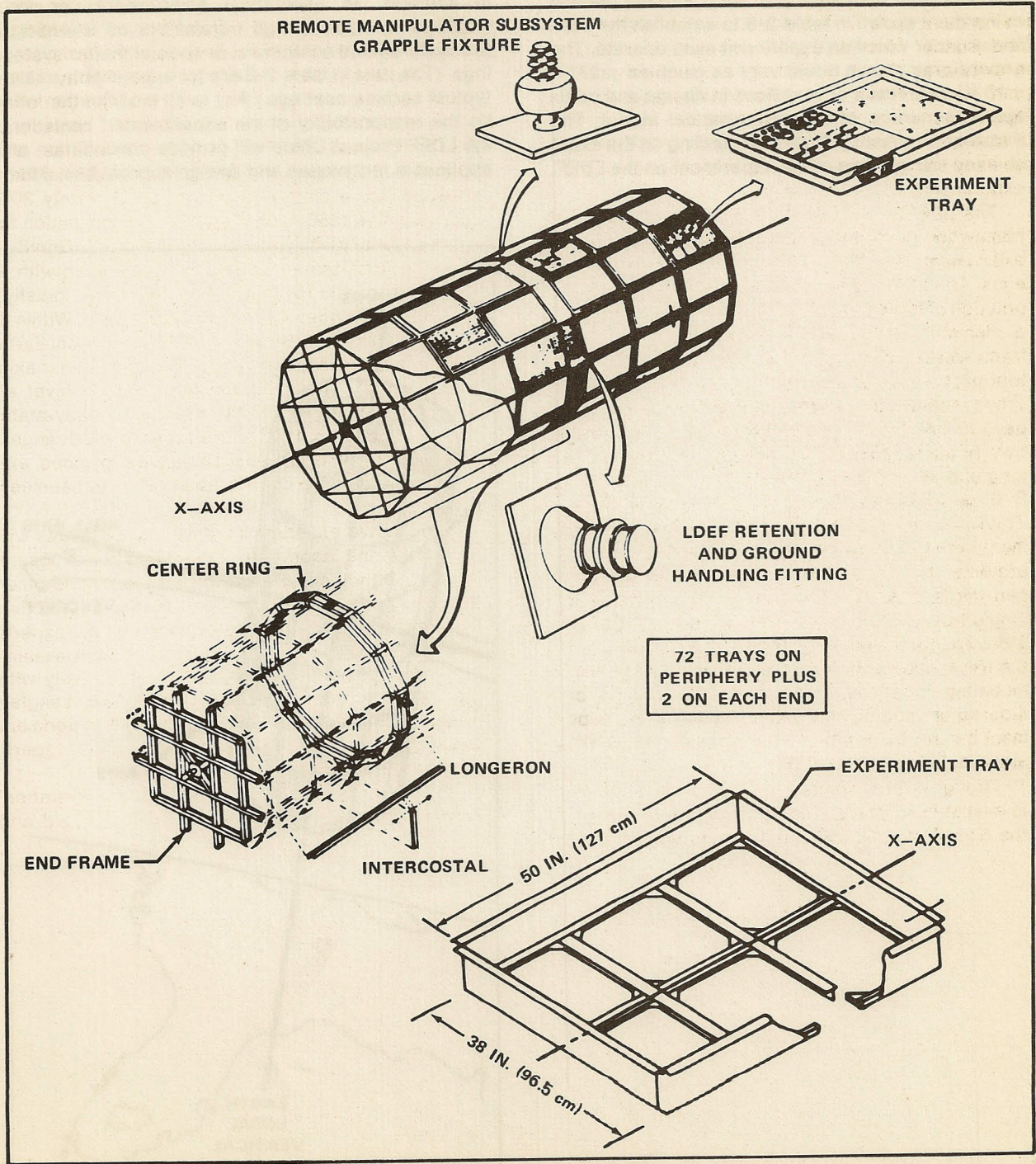

Figure 2-30.— Structural characteristics of LDEF and experiment trays.

solar radiation) combines with the predicted thermal environment shown in table 2-8 to establish the conditions under which an experiment must operate. The temperatures shown could vary as much as $\pm 27^{\circ}\text{F}$ ($\pm 15\text{ K}$) as a result of variations in design and coatings or accuracy of the mathematical model. The overall environment will vary, depending on the exact orbit and the location of the experiment on the LDEF.

In addition, an experiment environment can be modified by such design parameters as shielding, pressure-sealed containers, or special thermal coatings. (The data in table 2-8 are for experiments using typical surface coatings.) Any such modification will be the responsibility of the experimenter; however, the LDEF Project Office will provide consultation on applicable techniques and design approaches. After

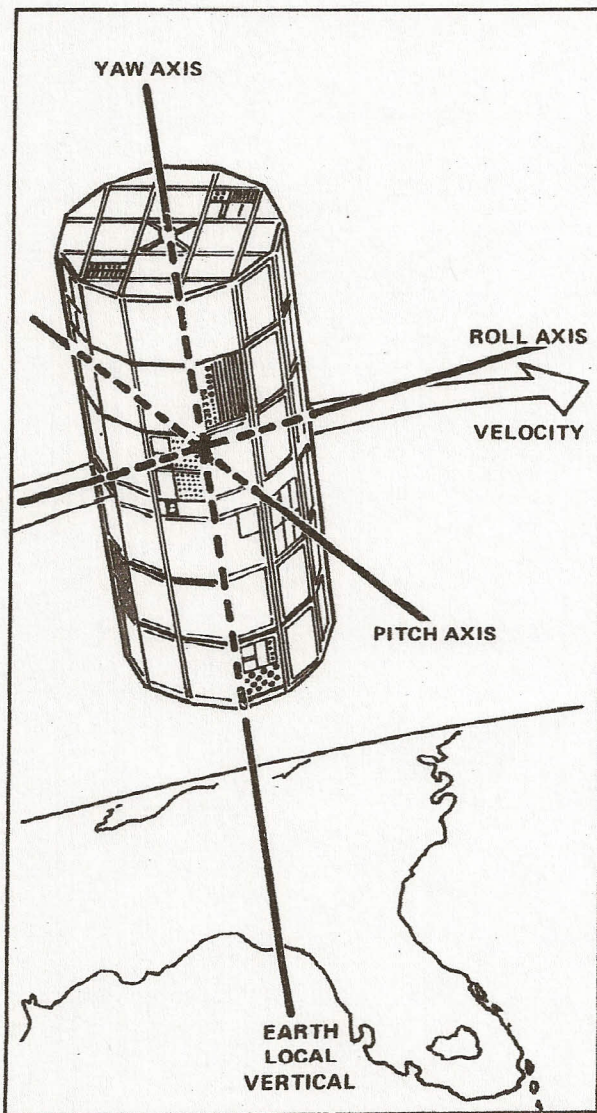

Figure 2-31.— Orientation of LDEF in free flight.

an experiment is selected for the LDEF, the LDEF Project Office will define the specific conditions available and work closely with each experimenter in choosing the best possible location for the experiment.

The LDEF Project Office has the overall responsibility for experiment integration (fig. 2-32). Experimenters will assemble their own flight experiments and, when using full trays, may also mount them in the trays. Experiments will be sent to Langley Research Center, where partial-tray experiments will be mounted and all trays will undergo flight acceptance testing. The LDEF Project Office also will provide for the correct placement of trays on the LDEF to obtain the desired exposure, field of view, etc., and will ensure the mutual compatibility of all experiments. The trays will be sent to the KSC launch site, where they will be bolted onto the LDEF.

An experimenter may participate in launch site operations and verify flight readiness of the experiment, if required. The experimenter will also have an opportunity to view the experiment on its return from orbit, before it is removed from the LDEF at KSC.

Because the LDEF can fly a wide variety of missions, the exposures available for experiments cannot be fully presented in a brief summary. Data given here are intended to serve only as a guide to the prospective experimenter. More detailed data are provided in the Long Duration Exposure Facility (LDEF) Guide for Experiment Accommodations, prepared by the LDEF Project Office. Additional information is available from the LDEF Experiments Manager, Mail Stop 258, National Aeronautics and Space Administration, Langley Research Center, Hampton, Virginia 23665; telephone (804) 827-3704, FTS 928-3704.

Table 2-8.—Predicted LDEF thermal environment ranges
[57° inclination orbit]

Location	Minimum temperature, °F (K)	Maximum temperature, °F (K)	Typical temperature differential per orbit, °F (K)
On LDEF structure			
Internal average	-22 (243)	95 (308)	—
Earth end (aluminum surface)	-13 (248)	104 (313)	9 (5)
Space end	-13 (248)	113 (318)	45 (25)
Typical experiment			
Internal surfaces, $\alpha = 0.3, \epsilon = 0.3^a$	-31 (238)	122 (323)	5 (3)
External surfaces	-40 (233)	167 (348)	
Internal surfaces, $\alpha = 0.25, \epsilon = 0.17$	-58 (223)	149 (338)	18 (10)
Thin external surfaces	-175 (158)	302 (423)	364 (202)
Internal surfaces, $\alpha = 0.3, \epsilon = 0.8$	-53 (226)	86 (303)	11 (6)
External surfaces	-103 (198)	86 (303)	—

^a α = absorptivity, ϵ = emissivity.

INTERFACE FLOW

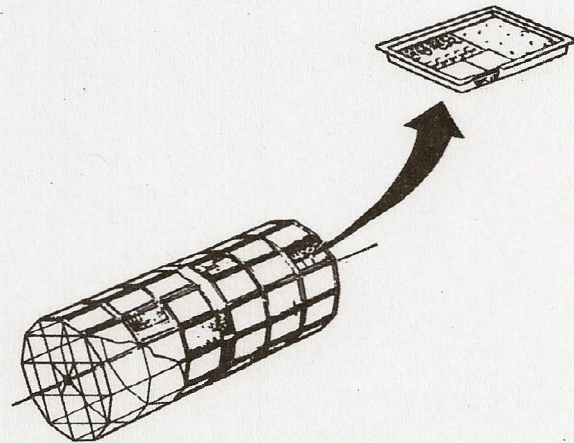
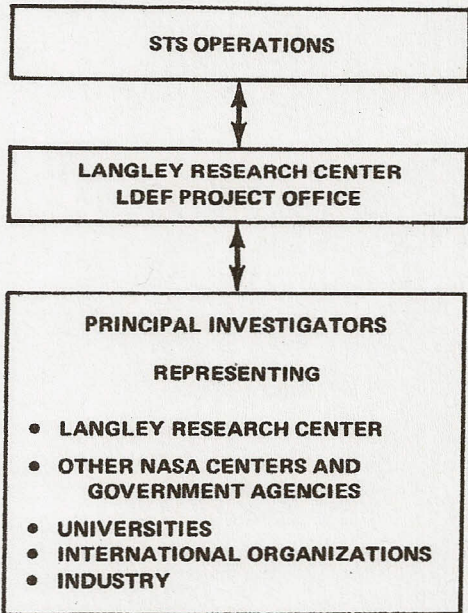

CALENDAR YEAR

1982	1983	1984
------	------	------

SCHEDULED ACTIVITY TBD

Responsibility	Phase						
	Initial program planning and approval	Mission and experiment planning	Operations integrated planning, ^a T-2 years to T-16 weeks	Final flight planning, T-16 weeks to T=0	STS flight operations	LDEF flight operations	Postflight
Langley Research Center	Primary	Primary	Primary	Support	Support to POCC	Primary	Primary
STS operations	Provide User Handbook	Provide STS user references	Provide supporting documentation	Primary	Primary	None	None

^aT = time from launch.

Figure 2-32.— An example of a principal investigator's involvement in ongoing LDEF operations. The primary interface is shown, along with a flight schedule and the NASA centers' responsibilities.

MULTIMISSION MODULAR SPACECRAFT

The Multimission Modular Spacecraft (MMS), developed as a standard modular spacecraft, can be used in low Earth and geosynchronous orbits for a wide range of remote-sensing missions (fig. 2-33). Although not classified as an STS element, it is fully compatible with the launch environments and other requirements of the Space Shuttle as well as with a variety of expendable launch vehicles (particularly the Delta 3910 and 3920 series).

The reusable MMS offers several significant advantages. Within its standard range of capabilities, it can be adapted to many varied payload requirements, eliminating the need for costly and time-consuming design and development activities.

The Multimission Modular Spacecraft with its payload can either be returned from space or serviced on orbit by the Space Shuttle. This represents a major cost-saving potential. In instances where on-orbit repair or refurbishment is not desired, the MMS can be retrieved by the Space Shuttle, returned to Earth for refurbishment or upgrading, and relaunched.

The first MMS with a solar maximum mission (SMM) payload was successfully launched from the Eastern Test Range (ETR) on February 14, 1980. SMM retrieval and servicing demonstration is tentatively planned to occur some 3 years from launch.

For STS launches, the flight support system (FSS) that carries the MMS in the Orbiter cargo bay also

provides deployment, retrieval, and on-orbit servicing capability. In addition, the FSS is versatile enough to support other types of spacecraft.

The program management responsibility for development of the MMS and the FSS is within the NASA Office of Space Sciences. More detailed information on MMS capabilities and missions, as well as on the FSS, is contained in the Multimission Modular Spacecraft and Flight Support System User Guides prepared by the Goddard Space Flight Center, which is responsible for technical management of the MMS project. Copies of the guides and of other information are available from the MMS Project Office, Mail Code 408, National Aeronautics and Space Administration, Goddard Space Flight Center, Greenbelt, Maryland 20771; telephone (301) 344-5913, FTS 344-5913.

MMS systems and capabilities

The basic MMS consists of two major structural assemblies and three major subsystem modules. The module support structure interfaces with the transition adapter and is the central core structure of the MMS. It carries all structural loads imposed by, and all structural and functional interfaces with, the modules. In addition, when the MMS is launched on expendable vehicles, the module support structure carries all launch loads.

Either a circular or a triangular transition adapter, providing a standard payload interface to the MMS, provides the interface to the Space Shuttle Orbiter (through appropriate supporting hardware). The module support structure grapple provides the capture point interface to the Shuttle remote manipulator system for retrieval and on-orbit servicing of the spacecraft and instrument payload.

The three major subsystem modules, each having a standard range of performance capabilities, provide communications and data handling, power, and attitude control services (table 2-9). Optional propulsion modules are available and a variety of mission-specific subsystem elements can be added to tailor the capabilities of the MMS to the user's requirements. Examples include tape recorders, general processing system equipment, additional memory in the command and data-handling module, or additional batteries in the power module. Additional requirements such as low- and high-gain antenna systems and solar arrays, also considered mission-specific, must be supplied by the user.

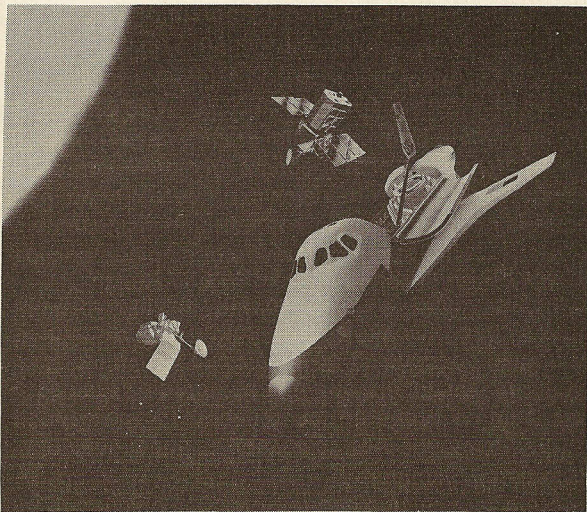

Figure 2-33.— Typical Multimission Modular Spacecraft mission configurations.

Table 2-9.—MMS capabilities

General capabilities	
Payload weight	For Shuttle launches, in excess of 10 000 lb (4536 kg) limited by payload configuration
Orbital capability	Low-Earth, 270 to 864 n. mi. (500 to 1600 km), at any inclination, and geosynchronous
Life expectancy/redundancy	Minimum life expectancy, 2 yr. The MMS is designed to have no single-point failure that will prevent resupply or retrieval by Shuttle.
Subsystem performance capabilities	
Communications and data handling subsystem	
Transponder	S-band, STDN ^a /TDRSS, transponder output power at antenna port 0.8, 2.0, 4.0 W, prelaunch selectable
Command rates	2 kbps, baseline; 125 to 1 kbps, selectable
Telemetry rates	1, 2, 4, 8, 16, 32, or 64 kbps
Telemetry formats	2 selectable prior to launch, plus in-orbit programmable capability; all formats contain 692 data words maximum
Onboard computer	18 bits per word, 32 000 words of memory, baseline; expandable to 64 000 words; 4.4- μ s add time
Payload accommodation	
Maximum remote interface units (RIU) and RIU expanders for experiments	27 units plus 3 expanders per RIU
Command capability per RIU	Eight 16-bit serial magnitude, 62 discrete relay drivers
Telemetry capability per RIU or RIU expander	64 inputs; all usable for analog/discrete bilevel; 16 usable for serial digital, 8 bits each
Attitude control subsystem	
Type	3-axis, zero momentum
Attitude reference (without payload sensor)	Stellar (inertial)
Pointing accuracy (one sigma)	
Without payload sensor	<0.01°
With payload sensor (ideal)	<0.00001° (direct analog signal processing) <0.0001° (signal processing via computer)
Pointing stability (one sigma)	
Average rate	<0.000001 deg/s
Jitter	
Without payload sensor	<0.0006° (20 min)
With payload sensor (ideal)	<0.000001° (direct analog signal processing) <0.00001° (signal processing via computer)
Slew rate	Dependent on spacecraft inertia

^aSpace Flight Tracking and Data Network.

Table 2-9.—Concluded

Subsystem performance capabilities - Concluded	
Power subsystem	
Regulation of load bus	+ 28 ± 7 V dc
Bus noise and ripple	< 1.5 V peak-to-peak (1 to 20 MHz)
Load bus source impedance	< 0.1 ohm (dc to 1 kHz)
	< 0.15 ohm (1 kHz to 20 kHz)
	< 0.30 ohm (20 kHz to 100 kHz)
Typical load switching transients	< ±5 V to steady state
Fault mode transients	Down to 0 V or up to 40 V for 500 ms
Batteries	Two 20-Ah batteries, baseline; up to three 50-Ah batteries, maximum
Power capabilities	1200 W average; 3000 W peak (allowable for 10 min, once per orbit, day or night)
	850 W available to user without propulsion module
	800 W available to user with propulsion module
Module temperature range	Electronics: 0 to 40° C (273 to 313 K)
	Batteries: 0 to 25° C (273 to 298 K)
Propulsion subsystem	
Propellant	Hydrazine (MIL-P-26536C, Amendment 1)
Propellant load	
PM-I	167 lb (75.8 kg)
PM-IA	510 lb (231.4 kg)
Pressurant	Gaseous nitrogen
Thrusters	12 at 0.2 lbf (0.9 N); 4 at 5 lbf (22.24 N)
System operating mode	3 to 1 blowdown
Design operating pressure	300 psia (2068 kN/m ²)
Design burst pressure	1200 psia (8274 kN/m ²)
Thermal control	Active and passive
Operating temperature range	10° to 60° C (283 to 333 K)

Flight support system

Both for transport to orbit and for on-orbit servicing and retrieval, the MMS is structurally and functionally supported in the Orbiter cargo bay by the FSS (fig. 2-34). This system consists of two major subsystems: the retention cradles and the payload positioning platform with support avionics. Each of the two major elements can be operated independently or used collectively as a unified system, depending on the specific mission requirements.

During Shuttle launch and landing, the MMS is carried in the retention cradle, which provides mechanical interfaces to the MMS transition adapter (through which launch and landing loads are transmitted). The retention cradle and the RMS may be the only elements necessary for a launch or retrieval mission.

If the mission requires erection out of the cargo bay at a predetermined position relative to the Orbiter, the payload positioning platform is added to the retention cradle. For deployment, the MMS is erected by the platform to a vertical position. It is grappled by the RMS, released from the positioning platform, deployed by the RMS, and released. For retrieval, these operations are reversed. After the Shuttle establishes rendezvous and stationkeeping with a free-flying MMS, the RMS grapples the spacecraft and berths it onto the erected positioning platform. If the MMS is to be returned to Earth, it is lowered into the retention cradle.

For a servicing mission, the payload positioning platform, module servicing tool, and some form of module storage rack are required. Replacement modules are carried in the module storage rack. After

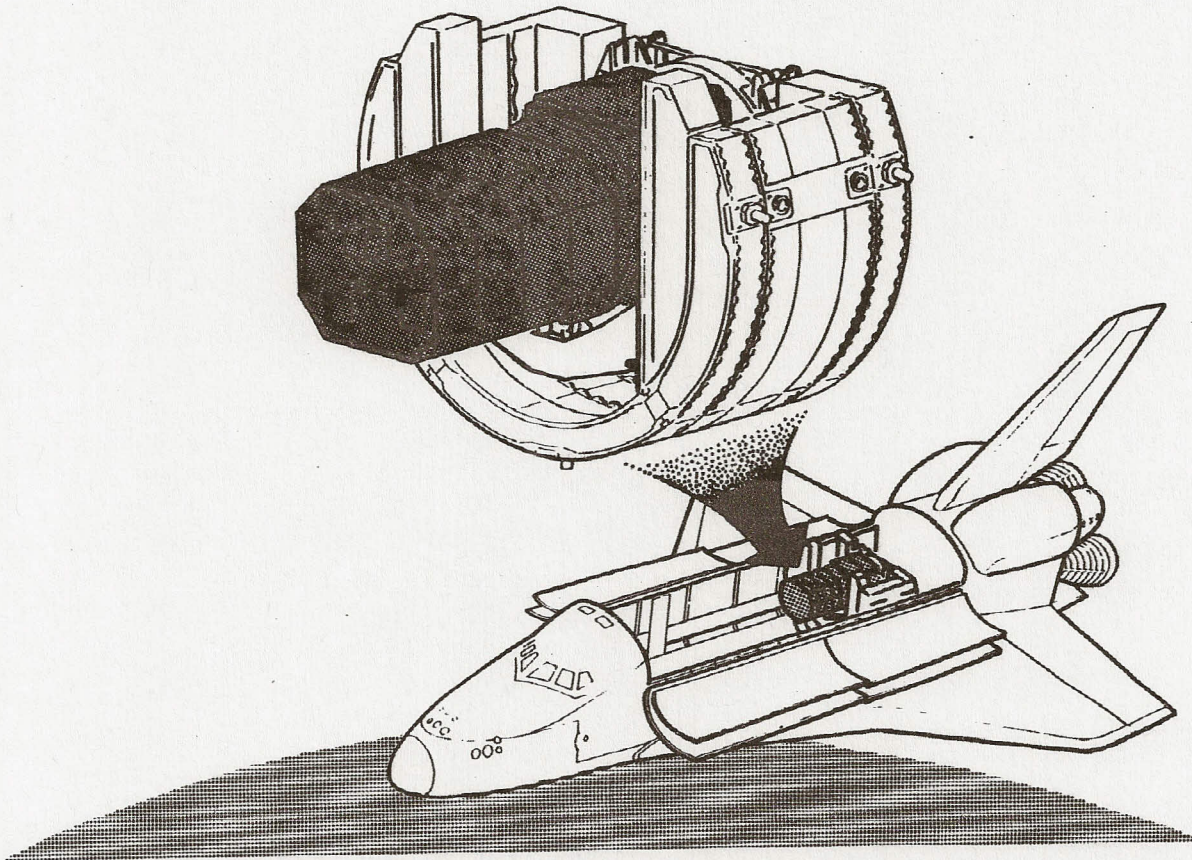

Figure 2-34.— Structural assemblies of the basic flight support system, mounted in the Orbiter cargo bay with solar maximum mission shown as a typical payload.

the MMS is captured and berthed, the primary servicing mode is by manual EVA with an astronaut on a manned remote work station using the module servicing tool. The backup mode is to use the module servicing tool attached to the RMS in a remotely operated automated approach. After the servicing operation is completed and systems are checked out, the MMS is again deployed using the RMS.

The baseline envelope requirement for the retention cradle is the support of one MMS; however, with development of a swing-away latch beam, two MMS's can be accommodated in an over-and-under orientation. Other spacecraft configurations or a complement of mixed spacecraft can be accommodated by the development of interface hardware that satisfies the unique spacecraft requirements on one side and adapts to standardized support system fittings on the other side.

The spacecraft is structurally attached with a set

of three trunnions (mounted on the MMS transition adapter), each locked in place by a remotely operated collet-style latch mechanism. These latches and their supporting structure can be located forward and aft or up and down the side wall structure of the retention cradle. The ability to place these latches almost anywhere in the retention cradle is a key feature in providing payload accommodation versatility.

This pegboard approach is also applied to the payload positioning platform. Depending on the specific mission, the platform can be hinged from three positions in the cradle in order to achieve the desired swing trajectory and erection position. In addition to positional versatility, the payload positioning platform can be modified to accommodate various payload adapters ranging from standoff posts and conventional conical structures to spin tables and spring separation systems.

AN OVERVIEW

User payloads receive final checkout, cargo integration, interface verification, and launch preparation at the launch site. Standard facilities and services are available and are allocated on the basis of user requirements. Special facilities or services required for a specific payload must be provided or funded by the user.

This section is intended to provide the user with a general understanding of the scope of operations at the launch site. Facilities and ground flow at the Kennedy Space Center as well as those unique to the Vandenberg Launch Site (VLS) are described.

The user's responsibilities in support of launch site operations are defined through the standard interfaces and documentation sequences summarized here. The basic document is the KSC Launch Site Accommodations Handbook for STS Payloads (K-STSM-14.1). A launch site support manager (LSSM)

will be assigned early in the planning program and will be the primary interface with the user.

Payloads scheduled for standard carriers such as the Long Duration Exposure Facility will be integrated into the carrier and its ground operations by the organization responsible for that carrier.

A brief explanation of the overall STS ground flow at the outset will help users understand how their own payloads fit into the pattern (fig. 3-1). Operations involving payloads and standard STS elements are described more fully under separate headings.

The Shuttle ground operations at KSC begin when the Orbiter lands. Some payload time-critical items that can be removed through the Orbiter cabin may be removed at this time; for all other payloads, services such as purging and ground power are initiated.

The Orbiter is then towed to the Orbiter Processing Facility (OPF), where payloads are removed.

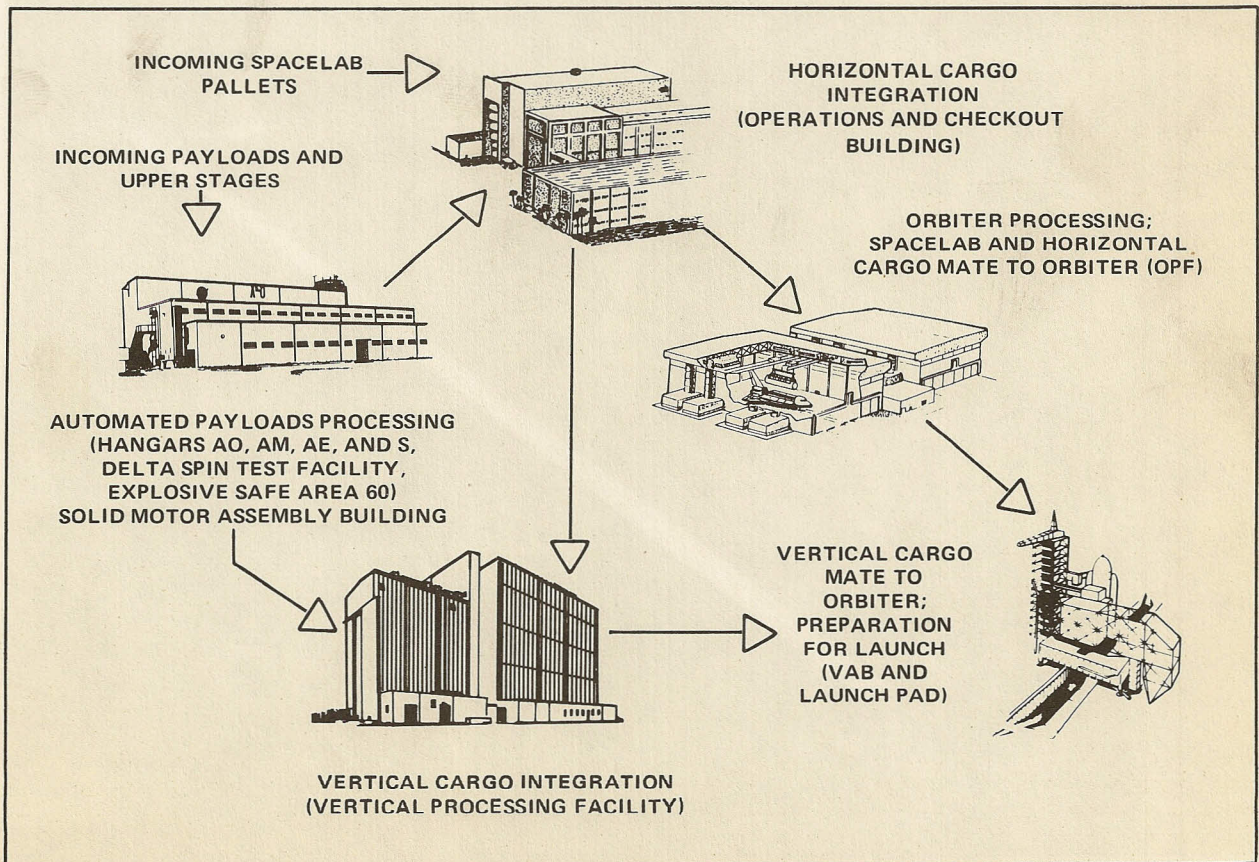

Figure 3-1.— Typical payload ground flow at the launch site.

Maintenance and checkout of the Orbiter for its next flight are done at the OPF, while certain subsystems may be removed and serviced elsewhere.

Meanwhile, new or refurbished payloads are assembled and tested elsewhere at the launch site. Payloads that are installed horizontally are brought to the OPF (in an environmentally controlled payload canister) and put into the Orbiter. The Spacelab, already integrated with its experiments, is installed in the OPF.

The Orbiter is towed to the Vehicle Assembly Building (VAB) (fig. 3-2), where it is hoisted and rotated to a vertical position for mating to the external

tank and solid rocket boosters. The Shuttle vehicle is then transferred to the launch pad on the mobile launcher platform.

Those payloads that require vertical installation in the Orbiter after it has been rotated to a vertical position are brought to the launch pad (in the payload canister) ready for installation and are put into the Orbiter by use of the rotating service structure (RSS). For example, an upper stage/spacecraft cargo is mounted in the Orbiter at this time.

After all necessary procedures and verifications are completed—involving both the Shuttle and the cargo—the countdown for launch begins.

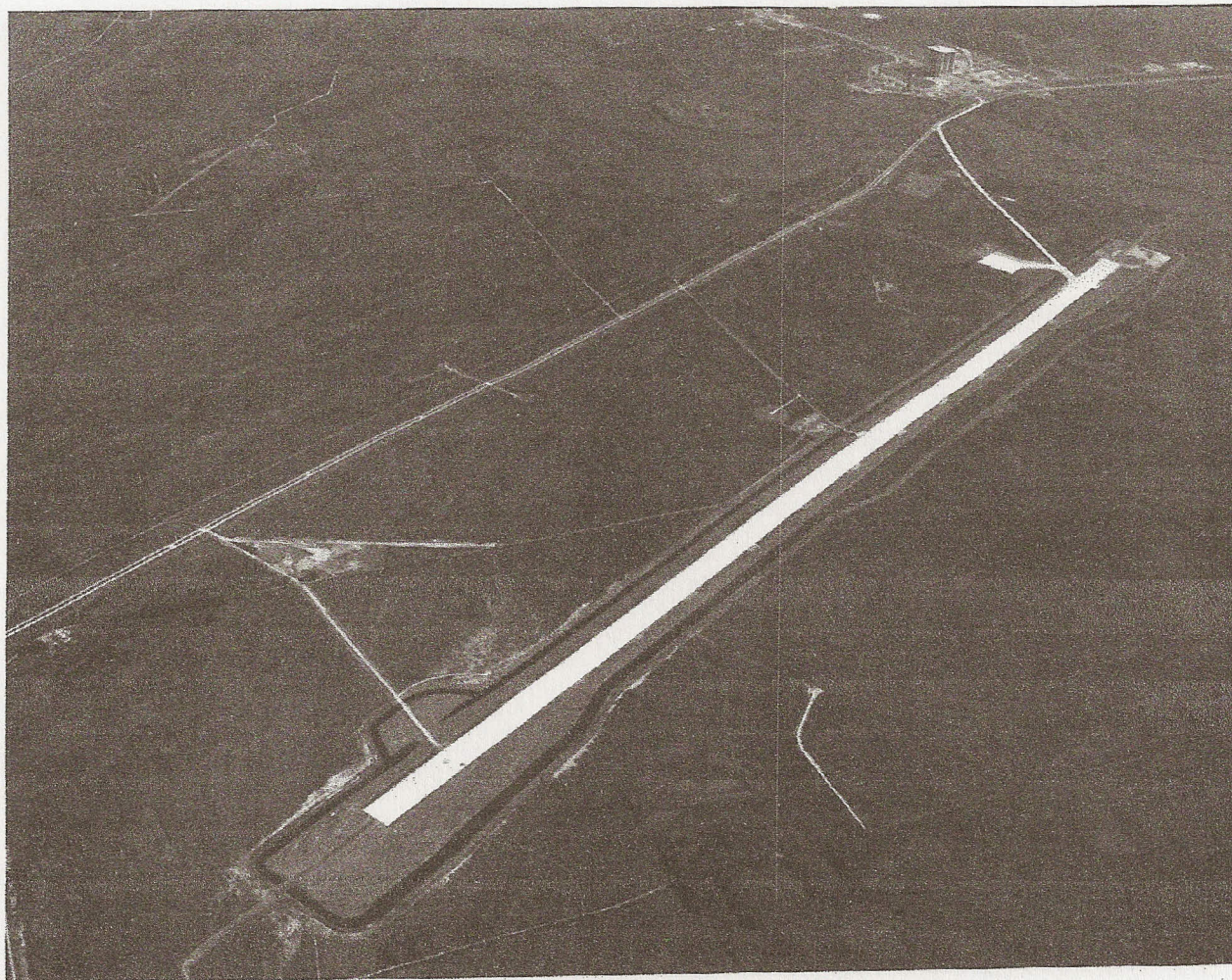

Figure 3-2.— Shuttle landing facility at KSC; the Vehicle Assembly Building is shown at the top right.

KSC OPERATIONS

Payload transportation

Payloads can be transported to the launch site by any means acceptable to the user. The launch site is capable of receiving payloads shipped overland or by air or water. One method of overland shipment that has been acceptable to spacecraft programs is by a commercial air-ride van provided with environmental control. Also, KSC operates the Payload Environmental Transportation System (PETS) on behalf of NASA and STS users. PETS has the capability to provide environmental protection for payloads during KSC highway transportation and can be adapted to support various payload containers.

Payload processing

Before mating with STS

Processing of a payload at the launch site can usually be divided into two distinct phases: those activities performed before the payload is mated with an STS element and those activities involving one or more of the STS elements (Shuttle vehicle, Spacelab, upper stage).

The typical operations that must be performed to ready a payload for launch on a Shuttle vehicle will vary according to the complexity of the payload, the technical disciplines involved, and the level of testing already done before the payload arrives at the launch site.

Because of the turnaround time constraint for preparing Space Shuttle Orbiters for launch, integration of payloads with the Orbiter will be limited to mandatory tasks. A payload element should be delivered to the launch site in as near flight-ready condition as is practical. Typical prelaunch operations include receiving, assembling, checking out, propellant servicing, and preparing for integration with other payload elements. Preparation and testing will not follow a fixed plan for all payloads.

The launch site activity plans must be established before arrival of a specific payload at the site to assure satisfactory completion of all flight-readiness preparations, including integration into a total cargo. The schedule will identify all major tests, all hazardous (systems) operations, interface verification, and all operations that require launch site services.

Individual payloads will be integrated into a single cargo before mating and checkout with the Orbiter. The integration testing of the total cargo will include

a Shuttle interface verification test, using the cargo integration test equipment, before the mating of cargo and Orbiter. This test is critical to the overall operation because Shuttle on-line operations assume compatibility between the cargo and the Shuttle system.

Customized STS/payload time lines, negotiated through the LSSM, will be part of the launch site support plan for a particular payload.

Mating of payload with STS

Those operations required to prepare the Orbiter for payload installation are performed in parallel with Orbiter systems checkout whenever possible. These payload-related operations include installation of any payload accommodations modification kits assigned for the flight. Then payloads/STS operations can begin.

Payload operations involving the Shuttle begin with the actual payload installation, either at the OPF or at the launch pad (using the RSS).

Payloads installed horizontally are transported to the OPF in the payload canister, which is environmentally controlled. They are hoisted into the cargo bay and secured. Interfaces are connected and verified. Then an Orbiter integrated test is conducted to complete the verification of interfaces between the payload and Orbiter. This test includes validation of payload data through Orbiter data systems, if applicable.

Prior to moving the Orbiter to the VAB (fig. 3-3), Orbiter power and purge capability is removed. The purge will not be available for approximately 35 hours. Power will not be available for the payload from the Orbiter during a 42-hour period after leaving the OPF until power is connected on the mobile launcher platform. There will also be a period of 21 hours from ordnance connection through transfers to the pad when Orbiter power will be off.

At the VAB, the Orbiter is hoisted to a vertical position, transferred to an integration cell, and lowered and mated to the external tank and solid rocket boosters. After the Orbiter aft umbilicals have been connected, a Shuttle interface test is conducted to verify vehicle/facility interface compatibility and readiness.

No payload activities will be performed in the VAB. Electrical power will not be available for payloads from the Orbiter during tow to the VAB, Orbiter erection in the VAB, and transfer to the launch pad.

The integrated Shuttle vehicle is transferred to the launch pad on the mobile launcher platform. The vehicle and platform are mated to the pad and the interfaces are verified.

Payloads that require vertical installations are moved to the launch pad in the payload canister and installed in the RSS prior to Orbiter arrival. After Orbiter arrival at the launch pad, the RSS is rotated into position next to the Orbiter and the payloads are installed in the Orbiter bay by the payload ground han-

dling mechanism (PGHM). Environmental control is maintained during the installation, and the Orbiter-to-payload interfaces are verified.

A launch-readiness test verifies the integrity of the pad/Shuttle/payload system interfaces for launch. Hypergolic, fuel cell cryogenic, and pneumatic systems are serviced, and countdown preparations are performed. Final countdown begins, the Shuttle cryogenic propellants are loaded, and the flightcrew boards.

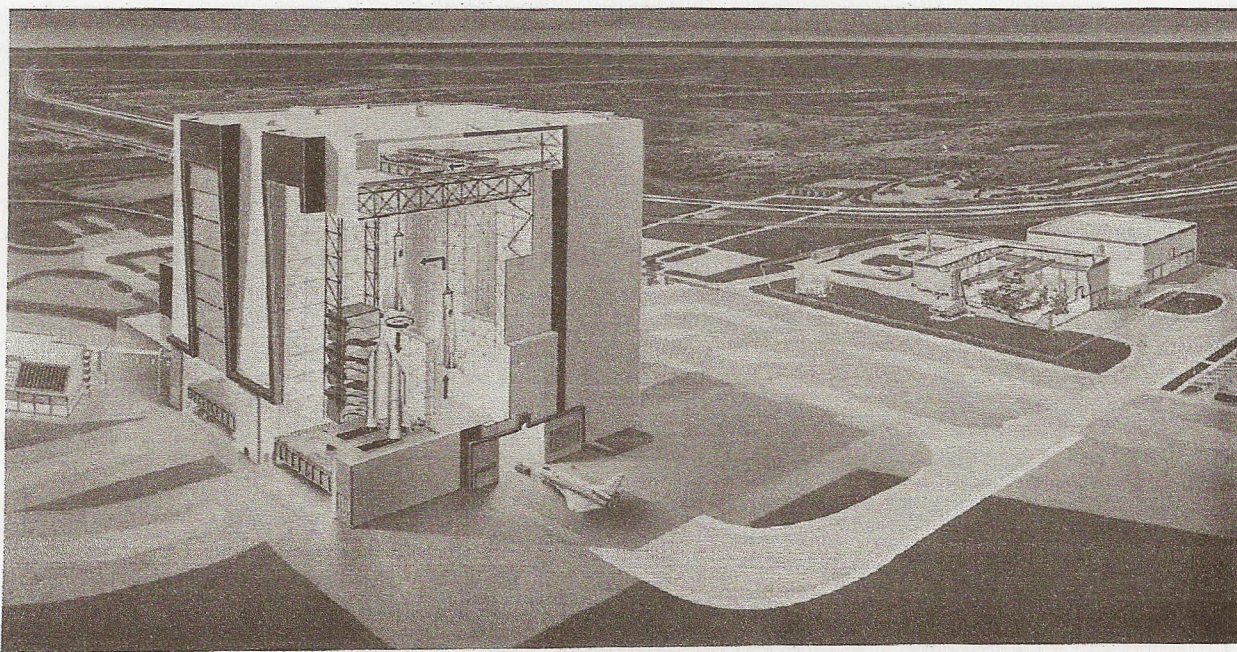

Figure 3-3.— Vehicle Assembly Building with adjacent Orbiter Processing Facility.

Spacelab ground flow

The major user responsibility in the ground processing flow of Spacelab is ensuring that the payload elements function properly.

The Spacelab ground operations concept is mission independent and is applicable to all payloads. Experiment activities that occur before the experiment end-item is mated to the Spacelab support systems or simulators are not affected by these processing operations.

NASA must perform the hands-on portion of the integration (and de-integration) at KSC for missions using NASA-provided Spacelab hardware, unless special expertise is required. In that event, the user can assist the NASA test team.

Unique ground-support equipment and test and servicing equipment must be provided by the user. This type of equipment should be held to a minimum

by making maximum use of Spacelab flight systems and ground-support equipment. Instrumentation system capabilities and sensors required to support ground test equipment must, if practical, be included in the flight experiment to minimize requirements for ground-support equipment. Ground-support equipment provided by the experimenter will be operated by the experimenter's personnel and will be scheduled and observed by the STS Spacelab processing team.

Access to the Spacelab exterior after it is installed in the Orbiter is through the cargo bay until the cargo bay doors are closed (fig. 3-4). While the Orbiter is still horizontal, limited internal access to the Spacelab pressurized module is available through the Orbiter cabin. At the pad/RSS where the Orbiter is in a vertical position, contingency access to both the interior and exterior is through the Orbiter cargo bay.

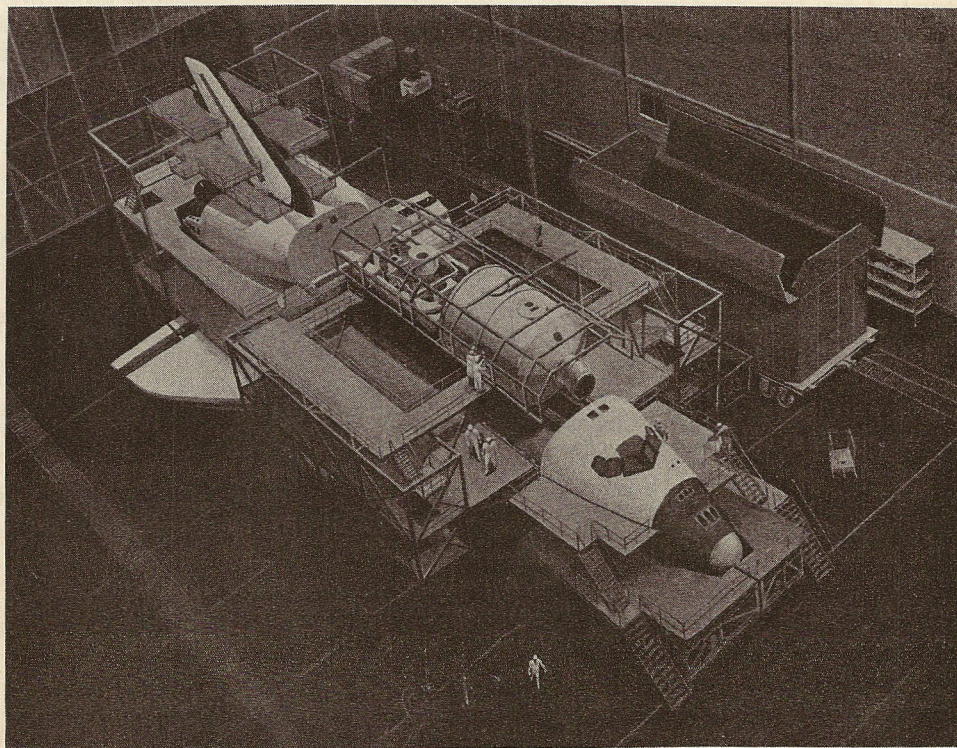

Figure 3-4.— Spacelab being installed in the Orbiter in the Orbiter Processing Facility.

Upper stages ground flow

Initial preparation of the upper stages is accomplished separately from their payloads (fig. 3-5). The upper stages consist of the inertial upper stage and the payload assist module.

Inertial upper stage

Buildup of the IUS takes place in the Solid Motor Assembly Building (SMAB) located at the Cape Canaveral Air Force Station. Receiving, assembling, and testing operations are conducted in the SMAB. The IUS reaction control system is sent to the Explosive Safe Area 60A Propellant Laboratory for loading and pressurizing and is returned to the SMAB for installation. Upon completion of IUS buildup and testing (with reaction control tanks installed), the IUS is moved to the Vertical Processing Facility (VPF) for mating with its payload and other cargo integration operations.

Payload assist module

Payload assist modules are of two sizes: a PAM-A designed for Atlas-Centaur class payloads and a PAM-D designed for Delta class payloads. The components for these stages, including their mounting cradles, are assembled in the Delta Spin Test Facility. Payloads requiring a PAM-D are mated to the PAM-D at the Delta Spin Test Facility, and the combination is then transported to the VPF for integration with other cargo elements. Payloads requiring a PAM-A are transported to the VPF independently and mated to the PAM-A before integration with other cargo elements.

Cargo integration at VPF

Upon arrival of payloads and upper stages at the VPF, their transporters, environmental covers or containers, and hoisting equipment will undergo cleaning operations in the airlock.

Processing of upper stages and payloads within the VPF will vary depending on the type of upper stage involved. A Delta class spacecraft mated with its PAM-D will be moved into the high bay where the environmental cover will be removed. The PAM-D/payload combination will be visually inspected and then hoisted into the vertical payload handling device (VPHD).

A PAM-A will be moved into the high bay following cleaning in the airlock. The environmental cover will be removed, and the PAM-A will be rotated in its ground handling frame, inspected, and hoisted into the VPHD. An IUS will be moved into the high bay following cleaning in the airlock. The container lid and the inner cover will be removed, and the IUS will then be hoisted into the VPHD. The Atlas class (PAM-A) payloads and the IUS payloads will be moved into the high bay following cleaning in the airlock. Their transportation covers/containers will be removed, and the payloads will be hoisted into the VPHD for mating with their respective upper stages. Access equipment, filler plates, elevating platforms, and STS user-provided ground-support equipment will be installed to facilitate access, inspection, and testing of the cargo elements.

Prior to tests involving the entire cargo, payloads and upper stages may conduct stand-alone health and status tests using portable test equipment or via remote ground stations. Also, before connection to the cargo integration test equipment (CITE), power circuit tests will be conducted and a visual inspection will be made on all interface connectors. Following interface connector mating, a series of interface verification tests will be conducted using the CITE, which simulates the Orbiter interfaces. These tests will include the following:

- Power turn-on, health and status checks
- Power control from a remote ground station or from a simulated Orbiter power control panel
- Standard switch panel functional tests
- Tilt table and latch release tests
- Computer/sequence control interface tests
- Communications/data interface tests
- Spacecraft command and monitor checks
- Mission simulation test
- End-to-end tests if required
- Ordnance systems test

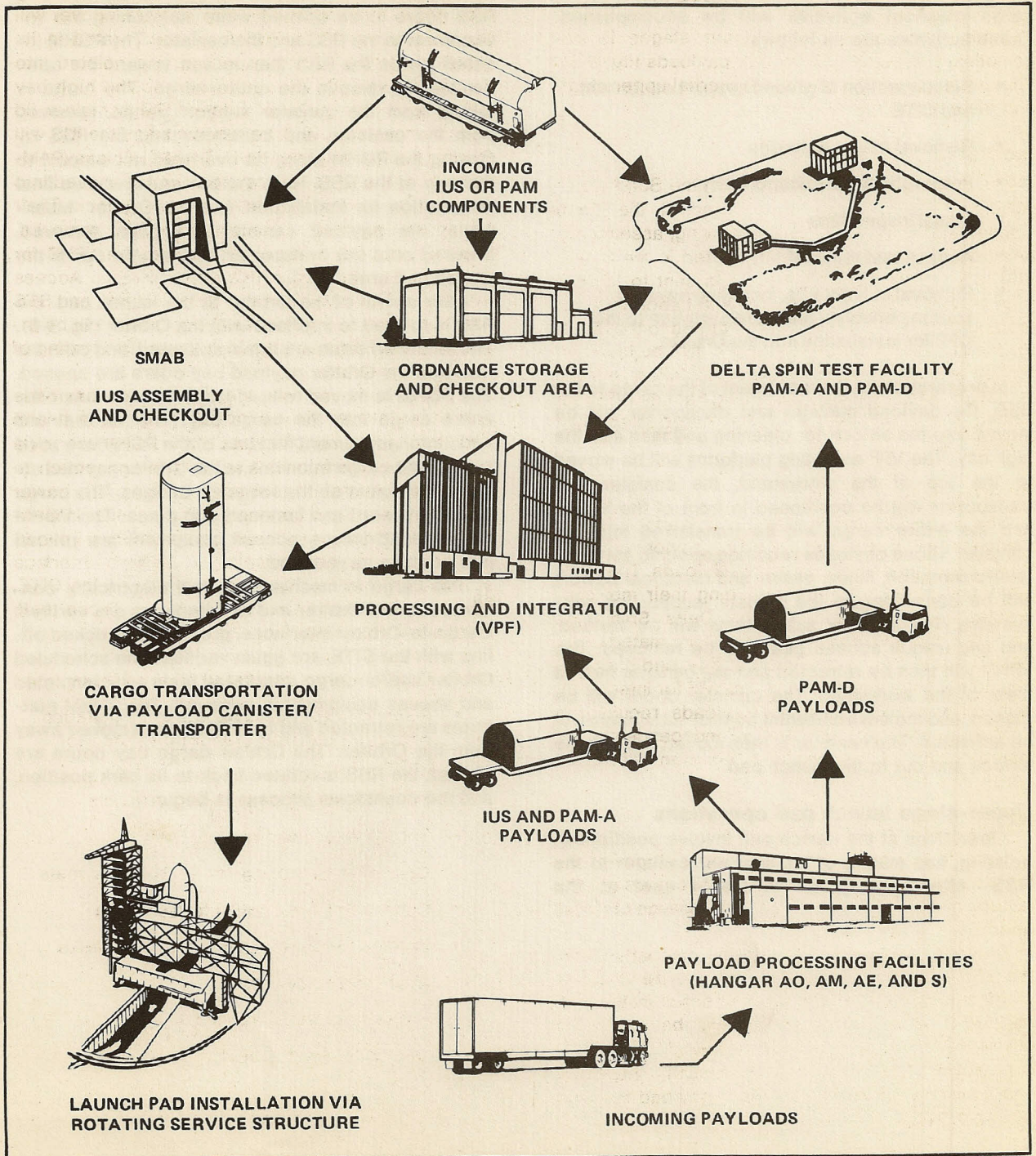

Figure 3-5.— Typical ground operations involving upper stages, from arrival at KSC through launch.

Following completion of testing using the CITE, cargo closeout activities will be accomplished. These activities are as follows:

- Disconnection of ground support equipment and CITE
- Removal of test batteries
- Preparations for transportation
- Visual inspections
- Access test removal
- Removal of flight kits, including payload station consoles, and transportation to the OPF for installation into the Orbiter

In preparation for the movement of the cargo to the RSS, the payload canister and transporter will be moved into the airlock for cleaning and then into the high bay. The VPF elevating platforms will be moved to the top of the workstand, the canister and transporter will be positioned in front of the VPHD, and the entire cargo will be transferred into the canister. Those payloads requiring specific services (instrumentation, fluids, gases, and electrical power) will be connected to the canister-supporting subsystems. The canister subsystems will be verified, and any unique access gear will be removed. The VPHD will then be retracted and the canister moved clear of the workstand. The canister doors will be closed, and the environmental control subsystem will be activated. The canister is then moved through the airlock and out to the launch pad.

Upper-stage launch pad operations

Operations at the launch pad involve positioning, hoisting, and mating of the payload canister to the RSS. After mating, an inflatable seal at the

canister/RSS interface permits both the canister and RSS doors to be opened while maintaining the environment in the RSS and the canister. The PGHM located inside the RSS then moves toward the open canister to remove the entire cargo. The cargo is raised from the canister support points, removed from the canister, and translated into the RSS by moving the PGHM along its overhead rail support to the rear of the RSS. Here the payloads receive final preparation for installation into the Orbiter. Meanwhile, the payload canister has been removed, lowered onto the transporter, and moved out of the launch pad area.

After arrival of the Orbiter at the launch pad, the RSS is rotated to interface with the Orbiter (fig. 3-6). The inflatable seals are again activated, and both the RSS and the Orbiter payload bay doors are opened. The PGHM is moved toward the Orbiter to insert the entire cargo into the cargo bay. The vertical and horizontal adjustment features of the PGHM are used to align the cargo trunnions to the Orbiter payload attachment points on the longeron bridges. The cargo is then lowered and fastened into place. The PGHM and payload-unique access equipment are placed into position as required.

The cargo is mechanically and electrically connected to the Orbiter and all interfaces are verified. Cargo-to-Orbiter interfaces, previously checked off-line with the CITE, are again verified. The scheduled Orbiter and/or cargo integrated tests are completed and access equipment is removed. The PGHM platforms are retracted and the PGHM's are moved away from the Orbiter. The Orbiter cargo bay doors are closed, the RSS is rotated back to its park position, and the countdown process is begun.

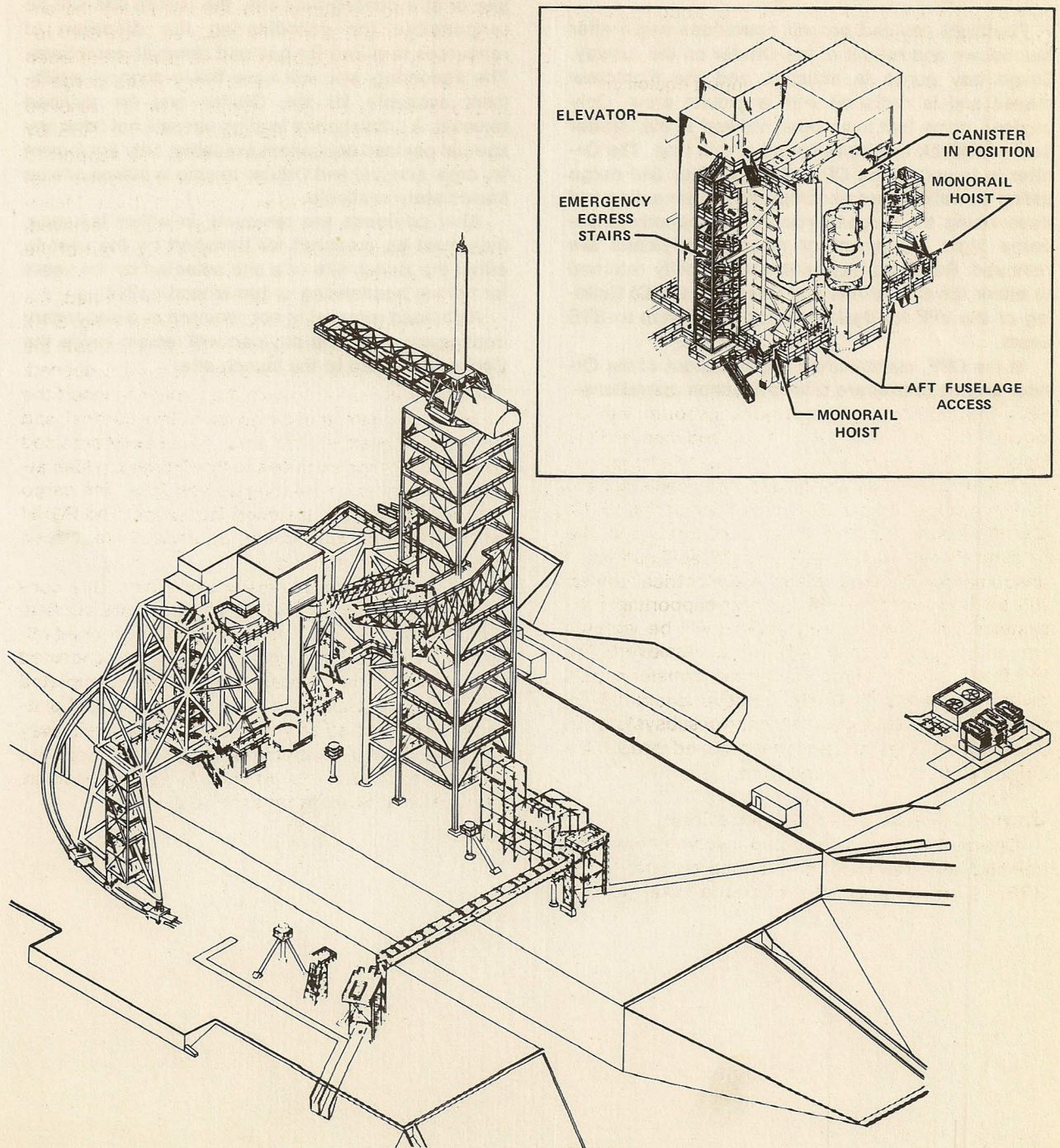

Figure 3-6.— Rotating service structure in the position for payload transfer into the Orbiter. No Space Shuttle is on the launch pad so all structures can be seen. The inset shows a cutaway canister in the RSS.

Postflight handling

Postflight payload ground operations begin after touchdown and rollout of the Orbiter on the runway. Cargo bay purge is initiated, and the flightcrew leaves and is replaced with a ground crew. Only payload items that have been stowed in the Orbiter cabin middeck can be removed at this time. The Orbiter is towed to the OPF where Orbiter and cargo safing operations are accomplished. After safing and deservicing, the cargo bay doors are opened and airborne flight equipment or returned payloads are removed. Removed payloads are normally returned to either the Operations and Checkout (O&C) Building or the VPF for de-integration and return to STS users.

In the OPF, maintenance and checkout of the Orbiter begins to prepare it for prelaunch operations.

In the event of an Orbiter landing at the secondary site or at a contingency site, the launch site will be responsible for coordinating the dispatch of resources required for payload removal operations. The secondary site will have basic support equipment available for the Orbiter and for payload removal. A contingency landing site will not have any special payload equipment available; only equipment for crew survival and Orbiter towing is planned to be immediately available.

After payloads are removed, in either instance, they must be prepared for transport by the user to either the launch site or a site selected by the users for normal postlanding or turnaround activities.

If payload removal is not required at a secondary contingency site, the payload will remain inside the Orbiter for return to the launch site.

KSC FACILITIES AND SERVICES

Buildings and test areas

The payload assembly and test areas, launch complexes, and other specialized facilities will be used for payloads during prelaunch preparations (fig. 3-7). The user can obtain detailed information about the facilities required from the launch site support manager. The LSSM will ensure that appropriate facilities are assigned to meet individual needs.

Various specialized facilities are intended primarily for processing of payloads before they are mated to the STS. Others are primarily for processing STS elements (Orbiter, Spacelab, upper stages) or for payload integration and simulated Orbiter interface verification. Both categories are summarized in tables 3-1 to 3-3.

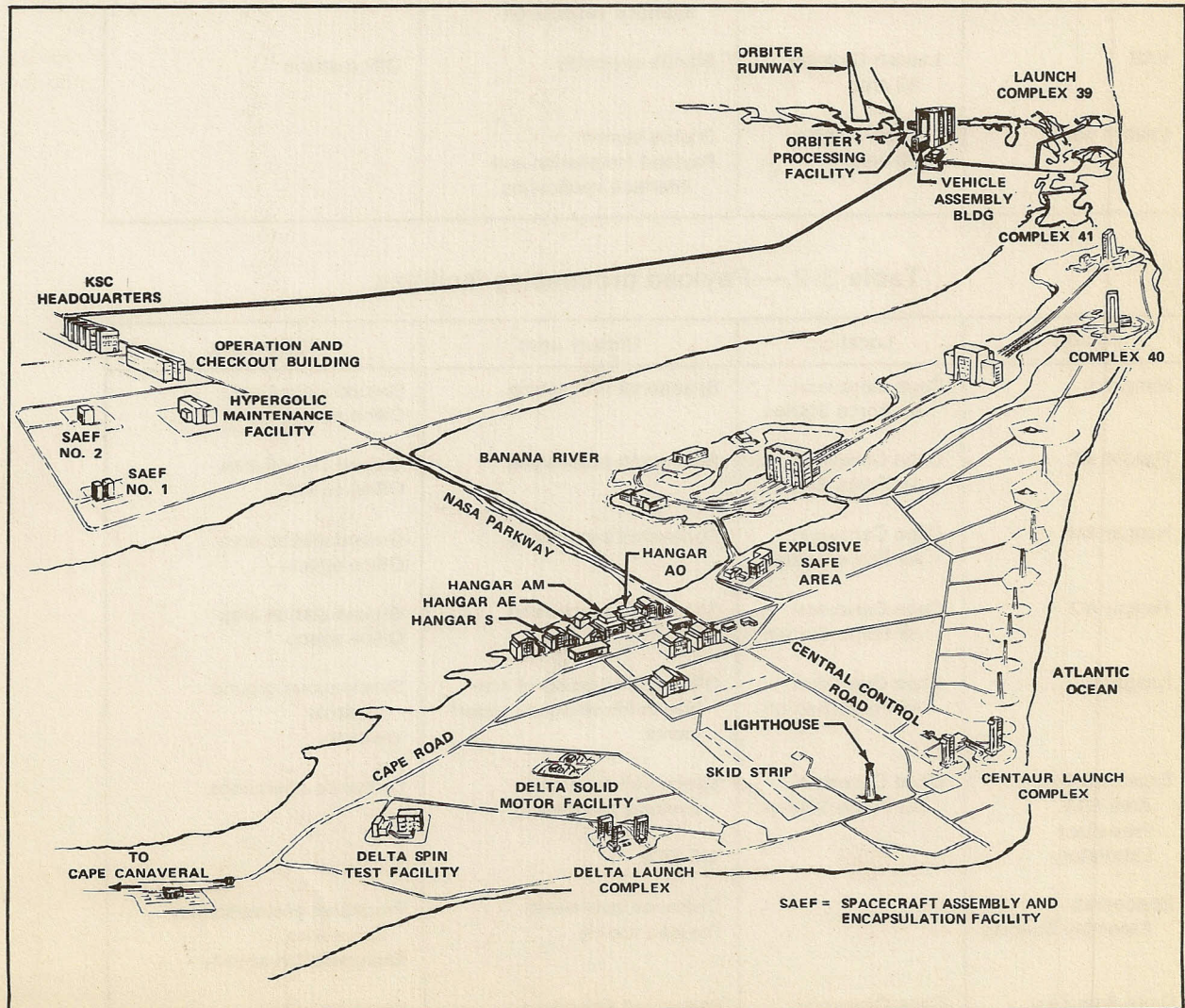

Figure 3-7.— Kennedy Space Center.

Table 3-1.— STS processing facilities

Facility	Location	Primary uses	Other uses
O&C Building	KSC Industrial Area	Spacelab refurbishment Spacelab processing Horizontal cargo integration Spacelab payload integration	Special-purpose laboratories Office space
VPF	KSC Industrial Area	Vertical cargo integration	
OPF	Launch Complex 39 area	Orbiter refurbishment Payload installation and interface verification	
VAB	Launch Complex 39 area	Shuttle assembly	Office space
Launch pad	Launch Complex 39 area	Shuttle launch Payload installation and interface verification	

Table 3-2.— Payload processing facilities

Facility	Location	Primary uses	Other uses
Hangar S	Cape Canaveral Air Force Station	Spacecraft processing	Ground station area Office space
Hangar AE	Cape Canaveral Air Force Station	Spacecraft processing	Ground station area Office space
Hangar AM	Cape Canaveral Air Force Station	Spacecraft processing	Ground station area Office space
Hangar AO	Cape Canaveral Air Force Station	Spacecraft processing	Ground station area Office space
Hangar L	Cape Canaveral Air Force Station	Off-line processing of non- human life sciences experi- ments	Synchronous ground controls Vivarium
Explosive Safe Area 60A Propellant Laboratory	Cape Canaveral Air Force Station	Spacecraft hazardous systems processing IUS RCS	Ordnance operations
Spacecraft Assembly Building		Ordnance operations Payload fueling	Propellant pressurization operations Encapsulation activity
Delta Spin Test Facility	Cape Canaveral Air Force Station	Spacecraft hazardous systems processing	Spin balancing

Table 3-3.— Facility environments^a

Location	Temperature, °F (K)	Humidity, percent	Clean room, class ^b
Hangar S Clean rooms Systems test area	72 ± 3 (295 ± 1.7) 76 ± 3 (297.6 ± 1.7)	45 ± 5 50 ± 5	100 000
Hangar AO High bay	75 ± 2 (297 ± 1.1)	45 ± 5	100 000
Hangar AE Clean room	72 ± 3 (295 ± 1.7)	45 ± 5	10 000
Hangar AM High bay	75 ± 3 (297 ± 1.7)	45 ± 5	Clean work areas
Hangar L	75 ± 3 (297 ± 1.7)	50 ± 5	100 000
Explosive Safe Area 60A Spacecraft Assembly Building	73 to 95 ± 3 (296 to 308 ± 1.7)	50 ± 5	100 000
Propellant laboratory Instrument laboratory	73 ± 3 (296 ± 1.7) 76 ± 3 (297.6 ± 1.7)	50 ± 5 50 ± 5	100 000
Delta Spin Test Facility	75 ± 5 (297 ± 2.8)	50 ± 5	Clean work areas
O&C Building	75 ± 2 (297 ± 1.1)	60 percent max.	100 000
VPF Airlock and high bay	75 ± 3 (297 ± 1.7)	45 ± 5	Clean work areas
SAEF-2 Airlock, high and low bay	75 ± 3 (297 ± 1.7)	45 ± 5	100 000
VAB	Not controlled	Not controlled	Not controlled
OPF high bay	75 ± 3 (297 ± 1.7)	50 (max.)	100 000 (inlet)
Launch pad	Not controlled	Not controlled	Not controlled
Rotating service structure	70 ± 5 (294 ± 2.8)	30 to 50	5000 (inlet)

^aAll figures represent design specifications; in some facilities, actual conditions could vary because of ambient conditions and the nature of the operations being conducted.

^bFederal Standard 209B, April 24, 1974, Clean Room and Work Station Requirements for Controlled Environments.

Cargo support equipment

A variety of equipment is used at the launch site to handle Orbiter cargoes. This equipment is used to handle and transport entire Orbiter cargoes during on-line STS processing; i.e., between the O&C Building and the OPF or between the VPF and the RSS. Unique payload ground-support equipment must be provided by the user and should be identified, controlled, and funded by the user. Facility interfaces to payload-unique equipment should be planned with the LSSM.

Payload-handling equipment

Those items in the basic hardware inventory for payload handling that will be needed by most users include payload-handling fixtures (strongbacks), payload canisters, and canister transporters.

Strongback

The strongback (figs. 3-8 and 3-9) is a rigid frame device consisting of beams, cables, attachment hook

devices, and rings. It is adjustable to accommodate varying lengths and shifting centers of gravity of payloads up to the maximum for an Orbiter payload. The strongback will interface with the payload so that it will not interfere with engagement and load transference to attachment/retention points. It will not induce any bending or twisting loads on any payload element.

Payload canister

The canister (fig. 3-10) is equal in size and configuration to the Orbiter cargo bay, including similar doors on the top. Service panels, tiedowns, and lift points are also part of the canister to allow rotation of the container. Special platforms for personnel access to the open canister can also be used. This equipment consists of a bridge-type structure that spans the canister and has walkways along each side of it. The bridge can be raised or lowered; at maximum elevation, it clears the payload envelope.

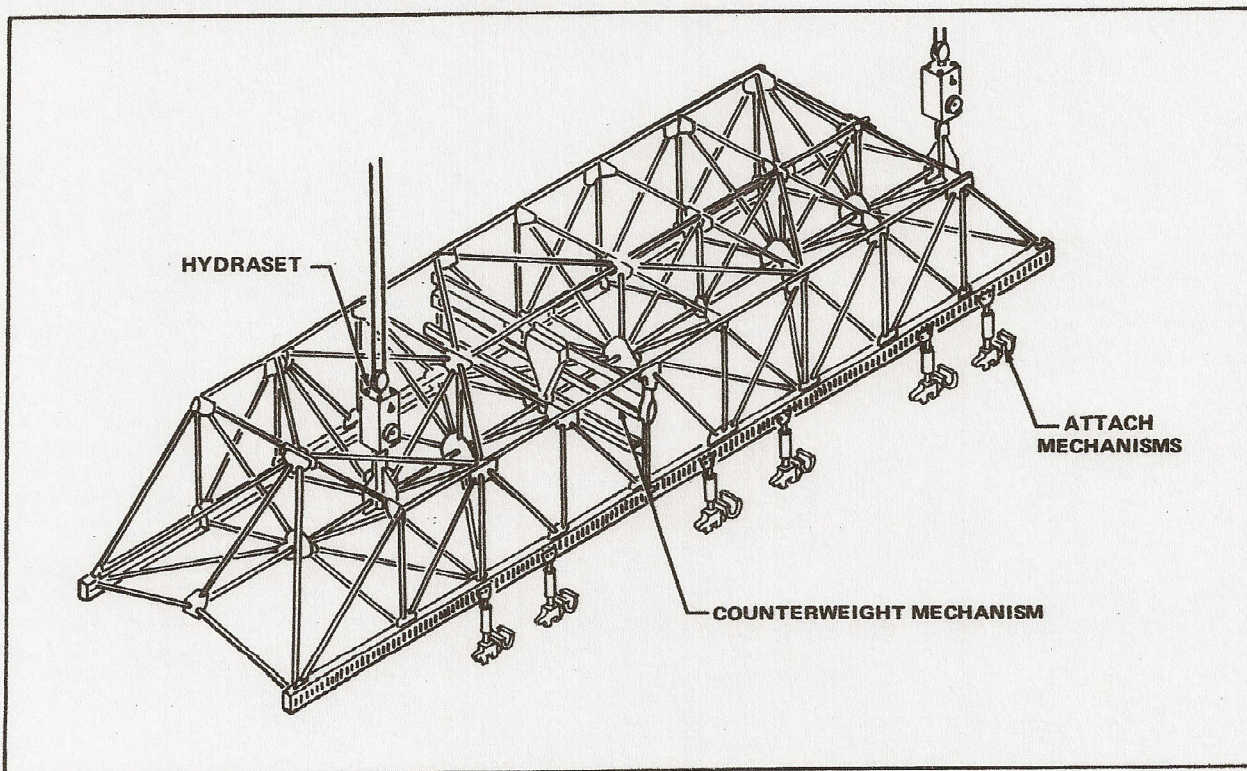

Figure 3-8.— Horizontal handling fixture (strongback) for payloads.

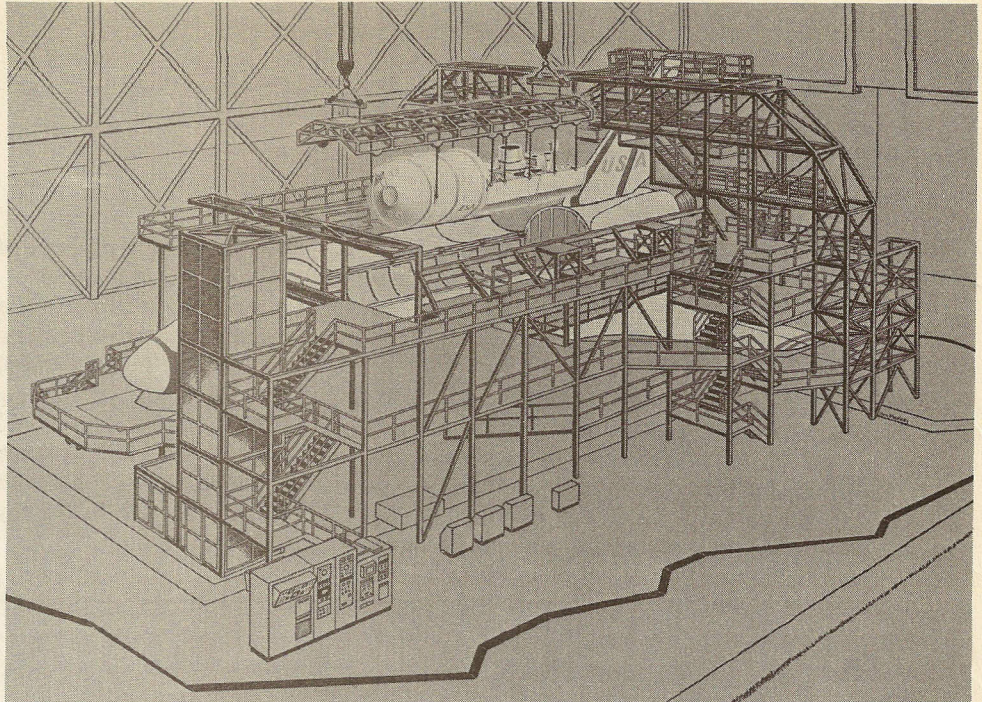

Figure 3-9.— Strongback in use for horizontal installation of Spacelab.

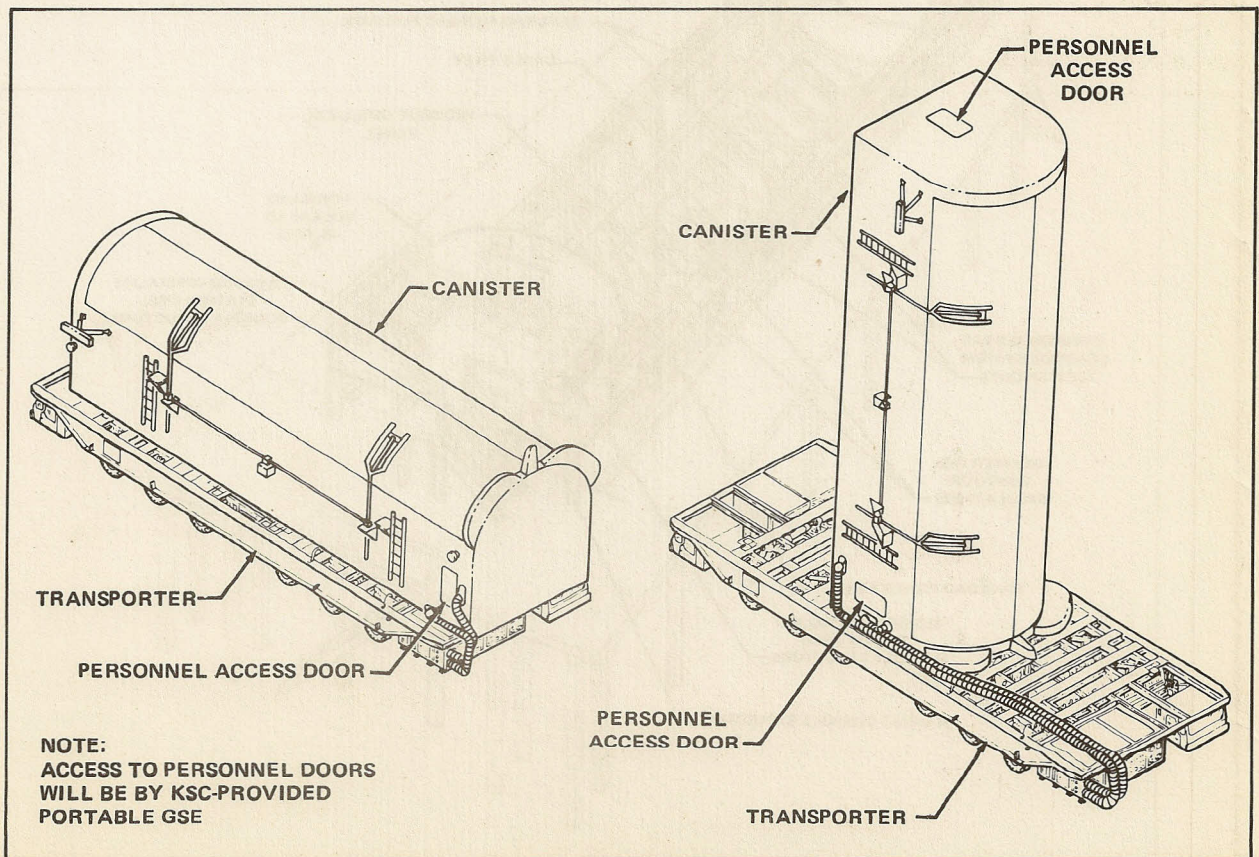

Figure 3-10.— Payload canister shown mounted on its transport.

Canister transporter

The transporter is capable of moving a fully loaded canister. Its suspension system helps to minimize shock and vibration.

Cargo integration test equipment

The cargo integration test equipment (figs. 3-11 and 3-12) has the capability to verify interfaces off-line, including payload-to-payload and cargo-to-Orbiter mechanical and functional interfaces. The CITE in the O&C Building can accommodate horizon-

tally processed cargoes. Vertical processing is done on the CITE in the VPF.

Included in this equipment are structural assembly stands, mechanical clearance and fit gages, electrical wiring, thermal-conditioning items, electronic test sets, and radiofrequency transmission equipment adapters. The CITE satisfies the STS requirement to perform final assembly and integrated testing of cargo before it is mated to the Shuttle. It may also be used to satisfy the payload interface verification requirements.

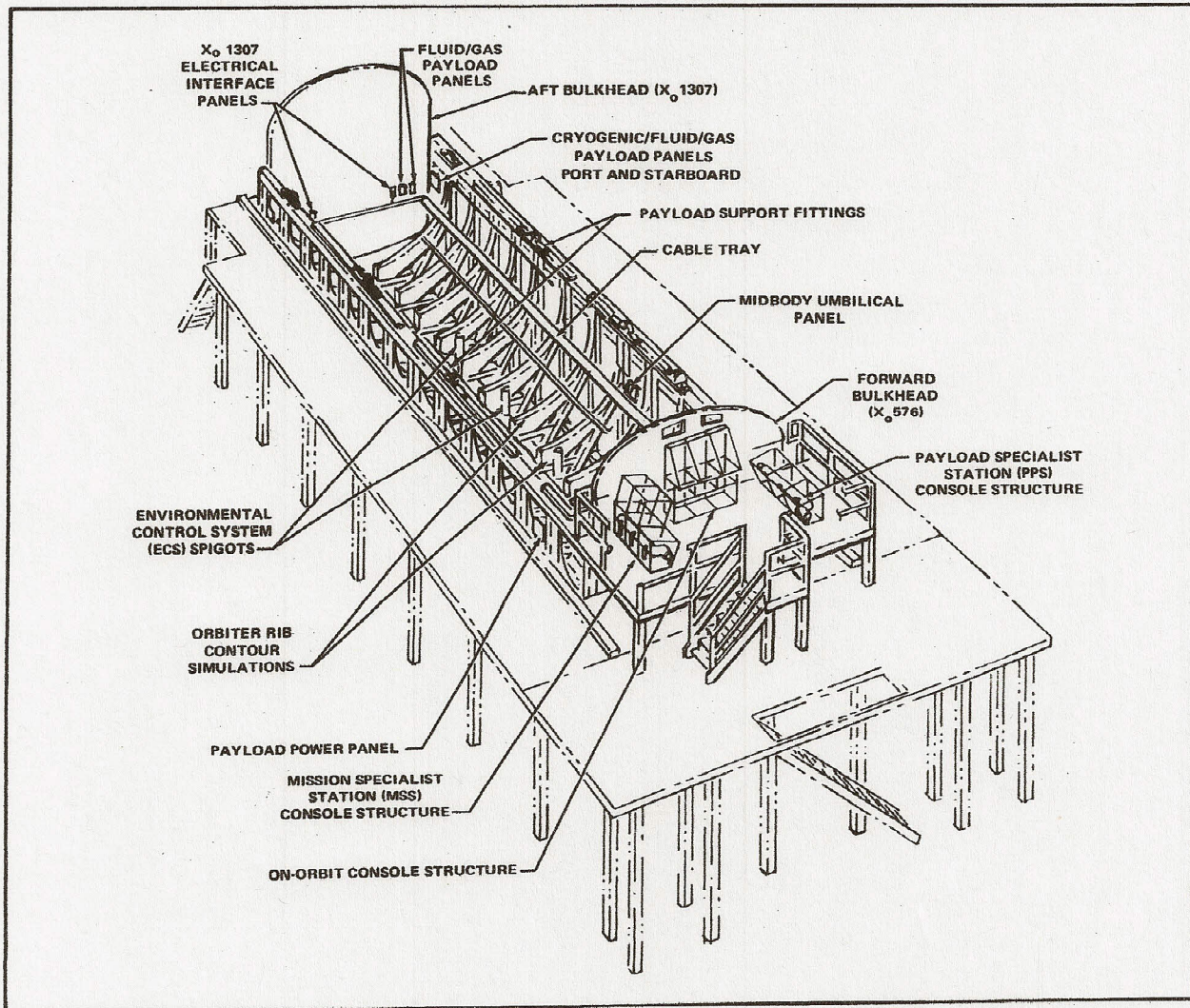

Figure 3-11.— Layout of cargo integration test equipment for horizontal cargo.

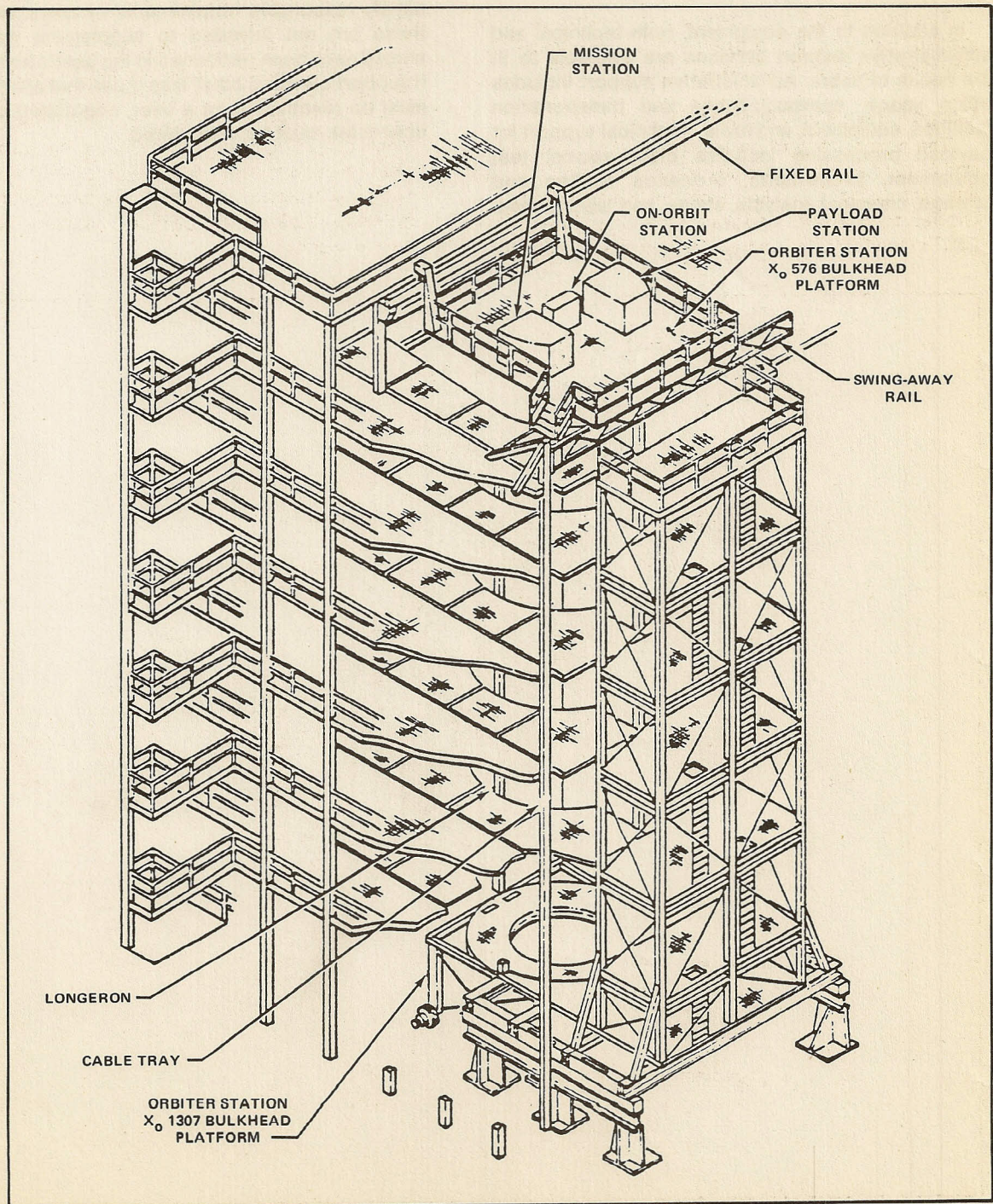

Figure 3-12.— Layout of cargo integration test equipment for vertical cargo.

Services

In addition to the equipment, both technical and administrative support services are available to fit the needs of users. Administrative support includes office space, communications and transportation facilities, equipment, and tools. Technical support for payload processing includes clean rooms, test equipment, propellants, ordnance testing and storage, chemical analysis, shops, and laboratories.

Complete technical services are available to satisfy reasonable requirements of users. However, these are not intended to supplement work that should have been performed in the user's home plant. If support services other than those that are standard must be reactivated for a user, negotiated cost and schedules must be considered.

KSC MANAGEMENT

Interfaces

Standard payload interfaces and services required at the launch site will be made available to all users, but the users will retain primary responsibility for performance and off-line processing of their payloads (fig. 3-13). To fulfill this host concept, the launch site staff must schedule and integrate facilities, support equipment, services, and personnel.

Planning launch site support for payloads will begin with the initial contact between the user and the designated LSSM. The LSSM will be assigned early in the program to lead the planning effort. When the planning is complete and the hardware arrives at

KSC, the cargo operations payload engineer will become the user's host. He will become acquainted with the user's organization and will work with that organization in defining launch site operations. Initial emphasis will be on long-lead items, conditions that might affect payload design, and resolution of problems that pose potential difficulties. Any new capabilities required must be evaluated for cost and schedule effects. Even if payload processing requirements are incomplete, they should be submitted at the earliest possible date to allow ample time for evaluation, planning, and integration into the STS processing.

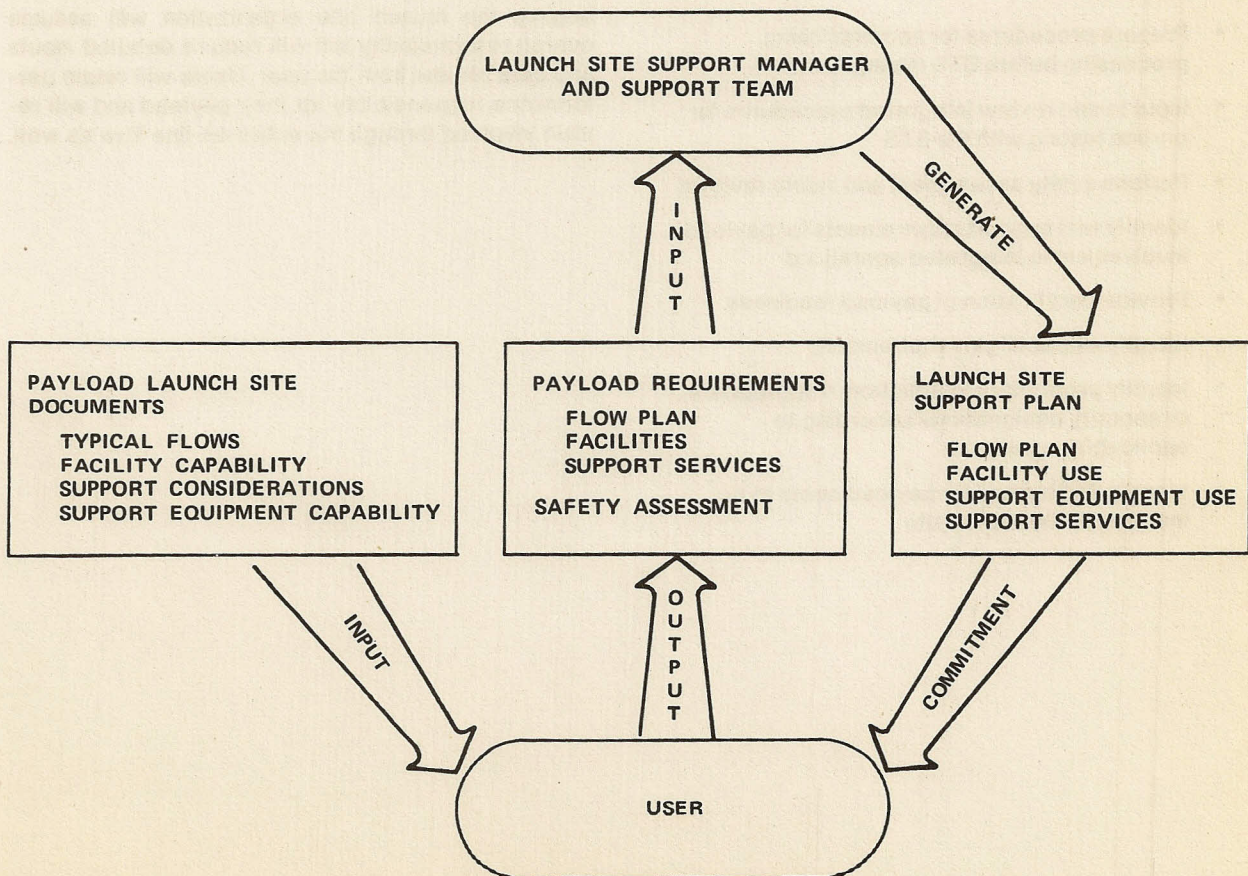

Figure 3-13.— User's involvement in planning launch site operations with the LSSM for a specific payload prior to hardware arrival at KSC.

Responsibilities

During planning, the user, using the KSC Launch Site Accommodations Handbook, has the responsibility to:

- Establish specific processing flow requirements
- Identify facility services required
- Identify payload-supplied support equipment required for use at the launch/landing site
- Identify activation/deactivation requirements associated with unique support equipment
- Ensure reliability and quality assurance during the off-line processing in support of payload readiness
- Prepare procedures for accomplishing processing before STS mating
- Input to and review integrated procedures for on-line testing with the STS
- Perform safety assessment and safety reviews
- Identify test support requirements for payload involvement in integrated operations
- Provide certification of payload readiness
- Identify all postflight requirements
- Identify proprietary information, if appropriate, or security designations according to applicable regulations
- Identify and budget for payload costs to be incurred at the launch site

After hardware arrival at KSC, the launch site organization (cargo operations) will be responsible for providing assistance to the user for planning integration and checkout of the payload elements with the STS, planning and scheduling facility use and payload flow, ensuring that all payload requirements are met, and conducting the launch operations. Users must provide sufficient documentation to define all requirements for their payloads at the launch site.

For complex payloads (particularly those requiring major construction of facilities at the launch site), planning should begin several years before the payload is scheduled to arrive at the launch site. Most payloads, however, will require significantly shorter lead times.

The user will retain prime responsibility for off-line operations involving only his hardware. Once integration with other payloads or STS hardware begins, the launch site organization will assume overall responsibility but will require detailed inputs and data review from the user. Users will retain performance responsibility for their payload and will remain involved through the entire on-line flow as well.

SAFETY CONSIDERATIONS

The safety program at the launch site is intended to protect personnel and the public from hazards, to prevent damage to property, to avoid accidental work interruptions, and to provide data with which to evaluate risks and loss factors. The launch site safety program is part of the overall STS safety program.

At KSC, the director of safety, reliability, quality assurance, and protective services is responsible for safety planning. Safety requirements at KSC include Department of Defense requirements. Those NASA operations in Air Force areas will be conducted in accordance with local Air Force safety regulations and within the framework of KSC safety standards. Safety surveillance will be coordinated with Air Force representatives.

The user is responsible for applying the provisions of the safety program by:

- Maintaining surveillance in assigned areas to detect and correct unsafe practices and conditions
- Coordinating with the safety operations office on all matters pertaining to accident prevention
- Submitting the required safety data
- Ensuring that employees have and use safety clothing and equipment during hazardous operations
- Conducting safety reviews

A hazardous operation is one that could result in damage to property or injury to personnel because it involves one or more of the following.

1. Working area and environment: Any environment that deviates from normal atmosphere (in pressure, chemical composition, or temperature, for example, and including confinement within a closed spacecraft) or work in proximity to pressure vessels.

2. Explosive ordnance: Handling, transportation, installation, removal, closeout, or checkout of ordnance devices or an ordnance system.

3. Propellants: Loading, unloading, flow, hookup or disconnect, movement of loaded storage units, or opening contaminated systems involving solid, liquid, hypergolic, or cryogenic propellants.

4. Cryogenics: Loading, unloading, flow, hookup or disconnect, movement of loaded storage units, or repair of a system containing cryogenics.

5. Hoisting: Any operation involving lifting, loading, or transporting a large or heavy item.

6. Radiation: Any operation involving an ionizing radiation source or radiographic equipment or producing more than a specified level of radiofrequency radiation. Authorization at KSC for exposure to ionizing radiation is controlled centrally through the Radiation Safety Program. Rules are consistent with NASA, Energy Research and Development Administration, and State of Florida regulations.

7. Toxic/combustible/corrosive materials: Risks involved in the use of toxic, combustible, or corrosive liquids, gases, or solids, such as mercury, acids, or solvents.

8. Pressure: Operations involving the pressurization of systems or components in which the first pressurization of a vessel exceeds 25 percent of design burst; in which any pressurization of a vessel containing hazardous fluids exceeds 25 percent of design burst; in which any pressurization of a vessel exceeds 50 percent of design burst; or in which any pressurization of tubing, fittings, and other components exceeds 25 percent of design burst.

9. Electrical: Any operation involving risk because of the nature of the equipment involved.

10. Other: Any operation not previously specified that could endanger personnel or hardware (as examples, use of other high-energy sources or work at heights).

The safety operations office at KSC will review hazardous operating procedures. A variance from normal safety operations may be issued under certain circumstances.

VANDENBERG LAUNCH SITE OPERATIONS

At Vandenberg Air Force Base, the Department of Defense will be responsible for the general-purpose Shuttle equipment and facilities necessary to perform the ground, launch, and landing activities for all Space Shuttle operations. NASA KSC will be responsible for launch site support for all NASA and civilian payloads before they are mated with the Orbiter, while the U.S. Air Force at VAFB will be responsible for DOD payloads as well as for overall Shuttle facilities. The VAFB STS facilities are geographically separated into the North Base area and the South Base area (fig. 3-14).

Payloads will be installed either at the Orbiter Maintenance and Checkout Facility (OMCF) (in a manner identical to that at the OPF) or at the launch pad through the payload preparation room (PPR) or the payload changeout room (PCR) (figs. 3-15 and 3-16). The latter is DOD baseline. Vertical installations will differ slightly from those at KSC in that the preparation room is located on the launch complex

and the changeout room traverses some 775 feet (235 meters) between the preparation room and the launch mount. At VLS, the payload may be delivered to the NASA Payload Preparation Facility (PPF) or the preparation room for pre-integration tests and checkout. Cargo integration and verification are then performed in the preparation room by the DOD (with NASA participation when NASA-sponsored payloads are involved). The flight-ready cargo is then transferred into the changeout room, translated to the Orbiter, and mated for launch.

After the Orbiter lands, safing and deservicing are done in the Safing and Deservicing Facility (SDF). Returned payloads are removed at the Orbiter Maintenance and Checkout Facility. Shuttle operations at VLS are more fully described in the Vandenberg STS Project Plan, Mission Operations Plan, Volume 1, Ground Operations (SAMSO-LV-0020-1) and the NASA/VLS STS Payload/Cargoes Ground Operations Plan (K-CM-09.1).

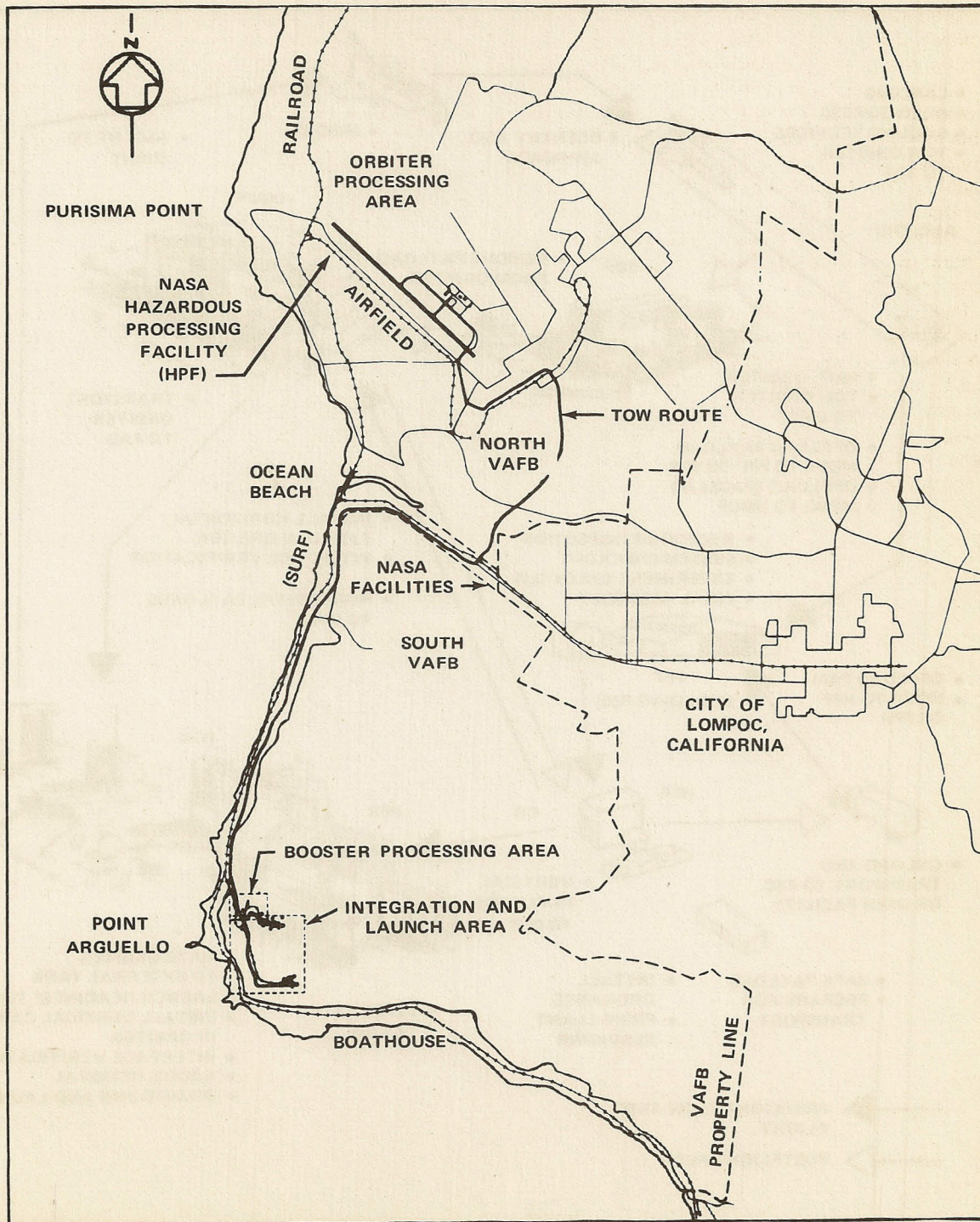

Figure 3-14.— Vandenberg Air Force Base.

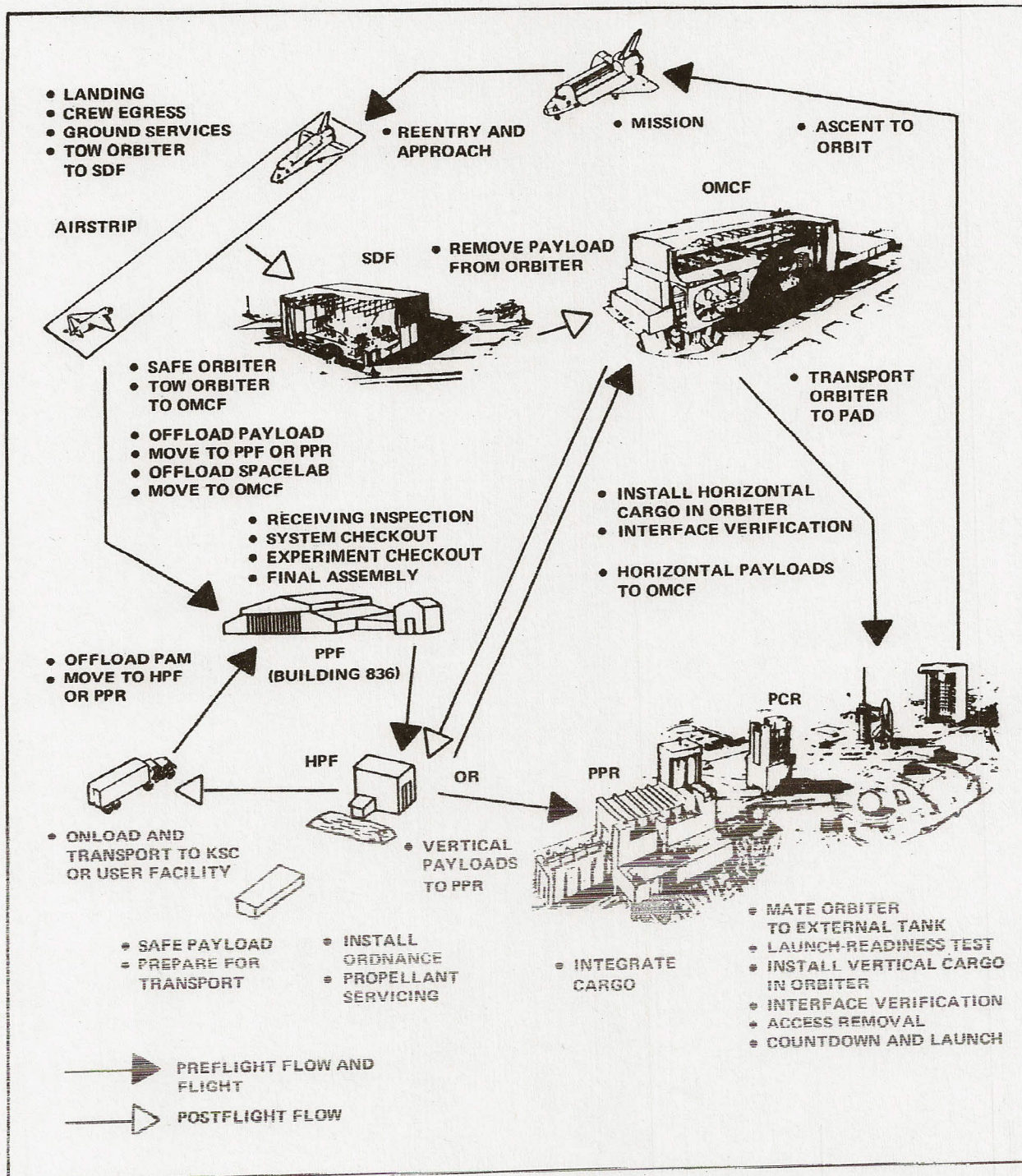
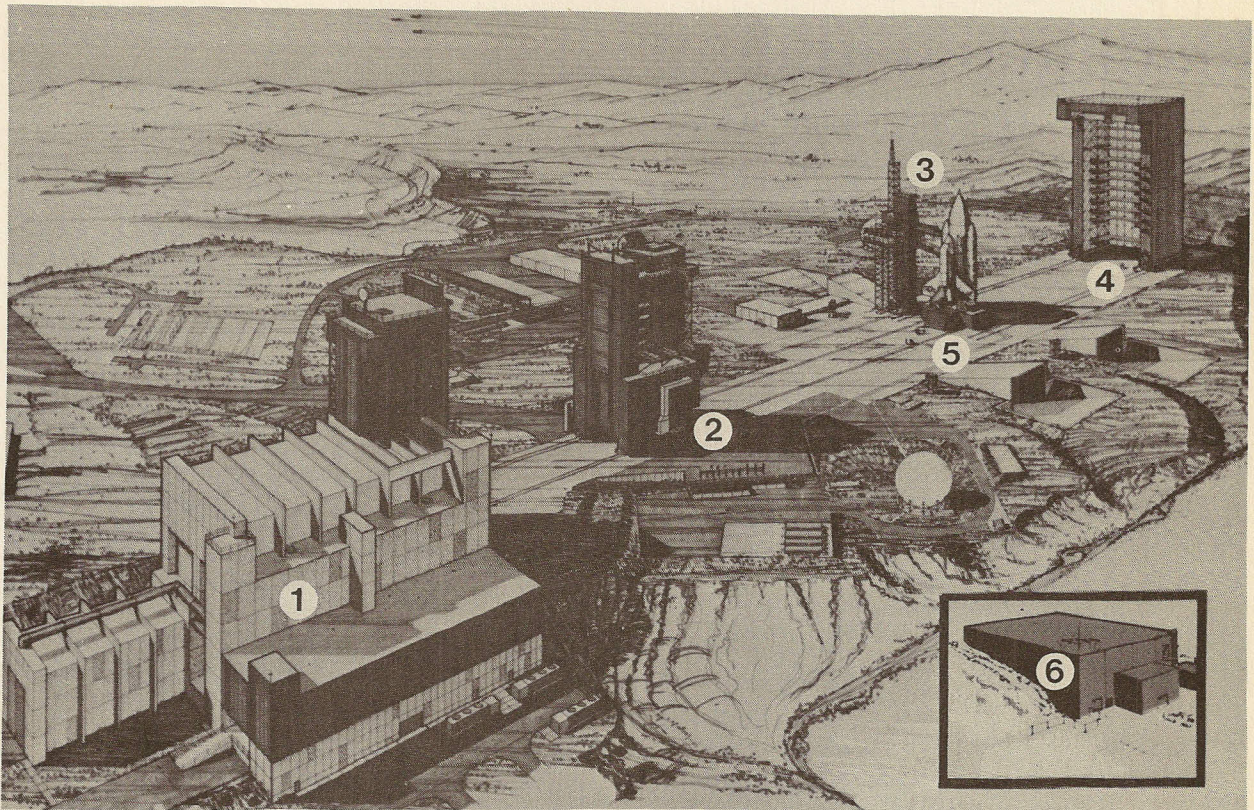

Figure 3-15.— Typical payload flow at VLS.



1 PAYLOAD PREPARATION ROOM (PPR)
 - PAYLOADS TO PPR

2 PAYLOAD CHANGEOUT ROOM

3 ACCESS TOWER
 - SOLID ROCKET BOOSTER FROM SRB REFURBISHMENT
 AND SUBASSEMBLY FACILITY
 - EXTERNAL TANK FROM ET PROCESSING AND STORAGE
 - ORBITER FROM ORBITER MAINTENANCE AND
 CHECKOUT FACILITY
 - FLIGHTCREW FROM FLIGHTCREW ACCOMMODATIONS

4 MOBILE SERVICE TOWER

5 LAUNCH PAD

6 LAUNCH CONTROL CENTER

Figure 3-16.— Launch pad integrated operations at VLS.

Flight design

The flight design activity encompasses trajectory, consumables, attitude and pointing, navigation, and deployment/retrieval planning. To minimize the requirement for unique and detailed planning and analysis, standardized flights will be used if they are consistent with the specified payload objectives. Also, consumables "envelopes" are utilized to avoid detailed analyses during early stages of flight planning. The standard planning approach involves sets of orbital destinations (inclination, orbital altitude), flight phases (launch, on-orbit time line, deployment/retrieval sequences), maneuver sequences (rendezvous, orbital adjustments, deorbit), and crew activity blocks. Analysis of electrical, communications, and environmental needs at this stage will lead to such decisions as whether to include various flight kits on the flight.

Based on the documented payload mission requirements for a given flight, the flight profile design will be initiated. The end result of the flight design phase is a detailed trajectory and flight profile that includes such information as maneuver sequences, vehicle attitude and pointing, consumables time lines, communications coverage, and lighting data.

The flight data system (FDS) was developed for the high flight rate environment to allow a systematic approach to flight design. This approach requires standardization and timely submittal of user inputs, and these are achieved by a controlled user/STS interaction through the PIP/annex development process.

Modular software and standard flight phases will be used to assemble the flight trajectory from launch to landing. After evaluation and alterations of the flight trajectory have been made, a flight profile will be produced. The conceptual flight profile will be baselined at the time of the cargo integration review (CIR) and will become the basis for all detailed planning activities. For complex flights, the CIR will be scheduled approximately 18 months before flight. For routine flights, the CIR will be scheduled closer to flight and standard flight design products will be utilized.

Occasionally, a change in flight requirements, cargo manifest, or launch schedule may require modification of the flight profile.

During the period beginning about 16 weeks before the launch, detailed flight design data are generated to develop an operational flight profile and

to support any necessary consumables loading parameters and crew activity plans.

Crew activity planning

A time line plus the necessary procedures and crew reference data to accomplish a given flight are generated from crew activity planning.

During the early planning phase, crew activity planners support the analysis of mission compatibility and flight feasibility in relation to crew activities. The crew activity aspect of early planning will result in definition of the flight duration and crew size and identification of any new technique or procedure requirements.

Beginning with support to the CIR about 18 months before the flight, a preliminary integrated summary crew activity plan is prepared to support an assessment of cargo feasibility. Preliminary PIP Flight Planning Annex information is the basis for early STS planning.

Crew activity planners will also support payload crew activity planning. The users are responsible for performing the experiment planning, scheduling, and trade-offs necessary to accomplish the payload flight requirements. The STS operations center is responsible for performing the STS planning and STS activity scheduling necessary to support payload activities and to maintain crew and vehicle safety.

About 1 year before launch, the payload/STS flight data requirements are baselined. This activity serves as a checkpoint to determine which length planning cycle is warranted and it establishes the following:

- STS procedures and reference data
- STS/payload interface procedures and reference data
- Payload procedures and reference data
- Time lines and crew activity plans

If new STS procedures are identified in the requirements for STS/payload interface procedures, the longer planning cycle is warranted, and development of these procedures will begin and will continue until approximately 16 weeks before launch when the Preliminary Flight Data File is published.

The summary STS time line, which contains the crew activities for the STS flight phases (launch, rendezvous, entry, etc.), crew work/rest cycles, and crew personal and system-maintenance periods, is developed. The summary STS time line, in combination with the flight profile, serves as a baseline for experiment planning and scheduling.

The payload time line will be developed by payload crew activity planners, leading to a summary payload time line that is consistent with STS constraints and schedules and with the scientific activities necessary to accomplish the payload flight requirements. Some modifications to the STS activities may be needed to accommodate the payload flight requirements within the planning resources limits, while maintaining STS vehicle and crew safety limits.

The STS crew activity planners will combine the payload activities (which have been planned and scheduled by the payload crew activity planners) with the STS activities to create a single integrated summary crew activity plan. Those STS activities required to support the payload activities will also be scheduled. As a part of this integration process, a vehicle attitude time line will be developed. The STS/payload integrated summary crew activity plan (CAP) becomes the baseline from which all detailed STS and payload crew activity planning and procedures development is accomplished. The user is responsible for the development of all payload detailed crew activity planning and payload procedures development. The STS operations center is responsible for all detailed STS crew activity planning, all STS procedure development, and all STS payload procedures integration.

During this time frame, an update to the flight profile is produced, if required, and detailed systems analyses are conducted. This is necessary because of the interrelationships among flight design, operations planning, and crew activity planning.

These products are used to develop the payload planning details. The payload details consist of any required payload time-line details that go beyond the basic activity definitions in the summary crew activity plan, or any payload data required for the execution of these activities. If modifications to the integrated summary crew activity plan are required, they will be coordinated with the STS crew activity planners.

About 8 weeks before launch (6 weeks in the short planning cycle), the Payload Flight Data File will be

completed. At approximately 8 weeks, the final STS Flight Data File will be produced by the STS planners. This is the material actually carried onboard and includes the crew activity plans, procedures, reference material, and test data needed by the crew for flight execution.

During this same time frame, the STS operations planners will produce the final issues of the command plan, flight rules, and network and logistics support plan. This will allow the crew and the STS flight control team (assigned about 8 weeks before launch) to begin their flight-specific training and will serve as a basis for their preparations.

The majority of STS procedures are standardized; changes required from flight to flight will be primarily a result of vehicle configuration changes. The STS/payload interface procedures, however, are candidates for standardization only for repeat payloads. The scheduling of STS payload support activities depends on the payload activities themselves. For this reason, standardization in these areas is very difficult (without sacrificing flexibility in payload scheduling or accepting less than optimum results).

Operations planning

Operations planning includes that planning performed to ensure compliance with mission objectives. The results of the analyses performed during the early planning and flight design phases are the primary inputs to the operations planning phase.

During this final phase, the documentation to be used during flight operations is evaluated and updated no later than 12 weeks before launch if the flight requirements demand modifications. The following documents are involved.

- Flight rules
- Console handbook
- Command plan
- Communications and data plan
- Systems schematics
- Mission Control Center (MCC)/network support plan
- Logistics support plan
- Countdown test checkout procedures
- Systems command procedures handbook
- Flight data file
- Orbiter systems operating procedures
- Payload systems operating procedures

Detailed systems and consumables analyses and budgets for the flight, using the reference trajectory as a basis, are also done in this final planning phase.

Training preparation

The training preparation task for a specific flight begins with the determination of training requirements. If new facilities are needed, they must be identified far enough in advance to allow funding and design work.

Once the training requirements have been identified, standardized training plans will be modified to fit the flight requirements, the training facilities will be scheduled, the simulation scripts written, and the actual training performed to support both flightcrew and flight controller tasks.

All STS-related training, both for onboard and ground personnel, is the responsibility of the NASA Lyndon B. Johnson Space Center (JSC). All payload-related training is the responsibility of the user. Close coordination is required to achieve a compatible and balanced training plan.

Additional information about schedules, requirements, and specific facilities is included in the section entitled "Training and Simulations."

COMMUNICATIONS NETWORK

The network used by the Space Transportation System provides real-time communication links between the user on the ground and his payload—whether it is attached or detached—during most of the time on orbit. The communication links provide the capability for downlink telemetry data, uplink command data, two-way voice, downlink television, and uplink text and graphics (fig. 4-2).

The STS communications network is a combination of the Tracking and Data Relay Satellite System

(TDRSS), which consists of two geosynchronous satellites and one ground station, and the Ground Space Flight Tracking and Data Network (GSTDN). The NASA communications network (Nascom), which may be augmented by an interface with a domestic satellite (Domsat), links the tracking stations with the ground control centers. In addition, the Deep Space Network (DSN) is used to support all interplanetary flights.

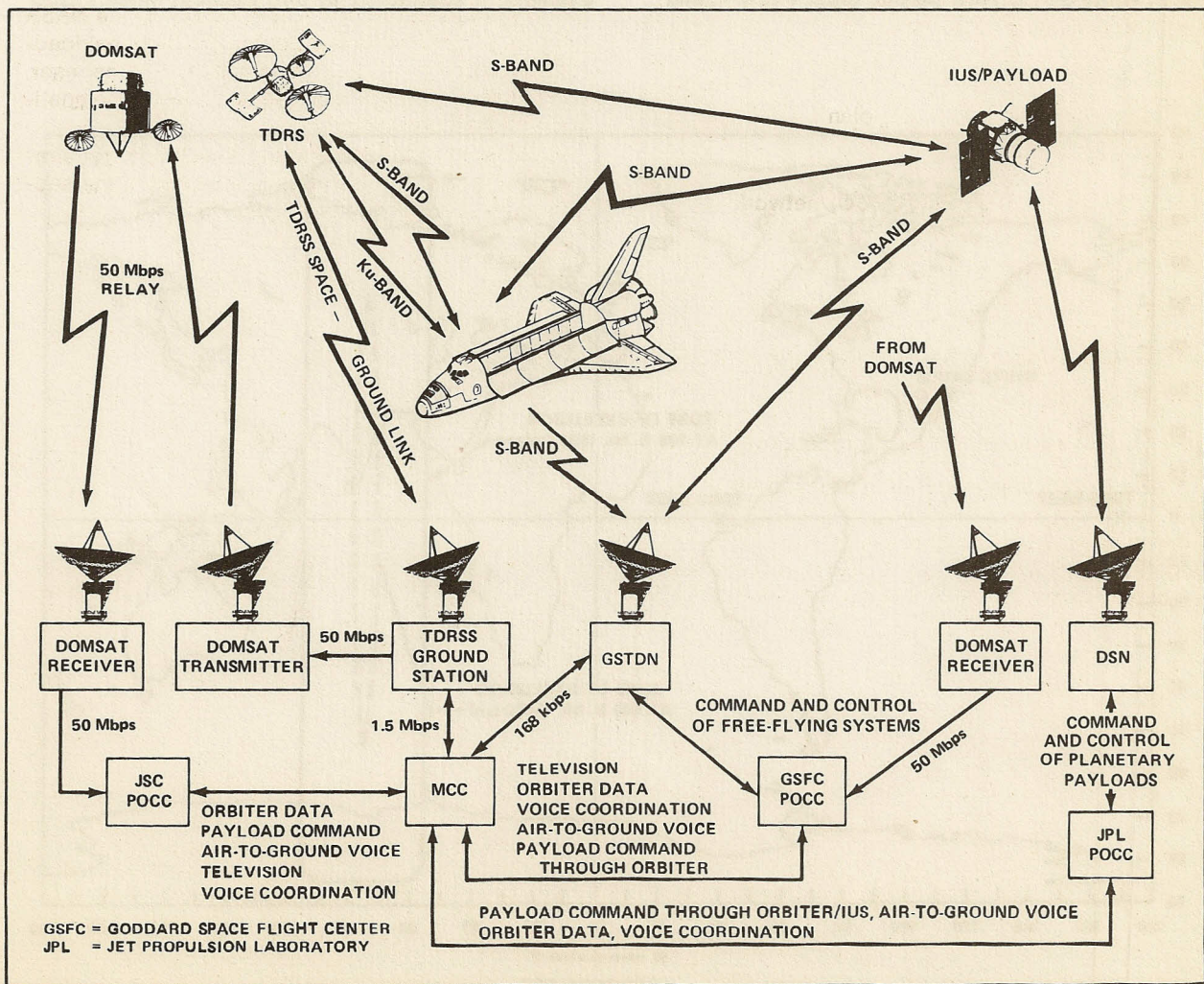

Figure 4-2.— Space Shuttle communications links.

Tracking and Data Relay Satellite System

The TDRSS provides the principal coverage for all STS flights. It is used to support Orbiter attached payloads as well as free-flying systems and propulsive upper stages in low and medium Earth orbit. The nearly continuous monitoring capability helps reduce the probability of experiment failure, reduces the need for onboard data storage, and allows inflight modification of experiments.

The system consists of two geostationary relay satellites 130° apart in longitude and a ground terminal at White Sands, New Mexico (figs. 4-3, 4-4, and

4-5). The system will include one spare satellite in orbit. The two satellites provide orbital communications coverage of low-Earth-orbiting spacecraft. Real-time geometric coverage of approximately 85 percent will be provided for most users. For orbital altitudes greater than 650 nautical miles (1200 kilometers), 100 percent geometric coverage can be provided. Geometric coverage decreases above 1620 nautical miles (3000 kilometers).

User spacecraft at low altitudes and inclinations will pass through the zone of no coverage during every orbit and therefore receive the least coverage. Those at high altitudes and high inclinations will pass through the no-coverage zone only periodically; for example, a spacecraft at 540 nautical miles (1000

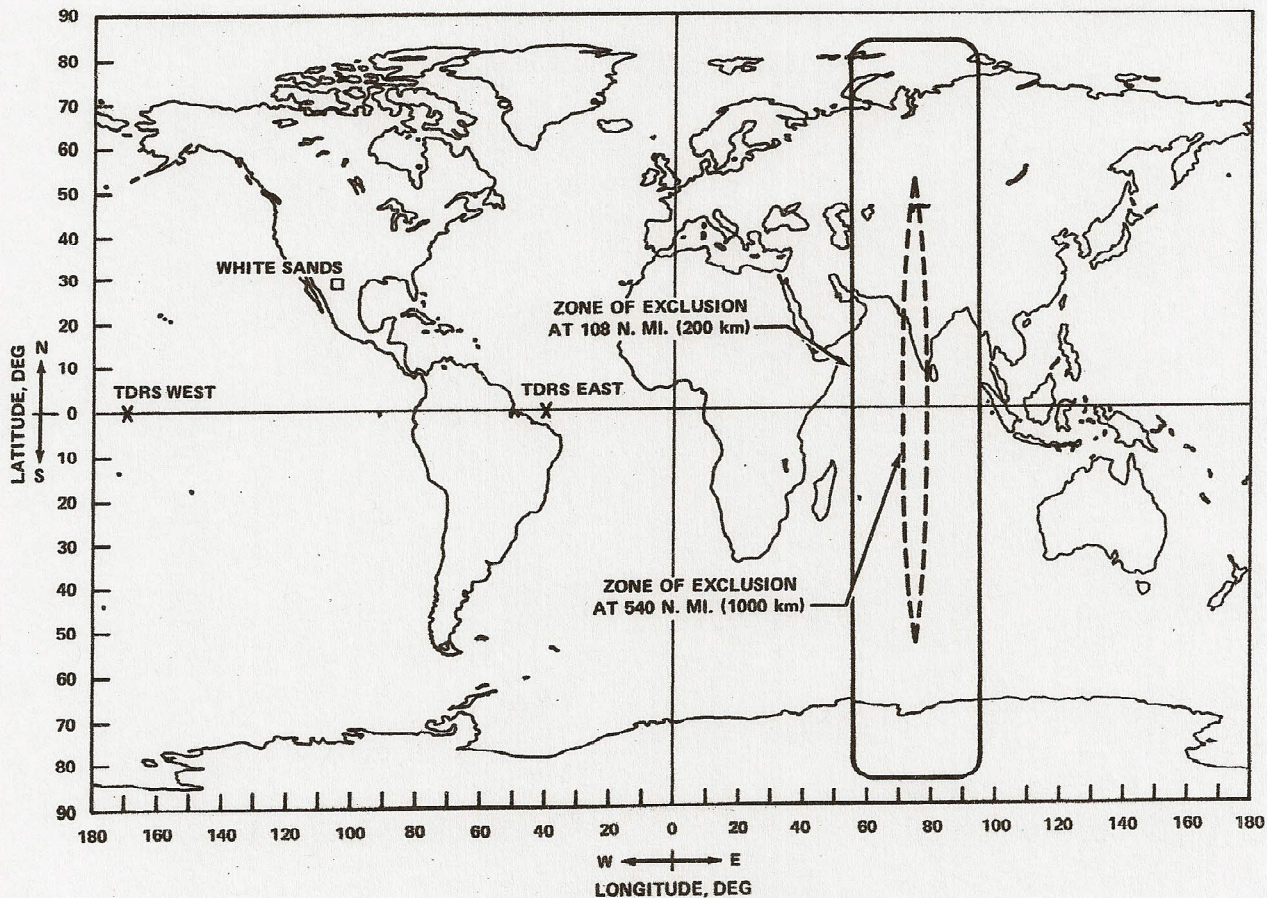

Figure 4-3.— Areas where the Orbiter is out of communication on the TDRSS network.

kilometers) will be in the zone only once per day or less. The limited-coverage area is generally between 60° and 90° east longitude (central Asia, India, and the Indian Ocean).

Communications coverage by the TDRSS may be further constrained as a result of antenna patterns during those payload operations that require specific

Orbiter attitudes. For example, an Orbiter "heads-down" position for Earth resources viewing could restrict coverage to as low as 30 percent of the time, depending on orbital inclination and Orbiter attitude position.

Details of TDRSS capabilities are provided in the TDRSS User Guide (GSFC STDN 101.2).

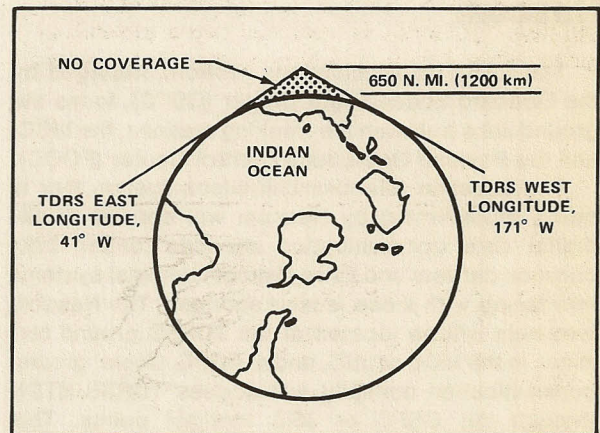

Figure 4-4.— Two-satellite TDRSS showing area of no coverage.

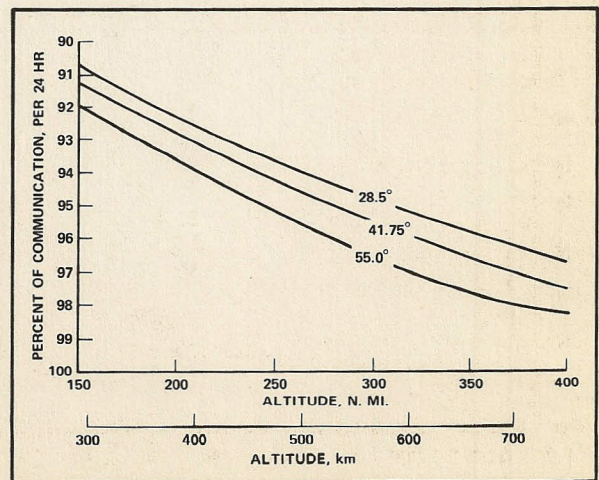

Figure 4-5.— Percent of TDRSS communication at various inclinations and altitudes.

Space Flight Tracking and Data Network

Communication with and tracking of Orbiter and other spacecraft will be accomplished by a network of worldwide ground-based tracking stations (STDN) until the TDRSS becomes operational (calendar year 1983). The ground-based tracking network will then be closed.

Nascom

The NASA communications network, managed by the Goddard Space Flight Center (GSFC), forms the ground links between the tracking stations, the MCC, and the Payload Operations Control Center (POCC).

The baseline telecommunications system that is being implemented by Nascom will consist of all-digital data communication services leased from common carriers and three Nascom terminal systems interfacing with these leased services. The Nascom terminals will be located at the TDRSS ground terminal, in the MCC at JSC, and at GSFC. Users' ground communication normally will access TDRSS/STDN through the GSFC or JSC terminal points. This baseline system will be augmented by more specialized communication facilities for delivery of high data rate science and imagery data to users.

Payload control

All commands to payloads through the Orbiter will pass through or be initiated at the MCC. As much as 2 kbps of command data (various types, formats, and bit rates) can be transmitted to payloads through the Orbiter. The intent of the Shuttle command system (onboard and ground system) is to provide maximum transparency to payload commands while retaining adequate control for crew safety. Some specialized preflight planning with the user is necessary to achieve this goal. The following command system features and operations concepts are used.

An STS/payload command plan will be developed and jointly agreed upon by JSC and the user, with particular attention given to the countdown, launch, insertion, and payload-activation sequences. To ensure Orbiter safety and to allow for interruption of normal, preplanned POCC command sequences during Orbiter contingencies, the MCC will maintain the capability to enable or disable POCC command output.

A list of payload commands that constitute a hazard to the Orbiter (while the payload is attached to or near the Orbiter) will be identified jointly by JSC and the user during preflight planning. The user may add to the list any commands considered hazardous to the payload itself. This joint command list will be entered into the MCC command software (safed).

A definite handover time for detached payload operations will be established jointly by JSC and the user before the flight. The plan will define the point after which POCC commands will cease to pass through the MCC and will be initiated and routed independently of STS commands. In establishing the proper handover time, the primary consideration is to maintain Orbiter and crew safety after the handover of command responsibility.

Telemetry and data systems

When attached payloads are flown, up to 64 kbps of data can be transmitted (interleaved with the STS operations telemetry) to the ground (table 4-1). Selected portions of these data can also be displayed onboard to the crew. The payload data and voice transmission will automatically be recorded on the operations recorder whenever the proper data format and voice channels are selected. In addition, up to 50 Mbps of data (in real time) can be transmitted to the ground through the TDRSS.

Somewhat less capability exists for detached payloads telemetry through the Orbiter (fig. 4-6). Up to 16 kbps of payload data can be transmitted to the Orbiter, displayed to the crew, and transmitted (interleaved with the STS operations telemetry) to the ground. These data (and voice, if available) will also be recorded onboard whenever the proper data format and voice channels are selected. Up to 4 Mbps (or 4.5 megahertz) can be transmitted from the payload through the Orbiter to the ground through the "bent pipe" path. However, the crew would not have access to the data.

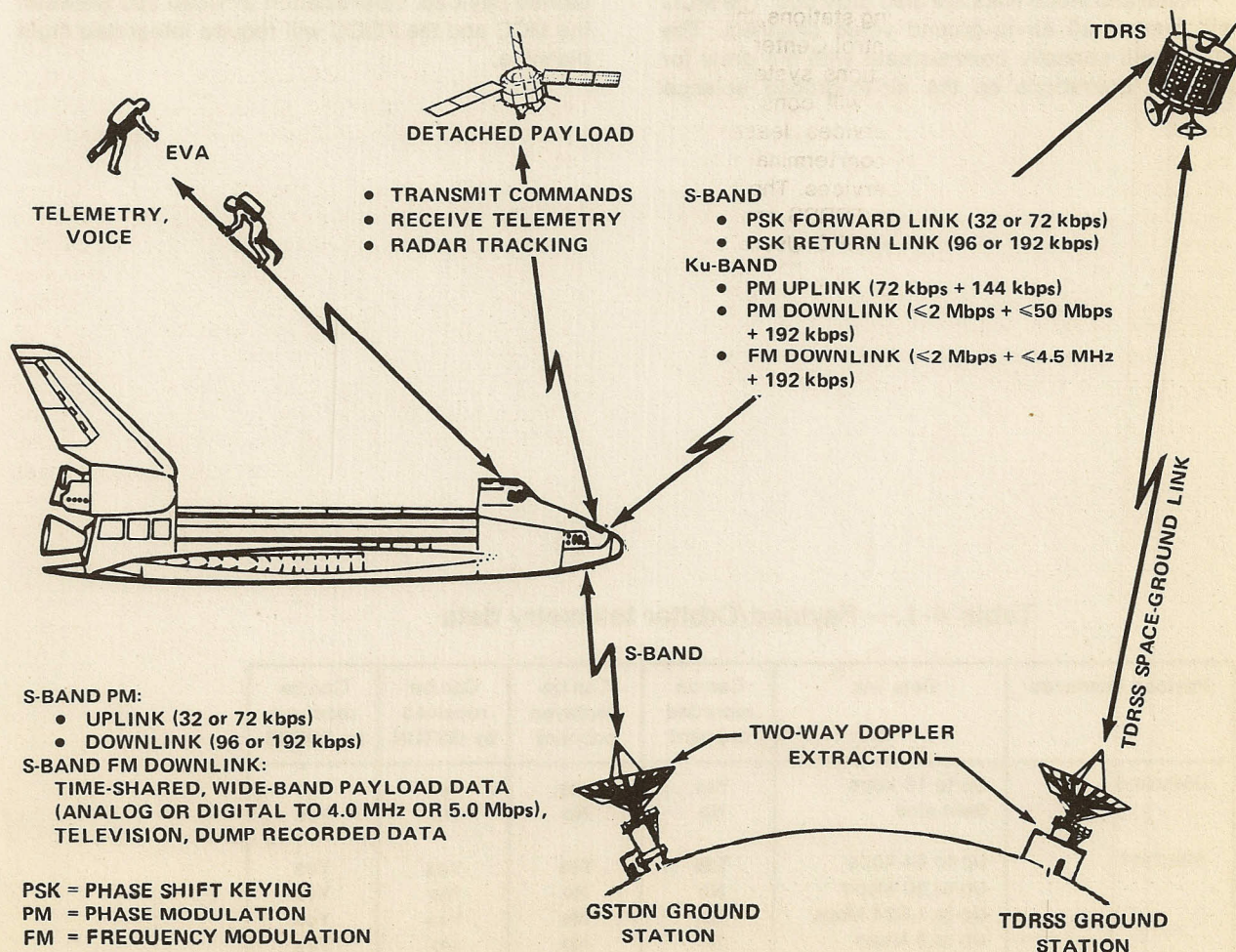

Figure 4-6.— Telemetry and data systems for detached payloads.

After crew- or ground-commanded checkout of a detached payload has been completed and after the Orbiter has maneuvered to a safe distance, the payload control function no longer involves the Orbiter. The POCC will then assume complete control of the detached free-flying payload and command/telemetry data will no longer be routed through the Orbiter or the MCC.

If a flight involves an upper stage/payload combination, the MCC will retain control through separation of the upper stage and its payload at a desired orbital position. However, a payload may have its own radiofrequency telemetry interface with a network simultaneously with the upper stage telemetry downlink.

Voice and video links are also provided. The MCC will control all air-to-ground voice channels. The POCC will normally communicate with the crew for payload operations on the air-to-ground science

operations channel (which is separate from the Orbiter operations channel). However, if the command/telemetry interface is low bit rate to and from the Orbiter, the POCC will share the same channel with the MCC. The MCC will continuously monitor usage of the air-to-ground science operations channel and will enable or inhibit POCC voice capability as required for crew safety and in-flight operations.

The crew controls voice recording, but the MCC, with crew coordination, controls recorder dumps (playbacks to the radiofrequency system for downlink of recorded information).

The source of video can be the cockpit television camera, one of the four cameras associated with the cargo bay and manipulators, or a camera on an attached payload. Coordination of video use between the MCC and the POCC will require integrated flight planning.

Table 4-1.— Payload/Orbiter telemetry data

Payload interfaces	Data link	Can be recorded onboard	Can be displayed onboard	Can be received by GSTDN	Can be received by TDRSS
Detached	Up to 16 kbps	Yes	Yes	Yes	Yes
	Bent pipe	No	No	No	Yes
Attached	Up to 64 kbps	Yes	Yes	Yes	Yes
	Up to 50 Mbps	No	No	No	Yes
	Up to 1.024 Mbps	No	No	Yes	Yes
	Up to 5 Mbps	No	No	No	Yes
	4.2-MHz television	No	Yes	Yes	Yes

MISSION CONTROL CENTER

During all on-orbit periods when a payload has an operational interface with the Space Transportation System, flight operations support will be provided jointly by the MCC and the POCC responsible for that payload. The MCC will provide total support for other phases of the Orbiter flight—prelaunch, ascent, re-entry, and landing.

For all flights, the MCC provides systems monitoring and contingency support for all STS elements, provides two-way communications interface with the crew and onboard systems, performs flight data collection to a central site, and provides a preflight and in-flight operational interface with the POCC to coordinate flight operations.

Specific types of payloads require some variations in the interface support provided by the MCC. The MCC operation has sufficient flexibility to accommodate all types of missions with varying degrees of user participation and STS services to payloads. The operations concepts are intended to provide economical and convenient services in response to user needs.

The three basic flight types involve attached payloads, deployment and retrieval in Earth orbit, and use of upper stages to deliver payloads.

For flights involving attached payloads, the MCC provides these standard items: support systems monitoring, contingency support, and systems support for unattended operations; Spacelab software support for standard Spacelab services; interface systems support; and other items related to combined POCC and MCC tasks. The MCC also provides a ground team to develop preflight documentation required for a given flight, including the STS flight rules and constraints, troubleshooting plans and procedures, and command plans. The ground support role is flexible and able to operate with standardized Spacelab configurations and documentation sets.

Deployment and retrieval missions fall into two broad categories of MCC support: those requiring little or no checkout or special training of flightcrews and operations support personnel and those that involve significant crew activities and systems interfaces between the Orbiter and the payload. For the limited-interface category, MCC support will follow a standardized plan that requires consideration only of trajectory and deployment end conditions. Variations in ground systems may relate only to command and telemetry format modifications and trajectory monitoring.

The MCC interface will be more extensive for those flights that require significant crew and systems interfaces. Real-time telemetry and voice and command system capabilities will be provided through STS operations interfaces. Payload systems expertise will be provided by the user. Payload telemetry processing at the MCC will include only those payload data received in the operational data stream that are required to accomplish STS interface responsibilities.

For payloads involving the use of standard propulsive upper stages (requiring trajectory placement that cannot be achieved by the Orbiter), the MCC will be responsible for the systems monitoring, contingency support, and operational control of the upper stage. Telemetry data from the upper stage will be processed at the MCC to support flight control, both while the upper stage is in the cargo bay and while it is operating deployed from the Orbiter. Payload data transmitted through the Orbiter or independently of the STS communication systems will also be made available at the MCC if those data are required to support flight operations.

The STS operations organization within the MCC consists of three major elements or functions: a planning operations management team (POMT), multipurpose support groups, and small flight control teams (fig. 4-7).

The POMT serves primarily to perform a preflight

(approximately 2 years to 16 weeks before launch) function, with management responsibility for the detailed development, planning, scheduling, and status of all STS flights. The POMT will provide assistance to the user in preparing requirements documentation for facilities, software, command, telemetry, flight requirements, and POCC interfaces. Documentation of these requirements will reside in the PIP and their annexes.

The multipurpose support function includes the bulk of STS flight planning, procedures development, and systems expertise and manpower. The multipurpose support teams provide direct support for preflight planning and training activities and, during the flight, provide systems and trajectory status support to the flight control room on a routine and periodic basis.

The flight control team is the only flight-dedicated element in the operations concept; members of this team are on duty 24 hours a day for the duration of each STS flight. They provide direct real-time flight support to the crew through flight monitoring and assistance during launch and entry, and by following the flight activities during the orbital phase. The real-time planning and execution of payload operations activities, which do not affect or change the integrated STS/payload operations, will be primarily the responsibility of the POCC.

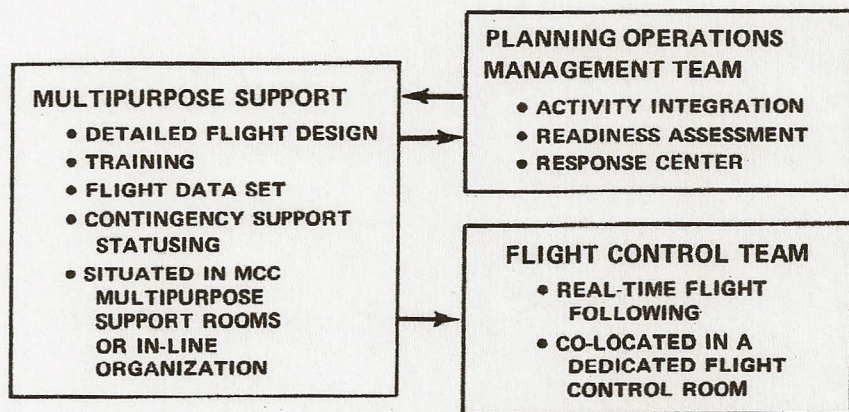

Figure 4-7.— The three major elements of the STS operations.

PAYLOAD OPERATIONS CONTROL CENTER

Operating in conjunction with the JSC Mission Control Center are Payload Operations Control Centers from which the STS users or experimenters can monitor and control their payloads (fig. 4-8).

The relationship between the MCC and each POCC is essentially the same. Each POCC has the computation and display capability necessary to provide data for operational control of payloads as well as the capabilities for payload communications and command.

Normally, only one POCC will be involved with a single flight. Attached payloads, including all Spacelab manned modules and/or pallets, are controlled from the POCC at JSC. Free-flying systems that are deployed, retrieved, or serviced in Earth orbit by the Orbiter are monitored by a POCC at the Goddard Space Flight Center. Payloads with distant destinations, such as those exploring other planets, are controlled from the POCC at the Jet Propulsion Laboratory (JPL).

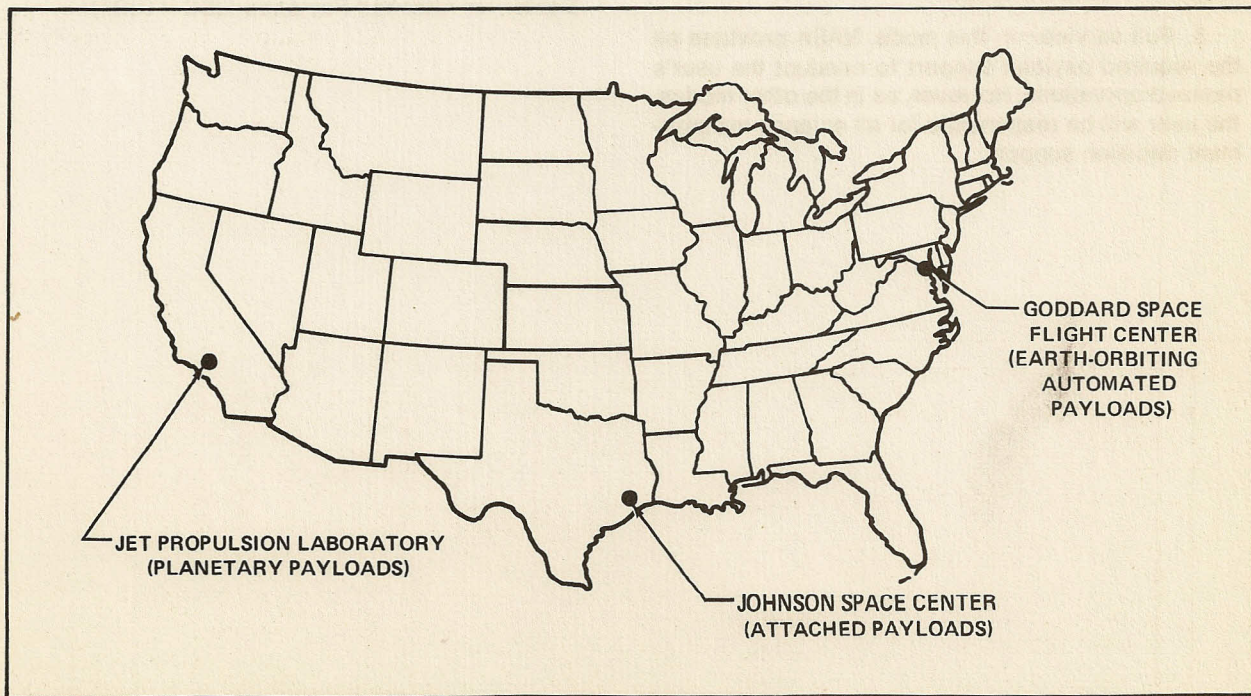

Figure 4-8.— Location of Payload Operations Control Centers.

Attached payloads

Flight operations activities for support of attached payloads are conducted from the POCC at JSC. This POCC provides the facilities and accommodations necessary to monitor and control the payloads operations.

The user can select the level of support needed in the POCC for payload support. The three basic modes are as follows.

1. **Host**—In this mode, the POCC provides host facilities with a standard complement of capability for data monitoring, payload commanding, and voice communications with the crew and the MCC. The user provides all the payload operations personnel necessary to support real-time crew activity planning, crew procedures changes, command and control planning systems monitoring, science processing, and analysis. JSC will man one console position in the POCC to provide command interface management support to the payload experiments.

2. **Limited**—In this mode, the user provides part of the payload support and NASA provides payload support in selected areas.

3. **Full service**—In this mode, NASA provides all the required payload support to conduct the user's payload operations. However, as in the other modes, the user will be responsible for all science management decision support.

Generally, the same data that are available to the STS controllers within the MCC are also available to the user in the POCC. The POCC also provides similar capability to the MCC for command uplink and voice communications both with the onboard crew and with flight controllers in the MCC. Table 4-2 provides a summary of the standard capabilities in the JSC POCC for data monitoring, command and control, accommodations, and services.

Interfaces between the POCC and the MCC are simplified somewhat by the fact that both are located in the same building (building 30 Mission Control Center complex) at JSC. Payload operations for attached payloads require close coordination between the POCC and the MCC throughout the duration of a flight because no handoff is made, as it is to the other two POCC's when their spacecraft get out of range of the Orbiter.

The responsibility for managing and staffing the JSC POCC lies with the user; thus, the organizational structure is flexible and may vary somewhat from flight to flight. However, the user is expected to designate an individual within the POCC who has overall responsibility for all payload operations decisions. See the document Payload Operations Control Center for Attached Payloads (JSC-11804).

Table 4-2.— JSC POCC capabilities

Facility	<ul style="list-style-type: none"> • Terminals, desks, chairs, tables, recorders, telephones, headsets for voice monitoring, conference areas
Voice communications	<ul style="list-style-type: none"> • Voice loops (both internal and external to JSC) for coordinating STS/payload flight planning activities • Two-way voice communications with crew during flight • Voice tapes of crew conversations
Command data (uplink)	<ul style="list-style-type: none"> • Commands can be initiated from an assigned console position in the POCC • Command histories can be retrieved from real-time processors and displayed on the console • Command histories may be obtained from off-line processors (printouts or tapes)
Telemetry data (downlink)	<ul style="list-style-type: none"> • Real-time monitoring of the STS systems data (same capability as STS controllers) • Real-time processing and display of payload command and control data • Limited real-time processing and display of payload operations data contained in independent science downlinks • Limited near-real-time processing and display of payload operations data contained in independent science downlinks
Communications terminals	<ul style="list-style-type: none"> • Real-time or playback data can be routed over user circuits to a user remote facility • Optional data processing is available to package data to user specifications for transmission to a user facility
Data processing	<ul style="list-style-type: none"> • Standard unit conversion, limit sensing, and simple arithmetic computations • Analysis program support (the amount of support will be negotiated on a case-by-case basis)
Trajectory	<ul style="list-style-type: none"> • All ongoing trajectory and Orbiter attitude information will be made available to users as required (same capability as STS controllers) • Orbit phase processing of trajectory will be performed as negotiated to support payload operations
Output devices	<ul style="list-style-type: none"> • Digital television equipment displays • Strip-chart recorders • Tabular reports • Raw data tapes
Video downlink	<ul style="list-style-type: none"> • Can monitor in real time all STS-compatible video downlink

Free-flying automated payloads

Goddard Space Flight Center is equipped to conduct operations of NASA Earth-orbiting free-flying spacecraft. Eight to ten individual GSFC POCC's exist, each of which has the capability to support flight operations of several spacecraft. Normally, an individual dedicated POCC will support a series of spacecraft or spacecraft in similar scientific disciplines. A Multisatellite Operations Control Center, which provides support for those spacecraft that do not require a dedicated POCC, can support 5 to 10 spacecraft, depending on the extent of operational requirements.

The GSFC payload operations are functionally organized into three main areas: the project operations control center, which is the focal point for payload operations and control; the support computing functions, which include computations of orbit, attitude, flight maneuvers, and spacecraft control; and the sensory data processing, which provides preprocessed time-ordered data and processed image data to experimenters and organizational users. These functions and their relationships are illustrated in figure 4-9 and described in the document Payload Operations Control Center for Earth-Orbiting Automated Payloads (GSFC).

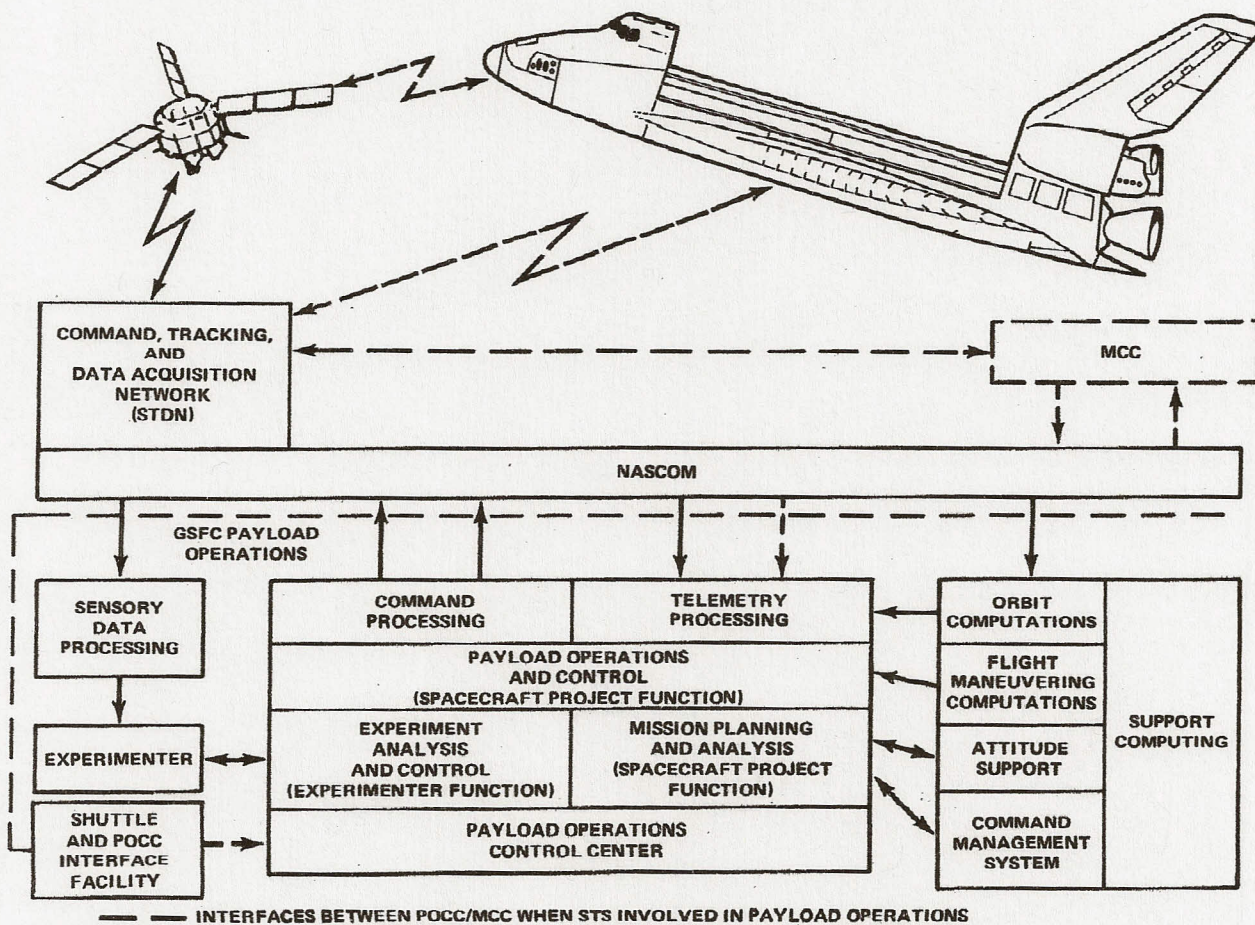

Figure 4-9.— GSFC payload operations.

A non-real-time computing capability exists for mission analyses, design of payload flightpath, and in-orbit flight data analysis and navigation computations. The capability exists to simulate spacecraft characteristics, operational constraints, and environmental parameters and to generate data for checkout of the end-to-end data system spacecraft responses to command activities. The simulation capability is normally mission-unique.

The standard POCC capabilities are quite similar to those described previously for the JSC POCC. The size and computational support will vary, depending on individual mission requirements.

The GSFC POCC normally provides the control facilities, computational capability, and software necessary to interface with the STDN, to process the free-flying spacecraft telemetry data, to generate the necessary data outputs and displays to support the spacecraft evaluation and operations, and to generate the necessary commands for spacecraft operation. The required operations personnel are also provided by GSFC.

The user normally provides the spacecraft operations team, which works from a mission operations room. The individual experimenters and principal in-

vestigators either work within or have interfaces to the POCC. They are responsible for operation and evaluation of their own experiments. If required, data can be transmitted to an experimenter's home facilities, at the experimenter's expense. For detailed information about remote POCC interface, refer to the document Remote POCC Capabilities (JSC-14433, Vol. II).

Each POCC at GSFC will provide standard interfaces to the STS for times when operations are conducted with the spacecraft attached to the Orbiter or in its sphere of influence. Spacecraft command and telemetry interfaces are the exclusive responsibility of the POCC.

The Shuttle POCC Interface Facility (SPIF) is the central point of contact for the GSFC POCC/STS interface. Support provided by the SPIF minimizes the differences between POCC activities required to support an Orbiter-supported spacecraft and a free-flying spacecraft. The SPIF, as a standard service, processes and distributes STS-unique data (Orbiter ancillary, JSC status, Orbiter attitude and ephemeris) to the POCC. Support from a POCC at GSFC is arranged through the Office of Space Tracking and Data Systems at NASA Headquarters.

Planetary payloads

The POCC at the Jet Propulsion Laboratory (also called the Mission Control and Computing Center) is equipped to support planetary or lunar mission operations as well as some Earth-satellite operations managed by JPL. More than one mission can be supported simultaneously. The JPL POCC includes two buildings, the Space Flight Operations Facility and part of the System Development Laboratory. The amount of actual area needed changes with the mission requirements.

An auxiliary powerhouse, computers, software, terminal and display equipment, communication equipment, operating personnel, and other miscellaneous items are part of the JPL POCC and are described in the document Payload Operations Control Center for Planetary Payloads (JPL).

The functional systems include those for imaging, telemetry, operations and control, simulation, command, tracking, and data recording.

Figure 4-10 shows the top-level data processing hardware configuration. In this illustration, two missions are being supported simultaneously. Mission 1 is receiving its data from the Deep Space Network, while mission 2 (which could be either in a launch

configuration test or a launch/on-orbit phase) is receiving data from the STS.

The two basic categories of computers and associated equipment are for real-time and non-real-time processing. For real-time processing, a decentralized approach, using dedicated computer configurations, is followed.

When the mission requires it, image processing to generate pictures and the processing of image data to obtain optical navigation parameters are performed in dedicated computer configurations. These configurations may or may not be connected to the real-time data communication network. Neither function is required in the STS/POCC interface.

The non-real-time computing is shared by all missions in a large, centralized computer configuration, where all flight data analysis and navigation computation, mission sequencing necessary for mission control, and generation and validation of the final data records are performed. Some of the data record file preparation is performed on minicomputers.

Simulations of the spacecraft and of other external data interfaces of the end-to-end data system are obtained through a computer-based simulation system dedicated to a mission. Backup configurations are also provided.

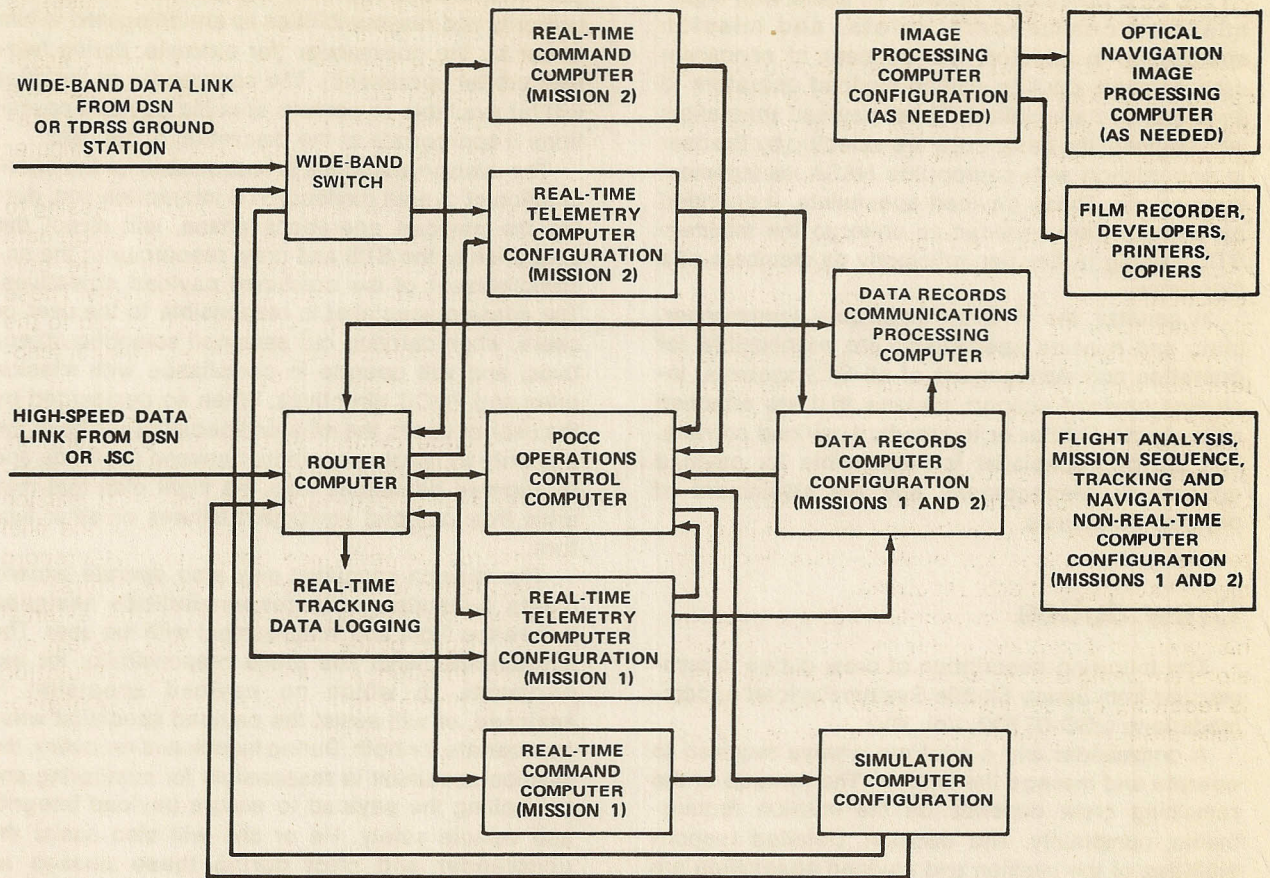

Figure 4-10.— Configuration of computers for handling multiple missions.

TRAINING AND SIMULATIONS

The STS operations provide all users with flight-qualified commanders, pilots, and mission specialists. In addition, the concept of noncareer crewmembers permits visiting payload operators to fly as payload specialists. These payload specialists who augment the basic crew are selected by the user in accordance with appropriate NASA management instructions. These payload specialists, if provided by the user, are required to undergo the minimum STS training to function efficiently as members of a flightcrew.

In general, the STS crewmembers (commander, pilot, and mission specialists) are responsible for operation and management of all STS systems, including payload support systems that are attached either to the Orbiter or to standard payload carriers. The payload specialist is responsible for payload operations, management, and the attainment of payload objectives.

Crew duties

The following description of crew duties is summarized from Space Shuttle System Payload Accommodations (JSC-07700, Vol. XIV).

A commander and a pilot are always required to operate and manage the Orbiter. The makeup of the remaining crew depends on the mission requirements, complexity, and duration. Detailed responsibilities of the mission and payload specialists are tailored to meet the requirements of each individual flight.

The commander has the ultimate responsibility for the safety of embarked personnel and has authority throughout the flight to deviate from the flight plan, procedures, and personnel assignments as necessary to preserve crew safety or vehicle integrity. The commander is also responsible for the overall execution of the flight plan in compliance with NASA policy, mission rules, and MCC directives.

During the payload operations phase of the flight, the commander will, within the described limitations connected with crew safety and vehicle integrity, direct the allocation of the STS resources to the accomplishment of the combined payload objectives, including consumables allocation, systems operation, and flight plan modifications.

The pilot is second in command of the flight. The pilot assists the commander as required in the con-

duct of all phases of Orbiter flight. He or she has such authority and responsibilities as are delegated to him or her by the commander (for example, during two-shift orbital operations). The commander or the pilot will be available to perform specific payload operations if appropriate at the discretion of the user.

The mission specialist is responsible for the coordination of overall payload/STS interaction and, during the payload operations phase, will direct the allocation of the STS and crew resources to the accomplishment of the combined payload objectives. The mission specialist is responsible to the user or users, when carrying out assigned scientific objectives, and will operate in compliance with mission rules and POCC directives. When so designated by the user or users, the mission specialist will have the authority to resolve conflicts between payloads and to approve deviations from the flight plan that may arise from payload equipment failures or other factors.

The mission specialist may also operate experiments consistent with responsibilities assigned before the flight and in agreement with the user. The mission specialist has prime responsibility for experiments to which no payload specialist is assigned, or will assist the payload specialist when appropriate, or both. During launch and recovery, the mission specialist is responsible for monitoring and controlling the payload to ensure payload integrity and vehicle safety. He or she will also assist the commander and pilot during these phases as required.

The payload specialist is responsible for the operation and management of the experiments or other payload elements that are assigned to him or her and for the achievement of their objectives. The payload specialist is responsive to the authority of the mission specialist and operates in compliance with mission rules and POCC directives. He or she will be an expert in experiment design and operation, and onboard decisions about detailed experiment operations will be made by the payload specialist. When desired by users, a payload specialist may be designated to resolve conflicts between those users' payloads and to approve deviations from the flight plan that may arise from payload equipment failures or other factors related to these payloads.

The payload specialist may be cross-trained as necessary to assist the mission specialist or other payload specialists in experiment operation but may

not be required to manage experiments outside his or her area of expertise. In some instances, the payload specialist may be responsible for all experiments on-board. The specialist may operate those Orbiter and Spacelab payload support systems that are required for efficient experiment operation, such as an instrument pointing system, command and data-management system, and scientific airlocks. The payload specialist will be responsible for knowing how to operate certain Orbiter systems, such as hatches and food and hygiene systems, and for proficiency in those normal and emergency procedures that are required for safe and efficient crew operations.

The responsibility for the on-orbit management of Orbiter systems and attached payload support systems, as well as for extravehicular activity and payload manipulation with the remote manipulator system, rests with the basic crew because extensive training is required for safe and efficient operation of these systems. Assignment of these functions within the basic crew will vary to meet the requirements of each flight. In general, the commander and pilot will manage Orbiter systems and standard payload support systems, such as Spacelab and IUS systems; the mission specialist and/or payload specialists will manage payload support systems that are mission dependent and have an extensive interface with the payload, such as instrument pointing systems.

STS crew training

The STS crewmembers are available on orbit for user-defined functions approximately 8-1/2 hours per crewmember per shift. In certain cases, it will be to the user's advantage to utilize an STS crewmember for the management or operation of the payload (experiment). Use of the mission specialist as the prime onboard payload manager/operator and use of the commander or pilot as payload operator will require special training. The extent of crew participation in payload functions is limited by the amount of preflight training time available.

Special payload or experiment training is highly dependent on how a specific user desires to involve the STS crewmember with the payload or experiment; therefore, it is best provided by the user instead of the STS operations. The explicit involvement will be defined during the payload-to-STS integration process. However, before this integra-

tion, the user should consider the choice of training facilities.

Training facilities may be in the form of mockups, functional trainers, mathematical models compatible with various computer complexes, or complete payload (experiment) simulators. They may be designed to emphasize the payload's philosophy, operations, malfunctions, objectives, or requirements. They can be located either at JSC or at a site chosen by the user.

Several training facilities at JSC are capable of providing an interface to payloads or experiments and therefore can be used to provide flightcrew training in payload operations. Classrooms equipped for audiovisual presentations are available to the user at JSC.

The Orbiter one-g trainer is a full-scale representation of the flight deck, middeck, and midbody. Payload interface attachment points are provided in the cargo bay. It will be used for flightcrew training in habitability, extravehicular activity, ingress, egress, television, waste management, stowage, and routine housekeeping and maintenance.

The Orbiter neutral buoyancy trainer, designed to be used in a water immersion facility, is a full-scale representation of the crew cabin middeck, airlock, and cargo bay doors. It also has attachment points in the cargo bay. This facility provides a simulated zero-g environment for training in EVA procedures.

The Shuttle mission simulator (SMS) (fig. 4-11) provides full-fidelity forward and aft crew stations. The SMS is computer controlled with systems mathematical models, consistent with the flight dynamics, driving the crew station displays. It will be used to provide training on combined systems and flight team operations. It includes the capability to simulate payload support systems with mathematical models, RMS dynamic operations using computer-generated imagery, and Spacelab support systems by interfacing with the Spacelab simulator. The SMS can be interfaced with the MCC for conducting crew/ground integrated simulations.

The RMS task trainer consists of an aft crew station mockup, a cargo bay mockup, and a mechanically operated arm. It will provide an environment for training on payload grappling (in the cargo bay), berthing, visual operations, cargo bay camera operations, and manipulator software operations. The user will provide helium-inflatable models to simulate the payload geometrically.

The Spacelab simulator (SLS) consists of a core and experiment segment interior with computer modeling of the Spacelab systems. It will be used for crew and ground team training on flight-independent

systems and for some limited flight-dependent training. The SLS will also be used as a one-g trainer for crew accommodations, habitability, stowage, and safety methods.

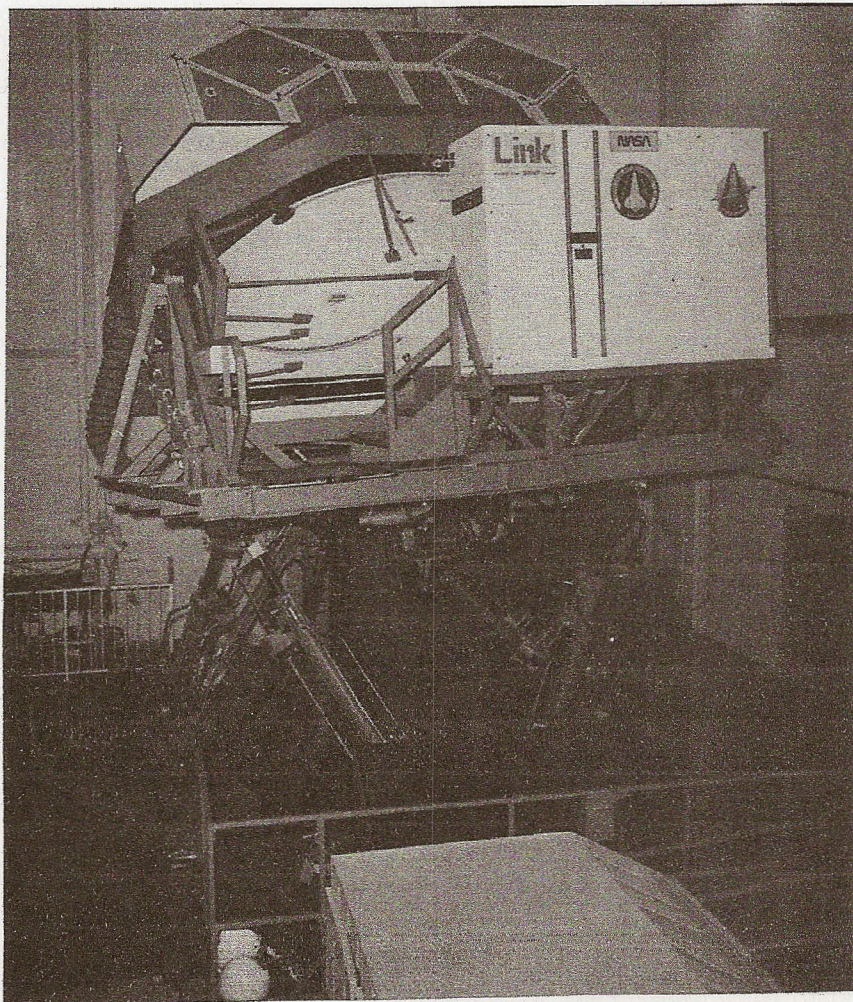

Figure 4-11.— Motion base crew station of the Shuttle mission simulator.

Payload specialist training

The training requirement for a payload specialist scheduled for a flight with Spacelab pallets requires 189 hours; for a flight with a Spacelab module, 203 hours of training are required. These numbers are each reduced by 21 hours if no instrument pointing system training is required.

Tables 4-3 to 4-7 and figure 4-12 illustrate the typical training schedule and types of training for a payload specialist. The 12-month schedule is typical; however, for some payloads, the user may want the candidate to be screened longer before the flight. In the tables, no attempt has been made to break down the number of hours for each task; the totals for each trainer are representative and intended to provide only a general idea of the training required. An X indicates that some time is required in the facility and a C indicates coordinated training with at least one STS crewmember present.

The remaining time can be allocated to STS/payload flight plan integration and reviews, flight/mission rules development and reviews, flight techniques meetings, and flight requirements implementation reviews.

Flight-independent training for the payload specialist involves those crew tasks necessary for

any crewman to function effectively during flight. This training consists primarily of workbook, classroom, Orbiter-2g, and Spacelab/single-system-trainer (SST) lessons.

Flight-dependent training can be divided into two types: payload discipline training and training necessary to support STS/payload integrated operations. The second is characterized by integrated simulations involving the entire flightcrew and ground-based flight operations support teams. These simulations—in one or more of the JSC training facilities—will involve the appropriate POCC as necessary and will practice accomplishment of various payload objectives to ensure a certain measure of mission success.

Payload discipline training consists of the individual experiment training and includes use of user research facilities, experiment prototype or development hardware, and possibly experiment flight hardware. There may be certain limitations to using flight and development hardware for training exercises. However, in general, the amount and type of payload training for the crew is the responsibility of the user, who should provide whatever training is considered necessary. This training may start as early as 2 or more years before a flight.

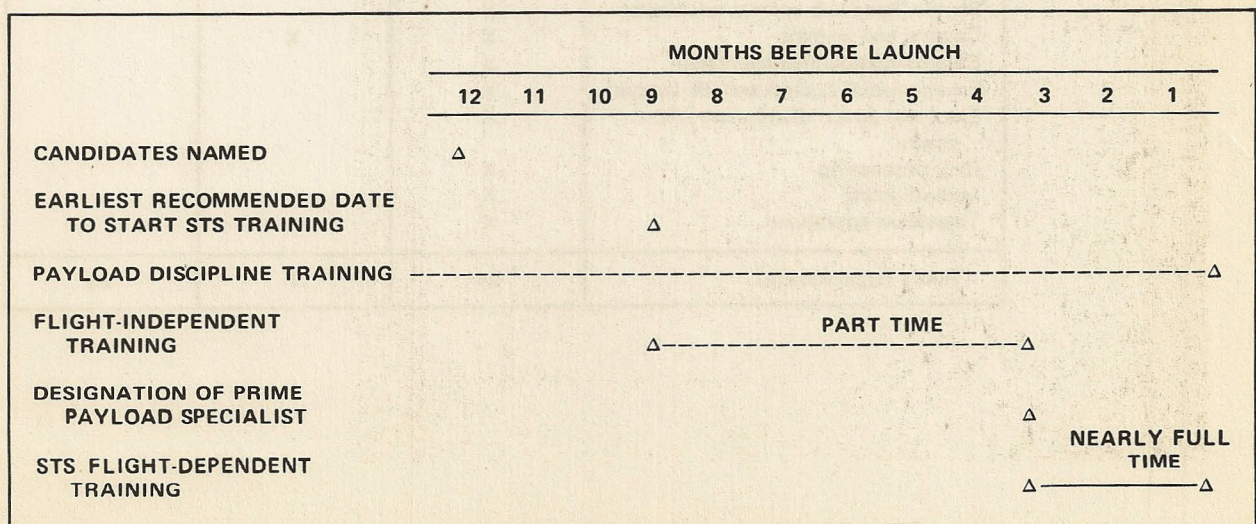

Figure 4-12.— Typical training schedule for a payload specialist.

Table 4-3.— Crew systems training

Type of training	Facility			Total
	Classroom or workbook	Orbiter one-g trainer	Water Immersion Facility	
Habitability	X	X		
Closed-circuit television	X			
Photography	X			
Ingress/egress		C		
Medical	X			
Survival	X	C	C	
Emergency (on orbit)	X	X		
Hours (approximate)	30	30	3	63

Table 4-4.— Orbiter systems training

Type of training	Facility		Total
	Classroom or workbook	SST	
Shuttle/Spacelab vehicle orientation	X		
Caution and warning	X	X	
Communication/instrumentation	X		
Environmental control and life support	X		
Electrical power distribution and control	X		
Data processing	X		
Audio/lighting	X		
Television operations	X		
Hours (approximate)	24	1	25

Table 4-5.— Spacelab systems training

Type of training	Facility						Total	
	Classroom or workbook		SST		SLS			
	Pallet	Module	Pallet	Module	Pallet	Module	Pallet	Module
Command and data management	X	X	X	X				
Audio		X		X		X		
Environmental control	X	X						
Electrical power distribution	X	X						
Instrument pointing (if required)	X	X	X	X				
Scientific airlock/viewport		X				X		
Systems overview	X	X						
Caution and warning	X	X	X	X				
Hours ^a (approximate)	21-30	28-37	7-19	8-20	0	6	28-49	42-63

^aHigh number in range of hours includes instrument pointing system; low number does not.

Table 4-6.— Spacelab phase training

Type of training	Facility	Total
	SMS/SLS	
Spacelab activation/ on orbit/deactivation	C	
Hours (approximate)	8	8

Table 4-7.— Integrated mission simulations

Type of training	Facility	Total
	SMS	
Ascent	C	
Spacelab activation/ on orbit/deactivation	C	
Descent	C	
Hours (approximate)	44	44

Ground team

The flight operations support team can be divided into an STS team and a POCC team. These teams and the flightcrew must function together to accomplish the flight objectives. Each team has unique responsibilities that will require coordination with each other and with the flightcrew. Initial training of each of these teams is conducted independently and culmi-

nates in the joint crew/POCC/STS ground team integrated simulations. The STS support team will receive their training through the formal JSC training process. The POCC support team will receive training on the STS hardware provided in the JSC POCC and will participate in integrated simulations as required. Further POCC support team training requirements are included in the users' guide for each POCC.

APPENDIX A

References

References

The user guides that are listed in this appendix represent a condensation of many documents and are designed to assist the user and to supplement the major parts of the Space Transportation System User Handbook. The documents are listed below ac-

ording to the parts of the handbook to which they refer.

Initial contacts for planning and questions of a general nature should be directed to the Space Transportation System (STS) Utilization Office, Mail

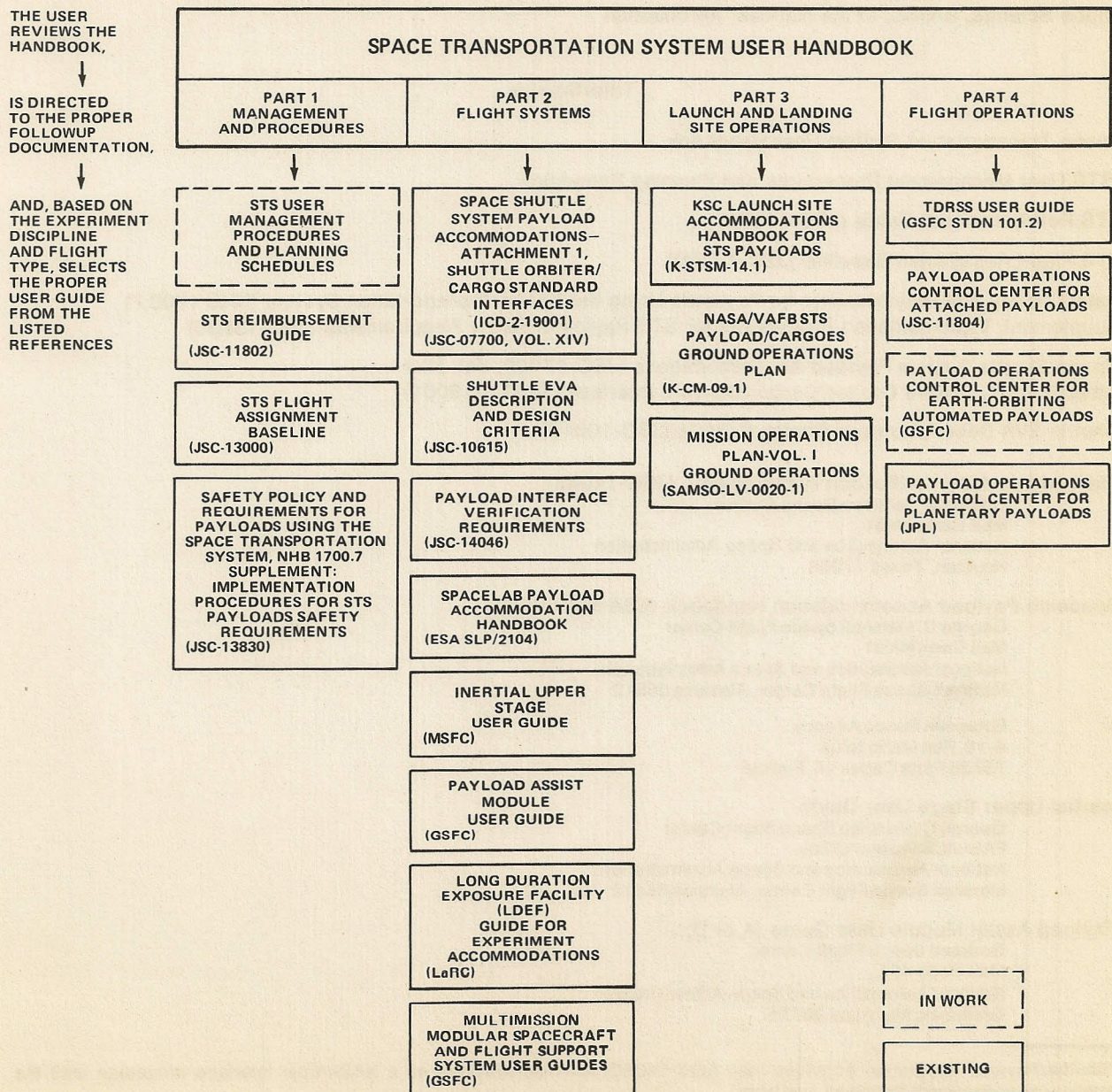

Code OT, National Aeronautics and Space Administration, Washington, D.C. 20546; telephone (202) 755-2344; Federal telecommunications system 755-2344. Announcements of space flight opportunities may be requested from the following offices (depending on discipline): Office of Space and Terrestrial Applications, E/OSTA; Office of Aeronautics and Space Technology, R/OAST; and Office of Space Science, S/OSS, at the National Aeronautics

and Space Administration, Washington, D.C. 20546.

Users requiring any of the publications listed below should make their requests on company or government letterhead to the organization listed as the source of each document. Preliminary documents are available as substitutes for the user guides that have not been published.

Title/Source

Space Transportation System User Handbook

*STS User Management Procedures and Planning Schedules

STS Reimbursement Guide (JSC-11802)

STS Flight Assignment Baseline (JSC-13000)

Safety Policy and Requirements for Payloads Using the Space Transportation System (NHB 1700.7)
Supplement: Implementation Procedures for STS Payloads Safety Requirements (JSC-13830)

Space Shuttle System Payload Accommodations (JSC-07700, Vol. XIV)
Attachment 1, Shuttle Orbiter/Cargo Standard Interfaces (ICD 2-19001)

Shuttle EVA Description and Design Criteria (JSC-10615)

Payload Interface Verification Requirements (JSC-14046)

Lyndon B. Johnson Space Center
Mail Code JM61
National Aeronautics and Space Administration
Houston, Texas 77058

Spacelab Payload Accommodation Handbook (ESA SLP/2104)

George C. Marshall Space Flight Center
Mail Code NA 01
National Aeronautics and Space Administration
Marshall Space Flight Center, Alabama 35812

or
European Space Agency
8-10, Rue Marlo Niki
75738 Paris Cedex 15, France

Inertial Upper Stage User Guide

George C. Marshall Space Flight Center
FA51 /IUS Project Office
National Aeronautics and Space Administration
Marshall Space Flight Center, Alabama 35812

Payload Assist Module User Guide (A or D)

Goddard Space Flight Center
Mail Code 495
National Aeronautics and Space Administration
Greenbelt, Maryland 20771

*Shuttle/Payload Integration Activities Plan (JSC-14363) shall be provided as a NASA/user interface procedure until the agency-level document becomes available.

Long Duration Exposure Facility (LDEF) Guide for Experiment Accommodations

Langley Research Center
Mail Stop 258
National Aeronautics and Space Administration
Hampton, Virginia 23665

Multimission Modular Spacecraft and Flight Support System User Guides

Goddard Space Flight Center
Mail Code 408
National Aeronautics and Space Administration
Greenbelt, Maryland 20771

KSC Launch Site Accommodations Handbook for STS Payloads (K-STSM-14.1)

NASA/VAFB STS Payloads/Cargoes Ground Operations Plan (K-CM-09.1)

John F. Kennedy Space Center
Mail Code CP-DPO
National Aeronautics and Space Administration
Kennedy Space Center, Florida 32899

Mission Operations Plan, Volume I, Ground Operations (SAMSO-LV-0020-1)

Space and Missile Systems Organization
U.S. Air Force Systems Command
Los Angeles Air Force Station
Attn: Code YVO
Box 92960, Worldway Postal Center
Los Angeles, California 90009

TDRSS User Guide (GSFC STDN 101.2)

Goddard Space Flight Center
Mail Code 863.3
National Aeronautics and Space Administration
Greenbelt, Maryland 20771

Payload Operations Control Center for Attached Payloads (JSC-11804)

Lyndon B. Johnson Space Center
Mail Code JM61
National Aeronautics and Space Administration
Houston, Texas 77058

Payload Operations Control Center for Earth-Orbiting Automated Payloads

Goddard Space Flight Center
Mail Code 513
National Aeronautics and Space Administration
Greenbelt, Maryland 20771

Payload Operations Control Center for Planetary Payloads

Jet Propulsion Laboratory
Mail Code 180-402
4800 Oak Grove Drive
Pasadena, California 91103

APPENDIX B

STS 100 Form

STS 100 FORM (REV C)	REQUEST FOR FLIGHT ASSIGNMENT	DATE:
TO: NATIONAL AERONAUTICS AND SPACE ADMINISTRATION SPACE TRANSPORTATION SYSTEMS UTILIZATION MAIL CODE: MC WASHINGTON, D.C. 20546	FROM: William F. Fratzke, Col, USAF Assistant for Space Transportation & Test USAF Space Division PRINCIPAL CONTACT: Maj Steve Duttry TELEPHONE: (213) 643-1104	
PAYLOAD TITLE: 	USER CATEGORY: <input type="checkbox"/> Other U.S. Government <input type="checkbox"/> ESA <input type="checkbox"/> Domestic commercial <input checked="" type="checkbox"/> DOD <input type="checkbox"/> Foreign commercial <input type="checkbox"/> NASA <input type="checkbox"/> Foreign Government	
FLIGHT TYPE: <input type="checkbox"/> Shared <input type="checkbox"/> Dedicated <input type="checkbox"/> Retrieval <input type="checkbox"/> Revisit/service <input type="checkbox"/> Attached <input type="checkbox"/> Deployable	CARRIER: <input type="checkbox"/> Spacelab (specify) _____ <input type="checkbox"/> Other (specify) _____ <input type="checkbox"/> IUS (specify) _____ <input type="checkbox"/> SSUS-A <input type="checkbox"/> SSUS-D <input type="checkbox"/> MMS	
PAYLOAD OBJECTIVES: 		
PAYLOAD ORBIT REQUIREMENTS: SHUTTLE ORBIT REQUIREMENTS: <input type="checkbox"/> 160NM altitude/28.5° inclination <input type="checkbox"/> 160NM altitude/57° inclination <input type="checkbox"/> NM altitude/ _____ ° inclination CARRIER (OR FINAL) ORBIT REQUIREMENTS (deployable only): <input type="checkbox"/> NM apogee altitude <input type="checkbox"/> NM perigee altitude <input type="checkbox"/> deg inclination <input type="checkbox"/> deg argument of perigee FINAL ORBIT REQUIREMENTS (deployable only): _____ _____ _____		
PAYLOAD LAUNCH DATE(S) REQUESTED (month and year): First launch (scheduled, stand-by or short-term call-up) _____ Second launch (scheduled, stand-by or short-term call-up) _____ Third launch (scheduled, stand-by or short-term call-up) _____ Fourth launch (scheduled, stand-by or short-term call-up) _____ _____ _____		

PAYLOAD MISSION DURATION REQUIRED:

_____ hours/days
_____ no requirement

UNIQUE PAYLOAD CONSTRAINTS:

PAYLOAD CHARACTERISTICS: *

	wgt(lb/kg)	max dia(in/cm)	max lgth(in/cm)	cg(in/cm)
--	------------	----------------	-----------------	-----------

Launch _____

Retrieval/landing _____

Radio frequencies T/M _____ Cmd _____ other _____

* THE TERM PAYLOAD REFERS TO ALL USER PROVIDED EQUIPMENT

QUESTIONNAIRE:

Has earnest money been submitted? _____

Is apportionment/assignment anticipated? _____

List any anticipated optional services you may require. _____

Does your organization have copies of standard STS documentation? _____

REMARKS:

/s/ _____

Title: Asst for Space Transportation & Test

APPENDIX C

Glossary of terms

aft flight deck

That part of the Orbiter cabin on the upper deck where payload controls can be located.

airlock

A compartment, capable of being depressurized without depressurization of the Orbiter cabin, used to transfer crewmembers and equipment. A similar compartment in the Spacelab module is used to expose experiments to space.

announcement of flight opportunity

The process by which proposed investigations are solicited for a specific space flight.

announcement of flight periods

The process by which proposed investigations are solicited for space flight within a designated time period but without a specific flight number identification. The flight period may include plans for one or more flights.

Atlas-Centaur class

Payloads weighing approximately 4000 to 4400 pounds (1800 to 2000 kilograms).

azimuth

True launch heading from KSC or VLS measured clockwise from 0° north.

barbecue mode

Orbiter in slow roll for thermal conditioning.

beta angle

Minimum angle between the Earth-Sun line and the plane of the orbit.

capture

The event of the remote manipulator system end effector making contact with and firmly attaching to a payload grappling fixture. A payload is captured at any time it is firmly attached to the remote manipulator system.

cargo

The total complement of payloads (one or more) on any one flight. It includes everything contained in the Orbiter cargo bay plus other equipment, hardware, and consumables located elsewhere in the Orbiter that are user-unique and are not carried as part of the basic Orbiter payload support.

cargo bay

The unpressurized midpart of the Orbiter fuselage behind the cabin aft bulkhead where most payloads are carried. Its maximum usable payload envelope is 15 feet (4.6 meters) in diameter and 60 feet (18.3 meters) long. Hinged doors extend the full length of the bay.

cargo bay liner

Protective soft material used to isolate sensitive payloads from the bay structure.

cargo integration review

The part of the STS planning process that results in a cargo manifest, cost per flight, and billing schedule.

cargo integration test equipment

Setup at KSC that can provide testing of both payload-to-payload and cargo-to-Orbiter interfaces.

certificate of compliance

Documentation prepared by the user confirming that a payload has successfully completed interface verification.

commander

The crewmember who has ultimate responsibility for the safety of embarked personnel and has authority throughout the flight to deviate from the flight plan, procedures, and personnel assignments as necessary to preserve crew safety or vehicle integrity. The commander is also responsible for the overall execution of the flight plan in compliance with NASA policy, mission rules, and Mission Control Center directives.

common payload support equipment

Spacelab-provided mission-dependent equipment that consists of a top airlock and a viewport/window assembly.

core segment

Section of the pressurized Spacelab module that houses subsystem equipment and experiments.

crew activity planning

The analysis and development of activities to be performed in flight by the crew, resulting in a time line of these activities and reference data for each flight.

deadband

That attitude and rate control region in which no Orbiter reaction control system or vernier correction forces are being generated.

Deep Space Network

Communications network managed by the Jet Propulsion Laboratory for command and control of all planetary flights.

Delta class

Payloads weighing approximately 2000 to 2400 pounds (900 to 1100 kilograms).

deployment

The process of removing a payload from a stowed or berthed position in the cargo bay and releasing that payload to a position free of the Orbiter.

European Space Agency

An international organization acting on behalf of its member states (Belgium, Denmark, France, Federal Republic of Germany, Italy, the Netherlands, Spain, Sweden, Switzerland, and the United Kingdom). The ESA directs a European industrial team responsible for the development and manufacture of Spacelab.

experimenter

A user of the Space Transportation System, ordinarily an individual whose experiment is a small part of the total payload.

experiment racks

Removable and reusable assemblies in the Spacelab module that provide structural mounting and connections to supporting subsystems (power, thermal control, data management, etc.) and experiment equipment.

experiment segment

Section of the pressurized Spacelab module that houses experiments and sensors.

external tank

Element of the Space Shuttle system that contains liquid propellant for the Orbiter main engines. It is jettisoned before orbit insertion.

extravehicular activity

Activities by crewmembers conducted outside the spacecraft pressure hull or within the cargo bay when the cargo bay doors are open.

extravehicular mobility unit

A self-contained (no umbilicals) life support system and anthropomorphic pressure garment for use by crewmembers during extravehicular activity. It provides thermal and micrometeoroid protection.

flight

The period from launch to landing of an Orbiter — a single Shuttle round trip. One flight might deliver more than one payload or more than one flight might be required to accomplish a single mission.

flight control team

That group of MCC personnel on duty to provide real-time support for the duration of each STS flight.

flight data file

The onboard complement of crew activity plans, procedures, reference material, and test data available to the crew for flight execution. Normally, both an STS flight data file for STS crew activities and a payload flight data file for payload crew activities will be onboard.

flight-dependent training

Preparation of a mission or payload specialist(s) for a specific flight, depending on the mission goals. Part of the training involves integrated simulations with the rest of the flightcrew and ground teams.

flight design

The trajectory, consumables, attitude and pointing, and navigation analysis necessary to support the planning of a flight.

flight-independent training

Standard preparation of a mission or payload specialist for any flight.

flight kit

Optional hardware (including consumables) to provide additional, special, or extended services to payloads. Kits are packaged in such a way that they can be installed and removed easily.

flight manifest

The designation of a flight, assignment of the cargo to be flown, and specific implementing instructions for STS operations personnel.

flight phases

Prelaunch, launch, on orbit, deorbit, entry, landing, and postlanding.

flight types

Payload deployment and retrieval, on-orbit servicing of satellites, and on-orbit operations with an attached payload, as suited to the purposes of a mission. A single flight may include more than one of these purposes.

free-flying system

Any satellite or payload that is detached from the Orbiter during operational phases and is capable of independent operation.

igloo

A pressurized container for Spacelab pallet subsystems when no module is used.

inclination

The maximum angle between the plane of the orbit and the equatorial plane.

instrument pointing system

Spacelab hardware and software for precision pointing and stability for experiment equipment.

integration

A combination of activities and processes to assemble payload and STS components, subsystems, and system elements into a desired configuration and to verify compatibility among them.

interface

The mechanical, electrical, and operational common boundary between two elements of a system.

interface verification

Testing of flight hardware interfaces by an acceptable method that confirms that those interfaces are compatible with the affected elements of the Space Transportation System.

inertial upper stage

Solid propulsive upper stage designed to place spacecraft on high Earth orbits or on escape trajectories for planetary missions.

launch pad

The area at which the stacked Space Shuttle undergoes final prelaunch checkout and countdown and from which it is launched.

launch-readiness verification

The process of ensuring the continuing operational capability of the Space Shuttle system, upper stages, and Spacelab.

launch site support manager

The individual at KSC who is the single point of contact with users in arranging payload processing at the launch site.

Long Duration Exposure Facility

Free-flying reusable satellite designed primarily for small passive or self-contained active experiments that require prolonged exposure to space. It is launched in the Orbiter cargo bay and deployed and retrieved by the remote manipulator system.

manned maneuvering unit

A propulsive backpack device for extravehicular activity. It uses a low-thrust, dry, cold nitrogen propellant.

mission

The performance of a coherent set of investigations or operations in space to achieve program goals. A single mission might require more than one flight, or more than one mission might be accomplished on a single flight.

Mission Control Center

Central area at JSC for control and support of all phases of STS flights.

mission-dependent equipment

Spacelab optional equipment that can be added to a flight if needed for the mission involved.

mission-independent equipment

Spacelab subsystem and support equipment that is carried on every Spacelab flight.

mission kit

Flight kit is the preferred term.

mission specialist

The crewmember who is responsible for coordination of overall payload/STS interaction and, during the payload operation phase, directs the allocation of the STS and crew resources to the accomplishment of the combined payload objectives. The mission specialist will have prime responsibility for experiments to which no payload specialist is assigned and/or will assist the payload specialist when appropriate.

mission station

Location on the Orbiter aft flight deck from which payload support operations are performed, usually by the mission specialist.

mixed payloads

Cargo containing more than one type of payload.

mobile launch platform

The structure on which the elements of the Space Shuttle are stacked in the Vehicle Assembly Building and are moved to the launch pad.

mobility aid

Handrails or footrails to help crewmembers move about the spacecraft.

module

Pressurized manned laboratory suitable for conducting science, applications, and technology activities.

module exchange mechanism

Part of the Multimission Modular Spacecraft flight support system that is used for servicing.

Multimission Modular Spacecraft

Free-flying system built in sections so that it can be adapted to many missions requiring Earth-orbiting remote-sensing spacecraft. It is launched in the Orbiter cargo bay and deployed and retrieved by the remote manipulator system.

multipurpose support group

That group of MCC personnel responsible for preflight planning, procedures development, systems expertise, and manpower. During a flight, this group reports systems and trajectory status to the flight control room.

multiuse mission support equipment

Hardware available at the launch site for handling payloads, or common flight hardware used by various payload disciplines.

nadir

That point on the celestial sphere vertically below the observer, or 180° from the zenith.

off-line integration

Assembly of payload elements or multiple payloads that does not involve any STS element.

on-line integration

Mating of payloads with the Orbiter, Spacelab, or upper stage. Level I is with the Orbiter; Level II is with the Spacelab, upper stage, etc.

operations planning

Performing those tasks that must be done to ensure that vehicle systems and ground-based flight control operations support flight objectives.

orbital flight test

One of the first four scheduled developmental space flights of the Space Shuttle system.

orbital maneuvering system

Orbiter engines that provide the thrust to perform orbit insertion, circularization, or transfer; rendezvous; and deorbit.

Orbiter

The manned orbital flight vehicle of the Space Shuttle system.

Orbiter Processing Facility

Building near the Vehicle Assembly Building at KSC with two bays in which the Orbiter undergoes postflight inspection, maintenance, and premate checkout before payload installation. Payloads are also installed horizontally in the Orbiter in this building.

pallet

An unpressurized platform, designed for installation in the Orbiter cargo bay, for mounting instruments and equipment requiring direct space exposure.

pallet train

Two or more pallets rigidly connected to form a single unit.

payload

The total complement of specific instruments, space equipment, support hardware, and consumables carried in the Orbiter (but not included as part of the basic Orbiter payload support) to accomplish a discrete activity in space.

payload assist module

Propulsive upper stage designed to deliver spacecraft of the Delta and Atlas-Centaur classes to Earth orbits beyond the capabilities of the Space Shuttle.

payload canister

Environmentally controlled transporter for use at the launch site. It is the same size and configuration as the Orbiter cargo bay.

payload carrier

One of the major classes of standard payload carriers certified for use with the Space Shuttle to obtain low-cost payload operations. The payload carriers are identified as habitable modules (Spacelab) and attached but uninhabitable modules (pallets, free-flying systems, satellites, and upper stages).

payload changeout room

An environmentally controlled room at the launch pad for inserting payloads vertically into the Orbiter cargo bay.

payload discipline training

Preparation of a mission or payload specialist for handling a specific experiment. This training is usually the responsibility of the user.

Payload Operations Control Center

Central area, located at any of three NASA centers, from which payload operations are monitored and controlled. The user, in many instances, will have direct command of a payload from this control center.

payload preparation room

Facility at the Vandenberg Launch Site for processing and checking payloads.

payload specialist

The crewmember who is responsible for the operation and management of the experiments or other payload elements that are assigned to him or her, and for the achievement of their objectives. The payload specialist will be an expert in experiment design and operation and may or may not be a career astronaut.

payload station

Location on the Orbiter aft flight deck from which payload-specific operations are performed, usually by the payload or mission specialist.

payload supplier

Owner/operator of any Space Shuttle payload.

pilot

The crewmember who is second in command of the flight and assists the commander as required in the conduct of all phases of Orbiter flight.

planning operations management team

That group of MCC personnel that performs preflight functions and assists the user in requesting facilities, software, command, telemetry, and flight requirements and POCC interfaces.

principal investigator

Research scientist who is in charge of the conduct of an experiment carried by any STS element.

program

An activity involving manpower, material, funding, and scheduling necessary to achieve desired goals.

reaction control subsystem

Thrusters on the Orbiter that provide attitude control and three-axis translation during orbit insertion, on-orbit, and reentry phases of flight.

remote manipulator system

Mechanical arm on the cargo bay longeron. It is controlled from the Orbiter aft flight deck to deploy, retrieve, or move payloads.

retrieval

The process of using the remote manipulator system and/or other handling aids to return a captured payload to a stowed or berthed position. No payload is considered retrieved until it is fully stowed for safe return or berthed for repair and maintenance tasks.

simulator

A heavily computer-dependent training facility that imitates flight hardware responses.

solid rocket boosters

Element of the Space Shuttle that consists of two solid rocket motors to augment ascent thrust at launch. They are separated from the Orbiter soon after lift-off and recovered for reuse.

Spacelab

A general-purpose orbiting laboratory for manned and automated activities in near-Earth orbit. It includes both module and pallet sections, which can be used separately or in several combinations.

Space Shuttle

Orbiter, external tank, and two solid rocket boosters.

Space Flight Tracking and Data Network

A number of ground-based stations having direct communications with NASA flight vehicles.

Space Transportation System

An integrated system consisting of the Space Shuttle (Orbiter, external tank, solid rocket booster, and flight kits), upper stages, Spacelab, and any associated flight hardware and software.

stability rate

The maximum angular rate error during steady-state limit-cycle operation.

stowing

The process of placing a payload in a retained position in the cargo bay for ascent or return from orbit.

tilt/spin table

Mechanism installed in the Orbiter cargo bay that deploys the payload assist module with its spacecraft.

Tracking and Data Relay Satellite System

Two-satellite communication system providing principal coverage from geosynchronous orbit for all STS flights.

trainer

A training device or facility that primarily provides a physical representation of flight hardware. It may have limited computer capabilities.

upper stage

Payload assist module or inertial upper stage. Both are designed for launch from the Orbiter cargo bay and have propulsive elements to deliver payloads into orbits and trajectories beyond the capabilities of the Shuttle.

user

An organization or individual requiring the services of the Space Transportation System.

utilization planning

The analysis of approved (funded or committed) payloads with operational resources, leading to a set of firm flight schedules with cargo manifests.

Vehicle Assembly Building

High-bay building near KSC launch pad in which the Shuttle elements are stacked onto the mobile launch platform. It is also used for vertical storage of the external tanks.

VAFB NASA Resident Office
NASA operations at Vandenberg Air Force Base.

zenith
That point of the celestial sphere vertically overhead. The point 180° from the zenith is called the nadir.

APPENDIX D

Acronyms

ADA	array deployment assembly
AMPS	atmospheric magnetospheric plasma system
APP	astrophysics payload
ASE	airborne support equipment
ATL	advanced technology laboratory
BLS	Bureau of Labor Statistics
BN	ballistic number
CAP	crew activity plan
c.g.	center of gravity
CIR	cargo integration review
CITE	cargo integration test equipment
CPC	compact payload carrier
CRT	cathode-ray tube
DOD	Department of Defense
Domsat	domestic satellite
DSN	Deep Space Network
ECS	environmental control system
ESA	European Space Agency
ETR	Eastern Test Range
EVA	extravehicular activity
FDS	flight data system
FM	frequency modulation
FSS	flight support system
GAS	getaway special
GSE	ground support equipment
GSFC	NASA Goddard Space Flight Center
GSTDN	Ground Space Flight Tracking and Data Network
HPF	Hazardous Processing Facility
HRM	high-rate multiplexer
ICD	Interface Control Document
IMU	inertial measurement unit
I/O	input/output
IPS	instrument pointing system
IUS	inertial upper stage
JPL	Jet Propulsion Laboratory
JSC	NASA Lyndon B. Johnson Space Center
KSC	NASA John F. Kennedy Space Center
LaRC	NASA Langley Research Center
LDEF	Long Duration Exposure Facility
LSSM	launch site support manager
MCC	Mission Control Center
MMS	Multimission Modular Spacecraft
MSS	mission specialist station
Nascom	NASA communications network
O&C	Operation and Checkout Building

OMCF	Orbiter Maintenance and Checkout Facility
OMS	orbital maneuvering system
OPF	Orbiter Processing Facility
PAM	payload assist module
PAM-A	payload assist module for Atlas-Centaur class spacecraft
PAM-D	payload assist module for Delta class spacecraft
PCR	payload changeout room
PEP	power extension package
PETS	Payload Environmental Transportation System
PGHM	payload ground handling mechanism
PIP	Payload Integration Plan
PM	phase modulation
POCC	Payload Operations Control Center
POMT	planning operations management team
POP	perpendicular to orbit plane
PPF	Payload Preparation Facility
PPR	payload preparation room
PRCA	power regulation control assembly
PSK	phase shift keying
PSS	payload specialist station
RAU	remote acquisition unit
RCS	reaction control system
RMS	remote manipulator system
RSS	rotating service structure
SAEF	Spacecraft Assembly and Encapsulation Facility
SAMSO	Space and Missile Systems Organization (USAF)
SDF	Safing and Deservicing Facility
SLS	Spacelab simulator
SMAB	Solid Motor Assembly Building
SMM	solar maximum mission
SMS	Shuttle mission simulator
SPIF	Shuttle POCC Interface Facility
SPP	solar physics payload
SRB	solid rocket booster
SSCP	small self-contained payload
SST	single system trainer
STDN	Space Flight Tracking and Data Network
STS	Space Transportation System
TBD	to be determined
TDRS	Tracking and Data Relay Satellite
TDRSS	Tracking and Data Relay Satellite System
VAB	Vehicle Assembly Building
VAFB	Vandenberg Air Force Base
VLS	Vandenberg Launch Site
VPF	Vertical Processing Facility
VPHD	vertical payload handling device