

PDRS Operations Checklist

STS-114 Flight Supplement

**Mission Operations Directorate
EVA, Robotics, & Crew Systems
Operations Division**

**Basic, Rev A
August 27, 2004**

National Aeronautics and
Space Administration

Lyndon B. Johnson Space Center
Houston, Texas



MISSION OPERATIONS DIRECTORATE

**PDRS OPERATIONS CHECKLIST
STS-114 FLIGHT SUPPLEMENT**

BASIC, REV A
August 27, 2004

PREPARED BY:

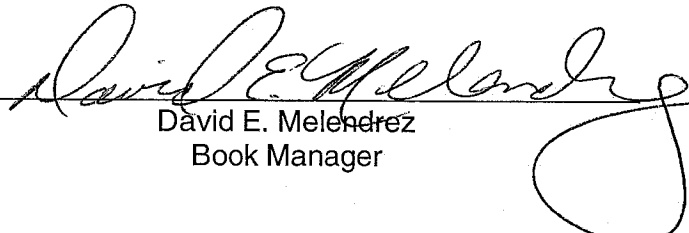

David E. Melendrez
Book Manager

APPROVED BY:

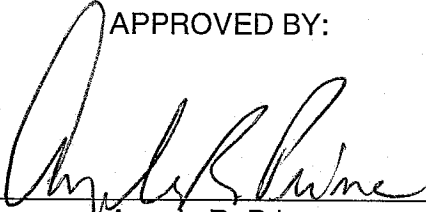

Angela R. Prince
Lead, Robotics Systems Group



Daniel D. Lindner
Chief, Robotics Operations Branch

This document is under the configuration control of the Crew Procedures Control Board (CPCB). Except for Discrepancy Notices (DN) approved at the flight operations review (FOR), all proposed changes must be submitted via FDF Workflow Crew Procedure Change Request (CR) to DO3/FDF Manager.

Additional distribution of this book, for official use only, may be requested in writing to DO3/FDF Manager. The request must include justification and requester's name, organization, position, and phone number. Contractor requests are made through the NASA or DOD organization supported. Deletions, reduction in quantity, or change of address may be submitted to DO3/FDF Management Office, 281-244-1184. E-mail: [name]@jsc.nasa.gov.

Incorporates the following:
482#: NONE – Establishes baseline

AREAS OF TECHNICAL RESPONSIBILITY

Book Manager	DX22/D. Melendrez	281-483-0621
RMS Procedures	DX22/D. Melendrez	281-483-0621
	DX22/L. Hammond	281-483-0348
	DX22/J. Reisman	281-483-0839
	DX22/R. Pritchard	281-483-2642
	DX22/F. Jurgens	281-244-5448
	DX22/M. Wright	281-483-4798
RMS Training	DX25/J. Sugar	281-244-8598
RMS Analysis	DX24/D. Clark	281-483-1103
PRLA/ROEU Procedures	DF52/J. Jason	281-483-7575

PDRS OPERATIONS CHECKLIST
 STS-114 FLIGHT SUPPLEMENT

LIST OF EFFECTIVE PAGES

BASIC 07/19/02
 REV A 08/27/04

Sign Off.....	*	114/BAS A	FS 6-2.....	114/BAS A
FS ii.....	*	114/BAS A	FS 6-3.....	114/BAS A
FS iii.....	*	114/BAS A	FS 6-4.....	114/BAS A
FS iv.....	*	114/BAS A	FS 6-5.....	114/BAS A
FS v.....		114/BAS A	FS 6-6.....	114/BAS A
FS vi.....		114/BAS A	FS 6-7.....	114/BAS A
FS 1-1.....		114/BAS A	FS 6-8.....	114/BAS A
FS 1-2.....		114/BAS A	FS 6-9.....	114/BAS A
FS 1-3.....		114/BAS A	FS 6-10.....	114/BAS A
FS 1-4.....		114/BAS A	FS 6-11.....	114/BAS A
FS 1-5.....		114/BAS A	FS 6-12.....	114/BAS A
FS 1-6.....		114/BAS A	FS 6-13.....	114/BAS A
FS 1-7.....		114/BAS A	FS 6-14.....	114/BAS A
FS 1-8.....		114/BAS A	FS 6-15.....	114/BAS A
FS 1-9.....		114/BAS A	FS 6-16.....	114/BAS A
FS 1-10.....		114/BAS A	FS 7-1.....	114/BAS A
FS 1-11.....		114/BAS A	FS 7-2.....	114/BAS A
FS 1-12.....		114/BAS A	FS 7-3.....	114/BAS A
FS 1-13.....		114/BAS A	FS 7-4.....	114/BAS A
FS 1-14.....		114/BAS A	FS 7-5.....	114/BAS A
FS 1-15.....		114/BAS A	FS 7-6.....	114/BAS A
FS 1-16.....		114/BAS A	FS 7-7.....	114/BAS A
FS 2-1.....		114/BAS A	FS 7-8.....	114/BAS A
FS 2-2.....		114/BAS A	FS 7-9.....	114/BAS A
FS 3-1.....		114/BAS A	FS 7-10.....	114/BAS A
FS 3-2.....		114/BAS A	FS 8-1.....	114/BAS A
FS 4-1.....		114/BAS A	FS 8-2.....	114/BAS A
FS 4-2.....		114/BAS A	FS 8-3.....	114/BAS A
FS 4-3.....		114/BAS A	FS 8-4.....	114/BAS A
FS 4-4.....		114/BAS A	FS 8-5.....	114/BAS A
FS 4-5.....		114/BAS A	FS 8-6.....	114/BAS A
FS 4-6.....		114/BAS A	FS 8-7.....	114/BAS A
FS 4-7.....		114/BAS A	FS 8-8.....	114/BAS A
FS 4-8.....		114/BAS A	FS 8-9.....	114/BAS A
FS 4-9.....		114/BAS A	FS 8-10.....	114/BAS A
FS 4-10.....		114/BAS A	FS 8-11.....	114/BAS A
FS 4-11.....		114/BAS A	FS 8-12.....	114/BAS A
FS 4-12.....		114/BAS A	FS 8-13.....	114/BAS A
FS 5-1.....		114/BAS A	FS 8-14.....	114/BAS A
FS 5-2.....		114/BAS A	FS 8-15.....	114/BAS A
FS 5-3.....		114/BAS A	FS 8-16.....	114/BAS A
FS 5-4.....		114/BAS A	FS 8-17.....	114/BAS A
FS 5-5.....		114/BAS A	FS 8-18.....	114/BAS A
FS 5-6.....		114/BAS A	FS 8-19.....	114/BAS A
FS 6-1.....		114/BAS A	FS 8-20.....	114/BAS A

* – Omit from flight book

FS 8-21	114/BAS A	FS 9-21.....	114/BAS A
FS 8-22	114/BAS A	FS 9-22.....	114/BAS A
FS 8-23	114/BAS A	FS 9-23.....	114/BAS A
FS 8-24	114/BAS A	FS 9-24.....	114/BAS A
FS 9-1	114/BAS A	FS 10-1.....	114/BAS A
FS 9-2	114/BAS A	FS 10-2.....	114/BAS A
FS 9-3	114/BAS A	FS 10-3.....	114/BAS A
FS 9-4	114/BAS A	FS 10-4.....	114/BAS A
FS 9-5	114/BAS A	FS 10-5.....	114/BAS A
FS 9-6	114/BAS A	FS 10-6.....	114/BAS A
FS 9-7	114/BAS A	FS 10-7.....	114/BAS A
FS 9-8	114/BAS A	FS 10-8.....	114/BAS A
FS 9-9	114/BAS A	FS 10-9.....	114/BAS A
FS 9-10	114/BAS A	FS 10-10.....	114/BAS A
FS 9-11	114/BAS A	FS 11-1.....	114/BAS A
FS 9-12	114/BAS A	FS CC 11-2.....	114/BAS A
FS 9-13	114/BAS A	FS CC 11-3.....	114/BAS A
FS 9-14	114/BAS A	FS CC 11-4.....	114/BAS A
FS 9-15	114/BAS A	FS CC 11-5.....	114/BAS A
FS 9-16	114/BAS A	FS CC 11-6.....	114/BAS A
FS 9-17	114/BAS A	FS CC 11-7.....	114/BAS A
FS 9-18	114/BAS A	FS CC 11-8.....	114/BAS A
FS 9-19	114/BAS A	FS CC 11-9.....	114/BAS A
FS 9-20	114/BAS A	FS 11-10.....	114/BAS A

PDRS CUE CARDS

<u>Title</u>	<u>Ref. Page</u>	<u>Card No.</u>
MPLM SJ GRAPPLE IN BAY WRIST		
CCTV OVERLAY	FS CC 11-2	PDRS-7a/114/O/A
MPLM SJ UNGRAPPLE ON NODE NADIR WRIST		
CCTV OVERLAY	FS CC 11-3	PDRS-8a/114/O/A
MPLM SJ GRAPPLE ON NODE NADIR WRIST		
CCTV OVERLAY	FS CC 11-4	PDRS-9a/114/O/A
MPLM SJ UNGRAPPLE IN BAY WRIST		
CCTV OVERLAY	FS CC 11-5	PDRS-10a/114/O/A
MPLM BERTH OVERLAY.....	FS CC 11-6	PDRS-11a/114/O/A
SJ BERTH KEEL CCTV OVERLAY.....	FS CC 11-7	PDRS-12a/114/O/A
CBCS CCTV OVERLAY	FS CC 11-8	PDRS-13a/114/O/A
OVERLAY FOR ROEU PL SEL POSITION.....	FS CC 11-9	PDRS-14a/114/O/A

<u>CONTENTS</u>	<u>PAGE</u>
<u>OBSS NOMINAL</u>	FS 1-1
OBSS UNBERTH.....	FS 1-2
BERTH.....	FS 1-5
HANDOFF FROM SSRMS TO PARK.....	FS 1-8
PARK TO SSRMS.....	FS 1-12
<u>TPS SURVEYS (TBS)</u>	FS 2-1
OBSS LDRI RCC SURVEY – STBD	
– PORT	
– NOSE CAP	
SRMS EE CAM UPPER SURFACE SURVEY	
<u>OBSS CONTINGENCY (TBS)</u>	FS 3-1
OBSS SJ GRAPPLE	
UNBERTH	
BERTH	
UNGRAPPLE	
JETTISON	
ITVC RCC SURVEY – STBD	
– PORT	
– NOSE CAP	
<u>ORBITER REPAIR</u>	FS 4-1
ORM DTO (TBS)	
ORBITER REPAIR MANEUVER (CONTINGENCY).....	FS 4-3
REVERSE ORBITER REPAIR MANEUVER (CONTINGENCY).....	FS 4-8
<u>INSPECTION AND REPAIR REFERENCE DATA</u>	FS 5-1
OBSS JOINT ANGLES VS POR COORDINATES (TBS)	
AUTO SEQUENCES (TBS)	
COORDINATE SYSTEM – PL ID 1 (TBS)	
2 (TBS)	
3 (TBS)	
4 (TBS)	
GO/NO-GO CRITERIA (TBS)	
ATTITUDE CONTROL CONSTRAINTS (TBS)	
SRMS EE CAM JOINT ANGLES VS POR COORDINATES (TBS)	
AUTO SEQUENCE (TBS)	
COORDINATE SYSTEM – PL ID 5 (TBS)	
ORM JOINT ANGLES VS POR COORDINATES.....	FS 5-3
AUTO SEQUENCES.....	FS 5-4
COORDINATE SYSTEM – PL ID 4A (UPLINK) (TBS)	
5A (UPLINK) (TBS)	
GO/NO-GO CRITERIA (TBS)	
ATTITUDE CONTROL CONSTRAINTS (TBS)	
<u>NOMINAL MPLM INSTALL (CONTINGENCY)</u>	FS 6-1
NODE 1 NADIR ACBM INSPECTION (CONTINGENCY).....	FS 6-2
MPLM GRAPPLE IN BAY (CONTINGENCY).....	FS 6-3
ROEU DEMATE (CONTINGENCY).....	FS 6-5
UNBERTH (CONTINGENCY).....	FS 6-7
INSTALL (CONTINGENCY).....	FS 6-11
UNGRAPPLE ON NODE NADIR (CONTINGENCY).....	FS 6-16

<u>NOMINAL MPLM BERTH (CONTINGENCY)</u>	FS 7-1
MPLM GRAPPLE ON NODE NADIR (CONTINGENCY)	FS 7-2
UNINSTALL (CONTINGENCY)	FS 7-4
BERTH (CONTINGENCY)	FS 7-6
ROEU MATE (CONTINGENCY)	FS 7-8
UNGRAPPLE IN BAY (CONTINGENCY)	FS 7-10
<u>OFF-NOMINAL MPLM INSTALL (CONTINGENCY)</u>	FS 8-1
MPLM SJ GRAPPLE IN BAY (CONTINGENCY)	FS 8-2
UNBERTH (CONTINGENCY)	FS 8-9
INSTALL (CONTINGENCY)	FS 8-14
UNGRAPPLE ON NODE NADIR (CONTINGENCY)	FS 8-22
JETTISON (CONTINGENCY)	FS 8-24
<u>OFF-NOMINAL MPLM BERTH (CONTINGENCY)</u>	FS 9-1
MPLM SJ GRAPPLE ON NODE NADIR (CONTINGENCY)	FS 9-2
UNINSTALL (CONTINGENCY)	FS 9-9
BERTH (CONTINGENCY)	FS 9-14
UNGRAPPLE IN BAY (CONTINGENCY)	FS 9-23
<u>MPLM REFERENCE DATA (CONTINGENCY)</u>	FS 10-1
JOINT ANGLES VS POR COORDINATES (CONTINGENCY)	FS 10-2
MPLM GRAPPLE IN BAY (CONTINGENCY)	FS 10-2
CLEAR V-GUIDES (CONTINGENCY)	FS 10-2
LOW HOVER (CONTINGENCY)	FS 10-2
HIGH HOVER (CONTINGENCY)	FS 10-2
PRE-INSTALL (CONTINGENCY)	FS 10-3
READY-TO-LATCH (CONTINGENCY)	FS 10-3
INSTALLED (CONTINGENCY)	FS 10-3
CLEAR CBM GUIDES (CONTINGENCY)	FS 10-3
MPLM COORDINATE SYSTEM – PL ID 1 (CONTINGENCY)	FS 10-4
2 (CONTINGENCY)	FS 10-5
3 (CONTINGENCY)	FS 10-6
PRLA CONFIGURATION (CONTINGENCY)	FS 10-7
NODE 1 NADIR CBM RTL CONFIG FOR MPLM (CONTINGENCY)	FS 10-8
RMS/MPLM GO/NO-GO CRITERIA (CONTINGENCY)	FS 10-9
SRMS/MPLM ATTITUDE CONTROL CONSTRAINTS (CONTINGENCY)	FS 10-10
<u>CUE CARD CONFIGURATION</u>	FS 11-1

OBSS NOMINAL

OBSS UNBERTH.....	FS 1-2
BERTH.....	FS 1-5
HANDOFF FROM SSRMS TO PARK	FS 1-8
PARK TO SSRMS	FS 1-12

OBSS NOMINAL

OBSS UNBERTH

NOTE

This procedure uses the SRMS to unbearth the OBSS during the undocked timeframe. Assumes stbd MPMs deployed

1. SETUP

MON 1	Elbow
MON 2	D/C

SM 94 PDRS CONTROL

- √ PL ID, ITEM 3: 0
- √ INIT ID, ITEM 24: 0

RHC
A8U

2. MNVR TO OBSS PREGRAPPLE

- RATE – as desired (VERN within 10 ft)
- BRAKES – OFF (tb-OFF)
- MODE – ORB UNL, ENTER

If first RMS ops for the mission:

Perform manual PLB survey, en route to OBSS PREGRAPPLE position

Mnvr to OBSS PREGRAPPLE posn:

X	Y	Z	PITCH	YAW	ROLL	PL ID
-680	+96	-513	270	350	1	0
SY	SP	EP	WP	WY	WR	
-90.0	+87.6	-129.5	-57.5	0.0	+110.4	

BRAKES – ON (tb-ON)

- STBD RMS HTR (two) – OFF
- R12(OBSS) √ SPEE PWR – OFF

3. OBSS GRAPPLE

MON 1	Wrist
MON 2	D/C

A7U

- CCTV – config for grapple
- install PDRS TARGET OVERLAY FOR CTVM
- RMS WRIST, zoom 34.0 HFOV
focus 5 ft

Maintain eyepoint ~18 in when using grapple overlay

RHC
A8U

- RATE – VERN (RATE MIN tb-ON)
- BRAKES – OFF (tb-OFF)
- MODE – END EFF, ENTER

Mnvr to grapple envelope

CAUTION
Monitor EE tb timing to prevent EE motor burnout

- EE MODE – AUTO
- CAPTURE – depress (mom)

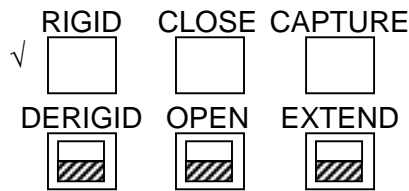

CRITICAL TIMES (28 sec total)
 CAPTURE tb – gray, then
 CLOSE tb – gray, 3 sec max, then
 RIGID tb – gray, 25 sec max

EE MODE – OFF
 BRAKES – ON (tb-ON)

SM 94 PDRS CONTROL
 PL ID – ITEM 3 +1 EXEC
 INIT ID – ITEM 24 +1 EXEC

Record POSN/ATT and Joint Angles:

	X	Y	Z	PITCH	YAW	ROLL	PL ID
							1
Expected	-1257	+105	-436	360	360	340	1
	SY	SP	EP	WP	WY	WR	
Expected	-90.0	+76.5	-134.5	-41.0	0.0	+110.0	

Review GENERIC END EFFECTOR CUE CARD – SHUTTLE NOT DOCKED OPS

4. CONFIGURE POWER

MA73C:C cb MCA PWR AC2 3Φ MID 2 – cl
 :D AC3 3Φ MID 4 – cl

R13L PL BAY MECH PWR SYS (two) – ON

5. MRL RELEASE

SM 94 PDRS CONTROL
 RMS STBD – ITEM 2 EXEC (*)
 ✓AFT, MID, FWD (six) = 0

- * If any MSW shows '1', drive MRL *
- * for single motor time (tbd sec) *

A6 DAP: VERN (FREE)

STBD RMS RETEN LAT – REL (tb-REL) (18 sec max)
 – OFF

If motor drive time > 8 sec, ✓MCC

SM 94 PDRS CONTROL
 RMS PORT – ITEM 1 EXEC (*)

6. RECONFIGURE POWER

R13L PL BAY MECH PWR SYS (two) – OFF

MA73C:C cb MCA PWR AC2 3Φ MID 2 – op
 :D AC3 3Φ MID 4 – op

Record joint angles:

SY	SP	EP	WP	WY	WR

- A7U 7. MNVR TO OBSS HOVER
CCTV – config for unberth

MON 1	Elbow
MON 2	D/C

- RHC
A8U √RATE – VERN (RATE MIN tb-ON)
BRAKES – OFF (tb-OFF)
MODE – PL, ENTER

Mnvr OBSS up (-Z) to OBSS HOVER, Z = -496

X	Y	Z	PITCH	YAW	ROLL	PL ID
-1257	+126	-496	360	360	340	1
SY	SP	EP	WP	WY	WR	
-90.0	+79.7	-123.0	-55.7	0.0	+110.0	

- BRAKES – ON (tb-ON)
√MODE – not DIRECT
JOINT – CRIT TEMP

- A6U DAP: as reqd

Perform ACTIVATION (LDRI/ITVC Cue Card, PHOTO/TV)

OBSS BERTH

NOTE

This procedure uses the SRMS to berth the OBSS during the undocked timeframe. Assume STBD MPMs are deployed

- A7U 1. SETUP
CCTV – config for berth

MON 1	Elbow
MON 2	D/C

SM 94 PDRS CONTROL
PL ID – ITEM 3 +2 EXEC
INIT ID – ITEM 24 +2 EXEC

- RHC 2. MNVR TO OBSS HOVER
A8U RATE – VERN (RATE MIN tb-ON)
BRAKES – OFF (tb-OFF)
MODE – ORB LD, ENTER

Mnvr to OBSS HOVER posn:

X	Y	Z	PITCH	YAW	ROLL	PL ID
-1257	+126	-495	360	0	341	1
-970	+128	-514	360	0	360	2
SY	SP	EP	WP	WY	WR	
-90.0	+80.4	-123.7	-55.7	0.0	+110.0	

BRAKES – ON (tb-ON)
√STBD RMS HTR (two) – OFF

Perform DEACTIVATION (LDRI/ITVC Cue Card, PHOTO/TV)

- A6 3. OBSS BERTH
SM 94 PDRS CONTROL
PL ID – ITEM 3 +1 EXEC
INIT ID – ITEM 24 +1 EXEC
RMS STBD – ITEM 2 EXEC (*)

DAP: VERN (FREE)
BRAKES – OFF (tb-OFF)
MODE – PL, ENTER

NOTE

Refer to table in OBSS UNBERTH, step 3 for joint angles at GRAPPLE to fill in table below

Mnvr OBSS down (+Z) to OBSS BERTH

	X	Y	Z	PITCH	YAW	ROLL	PL ID
Expected	-1257	+105	-436	360	360	341	1
	SY	SP	EP	WP	WY	WR	1
Expected	-90.0	+76.5	-134.5	-41.0	0.0	+110.0	

√STBD R-F-L tb (three) – gray

4. CONFIGURE POWER

MA73C:C cb MCA PWR AC2 3Φ MID 2 – cl
:D AC3 3Φ MID 4 – cl

R13L PL BAY MECH PWR SYS (two) – ON

5. MRL LATCH

SM 94 PDRS CONTROL

√AFT, MID, FWD (six) = 0

- * If any MSW shows ‘1’, drive MRL *
- * for single motor time (18 sec) *

A8L STBD RMS RETEN LAT – LAT (tb-LAT) (18 sec max)
– OFF

If motor drive time > 8 sec, √MCC

BRAKES – ON (tb-ON)

DAP: as reqd

SM 94 PDRS CONTROL

RMS PORT – ITEM 1 EXEC (*)

6. RECONFIGURE POWER

R13L PL BAY MECH PWR SYS (two) – OFF

7. OBSS UNGRAPPLE

A7U CCTV – config for ungrapple
– RMS WRIST, zoom 34.0 HFOV
focus 5 ft

MON 1	Wrist
MON 2	D/C

SM 94 PDRS CONTROL



















PL ID – ITEM 3 +0 EXEC
INIT ID – ITEM 24 +0 EXEC

√RATE – VERN (RATE MIN tb-ON)
 BRAKES – OFF (tb-OFF)
 MODE – END EFF, ENTER

CAUTION
 Monitor EE tb timing to prevent EE motor burnout

EE MODE – AUTO
 RELEASE sw – REL (mom)

When OPEN tb – gray, slowly mnvr arm clear of grapple pin

	<u>CRITICAL TIMES (28 sec total)</u>													
<table style="width: 100%; border-collapse: collapse;"> <tr> <td style="text-align: center;">RIGID</td> <td style="text-align: center;">CLOSE</td> <td style="text-align: center;">CAPTURE</td> </tr> <tr> <td style="text-align: center;">√ </td> <td style="text-align: center;"></td> <td style="text-align: center;"></td> </tr> <tr> <td style="text-align: center;">DERIGID</td> <td style="text-align: center;">OPEN</td> <td style="text-align: center;">EXTEND</td> </tr> <tr> <td style="text-align: center;"></td> <td style="text-align: center;"></td> <td style="text-align: center;"></td> </tr> </table>	RIGID	CLOSE	CAPTURE	√ 			DERIGID	OPEN	EXTEND				DERIGID tb – gray, 5 sec max, then OPEN tb – gray, 3 sec max, then EXTEND tb – gray, 20 sec max	
RIGID	CLOSE	CAPTURE												
√ 														
DERIGID	OPEN	EXTEND												
														

EE MODE – OFF

- * If manual release reqd: *
- * EE MODE – MAN *
- * MAN CONTR – DERIGID (hold until DERIGID tb-gray, 5 sec max) *
- * RELEASE sw – depress (hold until OPEN tb-gray, 3 sec max) *
- * Mnvr arm clear, then *
- * EE MAN CONTR – DERIGID (hold until EXTEND tb-gray, 20 sec max) *
- * MODE – OFF *

STBD RMS HTR (two) – AUTO

DAP: as reqd

Mnvr to OBSS PREGRAPPLE posn:

X	Y	Z	PITCH	YAW	ROLL	PL ID
-680	+96	-513	270	350	1	0
SY	SP	EP	WP	WY	WR	
-90.0	+87.6	-129.5	-57.5	0.0	+110.4	

BRAKES – ON (tb-ON)
 √MODE – not DIRECT
 JOINT – CRIT TEMP

OBSS HANDOFF FROM SSRMS TO PARK

1. SETUP

SM 94 PDRS CONTROL

√PL ID, ITEM 3: 0

√INIT ID, ITEM 24: 0

A7U

CCTV – config as reqd

MON 1	S1LOOB
MON 2	B (A)

2. PRE-GRAPPLE MANEUVER

On SSRMS Operator GO for mnvr to OBSS PRE-GRAPPLE:

RATE – as reqd (VERN within 10 ft)

BRAKES – OFF (tb-OFF)

MODE – ORB UNL, ENTER

Mnvr to OBSS PRE-GRAPPLE posn:

X	Y	Z	PITCH	YAW	ROLL	PL ID
-1015	-362	-688	284	360	270	0
SY	SP	EP	WP	WY	WR	
+23.5	+63.5	-29.6	-102.9	+11.5	-98.6	

BRAKES – ON (tb-ON)

Give SSRMS Operator GO for OBSS Unberth

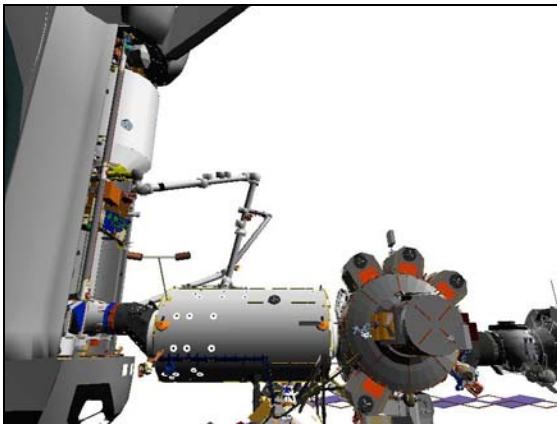

S1 LOWER OUTBOARD (90,20)

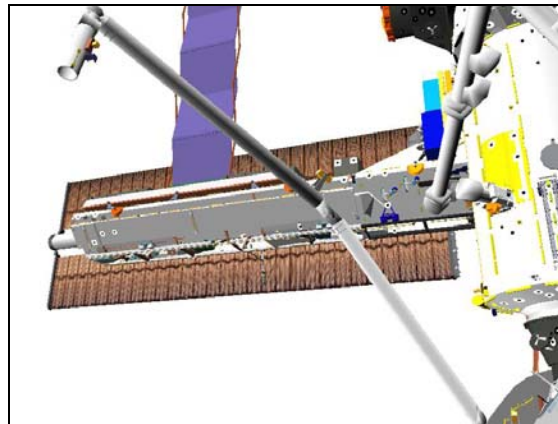

CCTV B (-20,20)



CCTV A (0,28)

- A7U
3. SETUP FOR GRAPPLE
 CCTV – config for grapple
 – install PDRS TARGET OVERLAY FOR CTVM
 – RMS WRIST, zoom 34.0 HFOV
 focus 5 ft
 Maintain eyepoint approx 18 in when using grapple overlay

MON 1	B (Elbow)
MON 2	EE

R12(OBSS) √SPEE PWR – OFF

4. OBSS GRAPPLE AT HANDOFF POSITION
 On SSRMS Operator GO for SRMS OBSS Grapple:
 RATE – VERN (RATE MIN tb-ON)
 BRAKES – OFF (tb-OFF)
 MODE – END EFF, ENTER

Mnvr to grapple envelope

CAUTION
 Monitor EE tb timing to prevent EE motor burnout

EE MODE – AUTO
 CAPTURE sw – depress (mom)

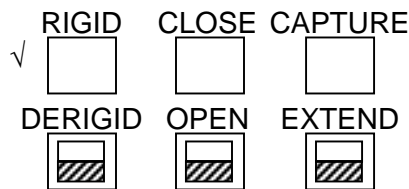

CRITICAL TIMES (28 sec total)
 CAPTURE tb – gray, then
 CLOSE tb – gray, 3 sec max, then
 RIGID tb – gray, 25 sec max

EE MODE – OFF

MODE – TEST, ENTER
 Wait 5 sec

BRAKES – ON (tb-ON)

SM 94 PDRS CONTROL

PL ID – ITEM 3 +2 EXEC

INIT ID – ITEM 24 +2 EXEC

Expected GRAPPLE AT HANDOFF posn:

X	Y	Z	PITCH	YAW	ROLL	PL ID
-1032	-362	-618	284	0	270	0
-1032	-72	-618	24	270	0	2
SY	SP	EP	WP	WY	WR	
+25.8	+66.2	-48.8	-86.2	+10.9	-100.3	

R12(OPP) √cb OBSS SW PWR – cl

√OBSS SW PWR – ON

R12(OBSS) SPEE PWR – ON

Give SSRMS Operator GO for OBSS Ungrangle

Review GENERIC END EFFECTOR CUE CARD – ISS/SHUTTLE DOCKED OPS

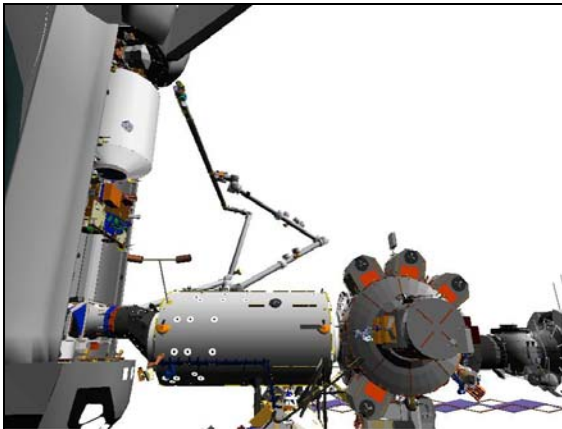

S1 LOWER OUTBOARD (90,20)

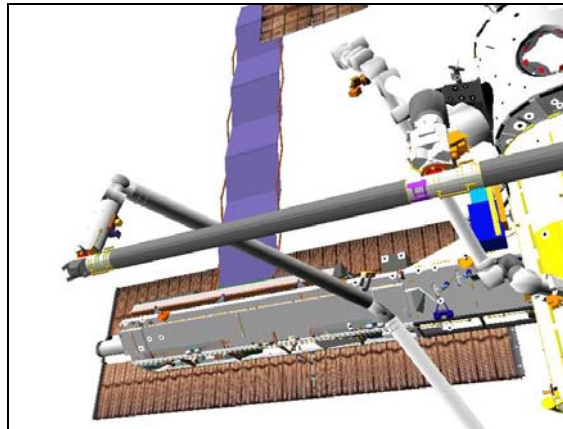

CCTV B (-25,30)



ELBOW (-20,-20)

5. MNVR TO OBSS PARK

On SSRMS Operator GO for mnvr to OBSS Park:

MON 1	S1LOOB(A)
MON 2	B(Elbow)

RATE – as desired (VERN within 10 ft)

BRAKES – OFF (tb-OFF)

MODE – ORB LD, ENTER

Mnvr to OBSS PARK:

X	Y	Z	PITCH	YAW	ROLL	PL ID
-629	-717	-795	91	4	255	2
SY	SP	EP	WP	WY	WR	
+94.9	+38.7	-22.8	-0.5	-0.3	+22.3	

BRAKES – ON (tb-ON)

√MODE – not DIRECT

PARAM sel – PORT TEMP

JOINT sel – CRIT TEMP

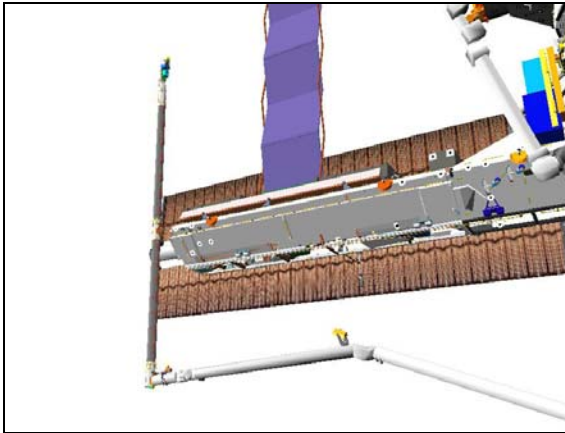

CCTV B (-25,30)

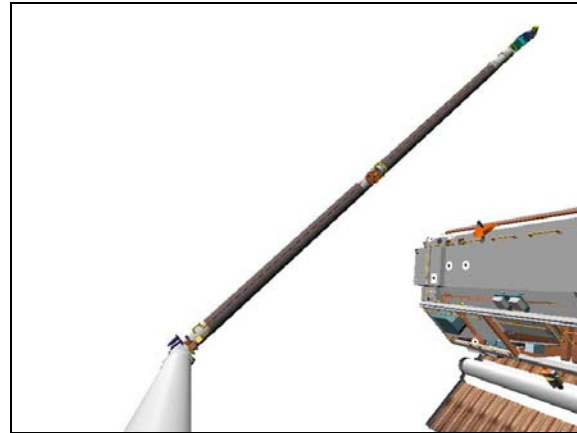

ELBOW (15,15)

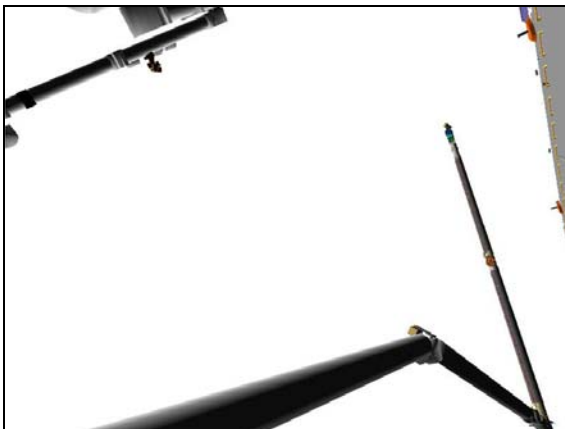

CCTV A (55,35)

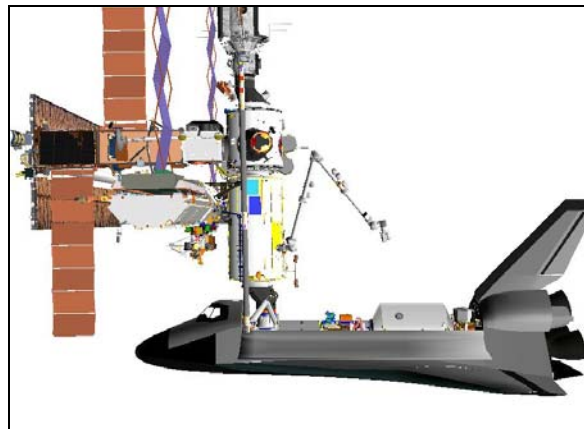

PORT

OBSS HANDOFF FROM PARK TO SSRMS

1. SETUP

SM 94 PDRS CONTROL

√PL ID, ITEM 3: 2

√INIT ID, ITEM 24: 2

A7U

CCTV – config as reqd

MON 1	B(Elbow)
MON 2	A (S1LOOB)

Review GENERIC END EFFECTOR CUE CARD – ISS/SHUTTLE DOCKED OPS

2. MANEUVER TO HANDOFF

On SSRMS Operator GO for mnvr to Handoff:

RATE – as reqd (VERN within 10 ft)

BRAKES – OFF (tb-OFF)

MODE – ORB LD, ENTER

Mnvr to Handoff posn:

X	Y	Z	PITCH	YAW	ROLL	PL ID
-1032	-72	-618	294	270	270	2
SY	SP	EP	WP	WY	WR	
+25.7	+66.2	-48.7	-86.5	+11.0	-100.1	

BRAKES – ON (tb-ON)

R12(OBSS) SPEE PWR – OFF

Give SSRMS Operator GO for OBSS Grapple

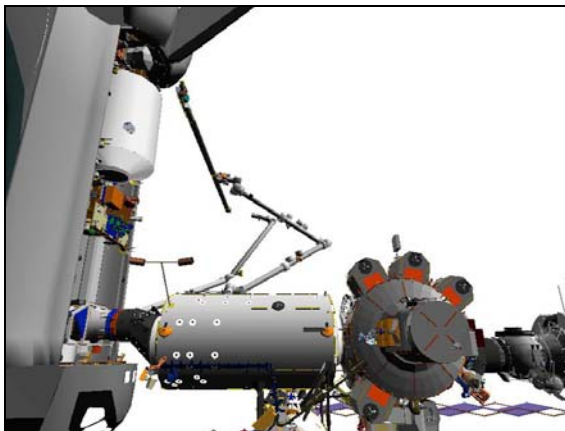

S1 LOWER OUTBOARD (90,20)

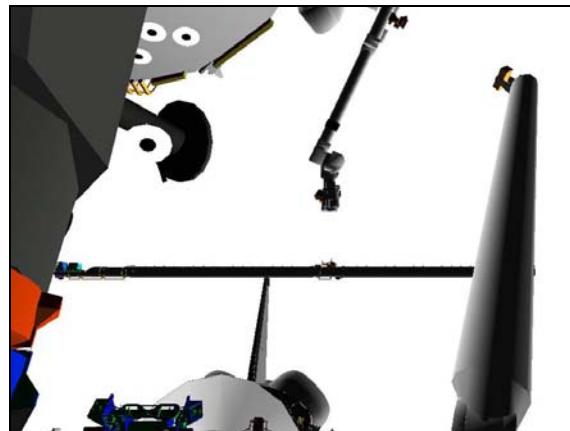

CCTV A (0,28)

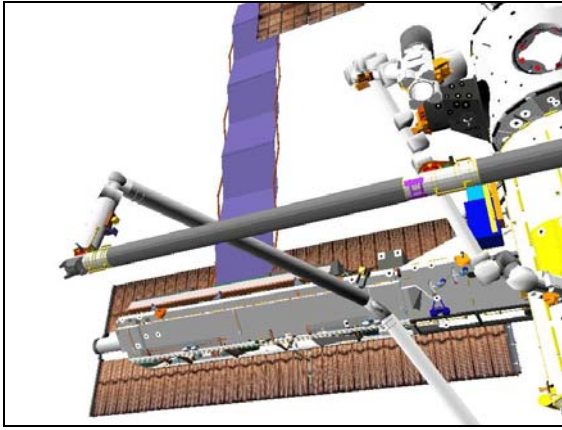

CCTV B (-25,30)



ELBOW (-30,0)

A7U

3. OBSS UNGRAPPLE

CCTV – config for ungrapple

- RMS WRIST, zoom 34.0 HFOV
- focus 5 ft

MON 1	B (Elbow)
MON 2	Wrist

On SSRMS Operator GO for Ungrapple

NOTE

CONTR ERR It and 'S96 PDRS CNTL' msg may occur due to Consistency/Envelope Check error

RATE – COARSE (RATE MIN tb-OFF)

SM 94 PDRS CONTROL

AUTO BRAKE INH – ITEM 10 EXEC (*)

BRAKES – OFF (tb-OFF)

MODE – TEST, ENTER

Wait 5 sec

BRAKES – ON (tb-ON)

SM 94 PDRS CONTROL

AUTO BRAKE ENA – ITEM 9 EXEC (*)

PL ID – ITEM 3 +0 EXEC

INIT ID – ITEM 24 +0 EXEC

RATE – VERN (RATE MIN tb-ON)

BRAKES – OFF (tb-OFF)

MODE – END EFF, ENTER

CAUTION

Monitor EE tb timing to prevent EE motor burnout

EE MODE – AUTO

RELEASE sw – depress (mom)

When OPEN tb – gray, slowly mnvr arm clear

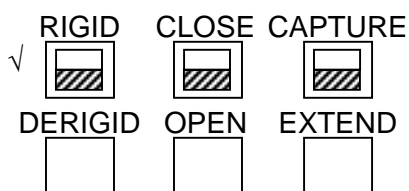

CRITICAL TIMES (28 sec total)

DERIGID tb – gray, 5 sec max, then
 OPEN tb – gray, 3 sec max, then
 EXTEND tb – gray, 20 sec max

EE MODE – OFF

- * If manual release reqd: *
- * EE MODE – MAN *
- * MAN CONTR – DERIGID (hold until DERIGID tb-gray, 5 sec max) *
- * RELEASE sw – depress (hold until OPEN tb-gray, 3 sec max) *
- * Mnvr arm clear, then *
- * EE MAN CONTR – DERIGID (hold until EXTEND tb-gray, 20 sec max) *
- * MODE – OFF *
- * BRAKES – ON (tb-ON) *

4. MNVR TO OBSS PRE-GRAPPLE

RATE – as desired (VERN within 10 ft)

MODE – as desired

Mnvr to OBSS PRE-GRAPPLE posn:

X	Y	Z	PITCH	YAW	ROLL	PL ID
-1015	-362	-688	284	360	270	0
SY	SP	EP	WP	WY	WR	
+23.5	+63.5	-29.6	-102.9	+11.5	-98.6	

BRAKES – ON (tb-ON)

√MODE – not DIRECT

JOINT sel – CRIT TEMP

Give SSRMS Operator GO to Berth OBSS

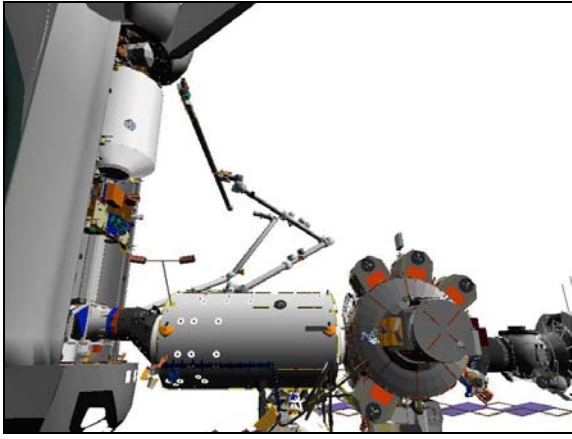

S1 LOWER OUTBOARD (90,20)

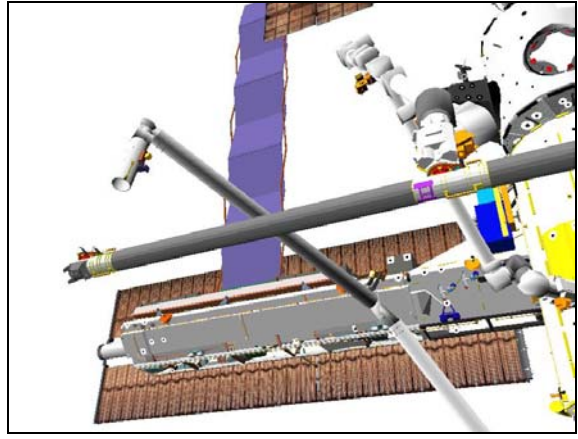

CCTV B (-25,30)



ELBOW (-20,-20)

This Page Intentionally Blank

TPS SURVEYS

(TBS)

TPS SURVEYS

This Page Intentionally Blank

OBSS CONTINGENCY

(TBS)

OBSS
CONTINGENCY

This Page Intentionally Blank

ORBITER REPAIR

ORM DTO (TBS)

ORBITER REPAIR MANEUVER (CONTINGENCY) FS 4-3

REVERSE ORBITER REPAIR MANEUVER (CONTINGENCY) FS 4-8

ORBITER
REPAIR

ORM DTO (TBS)

**ORBITER
REPAIR**

ORBITER REPAIR MANEUVER (CONTINGENCY)

1. SETUP

MON 1	Elbow (EE)
MON 2	CAM C

SM 94 PDRS CONTROL

- √PL ID, ITEM 3: 0
- √INIT ID, ITEM 24: 0

- A8U
- ## 2. MANEUVER TO PRE-GRAPPLE
- RATE – as desired (VERN within 10 ft)
 BRAKES – OFF (tb-OFF)
 MODE – as desired

Mnvr to PMA2 PRE-GRAPPLE posn:

X	Y	Z	PITCH	YAW	ROLL	PL ID
-724	-71	-562	214	330	291	0
SY	SP	EP	WP	WY	WR	
-33.9	+131.6	-141.8	-114.0	-41.0	-4.1	

- BRAKES – ON (tb-ON)
- √MODE – not DIRECT

3. ODS POWERUP

Perform DOCKING MECHANISM POWERUP (RNDZ, APDS)
 Perform UNDOCKING PREP (RNDZ, APDS)

4. RECAPTURE ODS INTERFACE

- A7L
- SM 167 DOCKING STATUS
 CLOSE LATCHES pb – push
 √LAT OP It – off
 √CL It – on
 APDS CIRC PROT OFF pb – push (It on)
 FIXER OFF pb – push (It on)

NOTE

APDS must be powered off within 10 sec of Capture to prevent the capture latches from automatically reopening

- RING OUT pb – push
- √FNL POS It – off

When CAPTURE It – on, immediately:

- PWR OFF pb – push
- ON pb – push
- √CAPTURE It – off
- √LAT CL It – on
- RING IN pb – push
- PWR ON pb – push

00:10

5. CONFIGURE ISS ATTITUDE CONTROL TBD

- 00:00 A7L 6. OPEN ODS HOOKS
 APDS CIRC PROT OFF pb – push (lt on)
 OPEN HOOKS pb – push
- 02:30 CRT √HOOKS 1,2 DRV CMD (two) – ON
- A7L √HOOKS 1,2 OP Its (two) – on

- 00:00 7. EXTEND RING
 RING OUT pb – push
 √FNL POS It – off
- CRT √DRV CMD – ON
 √FIXERS – ON
 √PETAL POS BASE (three) incr
- 03:40 A7L √RING INIT POS It – on
- CRT √PETAL POS BASE (three): 76 ± 3%
- 03:50 √CLUTCH – blank/SLIP
 When no relative motion [PETAL POS BASE (three) not changing for 60 sec], proceed with step 8

8. GRAPPLE PMA2

MON 1	EE (Elbow)
MON 2	CAM C

- A7U CCTV – config for grapple
 – install PDRS TARGET OVERLAY FOR CTVM
 – RMS WRIST, zoom 34.0 HFOV
 focus 5 ft

Maintain eyepoint ~18 in when using grapple overlay

- A8U RATE – VERN (RATE MIN tb-ON)
 BRAKES – OFF (tb-OFF)
 MODE – END EFF, ENTER

Mnvr to grapple envelope

CAUTION
 Monitor EE tb timing to prevent EE motor burnout

- EE MODE – AUTO
 CAPTURE sw – depress (mom)

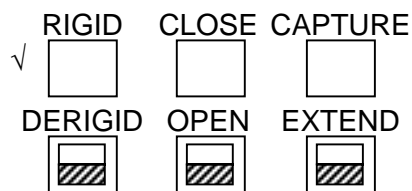

CRITICAL TIMES (28 sec total)
 CAPTURE tb – gray, then
 CLOSE tb – gray, 3 sec max, then
 RIGID tb – gray, 25 sec max

- EE MODE – OFF
 BRAKES – ON (tb-ON)

SM 94 PDRS CONTROL
 PL ID – ITEM 3 +4 EXEC
 INIT ID – ITEM 24 +4 EXEC

PMA2 GRAPPLE posn:

	X	Y	Z	PITCH	YAW	ROLL	PL ID
Expected	-649	0	-475	0	0	0	4
	SY	SP	EP	WP	WY	WR	
Expected	-61.0	+138.3	-151.5	-84.0	-51.0	+32.7	

Review GENERIC END EFFECTOR CUE CARD – ISS/SHUTTLE DOCKED OPS

- A7L 9. OPEN CAPTURE LATCHES
 OPEN LATCHES pb – push
 √LAT CL It – off
 √OP It – on
 PWR OFF pb – push

- A8U 10. MANEUVER TO UNDOCKED POSITION
 RATE – VERN (RATE MIN tb-ON)
 BRAKES – OFF (tb-OFF)
 MODE – ORB LD, ENTER

MON 1	CAM A
MON 2	CAM C

Mnvr to UNDOCKED posn:

X	Y	Z	PITCH	YAW	ROLL	PL ID
-648	-1	-671	0	0	0	4
SY	SP	EP	WP	WY	WR	
-74.6	+120.9	-105.1	-96.0	-49.7	+53.7	

- BRAKES – ON (tb-ON)
 √MODE – not DIRECT

11. CONFIGURE ISS ATTITUDE CONTROL
 TBD

12. AUTO SEQUENCE TO OVERNIGHT PARK POSITION

MON 1	CAM A
MON 2	CAM C

SM 94 PDRS CONTROL

PL ID – ITEM 3 +5 EXEC
 INIT ID – ITEM 24 +5 EXEC
 AUTO MODE 1 – ITEM 13 +1 EXEC

- A8U RATE – VERN (RATE MIN tb-ON)
 BRAKES – OFF (tb-OFF)
 MODE – AUTO 1, ENTER

SM 94 PDRS CONTROL

- √START PT, ITEM 17: 1
 √READY It – ON
 AUTO SEQ – PROCEED (IN PROG It on)

Auto Pos #	X/ SY	Y/ SP	Z/ EP	PITCH/ WP	YAW/ WY	ROLL/ WR	PL ID
1	-679	-42	-729	215	330	290	5
	-74.6	+120.9	-105.1	-96.0	-49.7	+53.7	
2	-783	15	-732	236	291	327	
	-55.6	+110.6	-103.8	-55.3	-37.5	+83.7	
3	-1082	-104	-722	324	293	66	
	-7.7	+65.3	-50.2	-66.0	-47.7	+69.5	
4	-1017	-394	-694	354	331	107	
	+36.0	+70.4	-46.3	-52.7	-58.4	+87.9	
5	-1003	-394	-637	347	356	124	
	+37.3	+80.5	-71.7	-25.7	-35.8	+115.0	
6	-605	-340	-548	318	23	193	
	+126.4	+112.5	-117.1	-78.5	-63.1	+92.9	
7	-364	-340	-489	280	10	257	
	+151.5	+69.4	-80.5	-73.4	-30.7	+126.6	
8	-375	-194	-589	215	338	284	
	+170.6	+96.7	-105.9	-31.7	+17.6	146.4	

- √READY It – ON
- BRAKES – ON (tb-ON)
- √MODE – not DIRECT
- PARAM – PORT TEMP
- JOINT – CRIT TEMP

- A7L
13. RECONFIGURE ODS
PWR ON pb – push
CLOSE LATCHES pb – push
√LAT OP It – off
√CL It – on

14. ODS POWERDOWN
Perform DOCKING MECHANISM POWERDOWN (RNDZ, APDS)

15. CONFIGURE ISS ATTITUDE CONTROL
TBD

16. ORBITER OVERNIGHT PARK CONFIGURATION
TBD

17. CONFIGURE ISS ATTITUDE CONTROL
TBD

18. AUTO SEQUENCE TO REPAIR POSITION

MON 1	CAM A
MON 2	CAM C

SM 94 PDRS CONTROL

- √PL ID, ITEM 3: 5
- √INIT ID, ITEM 24: 5
- √AUTO MODE 1, ITEM 13: 1

A8U RATE – VERN (RATE MIN tb-ON)
 BRAKES – OFF (tb-OFF)
 MODE – AUTO 1, ENTER

SM 94 PDRS CONTROL

START PT – ITEM 17 +8 EXEC

√READY It – ON
 AUTO SEQ – PROCEED (IN PROG It on)

Auto Pos #	X/ SY	Y/ SP	Z/ EP	PITCH/ WP	YAW/ WY	ROLL/ WR	PL ID
8	-375	-194	-589	215	338	284	5
	+170.6	+96.7	-105.9	-31.7	+17.6	146.4	
9	-158	-151	-381	206	345	273	
	+171.9	+31.0	-61.0	+0.1	+13.0	+134.6	
10	-158	-151	-248	248	345	273	
	+168.4	+3.5	-28.3	-44.2	+1.0	+130.9	
11	-340	-151	-109	279	345	273	
	+156.9	+5.2	-68.6	-32.9	-7.3	+133.0	
12	-498	-120	-97	315	315	287	
	+143.4	+2.7	-89.4	-47.7	+6.0	+140.8	
13	-852	-165	-158	341	330	290	
	+53.4	+16.3	-115.4	+32.4	-61.6	+237.4	

BRAKES – ON (tb-ON)
 √MODE – not DIRECT

19. CONFIGURE ISS ATTITUDE CONTROL
TBD
20. ORBITER REPAIR CONFIGURATION
TBD

REVERSE ORBITER REPAIR MANEUVER (CONTINGENCY)

1. SETUP

MON 1	Elbow
MON 2	CAM B

SM 94 PDRS CONTROL

- √PL ID, ITEM 3: 5
- √INIT ID, ITEM 24: 5

2. CONFIGURE ISS ATTITUDE CONTROL TBD

3. MANEUVER BACK TO REPAIR START POSITION

√REPAIR posn:

X	Y	Z	PITCH	YAW	ROLL	PL ID
-852	-165	-158	341	330	290	5
SY	SP	EP	WP	WY	WR	
+53.4	+16.3	-115.4	+32.4	-61.6	+237.4	

If not within 1"/1° of REPAIR posn:

Load OPR CMD (Items 18-23, 25)

-852, -165, -158, 341, 330, 290

A8U

√RATE – VERN (RATE MIN tb-ON)
BRAKES – OFF (tb-OFF)
MODE – OPR CMD, ENTER

√AUTO SEQ READY It – ON
– PRO

When AUTO SEQ IN PROG It – OFF:

BRAKES – ON
√MODE – not DIRECT

4. AUTO SEQUENCE TO OVERNIGHT PARK POSITION

SM 94 PDRS CONTROL

AUTO MODE 2 – ITEM 13 +2 EXEC

A8U

RATE – VERN (RATE MIN tb-ON)
BRAKES – OFF (tb-OFF)
MODE – AUTO 2, ENTER

SM 94 PDRS CONTROL

√START PT, ITEM 17: 1

√READY It – ON
 AUTO SEQ – PROCEED (IN PROG It on)

Auto Pos #	X/ SY	Y/ SP	Z/ EP	PITCH/ WP	YAW/ WY	ROLL/ WR	PL ID
1	-852	-165	-158	341	330	290	5
	+53.4	+16.3	-115.4	+32.4	-61.6	+237.4	
2	-498	-120	-97	315	315	287	
	+143.4	+2.7	-89.4	-47.7	+6.0	+140.8	
3	-340	-151	-109	279	345	273	
	+156.9	+5.2	-68.6	-32.9	-7.3	+133.0	
4	-158	-151	-248	248	345	273	
	+168.4	+3.5	-28.3	-44.2	+1.0	+130.9	
5	-158	-151	-381	206	345	273	
	+171.9	+31.0	-61.0	+0.1	+13.0	+134.6	
6	-375	-194	-589	215	338	284	
	+170.6	+96.7	-105.9	-31.7	+17.6	146.4	

√READY It – ON
 BRAKES – ON (tb-ON)
 √MODE – not DIRECT
 PARAM – PORT TEMP
 JOINT – CRIT TEMP

5. CONFIGURE ISS ATTITUDE CONTROL
TBD
6. ORBITER OVERNIGHT PARK CONFIGURATION
TBD
7. CONFIGURE ISS ATTITUDE CONTROL
TBD
8. AUTO SEQUENCE TO UNDOCKED POSITION

MON 1	Elbow
MON 2	CAM B

SM 94 PDRS CONTROL

√PL ID, ITEM 3: 5
 √INIT ID, ITEM 24: 5
 AUTO MODE 2, ITEM 13: 2

A8U RATE – VERN (RATE MIN tb-ON)
 BRAKES – OFF (tb-OFF)
 MODE – AUTO 2, ENTER

SM 94 PDRS CONTROL

START PT – ITEM 17 +6 EXEC

√READY It – ON
 AUTO SEQ – PROCEED (IN PROG It on)

Auto Pos #	X/ SY	Y/ SP	Z/ EP	PITCH/ WP	YAW/ WY	ROLL/ WR	PL ID
6	-375	-194	-589	215	338	284	5
	+170.6	+96.7	-105.9	-31.7	+17.6	146.4	
7	-364	-340	-489	280.0	10.1	257.4	
	+151.5	+69.4	-80.5	-73.4	-30.7	+126.6	
8	-605	-340	-548	318.1	23.0	193.4	
	+126.4	+112.5	-117.1	-78.5	-63.1	+92.9	
9	-1003	-394	-637	347.0	355.8	124.1	
	+37.3	+80.5	-71.7	-25.7	-35.8	+115.0	
10	-1017	-394	-694	353.7	331.4	107.4	
	+36.0	+70.4	-46.3	-52.7	-58.4	+87.9	
11	-1082	-104	-722	324.5	293.2	66.0	
	-7.7	+65.3	-50.2	-66.0	-47.7	+69.5	
12	-783	15	-732	235.7	291.3	326.9	
	-55.6	+110.6	-103.8	-55.3	-37.5	+83.7	
13	-679	-42	-729	215.2	329.7	289.9	
	-74.6	+120.9	-105.1	-96.0	-49.7	+53.7	

BRAKES – ON (tb-ON)
√MODE – not DIRECT

9. ODS POWERUP
Perform DOCKING MECHANISM POWERUP (RNDZ, APDS)
10. CONFIGURE ISS ATTITUDE CONTROL
TBD
11. MANEUVER TO ODS CAPTURE POSITION
SM 94 PDRS CONTROL
PL ID – ITEM 3 +4 EXEC
INIT ID – ITEM 24 +4 EXEC

A8U RATE – VERN (RATE MIN tb-ON)
BRAKES – OFF (tb-OFF)
MODE – ORB LD, ENTER

MON 1	CAM A
MON 2	CAM C

Mnvr to CAPTURE posn:

X	Y	Z	PITCH	YAW	ROLL	PL ID
-649	0	-471	0	0	0	4
SY	SP	EP	WP	WY	WR	
-60.7	+138.3	-152.3	-83.8	-51.0	+32.0	

BRAKES – ON (tb-ON)
√MODE – not DIRECT

12. ODS CAPTURE
Perform DOCKING PREP (RNDZ, APDS)

After the PCT or equivalent has caused capture,
Perform DOCKING SEQUENCE CUE CARD (RNDZ), steps 1-3

13. RELEASE PMA2

MON 1	EE (Elbow)
MON 2	CAM C







A8U

RATE – VERN (RATE MIN tb-ON)
 BRAKES – OFF (tb-OFF)
 MODE – END EFF, ENTER

CAUTION
 Monitor EE tb timing to prevent EE motor burnout

EE MODE – AUTO
 RELEASE sw – depress (mom)

Mnvr clear of grapple pin

			<u>CRITICAL TIMES (28 sec total)</u>
√ 			DERIGID tb – gray, 5 sec max, then
DERIGID	OPEN	EXTEND	OPEN tb – gray, 3 sec max, then
			EXTEND tb – gray, 20 sec max

EE MODE – OFF

- * If manual release reqd: *
- * EE MODE – MAN *
- * MAN CONTR – DERIGID (hold until DERIGID tb-gray, 5 sec max) *
- * RELEASE sw – depress (hold until OPEN tb-gray, 3 sec max) *
- * Mnvr arm clear, then *
- * EE MAN CONTR – DERIGID (hold until EXTEND tb-gray, 20 sec max) *
- * MODE – OFF *
- * BRAKES – ON (tb-ON) *

BRAKES – ON (tb-ON)
 √MODE – not DIRECT

14. RETRACT RING AND CLOSE ODS HOOKS

Perform DOCKING SEQUENCE CUE CARD (RNDZ), starting in step 4

15. CONFIGURE ISS ATTITUDE CONTROL

TBD

16. MANEUVER TO PRE-CRADLE POSITION

SM 94 PDRS CONTROL

PL ID – ITEM 3 +0 EXEC
 INIT ID – ITEM 24 +0 EXEC

A8U

RATE – as desired (VERN within 10 ft)
 BRAKES – OFF (tb-OFF)
 MODE – as desired

Mnvr to PRE-CRADLE posn:

X	Y	Z	PITCH	YAW	ROLL	PL ID
-1261	-146	-551	5	2	0	0
SY	SP	EP	WP	WY	WR	
0	+25	-25	+5	0	0	

BRAKES – ON (tb-ON)

√MODE – not DIRECT

17. ODS POWERDOWN

Go to DOCKING MECHANISM POWERDOWN (RNDZ, APDS)

INSPECTION AND REPAIR REFERENCE DATA

OBSS JOINT ANGLES VS POR COORDINATES (TBS)
 AUTO SEQUENCES (TBS)
 COORDINATE SYSTEM – PL ID 1 (TBS)
 2 (TBS)
 3 (TBS)
 4 (TBS)

 GO/NO-GO CRITERIA (TBS)
 ATTITUDE CONTROL CONSTRAINTS (TBS)
SRMS EE CAM JOINT ANGLES VS POR COORDINATES (TBS)
 AUTO SEQUENCE (TBS)
 COORDINATE SYSTEM – PL ID 5 (TBS)
ORM JOINT ANGLES VS POR COORDINATES..... FS 5-3
 AUTO SEQUENCES..... FS 5-4
 COORDINATE SYSTEM – PL ID 4A (UPLINK) (TBS)
 5A (UPLINK) (TBS)

 GO/NO-GO CRITERIA (TBS)
 ATTITUDE CONTROL CONSTRAINTS (TBS)

INSPECT/REPAIR
REF DATA

This Page Intentionally Blank

ORM JOINT ANGLES VS POR COORDINATES

PMA2 PRE-GRAPPLE posn

X	Y	Z	PITCH	YAW	ROLL	PL ID
-724	-71	-562	214	330	291	0
-692	-30	-504	0	0	0	4
-724	-71	-562	214	330	291	5
SY	SP	EP	WP	WY	WR	
-33.9	+131.6	-141.8	-114.0	-41.0	-4.1	

PMA2 GRAPPLED posn (Expected Values)

X	Y	Z	PITCH	YAW	ROLL	PL ID
-681	-41	-533	214	330	290	0
-649	0	-475	0	0	0	4
-681	-41	-533	214	330	290	5
SY	SP	EP	WP	WY	WR	
-61.0	+138.3	-151.5	-84.0	-51.0	+32.7	

UNDOCKED posn

X	Y	Z	PITCH	YAW	ROLL	PL ID
-679	-42	-729	215	330	290	0
-648	-1	-671	1	0	0	4
-679	-42	-729	215	330	290	5
SY	SP	EP	WP	WY	WR	
-76.4	+120.9	-105.1	-96.0	-49.7	+53.7	

REPAIR posn

X	Y	Z	PITCH	YAW	ROLL	PL ID
-852	-165	-158	341	330	290	0
-917	-124	-167	127	0	0	4
-852	-165	-158	341	330	290	5
SY	SP	EP	WP	WY	WR	
+53.4	+16.3	-115.4	+32.4	-61.6	+237.4	

CAPTURE posn

X	Y	Z	PITCH	YAW	ROLL	PL ID
-681	-41	-529	214	330	290	0
-649	0	-471	0	0	0	4
-681	-41	-529	214	330	290	5
SY	SP	EP	WP	WY	WR	
-60.7	+138.3	-152.3	-83.8	-51.0	+32.0	

ORM AUTO SEQUENCES

Maneuver to Repair posn (PL ID 5)

Auto Seq ID	Auto posn	X/ SY	Y/ SP	Z/ EP	PITCH/ WP	YAW/ WY	ROLL/ WR	Pause
1	1	-679	-42	-729	215	330	290	
		-74.6	+120.9	-105.1	-96.0	-49.7	+53.7	
1	2	-783	15	-732	236	291	327	
		-55.6	+110.6	-103.8	-55.3	-37.5	+83.7	
1	3	-1082	-104	-722	324	293	66	
		-7.7	+65.3	-50.2	-66.0	-47.7	+69.5	
1	4	-1017	-394	-694	354	331	107	
		+36.0	+70.4	-46.3	-52.7	-58.4	+87.9	
1	5	-1003	-394	-637	347	356	124	
		+37.3	+80.5	-71.7	-25.7	-35.8	+115.0	
1	6	-605	-340	-548	318	23	193	
		+126.4	+112.5	-117.1	-78.5	-63.1	+92.9	
1	7	-364	-340	-489	280	10	257	
		+151.5	+69.4	-80.5	-73.4	-30.7	+126.6	
1	8	-375	-194	-589	215	338	284	P
		+170.6	+96.7	-105.9	-31.7	+17.6	+146.4	
1	9	-158	-151	-381	206	345	273	
		+171.9	+31.0	-61.0	+0.1	+13.0	+134.6	
1	10	-158	-151	-248	248	345	273	
		+168.4	+3.5	-28.3	-44.2	+1.0	+130.9	
1	11	-340	-151	-109	279	345	273	
		+156.9	+5.2	-68.6	-32.9	-7.3	+133.0	
1	12	-498	-120	-97	315	315	287	
		+143.4	+2.7	-89.4	-47.7	+6.0	+140.8	
1	13	-852	-165	-158	341	330	290	P
		+53.4	+16.3	-115.4	+32.4	-61.6	+237.4	

Maneuver to Undock posn (PL ID 5)

Auto Seq ID	Auto posn	X/ SY	Y/ SP	Z/ EP	PITCH/ WP	YAW/ WY	ROLL/ WR	Pause
2	1	-852	-165	-158	341	330	290	
		+53.4	+16.3	-115.4	+32.4	-61.6	+237.4	
2	2	-498	-120	-97	315	315	287	
		+143.4	+2.7	-89.4	-47.7	+6.0	+140.8	
2	3	-340	-151	-109	279	345	273	
		+156.9	+5.2	-68.6	-32.9	-7.3	+133.0	
2	4	-158	-151	-248	248	345	273	
		+168.4	+3.5	-28.3	-44.2	+1.0	+130.9	
2	5	-158	-151	-381	206	345	273	
		+171.9	+31.0	-61.0	+0.1	+13.0	+134.6	
2	6	-375	-194	-589	215	338	284	P
		+170.6	+96.7	-105.9	-31.7	+17.6	+146.4	
2	7	-364	-340	-489	280	10	257	
		+151.5	+69.4	-80.5	-73.4	-30.7	+126.6	
2	8	-605	-340	-548	318	23	193	
		+126.4	+112.5	-117.1	-78.5	-63.1	+92.9	
2	9	-1003	-394	-637	347	356	124	
		+37.3	+80.5	-71.7	-25.7	-35.8	+115.0	
2	10	-1017	-394	-694	354	331	107	
		+36.0	+70.4	-46.3	-52.7	-58.4	+87.9	
2	11	-1082	-104	-722	324	293	66	
		-7.7	+65.3	-50.2	-66.0	-47.7	+69.5	
2	12	-783	15	-732	236	291	327	
		-55.6	+110.6	-103.8	-55.3	-37.5	+83.7	
2	13	-679	-42	-729	215	330	290	P
		-74.6	+120.9	-105.1	-96.0	-49.7	+53.7	

This Page Intentionally Blank

NOMINAL MPLM INSTALL (CONTINGENCY)

NODE 1 NADIR ACBM INSPECTION (CONTINGENCY)	FS 6-2
MPLM GRAPPLE IN BAY (CONTINGENCY)	FS 6-3
ROEU DEMATE (CONTINGENCY)	FS 6-5
UNBERTH (CONTINGENCY)	FS 6-7
INSTALL (CONTINGENCY)	FS 6-11
UNGRAPPLE ON NODE NADIR (CONTINGENCY)	FS 6-16

**NOM MPLM
INSTALL (CONT)**

NODE 1 NADIR ACBM INSPECTION (CONTINGENCY)

- A7U 1. SETUP
CCTV – RMS WRIST

SM 94 PDRS CONTROL

- √PL ID, ITEM 3: 0
√INIT ID, ITEM 24: 0

2. MNVR TO ACBM INSPECTION POSN
RATE – as reqd (VERN within 10 ft)
BRAKES – OFF (tb-OFF)
MODE – as desired

NODE 1 NADIR ACBM posn:

X	Y	Z	PITCH	YAW	ROLL	PL ID
-791	0	-875	145	0	180	0
SY	SP	EP	WP	WY	WR	
-56.1	+86.1	-71.9	+104.7	-51.9	+168.3	

3. ACBM INSPECTION
Drive in END EFF as reqd to view entire interface

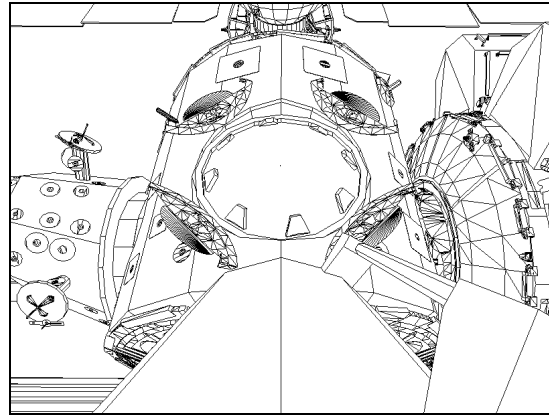
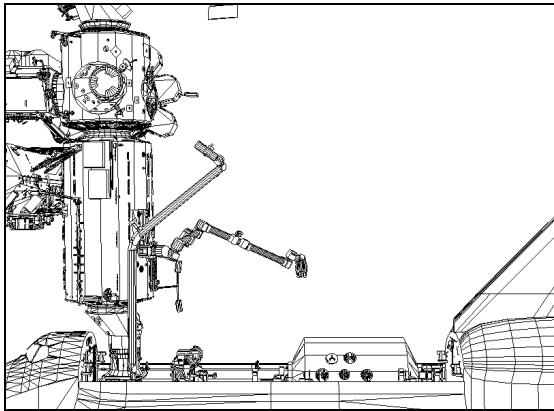

EE

BRAKES – ON (tb-ON)

MPLM GRAPPLE IN BAY (CONTINGENCY)

- A7U
- SETUP
 CCTV – config for grapple
 – install PDRS TARGET OVERLAY FOR CTVM
 – RMS WRIST, zoom 34.0 HFOV
 focus 5 ft
 Maintain eyepoint approx 18 in when using grapple overlay

SM 94 PDRS CONTROL

- √PL ID, ITEM 3: 0
 √INIT ID, ITEM 24: 0

- MNVR TO PRE-GRAPPLE

MON 1	A (B)
MON 2	Elbow (EE)

- RATE – as reqd (VERN within 10 ft)
 BRAKES – OFF (tb-OFF)
 MODE – ORB UNL, ENTER

NOTE

WR joint may be rotated 360 degrees to maintain consistency with documented joint angles through MPLM Install

PRE-GRAPPLE posn:

X	Y	Z	PITCH	YAW	ROLL	PL ID
-1059	-114	-497	271	310	151	0
SY	SP	EP	WP	WY	WR	
+2.6	+62.3	-85.3	-68.4	-30.6	-193.1	

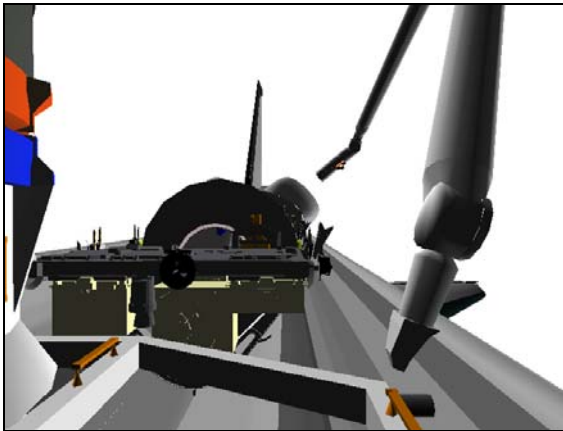

CCTV A (0,0)

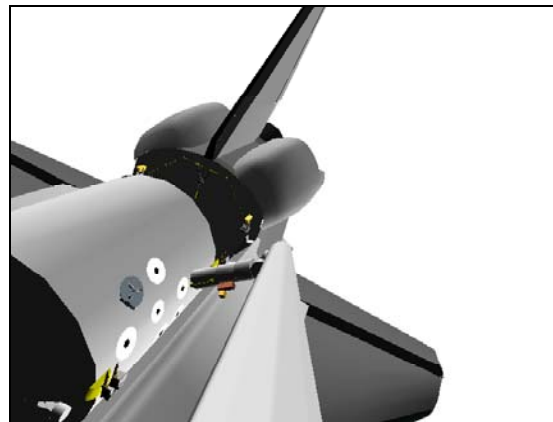

ELBOW (0,0)

- GRAPPLE

MON 1	EE (Elbow)
MON 2	A or Mux A/B (B)

- RATE – VERN (RATE MIN tb-ON)
 BRAKES – OFF (tb-OFF)
 MODE – END EFF, ENTER

Mnvr to grapple envelope

CAUTION
Monitor EE tb timing to prevent EE motor burnout

EE MODE – AUTO
CAPTURE sw – depress (mom)

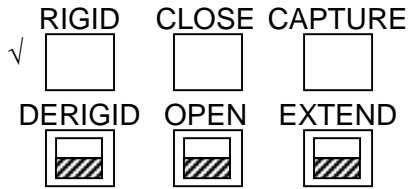

CRITICAL TIMES (28 sec total):
 CAPTURE tb – gray, then
 CLOSE tb – gray, 3 sec max, then
 RIGID tb – gray, 25 sec max

EE MODE – OFF
BRAKES – ON (tb-ON)

SM 94 PDRS CONTROL

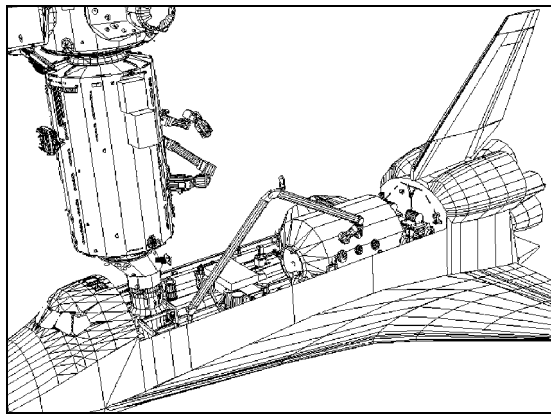
 PL ID – ITEM 3 +1(3) EXEC
 INIT ID – ITEM 24 +1(3) EXEC

Record POS/ATT and Joint Angles:

	X	Y	Z	PITCH	YAW	ROLL	PL ID
							1
							3
	SY	SP	EP	WP	WY	WR	
Expected	-2.0	+57.2	-89.4	-56.5	-30.6	-187.7	

Review GENERIC END EFFECTOR CUE CARD

Record POS/ATT and Joint Angles in MPLM BERTH (NOM MPLM BERTH (CONT)) and MPLM SJ BERTH (OFF-NOM MPLM BERTH (CONT))

MPLM ROEU DEMATE (CONTINGENCY)

- SSP 1
1. DEADFACE ROEU
 - √MPLM CHAN 1,2 HTR PWR – OFF (tb-bp)
 - √APCU 1,2 CONV – OFF (tb-bp)
 - √2 OUTPUT RLY – OP (tb-bp)

2. SETUP
CCTV – config for ROEU demate

MON 1	Tip Elbow
MON 2	Elbow (A)

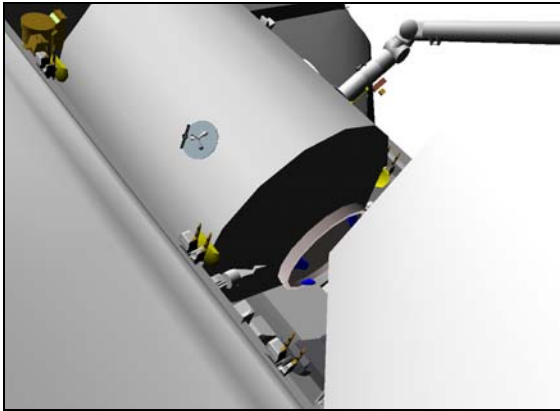

TIP ELBOW (85,-20)

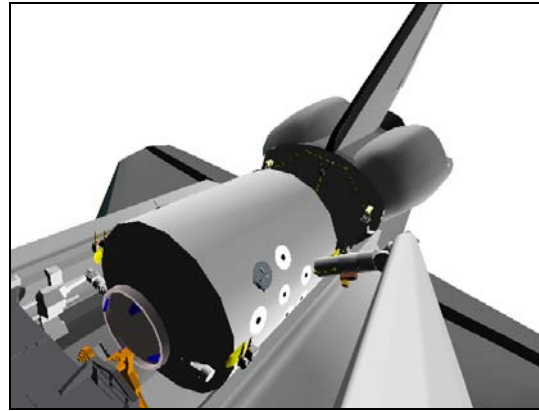

ELBOW (-20,0)

A6U Install ROEU A6U PANEL OVERLAY

PL RETEN PL SEL – 2

SM 97 PL RETENTION

√REL 2,3 (four) – 0

- * If LATCH 2,3 REL msw shows '1,' *
- * drive latch for single motor time *

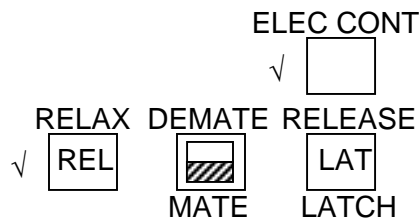

3. ACTIVATE ROEU
PL RETEN LOGIC PWR SYS 1,2 (two) – ON

R13L PL BAY MECH PWR SYS 1,2 (two) – ON

4. RELEASE LATCHES

Note single motor time (> 20 sec)

A6U

RELEASE/LATCH – REL (tb-REL), 40 sec max
– OFF

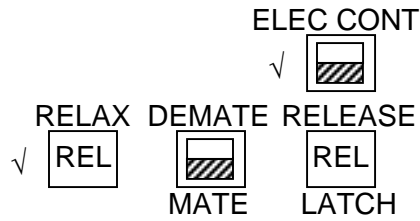

5. DEMATE ROEU

Note single motor time (> 18 sec)

DEMATE/MATE – DEMATE (tb-REL), 36 sec max
– OFF

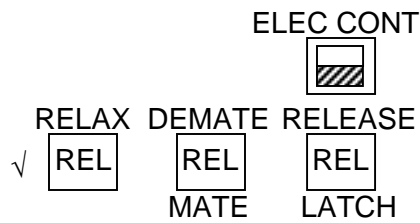

6. DEACTIVATE ROEU

PL RETEN LOGIC PWR SYS 1,2 (two) – OFF

R13L

PL BAY MECH PWR SYS 1,2 (two) – OFF

MPLM UNBERTH (CONTINGENCY)

1. SETUP

√MPLM ROEU DEMATE complete

A7U CCTV – config for unberth
 – Camr B,C,KEEL
 – install MPLM BERTH OVERLAY and mark any offset between keel target and overlay

MON 1	B/C Mux (D/A Mux)
MON 2	Keel (Elbow)

SSP 2 Activate KEEL CCTV:
 √cb SW PWR 3 (CB2) – cl
 MPLM KEEL CAM PWR – ON
 HTR/ILLUM PWR – OFF, then ON for HI
 (repeat for MED,LO,OFF)

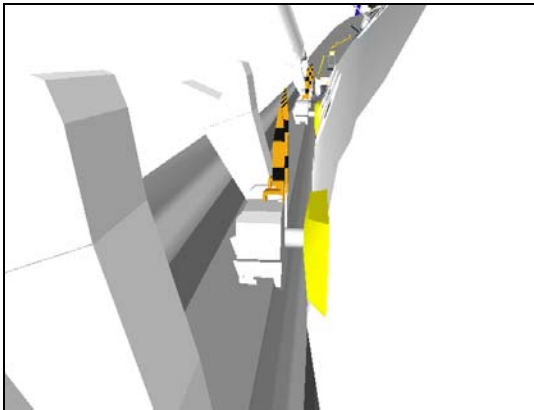

CCTV B (-5,-16)

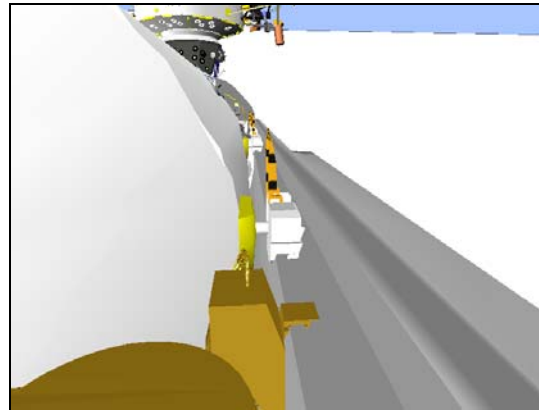

CCTV C (5,-16)

PCS MCS: MCS Configuration: US GNC Inhibits
US GNC Inhibits

cmd Desat Request Inhibit (Verify – Inh)

SM 94 PDRS CONTROL

√PL ID, ITEM 3: 1
 √INIT ID, ITEM 24: 1

2. ACTIVATE LATCHES

A6U √PL RETEN LAT (five) – OFF
 PL SEL – 1
 LOGIC PWR SYS 1,2 (two) – ON

R13L PL BAY MECH PWR SYS 1,2 (two) – ON

SM 97 PL RETENTION

√RDY-FOR-LAT 1,2,3,4,5 (ten): 1
 √LAT 1,2,3,4,5 (ten): 1

* If any REL msw shows '1', expect *
 * single motor time (60 sec) *

- A6U 3. AKA RELEASE
 √PL RETEN LAT 5 tb – LAT
 √RDY 5 tb – gray

Note single motor times (> 30 sec)
 PL RETEN LAT 5 – REL (tb-REL), 60 sec max
 – OFF

4. PRLA RELEASE
 √PL RETEN LAT 1,2,3,4 tb (four) – LAT
 √RDY 1,2,3,4 tb (four) – gray

Note single motor times (> 30 sec)
 PL RETEN LAT 1,2 (two) – REL (tb-REL), 60 sec max
 – OFF
 3,4 (two) – REL (tb-REL), 60 sec max
 – OFF

5. DEACTIVATE LATCHES
 PL RETEN LOGIC PWR SYS 1,2 (two) – OFF

R13L PL BAY MECH PWR SYS 1,2 (two) – OFF

Record POS/ATT and Joint Angles:

X	Y	Z	PITCH	YAW	ROLL	PL ID
						1
						3
SY	SP	EP	WP	WY	WR	

6. MNVR TO MPLM LOW HOVER
 RATE – as reqd (VERN within 10 ft)
 BRAKES – OFF (tb-OFF)
 MODE – ORB LD, ENTER

NOTE

Monitor clearance between MPLM and LMC

- A6U MnvR MPLM up until unconstrained
 √PL RETEN RDY 1,2,3,4 tb (four) – bp

MON 1	Keel (Elbow)
MON 2	A (D)

Mnvr MPLM to Low Hover

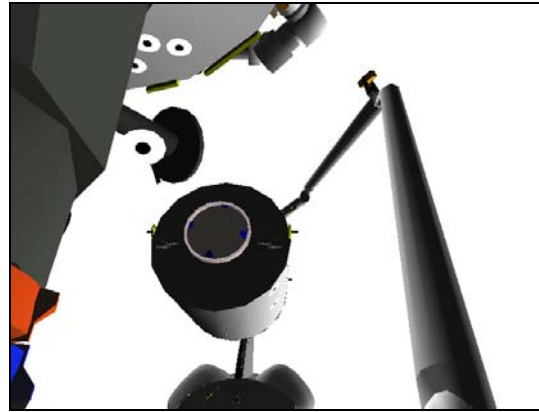
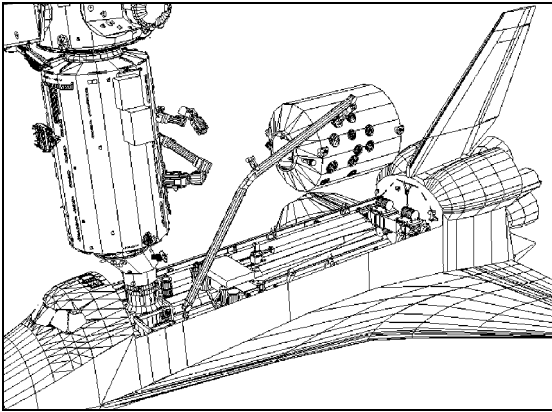

CCTV A (0,30)

MPLM LOW HOVER posn:

X	Y	Z	PITCH	YAW	ROLL	PL ID
-1106	0	-650	0	0	0	1
-992	0	-636	0	0	270	2
SY	SP	EP	WP	WY	WR	
-13.6	+63.4	-51.0	-94.3	-29.6	-174.3	

SSP 2

Deactivate KEEL CCTV:

MPLM KEEL CAM HTR/ILLUM PWR – toggle until illuminator off
(leave sw in ON posn)

PWR – OFF

BRAKES – ON (tb-ON)

7. MNVR TO MPLM HIGH HOVER

SM 94 PDRS CONTROL

PL ID – ITEM 3 +2 EXEC

INIT ID – ITEM 24 +2 EXEC

MON 1	Elbow (B)
MON 2	A → B (CBCS)

RATE – as reqd (VERN within 10 ft)

√BRAKES – OFF (tb-OFF)

MODE – ORB LD, ENTER

Mnvr MPLM to High Hover

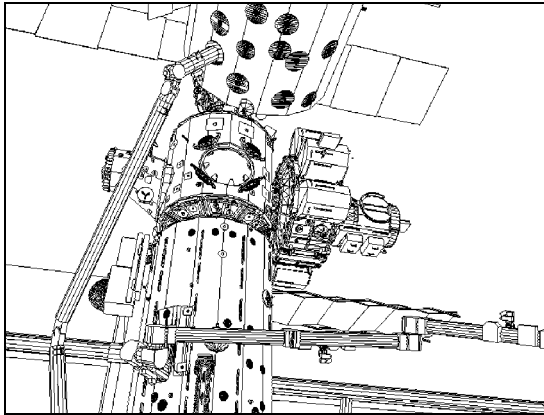

CCTV B (5,40)

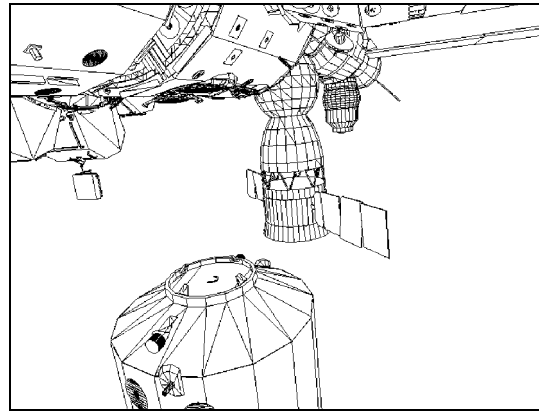

ELBOW (0,35)

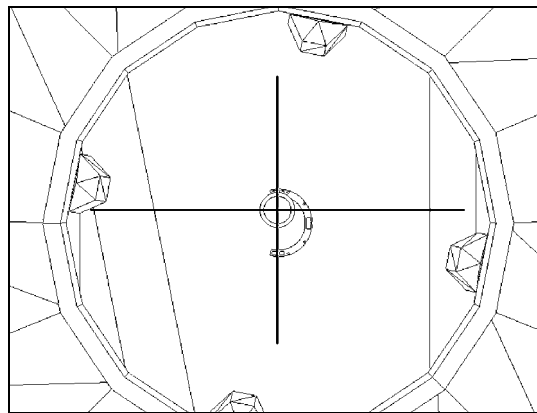

CBCS

MPLM to HIGH HOVER posn:

X	Y	Z	PITCH	YAW	ROLL	PL ID
-796	0	-980	1	0	0	2
SY	SP	EP	WP	WY	WR	
-40.0	+94.9	-67.7	+15.6	-41.7	-69.2	

BRAKES – ON (tb-ON)

√MODE – not DIRECT

MPLM INSTALL (CONTINGENCY)

1. MNVR TO MPLM PRE-INSTALL POSN

Install MPLM CBCS CCTV OVERLAY

√CBCS setup complete

SM 94 PDRS CONTROL

√PL ID, ITEM 3: 2

√INIT ID, ITEM 24: 2

MON 1	CBCS (B or C)
MON 2	Elbow/Dig Mux (A)

RATE – as reqd (VERN within 10 ft)

BRAKES – OFF (tb-OFF)

MODE – ORB LD, ENTER

MPLM PRE-INSTALL posn:

X	Y	Z	PITCH	YAW	ROLL	PL ID
-744	0	-980	1	0	0	2
SY	SP	EP	WP	WY	WR	
-49.5	+103.0	-74.3	+9.5	-34.6	-77.0	

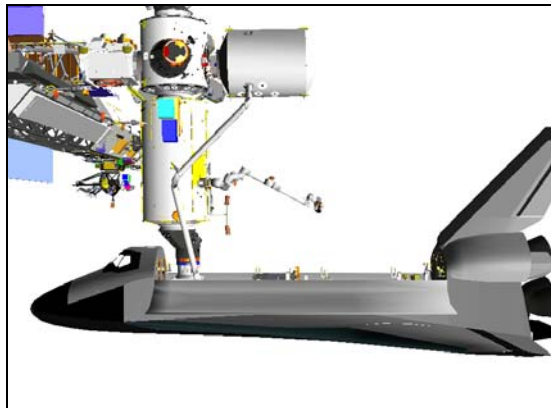

BRAKES – ON (tb-ON)

√MODE – not DIRECT

2. SETUP FOR INSTALLATION

A7U

CCTV – config for install

– RMS ELBOW, CBCS

√1.505 NODE 1 CBM VERIFY PRE-MATE STATUS (SODF: S&M:
NOMINAL: CBM) complete

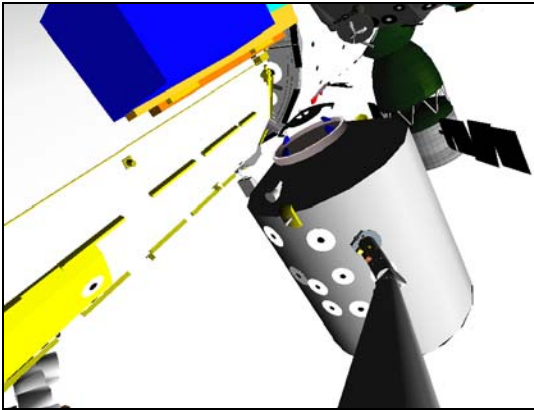

ELBOW (-18,7)

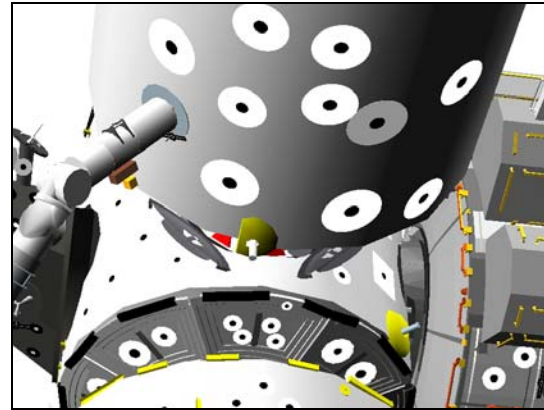

CCTV B (9,41)

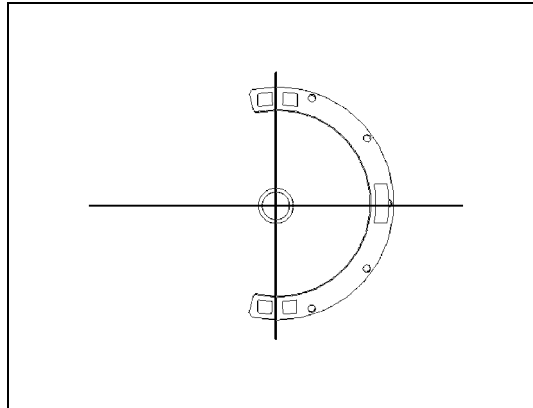

CBCS

3. UPDATE RMS COMMAND FRAME

SM 94 PDRS CONTROL

√POR DISPLAY, ITEM 30: ORB

Load POR REF with calculated POR data from the table below (SM 94, ITEMS 18-23, 25, 30)

SM 169 POS/ATT (PL ID 2)		SM 94 ITEM ENTRIES	
X	-		18
Y	-		19
Z	-		20
PITCH	-		21
YAW	-		22
ROLL	-		23

SM 94 PDRS CONTROL

POR DISPLAY – ITEM 30 EXEC (REL)

PCS

4. MNVR TO MPLM READY-TO-LATCH POSN

MCS: MCS Configuration: US GNC Inhibits

US GNC Inhibits

√Desat Request – Inh

MON 1	CBCS (B or C)
MON 2	Elbow (A)

RATE – VERN (RATE MIN tb-ON)

BRAKES – OFF (tb-OFF)

MODE – ORB LD, ENTER

SM 94 PDRS CONTROL

FLY-PL – ITEM 33 EXEC (*)

Mnvr MPLM until Y, Z, PITCH, YAW, ROLL errors ≤ 0.1

Mnvr MPLM until RTLs achieved (expected X: -4.8)

NOTE

√CBCS misalignment at X = -14 and correct if necessary

Expected MPLM READY-TO-LATCH posn:

X	Y	Z	PITCH	YAW	ROLL	
-713	1	-980	1	0	0	PL ID 2
-4.8	0	0	0	0	0	CMD FRAME
SY	SP	EP	WP	WY	WR	
-56.9	+106.8	-77.1	+5.7	-28.6	-82.2	

* Repeat step 4, correcting for misalignments until at *

* least 3 of 4 RTLs indicated *

NODE 1 NADIR CBM RTL CONFIG FOR MPLM

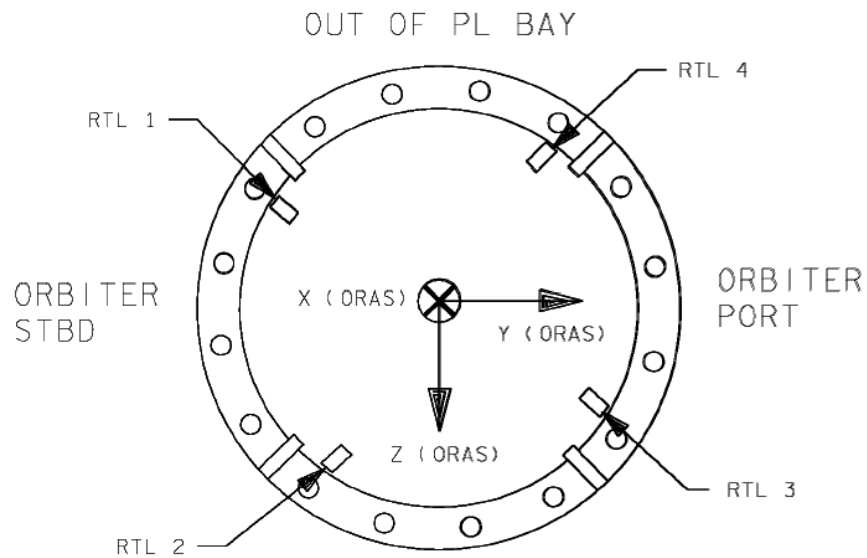

NOTE: VIEW SHOWN IS FROM NODE 1 NADIR WINDOW

4. FIRST STAGE CAPTURE

√1.506 NODE 1 CBM CAPTURE/ABOLT, step 2 (SODF: S&M: NOMINAL: CBM) complete

NOTE

CNTL ERR It and S96 PDRS CNTL msg may occur when Auto Brakes inhibited and during CBM Second Stage Capture

SM 94 PDRS CONTROL

AUTO BRAKE INH – ITEM 10 EXEC (*)

MODE – TEST, ENTER (CNTL ERR It and S96 PDRS CNTL msg may occur)

RATE – COARSE (RATE MIN tb-OFF)

6. SECOND STAGE CAPTURE

√1.506 NODE 1 CBM CAPTURE/ABOLT, step 3 (SODF: S&M: NOMINAL: CBM) complete

√1.506 NODE 1 CBM CAPTURE/ABOLT, step 2 (SODF: S&M: NOMINAL: CBM) complete

AUTO BRAKE ENA – ITEM 9 EXEC (*)

BRAKES – ON (tb-ON)

RATE – VERN (RATE MIN tb-ON)

After MPLM fully installed, record POS/ATT and Joint Angles:

	X	Y	Z	PITCH	YAW	ROLL	PL ID
							2
	SY	SP	EP	WP	WY	WR	
Actual							
Expected	-58.2	+107.3	-77.3	+5.0	-27.5	-83.0	

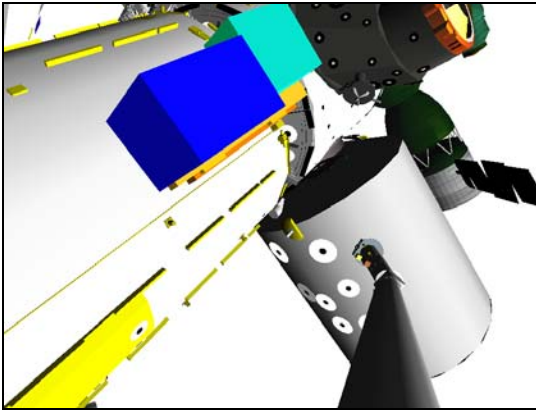

ELBOW (-18,7)

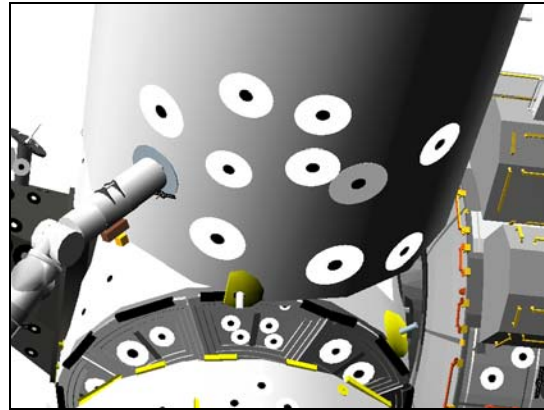

CCTV B (9,41)

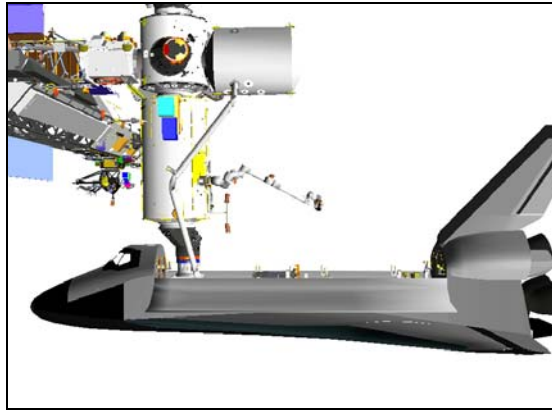

MPLM UNGRAPPLE ON NODE NADIR (CONTINGENCY)

1. SETUP

√1.506 NODE 1 CBM CAPTURE/ABOLT, step 4 (SODF: S&M: NOMINAL: CBM) complete

PCS MCS: MCS Configuration: US GNC Inhibits
US GNC Inhibits

cmd Desat Request Enable (Verify - Ena)

A7U CCTV – config for ungrapple
 – RMS WRIST, zoom 34.0 HFOV
 focus 5 ft

SM 94 PDRS CONTROL

PL ID – ITEM 3 +Q EXEC
 INIT ID – ITEM 24 +Q EXEC

2. MPLM UNGRAPPLE

MON 1	EE (Elbow)
MON 2	B (C)

RATE – VERN (RATE MIN tb-ON) within 10 ft
 BRAKES – OFF (tb-OFF)
 MODE – END EFF, ENTER

CAUTION
 Monitor EE tb timing to prevent EE motor burnout

When OPEN tb – gray,
 mnvr arm clear of GF and MPLM

EE MODE – AUTO
 RELEASE sw – depress (mom)

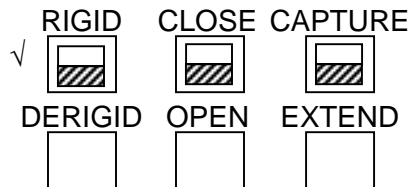

CRITICAL TIMES (28 sec total):
 DERIGID tb – gray, 5 sec max, then
 OPEN tb – gray, 3 sec max, then
 EXTEND tb – gray, 20 sec max

EE MODE – OFF
 BRAKES – ON (tb-ON)
 √MODE – not DIRECT
 JOINT – CRIT TEMP

- | | |
|---|---|
| * If manual release reqd: | * |
| * EE MODE – MAN | * |
| * MAN CONTR – DERIGID (hold until DERIGID | * |
| tb-gray, 5 sec max) | * |
| * RELEASE sw – depress (hold until OPEN | * |
| tb-gray, 3 sec max) | * |
| * Mnvr arm clear, then | * |
| * EE MAN CONTR – DERIGID (hold until EXTEND | * |
| tb-gray, 20 sec max) | * |
| * MODE – OFF | * |
| * BRAKES – ON | * |

NOMINAL MPLM BERTH (CONTINGENCY)

MPLM GRAPPLE ON NODE NADIR (CONTINGENCY).....	FS 7-2
UNINSTALL (CONTINGENCY).....	FS 7-4
BERTH (CONTINGENCY)	FS 7-6
ROEU MATE (CONTINGENCY)	FS 7-8
UNGRAPPLE IN BAY (CONTINGENCY).....	FS 7-10

**NOM MPLM
BERTH (CONT)**

MPLM GRAPPLE ON NODE NADIR (CONTINGENCY)

- A7U 1. SETUP
 CCTV – config for grapple
 – install PDRS TARGET OVERLAY FOR CTVM
 – RMS WRIST, zoom 34.0 HFOV
 focus 5 ft
 Maintain eyepoint approx 18 in when using grapple overlay

SM 94 PDRS CONTROL

- √ PL ID, ITEM 3: 0
- √ INIT ID, ITEM 24: 0

2. MNVR TO PRE-GRAPPLE

MON 1	Elbow (Tip Elbow)
MON 2	B (C)

- RATE – as reqd (VERN within 10 ft)
- BRAKES – OFF (tb-OFF)
- MODE – ORB UNL, ENTER

PRE-GRAPPLE posn:

X	Y	Z	PITCH	YAW	ROLL	PL ID
-777	-95	-867	91	320	331	0
SY	SP	EP	WP	WY	WR	
-47.0	+118.9	-92.0	+12.3	-36.5	-75.0	

3. GRAPPLE

MON 1	EE (Elbow)
MON 2	C (B)

- RATE – VERN (RATE MIN tb-ON)
- BRAKES – OFF (tb-OFF)
- MODE – END EFF, ENTER

Mnvr to grapple envelope

CAUTION
 Monitor EE tb timing to prevent EE motor burnout

EE MODE – AUTO
 CAPTURE sw – depress (mom)

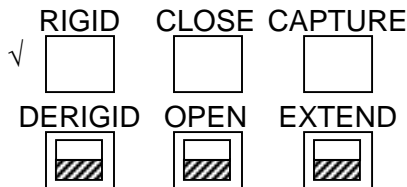

CRITICAL TIMES (28 sec total):
 CAPTURE tb – gray, then
 CLOSE tb – gray, 3 sec max, then
 RIGID tb – gray, 25 sec max

- EE MODE – OFF
- BRAKES – ON (tb-ON)
- √ MODE – not DIRECT

SM 94 PDRS CONTROL

- PL ID – ITEM 3 +2 EXEC
- INIT ID – ITEM 24 +2 EXEC

NOM MPLM BERTH (CONT)

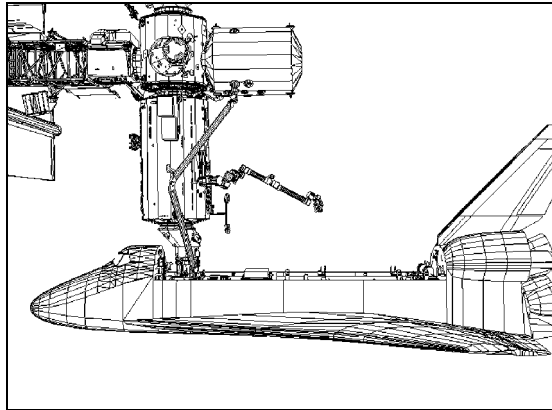

Record POS/ATT and Joint Angles:

X	Y	Z	PITCH	YAW	ROLL	PL ID
SY	SP	EP	WP	WY	WR	
-58.2	+107.3	-77.3	+5.0	-27.5	-83.0	

Expected

Review GENERIC END EFFECTOR CUE CARD

MPLM UNINSTALL (CONTINGENCY)

1. SETUP

√1.509 NODE 1 CBM DEMATE, step 9 (SODF: S&M: NOMINAL: CBM) complete

CCTV – config for uninstall

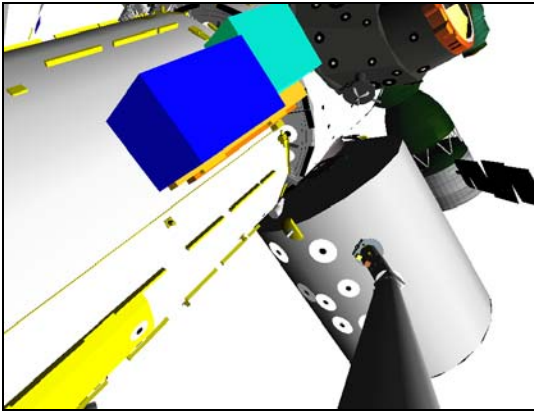

ELBOW (-18,7)

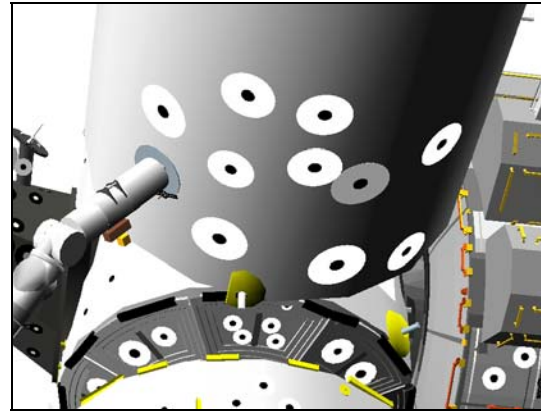

CCTV B (5,40)

PCS

MCS: MCS Configuration: US GNC Inhibits

US GNC Inhibits

√Desat Request – Inh

SM 94 PDRS CONTROL

√PL ID, ITEM 3: 2

√INIT ID, ITEM 24: 2

2. MNVR TO MPLM PRE-INSTALL

MON 1	CBCS (B or C)
MON 2	Elbow (A)

RATE – VERN (RATE MIN tb-ON)

BRAKES – OFF (tb-OFF)

MODE – ORB LD, ENTER

Mnvr MPLM to PRE-INSTALL posn:

X	Y	Z	PITCH	YAW	ROLL	PL ID
-744	0	-980	1	0	0	2
SY	SP	EP	WP	WY	WR	
-49.5	+103.0	-74.3	+9.5	-34.6	-77.0	

3. MNVR TO MPLM LOW HOVER POSN

MON 1	Elbow (B)
MON 2	B → A (C)

RATE – as reqd (VERN within 10 ft)
 ✓BRAKES – OFF (tb-OFF)
 MODE – ORB LD, ENTER

Mnvr to Low Hover

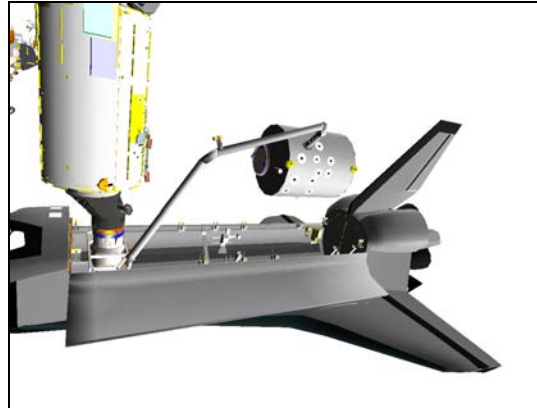

P1 OUTBOARD NADIR CAMR

MPLM LOW HOVER posn:

X	Y	Z	PITCH	YAW	ROLL	PL ID
-1106	0	-650	0	0	0	1
-992	0	-636	0	0	270	2
-1126	-3	-549	90	0	0	3
SY	SP	EP	WP	WY	WR	
-13.6	+63.4	-51.0	-94.3	-29.6	-174.3	

MPLM BERTH (CONTINGENCY)

1. SETUP
 A7U CCTV – config for berthing
 – install MPLM BERTH OVERLAY

SSP 2 Activate KEEL CCTV:
 √cb SW PWR 3 (CB2) – cl
 MPLM KEEL CAM PWR – ON
 HTR/ILLUM PWR – OFF, then ON for HI
 (repeat for MED,LO,OFF)

PCS MCS: MCS Configuration: US GNC Inhibits
US GNC Inhibits

√Desat Request – Inh

SM 94 PDRS CONTROL
 PL ID – ITEM 3 +1(3) EXEC
 INIT ID – ITEM 24 +1(3) EXEC

2. MNVR MPLM TO LATCHES

MON 1	Keel (Tip LEE)
MON 2	A → B/C Mux (D/A Mux)

RATE – VERN (RATE MIN tb-ON)
 BRAKES – OFF (tb-OFF)
 MODE – ORB LD, ENTER

NOTE

Monitor clearance between MPLM and LMC

A6U √PL RETEN PL SEL – 1
 √RDY 1,2,3,4,5 tb (five) – bp

Mnvr MPLM to Berthed posn (Insert PL ID 1 and 3 data from MPLM GRAPPLE IN BAY)

X	Y	Z	PITCH	YAW	ROLL	PL ID
						1
						3
SY	SP	EP	WP	WY	WR	

NOTE

Wait until PRLAs latched before applying brakes

A6U When vertical translation complete,
 √PL RETEN PL SEL – 1
 √RDY 1,2,3,4 tb (four) – gray
 √LAT 1,2,3,4 tb (four) – REL

SM 97 PL RETENTION

√RDY-FOR-LAT 1,2,3,4 (eight): 1

√LAT 1,2,3,4,5 (ten): 0

- * If any LAT msw shows '1', expect *
- * single motor time (60 sec) *

3. ACTIVATE LATCHES

PL RETEN LOGIC PWR SYS 1,2 (two) – ON

R13L PL BAY MECH PWR SYS 1,2 (two) – ON

4. AKA LATCH

A6U √PL RETEN LAT 5 tb – REL

Note single motor times (> 30 sec)
PL RETEN LAT 5 – LAT (tb-LAT), 60 sec max
– OFF
√RDY 5 tb – gray

5. PRLA LATCH

√PL RETEN LAT 1,2,3,4 tb (four) – REL
√RDY 1,2,3,4 tb (four) – gray

Note single motor times (> 30 sec)
PL RETEN LAT 1,2 (two) – LAT (tb-LAT), 60 sec max
– OFF
3,4 (two) – LAT (tb-LAT), 60 sec max
– OFF

6. DEACTIVATE LATCHES

PL RETEN LOGIC PWR SYS 1,2 (two) – OFF

R13L PL BAY MECH PWR SYS 1,2 (two) – OFF

BRAKES – ON (tb-ON)
√MODE – not DIRECT

PCS MCS: MCS Configuration: US GNC Inhibits
US GNC Inhibits

cmd Desat Request Enable (Verify - Ena)

SSP 2 Deactivate KEEL CCTV:
MPLM KEEL CAM HTR/ILLUM PWR – Toggle until illuminator OFF
(leave sw in ON posn)
PWR – OFF

MPLM ROEU MATE (CONTINGENCY)

1. SETUP

A6U CCTV – config for ROEU mate
Install ROEU A6U PANEL OVERLAY

MON 1	Elbow
MON 2	D

PL RETEN PL SEL – 2

SM 97 PL RETENTION

√LAT 1,2,3 (six): 0

- * If LATCH 2,3 LAT msw shows '1,' drive *
- * latch for single motor time *

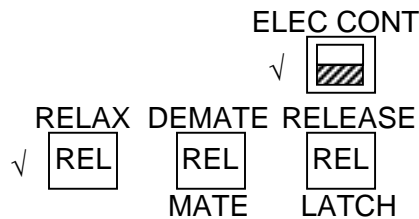

2. ACTIVATE ROEU

A6U PL RETEN LOGIC PWR SYS 1,2 (two) – ON

R13L PL BAY MECH PWR SYS 1,2 (two) – ON

3. MATE ROEU

A6U Note single motor time (> 30 sec)
DEMATE/MATE – MATE (tb-LAT), 60 sec max
– OFF

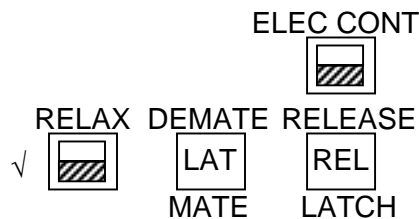

4. LATCH LATCHES

Note single motor time (> 20 sec)
RELEASE/LATCH – LATCH (tb-LAT), 40 sec max
– OFF

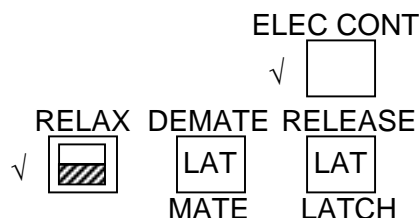

5. RELAX ROEU

NOTE

Monitor PL SEL 2 LATCH 1 REL SYS msws on SPEC 97

Note single motor time (> 12 sec)

RELAX – RELAX (tb-REL), 24 sec max

When LATCH 1 REL A(B) msw changes to 1:

RELAX – OFF

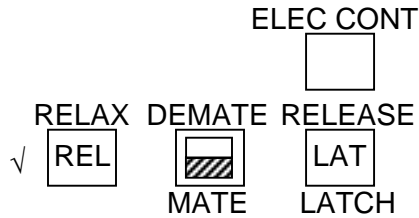

6. DEACTIVATE ROEU

A6U

PL RETEN LOGIC PWR SYS 1,2 (two) – OFF

PL SEL – MON

R13L

PL BAY MECH PWR SYS 1,2 (two) – OFF

MPLM UNGRAPPLE IN BAY (CONTINGENCY)

- A7U 1. SETUP
 CCTV – config for ungrapple
 – RMS WRIST, zoom 34.0 HFOV
 focus 5ft

SM 94 PDRS CONTROL
 PL ID – ITEM 3 +0 EXEC
 INIT ID – ITEM 24 +0 EXEC

2. MPLM UNGRAPPLE

MON 1	EE (Elbow)
MON 2	A, Mux A/B (B)

RATE – VERN (RATE MIN tb-ON) within 10 ft
 BRAKES – OFF (tb-OFF)
 MODE – END EFF, ENTER

CAUTION
 Monitor EE tb timing to prevent EE motor burnout

When OPEN tb – gray,
 mnvr arm clear of GF and MPLM

EE MODE – AUTO
 RELEASE sw – depress (mom)

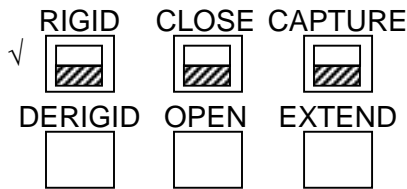

CRITICAL TIMES (28 sec total):
 DERIGID tb – gray, 5 sec max, then
 OPEN tb – gray, 3 sec max, then
 EXTEND tb – gray, 20 sec max

EE MODE – OFF

BRAKES – ON (tb-ON)
 ✓MODE – not DIRECT
 JOINT – CRIT TEMP

- * If manual release reqd: *
- * EE MODE – MAN *
- * MAN CONTR – DERIGID (hold until DERIGID *
- * tb-gray, 5 sec max) *
- * RELEASE sw – depress (hold until OPEN *
- * tb-gray, 3 sec max) *
- * Mnvr arm clear, then *
- * EE MAN CONTR – DERIGID (hold until EXTEND *
- * tb-gray, 20 sec max) *
- * MODE – OFF *
- * BRAKES – ON *

OFF-NOMINAL MPLM INSTALL (CONTINGENCY)

MPLM SJ GRAPPLE IN BAY (CONTINGENCY)	FS 8-2
UNBERTH (CONTINGENCY)	FS 8-9
INSTALL (CONTINGENCY)	FS 8-14
UNGRAPPLE ON NODE NADIR (CONTINGENCY).....	FS 8-22
JETTISON (CONTINGENCY).....	FS 8-24

OFF-NOM MPLM
INSTALL (CONT)

MPLM SJ GRAPPLE IN BAY (CONTINGENCY)

- A7U
- SETUP
 CCTV – config for grapple
 – install PDRS TARGET OVERLAY FOR CTVM
 – RMS WRIST, zoom 34.0 HFOV
 focus 5 ft
 – reset PAN/TILT values for CCTV A, B, C, and D
 – fully zoom out for SJ pictures
 Maintain eyepoint approx 18 in when using grapple overlay

SM 94 PDRS CONTROL

- √ PL ID, ITEM 3: 0
- √ INIT ID, ITEM 24: 0

- SJ MNVR TO PRE-GRAPPLE
 RATE – as reqd (VERN within 10 ft)
 BRAKES – OFF (tb-OFF)
 MODE – best available

NOTE

Monitor clearance between SRMS and SSRMS

Mnvr as follows (reference pictures as reqd):

	SY	SP	EP	WP	WY	WR	
Pre-Cradle	0.0	+25.0	-25.0	+5.0	0.0	0.0	
1	+2.6						
2		+62.3					
3			-85.3				
4				-68.4			
5					-30.6		
6						-193.1	
Pre-Grapple	+2.6	+62.3	-85.3	-68.4	-30.6	-193.1	
	X	Y	Z	PITCH	YAW	ROLL	PL ID
	-1060	-114	-497	271	310	151	0

- BRAKES – ON (tb-ON)
- MODE – not DIRECT

OFF-NOM MPLM
INSTALL (CONT)

Step 1:

Drive SY+ (for 2.6°)
From 0.0 to +2.6

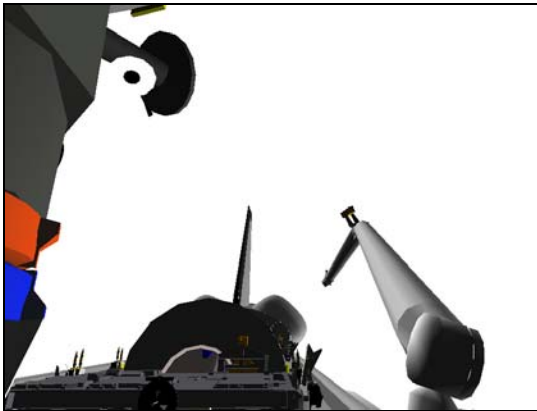

CCTV A (0,20)

Step 2:

Drive SP+ (for 37.3°)
From +25.0 to +62.3

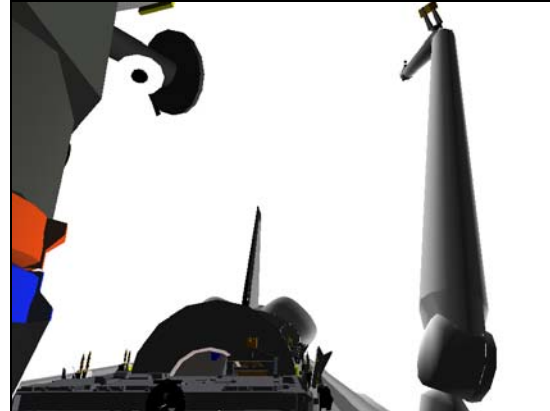

CCTV A (0,20)

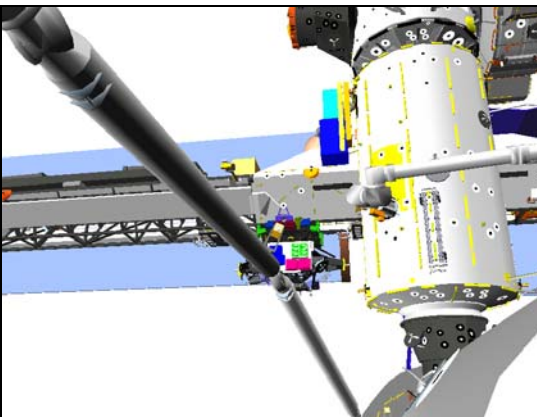

CCTV B (-10,20)

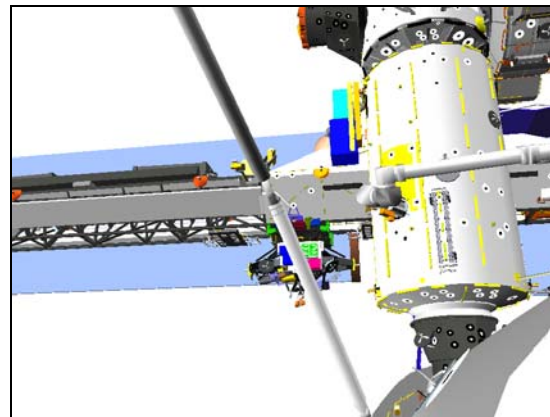

CCTV B (-10,20)



CCTV D (2,23)



CCTV D (2,23)

Step 3:

Drive EP- (for 60.3°)
From -25.0 to -85.3

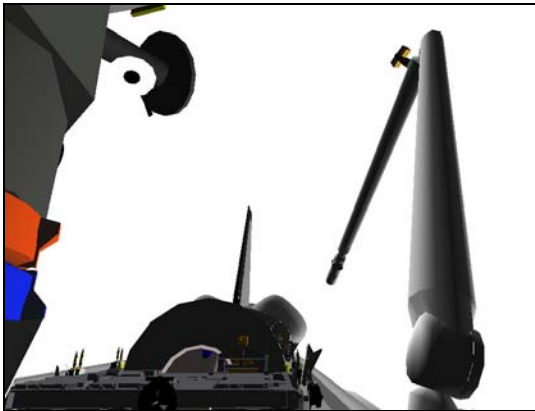

CCTV A (0,20)

Step 4:

Drive WP- (for 73.4°)
From +5.0 to -68.4



CCTV A (0,20)

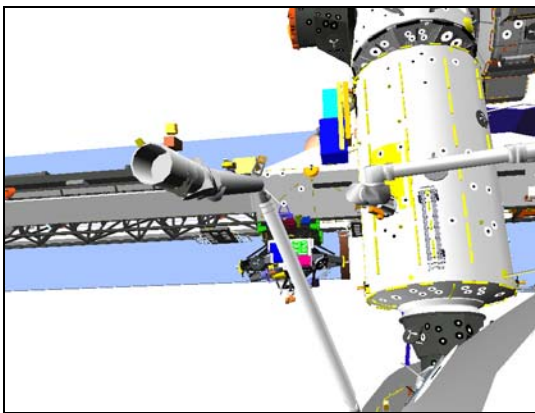

CCTV B (-10,20)

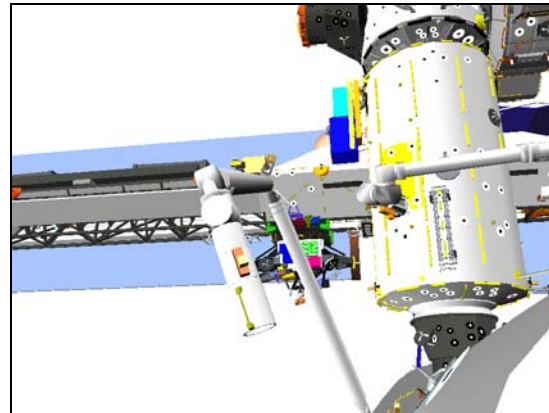

CCTV B (-10,20)

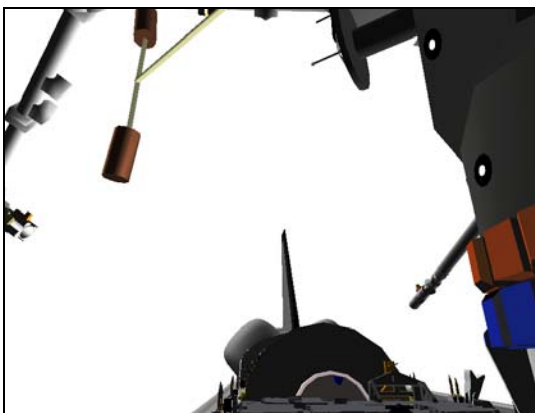

CCTV D (2,23)

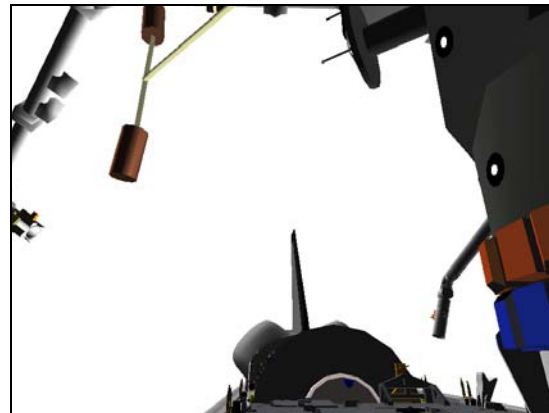

CCTV D (2,23)

Step 5:
Drive WY- (for 30.6°)
From 0.0 to -30.6

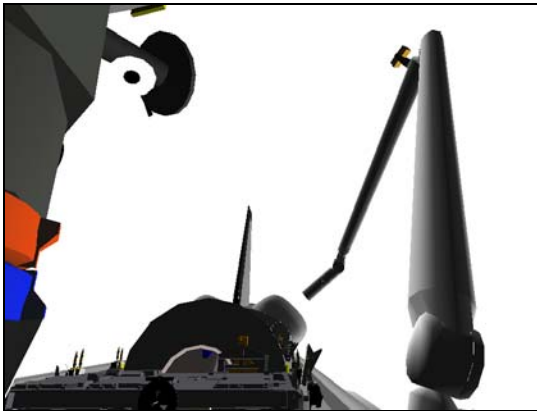

CCTV A (0,20)

Step 6:
Drive WR- (for 193.1°)
From 0.0 to -193.1

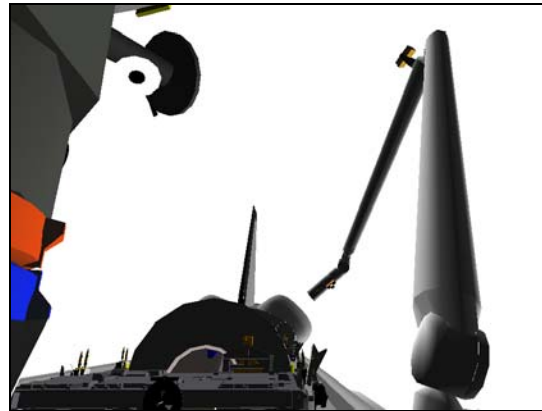

CCTV A (0,20)

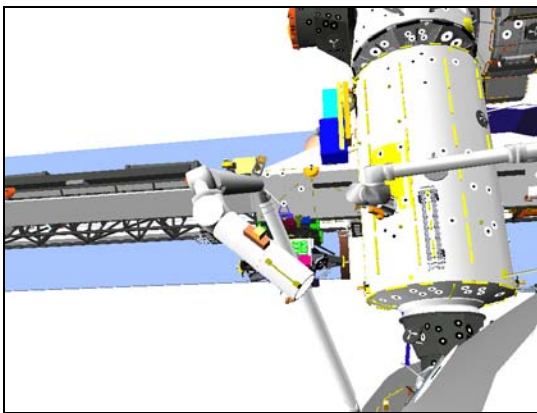

CCTV B (-10,20)

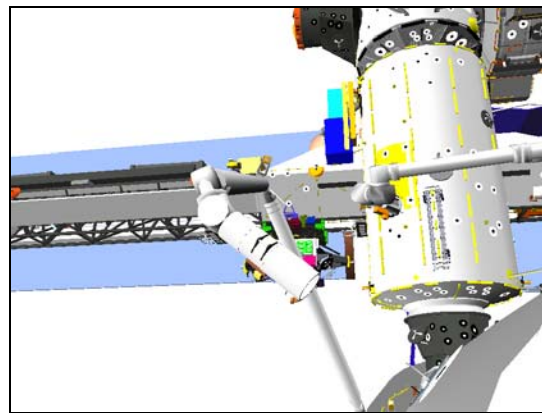

CCTV B (-10,20)

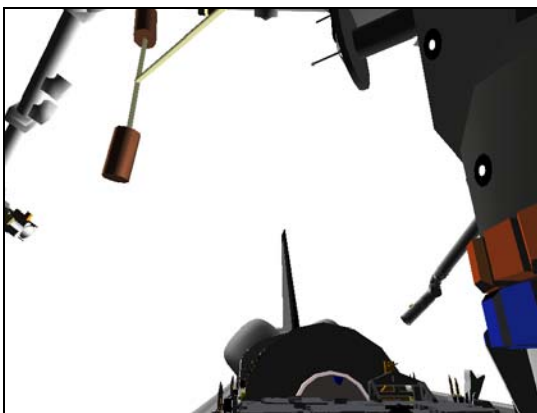

CCTV D (2,23)

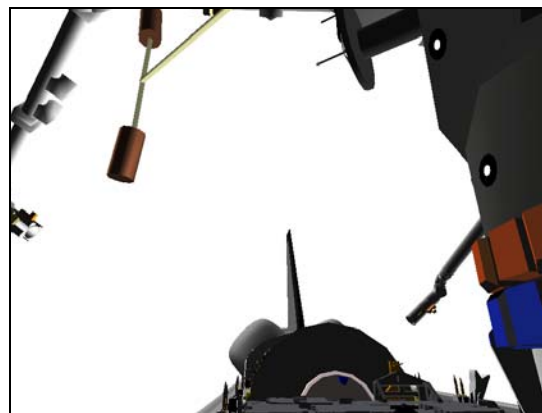

CCTV D (2,23)

3. SJ MNVR TO GRAPPLE

√CCTV – config for grapple

MON 1	EE (Elbow)
MON 2	A or Mux A/B (B)

RATE – VERN (RATE MIN tb-ON)

BRAKES – OFF (tb-OFF)

MODE – best available

Drive joints per MPLM SJ GRAPPLE IN BAY WRIST CCTV OVERLAY and diagram until EE within grapple envelope

MPLM SJ GRAPPLE IN BAY

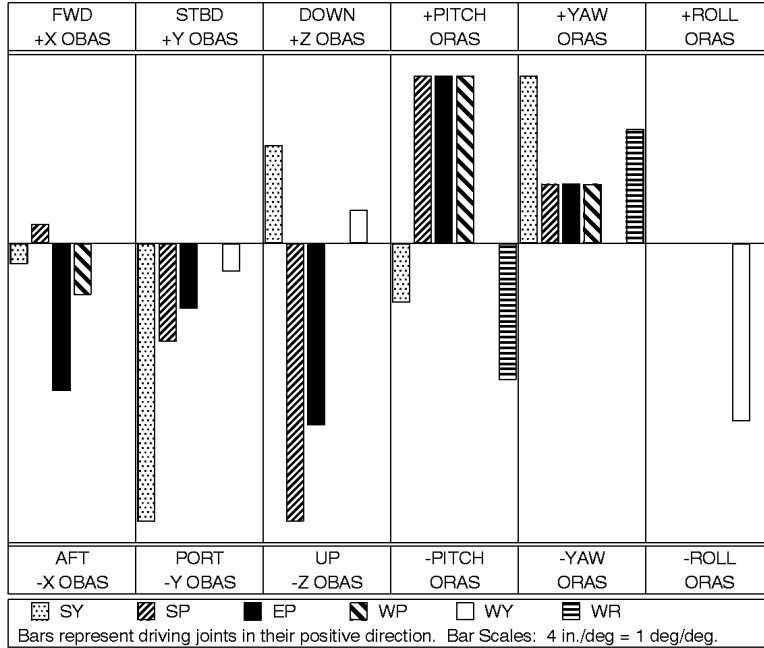

To get:	Drive:	To get:	Drive:
+X (fwd)	-EP, -WP	+PITCH	+WP, -WR
+Y (stbd)	-SY	+YAW	+SY, +WR
+Z (down)	-SP, -EP	+ROLL	-WY

Driving:	Results In:	Driving:	Results In:
+SY	-Y (port), +YAW	+WP	-X (aft), +PITCH
+SP	-Z (up), +PITCH	+WY	+Z (down), -ROLL
+EP	-Z (up), +PITCH	+WR	-PITCH

ΔSY	ΔSP	ΔEP	ΔWP	ΔWY	ΔWR
-4.6	-5.0	-4.3	+11.9	+0.0	+5.4

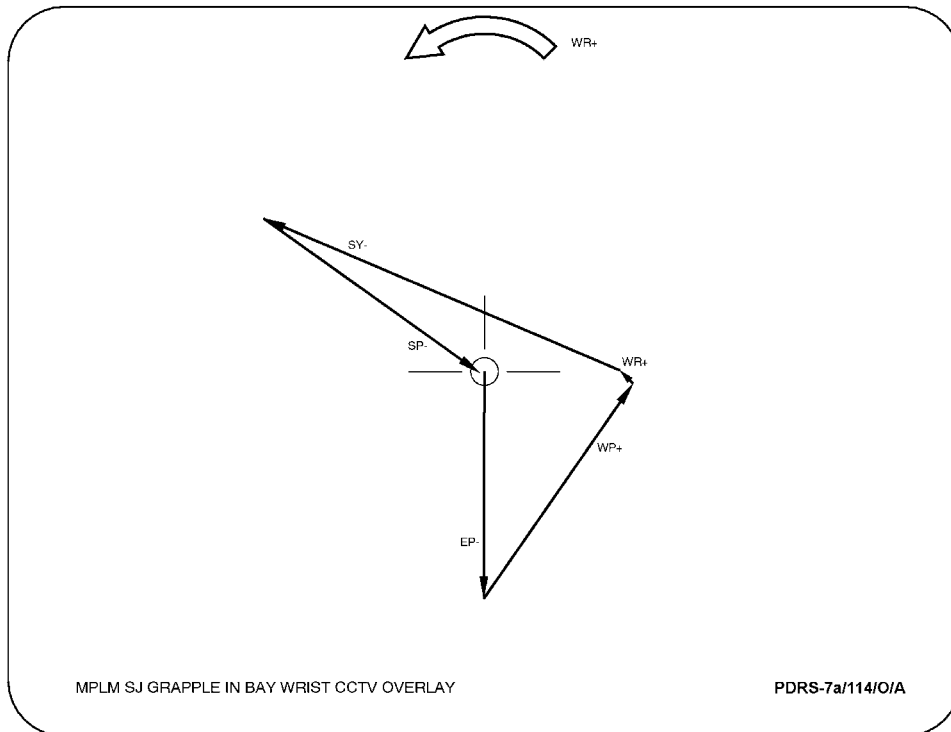

4. MPLM SJ GRAPPLE IN BAY

CAUTION
Monitor EE tb timing to prevent EE motor burnout

EE MODE – AUTO (if available)
CAPTURE sw – depress (mom)

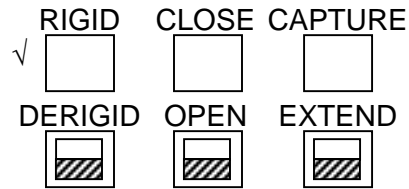

CRITICAL TIMES (28 sec total):
CAPTURE tb – gray, then
CLOSE tb – gray, 3 sec max, then
RIGID tb – gray, 25 sec max

EE MODE – OFF

- * If EE limping not available: *
- * √BRAKES – OFF (tb-OFF) *
- * MODE – TEST, ENTER (CNTL ERR msg may occur) *
- * Wait 5 sec *

BRAKES – ON (tb-ON)
MODE – not DIRECT

SM 94 PDRS CONTROL
PL ID – ITEM 3 +1(3) EXEC
INIT ID – ITEM 24 +1(3) EXEC

Record POS/ATT and Joint Angles:

	X	Y	Z	PITCH	YAW	ROLL	PL ID
							1
							3
	SY	SP	EP	WP	WY	WR	
Expected	-2.0	+57.2	-89.4	-56.5	-30.6	-187.7	

Review GENERIC END EFFECTOR CUE CARD

Record POS/ATT and Joint Angles in MPLM BERTH (NOM MPLM BERTH (CONT)) and MPLM SJ BERTH (OFF-NOM MPLM BERTH (CONT))

MPLM SJ UNBERTH (CONTINGENCY)

1. SETUP

√MPLM ROEU DEMATE (NOM MPLM INSTALL (CONT)) complete

Perform MPLM UNBERTH, steps 1-5 (NOM MPLM INSTALL (CONT))

CCTV – fully zoom out for SJ pictures

2. SJ UNBERTH

RATE – as reqd (VERN within 10 ft)

Drive joints per MPLM SJ CLEAR V-GUIDES histogram until MPLM trunnions at top of V-guides

Suggested joint drive order:

SP+,SY-,WP-,EP+,WR+



CCTV B (3,-5)

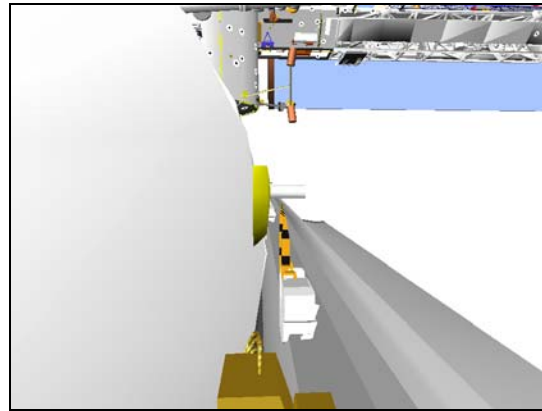

CCTV C (3,-5)

MPLM SJ CLEAR V-GUIDES

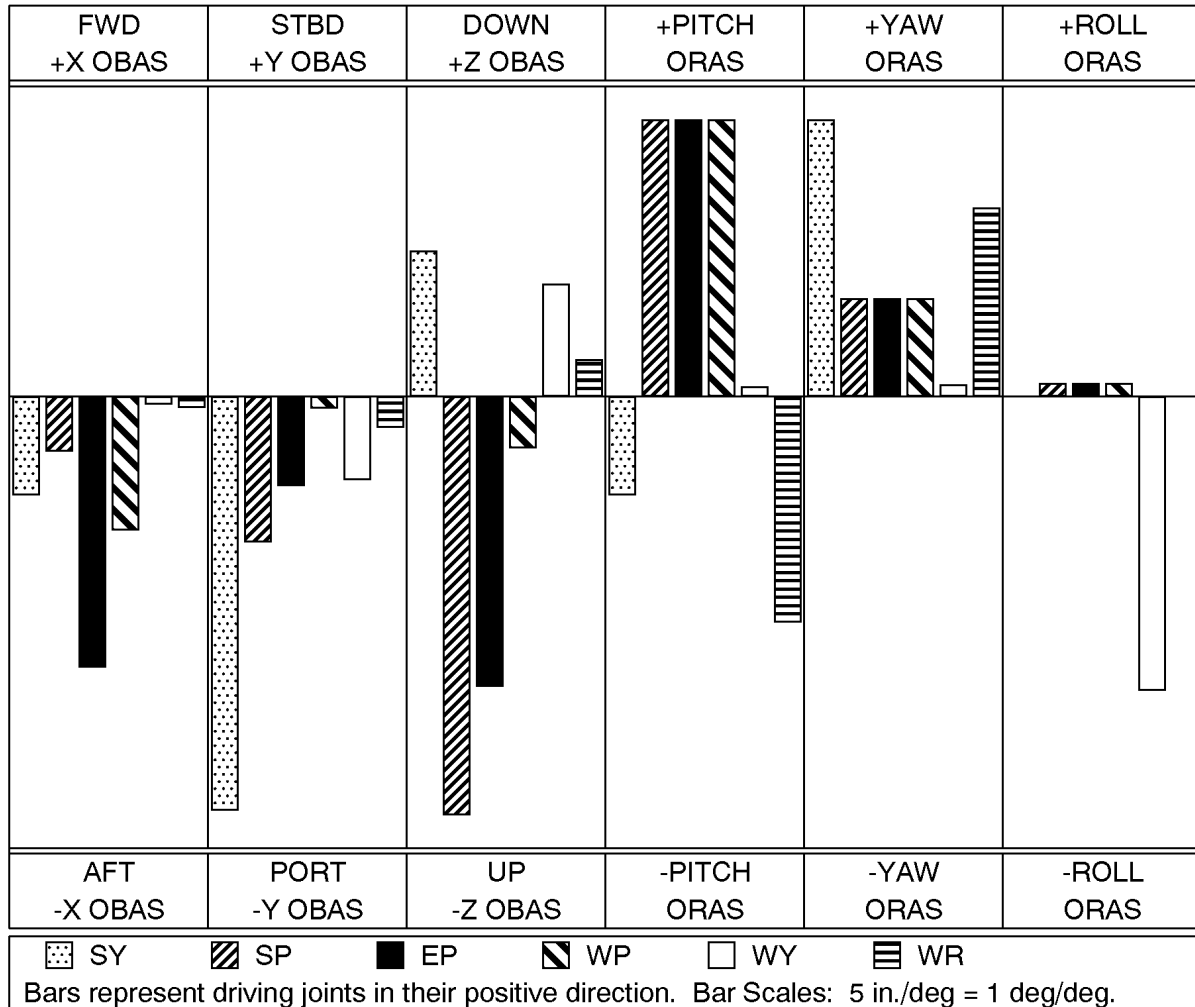

To get:	Drive:	To get:	Drive:
+X (fwd)	-EP, -WP	+PITCH	+WP, -WR
+Y (stbd)	-SY	+YAW	+SY, +WR
+Z (down)	-SP, -EP	+ROLL	-WY

Driving:	Results In:	Driving:	Results In:
+SY	-Y (port), +YAW	+WP	-X (aft), +PITCH
+SP	-Z (up), +PITCH	+WY	+Z (down), -ROLL
+EP	-Z (up), +PITCH	+WR	+Z (down), -PITCH

ΔSY	ΔSP	ΔEP	ΔWP	ΔWY	ΔWR
-1.2	+2.6	+1.5	-3.4	+0.1	+1.5

A6U √PL RETEN RDY 1,2,3,4 tb (four) – bp

3. SJ MNVR TO MPLM LOW HOVER

Drive joints per MPLM SJ MNVR TO LOW HOVER table or histogram to obtain desired motion until MPLM at Low Hover posn

NOTE

Monitor clearance between MPLM and LMC

MPLM SJ MNVR TO LOW HOVER

ΔSY	ΔSP	ΔEP	ΔWP	ΔWY	ΔWR
-10.4	+3.6	+36.9	-34.4	+0.9	+11.9

	Z	SY	SP	EP	WP	WY	WR
Top of Guides	-439	-3.2	+59.8	-87.9	-59.9	-30.5	-186.2
	-444	-3.5	+60.3	-87.5	-60.6	-30.5	-185.9
	-449	-3.7	+60.7	-87.1	-61.3	-30.5	-185.6
	-454	-4.0	+61.2	-86.7	-62.0	-30.5	-185.3
	-459	-4.2	+61.6	-86.3	-62.7	-30.5	-185.0
	-464	-4.5	+62.0	-85.8	-63.4	-30.5	-184.7
	-469	-4.7	+62.4	-85.4	-64.1	-30.4	-184.5
	-474	-5.0	+62.8	-84.9	-64.9	-30.4	-184.2
	-479	-5.2	+63.1	-84.4	-65.6	-30.4	-183.9
	-484	-5.5	+63.5	-83.8	-66.3	-30.4	-183.6
	-489	-5.7	+63.8	-83.3	-67.0	-30.4	-183.3
	-494	-6.0	+64.1	-82.7	-67.8	-30.4	-183.0
	-499	-6.2	+64.4	-82.1	-68.5	-30.4	-182.7
	-509	-6.7	+64.9	-80.8	-70.0	-30.3	-182.2
	-519	-7.2	+65.4	-79.5	-71.5	-30.3	-181.6
	-529	-7.7	+65.7	-78.0	-73.1	-30.2	-181.0
	-539	-8.2	+66.0	-76.5	-74.6	-30.2	-180.5
	-549	-8.7	+66.3	-74.8	-76.2	-30.2	-179.9
	-559	-9.2	+66.4	-73.1	-77.8	-30.1	-179.3
	-569	-9.7	+66.5	-71.2	-79.4	-30.1	-178.8
	-579	-10.2	+66.5	-69.2	-81.1	-30.0	-178.2
	-589	-10.7	+66.4	-67.2	-82.8	-30.0	-177.7
	-599	-11.1	+66.2	-64.9	-84.5	-29.9	-177.1
	-609	-11.6	+65.9	-62.6	-86.3	-29.9	-176.5
	-619	-12.1	+65.5	-60.1	-88.1	-29.8	-176.0
	-629	-12.6	+64.9	-57.4	-90.0	-29.7	-175.5
	-636	-12.9	+64.5	-55.4	-91.4	-29.7	-175.1
	-643	-13.3	+64.0	-53.3	-92.8	-29.6	-174.7
MPLM Low Hover	-650	-13.6	+63.4	-51.0	-94.3	-29.6	-174.3

MPLM SJ MNVR TO LOW HOVER

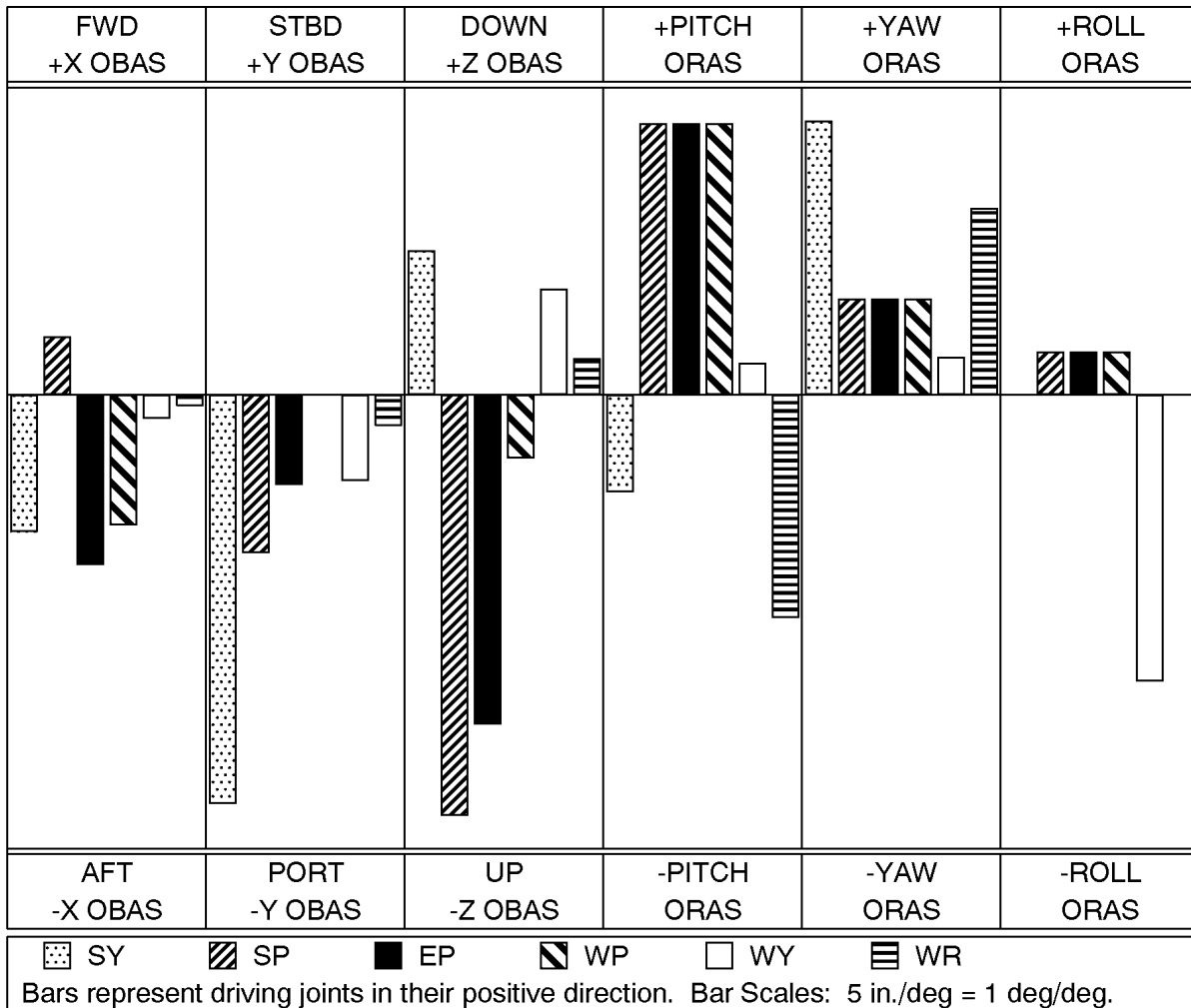

To get:	Drive:	To get:	Drive:
+X (fwd)	-EP, -WP	+PITCH	+WP, -WR
+Y (stbd)	-SY, -SP	+YAW	+SY, +WR
+Z (down)	-SP, -EP	+ROLL	-WY

Driving:	Results In:	Driving:	Results In:
+SY	-Y (port), +YAW	+WP	-X (aft), +PITCH
+SP	-Z (up), +PITCH	+WY	+Z (down), -ROLL
+EP	-Z (up), +PITCH	+WR	+Z (down), -PITCH

Δ SY	Δ SP	Δ EP	Δ WP	Δ WY	Δ WR
-10.4	+3.6	+36.9	-34.4	+0.9	+11.9

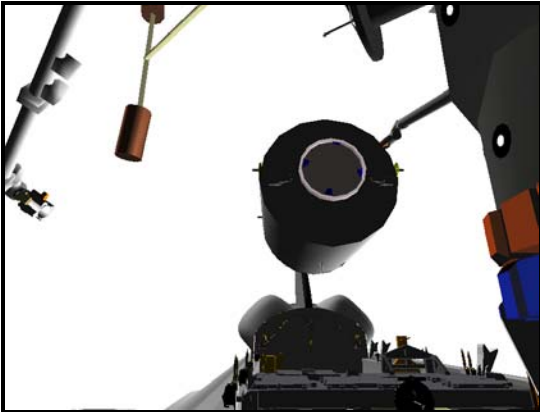

CCTV D (0,20)

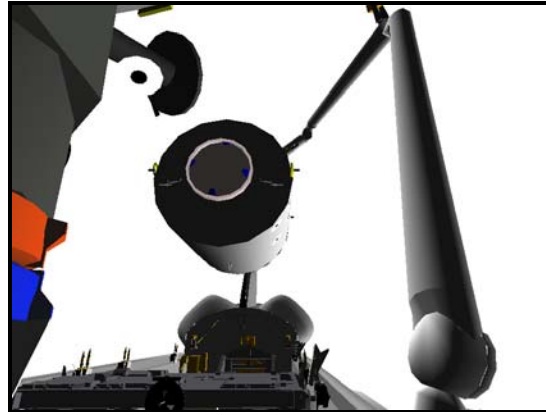

CCTV A (0,20)

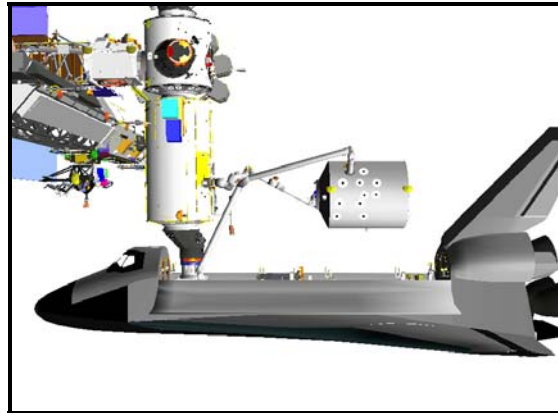

√ POS/ATT and Joint Angles at MPLM LOW HOVER posn:

X	Y	Z	PITCH	YAW	ROLL	PL ID
-1106	0	-650	0	0	0	1
-992	0	-636	0	0	270	2
SY	SP	EP	WP	WY	WR	
-13.6	+63.4	-51.0	-94.3	-29.6	-174.3	

SSP 2

Deactivate KEEL CCTV:

MPLM KEEL CAM HTR/ILLUM PWR – Toggle until illuminator OFF
(leave sw in ON posn)

PWR – OFF

BRAKES – ON (tb-ON)

MODE – not DIRECT

MPLM SJ INSTALL (CONTINGENCY)

1. MNVR TO MPLM PRE-INSTALL POSN

- CCTV – fully zoom out for SJ pictures
 - reset PAN/TILT values for CCTV A, B, C, and D

SM 94 PDRS CONTROL

PL ID – ITEM 3 +2 EXEC

INIT ID – ITEM 24 +2 EXEC

RATE – as reqd (VERN within 10 ft)

BRAKES – OFF (tb-OFF)

MODE – best available

Mnvr to MPLM Pre-Install posn:

	SY	SP	EP	WP	WY	WR	
√Low Hover	-13.6	+63.4	-51.0	-94.3	-29.6	-174.3	
1		+80.0					
2						-77.0	
3				+9.5			
4					-34.6		
5			-74.3				
6		+103.0					
7	-49.5						
Pre-Install	-49.5	+103.0	-74.3	+9.5	-34.6	-77.0	
	X	Y	Z	PITCH	YAW	ROLL	PL ID
	-744	0	-980	1	0	0	2

BRAKES – ON (tb-ON)

MODE – not DIRECT

Step 1:

Drive SP+ (for 16.6°)
From +63.4 to +80.0

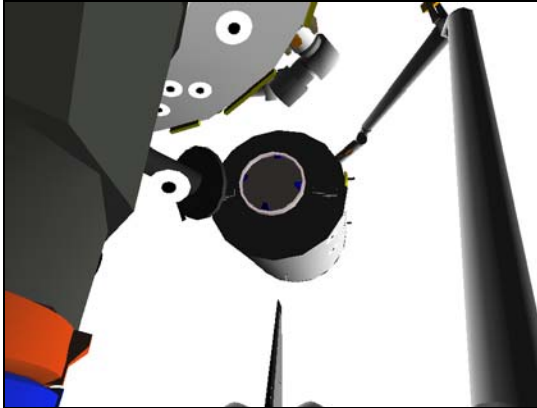

CCTV A (-5,35)

Step 2:

Drive WR+ (for 97.3°)
From -174.3 to -77.0

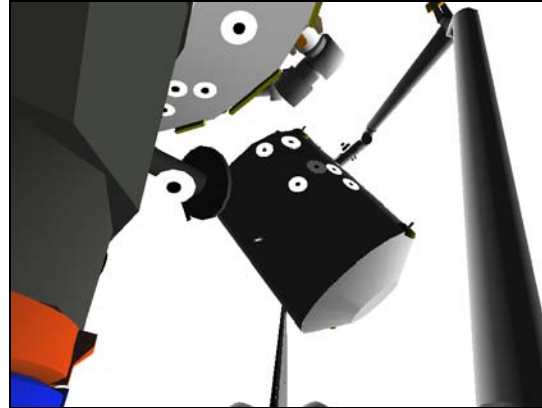

CCTV A (-5,35)

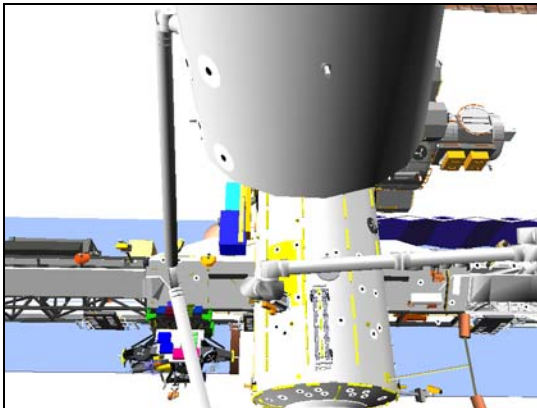

CCTV B (2,30)

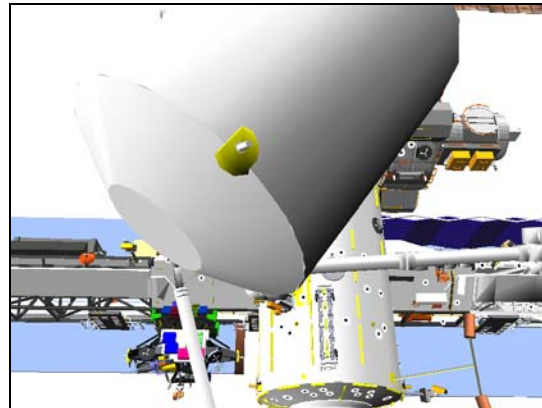

CCTV B (2,30)

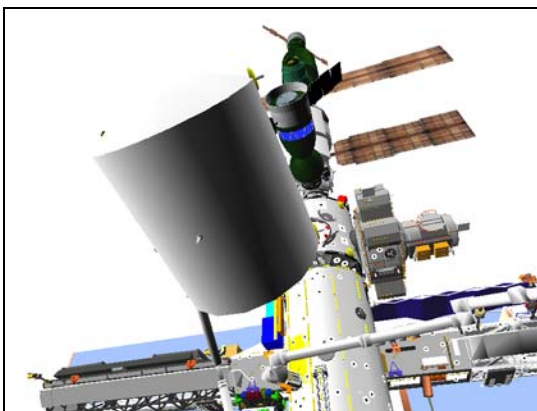

CCTV C (-17,45)

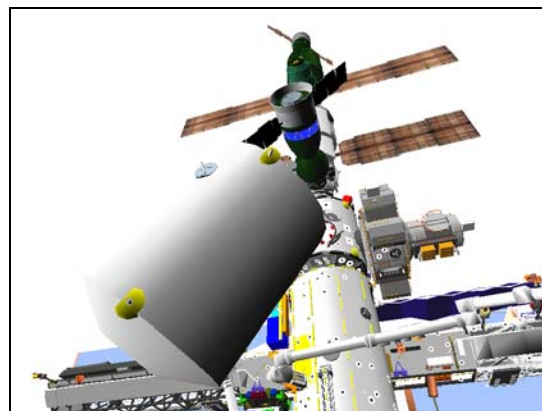

CCTV C (-17,45)

Step 3:

Drive WP+ (for 103.8°)
From -94.3 to +9.5

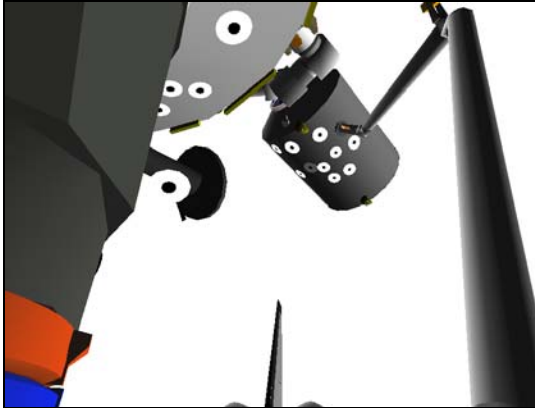

CCTV A (-5,35)

Step 4:

Drive WY- (for 5.0°)
From -29.6 to -34.6

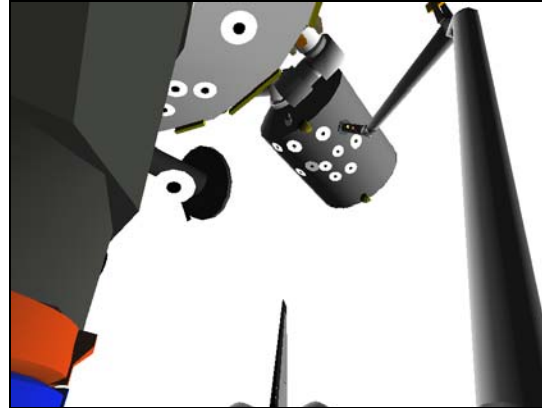

CCTV A (-5,35)

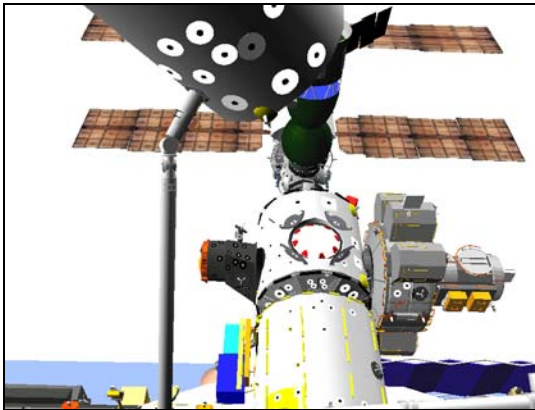

CCTV B (2,45)

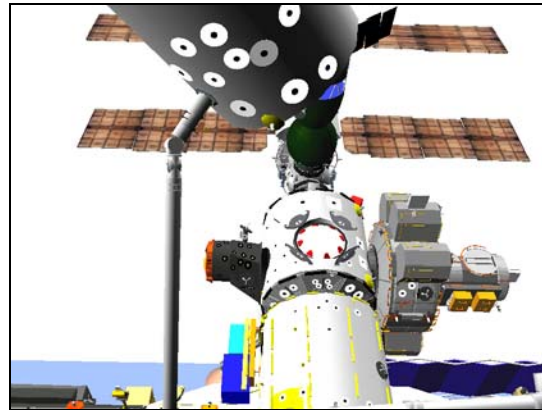

CCTV B (2,45)



CCTV C (-17,45)

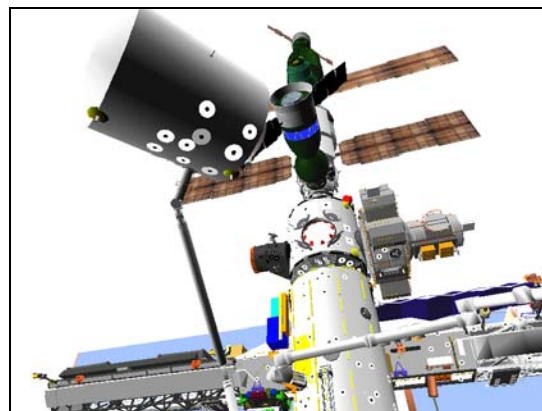

CCTV C (-17,45)

Step 5:

Drive EP- (for 23.3°)
From -51.0 to -74.3

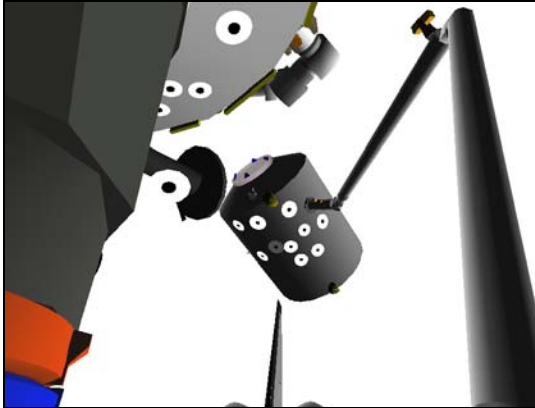

CCTV A (-5,35)

Step 6:

Drive SP+ (for 23.0°)
From +80.0 to +103.0

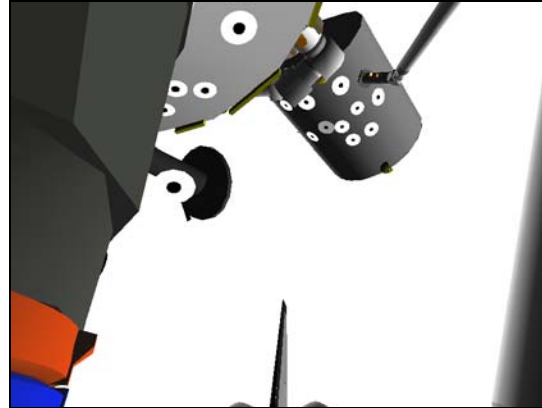

CCTV A (-5,35)

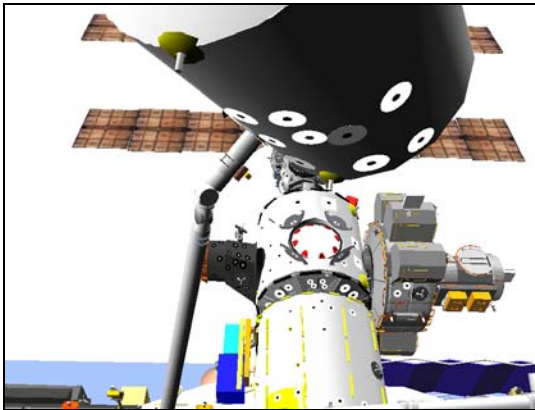

CCTV B (2,45)

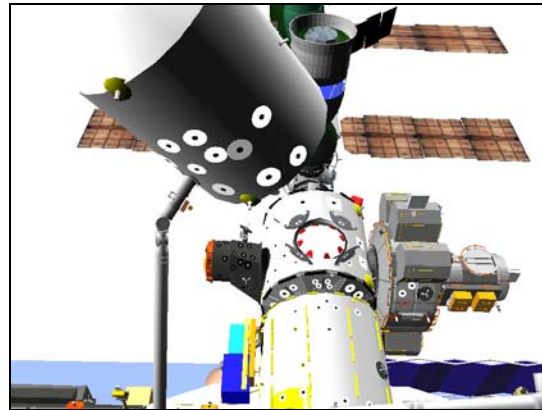

CCTV B (2,45)

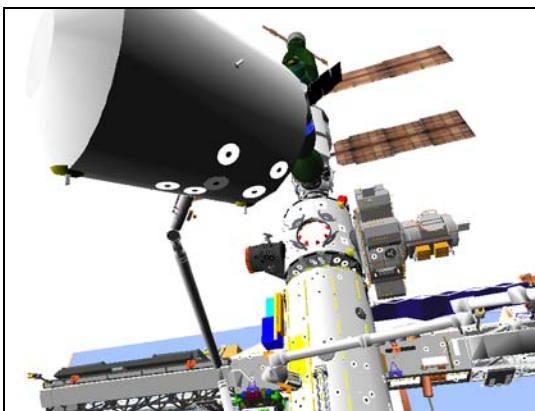

CCTV C (-17,45)



CCTV C (-17,45)

Step 7:

Drive SY- (for 35.9°)
From -13.6 to -49.5

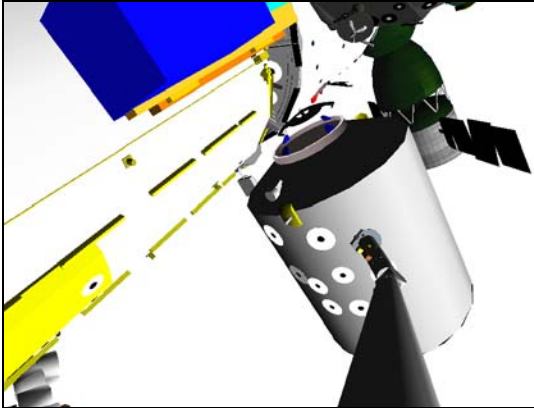

ELBOW (-18,7)

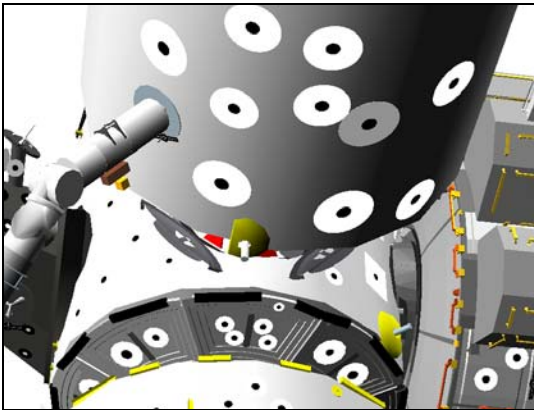

CCTV B (9,41)



CCTV C (-17,45)

A7U

2. SETUP FOR INSTALLATION

- CCTV – config for install
 - install MPLM CBCS CCTV OVERLAY
 - RMS ELBOW, CBCS
 - fully zoom out for SJ pictures

√CBCS setup complete

√1.505 NODE 1 CBM VERIFY PRE-MATE STATUS (SODF: S&M: NOMINAL: CBM) complete

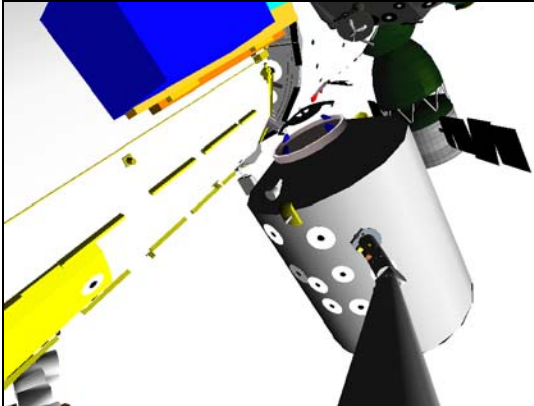

ELBOW (-18,7)

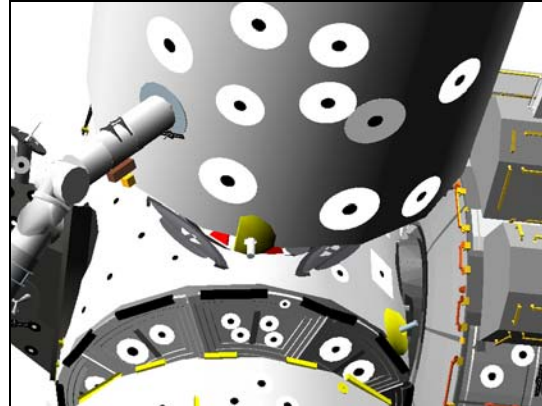

CCTV B (9,41)

PCS

3. SJ MNVR TO READY-TO-LATCH POSN

MCS: MCS Configuration: US GNC Inhibits

US GNC Inhibits

√Desat Request – Inh

RATE – VERN (RATE MIN tb-ON)

BRAKES – OFF (tb-OFF)

MODE – best available

Mnvr MPLM until RTLs achieved (expected X: -713)

Mnvr to as follows (reference diagrams as reqd):

√Pre-Install
Expected RTL

SY	SP	EP	WP	WY	WR		
-49.5	+103.0	-74.3	+9.5	-34.6	-77.0		
-56.9	+106.8	-77.1	+5.7	-28.6	-82.2		
X	Y	Z	PITCH	YAW	ROLL	PL ID	
-713	1	-980	1	0	0	2	

Suggested joint drive order:

SY-,SP+,EP-,WR-,WY+,WP-

MPLM SJ INSTALL

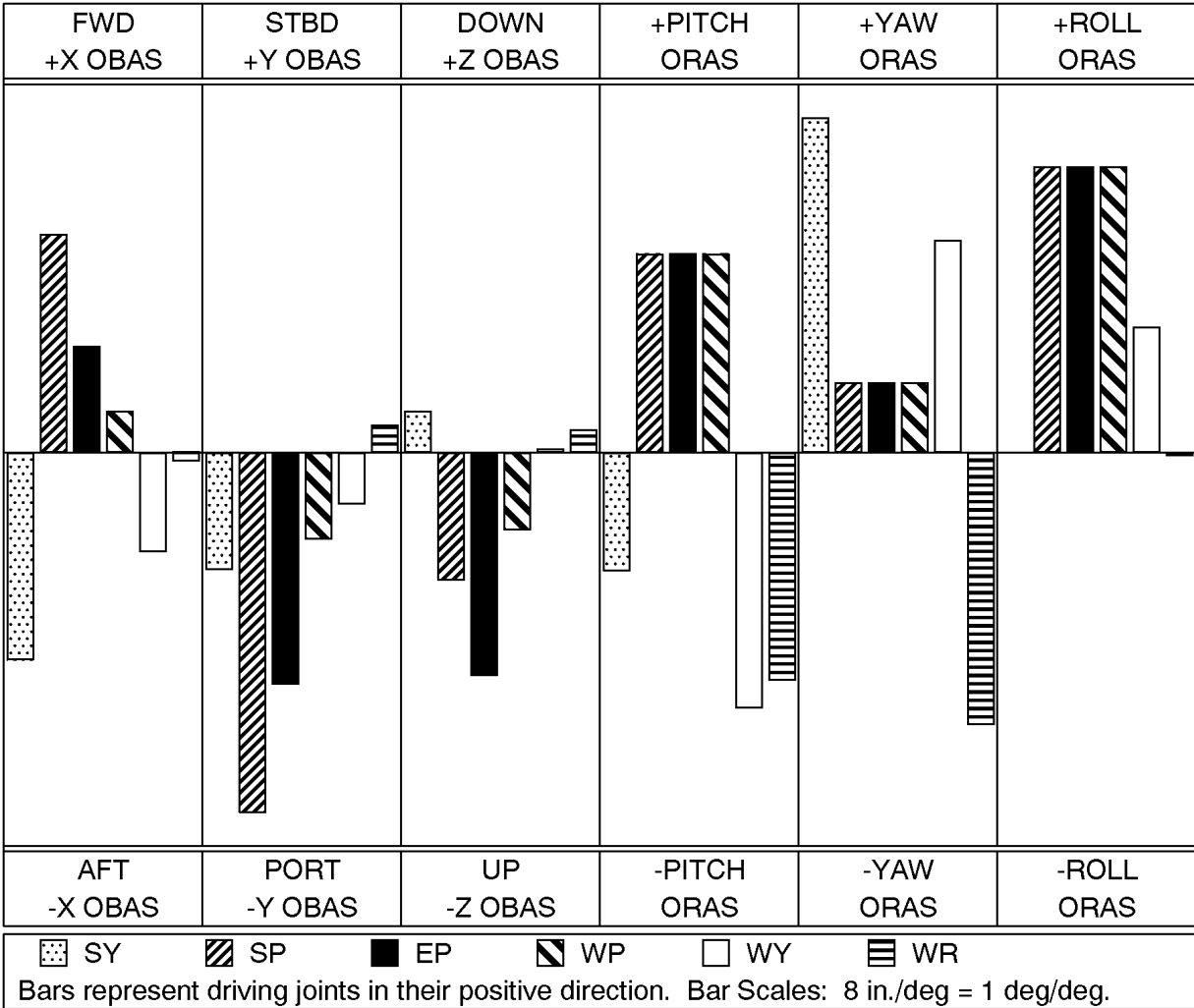

To get:	Drive:	To get:	Drive:
+X (fwd)	-SY, +SP	+PITCH	-WY, -WR
+Y (stbd)	-SP, -EP	+YAW	+SY, -WR
+Z (down)	-EP, -SP	+ROLL	+WP, +EP

Driving:	Results In:	Driving:	Results In:
+SY	-X (aft), +YAW	+WP	-Y (port), +ROLL
+SP	-Y (port), +ROLL	+WY	-X (aft), -PITCH
+EP	-Y (port), +ROLL	+WR	+Y (stbd), -YAW

ΔSY	ΔSP	ΔEP	ΔWP	ΔWY	ΔWR
-8.7	+4.3	-3.0	-4.5	+7.1	-6.0

MPLM SJ INSTALL

ΔSY	ΔSP	ΔEP	ΔWP	ΔWY	ΔWR
-8.7	+4.3	-3.0	-4.5	+7.1	-6.0

	X	SY	SP	EP	WP	WY	WR
MPLM Pre-Install	-744	-49.5	+103.0	-74.3	+9.5	-34.6	-77.0
	-741	-50.1	+103.4	-74.6	+9.1	-34.1	-77.5
	-738	-50.8	+103.8	-74.9	+8.8	-33.6	-77.9
	-735	-51.5	+104.2	-75.1	+8.4	-33.0	-78.4
	-732	-52.2	+104.5	-75.4	+8.0	-32.5	-78.9
	-730	-52.6	+104.8	-75.6	+7.7	-32.1	-79.3
	-728	-53.1	+105.0	-75.8	+7.5	-31.7	-79.6
	-726	-53.6	+105.3	-75.9	+7.2	-31.3	-79.9
	-724	-54.1	+105.5	-76.1	+7.0	-30.9	-80.3
	-722	-54.6	+105.7	-76.3	+6.7	-30.5	-80.6
	-720	-55.1	+106.0	-76.4	+6.5	-30.1	-80.9
	-719	-55.3	+106.1	-76.5	+6.3	-29.9	-81.1
	-718	-55.6	+106.2	-76.6	+6.2	-29.7	-81.3
	-717	-55.8	+106.3	-76.7	+6.1	-29.5	-81.5
	-716	-56.1	+106.4	-76.7	+6.0	-29.2	-81.6
Expected RTL	-715	-56.4	+106.5	-76.8	+5.8	-29.0	-81.8
	-714	-56.6	+106.7	-76.9	+5.7	-28.8	-82.0
	-713	-56.9	+106.8	-77.0	+5.6	-28.6	-82.1
	-712	-57.1	+106.9	-77.0	+5.5	-28.4	-82.3
	-711	-57.4	+107.0	-77.1	+5.4	-28.2	-82.5
MPLM Install	-710	-57.7	+107.1	-77.2	+5.2	-27.9	-82.7
	-709	-57.9	+107.2	-77.2	+5.1	-27.7	-82.8
	-708	-58.2	+107.3	-77.3	+5.0	-27.5	-83.0

- * Repeat step 3, correcting for misalignments *
- * until at least 3 of 4 RTLs indicated *

4. FIRST STAGE CAPTURE

Go to MPLM INSTALL, steps 6 and 7 (NOM MPLM INSTALL (CONT))

MPLM SJ UNGRAPPLE ON NODE NADIR (CONTINGENCY)

1. SETUP

√1.506 NODE 1 CBM CAPTURE/ABOLT, step 4 (SODF: S&M: NOMINAL: CBM) complete

PCS MCS: MCS Configuration: US GNC Inhibits
US GNC Inhibits

cmd Desat Request Enable (Verify - Ena)

A7U CCTV – config for ungrapple
 – RMS WRIST, zoom 34.0 HFOV
 focus 5 ft

SM 94 PDRS CONTROL

PL ID – ITEM 3 +0 EXEC
 INIT ID – ITEM 24 +0 EXEC

2. MPLM UNGRAPPLE

MON 1	EE (Elbow)
MON 2	B (C)

RATE – VERN (RATE MIN tb-ON) within 10 ft
 BRAKES – OFF (tb-OFF)
 MODE – best available

CAUTION
 Monitor EE tb timing to prevent EE motor burnout

EE MODE – MAN

MAN CONTR – DERIGID (hold until DERIGID tb-gray, 5 sec max)

RELEASE sw – depress (hold until OPEN tb-gray, 3 sec max)

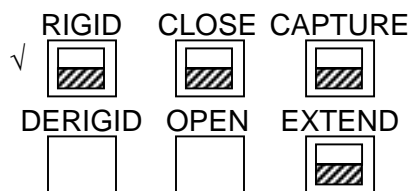

CRITICAL TIMES (28 sec total):

DERIGID tb – gray, 5 sec max, then

OPEN tb – gray, 3 sec max, then

EXTEND tb – gray, 20 sec max

3. MNVR ARM CLEAR OF MPLM

Drive joints per MPLM SJ UNGRAPPLE ON NODE NADIR WRIST CCTV OVERLAY until EE clear of grapple fixture

EE MAN CONTR – DERIGID (hold until EXTEND tb-gray, 20 sec max)

MODE – OFF

BRAKES – ON (tb-ON)

MODE – not DIRECT

JOINT – CRIT TEMP

MPLM SJ UNGRAPPLE ON NODE NADIR

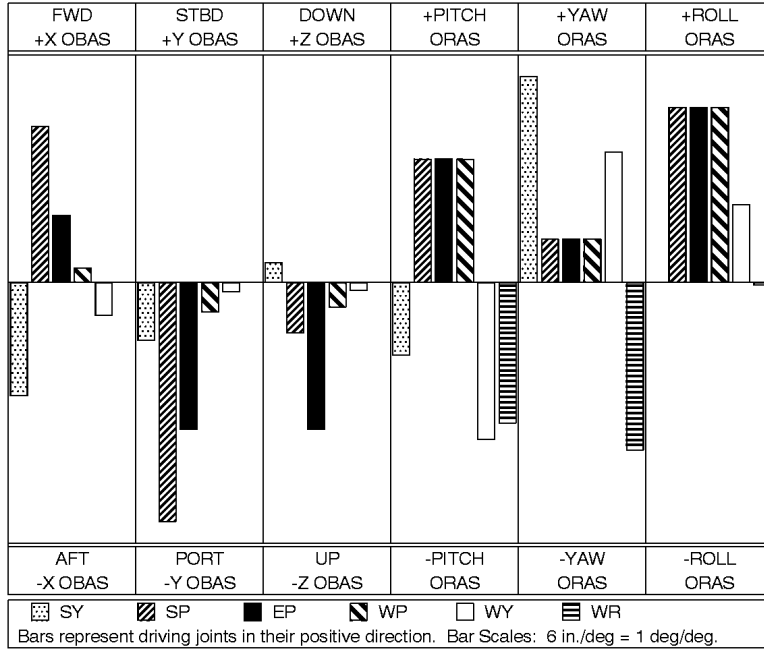

To get:	Drive:	To get:	Drive:
+X (fwd)	+SP, -SY	+PITCH	-WY, -WR
+Y (stbd)	-SP, -EP	+YAW	+SY, -WR
+Z (down)	-EP	+ROLL	+WP, +EP

Driving:	Results In:	Driving:	Results In:
+SY	-X (aft), +YAW	+WP	-Y (port), +ROLL
+SP	-Y (port), +ROLL	+WY	-X (aft), -PITCH
+EP	-Y (port), +ROLL	+WR	-YAW

ΔSY	ΔSP	ΔEP	ΔWP	ΔWY	ΔWR
+11.2	+11.	-14.7	+7.3	-9.0	+8.0

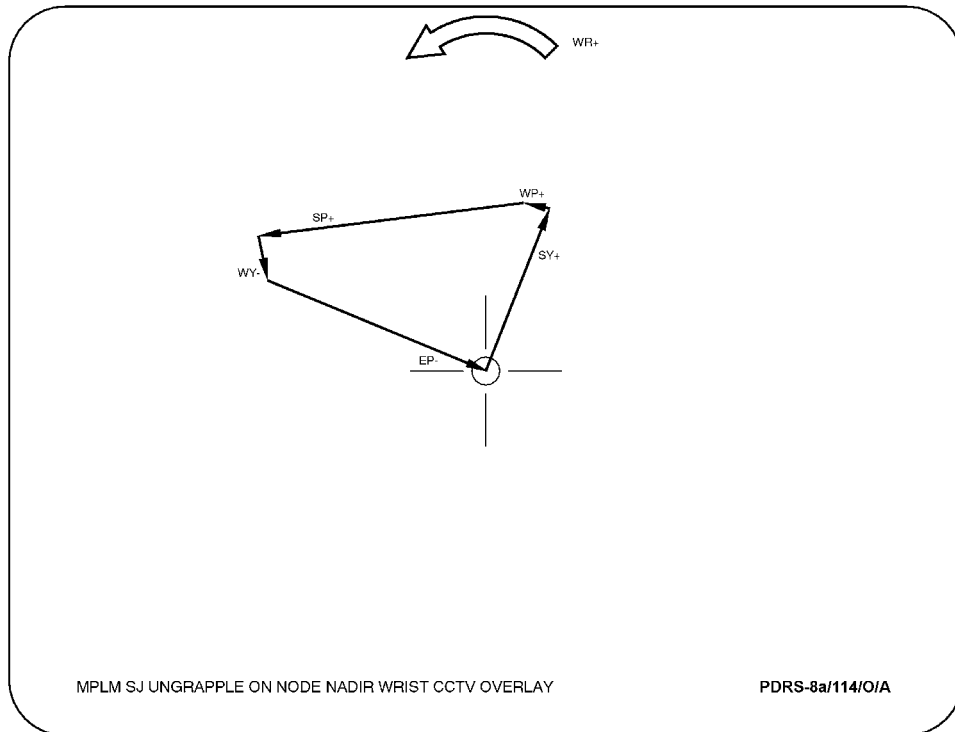

MPLM JETTISON (CONTINGENCY)

X	Y	Z	PITCH	YAW	ROLL	PL ID
-715	-733	-656	330	5	211	1
-622	-729	-723	330	5	121	2
SY	SP	EP	WP	WY	WR	
+60.0	+60.0	-30.0	0.0	0.0	+50.0	

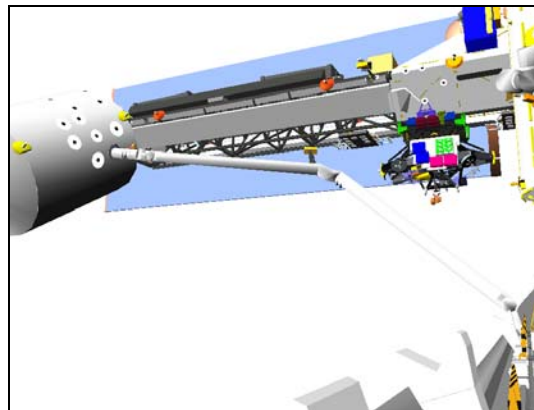
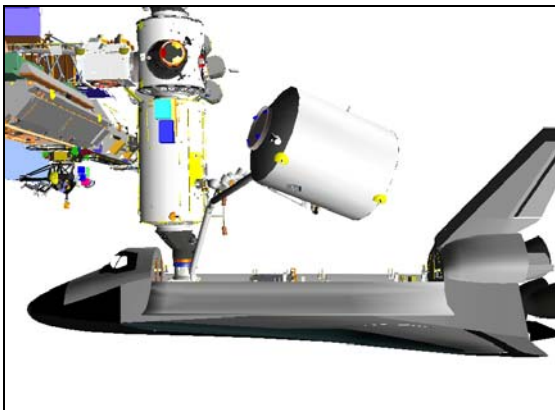

CCTV B (-25,10)

OFF-NOMINAL MPLM BERTH (CONTINGENCY)

MPLM SJ GRAPPLE ON NODE NADIR (CONTINGENCY)	FS 9-2
UNINSTALL (CONTINGENCY).....	FS 9-9
BERTH (CONTINGENCY)	FS 9-14
UNGRAPPLE IN BAY (CONTINGENCY)	FS 9-23

**OFF-NOM MPLM
BERTH (CONT)**

MPLM SJ GRAPPLE ON NODE NADIR (CONTINGENCY)

- A7U
1. SETUP
 CCTV – config for grapple
 - install PDRS TARGET OVERLAY FOR CTVM
 - RMS WRIST, zoom 34.0 HFOV
 focus 5 ft
 - reset PAN/TILT values for CCTV A, B, C, and D
 - fully zoom out for SJ pictures
 Maintain eyepoint approx 18 in when using grapple overlay

SM 94 PDRS CONTROL

- √ PL ID, ITEM 3: 0
- √ INIT ID, ITEM 24: 0

2. SJ MNVR TO PRE-GRAPPLE
 RATE – as reqd (VERN within 10 ft)
 BRAKES – OFF (tb-OFF)
 MODE – best available

Mnvr to PRE-GRAPPLE posn:

	SY	SP	EP	WP	WY	WR	
Pre-Cradle	0.0	+25.0	-25.0	+5.0	0.0	0.0	
		+118.9					
			-92.0				
	-47.0						
				+12.3			
					-36.5		
						-75.0	
Pre-Grapple	-47.0	+118.9	-92.0	+12.3	-36.5	-75.0	
	X	Y	Z	PITCH	YAW	ROLL	PL ID
	-777	-95	-867	91	320	331	0

- BRAKES – ON (tb-ON)
- MODE – not DIRECT

OFF-NOM MPLM BERTH (CONT)

Step 1:

Drive SP+ (for 93.9°)
From +25.0 to +118.9

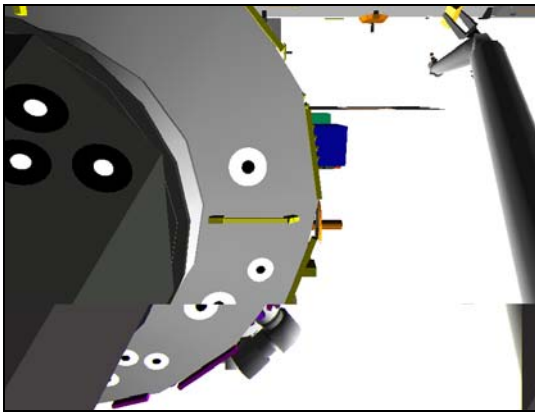

CCTV A (0,75)

Step 2:

Drive EP- (for 67.0°)
From -25.0 to -92.0

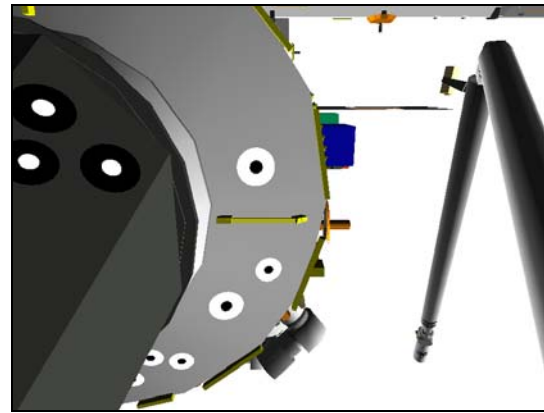

CCTV A (0,75)

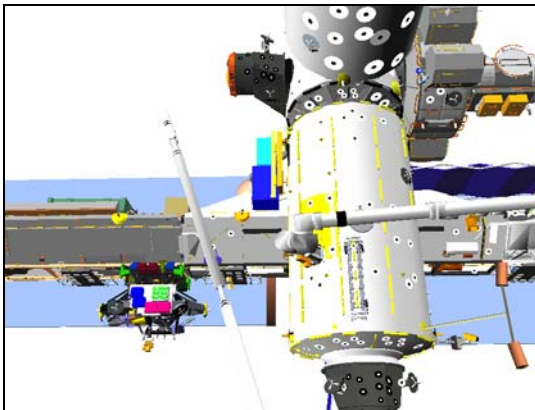

CCTV B (-2,25)

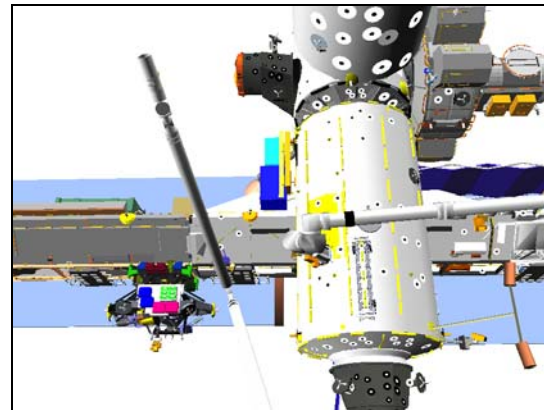

CCTV B (-2,25)

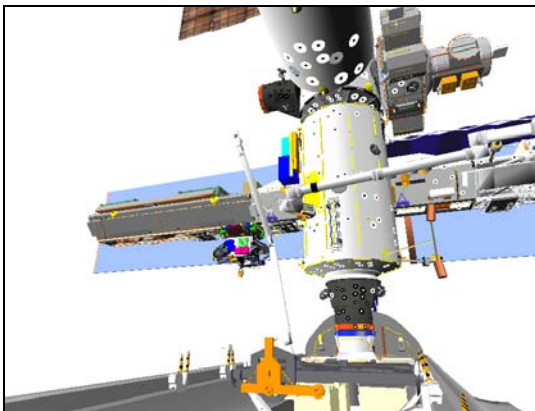

CCTV C (-20,20)

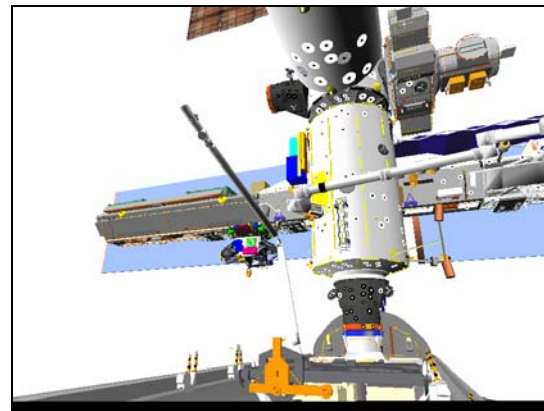

CCTV C (-20,20)

Step 3:

Drive SY- (for 47.0°)
From 0.0 to -47.0

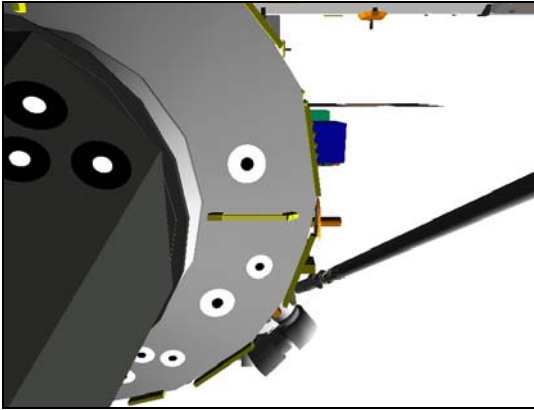

CCTV A (0,75)

Step 4:

Drive WP+ (for 7.3°)
From +5.0 to +12.3



CCTV A (0,75)

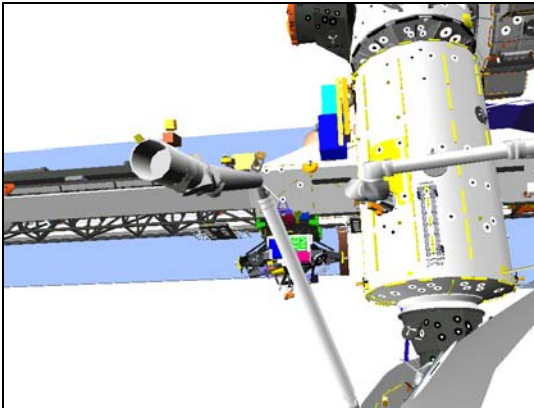

CCTV B (-2,25)

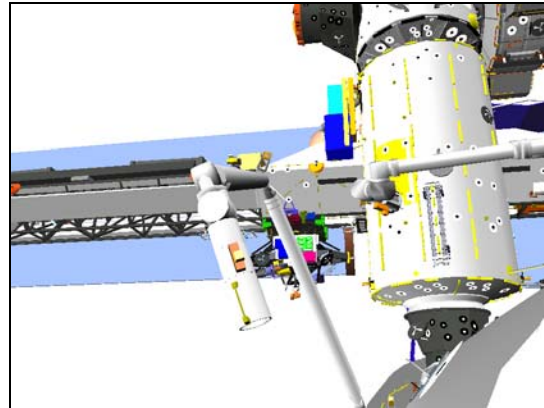

CCTV B (-2,25)

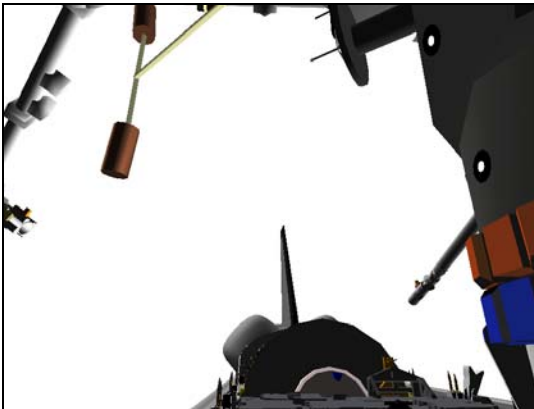

CCTV C (-20,20)

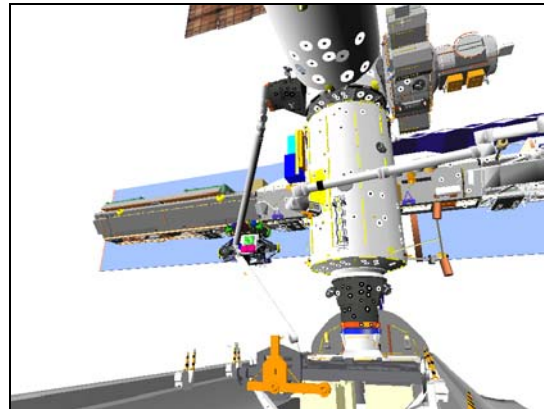

CCTV C (-20,20)

Step 5:

Drive WY- (for 36.5°)
From 0.0 to -36.5

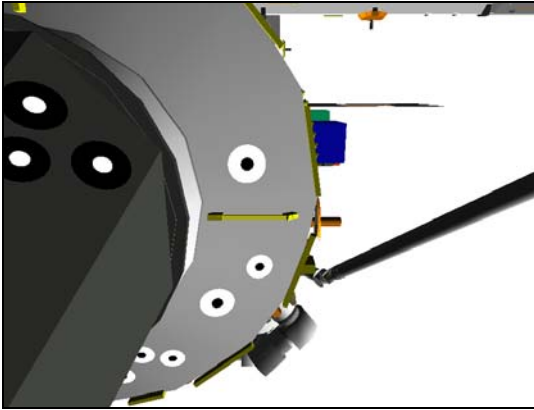

CCTV A (0,75)

Step 6:

Drive WR- (for 75.0°)
From 0.0 to -75.0

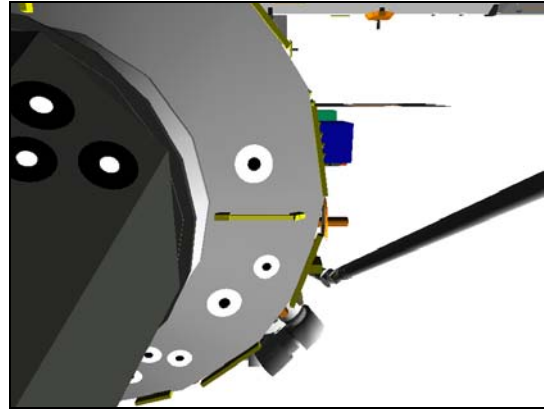

CCTV A (0,75)

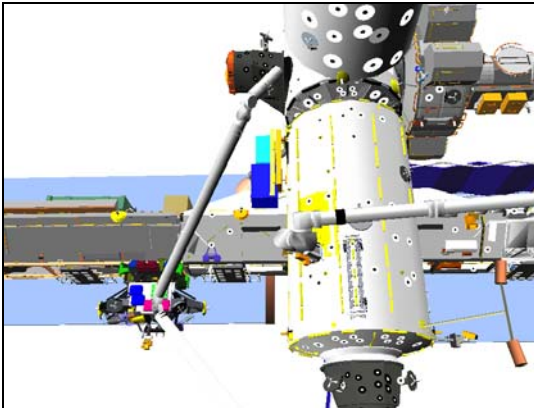

CCTV B (-2,25)

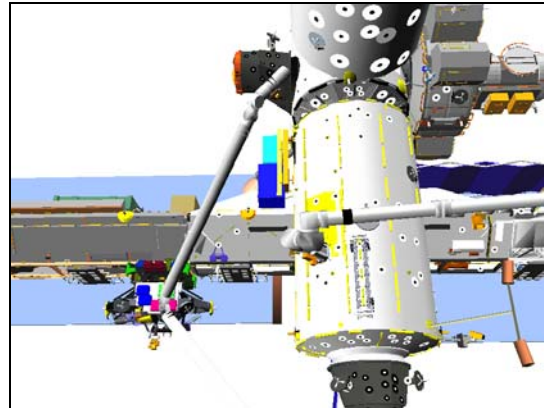

CCTV B (-2,25)

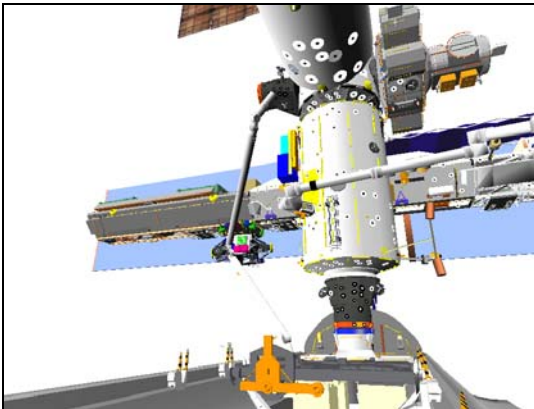

CCTV C (-20,20)

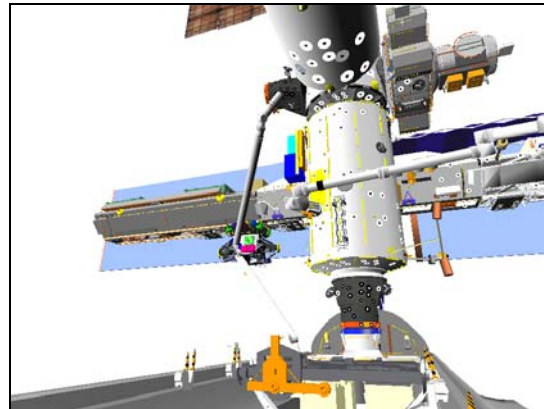

CCTV C (-20,20)

3. SJ MNVR TO GRAPPLE
√CCTV – config for grapple

MON 1	EE (Elbow)
MON 2	C (B)

RATE – VERN (RATE MIN tb-ON)
BRAKES – OFF (tb-OFF)
MODE – best available

Drive joints per MPLM SJ GRAPPLE ON NODE NADIR WRIST CCTV OVERLAY and histogram until EE within grapple envelope

MPLM SJ GRAPPLE ON NODE NADIR

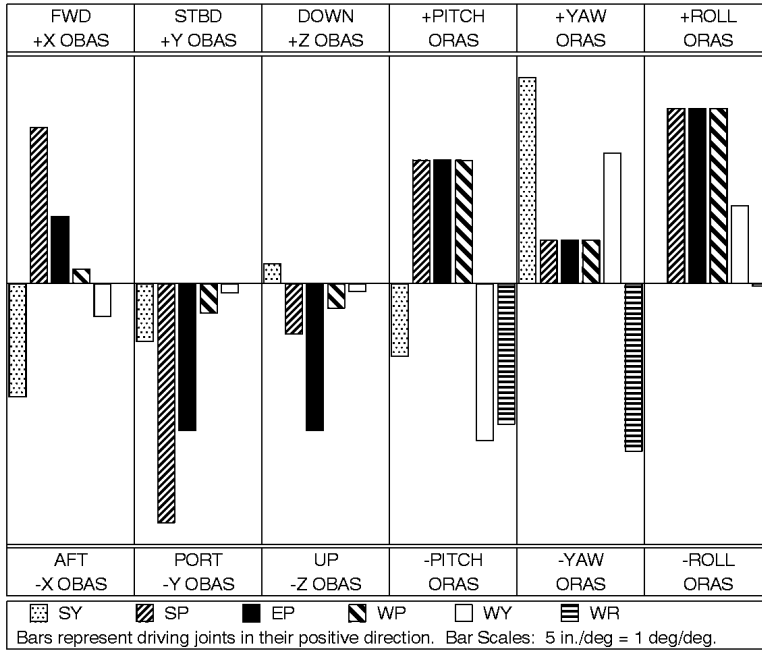

To get:	Drive:	To get:	Drive:
+X (fwd)	+SP, -SY	+PITCH	-WY, -WR
+Y (stbd)	-SP, -EP	+YAW	+SY, -WR
+Z (down)	-EP	+ROLL	+WP, +EP

Driving:	Results In:	Driving:	Results In:
+SY	-X (aft), +YAW	+WP	-Y (port), +ROLL
+SP	-Y (port), +ROLL	+WY	-X (aft), -PITCH
+EP	-Y (port), +ROLL	+WR	-YAW

ΔSY	ΔSP	ΔEP	ΔWP	ΔWY	ΔWR
-11.	-11.	+14.7	-7.3	+9.0	-8.0

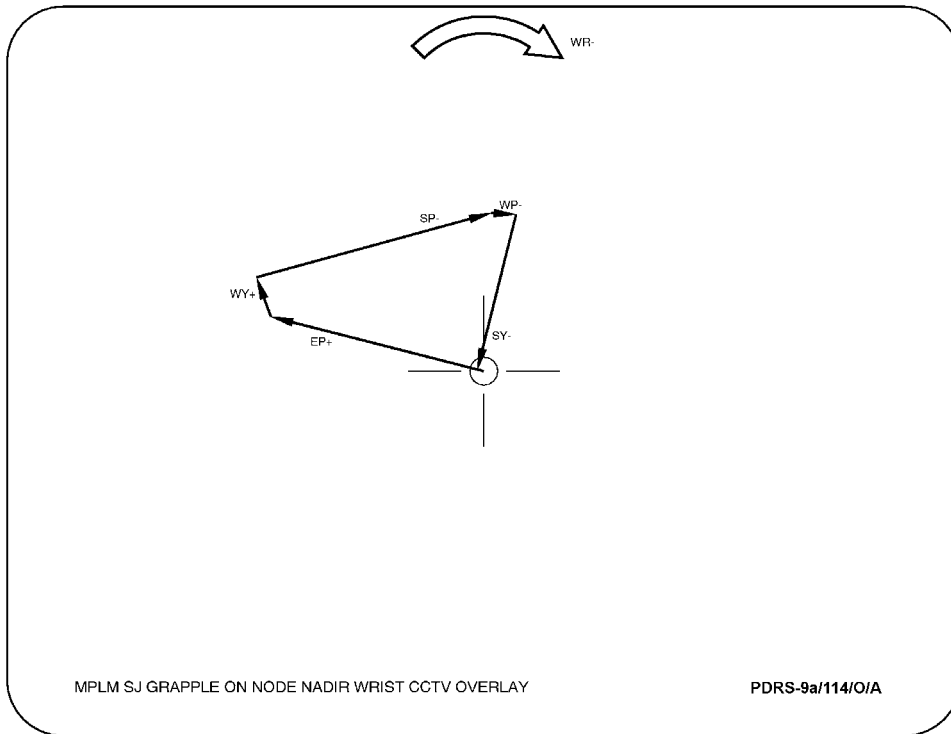

4. MPLM SJ GRAPPLE ON NODE NADIR

CAUTION
Monitor EE tb timing to prevent EE motor burnout

EE MODE – AUTO (if available)
CAPTURE sw – depress (mom)

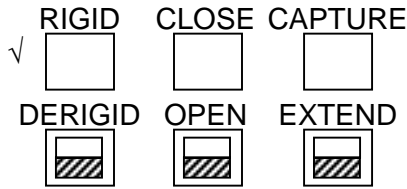

CRITICAL TIMES (28 sec total):
CAPTURE tb – gray, then
CLOSE tb – gray, 3 sec max, then
RIGID tb – gray, 25 sec max

- * If manual grapple reqd: *
- * EE MODE – MAN *
- * CAPTURE sw – depress (hold until CLOSE tb-gray, *
- 3 sec max) *
- * MAN CONTR – RIGID (hold until RIGID tb-gray, *
- 25 sec max) *

EE MODE – OFF

- * If EE limping not available: *
- * ✓BRAKES – OFF (tb-OFF) *
- * MODE – TEST, ENTER ('CNTL ERR' msg may occur) *
- * Wait 5 sec *

BRAKES – ON (tb-ON)
MODE – not DIRECT

SM 94 PDRS CONTROL
PL ID – ITEM 3 +2 EXEC
INIT ID – ITEM 24 +2 EXEC

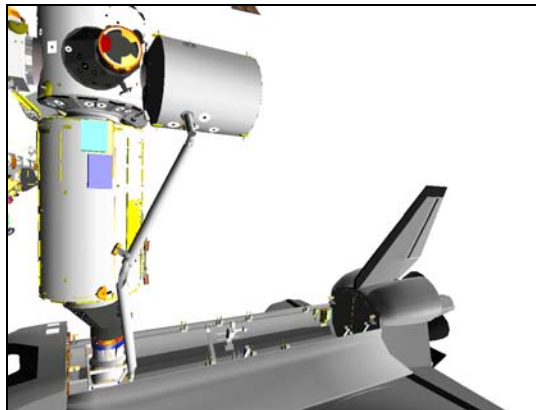

Record POS/ATT and Joint Angles:

	X	Y	Z	PITCH	YAW	ROLL	PL ID
							2
	SY	SP	EP	WP	WY	WR	
Expected	-58.2	+107.3	-77.3	+5.0	-27.5	-83.0	

Review GENERIC END EFFECTOR CUE CARD

MPLM SJ UNINSTALL (CONTINGENCY)

1. SETUP

√1.509 NODE 1 CBM DEMATE, step 9 (SODF: S&M: NOMINAL: CBM) complete

CCTV – config for uninstall

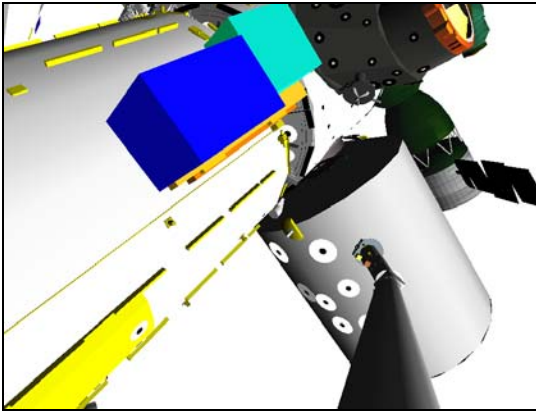

ELBOW (-10,6)

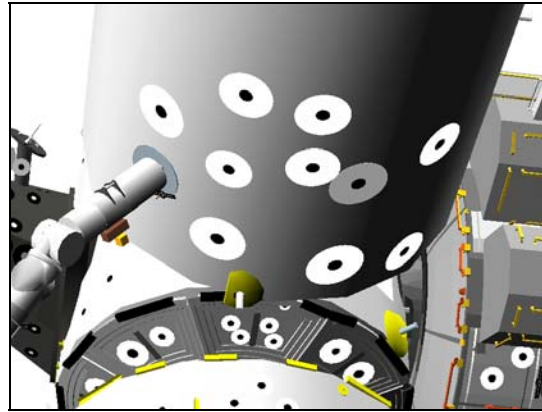

CCTV B (5,40)

- PCS
- ### 2. SJ MNVR TO CLEAR CBM GUIDES
- MCS: MCS Configuration: US GNC Inhibits
US GNC Inhibits

√Desat Request – Inh

SM 94 PDRS CONTROL

√PL ID, ITEM 3: 2

√INIT ID, ITEM 24: 2

RATE – VERN (RATE MIN tb-ON)

BRAKES – OFF (tb-OFF)

MODE – best available

Drive joints per MPLM SJ CLEAR CBM GUIDES histogram to obtain desired motion until clear of guides

MPLM SJ CLEAR CBM GUIDES

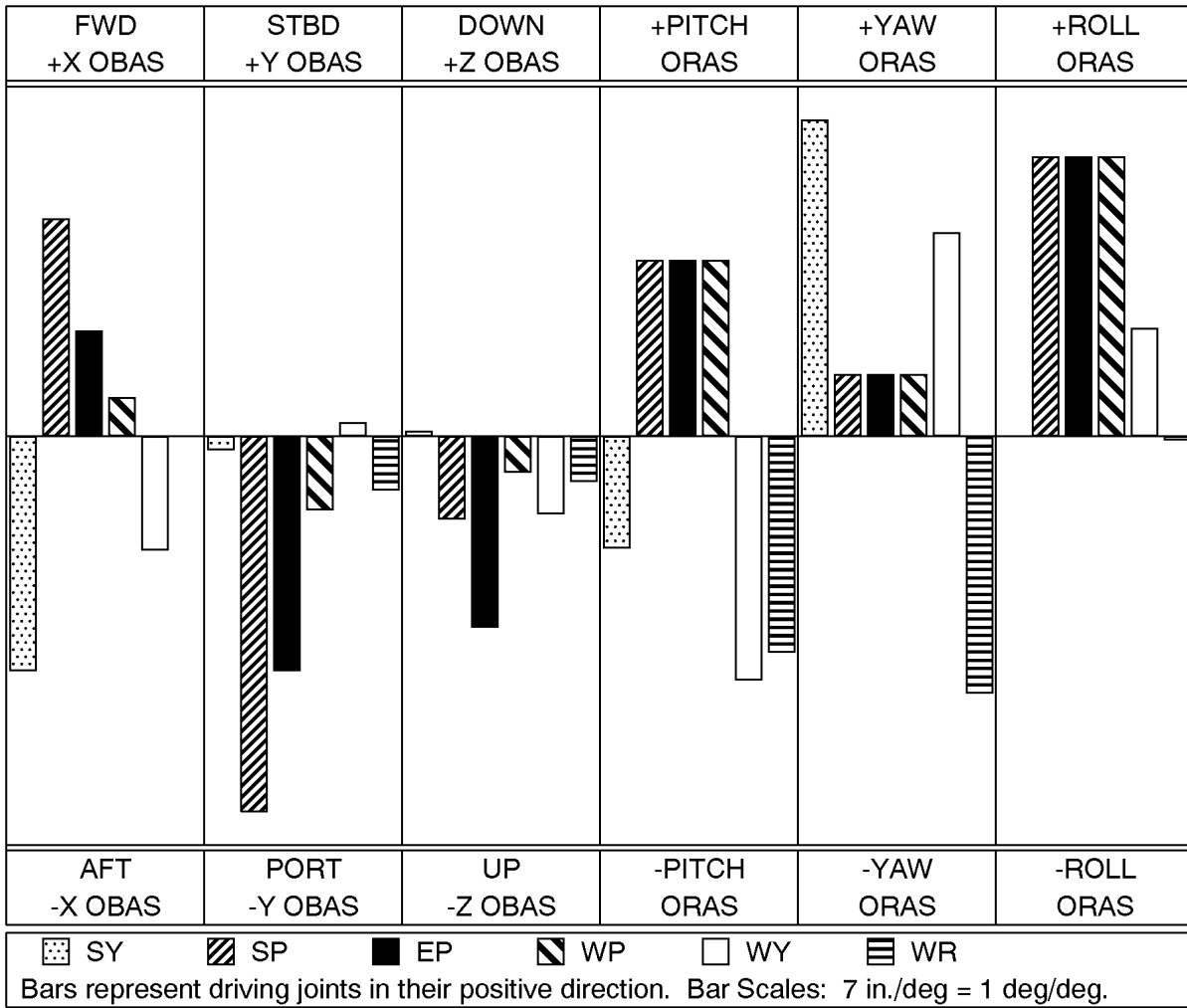

To get:	Drive:	To get:	Drive:
+X (fwd)	-SY, +SP	+PITCH	-WY, -WR
+Y (stbd)	-SP, -EP	+YAW	+SY, -WR
+Z (down)	-EP, -WY	+ROLL	+WP, +EP

Driving:	Results In:	Driving:	Results In:
+SY	-X (aft), +YAW	+WP	-Y (port), +ROLL
+SP	-Y (port), +ROLL	+WY	-X (aft), -PITCH
+EP	-Y (port), +ROLL	+WR	-Y (port), -YAW

ΔSY	ΔSP	ΔEP	ΔWP	ΔWY	ΔWR

3. SJ MNVR TO MPLM PRE-INSTALL POSN

Drive joints per MPLM UNINSTALL SJ MNVR TO PRE-INSTALL table or histogram to obtain desired motion until MPLM at Pre-Install posn

MPLM UNINSTALL SJ MNVR TO PRE-INSTALL

ΔSY	ΔSP	ΔEP	ΔWP	ΔWY	ΔWR
+8.7	-4.3	+3.0	+4.5	-7.1	+6.0

	X	SY	SP	EP	WP	WY	WR	
MPLM Install	-708	-58.2	+107.3	-77.3	+5.0	-27.5	-83.0	
	-709	-57.9	+107.2	-77.2	+5.1	-27.7	-82.8	
	-710	-57.7	+107.1	-77.2	+5.2	-27.9	-82.7	
	-711	-57.4	+107.0	-77.1	+5.4	-28.2	-82.5	
	-712	-57.1	+106.9	-77.0	+5.5	-28.4	-82.3	
	-713	-56.9	+106.8	-77.0	+5.6	-28.6	-82.1	
	-714	-56.6	+106.7	-76.9	+5.7	-28.8	-82.0	
	-715	-56.4	+106.5	-76.8	+5.8	-29.0	-81.8	
	-716	-56.1	+106.4	-76.7	+6.0	-29.2	-81.6	
	-717	-55.8	+106.3	-76.7	+6.1	-29.5	-81.5	
	-718	-55.6	+106.2	-76.6	+6.2	-29.7	-81.3	
	-719	-55.3	+106.1	-76.5	+6.3	-29.9	-81.1	
Clear of CBM Guides	-720	-55.1	+106.0	-76.4	+6.5	-30.1	-80.9	
	-722	-54.6	+105.7	-76.3	+6.7	-30.5	-80.6	
	-724	-54.1	+105.5	-76.1	+7.0	-30.9	-80.3	
	-726	-53.6	+105.3	-75.9	+7.2	-31.3	-79.9	
	-728	-53.1	+105.0	-75.8	+7.5	-31.7	-79.6	
	-730	-52.6	+104.8	-75.6	+7.7	-32.1	-79.3	
	-732	-52.2	+104.5	-75.4	+8.0	-32.5	-78.9	
	-735	-51.5	+104.2	-75.1	+8.4	-33.0	-78.4	
	-738	-50.8	+103.8	-74.9	+8.8	-33.6	-77.9	
	MPLM Pre-Install	-741	-50.1	+103.4	-74.6	+9.1	-34.1	-77.5
		-744	-49.5	+103.0	-74.3	+9.5	-34.6	-77.0

MPLM UNINSTALL SJ MNVR TO PRE-INSTALL

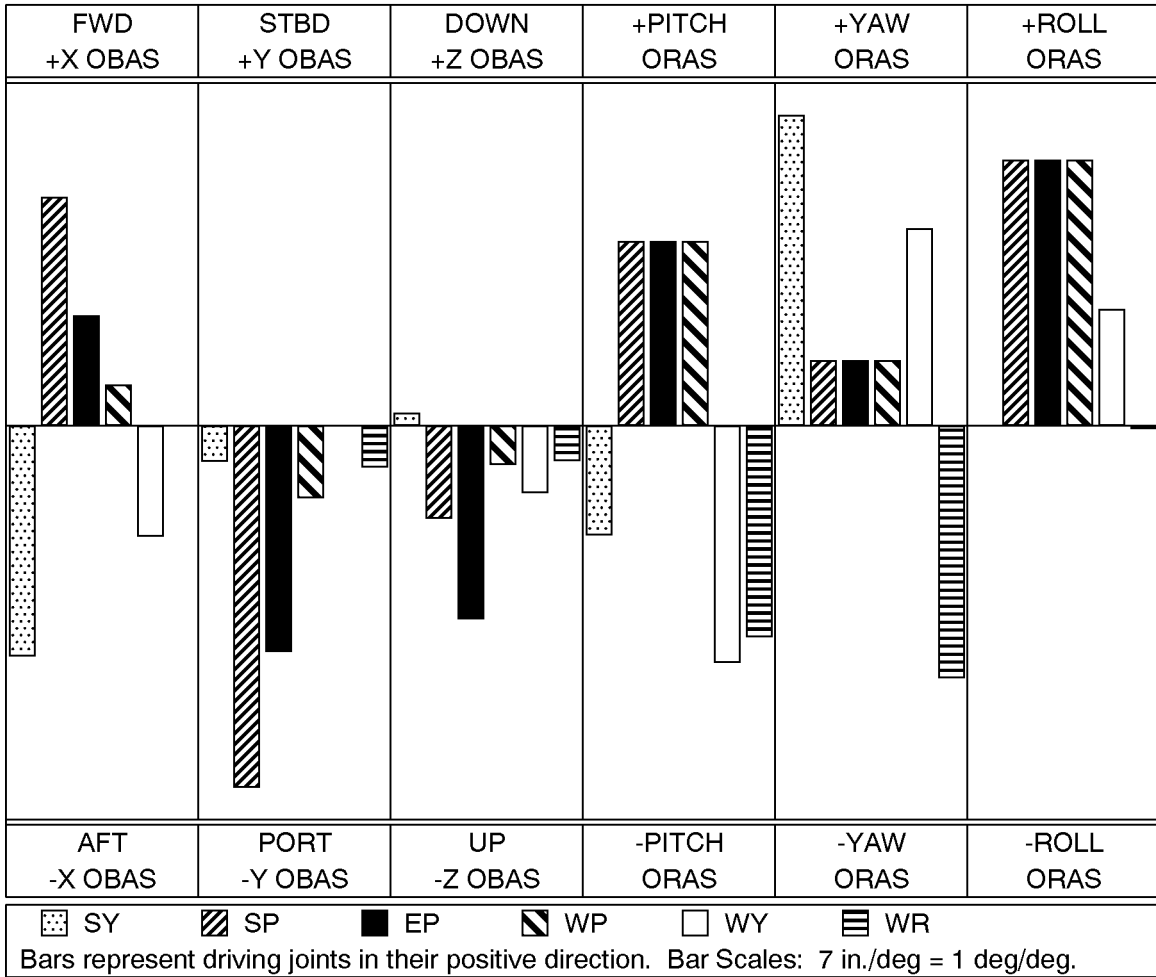

To get:	Drive:	To get:	Drive:
+X (fwd)	-SY, +SP	+PITCH	-WY, -WR
+Y (stbd)	-SP, -EP	+YAW	+SY, -WR
+Z (down)	-EP, -SP	+ROLL	+WP, +EP

Driving:	Results In:	Driving:	Results In:
+SY	-X (aft), +YAW	+WP	-Y (port), +ROLL
+SP	-Y (port), +ROLL	+WY	-X (aft), -PITCH
+EP	-Y (port), +ROLL	+WR	-Y (port), -YAW

Δ SY	Δ SP	Δ EP	Δ WP	Δ WY	Δ WR
+8.7	-4.3	+3.0	+4.5	-7.1	+6.0

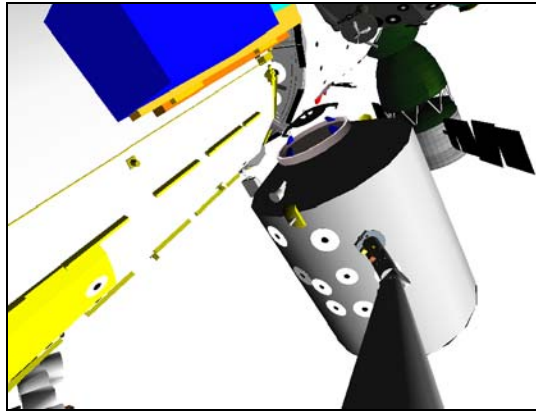

ELBOW (-10,6)

√POS/ATT and Joint Angles at MPLM PRE-INSTALL posn:

X	Y	Z	PITCH	YAW	ROLL	PL ID
-744	0	-980	1	0	0	2
SY	SP	EP	WP	WY	WR	
-49.5	+103.0	-74.3	+9.5	-34.6	-77.0	

MPLM SJ BERTH (CONTINGENCY)

1. SETUP

- CCTV – config for berth
 - install MPLM BERTH OVERLAY
 - fully zoom out for SJ pictures
 - reset PAN/TILT values for CCTV A, B, C, and D

Activate KEEL CCTV:

SSP 2

- √cb SW PWR 3 (CB2) – cl
- MPLM KEEL CAM PWR – ON
- HTR/ILLUM PWR – OFF, then ON for HI
(repeat for MED,LO,OFF)

2. SJ MNVR TO MPLM LOW HOVER POSN

- RATE – VERN (RATE MIN tb-ON)
- BRAKES – OFF (tb-OFF)
- MODE – best available

Mnvr to Low Hover posn:

Pre-Install	SY	SP	EP	WP	WY	WR	
	-49.5	+103.0	-74.3	+9.5	-34.6	-77.0	
1	-13.6						
2		+80.0					
3			-51.0				
4					-29.6		
5						-174.3	
6				-94.3			
7		+63.4					
Low Hover	-13.6	+63.4	-51.0	-94.3	-29.6	-174.3	
	X	Y	Z	PITCH	YAW	ROLL	PL ID
	-1106	0	-650	0	0	0	1
	-992	0	-636	0	0	270	2
	-1126	-3	-549	90	0	0	3

Step 1:

Drive SY+ (for 35.9°)
From -49.5 to -13.6

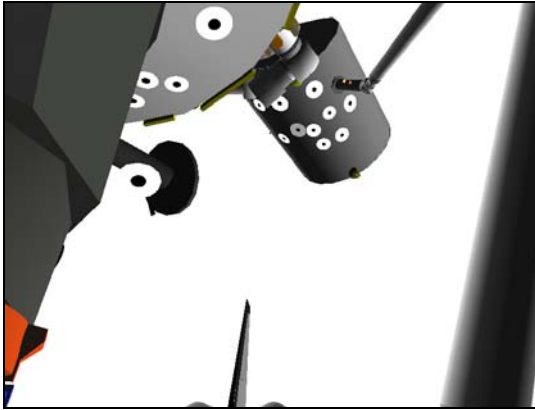

CCTV A (0,35)

Step 2:

Drive SP- (for 23.0°)
From +103.0 to +80.0

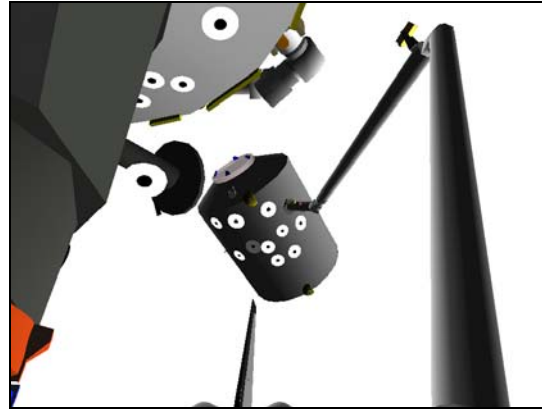

CCTV A (0,35)

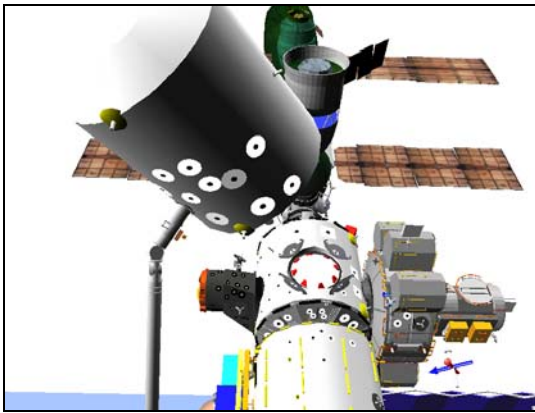

CCTV B (2,48)

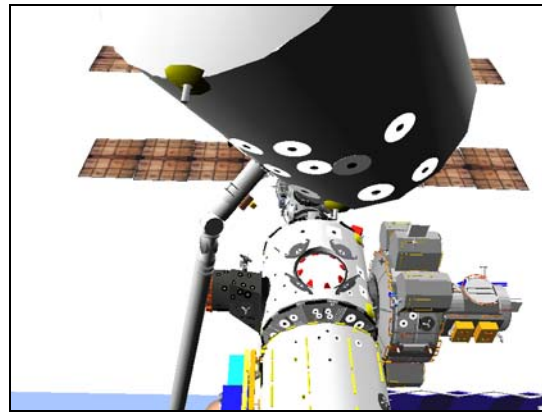

CCTV B (2,48)

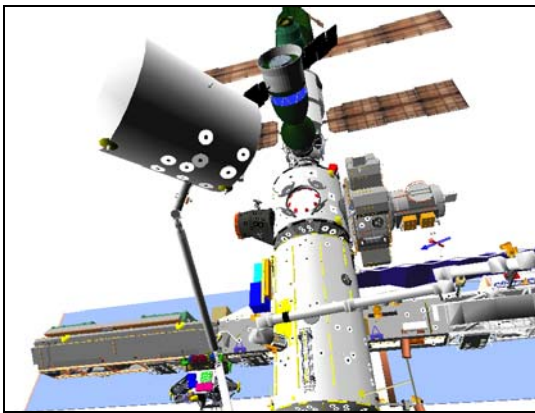

CCTV C (-15,40)

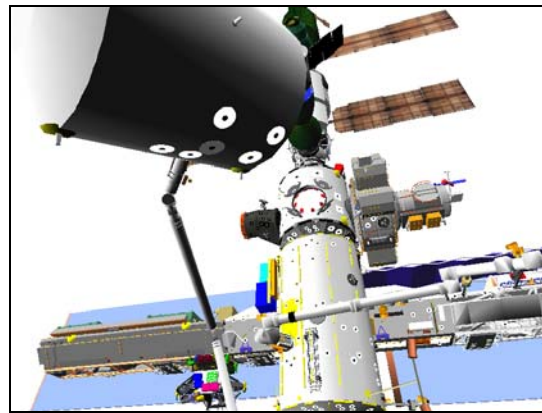

CCTV C (-15,40)

Step 3:

Drive EP+ (for 23.3°)
From -74.3 to -51.0

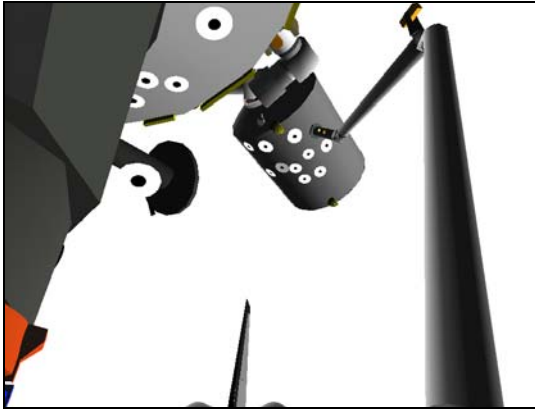

CCTV A (0,35)

Step 4:

Drive WY+ (for 5.0°)
From -34.6 to -29.6

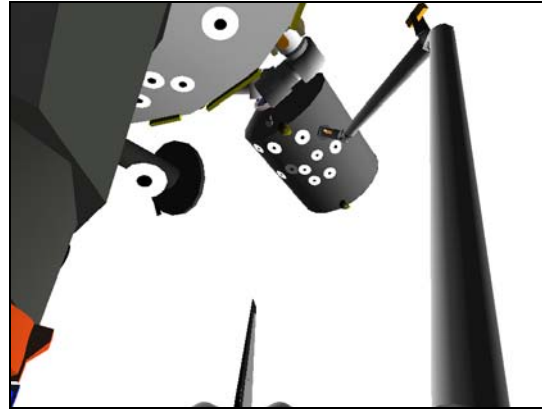

CCTV A (0,35)

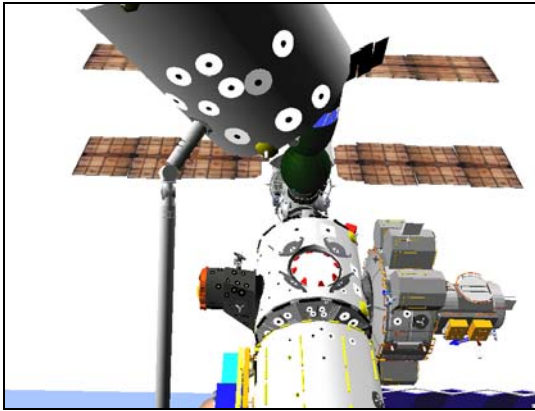

CCTV B (2,48)

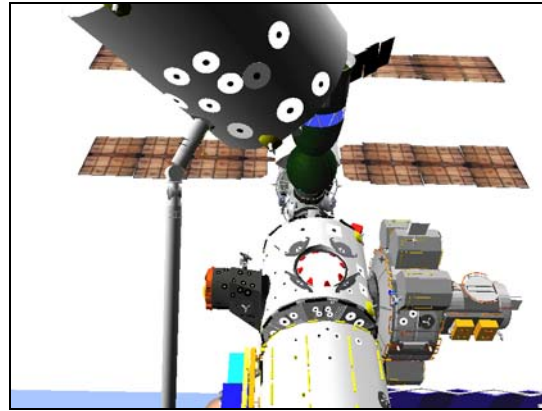

CCTV B (2,48)

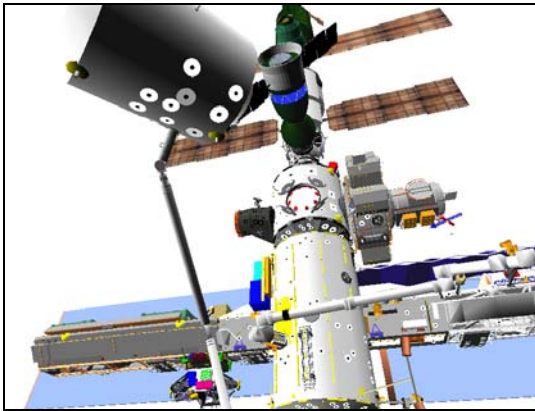

CCTV C (-15,40)

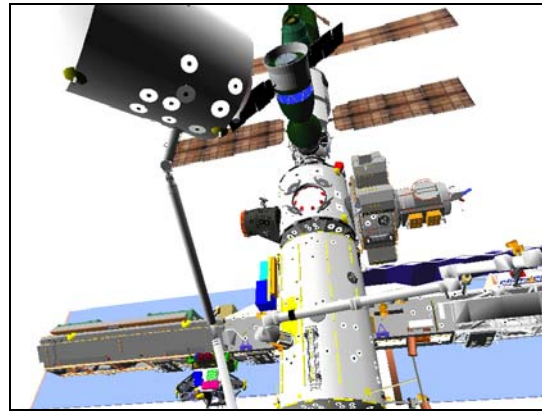

CCTV C (-15,40)

Step 5:

Drive WR- (for 97.3°)
From -77.0 to -174.3

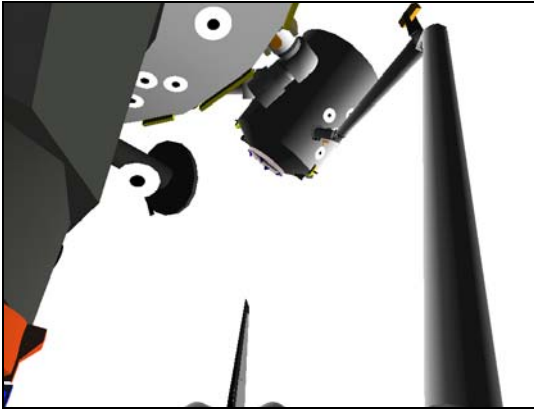

CCTV A (0,35)

Step 6:

Drive WP- (for 103.8°)
From +9.5 to -94.3

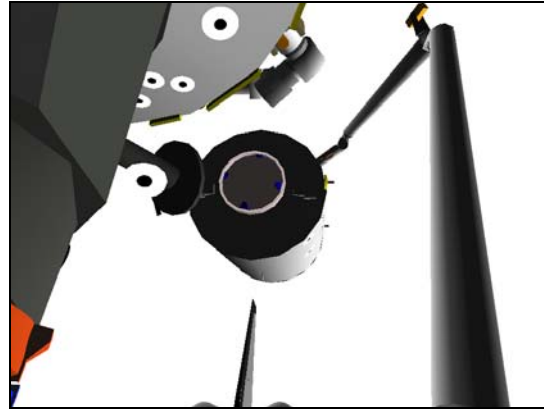

CCTV A (0,35)

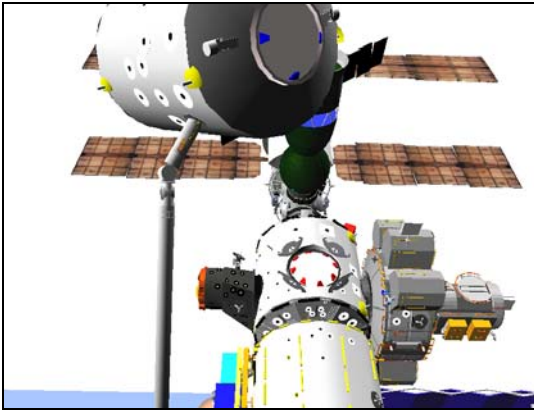

CCTV B (2,48)

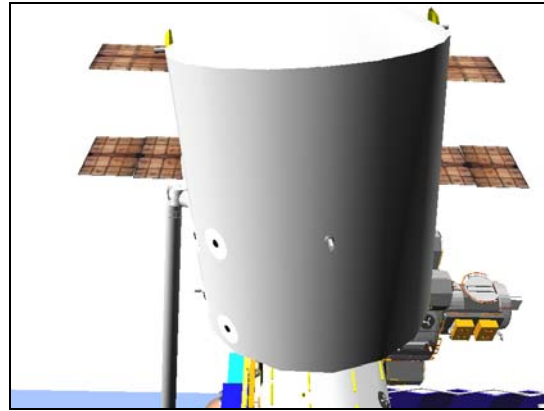

CCTV B (2,48)

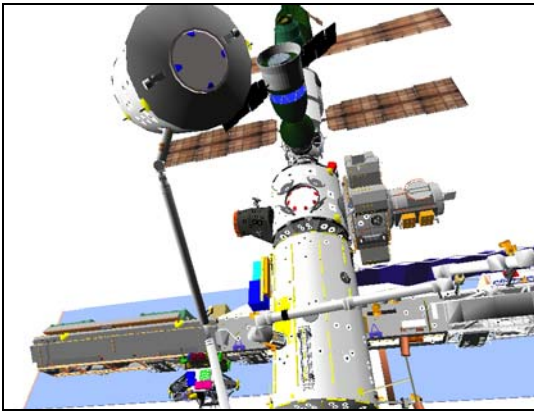

CCTV C (-15,40)

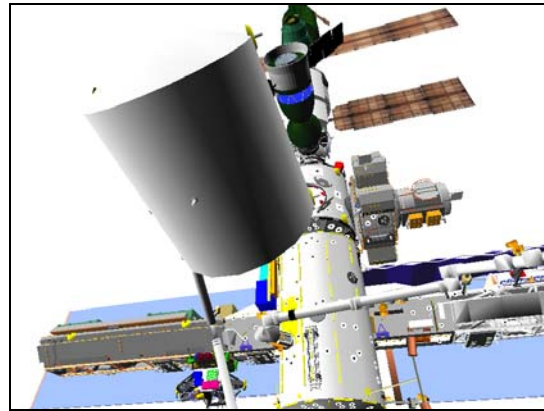

CCTV C (-15,40)

Step 7:

Drive SP- (for 16.6)

From +80.0 to +63.4

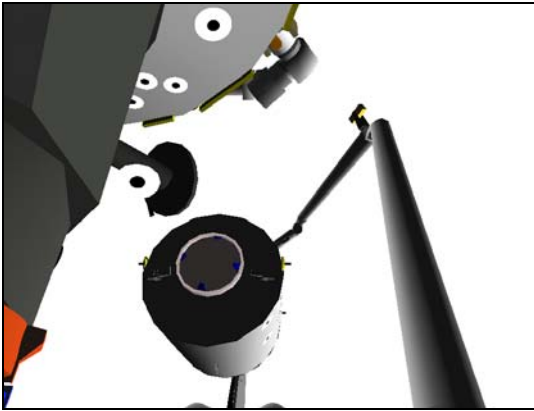

CCTV A (0,35)



CCTV B (2,48)

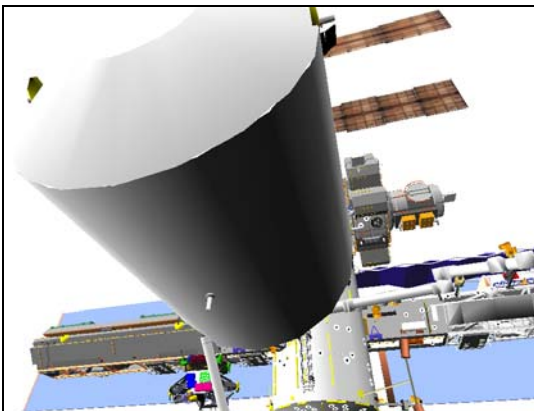

CCTV C (-15,40)

PCS 3. SJ MNVR TO TOP OF GUIDES
MCS: MCS Configuration: US GNC Inhibits
US GNC Inhibits

√Desat Request – Inh

A7U CCTV – config for berth

SM 94 PDRS CONTROL
PL ID – ITEM 3 +1(3) EXEC
INIT ID – ITEM 24 +1(3) EXEC

RATE – VERN (RATE MIN tb-ON)
BRAKES – OFF (tb-OFF)
MODE – best available

NOTE

Monitor clearance between MPLM and LMC

Drive joints per MPLM SJ MNVR TO TOP OF GUIDES histogram or table to obtain desired motion until MPLM at top of V-guides

MPLM SJ MNVR TO TOP OF GUIDES

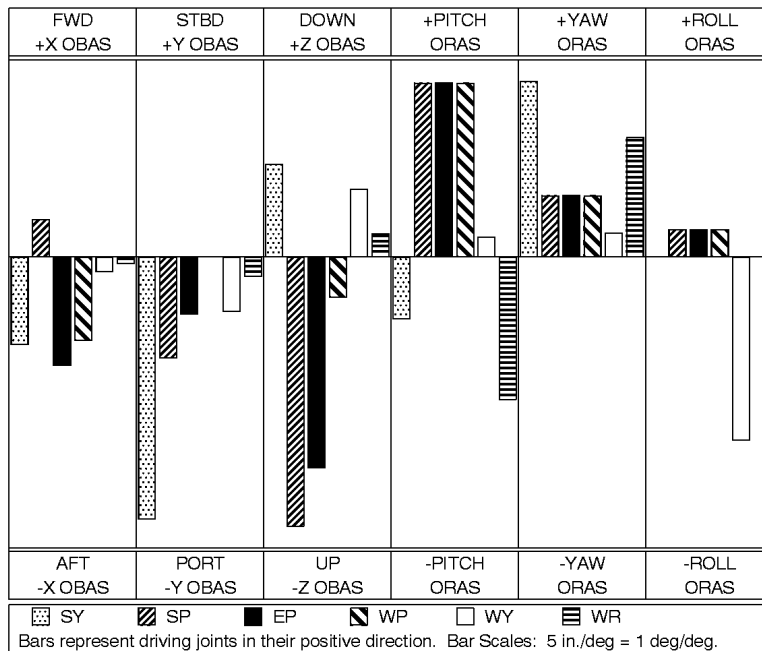

To get:	Drive:	To get:	Drive:
+X (fwd)	-EP, -WP	+PITCH	+WP, -WR
+Y (stbd)	-SY, -SP	+YAW	+SY, +WR
+Z (down)	-SP, -EP	+ROLL	-WY

Driving:	Results In:	Driving:	Results In:
+SY	-Y (port), +YAW	+WP	-X (aft), +PITCH
+SP	-Z (up), +PITCH	+WY	+Z (down), -ROLL
+EP	-Z (up), +PITCH	+WR	+Z (down), -PITCH

Δ SY	Δ SP	Δ EP	Δ WP	Δ WY	Δ WR
+10.4	-3.6	-36.9	+34.4	-0.9	-11.9

MPLM SJ MNVR TO TOP OF GUIDES

Δ SY	Δ SP	Δ EP	Δ WP	Δ WY	Δ WR
+10.4	-3.6	-36.9	+34.4	-0.9	-11.9

	Z*	SY	SP	EP	WP	WY	WR
MPLM Low Hover	-650	-13.6	+63.4	-51.0	-94.3	-29.6	-174.3
	-643	-13.3	+64.0	-53.3	-92.8	-29.6	-174.7
	-636	-12.9	+64.5	-55.4	-91.4	-29.7	-175.1
	-629	-12.6	+64.9	-57.4	-90.0	-29.7	-175.5
	-619	-12.1	+65.5	-60.1	-88.1	-29.8	-176.0
	-609	-11.6	+65.9	-62.6	-86.3	-29.9	-176.5
	-599	-11.1	+66.2	-64.9	-84.5	-29.9	-177.1
	-589	-10.7	+66.4	-67.2	-82.8	-30.0	-177.7
	-579	-10.2	+66.5	-69.2	-81.1	-30.0	-178.2
	-569	-9.7	+66.5	-71.2	-79.4	-30.1	-178.8
	-559	-9.2	+66.4	-73.1	-77.8	-30.1	-179.3
	-549	-8.7	+66.3	-74.8	-76.2	-30.2	-179.9
	-539	-8.2	+66.0	-76.5	-74.6	-30.2	-180.5
	-529	-7.7	+65.7	-78.0	-73.1	-30.2	-181.0
	-519	-7.2	+65.4	-79.5	-71.5	-30.3	-181.6
	-509	-6.7	+64.9	-80.8	-70.0	-30.3	-182.2
	-499	-6.2	+64.4	-82.1	-68.5	-30.4	-182.7
	-494	-6.0	+64.1	-82.7	-67.8	-30.4	-183.0
	-489	-5.7	+63.8	-83.3	-67.0	-30.4	-183.3
	-484	-5.5	+63.5	-83.8	-66.3	-30.4	-183.6
	-479	-5.2	+63.1	-84.4	-65.6	-30.4	-183.9
	-474	-5.0	+62.8	-84.9	-64.9	-30.4	-184.2
	-469	-4.7	+62.4	-85.4	-64.1	-30.4	-184.5
	-464	-4.5	+62.0	-85.8	-63.4	-30.5	-184.7
	-459	-4.2	+61.6	-86.3	-62.7	-30.5	-185.0
	-454	-4.0	+61.2	-86.7	-62.0	-30.5	-185.3
	-449	-3.7	+60.7	-87.1	-61.3	-30.5	-185.6
	-444	-3.5	+60.3	-87.5	-60.6	-30.5	-185.9
Top of Guides	-439	-3.2	+59.8	-87.9	-59.9	-30.5	-186.2

* Z values referenced to PL ID 1

A6U

- 4. SJ MPLM BERTH
- √PL RETEN PL SEL – 1
- √RDY 1,2,3,4,5 tb (five) – bp

Drive joints per MPLM SJ BERTH histogram to berth MPLM

MPLM Berthed posn (Insert PL ID 1 and 3 data from MPLM GRAPPLE IN BAY):

X	Y	Z	PITCH	YAW	ROLL	PL ID
						1
						3
SY	SP	EP	WP	WY	WR	

NOTE

Wait until PRLAs latched before applying brakes

MPLM SJ BERTH

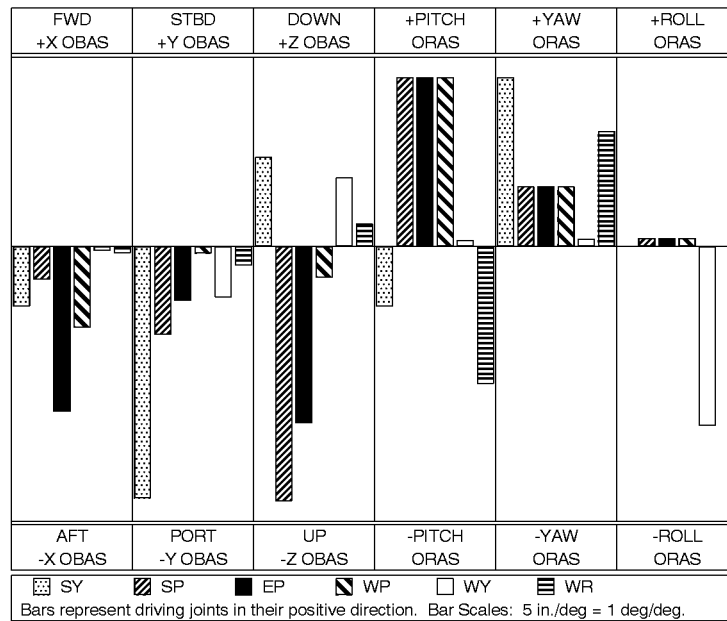

To get:	Drive:	To get:	Drive:
+X (fwd)	-EP, -WP	+PITCH	+WP, -WR
+Y (stbd)	-SY	+YAW	+SY, +WR
+Z (down)	-SP, -EP	+ROLL	-WY

Driving:	Results In:	Driving:	Results In:
+SY	-Y (port), +YAW	+WP	-X (aft), +PITCH
+SP	-Z (up), +PITCH	+WY	+Z (down), -ROLL
+EP	-Z (up), +PITCH	+WR	+Z (down), -PITCH

ΔSY	ΔSP	ΔEP	ΔWP	ΔWY	ΔWR
+1.2	-2.6	-1.5	+3.4	-0.1	-1.5

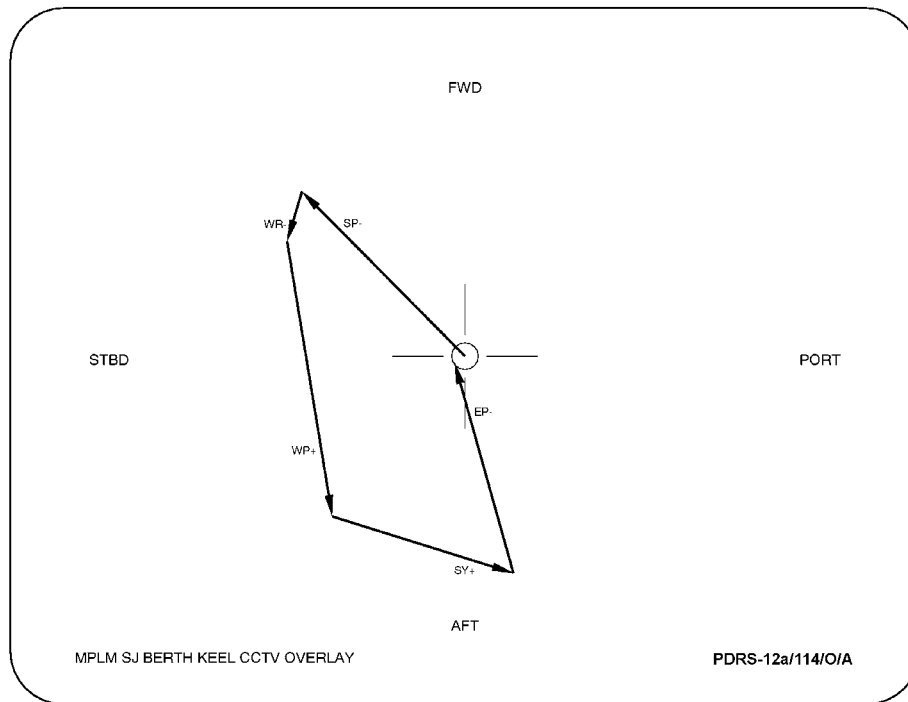

- A6U
- When vertical translation complete,
 √PL RETEN PL SEL – 1
 √RDY 1,2,3,4 tb (four) – gray
 √LAT 1,2,3,4 tb (four) – REL

SM 97 PL RETENTION

- √RDY-FOR-LAT 1,2,3,4 (eight): 1
 √LAT 1,2,3,4,5 (ten): 0

- * If any LAT msw shows '1', expect *
- * single motor time (60 sec) *

5. ACTIVATE LATCHES
 Go to MPLM BERTH, steps 3 thru 6 (NOM MPLM BERTH (CONT))

MPLM SJ UNGRAPPLE IN BAY (CONTINGENCY)

- A7U 1. SETUP
 CCTV A,B monitor the EE/grapple fixture interface
 RMS WRIST – zoom 34.0 HFOV
 – focus 5 ft

SM 94 PDRS CONTROL

PL ID – ITEM 3 +0 EXEC
 INIT ID – ITEM 24 +0 EXEC







2. MPLM UNGRAPPLE

MON 1	EE (Elbow)
MON 2	A, Mux A/B (B)

RATE – VERN (RATE MIN tb-ON) within 10 ft
 BRAKES – OFF (tb-OFF)
 MODE – best available

CAUTION
 Monitor EE tb timing to prevent EE motor burnout







EE MODE – MAN
 MAN CONTR – DERIGID (hold until DERIGID tb-gray, 5 sec max)
 RELEASE sw – depress (hold until OPEN tb-gray, 3 sec max)

RIGID	CLOSE	CAPTURE	<u>CRITICAL TIMES (28 sec total):</u> DERIGID tb – gray, 5 sec max, then OPEN tb – gray, 3 sec max
✓ 			
DERIGID	OPEN	EXTEND	
			

3. MNVR ARM CLEAR OF MPLM

Drive joints per MPLM SJ UNGRAPPLE IN BAY WRIST CCTV OVERLAY
 and EE clear of grapple fixture

EE MAN CONTR – DERIGID (hold until EXTEND tb-gray, 20 sec max)
 MODE – OFF

RIGID	CLOSE	CAPTURE	<u>CRITICAL TIMES (20 sec total):</u> EXTEND tb – gray, 20 sec max
✓ 			
DERIGID	OPEN	EXTEND	
			

BRAKES – ON (tb-ON)
 MODE – not DIRECT
 JOINT – CRIT TEMP

MPLM SJ UNGRAPPLE IN BAY

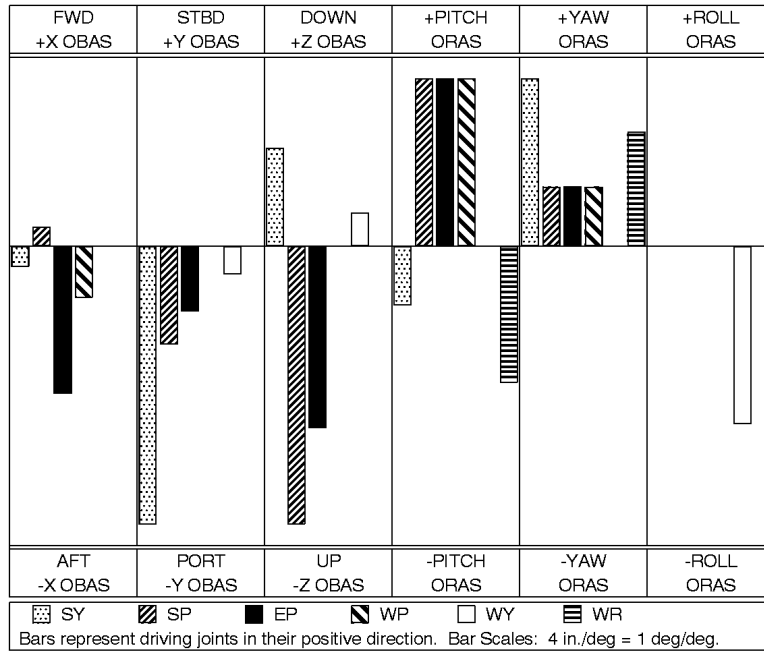

To get:	Drive:	To get:	Drive:
+X (fwd)	-EP, -WP	+PITCH	+WP, -WR
+Y (stbd)	-SY	+YAW	+SY, +WR
+Z (down)	-SP, -EP	+ROLL	-WY

Driving:	Results In:	Driving:	Results In:
+SY	-Y (port), +YAW	+WP	-X (aft), +PITCH
+SP	-Z (up), +PITCH	+WY	+Z (down), -ROLL
+EP	-Z (up), +PITCH	+WR	-PITCH

ΔSY	ΔSP	ΔEP	ΔWP	ΔWY	ΔWR
+4.6	+5.0	+4.3	-11.9	+0.0	-5.4

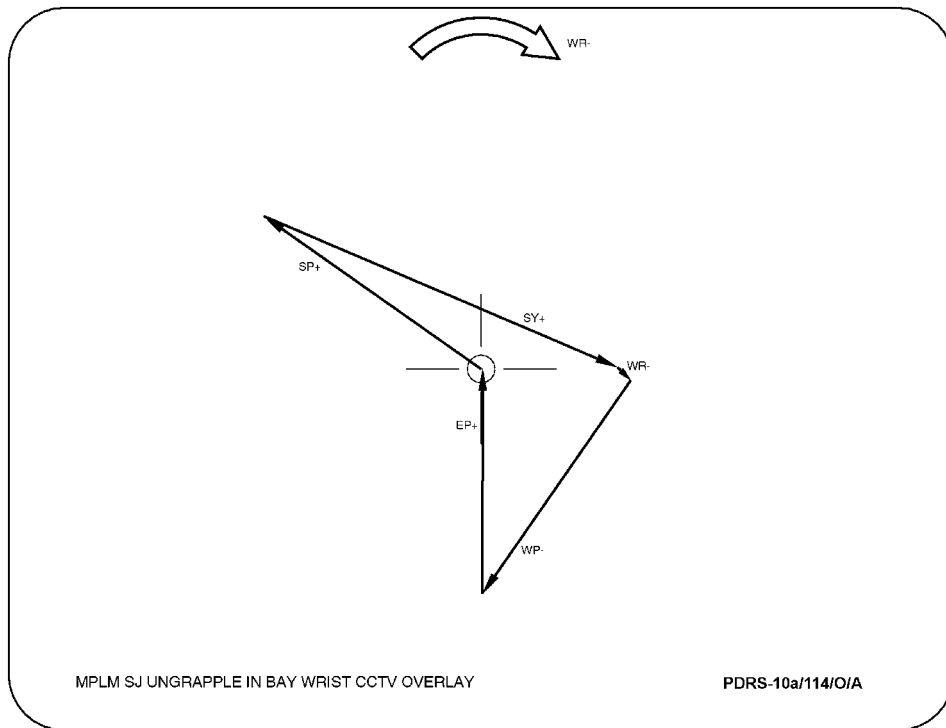

MPLM REFERENCE DATA (CONTINGENCY)

JOINT ANGLES VS POR COORDINATES (CONTINGENCY) FS 10-2
MPLM GRAPPLE IN BAY (CONTINGENCY) FS 10-2
 CLEAR V-GUIDES (CONTINGENCY)..... FS 10-2
 LOW HOVER (CONTINGENCY) FS 10-2
 HIGH HOVER (CONTINGENCY) FS 10-2
 PRE-INSTALL (CONTINGENCY) FS 10-3
 READY-TO-LATCH (CONTINGENCY) FS 10-3
 INSTALLED (CONTINGENCY) FS 10-3
 CLEAR CBM GUIDES (CONTINGENCY) FS 10-3
MPLM COORDINATE SYSTEM – PL ID 1 (CONTINGENCY) FS 10-4
 2 (CONTINGENCY) FS 10-5
 3 (CONTINGENCY) FS 10-6
 PRLA CONFIGURATION (CONTINGENCY) FS 10-7
NODE 1 NADIR CBM RTL CONFIG FOR MPLM (CONTINGENCY) FS 10-8
RMS/MPLM GO/NO-GO CRITERIA (CONTINGENCY) FS 10-9
SRMS/MPLM ATTITUDE CONTROL CONSTRAINTS (CONTINGENCY) FS 10-10

JOINT ANGLES VS POR COORDINATES (CONTINGENCY)

MPLM GRAPPLE IN BAY (CONTINGENCY)

SY	SP	EP	WP	WY	WR
-2.0	+57.2	-89.4	-56.5	-30.6	-187.7

X	Y	Z	PITCH	YAW	ROLL	PL ID
-1059	-69	-457	270	310	151	0
-1106	0	-414	0	0	0	1
-992	0	-400	0	0	270	2
-1126	-3	-313	90	0	0	3

MPLM CLEAR V-GUIDES (CONTINGENCY)

SY	SP	EP	WP	WY	WR
-3.2	+59.8	-87.9	-59.9	-30.5	-186.2

X	Y	Z	PITCH	YAW	ROLL	PL ID
-1059	-69	-482	270	310	151	0
-1106	0	-439	0	0	0	1
-992	0	-425	0	0	270	2
-1126	-3	-338	90	0	0	3

MPLM LOW HOVER (CONTINGENCY)

SY	SP	EP	WP	WY	WR
-13.6	+63.4	-51.0	-94.3	-29.6	-174.3

X	Y	Z	PITCH	YAW	ROLL	PL ID
-1059	-69	-693	270	310	151	0
-1106	0	-650	0	0	0	1
-992	0	-636	0	0	270	2
-1126	-3	-549	90	0	0	3

MPLM HIGH HOVER (CONTINGENCY)

SY	SP	EP	WP	WY	WR
-40.0	+94.9	-67.7	+15.6	-41.7	-69.2

X	Y	Z	PITCH	YAW	ROLL	PL ID
-864	-57	-913	91	320	331	0
-910	-14	-982	1	0	90	1
-796	0	-980	1	0	0	2
-929	87	-979	91	90	0	3

MPLM PRE-INSTALL (CONTINGENCY)

SY	SP	EP	WP	WY	WR
-49.5	+103.0	-74.3	+9.5	-34.6	-77.0

X	Y	Z	PITCH	YAW	ROLL	PL ID
-812	-57	-913	91	320	331	0
-858	-14	-982	1	0	90	1
-744	0	-980	1	0	0	2
-877	87	-980	91	90	0	3

MPLM READY-TO-LATCH (CONTINGENCY)

SY	SP	EP	WP	WY	WR
-56.9	+106.8	-77.1	+5.7	-28.6	-82.2

X	Y	Z	PITCH	YAW	ROLL	PL ID
-781	-57	-913	91	320	331	0
-827	-13	-982	1	0	90	1
-713	1	-980	1	0	0	2
-846	88	-979	91	90	0	3

MPLM INSTALLED (CONTINGENCY)

SY	SP	EP	WP	WY	WR
-58.2	+107.3	-77.3	+5.0	-27.5	-83.0

X	Y	Z	PITCH	YAW	ROLL	PL ID
-776	-57	-913	91	320	331	0
-822	-14	-982	1	0	90	1
-708	0	-980	1	0	0	2
-841	87	-980	91	90	0	3

MPLM CLEAR CBM GUIDES (CONTINGENCY)

SY	SP	EP	WP	WY	WR
-54.5	+105.7	-76.3	+6.8	-30.6	-80.5

X	Y	Z	PITCH	YAW	ROLL	PL ID
-790	-57	-913	91	320	331	0
-836	-14	-982	1	0	90	1
-722	0	-980	1	0	0	2
-855	88	-980	91	90	0	3

MPLM COORDINATE SYSTEM – PL ID 1 (CONTINGENCY)

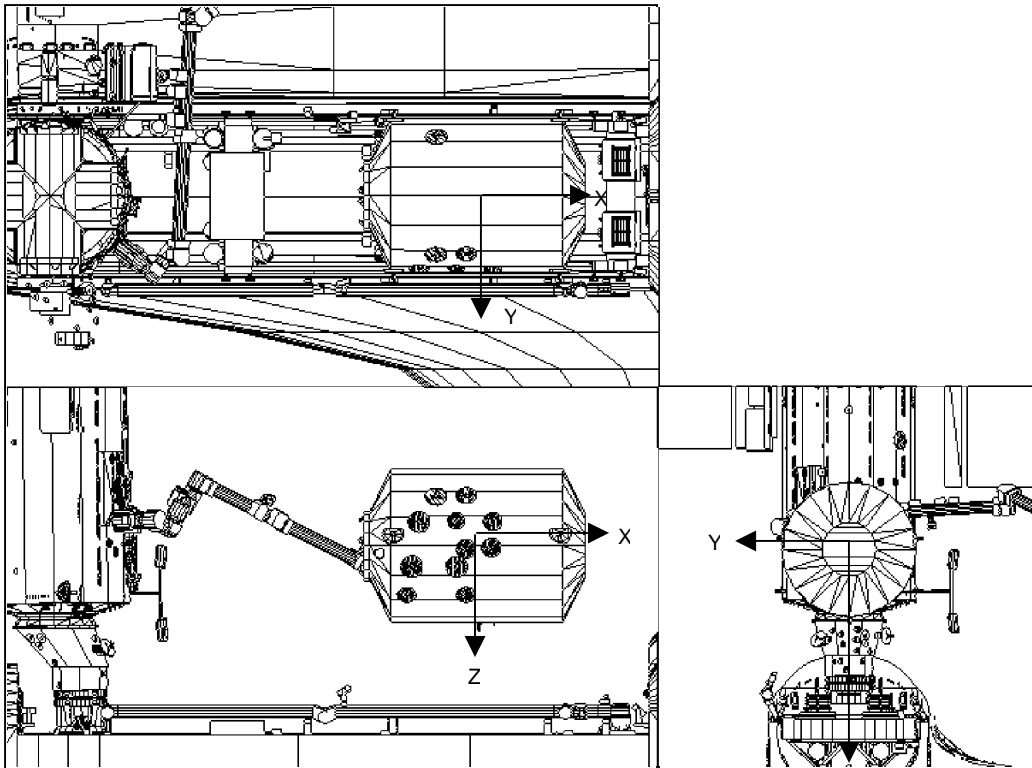

POR: POR at centerline of fwd and aft trunnions during MPLM unberth

PURPOSE: MPLM unberth from payload bay

RATES:	COARSE	VERN
TRAN LIM ft/sec	0.10	0.05
ROT LIM deg/sec	0.22	0.11

NOTE

COARSE translational and rotational rates are equal to VERN rates and VERN rates equal one half original VERN rates

MPLM COORDINATE SYSTEM – PL ID 2 (CONTINGENCY)

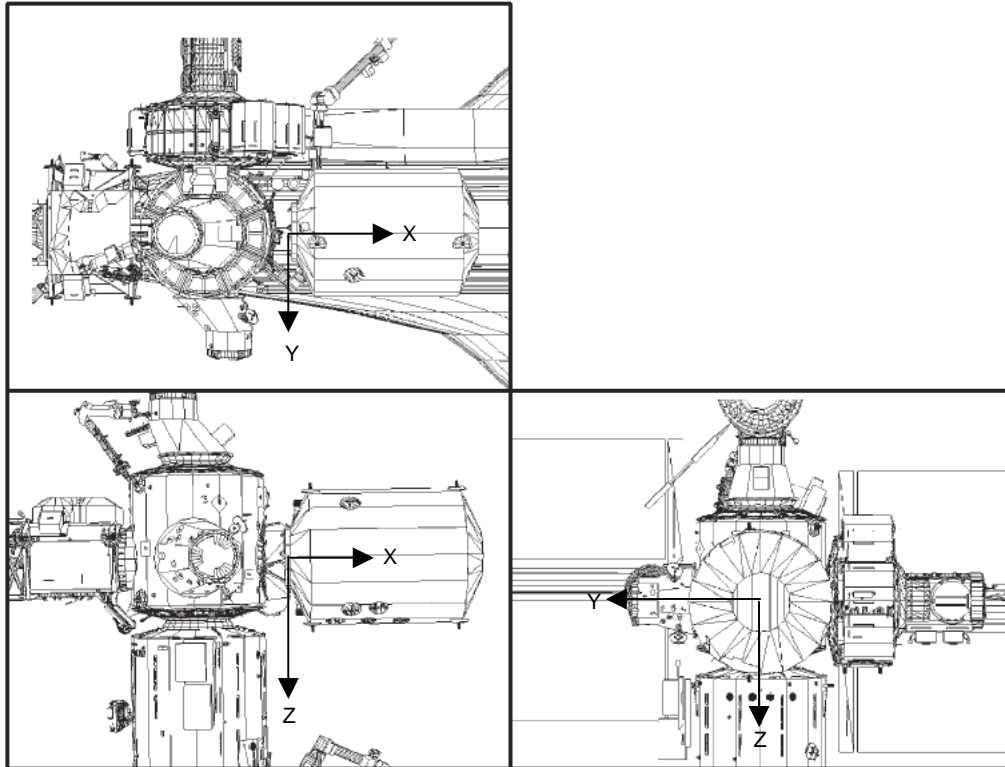

POR: POR at CBCS target and aligned with CBCS camera view out Node nadir window

PURPOSE: MPLM mate to ISS NODE 1 nadir port

RATES:	COARSE	VERN
TRAN LIM ft/sec	0.10	0.05
ROT LIM deg/sec	0.22	0.11

NOTE

COARSE translational and rotational rates are equal to VERN rates and VERN rates equal one half original VERN rates

MPLM COORDINATE SYSTEM – PL ID 3 (CONTINGENCY)

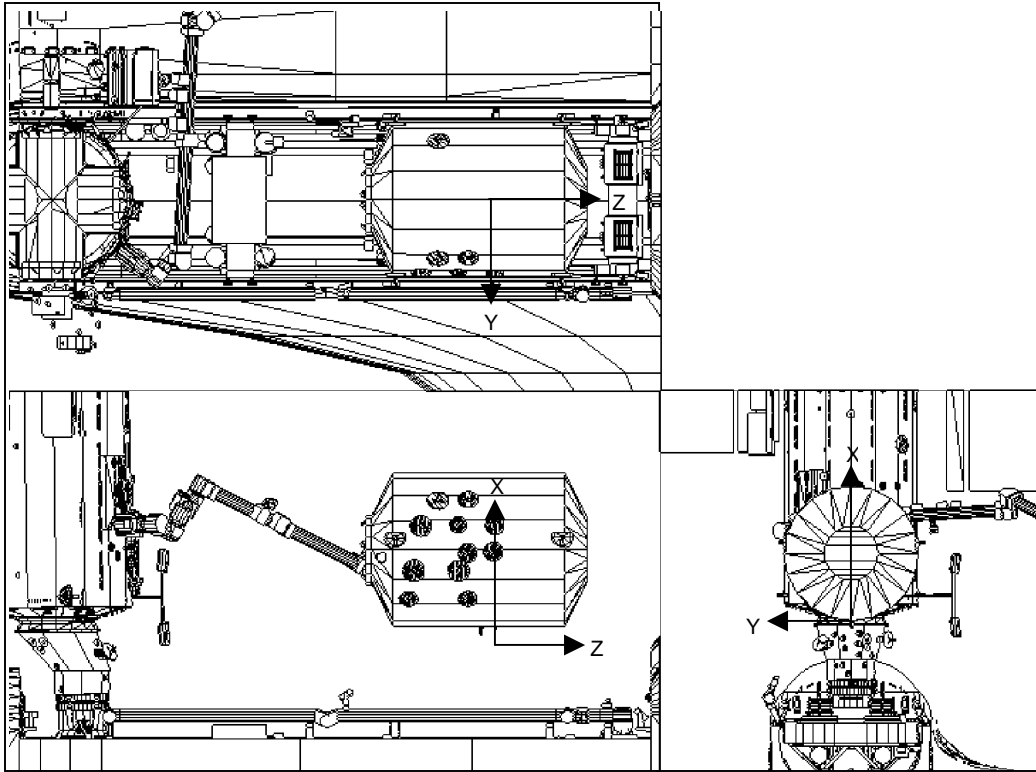

POR: POR at MPLM keel target, aligned with view from aft keel camera

PURPOSE: MPLM berth in payload bay

RATES:	COARSE	VERN
TRAN LIM ft/sec	0.10	0.05
ROT LIM deg/sec	0.22	0.11

NOTE

COARSE translational and rotational rates are equal to VERN rates and VERN rates equal one half original VERN rates

MPLM PRLA CONFIGURATION (CONTINGENCY)

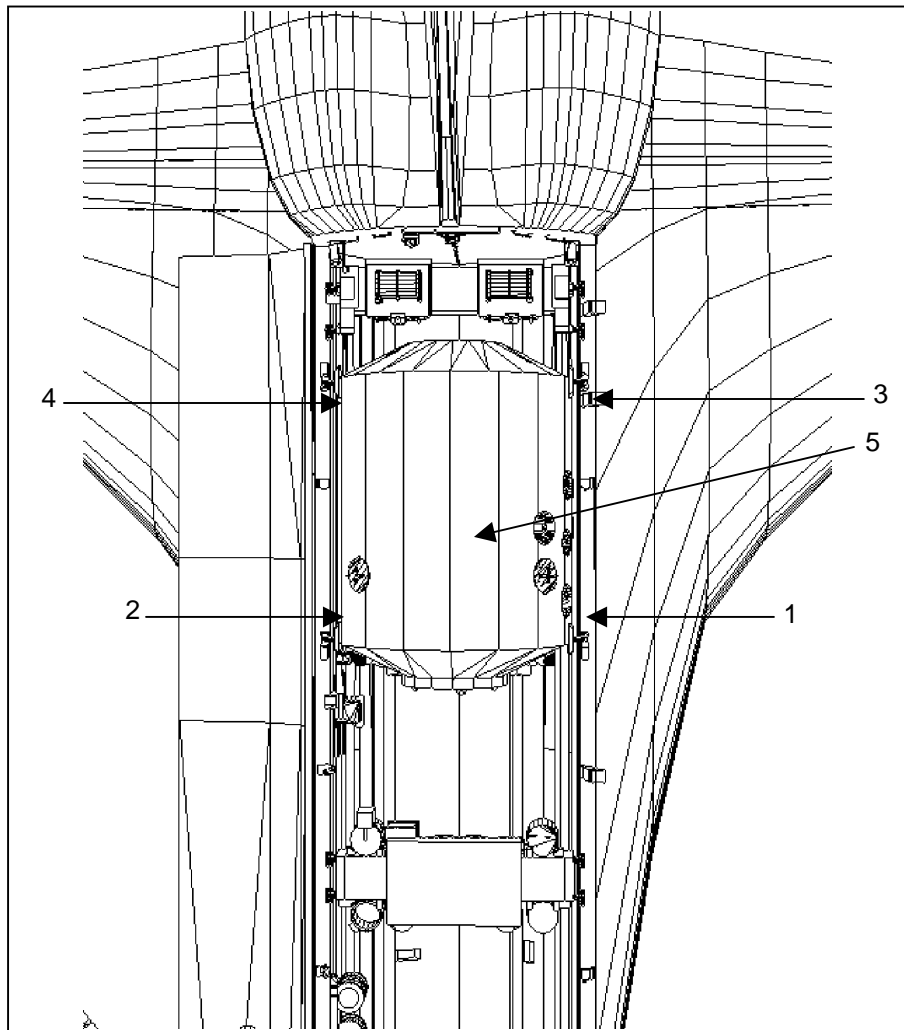

OPENING SEQUENCE	PL SEL	REL
AKA	1	5
FWD PRLA	1	1,2
AFT PRLA	1	3,4

NODE 1 NADIR CBM RTL CONFIG FOR MPLM (CONTINGENCY)

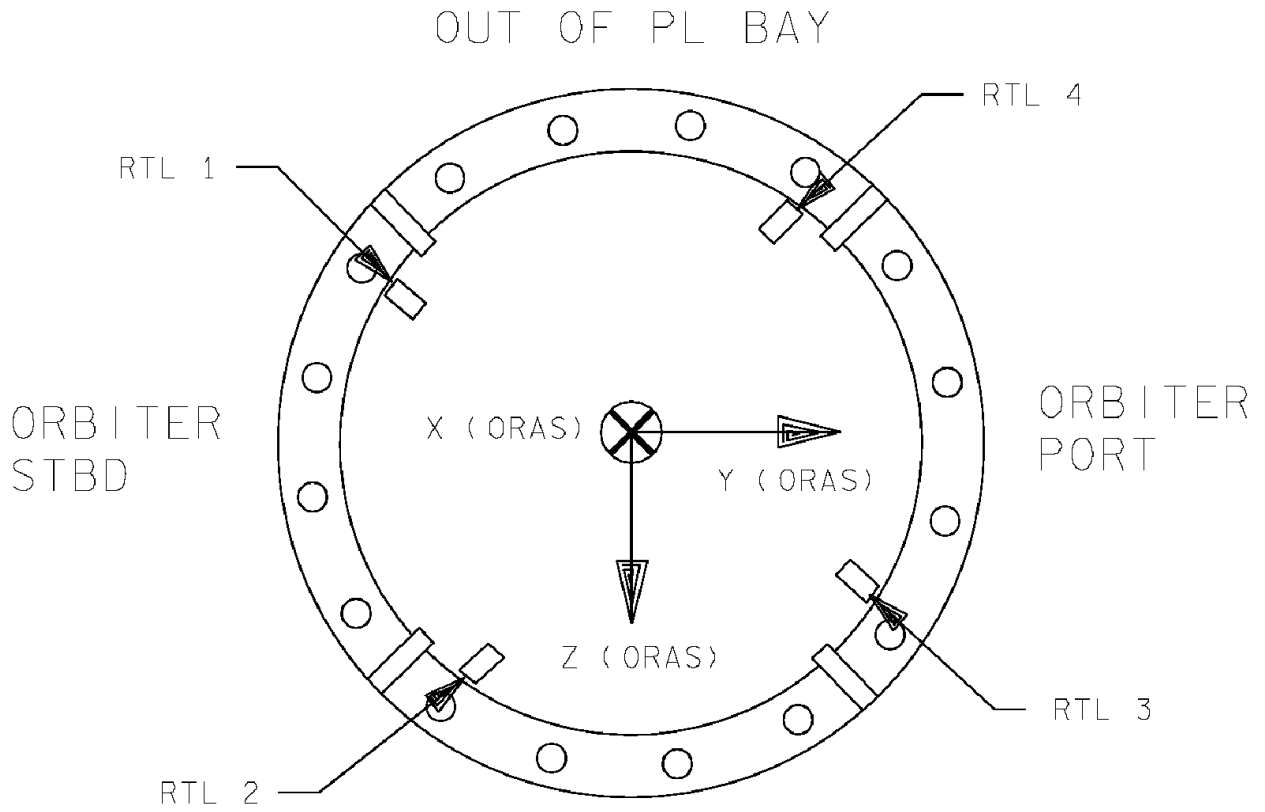

NOTE: VIEW SHOWN IS FROM NODE 1 NADIR WINDOW

RMS/MPLM GO/NO-GO CRITERIA (CONTINGENCY)

CONTINUE OPS IF:	MPLM OPERATIONS (HIGH PRIORITY)	FLT RULE REF
SHOULDER BRACE REL (1)	0 ↓ [1]	
JETTISON SYSTEM (2)	1 ↓ [2]	A12-81
MPM STOW MOTORS (2)	2 ↓ [1]	A12-72
MRL LATCH CAPABILITY (3)	3 ↓ [3]	A12-73
MPM (4) STOWED IND (8)		
MPM (4) DEPLOY IND (8)	SH 1 ↓	A12-72
MRLs LATCHED (3)		
MAN AUG MODE (1)		
SINGLE MODE (1)	3 ↓ [4]	A12-111
DIRECT MODE (1)		
BACKUP MODE (1)		
BRAKES (6)	0 ↓	A12-115
AUTO BRAKES (1)	0 ↓ [5]	A12-116
CAPTURE & RIGIDIZE (2)	1 ↓	A12-161
DERIGIDIZE (2)	2 ↓	A12-161
RELEASE (2)	2 ↓	A12-161
BACKUP RELEASE (1)		
THERMAL (DEG F) -20(0), 176(172), LED -20(0), 147(144), ABE (EE) -20(0), 110(106), ABE (SPA)	REQD	A12-3

NOTES

- [1] EVA CAPABILITY EXISTS FOR THE FOLLOWING CONTINGENCIES:
- SHOULDER BRACE RELEASE
 - MPM DEPLOY/STOW
 - RMS STRAPDOWN
 - GRAPPLE FIXTURE (GF) RELEASE
- [2] IFM IS AVAILABLE TO RECOVER JETTISON SYSTEM; HIGH PRIORITY RMS ACTIVITIES MAY CONTINUE
- [3] CONTINUE OPERATIONS EVEN IF ONE FAILURE WILL RESULT IN INABILITY TO LATCH AT LEAST TWO MRLs (ASSUMES CURRENTLY HAVE TWO-LATCH CAPABILITY). EVA CAPABILITY REQD
- [4] ONE OF SINGLE, DIRECT, OR BACKUP REQD FOR UNCRADLING
- [5] OPERATIONS CAN CONTINUE IN DIRECT OR BACKUP WITH LOSS OF AUTO BRAKES. CAPTURE CAPABILITY DOES NOT EXIST IN BACKUP

SEE FLIGHT RULE {UF-1_12C-23}, MSS REDUNDANCY REQUIREMENTS [C] FOR CONTINGENCY CASES WHERE SRMS MAY PERFORM THESE OPERATIONS IF THE SSRMS IS NO-GO

SRMS/MPLM ATTITUDE CONTROL CONSTRAINTS (CONTINGENCY)

PAYLOAD POSITIONS	STS ATTITUDE CONTROL		ISS ATTITUDE CONTROL		
	VERN	ALT	CMG-TA		THRUSTERS ONLY
			MOM MGMT OR ATT HOLD	DESAT REQ	
MANEUVERING FROM MPLM BERTHED TO LOW HOVER – CLEARANCE < 2 FT					
– CLEARANCE > 2 FT	[6]	[6]	ALLOWED	ENA	ALLOWED
AT MPLM LOW HOVER	A12	B12, LO Z	ALLOWED	ENA	ALLOWED
MANEUVERING FROM LOW HOVER TO PRE-INSTALL	[6]	[6]	ALLOWED	ENA	ALLOWED
AT MPLM PRE-INSTALL	A12	B12, LO Z	ALLOWED	ENA	ALLOWED
MANEUVERING FROM MPLM PRE-INSTALL TO MPLM INSTALL – CLEARANCE > 2 FT	[6]	[6]	ALLOWED	ENA	ALLOWED
– CLEARANCE < 2 FT			ALLOWED		
AT MPLM INSTALL AFTER CBM A-BOLTS COMPLETE	A12	B12, LO Z	ALLOWED	ENA	ALLOWED
MANEUVERING FROM MPLM PRE-INSTALL TO MPLM LOW HOVER	[6]	[6]	ALLOWED	ENA	ALLOWED
AT MPLM JETTISON	A12 [7]	B12, LO Z [7]	ALLOWED	ENA	ALLOWED

NOTES:

- [1] KEY: THRUSTER FIRING NOT ALLOWED
- [2] SRMS/PAYLOAD POSITIONS DEFINED IN REF DATA
- [3] CONSTRAINTS APPLY TO BOTH BRAKES ON AND POSITION HOLD UNLESS OTHERWISE NOTED
- [4] CONSTRAINTS NOT SHOWN IN THE TABLE ARE NOT ALLOWED
- [5] REFERENCE RULE {A12.1.1-6}, OMS/RCS CONSTRAINTS, FOR USE OF AUTOMATIC ATTITUDE CONTROL IN UNPLANNED CONTINGENCY
- [6] IF SRMS IS ALONG PLANNED TRAJECTORY WITH BRAKES ON OR POSITION HOLD, CLOSED-LOOP SHUTTLE ATTITUDE CONTROL IS PERMITTED. IN ADDITION, SRMS/MPLM MUST BE GREATER THAN 2 FT FROM STRUCTURE (5 FT FOR ALT)
- [7] REAL-TIME UPLINK REQUIRED, IF USED

CUE CARD CONFIGURATION

MPLM SJ GRAPPLE IN BAY WRIST CCTV OVERLAY	FS CC 11-2
UNGRAPPLE ON NODE NADIR WRIST CCTV OVERLAY	FS CC 11-3
GRAPPLE ON NODE NADIR WRIST CCTV OVERLAY	FS CC 11-4
UNGRAPPLE IN BAY WRIST CCTV OVERLAY	FS CC 11-5
BERTH OVERLAY	FS CC 11-6
SJ BERTH KEEL CCTV OVERLAY	FS CC 11-7
CBCS CCTV OVERLAY	FS CC 11-8
OVERLAY FOR ROEU PL SEL POSITION.....	FS CC 11-9

CUE CARD
CONFIG

Fabricate as transparency

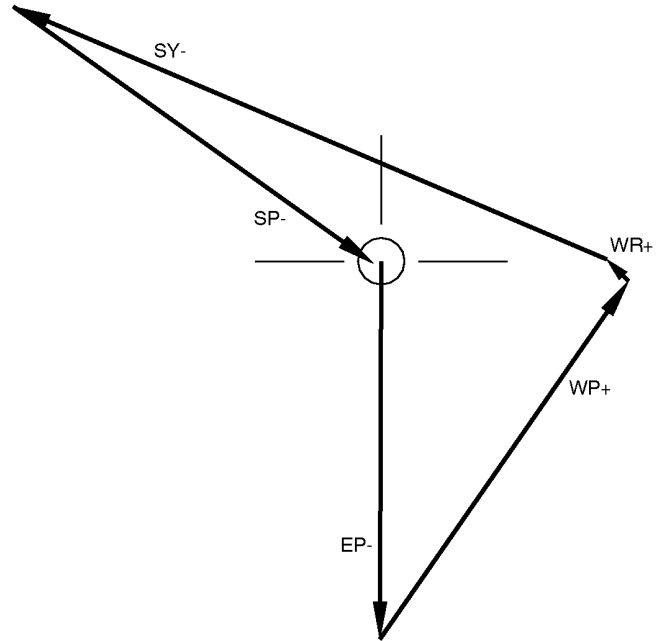

MPLM SJ GRAPPLE IN BAY WRIST CCTV OVERLAY

PDRS-7a/114/O/A

(reduced copy)

Fabricate as transparency

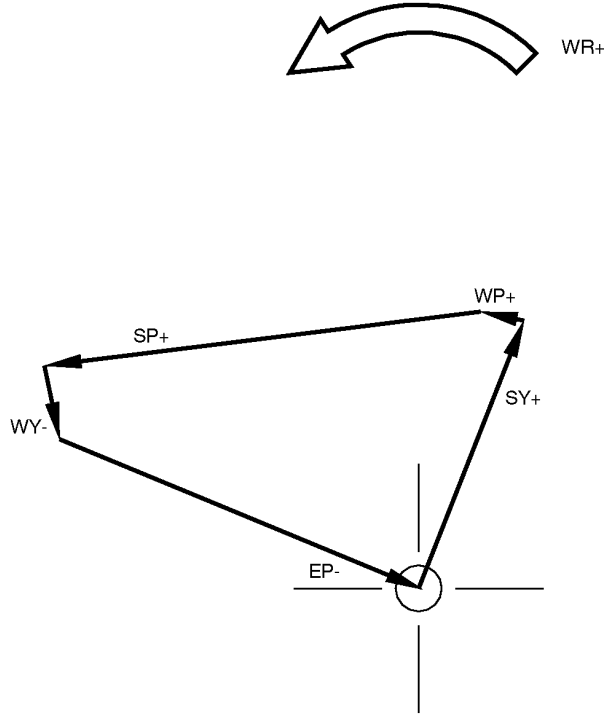

MPLM SJ UNGRAPPLE ON NODE NADIR WRIST CCTV OVERLAY

PDRS-8a/114/O/A

(reduced copy)

Fabricate as transparency

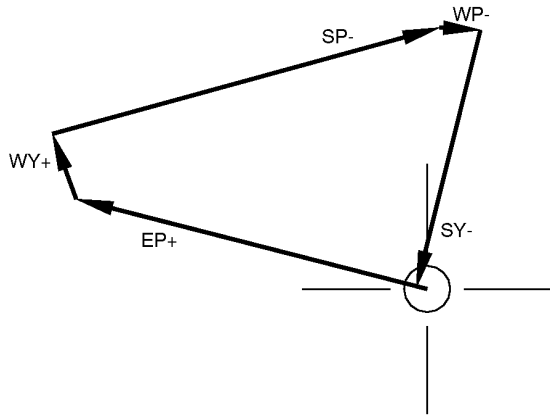

MPLM SJ GRAPPLE ON NODE NADIR WRIST CCTV OVERLAY

PDRS-9a/114/O/A

(reduced copy)

Fabricate as transparency

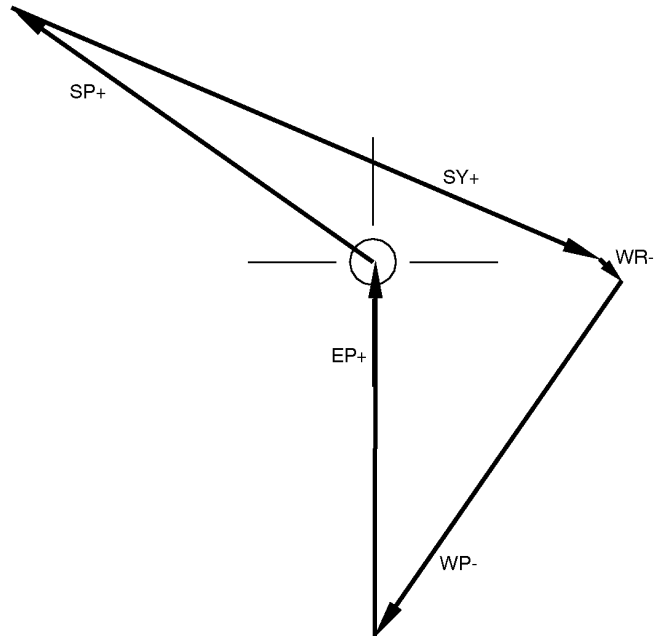

MPLM SJ UNGRAPPLE IN BAY WRIST CCTV OVERLAY

PDRS-10a/114/O/A

(reduced copy)

Fabricate as transparency

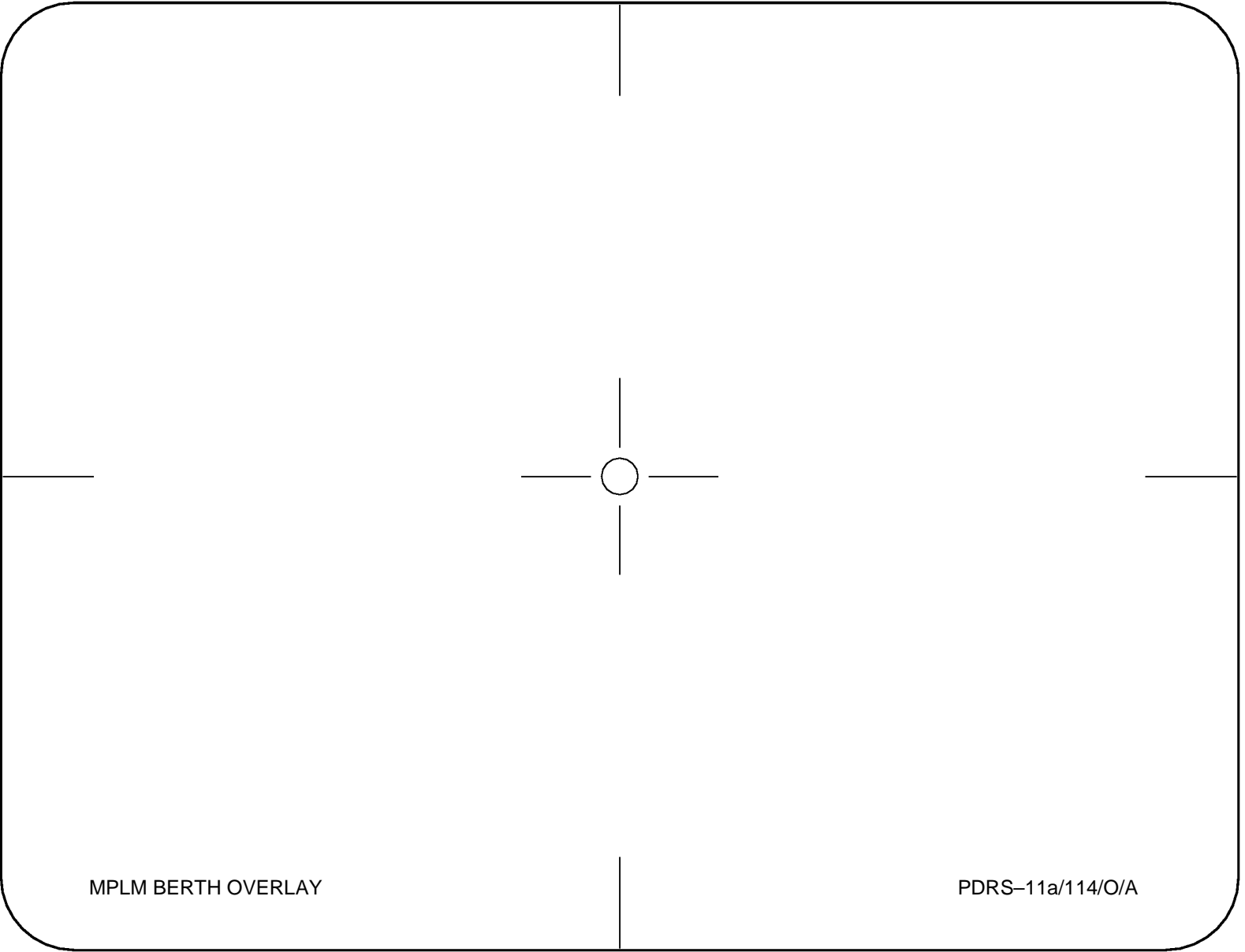

MPLM BERTH OVERLAY

PDRS-11a/114/O/A

(reduced copy)

FAB USE ONLY

FS CC 11-6

PDRS/114/BAS A

Fabricate as transparency

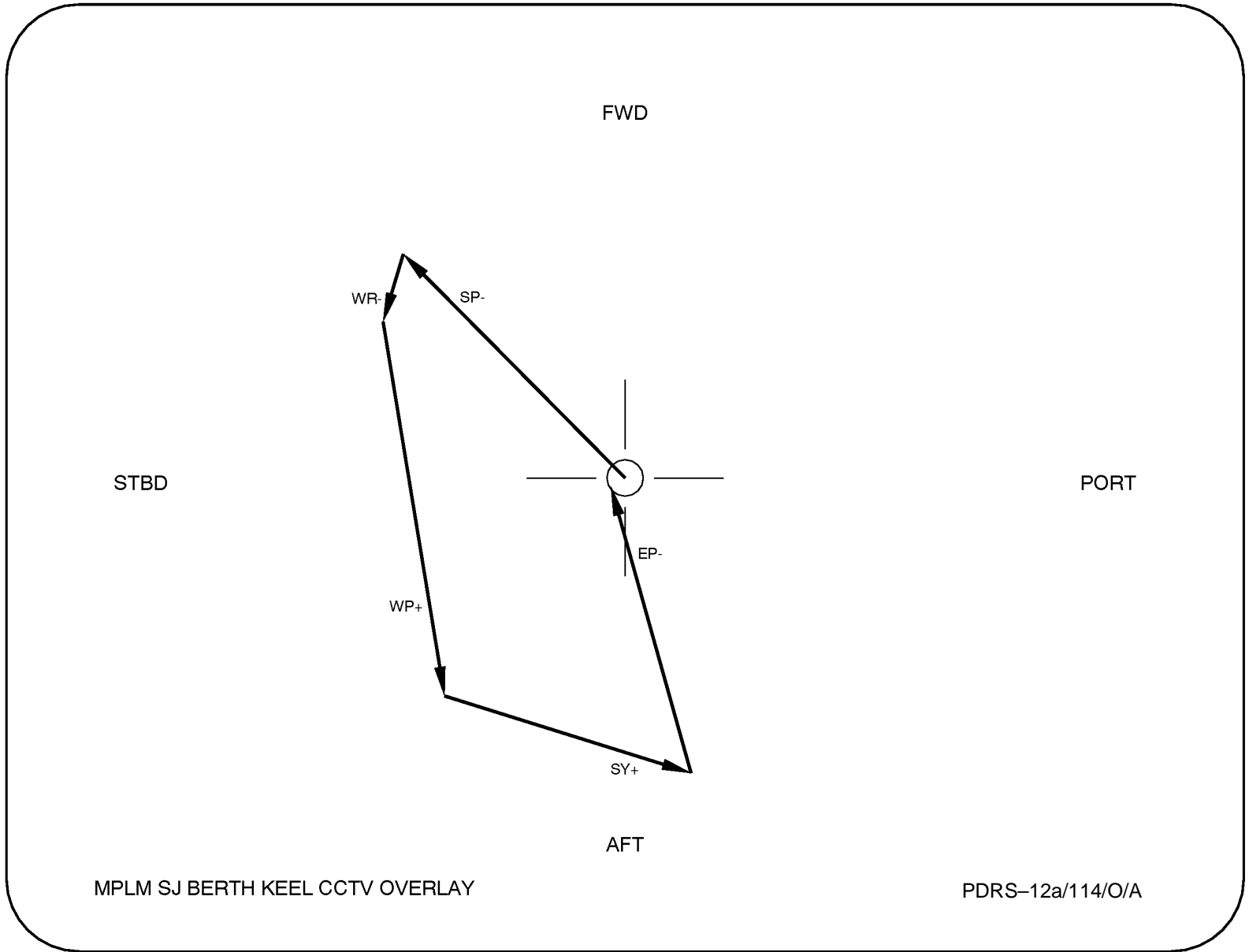

MPLM SJ BERTH KEEL CCTV OVERLAY

PDRS-12a/114/O/A

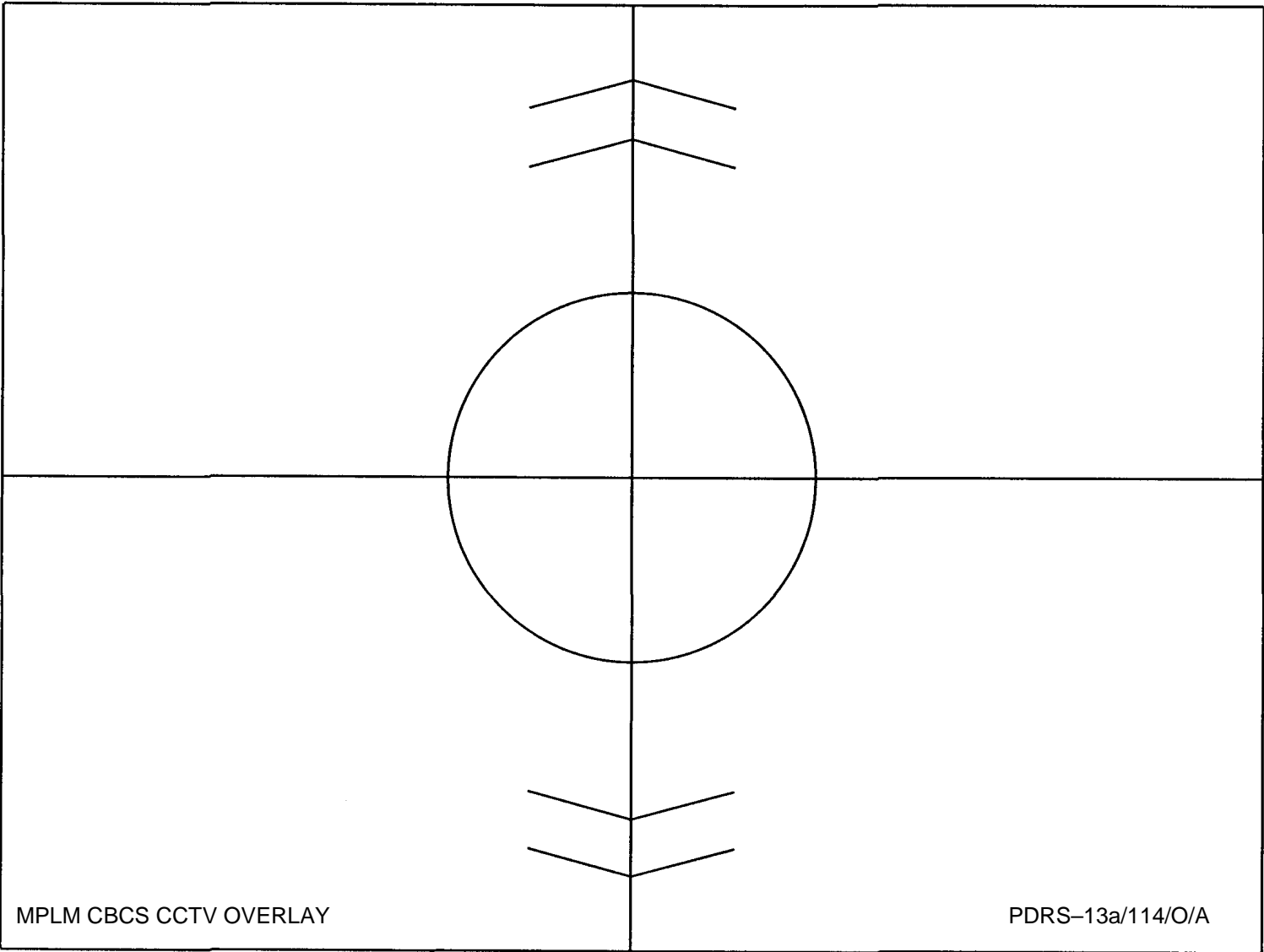

FAB USE ONLY

FS CC 11-8

PDRS/114/BAS A

MPLM CBCS CCTV OVERLAY

PDRS-13a/114/O/A

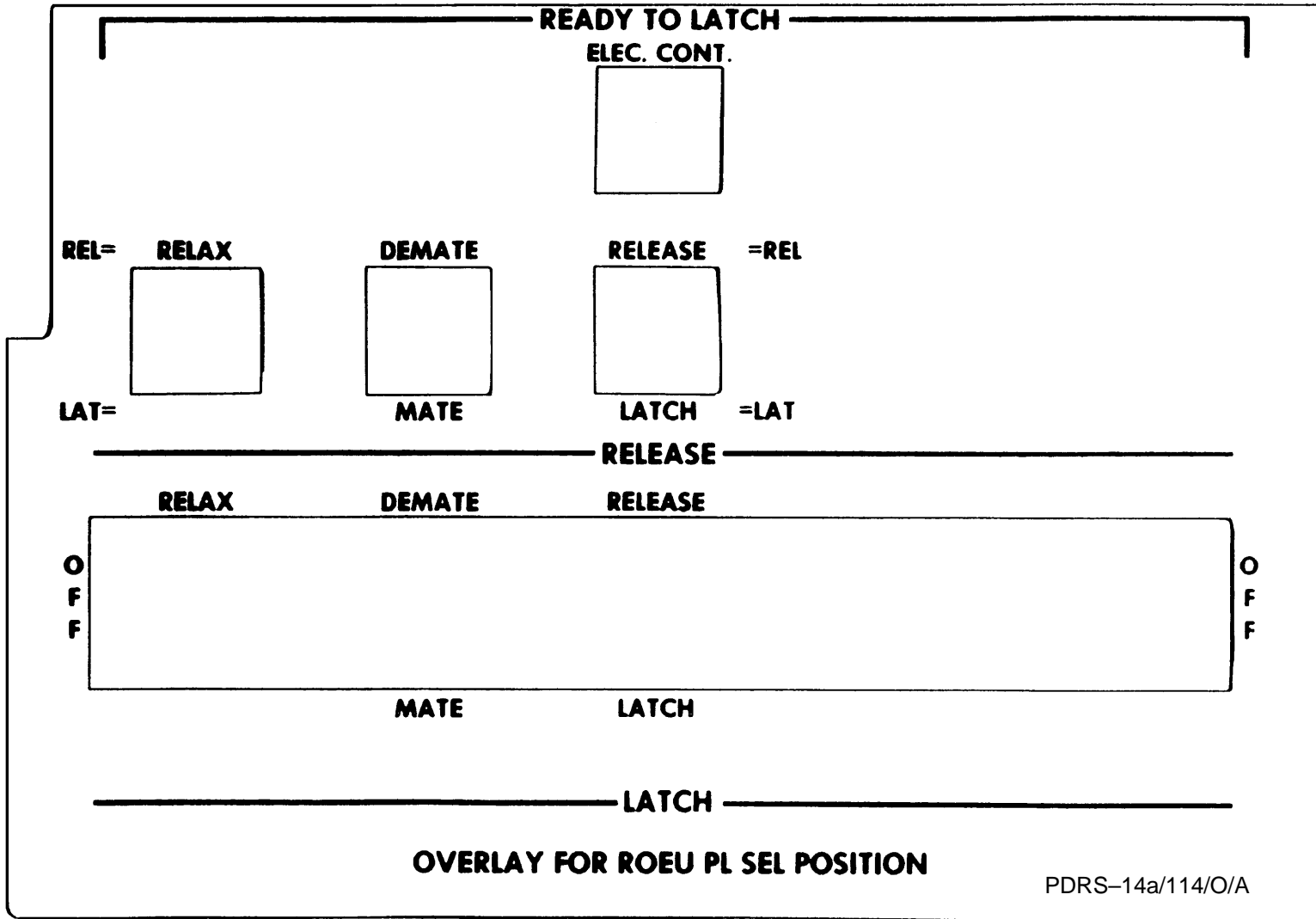

OVERLAY FOR ROEU PL SEL POSITION

PDRS-14a/114/O/A

This Page Intentionally Blank



PDRS OPS C/L

**STS
114**