

PDRS Operations Checklist

STS-130 Flight Supplement

**Mission Operations Directorate
EVA, Robotics, & Crew Systems
Operations Division**

**Final
October 30, 2009**

National Aeronautics and
Space Administration

Lyndon B. Johnson Space Center
Houston, Texas

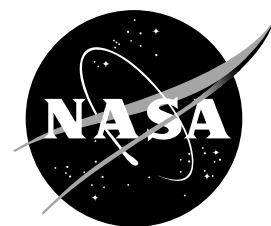

PDRS OPS CHECKLIST 130 FLT SUPPL

FINAL (Oct 30, 2009)

PCN-1 (Jan 8, 2010) Sheet 1 of 1

List of Implemented Change Requests (482s):

PDRS FS-00161

Incorporate the following:

1. Replace FS iii and FS iv
2. Replace FS 2-5 and FS 2-6, FS 2-13 and FS 2-14

Prepared by:

Book Manager

Approved by:

Lead, Shuttle and Exploration Robotics
Operations Group

Accepted by:

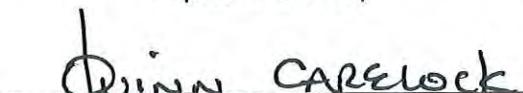
Chief, Robotics Operations Branch

Encl: 6 pages

File this PCN immediately behind the front cover as a permanent record

MISSION OPERATIONS DIRECTORATE

**PDRS OPERATIONS CHECKLIST
STS-130 FLIGHT SUPPLEMENT**

FINAL
October 30, 2009

PREPARED BY:

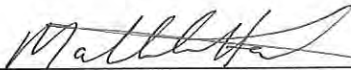

Mathew G. Hart
Book Manager

APPROVED BY:



Aaron D. Goldenthal
Lead, Shuttle and Exploration Robotics
Operations Group



Quinn L. Carelock
Chief, Robotics Operations Branch

This document is under the configuration control of the Crew Procedures Control Board (CPCB). All proposed changes must be submitted via Change Request Workflow (CRW) to DO3/FDF Manager.

Additional distribution of this book, for official use only, may be requested in writing to DO3/PMO Administrator. The request must include justification and requester's name, organization, position, and phone number. Contractor requests are made through the NASA or DOD organization supported. Deletions, reduction in quantity, or change of address may be submitted to DO3/FDF Management Office, 281-244-1184.

Incorporates the following:
482#: PDRS FS-00149

AREAS OF TECHNICAL RESPONSIBILITY

Book Manager

DX2/M. Hart

281-483-2584

PDRS OPERATIONS CHECKLIST
 STS-130 FLIGHT SUPPLEMENT

LIST OF EFFECTIVE PAGES

FINAL 10/30/09
 PCN-1 01/08/10

Sign Off	*	130/FIN	FS 2-26	⊗	130/FIN
FS ii	*	130/FIN	FS 2-27	⊗	130/FIN
FS iii	*	130/FIN 1	FS 2-28		130/FIN
FS iv	*	130/FIN	FS 2-29	⊗	130/FIN
FS v		130/FIN	FS 2-30	⊗	130/FIN
FS vi		130/FIN	FS 2-31	⊗	130/FIN
FS 1-1		130/FIN	FS 2-32	⊗	130/FIN
FS 1-2		130/FIN	FS 3-1		130/FIN
FS 1-3	⊗	130/FIN	FS 3-2		130/FIN
FS 1-4		130/FIN	FS 4-1	*	130/FIN
FS 1-5	⊗	130/FIN	FS CC 4-2	*	130/FIN
FS 1-6	⊗	130/FIN			
FS 1-7	⊗	130/FIN			
FS 1-8	⊗	130/FIN			
FS 1-9	⊗	130/FIN			
FS 1-10	⊗	130/FIN			
FS 1-11	⊗	130/FIN			
FS 1-12	⊗	130/FIN			
FS 1-13	⊗	130/FIN			
FS 1-14		130/FIN			
FS 2-1		130/FIN			
FS 2-2		130/FIN			
FS 2-3	⊗	130/FIN			
FS 2-4		130/FIN			
FS 2-5		130/FIN 1			
FS 2-6	⊗	130/FIN			
FS 2-7		130/FIN			
FS 2-8		130/FIN			
FS 2-9	⊗	130/FIN			
FS 2-10	⊗	130/FIN			
FS 2-11	⊗	130/FIN			
FS 2-12	⊗	130/FIN			
FS 2-13		130/FIN			
FS 2-14		130/FIN 1			
FS 2-15		130/FIN			
FS 2-16	⊗	130/FIN			
FS 2-17		130/FIN			
FS 2-18	⊗	130/FIN			
FS 2-19	⊗	130/FIN			
FS 2-20	⊗	130/FIN			
FS 2-21	⊗	130/FIN			
FS 2-22		130/FIN			
FS 2-23		130/FIN			
FS 2-24	⊗	130/FIN			
FS 2-25	⊗	130/FIN			

* – Omit from flight book
 ⊗ – Flight copies of this page contain color

PDRS CUE CARDS

<u>Title</u>	<u>Ref. Page</u>	<u>Card No.</u>
OBSS SJ GRAPPLE AT HANDOFF	FS CC 4-2	PDRS-9a/130/O/B

CONTENTS

PAGE

<u>OBSS NOMINAL</u>	FS 1-1
OBSS GRAPPLE FROM SSRMS.....	FS 1-2
MNVR TO UNDOCK.....	FS 1-9
FLAT FIELD.....	FS 1-11
<u>OBSS CONTINGENCY</u>	FS 2-1
OBSS HANDOFF TO SSRMS	FS 2-3
SJ GRAPPLE FROM SSRMS.....	FS 2-8
SJ MNVR TO UNDOCK.....	FS 2-22
OBSS HOVER.....	FS 2-28
<u>REFERENCE DATA</u>	FS 3-1
JOINT ANGLES VS POR COORDINATES	FS 3-2
<u>CUE CARD CONFIGURATION</u>	FS 4-1

This Page Intentionally Blank

OBSS NOMINAL

OBSS GRAPPLE FROM SSRMS.....	FS 1-2
MNVR TO UNDOCK.....	FS 1-9
FLAT FIELD	FS 1-11

**OBSS
NOMINAL**

OBSS GRAPPLE FROM SSRMS

OBSS
NOMINAL

1. SETUP

SM 94 PDRS CONTROL

√ PL ID, ITEM 3: 0

√ INIT ID, ITEM 24: 0

Verify SRMS at PRE-CRADLE posn:

X	Y	Z	PITCH	YAW	ROLL	PL ID
-1261	-146	-551	5	2	0	0
SY	SP	EP	WP	WY	WR	
0.0	+25.0	-25.0	+5.0	0.0	0.0	

R12

√ Green Jumper – ISS

MON 1 (SSC 1)	B
MON 2 (71)	P1 LOOB
DNLK (72)	A
DTV (SSC2)	Elbow (EE)

2. MNVR TO OBSS HANDOFF PRE-GRAPPLE

Verify SSRMS at DOCKING posn:

SR	SY	SP	EP	WP	WY	WR
+90.1	+210.1	-139.5	-111.5	-109.3	-110.8	+210.6

SM 94 PDRS CONTROL

END POS – ITEM 18 -1 0 4 7 -3 6 0 -6 5 8 EXEC

ATT – ITEM 21 +2 8 4 +0 +2 7 0 EXEC

CMD CK – ITEM 25 EXEC (GOOD)

RHC

RATE – VERN (RATE MIN tb-ON)

BRAKES – OFF (tb-OFF)

MODE – OPR CMD, ENTER (READY lt on)

AUTO SEQ – PROCEED (IN PROG lt on)

When AUTO SEQ IN PROG lt – off:

BRAKES – ON (tb-ON)

OBSS HANDOFF PRE-GRAPPLE posn:

X	Y	Z	PITCH	YAW	ROLL	PL ID
√ -1047	-360	-658	284	0	270	0
SY	SP	EP	WP	WY	WR	
√ +22.7	+57.5	-27.5	-99.2	+11.7	-97.7	

**Notify SSRMS Operator that SRMS at OBSS HANDOFF PRE-GRAPPLE posn;
SSRMS GO for OBSS Grapple**

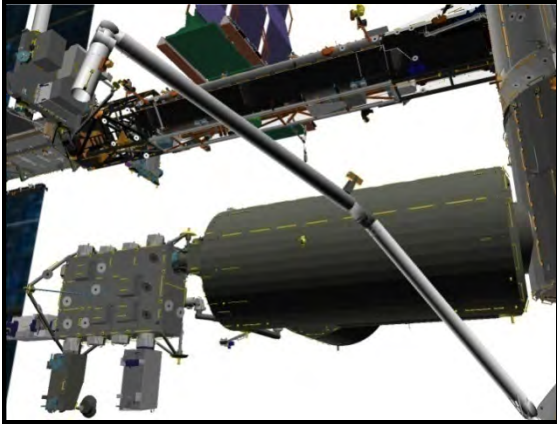

CCTV B (-25,20)

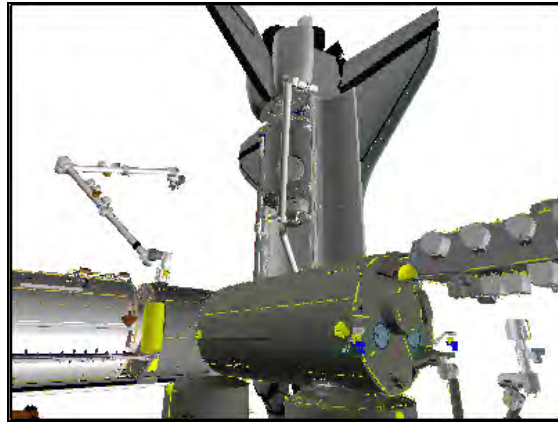

P1 LOOB (130,20)



CCTV A (20,25)

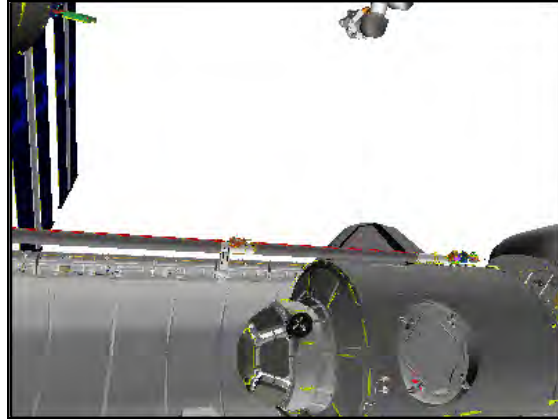

ELBOW (-105,5)

3. CONFIGURE POWER

CAUTION
 SPEE power must be applied within 90 min
 to prevent sensor package damage

**On SSRMS Operator GO to release stbd MRLs,
 STBD RMS HTR A,B (two) – OFF**

- A6U EVENT TIMER MODE – UP
 CNTL – START

- MA73C:C cb MCA PWR AC3 3Φ MID 2 – op
 √AC2 3Φ MID 2 – op
- MA73C:D √AC3 3Φ MID 4 – op

- R13L PL BAY MECH PWR SYS (two) – ON

4. STBD MRL RELEASE

SM 94 PDRS CONTROL
 RMS STBD – ITEM 2 EXEC (*)
 √STBD AFT, MID, FWD REL (six) = 0

NOTE
 Expect single motor drive time for MRL release

STBD RMS RETEN LAT – REL (tb-REL) (18 sec max)
– OFF

If motor drive time > 18 sec, √MCC

SM 94 PDRS CONTROL
√STBD AFT, MID, FWD REL (six) = 1

5. RECONFIGURE POWER
R13L PL BAY MECH PWR SYS (two) – OFF
MA73C:C cb MCA PWR AC3 3Φ MID 2 – cl
√AC2 3Φ MID 2 – op
MA73C:D √AC3 3Φ MID 4 – op

Give SSRMS Operator GO for OBSS Unberth and Mnvr to Handoff
Monitor RFL Status

After OBSS Unberth,
SM 94 PDRS CONTROL
RMS PORT – ITEM 1 EXEC (*)

6. SETUP FOR GRAPPLE
A7U CCTV – configure for grapple
– install PDRS TARGET OVERLAY FOR CTVM
– RMS WRIST, ZOOM: 34.0 HFOV
– RMS WRIST, FOCUS: 5 ft

Maintain eyepoint approx 18 in when using grapple overlay

- R12 (OBSS) √SPEE PWR – OFF
A15 APCU 2 CONV – OFF

SM 179 POWER TRANSFER
√PTU 2 APCU OUT VOLTS: <10V

7. OBSS GRAPPLE AT HANDOFF POSN
On SSRMS Operator GO for SRMS OBSS Grapple

- RHC RATE – VERN (RATE MIN tb-ON)
BRAKES – OFF (tb-OFF)
MODE – END EFF, ENTER

Mnvr to grapple envelope

CAUTION
Monitor EE tb timing to prevent EE motor burnout

EE MODE – AUTO
CAPTURE sw – depress (mom)

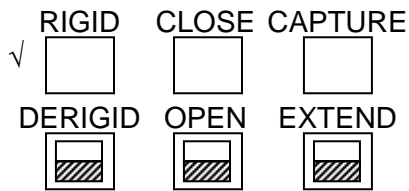

CRITICAL TIMES (28 sec total):
 CAPTURE tb – gray, then
 CLOSE tb – gray, 3 sec max, then
 RIGID tb – gray, 25 sec max

EE MODE – OFF

- * If manual capture required: *
- * EE MODE – MAN *
- * CAPTURE sw – depress (hold until CLOSE tb-gray, 3 sec max) *
- * MAN CONTR – RIGID (hold until RIGID tb-gray, 25 sec max) *
- * MODE – OFF *

MODE – TEST, ENTER
 Wait 5 sec

BRAKES – ON (tb-ON)

SM 94 PDRS CONTROL
 PL ID – ITEM 3 +2 EXEC
 INIT ID – ITEM 24 +2 EXEC

Expected OBSS HANDOFF posn:

X	Y	Z	PITCH	YAW	ROLL	PL ID
-1059	+231	-597	284	270	270	2
SY	SP	EP	WP	WY	WR	
+24.5	+59.0	-42.1	-85.9	+11.2	-99.4	

*Display singularity

Give SSRMS Operator GO for OBSS Ungrapple

Review GENERIC END EFFECTOR CUE CARD – ISS/SHUTTLE DOCKED OPS

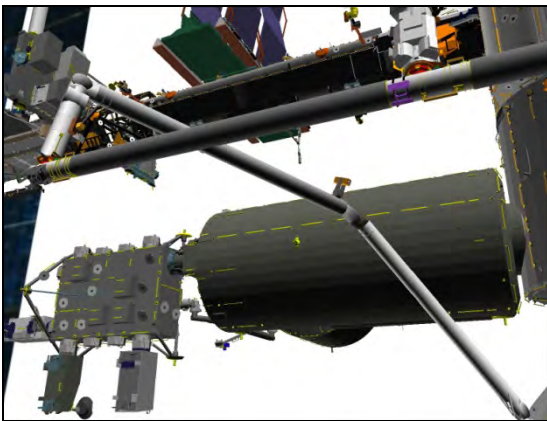

CCTV B (-25,20)

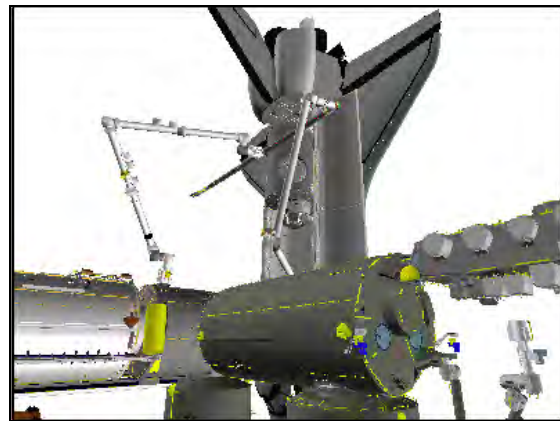

P1 LOOB (130,20)



CCTV A (20,25)

8. OBSS SENSOR PACKAGE ACTIVATION
 Perform ACTIVATION (LDRI/ITVC Cue Card, PHOTO/TV)
 LCH ACTIVATION (LCS Cue Card, PHOTO/TV)
 LCC ACTIVATION (LCS Cue Card, PHOTO/TV), steps 1 and 2
 LCC DEACTIVATION (LCS Cue Card, PHOTO/TV)
9. SINGLE JOINT MNVR TO NODE 3 INSTALL VIEWING
On SSRMS Operator GO for OBSS Mnvr to NODE 3 INSTALL VIEWING

R12 Green Jumper – ISS

MON 1 (SSC 1)	A (Elbow)
MON 2 (71)	P1 LOIB (P1 LOOB)
DNLK (72)	B
DTV (SSC2)	RSC

RHC RATE – as reqd (VERN within 10 ft)
 BRAKES – OFF (tb-OFF)
 MODE – SINGLE, ENTER

Mnvr to NODE 3 INSTALL VIEWING posn:

	SY	SP	EP	WP	WY	WR	
OBSS	+24.5	+59.0	-42.1	-85.9	+11.2	-99.4	
HANDOFF						-75.0	
1: WR +							
2: EP +			-20.0				
3: WP +				-10.0			
4: WR +						-45.0	
5: SP –		+44.7					
6: SY +	+64.0						
7: WR +						+30.0	
NODE 3	+64.0	+44.7	-20.0	-10.0	+11.2	+30.0	
VIEWING	X	Y	Z	PITCH	YAW	ROLL	PL ID
	-726	-732	-1148	106	9	282	2

BRAKES – ON (tb-ON)
 MODE – not DIRECT (lt off)
 PARAM – PORT TEMP
 JOINT – CRIT TEMP

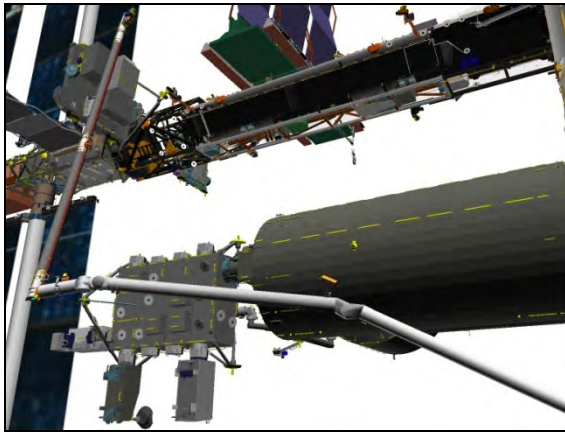

CCTV B (-30,20)



ELBOW (25,5)

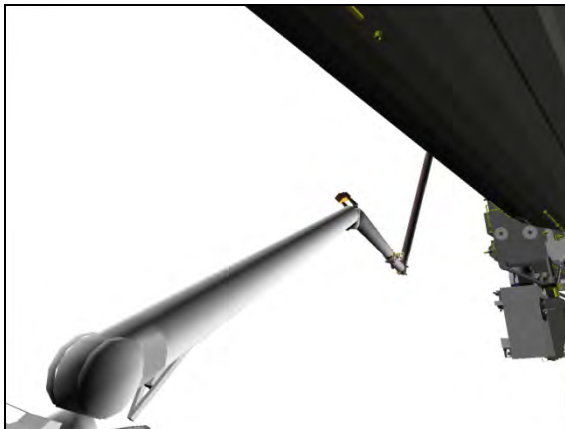

CCTV A (45,20)

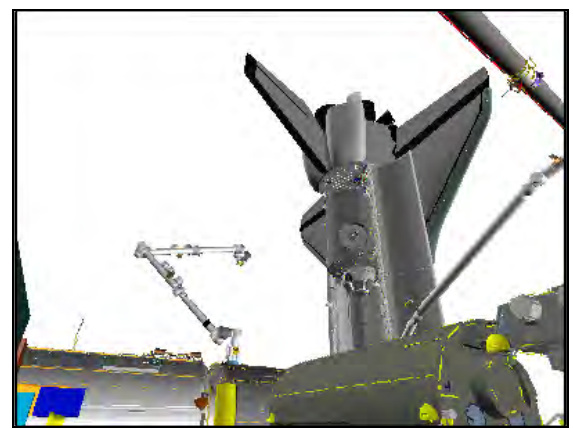

P1 LOOB (120,30)

R12
A7U

10. RECONFIGURE PTU
Green Jumper – LDRI/ITVC
DTV ← PL2

CAMR CMD PAN/TILT – HI RATE
 PAN – L (to hard stop)
 TILT – UP (to hard stop)
 PAN/TILT – RESET, HI RATE (LO within 10°)
 PAN: +100 (right)
 TILT: -35 (down)

MUX 1 L ← MIDDECK
 LDRI MODE 2 pb – push (ITVC video)
 VIDEO OUT – as desired (not DTV)
 √VIDEO IN – not PL2

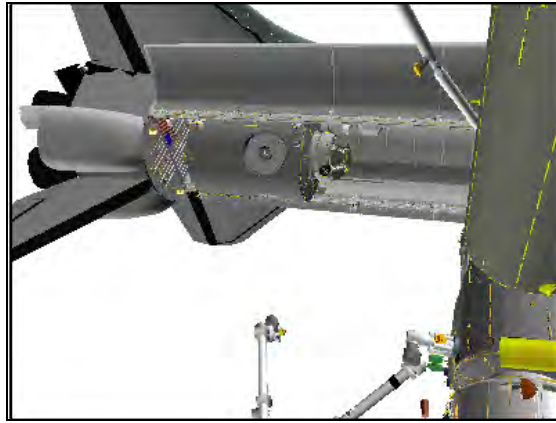

OBSS ITVC (100,-35)

OBSS MNVR TO UNDOCK

1. SETUP

Verify SSRMS at UNDOCK posn:

SR	SY	SP	EP	WP	WY	WR
+71.0	+170.0	+177.2	+94.0	-41.0	+10.0	+110.8

SM 94 PDRS CONTROL

√ PL ID, ITEM 3: 2

√ INIT ID, ITEM 24: 2

Verify at NODE 3 INSTALL VIEWING posn:

X	Y	Z	PITCH	YAW	ROLL	PL ID
√ -726	√ -732	√ -1148	√ 106	√ 9	√ 282	√ 2
SY	SP	EP	WP	WY	WR	
√ +64.0	√ +44.7	√ -20.0	√ -10.0	√ +11.2	√ +30.0	

R12

Green Jumper – ISS

MON 1 (SSC 1)	B (D)
MON 2 (71)	P1 LOOB (ELBOW)
DNLK (72)	A
DTV (SSC2)	RSC

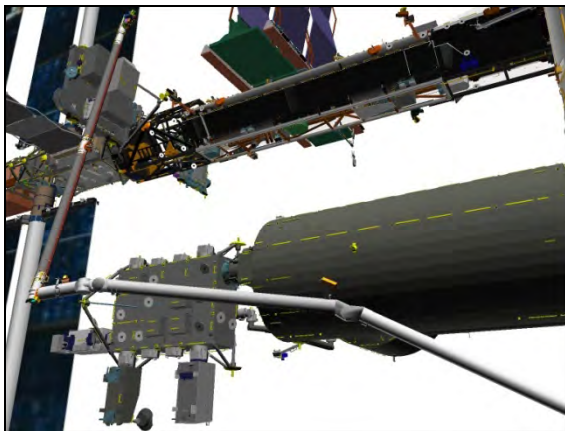

CCTV B (-30,20)



ELBOW (25,5)

2. OBSS MNVR TO UNDOCK

NOTE

When SY is driving, use CCTV D to monitor clearance between OBSS and Orbiter Tail.

When SP is driving, minimum clearance between Upper Boom and JEM is 40 inches; use CCTV A to monitor. Minimum clearance between OBSS and SSRMS is 116 inches; use P1 LOOB to monitor

RHC RATE – as reqd (VERN within 10 ft)
 BRAKES – OFF (tb-OFF)
 MODE – SINGLE, ENTER

Mnvr to UNDOCK posn:

NODE 3
 VIEWING
 1: WR –
 2: SY –
 3: SP +
 4: WP –
 5: WR –
 6: EP –
 UNDOCK

SY	SP	EP	WP	WY	WR	
+64.0	+44.7	-20.0	-10.0	+11.2	+30.0	
					-60.0	
+25.8						
	+66.3					
			-85.9			
					-100.7	
		-49.0				
+25.8	+66.3	-49.0	-85.9	+11.2	-100.7	
X	Y	Z	PITCH	YAW	ROLL	PL ID
-1030	+228	-610	284	270	270	2

*Display singularity

BRAKES – ON (tb-ON)
 MODE – not DIRECT (lt off)
 PARAM – PORT TEMP
 JOINT – CRIT TEMP



CCTV B (-30,20)

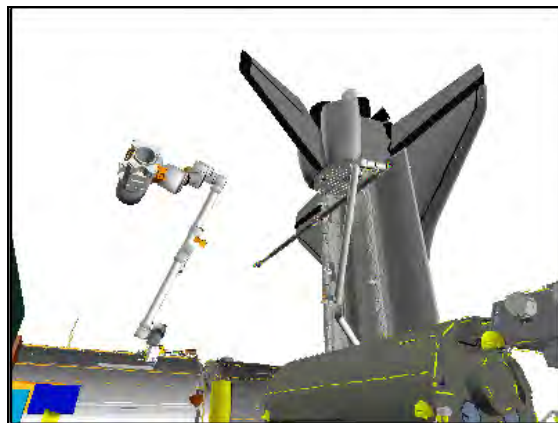

P1 LOOB (130,20)

OBSS MNVR TO FLAT FIELD

WARNING
For UNDOCKED ops only

1. SETUP

SM 94 PDRS CONTROL

- √ PL ID, ITEM 3: 2
- √ INIT ID, ITEM 24: 2

Verify at UNDOCK posn:

	X	Y	Z	PITCH	YAW	ROLL	PL ID	
√	-1030	+228	-610	284	270	270	2	*
	SY	SP	EP	WP	WY	WR		
√	+25.8	+66.3	-49.0	-85.9	+11.2	-100.7		

*Display singularity

MON 1 (SSC 1)	D
MON 2 (71)	B (A)
DNLK (72)	C
DTV (SSC2)	ELBOW



CCTV A (0,25)

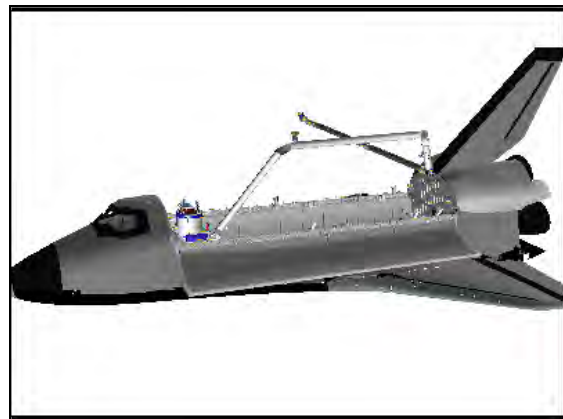

BIRD'S EYE

2. MNVR TO INTERMEDIATE

SM 94 PDRS CONTROL

- END POS – ITEM 18 -8 0 0 +5 0 0 -2 5 0 EXEC
- ATT – ITEM 21 +2 8 1 +3 3 3 +9 5 EXEC
- CMD CK – ITEM 25 EXEC (GOOD)

RHC

- RATE – as reqd (VERN within 10 ft)
- BRAKES – OFF (tb-OFF)
- MODE – OPR CMD, ENTER (READY lt on)

AUTO SEQ – PROCEED (IN PROG lt on)

- When AUTO SEQ IN PROG lt – off:
- BRAKES – ON (tb-ON)

Verify at INTERMEDIATE posn:

X	Y	Z	PITCH	YAW	ROLL	PL ID
-800	+500	-250	281	333	95	2
SY	SP	EP	WP	WY	WR	
-86.6	+72.8	-85.9	+21.1	-3.3	-169.2	



ELBOW (-20,-20)

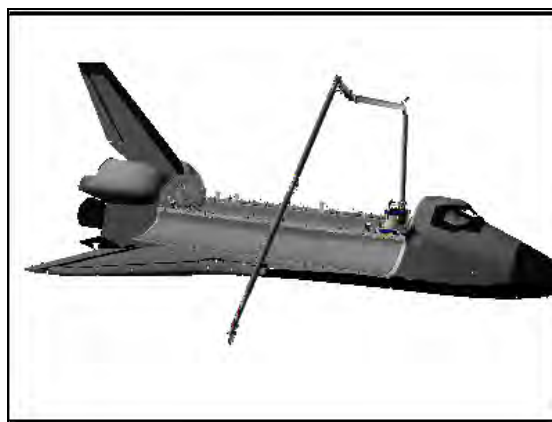

BIRD'S EYE

3. MNVR TO FLAT FIELD

RHC
 RATE – as reqd (VERN within 10 ft)
 BRAKES – OFF (tb-OFF)
 MODE – SINGLE, ENTER

Mnvr to FLAT FIELD posn:

	SY	SP	EP	WP	WY	WR	
	-86.6	+72.8	-85.9	+21.1	-3.3	-169.2	
INTERM							
1: WR –						-249.9	
2: SY –	-90.1						
3: WY +					0.0		
4: WP –				-57.6			
5: EP +			-65.8				
6: SP –		+25.0					
FLAT FIELD	-90.1	+25.0	-65.8	-57.6	0.0	-249.9	
	X	Y	Z	PITCH	YAW	ROLL	PL ID
	-1270	+350	-445	0	0	11	2

BRAKES – ON (tb-ON)
 MODE – not DIRECT (lt off)

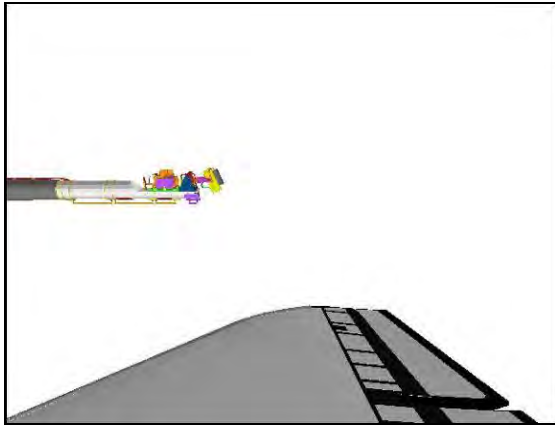

CCTV C (95,-5)

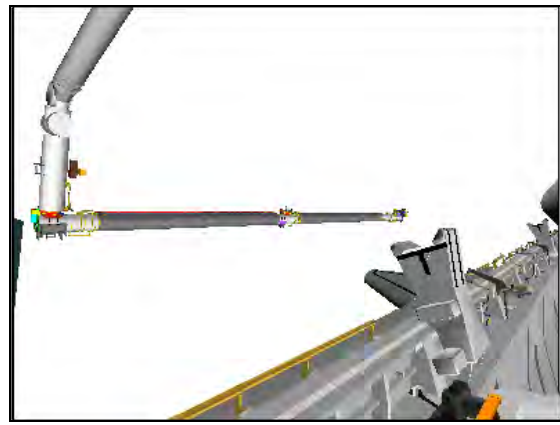

CCTV D (-40,0)

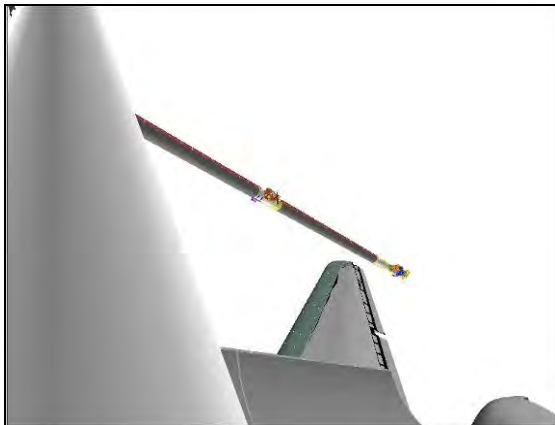

ELBOW (25,-40)

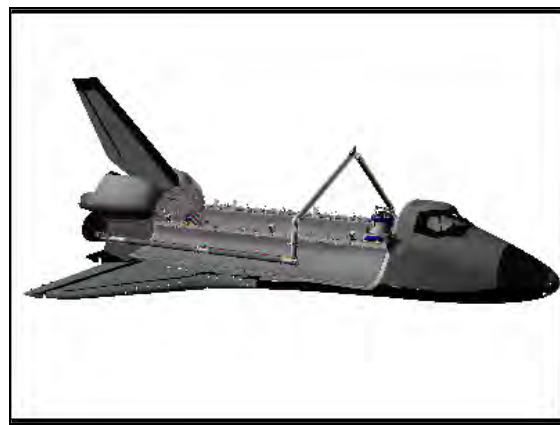

BIRD'S EYE

4. SETUP FOR STBD SURVEY

SM 94 PDRS CONTROL

AUTO MODES – ITEM 13 +1 +2 +3 +4 EXEC

For survey scan pattern, refer to OBSS SCAN PATTERN CUE CARDS – STBD & PORT, AND WING GLOVE AND CREW CABIN

Perform ACTIVATION (LDRI/ITVC Cue Card, PHOTO/TV) steps 1, 3, 4, and 5

A15 APCU 2 CONV – OFF
Wait 10 sec
APCU 2 CONV – ON

Perform LCC ACTIVATION (LCS Cue Card, PHOTO/TV)
Perform IDC SOFTWARE ACTIVATION (IDC Cue Card, PHOTO/TV) steps 1 and 2

A7U MUX 1 L ← MIDDECK
LDRI MODE 6 pb – lit (flickering LDRI video)
√DTV ← PL2

CAMR CMD PAN/TILT – HI RATE
PAN – L (to hard stop)
TILT – UP (to hard stop)
PAN/TILT – RESET, HI RATE (LO within 10°)
PAN: +103 (right)
TILT: -260 (dn)

VIDEO OUT – as desired (not DTV)
√VIDEO IN – not PL2

L10 (VTR) REC pb – push, hold
PLAY pb – push, simo (red ●)

BRAKES – OFF (tb-OFF)

Go to OBSS LDRI/IDC RCC SURVEY – STBD (OBSS OPERATIONS), step 5.
Reference page 7-9 for procedure Notes

OBSS CONTINGENCY

OBSS HANDOFF TO SSRMS.....	FS 2-3
SJ GRAPPLE FROM SSRMS	FS 2-8
SJ MNVR TO UNDOCK.....	FS 2-22
OBSS HOVER	FS 2-28

**OBSS
CONTINGENCY**

This Page Intentionally Blank

OBSS HANDOFF TO SSRMS

1. SETUP

MON 1 (SSC 1)	B
MON 2 (71)	P1 LOOB
DNLK (72)	A
DTV (SSC 2)	Elbow (EE)

SM 94 PDRS CONTROL

√ PL ID, ITEM 3: 2

√ INIT ID, ITEM 24: 2

Verify SRMS at OBSS HANDOFF posn:

X	Y	Z	PITCH	YAW	ROLL	PL ID
√ -1059	+231	-597	284	270	270	2
	SY	SP	EP	WP	WY	WR
√ +24.5	+59.0	-42.1	-85.9	+11.2	-99.4	

*Display singularity

**Notify SSRMS Operator that SRMS at OBSS HANDOFF with Brakes ON;
GO for SSRMS OBSS Grapple**

Review GENERIC END EFFECTOR CUE CARD – ISS/SHUTTLE DOCKED OPS

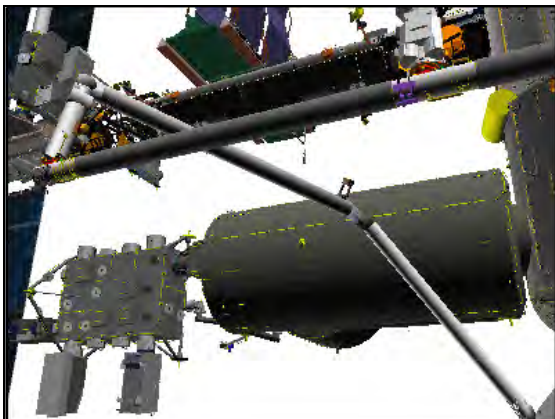

CCTV B (-25,20)

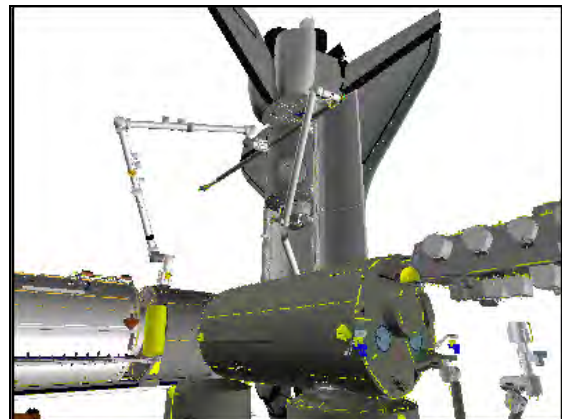

P1 LOOB (130,20)



CCTV A (20,25)

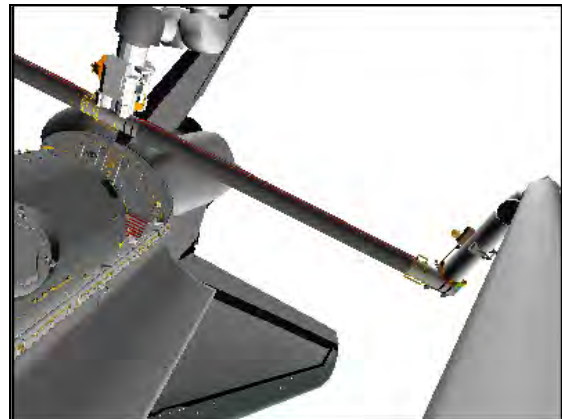

ELBOW (-35,-10)

2. STOW PTU
R12 (VPU) Green Jumper – LDRI/ITVC

A7U DTV ← PL2

CAMR CMD PAN/TILT – HI RATE
PAN – L (to hard stop)
TILT – UP (to hard stop)
PAN/TILT – RESET
PAN: +108 (right)
TILT: -175 (down)

R12 (VPU) Green Jumper – ISS

On SSRMS Operator GO for SRMS OBSS Ungrapple,

<p><u>CAUTION</u> STBD RMS HTR power must be applied within 90 min to prevent sensor package damage</p>

Perform LCC DEACTIVATION (LCS Cue Card, PHOTO/TV)
Perform LCH DEACTIVATION (LCS Cue Card, PHOTO/TV)
Perform DEACTIVATION (LDRI/ITVC Cue Card, PHOTO/TV)

3. OBSS UNGRAPPLE
A7U CCTV – configure for ungrapple
– RMS WRIST, ZOOM: 34.0 HFOV
FOCUS: 5 ft

R12 (OBSS) √SPEE PWR – OFF

NOTE
CONTR ERR It and 'S96 PDRS CNTL' msg may
occur due to Consistency/Envelope Check error

RHC RATE – COARSE (RATE MIN tb-OFF)

<p><u>SM 94 PDRS CONTROL</u></p>

AUTO BRAKE INH – ITEM 10 EXEC (*)

BRAKES – OFF (tb-OFF)
MODE – TEST, ENTER
Wait 5 sec

BRAKES – ON (tb-ON)

<p><u>SM 94 PDRS CONTROL</u></p>

AUTO BRAKE ENA – ITEM 9 EXEC (*)







PL ID – ITEM 3 +0 EXEC
INIT ID – ITEM 24 +0 EXEC

RHC RATE – VERN (RATE MIN tb-ON)
BRAKES – OFF (tb-OFF)
MODE – END EFF, ENTER

CAUTION Monitor EE tb timing to prevent EE motor burnout
--

EE MODE – AUTO
 RELEASE sw – depress (mom)

When OPEN tb – gray, mnvr arm clear of grapple pin

√	RIGID  DERIGID 	CLOSE  OPEN 	CAPTURE  EXTEND 	<u>CRITICAL TIMES (28 sec total):</u> DERIGID tb – gray, 5 sec max, then OPEN tb – gray, 3 sec max, then EXTEND tb – gray, 20 sec max
---	--	---	---	--

EE MODE – OFF

- * If manual release reqd: *
- * EE MODE – MAN *
- * MAN CONTR – DERIGID (hold until DERIGID tb-gray, 5 sec max) *
- * RELEASE sw – depress (hold until OPEN tb-gray, 3 sec max) *
- * Mnvr arm clear of grapple pin, then *
- * EE MAN CONTR – DERIGID (hold until EXTEND tb-gray, 20 sec max) *
- * MODE – OFF *

Mnvr to OBSS BACKOFF posn:

X	Y	Z	PITCH	YAW	ROLL	PL ID
-1053	-360	-635	284	0	270	0
SY	SP	EP	WP	WY	WR	
+23.5	+58.7	-34.4	-93.5	+11.6	-98.4	

BRAKES – ON (tb-ON)

- * If using Shuttle attitude control and attitude maintenance reqd: *
- * DAP: LVLH *
- * When rates damped: *
- * DAP: FREE > 2 sec *
- * DAP: AUTO *

A15 If NODE 3 heater power required:
 APCU 2 CONV – ON

SM 179 POWER TRANSFER

√PTU 2 APCU OUT VOLTS: 123V TO 126V

**Notify SSRMS Operator that SRMS at OBSS BACKOFF with Brakes ON;
 GO for SSRMS OBSS Berth**

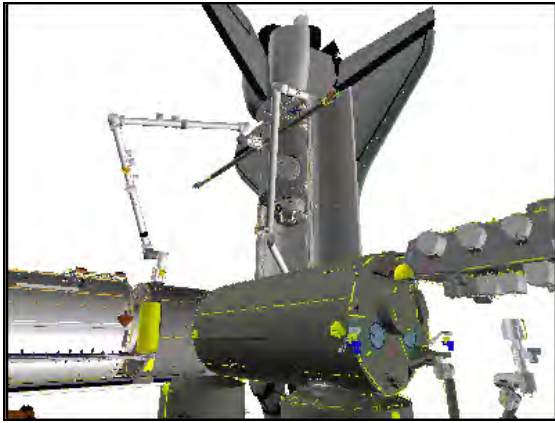

P1 LOOB (130,20)

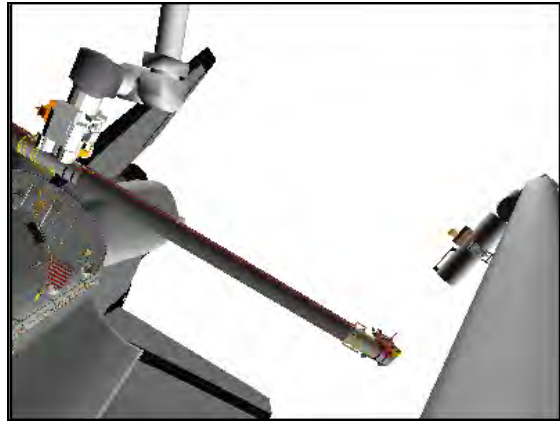

ELBOW (-35,-10)

4. CONFIGURE CIRCUIT BREAKERS
MA73C:C cb MCA PWR AC3 3Φ MID 2 – op
 √AC2 3Φ MID 2 – op
MA73C:D √AC3 3Φ MID 4 – op

5. CONFIGURE FOR MONITORING
On SSRMS Operator notification to watch for stbd RMS RFLs,

SM 94 PDRS CONTROL

RMS STBD – ITEM 2 EXEC (*)

Notify SSRMS operator when STBD RMS R-F-L tb (three) – gray

6. STBD MRL LATCH
On SSRMS Operator GO to latch stbd MRLs to Topological Capture,
√STBD RMS R-F-L tb (three) – gray

SM 94 PDRS CONTROL

√STBD AFT, MID, FWD LAT (six) = 0
Verify AOS for latching to Topological Capture
R13L PL BAY MECH PWR SYS (two) – ON

NOTE

Expect single motor drive time for MRL latching (18 sec max).
The following STBD RMS RETEN LAT – OFF and PL BAY
MECH PWR SYS (two) – OFF actions are to be performed simo

STBD RMS RETEN LAT – LAT 6 sec only (tb-bp)
– OFF

- R13L PL BAY MECH PWR SYS (two) – OFF

Give SSRMS Operator GO to Limp All SSRMS Joints and Derigidize

- R13L On SSRMS Operator GO to complete stbd MRL latching,
PL BAY MECH PWR SYS (two) – ON

STBD RMS RETEN LAT – LAT (tb-LAT) (12 sec max)
– OFF

Give SSRMS Operator GO for OBSS Release

R13L 7. RECONFIGURE POWER
PL BAY MECH PWR SYS (two) – OFF

STBD RMS HTR A,B (two) – AUTO

A6U EVENT TIMER CNTL – STOP

SM 94 PDRS CONTROL

√STBD AFT, MID, FWD LAT (six) = 1
RMS PORT – ITEM 1 EXEC (*)

MA73C:C cb MCA PWR AC3 3Φ MID 2 – cl
√AC2 3Φ MID 2 – op

MA73C:D √AC3 3Φ MID 4 – op

8. MNVR TO PRE-CRADLE
Verify SSRMS at OBSS Low Hover

MON 1 (SSC 1)	B
MON 2 (71)	P1 LOOB
DNLK (72)	A
DTV (SSC 2)	Elbow (EE)

SM 94 PDRS CONTROL

END POS – ITEM 18 -1 2 6 1 -1 4 6 -5 5 1 EXEC
ATT – ITEM 21 +5 +2 +0 EXEC
CMD CK – ITEM 25 EXEC (GOOD)

RHC RATE – as reqd (VERN within 10 ft)
BRAKES – OFF (tb-OFF)
MODE – OPR CMD, ENTER (READY lt on)

AUTO SEQ – PROCEED (IN PROG lt on)

When AUTO SEQ IN PROG lt – off:

Verify at PRE-CRADLE posn:

	X	Y	Z	PITCH	YAW	ROLL	PL ID
√	-1261	-146	-551	5	2	0	0
	SY	SP	EP	WP	WY	WR	
√	0.0	+25.0	-25.0	5.0	0.0	0.0	

BRAKES – ON (tb-ON)
MODE – not DIRECT
PARAM – PORT TEMP
JOINT – CRIT TEMP

OBSS SJ GRAPPLE FROM SSRMS

1. SETUP

Verify SSRMS at OBSS BERTHED PRE-GRAPPLE posn:

SR	SY	SP	EP	WP	WY	WR
+74.6	+217.4	-161.0	-112.7	-162.3	-158.0	+210.6

R12

√Green Jumper – ISS

MON 1 (SSC 1)	B
MON 2 (71)	P1 LOOB
DNLK (72)	A
DTV (SSC 2)	Elbow (EE)

SM 94 PDRS CONTROL

√PL ID, ITEM 3: 0

√INIT ID, ITEM 24: 0

A7U

CCTV – configure as reqd
 – perform PAN/TILT RESET for PLB cameras
 ZOOM – full OUT

2. SINGLE JOINT MANEUVER TO OBSS HANDOFF PRE-GRAPPLE

If SINGLE mode available:

RHC

RATE – as reqd (VERN within 10 ft)
 BRAKES – OFF (tb-OFF)

MODE – best available

SM 169 PDRS STATUS

Mnvr to OBSS HANDOFF PRE-GRAPPLE posn:

	SY	SP	EP	WP	WY	WR	
Pre-cradle	0.0	+25.0	-25.0	+5.0	0.0	0.0	
1: SP +		+57.4					
2: WP –				-99.2			
3: WY +					+11.7		
4: WR –						-97.7	
5: EP –			-27.5				
6: SY +	+22.7						
OBSS Handoff Pre-Grapple	+22.7	+57.5	-27.5	-99.2	+11.7	-97.7	
	X	Y	Z	PITCH	YAW	ROLL	PL ID
	-1047	-360	-658	284	0	270	0

BRAKES – ON (tb-ON)
 MODE – not DIRECT
 PARAM – PORT TEMP
 JOINT – CRIT TEMP

**Notify SSRMS Operator that SRMS at OBSS HANDOFF PRE-GRAPPLE posn;
 SSRMS GO for OBSS Grapple**

Start:
Pre-cradle

Step 1:
Drive SP+ (for 32.5°)
From +25.0 to +57.5

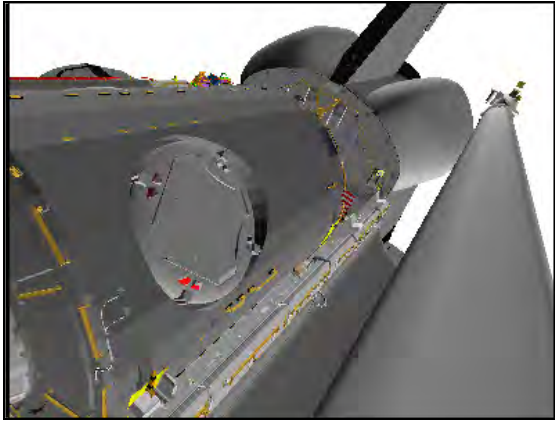

ELBOW (-30,-20)

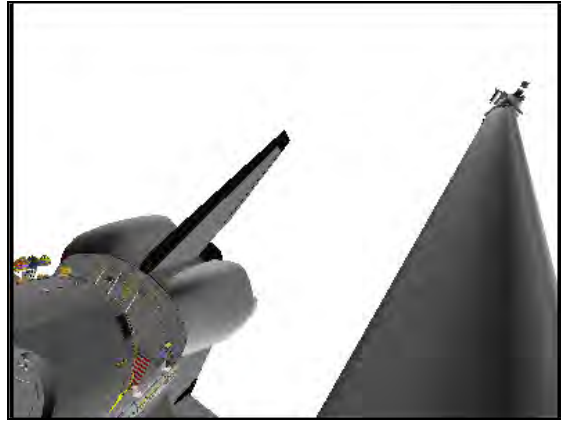

ELBOW (-30,-20)



CCTV A (-10,28)



CCTV A (-10,28)

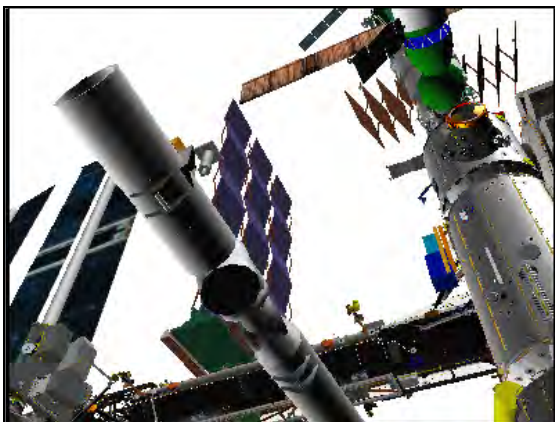

CCTV B (-25,50)

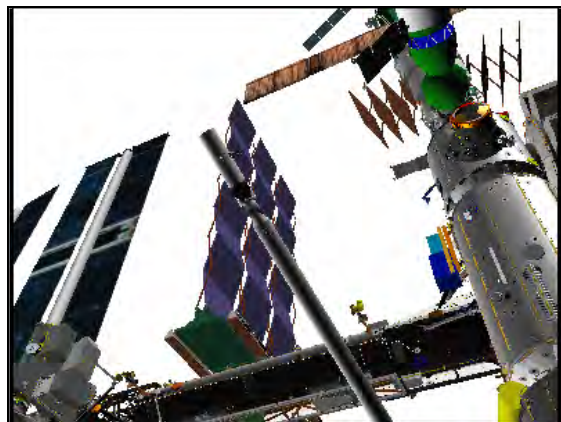

CCTV B (-25,50)

Step 2:

Drive WP- (for 104.2°)
From +5.0 to -99.2

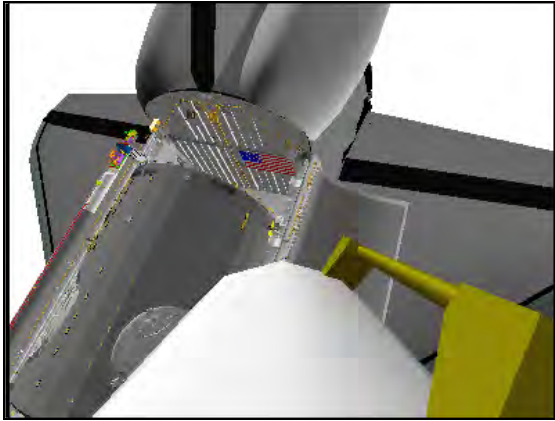

EE

Step 3:

Drive WY+ (for 11.7°)
From 0.0 to +11.7

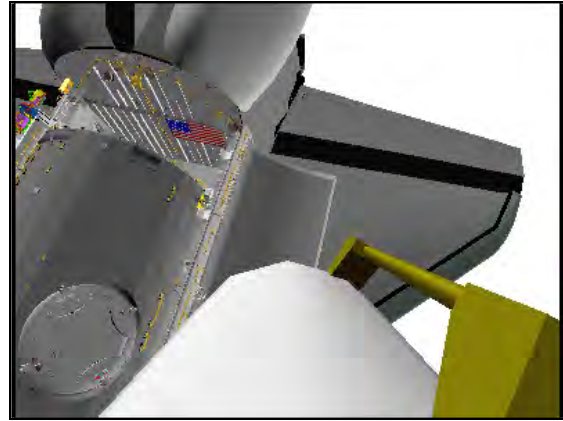

EE



CCTV A (10,28)



CCTV A (10,28)

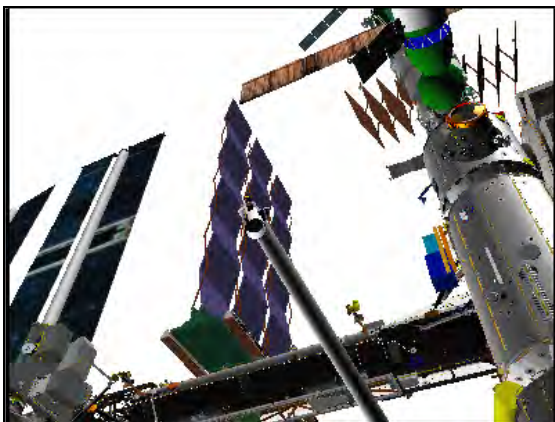

CCTV B (-25,50)

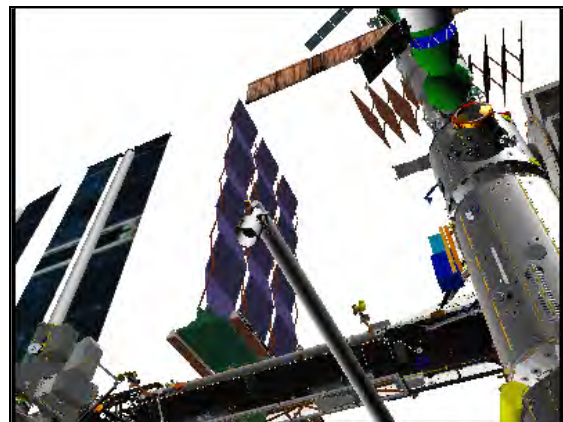

CCTV B (-25,50)

Step 4:

Drive WR- (for 97.7°)
From 0.0 to -97.7

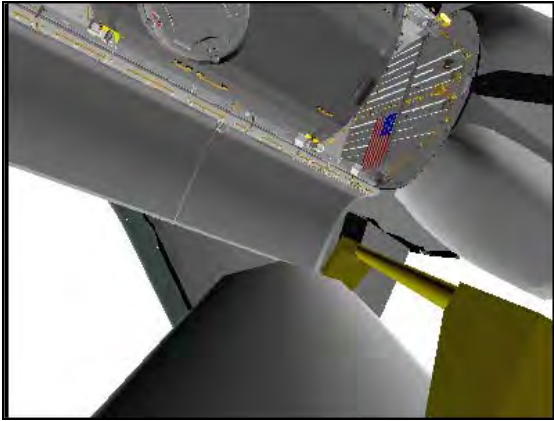

EE

Step 5:

Drive EP- (for 2.5°)
From -25.0 to -27.5

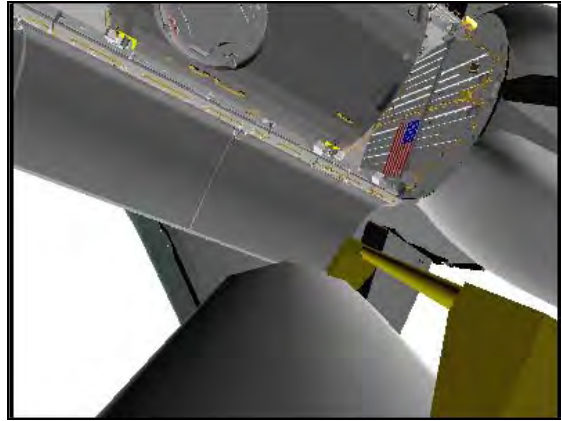

EE



CCTV A (10,28)



CCTV A (10,28)

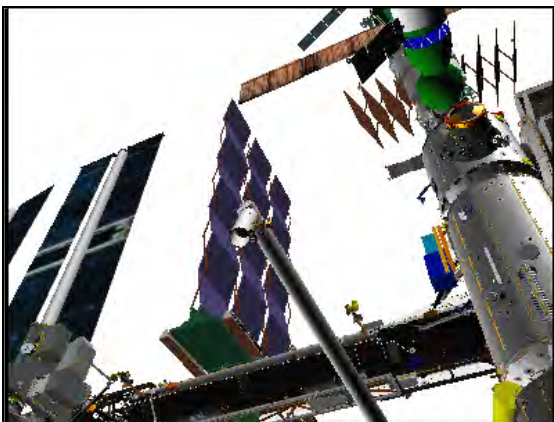

CCTV B (-25,50)

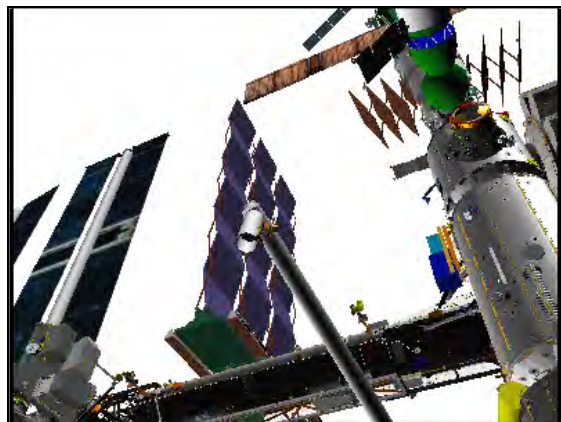

CCTV B (-25,50)

Step 6:

Drive SY+ (for 22.7°)

From 0.0 to +22.7



EE

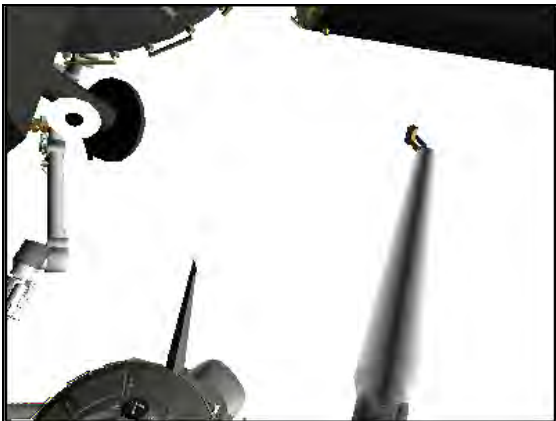

CCTV A (10,28)

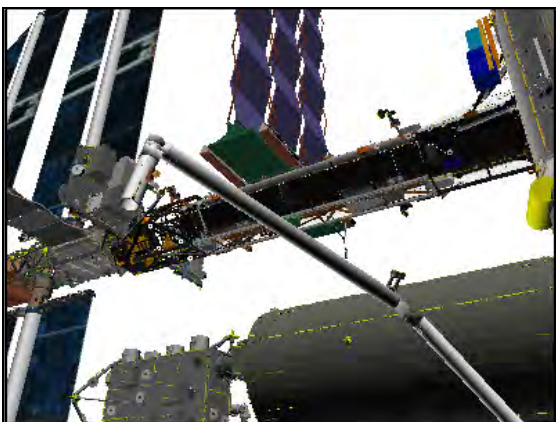

CCTV B (-30,30)

3. CONFIGURE POWER

CAUTION
SPEE power must be applied within 90 min
to prevent sensor package damage

**On SSRMS Operator GO to Release Stbd MRLs,
STBD RMS HTR A,B (two) – OFF**

A6U EVENT TIMER MODE – UP
 CNTL – START

MA73C:C cb MCA PWR AC3 3Φ MID 2 – op
 √AC2 3Φ MID 2 – op

MA73C:D √AC3 3Φ MID 4 – op

R13L PL BAY MECH PWR SYS (two) – ON

4. STBD MRL RELEASE

SM 94 PDRS CONTROL

RMS STBD – ITEM 2 EXEC (*)
√STBD AFT, MID, FWD REL (six) = 0

NOTE
Expect single motor drive time for MRL release

STBD RMS RETEN LAT – REL (tb-REL) (18 sec max)
– OFF
If motor drive time > 18 sec, √MCC

SM 94 PDRS CONTROL

√STBD AFT, MID, FWD REL (six) = 1

5. RECONFIGURE POWER

R13L PL BAY MECH PWR SYS (two) – OFF

MA73C:C cb MCA PWR AC3 3Φ MID 2 – cl
 √AC2 3Φ MID 2 – op

MA73C:D √AC3 3Φ MID 4 – op

Give SSRMS Operator GO for OBSS Unberth and SSRMS Mnvr to Handoff

Monitor RFL Status

After OBSS Unberth,
style="text-align: center;">**SM 94 PDRS CONTROL**
RMS PORT – ITEM 1 EXEC (*)

6. SETUP FOR GRAPPLE

A7U CCTV – configure for grapple
 – install OBSS SJ GRAPPLE AT HANDOFF OVERLAY
 – RMS WRIST, ZOOM: 34.0 HFOV
 FOCUS: 5 ft
Maintain eyepoint approx 18 in when using grapple overlay

R12 (OBSS) ✓SPEE PWR – OFF

A15 If NODE 3 in PLB:
APCU 2 CONV – OFF

SM 179 POWER TRANSFER

✓PTU 2 APCU OUT VOLTS: <10V

7. OBSS SJ GRAPPLE AT HANDOFF POSN

On SSRMS Operator GO for SRMS OBSS grapple:

RHC If SINGLE mode available:
RATE – VERN (RATE MIN tb-ON)
BRAKES – OFF (tb-OFF)

MODE – best available

Drive joints per OBSS SJ GRAPPLE AT HANDOFF OVERLAY and diagram until EE within grapple envelope

CAUTION
Monitor EE tb timing to prevent EE motor burnout

EE MODE – AUTO
CAPTURE sw – depress (mom)

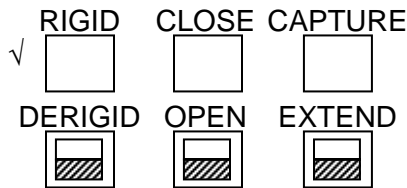

CRITICAL TIMES (28 sec total):

CAPTURE tb – gray, then
CLOSE tb – gray, 3 sec max, then
RIGID tb – gray, 25 sec max

EE MODE – OFF

- * If manual capture required: *
- * EE MODE – MAN *
- * CAPTURE sw – depress (hold until CLOSE tb-gray, 3 sec max) *
- * MAN CONTR – RIGID (hold until RIGID tb-gray, 25 sec max) *
- * MODE – OFF *

If TEST mode available,
MODE – TEST, ENTER
Wait 5 sec

BRAKES – ON (tb-ON)
MODE – not DIRECT (It off)
PARAM – PORT TEMP
JOINT – CRIT TEMP

OBSS SJ GRAPPLE AT HANDOFF

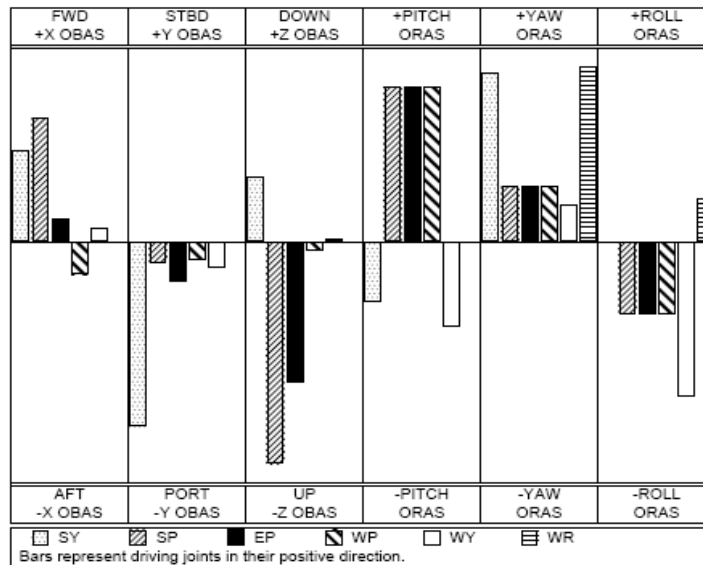

To get:	Drive:	To get:	Drive:	Driving:	Results In:	Driving:	Results In:
+X (fwd)	+SP, +SY	+PITCH	+WP, +EP	+SY	-Y (port), +YAW	+WP	-X (aft), +PITCH
+Y (stbd)	-SY	+YAW	+WR, +SY	+SP	-Z (up), +PITCH	+WY	-Y (port), -ROLL
+Z (down)	-SP, -EP	+ROLL	-WY, -WP	+EP	-Z (up), +PITCH	+WR	+YAW

ΔSY	ΔSP	ΔEP	ΔWP	ΔWY	ΔWR
+1.8	+1.9	-15.4	+13.9	-0.7	-1.7

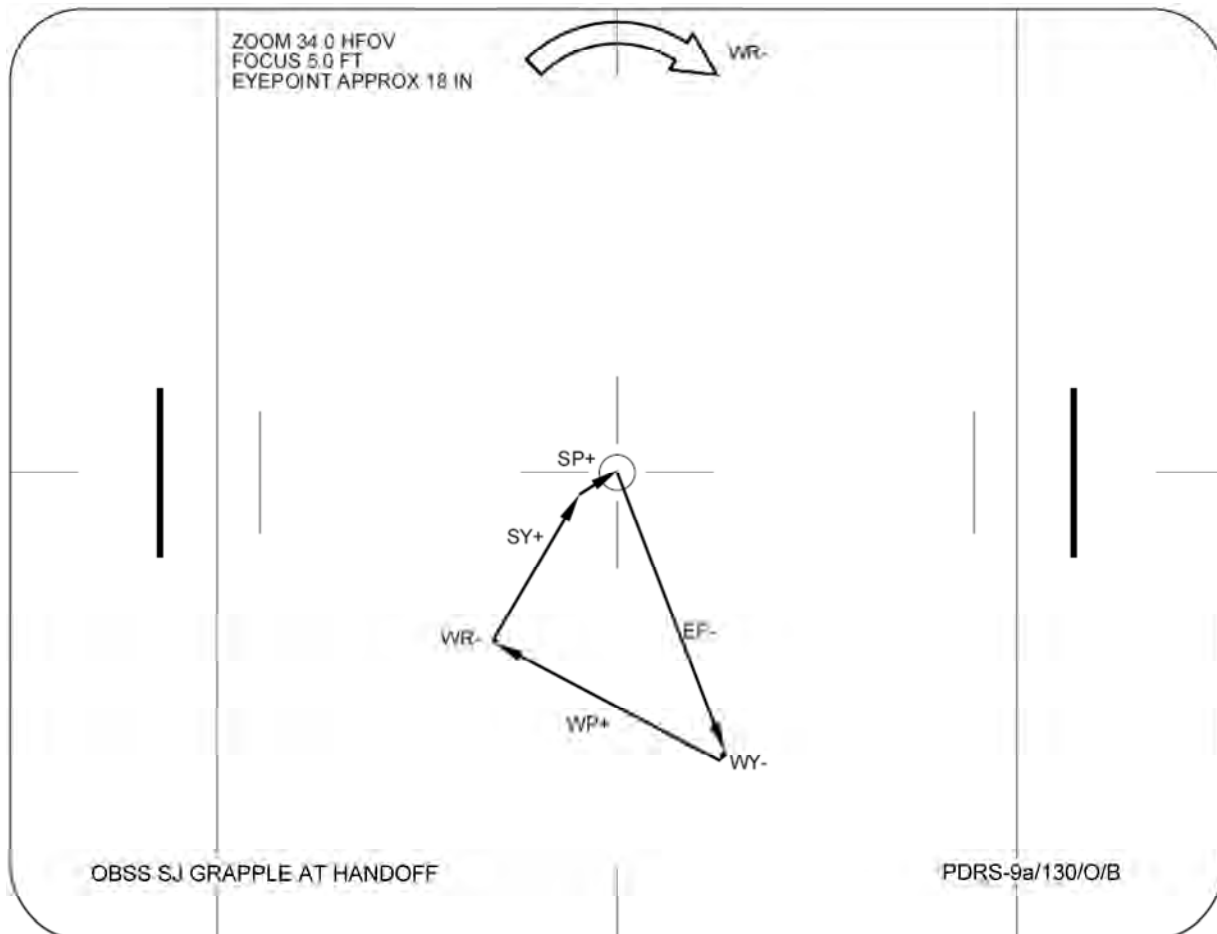

SM 94 PDRS CONTROL

PL ID – ITEM 3 +2 EXEC

INIT ID – ITEM 24 +2 EXEC

Expected OBSS HANDOFF posn:

	X	Y	Z	PITCH	YAW	ROLL	PL ID	
√	-1059	+231	-597	284	270	270	2	*
	SY	SP	EP	WP	WY	WR		
√	+24.5	+59.0	-42.1	-85.9	+11.2	-99.4		

*Display singularity

Give SSRMS Operator GO for OBSS Ungrapple

Review GENERIC END EFFECTOR CUE CARD – ISS/SHUTTLE DOCKED OPS

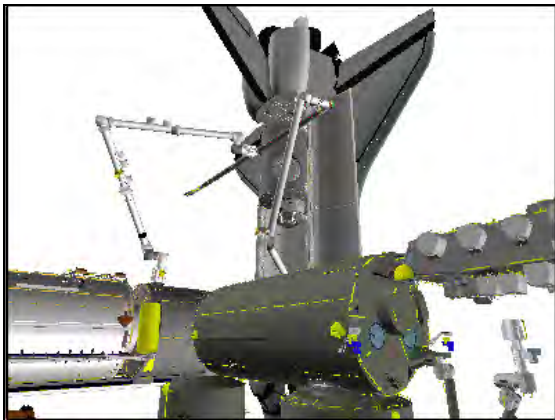

P1 LOOB (130,20)

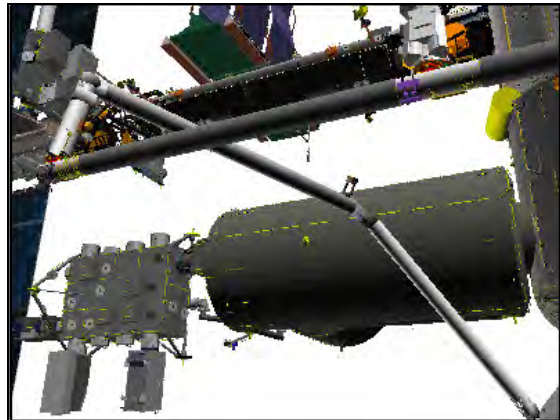

CCTV B (-25,20)



CCTV A (20,25)

R12

Green Jumper – LDRI/ITVC

8. OBSS SENSOR PACKAGE ACTIVATION

Perform ACTIVATION (LDRI/ITVC Cue Card, PHOTO/TV)

LCH ACTIVATION (LCS Cue Card, PHOTO/TV)

LCC ACTIVATION (LCS Cue Card, PHOTO/TV), steps 1 and 2

LCC DEACTIVATION (LCS Cue Card, PHOTO/TV)

9. SINGLE JOINT MNVR TO NODE 3 INSTALL VIEWING POSN
On SSRMS Operator GO for OBSS mnvr to NODE 3 INSTALL VIEWING

R12 Green Jumper – ISS

MON 1 (SSC 1)	A (Elbow)
MON 2 (71)	P1 LOIB (P1 LOOB)
DNLK (72)	B
DTV (SSC 2)	RSC

RHC RATE – as reqd (VERN within 10 ft)
 BRAKES – OFF (tb-OFF)
 MODE – best available

Mnvr to NODE 3 INSTALL VIEWING posn:

OBSS
 HANDOFF
 1: WR +
 2: EP +
 3: WP +
 4: WR +
 5: SP –
 6: SY +
 7: WR +
 NODE 3
 VIEWING

SY	SP	EP	WP	WY	WR	
+24.5	+59.0	-42.1	-85.9	+11.2	-99.4	
					-75.0	
		-20.0				
			-10.0			
					-45.0	
	+44.7					
+64.0						
					+30.0	
+64.0	+44.7	-20.0	-10.0	+11.2	+30.0	
X	Y	Z	PITCH	YAW	ROLL	PL ID
-726	-732	-1148	106	9	282	2

BRAKES – ON (tb-ON)
 MODE – not DIRECT (lt off)
 PARAM – PORT TEMP
 JOINT – CRIT TEMP

10. RECONFIGURE PTU
 Green Jumper – LDRI/ITVC
 DTV ← PL2

R12
 A7U

CAMR CMD PAN/TILT – HI RATE
 PAN – L (to hard stop)
 TILT – UP (to hard stop)
 PAN/TILT – RESET, HI RATE (LO within 10°)
 PAN: +100 (right)
 TILT: -35 (down)

MUX 1 L ← MIDDECK
 LDRI MODE 2 pb – push (ITVC video)
 VIDEO OUT – as desired (not DTV)
 √VIDEO IN – not PL2

Start:
OBSS Handoff Position

Step 1:
Drive WR+ (24.4°)
From -99.4 to -75.0

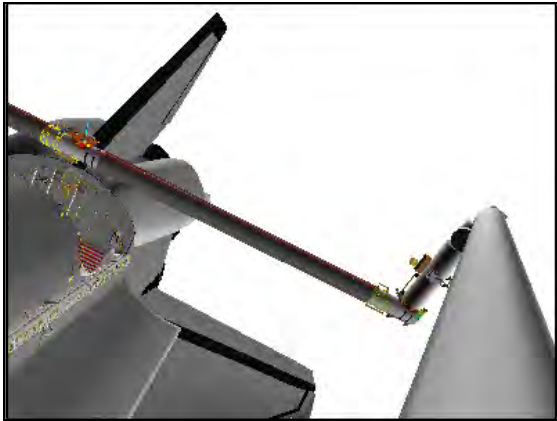

ELBOW (-30,-5)

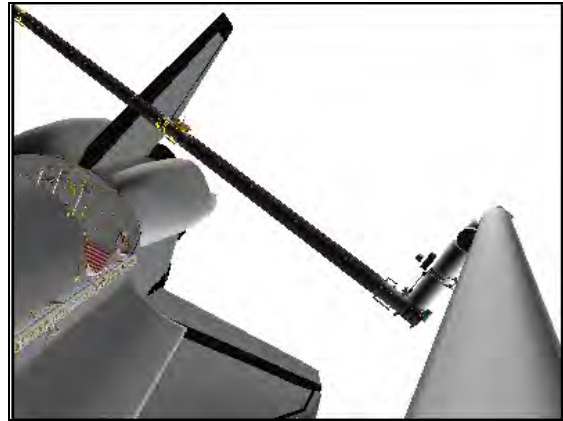

ELBOW (-30,-5)

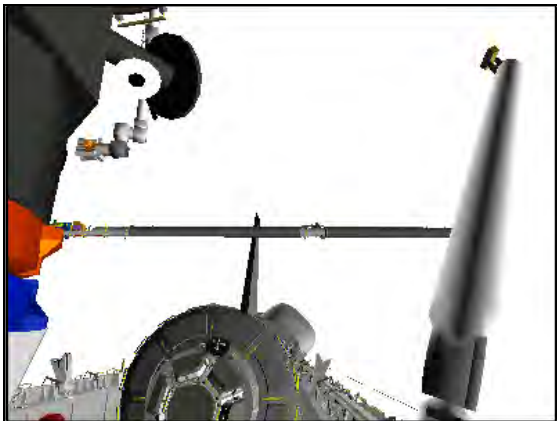

CCTV A (0,20)

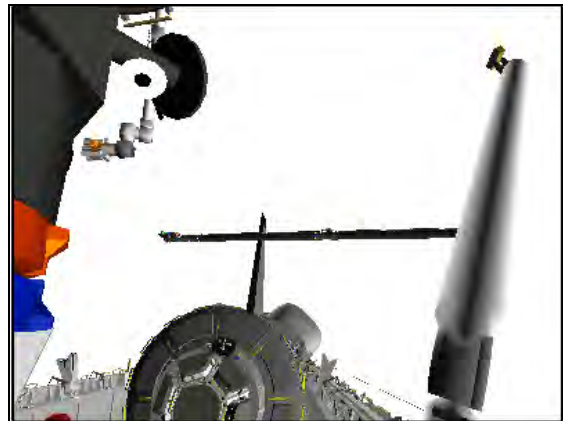

CCTV A (0,20)

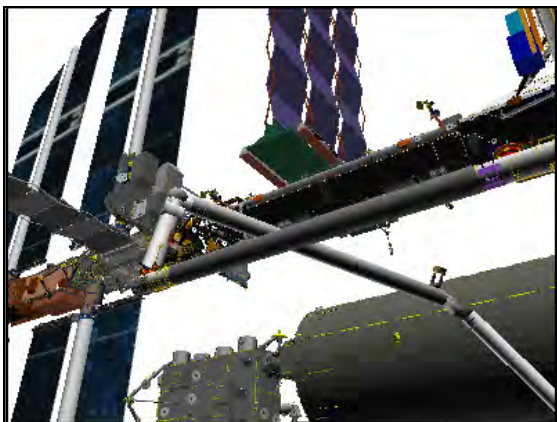

CCTV B (-35,30)

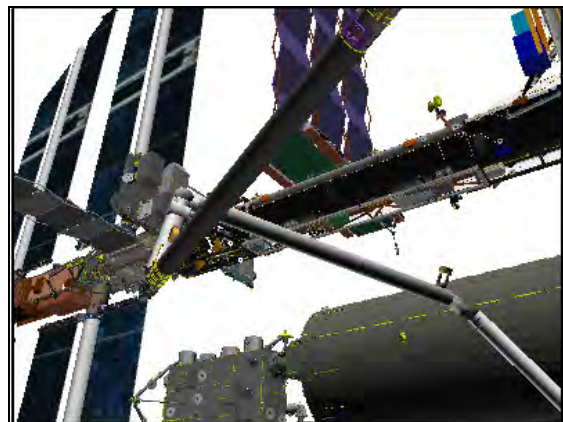

CCTV B (-35,30)

Step 2:

Drive EP+ (22.1°)
From -42.1 to -20.0



ELBOW (-30,-5)

Step 3:

Drive WP+ (75.9°)
From -85.9 to -10.0

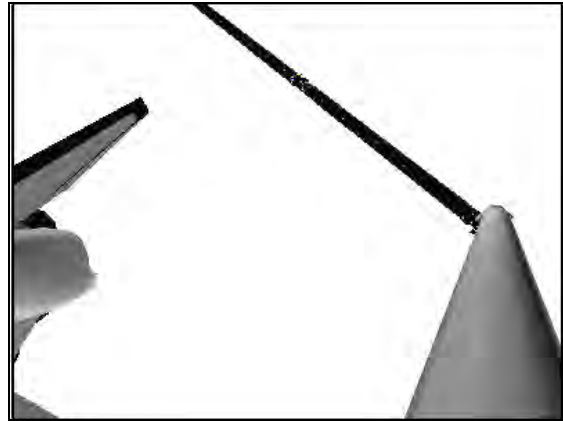

ELBOW (-30,-5)

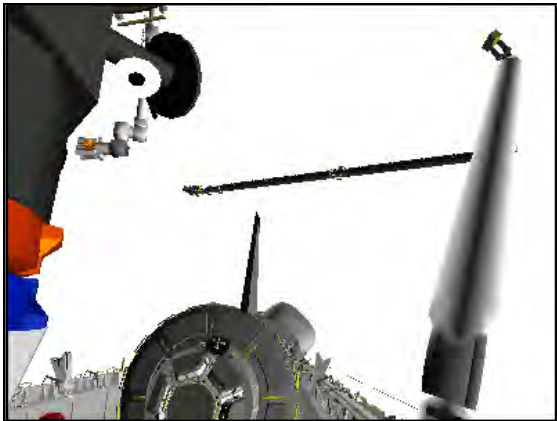

CCTV A (0,20)

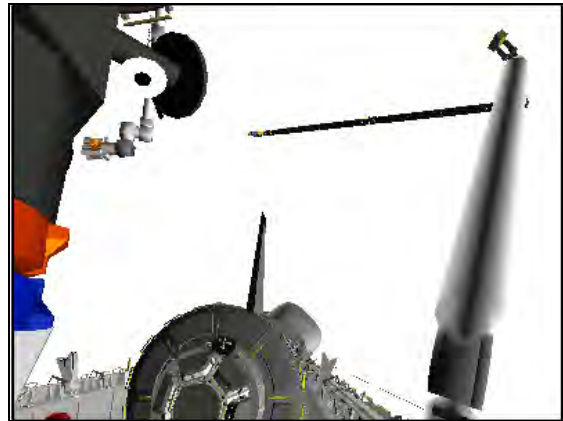

CCTV A (0,20)

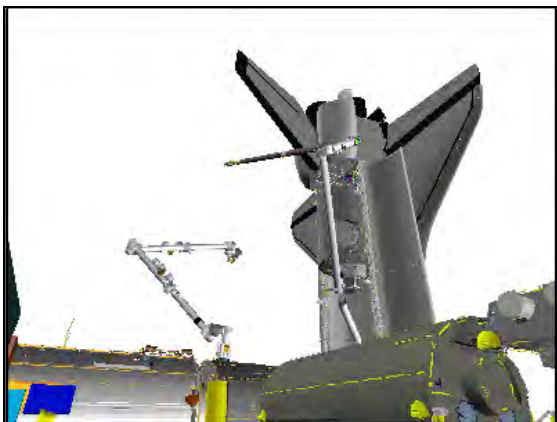

P1 LOOB (120,30)

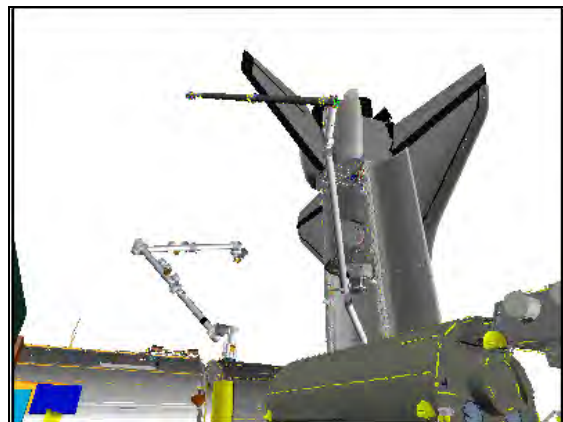

P1 LOOB (120,30)

Step 4:

Drive WR+ (30.0°)
From -75.0 to -45.0



ELBOW (-30,-5)

Step 5:

Drive SP- (14.3°)
From +59.0 to +44.7

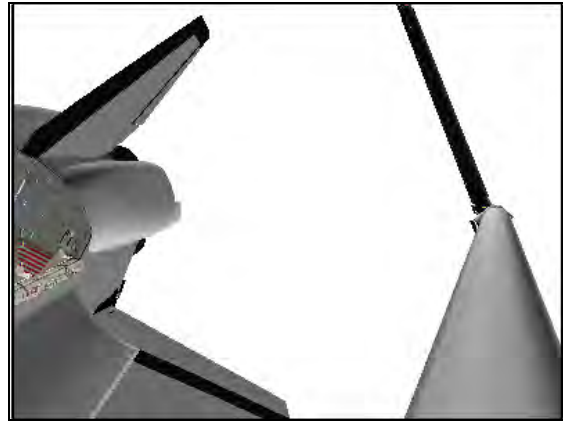

ELBOW (-30,-5)

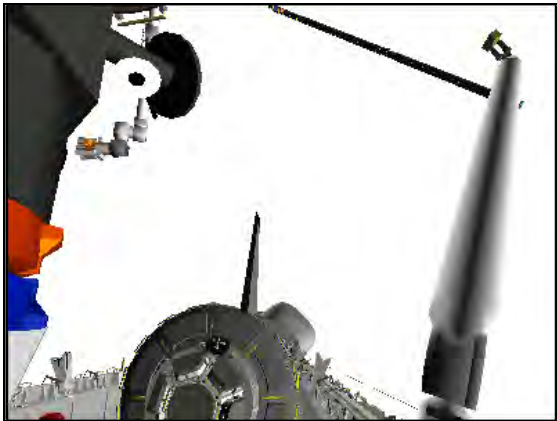

CCTV A (0,20)

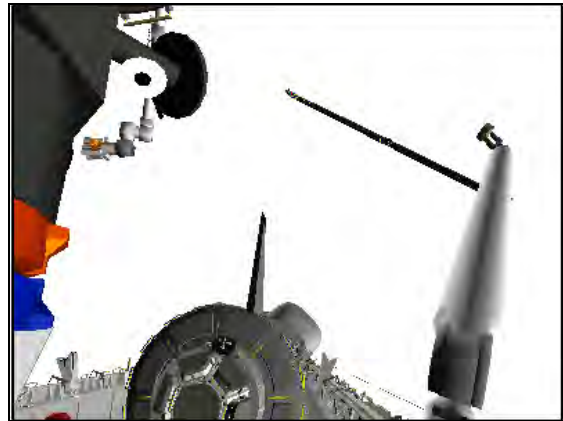

CCTV A (0,20)

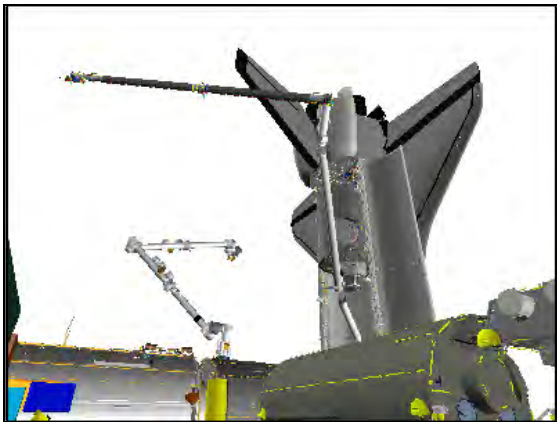

P1 LOOB (120,30)

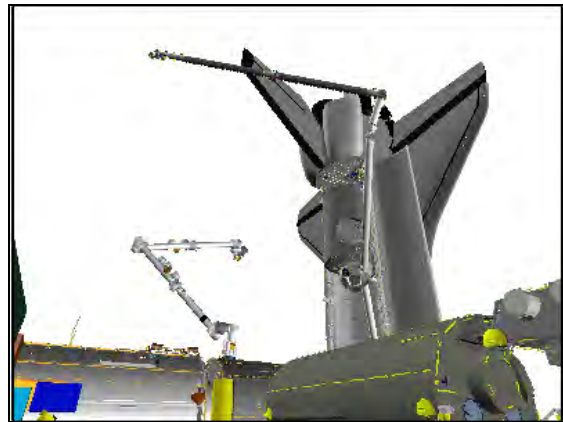

P1 LOOB (120,30)

Step 6:

Drive SY+ (39.5°)
From +24.5 to +64.0

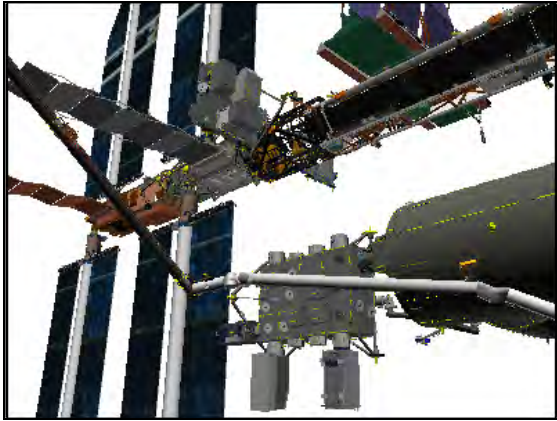

CCTV B (-45,20)

Step 7:

Drive WR+ (75.0°)
From -45.0 to +30.0



CCTV B (-45,20)



CCTV A (40,20)



CCTV A (40,20)

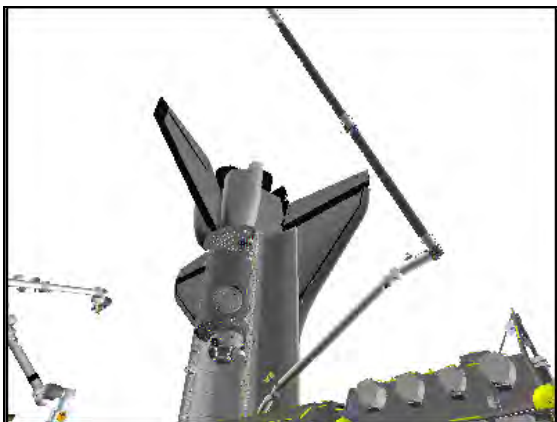

P1 LOOB (140,40)

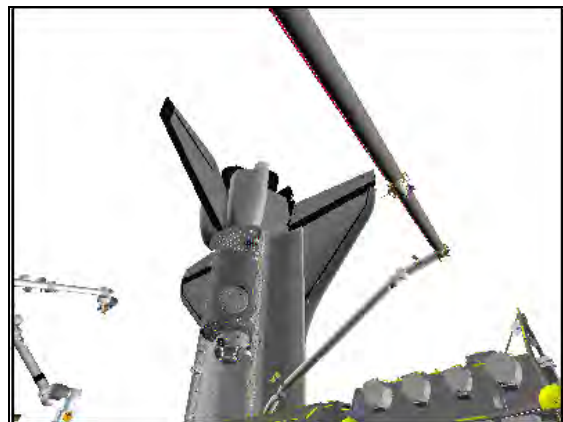

P1 LOOB (140,40)

SJ MNVR TO UNDOCK

1. SETUP

SM 94 PDRS CONTROL

√ PL ID, ITEM 3: 2

√ INIT ID, ITEM 24: 2

Verify at NODE 3 INSTALL VIEWING posn:

	X	Y	Z	PITCH	YAW	ROLL	PL ID
√	-726	-732	-1148	106	9	282	2
	SY	SP	EP	WP	WY	WR	
√	+64.0	+44.7	-20.0	-10.0	+11.2	+30.0	

R12

Green Jumper – ISS

MON 1 (SSC 1)	A (Elbow)
MON 2 (71)	P1 LOIB (P1 LOOB)
DNLK (72)	B
DTV (SSC 2)	RSC

A7U

CCTV – configure as reqd

– perform PAN/TILT RESET for PLB cameras

ZOOM – full OUT

2. SJ OBSS MNVR TO UNDOCK

Verify SSRMS at UNDOCK posn:

SR	SY	SP	EP	WP	WY	WR
+71.0	+170.0	+177.2	+94.0	-41.0	+10.0	+110.8

NOTE

When SY driving, use CCTV D to monitor clearance between OBSS and Orbiter Tail.

When SP driving, minimum clearance between Upper Boom and JEM is 40 inches; use CCTV A to monitor. Minimum clearance between OBSS and SSRMS is 116 inches; use P1 LOOB to monitor

RHC

RATE – as reqd (VERN within 10 ft)

BRAKES – OFF (tb-OFF)

MODE – best available

SM 169 PDRS STATUS

Mnvr to UNDOCK posn:

NODE 3
VIEWING
1: WR -
2: SY -
3: SP +
4: WP -
5: WR -
6: EP -
UNDOCK

SY	SP	EP	WP	WY	WR	
+64.0	+44.7	-20.0	-10.0	+11.2	+30.0	
					-60.0	
+25.8						
	+66.3					
			-85.9			
					-100.7	
		-49.0				
+25.8	+66.3	-49.0	-85.9	+11.2	-100.7	
X	Y	Z	PITCH	YAW	ROLL	PL ID
-1030	+228	-610	284	270	270	2

*Display singularity

BRAKES – ON (tb-ON)
MODE – not DIRECT (lt off)
PARAM – PORT TEMP
JOINT – CRIT TEMP

Start:
Node 3 Viewing Position

Step 1:
Drive WR- (for 90.0°)
From +30.0 to -60.0

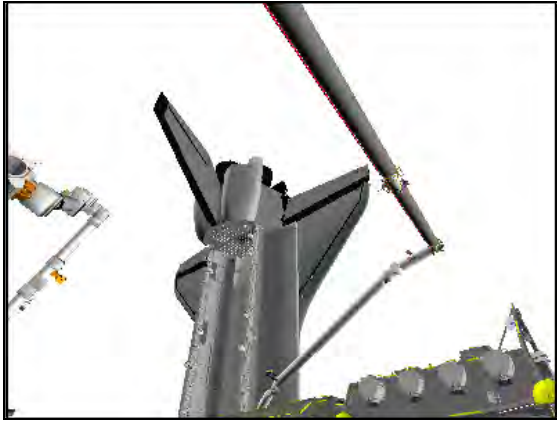

P1 LOOB (140,40)

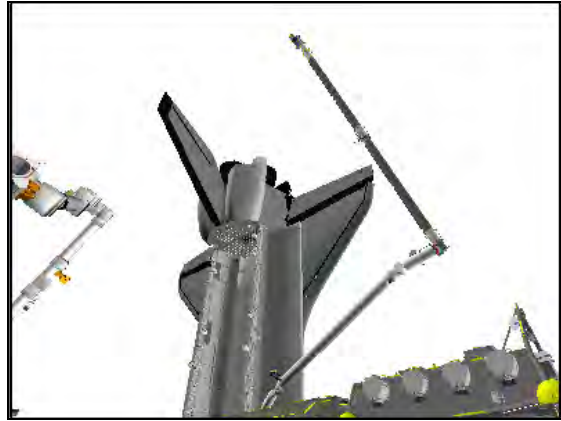

P1 LOOB (140,40)

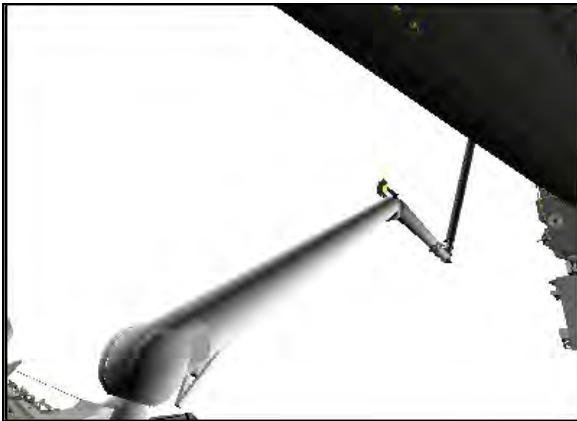

CCTV A (40,20)



CCTV A (40,20)

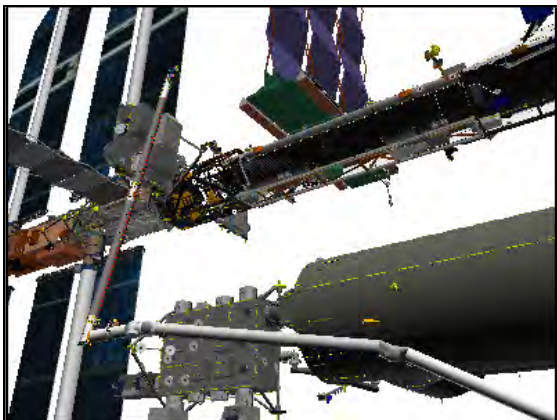

CCTV B (-45,25)



CCTV B (-45,20)

Step 2:

Drive SY- (for 38.2°)
From +64.0 to +25.8

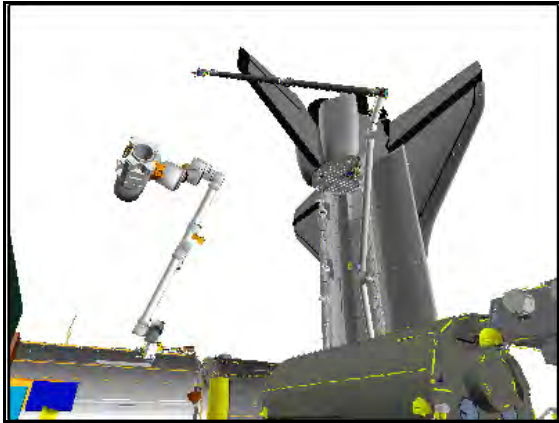

P1 LOOB (120,30)

Step 3:

Drive SP+ (for 21.6°)
From +44.7 to +66.3

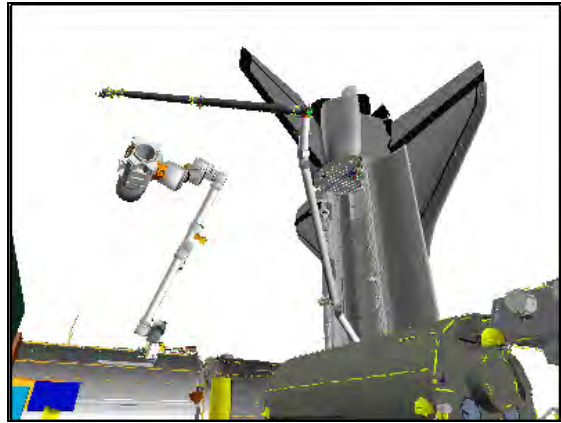

P1 LOOB (120,30)



CCTV A (10,30)



CCTV A (10,30)



CCTV D (10,20)



CCTV D (10,20)

Step 4:

Drive WP- (for 75.9°)
From -10.0 to -85.9



ELBOW (-30,0)

Step 5:

Drive WR- (for 40.7°)
From -60.0 to -100.7

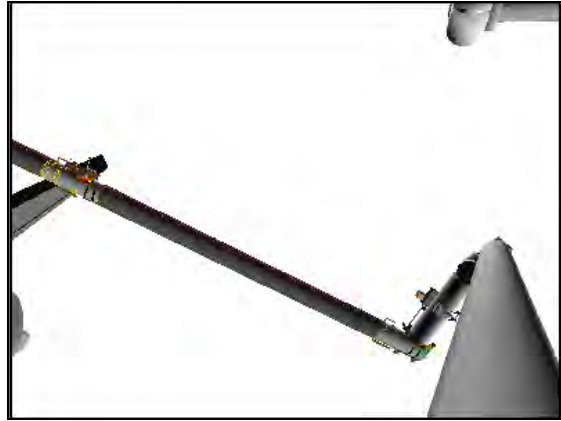

ELBOW (-30,0)



CCTV A (10,30)

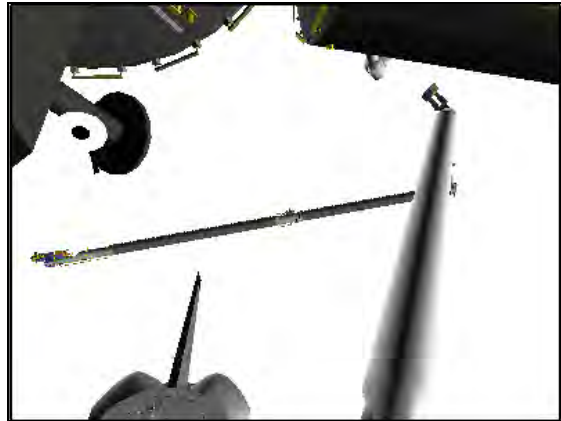

CCTV A (10,30)

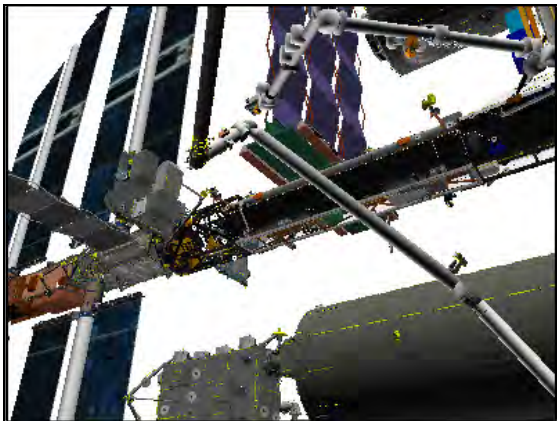

CCTV B (-35,30)



CCTV B (-35,30)

Step 6:

Drive EP- (for 29.0°)

From -20.0 to -49.0

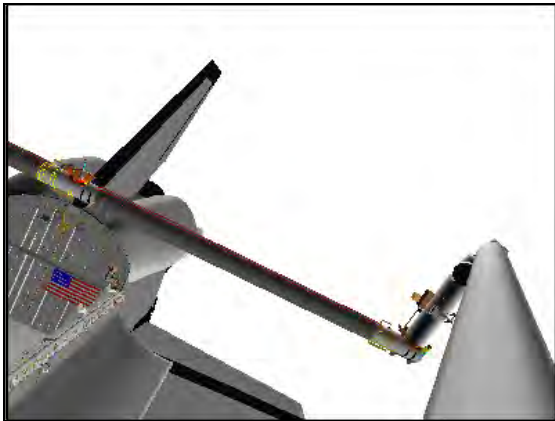

ELBOW (-30,-5)



CCTV A (10,30)



CCTV B (-35,30)

SJ MNVR TO OBSS HOVER

1. SETUP

MON 1 (SSC 1)	B
MON 2 (71)	A
DNLK (72)	ELBOW
DTV (SSC 2)	D

SM 94 PDRS CONTROL

√ PL ID, ITEM 3: 1
 √ INIT ID, ITEM 24: 1

	X	Y	Z	PITCH	YAW	ROLL	PL ID
√	-1041	-362	-602	284	270	270	1
	SY	SP	EP	WP	WY	WR	
√	+25.8	+66.3	-49.0	-85.9	+11.2	-100.7	

*Display singularity

2. SINGLE JOINT TO OBSS HOVER

NOTE

When SY joint is driving, minimum clearance between OBSS and Orbiter Tail is 95 inches. At end of this single joint sequence, OBSS is 66 inches from starboard OMS pod

RHC

BRAKES – OFF (tb-OFF)
 RATE – as reqd (VERN within 10 ft)
 MODE – best available

SM 169 PDRS STATUS

Mnvr to OBSS HOVER posn:

	SY	SP	EP	WP	WY	WR	
Undock posn	+25.8	+66.3	-49.0	-85.9	+11.2	-100.7	
1: WY –					0.0		
2: WP +				-59.8			
3: WR +						+110.0	
4: SY –	-90.0						
5: SP +		+80.2					
6: EP –			-118.8				
OBSS Hover	-90.0	+80.2	-118.8	-59.8	0.0	+110.0	
	X	Y	Z	PITCH	YAW	ROLL	PL ID
	-680	+133	-517	0	0	341	1

BRAKES – ON (tb-ON)
 MODE – not DIRECT (It off)
 PARAM – PORT TEMP
 JOINT – CRIT TEMP

If berthing OBSS, perform OBSS SJ BERTH (PDRS, OBSS OPS)

Start:
Undock Position

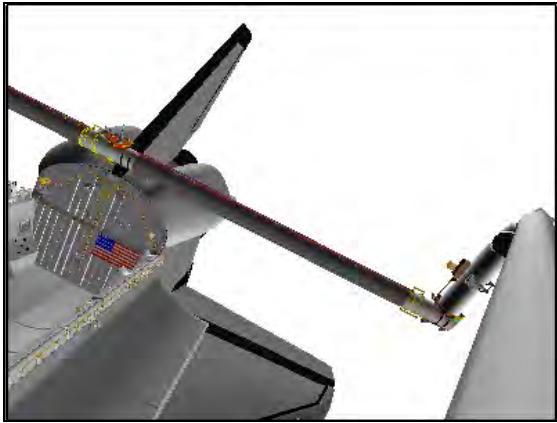

ELBOW (-35,-5)

Step 1:
Drive WY- (for 11.2°)
From +11.2 to 0.0

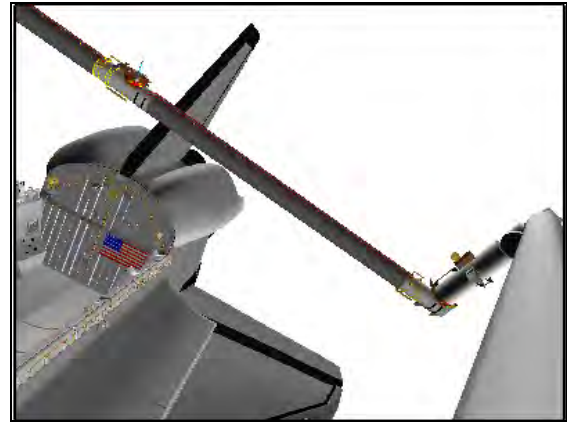

ELBOW (-35,-5)



CCTV A (10,25)

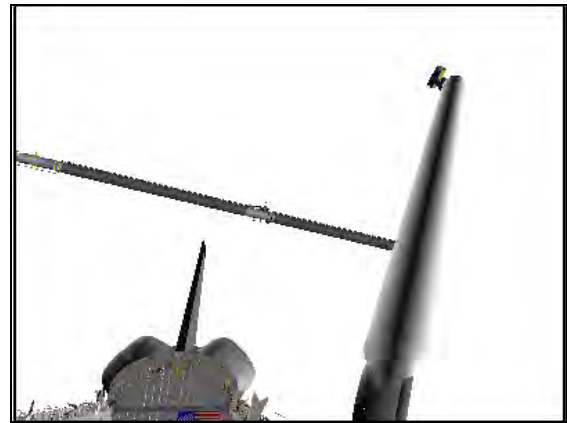

CCTV A (10,25)



CCTV B (-20,20)



CCTV B (-20,20)

Step 2:

Drive WP+ (for 26.1°)
From -85.9 to -59.8



ELBOW (-35,-5)

Step 3:

Drive WR+ (for 210.7°)
From -100.7 to +110.0



ELBOW (5,-30)



CCTV A (10,25)



CCTV A (45,25)



CCTV B (-20,20)



CCTV B (-35,20)

Step 4:

Drive SY- (for 115.8°)
From +25.8 to -90



CCTV D (15,60)

Step 5:

Drive SP+ (for 13.9°)
From +66.3 to +80.2



CCTV D (15,60)



CCTV A (-25,45)



CCTV A (-25,45)

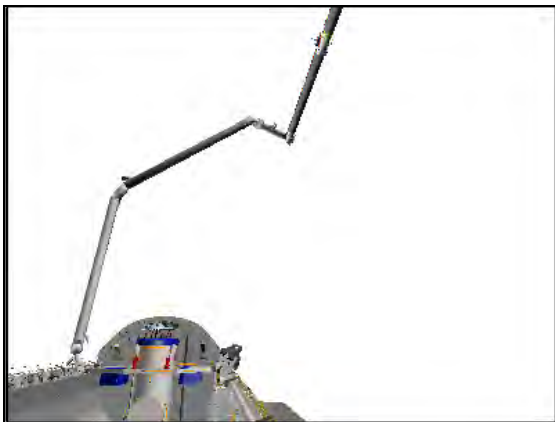

CCTV C (10,20)

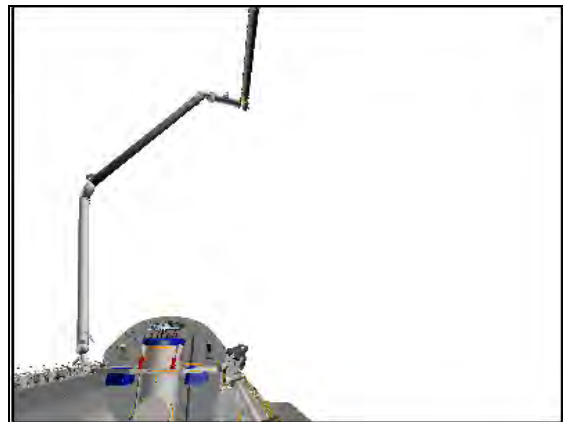

CCTV C (10,20)

Step 6:

Drive EP- (for 69.8°)
From -49.0 to -118.8



CCTV D (-5,20)

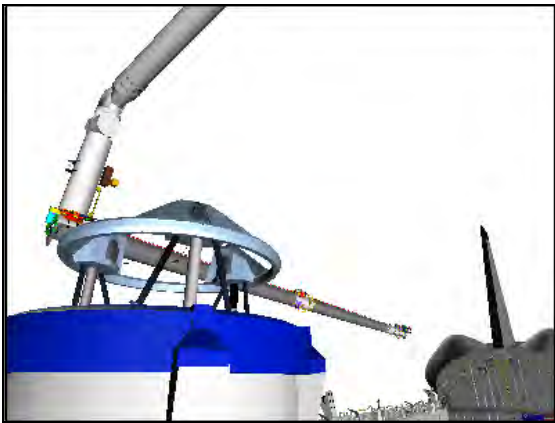

CCTV A (-35,25)



CCTV C (10,20)

REFERENCE DATA

JOINT ANGLES VS POR COORDINATES FS 3-2

REFERENCE
DATA

JOINT ANGLES VS POR COORDINATES

OBSS HANDOFF PRE-GRAPPLE posn:

X	Y	Z	PITCH	YAW	ROLL	PL ID
-1047	-360	-658	+284	0	+270	0
-1056	-360	-642	+284	+270	+270	1
-1045	+231	-656	+284	+270	+270	2
SY	SP	EP	WP	WY	WR	
+22.7	+57.5	-27.5	-99.2	+11.7	-97.7	

*Display singularity

OBSS HANDOFF posn:

X	Y	Z	PITCH	YAW	ROLL	PL ID
-1062	-360	-600	+284	0	+270	0
-1070	-360	-584	+284	+270	+270	1
-1059	+231	-597	+284	+270	+270	2
SY	SP	EP	WP	WY	WR	
+24.5	+59.0	-42.1	-85.9	+11.2	-99.4	

*Display singularity

NODE 3 INSTALL VIEWING posn:

X	Y	Z	PITCH	YAW	ROLL	PL ID
-890	-643	-587	+342	+75	+36	0
-890	-661	-584	+106	+9	+252	1
-726	-732	-1148	+106	+9	+282	2
SY	SP	EP	WP	WY	WR	
+64.0	+44.7	-20.0	-10.0	+11.2	+30.0	

UNDOCK posn:

X	Y	Z	PITCH	YAW	ROLL	PL ID
-1032	-363	-618	+284	+0	+270	0
-1041	-363	-602	+284	+270	+270	1
-1030	+228	-610	+284	+270	+270	2
SY	SP	EP	WP	WY	WR	
+25.8	+66.3	-49.0	-85.9	+11.2	-100.7	

*Display singularity

FLAT FIELD posn:

X	Y	Z	PITCH	YAW	ROLL	PL ID
-679	+351	-448	+270	+349	+1	0
-679	+350	-430	0	0	+11	1
-1270	+350	-445	0	0	+11	2
SY	SP	EP	WP	WY	WR	
-90.1	+25.0	-65.8	-57.6	0.0	-249.9	

REFERENCE
DATA

CUE CARD CONFIGURATION

OBSS SJ GRAPPLE AT HANDOFF FS CC 4-2

CUE CARD
CONFIG

CUE CARD
CONFIG

Fabricate as transparency

ZOOM 34.0 HFOV
FOCUS 5.0 FT
EYEPOINT APPROX 18 IN

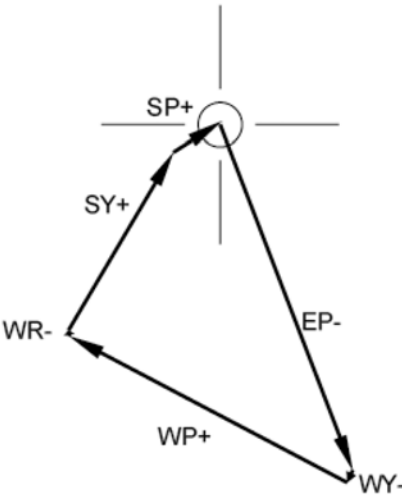

OBSS SJ GRAPPLE AT HANDOFF

PDRS-9a/130/O/B

I

(reduced copy)

FS CC 4-2

PDRS/130/FIN



PDRS OPS C/L

**STS
130**