

PDRS Operations Checklist

STS-132 Flight Supplement

**Mission Operations Directorate
EVA, Robotics, & Crew Systems
Operations Division**

**Final
March 23, 2010**

National Aeronautics and
Space Administration

Lyndon B. Johnson Space Center
Houston, Texas

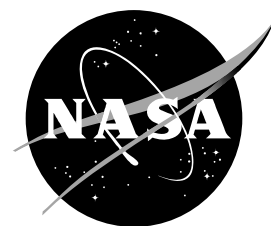

PDRS OPS CHECKLIST 132 FLT SUPPL

FINAL (Mar 23, 2010)

PCN-1 (Apr 23, 2010) Sheet 1 of 1

List of Implemented Change Requests (482s):

PDRS FS-00189A

PDRS FS-00190A

Incorporate the following:

1. Replace FS iii thru FS vi
2. Replace FS 5-1 and FS 5-2
After FS 5-14, add FS 5-15 thru FS 5-18
3. Replace FS 6-5 and FS 6-6

Prepared by:

Book Manager

Approved by:

Lead, Shuttle and Exploration Robotics
Operations Group

Accepted by:

Chief, Robotics Operations Branch

Encl: 12 pages

File this PCN immediately behind the front cover as a permanent record

MISSION OPERATIONS DIRECTORATE

**PDRS OPERATIONS CHECKLIST
STS-132 FLIGHT SUPPLEMENT**

FINAL
March 23, 2010

PREPARED BY:

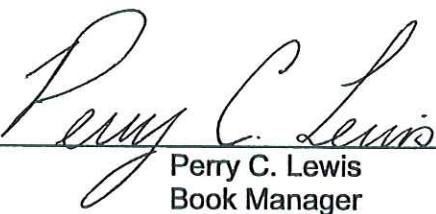

Perry C. Lewis
Book Manager

APPROVED BY:



Aaron D. Goldenthal
Lead, Shuttle and Exploration Robotics
Operations Group



Quinn L. Carelock
Chief, Robotics Operations Branch

This document is under the configuration control of the Crew Procedures Control Board (CPCB). All proposed changes must be submitted via Change Request Workflow (CRW) to DO3/FDF Manager.

Additional distribution of this book, for official use only, may be requested in writing to DO3/PMO Administrator. The request must include justification and requester's name, organization, position, and phone number. Contractor requests are made through the NASA or DOD organization supported. Deletions, reduction in quantity, or change of address may be submitted to DO3/FDF Management Office, 281-244-1184.

Incorporates the following:		
482#:	PDRS_FS-00162	PDRS_FS-00183
	PDRS_FS-00163	PDRS_FS-00184
	PDRS_FS-00164	PDRS_FS-00185
	PDRS_FS-00165	PDRS_FS-00186
	PDRS_FS-00166	PDRS_FS-00187
	PDRS_FS-00168	PDRS_FS-00188

AREAS OF TECHNICAL RESPONSIBILITY

Book Manager/Mission Designer	DX22/P. Lewis	281-483-6273
Lead PDRS	DX22/T. Smith	281-483-1595
Lead Analyst	DX24/M. Tremblay	281-244-1107
Mission Designer	DX26/D. Klein	281-483-9413

PDRS OPERATIONS CHECKLIST
 STS-132 FLIGHT SUPPLEMENT

LIST OF EFFECTIVE PAGES

FINAL 03/23/10
 PCN-1 04/23/10

Sign Off.....*	132/FIN	FS 4-3.....⊗	132/FIN
FS ii.....*	132/FIN	FS 4-4.....⊗	132/FIN
FS iii.....*	132/FIN 1	FS 4-5.....⊗	132/FIN
FS iv.....*	132/FIN 1	FS 4-6.....	132/FIN
FS v.....	132/FIN 1	FS 4-7.....	132/FIN
FS vi.....	132/FIN	FS 4-8.....⊗	132/FIN
FS 1-1.....	132/FIN	FS 4-9.....⊗	132/FIN
FS 1-2.....	132/FIN	FS 4-10.....	132/FIN
FS 1-3.....⊗	132/FIN	FS 4-11.....	132/FIN
FS 1-4.....	132/FIN	FS 4-12.....⊗	132/FIN
FS 1-5.....⊗	132/FIN	FS 4-13.....	132/FIN
FS 1-6.....	132/FIN	FS 4-14.....⊗	132/FIN
FS 1-7.....	132/FIN	FS 4-15.....⊗	132/FIN
FS 1-8.....	132/FIN	FS 4-16.....⊗	132/FIN
FS 1-9.....⊗	132/FIN	FS 4-17.....	132/FIN
FS 1-10.....⊗	132/FIN	FS 4-18.....	132/FIN
FS 1-11.....	132/FIN	FS 4-19.....⊗	132/FIN
FS 1-12.....	132/FIN	FS 4-20.....	132/FIN
FS 1-13.....⊗	132/FIN	FS 4-21.....⊗	132/FIN
FS 1-14.....	132/FIN	FS 4-22.....	132/FIN
FS 1-15.....⊗	132/FIN	FS 4-23.....⊗	132/FIN
FS 1-16.....	132/FIN	FS 4-24.....⊗	132/FIN
FS 2-1.....	132/FIN	FS 4-25.....⊗	132/FIN
FS 2-2.....	132/FIN	FS 4-26.....⊗	132/FIN
FS 2-3.....⊗	132/FIN	FS 4-27.....⊗	132/FIN
FS 2-4.....	132/FIN	FS 4-28.....	132/FIN
FS 2-5.....	132/FIN	FS 4-29.....⊗	132/FIN
FS 2-6.....⊗	132/FIN	FS 4-30.....⊗	132/FIN
FS 2-7.....	132/FIN	FS 4-31.....	132/FIN
FS 2-8.....⊗	132/FIN	FS 4-32.....⊗	132/FIN
FS 2-9.....	132/FIN	FS 4-33.....⊗	132/FIN
FS 2-10.....⊗	132/FIN	FS 4-34.....⊗	132/FIN
FS 2-11.....	132/FIN	FS 5-1.....	132/FIN 1
FS 2-12.....	132/FIN	FS 5-2.....	132/FIN
FS 3-1.....	132/FIN	FS 5-3.....⊗	132/FIN
FS 3-2.....	132/FIN	FS 5-4.....⊗	132/FIN
FS 3-3.....⊗	132/FIN	FS 5-5.....⊗	132/FIN
FS 3-4.....	132/FIN	FS 5-6.....⊗	132/FIN
FS 3-5.....⊗	132/FIN	FS 5-7.....	132/FIN
FS 3-6.....	132/FIN	FS 5-8.....	132/FIN
FS 3-7.....⊗	132/FIN	FS 5-9.....	132/FIN
FS 3-8.....	132/FIN	FS 5-10.....⊗	132/FIN
FS 4-1.....	132/FIN	FS 5-11.....	132/FIN
FS 4-2.....	132/FIN	FS 5-12.....	132/FIN
		FS 5-13.....⊗	132/FIN
		FS 5-14.....	132/FIN

* – Omit from flight book

⊗ – Flight copies of this page contain color

FS 5-15	⊗	132/FIN 1
FS 5-16		132/FIN 1
FS 5-17	⊗	132/FIN 1
FS 5-18		132/FIN 1
FS 6-1		132/FIN
FS 6-2		132/FIN
FS 6-3		132/FIN
FS 6-4	⊗	132/FIN
FS 6-5	⊗	132/FIN
FS 6-6		132/FIN 1
FS 6-7		132/FIN
FS 6-8		132/FIN
FS 7-1	*	132/FIN
FS CC 7-2	*	132/FIN
FS CC 7-3	*	132/FIN
FS CC 7-4	*	132/FIN
FS CC 7-5	*	132/FIN
FS 7-6	*	132/FIN

PDRS CUE CARDS

<u>Title</u>	<u>Ref. Page</u>	<u>Card No.</u>
OVERLAY FOR ROEU PL SEL POSITION.....	FS CC 7-2	PDRS-9a/132/O/A
SJ MRM1 GRAPPLE – CCTV OVERLAY.....	FS CC 7-3	PDRS-10a/132/O/A
SJ MRM1 RELEASE AT HANDOFF – CCTV OVERLAY	FS CC 7-4	PDRS-11a/132/O/A
OBSS SJ GRAPPLE AT HANDOFF	FS CC 7-5	PDRS-12a/132/O/A

⊗ – Flight copies of this page contain color

* – Omit from flight book

<u>CONTENTS</u>	<u>PAGE</u>
<u>MRM1 NOMINAL</u>	FS 1-1
MRM1 PRE-GRAPPLE	FS 1-2
GRAPPLE	FS 1-4
UNBERTH	FS 1-6
RELEASE	FS 1-11
DOCK VIEWING	FS 1-14
 <u>OBSS NOMINAL</u>	 FS 2-1
MNVR TO OBSS HANDOFF PRE-GRAPPLE	FS 2-2
OBSS GRAPPLE FROM SSRMS	FS 2-5
MNVR TO OBSS UNDOCK	FS 2-7
OBSS MNVR TO FLAT FIELD	FS 2-9
 <u>VIEWING SUPPORT</u>	 FS 3-1
ICC UNBERTH VIEWING	FS 3-2
SGANT & EOTP VIEWING	FS 3-4
BATTERY R&R VIEWING	FS 3-6
 <u>MRM1 OFF-NOMINAL</u>	 FS 4-1
SJ MRM1 PRE-GRAPPLE	FS 4-2
GRAPPLE	FS 4-6
UNBERTH	FS 4-10
RELEASE	FS 4-17
MRM1 CONTINGENCY REBERTH	FS 4-22
PROBE REMOVAL	FS 4-31
 <u>OBSS OFF-NOMINAL</u>	 FS 5-1
SJ OBSS GRAPPLE FROM SSRMS	FS 5-2
OBSS HANDBACK TO SSRMS	FS 5-11
BATTERY R&R VIEWING TO OBSS SENSOR PROTECT	FS 5-15
OBSS SENSOR PROTECT TO BATTERY R&R VIEWING	FS 5-17
 <u>REFERENCE DATA</u>	 FS 6-1
MRM1 JOINT ANGLES VS POR COORDINATES	FS 6-2
COORDINATE SYSTEM – PL ID 3	FS 6-4
PRLA CONFIGURATION	FS 6-5
OBSS JOINT ANGLES VS POR COORDINATES	FS 6-6
VIEWING JOINT ANGLES VS POR COORDINATES	FS 6-7
 <u>CUE CARD CONFIGURATION</u>	 FS 7-1

This Page Intentionally Blank

MRM1 NOMINAL

MRM1 PRE-GRAPPLE.....	FS 1-2
GRAPPLE	FS 1-4
UNBERTH.....	FS 1-6
RELEASE.....	FS 1-11
DOCK VIEWING	FS 1-14

**MRM1
NOMINAL**

MRM1 PRE-GRAPPLE

MRM1
NOMINAL

1. SETUP

SM 94 PDRS CONTROL

√ PL ID, ITEM 3: 0

√ INIT ID, ITEM 24: 0

Verify SRMS at SGANT & EOTP VIEWING posn:

X	Y	Z	PITCH	YAW	ROLL	PL ID
-820	-493	-764	159	7	0	0
SY	SP	EP	WP	WY	WR	
+53.0	+62.0	-23.0	+107.0	+48.0	+64.0	

V10/L	D
V10/R	Elbow
MON 1	B
MON 2	A

SM 94 PDRS CONTROL

END POS – ITEM 18 -1 1 4 1 +0 -5 2 5 EXEC

ATT – ITEM 21 +3 1 0 +0 +0 EXEC

CMD CK – ITEM 25 EXEC (GOOD)

2. MNVR TO MRM1 PRE-GRAPPLE POSN

On SSRMS Operator GO for MNVR TO MRM1 PRE-GRAPPLE posn,

RHC

RATE – as reqd (VERN within 10 ft)

BRAKES – OFF (tb-OFF)

MODE – SINGLE, ENTER

Mnvr to MRM1 INTERMEDIATE PRE-GRAPPLE posn:

SY	SP	EP	WP	WY	WR	
+53.0	+62.0	-23.0	+107.0	+48.0	+64.0	
	+50.0					
+20.0						
			0.0			
+20.0	+50.0	-23.0	0.0	+48.0	+64.0	
X	Y	Z	PITCH	YAW	ROLL	PL ID
-1098	-408	-705	357	72	74	0

RHC

RATE – VERN (RATE MIN tb-ON)

MODE – OPR CMD, ENTER (READY lt on)

AUTO SEQ – PROCEED (IN PROG lt on)

When AUTO SEQ IN PROG lt – off:

BRAKES – ON (tb-ON)

MRM1 PRE-GRAPPLE posn: (01:15)

	X	Y	Z	PITCH	YAW	ROLL	PL ID
√	-1141	0	-525	310	0	0	0
	SY	SP	EP	WP	WY	WR	
√	-18.5	+47.6	-66.9	-34.4	+26.6	+22.1	

PARAM – PORT TEMP
JOINT – CRIT TEMP

Notify SSRMS Operator SRMS at MRM1 PRE-GRAPPLE posn

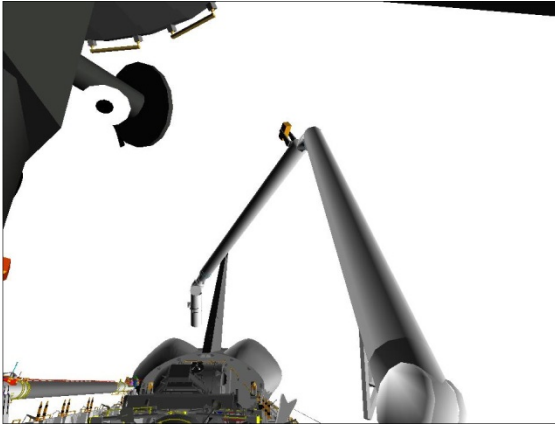

CCTV A (5,25)

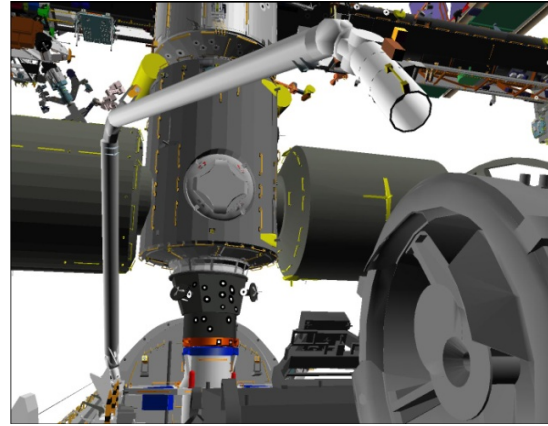

CCTV B (15,15)

MRM1 GRAPPLE

1. SETUP FOR MRM1 GRAPPLE

Verify SSRMS at MRM1 PRE-GRAPPLE posn:

SR	SY	SP	EP	WP	WY	WR
-39.8	+90.2	-17.2	+45.0	-68.1	-142.9	+58.3

Verify SRMS at MRM1 PRE-GRAPPLE posn:

X	Y	Z	PITCH	YAW	ROLL	PL ID
-1141	0	-525	310	0	0	0
SY	SP	EP	WP	WY	WR	
-18.5	+47.6	-66.9	-34.4	+26.6	+22.1	

R12 √Green Jumper – ISS

V10/L	D
V10/R	P1 LOOB
MON 1	EE
MON 2	A

A7U

CCTV – config for grapple

– install PDRS TARGET OVERLAY FOR CTVM

– RMS WRIST, ZOOM: 34.0 HFOV

FOCUS: 5 ft

Maintain eyepoint approx 18 in when using grapple overlay

2. MRM1 GRAPPLE

Notify SSRMS Operator SRMS MRM1 Grapple in work

RHC

√RATE – VERN (RATE MIN tb-ON)

BRAKES – OFF (tb-OFF)

MODE – END EFF, ENTER







Mnvr to grapple envelope

<u>CAUTION</u>
Monitor EE tb timing to prevent EE motor burnout

SM 169 PDRS STATUS

EE MODE – AUTO

CAPTURE sw – depress (mom)

√	RIGID	CLOSE	CAPTURE
	DERIGID	OPEN	EXTEND
			
			

CRITICAL TIMES (28 sec total):

CAPTURE tb – gray, then

CLOSE tb – gray, 3 sec max, then

RIGID tb – gray, 25 sec max

EE MODE – OFF

- * If manual capture required: *
- * EE MODE – MAN *
- * CAPTURE sw – depress (hold until CLOSE tb-gray, 3 sec max) *
- * MAN CONTR – RIGID (hold until RIGID tb-gray, 25 sec max) *
- * MODE – OFF *

BRAKES – ON (tb-ON)

SM 94 PDRS CONTROL

PL ID – ITEM 3 +3 EXEC

INIT ID – ITEM 24 +3 EXEC

Record POS/ATT and Joint Angles:

	X	Y	Z	PITCH	YAW	ROLL	PL ID
							3
Expected	-1116	0	-414	0	0	0	3
	SY	SP	EP	WP	WY	WR	
Expected	-14.8	+33.1	-53.1	-32.4	+24.3	+19.3	

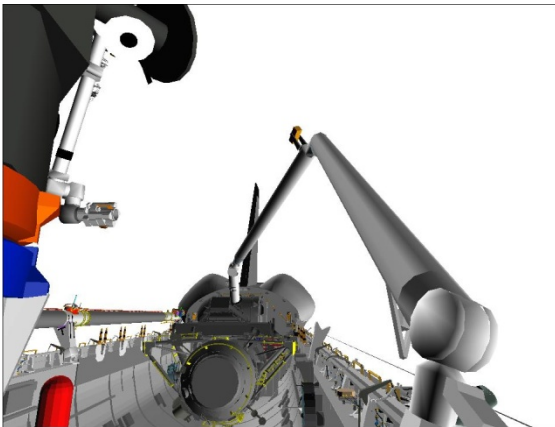

CCTV A (0,15)

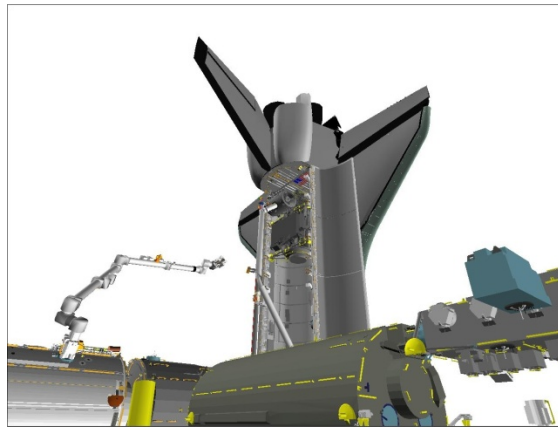

P1 LOOB (130,30)

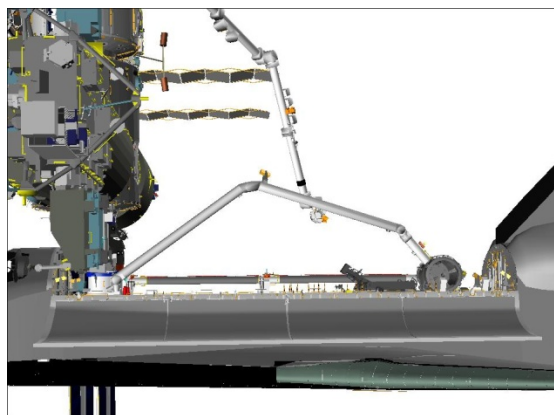

PORT

Review GENERIC END EFFECTOR CUE CARD – ISS/SHUTTLE DOCKED OPS

MRM1 UNBERTH

1. SETUP

V10/L	Elbow
V10/R	SSRMS Tip Elbow (P1 LOIB)
MON 1	B/C Mux
MON 2	D/A Mux

PCS

MSS: SSRMS: Thrusters:

Verify 'Desat Request:' Inhibit
 'Auto Att Control Handover to RS:' Inhibit

- * If using shuttle attitude control: *
- * Verify in attitude, then DAP: FREE *

2. MRM1 PREP FOR TRANSFER

On MCC GO for MRM1 Unberth,

Perform 1.102 MRM1 PREP FOR TRANSFER (ASSY OPS, MRM1)

3. ROEU

CCTV – Config for ROEU demate

A6U

3.1 Deadface ROEU

Install ROEU A6U PANEL OVERLAY

√ PL RETEN LAT (five) – OFF
 PL SEL – 2

√ PL SEL 2 REL 2,3 (four): 0

- * If any REL msw shows '1', expect *
- * single motor time *

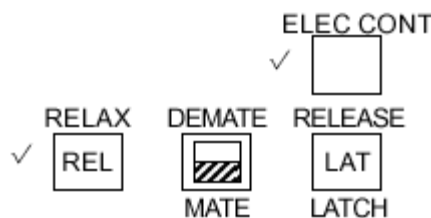

3.2 Activate ROEU

NOTE

When MCA LOGIC switches taken OFF, KU will mode to standby. MPM and MRL tbs – bp

MA73C:A
 :B

MCA LOGIC MNC MID 2 – OFF
 MNB MID 4 – OFF

A6U
 R13L

PL RETEN LOGIC PWR SYS 1,2 (two) – ON
 BAY MECH PWR SYS 1,2 (two) – ON

3.3 Release Latches

Note single motor time (> 20 sec)

A6U

RELEASE/LATCH – REL (tb-REL), 40 sec max
– OFF

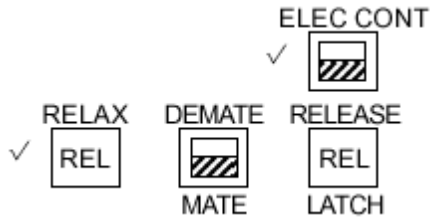

3.4 Demate ROEU

Note single motor time (> 18 sec)

DEMATE/MATE – DEMATE (tb-REL), 36 sec max
– OFF

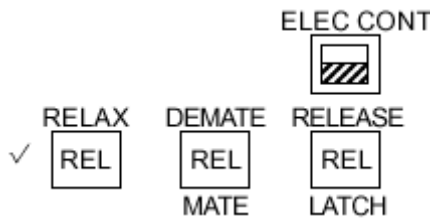

Remove ROEU A6U PANEL OVERLAY

4. ACTIVATE LATCHES

PL RETEN PL SEL – 3

SM 97 PL RETENTION

√PL SEL 3 RDY-FOR-LAT 1,2,3,4,5 (ten): 1
√REL 1,2,3,4,5 (ten) : 0

- * If any REL msw shows '1', expect *
- * single motor time (60 sec) *

5. AKA RELEASE

A6U

√PL RETEN LAT 5 tb – LAT
√RDY 5 tb – gray

Note single motor time (> 30 sec)

PL RETEN LAT 5 – REL (tb-REL), 60 sec max
– OFF

6. PRLA RELEASE

- √PL RETEN LAT 1,2,3,4 tb (four) – LAT
- √RDY 1,2,3,4 tb (four) – gray

Note single motor times (> 30 sec)

- PL RETEN LAT 1,2 (two) – REL (tb-REL), 60 sec max
- OFF
- 3,4 (two) – REL (tb-REL), 60 sec max
- OFF

7. DEACTIVATE LATCHES

- R13L PL RETEN LOGIC PWR SYS 1,2 (two) – OFF
- BAY MECH PWR SYS 1,2 (two) – OFF

- MA73C:A MCA LOGIC MNC MID 2 – ON
- :B MNB MID 4 – ON

Record POS/ATT and Joint Angles:

X	Y	Z	PITCH	YAW	ROLL	PL ID
						3
SY	SP	EP	WP	WY	WR	

8. MNVR TO MRM1 LOW HOVER POSN

NOTE

Minimum clearance between stbd trunnions and OBSS during unberth is expected to be 3.4 inches at approximately Z = -442 (REL = 12). Monitor with SSRMS Tip Elbow Camera.

Minimum clearance between MRM1 probe and aft bulkhead structure during unberth is approximately 18 inches. Monitor with Camera B after MRM1 is clear of V-guides

- RHC √RATE – VERN (RATE MIN tb-ON)
- BRAKES – OFF (tb-OFF)
- MODE – ORB LD, ENTER

THC MnvR MRM1 -Z (THC up) to MRM1 LOW HOVER posn:

X	Y	Z	PITCH	YAW	ROLL	PL ID
-1116	0	-454	0	0	0	3
SY	SP	EP	WP	WY	WR	
-16.3	+35.2	-48.7	-39.4	+25.2	+20.6	

- A6U √PL RETEN LAT RDY 1,2,3,4,5 tb (five) – bp

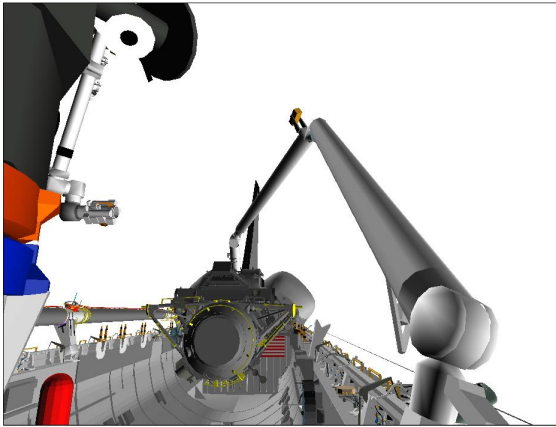

CCTV A (0,15)

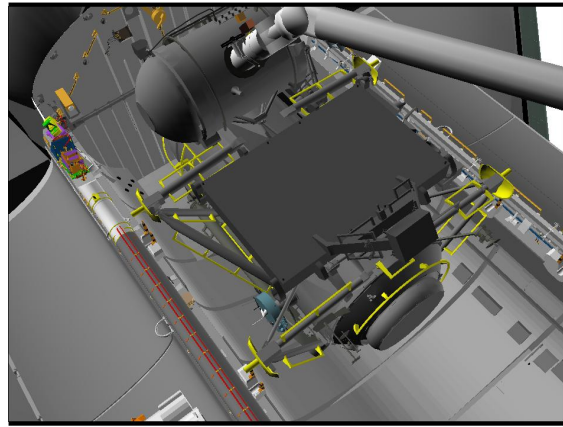

SSRMS TIP ELBOW (20,30)

9. MNVR TO MRM1 HANDOFF POSN

V10/L	Elbow
V10/R	SSRMS Tip Elbow
MON 1	C
MON 2	A

NOTE

Minimum clearance between MRM1 fwd stbd trunnion and SSRMS TIP LEE during mnvr to MRM1 HANDOFF posn is expected to be 26 inches. Monitor with SSRMS Tip Elbow Camera and Camera C

THC

Mnvr MRM1 -Z (THC up) and +X (THC pull) to MRM1 HANDOFF posn:

X	Y	Z	PITCH	YAW	ROLL	PL ID
-1045	0	-600	0	0	0	3
SY	SP	EP	WP	WY	WR	
-25.0	+53.4	-50.3	-59.7	+30.2	+28.6	

BRAKES – ON (tb-ON)

- * If Orbiter Attitude Control: ROBOTICS ATTITUDE MAINTENANCE *
- * (ORB OPS, REBOOST/DAP) steps 1,2 *

Notify SSRMS Operator SRMS at MRM1 HANDOFF posn with Brakes On, GO for MRM1 Grapple

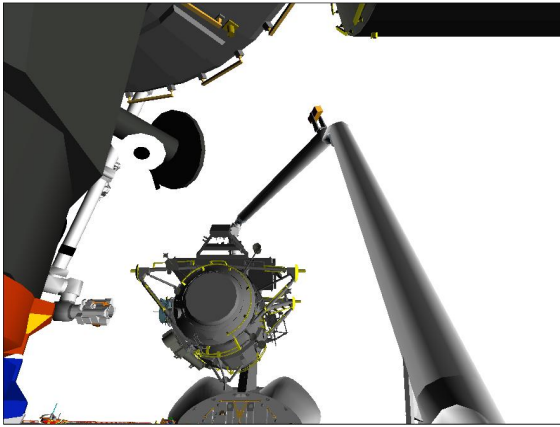

CCTV A (0,30)

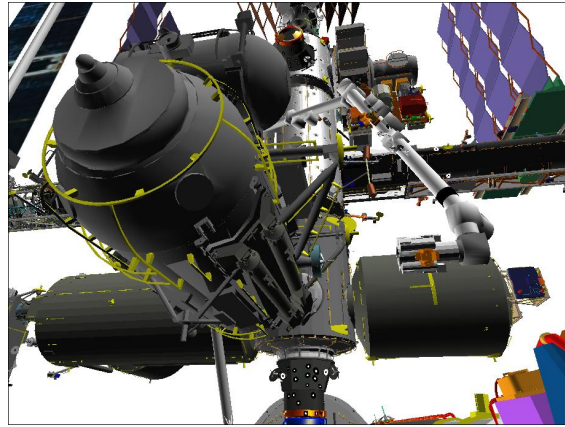

CCTV C (-10,30)

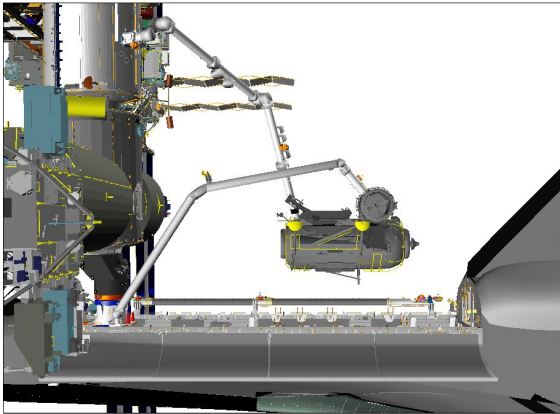

PORT

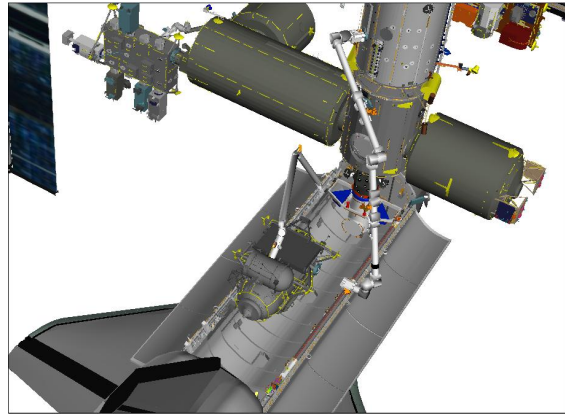

BIRD'S EYE

MRM1 RELEASE

1. MRM1 RELEASE

On SSRMS Operator GO for MRM1 Release,

V10/L	B
V10/R	SSRMS Tip Elbow
MON 1	EE
MON 2	A

CCTV – config for ungrapple

- RMS WRIST, ZOOM: 34.0 HFOV
- FOCUS: 5 ft

NOTE

CONTR ERR It and 'S96 PDRS CNTL' msg may occur due to Consistency/Envelope Check error

RHC RATE – COARSE (RATE MIN tb-OFF)

SM 94 PDRS CONTROL

AUTO BRAKE INH – ITEM 10 EXEC (*)

A8U BRAKES – OFF (tb-OFF)
MODE – TEST, ENTER
Wait 5 sec

BRAKES – ON (tb-ON)

SM 94 PDRS CONTROL

AUTO BRAKE ENA – ITEM 9 EXEC (*)
PL ID – ITEM 3 +0 EXEC
INIT ID – ITEM 24 +0 EXEC

RATE – VERN (RATE MIN tb-ON)
BRAKES – OFF (tb-OFF)
MODE – END EFF, ENTER

CAUTION

Monitor EE tb timing to prevent EE motor burnout

SM 169 PDRS STATUS

EE MODE – AUTO
RELEASE sw – depress (mom)

When OPEN tb – gray, mnvr arm clear of grapple pin

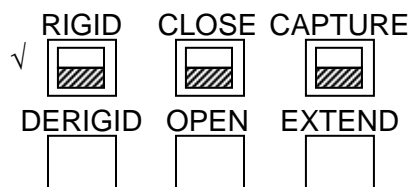

CRITICAL TIMES (28 sec total):

DERIGID tb – gray, 5 sec max, then
OPEN tb – gray, 3 sec max, then
EXTEND tb – gray, 20 sec max

EE MODE – OFF

- * If manual release reqd: *
- * EE MODE – MAN *
- * MAN CONTR – DERIGID (hold until DERIGID tb-gray, *
- * 5 sec max) *
- * RELEASE sw – depress (hold until OPEN tb-gray, *
- * 3 sec max) *
- * Mnvr arm clear, then *
- * EE MAN CONTR – DERIGID (hold until EXTEND tb-gray, *
- * 20 sec max) *
- * MODE – OFF *

NOTE

Minimum clearance to JEM is 44 inches at BACKOFF posn.
Monitor with Camera A

THC

Mnvr to MRM1 BACKOFF posn:

X	Y	Z	PITCH	YAW	ROLL	PL ID
-1077	0	-702	310	0	0	0
SY	SP	EP	WP	WY	WR	
-29.2	+59.9	-51.2	-67.6	+32.4	+32.2	

A6U

√DAP: FREE

GNC 20 DAP CONFIG

Permanently edit CA for DAPs A11, A12, B12, and B13

See DOCKED DAP REFERENCE (ORB OPS, REBOOST/DAP) for CA

2. MNVR TO MRM1 CLEARANCE POSN

V10/L	B
V10/R	SSRMS Tip Elbow
MON 1	D
MON 2	A

NOTE

Minimum clearance between EE and MRM1 during Single
Joint SY mnvr to MRM1 CLEARANCE posn is 31 inches.
Monitor with Camera D

RHC

RATE – as reqd (VERN within 10 ft)

MODE – SINGLE, ENTER

Mnvr to MRM1 CLEARANCE posn:

Backoff	SY	SP	EP	WP	WY	WR	
	-29.2	+59.9	-51.2	-67.6	+32.4	+32.2	
1: SY +	+20.0						
MRM1	+20.0	+59.9	-51.2	-67.6	+32.4	+32.2	
Clearance	X	Y	Z	PITCH	YAW	ROLL	PL ID
	-1081	-345	-580	284	22	42	0

BRAKES – ON (tb-ON)

PARAM – PORT TEMP

JOINT – CRIT TEMP

Notify SSRMS Operator SRMS at MRM1 CLEARANCE posn with Brakes On,
GO for maneuver to MRM1 PRE-DOCK posn

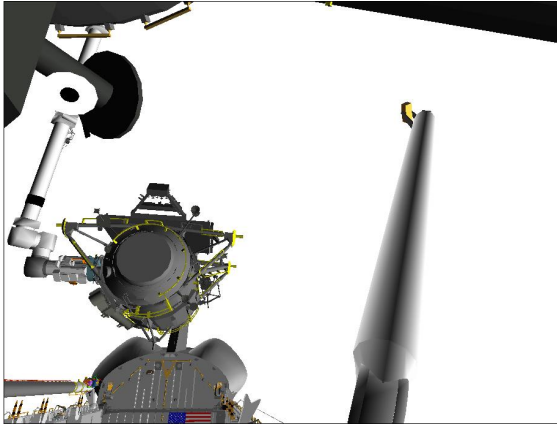

CCTV A (10,25)

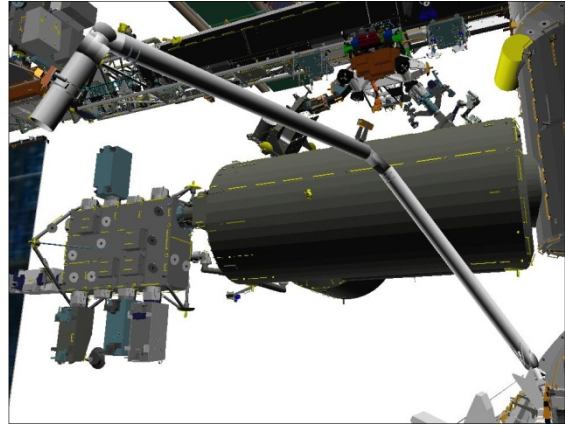

CCTV B (-25,15)

MRM1 DOCK VIEWING

1. SETUP

SM 94 PDRS CONTROL

√ PL ID, ITEM 3: 0

√ INIT ID, ITEM 24: 0

V10/L	B
V10/R	C
MON 1	Elbow → EE
MON 2	A

SM 94 PDRS CONTROL

END POS – ITEM 18 -8 7 0 -4 6 5 -7 7 7 EXEC

ATT – ITEM 21 +1 0 7 +3 2 9 +2 7 9 EXEC

CMD CK – ITEM 25 EXEC (GOOD)

2. MNVR TO MRM1 INTERMEDIATE DOCK VIEWING POSN

On SSRMS GO for MNVR TO MRM1 DOCK VIEWING posn,

RHC RATE – as reqd (VERN within 10 ft)
 BRAKES – OFF (tb-OFF)
 MODE – SINGLE, ENTER

Mnvr to MRM1 INTERMEDIATE DOCK VIEWING posn:

MRM1
 Clearance
 1: WP +
 Intermediate
 Dock View

SY	SP	EP	WP	WY	WR	
+20.0	+59.9	-51.2	-67.6	+32.4	+32.2	
			+100.0			
+20.0	+59.9	-51.2	+100.0	+32.4	+32.2	
X	Y	Z	PITCH	YAW	ROLL	PL ID
-1030	-367	-697	125	41	340	0

3. MNVR TO MRM1 DOCK VIEWING POSN

NOTE

Minimum clearance to JEM during OCAS mnvr to MRM1 DOCK VIEWING posn is 39 inches. Monitor with Camera A

RHC RATE – VERN (RATE MIN tb-ON)
 MODE – OPR CMD, ENTER (READY lt on)

AUTO SEQ – PROCEED (IN PROG lt on)

When AUTO SEQ IN PROG lt – off:

BRAKES – ON (tb-ON)

MRM1 DOCK VIEWING posn:

(00:45)

X	Y	Z	PITCH	YAW	ROLL	PL ID
√ -870	-465	-777	107	329	279	0
SY	SP	EP	WP	WY	WR	
√ +52.6	+58.4	-20.3	+103.3	-15.0	-3.4	

PARAM – PORT TEMP
JOINT – CRIT TEMP

Notify SSRMS Operator SRMS at MRM1 DOCK VIEWING posn with Brakes On,
GO for MRM1 DOCK

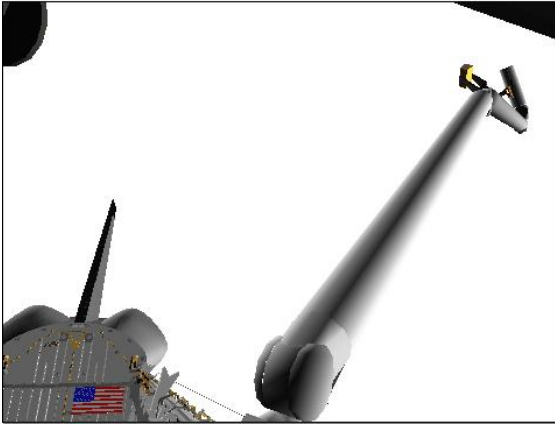

CCTV A (20,20)

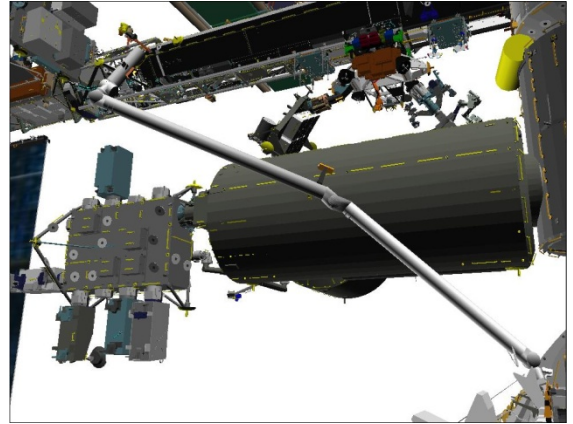

CCTV B (-25,15)

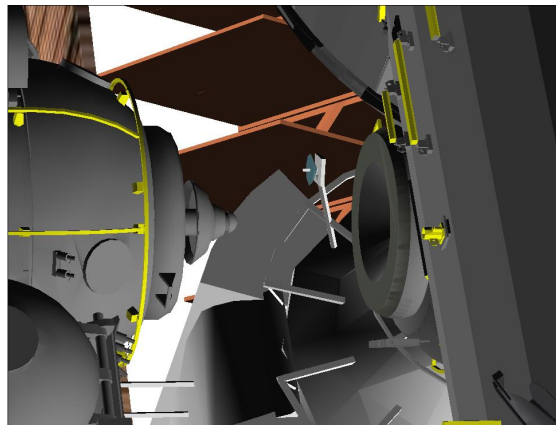

EE (HFOV: 10)

This Page Intentionally Blank

OBSS NOMINAL

MNVR TO OBSS HANDOFF PRE-GRAPPLE	FS 2-2
OBSS GRAPPLE FROM SSRMS.....	FS 2-5
MNVR TO OBSS UNDOCK.....	FS 2-7
OBSS MNVR TO FLAT FIELD	FS 2-9

**OBSS
NOMINAL**

MANEUVER TO OBSS HANDOFF PRE-GRAPPLE

1. SETUP

NOTE

Assumed starting position is MRM1 DOCK VIEWING

Verify SSRMS at MRM1 BACKOFF posn:

SR	SY	SP	EP	WP	WY	WR
+7.2	+108.8	-17.3	-89.9	-156.0	-177.8	-101.2

V10/L	A
V10/R	P1 LOOB
MON 1	C
MON 2	Elbow

2. MNVR TO OBSS HANDOFF PRE-GRAPPLE

NOTE

Clearance between SRMS Upper Boom and JEM starts at 44 inches, increases in line 2, and then decreases to 45 inches in line 3. Monitor with Camera A

RHC

RATE – as reqd (VERN within 10 ft)

BRAKES – OFF (tb-OFF)

MODE – SINGLE, ENTER

Mnvr to OBSS HANDOFF PRE-GRAPPLE posn:

Dock View	SY	SP	EP	WP	WY	WR	
1: EP –	+52.6	+58.4	-20.3	+103.3	-15.0	-3.4	
2: SY –	+24.0		-34.4				
3: SP +		+64.8					
4: WY +					+11.3		
5: WP –				-99.4			
6: WR –						-99.0	
Pre-grapple	+24.0	+64.8	-34.4	-99.4	+11.3	-99.0	
	X	Y	Z	PITCH	YAW	ROLL	PL ID
	-1018	-362	-676	284	0	270	0

BRAKES – ON (tb-ON)

Notify SSRMS Operator SRMS at OBSS Handoff Pre-grapple posn with Brakes On, GO for OBSS Unberth

OBSS
NOMINAL

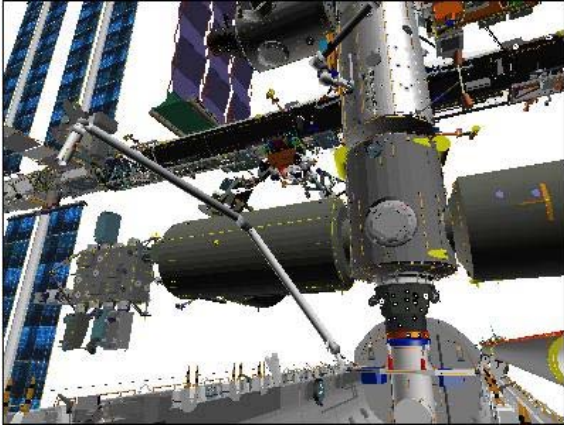

CCTV C (-25,20)



CCTV A (0,30)

3. CONFIGURE POWER

CAUTION
SPEE power must be applied within 90 min
to prevent sensor package damage

On SSRMS Operator GO to release stbd MRLs,
STBD RMS HTR A,B (two) – OFF

- A6U EVENT TIMER MODE – UP
 CNTL – START
- MA73C:C cb MCA PWR AC3 3Φ MID 2 – op
 √AC2 3Φ MID 2 – op
- MA73C:D √AC3 3Φ MID 4 – op
- R13L PL BAY MECH PWR SYS (two) – ON

4. STBD MRL RELEASE

SM 94 PDRS CONTROL
RMS STBD – ITEM 2 EXEC (*)
√STBD AFT, MID, FWD REL (six) = 0

NOTE
Expect single motor drive time for MRL release

STBD RMS RETEN LAT – REL (tb-REL) (18 sec max)
– OFF

If motor drive time > 18 sec, √MCC

SM 94 PDRS CONTROL
√STBD AFT, MID, FWD REL (six) = 1

5. RECONFIGURE POWER
R13L PL BAY MECH PWR SYS (two) – OFF
MA73C:C cb MCA PWR AC3 3Φ MID 2 – cl
√AC2 3Φ MID 2 – op
MA73C:D √AC3 3Φ MID 4 – op

Give SSRMS Operator GO for OBSS Unberth and mnvr to Handoff

Monitor RFL Status

After OBSS Unberth,

SM 94 PDRS CONTROL

RMS PORT – ITEM 1 EXEC (*)

OBSS GRAPPLE FROM SSRMS

1. SETUP FOR GRAPPLE

R12

√Green Jumper – ISS

V10/L	A
V10/R	P1 LOOB
MON 1	C
MON 2	EE

A7U

CCTV – configure for grapple
 – RMS WRIST, ZOOM: 34.0 HFOV
 FOCUS: 5 ft
 Maintain eyepoint approx 18 in when using grapple overlay

R12(OBSS) √SPEE PWR – OFF

L12(SSP 1) √APCU 2 OUTPUT RLY – OP (tb-bp)

2. OBSS GRAPPLE AT HANDOFF POSN

On SSRMS Operator GO for SRMS OBSS Grapple,

RHC

RATE – VERN (RATE MIN tb-ON)
 BRAKES – OFF (tb-OFF)
 MODE – END EFF, ENTER

Mnvr to grapple envelope

CAUTION
 Monitor EE tb timing to prevent EE motor burnout

EE MODE – AUTO
 CAPTURE sw – depress (mom)

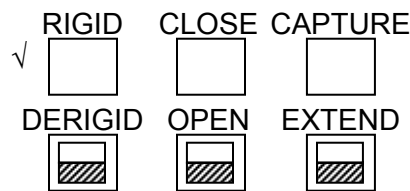

CRITICAL TIMES (28 sec total):
 CAPTURE tb – gray, then
 CLOSE tb – gray, 3 sec max, then
 RIGID tb – gray, 25 sec max

EE MODE – OFF

- * If manual capture required: *
- * EE MODE – MAN *
- * CAPTURE sw – depress (hold until CLOSE tb-gray, 3 sec max) *
- * MAN CONTR – RIGID (hold until RIGID tb-gray, 25 sec max) *
- * MODE – OFF *

MODE – TEST, ENTER
 Wait 5 sec

BRAKES – ON (tb-ON)

SM 94 PDRS CONTROL
 PL ID – ITEM 3 +2 EXEC
 INIT ID – ITEM 24 +2 EXEC

Expected OBSS HANDOFF posn:

X	Y	Z	PITCH	YAW	ROLL	PL ID
						2
√ -1029	+229	-614	14	270	0	2
SY	SP	EP	WP	WY	WR	
√ +25.8	+66.3	-49.0	-85.9	+10.7	-100.7	

*Display singularity

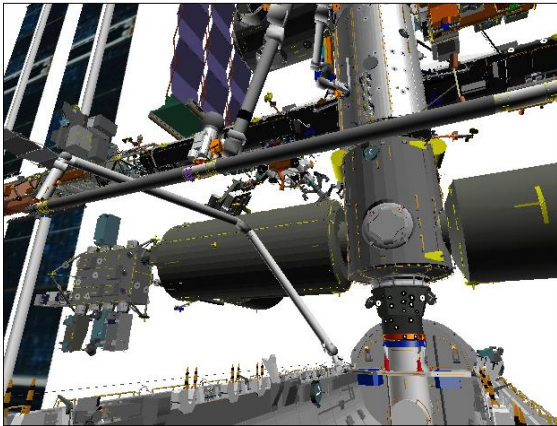

CCTV C (-25,20)



CCTV A (0,30)

R12 Green Jumper – LDRI/ITVC

Perform ACTIVATION (LDRI/ITVC Cue Card, PHOTO/TV)

Perform LCH ACTIVATION (LCS Cue Card, PHOTO/TV)

Give SSRMS Operator GO for OBSS ungrapple

Perform LCC ACTIVATION (LCS Cue Card, PHOTO/TV)

Perform LCC DEACTIVATION (LCS Cue Card, PHOTO/TV), steps 1 and 2

R12 Green Jumper – ISS

Review GENERIC END EFFECTOR CUE CARD – ISS/SHUTTLE DOCKED OPS

MNVR TO OBSS UNDOCK

1. SETUP

NOTE

Assumed starting position is BATTERY R&R VIEWING

Verify SSRMS at DOCKING posn:

SR	SY	SP	EP	WP	WY	WR
+230.0	+150.0	-190.0	+130.0	0.0	-150.0	0.0

V10/L	Elbow (B)
V10/R	P1 LOOB
MON 1	A
MON 2	C

SM 94 PDRS CONTROL

√PL ID, ITEM 3: 2

√INIT ID, ITEM 24: 2

END POS – ITEM 18 -1 0 3 6 +2 4 3 -5 6 3 EXEC

ATT – ITEM 21 +1 1 9 +2 8 0 +1 2 1 EXEC

CMD CK – ITEM 25 EXEC (GOOD)

2. MNVR TO OBSS UNDOCK

On SSRMS Operator GO for SRMS maneuver to OBSS Undock,

RHC RATE – as reqd (VERN within 10 ft)
 BRAKES – OFF (tb-OFF)
 MODE – SINGLE, ENTER

Mnvr to ICC UNBERTH VIEWING posn:

	SY	SP	EP	WP	WY	WR	
Battery View	+30.0	+20.0	-25.0	+5.0	-10.0	+100.0	
1: WY +					0.0		
2: WR –						0.0	
3: SY –	+20.0						
ICC View	+20.0	+20.0	-25.0	+5.0	0.0	0.0	
	X	Y	Z	PITCH	YAW	ROLL	PL ID
	-1305	-327	-1023	83	1	341	2

NOTE

Minimum clearance between SRMS Upper Boom and JEM is 23 inches during OCAS. Monitor with Camera A

RHC RATE – COARSE (RATE MIN tb-OFF)
 MODE – OPR CMD, ENTER (READY lt on)

 After PROCEED, if motion no longer apparent but POR is within
 1 in/1 deg and IN PROG lt – on:
 AUTO SEQ – STOP

AUTO SEQ – PROCEED (IN PROG lt on)

When AUTO SEQ IN PROG It – off:

HANDOFF LOW posn: (05:00)

	X	Y	Z	PITCH	YAW	ROLL	PL ID
√	-1036	+243	-563	119	280	121	2
	SY	SP	EP	WP	WY	WR	
√	+25.8	+47.0	-49.0	-85.9	+10.7	-100.7	

RHC

RATE – VERN (RATE MIN tb-ON)
MODE – SINGLE, ENTER

Mnvr to OBSS UNDOCK posn:

	SY	SP	EP	WP	WY	WR	
Handoff Low	+25.8	+47.0	-49.0	-85.9	+10.7	-100.7	
1: SP +		+66.3					
Undock	+25.8	+66.3	-49.0	-85.9	+10.7	-100.7	
	X	Y	Z	PITCH	YAW	ROLL	PL ID
	-1029	+229	-614	14	270	0	2

*Display singularity

BRAKES – ON (tb-ON)
√MODE – not DIRECT (It off)

PARAM – PORT TEMP
JOINT – CRIT TEMP

Notify SSRMS Operator that SRMS at OBSS Undock posn

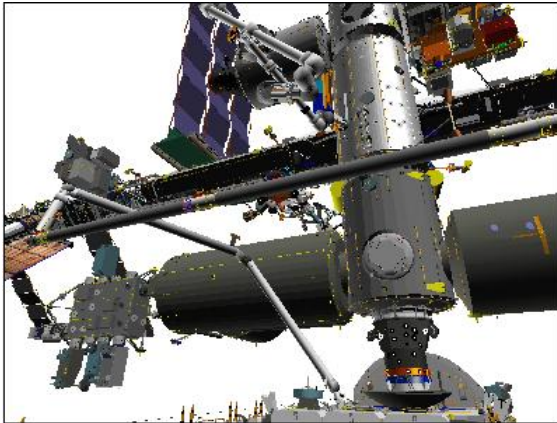

CCTV C (-25,25)



CCTV A (0,30)

OBSS MNVR TO FLAT FIELD

WARNING For UNDOCKED ops only

1. SETUP

V10/L	Elbow
V10/R	D (C)
MON 1	A
MON 2	B

SM 94 PDRS CONTROL

- √ PL ID, ITEM 3: 2
- √ INIT ID, ITEM 24: 2
- AUTO MODES – ITEM 13 +Z EXEC

Verify at OBSS UNDOCK posn:

	X	Y	Z	PITCH	YAW	ROLL	PL ID	
√	-1029	+229	-614	14	270	0	2	*
	SY	SP	EP	WP	WY	WR		
√	+25.8	+66.3	-49.0	-85.9	+10.7	-100.7		

*Display singularity

RHC

2. ACAS TO STBD SURVEY START

- RATE – COARSE (RATE MIN tb-OFF)
- BRAKES – OFF (tb-OFF)
- MODE – AUTO 1, ENTER

- * If unable to enter AUTO mode (no AUTO READY It): *
- * END POS – ITEM 18 -1 0 2 9 +2 2 9 -6 1 4 EXEC *
- * ATT – ITEM 21 +1 4 +2 7 0 +0 EXEC *
- * CMD CK – ITEM 25 EXEC (GOOD) *
- * *
- * MODE – OPR CMD, ENTER (READY It on) *
- * AUTO SEQ – PROCEED (IN PROG It on) *
- * *
- * When AUTO SEQ IN PROG It – off: *
- * MODE – AUTO 1, ENTER *

- √ START PT, ITEM 17: 148

SM 169 PDRS STATUS

Monitor ACAS progress

AUTO SEQ – PROCEED (IN PROG It on)

Pt	X	Y	Z	Pitch	Yaw	Roll	•
148P	-1029	+229	-614	14	270	0	
149	-800	+500	-250	281	333	95	
150	-1130	+350	-400	325	336	30	
151P	-1270	+350	-445	0	0	11	

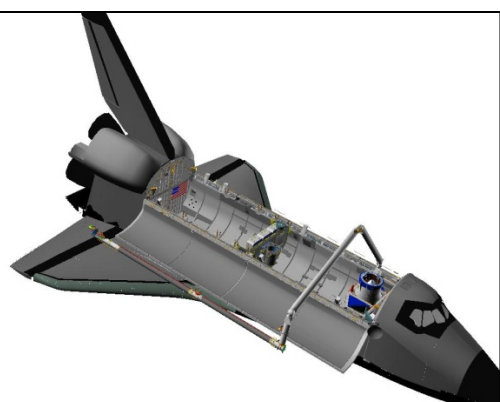
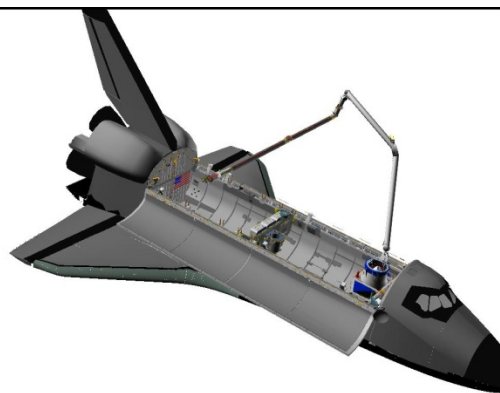

When AUTO SEQ IN PROG It – off:
BRAKES – ON (tb-ON)

Verify at FLAT FIELD posn:

	X	Y	Z	PITCH	YAW	ROLL	PL ID
√	-1270	+350	-445	0	0	11	2
	SY	SP	EP	WP	WY	WR	
√	-90.1	+25.0	-65.8	-57.6	0.0	-249.9	

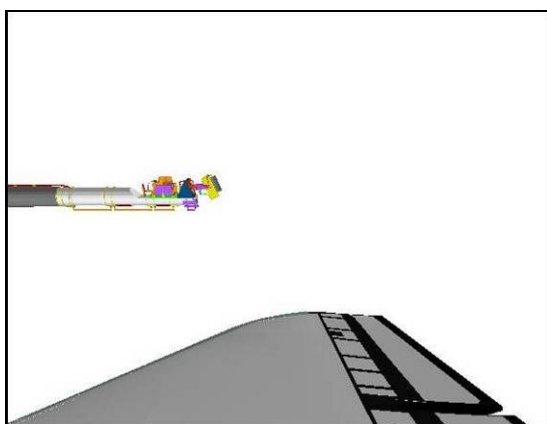

CCTV C (95,-5)

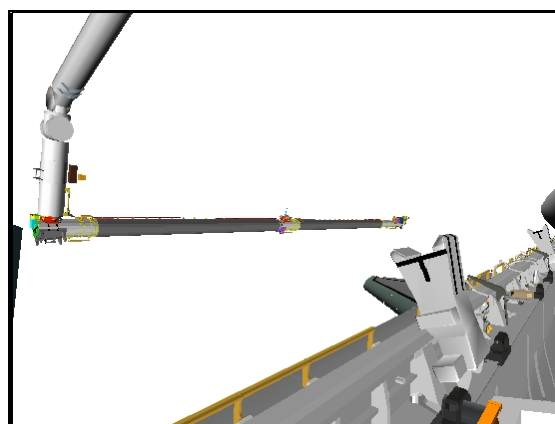

CCTV D (-40,0)

3. SETUP FOR STBD SURVEY

SM 94 PDRS CONTROL

AUTO MODES – ITEM 13 +1 +2 +3 +4 EXEC

For survey scan pattern, refer to OBSS SCAN PATTERN CUE CARDS – STBD & PORT, AND WING GLOVE & CREW CABIN

Perform ACTIVATION (LDRI/ITVC Cue Card, PHOTO/TV) steps 1, 3, 4, and 5

L12(SSP 1) APCU 2 CONV – OFF (tb-bp) |
Wait 10 sec
APCU 2 CONV – ON (tb-gray) |

Perform LCC ACTIVATION (LCS, Cue Card, PHOTO/TV)

Perform IDC SOFTWARE ACTIVATION (IDC, Cue Card, PHOTO/TV) steps 1 and 2

A7U MUX 1 L ← MIDDECK
LDRI MODE 6 pb – push (brighter flickering LDRI video)
DTV ← PL2

CAMR CMD PAN/TILT – HI RATE

PAN – L (to hard stop)

TILT – UP (to hard stop)

PAN/TILT – RESET, HI RATE (LO within 10°)

PAN: +103 (right)

TILT: -260 (down)

VID OUT – as desired (not DTV)

√VID IN – not PL2

L10(VTR) REC pb – push, hold
PLAY pb – push, simo (red ●)

BRAKES – OFF (tb-OFF) |

Go to OBSS LDRI/IDC RCC SURVEY – STBD (OBSS OPERATIONS), step 5.
Reference procedure notes prior to beginning surveys

This Page Intentionally Blank

VIEWING SUPPORT

ICC UNBERTH VIEWING.....	FS 3-2
SGANT & EOTP VIEWING.....	FS 3-4
BATTERY R&R VIEWING	FS 3-6

**VIEWING
SUPPORT**

ICC UNBERTH VIEWING

1. SETUP

NOTE

Assumed starting position is Pre-cradle

Verify SSRMS at DOCKING posn:

SR	SY	SP	EP	WP	WY	WR
+230.0	+150.0	-190.0	+130.0	0.0	-150.0	0.0

V10/L	A
V10/R	P1 LOOB
MON 1	B
MON 2	Elbow

SM 94 PDRS CONTROL

√PL ID, ITEM 3: 0

√INIT ID, ITEM 24: 0

END POS – ITEM 18 -1 2 3 3 -3 1 9 -4 3 6 EXEC

ATT – ITEM 21 +3 5 3 +1 9 +1 EXEC

CMD CK – ITEM 25 EXEC (GOOD)

2. MNVR TO ICC UNBERTH VIEWING

Notify SSRMS Operator SRMS maneuver to ICC Unberth Viewing in work

NOTE

Monitor clearance between SRMS Tip and Port PLBD with Camera B

RHC

RATE – VERN (RATE MIN tb-ON)

BRAKES – OFF (tb-OFF)

MODE – OPR CMD, ENTER (READY lt on)

After PROCEED, if motion no longer apparent but POR is within
1 in/1 deg and IN PROG lt – on:
AUTO SEQ – STOP

AUTO SEQ – PROCEED (IN PROG lt on)

When AUTO SEQ IN PROG lt – off:

BRAKES – ON (tb-ON)

ICC UNBERTH VIEWING posn:

(00:45)

X	Y	Z	PITCH	YAW	ROLL	PL ID
-1233	-319	-436	353	19	1	0
SY	SP	EP	WP	WY	WR	
+20.0	+20.0	-25.0	+5.0	0.0	0.0	

√MODE – not DIRECT (lt off)

PARAM – PORT TEMP

JOINT – CRIT TEMP

Notify SSRMS Operator SRMS at ICC Unberth Viewing posn with Brakes On

3. CONFIGURE CAMERA FOR VIEWING

Configure camera as shown for ICC unberth viewing support

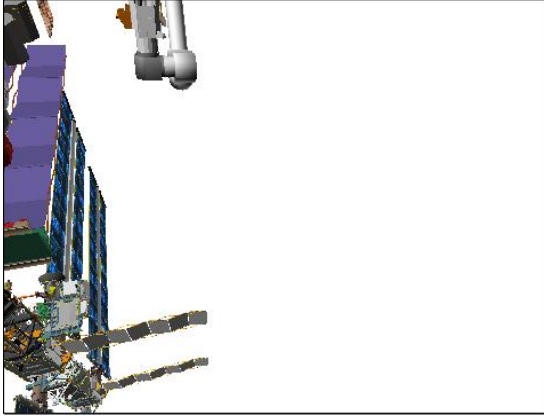

ELBOW (-100,60)

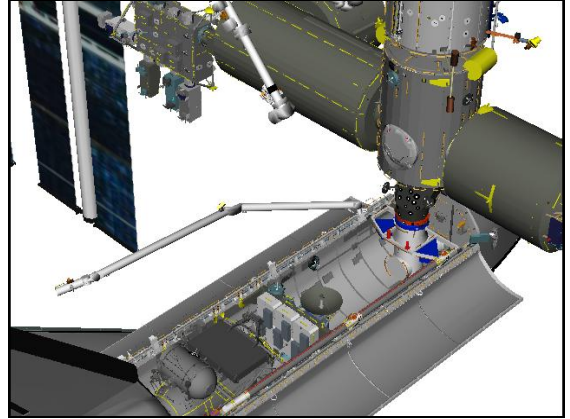

BIRD'S EYE

SGANT & EOTP VIEWING

1. SETUP

NOTE

Assumed starting position is ICC UNBERTH VIEWING

Verify SSRMS at LAB RELEASE posn:

SR	SY	SP	EP	WP	WY	WR
+2.6	+133.8	-95.5	+83.8	-107.9	-159.2	+114.4

V10/L	B
V10/R	P1 LOOB
MON 1	A
MON 2	Elbow → EE

SM 94 PDRS CONTROL

√PL ID, ITEM 3: 0

√INIT ID, ITEM 24: 0

END POS – ITEM 18 -8 2 0 -4 9 3 -7 6 4 EXEC

ATT – ITEM 21 +1 5 9 +7 +0 EXEC

CMD CK – ITEM 25 EXEC (GOOD)

2. MNVR TO SGANT & EOTP VIEWING

Notify SSRMS Operator SRMS maneuver to SGANT & EOTP Viewing in work

NOTE

Minimum clearance between SRMS Upper Boom and JEM is 22 inches during OCAS and increases to 33 inches at SGANT & EOTP Viewing. Monitor with Camera A

RHC

RATE – VERN (RATE MIN tb-ON)

BRAKES – OFF (tb-OFF)

MODE – OPR CMD, ENTER (READY It on)

After PROCEED, if motion no longer apparent but POR is within 1 in/1 deg and IN PROG It – on:
 AUTO SEQ – STOP

AUTO SEQ – PROCEED (IN PROG It on)

When AUTO SEQ IN PROG It – off:

BRAKES – ON (tb-ON)

SGANT & EOTP VIEWING posn:

(01:30)

X	Y	Z	PITCH	YAW	ROLL	PL ID
-820	-493	-764	159	7	0	0
SY	SP	EP	WP	WY	WR	
+53.0	+62.0	-23.0	+107.0	+48.0	+64.0	

BRAKES – ON (tb-ON)

√MODE – not DIRECT (It off)

PARAM – PORT TEMP
JOINT – CRIT TEMP

Notify SSRMS Operator SRMS at SGANT & EOTP Viewing posn with Brakes On |

3. CONFIGURE CAMERAS FOR VIEWING
Configure cameras as shown for SGANT & EOTP viewing support

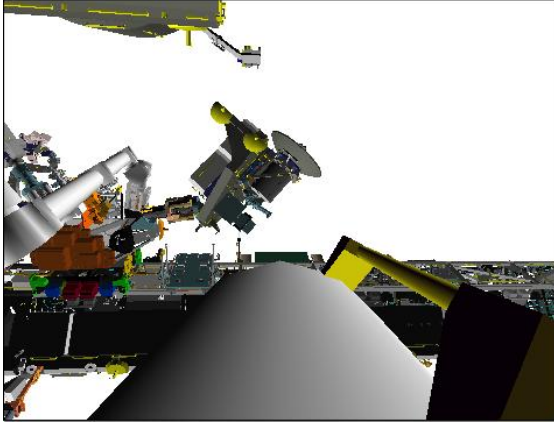

EE



CCTV B (-20,30)

BATTERY R&R VIEWING

1. SETUP

NOTE

Assumed starting position is OBSS HANDOFF

Verify SSRMS at MBS PDGF3 PRE-GRAPPLE posn:

SR	SY	SP	EP	WP	WY	WR
+116.8	+161.2	-117.3	+81.1	-79.9	-134.8	+6.6

V10/L	C (Elbow)
V10/R	P1 LOOB
MON 1	A
MON 2	B

SM 94 PDRS CONTROL

√PL ID, ITEM 3: 2

√INIT ID, ITEM 24: 2

END POS – ITEM 18 -1 3 0 5 -3 2 7 -1 0 2 3 EXEC

ATT – ITEM 21 +8 3 +0 +3 4 1 EXEC

CMD CK – ITEM 25 EXEC (GOOD)

2. MNVR TO BATTERY R&R VIEWING

Notify SSRMS Operator SRMS maneuver to Battery R&R Viewing in work

RHC RATE – VERN (RATE MIN tb-ON)
BRAKES – OFF (tb-OFF)
MODE – SINGLE, ENTER

Mnvr to HANDOFF LOW posn:

OBSS
Handoff
1: SP –
Handoff Low

SY	SP	EP	WP	WY	WR	
+25.8	+66.3	-49.0	-85.9	+10.7	-100.7	
	+47.0					
+25.8	+47.0	-49.0	-85.9	+10.7	-100.7	
X	Y	Z	PITCH	YAW	ROLL	PL ID
-1036	+243	-563	119	280	121	2

NOTE

Minimum clearance between SRMS Upper Boom and JEM is 23 inches during OCAS. Monitor with Camera A

RHC RATE – COARSE (RATE MIN tb-OFF)
MODE – OPR CMD, ENTER (READY It on)

After PROCEED, if motion no longer apparent but POR is within 1 in/1 deg and IN PROG It – on:
AUTO SEQ – STOP

AUTO SEQ – PROCEED (IN PROG It on)

When AUTO SEQ IN PROG It – off:

ICC UNBERTH VIEWING posn: (05:00)

X	Y	Z	PITCH	YAW	ROLL	PL ID
-1305	-327	-1023	83	0	341	2
SY	SP	EP	WP	WY	WR	
+20.0	+20.0	-25.0	+5.0	0.0	0.0	

RHC

RATE – as reqd (VERN within 10 ft)
MODE – SINGLE, ENTER

Mnvr to BATTERY R&R VIEWING posn:

ICC View
1: SY +
2: WR +
3: WY –
Battery View

SY	SP	EP	WP	WY	WR		
+20.0	+20.0	-25.0	+5.0	0.0	0.0		
+30.0							
					+100.0		
				-10.0			
+30.0	+20.0	-25.0	+5.0	-10.0	+100.0		
X	Y	Z	PITCH	YAW	ROLL	PL ID	
-998	-949	-321	203	68	242	2	

BRAKES – ON (tb-ON)

√MODE – not DIRECT (It off)

PARAM – PORT TEMP

JOINT – CRIT TEMP

Notify SSRMS Operator SRMS at BATTERY R&R VIEWING posn with Brakes On

3. CONFIGURE CAMERA FOR VIEWING

Configure camera as shown for Battery R&R viewing support

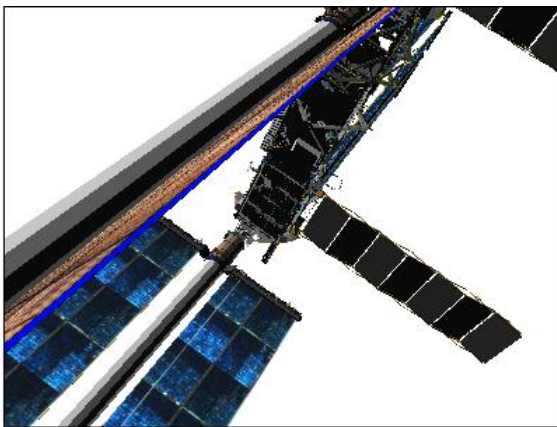

ITVC (145,-130)

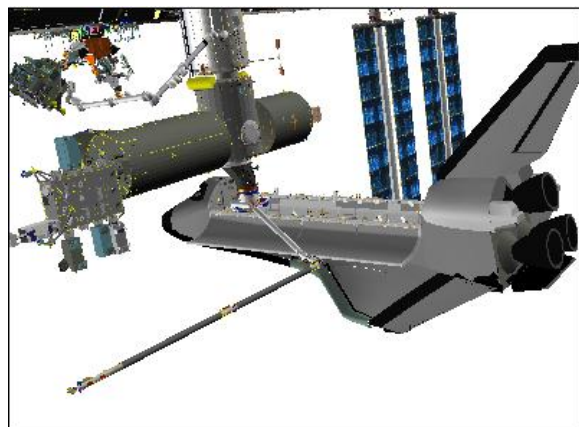

BIRD'S EYE

This Page Intentionally Blank

MRM1 OFF-NOMINAL

SJ MRM1 PRE-GRAPPLE.....	FS 4-2
GRAPPLE	FS 4-6
UNBERTH.....	FS 4-10
RELEASE.....	FS 4-17
MRM1 CONTINGENCY REBERTH.....	FS 4-22
PROBE REMOVAL	FS 4-31

**MRM1
OFF-NOMINAL**

SJ MRM1 PRE-GRAPPLE

1. SETUP

SM 94 PDRS CONTROL

√ PL ID, ITEM 3: 0

√ INIT ID, ITEM 24: 0

Verify SRMS at SGANT & EOTP VIEWING posn:

X	Y	Z	PITCH	YAW	ROLL	PL ID
-820	-493	-764	159	7	0	0
SY	SP	EP	WP	WY	WR	
+53.0	+62.0	-23.0	+107.0	+48.0	+64.0	

R12

√ Green Jumper – ISS

V10/L	C
V10/R	P1 LOOB (Elbow)
MON 1	B
MON 2	A

A7U

CCTV – perform PAN/TILT RESET on PLB cameras
– fully zoom out PLB & Elbow cameras for SJ pictures

2. MNVR TO MRM1 PRE-GRAPPLE POSN

On SSRMS Operator GO for MNVR TO MRM1 PRE-GRAPPLE posn,
PARAM – JOINT ANGLE

If SINGLE MODE available:

RHC

RATE – as reqd (VERN within 10 ft)

BRAKES – OFF (tb-OFF)

MODE – best available

Mnvr to MRM1 PRE-GRAPPLE posn:

SGANT &
EOTP View

1: SP –
2: SY –
3: EP –
4: WP –
5: WY –
6: WR –
MRM Pre-Gpl

SY	SP	EP	WP	WY	WR	
+53.0	+62.0	-23.0	+107.0	+48.0	+64.0	
	+47.6					
-18.5						
		-66.9				
			-34.4			
				+26.6		
					+22.1	
-18.5	+47.6	-66.9	-34.4	+26.6	+22.1	
X	Y	Z	PITCH	YAW	ROLL	PL ID
-1141	0	-525	310	0	0	0

If SINGLE MODE:

BRAKES – ON (tb-ON)

MODE – not DIRECT (It off)

PARAM – PORT TEMP

JOINT – CRIT TEMP

Notify SSRMS Operator SRMS at MRM1 PRE-GRAPPLE posn

MRM1
OFF-NOMINAL

Step 1:

Drive SP- (for 14.4°)
From +62.0° to +47.6°

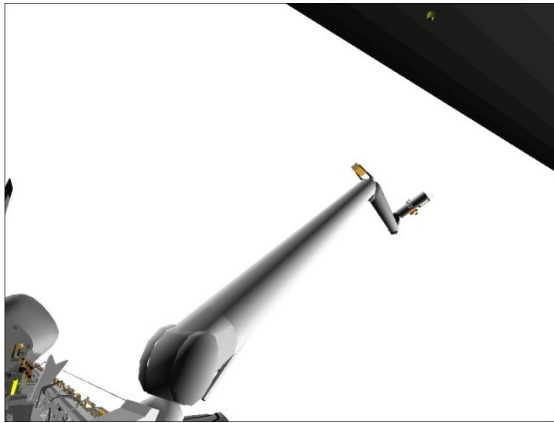

CCTV A (35,20)

Step 2:

Drive SY- (for 71.5°)
From +53.0° to -18.5°

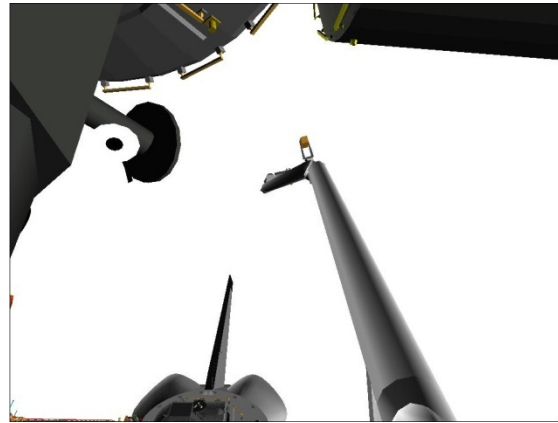

CCTV A (5,30)

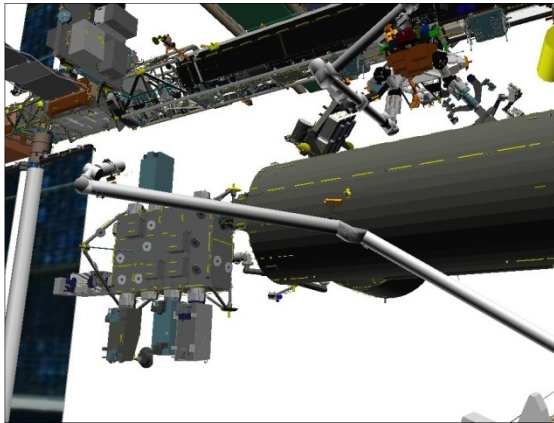

CCTV B (-30,15)

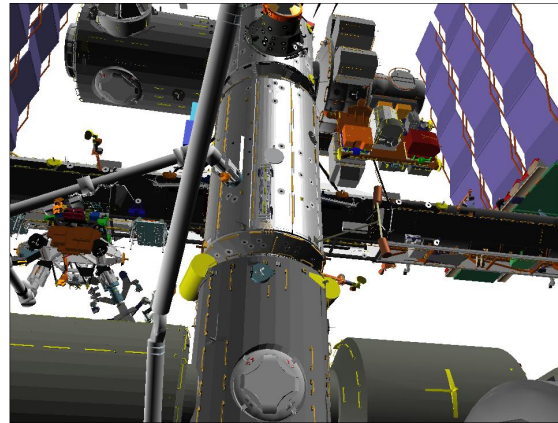

CCTV B (10,35)

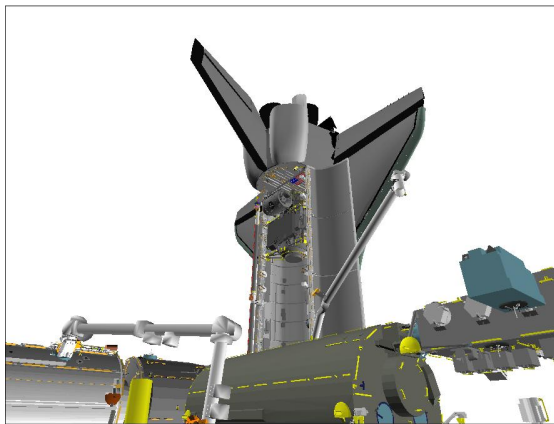

P1 LOOB (130,30)

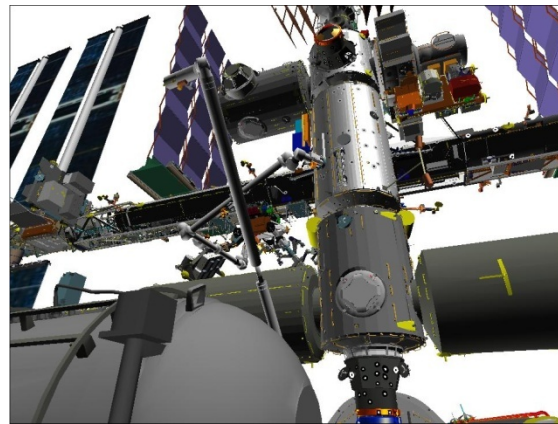

CCTV C (-20,30)

Step 3:

Drive EP- (for 43.9°)
From -23.0° to -66.9°



CCTV A (5,30)

Step 4:

Drive WP- (for 141.4°)
From +107.0° to -34.4°

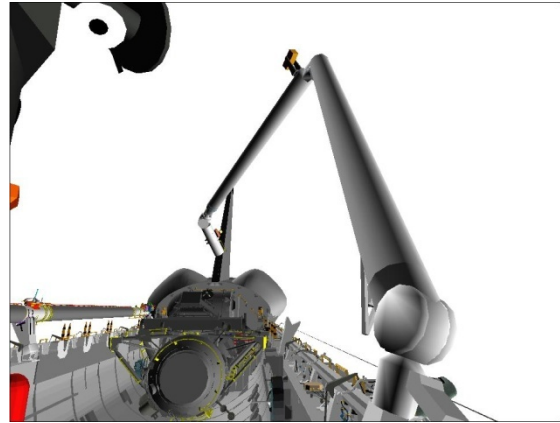

CCTV A (5,15)

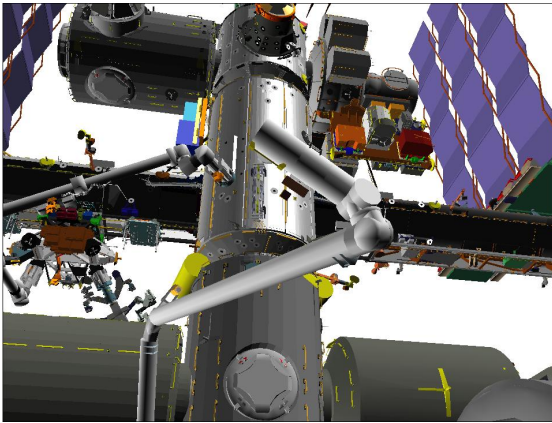

CCTV B (10,35)

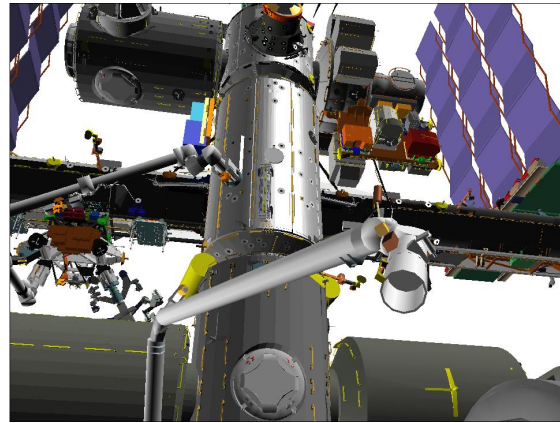

CCTV B (10,35)

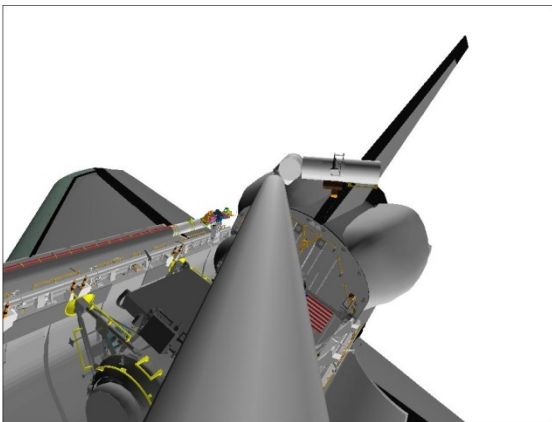

ELBOW (0,-10)

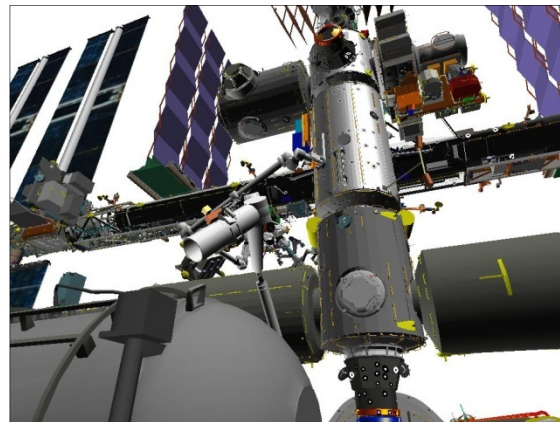

CCTV C (-20,30)

Step 5:

Drive WY- (for 21.4°)
From +48.0° to +26.6°

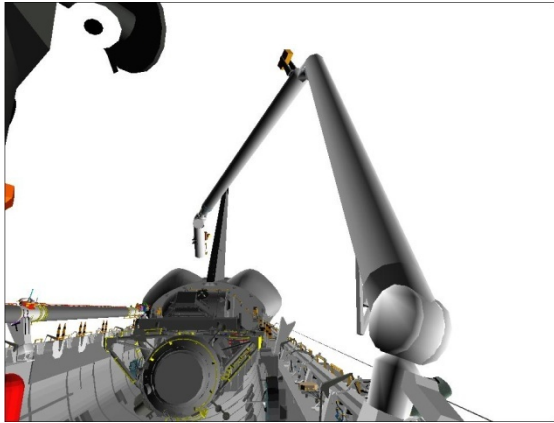

CCTV A (5,15)

Step 6:

Drive WR- (for 41.9°)
From +64.0° to +22.1°

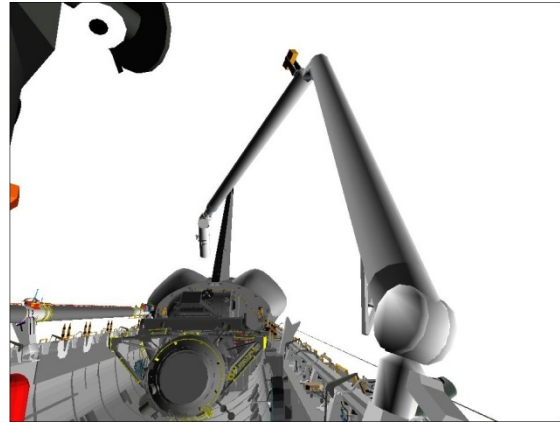

CCTV A (5,15)

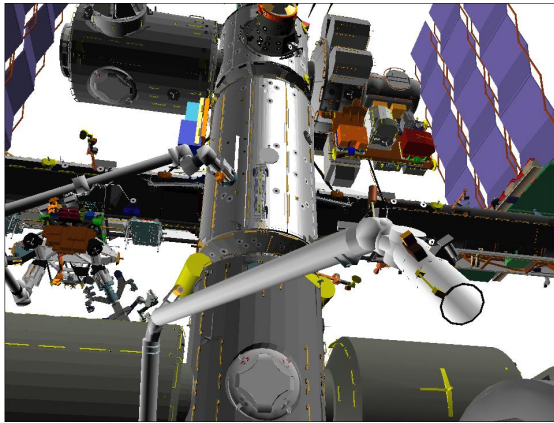

CCTV B (10,35)

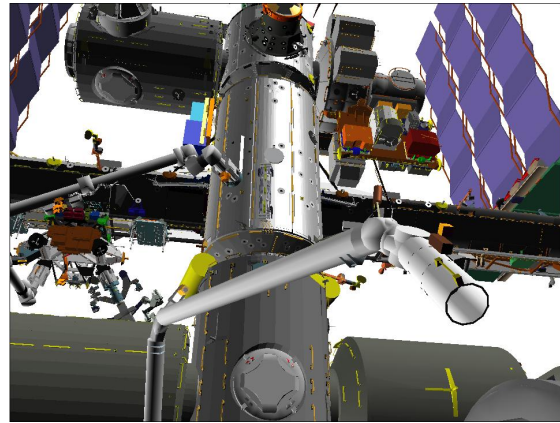

CCTV B (10,35)

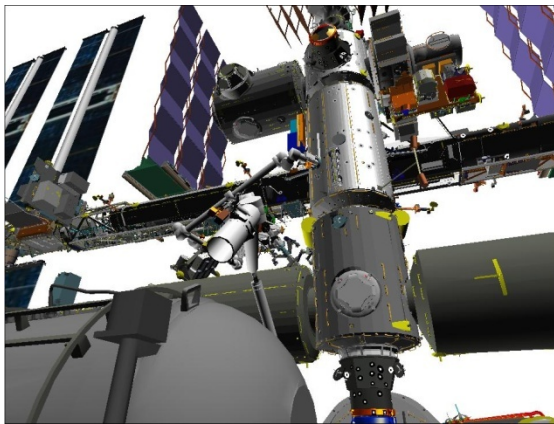

CCTV C (-20,30)

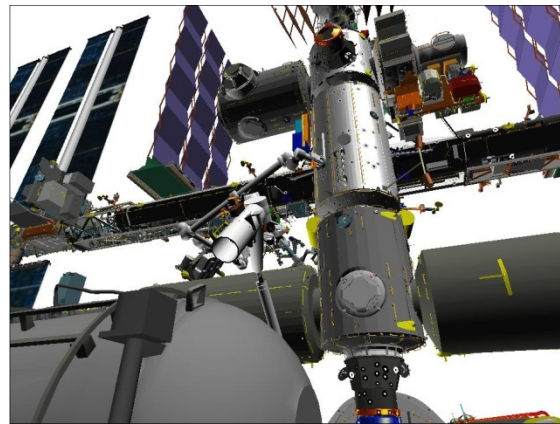

CCTV C (-20,30)

SJ MRM1 GRAPPLE

1. SETUP FOR MRM1 GRAPPLE

Verify SSRMS at MRM1 PRE-GRAPPLE posn:

SR	SY	SP	EP	WP	WY	WR
-39.8	+90.2	-17.2	+45.0	-68.1	-142.9	+58.3

Verify SRMS at MRM1 PRE-GRAPPLE posn:

X	Y	Z	PITCH	YAW	ROLL	PL ID
-1141	0	-525	310	0	0	0
SY	SP	EP	WP	WY	WR	
-18.5	+47.6	-66.9	-34.4	+26.6	+22.1	

R12 √Green Jumper – ISS

V10/L	D
V10/R	P1 LOOB
MON 1	EE
MON 2	A

A7U

CCTV – config for grapple

– install SJ MRM1 GRAPPLE – CCTV OVERLAY

– RMS WRIST, ZOOM: 34.0 HFOV

FOCUS: 5 ft

Maintain eyepoint approx 18 in when using grapple overlay

2. MNVR TO MRM1 GRAPPLE

Notify SSRMS Operator SRMS MRM1 Grapple in work

RHC

If SINGLE MODE available:

√RATE – VERN (RATE MIN tb-ON)

BRAKES – OFF (tb-OFF)

MODE – best available

Drive joints per SJ MRM1 GRAPPLE – CCTV OVERLAY and diagram until EE within grapple envelope

SJ MRM1 GRAPPLE

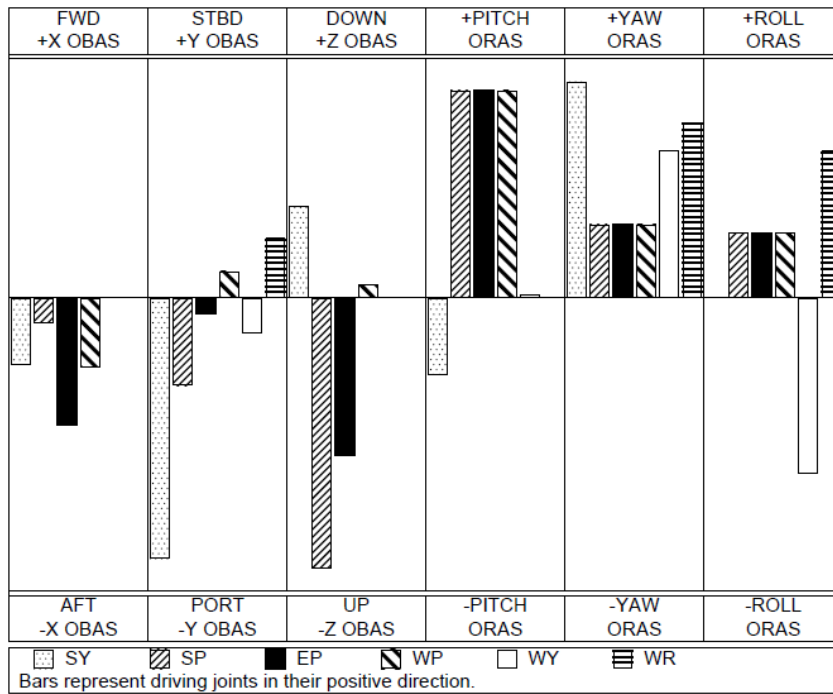

To get:	Drive:	To get:	Drive:	Driving:	Results In:	Driving:	Results In:
+X (fwd)	-EP, -WP	+PITCH	+WP, +EP	+SY	-Y (port), +YAW	+WP	-X (aft), +PITCH
+Y (stbd)	-SY	+YAW	+SY, +WR	+SP	-Z (up), +PITCH	+WY	-Y (port), -ROLL
+Z (down)	-SP, -EP	+ROLL	-WY, +WR	+EP	-Z (up), +PITCH	+WR	+Y (stbd), +YAW

ΔSY	ΔSP	ΔEP	ΔWP	ΔWY	ΔWR
+3.7	-14.4	+13.7	+2.0	-2.3	-2.8

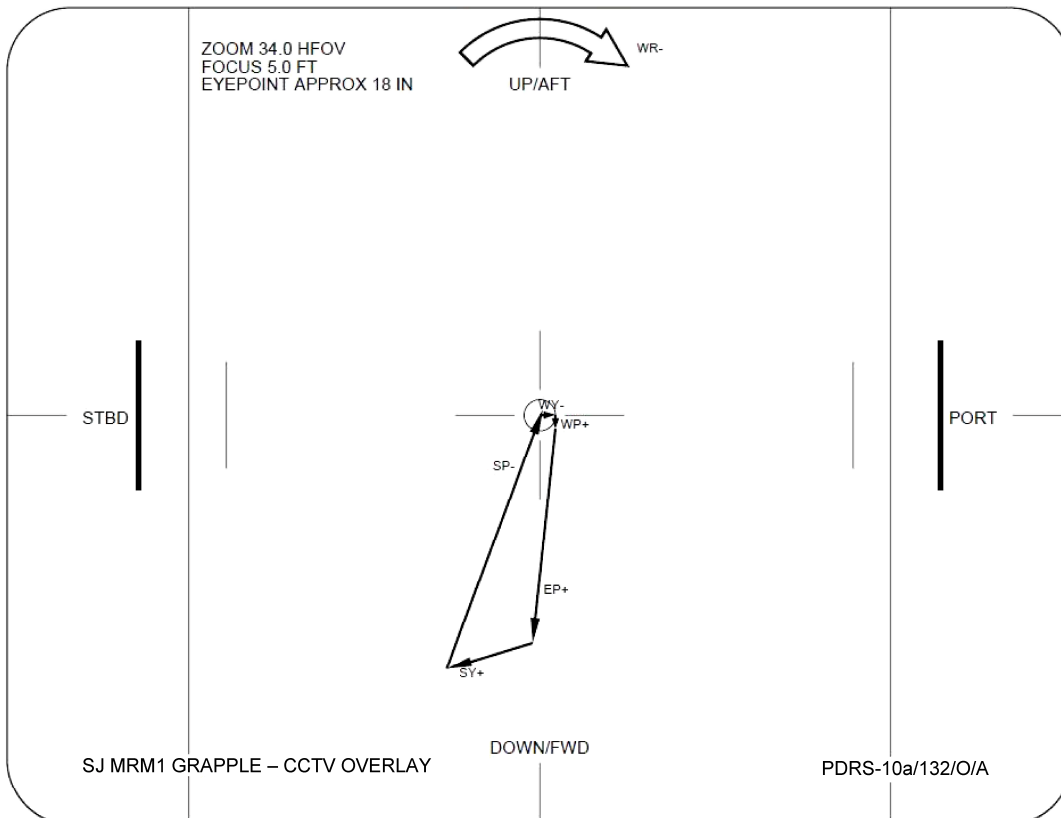

3. MRM1 GRAPPLE

CAUTION
Monitor EE tb timing to prevent EE motor burnout

SM 169 PDRS STATUS

EE MODE – AUTO
CAPTURE sw – depress (mom)

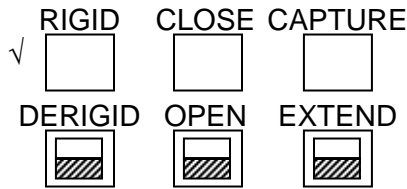

CRITICAL TIMES (28 sec total):
 CAPTURE tb – gray, then
 CLOSE tb – gray, 3 sec max, then
 RIGID tb – gray, 25 sec max

EE MODE – OFF

- * If manual capture required: *
- * EE MODE – MAN *
- * CAPTURE sw – depress (hold until CLOSE tb-gray, 3 sec max) *
- * MAN CONTR – RIGID (hold until RIGID tb-gray, 25 sec max) *
- * MODE – OFF *

BRAKES – ON (tb-ON)
MODE – not DIRECT (lt off)

SM 94 PDRS CONTROL

PL ID – ITEM 3 +3 EXEC
INIT ID – ITEM 24 +3 EXEC

Record POS/ATT and Joint Angles:

	X	Y	Z	PITCH	YAW	ROLL	PL ID
							3
Expected	-1116	0	-414	0	0	0	3
	SY	SP	EP	WP	WY	WR	
Expected	-14.8	+33.1	-53.1	-32.4	+24.3	+19.3	

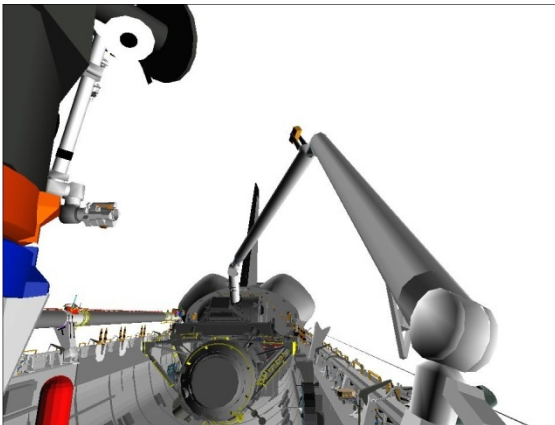

CCTV A (0,15)

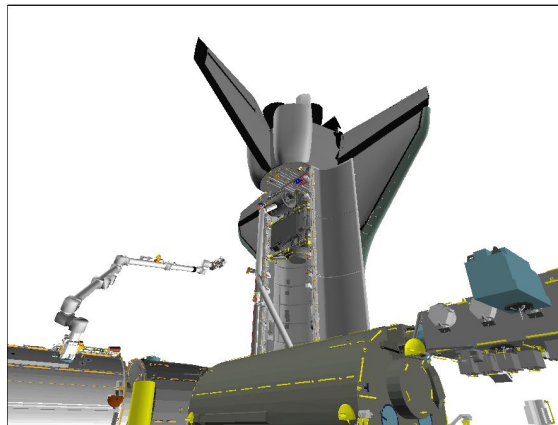

P1 LOOB (130,30)

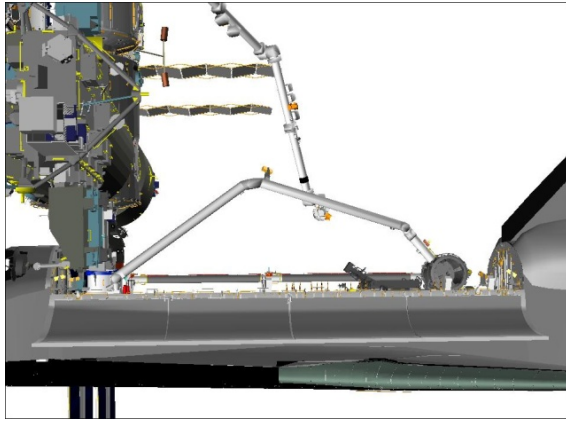

PORT

Review GENERIC END EFFECTOR CUE CARD – ISS/SHUTTLE DOCKED OPS

SJ MRM1 UNBERTH

1. SETUP
Perform MRM1 UNBERTH steps 1 through 7 (MRM1 NOMINAL)
2. MNVR TO MRM1 LOW HOVER POSN

NOTE

Minimum clearance between stbd trunnions and OBSS during unberth is 3.4 inches at approximately Z = -442 (REL = 12). Monitor with SSRMS Tip Elbow Camera.

Minimum clearance between MRM1 probe and aft bulkhead structure during unberth is approximately 18 inches. Monitor with Camera B after MRM1 is clear of V-guides

RHC If SINGLE mode available:
RATE – VERN (RATE MIN tb-ON)
BRAKES – OFF (tb-OFF)

MODE – best available

Drive joints per SJ MRM1 UNBERTH table and histogram to MRM1 LOW HOVER posn

A6U √PL RETEN LAT RDY 1,2,3,4,5 tb (five) – bp

SJ MRM1 Unberth

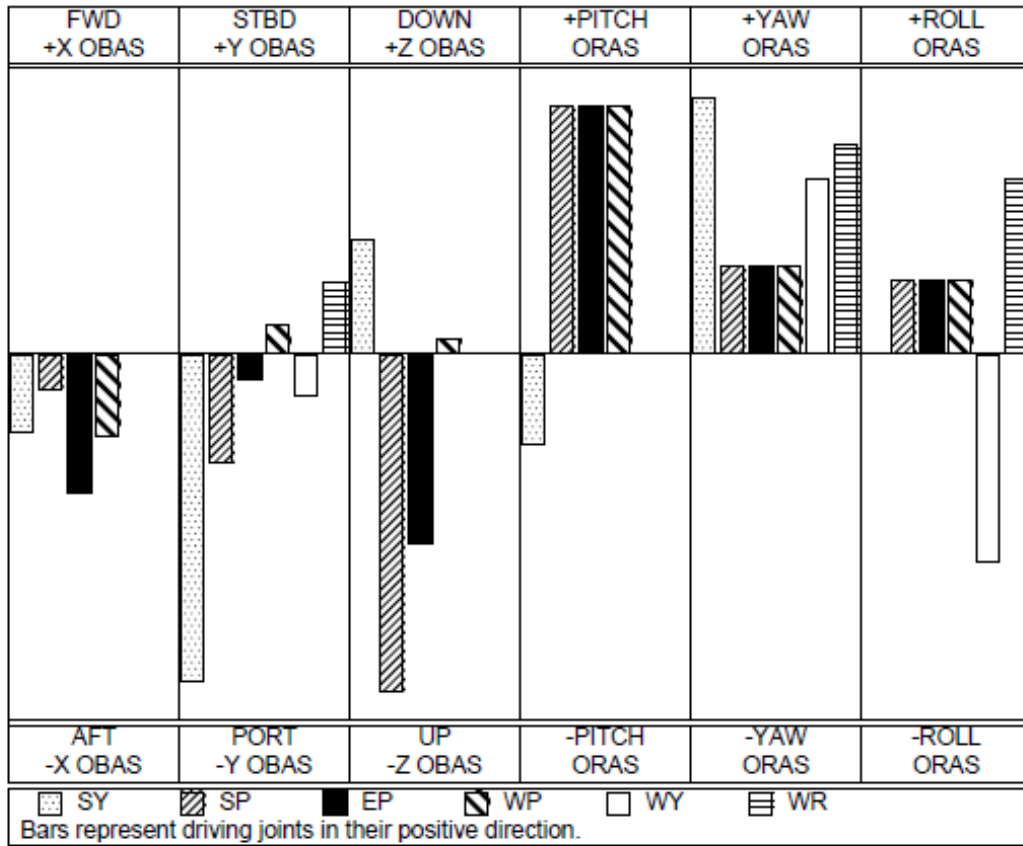

To get:	Drive:	To get:	Drive:	Driving:	Results In:	Driving:	Results In:
+X (fwd)	-EP, -WP	+PITCH	+WP, +EP	+SY	-Y (port), +YAW	+WP	-X (aft), +PITCH
+Y (stbd)	-SY	+YAW	+WR, +SY	+SP	-Z (up), +PITCH	+WY	-Y (port), -ROLL
+Z (down)	-SP, -EP	+ROLL	-WY, +WR	+EP	-Z (up), +PITCH	+WR	+Y (stbd), +YAW

SUGGESTED JOINT ORDER

SP+, SY-, EP+, WP-, WR+, WY+ as req

ΔSY	ΔSP	ΔEP	ΔWP	ΔWY	ΔWR
-1.5	+2.0	+4.5	-7.1	+0.9	+1.3

z	SY	SP	EP	WP	WY	WR
-414	-14.8	+33.2	-53.2	-32.3	+24.3	+19.3
-416	-14.9	+33.3	-53.1	-32.7	+24.3	+19.3
-418	-15.0	+33.4	-52.9	-33.0	+24.4	+19.4
-423	-15.1	+33.7	-52.4	-33.9	+24.5	+19.6
-428	-15.3	+34.0	-51.9	-34.7	+24.6	+19.7
-433	-15.5	+34.3	-51.4	-35.6	+24.7	+19.9
-438	-15.7	+34.5	-50.8	-36.5	+24.8	+20.1
-443	-15.9	+34.8	-50.2	-37.4	+24.9	+20.2
-448	-16.1	+35.0	-49.5	-38.3	+25.1	+20.4
-450	-16.2	+35.0	-49.3	-38.7	+25.1	+20.5
-454	-16.3	+35.2	-48.7	-39.4	+25.2	+20.6

MRM1 LOW HOVER posn:

X	Y	Z	PITCH	YAW	ROLL	PL ID
-1116	0	-454	0	0	0	3
SY	SP	EP	WP	WY	WR	
-16.3	+35.2	-48.7	-39.4	+25.2	+20.6	

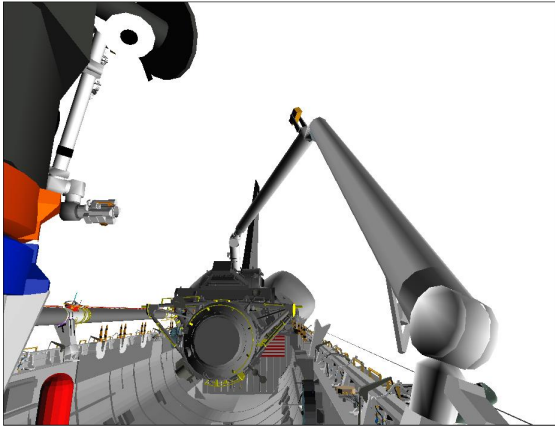

CCTV A (0,15)

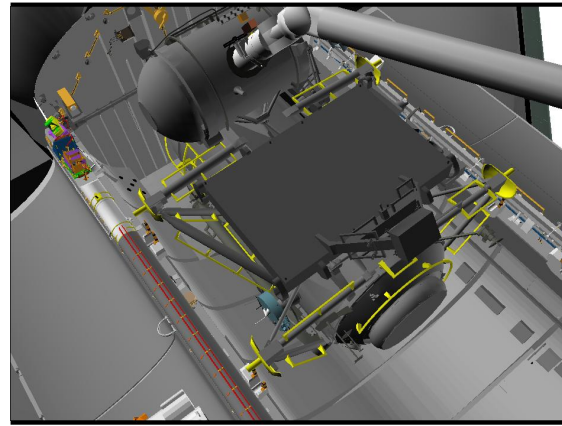

SSRMS TIP ELBOW (20,30)

3. MNVR TO MRM1 HANDOFF POSN

V10/L	D
V10/R	P1 LOOB → SSRMS Tip Elbow
MON 1	C
MON 2	A

NOTE

In line 1 of the SJ table, minimum clearance between MRM1 docking target and PLB is 26 inches. Monitor with Camera A.

In line 3 of the SJ table, minimum clearance between MRM1 radiator and SRMS lower boom is 34 inches. Monitor with SSRMS Tip Elbow

Mnvr to MRM1 HANDOFF posn:

Low Hover	SY	SP	EP	WP	WY	WR	
	-16.3	+35.2	-48.7	-39.4	+25.2	+20.6	
1: SP +		+53.4					
2: EP -			-50.3				
3: WP -				-59.7			
4: WY +					+30.2		
5: WR +						+28.6	
6: SY -	-25.0						
MRM1 H/O	-25.0	+53.4	-50.3	-59.7	+30.2	+28.6	
	X	Y	Z	PITCH	YAW	ROLL	PL ID
	-1045	0	-600	0	0	0	3

BRAKES – ON (tb-ON)
MODE – not DIRECT (lt off)

- * If Orbiter Attitude Control: ROBOTICS ATTITUDE MAINTENANCE *
- * (ORB OPS, REBOOST/DAP) steps 1,2 *

Notify SSRMS Operator SRMS at MRM1 HANDOFF posn with Brakes On,
GO for MRM1 Grapple

Step 1:

Drive SP+ (for 18.2°)
From +35.2° to +53.4°

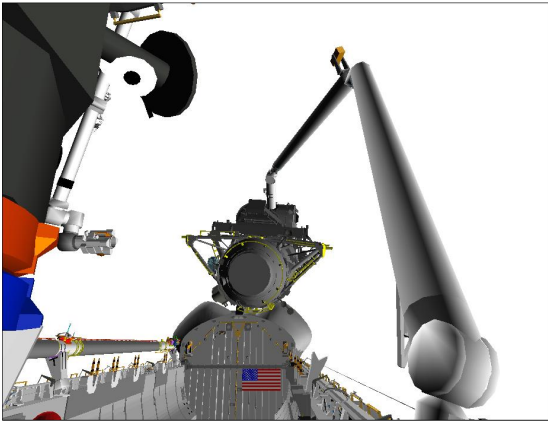

CCTV A (0,20)

Step 2:

Drive EP- (for 1.6°)
From -48.7° to -50.3°

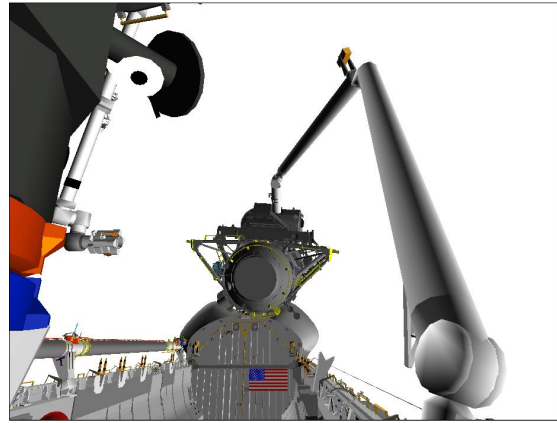

CCTV A (0,20)

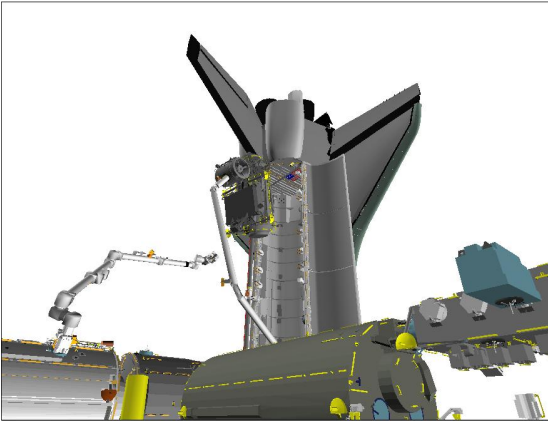

P1 LOOB (130,30)

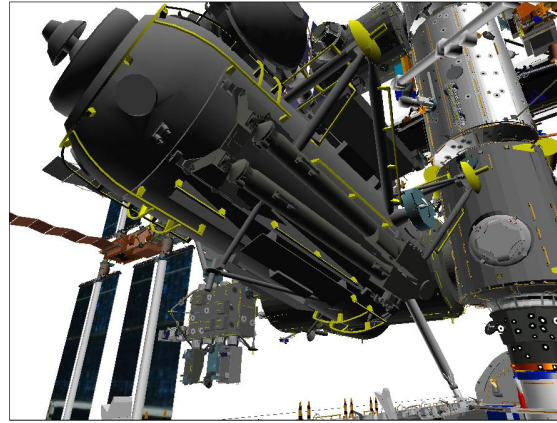

CCTV C (-40,25)

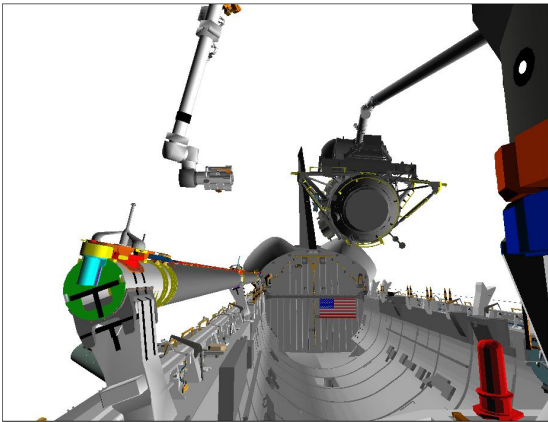

CCTV D (0,10)

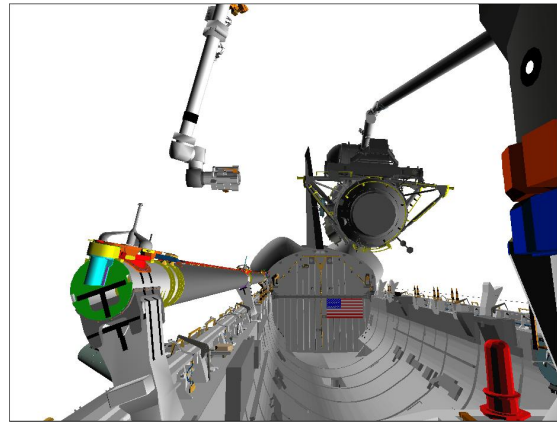

CCTV D (0,10)

Step 3:

Drive WP- (for 20.3°)
From -39.4° to -59.7°

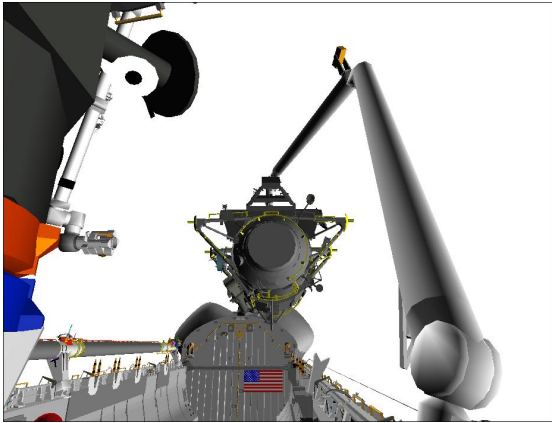

CCTV A (0,20)

Step 4:

Drive WY+ (for 5.0°)
From +25.2° to +30.2°

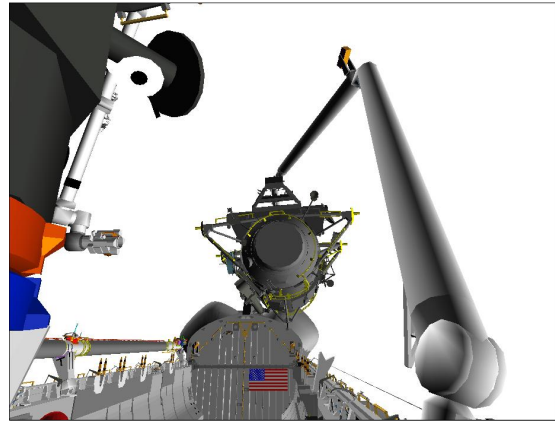

CCTV A (0,20)

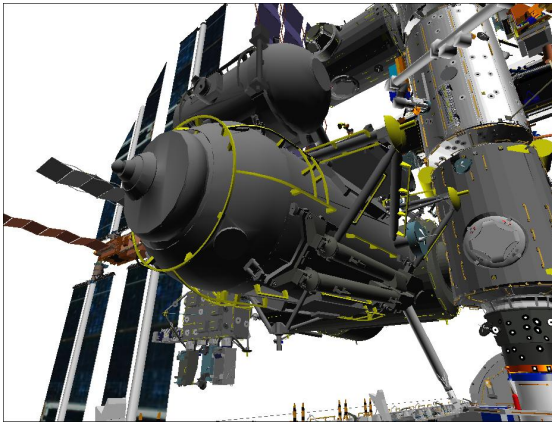

CCTV C (-40,25)

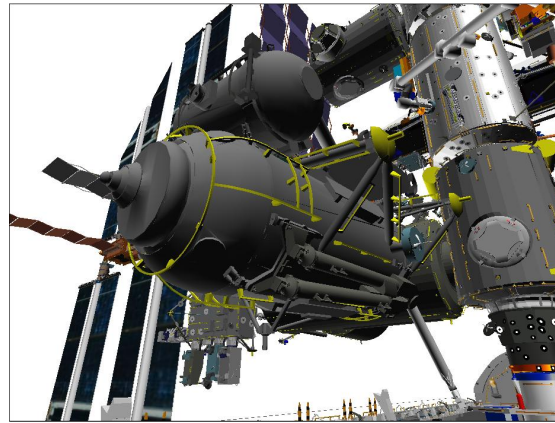

CCTV C (-40,25)

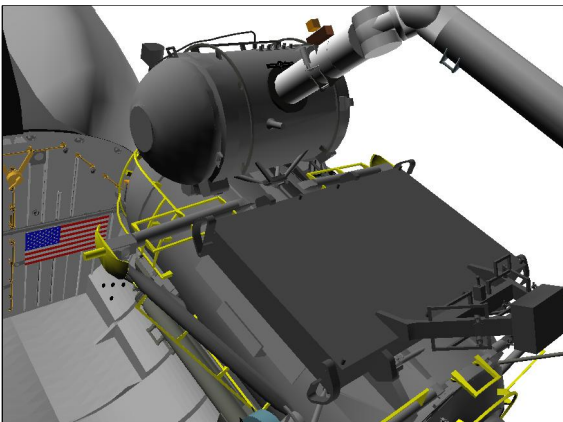

SSRMS TIP ELBOW (40,50)

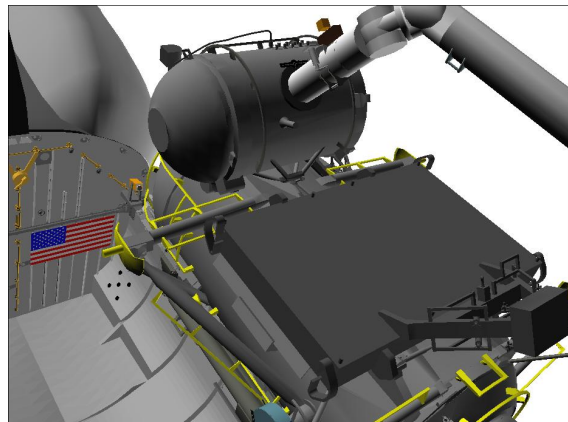

SSRMS TIP ELBOW (40,50)

Step 5:

Drive WR+ (for 8.0°)
From +20.6° to +28.6°

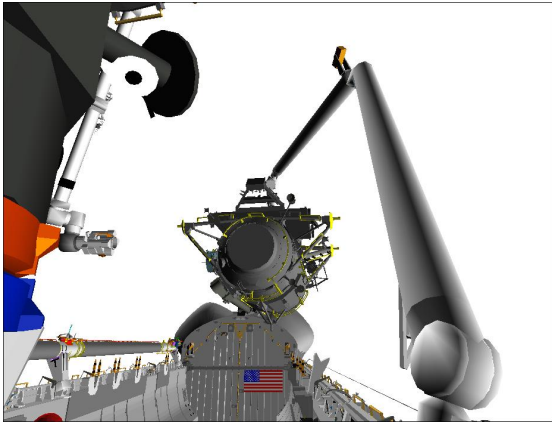

CCTV A (0,20)

Step 6:

Drive SY- (for 8.7°)
From -16.3° to -25.0°

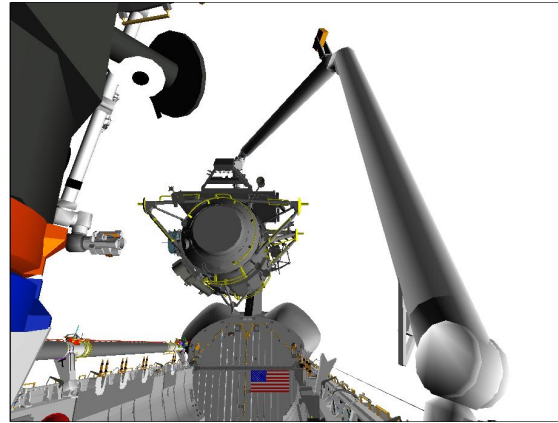

CCTV A (0,20)

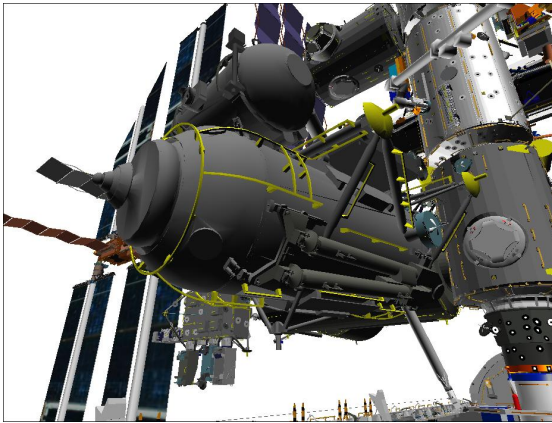

CCTV C (-40,25)

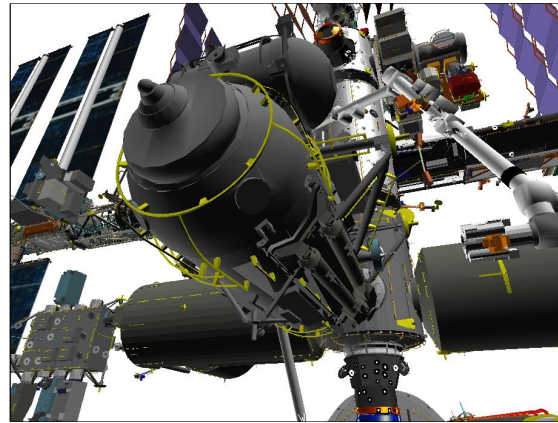

CCTV C (-20,30)

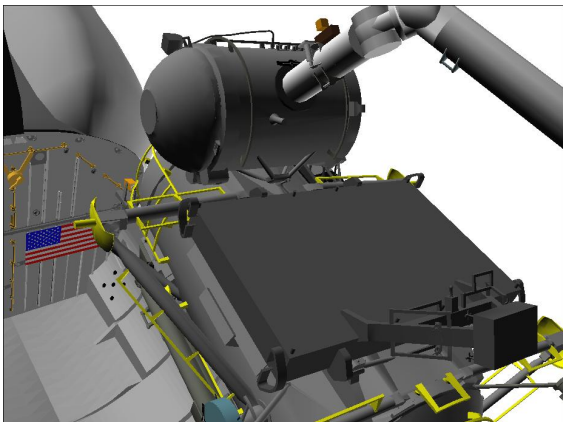

SSRMS TIP ELBOW (40,50)

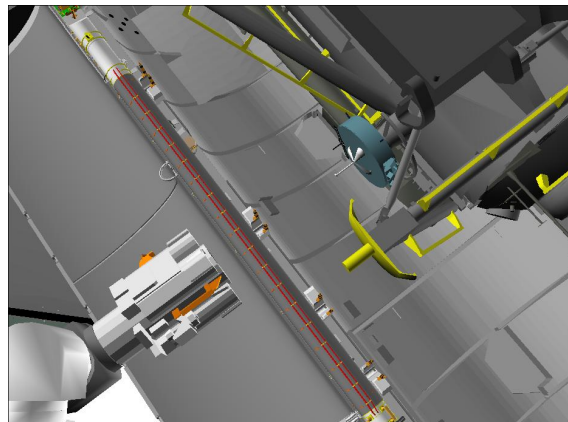

SSRMS TIP ELBOW (20,15)

SJ MRM1 RELEASE

1. MRM1 RELEASE

On SSRMS Operator GO for MRM1 Release,

V10/L	B
V10/R	SSRMS Tip Elbow
MON 1	EE
MON 2	A

CCTV – config for ungrapple

– install SJ MRM1 RELEASE AT HANDOFF – CCTV OVERLAY

– RMS WRIST, ZOOM: 34.0 HFOV

FOCUS: 5 ft

If TEST MODE available:

NOTE

CONTR ERR It and 'S96 PDRS CNTL' msg may occur due to Consistency/Envelope Check error

RHC

RATE – COARSE (RATE MIN tb-OFF)

SM 94 PDRS CONTROL

AUTO BRAKE INH – ITEM 10 EXEC (*)

A8U

BRAKES – OFF (tb-OFF)

MODE – TEST, ENTER

Wait 5 sec

BRAKES – ON (tb-ON)

SM 94 PDRS CONTROL

AUTO BRAKE ENA – ITEM 9 EXEC (*)

If SINGLE MODE available:

SM 94 PDRS CONTROL

PL ID – ITEM 3 +0 EXEC

INIT ID – ITEM 24 +0 EXEC

RHC

RATE – VERN (RATE MIN tb-ON)

BRAKES – OFF (tb-OFF)

MODE – best available

CAUTION

Monitor EE tb timing to prevent EE motor burnout

EE MODE – MAN

MAN CONTR – DERIGID (hold until DERIGID tb-gray, 5 sec max)

RELEASE sw – depress (hold until OPEN tb-gray, 3 sec max)

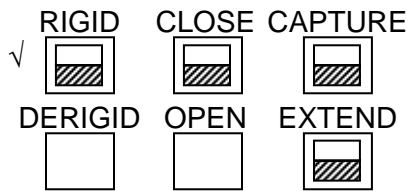

CRITICAL TIMES (8 sec total):
 DERIGID tb – gray, 5 sec max, then
 OPEN tb – gray, 3 sec max

2. MNVR TO MRM1 BACKOFF POSN

Drive joints per SJ MRM1 RELEASE AT HANDOFF – CCTV OVERLAY and histogram

NOTE

Minimum clearance to JEM is 44 inches at BACKOFF posn.
 Monitor with Camera A

Mnvr to MRM1 BACKOFF posn:

X	Y	Z	PITCH	YAW	ROLL	PL ID
-1077	0	-702	310	0	0	0
SY	SP	EP	WP	WY	WR	
-29.2	+59.9	-51.2	-67.6	+32.4	+32.2	

SJ MRM1 RELEASE

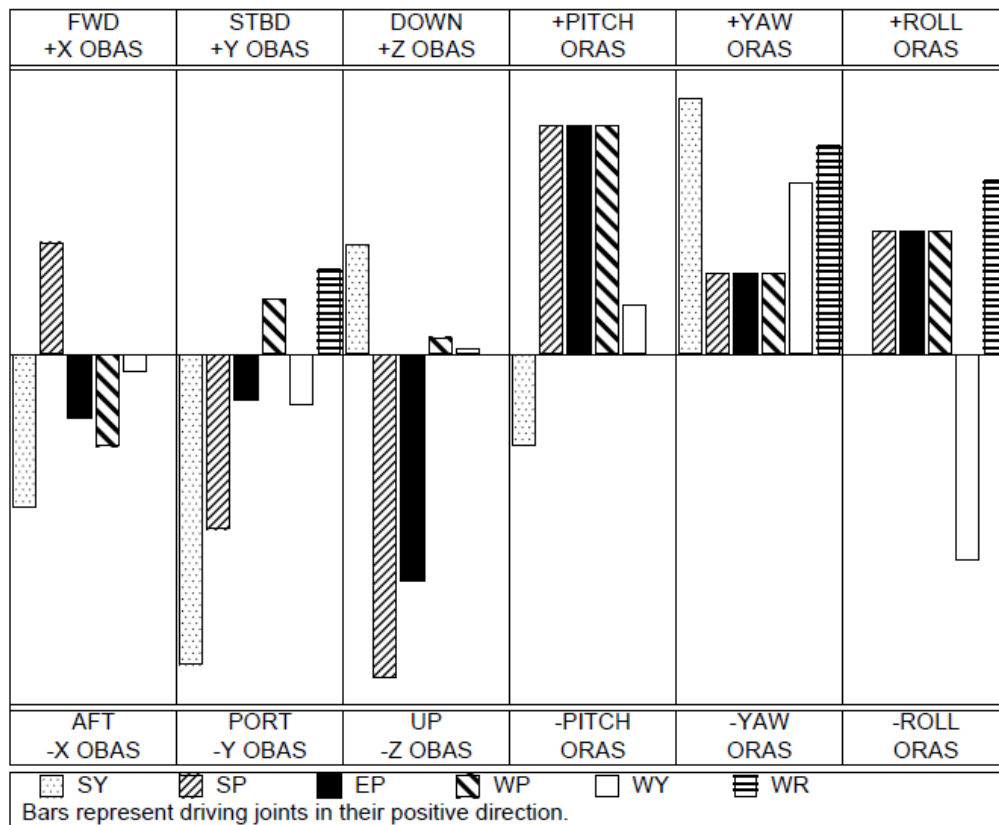

To get:	Drive:	To get:	Drive:
+X (fwd)	-SY, -WP	+PITCH	+WP, +EP
+Y (stbd)	-SY, -SP	+YAW	+SY, +WR
+Z (down)	-SP, -EP	+ROLL	-WY, +WR

Driving:	Results In:	Driving:	Results In:
+SY	-Y (port), +YAW	+WP	-X (aft), +PITCH
+SP	-Z (up), +PITCH	+WY	-Y (port), -ROLL
+EP	-Z (up), +PITCH	+WR	+Y (stbd), +YAW

ΔSY	ΔSP	ΔEP	ΔWP	ΔWY	ΔWR
-4.1	+6.7	-1.0	-7.8	+2.2	+4.1

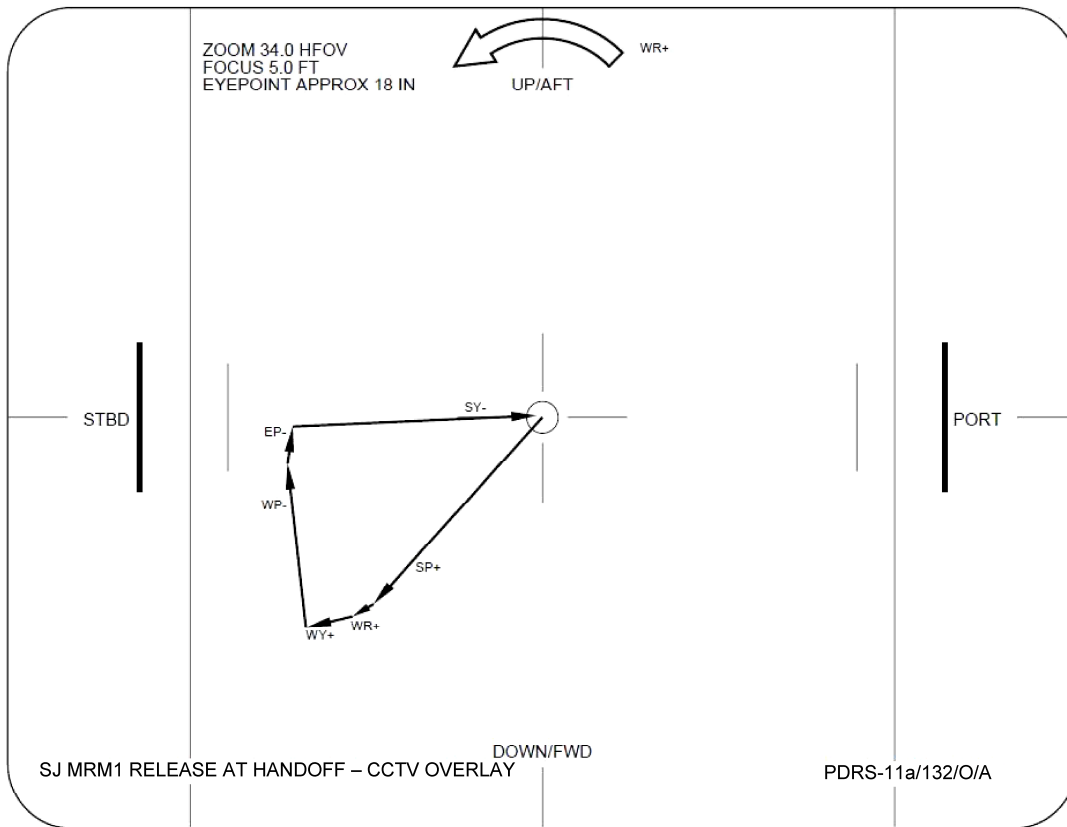

EE MAN CONTR – DERIGID (hold until EXTEND tb-gray, 20 sec max)
MODE – OFF

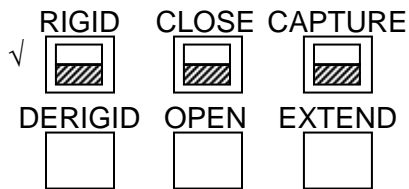

CRITICAL TIMES (20 sec total):
EXTEND tb – gray, 20 sec max

A6U

✓DAP: FREE

GNC 20 DAP CONFIG

Permanently edit CA for DAPs A11, A12, B12, and B13.

See DOCKED DAP REFERENCE (ORB OPS, REBOOST/DAP) for CA.

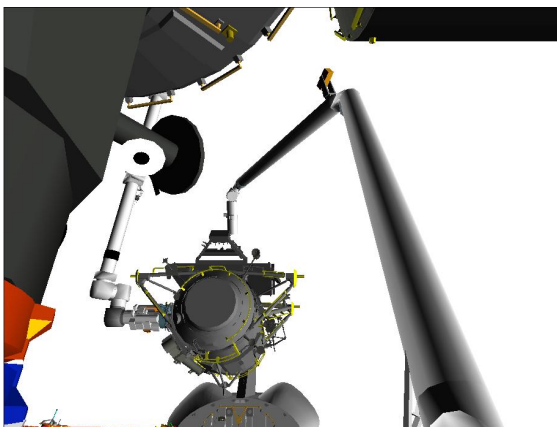

CCTV A (0,30)

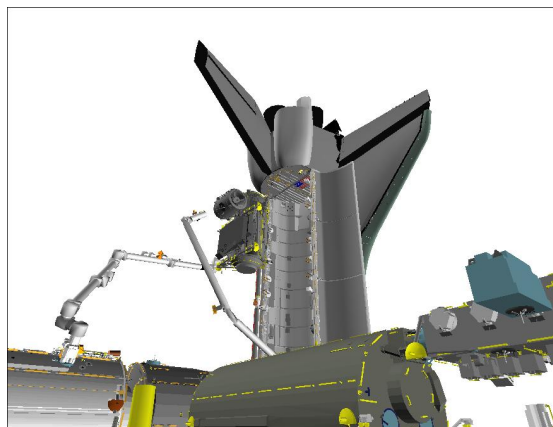

P1 LOOB (130,30)

3. MNVR TO MRM1 CLEARANCE POSN

V10/L	B
V10/R	S1 LOOB
MON 1	Elbow
MON 2	A

NOTE

Minimum clearance between EE and MRM1 during Single Joint SY mnvr to MRM1 CLEARANCE posn is 31 inches. Monitor with S1 LOOB

PARAM – JOINT ANGLE

If SINGLE MODE available:

RHC RATE – as reqd (VERN within 10 ft)
BRAKES – OFF (tb-OFF)

MODE – best available

Mnvr to MRM1 CLEARANCE posn:

	SY	SP	EP	WP	WY	WR	
MRM1 Backoff	-29.2	+59.9	-51.2	-67.6	+32.4	+32.2	
1: SY +	+20.0						
MRM1	+20.0	+59.9	-51.2	-67.6	+32.4	+32.2	
Clearance	X	Y	Z	PITCH	YAW	ROLL	PL ID
	-1081	-345	-580	284	22	42	0

BRAKES – ON (tb-ON)

MODE – not DIRECT (lt off)

PARAM – PORT TEMP

JOINT – CRIT TEMP

Notify SSRMS Operator SRMS at MRM1 CLEARANCE posn with Brakes On, GO for maneuver to MRM1 PRE-DOCK posn

Step 1:

Drive SY+ (for 49.2°)
From -29.2° to +20.0°

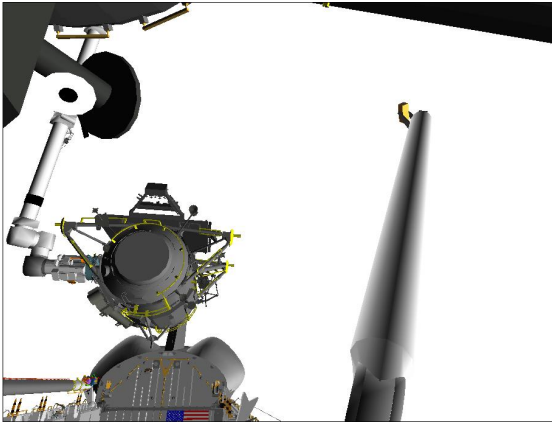

CCTV A (10,25)

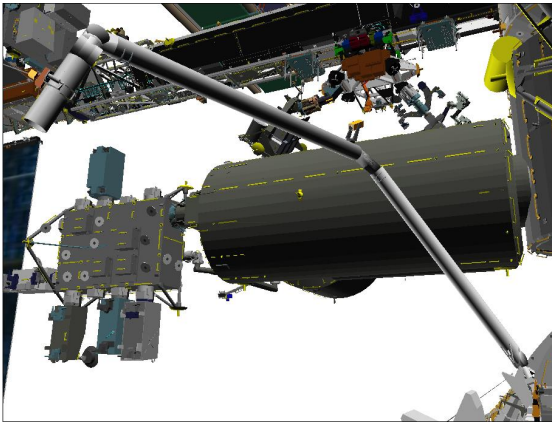

CCTV B (-25,15)

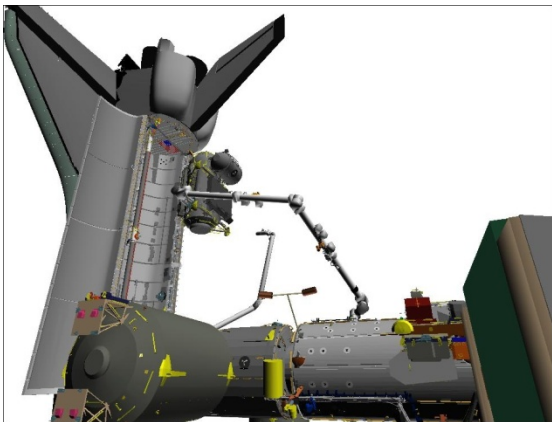

S1 LOOB (70,25)

MRM1 CONTINGENCY REBERTH

1. SETUP

SM 94 PDRS CONTROL

√ PL ID, ITEM 3: 0

√ INIT ID, ITEM 24: 0

Verify SRMS at MRM1 DOCK VIEWING posn:

X	Y	Z	PITCH	YAW	ROLL	PL ID
-870	-465	-777	107	329	279	0
SY	SP	EP	WP	WY	WR	
+52.6	+58.4	-20.3	+103.3	-15.0	-3.4	

R12

√ Green Jumper – ISS

V10/L	B
V10/R	S1 LOOB
MON 1	Elbow
MON 2	A

SM 94 PDRS CONTROL

END POS – ITEM 18 -1 0 3 0 -3 6 7 -6 9 7 EXEC

ATT – ITEM 21 +1 2 5 +4 1 +3 4 0 EXEC

CMD CK – ITEM 25 EXEC (GOOD)

2. MNVR TO MRM1 INTERMEDIATE DOCK VIEWING POSN

Verify SSRMS at MRM1 Handoff posn with Brakes On and SSRMS Operator GO for MNVR TO MRM1 BACKOFF posn

NOTE

Minimum clearance to JEM during OCAS mnvr to MRM1 INTERMEDIATE DOCK VIEWING posn is 39 inches.
Monitor with Camera A

RHC

RATE – VERN (RATE MIN tb-ON)

BRAKES – OFF (tb-OFF)

MODE – OPR CMD, ENTER (READY lt on)

AUTO SEQ – PROCEED (IN PROG lt on)

When AUTO SEQ IN PROG lt – off,

MRM1 INTERMEDIATE DOCK VIEWING posn: (00:45)

X	Y	Z	PITCH	YAW	ROLL	PL ID
-1030	-367	-697	125	41	340	0
SY	SP	EP	WP	WY	WR	
+20.0	+59.9	-51.2	+100.0	+32.4	+32.2	

3. MNVR TO MRM1 BACKOFF POSN

NOTE

In line 2 of the SJ table, minimum clearance between EE and MRM1 is 31 inches. Monitor with S1 LOOB

RHC

RATE – as reqd (VERN within 10 ft)

MODE – SINGLE, ENTER

Mnvr to MRM1 BACKOFF posn:

Intermediate
Dock View
1: WP –
2: SY –
Backoff

SY	SP	EP	WP	WY	WR	
+20.0	+59.9	-51.2	+100.0	+32.4	+32.2	
			-67.6			
-29.2						
-29.2	+59.9	-51.2	-67.6	+32.4	+32.2	
X	Y	Z	PITCH	YAW	ROLL	PL ID
-1077	0	-702	310	0	0	0

BRAKES – ON (tb-ON)

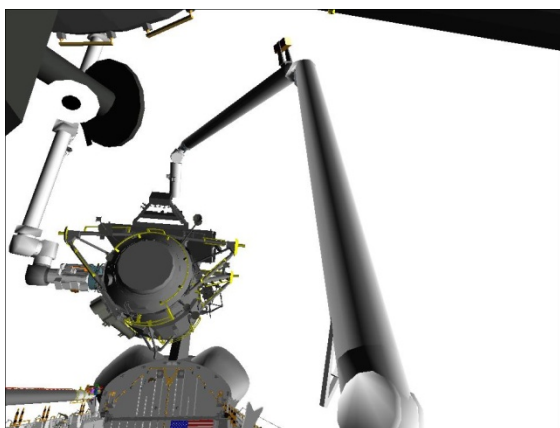

CCTV A (10,25)

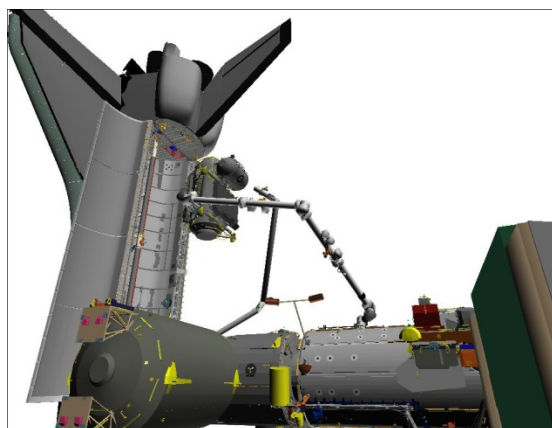

S1 LOOB (70,25)

4. SETUP FOR MRM1 GRAPPLE AT HANDOFF

V10/L	B
V10/R	SSRMS Tip Elbow
MON 1	EE
MON 2	A

A7U

CCTV – config for grapple

– install PDRS TARGET OVERLAY FOR CTVM

– RMS WRIST, ZOOM: 34.0 HFOV

FOCUS: 5 ft

Maintain eyepoint approx 18 in when using grapple overlay

5. MRM1 GRAPPLE AT HANDOFF

Notify SSRMS Operator SRMS MRM1 Grapple in work

RHC

√RATE – VERN (RATE MIN tb-ON)

BRAKES – OFF (tb-OFF)

MODE – END EFF, ENTER

Mnvr to grapple envelope

CAUTION

Monitor EE tb timing to prevent EE motor burnout

SM 169 PDRS STATUS

EE MODE – AUTO

CAPTURE sw – depress (mom)

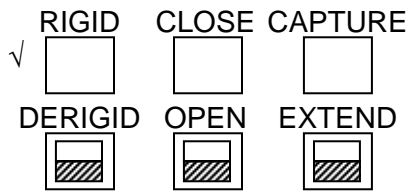

CRITICAL TIMES (28 sec total):
 CAPTURE tb – gray, then
 CLOSE tb – gray, 3 sec max, then
 RIGID tb – gray, 25 sec max

EE MODE – OFF

- * If manual capture required: *
- * EE MODE – MAN *
- * CAPTURE sw – depress (hold until CLOSE tb-gray, 3 sec max) *
- * MAN CONTR – RIGID (hold until RIGID tb-gray, 25 sec max) *
- * MODE – OFF *

MODE – TEST, ENTER
 Wait 5 sec

BRAKES – ON (tb-ON)

SM 94 PDRS CONTROL
 PL ID – ITEM 3 +3 EXEC
 INIT ID – ITEM 24 +3 EXEC

Expected MRM1 HANDOFF posn:

✓	X	Y	Z	PITCH	YAW	ROLL	PL ID
	-1045	0	-600	0	0	0	3
✓	SY	SP	EP	WP	WY	WR	
	-25.0	+53.4	-50.3	-59.7	+30.2	+28.6	

Notify SSRMS Operator grapple complete with Brakes On, GO for MRM1 Release

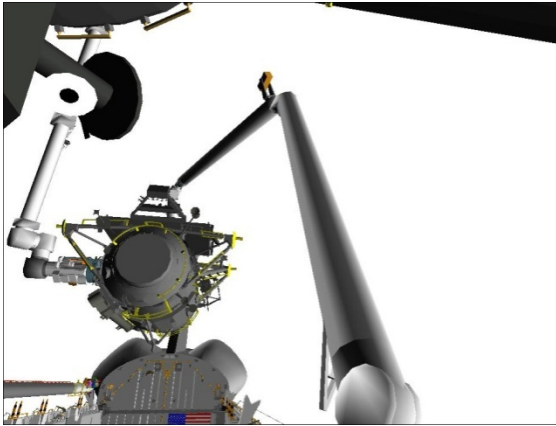

CCTV A (10,25)

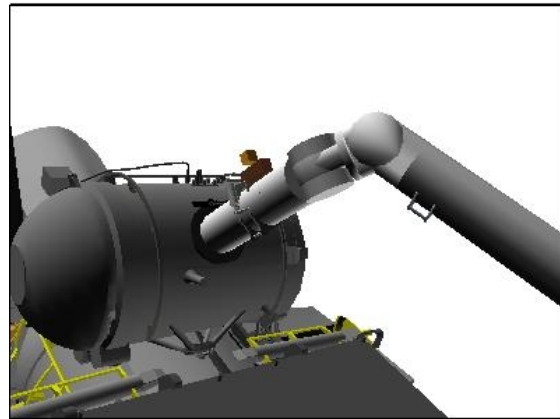

SSRMS TIP ELBOW (40,65)

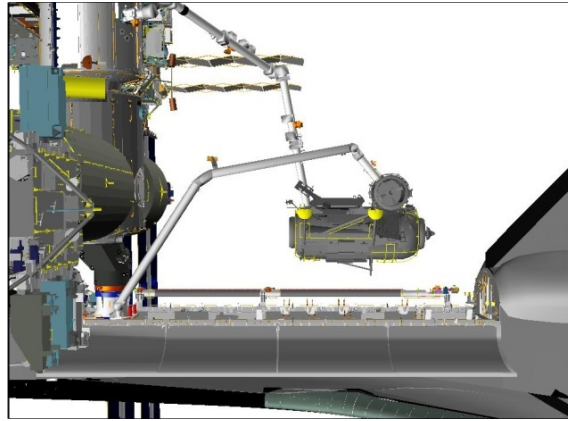

PORT

Review GENERIC END EFFECTOR CUE CARD – ISS/SHUTTLE DOCKED OPS

6. MNVR TO MRM1 LOW HOVER POSN

Verify SSRMS is released, clear, and SSRMS Operator GO for MRM1 Berth

A6U

√DAP: FREE

GNC 20 DAP CONFIG

Permanently edit CA for DAPs A11, A12, B12, and B13

See DOCKED DAP REFERENCE (ORB OPS, REBOOST/DAP) for CA

- * If Orbiter Attitude Control: ROBOTICS ATTITUDE MAINTENANCE *
- * (ORB OPS, REBOOST/DAP) steps 1-3 *

If MRM1 Probe Removal necessary,
perform MRM1 PROBE REMOVAL

R12

√Green Jumper – ISS

V10/L	B
V10/R	US LAB
MON 1	C
MON 2	A

NOTE

Monitor clearance between MRM1 probe and aft bulkhead structure during reberth with Camera B

RHC

√RATE – VERN (RATE MIN tb-ON)

BRAKES – OFF (tb-OFF)

MODE – ORB LD, ENTER

THC

Mnvr MRM1 +Z (THC down) and -X (THC push) to MRM1 LOW HOVER posn:

X	Y	Z	PITCH	YAW	ROLL	PL ID
-1116	0	-454	0	0	0	3
SY	SP	EP	WP	WY	WR	
-16.3	+35.2	-48.7	-39.4	+25.2	+20.6	

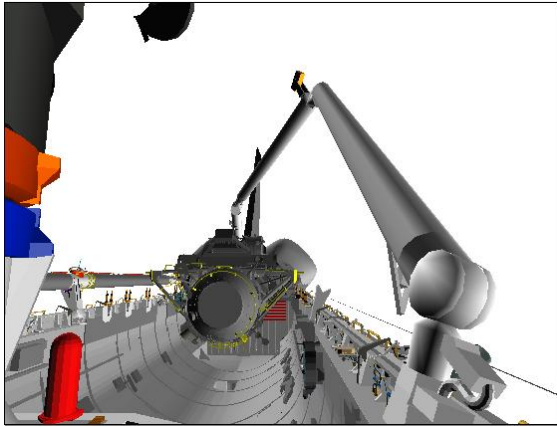

CCTVA (0,10)

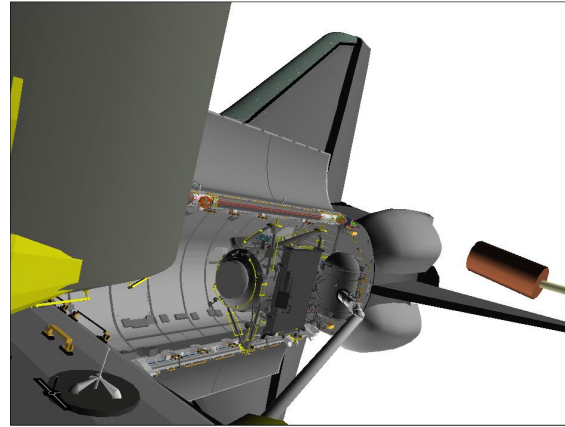

US LAB (-40,-20)

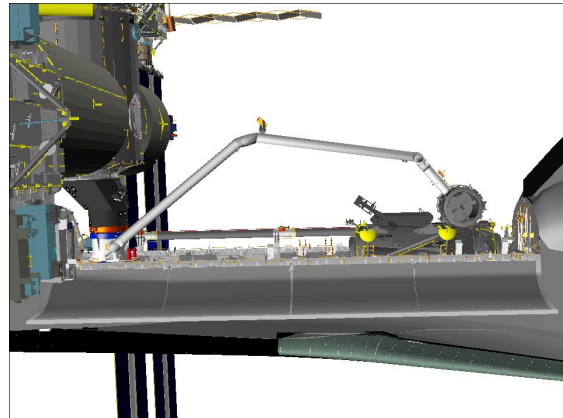

PORT

7. MNVR TO MRM1 BERTH POSN

V10/L	Elbow
V10/R	US LAB → P1 LOOB
MON 1	B/C Mux
MON 2	D/A Mux

NOTE

Minimum clearance between stbd trunnions and OBSS during reberth is expected to be 3.4 inches at approximately Z = -442 (REL = 12). Monitor with Camera C

A6U √PL RETEN PL SEL – 3

Mnvr MRM1 +Z (THC down) to BERTH posn (Z = -414 expected)

MRM1 BERTH posn:

X	Y	Z	PITCH	YAW	ROLL	PL ID
-1116	0	-414	0	0	0	3
SY	SP	EP	WP	WY	WR	
-14.8	+33.1	-53.1	-32.4	+24.3	+19.3	

A6U √PL RETEN LAT RDY 1,2,3,4 tb (four) – gray

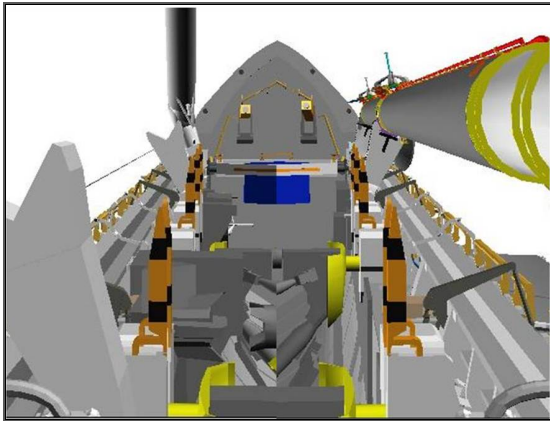

MUX B/C

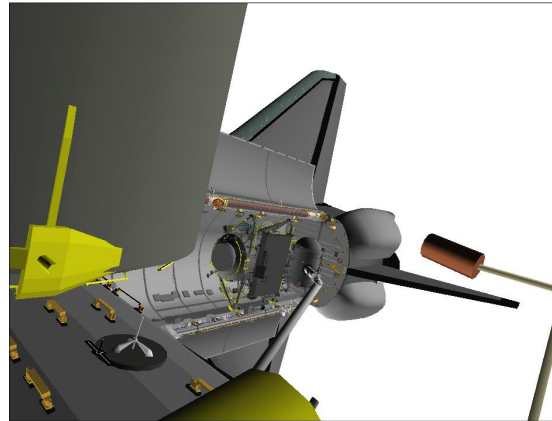

US LAB (-40,-20)

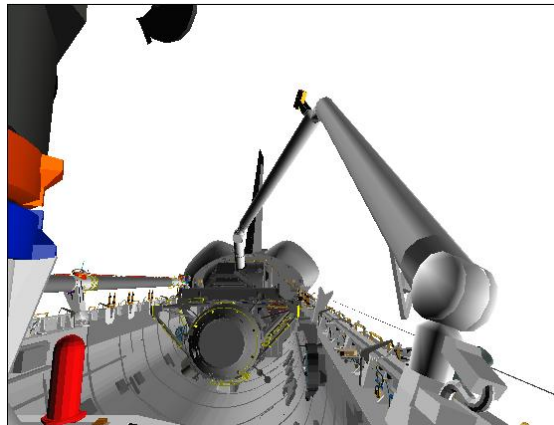

CCTV A (0,10)

8. ACTIVATE LATCHES

NOTE

When MCA LOGIC switches taken OFF, KU will mode to standby. MPM and MRL tbs – bp

MA73C:A MCA LOGIC MNC MID 2 – OFF
 :B MNB MID 4 – OFF

A6U √PL RETEN LAT 1,2,3,4,5 (five) – OFF
 LOGIC PWR SYS 1,2 (two) – ON

R13L BAY MECH PWR SYS 1,2 (two) – ON

SM 97 PL RETENTION

√PL SEL 3 RDY-FOR-LAT 1,2,3,4 (eight): 1
 √LAT 1,2,3,4,5 (ten) : 0

- * If any LAT msw shows '1', *
- * expect single motor time (60 sec) *

9. AKA LATCH

A6U √PL RETEN LAT 5 tb – REL
 √RDY 5 tb – bp

Note single motor time (> 30 sec)

PL RETEN LAT 5 – LAT (tb-LAT), 60 sec max
 – OFF
 √RDY 5 tb – gray

√PL RETEN LAT RDY 1,2,3,4 tb (four) – gray

A6U,
 CRT

- * If any PL RETEN LAT RDY tb – bp or any RDY-FOR-LAT: 0, *
- * √MCC for GO to perform the following: *
- * A6U √PL RETEN LAT 5 tb – LAT *
- * *
- * Note single motor time (> 30 sec) *
- * *
- * PL RETEN LAT 5 – REL (tb-REL), 60 sec max *
- * – OFF *
- * *
- * Mnv to MRM1 BERTH posn (until PL RETEN LAT *
- * RDY 1,2,3,4 tb (four) – gray) *
- * *
- * Repeat step 9 *

10. PRLA LATCH

A6U

√PL RETEN LAT 1,2,3,4 tb (four) – REL
 √RDY 1,2,3,4 tb (four) – gray

Note single motor times (> 30 sec)

PL RETEN LAT 1,2 (two) – LAT (tb-LAT), 60 sec max
 – OFF
 3,4 (two) – LAT (tb-LAT), 60 sec max
 – OFF

BRAKES – ON (tb-ON)

- * If Orbiter Attitude Control: ROBOTICS ATTITUDE MAINTENANCE *
- * (ORB OPS, REBOOST/DAP) steps 1,2 *

11. DEACTIVATE LATCHES

A6U
 R13L

PL RETEN LOGIC PWR SYS 1,2 (two) – OFF
 BAY MECH PWR SYS 1,2 (two) – OFF

MA73C:A
 :B

MCA LOGIC MNC MID 2 – ON
 MNB MID 4 – ON

12. MRM1 RELEASE

V10/L	D
V10/R	P1 LOOB
MON 1	EE
MON 2	A

A7U

CCTV – configure for ungrapple
 – RMS WRIST, ZOOM: 34.0 HFOV
 FOCUS: 5 ft

SM 94 PDRS CONTROL

PL ID – ITEM 3 +0 EXEC
 INIT ID – ITEM 24 +0 EXEC

RHC ✓RATE – VERN (RATE MIN tb-ON)
 BRAKES – OFF (tb-OFF)
 MODE – END EFF, ENTER

When OPEN tb – gray, mnvr arm clear of GF

EE MODE – AUTO
 RELEASE sw – depress (mom)

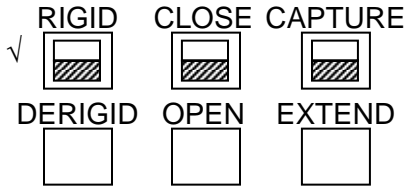

CRITICAL TIMES (28 sec total):
 DERIGID tb – gray, 5 sec max, then
 OPEN tb – gray, 3 sec max, then
 EXTEND tb – gray, 20 sec max

EE MODE – OFF

- * If manual release reqd: *
- * EE MODE – MAN *
- * MAN CONTR – DERIGID (hold until DERIGID tb-gray, 5 sec max) *
- * RELEASE sw – depress (hold until OPEN tb-gray, 3 sec max) *
- * *
- * Mnvr clear of grapple pin *
- * EE MAN CONTR – DERIGID (hold until EXTEND tb-gray, 20 sec max) *
- * MODE – OFF *

THC/RHC Mnvr to MRM1 PRE-GRAPPLE posn:

X	Y	Z	PITCH	YAW	ROLL	PL ID
-1141	0	-525	310	0	0	0
SY	SP	EP	WP	WY	WR	
-18.5	+47.6	-66.9	-34.4	+26.6	+22.1	

BRAKES – ON (tb-ON)

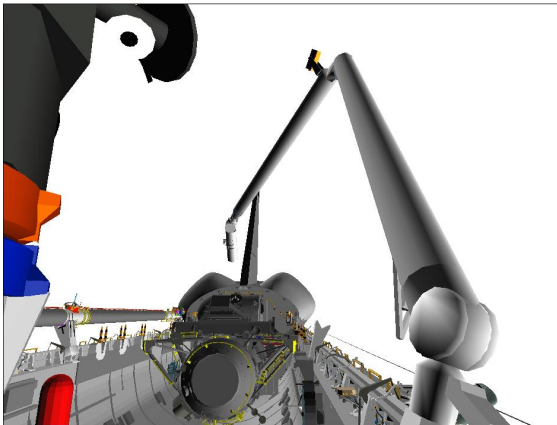

CCTV A (0,15)

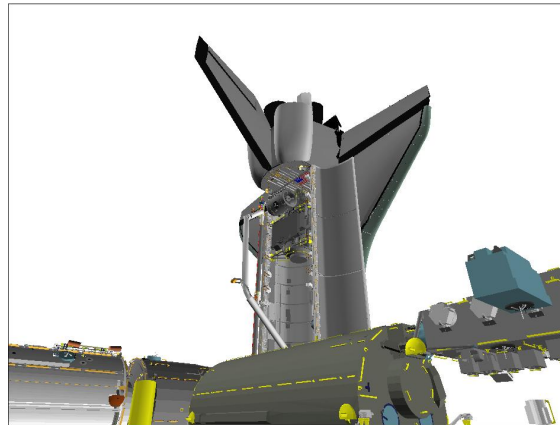

P1 LOOB (130,30)

R12 13. MNVR TO PRE-CRADLE
 ✓Green Jumper – ISS

V10/L	D
V10/R	S1 LOOB
MON 1	B
MON 2	A

NOTE

Minimum clearance between EE and MRM1 during OCAS mnvr to pre-cradle is 55 inches. Monitor with Camera B

SM 94 PDRS CONTROL

END POS – ITEM 18 -1 2 6 1 -1 4 6 -5 5 1 EXEC

ATT – ITEM 21 +5 +2 +0 EXEC

CMD CK – ITEM 25 EXEC (GOOD)

RHC

RATE – VERN (RATE MIN tb-ON)

BRAKES – OFF (tb-OFF)

MODE – OPR CMD, ENTER (READY It on)

AUTO SEQ – PROCEED (IN PROG It on)

When AUTO SEQ IN PROG It – off:

BRAKES – ON (tb-ON)

PRE-CRADLE posn:

(00:45)

X	Y	Z	PITCH	YAW	ROLL	PL ID
✓ -1261	-146	-551	5	2	0	0
	SY	SP	EP	WP	WY	WR
✓ 0.0	+25.0	-25.0	+5.0	0.0	0.0	

PARAM – PORT TEMP

JOINT – CRIT TEMP

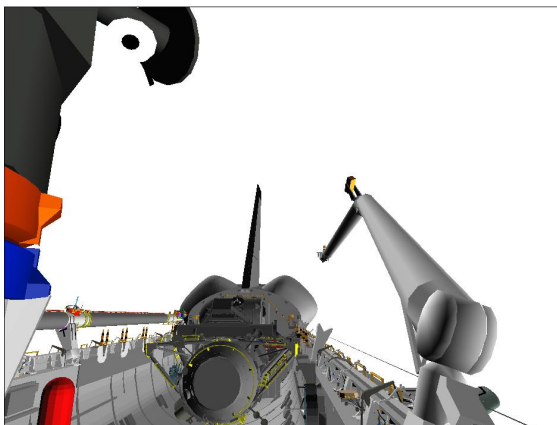

CCTV A (0,15)

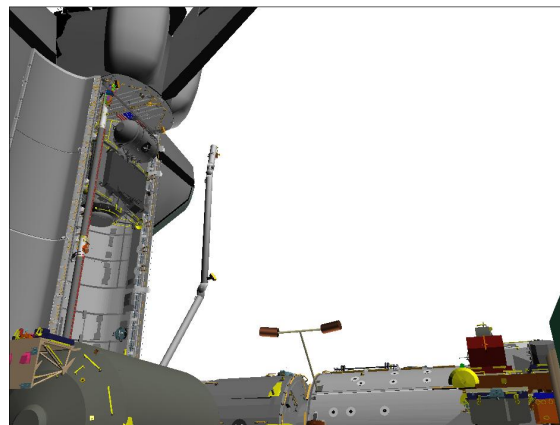

S1 LOOB (70,25)

MRM1 PROBE REMOVAL

1. SETUP

NOTE

Shuttle attitude control allowed when SRMS at published positions

SM 94 PDRS CONTROL

√ PL ID, ITEM 3: 3

√ INIT ID, ITEM 24: 3

Verify SRMS at MRM1 HANDOFF posn:

	X	Y	Z	PITCH	YAW	ROLL	PL ID
√	-1045	0	-600	0	0	0	3
	SY	SP	EP	WP	WY	WR	
√	-25.0	+53.4	-50.3	-59.7	+30.2	+28.6	

R12

√ Green Jumper – ISS

V10/L	C
V10/R	S1 LOOB
MON 1	A
MON 2	B

SM 94 PDRS CONTROL

END POS – ITEM 18 -1 0 1 2 -1 2 8 -6 2 9 EXEC

ATT – ITEM 21 +2 7 0 +2 8 5 +2 7 0 EXEC

CMD CK – ITEM 25 EXEC (GOOD)

2. MNVR TO MRM1 PROBE REMOVAL BACKOFF POSN

On MCC GO for mnvr to MRM1 PROBE REMOVAL BACKOFF posn,

NOTE

Minimum clearance to JEM during OCAS mnvr to MRM PROBE REMOVAL BACKOFF posn is 18 inches. Monitor with Camera A

RHC

RATE – VERN (RATE MIN tb-ON)

BRAKES – OFF (tb-OFF)

MODE – OPR CMD, ENTER (READY lt on)

AUTO SEQ – PROCEED (IN PROG lt on)

When AUTO SEQ IN PROG lt – off:

BRAKES – ON (tb-ON)

MRM1 PROBE REMOVAL BACKOFF posn:

(06:30)

	X	Y	Z	PITCH	YAW	ROLL	PL ID
√	-1012	-128	-629	270	285	270	3
	SY	SP	EP	WP	WY	WR	
√	-21.0	+73.2	-70.0	-91.3	-5.2	-48.9	

Notify MCC SRMS at MRM1 PROBE REMOVAL BACKOFF posn with Brakes ON

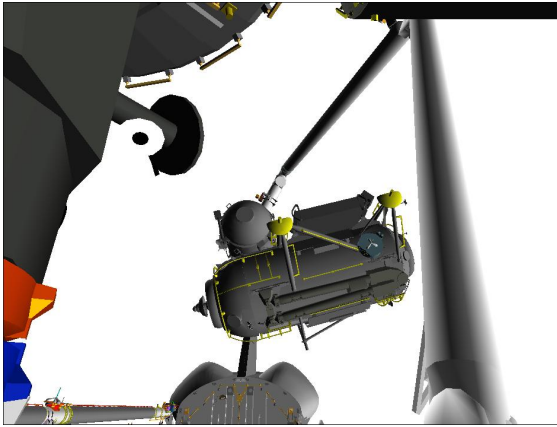

CCTV A (0,28)

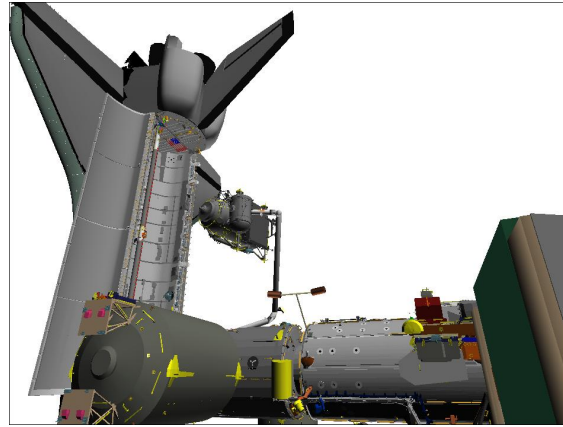

S1 LOOB (70,25)

3. MNVR TO MRM1 PROBE REMOVAL POSN

V10/L	C
V10/R	US LAB
MON 1	A
MON 2	B

NOTE

Monitor clearance to JEM during mnvr to MRM1 PROBE REMOVAL posn with Camera A.

Monitor clearance between MRM1 and Port V-guides during mnvr to MRM1 PROBE REMOVAL posn with Camera B

RHC

- √RATE – VERN (RATE MIN tb-ON)
- BRAKES – OFF (tb-OFF)
- MODE – PL, ENTER

EVA GCA to MRM1 PROBE REMOVAL posn

Expected MRM1 PROBE REMOVAL posn:

X	Y	Z	PITCH	YAW	ROLL	PL ID
-1012	-70	-554	270	285	270	3
SY	SP	EP	WP	WY	WR	
-25.3	+68.9	-83.0	-73.5	-5.0	-44.6	

BRAKES – ON (tb-ON)

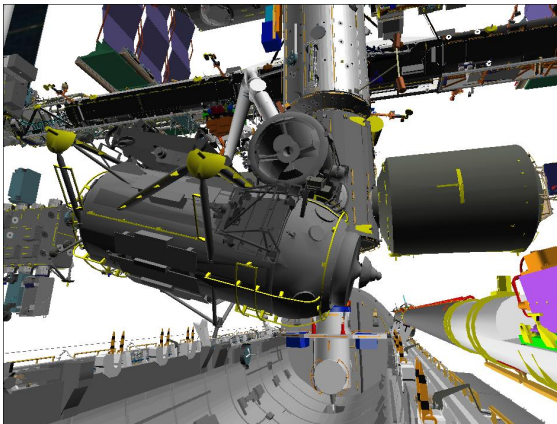

CCTV C (-15,15)

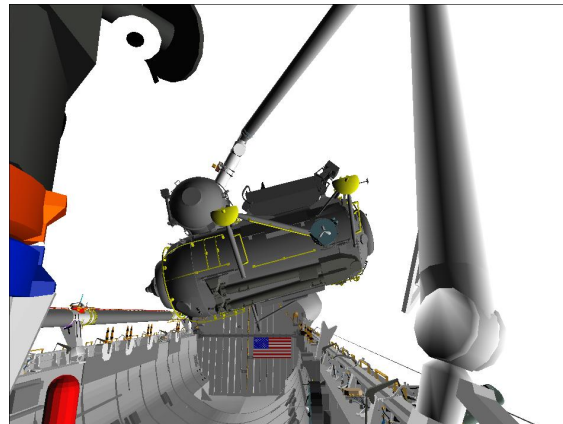

CCTV A (0,15)

4. MNVR BACK TO MRM1 PROBE REMOVAL BACKOFF POSN
 On EVA GO for mnvr back to MRM1 PROBE REMOVAL BACKOFF posn,

V10/L	C
V10/R	S1 LOOB
MON 1	A
MON 2	B

NOTE

Monitor clearance to JEM during mnvr to MRM1 PROBE REMOVAL BACKOFF posn with Camera A.

Monitor clearance between MRM1 and Port V-guides during mnvr to MRM1 PROBE REMOVAL BACKOFF posn with Camera B

RHC √RATE – VERN (RATE MIN tb-ON)
 BRAKES – OFF (tb-OFF)
 MODE – as desired

THC/RHC Mnvr to MRM1 PROBE REMOVAL BACKOFF posn:

X	Y	Z	PITCH	YAW	ROLL	PL ID
-1012	-128	-629	270	285	270	3
SY	SP	EP	WP	WY	WR	
-21.0	+73.2	-70.0	-91.3	-5.2	-48.9	

BRAKES – ON (tb-ON)

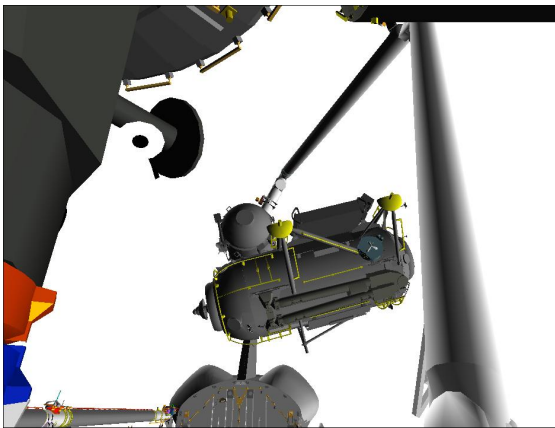

CCTV A (0,28)

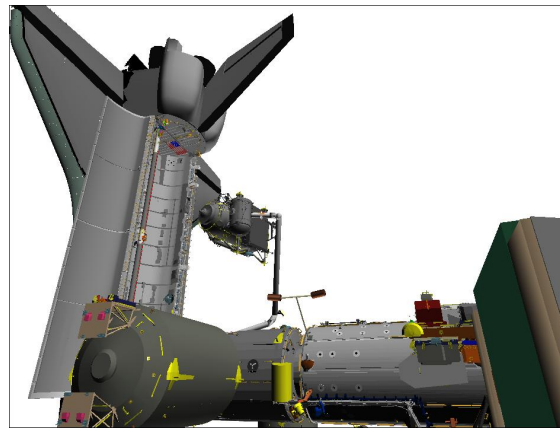

S1 LOOB (70,25)

5. MNVR TO MRM1 HANDOFF POSN
 On MCC GO for MNVR TO HANDOFF posn,

SM 94 PDRS CONTROL

END POS – ITEM 18 -1 0 4 5 +0 -6 0 0 EXEC
 ATT – ITEM 21 +0 +0 +0 EXEC
 CMD CK – ITEM 25 EXEC (GOOD)

RHC RATE – VERN (RATE MIN tb-ON)
 BRAKES – OFF (tb-OFF)
 MODE – OPR CMD, ENTER (READY It on)

AUTO SEQ – PROCEED (IN PROG It on)

When AUTO SEQ IN PROG It – off:
BRAKES – ON (tb-ON)

MRM1 HANDOFF posn:

(06:30)

	X	Y	Z	PITCH	YAW	ROLL	PL ID
√	-1045	0	-600	0	0	0	3
	SY	SP	EP	WP	WY	WR	
√	-25.0	+53.4	-50.3	-59.7	+30.2	+28.6	

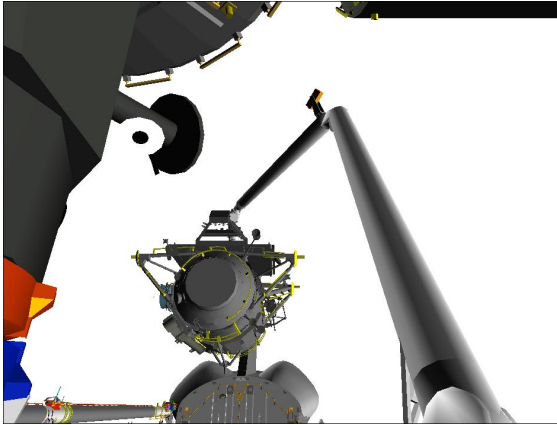

CCTV A (0,28)

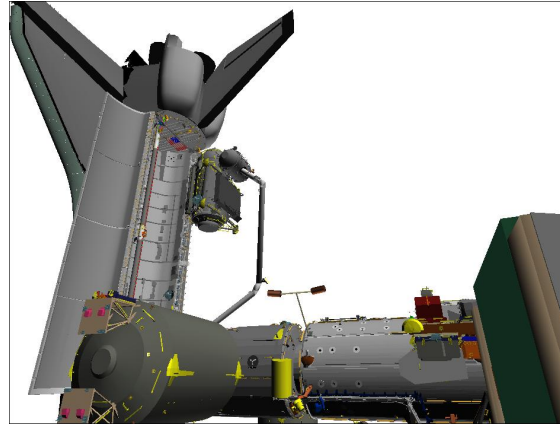

S1 LOOB (70,25)

OBSS OFF-NOMINAL

SJ OBSS GRAPPLE FROM SSRMS	FS 5-2
OBSS HANDBACK TO SSRMS	FS 5-11
BATTERY R&R VIEWING TO OBSS SENSOR PROTECT	FS 5-15
OBSS SENSOR PROTECT TO BATTERY R&R VIEWING	FS 5-17

OBSS
OFF-NOMINAL

SJ OBSS GRAPPLE FROM SSRMS

1. SETUP

Verify SSRMS at MRM1 BACKOFF posn:

SR	SY	SP	EP	WP	WY	WR
+7.2	+108.8	-17.3	-89.9	-156.0	-177.8	-101.2

R12

√Green Jumper – ISS

V10/L	A
V10/R	P1 LOOB
MON 1	B
MON 2	EE

SM 94 PDRS CONTROL

√PL ID, ITEM 3: 0

√INIT ID, ITEM 24: 0

A7U

CCTV – configure as reqd
 – perform PAN/TILT RESET for PLB cameras
 ZOOM – full OUT

2. SINGLE JOINT MANEUVER TO OBSS HANDOFF PRE-GRAPPLE

NOTE

Clearance between SRMS Upper Boom and JPM is 45 inches after SP mnvr. Monitor with Camera A

If SINGLE mode available:

RHC

RATE – as reqd (VERN within 10 ft)
 BRAKES – OFF (tb-OFF)

MODE – best available

Mnvr to OBSS HANDOFF PRE-GRAPPLE posn:

	SY	SP	EP	WP	WY	WR	
MRM1 Clear	+20.0	+59.9	-51.2	-67.6	+32.4	+32.2	
1: SY +	+24.0						
2: SP +		+64.8					
3: EP +			-34.4				
4: WP –				-99.4			
5: WY –					+11.3		
6: WR –						-99.0	
OBSS Handoff Pre-Grapple	+24.0	+64.8	-34.4	-99.4	+11.3	-99.0	
	X	Y	Z	PITCH	YAW	ROLL	PL ID
	-1018	-362	-676	284	0	270	0

BRAKES – ON (tb-ON)
 MODE – not DIRECT

Notify SSRMS Operator SRMS at OBSS Handoff Pre-grapple posn with Brakes On,
 GO for OBSS Unberth

OBSS
OFF-NOMINAL

Start:
MRM1 Clearance

Step 1:
Drive SY+ (for 4.0°)
From +20.0 to +24.0

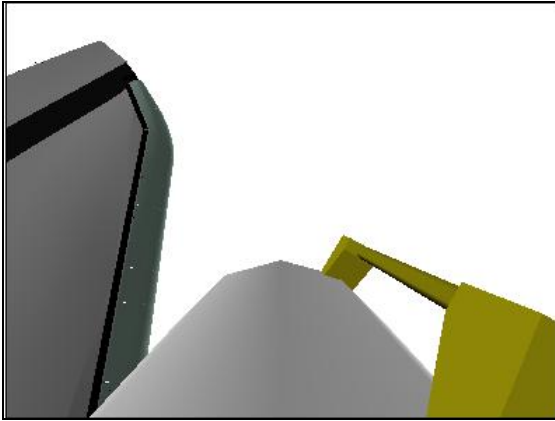

EE

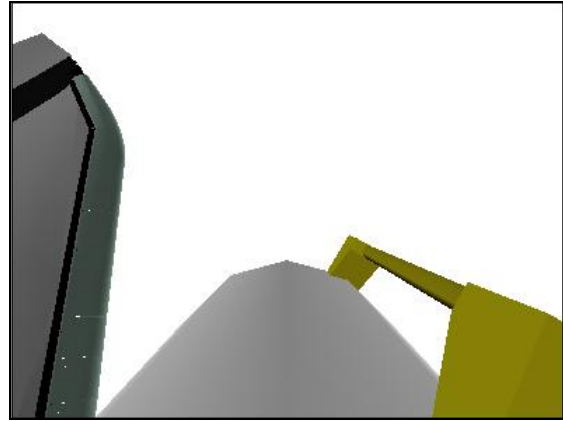

EE

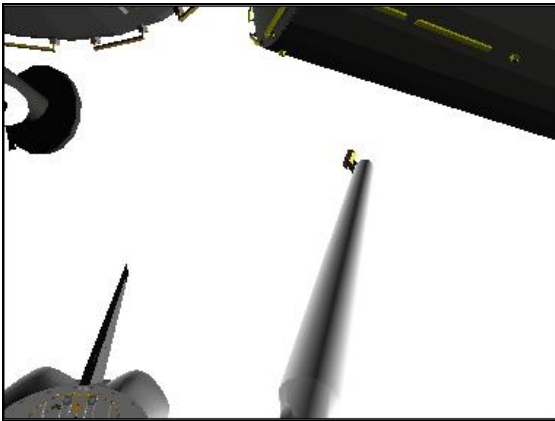

CCTV A (20,30)



CCTV A (20,30)

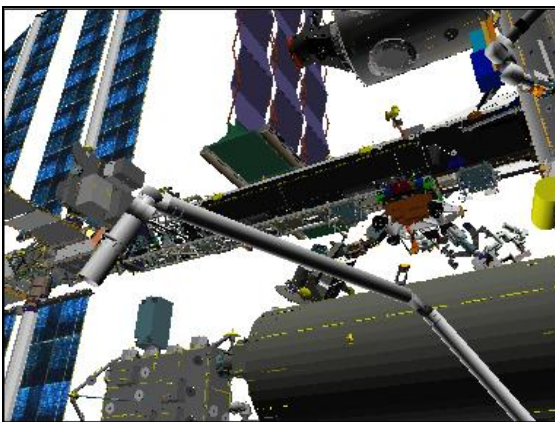

CCTV B (-30,30)

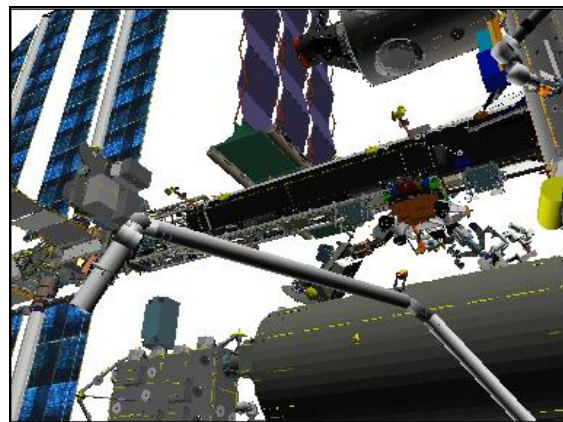

CCTV B (-30,30)

Step 2:

Drive SP+ (for 4.9°)
From +59.9 to +64.8

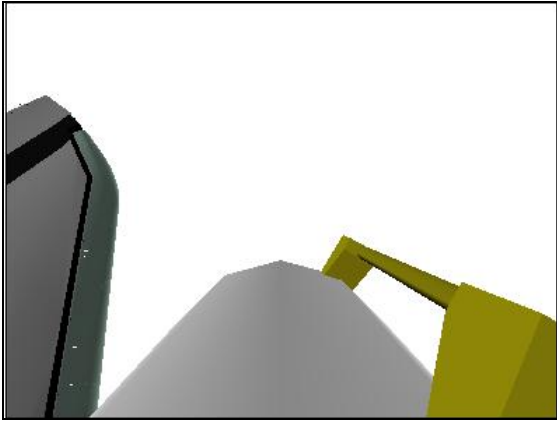

EE

Step 3:

Drive EP+ (for 16.8°)
From -51.2 to -34.4

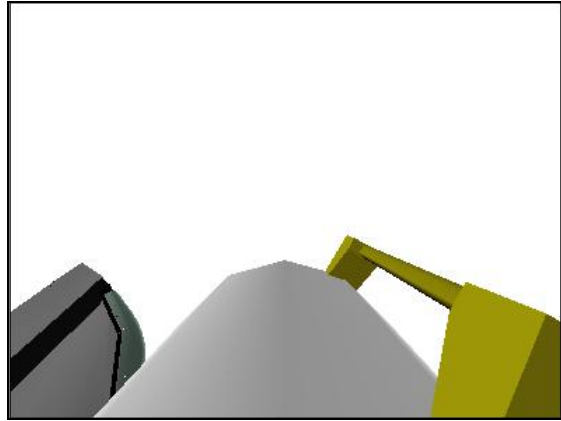

EE

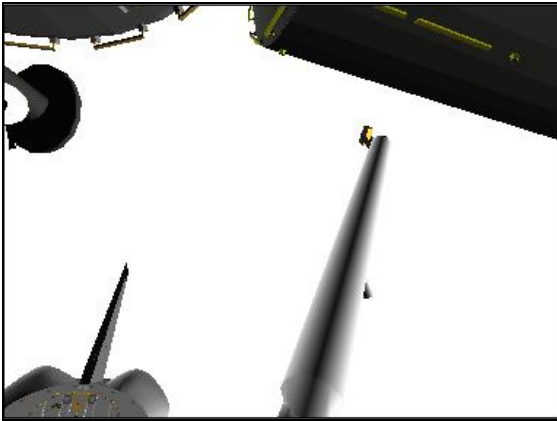

CCTV A (20,30)

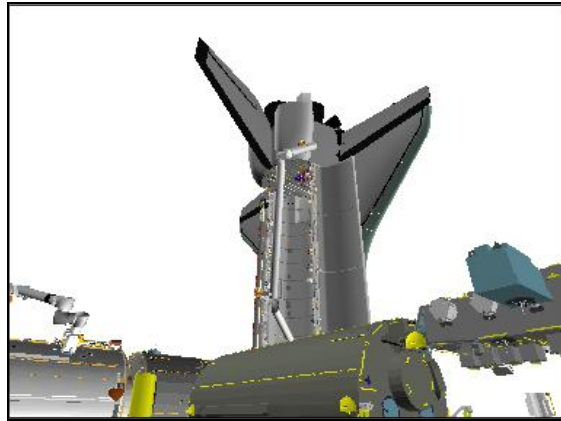

P1 LOOB (130,30)

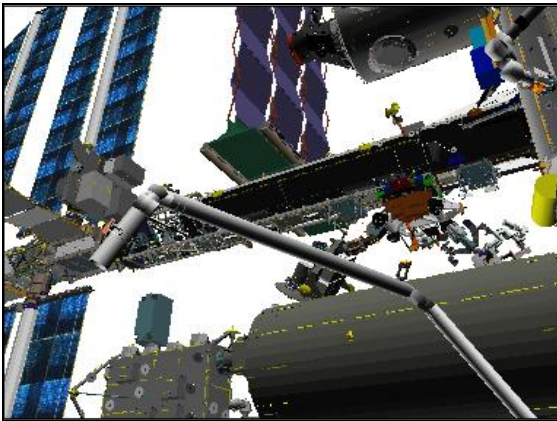

CCTV B (-30,30)

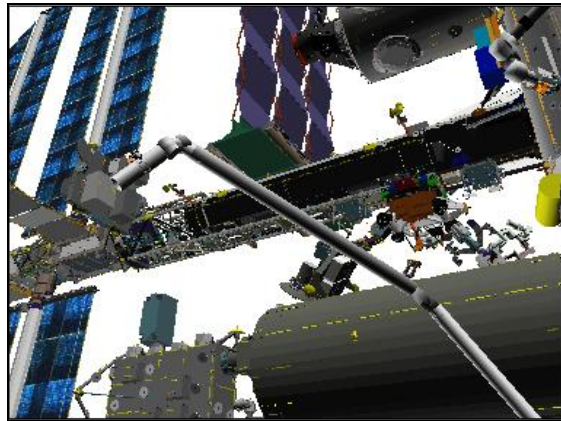

CCTV B (-30,30)

Step 4:

Drive WP- (for 31.8°)
From -67.6 to -99.4

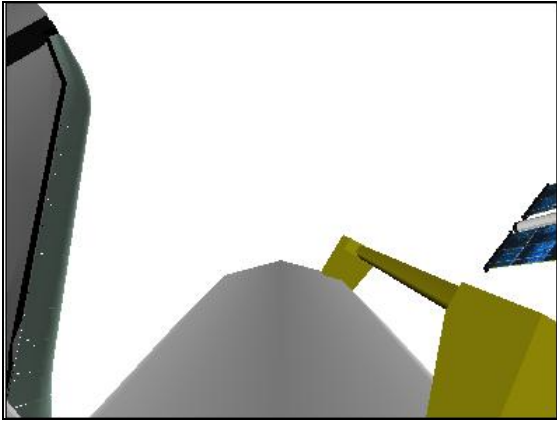

EE

Step 5:

Drive WY- (for 21.1°)
From +32.4 to +11.3

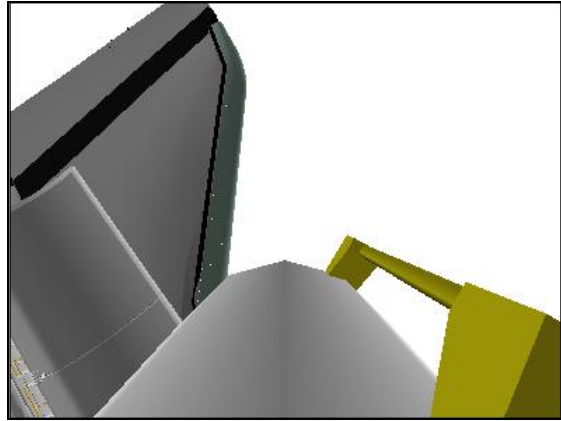

EE

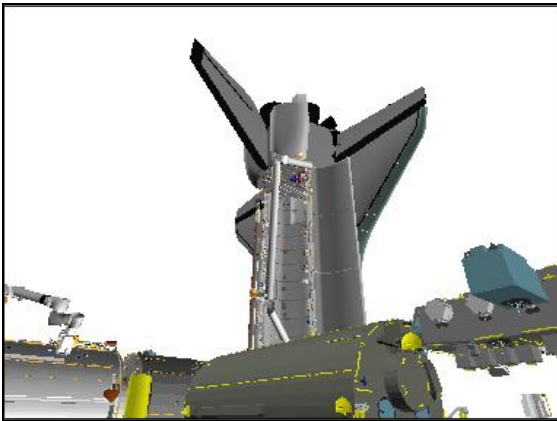

P1 LOOB (130,30)

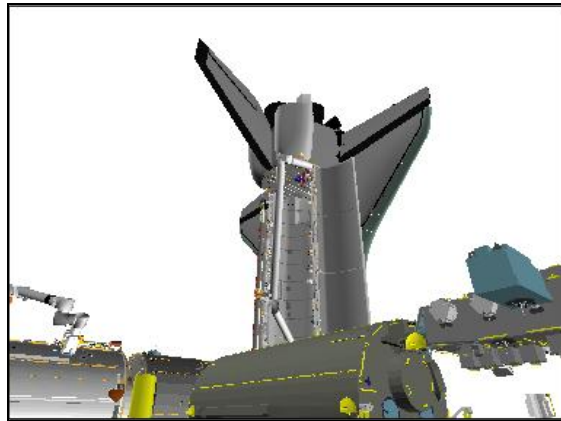

P1 LOOB (130,30)

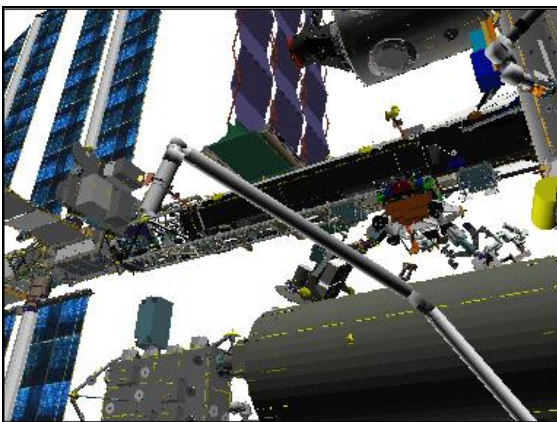

CCTV B (-30,30)

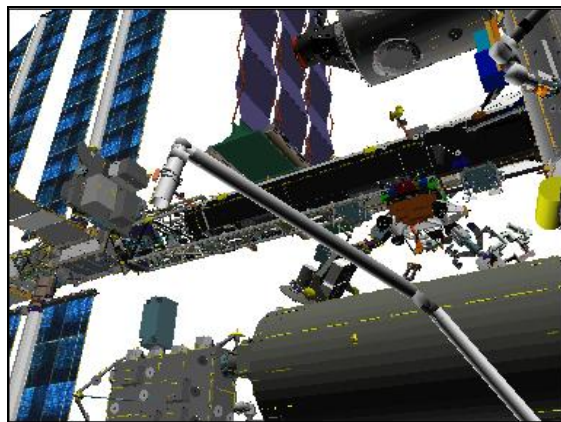

CCTV B (-30,30)

Step 6:

Drive WR- (for 131.2°)
From +32.2 to -99.0

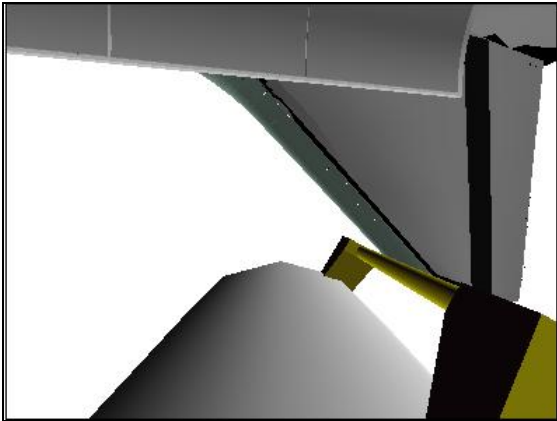

EE

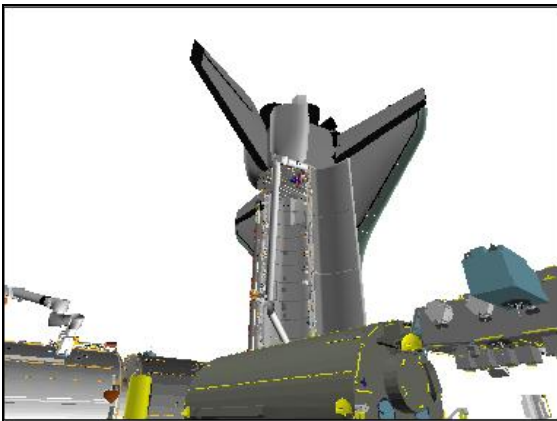

P1 LOOB (130,30)

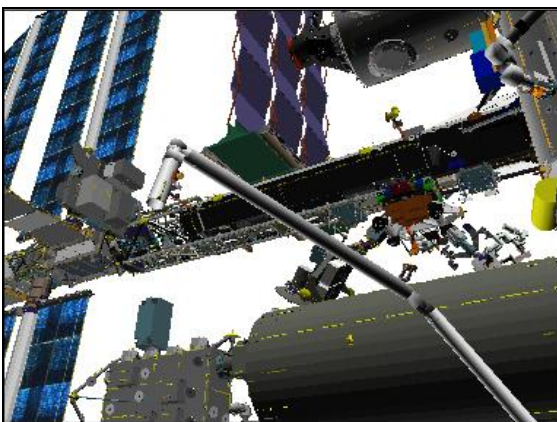

CCTV B (-30,30)

3. CONFIGURE POWER

CAUTION
SPEE power must be applied within 90 min
to prevent sensor package damage

On SSRMS Operator GO to release stbd MRLs,
STBD RMS HTR A,B (two) – OFF

A6U EVENT TIMER MODE – UP
 CNTL – START

MA73C:C cb MCA PWR AC3 3Φ MID 2 – op
 √AC2 3Φ MID 2 – op

MA73C:D √AC3 3Φ MID 4 – op

R13L PL BAY MECH PWR SYS (two) – ON

4. STBD MRL RELEASE

SM 94 PDRS CONTROL

RMS STBD – ITEM 2 EXEC (*)
√STBD AFT, MID, FWD REL (six) = 0

NOTE
Expect single motor drive time for MRL release

STBD RMS RETEN LAT – REL (tb-REL) (18 sec max)
– OFF
If motor drive time > 18 sec, √MCC

SM 94 PDRS CONTROL

√STBD AFT, MID, FWD REL (six) = 1

5. RECONFIGURE POWER

R13L PL BAY MECH PWR SYS (two) – OFF

MA73C:C cb MCA PWR AC3 3Φ MID 2 – cl
 √AC2 3Φ MID 2 – op

MA73C:D √AC3 3Φ MID 4 – op

Give SSRMS Operator GO for OBSS Unberth and SSRMS mnvr to Handoff

Monitor RFL Status

After OBSS Unberth,
style="text-align: center;">SM 94 PDRS CONTROL
RMS PORT – ITEM 1 EXEC (*)

A7U 6. SETUP FOR GRAPPLE
 CCTV – configure for grapple
 – install OBSS SJ GRAPPLE AT HANDOFF OVERLAY
 – RMS WRIST, ZOOM: 34.0 HFOV
 FOCUS: 5 ft
 Maintain eyepoint approx 18 in when using grapple overlay

R12(OBSS) ✓SPEE PWR – OFF

L12(SSP 1) ✓APCU 2 OUTPUT RLY – OP (tb-bp)

RHC 7. OBSS SJ GRAPPLE AT HANDOFF POSN
 On SSRMS Operator GO for SRMS OBSS grapple,







If SINGLE mode available:
 RATE – VERN (RATE MIN tb-ON)
 BRAKES – OFF (tb-OFF)

MODE – best available

Drive joints per OBSS SJ GRAPPLE AT HANDOFF OVERLAY and diagram until EE within grapple envelope

CAUTION
 Monitor EE tb timing to prevent EE motor burnout

EE MODE – AUTO
 CAPTURE sw – depress (mom)

✓	RIGID 	CLOSE 	CAPTURE 	<u>CRITICAL TIMES (28 sec total):</u> CAPTURE tb – gray, then CLOSE tb – gray, 3 sec max, then RIGID tb – gray, 25 sec max
	DERIGID 	OPEN 	EXTEND 	

EE MODE – OFF

- * If manual capture required: *
- * EE MODE – MAN *
- * CAPTURE sw – depress (hold until CLOSE tb-gray, 3 sec max) *
- * MAN CONTR – RIGID (hold until RIGID tb-gray, 25 sec max) *
- * MODE – OFF *

If TEST mode available,
 MODE – TEST, ENTER
 Wait 5 sec

BRAKES – ON (tb-ON)
 MODE – not DIRECT (It off)

PARAM – PORT TEMP
 JOINT – CRIT TEMP

OBSS SJ GRAPPLE AT HANDOFF

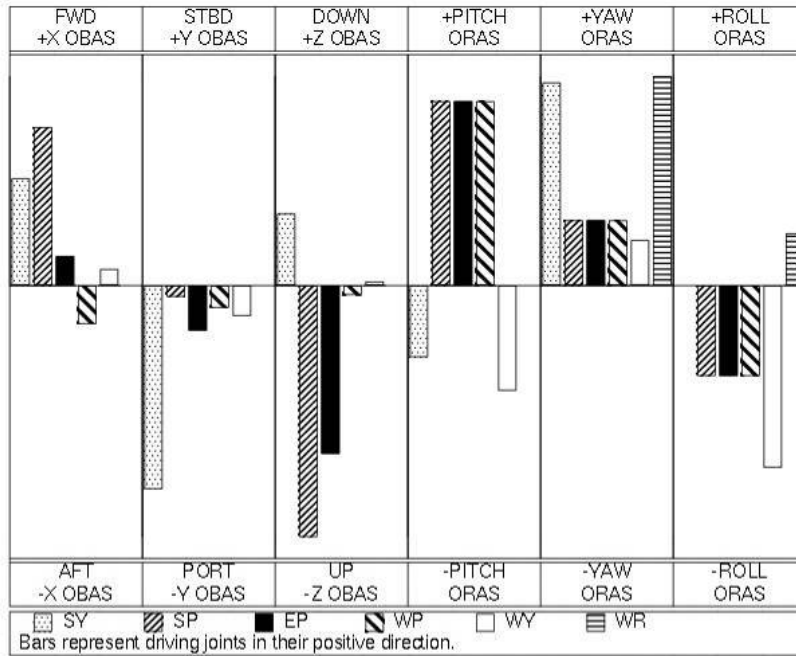

To get:	Drive:	To get:	Drive:	Driving:	Results In:	Driving:	Results In:
+X (fwd)	+SP, +SY	+PITCH	+WP, +EP	+SY	-Y (port), +YAW	+WP	-X (aft), +PITCH
+Y (stbd)	-SY	+YAW	+WR, +SY	+SP	-Z (up), +PITCH	+WY	-Y (port), -ROLL
+Z (down)	-SP, -EP	+ROLL	-WY, -WP	+EP	-Z (up), +PITCH	+WR	+YAW

ΔSY	ΔSP	ΔEP	ΔWP	ΔWY	ΔWR
+1.8	+1.5	-14.6	+13.5	-0.6	-1.7

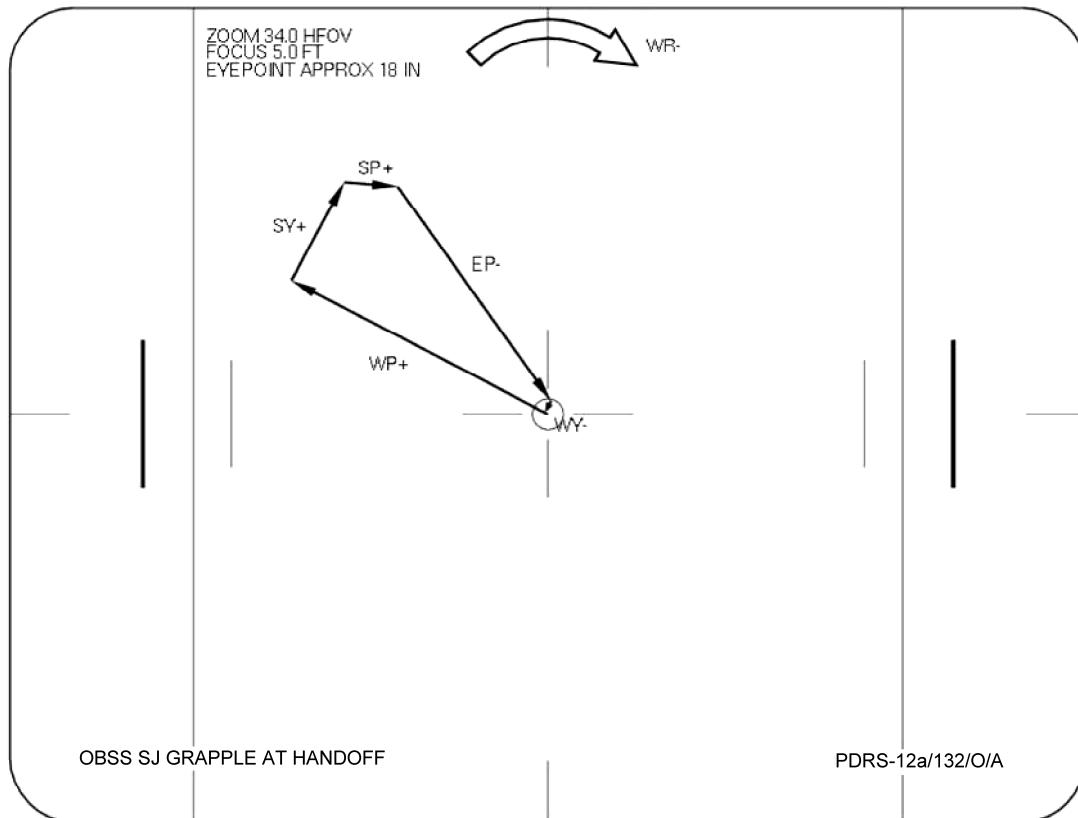

SM 94 PDRS CONTROL

PL ID – ITEM 3 +2 EXEC

INIT ID – ITEM 24 +2 EXEC

Expected OBSS HANDOFF posn:

	X	Y	Z	PITCH	YAW	ROLL	PL ID
							2
√	-1029	+229	-614	14	270	0	2
	SY	SP	EP	WP	WY	WR	
√	+25.8	+66.3	-49.0	-85.9	+10.7	-100.7	

*Display singularity

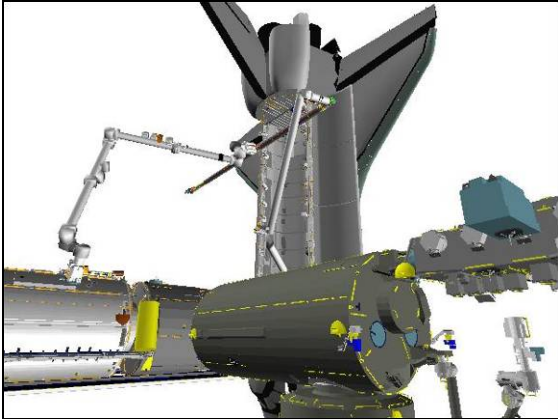

P1 LOOB (130,20)

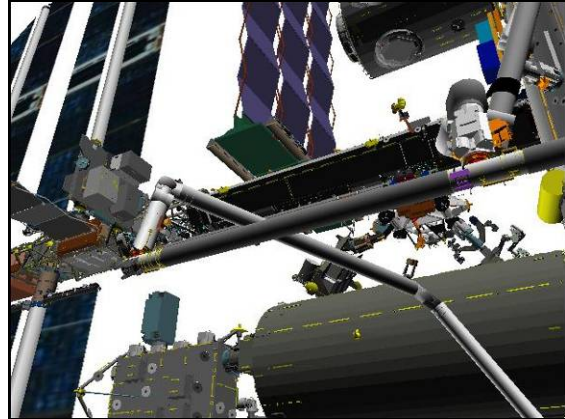

CCTV B (-30,30)

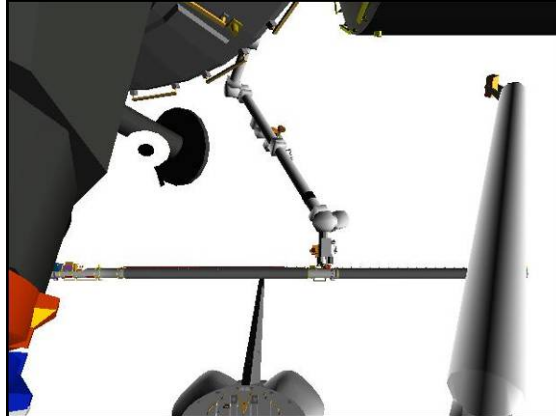

CCTV A (0,30)

R12 Green Jumper – LDRI/ITVC

Perform ACTIVATION (LDRI/ITVC Cue Card, PHOTO/TV)

Perform LCH ACTIVATION (LCS Cue Card, PHOTO/TV)

Give SSRMS Operator GO for OBSS ungrapple

Perform LCC ACTIVATION (LCS Cue Card, PHOTO/TV)

Perform LCC DEACTIVATION (LCS Cue Card, PHOTO/TV), steps 1 and 2

R12 Green Jumper – ISS

Review GENERIC END EFFECTOR CUE CARD – ISS/SHUTTLE DOCKED OPS

OBSS HANDBACK TO SSRMS

1. SETUP

V10/L	A
V10/R	P1 LOOB
MON 1	B (C)
MON 2	Elbow (EE)

SM 94 PDRS CONTROL

√PL ID, ITEM 3: 2

√INIT ID, ITEM 24: 2

Verify SRMS at OBSS HANDOFF posn:

X	Y	Z	PITCH	YAW	ROLL	PL ID
-1029	+229	-614	14	270	0	2
SY	SP	EP	WP	WY	WR	
+25.8	+66.3	-49.0	-85.9	+10.7	-100.7	

*Display singularity

√BRAKES – ON (tb-ON)

Notify SSRMS Operator SRMS at OBSS Handoff with Brakes On,
GO for SSRMS OBSS grapple

Review GENERIC END EFFECTOR CUE CARD – ISS/SHUTTLE DOCKED OPS

2. STOW PTU

R12(VPU) Green Jumper – LDRI/ITVC

A7U DTV ← PL2

CAMR CMD PAN/TILT – HI RATE
PAN – L (to hard stop)
TILT – UP (to hard stop)
PAN/TILT – RESET
PAN: +108 (right)
TILT: -175 (down)

R12(VPU) Green Jumper – ISS

On SSRMS Operator GO for SRMS OBSS ungrapple,

<p style="text-align: center;">CAUTION</p> <p>STBD RMS HTR power must be applied within 90 min to prevent sensor package damage</p>
--

Perform LCC DEACTIVATION (LCS Cue Card, PHOTO/TV)
Perform LCH DEACTIVATION (LCS Cue Card, PHOTO/TV)
Perform DEACTIVATION (LDRI/ITVC Cue Card, PHOTO/TV)

A7U 3. OBSS UNGRAPPLE
 CCTV – configure for ungrapple
 – RMS WRIST, ZOOM: 34.0 HFOV
 FOCUS: 5 ft

NOTE

CONTRL ERR It and 'S96 PDRS CNTL' msg may occur due to Consistency/Envelope Check error

RHC RATE – COARSE (RATE MIN tb-OFF)

SM 94 PDRS CONTROL

AUTO BRAKE INH – ITEM 10 EXEC (*)

BRAKES – OFF (tb-OFF)
 MODE – TEST, ENTER
 Wait 5 sec

BRAKES – ON (tb-ON)

SM 94 PDRS CONTROL

AUTO BRAKE ENA – ITEM 9 EXEC (*)

PL ID – ITEM 3 +0 EXEC
 INIT ID – ITEM 24 +0 EXEC

RHC RATE – VERN (RATE MIN tb-ON)
 BRAKES – OFF (tb-OFF)
 MODE – END EFF, ENTER

CAUTION
 Monitor EE tb timing to prevent EE motor burnout

EE MODE – AUTO
 RELEASE sw – depress (mom)

When OPEN tb – gray, mnvr arm clear of grapple pin

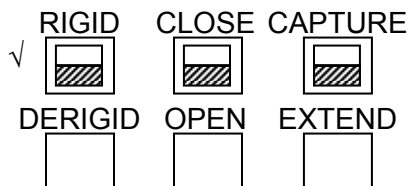

CRITICAL TIMES (28 sec total):
 DERIGID tb – gray, 5 sec max, then
 OPEN tb – gray, 3 sec max, then
 EXTEND tb – gray, 20 sec max

EE MODE – OFF

- * If manual release reqd: *
- * EE MODE – MAN *
- * MAN CONTR – DERIGID (hold until DERIGID tb-gray, 5 sec max) *
- * RELEASE sw – depress (hold until OPEN tb-gray, 3 sec max) *
- * Mnvr arm clear of grapple pin, then *
- * EE MAN CONTR – DERIGID (hold until EXTEND tb-gray, 20 sec max) *
- * MODE – OFF *

Mnvr to OBSS BACKOFF posn:

X	Y	Z	PITCH	YAW	ROLL	PL ID
-1018	-362	-676	284	0	270	0
SY	SP	EP	WP	WY	WR	
+24.0	+64.8	-34.4	-99.4	+11.3	-99.0	

BRAKES – ON (tb-ON)

- * If Orbiter Attitude Control: ROBOTICS ATTITUDE MAINTENANCE *
- * (ORB OPS, REBOOST/DAP) steps 1,2 *

Notify SSRMS Operator SRMS at OBSS Backoff with Brakes On,
GO for SSRMS OBSS Berth

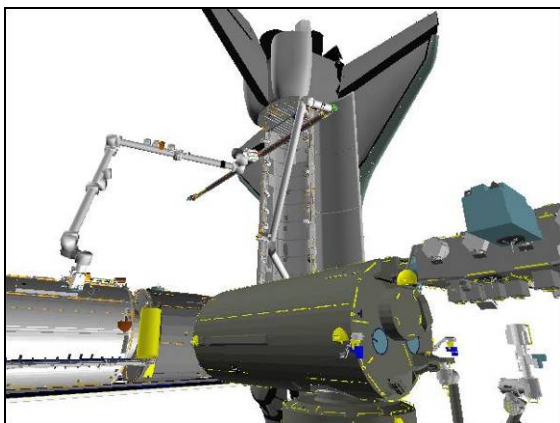

P1 LOOB (130,20)

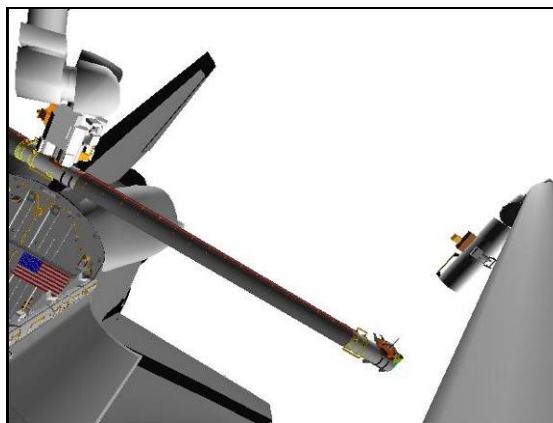

ELBOW (-35,-10)

4. CONFIGURE CIRCUIT BREAKERS
 MA73C:C cb MCA PWR AC3 3Φ MID 2 – op
 √AC2 3Φ MID 2 – op
 MA73C:D √AC3 3Φ MID 4 – op

5. CONFIGURE FOR MONITORING
 On SSRMS Operator notification to watch for stbd RMS RFLs,
SM 94 PDRS CONTROL
 RMS STBD – ITEM 2 EXEC (*)

Notify SSRMS Operator when STBD RMS R-F-L tb (three) – gray

6. STBD MRL LATCH
 On SSRMS Operator GO to latch stbd MRLs to Topological Capture,
 √STBD RMS R-F-L tb (three) – gray
SM 94 PDRS CONTROL
 √STBD AFT, MID, FWD LAT (six) = 0

- R13L Verify AOS for latching to Topological Capture
 PL BAY MECH PWR SYS (two) – ON

NOTE

Expect single motor drive time for MRL latching (18 sec max).
The following STBD RMS RETEN LAT – OFF and PL BAY
MECH PWR SYS (two) – OFF actions are to be performed simo

STBD RMS RETEN LAT – LAT 6 sec only (tb-bp)
– OFF

R13L PL BAY MECH PWR SYS (two) – OFF

Give SSRMS Operator GO to Limp All SSRMS Joints and Derigidize

R13L On SSRMS Operator GO to complete stbd MRL latching,
PL BAY MECH PWR SYS (two) – ON

STBD RMS RETEN LAT – LAT (tb-LAT) (12 sec max)
– OFF

7. RECONFIGURE POWER

R13L PL BAY MECH PWR SYS (two) – OFF

STBD RMS HTR A,B (two) – AUTO

A6U EVENT TIMER CNTL – STOP

SM 94 PDRS CONTROL

√STBD AFT, MID, FWD LAT (six) = 1
RMS PORT – ITEM 1 EXEC (*)

MA73C:C cb MCA PWR AC3 3Φ MID 2 – cl

√AC2 3Φ MID 2 – op

MA73C:D √AC3 3Φ MID 4 – op

Give SSRMS Operator GO for OBSS ungrapple

BATTERY R&R VIEWING TO OBSS SENSOR PROTECT

I

1. SETUP

NOTE

This procedure assumes 23S docking to SM Aft with SRMS starting position at Battery R&R Viewing

V10/L	Elbow
V10/R	P1 LOOB (RSC)
MON 1	A
MON 2	B

- RHC
- MNVR TO OBSS SENSOR PROTECT
 RATE – as reqd (VERN within 10 ft)
 BRAKES – OFF (tb-OFF)
 MODE – SINGLE, ENTER

Mnvr to OBSS SENSOR PROTECT posn:

	SY	SP	EP	WP	WY	WR	
Battery View	+30.0	+20.0	-25.0	+5.0	-10.0	+100.0	
1: SY +	+70.0						
2: SP +		+25.0					
3: EP –			-45.0				
4: WP –				-80.0			
5: WY +					+35.0		
6: WR –						-90.0	
Snsr Protect	+70.0	+25.0	-45.0	-80.0	+35.0	-90.0	
	X	Y	Z	PITCH	YAW	ROLL	PL ID
	-1154	-64	-107	339	308	20	2

BRAKES – ON (tb-ON)
 √MODE – not DIRECT (lt off)

PARAM – PORT TEMP
 JOINT – CRIT TEMP

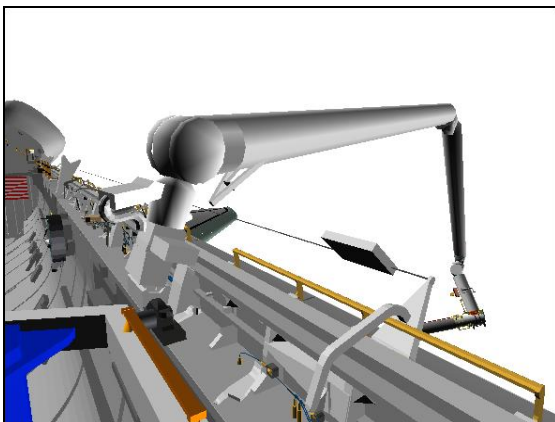

CCTV A (35,-10)

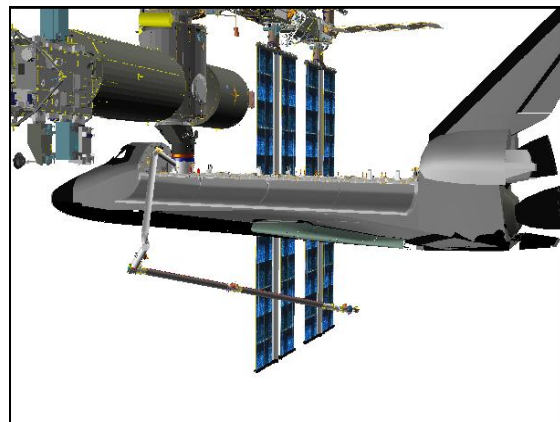

BIRD'S EYE

3. STOW CAMERAS

R12(VPU) √Green Jumper – LDRI/ITVC
A7U DNLK ← PL2
PAN: +100
TILT: -60

√PORT RMS CAMR – ELBOW

DNLK ← RMS
PAN: -20
TILT: -10

OBSS SENSOR PROTECT TO BATTERY R&R VIEWING

I

1. SETUP

NOTE

This procedure assumes 23S docking to SM Aft with SRMS at OBSS Sensor Protect posn

V10/L	Elbow
V10/R	P1 LOOB
MON 1	A
MON 2	B

- RHC
- MNVR TO OBSS SENSOR PROTECT
 RATE – as reqd (VERN within 10 ft)
 BRAKES – OFF (tb-OFF)
 MODE – SINGLE, ENTER

Mnvr to BATTERY VIEWING posn:

	SY	SP	EP	WP	WY	WR	
Snsr Protect	+70.0	+25.0	-45.0	-80.0	+35.0	-90.0	
1: WR +						+100.0	
2: WY –					-10.0		
3: WP +				+5.0			
4: EP +			-25.0				
5: SP –		+20.0					
6: SY –	+30.0						
Battery View	+30.0	+20.0	-25.0	+5.0	-10.0	+100.0	
	X	Y	Z	PITCH	YAW	ROLL	PL ID
	-998	-949	-321	203	68	242	2

- BRAKES – ON (tb-ON)
 √MODE – not DIRECT (lt off)

PARAM – PORT TEMP
 JOINT – CRIT TEMP

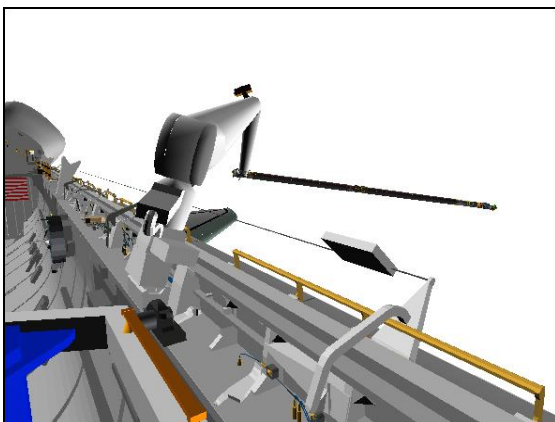

CCTV A (35,-10)

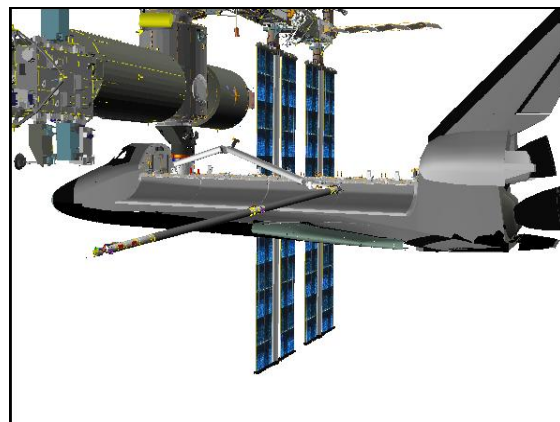

BIRD'S EYE

This Page Intentionally Blank

REFERENCE DATA

MRM1 JOINT ANGLES VS POR COORDINATES	FS 6-2
COORDINATE SYSTEM – PL ID 3.....	FS 6-4
PRLA CONFIGURATION	FS 6-5
OBSS JOINT ANGLES VS POR COORDINATES	FS 6-6
VIEWING JOINT ANGLES VS POR COORDINATES	FS 6-7

**REFERENCE
DATA**

MRM1 JOINT ANGLES VS POR COORDINATES

MRM1 INTERMEDIATE PRE-GRAPPLE

X	Y	Z	PITCH	YAW	ROLL	PL ID
-1098	-408	-705	357	72	74	0
SY	SP	EP	WP	WY	WR	
+20.0	+50.0	-23.0	0.0	+48.0	+64.0	

MRM1 PRE-GRAPPLE

X	Y	Z	PITCH	YAW	ROLL	PL ID
-1141	0	-525	310	0	0	0
SY	SP	EP	WP	WY	WR	
-18.5	+47.6	-66.9	-34.4	+26.6	+22.1	

MRM1 GRAPPLE/BERTH

X	Y	Z	PITCH	YAW	ROLL	PL ID
-1187	0	-470	310	0	0	0
-1116	0	-414	0	0	0	3
SY	SP	EP	WP	WY	WR	
-14.8	+33.1	-53.1	-32.4	+24.3	+19.3	

MRM1 LOW HOVER

X	Y	Z	PITCH	YAW	ROLL	PL ID
-1187	0	-510	310	0	0	0
-1116	0	-454	0	0	0	3
SY	SP	EP	WP	WY	WR	
-16.3	+35.2	-48.7	-39.4	+25.2	+20.6	

MRM1 HANDOFF

X	Y	Z	PITCH	YAW	ROLL	PL ID
-1116	0	-656	310	0	0	0
-1045	0	-600	0	0	0	3
SY	SP	EP	WP	WY	WR	
-25.0	+53.4	-50.3	-59.7	+30.2	+28.6	

MRM1 BACKOFF

X	Y	Z	PITCH	YAW	ROLL	PL ID
-1077	0	-702	310	0	0	0
SY	SP	EP	WP	WY	WR	
-29.2	+59.9	-51.2	-67.6	+32.4	+32.2	

MRM1 CLEARANCE

X	Y	Z	PITCH	YAW	ROLL	PL ID
-1081	-345	-580	284	22	42	0
SY	SP	EP	WP	WY	WR	
+20.0	+59.9	-51.2	-67.6	+32.4	+32.2	

MRM1 INTERMEDIATE DOCK VIEWING

X	Y	Z	PITCH	YAW	ROLL	PL ID
-1030	-367	-697	125	41	340	0
SY	SP	EP	WP	WY	WR	
+20.0	+59.9	-51.2	+100.0	+32.4	+32.2	

MRM1 DOCK VIEWING

X	Y	Z	PITCH	YAW	ROLL	PL ID
-870	-465	-777	107	329	279	0
SY	SP	EP	WP	WY	WR	
+52.6	+58.4	-20.3	+103.3	-15.0	-3.4	

MRM1 PROBE REMOVAL BACKOFF

X	Y	Z	PITCH	YAW	ROLL	PL ID
-1012	-45	-665	270	335	270	0
-1012	-128	-629	270	285	270	3
SY	SP	EP	WP	WY	WR	
-21.0	+73.2	-70.0	-91.3	-5.2	-48.9	

MRM1 PROBE REMOVAL

X	Y	Z	PITCH	YAW	ROLL	PL ID
-1012	+13	-590	270	335	270	0
-1012	-70	-554	270	285	270	3
SY	SP	EP	WP	WY	WR	
-25.3	+68.9	-83.0	-73.5	-5.0	-44.6	

MRM1 COORDINATE SYSTEM – PL ID 3

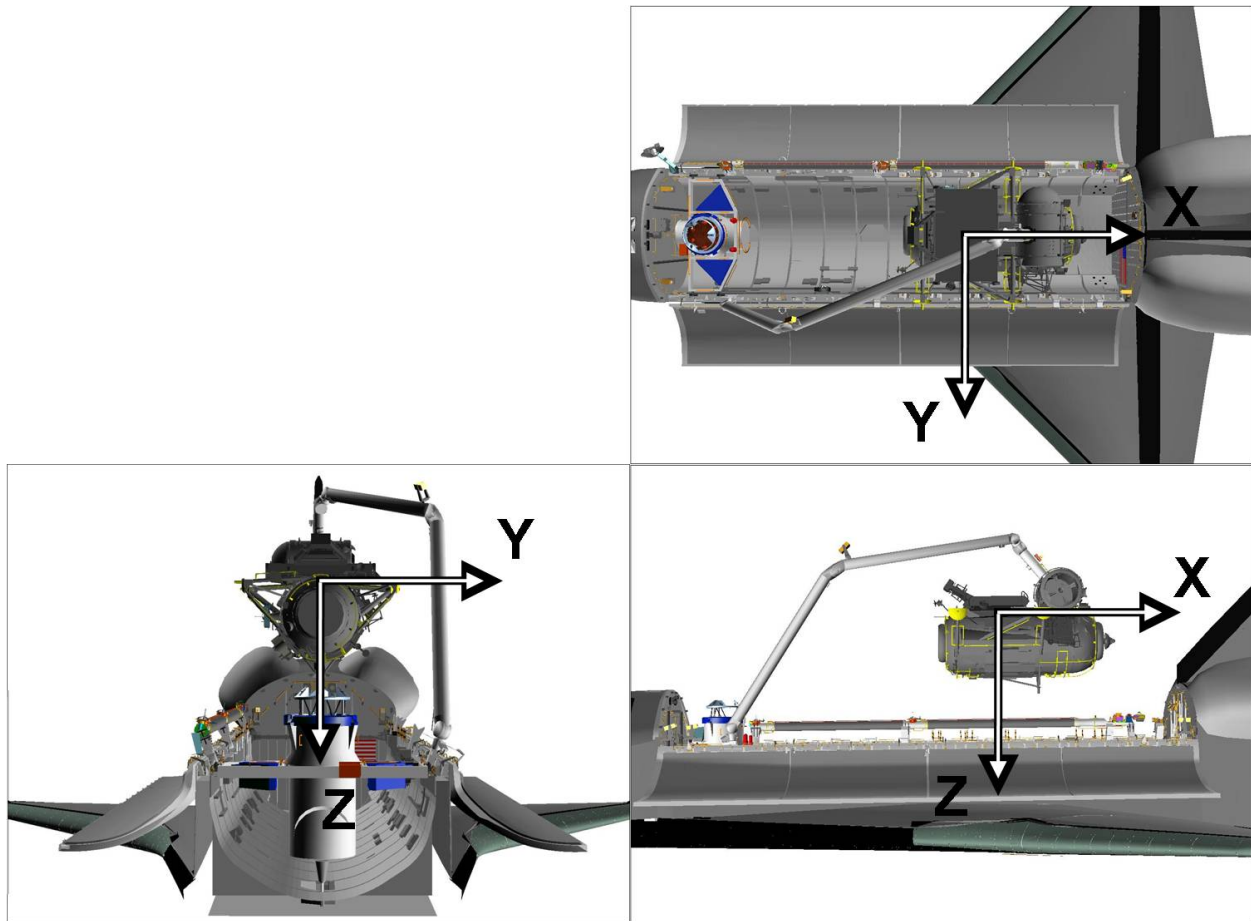

POR: Centered at trunnion level, aligned with ORAS

PURPOSE: MRM1 Handoff

RATES:	<u>COARSE</u>	<u>VERN</u>
TRANS LIM ft/sec	0.21	0.10
ROT LIM deg/sec	0.74	0.25

JOINT RATES:	<u>COARSE</u>	<u>VERN</u>
SHOULDER LIM deg/sec	0.36	0.12
ELBOW LIM deg/sec	0.50	0.17
WRIST LIM deg/sec	0.74	0.25

MRM1 PRLA CONFIGURATION

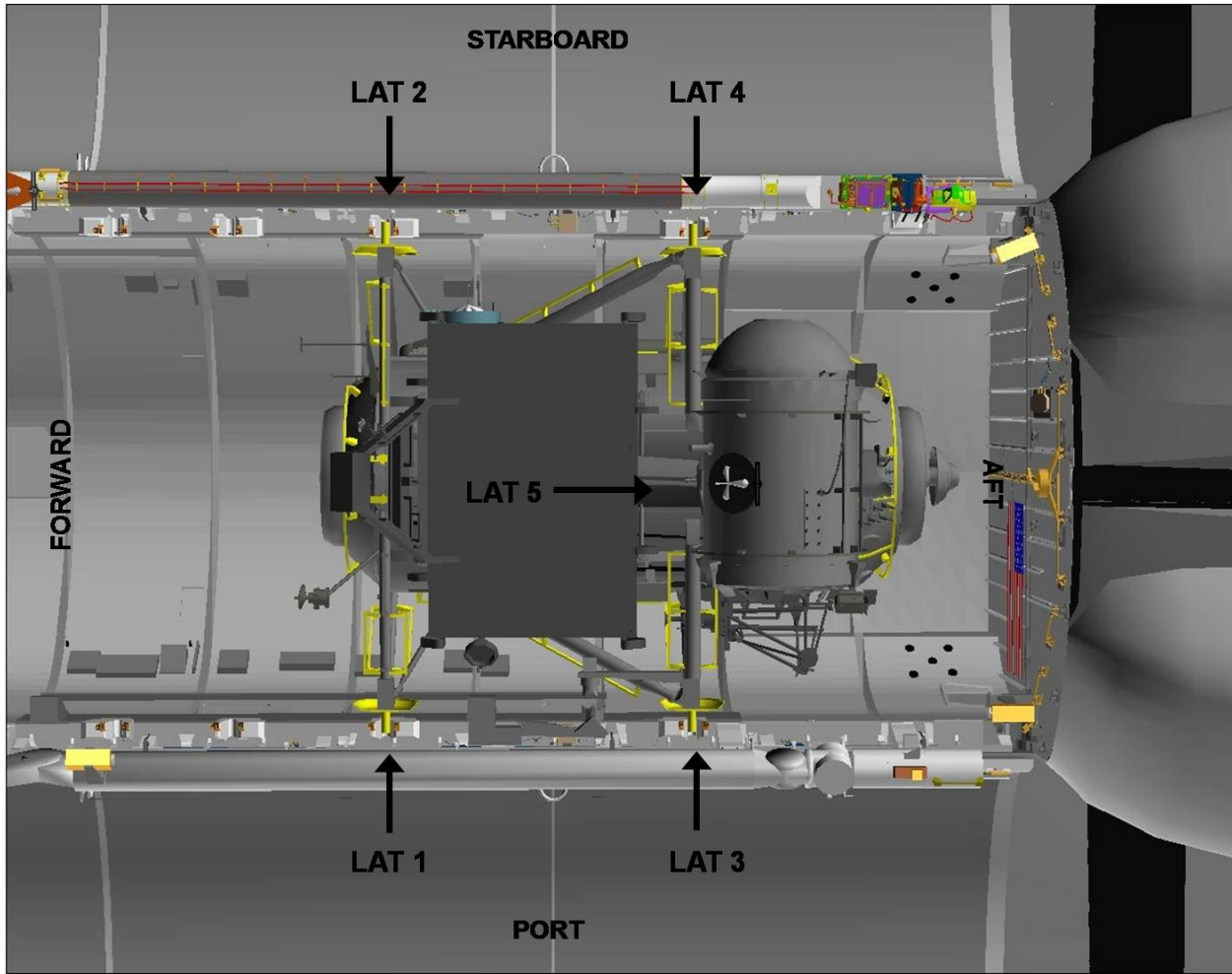

SEQUENCE	PL SEL	RELEASE
AKA	3	5
PRLA	3	1,2 (Forward)
PRLA	3	3,4 (Aft)

OBSS JOINT ANGLES VS POR COORDINATES

OBSS HANDOFF PRE-GRAPPLE/OBSS BACKOFF

X	Y	Z	PITCH	YAW	ROLL	PL ID
-1018	-362	-676	284	0	270	0
-1015	+229	-673	284	270	270	2
SY	SP	EP	WP	WY	WR	
+24.0	+64.8	-34.4	-99.4	+11.3	-99.0	

*Display singularity

OBSS HANDOFF/UNDOCK

X	Y	Z	PITCH	YAW	ROLL	PL ID
-1032	-362	-618	284	0	270	0
-1041	-362	-602	14	270	0	1
-1029	+229	-614	14	270	0	2
SY	SP	EP	WP	WY	WR	
+25.8	+66.3	-49.0	-85.9	+10.7	-100.7	

*Display singularity

AUTO SEQUENCE TO FLAT FIELDS

Auto Pos #	X/ SY	Y/ SP	Z/ EP	PITCH/ WP	YAW/ WY	ROLL/ WR	PL ID
148	-1029	+229	-614	14	270	0	2
	+26.1	+67.7	-51.2	-85.0	+10.6	-100.6	
149	-800	+500	-250	281	333	95	2
	-86.7	+72.7	-86.0	+21.2	-3.3	-169.3	
150	-1130	+350	-400	325	336	30	2
	-80.4	+90.4	-94.6	-76.3	-43.9	-262.8	
151	-1270	+350	-445	0	0	11	2
	-90.1	+25.0	-65.8	-57.6	0.0	-249.9	

HANDOFF LOW

X	Y	Z	PITCH	YAW	ROLL	PL ID
-1086	-338	-472	267	351	265	0
-1036	+243	-563	119	280	121	2
SY	SP	EP	WP	WY	WR	
+25.8	+47.0	-49.0	-85.9	+10.7	-100.7	

OBSS SENSOR PROTECT

X	Y	Z	PITCH	YAW	ROLL	PL ID
-814	-528	-241	233	348	307	0
-1154	-64	-107	339	308	20	2
SY	SP	EP	WP	WY	WR	
+70.0	+25.0	-45.0	-80.0	+35.0	-90.0	

VIEWING JOINT ANGLES VS POR COORDINATES

ICC UNBERTH VIEWING

X	Y	Z	PITCH	YAW	ROLL	PL ID
-1233	-319	-436	353	19	1	0
-1305	-327	-1023	83	1	341	2
SY	SP	EP	WP	WY	WR	
+20.0	+20.0	-25.0	+5.0	0.0	0.0	

SGANT & EOTP VIEWING

X	Y	Z	PITCH	YAW	ROLL	PL ID
-820	-493	-764	159	7	0	0
SY	SP	EP	WP	WY	WR	
+53.0	+62.0	-23.0	+107.0	+48.0	+64.0	

BATTERY R&R VIEWING

X	Y	Z	PITCH	YAW	ROLL	PL ID
-1194	-398	-408	353	19	101	0
-998	-949	-321	203	68	242	2
SY	SP	EP	WP	WY	WR	
+30.0	+20.0	-25.0	+5.0	-10.0	+100.0	

This Page Intentionally Blank

CUE CARD CONFIGURATION

OVERLAY FOR ROEU PL SEL POSITION.....	FS CC 7-2
SJ MRM1 GRAPPLE – CCTV OVERLAY	FS CC 7-3
RELEASE AT HANDOFF – CCTV OVERLAY	FS CC 7-4
OBSS SJ GRAPPLE AT HANDOFF	FS CC 7-5

CUE CARD
CONFIG

CUE CARD
CONFIG

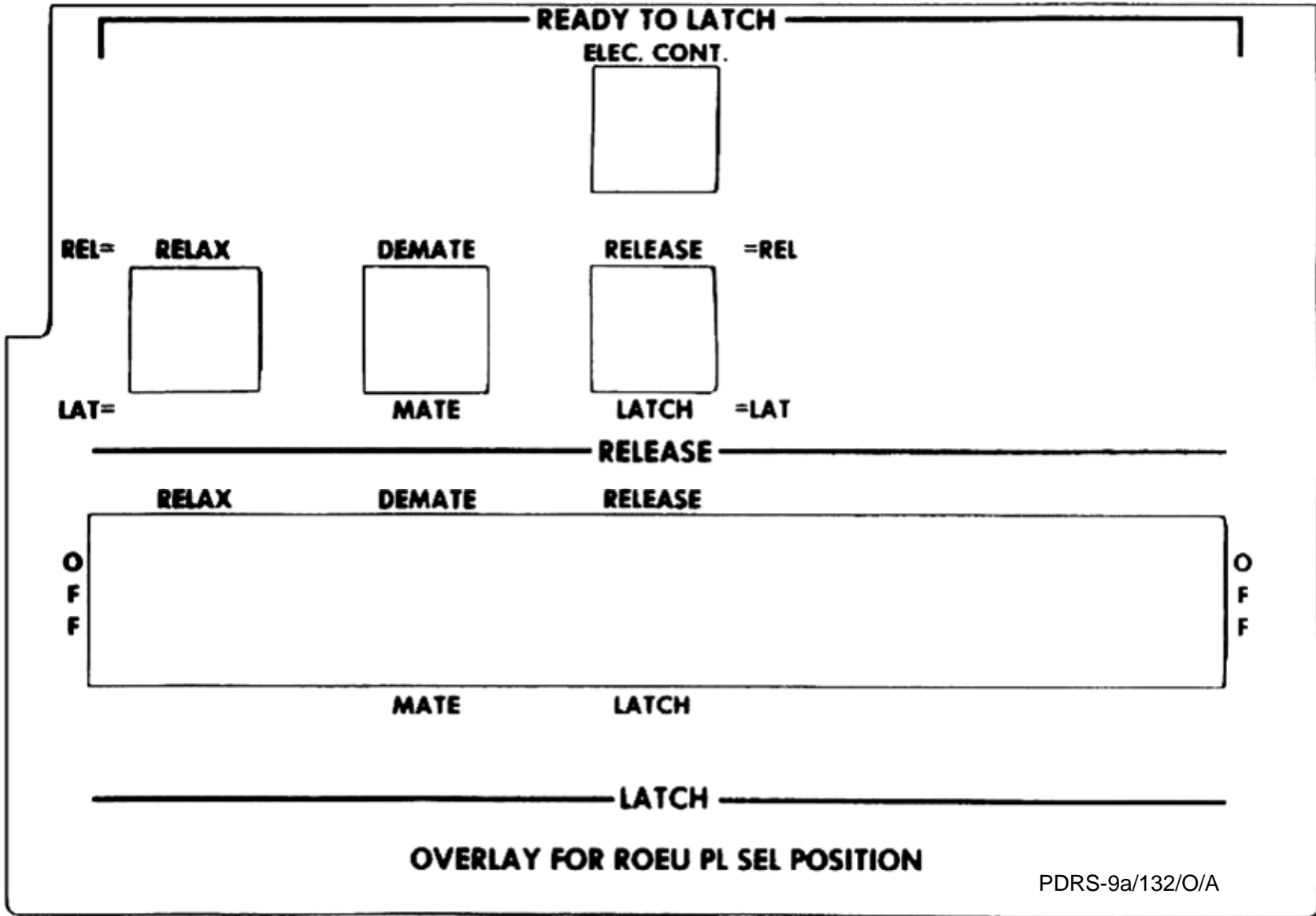

(reduced copy)

FS CC 7-2

PDRS/132/FIN

Fabricate as transparency

ZOOM 34.0 HFOV
FOCUS 5.0 FT
EYEPOINT APPROX 18 IN



STBD

PORT

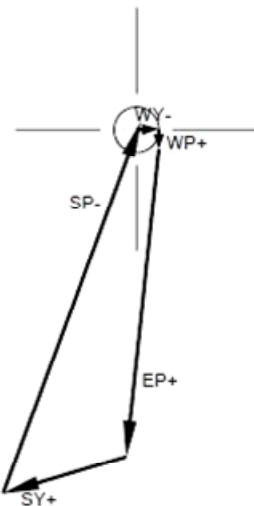

DOWN/FWD

SJ MRM1 GRAPPLE - CCTV OVERLAY

PDRS-10a/132/O/A

(reduced copy)

FS CC 7-3

PDRS/132/FIN

Fabricate as transparency

ZOOM 34.0 HFOV
FOCUS 5.0 FT
EYEPOINT APPROX 18 IN

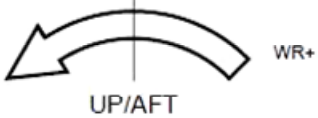

STBD

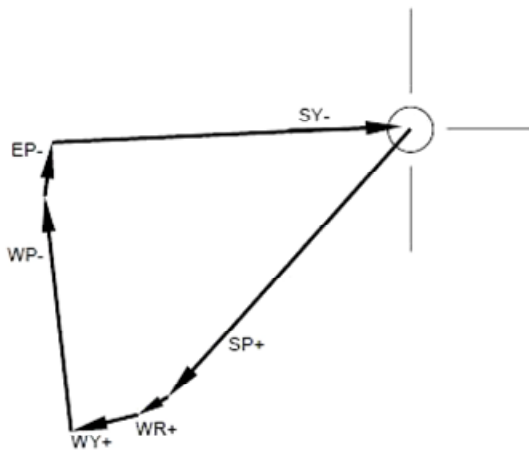

PORT

SJ MRM1 RELEASE AT HANDOFF – CCTV OVERLAY
DOWN/FWD

PDRS-11a/132/O/A

(reduced copy)

FS CC 7-4

PDRS/132/FIN

Fabricate as transparency

ZOOM 34.0 HFOV
FOCUS 5.0 FT
EYEPOINT APPROX 18 IN



WR-

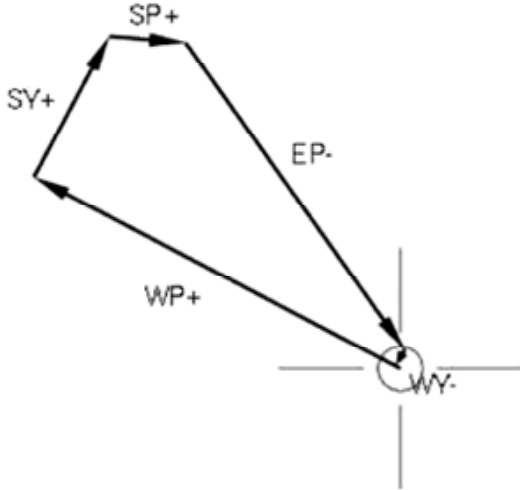

OBSS SJ GRAPPLE AT HANDOFF

PDRS-12a/132/O/A

(reduced copy)

FS CC 7-5

PDRS/132/FIN

This Page Intentionally Blank



PDRS OPS C/L

**STS
132**