

PDRS Operations Checklist

STS-400 Flight Supplement

**Mission Operations Directorate
EVA, Robotics, & Crew Systems
Operations Division**

**Final, Rev A
October 15, 2008**

National Aeronautics and
Space Administration

Lyndon B. Johnson Space Center
Houston, Texas

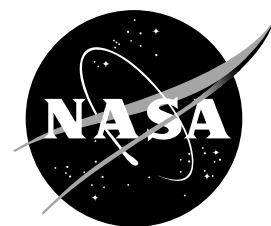

MISSION OPERATIONS DIRECTORATE

**PDRS OPERATIONS CHECKLIST
STS-400 FLIGHT SUPPLEMENT**

FINAL, REVISION A
October 15, 2008

PREPARED BY:

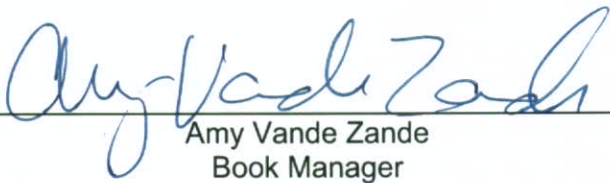

Amy Vande Zande
Book Manager

APPROVED BY:

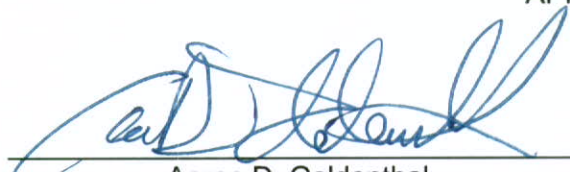

Aaron D. Goldenthal
Lead, Shuttle and Exploration Robotics
Operations Group

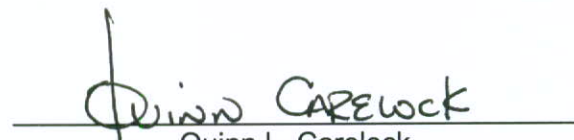

Quinn L. Carelock
Chief, Robotics Operations Branch

This document is under the configuration control of the Crew Procedures Control Board (CPCB). All proposed changes must be submitted via FDF Workflow Crew Procedure Change Request (CR) to DO3/FDF Manager.

Additional distribution of this book, for official use only, may be requested in writing to DO3/PMO Administrator. The request must include justification and requester's name, organization, position, and phone number. Contractor requests are made through the NASA or DOD organization supported. Deletions, reduction in quantity, or change of address may be submitted to DO3/FDF Management Office, 281-244-1184.

Incorporates the following:	
482#:	PDRS_FS-0094 PDRS_FS-0095 PDRS_FS-0096 PDRS_FS-0097 PDRS_FS-0098

AREAS OF TECHNICAL RESPONSIBILITY

Book Manager

DX22/A. Vande Zande

281-483-7550

PDRS OPERATIONS CHECKLIST
 STS-400 FLIGHT SUPPLEMENT

LIST OF EFFECTIVE PAGES

FINAL 08/01/08
 REV A 10/15/08

Sign Off.....	*	400/FIN A	FS 2-28.....	⊗	400/FIN A
FS ii.....	*	400/FIN A	FS 2-29.....		400/FIN A
FS iii.....	*	400/FIN A	FS 2-30.....	⊗	400/FIN A
FS iv.....	*	400/FIN A	FS 2-31.....	⊗	400/FIN A
FS v.....		400/FIN A	FS 2-32.....	⊗	400/FIN A
FS vi.....		400/FIN A	FS 2-33.....	⊗	400/FIN A
FS 1-1.....		400/FIN A	FS 2-34.....	⊗	400/FIN A
FS 1-2.....	⊗	400/FIN A	FS 3-1.....		400/FIN A
FS 1-3.....	⊗	400/FIN A	FS 3-2.....		400/FIN A
FS 1-4.....	⊗	400/FIN A	FS 3-3.....	⊗	400/FIN A
FS 1-5.....	⊗	400/FIN A	FS 3-4.....	⊗	400/FIN A
FS 1-6.....	⊗	400/FIN A	FS 3-5.....	⊗	400/FIN A
FS 1-7.....	⊗	400/FIN A	FS 3-6.....	⊗	400/FIN A
FS 1-8.....	⊗	400/FIN A	FS 3-7.....	⊗	400/FIN A
FS 1-9.....	⊗	400/FIN A	FS 3-8.....	⊗	400/FIN A
FS 1-10.....	⊗	400/FIN A	FS 3-9.....	⊗	400/FIN A
FS 1-11.....	⊗	400/FIN A	FS 3-10.....	⊗	400/FIN A
FS 1-12.....		400/FIN A	FS 3-11.....		400/FIN A
FS 2-1.....		400/FIN A	FS 3-12.....	⊗	400/FIN A
FS 2-2.....	⊗	400/FIN A	FS 3-13.....	⊗	400/FIN A
FS 2-3.....	⊗	400/FIN A	FS 3-14.....		400/FIN A
FS 2-4.....	⊗	400/FIN A	FS 3-15.....	⊗	400/FIN A
FS 2-5.....	⊗	400/FIN A	FS 3-16.....	⊗	400/FIN A
FS 2-6.....	⊗	400/FIN A	FS 3-17.....	⊗	400/FIN A
FS 2-7.....	⊗	400/FIN A	FS 3-18.....	⊗	400/FIN A
FS 2-8.....		400/FIN A	FS 3-19.....		400/FIN A
FS 2-9.....	⊗	400/FIN A	FS 3-20.....	⊗	400/FIN A
FS 2-10.....	⊗	400/FIN A	FS 3-21.....	⊗	400/FIN A
FS 2-11.....		400/FIN A	FS 3-22.....	⊗	400/FIN A
FS 2-12.....	⊗	400/FIN A	FS 4-1.....		400/FIN A
FS 2-13.....	⊗	400/FIN A	FS 4-2.....	⊗	400/FIN A
FS 2-14.....	⊗	400/FIN A	FS 4-3.....	⊗	400/FIN A
FS 2-15.....	⊗	400/FIN A	FS 4-4.....	⊗	400/FIN A
FS 2-16.....	⊗	400/FIN A	FS 4-5.....		400/FIN A
FS 2-17.....	⊗	400/FIN A	FS 4-6.....		400/FIN A
FS 2-18.....	⊗	400/FIN A	FS 4-7.....		400/FIN A
FS 2-19.....	⊗	400/FIN A	FS 4-8.....		400/FIN A
FS 2-20.....	⊗	400/FIN A	FS 4-9.....		400/FIN A
FS 2-21.....	⊗	400/FIN A	FS 4-10.....		400/FIN A
FS 2-22.....	⊗	400/FIN A	FS 4-11.....		400/FIN A
FS 2-23.....	⊗	400/FIN A	FS 4-12.....		400/FIN A
FS 2-24.....	⊗	400/FIN A	FS 4-13.....		400/FIN A
FS 2-25.....	⊗	400/FIN A	FS 4-14.....		400/FIN A
FS 2-26.....		400/FIN A	FS 5-1.....		400/FIN A
FS 2-27.....	⊗	400/FIN A	FS 5-2.....		400/FIN A

* – Omit from flight book

⊗ – Flight copies of this page contain color

FS CC 5-3.....	⊗ 400/FIN A	FS CC 5-7.....	400/FIN A
FS CC 5-4.....	⊗ 400/FIN A	FS CC 5-8.....	400/FIN A
FS CC 5-5.....	400/FIN A	FS CC 5-9.....	400/FIN A
FS CC 5-6.....	400/FIN A	FS 5-10.....	400/FIN A

PDRS CUE CARDS

<u>Title</u>	<u>Ref. Page</u>	<u>Card No.</u>
OBSS ITVC SCAN PATTERN CUE CARD – STBD BELLY TILE SURVEY (Front)	FS CC 5-3	PDRS-9a/400/O/A
OBSS ITVC SCAN PATTERN CUE CARD – PORT BELLY TILE SURVEY (Back)	FS CC 5-4	PDRS-9b/400/O/A
RMS SURVEY TIMELINE CUE CARD (Front)	FS CC 5-5	PDRS-10a/400/O/B
(Back).....	FS CC 5-6	PDRS-10b/400/O/A
STS-125 ORBITER SJ GRAPPLE WRIST CCTV	FS CC 5-7	PDRS-11a/400/O/A
STS-400 END EFFECTOR CUE CARD (Front)	FS CC 5-8	PDRS-13a/400/O/A
STS-400 JOINT SLIP RECOVERY CUE CARD (Back).....	FS CC 5-9	PDRS-13b/400/O/A

⊗ – Flight copies of this page contain color

<u>CONTENTS</u>	<u>PAGE</u>
<u>NOMINAL STS-125 OPS</u>	FS 1-1
POISED FOR CAPTURE POSITION.....	FS 1-2
STS-125 GRAPPLE	FS 1-4
ATTITUDE HOLD/EVA POSITION	FS 1-7
UNGRAPPLE	FS 1-9
<u>ORBITER SURVEY OPS</u>	FS 2-1
OBSS ITVC BELLY TILE SURVEY – STBD	FS 2-2
– PORT.....	FS 2-9
RMS EE CREW CABIN SURVEY.....	FS 2-27
<u>CONTINGENCY STS-125 OPS</u>	FS 3-1
SJ POISED FOR CAPTURE.....	FS 3-2
STS-125 GRAPPLE	FS 3-6
ATTITUDE HOLD/EVA POSITION	FS 3-13
MNVR TO PRE-CRADLE	FS 3-19
<u>STS-400 REFERENCE DATA</u>	FS 4-1
STS-125 PL ID/POR DEFINITION – PL ID 3.....	FS 4-2
ORBITER SURVEYS PL ID/POR DEFINITION – PL ID 5A.....	FS 4-3
5B (UPLINK)	FS 4-4
JOINT ANGLES VS POR COORDINATES	FS 4-5
STS-125 OPERATIONS.....	FS 4-5
ORBITER SURVEYS	FS 4-6
OBSS BELLY TILE SURVEY AUTOSEQUENCES	FS 4-7
CREW CABIN EE SURVEY AUTOSEQUENCES	FS 4-12
<u>CUE CARD CONFIGURATION</u>	FS 5-1

This Page Intentionally Blank

NOMINAL STS-125 OPS

POISED FOR CAPTURE POSITION	FS 1-2	I
STS-125 GRAPPLE	FS 1-4	
ATTITUDE HOLD/EVA POSITION	FS 1-7	
UNGRAPPLE	FS 1-9	

**NOMINAL
STS-125 OPS**

POISED FOR CAPTURE POSITION

NOMINAL
STS-125 OPS

1. SETUP

MON 1	A (D)
MON 2	C (B)

√	X	Y	Z	PITCH	YAW	ROLL	PL ID
	-1261	-146	-551	5	2	0	0
	SY	SP	EP	WP	WY	WR	
√	0.0	+25.0	-25.0	+5.0	0.0	0.0	

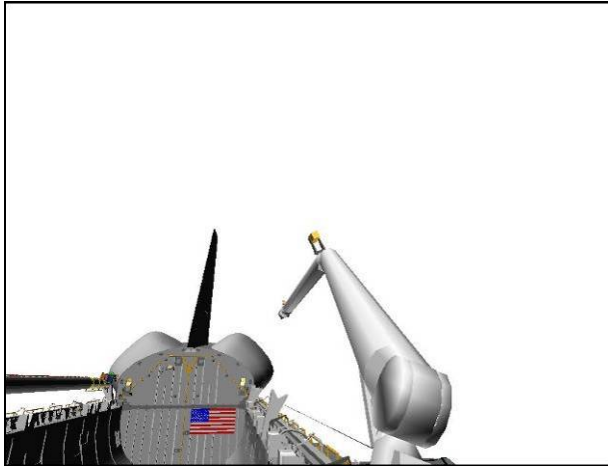

CCTV A (10,20)



CCTV C (-50,20)

2. MNVR TO POISED FOR CAPTURE POSITION

SM 94 PDRS CONTROL

END POS – ITEM 18 -5 6 9 -2 6 -7 4 6 EXEC

ATT – ITEM 21 +9 0 +0 +0 EXEC

CMD CK – ITEM 25 EXEC (GOOD)

RHC

RATE – as reqd (VERN within 10 ft)

BRAKES – OFF (tb-OFF)

MODE – OPR CMD, ENTER (READY lt on)

AUTO SEQ – PROCEED (IN PROG lt on)

When AUTO SEQ IN PROG lt – off:

BRAKES – ON (tb-ON)

PARAM – PORT TEMP

JOINT – CRIT TEMP

POISED FOR CAPTURE posn:

√	X	Y	Z	PITCH	YAW	ROLL	PL ID
	-569	-26	-746	90	0	0	0
	SY	SP	EP	WP	WY	WR	
√	-124.7	+111.2	-122.7	+85.4	+11.0	-103.7	

SM 94 PDRS CONTROL

PL ID – ITEM 3 +3 EXEC

INIT ID – ITEM 24 +3 EXEC

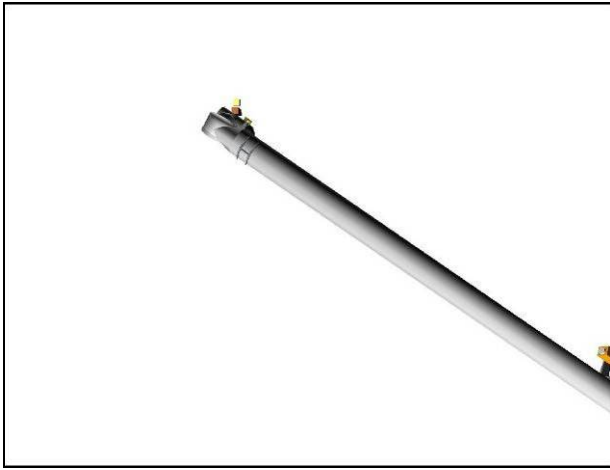

CCTV A (0,80)

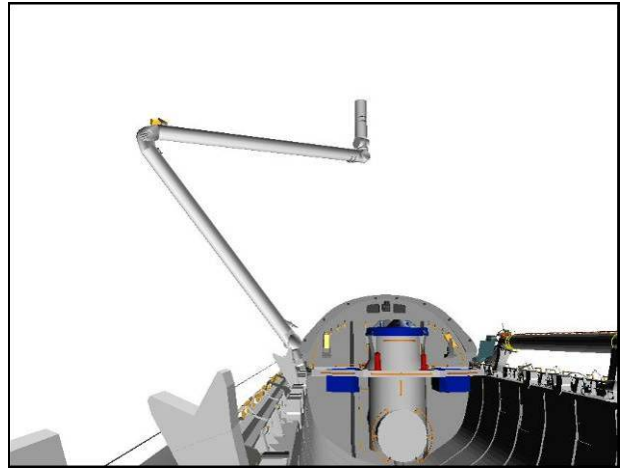

CCTV B (0,10)

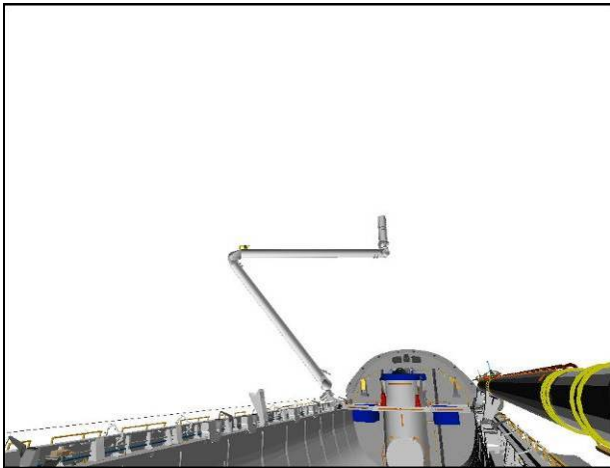

CCTV C (-20,20)

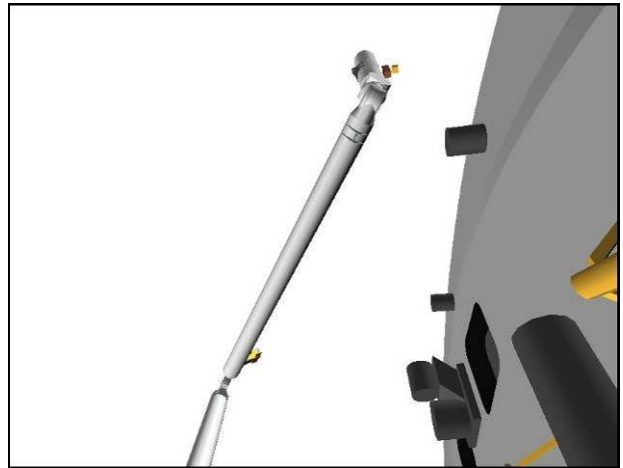

CCTV D (80,50)

Review STS-400 END EFFECTOR CUE CARD

STS-125 GRAPPLE

1. SETUP

MON 1	KEEL
MON 2	B
DNLK	EE
DTV	C

Verify at POISED FOR CAPTURE posn:

X	Y	Z	PITCH	YAW	ROLL	PL ID
-598	-132	-730	360	0	191	3
SY	SP	EP	WP	WY	WR	
-124.7	+111.2	-122.7	+85.4	+11.0	-103.7	

A7U

CCTV – config for grapple

- install PDRS TARGET OVERLAY FOR CTVM
- RMS WRIST, zoom 34.0 HFOV
focus 5 ft

Maintain eyepoint ~18 in when using grapple overlay

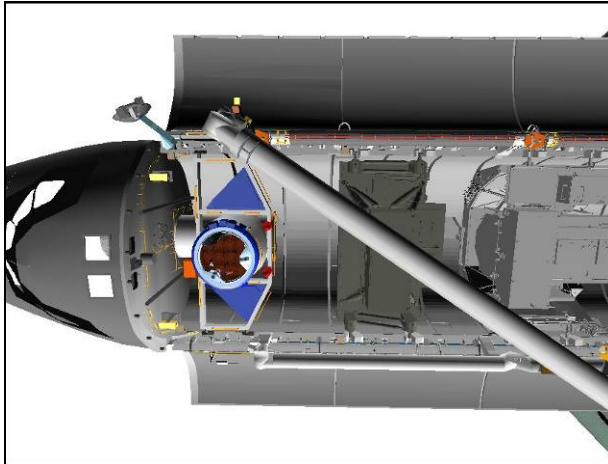

CCTV A (0,80)

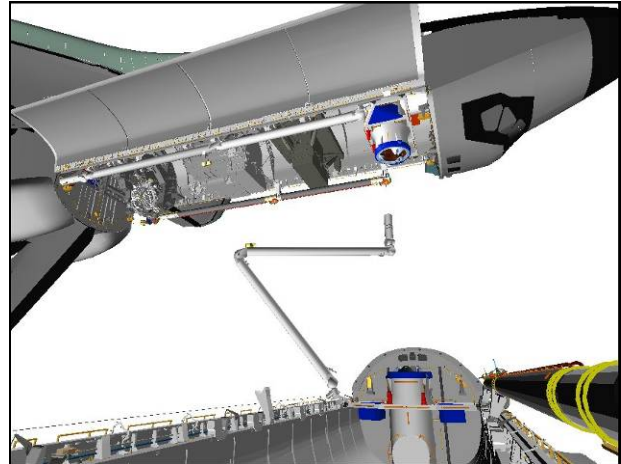

CCTV C (-20,20)

2. MNVR TO STS-125 PRE-GRAPPLE

RHC

RATE – VERN (RATE MIN tb-ON)

Verify orbiter and SRMS go for grapple

EE MODE – AUTO

BRAKES – OFF (tb-OFF)

MODE – END EFF, ENTER

DAP: FREE

Mnvr to STS-125 PRE-GRAPPLE posn:

X	Y	Z	PITCH	YAW	ROLL	PL ID
-687	+6	-761	11	270*	191	3
-581	-25	-756	101	1	91	0
SY	SP	EP	WP	WY	WR	
-118.0	+113.7	-122.3	+77.2	-1.2	-6.0	

*display singularity

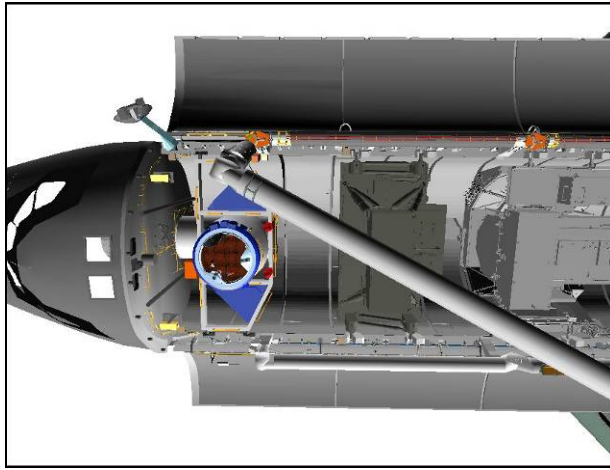

CCTV A (0,80)

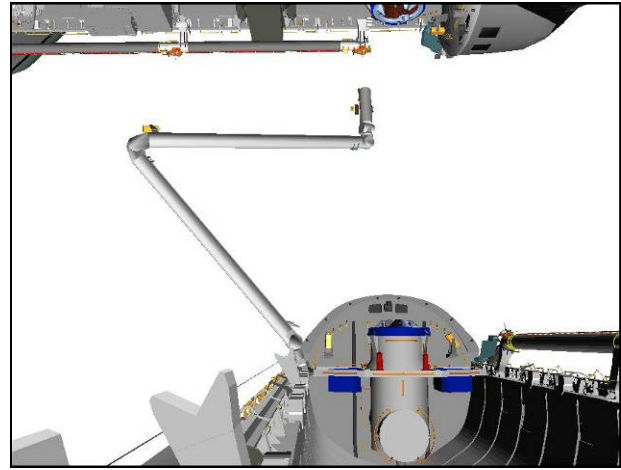

CCTV B (0,10)

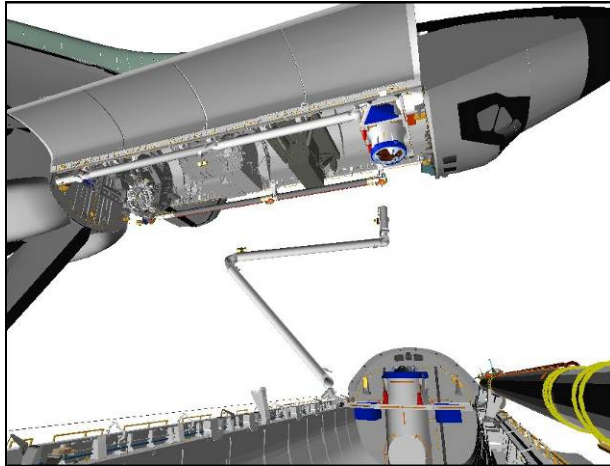

CCTV C (-20,20)

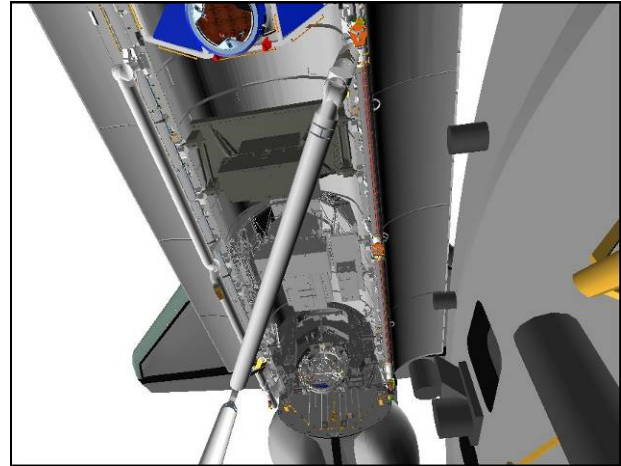

CCTV D (80,50)

3. STS-125 GRAPPLE

CAUTION
Monitor EE tb timing to prevent EE motor burnout

Mnvr to grapple envelope

EE CAPTURE sw – depress (mom)

✓	RIGID	CLOSE	CAPTURE
<input type="checkbox"/>	<input type="checkbox"/>	<input type="checkbox"/>	<input type="checkbox"/>
DERIGID	OPEN	EXTEND	
<input type="checkbox"/>	<input type="checkbox"/>	<input type="checkbox"/>	

CRITICAL TIMES (28 sec total):

CAPTURE tb – gray, then
 CLOSE tb – gray, 3 sec max, then
 RIGID tb – gray, 25 sec max

- * If manual grapple reqd: *
- * EE MODE – MAN *
- * CAPTURE sw – depress (hold until CLOSE tb-gray, 3 sec max) *
- * MAN CONTR – RIGID (hold until RIGID tb-gray, 25 sec max) *

EE MODE – OFF
 BRAKES – ON (tb-ON)

PARAM – PORT TEMP
 JOINT – CRIT TEMP

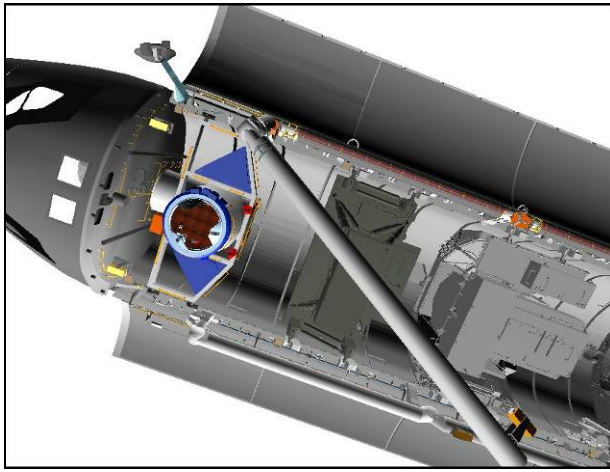

CCTV A (20,80)

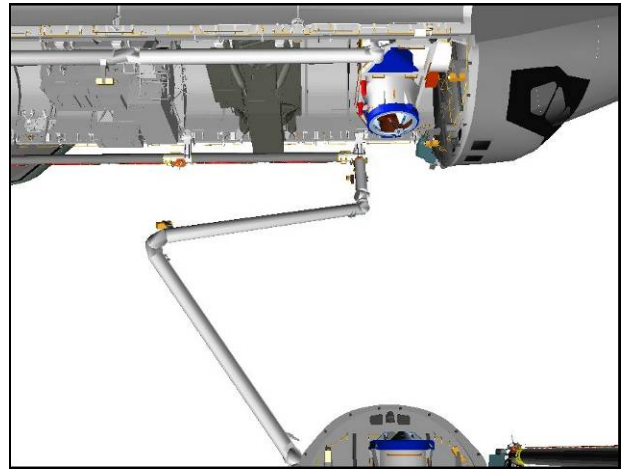

CCTV B (0,20)

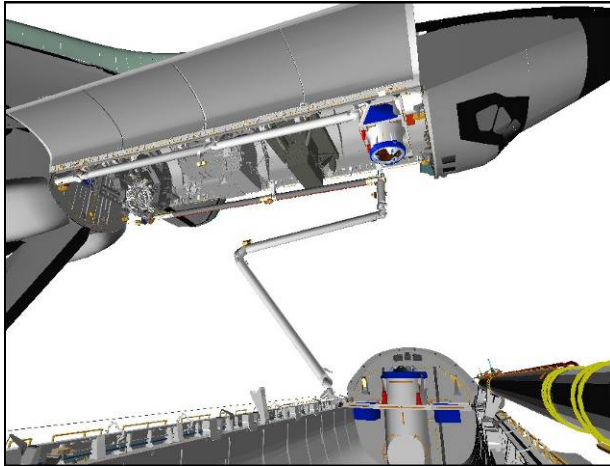

CCTV C (-20,20)



CCTV D (90,60)

Record POS/ATT and Joint Angles:

	X	Y	Z	PITCH	YAW	ROLL	PL ID
							3
Expected	-676	+5	-820	0	270*	180	3
	SY	SP	EP	WP	WY	WR	
Expected	-118.4	+108.9	-107.4	+67.1	-1.1	-6.3	

*display singularity

If not at pre-planned STS-125 Grapple position, perform following OCAS to maneuver to Grapple position

SM 94 PDRS CONTROL

END POS – ITEM 18 -6 7 6 +5 -8 2 0 EXEC
 ATT – ITEM 21 +0 +2 7 0 +1 8 0 EXEC
 CMD CK – ITEM 25 EXEC (GOOD)

RHC

RATE – VERN (RATE MIN tb-ON)
 BRAKES – OFF (tb-OFF)
 MODE – OPR CMD, ENTER (READY It on)
 AUTO SEQ – PROCEED (IN PROG It on)

When AUTO SEQ IN PROG It – off:
 BRAKES – ON (tb-ON)

DAP: as reqd

STS-125 ATTITUDE HOLD/EVA POSITION

1. SETUP

MON 1	A
MON 2	C (B)

SM 94 PDRS CONTROL

√PL ID, ITEM 3: 3

√INIT ID, ITEM 24: 3

Verify at STS-125 GRAPPLE posn:

X	Y	Z	PITCH	YAW	ROLL	PL ID
-676	+5	-820	0	270*	180	3
SY	SP	EP	WP	WY	WR	
-118.4	+108.9	-107.4	+67.1	-1.1	-6.3	

*display singularity

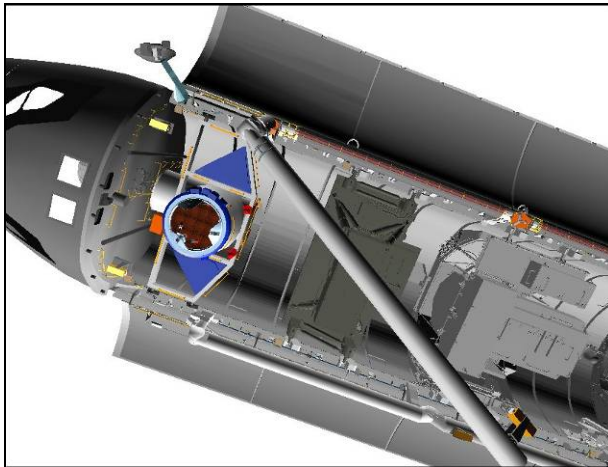

CCTV A (20,80)

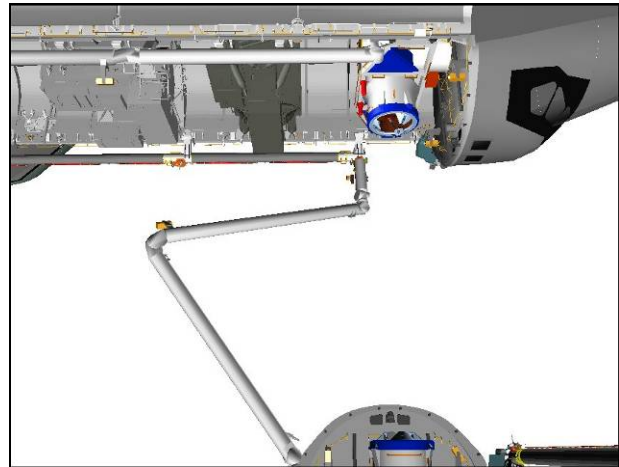

CCTV B (0,20)

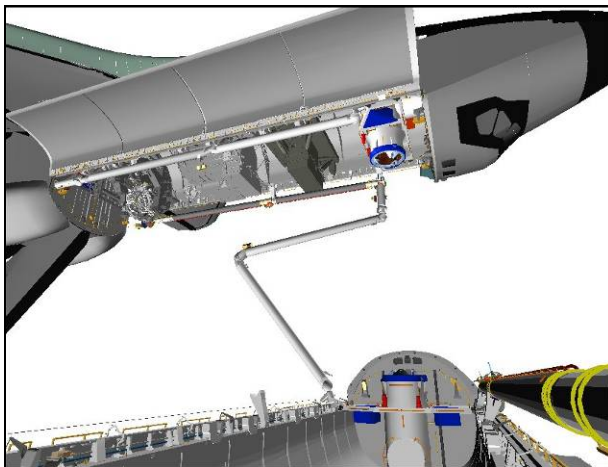

CCTV C (-20,20)

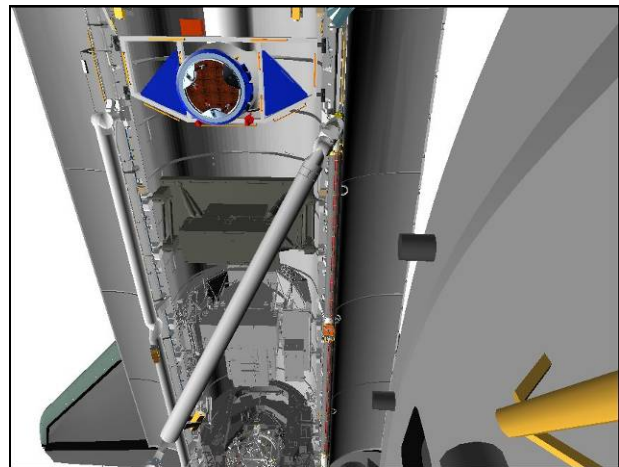

CCTV D (90,60)

2. MNVR TO ATTITUDE HOLD/EVA POSITION

SM 94 PDRS CONTROL

END POS – ITEM 18 -8 7 8 -1 -9 6 4 EXEC

ATT – ITEM 21 +0 +1 +1 8 0 EXEC

CMD CK – ITEM 25 EXEC (GOOD)

RHC

RATE – VERN (RATE MIN tb-ON)

DAP: FREE

BRAKES – OFF (tb-OFF)

MODE – OPR CMD, ENTER (READY It on)

AUTO SEQ – PROCEED (IN PROG It on)

When AUTO SEQ IN PROG It – off:

BRAKES – ON (tb-ON)

PARAM – PORT TEMP

JOINT – CRIT TEMP

DAP: as reqd

ATTITUDE HOLD/EVA posn:

	X	Y	Z	PITCH	YAW	ROLL	PL ID
√	-878	-1	-964	0	1	180	3
	SY	SP	EP	WP	WY	WR	
√	-63.8	+58.6	-29.9	+33.9	-12.8	-47.4	



CCTV A (0,50)

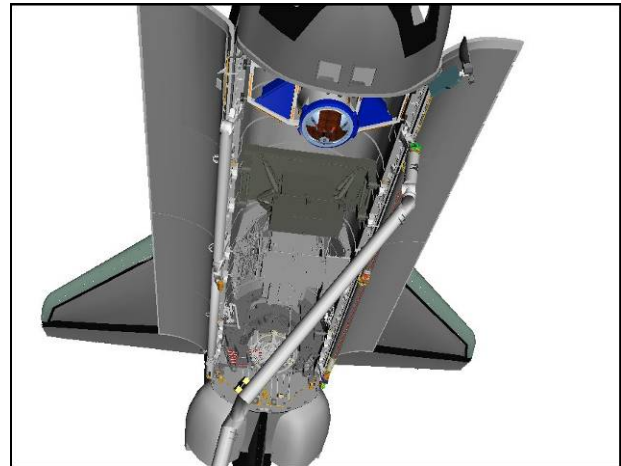

CCTV B (10,40)

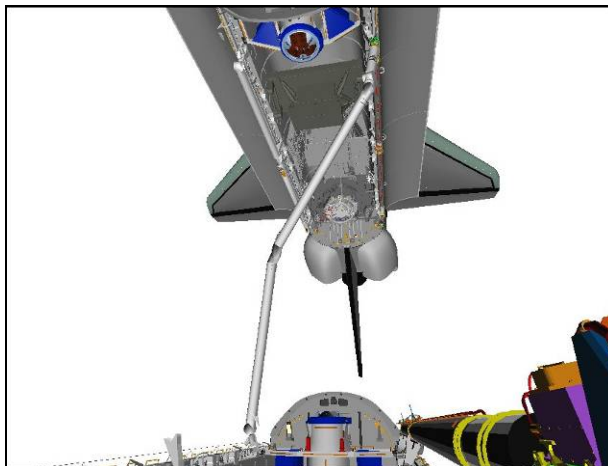

CCTV C (-10,25)

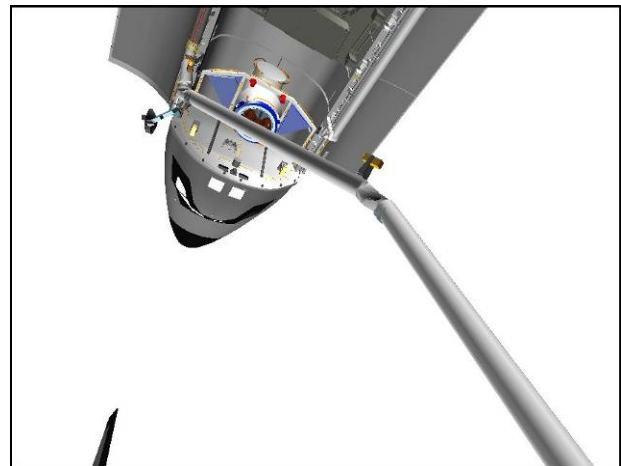

CCTV D (30,45)

STS-125 UNGRAPPLE

NOTE

Nominal STS-125 Ungrapple will be executed from STS-125 RELEASE (RNDZ, STS-400 PROCEDURES). Procedure included in PDRS book for completeness

1. SETUP

MON 1	A (D)
MON 2	C (B)

Verify at ATTITUDE HOLD/EVA posn:

	X	Y	Z	PITCH	YAW	ROLL	PL ID
√	-878	-1	-964	0	1	180	3
	SY	SP	EP	WP	WY	WR	
√	-63.8	+58.6	-29.9	+33.9	-12.8	-47.4	

A7U

CCTV – config for ungrapple
 – RMS WRIST, zoom 34.0 HFOV
 focus 5 ft

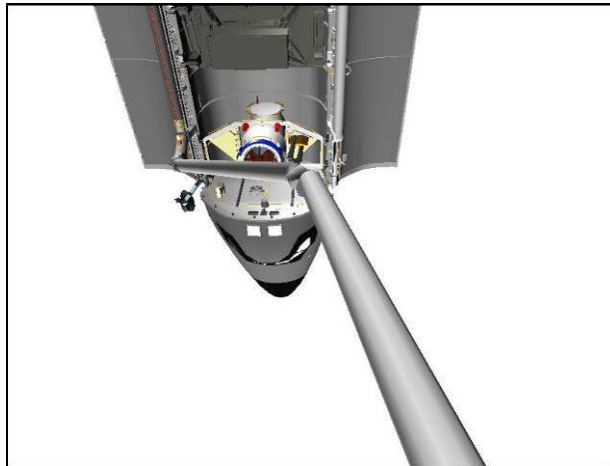

CCTV A (0,50)

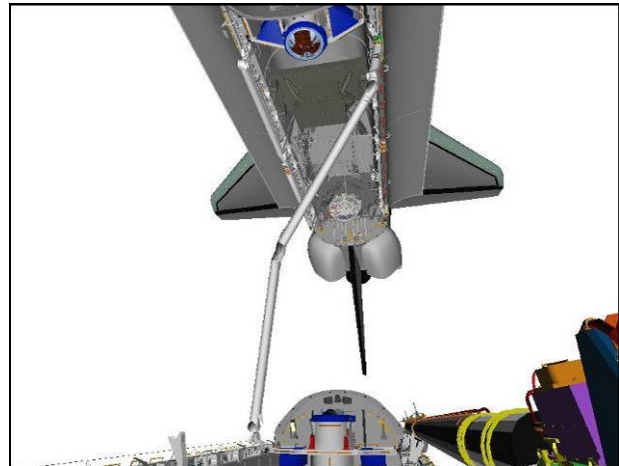

CCTV C (-10,25)

2. STS-125 UNGRAPPLE

RATE – VERN (RATE MIN tb-ON)

BRAKES – OFF (tb-OFF)

MODE – END EFF, ENTER

CAUTION

Monitor EE tb timing to prevent EE motor burnout

SM 169 PDRS STATUS

EE MODE – AUTO

RELEASE sw – depress (mom)

When OPEN tb – gray, mnvr arm clear of grapple pin

	RIGID	CLOSE	CAPTURE
√	<input checked="" type="checkbox"/>	<input checked="" type="checkbox"/>	<input checked="" type="checkbox"/>
	DERIGID	OPEN	EXTEND
	<input type="checkbox"/>	<input type="checkbox"/>	<input type="checkbox"/>

CRITICAL TIMES (28 sec total):

DERIGID tb – gray, 5 sec max, then

OPEN tb – gray, 3 sec max, then

EXTEND tb – gray, 20 sec max

Mnvr to STS-125 UNGRAPPLE posn:

X	Y	Z	PITCH	YAW	ROLL	PL ID
-850	+95	-901	90	349	0	3
SY	SP	EP	WP	WY	WR	
-61.7	+73.1	-62.0	+51.9	-13.8	-45.5	

BRAKES – ON (tb-ON)

EE MODE – OFF

SM 94 PDRS CONTROL

PL ID, ITEM 3 +Q EXEC

INIT ID, ITEM 24 +Q EXEC

- * If manual release required: *
- * EE MODE – MAN *
- * MAN CONTR – DERIGID (hold until DERIGID tb-gray, 5 sec max) *
- * RELEASE sw – depress (hold until OPEN tb-gray, 3 sec max) *
- * *
- * Mnvr arm clear, then *
- * EE MAN CONTR – DERIGID (hold until EXTEND *
- * tb-gray, 20 sec max) *
- * MODE – OFF *



CCTV A (0,50)



CCTV B (0,40)

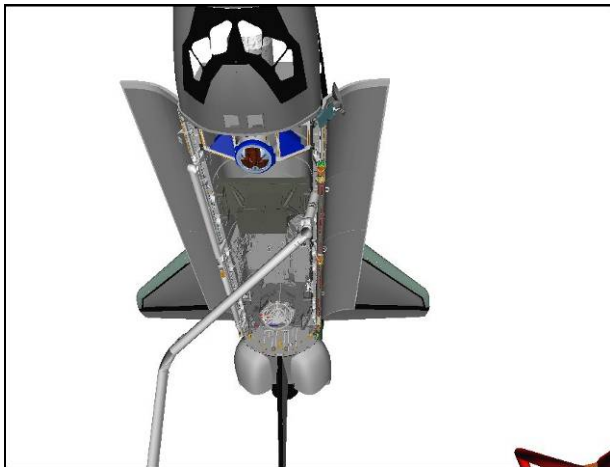

CCTV C (0,40)

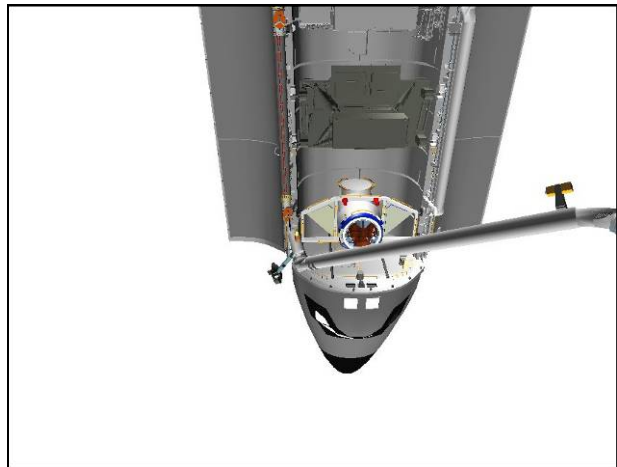

CCTV D (0,60)

3. MNVR TO PRE-CRADLE POSITION

SM 94 PDRS CONTROL

END POS – ITEM 18 -1 2 6 1 -1 4 6 -5 5 1 EXEC
 ATT – ITEM 21 +5 +2 +0 EXEC
 CMD CK – ITEM 25 EXEC (GOOD)

RHC

RATE – as reqd (VERN within 10 ft)

BRAKES – OFF (tb-OFF)
 MODE – OPR CMD, ENTER (READY lt on)
 AUTO SEQ – PROCEED (IN PROG lt on)

When AUTO SEQ IN PROG lt – off:

BRAKES – ON (tb-ON)
 PARAM – PORT TEMP
 JOINT – CRIT TEMP

PRE-CRADLE posn:

	X	Y	Z	PITCH	YAW	ROLL	PL ID
√	-1261	-146	-551	5	2	0	0
	SY	SP	EP	WP	WY	WR	
√	0.0	+25.0	-25.0	+5.0	0.0	0.0	

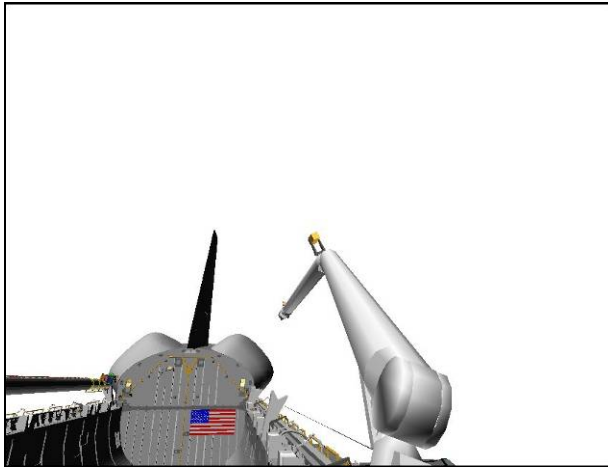

CCTV A (10,20)

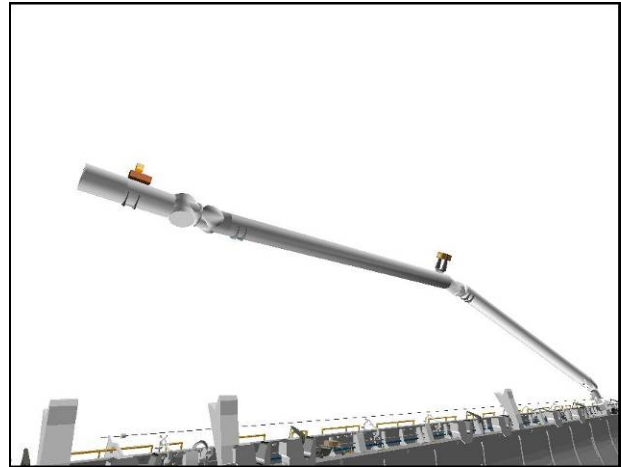

CCTV C (-50,20)

This Page Intentionally Blank

ORBITER SURVEY OPS

I

OBSS ITVC BELLY TILE SURVEY – STBD..... FS 2-2
 – PORT FS 2-9
RMS EE CREW CABIN SURVEY FS 2-27

**ORBITER
SURVEY OPS**

OBSS ITVC BELLY TILE SURVEY – STBD (26 min)

ORBITER
SURVEY OPS

WARNING
Stbd PLBD radiator must be stowed
APAS Docking Ring must be retracted

NOTE

Assumed starting posn is OBSS LDRI/IDC RCC
Survey – Stbd, Point 13P.

For PL ID 5, rates have been set such that Coarse
is used for all Tile Acreage Surveying. Vern rates
required to survey following areas: ET door seals,
landing gear door seals, Elevon Cove

1. SETUP

L10(VTR) BRAKES – ON (tb-ON)
STOP pb – push (no red ● on LCD)

SM 94 PDRS CONTROL

PL ID – ITEM 3 +5 EXEC
INIT ID – ITEM 24 +5 EXEC
AUTO MODES – ITEM 13 +7 EXEC

For survey scan pattern, refer to OBSS SCAN PATTERN CUE CARD – STBD & PORT ITVC BELLY TILE

Verify Stbd LDRI ACAS, Point 13P:

	X	Y	Z	PITCH	YAW	ROLL	PL ID
√	-1328	+464	-221	348	346	12	5
	SY	SP	EP	WP	WY	WR	
√	-74.9	+16.3	-74.3	-43.0	-12.2	-276.6	

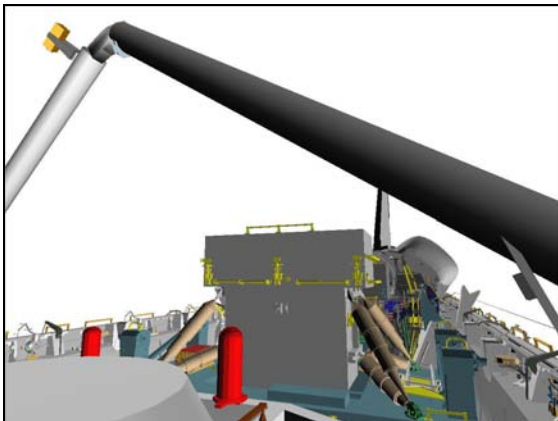

CCTV A (-20,+10)

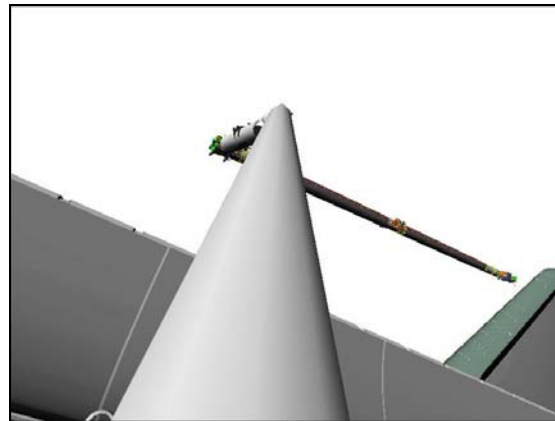

ELBOW (0,-20)

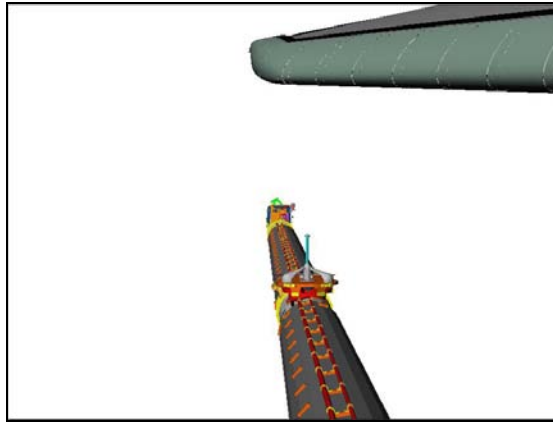

RSC

A7U

√MUX 1 L ← MIDDECK

LDR1 MODE 2 pb – push (ITVC video)
 ZOOM: 17.0 HFOV
 FOCUS: 17 ft

√DTV ← PL2

PAN/TILT to match ITVC view shown below

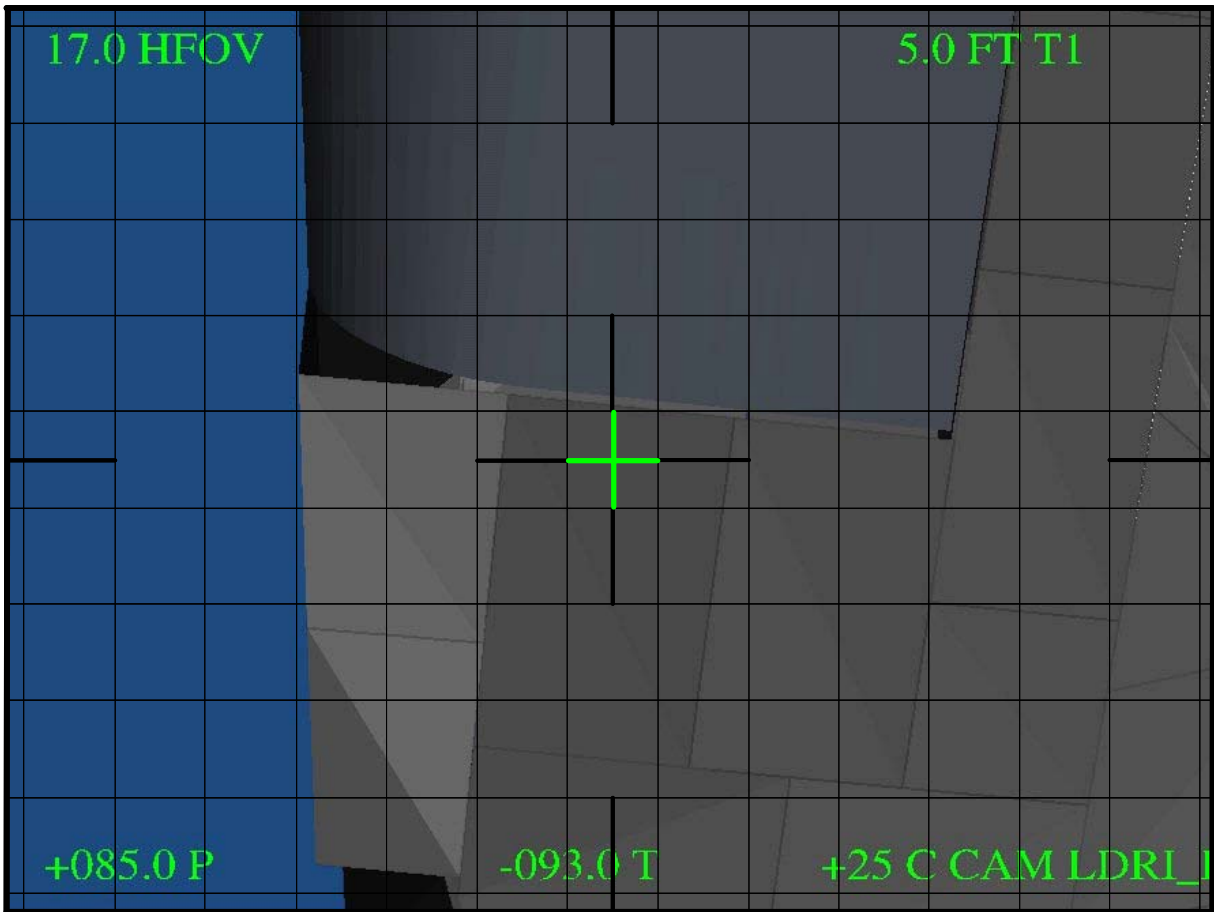

ITVC (85,-93)

√MCC to verify correct sensor view
 Note PAN/TILT: _____, _____

VID OUT – not DTV
 VID IN – not PL2

2. STBD ITVC BELLY TILE ACAS, SECTION 1

Stbd ITVC Belly Tile Clearance Views	Cameras
OBSS-to-PLBD	ELBOW, C, D
OBSS-to-Stbd Wing	ELBOW, RSC
RMS-to-PLB Structures	ELBOW, A, D

RHC √RATE – COARSE (RATE MIN tb-OFF)
 BRAKES – OFF (tb-OFF)
 MODE – AUTO 1, ENTER

- * If unable to enter AUTO mode (no AUTO READY lt): *
- * √POR coordinates and adjust as reqd *

SM 94 PDRS CONTROL

√START PT, ITEM 17: 148



SM 169 PDRS STATUS

Monitor ACAS progress

L10(VTR) REC pb – push, hold
 PLAY pb – push, simo (red ● on LCD)

LCC/PGSC sel ‘Scan Hi-Res’
 AUTO SEQ – PROCEED (IN PROG lt on)

ACAS, pause pts **shaded in bold**, ● col indicates data recording (black = VTR on) (04:45)

Pt	X	Y	Z	PITCH	YAW	ROLL	●
148P Δ	-1328 -37	+464 +6	-221 -130	348 +14	346 +2	12 +1	
149 Δ	-1291 +48	+458 +235	-91 -19	334 +4	345 -22	10 +5	
150 Δ	-1339 -65	+223 +38	-72 -9	332 +1	7 -3	16 +4	
151 Δ	-1274 +55	+185 -309	-63 +130	331 -9	12 +25	14 -14	
152P Δ	-1329 0	+494 +247	-193 -35	343 +2	344 -20	19 +13	

3. STBD ITVC BELLY TILE ACAS, SECTION 2

When AUTO SEQ READY lt – on:



RHC RATE – VERN (RATE MIN tb-ON)

A7U √DTV ← PL2
 FOCUS: 12 ft

 VID OUT – not DTV
 VID IN – not PL2

 AUTO SEQ – PROCEED (IN PROG lt on)

ACAS, pause pts **shaded in bold**, ● col indicates data recording (black = VTR on) (11:15)

Pt	X	Y	Z	PITCH	YAW	ROLL	●
152P Δ	-1329 0	+494 +247	-193 -35	343 +2	344 -20	19 +13	
153 Δ	-1329 -86	+247 +86	-158 -61	343 +1	7 -9	13 +2	
154 Δ	-1243 -98	+161 +13	-97 +57	342 +1	16 -8	14 -3	
155 Δ	-1145 -170	+148 -7	-154 +5	339 +3	22 +1	20 -3	
156 Δ	-975 +3	+155 -52	-159 +7	335 0	20 +2	23 -4	
157 Δ	-978 +174	+207 +37	-166 -13	334 -5	16 +1	26 +13	
158 Δ	-1152 -9	+170 -54	-153 +11	343 +4	19 +1	13 -5	
159 Δ	-1143 -182	+224 -6	-164 +7	338 +3	16 -3	17 -8	
160P Δ	-961 +69	+230 -35	-171 -46	332 -2	15 +9	26 +7	

4. STBD ITVC BELLY TILE ACAS, SECTION 3

When AUTO SEQ READY It – on:

RHC RATE – COARSE (RATE MIN tb-OFF)

A7U √DTV ← PL2
FOCUS: 13 ft

VID OUT – not DTV

VID IN – not PL2

AUTO SEQ – PROCEED (IN PROG It on)

ACAS, pause pts **shaded in bold**, ● col indicates data recording (black = VTR on) (10:00)

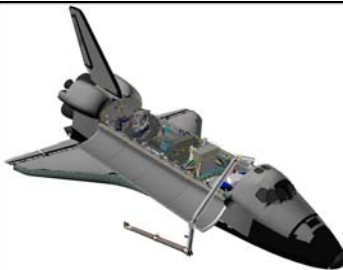
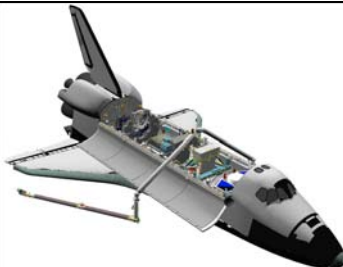
Pt	X	Y	Z	PITCH	YAW	ROLL	●
160P Δ	-961 +69	+230 -35	-171 -46	332 -2	15 +9	26 +7	
161 Δ	-1030 +115	+265 +9	-125 -16	336 -3	10 +2	16 +3	
162 Δ	-1145 +1	+256 +72	-109 -5	340 -2	9 -10	12 -5	
163 Δ	-1146 +56	+184 -41	-104 0	340 0	17 +3	20 -2	
164 Δ	-1202 +55	+225 -20	-104 +2	340 0	14 +5	21 +5	
165 Δ	-1257 -72	+245 +25	-106 -1	341 0	11 0	15 +2	
166 Δ	-1185 -36	+220 -48	-105 +4	341 +1	12 +3	13 0	
167 Δ	-1149 +138	+268 -9	-109 -5	340 -2	9 +5	12 -3	
168 Δ	-1287 -8	+277 -60	-104 +4	342 -1	3 +4	13 -1	
169 Δ	-1279 -261	+337 +47	-108 +16	343 +8	359 -7	13 +4	
170 Δ	-1018 +142	+290 -95	-124 0	335 -4	7 +5	12 -9	
171 Δ	-1160 +118	+385 +10	-124 -4	339 -2	359 +4	19 +4	
172 Δ	-1278 -10	+375 -54	-120 +6	341 -1	357 +4	14 -3	
173 Δ	-1268 -108	+429 +69	-126 -10	342 -3	352 -1	15 +15	
174 Δ	-1160 +115	+360 -95	-116 +9	344 +4	357 +2	1 -15	
175 Δ	-1275 +53	+455 -9	-125 +96	342 -7	350 +4	14 +1	
176P Δ	-1328 0	+464 0	-221 0	348 0	346 0	12 0	

5. RECONFIGURE FOR OBSS LDRI/IDC RCC SURVEY – STBD

When AUTO SEQ IN PROG It – off:

LCC/PGSC sel 'Stop Scan'
L10(VTR) STOP pb – push (no red ●)

BRAKES – ON (tb-ON)

Verify mnvr to Stbd LDRI ACAS, Point 13P complete:

X	Y	Z	PITCH	YAW	ROLL	PL ID
-1328	+464	-221	348	346	12	5
SY	SP	EP	WP	WY	WR	
-74.9	+16.3	-74.3	-43.0	-12.2	-276.6	

SM 94 PDRS CONTROL

PL ID – ITEM 3 +2 EXEC
INIT ID – ITEM 24 +2 EXEC
AUTO MODES – ITEM 13 +1 EXEC

A7U

MUX 1 L ← MIDDECK
LDRI MODE 6 pb – push (brighter flickering LDRI video)

DTV ← PL2

PAN/TILT to match ITVC view shown below

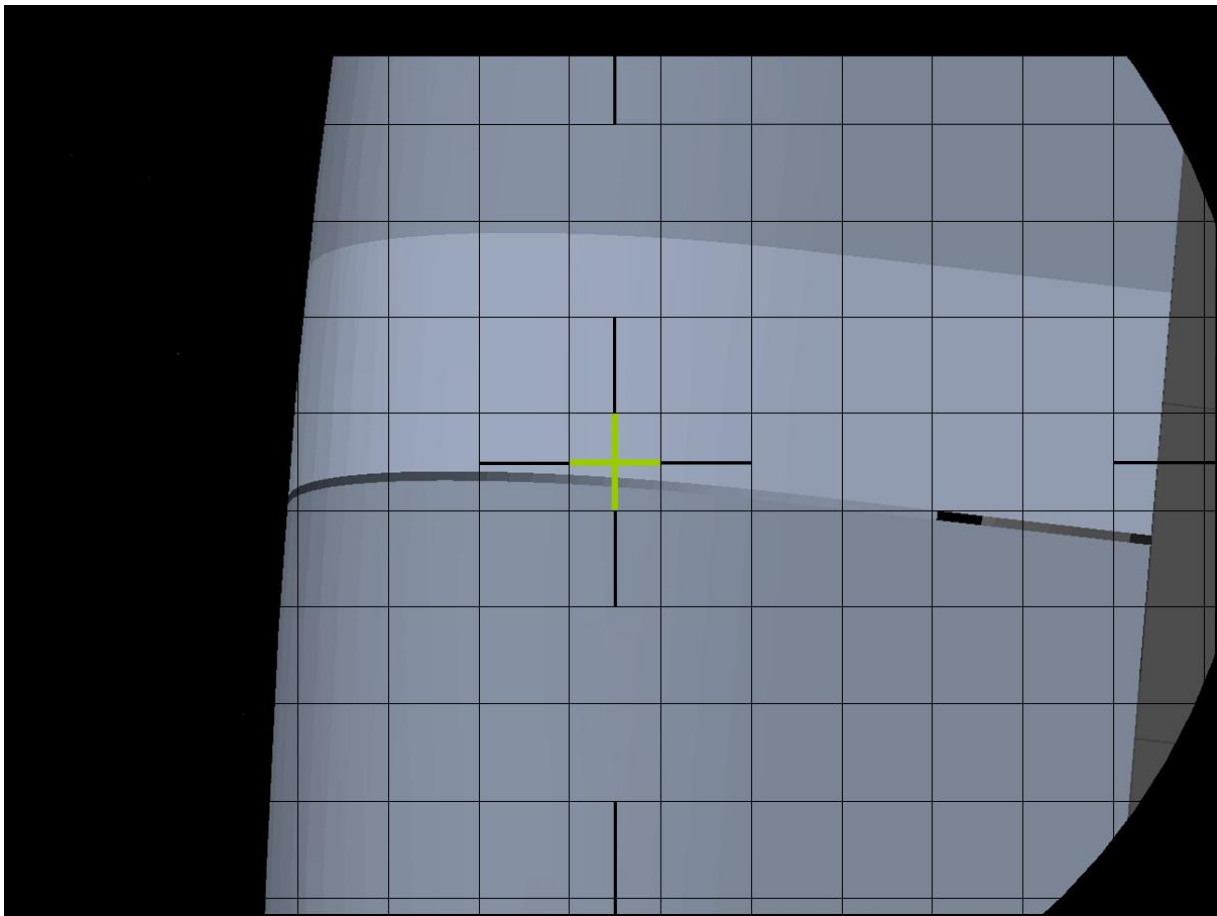

LDRI: +85,-60

√MCC to verify correct sensor view
Note PAN/TILT: _____, _____

IF CONTINUING OBSS OPS WITH STBD RCC SURVEY

Go to OBSS LDRI/IDC RCC SURVEY – STBD, step 5b

This Page Intentionally Blank

OBSS ITVC BELLY TILE SURVEY – PORT (110 min)

WARNING
Port PLBD radiator must be stowed

NOTE

Assumed starting posn is OBSS LDRI/IDC RCC
Survey – Port, Point 114P.

For PL ID 5, the rates have been set such that Coarse is used for all Tile Acreage Surveying. Vern rates required to survey the following areas: ET door seals, landing gear door seals, Elevon Cove.

Uplink of new autosequence required

1. SETUP
BRAKES – ON (tb-ON)

SM 94 PDRS CONTROL

PL ID – ITEM 3 +5 EXEC
INIT ID – ITEM 24 +5 EXEC
AUTO MODES – ITEM 13 +1 EXEC

For survey scan pattern, refer to OBSS SCAN PATTERN CUE CARD – PORT ITVC BELLY TILE

Verify Port LDRI ACAS, Point 114P:

	X	Y	Z	PITCH	YAW	ROLL	PL ID
√	-1323	-537	-315	346	348	282	5
	SY	SP	EP	WP	WY	WR	
√	+80.9	+49.1	-50.2	+5.9	+0.6	-87.1	

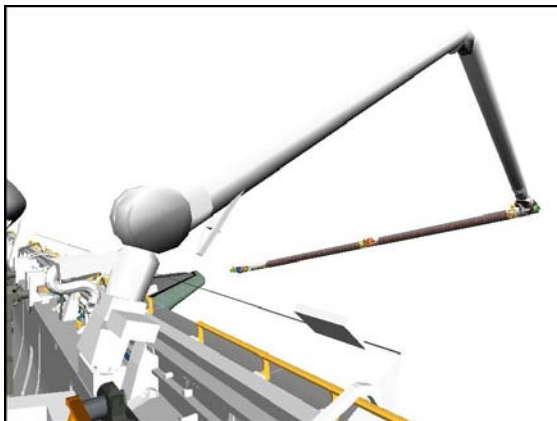

CCTV A (40,0)

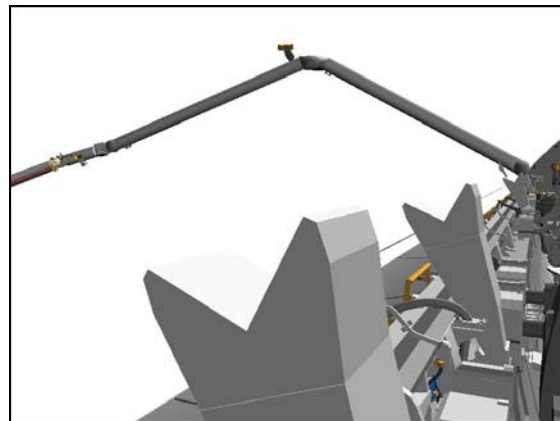

CCTV B (-25,-5)



ELBOW (-30,10)

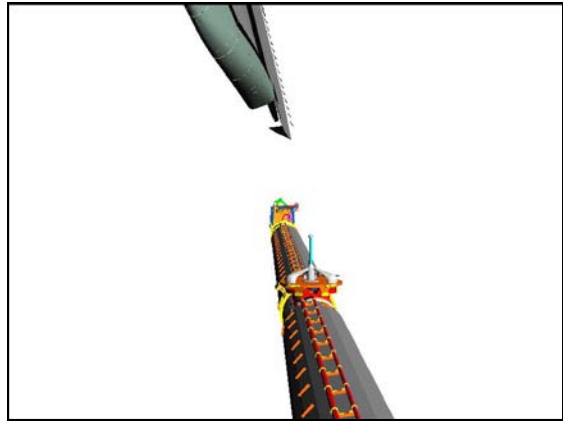

RSC

A7U

√MUX 1 L ← MIDDECK

LDRI MODE 2 pb – push (ITVC video)

ZOOM: 20.0 HFOV

FOCUS: 13 ft

√DTV ← PL2

PAN/TILT to match ITVC view shown below

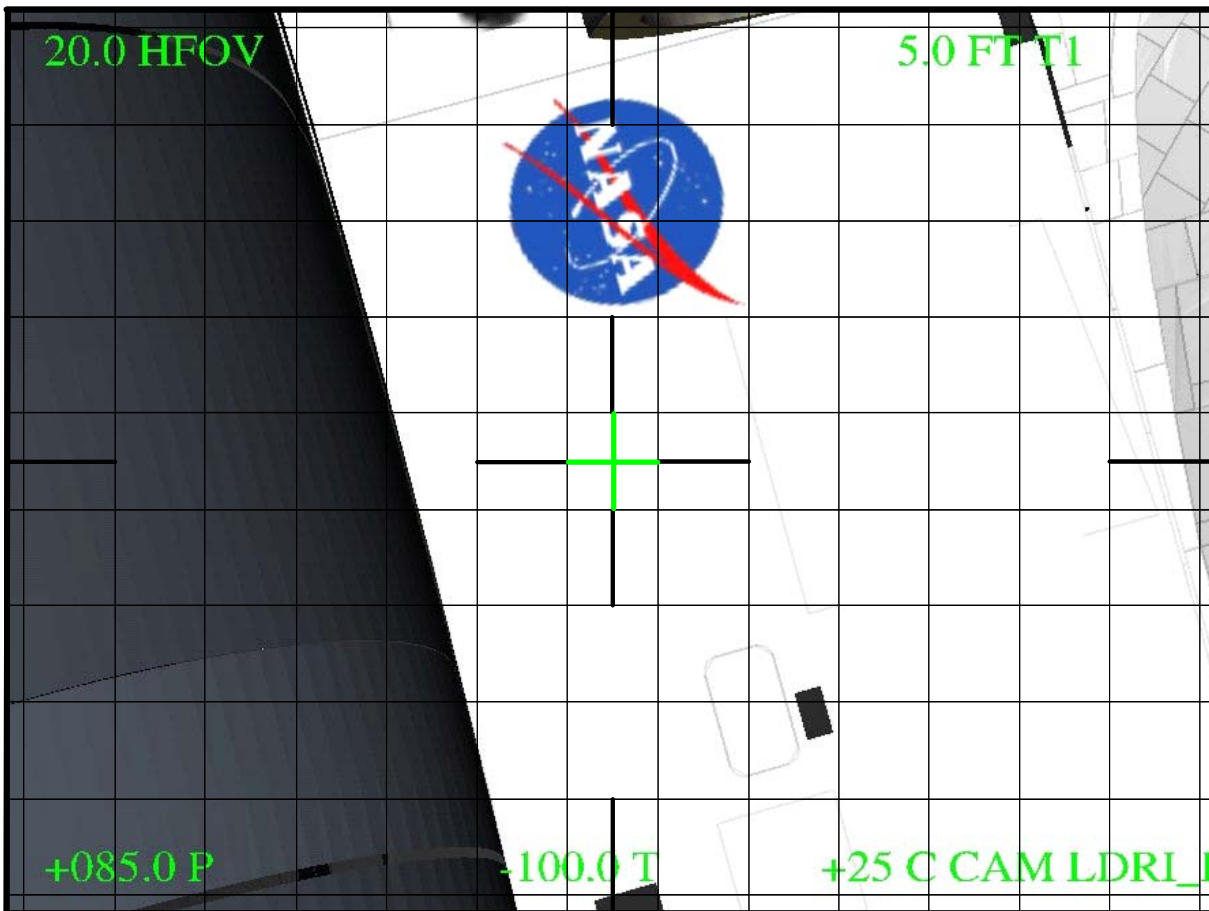

ITVC (85,-100)

√MCC to verify correct sensor view

Note PAN/TILT: _____, _____

VID OUT – not DTV
 VID IN – not PL2

2. PORT ITVC BELLY TILE ACAS, SECTION 1

Port ITVC Belly Tile Clearance Views	Cameras
RMS-to-PLBD	ELBOW, A, B
OBSS-to-Stbd Wing	ELBOW, RSC
RMS-to-PLB Structures	A, B

RHC √RATE – COARSE (RATE MIN tb-OFF)
 BRAKES – OFF (tb-OFF)
 MODE – AUTO 1, ENTER

* If unable to enter AUTO mode (no AUTO READY It): *
 * √POR coordinates and adjust as reqd *

SM 94 PDRS CONTROL

√START PT, ITEM 17: 1



SM 169 PDRS STATUS

Monitor ACAS progress

L10(VTR) REC pb – push, hold
 PLAY pb – push, simo (red ● on LCD)

LCC/PGSC sel 'Scan Hi-Res'
 AUTO SEQ – PROCEED (IN PROG It on)

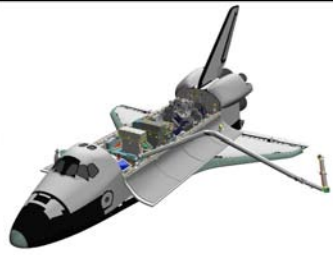
ACAS, pause pts **shaded in bold**, ● col indicates data recording (black = VTR on) (13:45)

Pt	X	Y	Z	PITCH	YAW	ROLL	●
1P Δ	-1323 +41	-537 -67	-315 -218	346 -16	348 -15	282 -81	
2 Δ	-1364 +68	-470 -353	-97 -19	357 -3	2 +25	3 -1	
3 Δ	-1432 +113	-117 +30	-78 +2	0 +1	337 -1	4 +7	
4 Δ	-1545 -20	-147 -216	-80 +5	356 +10	338 +12	356 -10	
5 Δ	-1525 -88	+69 -49	-85 +3	351 -5	324 +12	4 +1	
6 Δ	-1437 -69	+118 +65	-88 -29	355 -2	312 -10	2 -2	
7 Δ	-1368 +130	+53 +19	-59 +12	359 0	322 -10	5 0	
8 Δ	-1498 -38	+34 +102	-71 +9	359 +2	332 +1	5 -5	
9 Δ	-1460 -70	-68 0	-80 0	0 0	331 0	11 0	
10 Δ	-1390 +25	-68 -123	-80 +2	0 0	331 0	11 0	
11 Δ	-1415 -47	+55 +15	-82 -24	0 -2	331 -2	11 +4	
12 Δ	-1368 +3	+40 +518	-58 +133	0 -7	333 -27	7 +5	
13P Δ	-1371 +2	-478 -467	-191 -35	6 +6	359 +36	359 -10	

3. PORT ITVC BELLY TILE ACAS, SECTION 2

When AUTO SEQ READY It – on:

RHC RATE – VERN (RATE MIN tb-ON)

A7U √DTV ← PL2
FOCUS: 9 ft

VID OUT – not DTV

VID IN – not PL2

AUTO SEQ – PROCEED (IN PROG It on)

ACAS, pause pts **shaded in bold**, ● col indicates data recording (black = VTR on) (13:00)

Pt	X	Y	Z	PITCH	YAW	ROLL	●
13P Δ	-1371 +2	-478 -467	-191 -35	6 +6	359 +36	359 -10	
14 Δ	-1373 +13	-11 -211	-156 +20	8 -8	324 +16	12 +14	
15 Δ	-1386 -50	+200 +85	-176 -16	3 +6	306 -7	357 -9	
16 Δ	-1336 0	+115 +240	-160 -1	7 +1	313 -17	11 +2	
17 Δ	-1336 -44	-125 -6	-159 0	4 0	330 +1	7 -2	
18 Δ	-1292 +12	-119 -219	-159 0	5 +2	329 +18	9 -4	
19P Δ	-1304 -52	+100 +35	-159 -53	8 +2	311 -4	16 -3	



4. PORT ITVC BELLY TILE ACAS, SECTION 3

When AUTO SEQ READY It – on:

RHC RATE – COARSE (RATE MIN tb-OFF)



A7U √DTV ← PL2
FOCUS: 13 ft

VID OUT – not DTV

VID IN – not PL2

AUTO SEQ – PROCEED (IN PROG It on)

ACAS, pause pts **shaded in bold**, ● col indicates data recording (black = VTR on) (08:00)

Pt	X	Y	Z	PITCH	YAW	ROLL	●
19P Δ	-1304 -52	+100 +35	-159 -53	8 +2	311 -4	16 -3	
20 Δ	-1252 -252	+65 +52	-106 +7	8 -9	315 +14	19 +14	
21 Δ	-1000 -32	+13 -115	-113 +22	359 +14	299 -6	359 +1	
22 Δ	-968 -206	+128 +44	-135 -3	346 -3	305 +36	0 -6	
23 Δ	-762 -341	+84 +27	-132 +2	207 -5	272 +52	216 -10	
24 Δ	-421 -151	+57 +36	-134 +66	174 +15	324 0	173 +1	
25P Δ	-270 +110	+21 +46	-200 -22	160 +6	324 -3	174 +19	

5. PORT ITVC BELLY TILE ACAS, SECTION 4

When AUTO SEQ READY It – on:

RHC RATE – VERN (RATE MIN tb-ON)



A7U √DTV ← PL2
FOCUS: 9 ft

VID OUT – not DTV

VID IN – not PL2

AUTO SEQ – PROCEED (IN PROG It on)

ACAS, pause pts **shaded in bold**, ● col indicates data recording (black = VTR on) (03:30)

Pt	X	Y	Z	PITCH	YAW	ROLL	●
25P Δ	-270 +110	+21 +46	-200 -22	160 +6	324 -3	174 +19	
26 Δ	-380 +5	-25 +40	-178 +2	169 -2	315 +5	196 +3	
27 Δ	-385 -129	-65 -14	-180 +22	174 +9	319 +10	201 -3	
28P Δ	-256 +188	-51 +83	-202 -60	165 -13	329 -4	201 +7	

6. PORT ITVC BELLY TILE ACAS, SECTION 5

When AUTO SEQ READY It – on:



RHC RATE – COARSE (RATE MIN tb-OFF)

A7U √DTV ← PL2
 FOCUS: 13 ft

VID OUT – not DTV
VID IN – not PL2

AUTO SEQ – PROCEED (IN PROG It on)

ACAS, pause pts **shaded in bold**, ● col indicates data recording (black = VTR on) (06:15)

Pt	X	Y	Z	PITCH	YAW	ROLL	●
28P Δ	-256 +188	-51 +83	-202 -60	165 -13	329 -4	201 +7	
29 Δ	-444 -26	-134 -119	-142 -13	183 -4	325 -12	209 -6	
30 Δ	-418 +515	-15 -90	-129 0	182 -15	313 -78	202 -2	
31 Δ	-933 -18	+75 +88	-129 -11	344 +1	307 -17	358 -2	
32P Δ	-915 +352	-13 -23	-118 -12	349 -8	323 -6	6 -1	

Note PAN/TILT: _____, _____

7. ET DOORS ITVC SURVEY

When AUTO SEQ READY It – on:

A7U

√MUX 1 L ← MIDDECK

√DTV ← PL2

CAMR CMD PAN: +32

TILT: -119

ZOOM: 4.0 HFOV

FOCUS: best focus (~35 ft)

LT LEVEL pb – push

NIGHT pb – push

PAN/TILT to match ITVC view shown below

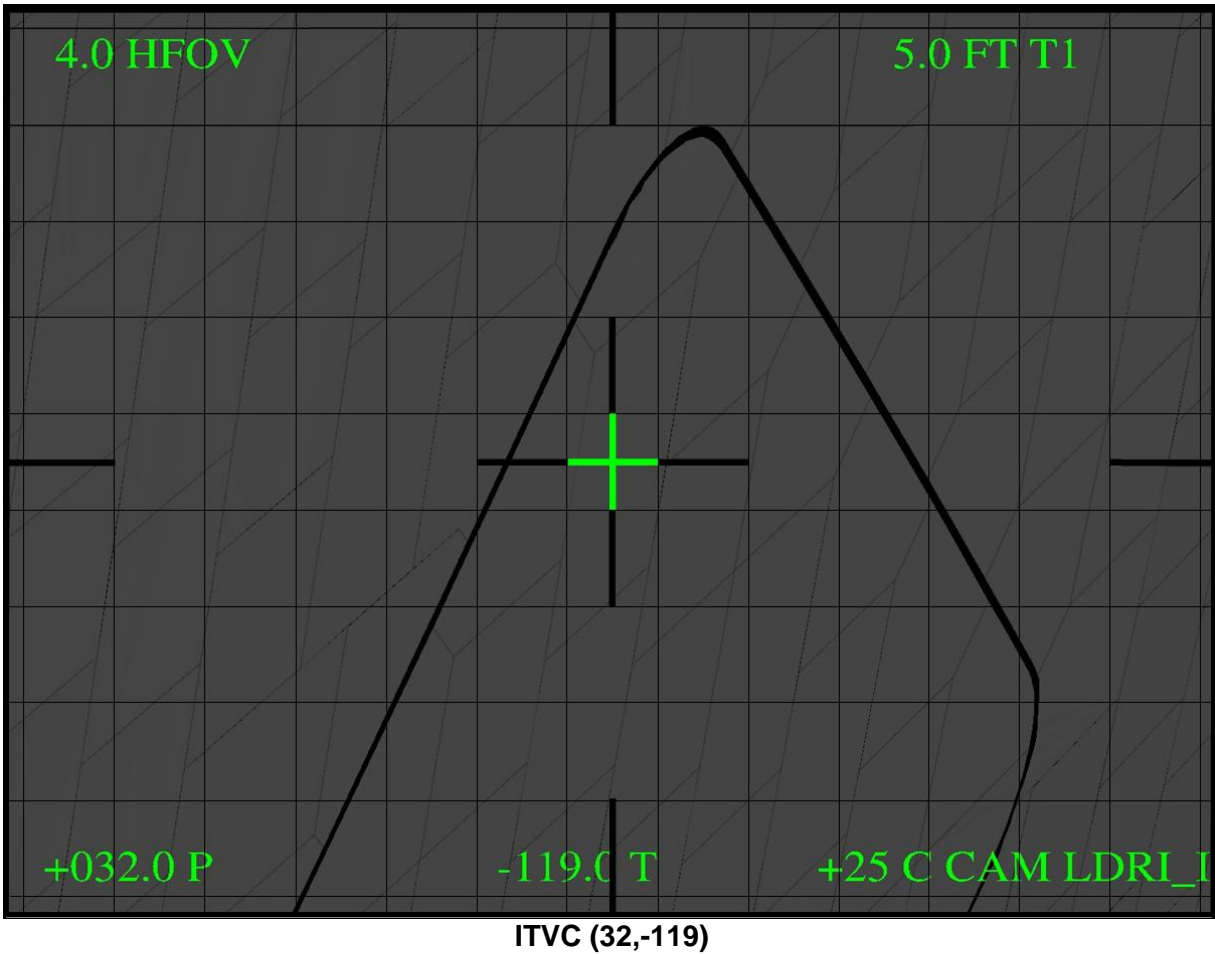

√MCC to verify correct sensor view
Note PAN/TILT: _____, _____

ZOOM: 18.0 HFOV
CAMR CMD PAN: +53
 TILT: -139
ZOOM: 4.0 HFOV
FOCUS: best focus (~35 ft)

PAN/TILT to match ITVC view shown below

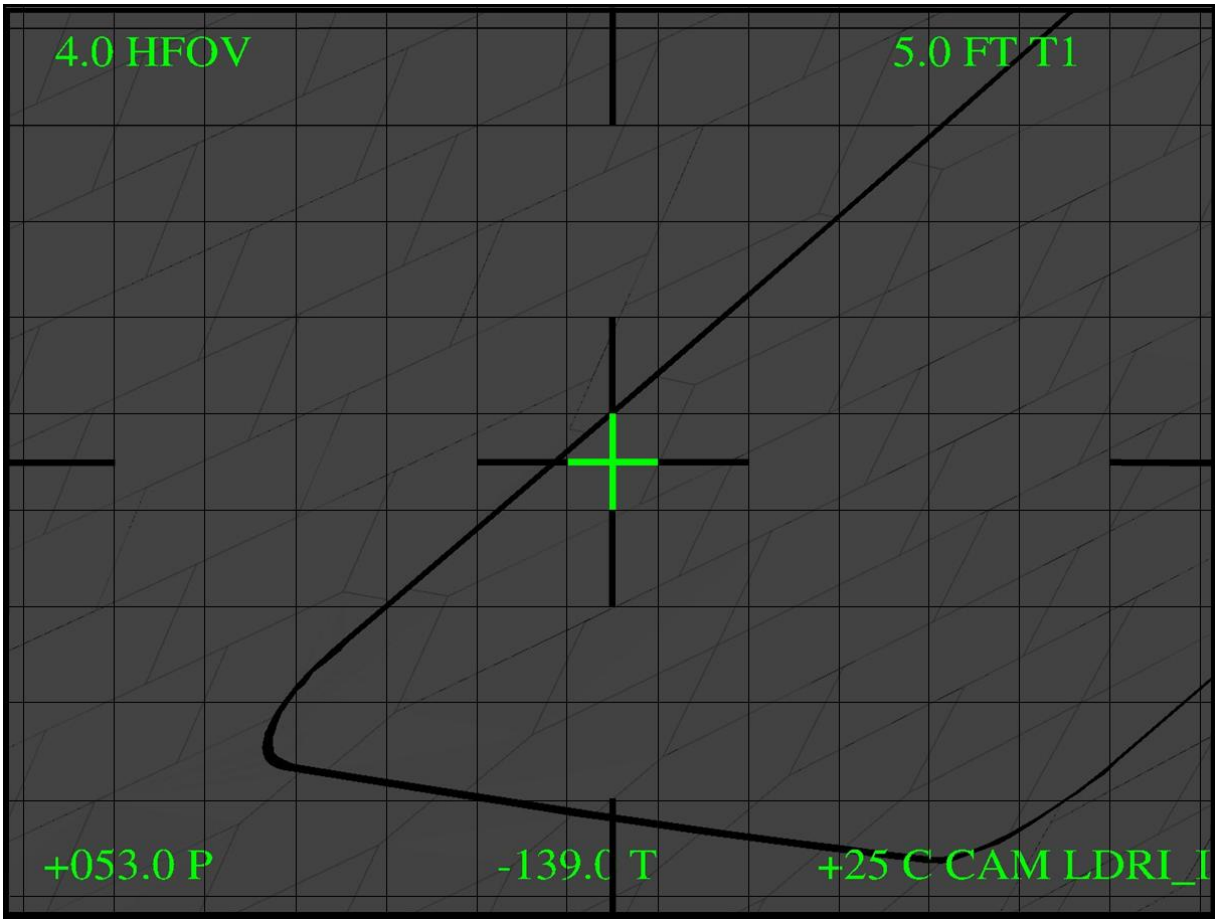

ITVC (53,-139)

√MCC to verify correct sensor view
Note PAN/TILT: _____, _____

A7U

√MUX 1 L ← MIDDECK
√DTV ← PL2

ZOOM: 20.0 HFOV
CAMR CMD PAN: +85
 TILT: -100
FOCUS: 13 ft

LT LEVEL pb – push
DAY pb – push

PAN/TILT to match ITVC view shown below

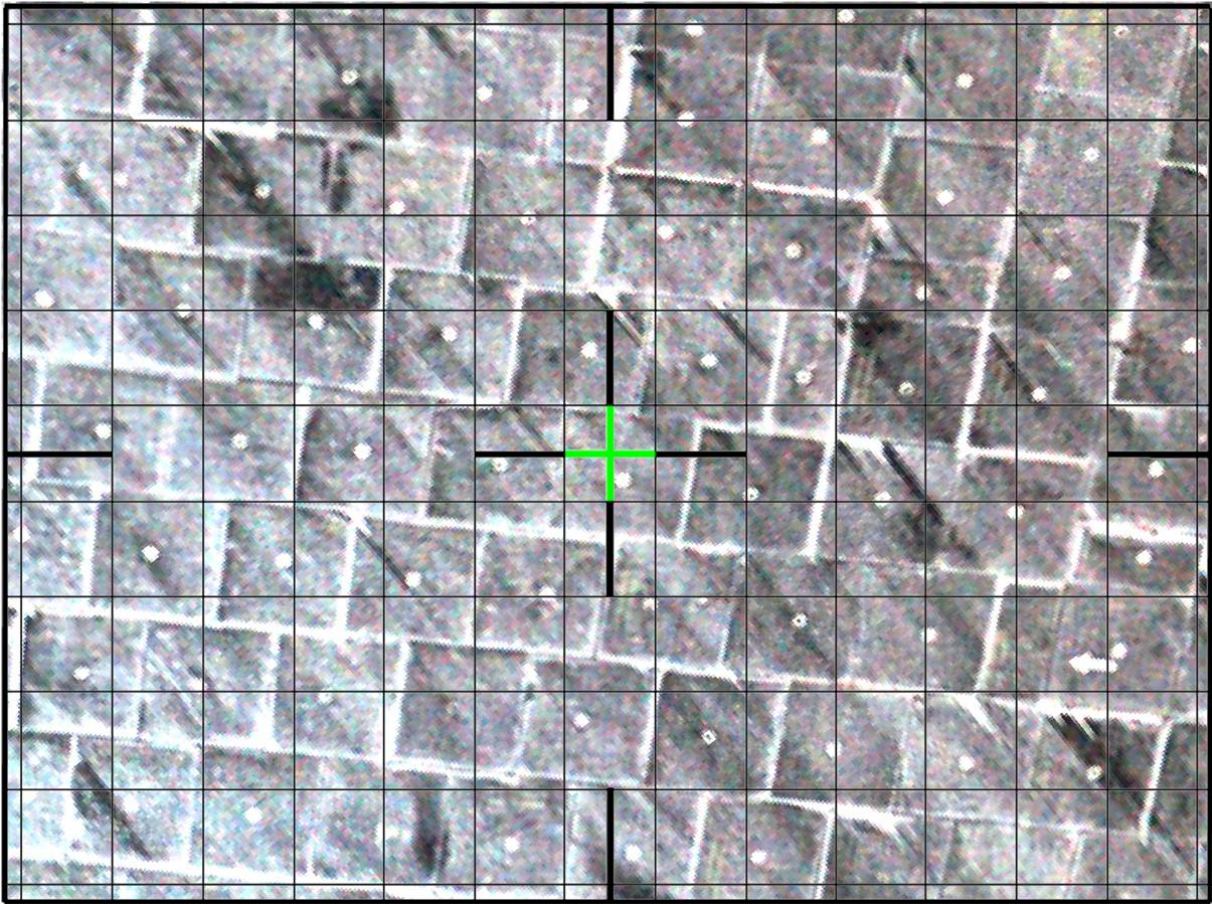

ITVC (85,-100)



√MCC to verify correct sensor view

8. PORT ITVC BELLY TILE ACAS, SECTION 6
VID OUT – not DTV
VID IN – not PL2

RHC √RATE – COARSE (RATE MIN tb-OFF)

AUTO SEQ – PROCEED (IN PROG It on)

ACAS, pause pts **shaded in bold**, ● col indicates data recording (black = VTR on) (09:45)

Pt	X	Y	Z	PITCH	YAW	ROLL	●
32P Δ	-915 +352	-13 -23	-118 -12	349 -8	323 -6	6 -1	
33 Δ	-1267 -40	+10 +47	-106 +3	358 +5	329 -7	8 -8	
34 Δ	-1227 -345	-37 +61	-109 +16	357 -2	335 +16	18 +22	
35 Δ	-882 0	-98 -133	-125 +3	341 -1	323 +11	350 -5	
36 Δ	-882 -386	+35 +109	-128 +14	344 -3	311 +69	352 +10	
37 Δ	-496 +4	-74 +91	-142 +12	211 0	304 +7	213 +6	
38 Δ	-500 +66	-165 -13	-154 -10	213 +7	313 +3	216 -5	
39 Δ	-566 -22	-152 -74	-144 -11	200 0	314 -8	208 -2	
40P Δ	-544 -18	-78 +44	-133 -3	201 -1	306 +4	210 +3	

When AUTO SEQ READY It – on:

A7U

√MUX 1 L ← MIDDECK

√DTV ← PL2

PAN/TILT to match ITVC view shown below

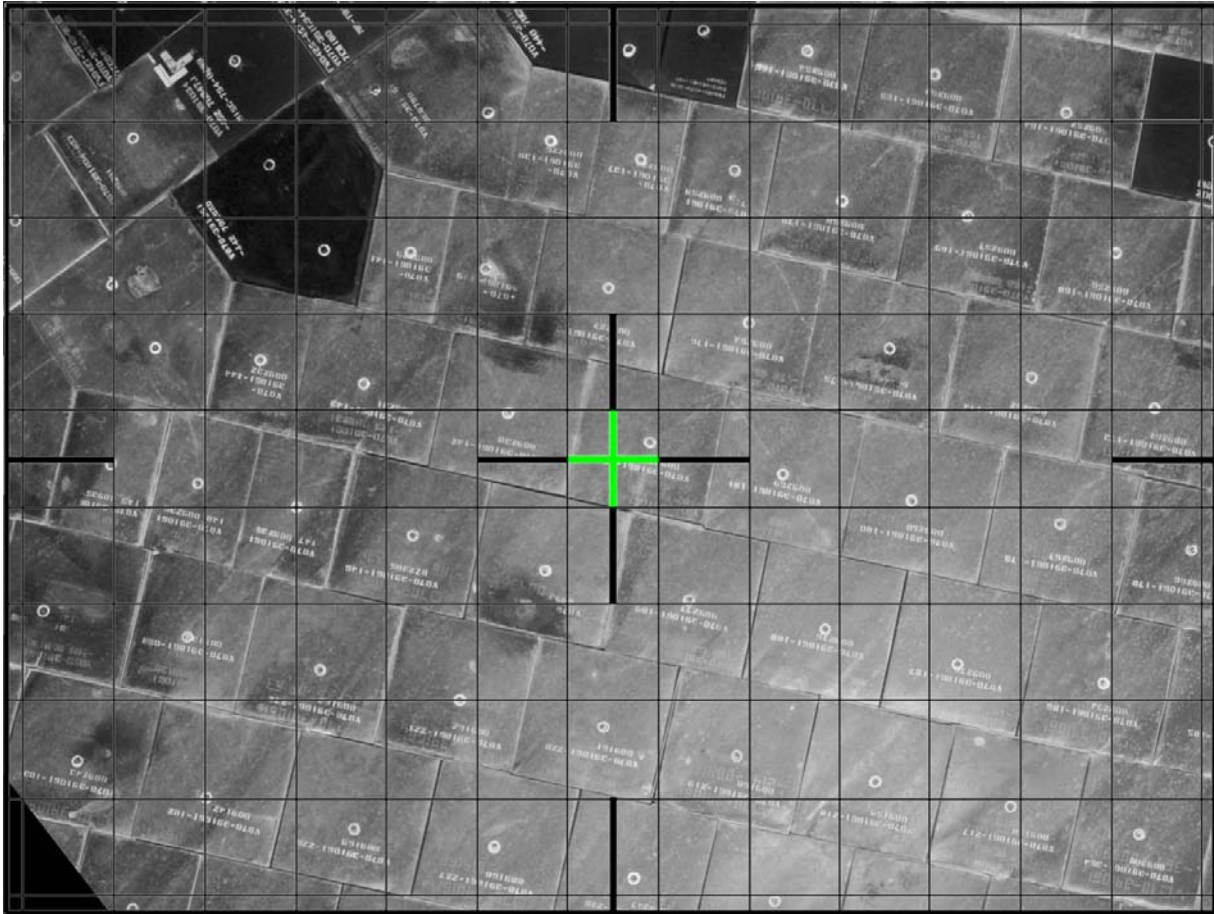

ITVC (85,-75)

√MCC to verify correct sensor view
Note PAN/TILT: _____, _____

VID OUT – not DTV
VID IN – not PL2

RHC √RATE – COARSE (RATE MIN tb-OFF)

AUTO SEQ – PROCEED (IN PROG It on)

ACAS, pause pts **shaded in bold**, ● col indicates data recording (black = VTR on) (19:15)

Pt	X	Y	Z	PITCH	YAW	ROLL	●
40P	-544	-78	-133	201	306	210	
Δ	-18	+44	-3	-1	+4	+3	
41	-526	-122	-130	203	311	212	
Δ	+46	+27	+9	-3	-2	+7	
42	-572	-149	-139	213	313	222	
Δ	-22	-155	-26	+4	-6	-15	
43	-550	+6	-113	192	302	202	
Δ	+324	-27	-9	0	-38	+5	
44	-874	+33	-104	302	283	314	
Δ	+16	+56	+5	-1	-5	+4	
45	-890	-23	-109	308	289	319	
Δ	-286	+37	+10	+1	+31	+3	
46	-604	-60	-119	223	296	231	
Δ	+6	+96	+15	-2	+2	+12	
47	-610	-156	-134	235	307	243	
Δ	+60	+39	+16	-1	-5	+7	
48	-670	-195	-150	246	311	255	
Δ	-17	-103	-26	+2	-2	-13	
49	-653	-92	-124	237	299	247	
Δ	+294	-44	-19	-29	-48	-29	
50	-947	-48	-105	348	310	353	
Δ	+48	+52	+2	+1	-5	0	
51	-995	-100	-107	349	315	355	
Δ	-350	+63	+25	+10	+27	+18	
52	-645	-163	-132	297	307	307	
Δ	+355	+7	-19	-11	-21	-17	
53	-1000	-170	-113	337	313	348	
Δ	-13	-100	-9	0	+10	-5	
54	-987	-70	-104	338	302	349	
Δ	+326	+1	-2	-1	-23	-4	
55	-1313	-71	-102	349	323	4	
Δ	-48	+84	+1	0	-6	+10	
56	-1265	-155	-103	344	331	354	
Δ	+124	-6	-1	-9	-15	-4	
57	-1389	-149	-102	355	345	0	
Δ	-14	+53	+4	0	-3	-1	
58	-1375	-202	-106	355	348	1	
Δ	-170	-28	+1	+1	0	+1	
59P	-1220	-167	-147	354	321	0	
Δ	-50	-7	+13	-3	+1	0	



9. PORT ITVC BELLY TILE ACAS, SECTION 7

When AUTO SEQ READY It – on:

RHC

RATE – VERN (RATE MIN tb-ON)

A7U

√MUX 1 L ← MIDDECK

√DTV ← PL2

PAN/TILT to match ITVC view shown below

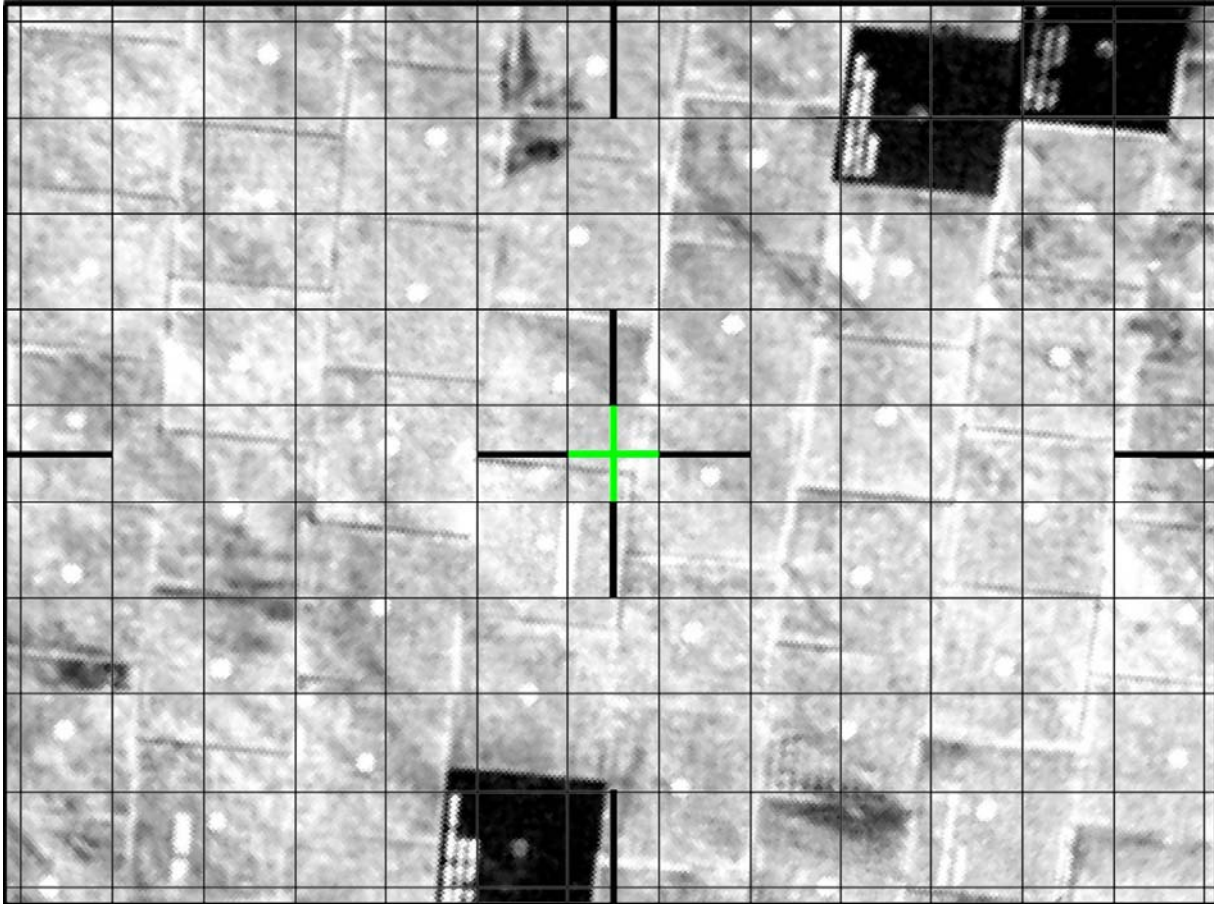

ITVC (85,-100)

√MCC to verify correct sensor view

Note PAN/TILT: _____, _____



FOCUS: 9 ft

VID OUT – not DTV

VID IN – not PL2

AUTO SEQ – PROCEED (IN PROG It on)

ACAS, pause pts **shaded in bold**, ● col indicates data recording (black = VTR on) (07:30)

Pt	X	Y	Z	PITCH	YAW	ROLL	●
59P Δ	-1220 -50	-167 -7	-147 +13	354 -3	321 +1	0 0	
60 Δ	-1170 +28	-160 -30	-160 +5	351 -14	320 -16	0 -5	
61 Δ	-1198 -182	-130 +6	-165 0	6 +1	336 0	4 +5	
62 Δ	-1016 +4	-136 +48	-165 +6	3 0	336 -5	359 0	
63 Δ	-1020 +175	-184 -32	-171 -10	3 -1	341 0	359 -9	
64 Δ	-1195 -14	-152 +48	-161 +4	7 -1	342 -3	8 +2	
65 Δ	-1181 -175	-200 +9	-165 +16	7 -1	345 +1	6 +18	
66P Δ	-1006 +12	-209 +76	-181 -44	2 +7	342 -17	347 +4	

10. PORT ITVC BELLY TILE ACAS, SECTION 8

When AUTO SEQ READY It – on:

RHC RATE – COARSE (RATE MIN tb-OFF)

A7U √DTV ← PL2
FOCUS: 13 ft

VID OUT – not DTV
VID IN – not PL2

AUTO SEQ – PROCEED (IN PROG It on)

ACAS, pause pts **shaded in bold**, ● col indicates data recording (black = VTR on) (12:15)

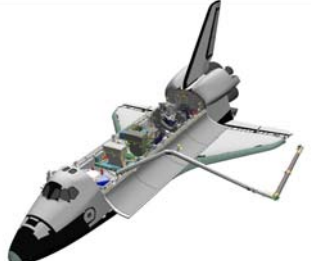
Pt	X	Y	Z	PITCH	YAW	ROLL	●
66P Δ	-1006 +12	-209 +76	-181 -44	2 +7	342 -17	347 +4	
67 Δ	-1018 +321	-285 -32	-137 -21	355 0	359 +6	345 -15	
68 Δ	-1339 -29	-253 +63	-116 +9	357 0	352 0	0 0	
69 Δ	-1310 -265	-316 +9	-125 +10	357 0	352 -7	0 +15	
70 Δ	-1045 +115	-325 +19	-135 -10	357 -2	0 -7	345 -15	
71 Δ	-1160 +173	-344 +10	-125 +15	357 0	6 +14	0 -1	
72 Δ	-1333 -14	-354 +61	-140 0	357 0	352 0	0 0	
73 Δ	-1319 -149	-415 -55	-140 -12	357 -6	352 -19	0 -9	
74 Δ	-1170 +157	-360 +115	-128 +9	1 1	11 11	8 13	
75 Δ	-1327 -12	-475 -20	-137 0	0 0	0 0	355 0	
76 Δ	-1315 +8	-455 +82	-137 +178	0 -7	0 +17	355 +73	
77P Δ	-1323 0	-537 0	-315 0	346 0	348 0	282 0	

11. RECONFIGURE FOR OBSS LDRI/IDC RCC SURVEY – PORT

When AUTO SEQ IN PROG It – off:

LCC/PGSC sel 'Stop Scan'
L10(VTR) STOP pb – push (no red ●)
 BRAKES – ON (tb-ON)

Verify mnvr to Port LDRI ACAS, Point 114P complete:

	X	Y	Z	PITCH	YAW	ROLL	PL ID
√	-1323	-537	-315	346	348	282	5
	SY	SP	EP	WP	WY	WR	
√	+80.9	+49.1	-50.2	+5.9	+0.6	-87.1	

SM 94 PDRS CONTROL

PL ID – ITEM 3 +2 EXEC
INIT ID – ITEM 24 +2 EXEC
AUTO MODES – ITEM 13 +5 EXEC
START PT – ITEM 17 +1 1 4 EXEC

RMS EE CREW CABIN SURVEY (50 min)

NOTE

Assumed starting posn Pre-Cradle.

Daylight required while survey data being taken.

Uplink of a new PLID required.

Coarse rates allowed within 10 ft since Coarse rates set to calculated vernier rates. Vernier rates set to required scan rate

1. SETUP

SM 94 PDRS CONTROL

√ PL ID, ITEM 3: 0

√ INIT ID, ITEM 24: 0

PRE-CRADLE posn:

	X	Y	Z	PITCH	YAW	ROLL	PL ID
√	-1261	-146	-551	5	2	0	0
	SY	SP	EP	WP	WY	WR	
√	0.0	+25.0	-25.0	+5.0	0	0	

SM 94 PDRS CONTROL

AUTO MODES – ITEM 13 +2 +7 +3 +8 EXEC

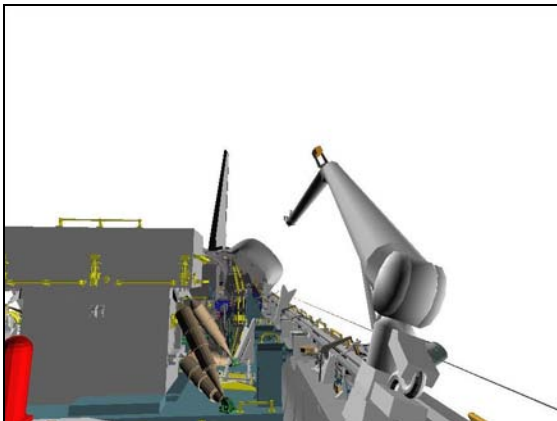

CCTV A (5,10)

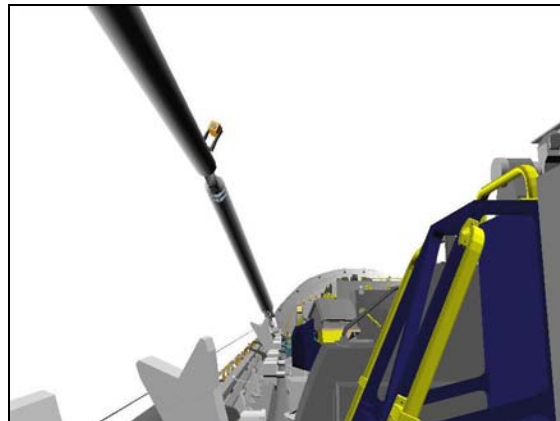

CCTV B (0,10)

2. MNVR TO STBD SURVEY ACAS START

SM 94 PDRS CONTROL

END POS – ITEM 18 -5 0 1 +1 5 1 -5 8 6 EXEC

ATT – ITEM 21 +2 8 1 +2 5 +3 0 7 EXEC

CMD CK – ITEM 25 EXEC (GOOD)

RHC

RATE – VERN (RATE MIN tb-ON)

BRAKES – OFF (tb-OFF)

MODE – OPR CMD, ENTER (READY It on)

┌ After PROCEED, if motion no longer apparent but POR within
┌ 1 in/1 deg and IN PROG It – on:
┌ AUTO SEQ – STOP

AUTO SEQ – PROCEED (IN PROG It on)

When AUTO SEQ IN PROG It – off:
BRAKES – ON (tb-ON)

STBD SURVEY ACAS START posn:

	X	Y	Z	PITCH	YAW	ROLL	PL ID
√	-501	+151	-586	281	25	307	0
	SY	SP	EP	WP	WY	WR	
√	-119.7	+58.1	-82.9	-109.8	-11.2	+82.1	

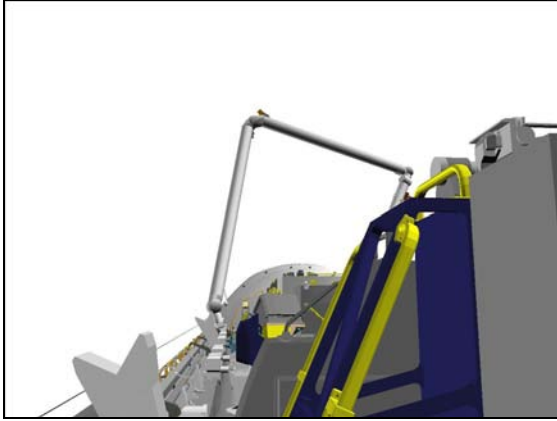

CCTV B (5,10)

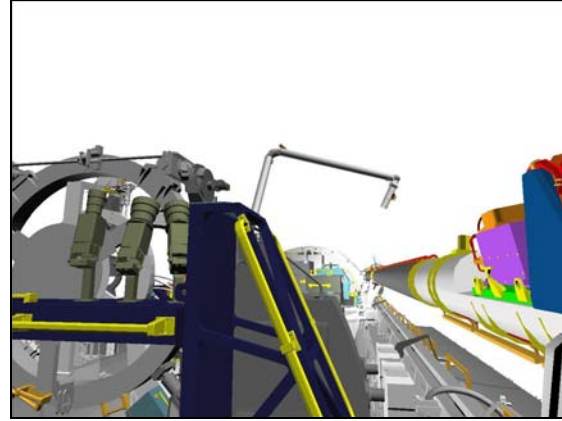

CCTV C (-10,10)

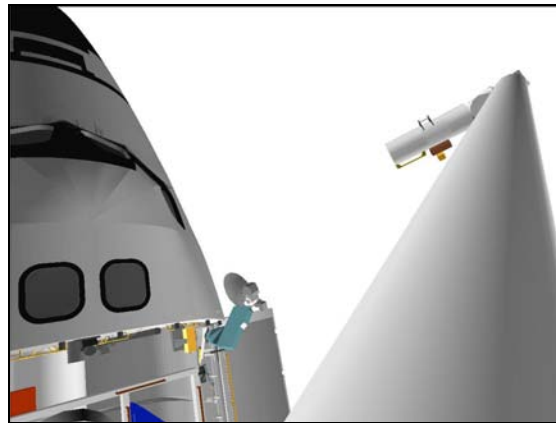

ELBOW (-30,-25)

3. INHIBIT NOSE JETS
 O14:F, Pri RJDA LOGIC,DRIVER (eight) – ON
 O15:F, √Pri RJDF LOGIC,DRIVER (eight) – OFF
 O16:F
 A6U DAP: A14/AUTO/ALT (Tail Only)

NOTE

Expect DAP RECONFIG message after
FRCS manifold 5 status overridden to close

GNC 23 RCS

- RCS FWD – ITEM 1 EXEC (*)
 MANF VLVS OVRD 1 – ITEM 40 EXEC (CL)
 2 – ITEM 41 EXEC (CL)
 3 – ITEM 42 EXEC (CL)
 4 – ITEM 43 EXEC (CL)
 5 – ITEM 44 EXEC (CL)

4. STBD SURVEY ACAS

NOTE

Lighting is critical for survey data. Wait for daylight prior to Auto sequence proceed

SM 94 PDRS CONTROL

PL ID – ITEM 3 +5 EXEC
INIT ID – ITEM 24 +5 EXEC

SM 95 PDRS OVERRIDE

LOADED RATE – ITEM 14 EXEC (*)

STBD SURVEY ACAS START posn:

	X	Y	Z	PITCH	YAW	ROLL	PL ID
√	-501	+151	-586	281	25	307	5
	SY	SP	EP	WP	WY	WR	
√	-119.7	+58.1	-82.9	-109.8	-11.2	+82.1	

A7U

√DTV ← RMS

CCTV – RMS WRIST, ZOOM: 20.0 HFOV

L10(VTR)

REC pb – push, hold

PLAY pb – push, simo (red ● on LCD)

RHC

√RATE – VERN (RATE MIN tb-ON)

BRAKES – OFF (tb-OFF)

MODE – AUTO 1, ENTER (READY It on)

* If unable to enter AUTO mode (no AUTO READY It): *

* √Joint angles and adjust as reqd *

SM 94 PDRS CONTROL

√START PT, ITEM 17: 78

SM 169 PDRS STATUS

Monitor ACAS progress



Stbd EE ACAS Clearance Views	Cameras
RMS-to-Fwd Bulkhead	A,D
RMS overview	B,C

NOTE

Clearance between Upper Boom and Forward Bulkhead is 21.6 inches at point 79

AUTO SEQ – PROCEED (IN PROG It on)

ACAS, pause pts **shaded in bold**, ● col indicates data recording (black = VTR on): (08:55)

Pt	X	Y	Z	PITCH	YAW	ROLL	●
78P	-501	+151	-586	281	25	307	
79	-249	+91	-502	270	24	305	
80	-247	+30	-517	271	7	305	
81	-493	+109	-638	281	17	306	
82	-533	+38	-645	281	4	317	
83	-246	+16	-519	270	7	305	
84	-417	-9	-612	288	1	315	
85P	-536	-4	-638	281	359	318	

When AUTO SEQ IN PROG It – off:
BRAKES – ON (tb-ON)

L10(VTR) STOP pb – push (no red ●)



CCTV B (5,10)

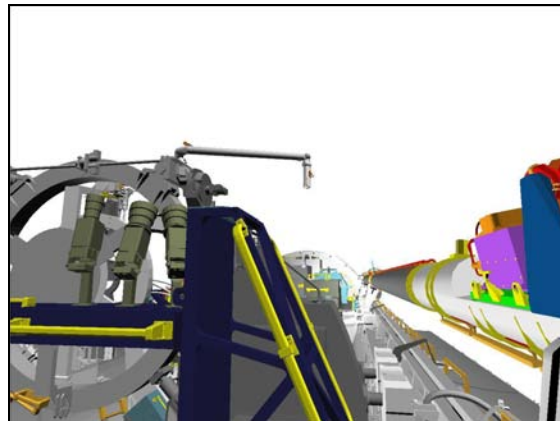

CCTV C (-10,10)



EE HFOV: 20.0

5. MNVR TO PORT SURVEY ACAS START

SM 94 PDRS CONTROL

PL ID – ITEM 3 +0 EXEC
INIT ID – ITEM 24 +0 EXEC

RHC √RATE – VERN (RATE MIN tb-ON)
BRAKES – OFF (tb-OFF)

MODE – AUTO 2, ENTER (READY It on)

- * If unable to enter AUTO mode (no AUTO READY It): *
- * √Joint angles and adjust as reqd *

SM 94 PDRS CONTROL

√START PT, ITEM 17: 148

SM 169 PDRS STATUS

Monitor ACAS progress

AUTO SEQ – PROCEED (IN PROG It on)

ACAS, pause pts **shaded in bold**, ● col indicates data recording (black = VTR on): (03:10)

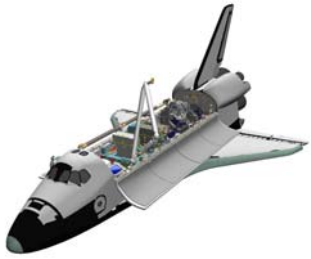
Pt	X	Y	Z	PITCH	YAW	ROLL	●	
148P	-536	-4	-638	281	359	318		
149	-761	+32	-651	259	359	17		
150	-1042	-345	-580	323	24	333		
151P	-553	-230	-551	257	314	288		

When AUTO SEQ IN PROG It – off:
BRAKES – ON (tb-ON)

Verify PORT SURVEY ACAS START posn:

	X	Y	Z	PITCH	YAW	ROLL	PL ID
√	-553	-230	-551	257	314	288	0
	SY	SP	EP	WP	WY	WR	
√	+138.2	+119.0	-123.3	-97.8	+26.7	-179.8	

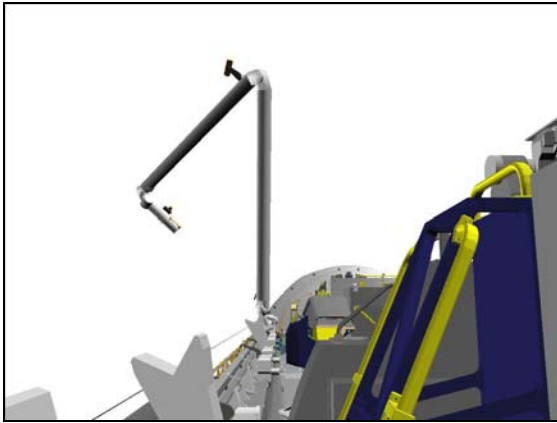

CCTV B (0,10)



CCTV D (70,25)



EE HFOV: 20.0

6. PORT SURVEY ACAS

NOTE

Lighting is critical for survey data. Wait for daylight prior to Auto sequence proceed

SM 94 PDRS CONTROL

PL ID – ITEM 3 +5 EXEC
INIT ID – ITEM 24 +5 EXEC

L10(VTR) REC pb – push, hold
PLAY pb – push, simo (red ● on LCD)

RHC √RATE – VERN (RATE MIN tb-ON)
BRAKES – OFF (tb-OFF)

MODE – AUTO 3, ENTER (READY lt on)

- * If unable to enter AUTO mode (no AUTO READY lt): *
- * √Joint angles and adjust as reqd *

SM 94 PDRS CONTROL

√START PT, ITEM 17: 86



SM 169 PDRS STATUS

Monitor ACAS progress

Port EE ACAS Clearance Views	Cameras
RMS-to-Fwd Bulkhead	A,D
RMS overview	B

AUTO SEQ – PROCEED (IN PROG It on)

ACAS, pause pts **shaded in bold**, ● col indicates data recording (black = VTR on): (06:35)

Pt	X	Y	Z	PITCH	YAW	ROLL	●	
86P	-553	-230	-551	257	314	288		
87	-279	-148	-473	259	313	271		
88	-514	-212	-591	268	313	291		
89	-582	-153	-610	268	313	277		
90	-524	-157	-610	268	313	277		
91P	-276	-146	-473	259	313	292		

When AUTO SEQ IN PROG It – off:
BRAKES – ON (tb-ON)

L10(VTR) STOP pb – push (no red ●)

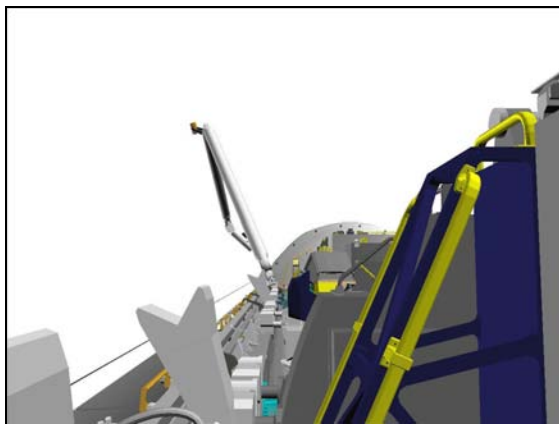

CCTV B (0,5)

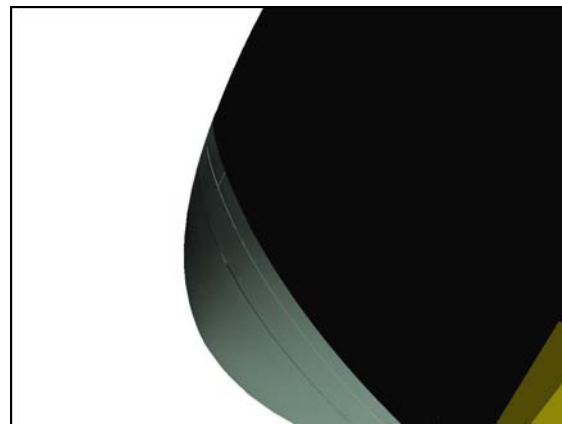

EE HFOV: 20.0

7. MNVR TO PRE-CRADLE

SM 95 PDRS OVERRIDE

LOADED RATE – ITEM 14 EXEC (no *)

SM 94 PDRS CONTROL

PL ID – ITEM 3 +0 EXEC

INIT ID – ITEM 24 +0 EXEC

RHC √RATE – VERN (RATE MIN tb-ON)
 BRAKES – OFF (tb-OFF)
 MODE – AUTO 4, ENTER (READY It on)

- * If unable to enter AUTO mode (no AUTO READY It): *
- * √Joint angles and adjust as reqd *

SM 94 PDRS CONTROL

√START PT, ITEM 17: 152

SM 169 PDRS STATUS

Monitor ACAS progress

AUTO SEQ – PROCEED (IN PROG It on)

ACAS, pause pts **shaded in bold**, ● col indicates data recording (black = VTR on): (03:20)

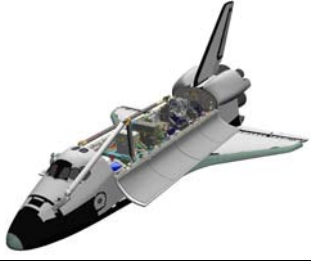
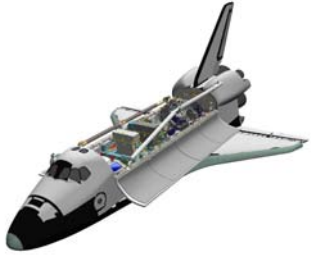
Pt	X	Y	Z	PITCH	YAW	ROLL	●
152P	-276	-146	-473	259	313	292	
153	-881	-572	-547	263	32	9	
154P	-1261	-146	-551	5	2	0	

When AUTO SEQ IN PROG It – off:
 BRAKES – ON (tb-ON)

PRE-CRADLE posn:

	X	Y	Z	PITCH	YAW	ROLL	PL ID
√	-1261	-146	-551	5	2	0	0
	SY	SP	EP	WP	WY	WR	
√	0.0	+25.0	-25.0	+5.0	0	0	

A7U PORT RMS CAMERA – ELBOW

8. ENABLE VERN NOSE JETS

GNC 23 RCS

- √RCS FWD – ITEM 1 EXEC (*)
- MANF VLVS OVRD 1 – ITEM 40 EXEC (OP)
- 2 – ITEM 41 EXEC (OP)
- 3 – ITEM 42 EXEC (OP)
- 4 – ITEM 43 EXEC (OP)
- 5 – ITEM 44 EXEC (OP)

A6U DAP: VERN(ALT)

O14:F, Pri RJDA LOGIC,DRIVER (eight) – OFF
 O15:F, RJDA 1A L2/R2 DRIVER – ON
 O16:F

CONTINGENCY STS-125 OPS

SJ POISED FOR CAPTURE	FS 3-2
STS-125 GRAPPLE.....	FS 3-6
ATTITUDE HOLD/EVA POSITION.....	FS 3-13
MNVR TO PRE-CRADLE	FS 3-19

CONTINGENCY
STS-125 OPS

SJ POISED FOR CAPTURE

I

- A7U 1. SETUP
 CCTV – perform PAN/TILT RESET
 – fully zoom out for SJ pictures
 – RMS WRIST, zoom 34.0 HFOV
 focus 5 ft
 Maintain eyepoint ~18 in when using grapple overlay

MON 1	C (D)
MON 2	Elbow (EE)

SM 94 PDRS CONTROL

- √PL ID, ITEM 3: 0
- √INIT ID, ITEM 24: 0

2. SJ MNVR TO POISED FOR CAPTURE

- PARAM – Joint Angle
 If SINGLE MODE available:
 RATE – as reqd (VERN within 10 ft)
 BRAKES – OFF (tb-OFF)
 MODE – best available

Mnvr to POISED FOR CAPTURE posn:

	SY	SP	EP	WP	WY	WR	
Pre-cradle	0.0	+25.0	-25.0	+5.0	0.0	0.0	
1: SP +		+111.2					*
2: EP -			-122.7				*
3: SY -	-124.7						
4: WP +				+85.4			
5: WY +					+11.0		
6: WR -						-103.7	
Poised for Capture	-124.7	+111.2	-122.7	+85.4	+11.0	-103.7	
	X	Y	Z	PITCH	YAW	ROLL	PL ID
	-569	-26	-746	90	0	0	0

* Expect SING light

- If SINGLE MODE:
 BRAKES – ON (tb-ON)
 MODE – not DIRECT

- PARAM – PORT TEMP
 JOINT – CRIT TEMP

- If SINGLE MODE available:
SM 94 PDRS CONTROL
 PL ID, ITEM 3 +3 EXEC
 INIT ID, ITEM 24 +3 EXEC

Review STS-400 END EFFECTOR CUE CARD

CONTINGENCY STS-125 OPS

Step 1:

Drive SP+ (for 86.2°)
From +25.0° to +111.2°

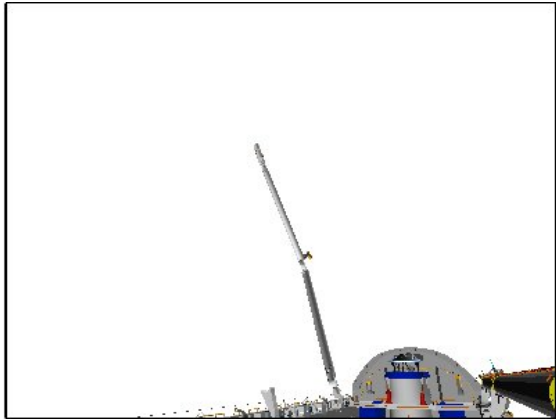

CCTV C (-25,25)

Step 2:

Drive EP- (for 97.7°)
From -25.0° to -122.7°



CCTV C (-25,25)

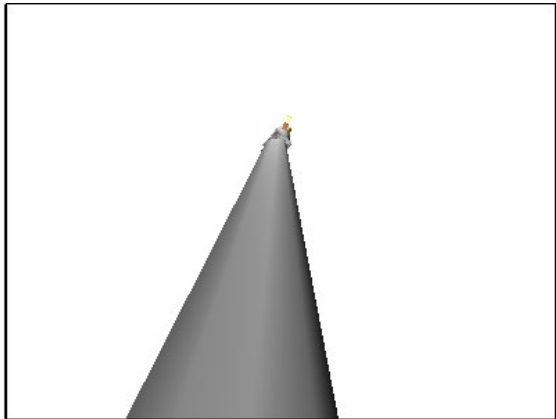

ELBOW (0,-15)

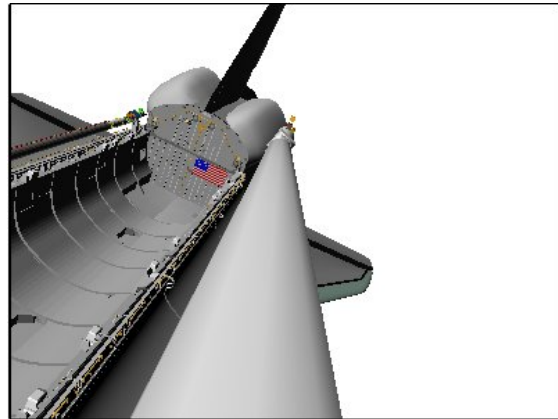

ELBOW (0,-15)

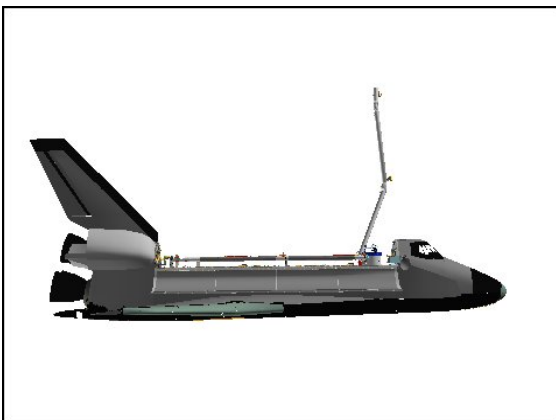

BIRD'S EYE

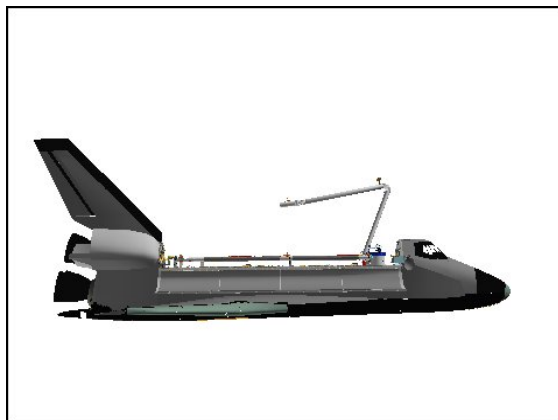

BIRD'S EYE

Step 3:

Drive SY- (for 124.7°)
From 0.0° to -124.7°



CCTV C (-25,25)

Step 4:

Drive WP+ (for 80.4°)
From +5.0° to +85.4°



CCTV C (-25,25)

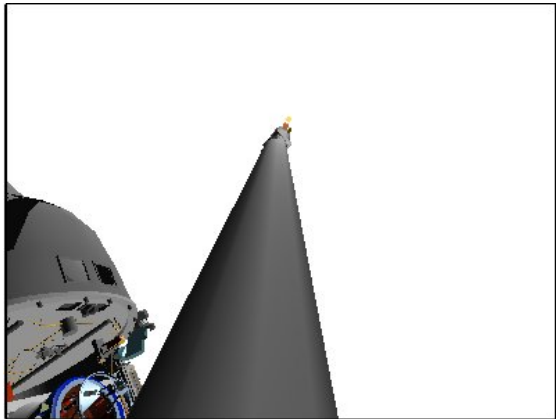

ELBOW (0,-15)

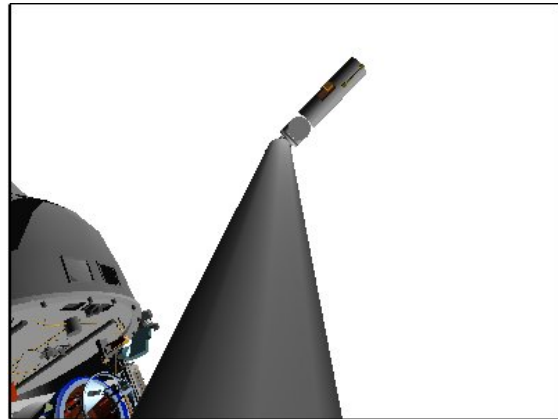

ELBOW (0,-15)

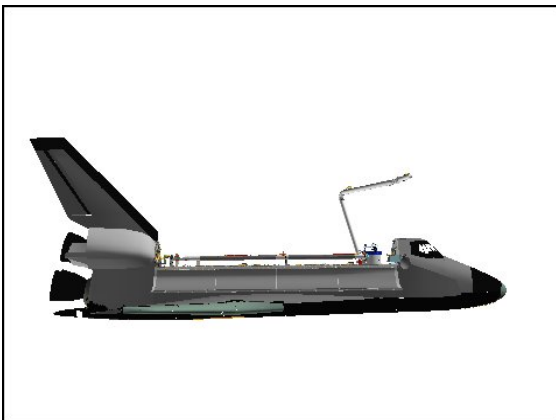

BIRD'S EYE

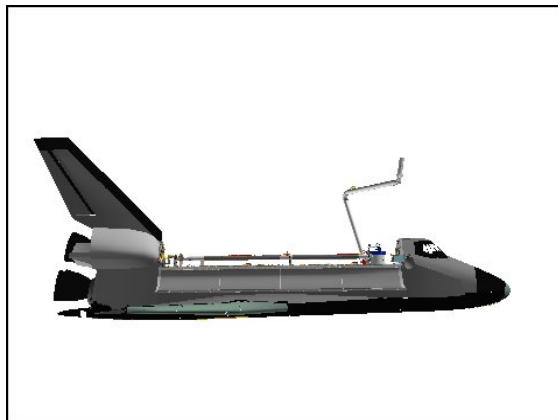

BIRD'S EYE

Step 5:

Drive WY+ (for 11.0°)
From 0.0° to +11.0°

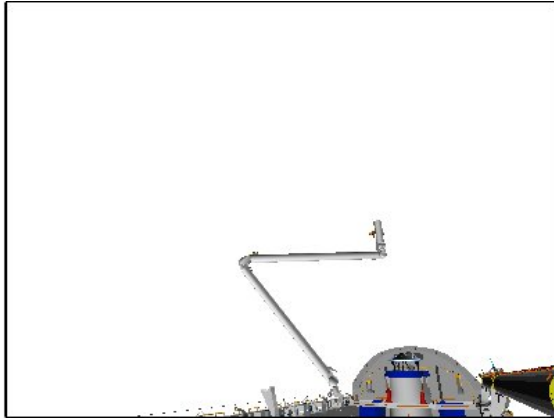

CCTV C (-25,25)

Step 6:

Drive WR- (for 103.7°)
From 0.0° to -103.7°

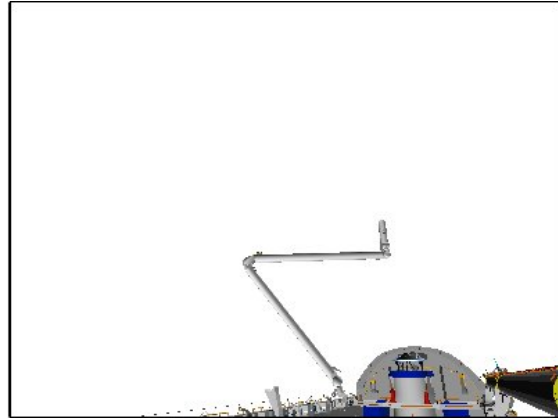

CCTV C (-25,25)

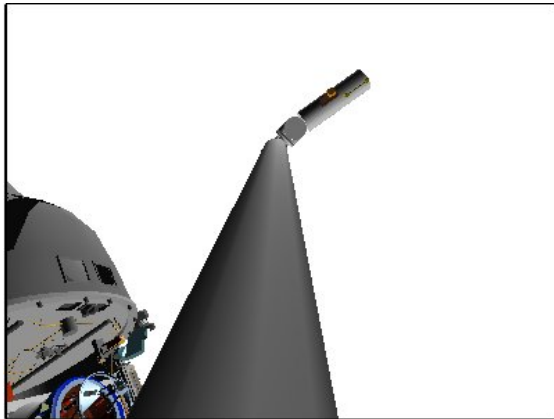

ELBOW (0,-15)

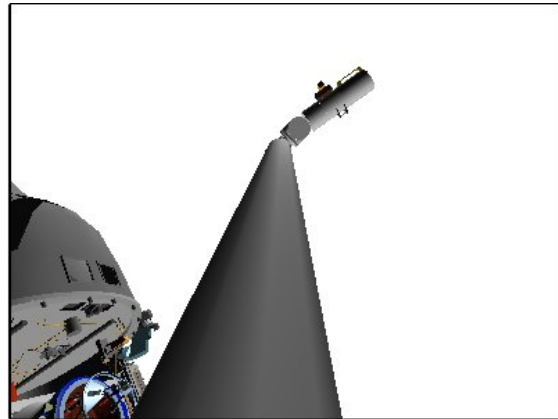

ELBOW (0,-15)

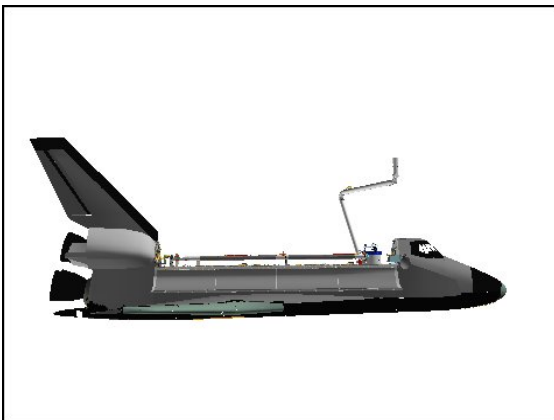

BIRD'S EYE

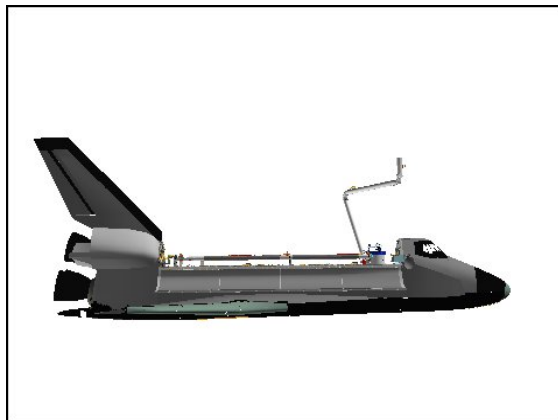

BIRD'S EYE

SJ STS-125 GRAPPLE

1. SETUP

CCTV – config for grapple

MON 1	B (C)
MON 2	Elbow → EE

Verify at POISED FOR CAPTURE posn:

X	Y	Z	PITCH	YAW	ROLL	PL ID
-598	-132	-730	360	0	191	3
SY	SP	EP	WP	WY	WR	
-124.7	+111.2	-122.7	+85.4	+11.0	-103.7	

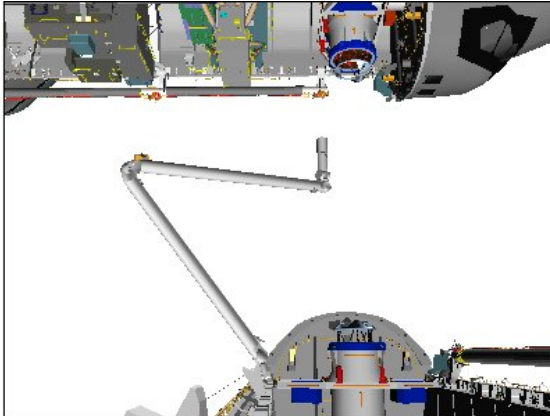

CCTV B (0,15)

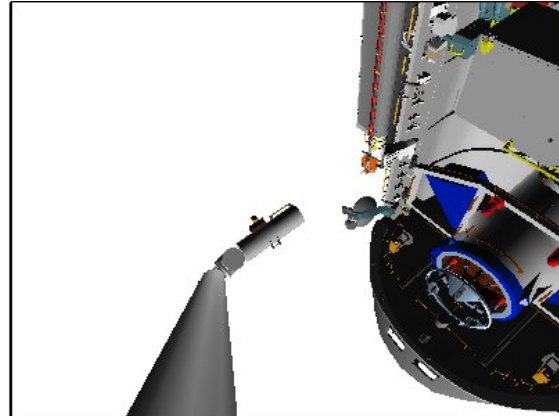

ELBOW (10,5)

2. SJ MNVR TO STS-125 PRE-GRAPPLE

PARAM – Joint Angle

If SINGLE MODE available:

√RATE – VERN (RATE MIN tb-ON)

BRAKES – OFF (tb-OFF)

MODE – best available

Mnvr to STS-125 PRE-GRAPPLE posn:

	SY	SP	EP	WP	WY	WR	
Poised for Capture	-124.7	+111.2	-122.7	+85.4	+11.0	-103.7	
1: SY +	-118.0						
2: SP +		+113.7					
3: EP +			-122.3				
4: WP –				+77.2			
5: WY –					-1.2		
6: WR +						-6.0	
STS-125 Pre-Grapple	-118.0	+113.7	-122.3	+77.2	-1.2	-6.0	
	X	Y	Z	PITCH	YAW	ROLL	PL ID
	-687	+6	-761	11	270*	191	3

*display singularity

If SINGLE MODE:

BRAKES – ON (tb-ON)

MODE – not DIRECT

Step 1:

Drive SY+ (for 6.7°)
From -124.7° to -118.0°

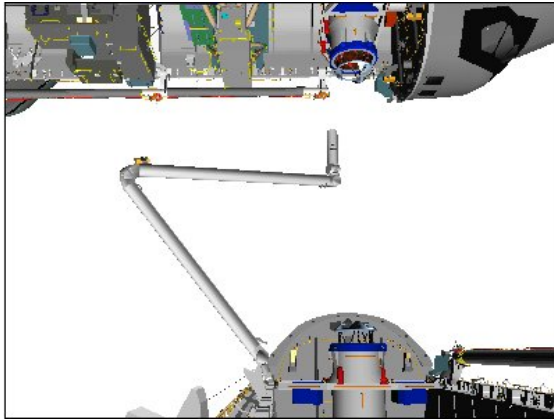

CCTV B (0,15)

Step 2:

Drive SP+ (for 2.5°)
From +111.2° to +113.7°

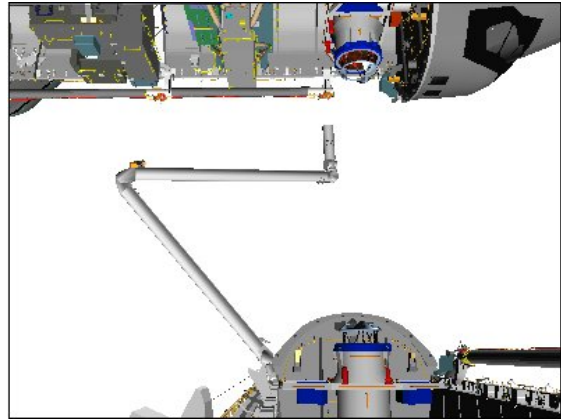

CCTV B (0,15)

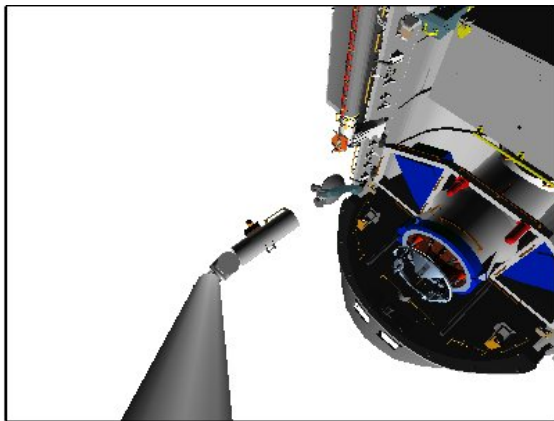

ELBOW (10,5)

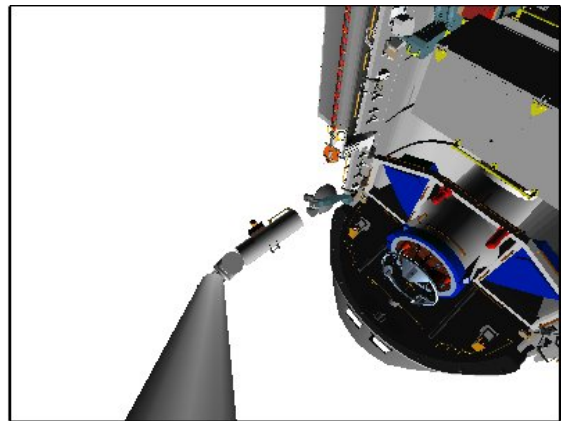

ELBOW (10,5)

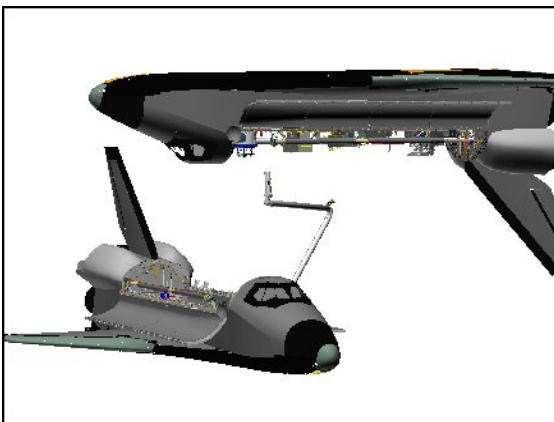

BIRD'S EYE

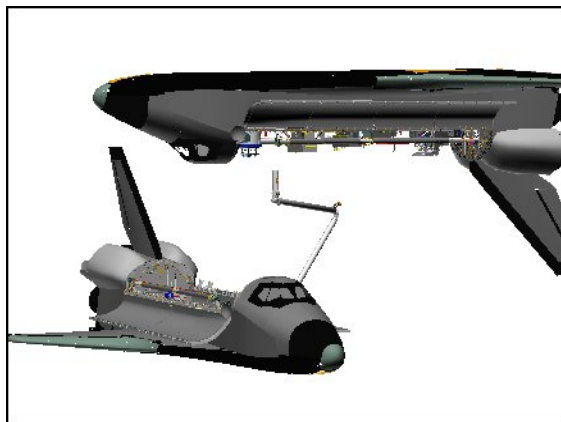

BIRD'S EYE

Step 3:

Drive EP+ (for 0.4°)
From -122.7° to -122.3°

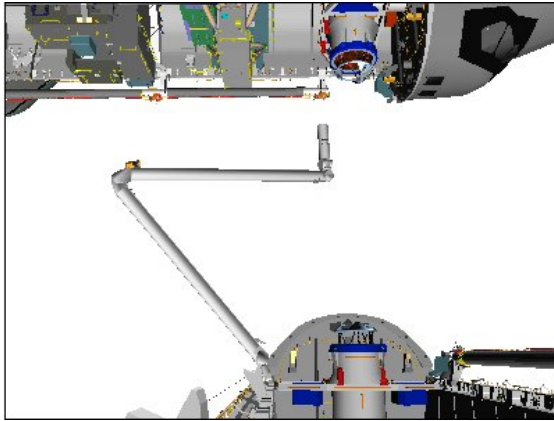

CCTV B (0,15)

Step 4:

Drive WP- (for 8.2°)
From +85.4° to +77.2°

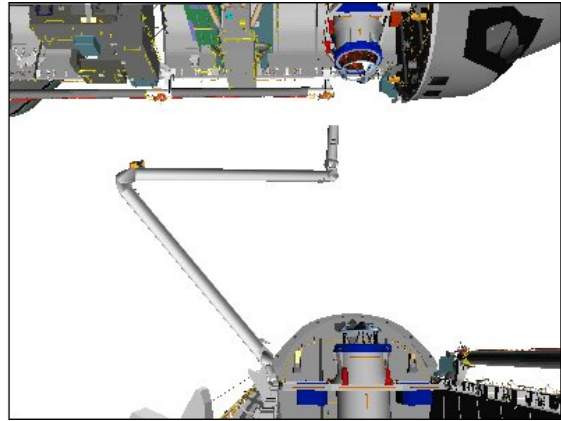

CCTV B (0,15)

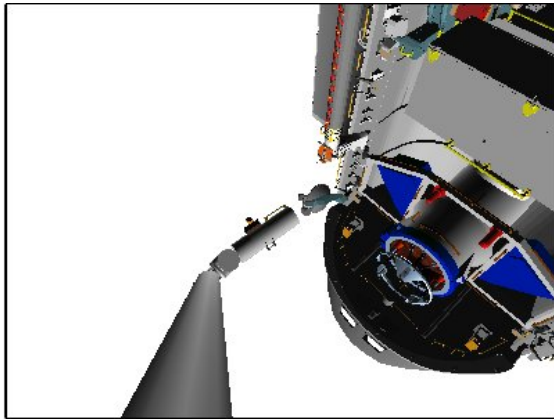

ELBOW (10,5)

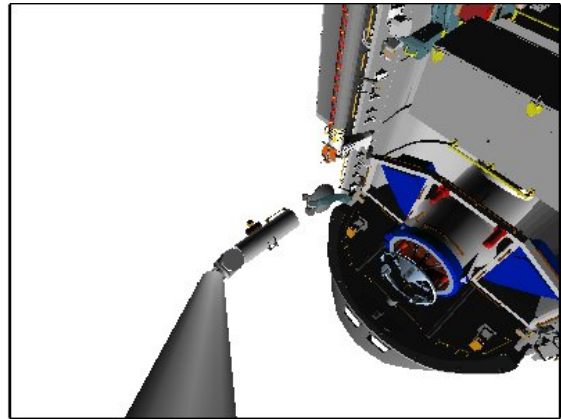

ELBOW (10,5)

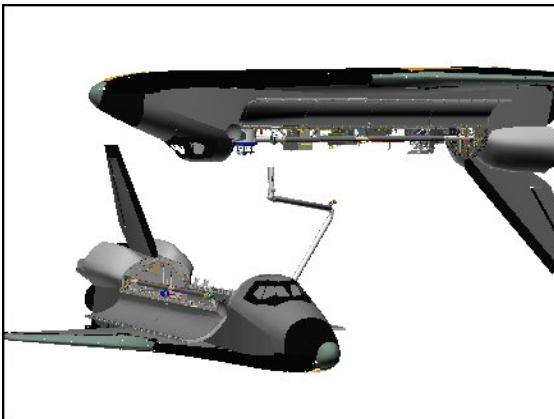

BIRD'S EYE

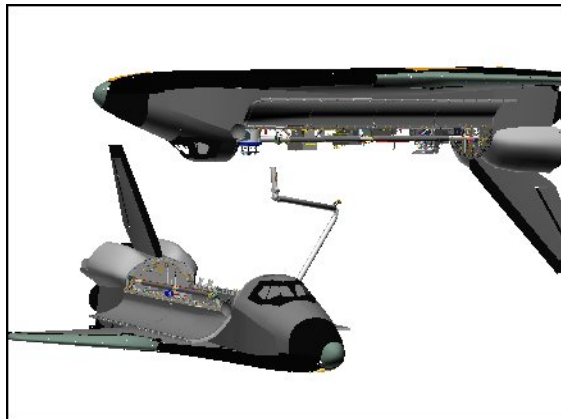

BIRD'S EYE

Step 5:

Drive WY- (for 12.2°)
From +11.0° to -1.2°

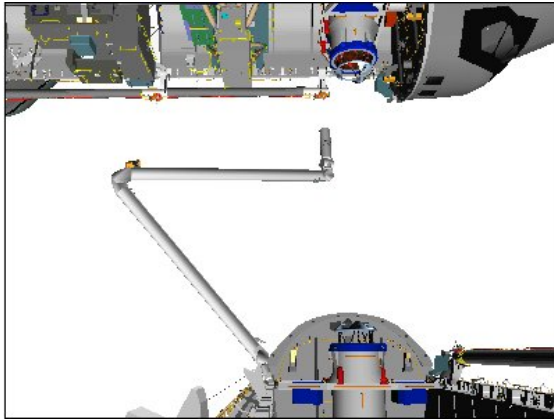

CCTV B (0,15)

Step 6:

Drive WR+ (for 97.7°)
From -103.7° to -6.0°

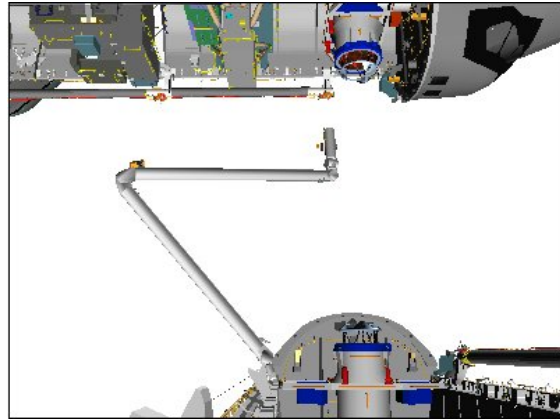

CCTV B (0,15)

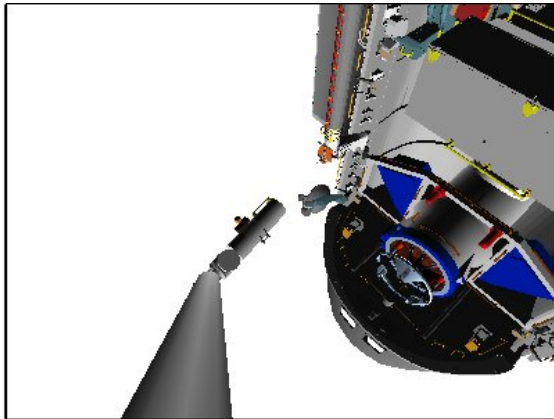

ELBOW (10,5)

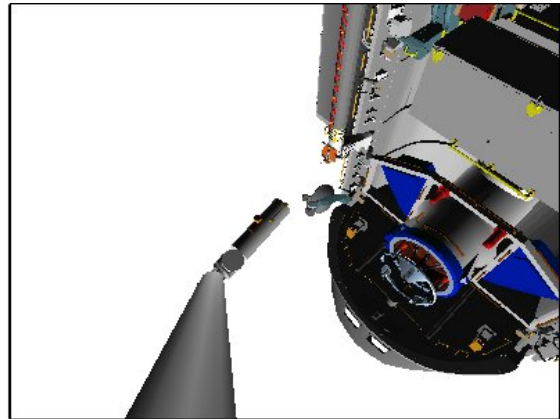

ELBOW (10,5)

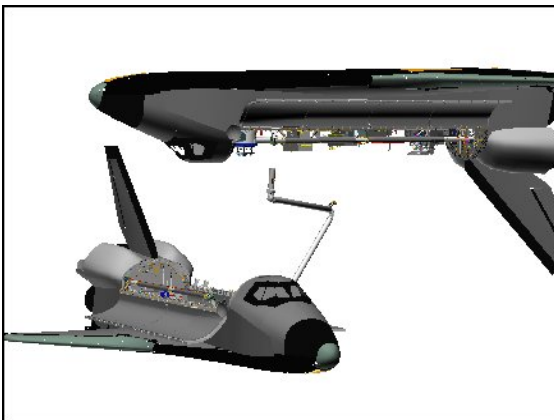

BIRD'S EYE

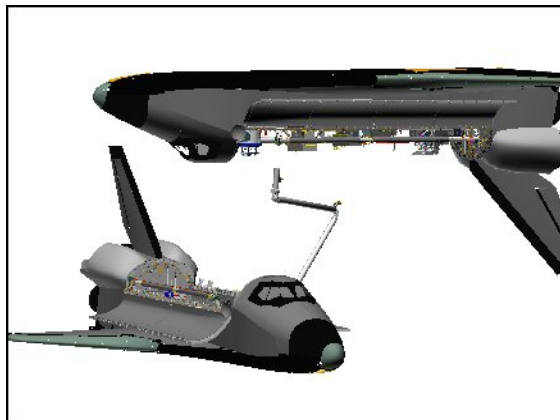

BIRD'S EYE

3. SJ MNVR TO STS-125 GRAPPLE

If SINGLE MODE available:

√RATE – VERN (RATE MIN tb-ON)

BRAKES – OFF (tb-OFF)

MODE – best available

Verify orbiter and SRMS GO for grapple

EE MODE – AUTO

DAP: FREE

Drive joints per STS-125 SJ GRAPPLE – WRIST CCTV OVERLAY and diagram until EE within grapple envelope

STS-125 ORBITER SJ GRAPPLE

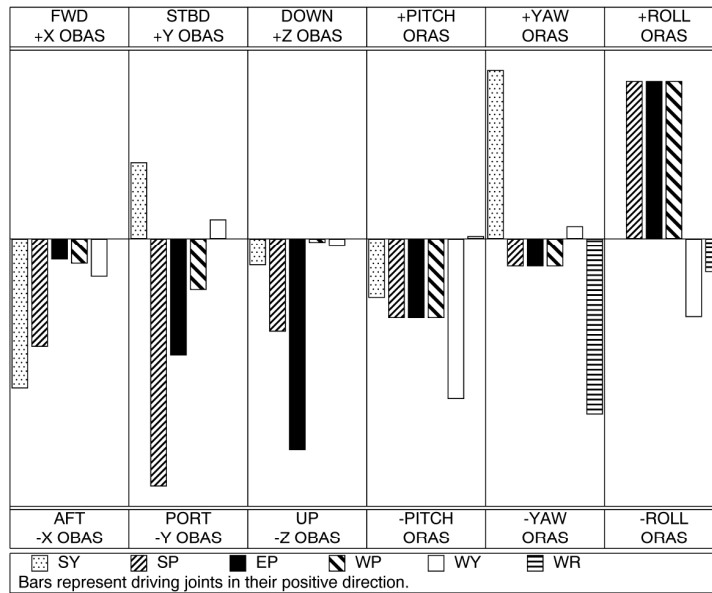

To get:	Drive:	To get:	Drive:
+X (fwd)	-SY, -SP	+PITCH	-WY, -WP
+Y (stbd)	-SP, -EP	+YAW	-WR, +SY
+Z (down)	-EP, -SP	+ROLL	+WP, +EP

Driving:	Results In:	Driving:	Results In:
+SY	-X (aft), +YAW	+WP	-Y (port), +ROLL
+SP	-Y (port), +ROLL	+WY	-X (aft), -PITCH
+EP	-Z (up), +ROLL	+WR	-YAW

ΔSY	ΔSP	ΔEP	ΔWP	ΔWY	ΔWR
-0.5	-4.8	+14.9	-10.2	+0.1	-0.4

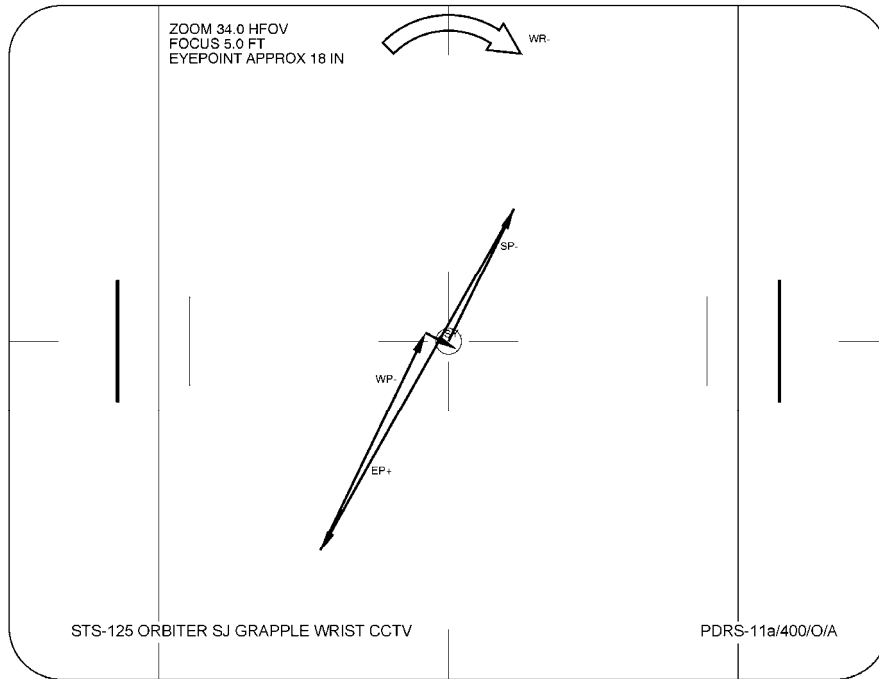

4. STS-125 GRAPPLE

CAUTION
Monitor EE tb timing to prevent EE motor burnout

SM 169 PDRS STATUS

EE CAPTURE sw – depress (mom)

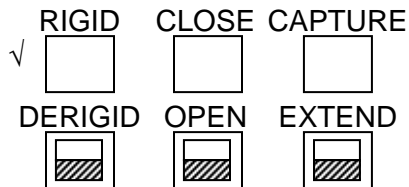

CRITICAL TIMES (28 sec total):

CAPTURE tb – gray, then
CLOSE tb – gray, 3 sec max, then
RIGID tb – gray, 25 sec max

- * If manual grapple reqd: *
- * EE MODE – MAN *
- * CAPTURE sw – depress (hold until CLOSE tb-gray, 3 sec max) *
- * MAN CONTR – RIGID (hold until RIGID tb-gray, 25 sec max) *

EE MODE – OFF
BRAKES – ON (tb-ON)
MODE – not DIRECT

DAP: as reqd

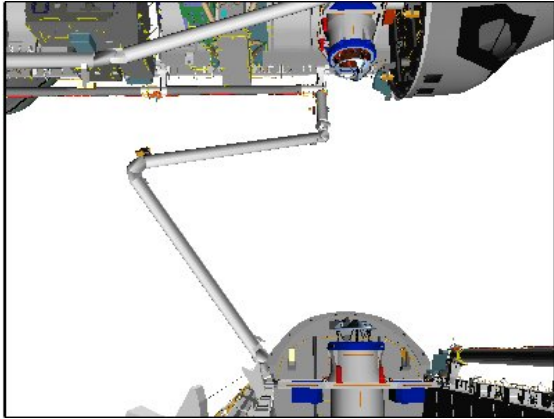

CCTV B (0,15)

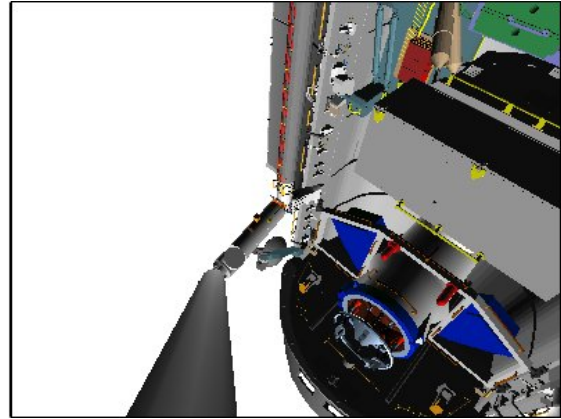

ELBOW (10,5)

Verify at STS-125 GRAPPLE posn:

X	Y	Z	PITCH	YAW	ROLL	PL ID
-676	+5	-820	0	270*	180	3
SY	SP	EP	WP	WY	WR	
-118.4	+108.9	-107.4	+67.1	-1.1	-6.3	

*display singularity

SJ STS-125 ATTITUDE HOLD/EVA POSITION

I

1. SETUP

MON 1	A (D)
MON 2	C (B)

SM 94 PDRS CONTROL

√ PL ID, ITEM 3: 3

√ INIT ID, ITEM 24: 3

Verify at STS-125 GRAPPLE posn:

X	Y	Z	PITCH	YAW	ROLL	PL ID
-676	+5	-820	0	270*	180	3
SY	SP	EP	WP	WY	WR	
-118.4	+108.9	-107.4	+67.1	-1.1	-6.3	

*display singularity

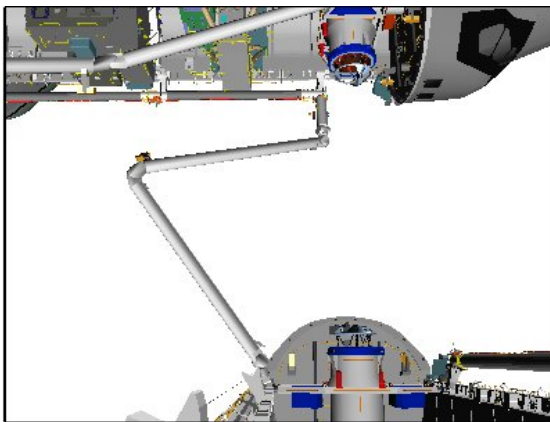

CCTV B (0,15)

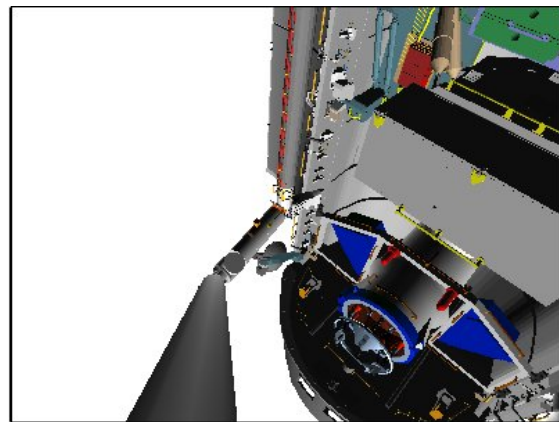

ELBOW (10,5)

2. SJ MNVR TO ATTITUDE HOLD/EVA POSITION

If SINGLE MODE available:

RATE – VERN (RATE MIN tb-ON)

BRAKES – OFF (tb-OFF)

MODE – best available

DAP: FREE

Mnvr to ATTITUDE HOLD/EVA posn:

STS-125
Grapple

- 1: EP +
- 2: SP –
- 3: WP –
- 4: WR –
- 5: WY –
- 6: EP +
- 7: SY +

SY	SP	EP	WP	WY	WR	
-118.4	+108.9	-107.4	+67.1	-1.1	-6.3	
		-57.0				
	+58.6					
			+33.9			
					-47.4	
				-12.8		
		-29.9				
-63.8						
-63.8	+58.6	-29.9	+33.9	-12.8	-47.4	
X	Y	Z	PITCH	YAW	ROLL	PL ID
-878	-1	-964	0	1	180	3

If SINGLE MODE:
BRAKES – ON (tb-ON)
MODE – not DIRECT

PARAM – PORT TEMP
JOINT – CRIT TEMP

DAP: as reqd

|

Step 1:

Drive EP+ (for 50.4°)
From -107.4° to -57.0°

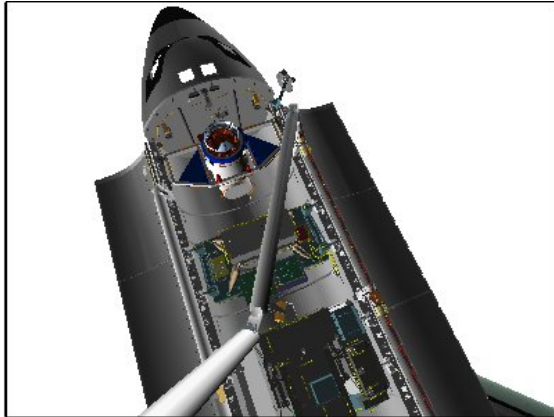

CCTV A (60,60)

Step 2:

Drive SP- (for 50.3°)
From +108.9° to +58.6°



CCTV A (90,120)

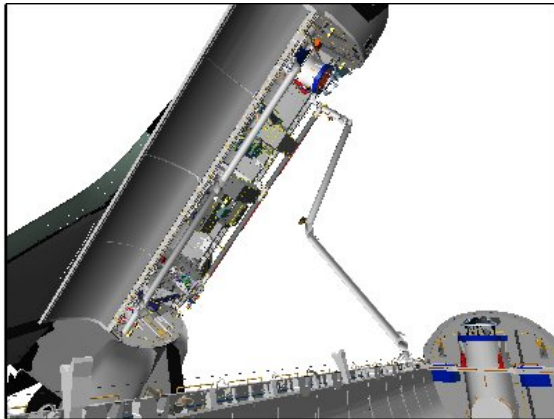

CCTV C (-35,20)

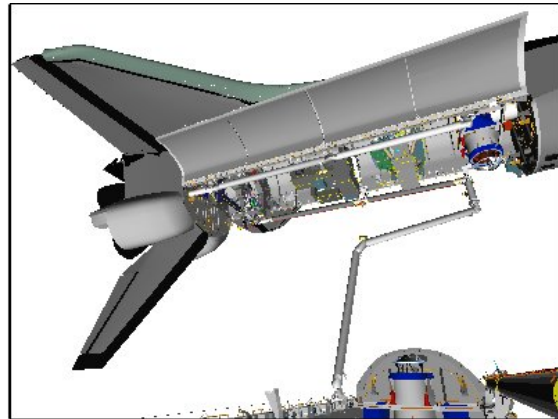

CCTV C (-25,25)

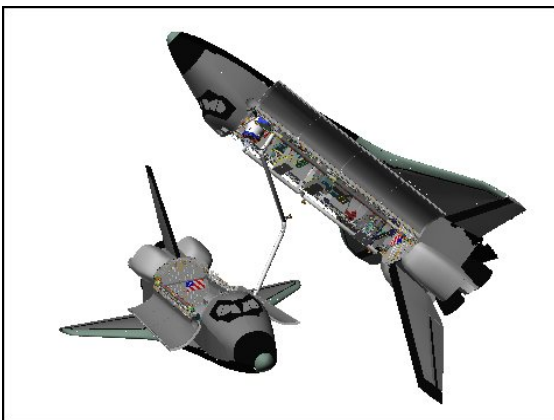

BIRD'S EYE

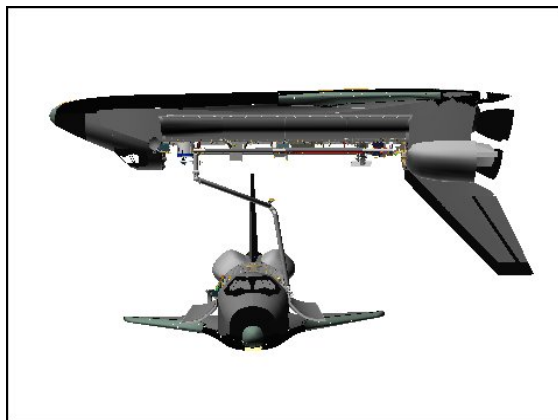

BIRD'S EYE

Step 3:

Drive WP- (for 33.2°)
From +67.1° to +33.9°

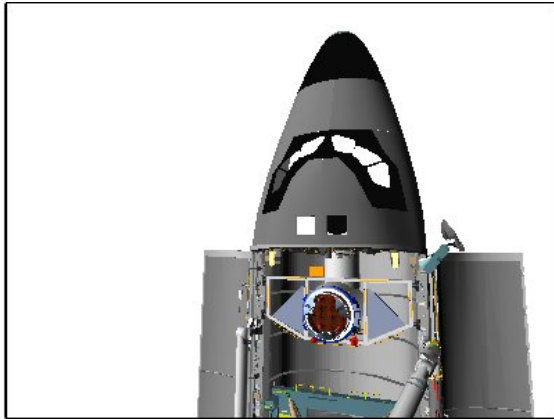

CCTV D (100,125)

Step 4:

Drive WR- (for 41.1°)
From -6.3° to -47.4°

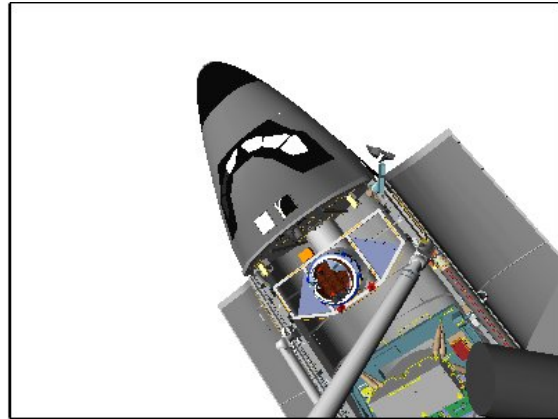

CCTV D (100,110)

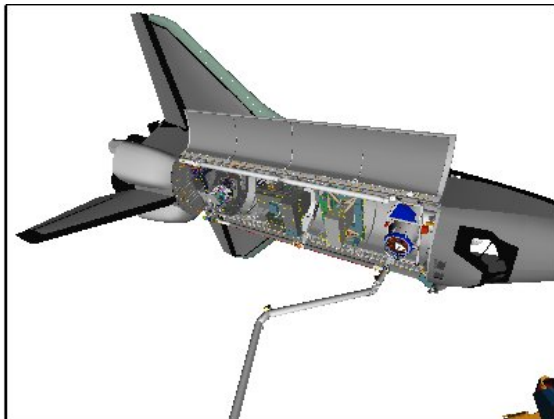

CCTV C (-10,35)

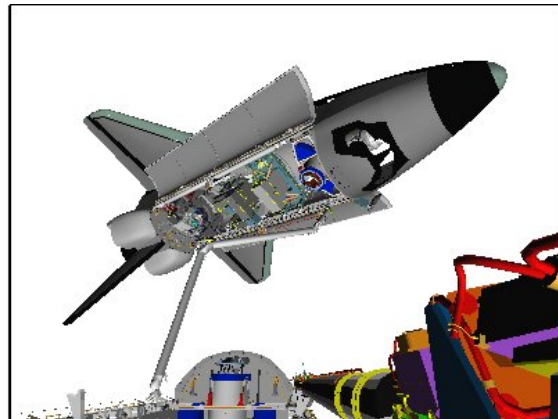

CCTV C (0,25)

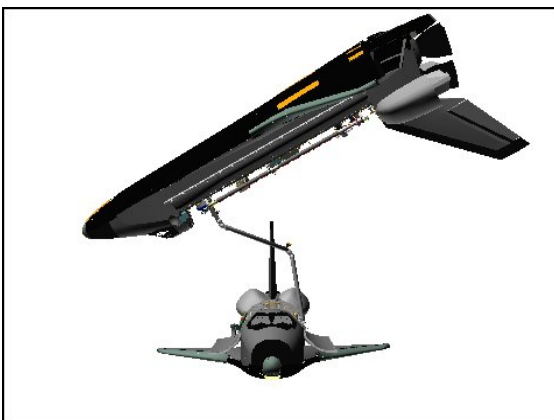

BIRD'S EYE



BIRD'S EYE

Step 5:

Drive WY- (for 11.7°)
From -1.1° to -12.8°

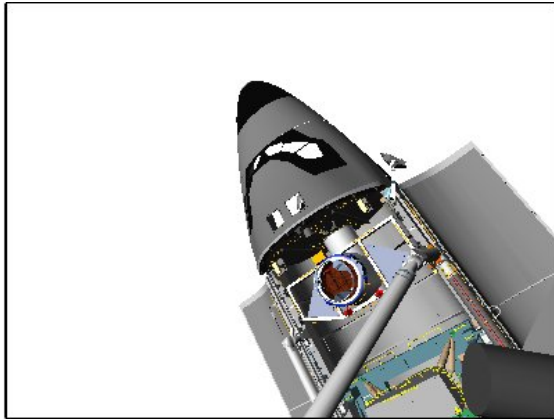

CCTV D (100,110)

Step 6:

Drive EP+ (for 27.1°)
From -57.0° to -29.9°

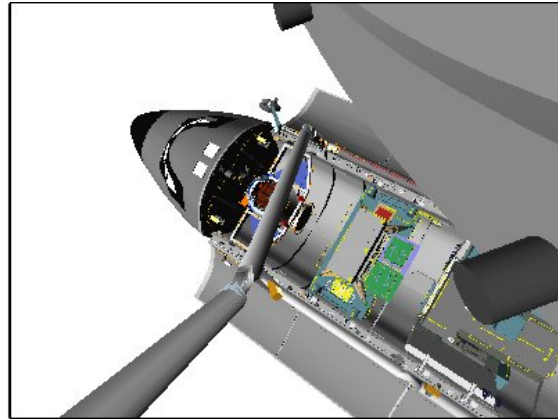

CCTV A (70,100)

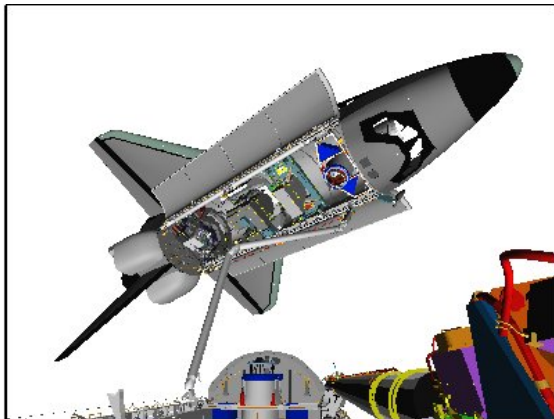

CCTV C (-5,25)

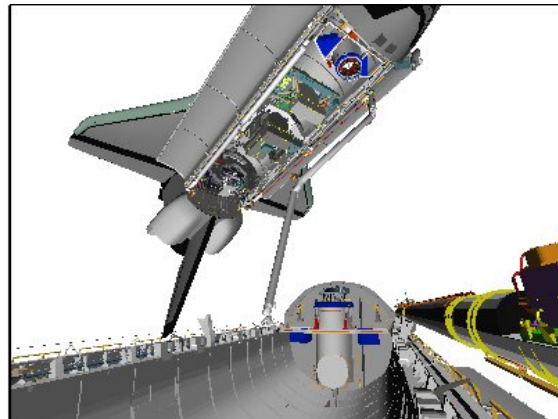

CCTV C (-15,15)



BIRD'S EYE



BIRD'S EYE

Step 7:

Drive SY+ (for 54.6°)

From -118.4° to -63.8°

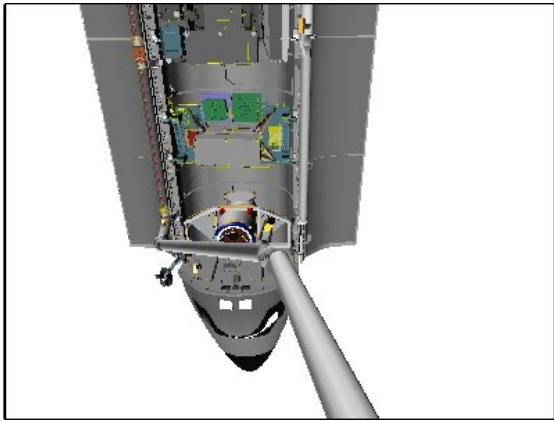

CCTV A (0,65)

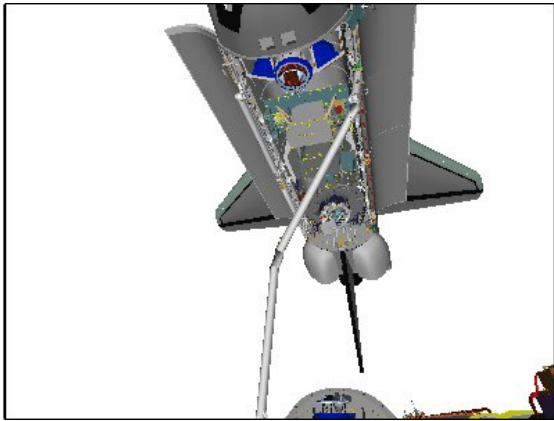

CCTV C (-15,30)

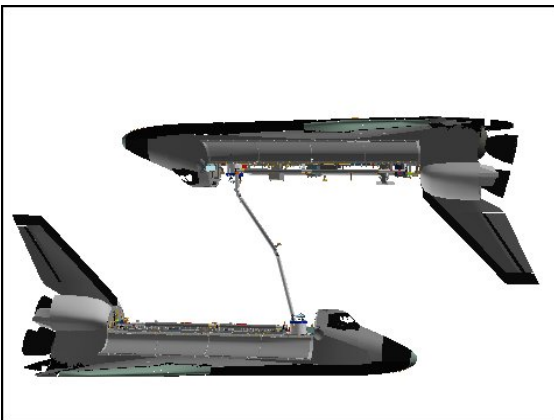

BIRD'S EYE

SJ MNVR TO PRE-CRADLE

I

1. MNVR TO PRE-CRADLE

NOTE

STS-125 manual release has been completed as part of the STS-125 Release procedure in the RNDZ book. After SEP burns complete, mnvr SRMS to pre-cradle

DNLK MON 1	A (B)
DTV MON 2	C (D)

Mnvr to PRE-CRADLE posn:

	SY	SP	EP	WP	WY	WR	
Attitude	-63.8	+58.6	-29.9	+33.9	-12.8	-47.4	
Hold/EVA				+5.0			
1: WP -					0.0		
2: WY +						0.0	
3: WR +							0.0
4: SY +	0.0						
5: EP +			-25.0				
6: SP -		+25.0					
Pre-Cradle	0.0	+25.0	-25.0	+5.0	0.0	0.0	
	X	Y	Z	PITCH	YAW	ROLL	PL ID
	-1261	-146	-551	5	2	0	0

If SINGLE MODE:
BRAKES – ON (tb-ON)
MODE – not DIRECT

PARAM – PORT TEMP
JOINT – CRIT TEMP

Step 1:

Drive WP- (for 28.9°)
From +33.9° to +5.0°



CCTV A (0,45)

Step 2:

Drive WY+ (for 12.8°)
From -12.8° to 0.0°

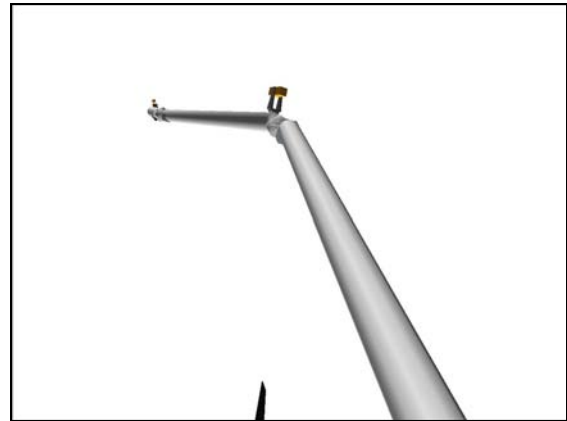

CCTV A (0,45)



CCTV C (-15,25)

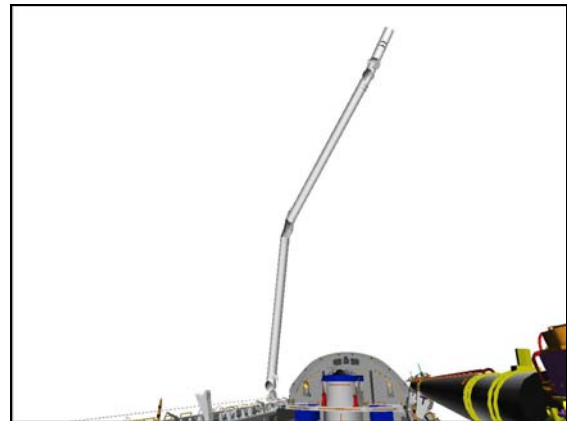

CCTV C (-15,25)

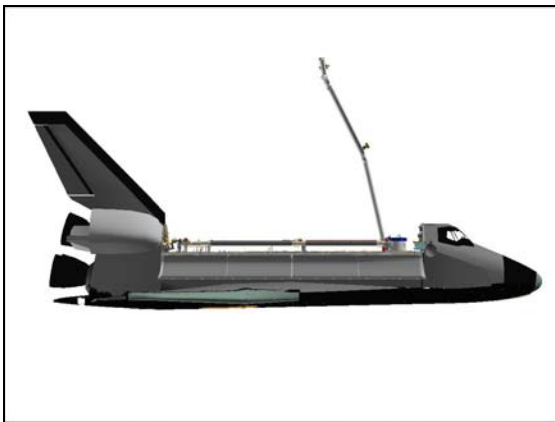

BIRD'S EYE

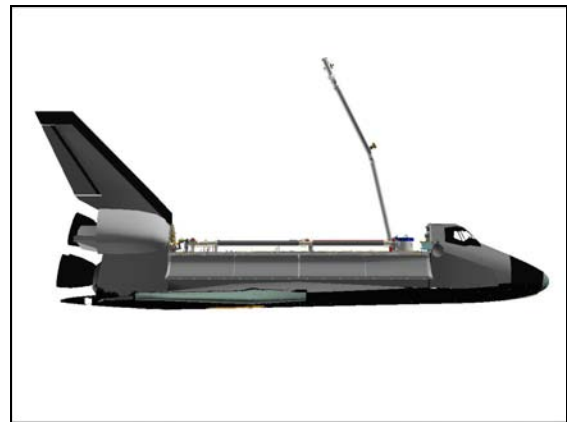

BIRD'S EYE

Step 3:

Drive WR+ (for 47.4°)

From -47.4° to 0.0°

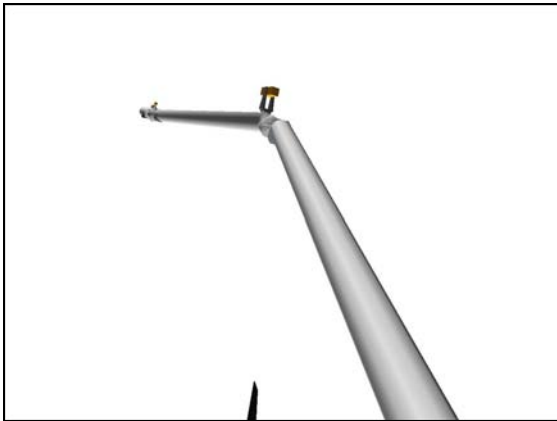

CCTV A (0,45)

Step 4:

Drive SY+ (for 63.8°)

From -63.8° to +0.0°

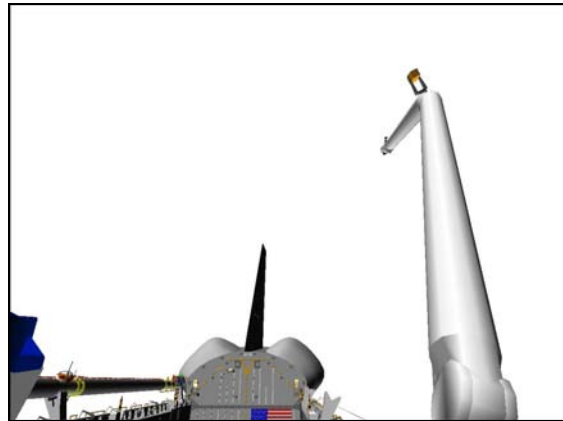

CCTV A (0,25)

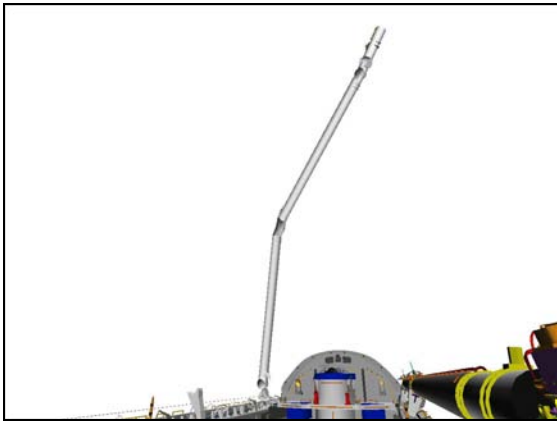

CCTV C (-15,25)



CCTV C (-45,25)

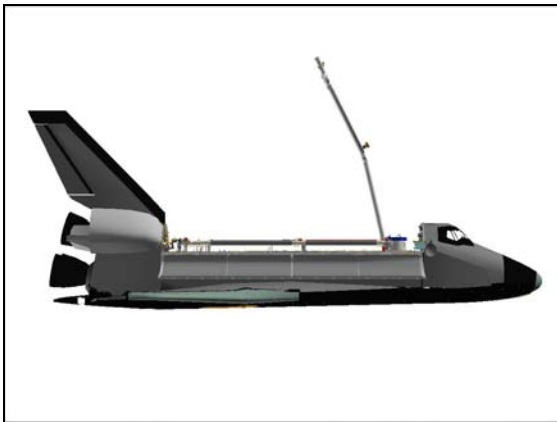

BIRD'S EYE

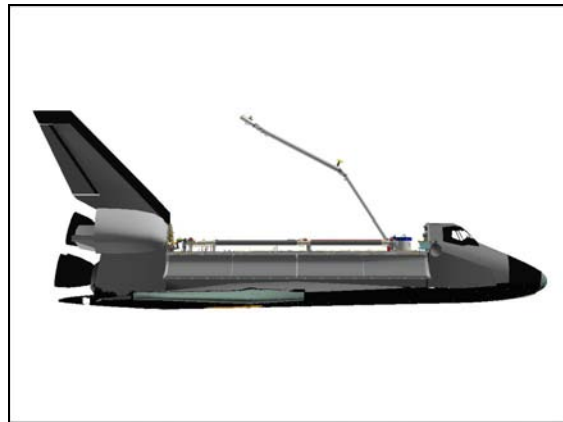

BIRD'S EYE

Step 5:

Drive EP+ (for 4.9°)
From -29.9° to -25.0°

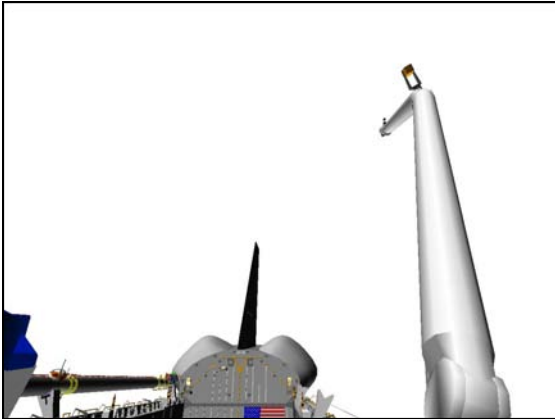

CCTV A (0,25)

Step 6:

Drive SP- (for 33.6°)
From +58.6° to +25.0°

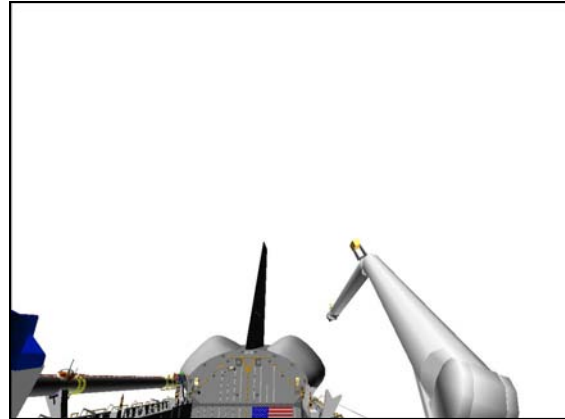

CCTV A (0,25)



CCTV C (-45,25)

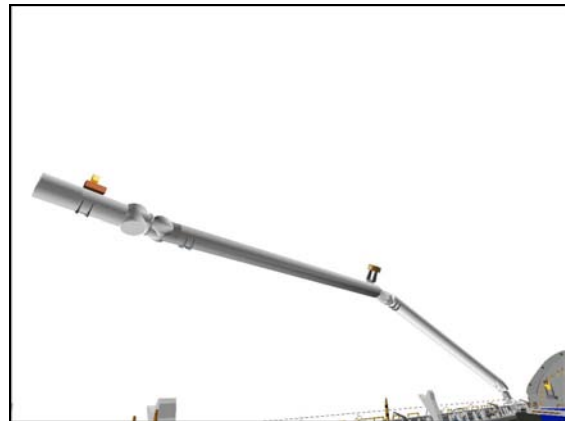

CCTV C (-45,25)

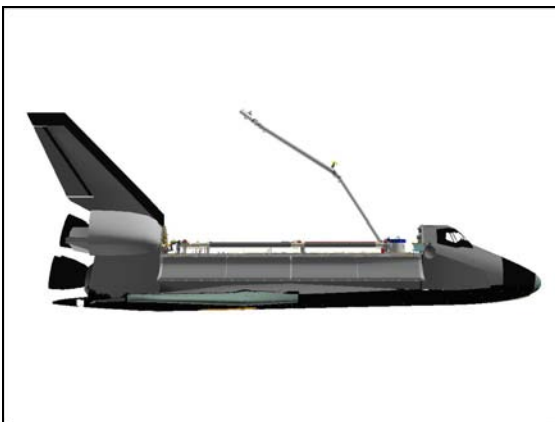

BIRD'S EYE

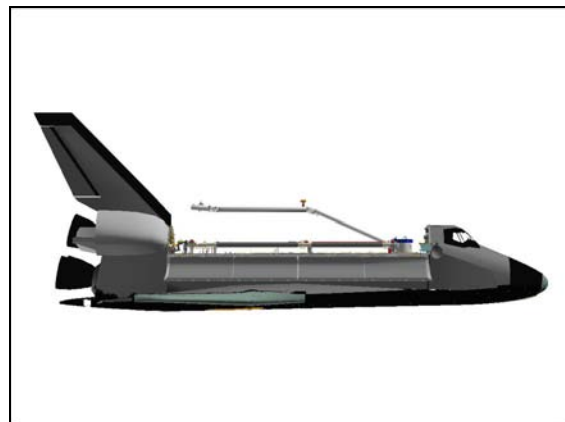

BIRD'S EYE

STS-400 REFERENCE DATA

STS-125 PL ID/POR DEFINITION – PL ID 3..... FS 4-2
ORBITER SURVEYS PL ID/POR DEFINITION – PL ID 5A FS 4-3
5B (UPLINK)..... FS 4-4
JOINT ANGLES VS POR COORDINATES FS 4-5
STS-125 OPERATIONS FS 4-5
ORBITER SURVEYS FS 4-6
OBSS BELLY TILE SURVEY AUTOSEQUENCES..... FS 4-7
CREW CABIN EE SURVEY AUTOSEQUENCES..... FS 4-12

STS-400
REF DATA

STS-125 PL ID/POR DEFINITION – PL ID 3

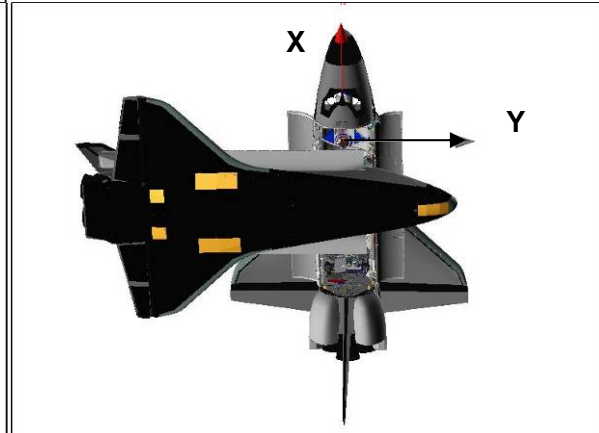
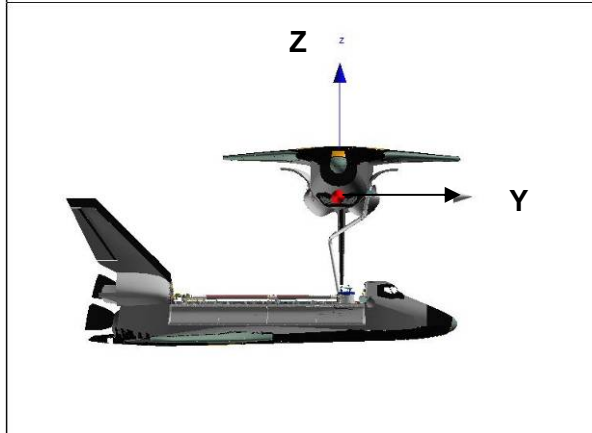
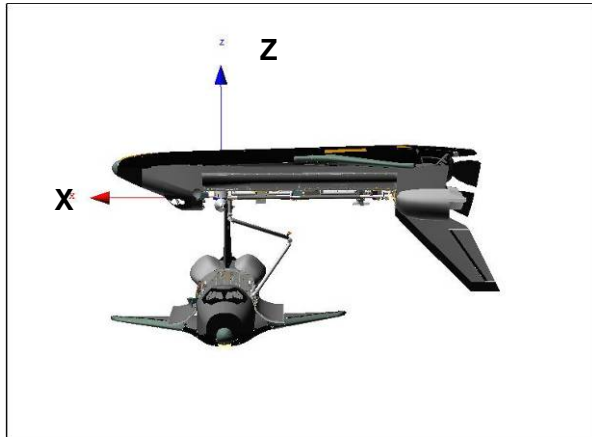

GF: OBSS EFGF

POR: Top of STS-125 external airlock

PURPOSE: Grapple and hold of STS-125

RATES: COARSE VERN

TRANS LIM ft/sec	0.14	0.042
ROT LIM deg/sec	0.14	0.042

STS-400
REF DATA

ORBITER SURVEYS PL ID/POR DEFINITION – PL ID 5A

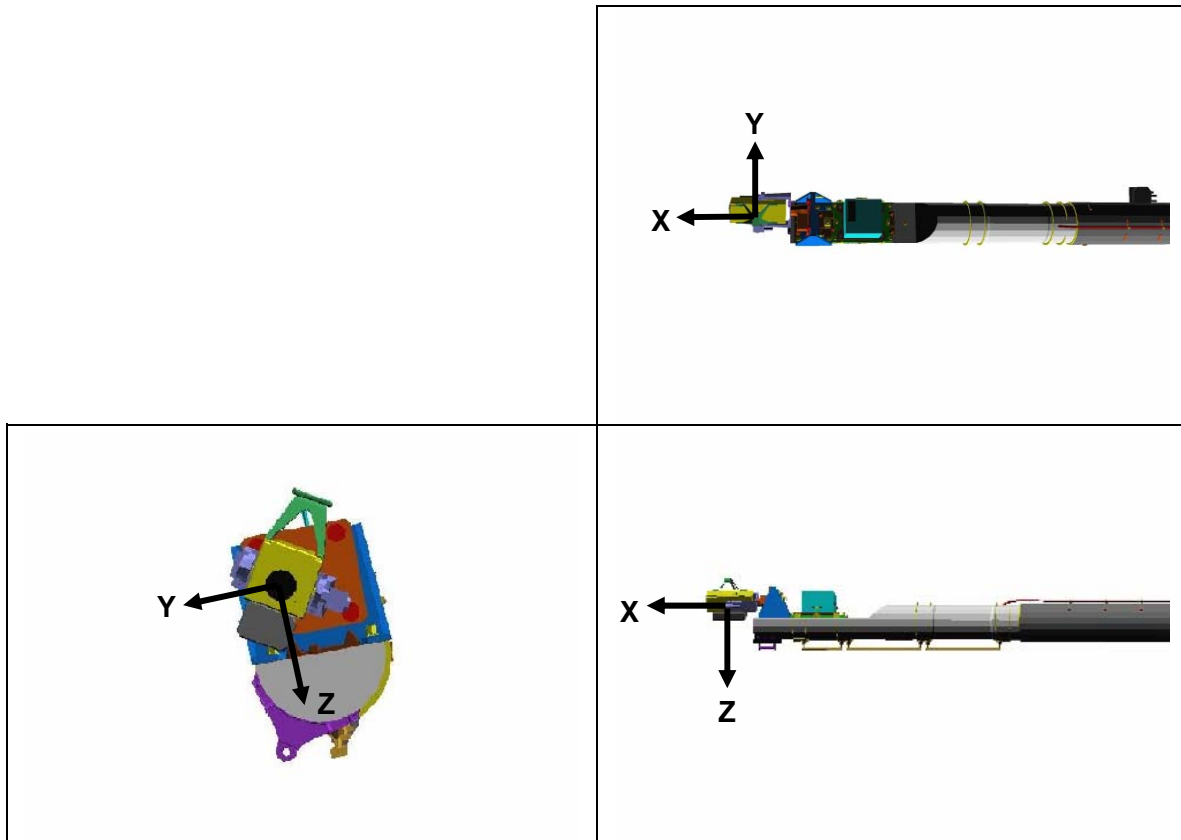

POR: POR at OBSS ITVC/LDRI PTU Pivot Point

PURPOSE: OBSS Surveys of Belly Tile using LDRI/ITVC

RATES:	<u>COARSE</u>	<u>VERN</u>
TRANS LIM ft/sec	0.23	0.14
ROT LIM deg/sec	2.64	0.88

JOINT RATES:	<u>COARSE</u>	<u>VERN</u>
SHOULDER LIM deg/sec	1.27	0.42
ELBOW LIM deg/sec	1.78	0.59
WRIST LIM deg/sec	2.64	0.88

RATIONALE: LDRI scan rate is 4.3 M/min (0.25 ft/s), while IDC scan rate is 3.6 M/min (0.20 ft/s)

ORBITER SURVEYS PL ID/POR DEFINITION – PL ID 5B (UPLINK)

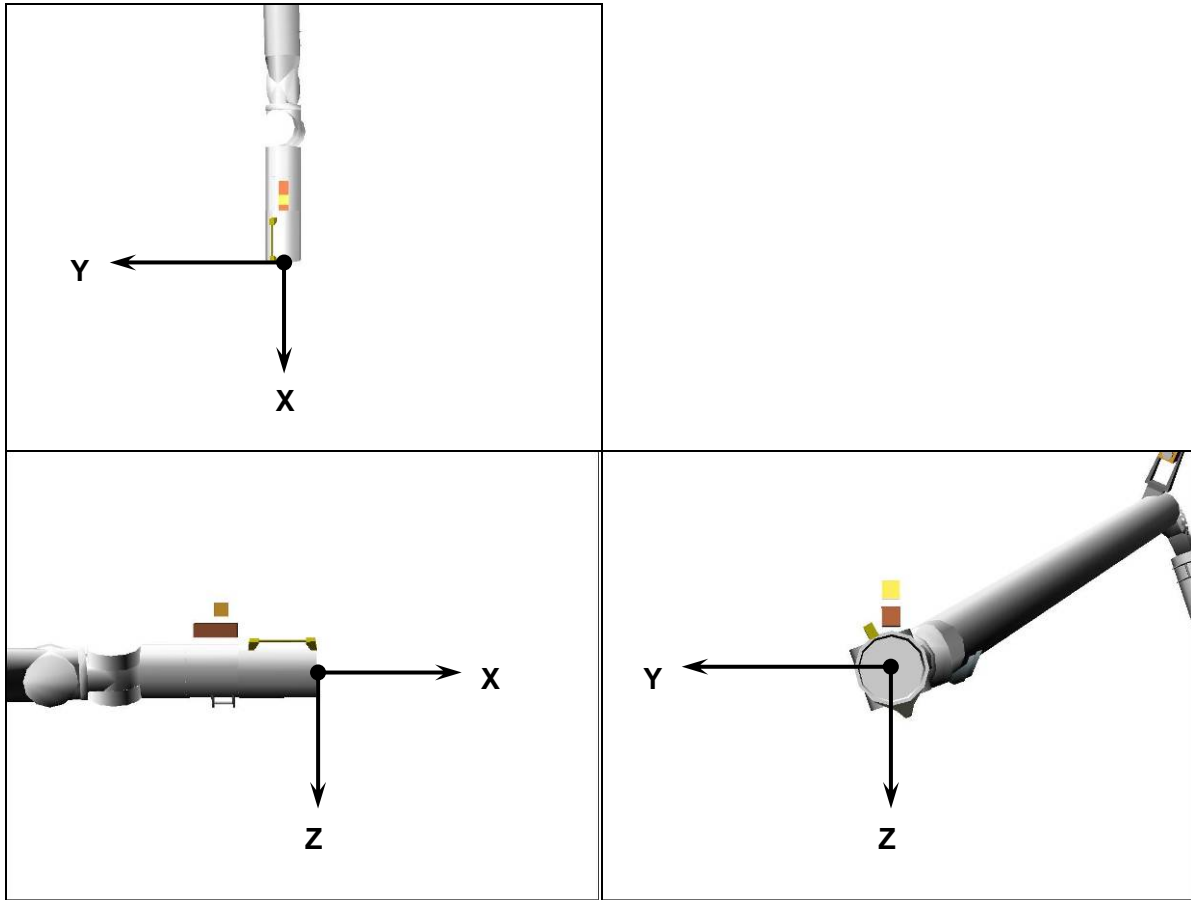

POR: Centered at tip of RMS EE

PURPOSE: Unloaded EE Crew Cabin Surveys with Reduced Translational Vernier Rates

RATES:	<u>COARSE</u>	<u>VERN</u>
TRANS LIM ft/sec	0.31	0.22
ROT LIM deg/sec	4.76	4.76

JOINT ANGLES VS POR COORDINATES

STS-125 OPERATIONS

POISED FOR CAPTURE

X	Y	Z	PITCH	YAW	ROLL	PL ID
-569	-26	-746	90	0	0	0
-598	-132	-730	360	0	191	3
SY	SP	EP	WP	WY	WR	
-124.7	+111.2	-122.7	+85.4	+11.0	-103.7	

STS-125 PRE-GRAPPLE

X	Y	Z	PITCH	YAW	ROLL	PL ID
-581	-25	-756	101	1	91	0
-687	+6	-761	11	270*	191	3
SY	SP	EP	WP	WY	WR	
-118.0	+113.7	-122.3	+77.2	-1.2	-6.0	

*display singularity

STS-125 GRAPPLE

X	Y	Z	PITCH	YAW	ROLL	PL ID
-570	-26	-815	90	349	0	0
-676	+5	-820	0	270*	180	3
SY	SP	EP	WP	WY	WR	
-118.4	+108.9	-107.4	+67.1	-1.1	-6.3	

*display singularity

ATTITUDE HOLD/EVA

X	Y	Z	PITCH	YAW	ROLL	PL ID
-850	+106	-960	90	349	0	0
-878	-1	-964	0	1	180	3
SY	SP	EP	WP	WY	WR	
-63.8	+58.6	-29.9	+33.9	-12.8	-47.4	

STS-125 UNGRAPPLE

X	Y	Z	PITCH	YAW	ROLL	PL ID
-850	+95	-901	90	349	0	0
SY	SP	EP	WP	WY	WR	
-61.7	+73.1	-62	+51.9	-13.8	-45.5	

ORBITER SURVEYS

Stbd LDRI ACAS, Point 13P

X	Y	Z	PITCH	YAW	ROLL	PL ID
-767	+322	-343	255	348	346	0
-764	+321	-325	348	346	342	1
-1328	+464	-221	348	346	12	2
-1328	+464	-221	348	346	12	5
SY	SP	EP	WP	WY	WR	
-74.9	+16.3	-74.3	-43.0	-12.2	-276.6	

Port LDRI ACAS, Point 114P

X	Y	Z	PITCH	YAW	ROLL	PL ID
-761	-657	-455	301	73	315	0
-765	-675	-455	346	348	252	1
-1323	-537	-315	346	348	282	2
-1323	-537	-315	346	348	282	5
SY	SP	EP	WP	WY	WR	
+80.9	+49.1	-50.2	+5.9	+0.6	-87.1	

Stbd Survey ACAS Start

X	Y	Z	PITCH	YAW	ROLL	PL ID
-501	+151	-586	281	25	307	0
-501	+151	-586	281	25	307	5
SY	SP	EP	WP	WY	WR	
-119.7	+58.1	-82.9	-109.8	-11.2	+82.1	

Port Survey ACAS Start

X	Y	Z	PITCH	YAW	ROLL	PL ID
-553	-230	-551	257	314	288	0
-553	-230	-551	257	314	288	5
SY	SP	EP	WP	WY	WR	
+138.2	+119.0	-123.3	-97.8	+26.7	-179.8	

OBSS BELLY TILE SURVEY AUTOSEQUENCES

STBD BELLY TILE (PL ID 5)

Auto Seq ID	Auto posn	X/ SY	Y/ SP	Z/ EP	PITCH/ WP	YAW/ WY	ROLL/ WR	Pause
7	148	-1328	+464	-221	348	346	12	P
		-74.9	+16.3	-74.3	-43.1	-12.2	-276.6	
7	149	-1291	+458	-91	334	345	10	
		-70.9	+17.1	-76.0	-48.7	-23.8	-280.7	
7	150	-1339	+223	-72	332	7	16	
		-64.6	+19.2	-77.0	-45.1	-21.6	-262.6	
7	151	-1274	+185	-63	331	12	14	
		-72.5	+18.4	-78.3	-42.1	-22.7	-250.0	
7	152	-1329	+494	-193	343	344	19	P
		-71.7	+17.0	-71.3	-42.5	-20.2	-279.0	
7	153	-1329	+247	-158	343	7	13	
		-74.3	+15.3	-75.1	-40.1	-12.8	-255.3	
7	154	-1243	+161	-97	342	16	14	
		-84.0	+6.7	-74.5	-29.2	-13.0	-236.3	
7	155	-1145	+148	-154	339	22	20	
		-94.5	+11.5	-64.0	-37.0	-12.5	-217.9	
7	156	-975	+155	-159	335	20	23	
		-114.5	+13.0	-54.4	-39.3	-12.9	-196.9	
7	157	-978	+207	-166	334	16	26	
		-114.1	+12.3	-49.1	-40.4	-12.4	-199.8	
7	158	-1152	+170	-153	343	19	13	
		-96.8	+6.4	-61.8	-40.0	-13.1	-220.8	
7	159	-1143	+224	-164	338	16	17	
		-95.9	+9.8	-54.6	-45.9	-16.6	-222.2	
7	160	-961	+230	-171	332	15	26	P
		-114.1	+9.3	-38.6	-46.4	-14.3	-199.6	
7	161	-1030	+265	-125	336	10	16	
		-110.7	+7.5	-52.0	-40.4	-19.9	-211.5	
7	162	-1145	+256	-109	340	9	12	
		-99.4	+7.6	-66.2	-35.3	-18.6	-227.1	
7	163	-1146	+184	-104	340	17	20	
		-97.4	+5.9	-66.4	-27.7	-13.0	-219.7	
7	164	-1202	+225	-104	340	14	21	
		-90.3	+4.7	-63.6	-29.6	-13.8	-229.5	
7	165	-1257	+245	-106	341	11	15	
		-83.5	+4.3	-63.4	-36.9	-15.0	-241.2	
7	166	-1185	+220	-105	341	12	13	
		-9.7	+6.9	-69.3	-32.8	-16.2	-230.2	
7	167	-1149	+268	-109	340	9	12	
		-98.6	+5.1	-61.4	-38.0	-18.5	-228.0	
7	168	-1287	+277	-104	342	3	13	
		-79.6	+11.0	-79.6	-30.3	-15.5	-253.6	
7	169	-1279	+337	-108	343	359	13	
		-81.9	+7.2	-73.3	-32.2	-15.8	-255.4	
7	170	-1018	+290	-124	335	7	12	
		-111.7	+8.3	-50.9	-44.4	-23.7	-214.0	
7	171	-1160	+385	-124	339	359	19	
		-96.9	+7.8	-61.0	-33.5	-19.9	-236.5	
7	172	-1278	+375	-120	341	357	14	
		-81.2	+9.2	-68.8	-38.0	-18.2	-257.3	

OBSS BELLY TILE SURVEY AUTOSEQUENCES (Cont)

STBD BELLY TILE (PL ID 5) (Cont)

Auto Seq ID	Auto posn	X/ SY	Y/ SP	Z/ EP	PITCH/ WP	YAW/ WY	ROLL/ WR	Pause
7	173	-1268	+429	-126	342	352	15	
		-82.4	+8.2	-68.3	-36.1	-18.8	-260.9	
7	174	-1160	+360	-116	344	357	1	
		-100.6	+3.8	-65.8	-43.2	-19.1	-242.0	
7	175	-1275	+455	-125	342	350	14	
		-81.1	+6.3	-64.8	-39.4	-18.9	-264.6	
7	176	-1328	+464	-221	348	346	12	P
		-74.9	+16.3	-74.3	-43.0	-12.2	-276.6	

PORT BELLY TILE (PL ID 5)

Auto Seq ID	Auto posn	X/ SY	Y/ SP	Z/ EP	PITCH/ WP	YAW/ WY	ROLL/ WR	Pause
1	1	-1323	-537	-315	346	348	282	P
		+80.9	+49.1	-50.2	+5.9	+0.6	-87.1	
1	2	-1364	-470	-97	357	2	3	
		+76.6	+23.9	-73.6	-25.0	+6.6	-54.9	
1	3	-1432	-117	-78	0	337	4	
		+57.7	+12.2	-72.8	-16.8	+9.7	-61.5	
1	4	-1545	-147	-80	356	338	356	
		+45.8	+9.4	-52.5	-31.6	+17.8	-49.9	
1	5	-1525	+69	-85	351	324	4	
		+31.9	+12.3	-55.7	-48.0	+19.6	-45.4	
1	6	-1437	+118	-88	355	312	2	
		+38.1	+4.7	-44.7	-43.8	+18.2	-65.9	
1	7	-1368	+53	-59	359	322	5	
		+53.0	+9.2	-73.9	-15.3	+12.6	-71.4	
1	8	-1498	+34	-71	359	332	5	
		+37.9	+6.6	-70.5	-19.4	+13.9	-46.1	
1	9	-1460	-68	-80	0	331	11	
		+52.0	+6.4	-56.2	-35.8	+10.2	-60.4	
1	10	-1390	-68	-80	0	331	11	
		+59.9	+12.6	-71.6	-25.1	+9.5	-68.5	
1	11	-1415	+55	-82	0	331	11	
		+45.4	+11.4	-88.1	-10.1	+10.7	-53.8	
1	12	-1368	+40	-58	0	333	7	
		+54.2	+7.5	-92.8	+4.2	+10.3	-61.4	
1	13	-1371	-478	-191	6	359	359	P
		+77.6	+20.7	-63.1	-26.4	-1.6	-59.2	
1	14	-1373	-11	-156	8	324	12	
		+57.6	+13.4	-69.8	-24.9	+4.5	-74.7	
1	15	-1386	+200	-176	3	306	357	
		+33.6	+17.9	-69.3	-21.8	+14.4	-70.6	
1	16	-1336	+115	-160	7	313	11	
		+49.0	+16.7	-76.1	-22.2	+8.7	-76.9	
1	17	-1336	-125	-159	4	330	7	
		+69.5	+22.7	-74.8	-25.2	+4.2	-80.2	
1	18	-1292	-119	-159	5	329	9	
		+74.8	+22.1	-75.6	-25.1	+2.7	-86.5	

OBSS BELLY TILE SURVEY AUTOSEQUENCES (Cont)

PORT BELLY TILE (PL ID 5) (Cont)

Auto Seq ID	Auto posn	X/ SY	Y/ SP	Z/ EP	PITCH/ WP	YAW/ WY	ROLL/ WR	Pause
1	19	-1304	+100	-159	8	311	16	P
		+53.3	+15.2	-70.5	-29.9	+8.7	-82.7	
1	20	-1252	+65	-106	8	315	19	
		+65.3	+6.7	-67.5	-26.0	+7.6	-90.5	
1	21	-1000	+13	-113	359	299	359	
		+85.9	+17.8	-58.1	-29.8	+1.5	-127.1	
1	22	-968	+128	-135	346	305	0	
		+95.3	+50.3	-115.9	-3.7	+12.2	-130.1	
1	23	-762	+84	-132	207	272	216	
		+76.6	+20.1	-57.0	-34.9	+13.5	-148.9	
1	24	-421	+57	-134	174	324	173	
		+52.0	+13.5	-82.4	-11.3	+9.9	-176.2	
1	25	-270	+21	-200	160	324	174	P
		+80.4	+7.5	-82.0	-4.1	+18.6	-202.6	
1	26	-380	-25	-178	169	315	196	
		+71.9	+16.4	-68.7	-14.0	+30.5	-190.6	
1	27	-385	-65	-180	174	319	201	
		+67.1	+21.9	-70.8	-14.5	+31.5	-191.0	
1	28	-256	-51	-202	165	329	201	P
		+74.5	+13.6	-87.6	+16.2	+33.9	-211.4	
1	29	-444	-134	-142	183	325	209	
		+56.7	+19.4	-55.7	-22.1	+34.2	-188.5	
1	30	-418	-15	-129	182	313	202	
		+68.3	+25.7	-76.3	-11.3	+25.4	-184.9	
1	31	-933	+75	-129	344	307	358	
		+103.0	+50.0	-106.2	-10.5	+9.5	-135.6	
1	32	-915	-13	-118	349	323	6	P
		+124.6	+39.3	-92.4	-16.8	+4.0	-139.4	
1	33	-1267	+10	-106	358	329	8	
		+72.1	+26.6	-107.0	+0.5	+9.7	-82.8	
1	34	-1227	-37	-109	357	335	18	
		+85.1	+29.8	-111.3	-6.4	+10.6	-88.1	
1	35	-882	-98	-125	341	323	350	
		+123.2	+45.6	-79.6	-25.9	-3.6	-138.3	
1	36	-882	+35	-128	344	311	352	
		+115.9	+47.1	-96.8	-13.8	-1.5	-143.6	
1	37	-496	-74	-142	211	304	213	
		+77.6	+47.0	-67.3	-32.7	+4.9	-178.8	
1	38	-500	-165	-154	213	313	216	
		+71.0	+45.1	-50.7	-41.6	+8.4	-181.2	
1	39	-566	-152	-144	200	314	208	
		+59.4	+11.7	-8.5	-59.2	+19.3	-175.8	
1	40	-544	-78	-133	201	306	210	P
		+66.9	+31.6	-51.9	-36.6	+17.2	-174.1	
1	41	-526	-122	-130	203	311	212	
		+65.6	+32.3	-48.1	-37.8	+17.3	-177.8	
1	42	-572	-149	-139	213	313	222	
		+62.0	+38.4	-44.0	-41.5	+20.3	-174.8	

OBSS BELLY TILE SURVEY AUTOSEQUENCES (Cont)

PORT BELLY TILE (PL ID 5) (Cont)

Auto Seq ID	Auto posn	X/ SY	Y/ SP	Z/ EP	PITCH/ WP	YAW/ WY	ROLL/ WR	Pause
1	43	-550	+6	-113	192	302	202	
		+66.7	+26.3	-63.1	-26.8	+18.1	-170.6	
1	44	-874	+33	-104	302	283	314	
		+73.5	+29.8	-57.3	-37.8	+20.1	-137.6	
1	45	-890	-23	-109	308	289	319	
		+77.8	+32.9	-51.4	-42.3	+18.3	-137.2	
1	46	-604	-60	-119	223	296	231	
		+75.9	+37.7	-53.2	-36.8	+13.5	-167.6	
1	47	-610	-156	-134	235	307	243	
		+73.3	+45.5	-41.0	-44.3	+15.2	-169.6	
1	48	-670	-195	-150	246	311	255	
		+70.8	+43.7	-22.8	-54.2	+19.7	-165.1	
1	49	-653	-92	-124	237	299	247	
		+73.5	+43.2	-49.1	-40.5	+18.0	-163.5	
1	50	-947	-48	-105	348	310	353	
		+102.8	+31.5	-70.8	-25.9	+1.3	-132.4	
1	51	-995	-100	-107	349	315	355	
		+101.1	+29.9	-65.5	-30.5	+3.0	-125.8	
1	52	-645	-163	-132	297	307	307	
		+112.0	+34.1	-16.0	-57.5	-2.6	-157.8	
1	53	-1000	-170	-113	337	313	348	
		+94.3	+31.3	-44.7	-47.8	+12.0	-123.5	
1	54	-987	-70	-104	338	302	349	
		+86.6	+29.2	-52.7	-41.8	+14.0	-126.6	
1	55	-1313	-71	-102	349	323	4	
		+63.5	+34.3	-80.3	-35.5	+19.2	-79.4	
1	56	-1265	-155	-103	344	331	354	
		+74.1	+49.8	-95.9	-23.3	+19.2	-85.1	
1	57	-1389	-149	-102	355	345	0	
		+60.7	+32.0	-107.1	-0.2	+13.8	-56.7	
1	58	-1375	-202	-106	355	348	1	
		+66.1	+34.1	-106.1	-3.0	+12.2	-58.7	
1	59	-1220	-167	-147	354	321	0	P
		+79.2	+27.3	-56.2	-42.9	+9.5	-98.7	
1	60	-1170	-160	-160	351	320	0	
		+83.5	+35.4	-63.8	-43.3	+11.1	-103.8	
1	61	-1198	-130	-165	6	336	4	
		+93.9	+24.9	-93.2	-6.2	-5.4	-98.1	
1	62	-1016	-136	-165	3	336	359	
		+121.7	+24.8	-81.5	-17.5	-13.5	-124.4	
1	63	-1020	-184	-171	3	341	359	
		+123.6	+24.8	-79.8	-19.6	-14.0	-121.3	
1	64	-1195	-152	-161	7	342	8	
		+98.5	+20.9	-95.1	-4.7	-6.2	-97.1	
1	65	-1181	-200	-165	7	345	6	
		+102.0	+21.4	-91.5	-7.6	-8.1	-97.4	
1	66	-1006	-209	-181	2	342	347	P
		+126.2	+27.0	-79.1	-14.7	-23.2	-120.2	
1	67	-1018	-285	-137	355	359	345	
		+137.1	+34.4	-101.0	+4.9	-21.1	-112.6	

OBSS BELLY TILE SURVEY AUTOSEQUENCES (Cont)

PORT BELLY TILE (PL ID 5) (Cont)

Auto Seq ID	Auto posn	X/ SY	Y/ SP	Z/ EP	PITCH/ WP	YAW/ WY	ROLL/ WR	Pause
1	68	-1339	-253	-116	357	352	0	
		+75.1	+33.0	-106.7	+1.8	+7.8	-63.8	
1	69	-1310	-316	-125	357	352	0	
		+82.0	+34.7	-96.4	-9.4	+5.6	-70.4	
1	70	-1045	-325	-135	357	0	345	
		+130.1	+31.2	-97.4	+5.7	-19.0	-104.9	
1	71	-1160	-344	-125	357	6	0	
		+113.3	+33.2	-115.7	+11.7	-4.8	-85.9	
1	72	-1333	-354	-140	357	352	0	
		+79.3	+35.4	-88.1	-18.6	+6.5	-67.8	
1	73	-1319	-415	-140	357	352	0	
		+82.5	+29.8	-70.5	-30.4	+5.5	-70.9	
1	74	-1170	-360	-128	1	11	8	
		+112.0	+22.7	-112.2	+9.4	-6.7	-80.9	
1	75	-1327	-475	-137	0	0	355	
		+82.4	+25.8	-73.6	-17.9	+3.1	-63.1	
1	76	-1315	-455	-137	0	0	355	
		+83.7	+27.7	-80.1	-13.3	+2.6	-64.3	
1	77	-1323	-537	-315	346	348	282	P
		+80.9	+49.1	-50.2	+5.9	+0.6	-87.1	

CREW CABIN EE SURVEY AUTOSEQUENCES

STBD CREW CABIN (PL ID 5)

Auto Seq ID	Auto posn	X/ SY	Y/ SP	Z/ EP	PITCH/ WP	YAW/ WY	ROLL/ WR	Pause
2	78	-501	+151	-586	281	25	307	P
		-119.7	+58.1	-82.9	-109.8	-11.2	+82.1	
2	79	-249	+91	-502	270	24	305	
		-150.3	+24.7	-37.4	-102.5	-36.7	+106.3	
2	80	-247	+30	-517	271	7	305	
		-157.5	+38.1	-51.8	-88.0	-23.9	+119.4	
2	81	-493	+109	-638	281	17	306	
		-123.1	+67.8	-82.0	-112.9	-9.7	+85.1	
2	82	-533	+38	-645	281	4	317	
		-124.8	+89.3	-99.7	-105.2	-3.9	+98.9	
2	83	-246	+16	-519	270	7	305	
		-159.0	+40.0	-53.8	-86.4	-24.6	+121.2	
2	84	-417	-9	-612	288	1	315	
		-149.0	+77.3	-89.5	-103.9	-7.3	+118.9	
2	85	-536	-4	-638	281	359	318	P
		-130.6	+98.8	-106.8	-103.2	-3.3	+105.5	

MNVR TO PORT CREW CABIN (PL ID 0)

Auto Seq ID	Auto posn	X/ SY	Y/ SP	Z/ EP	PITCH/ WP	YAW/ WY	ROLL/ WR	Pause
7	148	-536	-4	-638	281	359	318	P
		-130.6	+98.8	-106.8	-103.2	-3.3	+105.5	
7	149	-761	+32	-651	259	359	17	
		-67.1	+98.9	-106.8	-103.3	-3.1	+105.0	
7	150	-1042	-345	-580	323	24	333	
		+24.5	+77.8	-80.9	-20.0	+12.3	-37.7	
7	151	-553	-230	-551	257	314	288	P
		+138.3	+118.9	-123.3	-97.5	+26.2	-180.8	

PORT CREW CABIN (PL ID 5)

Auto Seq ID	Auto posn	X/ SY	Y/ SP	Z/ EP	PITCH/ WP	YAW/ WY	ROLL/ WR	Pause
3	86	-553	-230	-551	257	314	288	P
		+138.3	+118.9	-123.3	-97.5	+26.2	-180.8	
3	87	-279	-148	-473	259	313	271	
		+172.1	+58.2	-81.2	-62.7	+28.7	-236.5	
3	88	-514	-212	-591	268	313	291	
		+155.4	+113.3	-113.1	-101.1	+25.5	-201.3	
3	89	-582	-153	-610	268	313	277	
		+172.2	+135.3	-124.6	-103.2	+27.5	-233.9	
3	90	-524	-157	-610	268	313	277	
		+173.7	+120.3	-117.4	-94.6	+27.5	-235.7	
3	91	-276	-146	-473	259	313	292	P
		+172.5	+57.5	-80.4	-62.7	+28.6	-215.9	

CREW CABIN EE SURVEY AUTOSEQUENCES (Cont)

MNVR TO PRE-CRADLE (PL ID 0)

Auto Seq ID	Auto posn	X/ SY	Y/ SP	Z/ EP	PITCH/ WP	YAW/ WY	ROLL/ WR	Pause
8	152	-276	-146	-473	259	313	292	P
		+172.5	+57.5	-80.4	-62.7	+28.6	-215.9	
8	153	-881	-572	-547	263	32	9	
		+60.0	+57.8	-40.3	-62.1	+28.6	-44.6	
8	154	-1261	-146	-551	5	2	0	P
		0	+25.0	-25.0	+5	0	0	

This Page Intentionally Blank

CUE CARD CONFIGURATION

CUE CARD
CONFIG

This Page Intentionally Blank

TOP

HOOK
VELCRO

OBSS ITVC SCAN PATTERN CUE CARD – STBD BELLY TILE SURVEY

ITVC

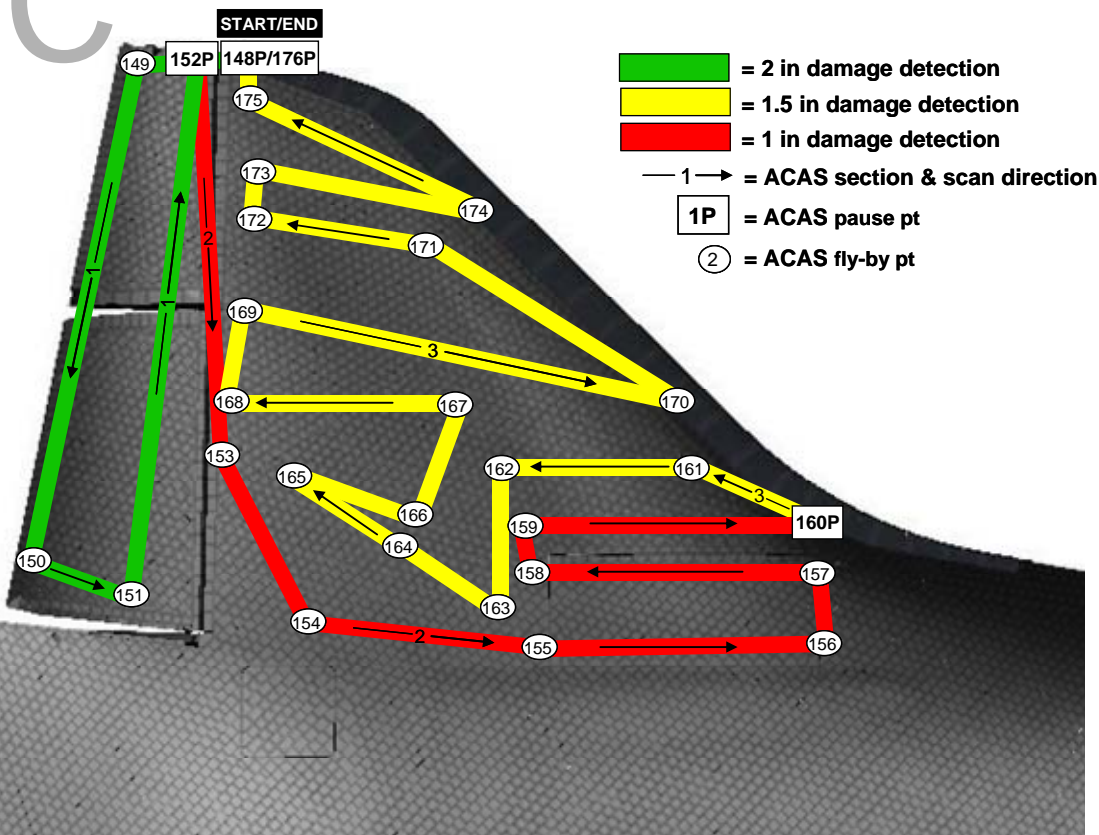

(reduced copy)

FS CC 5-3

PDRS/400/FIN A

PDRS-9a/400/O/A

TOP
 Back of 'OBSS ITVC SCAN PATTERN CUE CARD – STBD BELLY TILE SURVEY'

HOOK
 VELCRO

OBSS ITVC SCAN PATTERN CUE CARD – PORT BELLY TILE SURVEY

ITVC

 = 1.5 in damage detection
 = 1 in damage detection

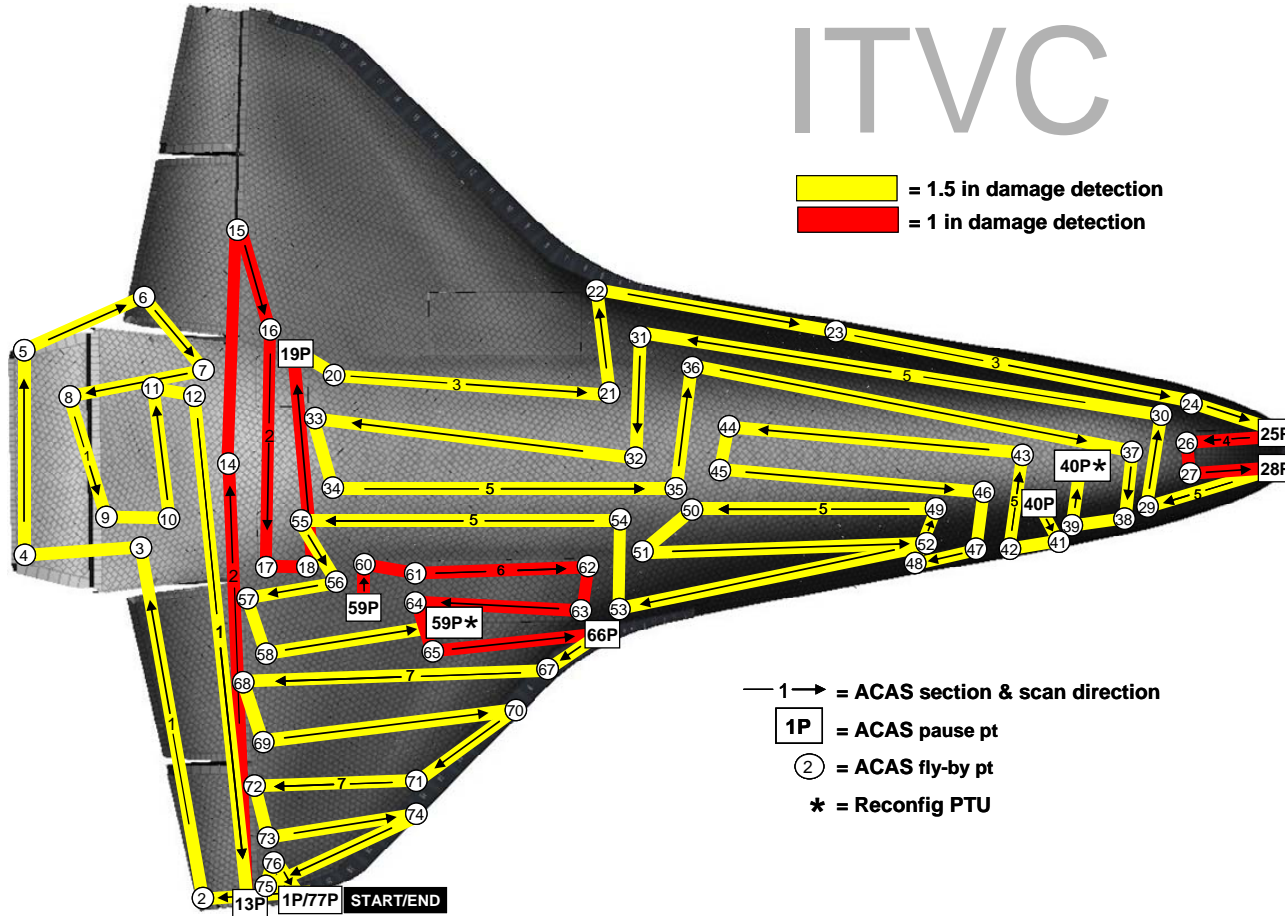

— 1 → = ACAS section & scan direction
 1P = ACAS pause pt
 ② = ACAS fly-by pt
 * = Reconfig PTU

PDRS-9b/400/O/A

(reduced copy)

FS CC 5-4

PDRS/400/FIN A

TOP

HOOK
VELCRO

RMS SURVEY TIMELINE CUE CARD

<u>PROCEDURE</u>	<u>STEPS</u>
OBSS UNBERTH (PDRS GEN 7-3)	ALL
OBSS LDRI/IDC RCC SURVEY – STBD (PDRS GEN 7-9)	1 - 2*
<p>* SURVEY STBD OMS: After mnvr in step 2, MNVR TO FLAT FIELD POSN, select LDRI Mode 2 (ITVC video) and adjust LDRI pan/tilt/zoom/focus to +178.6, -249, 18.3 HFOV, and 20 ft respectively, to view OMS pod Check with MCC to verify correct view View will need to be recorded for at least 10 sec Pan/tilt back to +103, -260 respectively, set focus to 12 ft, and select LDRI Mode 6 to set up for step 3</p>	
OBSS LDRI/IDC RCC SURVEY – STBD (PDRS GEN 7-11)	3-4
OBSS ITVC BELLY TILE SURVEY – STBD (PDRS FS 2-2)	ALL
OBSS LDRI/IDC RCC SURVEY – STBD (PDRS GEN 7-15)	5 - END
OBSS LDRI/IDC RCC SURVEY – NOSE CAP (PDRS GEN 7-27)	ALL
OBSS LDRI/IDC RCC SURVEY – PORT (PDRS GEN 7-35)	1 - 5
OBSS ITVC BELLY TILE SURVEY – PORT (PDRS FS 2-9)	ALL
OBSS LDRI/IDC RCC SURVEY – PORT (PDRS GEN 7-42)	6 - 10**
<p>**SURVEY PORT OMS: After step 10, PORT LDRI ACAS, SECTIONS 6 AND 7, adjust LDRI pan/tilt/zoom/focus to 3, -142, 10 HFOV, and 40 ft respectively, to place black tiles in center of FOV Check with MCC to verify correct view Prior to mnvr to OBSS HOVER, turn recorders ON for 10 sec and zoom out until OMS pod fills up the FOV Leave recorders on for remainder of mnvr while panning/tilting/zooming (wait 5-10 sec between PTU adjustments to avoid blurring image) to center ITVC on black tiles When black tiles out of view, pan/tilt to follow vertical stabilizer Turn recorders off at end of mnvr</p>	
OBSS LDRI/IDC RCC SURVEY – PORT (PDRS GEN 7-50)	11
OBSS BERTH (PDRS GEN 7-52)	ALL

PDRS-10a/400/O/B

(reduced copy)

TOP
Back of 'RMS SURVEY TIMELINE CUE CARD'

HOOK
VELCRO

PDRS-10b/400/O/A

(reduced copy)

FS CC 5-6

PDRS/400/FIN A

Fabricate as transparency

ZOOM 34.0 HFOV
FOCUS 5.0 FT
EYEPOINT APPROX 18 IN

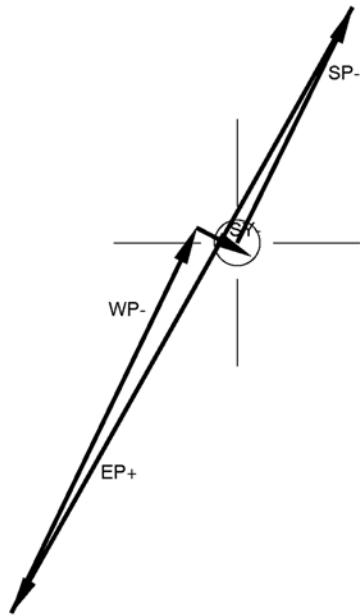

STS-125 ORBITER SJ GRAPPLE WRIST CCTV

PDRS-11a/400/O/A

(reduced copy)

FS CC 5-7

PDRS/400/FIN A

TOP

HOOK
VELCRO

STS-400 END EFFECTOR CUE CARD

MA – RELEASE or PL/EE Interface Suspect
 Stop maneuver
 DAP: FREE
 If PL/EE interface is suspect and RMS/PL config is unsafe:
 PULL TEST (PL follows RMS or pin clear of EE)
 If expedited release required:
 MAN OPEN ($\sqrt{\text{OPEN}}$ tb-gray, 3 sec max)
 If no joy, B/U RELEASE (10 sec)
 Maneuver arm to safe distance

MA – DERIGIDIZE

Stop maneuver
 DAP: FREE
 If OBSS grappled:
 SPEE PWR – OFF

R12

MAN RIGIDIZE ($\sqrt{\text{RIGID}}$ tb-gray, 25 sec max)

RMS – GENERIC RELEASE

NO AUTO RELEASE (2 or 3 snare tbs wrong: OPEN, CLOSE, CAPTURE)

MAN OPEN ($\sqrt{\text{OPEN}}$ tb-gray, 3 sec max) >>
 B/U RELEASE (10 sec)

MANUAL RELEASE (Auto release available)

NO MANUAL DERIGID

MAN OPEN ($\sqrt{\text{OPEN}}$ tb-gray, 3 sec max) >>
 B/U RELEASE (10 sec)

NO MANUAL RELEASE (2 or 3 tbs wrong: OPEN, CLOSE, CAPTURE)

AUTO RELEASE ($\sqrt{\text{OPEN}}$ tb-gray, 3 sec max) >>
 B/U RELEASE (10 sec)

RMS – CAPTURE

MISSED GRAPPLE OR AUTO CAPTURE SEQUENCE ABORTED

Complete in manual:
 If CLOSE tb – bp, MAN CLOSE ($\sqrt{\text{CLOSE}}$ tb-gray, 3 sec max)
 If CAPTURE tb – bp, PULL TEST (PL follows RMS or pin clear of EE)
 If PL snared, MAN RIGIDIZE ($\sqrt{\text{RIGID}}$ tb-gray, 25 sec max)

PDRS-13a/400/O/A

(reduced copy)

TOP
Back of 'STS-400 END EFFECTOR CUE CARD'

HOOK
VELCRO

STS-400 JOINT SLIP RECOVERY CUE CARD

MA – C/W CHECK CRT LT – PDRS SLIP SY (SP, EP, WP, WY, WR, ALL)

If any RMS POR outside the range listed below, continue with cue card recovery:

X	Y	Z	
-903 to -853	-13 to +15	-1030 to -899	Actual
+/- 25 in	+/- 14 in	+/- 65 in	REL

If EVA in progress:

Notify IV: Complete current RMS/Rope translation, if possible, slacken rope and standby for RMS cleanup

A6U Verify DAP: FREE

SM 94 PDRS CONTROL

END POS – ITEM 18 ~~-8 7 8~~ -1 ~~-9 6 4~~ EXEC
 ATT – ITEM 21 +0 +1 +1 ~~8 0~~ EXEC
 CMD CK – ITEM 25 EXEC (GOOD)

RHC RATE – VERN (RATE MIN tb-ON)

BRAKES – OFF (tb-OFF)
 MODE – OPR CMD, ENTER (READY lt on)
 AUTO SEQ – PROCEED (IN PROG lt on)

When AUTO SEQ IN PROG lt – off:

BRAKES – ON (tb-ON)
 PARAM – PORT TEMP
 JOINT – CRIT TEMP

A6U DAP: as reqd

If EVA in progress:

Notify IV: RMS cleanup complete. Go to re-tension rope and resume EVA activities

PDRS-13b/400/O/A

This Page Intentionally Blank



PDRS OPS C/L

**STIS
400**