

# Photo/TV Checklist

## Mission Operations Directorate Operations Division

Generic, Rev I  
June 5, 2007

### NOTE

For STS-120 and subsequent flights

National Aeronautics and  
Space Administration

Lyndon B. Johnson Space Center  
Houston, Texas



Verify this is the correct version for the pending operation (training, simulation or flight).  
Electronic copies of FDF books are available. URL: <http://mod.jsc.nasa.gov/do3/FDF/index.html>



PHOTO/TV C/L

GENERIC, REV I (June 5, 2007)

## PCN-7 (Sept 30, 2009) Sheet 1 of 1

List of Implemented Change Requests (482s):

P/TV-00741

P/TV-00742

Incorporate the following:

1. Replace iii thru viii
2. Replace 4-1 and 4-2
3. Replace 5-1 and 5-2
4. Replace 7-1 and 7-2, 7-15 thru 7-18 (4 pages),  
After 7-18, add 7-18a and 7-18b (2 pages)  
Replace 7-23 and 7-24
5. Replace 8-1 and 8-2
6. Replace section 9 (4 pages)
7. Replace 12-15 thru 12-18 (4 pages)
8. Replace 13-3 and 13-4
9. Replace section 16 (16-1 thru 16-6)
10. Replace section 20 (20-1 thru 20-22)
11. Replace section 21 (21-1 and 21-2)

**NOTE**

For STS-129 and subsequent flights

Prepared by:

  
 Mission Lead

  
 Publication Manager

Approved by:

  
 Lead, Shuttle Photo/TV Group

  
 Manager, Flight Procedures

Accepted by:

  
 FDF Manager

Encl: 62 pages

**File this PCN immediately behind the front cover as a permanent record**



PHOTO/TV C/L

GENERIC, REV I (June 5, 2007)

## PCN-6 (May 20, 2009) Sheet 1 of 1

List of Implemented Change Requests (482s):

P/TV-00740

Incorporate the following:

1. Replace iii thru viii
2. Replace section 4 (4-1 thru 4-32)
3. Delete section 4A
4. Replace section 5 (5-1 thru 5-24)
5. Delete section 5A
6. Replace section 7 (7-1 thru 7-24)
7. Delete section 7A
8. Replace section 9 (9-1 thru 9-6)
9. After 12-12, add 12-12a and 12-12b

**NOTE**

For STS-127 and subsequent flights

Prepared by:

  
Mission Lead  
Publication Manager

Approved by:

  
Lead, Shuttle Photo/TV Group  
Manager, Flight Procedures

Accepted by:

  
FDF Manager

Encl: 94 pages

**File this PCN immediately behind the front cover as a permanent record**



PHOTO/TV C/L	GENERIC, REV I (June 5, 2007)
--------------	-------------------------------

PCN-5 (Oct 17, 2008) Sheet 1 of 1

List of Implemented Change Requests (482s):

P/TV-0722

P/TV-0723

<p><b>NOTE</b> For STS-126 and subsequent flights</p>
---

Incorporate the following:

1. Replace iii thru viii
2. After 5-38, add section 5A (5A-1 thru 5A-24)
3. After 7-16, add section 7A (7A-1 thru 7A-24)

Prepared by:   
Mission Lead

  
Publication Manager

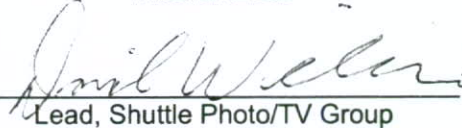
Approved by:   
Lead, Shuttle Photo/TV Group

  
Manager, Shuttle Procedures Management

Accepted by:   
FDF Manager

Encl: 54 pages

<b>File this PCN immediately behind the front cover as a permanent record</b>
---





PHOTO/TV C/L	GENERIC, REV I (June 5, 2007)
--------------	-------------------------------

PCN-4 (Aug 22, 2008) Sheet 1 of 1

List of Implemented Change Requests (482s):

P/TV-0718

P/TV-0719

Incorporate the following:

1. Replace iii thru viii
2. After 4-30, add section 4A (4A-1 thru 4A-32)

<b>NOTE</b> For STS-125 and subsequent flights
---

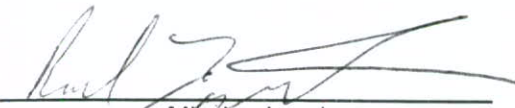
Prepared by:   
Mission Lead

  
Publication Manager

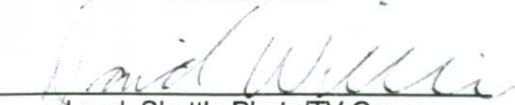
Approved by:   
Lead, Shuttle Photo/TV Group

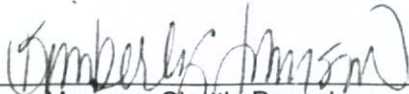
  
Manager, Shuttle Procedures Management

Accepted by:   
FDF Manager

Encl: 38 pages

<b>File this PCN immediately behind the front cover as a permanent record</b>
---



PHOTO/TV C/L	GENERIC, REV I (June 5, 2007)
--------------	-------------------------------

PCN-3 (April 4, 2008) Sheet 1 of 1

List of Implemented Change Requests (482s):

P/TV-0717

Incorporate the following:

1. Replace iii thru vi
2. Replace 11-9 and 11-10

<p><b>NOTE</b> For STS-124 and subsequent flights</p>
---

Prepared by:   
Mission Lead

  
Publication Manager

Approved by:   
Lead, Shuttle Photo/TV Group

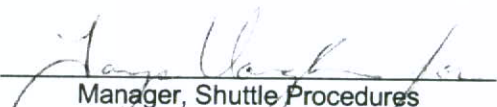
  
Manager, Shuttle Procedures Management

Accepted by:   
FDF Manager

Encl: 6 pages

<b>File this PCN immediately behind the front cover as a permanent record</b>
---



PHOTO/TV C/L	GENERIC, REV I (June 5, 2007)
--------------	-------------------------------

PCN-2 (Nov 7, 2007) Sheet 1 of 1

List of Implemented Change Requests (482s):

P/TV-0716

Incorporate the following:

1. Replace iii thru vi
2. Replace 7-9 and 7-10
3. Replace 11-1 and 11-2, 11-5 thru 11-10
4. Replace 20-1 and 20-2, 20-7 and 20-8, 20-15 and 20-16

<p><b>NOTE</b> For STS-122 and subsequent flights</p>
---

Prepared by: *David Walker FOR PAUL TWERINA* Mission Lead      *Carol H. Pierce* Publication Manager

Approved by: *David Walker* Lead, Shuttle Photo/TV Group      *(Signature)* Manager, Shuttle Procedures Management

Accepted by: *Michael T. ...* FDF Manager

Encl: 20 pages

<b>File this PCN immediately behind the front cover as a permanent record</b>
---



PHOTO/TV C/L

GENERIC, REV I (June 5, 2007)

## PCN-1 (Sept 14, 2007) Sheet 1 of 1

List of Implemented Change Requests (482s):

P/TV-0714  
P/TV-0715

Incorporate the following:

1. Replace iii thru vi
2. Replace 4-11 and 4-12, 4-19 thru 4-24
3. Replace Section 5 (38 pages)  
After 5-38, delete 5-39 and 5-40
4. Replace 9-3 thru 9-6
5. Replace 11-9 thru 11-12
6. Replace 12-1 and 12-2, 12-13 thru 12-20
7. Replace 16-3 and 16-4
8. Replace 20-3 thru 20-6, 20-13 and 20-14, 20-17 thru 20-20



**NOTE**

For STS-120 and subsequent flights

Prepared by:

  
Mission Lead  
Publication Manager

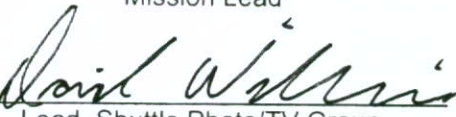
Approved by:

  
Lead, Shuttle Photo/TV Group  
Manager, Shuttle Procedures  
Management

Accepted by:

  
FDF Manager

Encl: 80 pages

**File this PCN immediately behind the front cover as a permanent record**





## MISSION OPERATIONS DIRECTORATE

**PHOTO/TV CHECKLIST**GENERIC, REVISION I  
June 5, 2007

PREPARED BY:



---

C. Pierce  
Publication Manager

APPROVED BY:

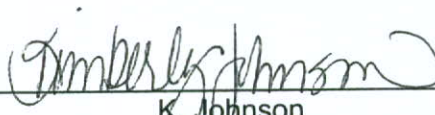

---

D. Williams  
Technical Lead, Shuttle Photo/TV Group

---

K. Johnson  
Manager, Shuttle Procedures Management

ACCEPTED BY:



---

Michael T. Hurt  
FDF Manager

This document is under the configuration control of the Crew Procedures Control Board (CPCB). All proposed changes must be submitted via FDF Workflow Crew Procedure Change Request (CR) to DO3/FDF Manager.

Additional distribution of this book, for official use only, may be requested in writing to DO3/PMO Administrator. The request must include justification and requester's name, organization, position, and phone number. Contractor requests are made through the NASA or DOD organization supported. Deletions, reduction in quantity, or change of address may be submitted to DO3/FDF Management Office, 281-244-1184.

Incorporates the following:	
482#:	P/TV-0710 P/TV-0711 P/TV-0712 P/TV-0713

AREAS OF TECHNICAL RESPONSIBILITY

Publication Manager	DO35/C. Pierce	281-483-6087
Backup Publication Manager	DO35/L. Giles	281-244-9068
Technical Lead, Shuttle Photo/TV Group	DX34/D. Williams	281-244-7882

PHOTO/TV CHECKLIST

**LIST OF EFFECTIVE PAGES**

GENERIC	11/13/87	PCN-4	08/22/08
REV I	06/05/07	PCN-5	10/17/08
PCN-1	09/14/07	PCN-6	05/20/09
PCN-2	11/07/07	PCN-7	09/30/09
PCN-3	04/04/08		

Sign Off .....	*	ALL/GEN I	4-29 .....	†	ALL/GEN I,6
ii.....	*	ALL/GEN I	4-30 .....	†	ALL/GEN I,6
iii.....	*	ALL/GEN I,7	4-31 .....	†	ALL/GEN I,6
iv.....	*	ALL/GEN I,7	4-32 .....	†	ALL/GEN I,6
v .....	*	ALL/GEN I,7	5-1 .....	†	ALL/GEN I,6
vi.....	*	ALL/GEN I,7	5-2 .....	†	ALL/GEN I,7
vii.....	*	ALL/GEN I,7	5-3 .....	†	ALL/GEN I,6
viii.....	*	ALL/GEN I	5-4 .....	†	ALL/GEN I,6
1-i.....		ALL/GEN I	5-5 .....	†	ALL/GEN I,6
1-ii .....		ALL/GEN I	5-6 .....	†	ALL/GEN I,6
1-1 .....	Δ	ALL/GEN I	5-7 .....	†⊗	ALL/GEN I,6
1-2 .....	Δ	ALL/GEN I	5-8 .....	†⊗	ALL/GEN I,6
2-1 .....	Δ	ALL/GEN I	5-9 .....	†⊗	ALL/GEN I,6
2-2 .....	Δ	ALL/GEN I	5-10 .....	†	ALL/GEN I,6
3-1 .....	Δ	ALL/GEN I	5-11 .....	†	ALL/GEN I,6
3-2 .....	Δ	ALL/GEN I	5-12 .....	†	ALL/GEN I,6
4-i.....		ALL/GEN I	5-13 .....	†⊗	ALL/GEN I,6
4-ii .....		ALL/GEN I	5-14 .....	†⊗	ALL/GEN I,6
4-1 .....	†	ALL/GEN I,6	5-15 .....	†⊗	ALL/GEN I,6
4-2 .....	†	ALL/GEN I,7	5-16 .....	†⊗	ALL/GEN I,6
4-3 .....	†	ALL/GEN I,6	5-17 .....	†	ALL/GEN I,6
4-4 .....	†	ALL/GEN I,6	5-18 .....	†	ALL/GEN I,6
4-5 .....	†⊗	ALL/GEN I,6	5-19 .....	†	ALL/GEN I,6
4-6 .....	†⊗	ALL/GEN I,6	5-20 .....	†	ALL/GEN I,6
4-7 .....	†⊗	ALL/GEN I,6	5-21 .....	†	ALL/GEN I,6
4-8 .....	†	ALL/GEN I,6	5-22 .....	†	ALL/GEN I,6
4-9 .....	†	ALL/GEN I,6	5-23 .....	†	ALL/GEN I,6
4-10 .....	†	ALL/GEN I,6	5-24 .....	†	ALL/GEN I,6
4-11 .....	†	ALL/GEN I,6	6-1 .....	†	ALL/GEN I
4-12 .....	†	ALL/GEN I,6	6-2 .....	†	ALL/GEN I
4-13 .....	†	ALL/GEN I,6	6-3 .....	†	ALL/GEN I
4-14 .....	†	ALL/GEN I,6	6-4 .....	†	ALL/GEN I
4-15 .....	†	ALL/GEN I,6	6-5 .....	†⊗	ALL/GEN I
4-16 .....	†	ALL/GEN I,6	6-6 .....	†⊗	ALL/GEN I
4-17 .....	†	ALL/GEN I,6	6-7 .....	†	ALL/GEN I
4-18 .....	†	ALL/GEN I,6	6-8 .....	†	ALL/GEN I
4-19 .....	†	ALL/GEN I,6	6-9 .....	†	ALL/GEN I
4-20 .....	†	ALL/GEN I,6	6-10 .....	†	ALL/GEN I
4-21 .....	†	ALL/GEN I,6	6-11 .....	†	ALL/GEN I
4-22 .....	†⊗	ALL/GEN I,6	6-12 .....	†	ALL/GEN I
4-23 .....	†⊗	ALL/GEN I,6	6-13 .....	†	ALL/GEN I
4-24 .....	†⊗	ALL/GEN I,6	6-14 .....	†	ALL/GEN I
4-25 .....	†⊗	ALL/GEN I,6	6-15 .....	†	ALL/GEN I
4-26 .....	†⊗	ALL/GEN I,6	6-16 .....	†	ALL/GEN I
4-27 .....	†⊗	ALL/GEN I,6	6-17 .....	†	ALL/GEN I
4-28 .....	†⊗	ALL/GEN I,6	6-18 .....	†	ALL/GEN I

- \* – Omit from flight book
- Δ – Replace with pages from Flight Supplement
- † – May be replaced with CD in flight book only
- ⊗ – Flight copies of this page contain color

7-1	†	ALL/GEN I,7	10-19	†	ALL/GEN I
7-2	†	ALL/GEN I,7	10-20	†	ALL/GEN I
7-3	†	ALL/GEN I,6	10-21	†	ALL/GEN I
7-4	†	ALL/GEN I,6	10-22	†	ALL/GEN I
7-5	†	ALL/GEN I,6	10-23	†	ALL/GEN I
7-6	†	ALL/GEN I,6	10-24	†	ALL/GEN I
7-7	†⊗	ALL/GEN I,6	10-25	†	ALL/GEN I
7-8	†	ALL/GEN I,6	10-26	†	ALL/GEN I
7-9	†	ALL/GEN I,6	11-1	†	ALL/GEN I
7-10	†	ALL/GEN I,6	11-2	†	ALL/GEN I,2
7-11	†	ALL/GEN I,6	11-3	†	ALL/GEN I
7-12	†	ALL/GEN I,6	11-4	†	ALL/GEN I
7-13	†	ALL/GEN I,6	11-5	†	ALL/GEN I,2
7-14	†	ALL/GEN I,6	11-6	†	ALL/GEN I,2
7-15	†⊗	ALL/GEN I,7	11-7	†	ALL/GEN I,2
7-16	†	ALL/GEN I,7	11-8	†	ALL/GEN I,2
7-17	†	ALL/GEN I,7	11-9	†	ALL/GEN I
7-18	†	ALL/GEN I,7	11-10	†	ALL/GEN I,3
7-18a	†	ALL/GEN I,7	11-11	†⊗	ALL/GEN I,1
7-18b	†	ALL/GEN I,7	11-12	†	ALL/GEN I,1
7-19	†	ALL/GEN I,6	12-1	†	ALL/GEN I,1
7-20	†	ALL/GEN I,6	12-2	†	ALL/GEN I
7-21	†	ALL/GEN I,6	12-3	†	ALL/GEN I
7-22	†	ALL/GEN I,6	12-4	†	ALL/GEN I
7-23	†⊗	ALL/GEN I,6	12-5	†	ALL/GEN I
7-24	†⊗	ALL/GEN I,7	12-6	†	ALL/GEN I
8-1	†	ALL/GEN I	12-7	†	ALL/GEN I
8-2	†	ALL/GEN I,7	12-8	†	ALL/GEN I
8-3	†	ALL/GEN I	12-9	†	ALL/GEN I
8-4	†	ALL/GEN I	12-10	†	ALL/GEN I
8-5	†	ALL/GEN I	12-11	†	ALL/GEN I
8-6	†	ALL/GEN I	12-12	†	ALL/GEN I
9-1	†	ALL/GEN I,7	12-12a	†	ALL/GEN I,6
9-2	†	ALL/GEN I,7	12-12b	†	ALL/GEN I,6
9-3	†⊗	ALL/GEN I,7	12-13	†	ALL/GEN I,1
9-4	†⊗	ALL/GEN I,7	12-14	†⊗	ALL/GEN I,1
9-5	†	deleted	12-15	†	ALL/GEN I,1
9-6	†	deleted	12-16	†	ALL/GEN I,7
10-1	†	ALL/GEN I	12-17	†	ALL/GEN I,7
10-2	†	ALL/GEN I	12-18	†	ALL/GEN I,1
10-3	†	ALL/GEN I	12-19	†	ALL/GEN I,1
10-4	†	ALL/GEN I	12-20	†	ALL/GEN I,1
10-5	†	ALL/GEN I	13-1	†	ALL/GEN I
10-6	†⊗	ALL/GEN I	13-2	†	ALL/GEN I
10-7	†	ALL/GEN I	13-3	†	ALL/GEN I
10-8	†	ALL/GEN I	13-4	†⊗	ALL/GEN I,7
10-9	†	ALL/GEN I	13-5	†⊗	ALL/GEN I
10-10	†	ALL/GEN I	13-6	†⊗	ALL/GEN I
10-11	†	ALL/GEN I	13-7	†⊗	ALL/GEN I
10-12	†	ALL/GEN I	13-8	†⊗	ALL/GEN I
10-13	†	ALL/GEN I	13-9	†	ALL/GEN I
10-14	†	ALL/GEN I	13-10	†	ALL/GEN I
10-15	†	ALL/GEN I	13-11	†	ALL/GEN I
10-16	†	ALL/GEN I	13-12	†	ALL/GEN I
10-17	†	ALL/GEN I	14-1	†	ALL/GEN I
10-18	†	ALL/GEN I	14-2	†	ALL/GEN I

† – May be replaced with CD in flight book only

⊗ – Flight copies of this page contain color

14-3	†	ALL/GEN I	20-13	†	ALL/GEN I,7
14-4	†	ALL/GEN I	20-14	†	ALL/GEN I,7
15-1	†	ALL/GEN I	20-15	†⊗	ALL/GEN I,7
15-2	†	ALL/GEN I	20-16	†	ALL/GEN I,7
15-3	†	ALL/GEN I	20-17	†	ALL/GEN I,7
15-4	†	ALL/GEN I	20-18	†⊗	ALL/GEN I,7
15-5	†	ALL/GEN I	20-19	†	ALL/GEN I,7
15-6	†	ALL/GEN I	20-20	†	ALL/GEN I,7
15-7	†	ALL/GEN I	20-21	†	ALL/GEN I,7
15-8	†	ALL/GEN I	20-22	†	ALL/GEN I,7
15-9	†	ALL/GEN I	21-1	†	ALL/GEN I
15-10	†	ALL/GEN I	21-2	†	ALL/GEN I,7
15-11	†	ALL/GEN I			
15-12	†	ALL/GEN I			
15-13	†	ALL/GEN I			
15-14	†	ALL/GEN I			
15-15	†	ALL/GEN I			
15-16	†	ALL/GEN I			
16-1	†	ALL/GEN I,7			
16-2	†	ALL/GEN I			
16-3	†	ALL/GEN I,7			
16-4	†	ALL/GEN I,7			
16-5	†	ALL/GEN I,7			
16-6	†	ALL/GEN I,7			
17-1	†	ALL/GEN I			
17-2	†	ALL/GEN I			
18-1	†	ALL/GEN I			
18-2	†	ALL/GEN I			
18-3	†	ALL/GEN I			
18-4	†	ALL/GEN I			
18-5	†	ALL/GEN I			
18-6	†	ALL/GEN I			
19-1	†	ALL/GEN I			
19-2	†	ALL/GEN I			
19-3	†	ALL/GEN I			
19-4	†	ALL/GEN I			
19-5	†	ALL/GEN I			
19-6	†	ALL/GEN I			
19-7	†	ALL/GEN I			
19-8	†	ALL/GEN I			
19-9	†	ALL/GEN I			
19-10	†	ALL/GEN I			
19-11	†	ALL/GEN I			
19-12	†	ALL/GEN I			
20-1	†	ALL/GEN I,7			
20-2	†	ALL/GEN I,7			
20-3	†	ALL/GEN I,7			
20-4	†	ALL/GEN I,7			
20-5	†	ALL/GEN I,7			
20-6	†	ALL/GEN I,7			
20-7	†	ALL/GEN I,7			
20-8	†	ALL/GEN I,7			
20-9	†	ALL/GEN I,7			
20-10	†	ALL/GEN I,7			
20-11	†	ALL/GEN I,7			
20-12	†	ALL/GEN I,7			

† – May be replaced with CD in flight book only

⊗ – Flight copies of this page contain color

This Page Intentionally Blank

## TABLE OF CONTENTS

	<u>PAGE</u>
<u>FLIGHT SPECIFIC</u>	
<u>SCENES</u> .....	flt suppl
<u>REFERENCED PROCEDURES</u> .....	flt suppl
<u>CUE CARD CONFIGURATION</u> .....	flt suppl
<u>GENERIC</u>	
<u>NIKON D2Xs</u> .....	4-1
<u>D2Xs EVA CAMR</u> .....	5-1
<u>EVA IR CAMR</u> .....	6-1
<u>CANON G1</u> .....	7-1
<u>SONY V10</u> .....	8-1
<u>PORTABLE MONITORS</u> .....	9-1
<u>CCTV</u> .....	10-1
<u>CENTERLINE (C/L) CAMR</u> .....	11-1
<u>DTV</u> .....	12-1
<u>BPSMU</u> .....	13-1
<u>MINI-CAM</u> .....	14-1
<u>WIRELESS VIDEO SYSTEM (WVS)</u> .....	15-1
<u>SEQUENTIAL STILL VIDEO (SSV)</u> .....	16-1
<u>BINOCULARS</u> .....	17-1
<u>FIBERSCOPE</u> .....	18-1
<u>LASER DYNAMIC RANGE IMAGER (LDRI)</u> .....	19-1
<u>LASER CAMR SYSTEM (LCS)/INTEGRATED SENSOR INSPECTION SYSTEM DIGITAL CAMR (IDC)</u> .....	20-1
<u>BATTS &amp; FUSES</u> .....	21-1

This Page Intentionally Blank





This Page Intentionally Blank

Replace this page with section 1 of the Flight Supplement

I

This Page Intentionally Blank

Replace this page with section 2 of the Flight Supplement

I

This Page Intentionally Blank

Replace this page with section 3 of the Flight Supplement

I

This Page Intentionally Blank



NOTE

The hardcopy version of sections 4 thru 21 may be replaced with a CD for flight and inserted in the back of the PHOTO/TV flight-supplement flight book

This Page Intentionally Blank

## NIKON D2Xs

	<u>PAGE</u>
SPECIFICATIONS.....	4-2
CAMR BODY .....	4-2
FLASH .....	4-2
LENS DATA.....	4-3
NOMENCLATURE.....	4-4
CAMR MENU.....	4-12
NOMINAL SETUP .....	4-22
DATE/TIME SET.....	4-29
DELETING SINGLE IMAGES.....	4-29
ADDING .WAV FILES TO AN IMAGE .....	4-29
DELETING .WAV FILE FROM AN IMAGE .....	4-29
.WAV FILE PLAYBACK .....	4-30
IMAGE FILE TRANSFER.....	4-30
DNLK FROM FLASH CARD .....	4-30
DCS FILE TO HARD DRIVE.....	4-30
RECOVER LOST IMAGES.....	4-31

D2Xs

**SPECIFICATIONS**

CAMR BODY

CMOS SENSOR SIZE: 23.7mm x 15.7mm  
PIXEL COUNT: 4288 x 2848  
DISK/FRAME: 1 GB, ~90 frames; 4 GB, ~360 frames  
RAW FILE SIZE: ~10 MB (compressed)  
EXPOSURE CONTROL: Auto (program, shutter priority, aperture priority), Manual  
METER PATTERN: 3D Color Matrix, Center Weighted, Spot  
EXPOSURE COMP:  $\pm 5$  in 1, 1/3, 1/2 EV steps  
SHUTTER:  
    Program & Aperture Priority – 1/8000 thru 30 sec (virtually stepless)  
    Manual & Shutter Priority – 1/8000 thru 30 sec (1,1/3,1/2) stop increments), 250x, and Bulb (manual only)  
ISO Setting: 100-3200; >800 controlled by menu  
FRAME RATE: Single, C<sub>H</sub> – 5 fps, C<sub>L</sub> – 1-4 fps  
    Burst Rate: Mode dependent  
CAMR BATT: Li-ION EN-EL4A  
CAMR BATT VOLTAGE: 11.1VDC  
CAMR BATT LIFETIME: ~1000 frames  
CAMR WEIGHT: 2.4 lb (w/Batt & Memory Card)

FLASH

SB-28 DX  
    BATT: 4AA  
    BATT LIFETIME: 200+ images  
    WEIGHT: w/o Batts – 0.85 lb  
  
SB-800 DX  
    BATT: 4AA  
    BATT LIFETIME: 200+ images  
    WEIGHT: w/o Batts – .77 lb

## D2Xs (Continued)

### LENS DATA

NOTE

Do not use non-AF lens w/D2Xs

Lens	Aperture Range (f/stop)	Approximate Field of View (FOV)			Approx Minimum Focus Distance (ft)	Weight (lb)	Filter Size	M-A Switch
		Horizontal	Vertical	Diagonal				
10.5mm AF DXG	f/2.8-f/22	–	–	180°	0.5	.67	Rear	
12-24mm AF DXG	f/4.0-f/22	89°-53°	66°-36°	100°-61°	1.0	1.02	77mm	Yes
16mm AF	f/2.8-f/22	73°	52°	83°	1.0	0.69	Rear	
17-35mm AFD	f/2.8-f/22	70°-37°	50°-25°	80°-44°	1.0	1.64	77mm	Yes
20mm AF	f/2.8-f/22	61°	43°	71°	0.85	0.62	62mm	
20-35mm AFD	f/2.8-f/22	61°-37°	43°-25°	71-44°	1.7	1.36	77mm	Yes
28mm AF	f/2.8-f/22	46°	31°	54°	1.25	0.46	52mm	
28mm AFD	f/1.4-f/16	46°	31°	54°	1.14	1.15	72mm	Yes
28-70mm AFD	f/2.8-f/22	46°-19°	31°-13°	54°-23°	2.3 (1.5 ft macro)	1.95	77mm	Yes
35mm AF	f/2.0-f/22	37°	25°	44°	0.9	0.51	52mm	
24-50mm AF	f/3.3(4.5)-f/22	52°-27°	36°-18°	61°-32°	2.0 (1.6 ft macro)	0.86	62mm	
35-70mm AF	f/2.8-f/22	37°-19°	25°-13°	44°-23°	2.0 (0.9 ft macro)	1.5	62mm	
50mm AFD	f/1.4-f/16	27°	18°	32°	1.5	0.59	52mm	
60mm AF	f/2.8-f/32	22°	15°	27°	0.73	0.93	62mm	Yes
85mm AF	f/1.4-f/16	16°	11°	19°	2.8	1.23	77mm	Yes
105mm AF	f/2.8-f/32	13°	9°	15°	1.0	1.22	52mm	Yes
180mm AFD	f/2.8-f/22	8°	5°	9°	5.0	1.72	72mm	Yes
80-200mm AFD	f/2.8-f/22	16°-7°	11°-4.5°	20°-8°	6.0	2.98	77mm	Yes
300mm AF	f/2.8-f/22	4°	3°	5°	10.0	6.36	39mm	Yes
400mm AFD	f/2.8-f/22	3.4°	2.2°	4.1°	9.75	10.58	52mm	Yes

## D2Xs (Continued)

### NOMENCLATURE

#### CAMR – FRONT

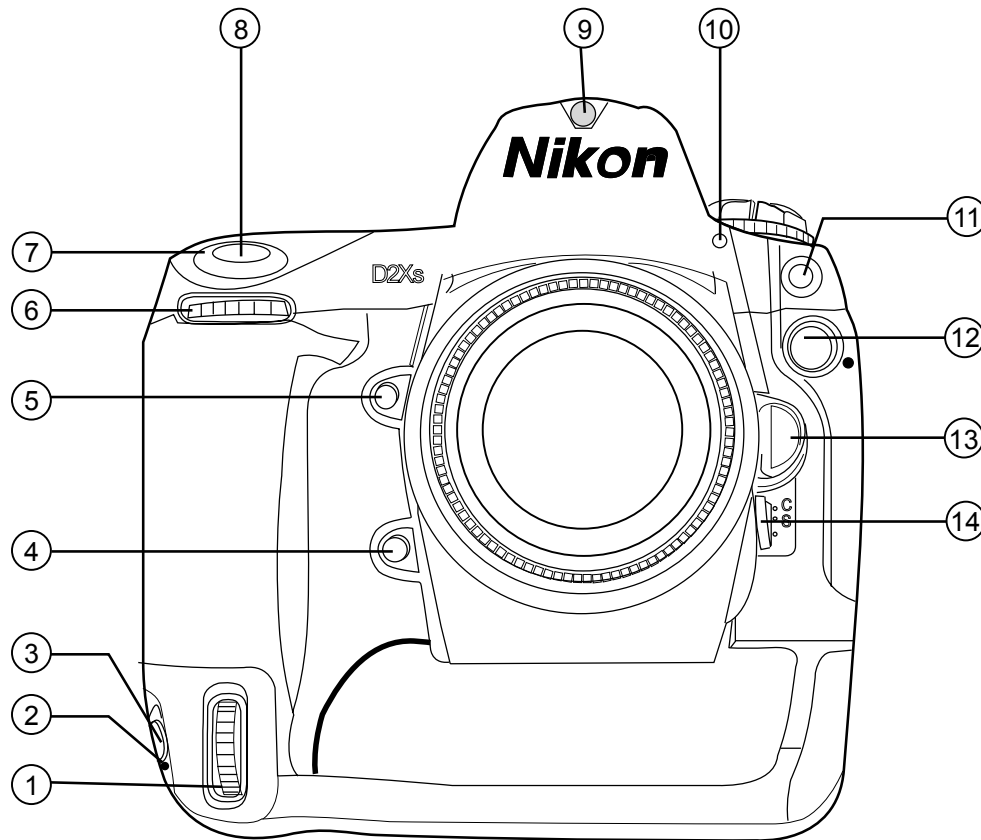

- ① Vertical Shooting Sub-command Dial
- ② Vertical Shooting Shutter-release Lock pb
- ③ Vertical Shooting Shutter-release pb
- ④ Function pb
- ⑤ Depth-of-field Preview pb
- ⑥ Sub-command Dial
- ⑦ Power sw
- ⑧ Shutter Release pb
- ⑨ Ambient Light Sensor
- ⑩ Self-timer LED
- ⑪ Flash Sync Terminal
- ⑫ 10-pin Remote Terminal
- ⑬ Lens Release pb
- ⑭ Focus mode Selector

jsc48037\_152.cvx

## D2Xs (Continued)

### NOMENCLATURE (Continued)

#### CAMR – BACK

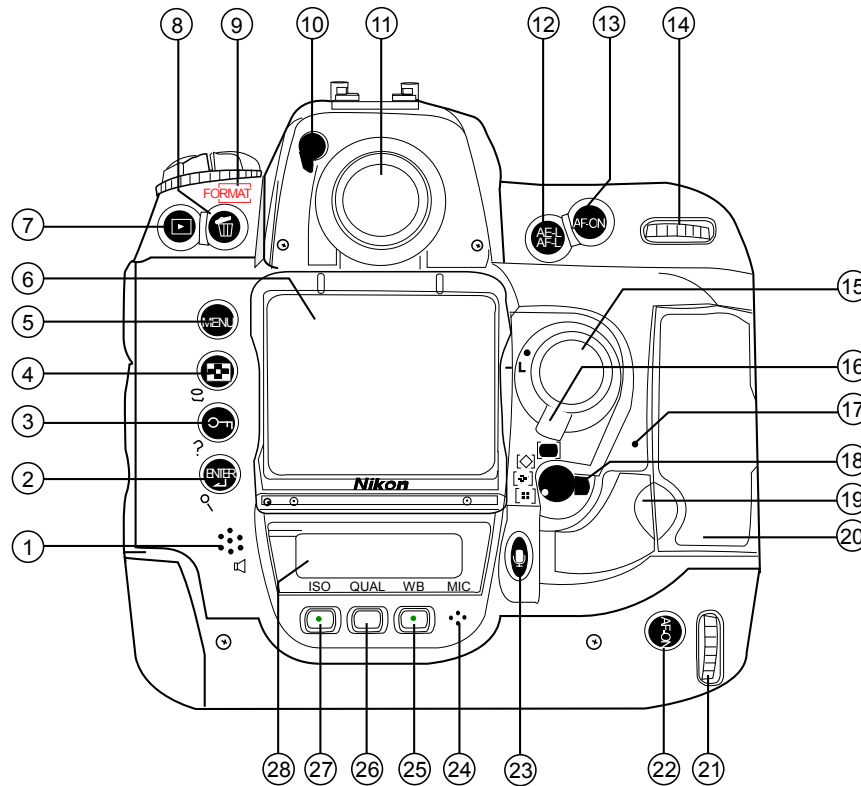

- ① Speaker
- ② ENTER (ENTER)/Playback Zoom (Z) pb
- ③ Protect (P)/HELP (?) pb
- ④ Thumbnail (T) pb
- ⑤ MENU (MENU) pb
- ⑥ Monitor
- ⑦ Playback (P) pb
- ⑧ Delete (X) pb
- ⑨ FORMAT (FORMAT) pb
- ⑩ Eyepiece Shutter Lever
- ⑪ Viewfinder Eyepiece
- ⑫ AE/AF Lock (AE-L) pb
- ⑬ AF-ON (AF-ON) pb
- ⑭ Main Command Dial
- ⑮ Multi Selector
- ⑯ Focus Selector Lock
- ⑰ Memory Card Access Lamp
- ⑱ AF-area Mode Selector
- ⑲ Card-slot Cover Release Button (under Cover)
- ⑳ Memory Card Slot Cover
- ㉑ Main Command Dial for Vertical Shooting
- ㉒ AF-ON (AF-ON) for Vertical Shooting pb
- ㉓ Microphone (MIC) pb
- ㉔ Microphone
- ㉕ White Balance (WB) pb
- ㉖ Image Quality/Size (QUAL) pb
- ㉗ ISO Sensitivity (ISO) pb
- ㉘ Rear Control Panel

JSC48037\_153.cvx

## D2Xs (Continued)

### NOMENCLATURE (Continued)

#### CAMR – TOP

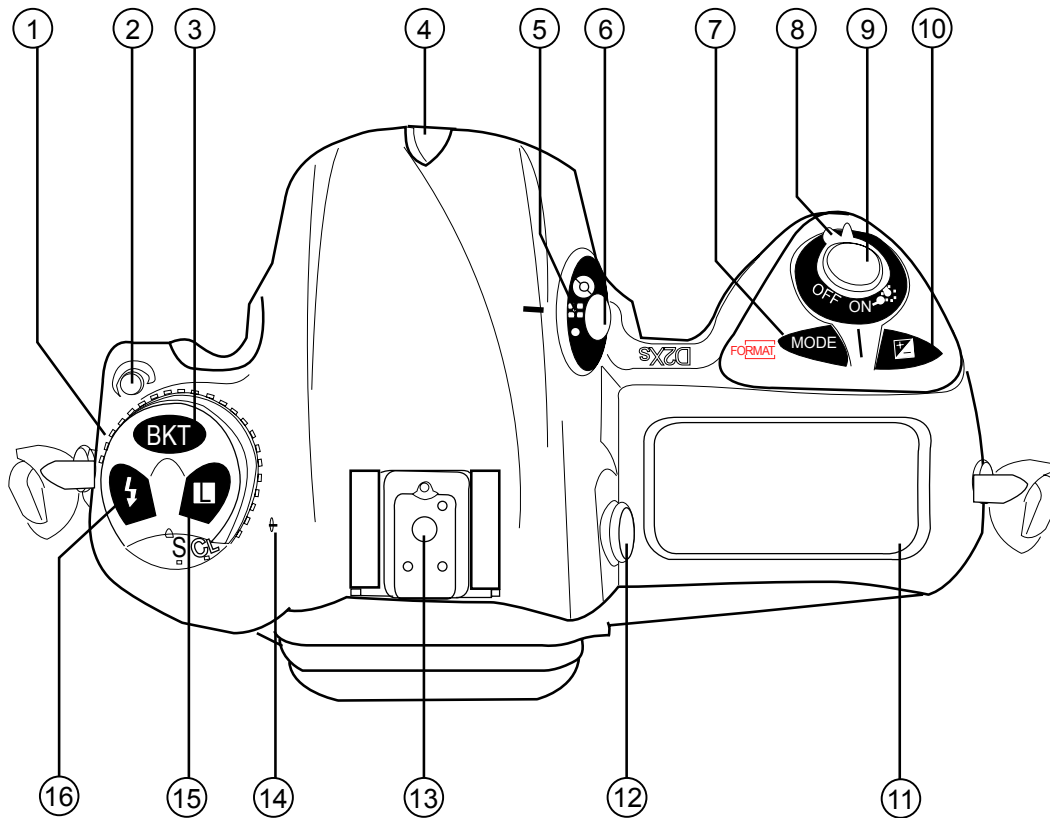

- ① Shooting Mode Dial
- ② Shooting Mode Dial Lock Release
- ③ Bracket ( **BKT** ) pb
- ④ Ambient Light Sensor
- ⑤ Meter Selector
- ⑥ Meter Selector Lock pb
- ⑦ Exposure Mode ( **MODE** ) / Format ( **FORMAT** ) pb
- ⑧ Power sw
- ⑨ Shutter-release pb
- ⑩ Exposure Compensation ( **▾** ) pb
- ⑪ Top LCD
- ⑫ Diopter Adjustment Knob
- ⑬ Accessory Shoe
- ⑭ Focal Plane Mark ( **↔** )
- ⑮ Lock ( **⏏** ) pb
- ⑯ Flash Sync Mode ( **⚡** ) pb

jsc48037\_154.cvx



## D2Xs (Continued)

### NOMENCLATURE (Continued)

#### CAMR – LEFT SIDE

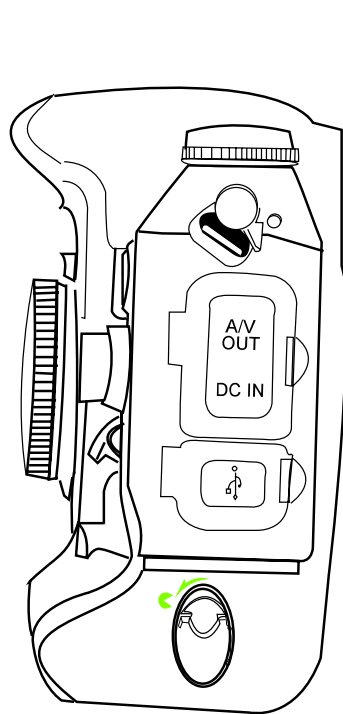

Housing Doors Closed

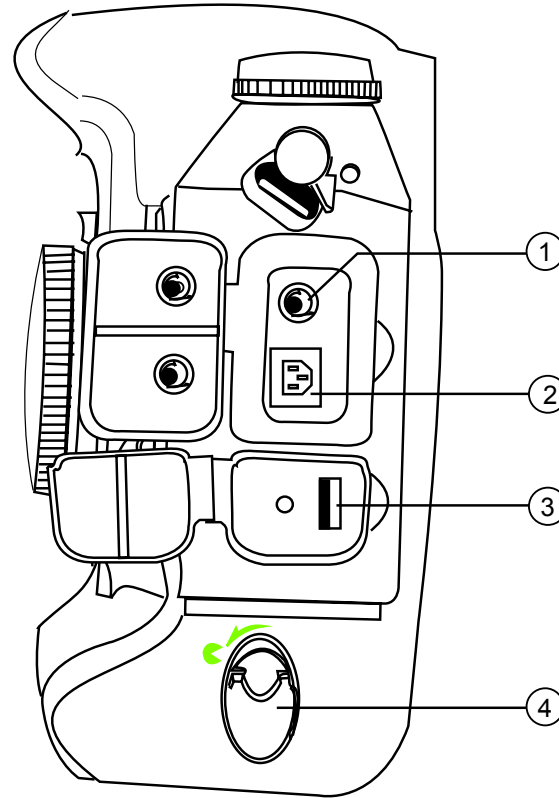

Housing Doors Open

- ① Audio/video (A/V) Connector
- ② DC-in Connector
- ③ USB Connector
- ④ Battery Cover Latch

jsc48037\_155.cvx

## D2Xs (Continued)

### NOMENCLATURE (Continued)

#### CAMR – TOP CONTROL PANEL

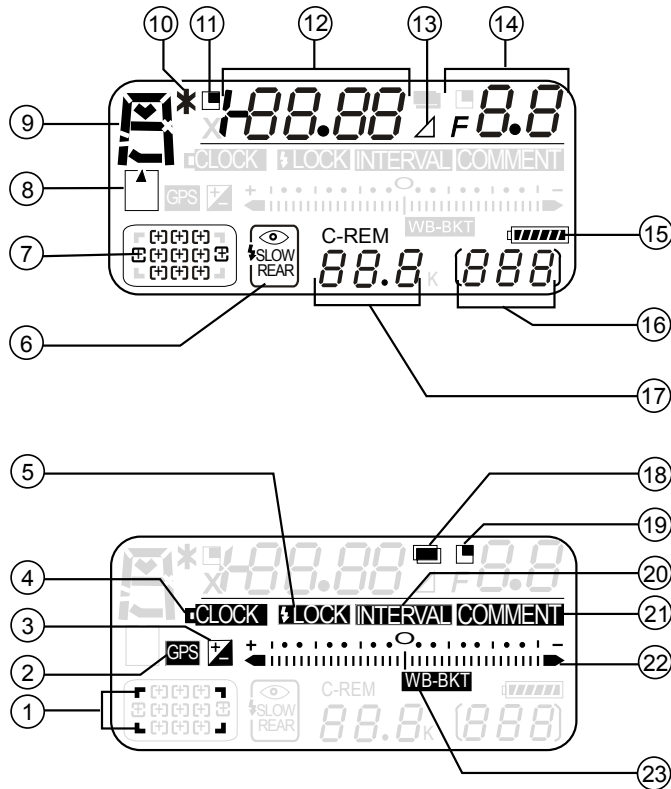

- ① High Speed Crop
- ② GPS Connection
- ③ Exposure Compensation
- ④ Clock Battery
- ⑤ Flash Exposure Lock
- ⑥ Flash Sync Mode
- ⑦ AF Area Mode
- ⑧ Memory Card
- ⑨ Exposure Mode
- ⑩ Flexible Program
- ⑪ Shutter Speed Lock Icon
- ⑫ Shutter Speed  
Exposure Compensation Value
- ⑬ Aperture Delta
- ⑭ Aperture (f/number)
- ⑮ Battery
- ⑯ Frame Count
- ⑰ Number of Remaining Exposures
- ⑱ Multiple Exposure
- ⑲ Aperture Lock Icon
- ⑳ Interval Timer
- ㉑ Image Comment
- ㉒ Manual Exposure Meter  
Bracketing Progress Indicator
- ㉓ Bracketing Indicator

jsc48037\_156.cvx

## D2Xs (Continued)

### NOMENCLATURE (Continued)

#### CAMR – REAR CONTROL PANEL

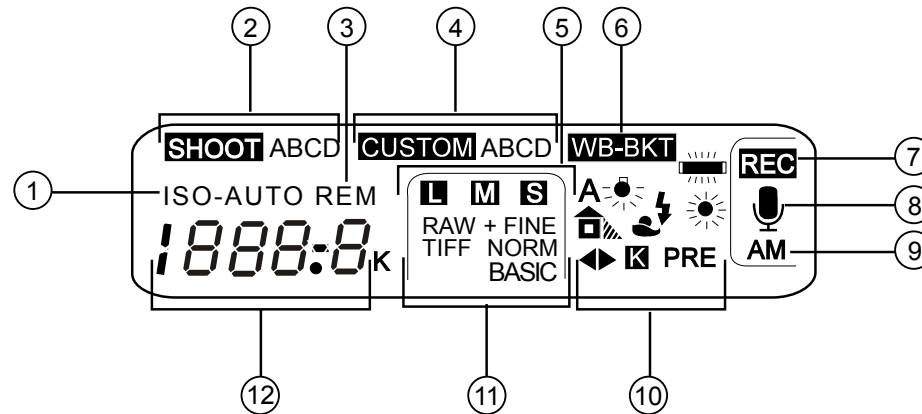

- |                                      |  |
|--------------------------------------|--|
| ① ISO Sensitivity Indicator          | ⑦ Voice Memo Recording Indicator (Shooting Mode) |
| ② Shooting Menu Settings Bank        | ⑧ Voice Memo Status Indicator                    |
| ③ Remaining Exposure Indicator       | ⑨ Voice Memo Recording Mode                      |
| ④ Custom Settings Bank               | ⑩ White Balance Mode                             |
| ⑤ Image Size                         | ⑪ Image Quality                                  |
| ⑥ White Balance Bracketing Indicator | ⑫ ISO Sensitivity Length of Voice Memo           |

jsc48037\_157.cvx

## D2Xs (Continued)

### NOMENCLATURE (Continued)

#### VIEWFINDER DISPLAY – LOWER BAR

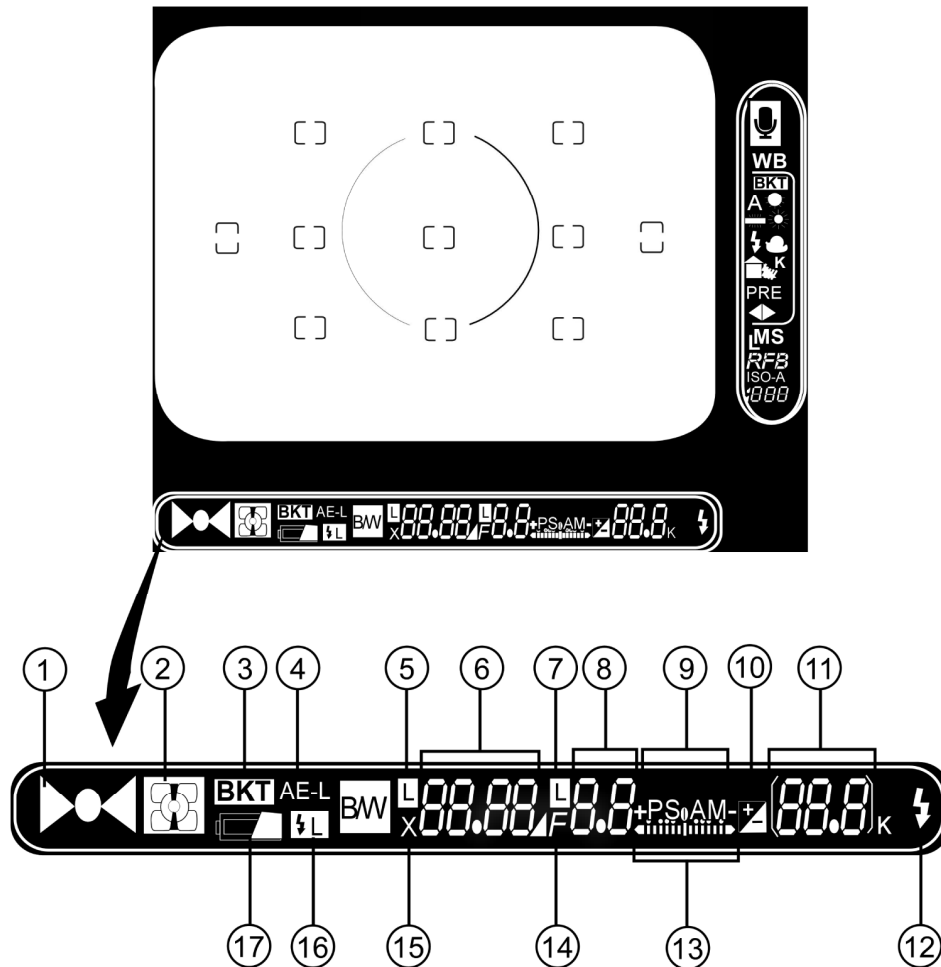

- ① Focus Indicator
- ② Metering
- ③ Bracketing Indicator
- ④ Autoexposure (AE) Lock
- ⑤ Shutter Speed Lock Icon
- ⑥ Shutter Speed
- ⑦ Aperture Lock Icon
- ⑧ Aperture (f/number)
- ⑨ Exposure Mode
- ⑩ Exposure Compensation Indicator
- ⑪ Frame Counter
- ⑫ Flash Ready Indicator
- ⑬ Electronic Analog Exposure Display
- ⑭ Aperture Stop Indicator
- ⑮ Sync Indicator
- ⑯ FV Lock Indicator
- ⑰ Battery Indicator

jsc48037\_158.cvx



## D2Xs (Continued)

### CAMR MENU

Level 1	Level 2	Level 3	Level 4	Level 5	
PLAYBACK MENU	Delete	Selected	<i>Choose Image</i>		
		All			
	Playback folder	ND2XS			
		All			
		Current			
	Slide show	Start			
		Frame interval	2 s		
			3 s		
			5 s		
			10 s		
		Audio playback	Off		
	On			Frame interval	
				Length of voice memo	
	Hide image	Select/set	<i>Choose Image</i>		
		Deselect all?	No		
			Yes		
	Print set	Select/set	<i>Choose Image</i>		
		Deselect all?	No		
			Yes		
	Display mode	Done			
		Data			
		Histogram			
		Highlight			
RGB histogram					
Focus area					
Image review	Off				
	On				
After delete	Show next				
	Show previous				
	Continue as before				
Rotate tall	Off				
	On				

## D2Xs (Continued)

### CAMR MENU (Continued)

Level 1	Level 2	Level 3	Level 4	Level 5		
SHOOTING MENU	Shooting menu bank	A				
		B				
		C				
		D				
		Rename				
	Reset shooting menu	No				
		Yes				
	Active folder	New				<i>Pick number</i>
		Select folder				<i>Choose folder</i>
	File naming	File naming				<i>Create name</i>
	Image quality	NEF(RAW) + JPEG fine				
		NEF(RAW) + JPEG normal				
		NEF(RAW) + JPEG basic				
		NEF (RAW)				
		TIFF (RGB)				
		JPEG fine				
		JPEG normal				
		JPEG basic				
	Image size	Large				
		Medium				
		Small				
	High speed crop	Off				
		On				
JPEG Compression	Size priority					
	Optimal quality					

D2Xs (Continued)

CAMR MENU (Continued)

Level 1	Level 2	Level 3	Level 4	Level 5		
SHOOTING MENU (Continued)	RAW Compression	Off NEF(RAW)				
		On Comp, NEF(RAW)				
	White balance	Auto				
		Incandescent				
		Fluorescent				
		Direct sunlight				
		Flash				
		Cloudy				
		Shade				
		Choose color temp				
	White balance preset			<i>Select preset</i>	Set	
					Edit comment	
					Select image	
					Copy d-0	
	Long exp. NR	Off				
		On				
	High ISO NR	On (normal)				
		On (high)				
		OFF				
	ISO sensitivity	<i>Select ISO</i>				
	Image Sharpening	Auto				
		Normal				
		Low				
Medium Low						
Medium High						
None						



**D2Xs (Continued)**

**CAMR MENU (Continued)**

Level 1	Level 2	Level 3	Level 4	Level 5	
SHOOTING MENU (Continued)	Tone compensation	Auto			
		Normal			
		Less contrast			
		More contrast			
		Custom 1			
		Custom 2			
		Custom 3			
	Color space	sRGB			
		Adobe RGB			
	Color mode	I			
		II			
		III			
		Black-and-white (sRGB)			
	Hue adjustment	<i>Select adjustment</i>			
	Image overlay	<i>Select images</i>			
	Multiple Exposure	Done			
		Number of shots			
		Auto gain			On
					Off
	Trim	<i>Select Image</i>			
	Intvl timer Shooting	Status			
Start		Now			
		Start time			
Current time					
Start time		<i>Adjust</i>			
Interval		Set Interval			

D2Xs (Continued)

CAMR MENU (Continued)

Level 1	Level 2	Level 3	Level 4	Level 5	
SHOOTING MENU (Concluded)	Intvl timer Shooting (Concluded)	Select intvl x no. of shots	Select no. of Intervals & shots		
		Remaining (Intvl x shots)	Off		
			On		
	Non-CPU lens data	Focal length (mm)	N/A		
			6-45mm		
			50-180mm		
		200-4000mm			
	Maximum aperture	Select aperture			
CUSTOM SETTINGS MENU	Bank select	A			
		B			
		C			
		D			
		Rename			
	Menu reset	No			
		Yes			
	a Autofocus	a1 AF-C mode priority		fps rate	
				fps rate + AF	
				Focus	
		a2 AF-S mode priority		Focus	
				Release	
		a3 Group dynamic AF		Pattern 1	Center area
					Closest subject
				Pattern 2	Center area
			Closest subject		
a4 Lock-On	Long				
	Normal				
	Short				
	Off				

**D2Xs (Continued)**

**CAMR MENU (Continued)**

Level 1	Level 2	Level 3	Level 4	Level 5	
CUSTOM SETTINGS MENU (Continued)	a Autofocus (Concluded)	a5 AF activation	Shutter/AF-ON		
			AF-ON only		
		a6 Focus area illum	Manual focus mode		On
					Off
			Continuous mode		On
					Off
		When selected			9.2 s
					1 s
		a7 Focus area	No wrap		
			Wrap		
	a8 Vertical AF-ON	AF-ON+focus Area			
		AF-ON			
		AE/AF-L+Focus area			
		AE/AF-L			
	Focus area				
	b Metering/exposure	b1 ISO auto	Off		
			On		
			Max. sensitivity	200	
				400	
			800		
			Min. shutter speed	<i>Select shutter speed</i>	
		b2 ISO step value	1/3 step		
			1/2 step		
			1 step		
b3 EV step		1/3 step			
		1/2 step			
		1 step			
b4 Exposure comp. EV		1/3 step			
		1/2 step			
	1 step				

**D2Xs (Continued)**

**CAMR MENU (Continued)**

Level 1	Level 2	Level 3	Level 4	Level 5
CUSTOM SETTINGS MENU (Continued)	b Metering/exposure (Concluded)	b5 Exposure comp.	Off	
			On	
			On (auto reset)	
		b6 Center- weight	6mm	
			8mm	
			10mm	
			13mm	
			Average	
		b7 Fine tune exposure	No	
	Yes			
	c Timers/AE& AF lock	c1 AE lock	Off	
			On	
		c2 AE-L/AF-L	AF/AF lock	
			AE lock only	
			AE lock hold/ reset	
			AE lock hold	
			AF lock	
			AF-on	
		c3 Auto meter- off	4 s	
			6 s	
8 s				
16 s				
No limit				
c4 Self-timer	2 s			
	5 s			
	10 s			
	20 s			

D2Xs (Continued)

CAMR MENU (Continued)

Level 1	Level 2	Level 3	Level 4	Level 5	
CUSTOM SETTINGS MENU (Continued)	c Timers/AE& AF lock (Concluded)	c5 Monitor off	10 s		
			20 s		
			1 m		
			5 m		
			10 m		
	d Shooting/display	d1 Shooting speed	7 fps		
			6 fps		
			5 fps		
			4 fps		
			3 fps		
			2 fps		
			1 fps		
		d2 Maximum shots	<i>Select shots</i>		
		d3 Exp. delay mode	Off		
			On		
		d4 File no. seq.	Off		
			On		
			Reset		
		d5 Cntrl panel/ finder	Rear control panel		ISO sensitivity
			Viewfinder display		Exposures remaining
	d6 Illumination	Lamp on switch	Frame count		
		Any button	Exposures remaining		
	e Bracketing/flash	e1 Flash sync speed	<i>Select speed</i>		
<i>Select speed</i>					
e2 Flash shutter speed		On			
		Off			
e3 AA flash mode		On			
	Off				
e4 Modeling flash	On				
	Off				

**D2Xs (Continued)**

**CAMR MENU (Continued)**

Level 1	Level 2	Level 3	Level 4	Level 5
CUSTOM SETTINGS MENU (Continued)	e Bracketing/flash (Concluded)	e5 Auto BKT set	AE & flash	
			AE only	
			Flash only	
			WB bracketing	
		e6 Manual mode bkting	Flash/speed	
			Flash/speed/ aperture	
			Flash/aperture	
			Flash only	
		e7 Auto BKT order	MTR>under>over	
			Under>MTR>over	
		e8 Auto BKT selection	Manual value select	
			Preset value select	
	f Controls	f1 Center button	Shooting mode	Center AF area
				Illuminate AF area
				Not used
			Playback mode	Thumbnail on/off
				Histogram on/off
				Zoon on/off
		f2 Multi selector	Do nothing	
			Reset mtr-off delay	
			Initiate autofocus	
		f3 Photo info/playback	Off	
			On	
f4 FUNC. Button		None		
		FV lock		
		Same as AE-L/AF-L		
		Flash off		
		Bracketing burst		
	Matrix metering			
	Center-weighted			
	Spot metering			

D2Xs (Continued)



CAMR MENU (Concluded)



Level 1	Level 2	Level 3	Level 4	Level 5	
CUSTOM SETTINGS MENU (Concluded)	f Controls (Concluded)	f5 FUNC. + command	None		
			Hi-speed crop		
			1 step spd/aperture		
			Non-CPI lens data		
		f6 Command dials	Rotate direction		Normal
					Reverse
			Change main/sub		Off
					On
			Aperture setting		Sub-command dial
					Aperture ring
		f7 Buttons and dials	Menus and playback		Off
					On
			f8 No CF card?		
SET UP MENU	Audio Output	Via speaker	Select output level		
		Via video out			
		OFF			
	USB	Mass storage			
		PTP			
	Dust off ref photo	Start			
	Battery info				
	Wireless LAN				
	Image authentication	Off			
		On			
	Save/load settings	Save settings			
		Load settings			
	Firmware version				
RECENT SETTINGS	Select Setting				

## D2Xs (Continued)



### NOMINAL SETUP

#### D2Xs PROGRAM w/FLASH

Lens – as reqd  
Aperture – Min, locked  
Body Focus Mode – S  
√Batt installed  
√Flash Card installed  
Pwr – ON  
Top LCD  
  √Batt  
  √Frames remaining sufficient  
Exp Comp (  ) – 0.0  
Exp Mode – P  
Meter – Matrix (  )  
Diopter – Adjust  
Frame Rate – S  
√BKT disabled – 0 F  
Rear LCD  
  √ISO – 100  
  √QUAL – RAW  
  √WB – 0,A  
AF Area Mode – [ [ ] ]  
√Focus Area – Center  
√Focus Selector Lock – L

SB-800 Flash Settings  
  √Diffuser Dome installed  
  ON/OFF pb – ON  
  √MODE –     
  √Exp Comp – 0 EV  
  Tilt – 45° (Direct)

#### D2Xs SHUTTER PRIORITY (EARTH OBS)

Lens – as reqd  
Aperture – Min, locked  
Body Focus Mode – S  
√Batt installed  
√Flash Card installed  
Pwr – ON  
Top LCD  
  √Batt  
  √Frames remaining sufficient  
Exp Comp (  ) – 0.0  
Exp Mode – S  
  SS – 500  
Meter – Matrix (  )  
Diopter – Adjust  
Frame Rate – S  
√BKT disabled – 0 F  
Rear LCD  
  √ISO – 100  
  √QUAL – RAW  
  √WB – 0,A  
AF Area Mode – [ [ ] ]  
√Focus Area – Center  
√Focus Selector Lock – L



SB-800 Flash Settings  
  ON/OFF pb – OFF



## D2Xs (Continued)



### NOMINAL SETUP (Continued)

#### D2Xs APERTURE PRIORITY

Lens – as reqd  
Aperture – Min, locked  
Body Focus Mode – S  
√Batt installed  
√Flash Card installed  
Pwr – ON  
Top LCD  
√Batt  
√Frames remaining sufficient  
Exp Comp (  ) – 0.0  
Exp Mode – A  
f/stop – as reqd  
Meter – Matrix (  )  
Diopter – Adjust  
Frame Rate – S  
√BKT disabled – 0 F  
Rear LCD  
√ISO – 100  
√QUAL – RAW  
√WB – 0,A  
AF Area Mode – [ [ ] ]  
√Focus Area – Center  
√Focus Selector Lock – L

SB-800 Flash Settings  
√Diffuser Dome installed  
ON/OFF pb – ON  
√MODE –  TTL BL  
√Exp Comp – 0 EV  
Tilt – 45° (Direct)

#### D2Xs MANUAL



Lens – as reqd  
Aperture – Min, locked  
Body Focus Mode – S  
√Batt installed  
√Flash Card installed  
Pwr – ON  
Top LCD  
√Batt  
√Frames remaining sufficient  
Exp Comp (  ) – 0.0  
Exp Mode – M  
SS – as reqd  
f/stop – as reqd  
Meter – Matrix (  )  
Diopter – Adjust  
Frame Rate – S  
√BKT disabled – 0 F  
Rear LCD  
√ISO – 100  
√QUAL – RAW  
√WB – 0,A  
AF Area Mode – [ [ ] ]  
√Focus Area – Center  
√Focus Selector Lock – L

SB-800 Flash Settings  
ON/OFF pb – OFF

## D2Xs (Continued)

### NOMINAL SETUP (Continued)



#### D2Xs CREW PHOTO

- Lens – 17-35mm @ 17mm
- Lens Focus Mode – M/A
- Aperture – Min, locked
- Body Focus Mode – S
- √Batt installed
- √Flash Card installed
- Pwr – ON
- Top LCD
  - √Batt
  - √Frames remaining sufficient
- Exp Comp (  ) – 0.0
- Exp Mode – A
- f/stop – f/8
- Meter – Matrix (  )
- Diopter – Adjust
- Frame Rate – Selftimer
- √BKT disabled – 0 F
- Rear LCD
  - √ISO – 100
  - √QUAL – RAW
  - √WB – 0,A
- AF Area Mode – [ [ ] ]
- √Focus Area – Center
- √Focus Selector Lock – L
- SB-800 Flash Settings
  - √Diffuser Dome installed
  - ON/OFF pb – ON
  - √MODE –  TTL BL
  - √Exp Comp – 0 EV
  - Tilt – 45° (Direct)
- Accessory Equipment
  - Shutter Release Cable – Install
  - Multiuse Brkt – Install
  - Multiuse Brkt, Clamp – Install as reqd

#### Technique

1. Focus on crewmember
2. Body Focus Mode – M
3. Frame, Fire

#### D2Xs EXPOSURE MATCH

- Lens – 12-24mm @ 18mm
- Lens Focus Mode – M/A
- Aperture – Min, locked
- Body Focus Mode – S
- √Batt installed
- √Flash Card installed
- Pwr – ON
- Top LCD
  - √Batt
  - √Frames remaining sufficient
- Exp Comp (  ) – 0.0
- Exp Mode – P
- Meter – Matrix (  )
- Diopter – Adjust
- Frame Rate – S
- √BKT disabled – 0 F
- Rear LCD
  - √ISO – 100
  - √QUAL – RAW
  - √WB – 0,A
- AF Area Mode – [ [ ] ]
- √Focus Area – Center
- √Focus Selector Lock – L
- SB-800 Flash Settings
  - √Diffuser Dome installed
  - ON/OFF pb – ON
  - √MODE –  TTL BL
  - √Exp Comp – 0 EV
  - Tilt – 45° (Direct)

#### Technique for Single Shots

1. Fill FOV w/sunlit subject
2. Activate D2Xs Camr
3. Auto Exp Lock – Depress, hold
- Expect values such as 250,f/11
4. Focus, Frame, Fire

#### Technique for Multiple Shots



1. Fill FOV w/sunlit subject
2. Activate D2Xs Camr
3. Note SS,f/stop
4. Expect values such as 250,f/11
5. Exp Mode – M
- SS – as noted
- Aperture – as noted

## D2Xs (Continued)

### NOMINAL SETUP (Continued)

#### D2Xs AURORA/AIRGLOW

##### Lens – 28mm

- Lens Focus Mode – A
- Aperture – Min, locked
- Body Focus Mode – S
- √Batt installed
- √Flash Card installed
- Pwr – ON
- Top LCD
  - √Batt
  - √Frames remaining sufficient
- Exp Comp (  ) – 0.0
- Exp Mode – M
- SS – 1”
- f/stop – f/1.4
- Meter – Matrix (  )
- Diopter – Adjust
- √BKT disabled – 0 F
- Rear LCD
  - √ISO – 800
  - √QUAL – RAW
  - √WB – 0,A
- AF Area Mode – [ [ ] ]
- √Focus Area – Center
- √Focus Selector Lock – L

##### SB-800 Flash Settings



ON/OFF pb – OFF

##### Technique

1. Dim cabin lights
2. Use dark clothing to shield window
3. Focus, Frame, Fire

#### D2Xs CITY LIGHTS/STARS

##### Lens – 28mm

- Lens Focus Mode – A
- Aperture – Min, locked
- Body Focus Mode – S
- √Batt installed
- √Flash Card installed
- Pwr – ON
- Top LCD
  - √Batt
  - √Frames remaining sufficient
- Exp Comp (  ) – 0.0
- Exp Mode – M
- SS – 4
- f/stop – f/1.4
- Meter – Matrix (  )
- Diopter – Adjust
- √BKT disabled – 0 F
- Rear LCD
  - ISO – 800
  - √QUAL – RAW
  - √WB – 0,A
- AF Area Mode – [ [ ] ]
- √Focus Area – Center
- √Focus Selector Lock – L

##### SB-800 Flash Settings

ON/OFF pb – OFF

##### Accessory Equipment

Shutter Release Cable – Install  
Multiuse Brkt, Clamp – Install



##### Technique

1. Dim cabin lights
2. Use dark clothing to shield window
3. Focus, Frame, Fire

## D2Xs (Continued)

### NOMINAL SETUP (Continued)

#### D2Xs LIGHTNING

Lens – 28mm  
Lens Focus Mode – A  
Aperture – Min, locked  
Body Focus Mode – S  
√Batt installed  
√Flash Card installed  
Pwr – ON  
Top LCD  
√Batt  
√Frames remaining sufficient  
Exp Comp (  ) – 0.0  
Exp Mode – M  
SS – 2"  
f/stop – f/1.4  
Meter – Matrix (  )  
Diopter – Adjust  
Frame Rate – S  
√BKT disabled – 0 F  
Rear LCD  
ISO – 400  
√QUAL – RAW  
√WB – 0,A  
AF Area Mode – [ [ ] ]  
√Focus Area – Center  
√Focus Selector Lock – L



SB-800 Flash Settings  
ON/OFF pb – OFF

Accessory Equipment  
Shutter Release Cable – Install  
Multiuse Brkt, Clamp – Install as reqd

#### Technique

1. Fire Camr repeatedly. Luck reqd

#### D2Xs MOON



Lens – as reqd  
Aperture – Min, locked  
Body Focus Mode – S  
√Batt installed  
√Flash Card installed  
Pwr – ON  
Top LCD  
√Batt  
√Frames remaining sufficient  
Exp Comp (  ) – 0.0  
Exp Mode – M  
SS – 500  
f/stop – f/8  
Meter – Matrix (  )  
Diopter – Adjust  
Frame Rate – S  
√BKT disabled – 0 F  
Rear LCD  
√ISO – 100  
√QUAL – RAW  
√WB – 0,A  
AF Area Mode – [ [ ] ]  
√Focus Area – Center  
√Focus Selector Lock – L

SB-800 Flash Settings  
ON/OFF pb – OFF

## D2Xs (Continued)

### NOMINAL SETUP (Continued)

#### D2Xs SILHOUETTE

- Lens – as reqd
- Aperture – Min, locked
- Body Focus Mode – S
- √Batt installed
- √Flash Card installed
- Pwr – ON
- Top LCD
  - √Batt
  - √Frames remaining sufficient
- Exp Comp (  ) – 0.0
- Exp Mode – P
- Meter – Matrix (  )
- Diopter – Adjust
- Frame Rate – S
- √BKT disabled – 0 F
- Rear LCD
  - √ISO – 100
  - √QUAL – RAW
  - √WB – 0,A
- AF Area Mode – [ [ ] ]
- √Focus Area – Center
- √Focus Selector Lock – L



SB-800 Flash Settings  
**ON/OFF pb – OFF**

#### Technique

1. Fill FOV w/sunlit subject
2. Activate D2XS Camr
3. **Auto Exp Lock – Depress,hold**  
Expect values such as 250,f/11
4. Focus, Frame, Fire

#### D2Xs SUNRISE/SUNSET

**WARNING**  
**DO NOT LOOK AT SUN**

- Lens – as reqd
- Aperture – Min, locked
- Body Focus Mode – S
- √Batt installed
- √Flash Card installed
- Pwr – ON
- Top LCD
  - √Batt
  - √Frames remaining sufficient
- Exp Comp (  ) – 0.0
- Exp Mode – P
- Meter – Matrix (  )
- Diopter – Adjust
- √BKT disabled – 0 F
- Rear LCD
  - √ISO – 400**
  - √QUAL – RAW
  - √WB – 0,A
- AF Area Mode – [ [ ] ]
- √Focus Area – Center
- √Focus Selector Lock – L

SB-800 Flash Settings  
**ON/OFF pb – OFF**

#### Technique

1. Focus, Frame, Fire

## D2Xs (Continued)

### NOMINAL SETUP (Concluded)

#### D2Xs SUN STAR EFFECT

Lens – 10.5mm

Aperture – Min, locked

Body Focus Mode – S

√Batt installed

√Flash Card installed

Pwr – ON

Top LCD

√Batt

√Frames remaining sufficient

Exp Comp (  ) – 0.0

Exp Mode – A

f/stop – f/22

Meter – Matrix (  )

Diopter – Adjust

Frame Rate – S

√BKT disabled – 0 F

Rear LCD

√ISO – 100

√QUAL – RAW

√WB – 0,A

AF Area Mode – [ [ ] ]

√Focus Area – Center

√Focus Selector Lock – L

SB-800 Flash Settings

ON/OFF pb – OFF

#### Technique

1. Place Sun w/Earth, orbiter, crewmember, etc. in FOV

#### D2Xs TV MONITOR

Lens – as reqd

Aperture – Min, locked

Body Focus Mode – S

√Batt installed

√Flash Card installed

Pwr – ON

Top LCD

√Batt

√Frames remaining sufficient

Exp Comp (  ) – 0.0

Exp Mode – S

SS – 30

Meter – Matrix (  )

Diopter – Adjust

Frame Rate – S

√BKT disabled – 0 F

Rear LCD

√ISO – 100

√QUAL – RAW

√WB – 0,A

AF Area Mode – [ [ ] ]

√Focus Area – Center

√Focus Selector Lock – L

SB-800 Flash Settings



ON/OFF pb – OFF

## D2Xs (Continued)





### DATE/TIME SET

1. MENU pb – press
2. Navigate pad – sel Menu icon  setup menu
  - press (right)
  - sel WORLD TIME (up,down)
  - press (right)
  - sel DATE (up,down)
  - press (right)
3. Set DATE/TIME to GMT
  - Navigate pad – sel desired field (left,right)
  - sel desired setting (up,down)
4. ENTER pb – press
5. MENU pb – press twice



### DELETING SINGLE IMAGES

1. PLAYBACK  pb – press
2. Navigate pad – sel image (up,down)
3. DELETE  pb – press twice to delete

### ADDING .WAV FILES TO AN IMAGE



1. PLAYBACK  pb – press
2. Navigate pad – sel image (up,down)
3. MICROPHONE  pb – press, hold (✓microphone icon  appears on rear LCD)
4. Talk to MIC
5. ✓Music Note icon  appears in upper left image

### DELETING .WAV FILE FROM AN IMAGE

1. PLAYBACK  pb – press
2. Navigate pad – sel image (up,down)
3. DELETE  pb – press
4. Sel – Sound only
5. DELETE  pb – press

## D2Xs (Continued)

### .WAV FILE PLAYBACK

1. PLAYBACK  pb – press
2. Navigate pad – sel image w/music note 
3. MICROPHONE  pb – press

### IMAGE FILE TRANSFER

#### DNLK FROM FLASH CARD

1. Insert Flash Card w/PCMCIA Adapter into **KFX PGSC**(any **networked PGSC**), brand name up
2. Inform MCC “files ready”

#### DCS FILE TO HARD DRIVE

1. Insert Flash Card w/PCMCIA Adapter into any **networked PGSC**, brand name up
2. Double click:
  - “My Computer” icon on desktop
  - “Removable Disk D” or appropriate drive
  - Folder “DCIM” or appropriate folder
  - Folder “100 ND2XS”
3. Select all files
4. Copy all files
5. Double click:
  - “Imagery Folder on KFX PGSC” shortcut on desktop
  - Appropriate subfolder (e.g., FD1, OMS Pod, etc.)
6. Paste files
7. Close all windows
8. Inform MCC “files ready” on PGSC
9. Stow card



## D2Xs (Continued)

### RECOVER LOST IMAGES

1. Insert suspect Flash Card into A31p, brand name up
2. Open SHUTTLE APPS | Photo Processing | mediaRECOVER
3. In 'mediaRECOVER' window
  - Sel 'Settings' in left-hand column
  - Under 'My image file size', move slider until '10.00 MB' displayed
  - Sel 'Recovery' in left-hand column
  - In 'Drive to recover' column, sel 'Removable Disk' in pulldown menu
  - Sel 'Next >'
4. In 'Where do you want to save recovered files?' column
  - Sel '...' button
  - In 'Choose directory...' window
    - Sel 'Local Disk (C)'
    - Sel 'OCA-down'
    - Sel 'Imagery'
    - Sel 'New Folder' option button
    - Type 'Recover' as new folder name
    - Press Enter
    - Click on 'Recover' folder
    - Sel 'OK'
  - Sel 'Next >'
5. In 'Progress' column
  - √'Preview' box
  - Sel 'Start'
6. In 'Analyze Drive' window

#### NOTE

Scan will take several min (~45 min)

Sel 'Use folder based recover'  
Verify '√' in box next to 'Look for additional lost files'  
Sel 'Continue'

## D2Xs (Concluded)

### RECOVER LOST IMAGES (Concluded)

7. When 'Preview' window appears, move 'Preview' window below 'mediaRECOVER' window to view progress bar

NOTE

When scan completed, 'Save Images' window will appear

8. In 'Save Images' window

NOTE

May take several minutes to save to 'Recover' folder

√All images have '√' in their select box  
Sel 'Save Images'

9. When finished saving ('Save Images' window will automatically close), close 'mediaRECOVER' window
10. Close 'Photo Processing' window
11. Notify MCC regarding location of images

D2Xs EVA CAMR

	<u>PAGE</u>
SPECIFICATIONS.....	5-2
LENS DATA.....	5-3
NOMENCLATURE.....	5-4
D2XS EVA – CAMR ONLY.....	5-5
D2XS EVA – CAMR ONLY DISASSEMBLY .....	5-9
BETWEEN EVAS.....	5-9
POST-EVA.....	5-10
D2XS EVA – CAMR W/FLASH.....	5-11
D2XS EVA – CAMR W/FLASH DISASSEMBLY .....	5-19
BETWEEN EVAs .....	5-19
POST-EVA.....	5-20
DATE/TIME SET.....	5-22
D2XS FORMAT .....	5-22
STEREO PHOTOGRAMMETRY PROCEDURE.....	5-23

**D2Xs EVA CAMR**

**SPECIFICATIONS**

CAMR BODY

CMOS SENSOR SIZE: 15.7mm x 23.7mm

PIXEL COUNT: 4288 x 2848

DISK/FRAME: 1 GB, ~90 frames; 4 GB, ~360 frames

RAW FILE SIZE: ~10 MB

EXPOSURE CONTROL: Auto (program, shutter priority, aperture priority), Manual

METER PATTERN: 3D Color Matrix, Center Weighted, Spot

EXPOSURE COMP:  $\pm 5$  in 1, 1/3, 1/2 EV steps

SHUTTER:

Program & Aperture Priority – 1/8000 thru 30 sec (virtually stepless)

Manual & Shutter Priority – 1/8000 thru 30 sec (1, 1/3, 1/2) stop increments), 250x, and Bulb (manual only)

ISO Setting: 100-3200; >800 controlled by menu

FRAME RATE: Single, C<sub>L</sub> – 3 fps, C<sub>H</sub> – 5 fps

Burst Rate: Mode dependent

CAMR BATT: Li-ION EN-EL4A

CAMR BATT VOLTAGE: 11.1VDC

CAMR BATT LIFETIME: ~1000 frames

CAMR WEIGHT: 2.4 lb (w/Batt & Memory Card)

I

## D2Xs EVA CAMR (Continued)

### LENS DATA

NOTE

Do not use non-EVA lens w/D2Xs EVA

Lens	Aperture Range (f/stop)	Approximate Field of View (FOV)			Approx Minimum Focus Distance (ft)	Weight (lb)	Filter Size	M-A Switch
		Horizontal	Vertical	Diagonal				
28mm AF	f/2.8-f/22	46°	31°	54°	1.25	0.46	52mm	
35mm AF	f/2.0-f/22	37°	25°	44°	0.9	0.51	52mm	
50mm AFD	f/1.4-f/16	27°	18°	32°	1.5	0.59	52mm	
70-200mm AF	f/2.8-f/22	19°-7°	13°-4.5°	23°-8°	6.0	2.98	77mm	Yes
85mm AF	f/1.4-f/16	16°	11°	19°	2.8	1.23	77mm	Yes
105mm AF	f/2.8-f/32	13°	9°	15°	1.0	1.22	52mm	Yes
180mm AFD	f/2.8-f/22	7°	5°	9°	5.0	1.72	72mm	Yes

# D2Xs EVA CAMR (Continued)

## NOMENCLATURE

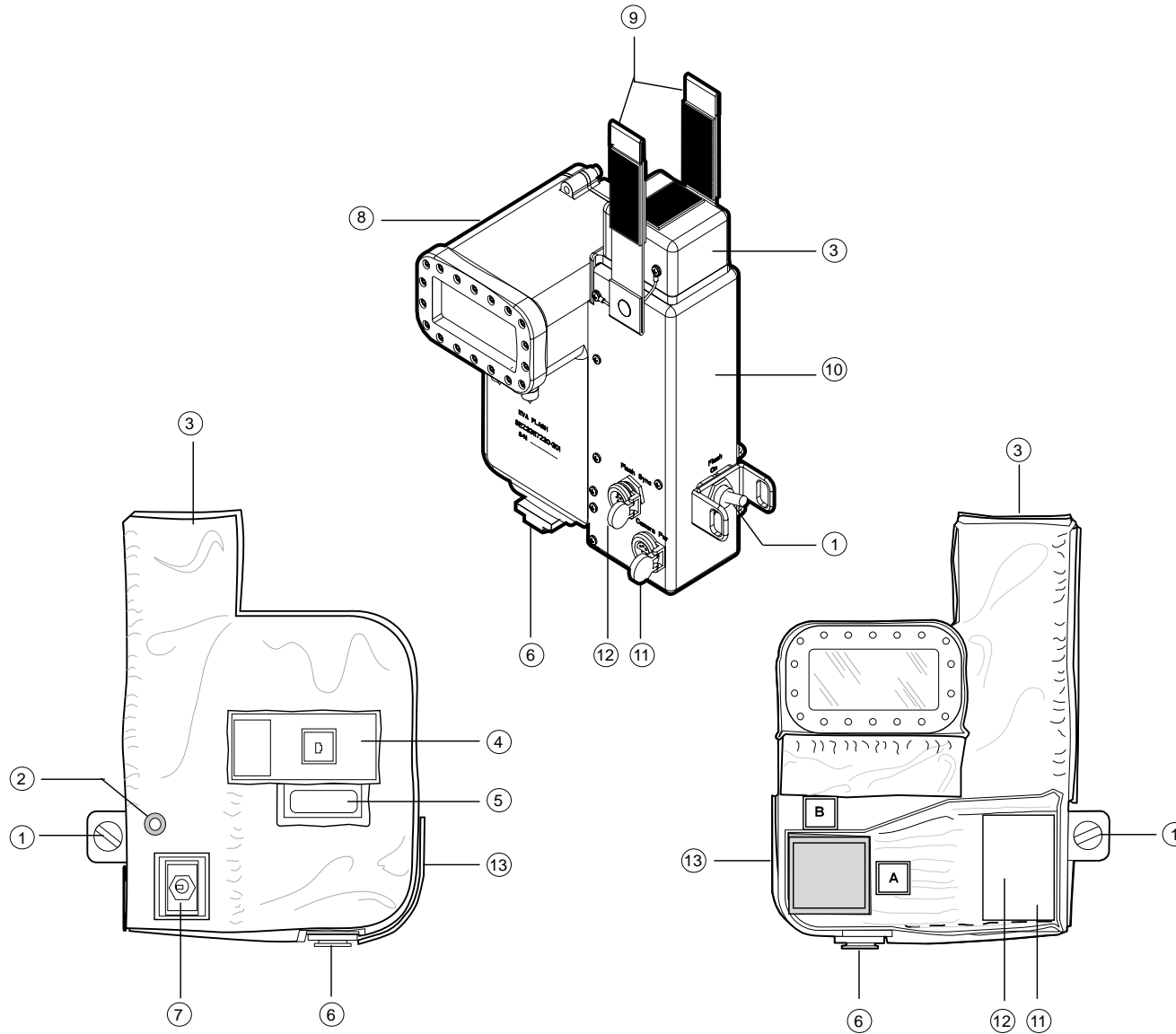

- ① Flash Pwr sw
- ② External Camr Batt Low Light/LED
- ③ Batt Cap
- ④ Rear Flash Display Window
- ⑤ Flash Ready Lt Window
- ⑥ Flash Mount Rail
- ⑦ Camr Batt Pwr sw
- ⑧ Flash Housing
- ⑨ Batt Cap Straps
- ⑩ Batt Housing
- ⑪ External Camr Pwr Port
- ⑫ Flash Sync Port
- ⑬ Flap F

jsc48037\_175r1.cvx

## D2Xs EVA CAMR (Continued)

### D2XS EVA – CAMR ONLY

#### NOTE



When Camr not in use during EVA, Thermal Lens Cap must be installed

1. Unstow,assemble  
D2Xs Camr  
Lens – as reqd  
If 28(35,50,105)mm EVA Lens:  
√Circular Polar 52mm Filter w/o glass fully installed on lens

D2Xs Batt – fully charged  
4 GB EVA Flash Card



2. Unstow but do not install  
EVA Camr Blanket  
Camr Mounting Assy w/Thermal Blanket and Tether  
EVA Eyepiece w/Thermal Wrap,Tether

D2Xs

3. Camr Settings  
Lens – as reqd  
Aperture – Min, locked  
Body Focus Mode – S  
√Batt installed  
√Flash Card installed  
Pwr – ON  
Top LCD  
√Batt  
√Frame count = 1  
If >1, perform D2Xs FORMAT, 5-22  
Exp Comp (  ) – 0.0  
Exp Mode – P  
Meter – Matrix (  )  
Diopter – Adjust  
Frame Rate – S  
√BKT disabled – 0 F

## D2Xs EVA CAMR (Continued)

### D2XS EVA – CAMR ONLY (Continued)

- D2Xs
3. Camr Settings (Concluded)
    - Rear LCD
      - √ISO – 100
      - √QUAL – RAW
      - √WB – 0,A
    - AF Area Mode – [ [ ] ]
    - √Focus Area – Center
    - √Focus Selector Lock – L
    - √Vertical Shooting Shutter Release Lock – L (L to white line) |
    - Menu Settings:
      - Menu pb – press
      - Navigate Pad sel – Playback Menu  > Image Review
        - OFF
        - Setup Menu  > Worldtime
    - √Date/Time set to GMT |
    - If reqd to set, perform DATE/TIME SET, 5-22
  4. Close Eyepiece shutter
  5. Remove IVA Eyepiece
  6. Open Eyepiece shutter
  7. Install EVA Camr Blanket starting at top of Camr
  8. √Lens Cap removed from Lens
  9. Activate Shutter Release:
    - √No “<sub>F</sub>EE” in Viewfinder
    - If “<sub>F</sub>EE” displayed:
      - Remove Lens
      - Aperture – Min, locked
      - Replace Lens
    - √Lens moves freely under EVA Camr Blanket
  10. Install 28mm, 35mm, 50mm Lens Cap (Thermal Cap)
  11. Install EVA Eyepiece



## D2Xs EVA CAMR (Continued)

### D2XS EVA – CAMR ONLY (Continued)

12. Thread Eyepiece Tether thru Hot Shoe openings on Camr Thermal Blanket  
Close Hot Shoe Cover



13. Loop Thermal Wrap thru Tether



14. Wrap Thermal Wrap around Eyepiece



## D2Xs EVA CAMR (Continued)

### D2XS EVA – CAMR ONLY (Concluded)

15. Install Camr Mounting Assy w/Thermal Blanket from rear
16. ✓Camr Mounting Assy seated, will not slip off Camr. Release pb – out
17. Connect French Hook to D-Ring on left side of Camr



FINAL CONFIGURATION

18. Stow Camr until day of EVA
- If Remote Cord Assy used:
19. Connect Remote Cord Assy to Remote Release Port on D2Xs Camr (Connector will thread into place)



20. ✓Remote Cord Assy not locked
21. Remove 28mm, 35mm, 50mm Lens Cap (Thermal Cap)
22. Test fire D2Xs w/Remote Release (two shots)
23. Install 28mm, 35mm, 50mm Lens Cap (Thermal Cap)
24. Stow until day of EVA

## D2Xs EVA CAMR (Continued)

### D2XS EVA – CAMR ONLY DISASSEMBLY

#### BETWEEN EVAs

#### NOTE

Removal of Batt, Card and Camr turnaround main objectives

D2Xs

1. Disconnect Tether from D-Ring
2. Detach Camr Mounting Assy from D2Xs Camr
3. Lift back EVA Camr Blanket to access Batt, Card compartments
4. Remove, replace:
  - D2Xs Batt
  - 4 GB EVA Flash Card
5. Re-install Camr Blanket
6. Install Camr Mounting Assy w/ Thermal Blanket from rear
7. ✓ Camr Mounting Assy seated, will not slip off Camr. Release pb – out
8. Connect French Hook to D-Ring on left side of Camr



FINAL CONFIGURATION

9. Stow Camr until day of EVA

## D2Xs EVA CAMR (Continued)

### D2XS EVA – CAMR ONLY DISASSEMBLY (Concluded)

#### POST-EVA

#### NOTE

Removal of Batt, Card and stowing of EVA H/W and IVA use of D2Xs main objectives

1. Disconnect Tether from D-Ring
2. Detach Camr Mounting Assy and Thermal Wrap from D2Xs Camr
3. Disconnect Eyepiece Tether
4. Close Eyepiece shutter
5. Remove:
  - EVA Eyepiece
  - EVA Camr Blanket
  - D2Xs Batt
  - 4 GB EVA Flash Card
6. Replace IVA Eyepiece
7. Open Eyepiece shutter

If reqd:

8. Return Camr to Nominal Ops
  - Replace D2Xs Batt and 4 GB EVA Flash Card
  - Menu Settings:
    - MENU pb – press
    - Navigate Pad sel – Playback Menu  > Image Review
      - ON
      - press twice
  - Camr Pwr – OFF

## D2Xs EVA CAMR (Continued)

### D2XS EVA – CAMR W/FLASH

#### NOTE

When Camr not in use during EVA, Thermal Lens Cap must be installed

1. Unstow, Install  
D2Xs Camr  
Lens – As Reqd  
If 28(35,50,105)mm EVA Lens:  
√Circular Polar 52mm Filter w/o glass fully installed on lens

D2Xs Batt – fully charged  
4 GB EVA Flash Card





2. Unstow but do not install  
EVA Camr Blanket  
Camr Mounting Assy w/Thermal Blanket and Tether  
EVA Eyepiece w/Thermal Wrap and Tether  
Bracket Assy w/Thermal Blanket  
EVA Flash w/Thermal Blanket  
Flash Sync Cable Assy w/Thermal Blanket  
Remote Cord Assy (SED33112525-302)

D2Xs

3. Camr Settings  
Lens – as reqd  
Aperture – Min, locked  
Body Focus Mode – S  
√Batt installed  
√Flash Card installed  
Pwr – ON

## D2Xs EVA CAMR (Continued)

### D2XS EVA – CAMR W/FLASH (Continued)

- D2Xs
3. Camr Settings (Concluded)
    - Top LCD
      - √Batt
      - √Frame count = 1
      - If >1, perform D2Xs FORMAT, 5-22
    - Exp Comp (  ) – 0.0
    - Exp Mode – P
    - Meter – Matrix (  )
    - Diopter – Adjust
    - Frame Rate – S
    - √BKT disabled – 0 F
    - Rear LCD
      - √ISO – 100
      - √QUAL – RAW
      - √WB – 0,A
    - AF Area Mode – [ [ ] ]
    - √Focus Area – Center
    - √Focus Selector Lock – L
    - √Vertical Shooting Release Lock – L (L to white line)
    - Menu Settings:
      - Menu pb – press
      - Navigate Pad sel – Playback Menu  > Image Review
        - OFF
        - Setup Menu  > Worldtime
    - √Date/Time set to GMT
    - If reqd to set, perform DATE/TIME SET, 5-22
  4. Close Eyepiece shutter
  5. Remove IVA Eyepiece
  6. Open Eyepiece shutter
  7. Install EVA Camr Blanket starting at top of Camr
  8. √Lens Cap removed from Lens
  9. Activate Shutter Release:
    - √No “<sub>F</sub>EE” in Viewfinder
    - If “<sub>F</sub>EE” displayed:
      - Remove Lens
      - Aperture – Min, locked
      - Replace Lens
    - √Lens moves freely under EVA Camr Blanket

## D2Xs EVA CAMR (Continued)

### D2Xs EVA – CAMR w/FLASH (Continued)

10. Install 28mm, 35mm, 50mm Lens Cap (Thermal Cap)
11. Install EVA Eyepiece
12. Thread Eyepiece Tether thru Hot Shoe openings on Camr Thermal Blanket



13. Loop Thermal Wrap thru Tether



14. Wrap Thermal Wrap around Eyepiece



## D2Xs EVA CAMR (Continued)

### D2Xs EVA – CAMR w/FLASH (Continued)

- Brkt Assy
15. Obtain Bracket Assy w/Thermal Blanket  
If Thermal Blanket not installed, install on Bracket Assy
  16. Insert Remote Cord Assy thru hole in Thermal Blanket (verify Remote Cord Assy not locked) and place lip of remote under Thermal Blanket

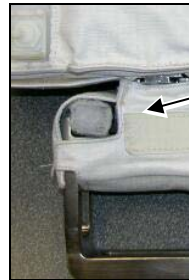

Remote Cord Lip

- D2Xs
17. Remove Flash Sync Cover from Flash Sync Cable
  18. Install Flash Sync Cable to Camr Hot Shoe:  
Lock Flash Sync Cable – turn lever cw  
Secure Camr Hot Shoe Flap to EVA Camr Blanket
  19. Reinstall Flash Sync Cover onto Flash Sync Cable Assy
  20. Install D2Xs Camr onto Bracket Assy (from front)
  21. Install EVA Flash onto Bracket Assy (from rear)

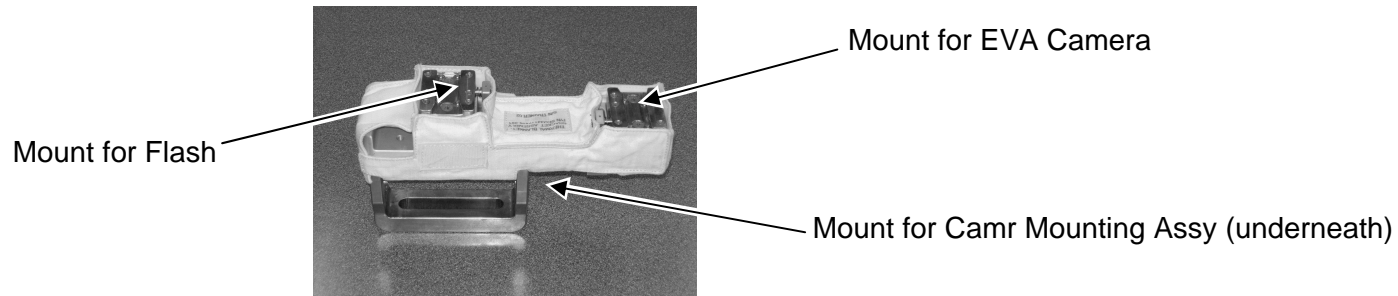



## D2Xs EVA CAMR (Continued)

### D2XS EVA – CAMR W/FLASH (Continued)

22. Install Camr Mounting Assy w/Thermal Blanket to Bracket Assy (from rear)
23. ✓D2Xs Camr, EVA Flash, and Camr Mounting Assy seated, will not slip off Bracket Assy. Release pb – out
24. Connect French Hook to D-Ring on left side of Camr

- EVA Flash
25. Open Flaps A,B,F
  26. Under Flap B, tuck excess Remote Cord Assy (three coils) into pocket on EVA Flash unit
  27. Close Flap B using two snaps



(Remote Cord Coil)

28. Connect Remote Cord Assy to Remote Release Port on D2Xs Camr (Connector will thread into place)

#### NOTE

Adjustments to cables may be reqd during installation

- D2Xs
29. Connect Flash Sync Cable Assy to Flash Sync Port on EVA Flash



Sync Port

Ext Camr Pwr Port (not used)

## D2Xs EVA CAMR (Continued)

### D2XS EVA – CAMR W/FLASH (Continued)

30. Close Flap A over Flash Sync Cable Assy, secure w/Velcro



31. Secure Flash Sync Cable and Remote Cord Assy under Flap F on right side of Flash



- EVA Flash
32. Access Flash Batt Compartment (remove Flap(s) C as reqd)
  33. Remove Batt Cap
  34. Install one DCS 760 Batt into FLASH slot (align arrows)
  35. Reinstall Batt Cap
  36. Flash – ON
  37. Activate Camr

## D2Xs EVA CAMR (Continued)

### D2XS EVA – CAMR W/FLASH (Continued)

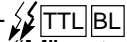
38. Open Flap D; verify following:  
√Mode –   
√Zoom – “M” not displayed  
If “M” displayed, contact MCC
- D2Xs 39. Remove 28mm, 35mm, 50mm Lens Cap (Thermal Cap)  
40. Test fire Camr w/Flash using Remote Release (two shots)  
41. √Flash fired
- EVA Flash 42. Flash – OFF  
43. Close Flap D  
44. Remove DCS 760 Batt from FLASH slot
- D2Xs 45. Install 28mm, 35mm, 50mm Lens Cap (Thermal Cap)  
46. Stow until day of EVA



### PRIOR TO ENTERING AIRLOCK:

If Camr only:

1. Remove 28mm, 35mm, 50mm Lens Cap (Thermal Cap)
2. Activate Shutter Release:  
√No “fEE” in Viewfinder  
If “fEE” displayed:  
Remove Lens  
Aperture – Min, locked  
Replace Lens
3. Test fire Camr
4. Install 28mm, 35mm, 50mm Lens Cap

## D2Xs EVA CAMR (Continued)

### D2XS EVA – CAMR W/FLASH (Concluded)

PRIOR TO ENTERING AIRLOCK; (Concluded)

- EVA Flash
- ~  
|  
If Camr w/Flash:
5. Remove Batt Cap
  6. Install DCS 760 Batt into Flash slot (align arrows)
  7. Reinstall Batt Cap
  8. Flash – ON
  9. Activate Camr
  10. Open Flap D; verify following:
    - √Mode – 
    - √Zoom – “M” not displayed
    - If “M” displayed, contact MCC
  11. Remove 28mm, 35mm, 50mm Lens Cap (Thermal Cap)
  12. Test fire Camr w/Flash
  13. Install 28mm, 35mm, 50mm Lens Cap (Thermal Cap)
  14. Flash – OFF
  15. Close Flap D
  16. Close Flap C



## D2Xs EVA CAMR (Continued)

### D2XS EVA – CAMR W/FLASH DISASSEMBLY

#### BETWEEN EVAS

#### NOTE

Removal of Batts,Cards main objective

#### FLASH

1. Flash – OFF
2. Open Flap C to access Flash Batt compartment
3. Remove Batt Cap
4. Remove DCS 760 Batt
5. Install Batt Cap
6. Close Flap C

#### CAMR

1. Disconnect Remote Cord Assy from D2Xs Camr
2. Disconnect Flash Sync Cable Assy from Camr Hot Shoe:  
Unlock Flash Sync Cable Assy – turn ccw
3. Disconnect French Hook from D-Ring
4. Detach D2Xs Camr from Bracket Assy
5. Lift back EVA Camr Blanket to access Batt,cord components
6. Remove,replace:  
D2Xs Batt  
4GB EVA Flash Card
7. Re-install Camr Blanket
8. Install D2Xs Camr onto Bracket Assy (from front)
9. √D2Xs Camr, EVA Flash, and Camr Mounting Assy seated, will not slip off Bracket Assy. Release pb – out
10. Connect French Hook to D-Ring on left side of Camr
11. Connect Remote Cord Assy to Remote Release Port on D2Xs Camr (Connector will thread into place)

#### NOTE

Adjustments to cables may be reqd during installation

#### D2Xs

12. Connect Flash Sync Cable Assy to Camr Hot Shoe
13. Lock Flash Sync Cable – turn lever cw
14. Re-install Flash Sync Cover onto Flash Sync Cable Assy
15. Stow until day of EVA

## D2Xs EVA CAMR (Continued)

### D2XS EVA – CAMR W/FLASH DISASSEMBLY (Continued)

#### POST-EVA

##### NOTE

Stowing of EVA H/W and IVA use of D2Xs main objective

#### CAMR W/FLASH

1. Disconnect Remote Cord Assy from D2Xs Camr
2. Disconnect Flash Sync Cable Assy from Camr Hot Shoe:  
Unlock Flash Sync Cable Assy – turn ccw
3. Disconnect French Hook from D-Ring
4. Detach Camr Mount,D2Xs Camr from Bracket Assy

#### CAMR

##### NOTE

Eyepiece shutter must be closed in order to remove Eyepiece

1. Disconnect Eyepiece Tether from Camr
2. Close Eyepiece Shutter
3. Remove:  
EVA Eyepiece  
EVA Camr Blanket  
D2Xs Batt  
4 GB EVA Flash Card
4. Replace IVA Eyepiece
5. Open Eyepiece shutter

## D2Xs EVA CAMR (Continued)

### D2XS EVA – CAMR W/FLASH DISASSEMBLY (Concluded)

#### POST-EVA (Concluded)

#### EVA FLASH AND FLASH BRACKET

1. Flash – OFF
2. Open Flap C to access Flash Batt compartment
3. Open Batt Cap and remove DCS 760 Batt
4. Secure Batt Cap
5. Close Flap C
6. Open Flaps A,B,F
7. Disconnect Flash Sync Cable Assy from Flash
8. Remove Remote Cord Assy, Flash Sync Cable from Flap B
9. Close Flaps A,B,F
10. Remove EVA Flash from Bracket Assy
11. Remove Remote Cord Assy from Thermal Blanket
12. Stow all EVA H/W as reqd

#### RETURN CAMR TO NOM OPS (AS REQD)

1. Replace D2Xs Batt and 4 GB EVA Flash Card
2. Camr Settings:
  - Camr Pwr sw – ON
  - Menu Settings:
    - MENU pb – press
    - Navigate Pad sel – Playback Menu  > Image Review
    - ON
    - MENU pb – press twice
    - Nom Ops settings
3. Camr Pwr – OFF

## D2Xs EVA CAMR (Continued)

### DATE/TIME SET

1. MENU pb – press
2. Navigate pad – sel Menu icon **Y**
  - press (right)
  - sel WORLD TIME (up,down)
  - press (right)
  - sel DATE (up,down)
  - press (right)
3. Set TIME/DATE to GMT
  - Navigate pad – sel desired field (left,right)
  - sel desired setting (up,down)
4. ENTER pb – press
5. MENU pb – press twice

### D2XS FORMAT

1. Pwr – ON
2. MENU pb – press
3. Navigate pad –set up MENU **Y**
  - sel 'Format'
  - sel 'Yes'
4. ENTER pb – press
5. 'Formatting'
6. 'Done'
7. MENU pb – press twice



## D2Xs EVA CAMR (Concluded)

### STEREO PHOTOGRAMMETRY PROCEDURE

#### CAMR SETTINGS – ACTIVATION

1. Rcd CAMR and LENS S/Ns
2. Perform EVA – CAMR ONLY (CAMR w/BRACKET ONLY, CAMR w/FLASH)
3. Install Lens – 35mm(28mm) EVA  
Exp Mode – P  
Flash Settings:  
ON/OFF – OFF

#### TECHNIQUE

1. Distance to subject: 5-7 ft
2. Take mapping images normal to surface, followed by one additional convergent view on each side
3. Shoot photos in pairs. Offset each image laterally 2 in/ft of subject distance, ~10-14 in
4. An additional row of photos may be taken at a 90-60 deg angle to surface to capture critical details not covered in previous images
5. Repeat as time permits

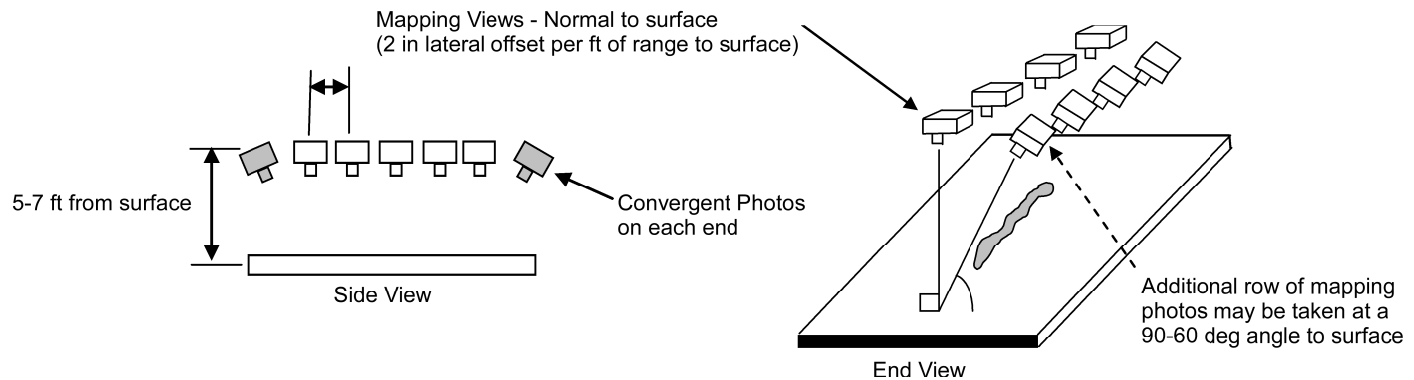

This Page Intentionally Blank

## EVA IR CAMR

	<u>PAGE</u>
SPECIFICATIONS.....	6-3
NOMENCLATURE.....	6-4
CAMR SETUP.....	6-8
IR CAMR BRACKET ASSEMBLY.....	6-8
NOMINAL MENU SETTINGS.....	6-9
MOVIE RECORDING.....	6-10
MOVIE PLAYBACK.....	6-10
DOWNLINKING FILES.....	6-10
DELETING FILES.....	6-10
DELETE SINGLE FILES ON CF CARD.....	6-10
DELETE ALL FILES ON CF CARD.....	6-10
LEVEL/SPAN MODES.....	6-11
MANUAL ADJUST MODE.....	6-11
CONTINUOUS ADJUST MODE.....	6-11
DATE/TIME SET.....	6-11
SELECTING DIFFERENT PALETTES.....	6-11
RESET TO NASA PROFILE.....	6-11
DEACTIVATION.....	6-11
MALS.....	6-12
6.1 NO LCD PWR/DISPLAY.....	6-12
6.2 RCU pbs NOT RESPONDING.....	6-13
6.3 BATT LED NOT SOLID GREEN.....	6-14
6.4 IR CAMR WILL NOT RECORD.....	6-15
6.5 WHITE LCD WITH "HOT" TEXT.....	6-16
6.6 MOVIE TRANSFER ERROR.....	6-17

This Page Intentionally Blank

## EVA IR CAMR

### SPECIFICATIONS

#### CAMR

PIXEL COUNT: 320 x 240

SPECTRAL RANGE: 7.5 $\mu$ m-13 $\mu$ m (Far IR)

INTERNAL RAM MEMORY: 600 images

CF CARD/FRAME: 1 GB/6000 images

FILE SIZE: ~167 KB per image

TEMPERATURE SENSING RANGE: -40°F to +250°F(-40°C to +120°C)

LEVEL/SPAN: Auto(Manual)

EMISSIVITY RANGE: 0.01 to 1.0

BATT: EHIP

BATT VOLTAGE: 6V

LENS FOV: 24°x18°

POINTING LASER: Wavelength = 635nm

# EVA IR CAMR (Continued)

## NOMENCLATURE

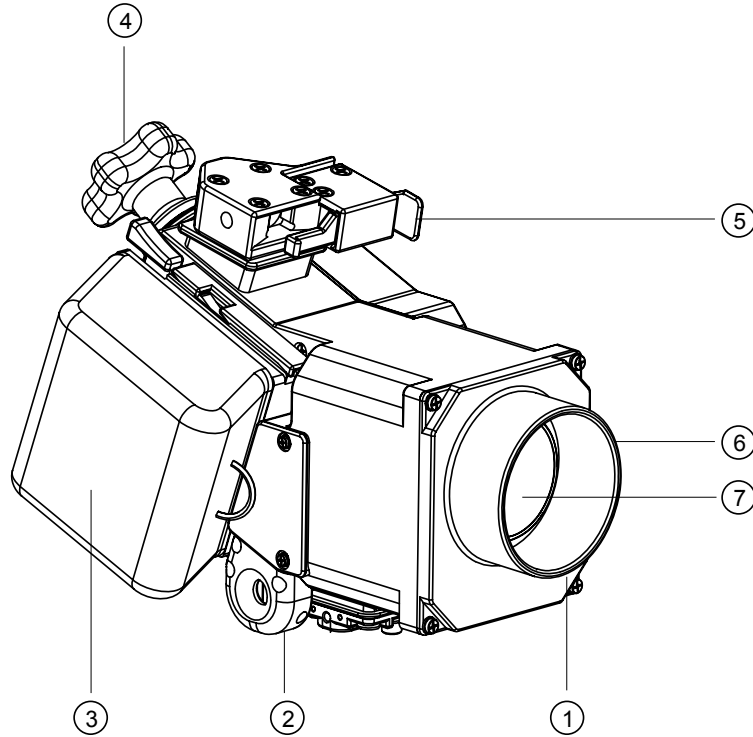

- ① Pointing Laser - Lower side of Baffle (not shown)
- ② RCU Cable Strain Relief
- ③ EHIP Batt
- ④ EVA Knob (provides handhold for pointing)
- ⑤ STD Slide-Lock (holds remote during translation)
- ⑥ Lens Baffle

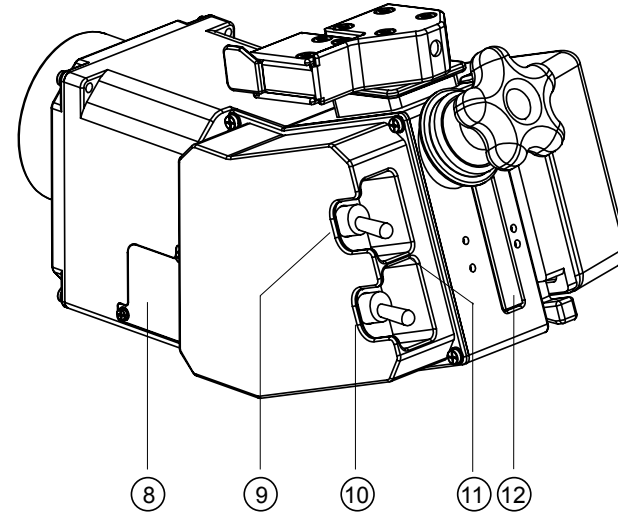

- ⑦ Lens
- ⑧ Access Cover
- ⑨ ENABLE sw
- ⑩ MASTER sw
- ⑪ Batt Status Indicator LED
- ⑫ Compact Flash Memory Card Access (Card secured w/latch (not shown))

jsc48037\_121\_076.cvx

# EVA IR CAMR (Continued)

## NOMENCLATURE (Continued)

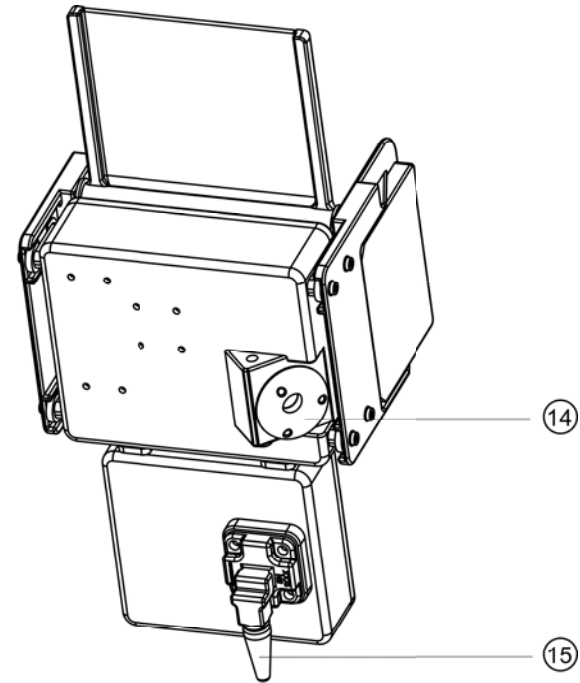
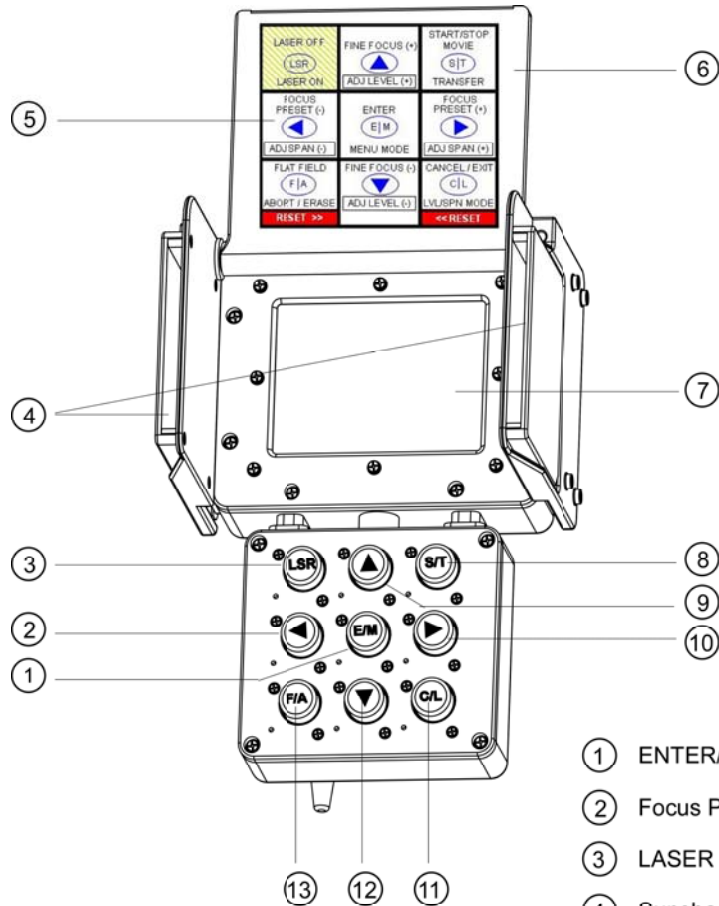









- ① ENTER/MENU MODE (E/M) pb
- ② Focus Preset (-) / Adj Span (-) pb
- ③ LASER (LSR) pb
- ④ Sunshades
- ⑤ Pb Map/Cheat Sheet
- ⑥ LCD Cover
- ⑦ LCD
- ⑧ START,STOP/TRANSFER (S/T) pb
- ⑨ Fine Focus (+) / Adj Level (+) pb
- ⑩ Focus Preset (+) / Adj Span (+) pb
- ⑪ CANCEL/LEVEL (C/L) pb
- ⑫ Fine Focus (-) / Adj Level (-) pb
- ⑬ FLAT FIELD/ABORT,ERASE (F/A) pb
- ⑭ Cable Attach Point
- ⑮ Bayonet

jsc48037\_121\_077.cvx

## EVA IR CAMR (Continued)

### NOMENCLATURE (Continued)

LASER OFF  LASER ON	FINE FOCUS (+)  ADJ LEVEL (+)	START/STOP MOVIE  TRANSFER
FOCUS PRESET (-)  ADJ SPAN (-)	ENTER  MENU MODE	FOCUS PRESET (+)  ADJ SPAN (+)
FLAT FIELD  ABORT / ERASE	FINE FOCUS (-)  ADJ LEVEL (-)	CANCEL / EXIT  LVL/SPN MODE
<b>RESET &gt;&gt;</b>		<b>&lt;&lt; RESET</b>

#### LSR pb

- Push to turn laser OFF
- Push,hold ~3 sec to activate laser

#### Up/Down Arrow pbs

- Push,hold to fine focus
- When in "Level/Span:Manual", push,hold to increase(decrease) level
- When in Menu Mode, use to navigate and change parameters

#### S/T pb

- Push to start(stop) movie recording
- Push,hold ~3 sec to transfer images from RAM to compact flash card

#### Left/Right Arrow pbs

- Push to select preset focus distances (3,6,9,12 ft, or infinity)
- When in "Level/Span:Manual", push,hold to adjust span
- When in Menu Mode, use to navigate and change parameters

#### E/M pb

- Push to enter functions or change parameters
- Push,hold ~3 sec to enter Menu Mode

#### F/A pb

- Push to perform flat field correction
- When transferring a movie, push,hold ~3 sec to abort transfer
- When not transferring a movie, push,hold ~3 sec to erase imagery in RAM

#### C/L pb

- Push to cancel(exit) various menu/Camr options
- After selecting "Manual Adjust" in menu, push,hold ~3 sec to toggle the functionality of Up/Down/Left/Right arrow pbs between focus and level/span modes

#### F/A and C/L pbs simo

- Push,hold simo ~3 sec to reset menu settings back to default parameters



## EVA IR CAMR (Continued)

### NOMENCLATURE (Concluded)

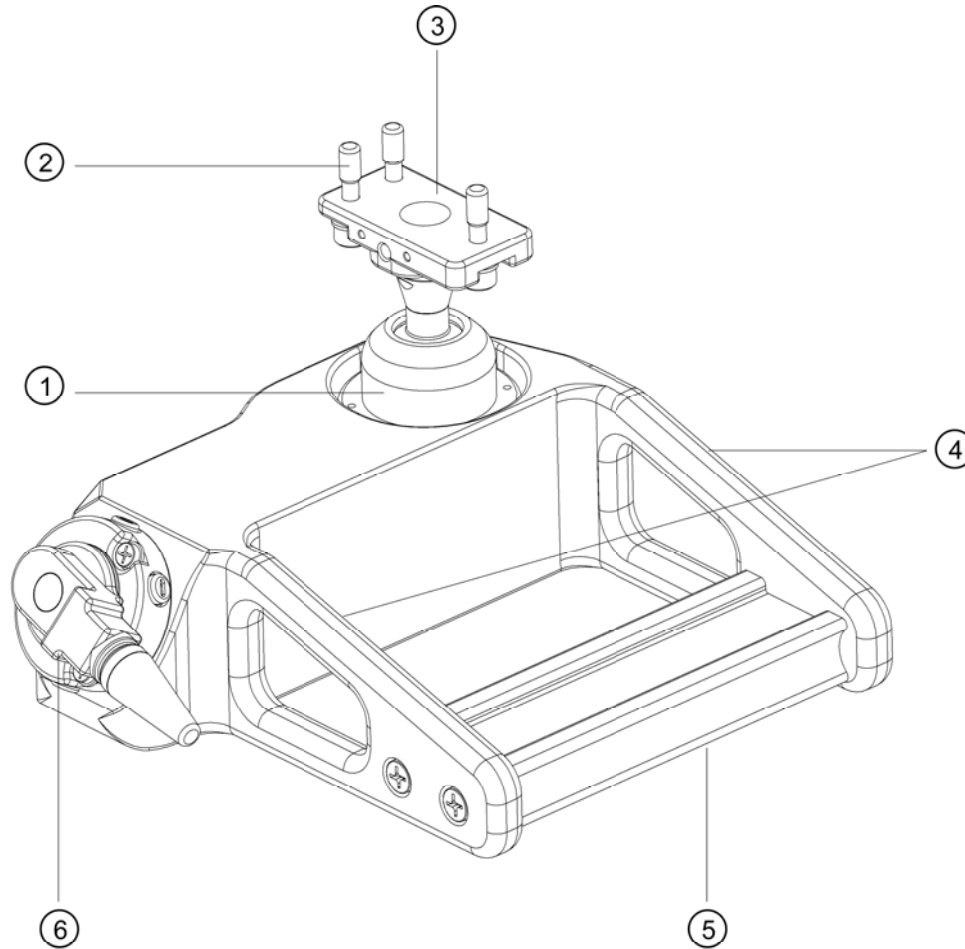

- ① Ball Joint
- ② Bracket Screws
- ③ Camr Interface
- ④ Tether Loop (two)
- ⑤ Dogbone Handrail
- ⑥ Clockable Bayonet

jsc48037\_121\_078.cvx

## EVA IR CAMR (Continued)

### CAMR SETUP

1. If Camr Bracket not installed, perform IR CAMR BRACKET ASSEMBLY procedure
2. Install EHIP Batt
3. ✓CF card installed
4. Lens Cover – Fold to left side
5. MASTER sw – ON (wait 20 sec for initialization)
6. ✓Manual('Level/Span: Manual') not displayed in top left of LCD
7. ✓Date/Time – GMT
8. E/M pb – push,hold
  - Sel: "File – Burst Setup"
  - Max # frames – 300
  - Save every – 12th frame
  - ✓FPS – 5.0
  - ✓Elapse Time – 60
  - E/M pb – push
9. E/M pb – push,hold
  - Sel: "File – Images..."
  - If images present in directory:
    - E/M pb – push,hold
    - Sel: "Delete all images"
    - Sel: "Delete"
  - ✓NO images present in directory
  - C/L pb – push
10. ENABLE sw – OFF (hold for 3 sec, observe shutdown msg on screen)
11. Lens cover – Reinstall
12. If not using within 3 hr:
  - MASTER sw – OFF

### IR CAMR BRACKET ASSEMBLY

1. Tools Req'd (IFM Tool Locker Tray 3)
  - 1/4-in Torque Wrench (40-200 in-lb)
  - 5/32-in Hex Ball
2. Align Camr Body to Camr Bracket
3. Tighten bracket screws to Camr Body, snug (three screws, 5/32-in Hex Ball)
4. Torque bracket screws to 49 in-lb

## EVA IR CAMR (Continued)

### NOMINAL MENU SETTINGS

#### FILE ('File')

Images... – N/A  
Save – N/A  
Burst Setup  
    Max # Frames – 300  
    Save every – 12th frame  
    FPS – 5.0  
    Elapse Time – 60  
Burst recording... – N/A

#### ANALYSIS ('Analysis')

Object Param...  
    Emissivity – 0.96  
    Distance – 6.6 ft  
    T Reflected – 68°F  
    T Atmosphere – 68°F  
    Rel Humidity – 30%  
    External optics – Off  
    Optics transmission – N/A  
    Optics temperature – N/A

#### IMAGE ('Image')

Level/Span... – N/A  
Manual Adjust – displayed  
Palette...  
    Palette – Gray  
    Inverted – No

#### SETUP ('Setup')

Image...  
    Adjust method – Histogram  
    Lock scale – Off  
    Lock value – blank  
    Scale – On  
    Status bar – On  
    Saturation colours – Off  
    Noise reduction – Off  
    Shutter period – Normal  
Other Settings  
    Power...  
        Auto power off – None  
        Display power off – None  
        LCD illumination – Medium  
    Date/Time... – set per GMT  
Local Settings...  
    Temp unit – °F  
    Distance unit – Feet  
    Date format – MM/DD/YY  
Camera info... – N/A  
Profile – N/A  
Factory default – N/A

## EVA IR CAMR (Continued)

### MOVIE RECORDING

1. √MASTER sw – ON
2. Lens Cover – remove
3. ENABLE sw – ON
4. Wait 5 min before recording images
5. Focus on subject
6. F/A pb – push
7. S/T pb – press (start recording)
8. S/T pb – press (stop recording)
9. S/T pb – press and hold (transfer)
10. √Transfer complete

### MOVIE PLAYBACK

1. E/M pb – push,hold
2. Sel: “File – Images...”
3. E/M pb – push
4. Sel desired file
5. E/M pb – push
6. Sel: 
7. E/M pb – push
8. When finished: C/L pb – push

### DOWNLINKING FILES

- |          |   |
|----------|---|
| IR Camr  | 1. Remove compact flash (CF) card from Camr     |
|          | 2. Assemble CF Card and PCMCIA Adapter          |
| KFX PGSC | 3. Place assembled card,adapter in PGSC         |
|          | 4. Copy files to “C:\Oca-down\dto851”           |
|          | 5. Remove assembled card,adapter from PGSC      |
|          | 6. Disassemble and place CF Card back into Camr |

### DELETING FILES

#### DELETE SINGLE FILES ON CF CARD

1. E/M pb – push,hold
2. Sel: “File – Images...”
3. E/M pb – push
4. Sel desired file
5. E/M pb – push,hold
6. Sel: “Delete”
7. E/M pb – push
8. Sel: “Delete”
9. E/M pb – push

#### DELETE ALL FILES ON CF CARD

1. E/M pb – push,hold
2. Sel: “File – Images...”
3. E/M pb – push
4. E/M pb – push,hold
5. Sel: “Delete all images”
6. E/M pb – push
7. Sel: “Delete”
8. E/M pb – push
9. C/L pb – push

## EVA IR CAMR (Concluded)

### LEVEL/SPAN MODES

#### MANUAL ADJUST MODE

##### NOTE

In this mode, user adjusts level,span

1. E/M pb – push,hold
2. Sel: “Image – Manual adjust”
3. E/M pb – push

##### NOTE

C/L pb will change functionality of arrow pb.

If “Level/Span: Manual” displayed in top left of LCD:  
Up/Down arrow pbs adjust level  
Left/Right pbs adjust span.

If “Manual” displayed in top left of LCD:  
Up/Down arrow pbs adjust fine focus  
Left/Right pbs adjust focus preset

#### CONTINUOUS ADJUST MODE

##### NOTE

In this mode, Camr automatically adjusts level,span

1. E/M pb – push,hold
2. Sel: “Image – Continuous adjust”
3. E/M pb – push

### DATE/TIME SET

1. E/M pb – push,hold
2. Sel: “Setup – Other settings”
3. E/M pb – push
4. Sel: “Date/time”
5. E/M pb – push
6. Sel desired field (up/down arrow pb)
7. Sel desired setting (left/right arrow pb)
8. E/M pb – push

### SELECTING DIFFERENT PALETTES

1. E/M pb – push,hold
2. Sel: “Image – Palette...”
3. E/M pb – push
4. Sel desired palette (left/right arrow pb)
5. E/M pb – push

### RESET TO NASA PROFILE

1. √All images transferred to CF card
2. F/A pb,C/L pb – push and hold simo for 3 sec

### DEACTIVATION

1. √All images transferred to CF card
2. ENABLE sw – OFF (hold for 3 sec)
3. MASTER sw – OFF
4. Lens Cover – cl

# IR CAMR

## 6.1 NO LCD PWR/DISPLAY

No LCD  
Pwr/Display

**Nominal Config:**  
(Camr)  
EHIP – install  
CF Card – install  
Lens Cover – fold to left  
MASTER sw – ON  
√“Level/Span: Manual” or “Manual” not display on LCD  
  
(RCU Menu – Burst Setup)  
√Max # frames: 300  
√Save every: 12 frame

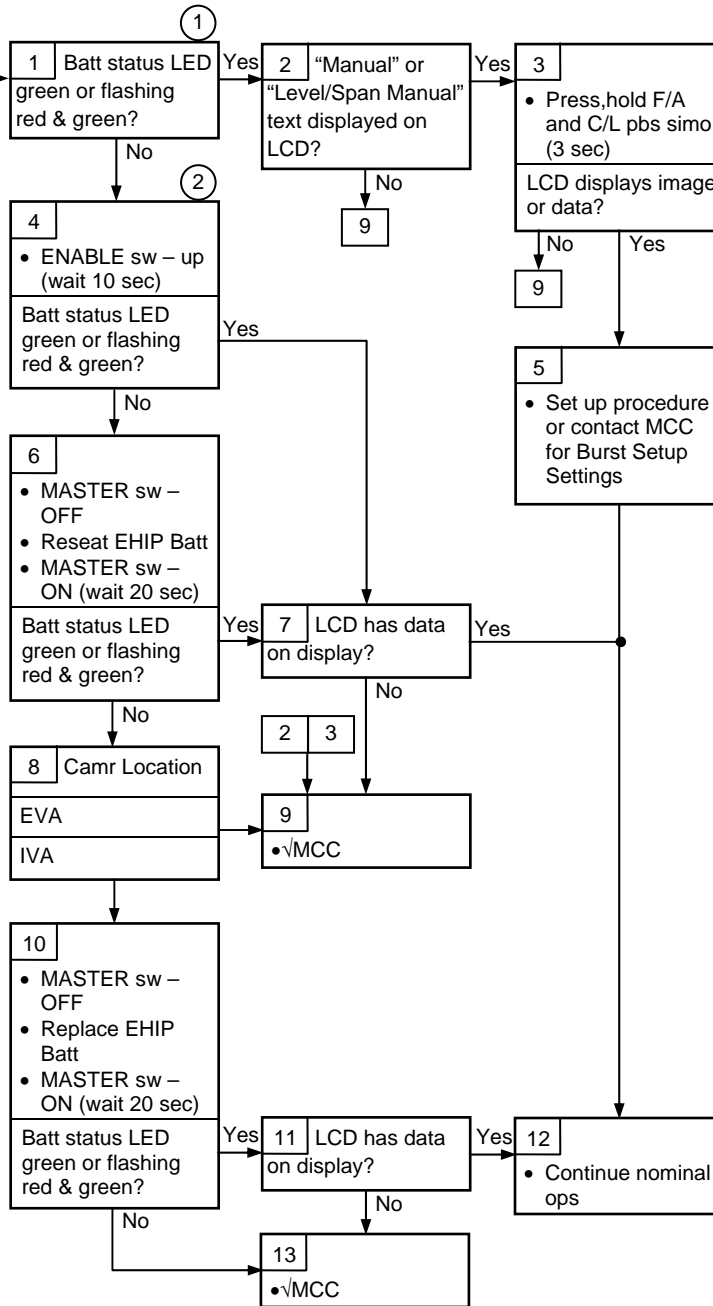

①  
Flashing red & green LED indicates that 75% of Batt has been used

②  
ENABLE sw is a momentary sw

# IR CAMR

## 6.2 RCU pbs NOT RESPONDING

RCU pbs Not Responding

**Nominal Config:**  
(Camr)  
EHIP – install  
CF Card – install  
Lens Cover – fold to left  
MASTER sw – ON  
√“Level/Scan: Manual” or “Manual” not display on LCD  
  
(RCU Menu – Burst Setup)  
√Max # frames: 300  
√Save every: 12 frame

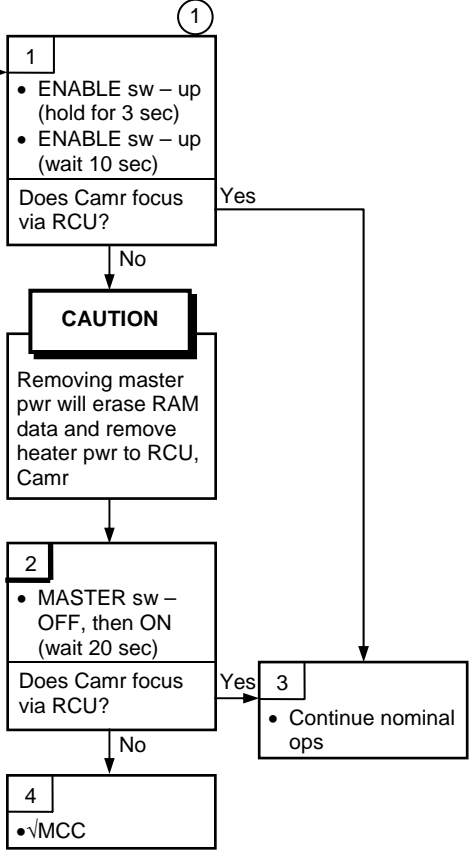

①  
ENABLE sw is a momentary sw

# IR CAMR

## 6.3 BATT LED NOT SOLID GREEN

I

Batt LED Not Solid Green

**Nominal Config:**  
 (Camr)  
 EHIP – install  
 CF Card – install  
 Lens Cover – fold to left  
 MASTER sw – ON  
 √“Level/Span: Manual” or “Manual” not display on LCD  
 (RCU Menu – Burst Setup)  
 √Max # frames: 300  
 √Save every: 12 frame

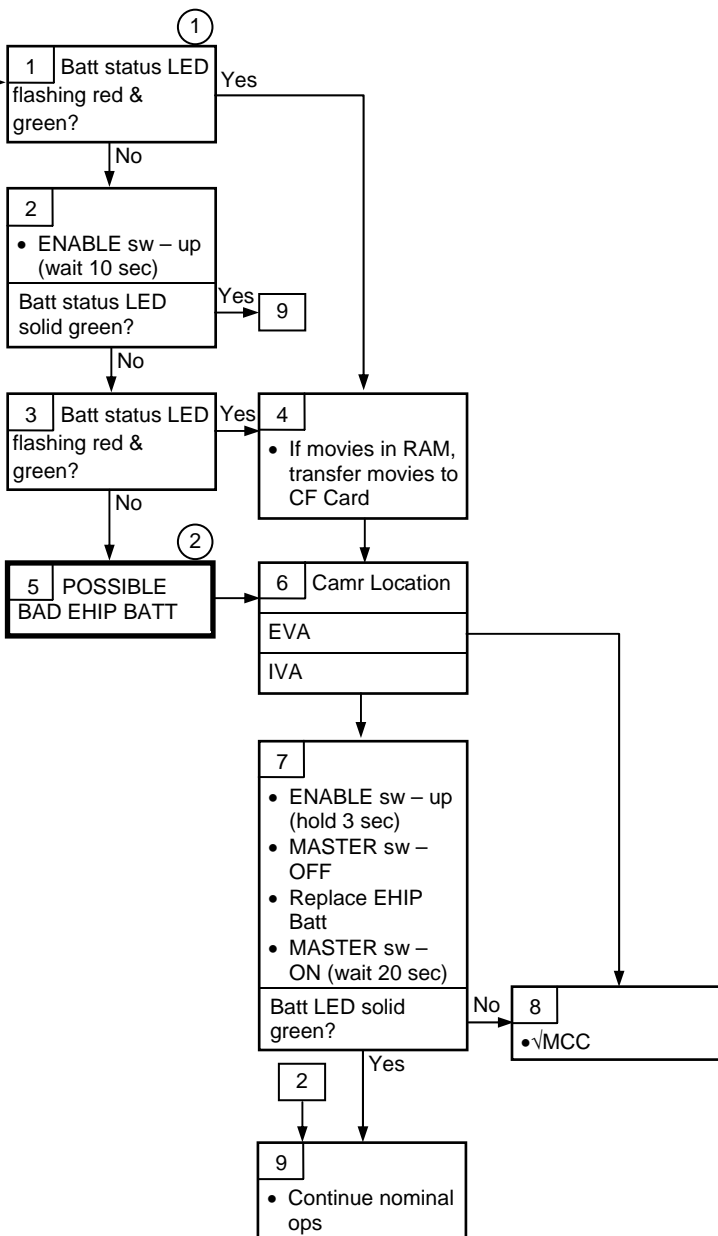

- ① Flashing red & green LED indicates that 75% of Batt has been used
- ② ENABLE sw is a momentary sw



# IR CAMR

## 6.4 IR CAMR WILL NOT RECORD

IR Camr Will Not Record

**Nominal Config:**  
 (Camr)  
 EHIP – install  
 CF Card – install  
 Lens Cover – fold to left  
 MASTER sw – ON  
 √“Level/Span: Manual” or “Manual” not display on LCD

(RCU Menu – Burst Setup)  
 √Max # frames: 300  
 √Save every: 12 frame

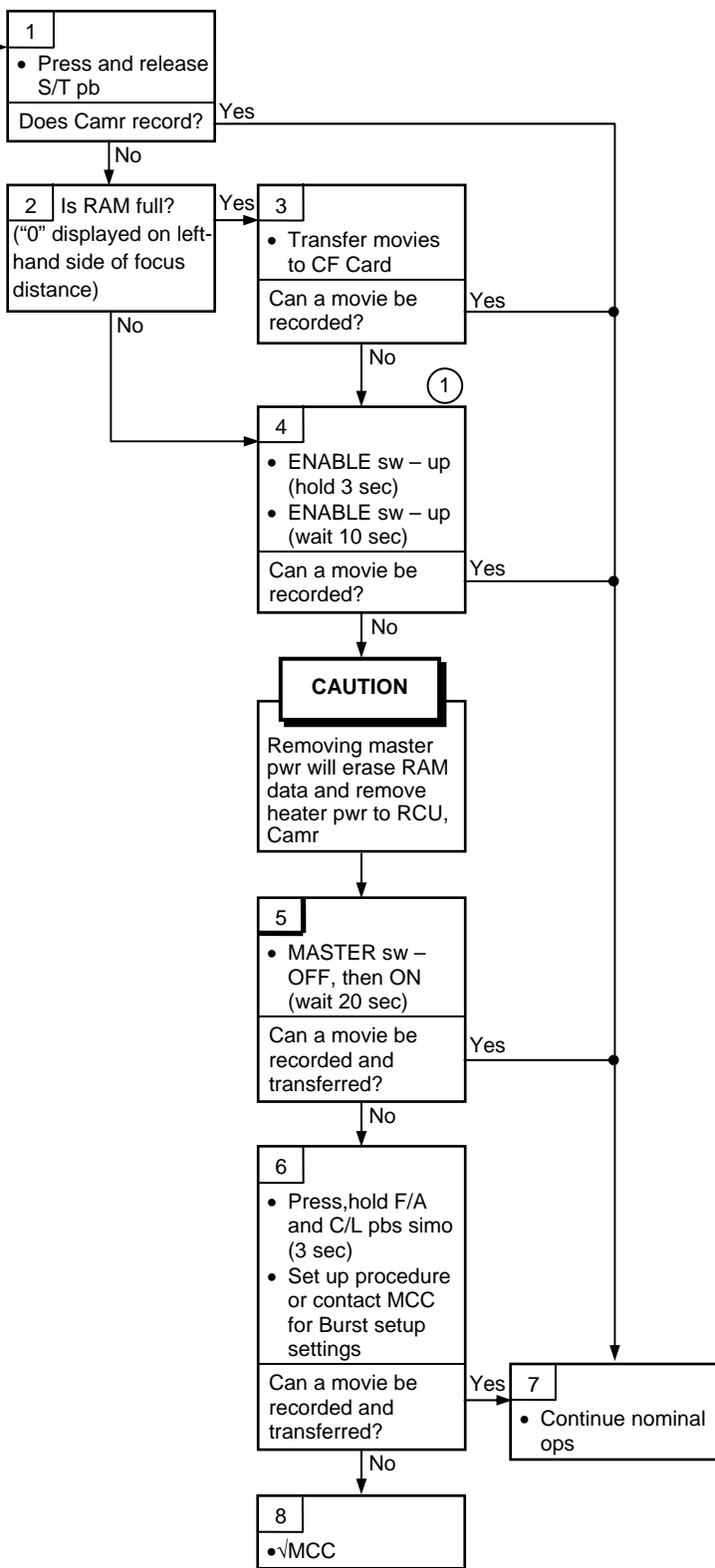

①  
 ENABLE sw is a momentary sw

**IR CAMR**

**6.5 WHITE LCD WITH "HOT" TEXT**

I

White LCD With  
"Hot" Text

**Nominal Config:**  
(Camr)  
EHIP – install  
CF Card – install  
Lens Cover – fold  
to left  
MASTER sw – ON  
√"Level/Span:  
Manual" or  
"Manual" not  
display on LCD  
  
(RCU Menu – Burst  
Setup)  
√Max # frames: 300  
√Save every: 12  
frame

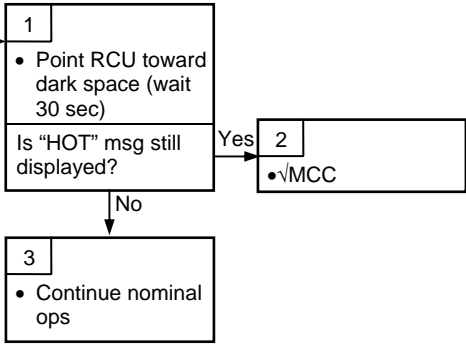

# IR CAMR

## 6.6 MOVIE TRANSFER ERROR

Movie Transfer Error

**Nominal Config:**  
(Camr)  
EHIP – install  
CF Card – install  
Lens Cover – fold to left  
MASTER sw – ON  
√“Level/Span: Manual” or “Manual” not display on LCD

(RCU Menu – Burst Setup)  
√Max # frames: 300  
√Save every: 12 frame

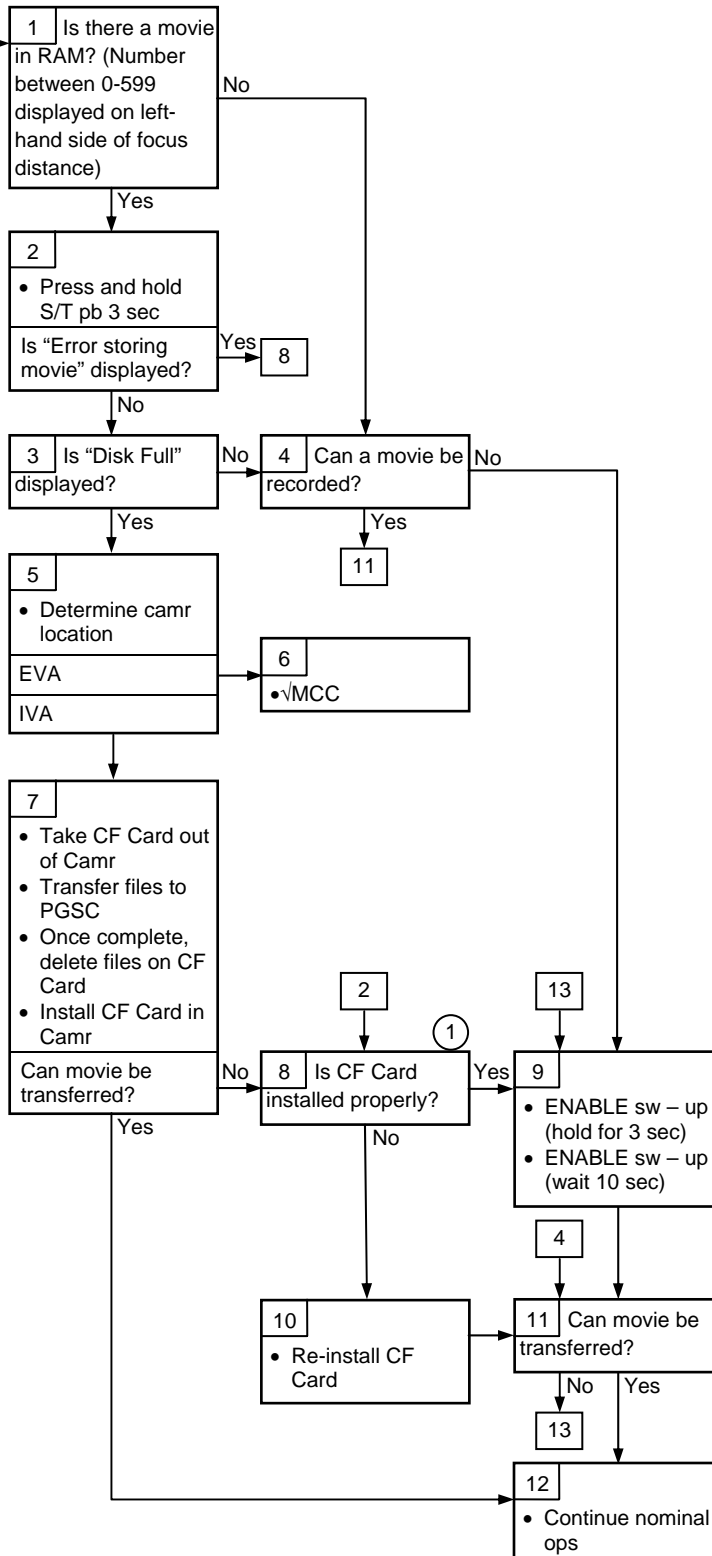

①  
If CF Card not properly installed, Burst record settings are not configurable via menu

IR CAMR 6.6 (Cont)

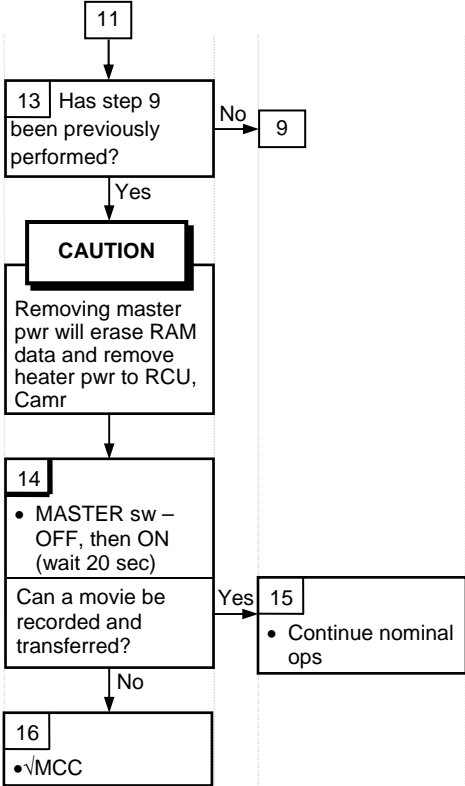

CANON G1

	<u>PAGE</u>
SPECIFICATIONS.....	7-2
LENS DATA.....	7-2
NOMENCLATURE.....	7-3
NOMINAL MENU SETTINGS.....	7-10
MANUAL SETTINGS.....	7-14
ANALOG (SD DTV) CC REC,DNLK.....	7-15
HD DIGITAL CC DNLK.....	7-17
CC BATT CHARGING.....	7-19
G1 TO G1 VIA FIREWIRE.....	7-20
G1 TO V10 VIA FIREWIRE.....	7-21
G1 TO V10 VIA ORBITER TV SYSTEM.....	7-22
G1 TO DSR-25 VTR.....	7-23
SINGLE CAMCORDER W/CAMCORDER MICROPHONE.....	7-24

# CANON G1

## CANON G1

### SPECIFICATIONS

IMAGE SENSOR: 1/3-in CCD x 3 (1,670,000 pixels)  
ZOOM: 20X Optical Zoom, 4.5-90mm (32.5-650mm, 35mm in Photo Equivalent)  
VIDEO RECORDING SYSTEM:  
    HDV – High Definition Video 1080i  
    DV – Standard Definition Video 480i  
AUDIO RECORDING SYSTEM:  
    HDV – MPEG-1, 16 bit (48kHz)  
    DV – PCM Digital Sound, 16 bit (48kHz) or 12 bit (32kHz)  
TAPE FORMAT: Mini DV Cassette (Mini DVCAM acceptable)  
MAXIMUM RECORDING TIME:  
    HDV – 60 min  
    DV: SP – 60 min; LP – 90 min  
VIEWFINDER: 0.57-in wide, 16:9 aspect ratio TFT Color; ~269,000 pixels  
LCD SCREEN: 2.8-in wide, 16:9 aspect ratio TFT Color; ~207,000 pixels  
MICROPHONE: Stereo Electret, Cross-layout  
FOCUS SYSTEM: Autofocus, Manual Focusing w/Focus Ring  
WHITE BALANCE: Auto White Balance, Preset, Custom, Manual  
MINIMUM ILLUMINATION: 0.4 lx (1/3 Shutter, F1.6, Gain 18 dB)  
IMAGE STABILIZATION: Optical Shift Image Stabilizer  
POWER: 7.2V Li-ION Batt Pack, 8.4V DC In  
BODY WEIGHT: 4.6 lb  
BATT LIFETIME: ~90 min  
BATT WEIGHT: 0.41 lb  
WIDE ANGLE CONVERTER:  
    CONVERSION – 0.8X  
    CONVERTED FOCAL LENGTH – 3.6-72mm  
    WEIGHT – 1.60 lb

### LENS DATA

Lens	Zoom Ratio	Approximate Field of View			Filter Size
		Horizontal	Vertical	Diagonal	
4.5-90mm	20:1	58°-3.2°	40.5°-2.1°	67.3°-3.8°	72mm
w/Wide Conversion Lens 3.6-72mm	20:1	69.4°-4.0°	49.5°-2.6°	79.6°-4.8°	N/A

# CANON G1 (Continued)

## NOMENCLATURE

### CAMCORDER – TOP VIEW

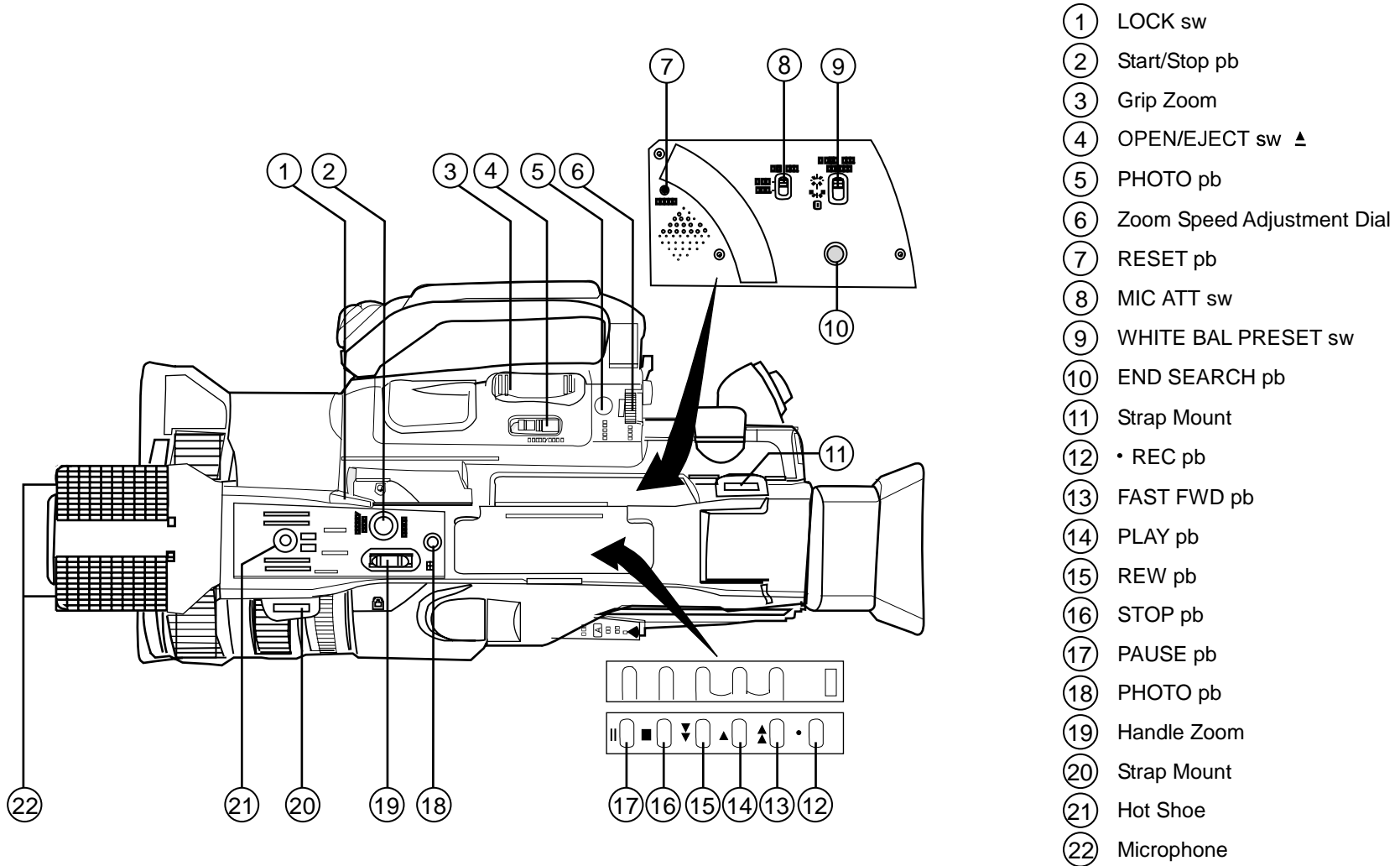

- ① LOCK sw
- ② Start/Stop pb
- ③ Grip Zoom
- ④ OPEN/EJECT sw ▲
- ⑤ PHOTO pb
- ⑥ Zoom Speed Adjustment Dial
- ⑦ RESET pb
- ⑧ MIC ATT sw
- ⑨ WHITE BAL PRESET sw
- ⑩ END SEARCH pb
- ⑪ Strap Mount
- ⑫ • REC pb
- ⑬ FAST FWD pb
- ⑭ PLAY pb
- ⑮ REW pb
- ⑯ STOP pb
- ⑰ PAUSE pb
- ⑱ PHOTO pb
- ⑲ Handle Zoom
- ⑳ Strap Mount
- ㉑ Hot Shoe
- ㉒ Microphone

jsc48037\_161.cvx

# CANON G1 (Continued)

## NOMENCLATURE (Continued)

### CAMCORDER – LEFT SIDE FRONT SECTION

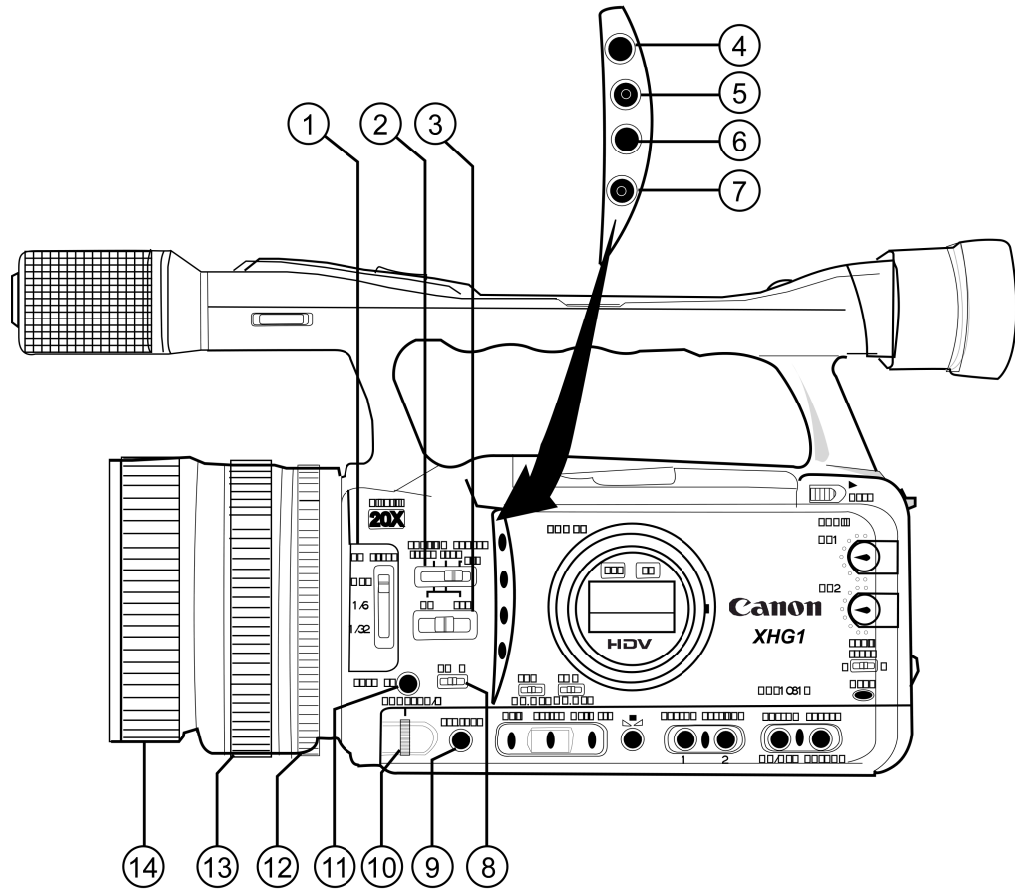

- ① ND FILTER sw
- ② POSITION PRESET sw
- ③ POSITION PRESET ON/SET sw
- ④ DISP. (Display) pb
- ⑤ PEAKING pb
- ⑥ MAGN. (Magnification) pb
- ⑦  (Record Review) pb
- ⑧ Focus Mode sw
- ⑨ EXP. LOCK pb
- ⑩ SHUTTER/K tw
- ⑪ PUSH AF pb
- ⑫ Aperture Ring
- ⑬ Zoom Ring
- ⑭ Focus Ring

jsc48037\_162.cvx



# CANON G1 (Continued)

## NOMENCLATURE (Continued)

### CAMCORDER – LEFT SIDE REAR SECTION

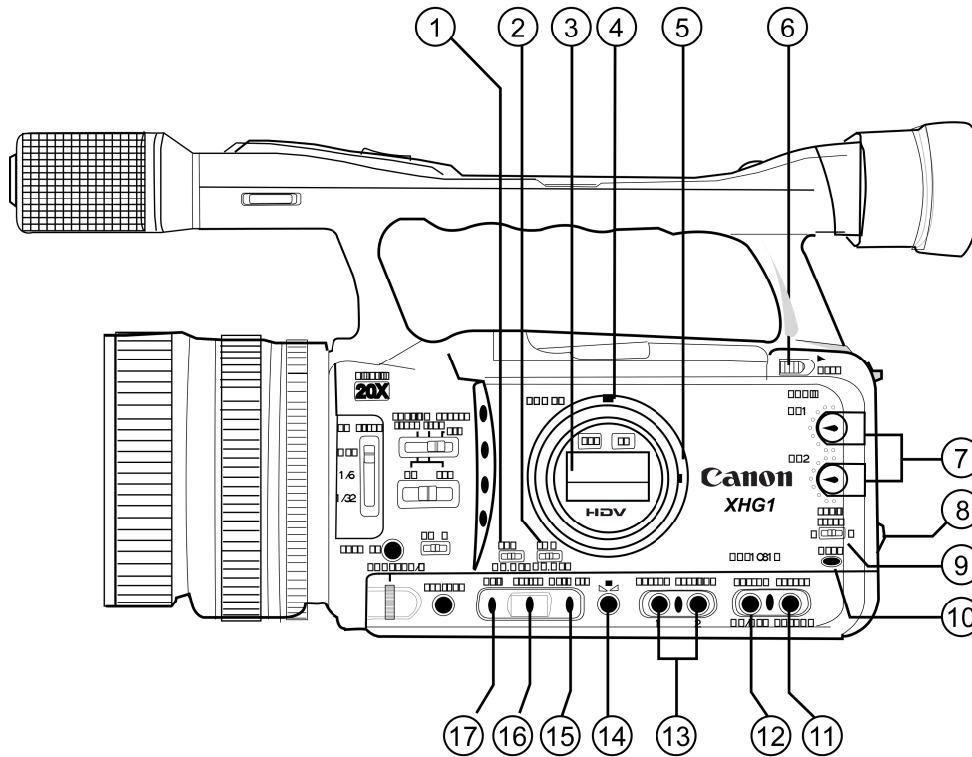

- ① AGC sw (Automatic Gain Control)
- ② AWB sw (Automatic White Balance)
- ③ Side Panel Display
- ④ POWER Indicator
- ⑤ POWER Dial
- ⑥ OPEN sw (open the LCD display)
- ⑦ **AUDIO** CH1/CH2 Dials
- ⑧ SELECT/SET Dial
- ⑨ AUDIO LEVEL sw
- ⑩ MENU pb
- ⑪ CUSTOM PRESET SELECT pb
- ⑫ CUSTOM PRESENT ON/OFF pb
- ⑬ CUSTOM KEY pb
- ⑭ WHITE BAL  pb (White Balance)
- ⑮ WHITE BAL sw
- ⑯ OUTPUT sw
- ⑰ GAIN sw

jsc48037\_163.cvx

# CANON G1 (Continued)

## NOMENCLATURE (Continued)

### CAMCORDER – PWR DIAL

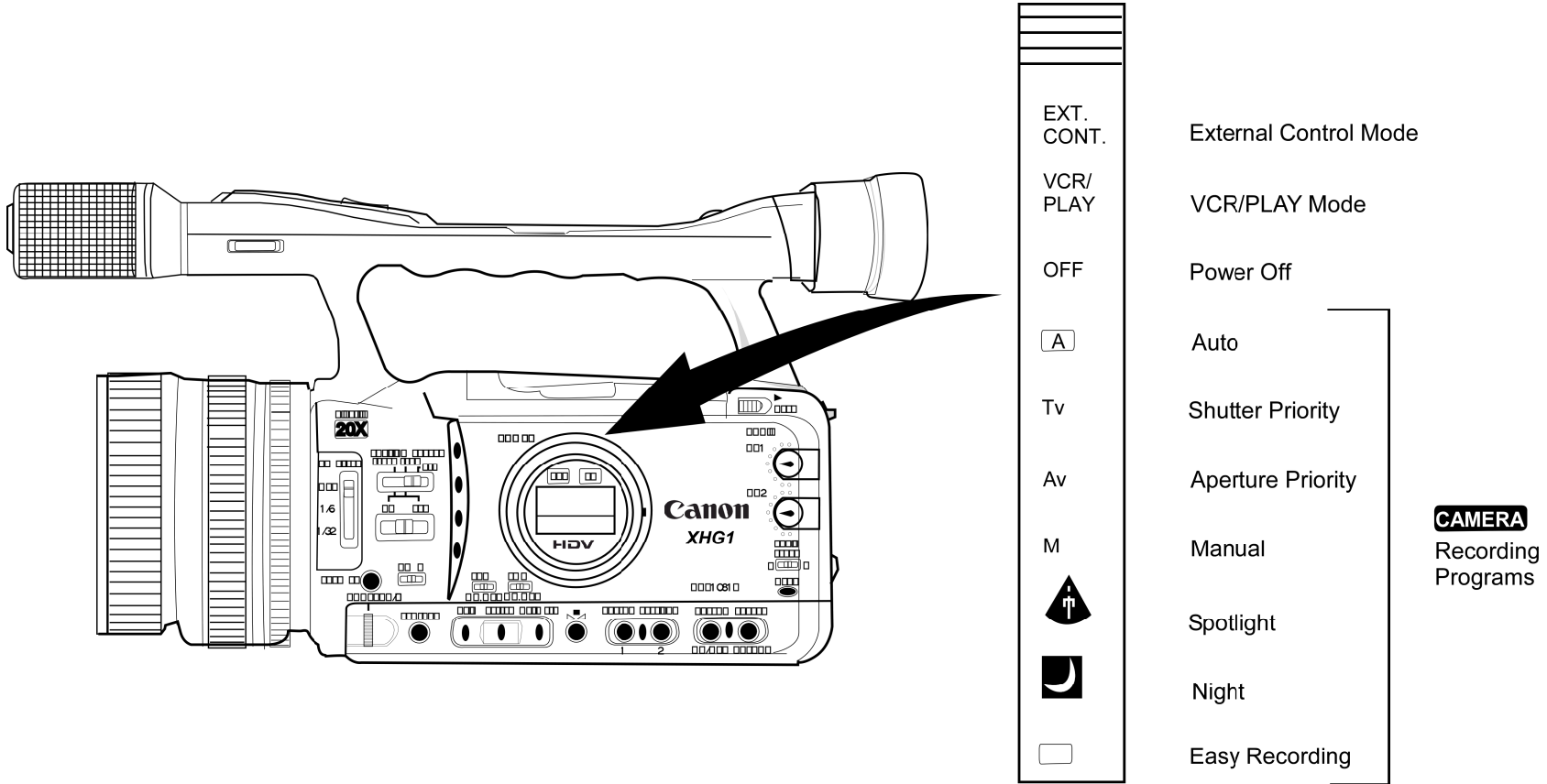



jsc48037\_164.cvx

# CANON G1 (Continued)

## NOMENCLATURE (Continued)

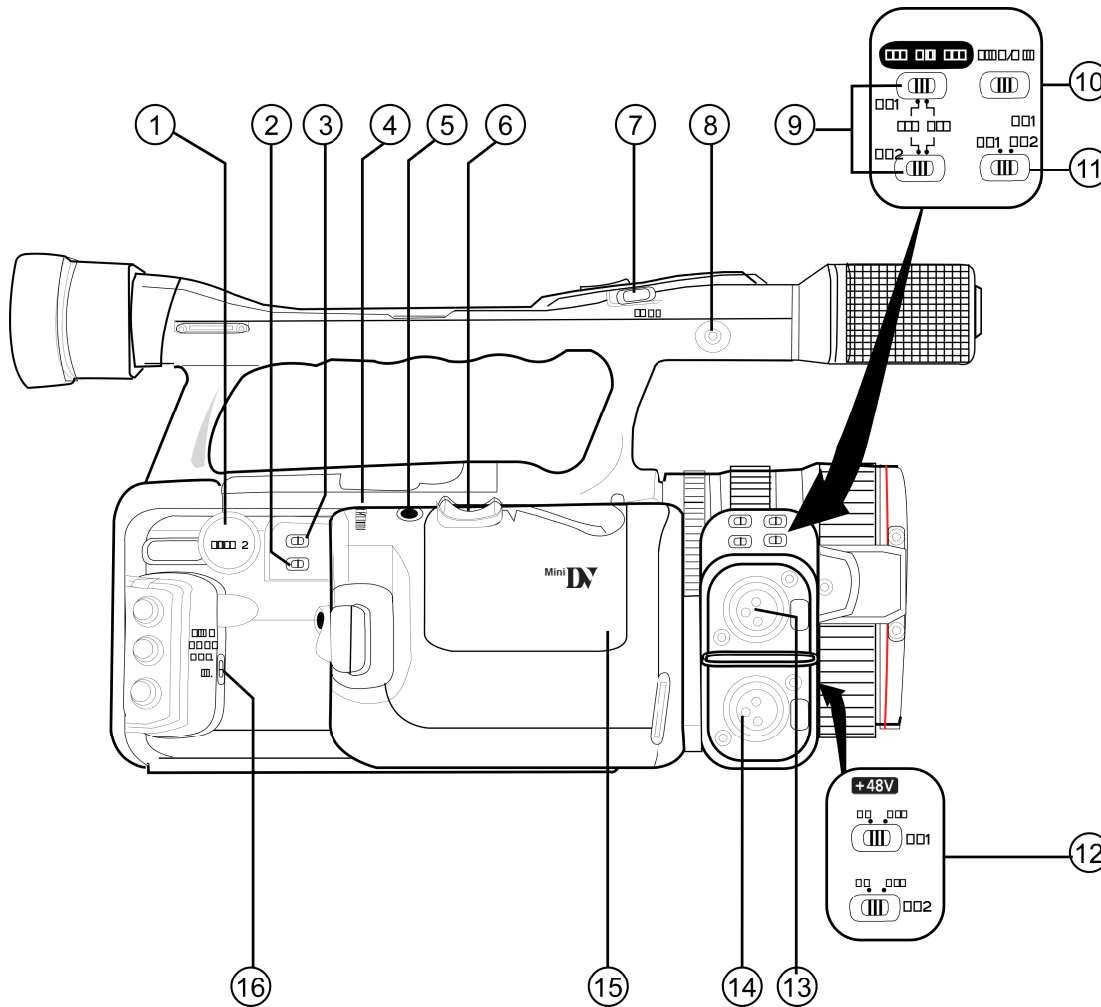
### CAMCORDER – RIGHT SIDE





- ① V2 Terminal
- ② ZOOM SPEED sw
- ③ Card/Tape sw 
- ④ Zoom Speed Adjustment Dial
- ⑤ PHOTO pb
- ⑥ Grip Zoom
- ⑦ LOCK sw
- ⑧ MIC (External Microphone) Terminal
- ⑨ XLR MIC ATT. sw
- ⑩ LINE/MIC sw
- ⑪ Input Channel Selection sw
- ⑫  +48V sw
- ⑬ CH1 Input Terminal
- ⑭ CH2 Input Terminal
- ⑮ Cassette Compartment
- ⑯ TIME CODE sw

# CANON G1 (Continued)

## NOMENCLATURE (Continued)

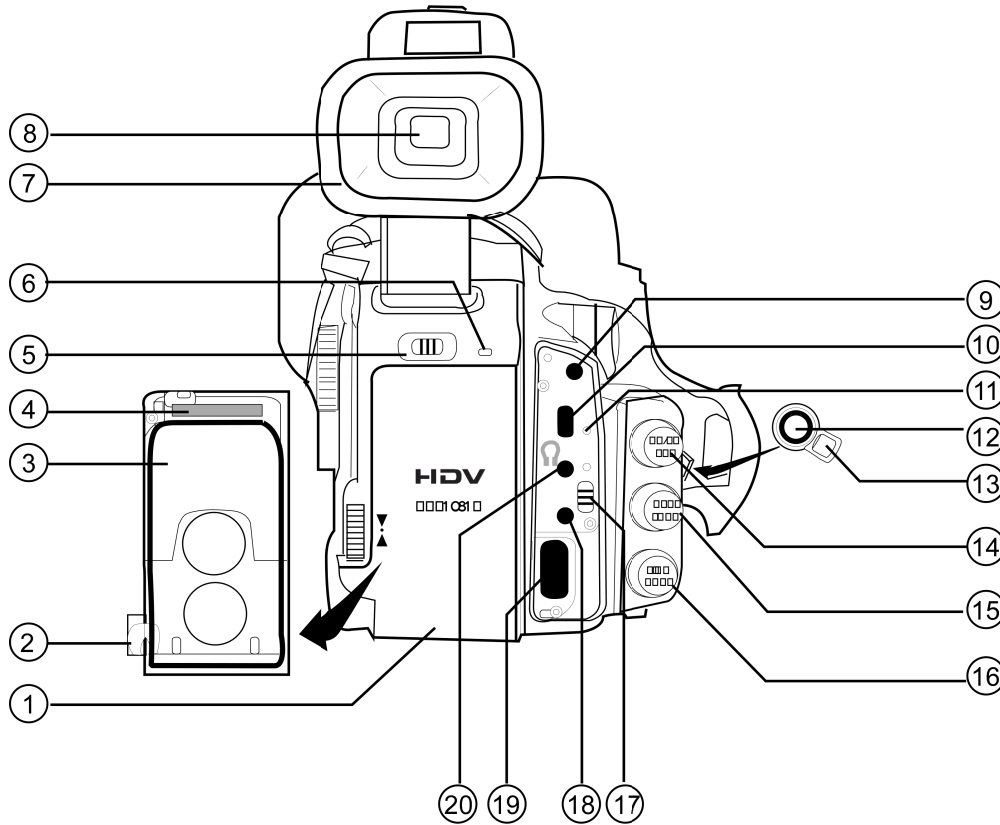
### CAMCORDER – BACK VIEW



- ① Battery/Memory Card Compartment
- ② BATT. RELEASE Latch
- ③ Battery Attachment Unit
- ④ Memory Card Slot
- ⑤ OPEN sw (Battery Compartment)
- ⑥ CARD Access Indicator
- ⑦ Diopic Adjustment Lever
- ⑧ Viewfinder
- ⑨  Terminal
- ⑩ HDV/DV Terminal
- ⑪ HDV Indicator
- ⑫ Start/Stop pb
- ⑬ Standby/Lock Lever
- ⑭ HD/SD SDI Terminal
- ⑮ GENLOCK Terminal
- ⑯ TIME CODE Terminal
- ⑰ AV1/AV2 sw
- ⑱ AV1 Terminal
- ⑲ COMPONENT OUT Terminal
- ⑳  Headphones Terminal

jsc48037\_166.cvx

**CANON G1 (Continued)**

**NOMENCLATURE (Concluded)**

CAMCORDER – FRONT VIEW

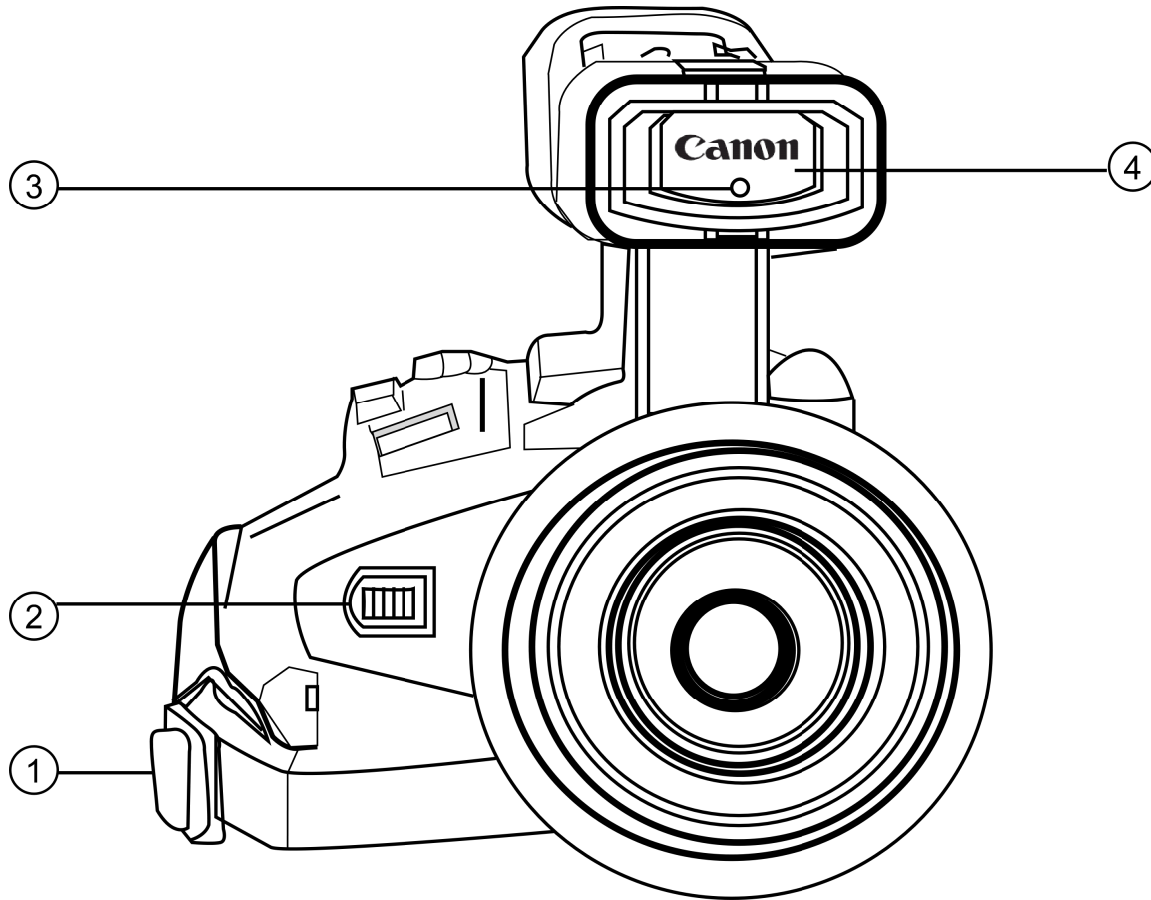

- ① Grip Belt
- ② Instant AF External Sensor
- ③ Tally Lamp
- ④ Remote Sensor

jsc48037\_167.cvx

## CANON G1 (Continued)

### NOMINAL MENU SETTINGS

#### CAMR MENU (\* – non-default)

##### SIGNAL SETUP

###### TIME CODE

FRAME SETTING – DROP  
COUNT-UP – REC-RUN  
GENLOCK ADJUST – 0000  
SIGNAL STD – HD  
FRAME RATE – 60i  
COMP. OUT – 1080i/480i  
SDI OUTPUT – OFF  
SPEC. – AUTO

##### CAMERA SETUP

AE SHIFT – ±0  
GAIN SETTING  
GAIN L – ±0dB  
M – 6dB  
H – 12dB  
AF MODE – NORMAL AF\*  
IMG STAB – ON ()  
SKIN DETAIL  
EFFECT LEVEL – OFF  
SKY DETAIL – OFF  
COLOR CORR.  
CORRECT – OFF  
F SPEED PSET – HIGH

##### RECORDING SETUP

DV REC MODE – SP (Standard Definition Mode Only)  
UB REC – INT. USB-BIT  
SELECT – 00 00 00 00  
IMG QUALITY – FINE  
IMAGE SIZE – LW1920x1080  
FILE NOS. – CONTINUOUS

##### AUDIO SETUP

DV AUDIO – 16 bit (Standard Definition Mode Only)  
AUD. M. SET – NORMAL  
MIC MODE – NORMAL  
SENS. – NORMAL  
XLR INPUT – OFF  
GAIN UP – OFF

##### DISPLAY SETUP

###### CVF SETUP

BRIGHTNESS – mid  
CONTRAST – mid  
COLOR – mid  
SHARPNESS – mid  
BACKLIGHT – NORMAL

###### LCD SETUP

BRIGHTNESS – mid  
CONTRAST – mid  
COLOR – mid  
SHARPNESS – mid  
BACKLIGHT – NORMAL

CVF+LCD BW – OFF  
ON – OFF

LANGUAGE – ENGLISH

MARKERS – OFF

ASPECT GUIDE – 4:3\*

SAFETY ZONE – OFF

ZEBRA – OFF

LEVEL – 85

TV SCREEN – OFF\*

AUDIO LEVEL – ON

GUIDE INFO – CUSTOM KEYS

UB DISPLAY – OFF

## CANON G1 (Continued)

### NOMINAL MENU SETTINGS (Continued)

#### CAMR MENU (\* – non-default) (Continued)

##### SYSTEM SETUP

CUSTOM KEY 1 – SHTR D.LOCK\*  
2 – (NONE)\*

##### D/TIME SET

T.ZONE/DST – LONDON\*  
DATE/TIME – ‘GMT’\*  
DATE FORMAT – ‘M.D.Y.TIME’  
DV CONTROL – OFF  
MAGN. B. LOCK – ACTIVE\*  
SHTR D. LOCK – DISABLED  
RESET ALL – NO

##### CUSTOMIZE

##### CUSTOM PRESET

FOR CP1 thru CP9 w/CP1 SELECTED

GAMMA – NORMAL  
KNEE – AUTO  
BLACK – MIDDLE  
MASTER PED – 0  
SETUP LEVEL – 0  
SHARPNESS – -3\*  
H DTL FREQ – MIDDLE  
DTL HV BALANCE – 0  
CORING – 0  
NR1 – OFF  
NR2 – OFF  
COLOR MAT. – NORMAL  
COLOR GAIN – 6\*  
COLOR PHASE – -6\*  
R GAIN – 1\*  
G GAIN – 2\*  
B GAIN – -1\*

##### CUSTOMIZE (Continued)

##### CUSTOM PRESET (Concluded)

RG MATRIX – 2\*  
RB MATRIX – 0  
GR MATRIX – 0  
GB MATRIX – 1\*  
BR MATRIX – 0  
BG MATRIX – -4\*

##### FUNCTION – C.Fn1 Active\*

##### SETTING ITEMS

00 SHCKLSS WB/GN – 00  
01 AE RESPONSE – 00  
02 HIGH-SPEED ZOOM – 00  
03 FOCUS RING CTRL – 01\*  
04 BUTTONS OPER. – 00  
05 RINGS DIRECTION – 00  
06 DIALS DIRECTION – 00  
07 FOCUS PRIORITY – 00  
08 SIMULT.IMG.REC – 00  
09 MARKER LEVEL – 00  
10 F. AST BW-MOD – 00  
11 OBJ DST UNIT – 00  
12 ZOOM INDICATOR – 00  
13 COLOR BARS – 00  
14 1kHz TONE – 00  
15 WIRELESS REMOTE – 00  
16 POWER SAVE – 01\*  
17 TALLY LAMP – 02\*  
18 LED – 00  
19 BEEP – 00  
20 CHARACTER REC – 00

## CANON G1 (Continued)

### NOMINAL MENU SETTINGS (Continued)

#### CAMR MENU (Concluded)

##### CUSTOMIZE (Concluded)

##### CUSTOM DISPLAY

##### SETTING ITEMS (\*non-default)

- 00 REC PROGRAMS – 01
- 01 CAMERA DATA1 – 03
- 02 CAMERA DATA2 – 07
- 03 ZOOM – 01
- 04 FOCUS – 02\*
- 05 ND – 01
- 06 IMAGE EFFECTS – 07
- 07 F. ASSIST FUNC. – 03
- 08 CUSTOMIZE – 03
- 09 RECORDING STD – 01
- 10 DV REC MODE – 00
- 11 FRAME RATE – 01
- 12 TAPE – 03
- 13 TAPE REMAINDER – 01\*
- 14 TAPE/CARD – 02\*
- 15 LIGHT METERING – 03
- 16 CARD – 03
- 17 CARD REMAINDER – 02
- 18 AUDIO – 00
- 19 CONDENSATION – 01
- 20 BATTERY – 01\*
- 21 WIRELESS REMOTE – 02

#### VCR MENU (\* – non-default)

##### SIGNAL SETUP

##### TIME CODE

- FRAME SETTING – DROP
- COUNT-UP – REC RUN
- HDV/DV IN – REGEN.
- PLAYBACK STD – AUTO
- COMP. OUT – 1080i/480i
- SDI OUTPUT – OFF
- SPEC. – AUTO
- AV->DV – OFF
- HD DOWN-CONV – ON
- LETTERBOX – OFF

##### RECORDING SETUP

- DV REC MODE – SP
- UB SELECT -- 00 00 00 00
- IMG QUALITY – FINE
- HD IMG SIZE -- LW1920x1080
- FILE NOS. – CONTINUOUS

##### AUDIO SETUP

- SEL AUDIO CH – CH1/3 / CH2/4
- AUD. M. SET – CH1/2
- DV AUDIO – 16 bit



## CANON G1 (Continued)

### NOMINAL MENU SETTINGS (Concluded)

#### VCR MENU (\* – non-default) (Concluded)

##### DISPLAY SETUP

##### CVF SETUP

BRIGHTNESS – mid  
CONTRAST – mid  
COLOR – mid  
SHARPNESS – mid  
BACKLIGHT – NORMAL

##### LCD SETUP

BRIGHTNESS – mid  
CONTRAST – mid  
COLOR – mid  
SHARPNESS – mid  
BACKLIGHT – NORMAL

CVF+LCD BW – OFF  
ON- OFF

TV SCREEN – OFF  
AUDIO LEVEL – ON  
LANGUAGE – ENGLISH  
CUSTOM KEY – OFF  
DATA CODE – DATE & TIME  
6SEC. DATE – OFF  
UB DISPLAY – OFF

##### SYSTEM SETUP

CUSTOM KEY 1 – TV SCREEN  
2 – DATA CODE

##### D/TIME SET

T.ZONE/DST – LONDON  
DATE/TIME – 'GMT'  
DATE FORMAT – 'M.D.Y.TIME'  
RESET ALL – NO

##### CUSTOM FUNCTION – C.FN1

##### SETTING ITEMS (\*NON-DEFAULT)



00 SHCKLSS WB/GN – 00  
01 AE RESPONSE – 00  
02 HIGH-SPEED ZOOM – 00  
03 FOCUS RING CTRL – 01\*  
04 BUTTONS OPER. – 00  
05 RINGS DIRECTION – 00  
06 DIALS DIRECTION – 00  
07 FOCUS PRIORITY – 00  
08 SIMULT.IMG.REC – 00  
09 MARKER LEVEL – 00  
10 F. AST BW-MOD – 00  
11 OBJ DST UNIT – 00  
12 ZOOM INDICATOR – 00  
13 COLOR BARS – 00  
14 1kHz TONE – 00  
15 WIRELESS REMOTE – 00  
16 POWER SAVE – 01\*  
17 TALLY LAMP – 02\*  
18 LED – 00  
19 BEEP – 00  
20 CHARACTER REC – 00

## CANON G1 (Continued)

### MANUAL SETTINGS

#### FOCUS

##### MANUAL FOCUS

PWR dial – **A** (Tv,Av,M, , )  
AF/M sw – MANUAL (MF display in viewfinder (LCD))  
Zoom – IN to subject  
Focus manually  
Zoom to desired setting  
Begin recording as reqd





##### TEMP AUTO FOCUS

PUSH AF pb – press,hold for temp Auto Focus





#### SHUTTER SPEED

PWR dial – **A** (Tv,M)  
If **A** , EXP.LOCK pb – push  
SHUTTER/K tw – rotate to select SS from 1/4 to 1/15,000 sec, CS  
If **A** , to exit Shutter Speed:  
EXP.LOCK pb – push  
√No SS displayed

#### WHITE BALANCE

PWR dial – **A** (Tv,Av,M, , )  
AWB – OFF  
WHITE BAL – A(B,PRE)  
For A(B):  
To set WHT BAL, place white sheet of paper in CC FOV (under same lighting conditions)  
 tw – push  
White Balance icon  A(B) will blink for 2 sec and become steady

#### WHITE BALANCE (Concluded)

For PRE:  
WHITE BAL PRESET –  ( , **K** )  
For **K**:  
 pb – push (flashing #K)  
SHUTTER/K tw – rotate to desired color temperature  
 pb – push (solid #K)

#### APERTURE

PWR dial – **A** (Av,M)  
If **A** , EXP.LOCK pb – push  
Aperture Ring – rotate to select AP from F1.6 to F9.5  
PROGRAM AE pb – press  
If **A** , to exit Aperture:  
EXP.LOCK pb – push  
√No F# displayed

#### GAIN

PWR dial – **A** (Tv,Av,M)  
AGC – OFF  
GAIN – L(M,H) as reqd  
√+/- #dB displayed on LCD(Viewfinder)

# CANON G1 (Continued)

## ANALOG (SD DTV) CC REC,DNLK

Config H/W per dwg at right

AVIU SYNC/VIDEO – VIDEO  
 HI-Z/75 – 75  
 PWR SELECT – LO

O19(MO58F) √TV PWR – ON

CC √Wide Conversion lens installed  
 √ND FILTER – OFF  
 Install Audio Muting Plug (optional)  
 √OUTPUT – CAM  
 √A/V1/V2 – V2  
 √...-  
 √STANDBY/LOCK – STANDBY

PWR dial – "green"

If rec to tape:

Tape – Install

√Viewfinder (LCD) displays "green" •||  
 Mount w/Multiuse Brkt, Clamp

**CAUTION**

Due to temp constraints, worklights at full pwr for 60 min; 90% pwr for unlimited time

Worklights Install fresh BATTs  
 Mount light(s) w/Brackets (Velcro/tape)  
 Pwr – as reqd

Cabin Lts Flt Deck – ON  
 Lts in FOV – OFF as reqd  
 Lt Shades – install as reqd  
 Window Shades – install as reqd

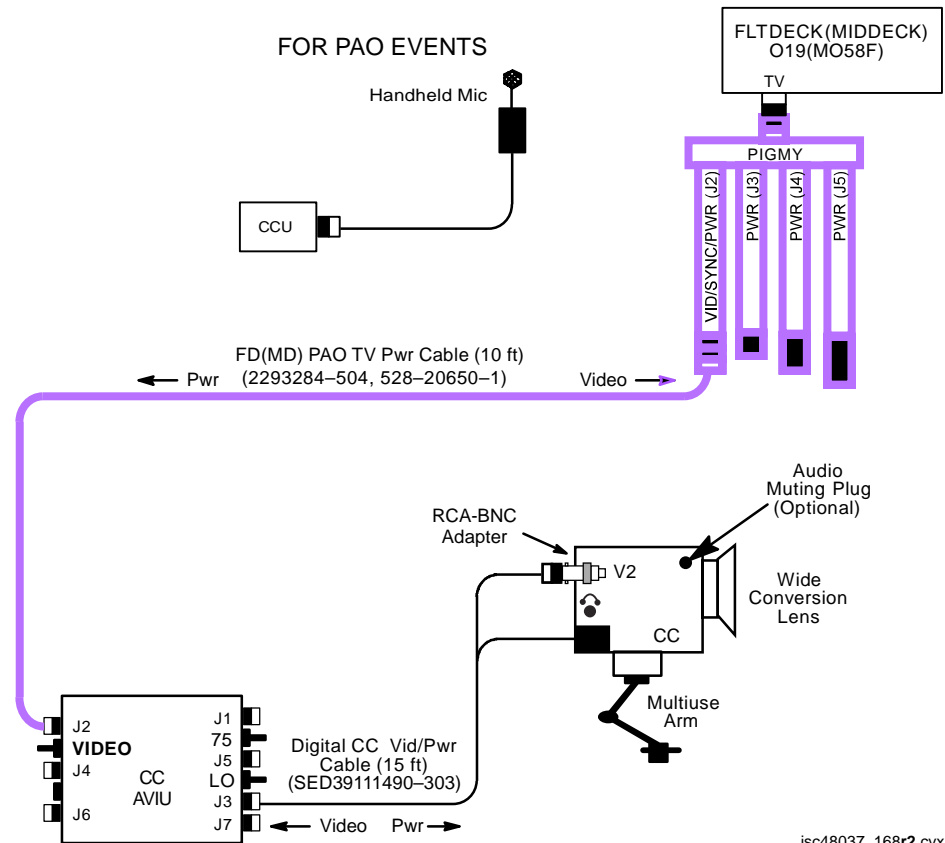
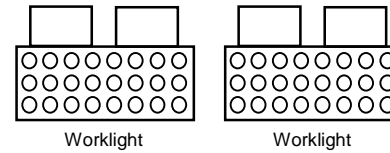

## CANON G1 (Continued)

### ANALOG (SD DTV) CC REC,DNLK (Concluded)

CC           √Scene composition  
              Adjust Camr angle for best framing

CCU           CCU PWR – ON

ATU           PWR – AUD  
              A/G 1(2) – T/R  
              All Other Loops – OFF  
              XMIT/ICOM MODE SEL – PTT/PTT  
              MSTR SPKR VOL SEL – as reqd

A7            When ready for dnlk:  
              √TV DNLK – ENA  
              PWR CNTL – PNL  
              CONTR UNIT – MNA(B)  
              CNTL – CMD (wait 10 sec for system initialization)

              If ANALOG, On MCC GO:  
              | VID OUT DNLK pb – push  
              | IN FLT DECK(MIDDECK) pb – push

              If SD DTV, On MCC GO:  
L10 (MUX)   √CABLES CONNETED  
              MUX/VTR/CC PWR – on (LED on)  
              √MUX BYPASS – ACT  
              (VIP)   PWR – on (LED on, DATA FLOW LED flashes twice)  
              (VTR)   √ON/STANDBY LED – green  
              √INPUT SELECT – VIDEO

A7            VID OUT DTV pb – push  
              IN FLT DECK(MIDDECK) pb – push

L10 (MUX)   √CHANNEL 3 DATA LED – on  
              When dnlk complete:

CC            PWR dial – OFF  
Worklights   PWR – OFF  
O19           TV PWR – OFF  
L10 (MUX)    MUX/VTR/CC PWR – off(LED off)  
              Go to DEACTIVATION (Cue Card, TV) as reqd

# CANON G1 (Continued)

## HD DIGITAL CC DNLK

- Notify MCC, configuring for HD TV dnlk
- Config H/W per dwg at right
- CC For cable strain relief attach MPC-to-G1 Cable Velcro strap to CC strap
- AVIU SYNC/VIDEO – VIDEO  
HI-Z/75 – 75  
PWR SELECT – LO
- O19 √TV PWR – ON
- CC √Wide Conversion Lens installed  
Install LAV MIC  
√ND FILTER – OFF  
√OUTPUT – CAM  
√...-  
√STANDBY/LOCK – STANDBY  
PWR dial – "green"   
If rec to tape  
Tape – Install  
√Viewfinder (LCD) display "green" •||  
Mount w/Multiuse Bracket, Clamp as reqd
- L10 (MUX) √MUX/VTR/CC PWR – on (LED on)  
√MUX BYPASS – ACT  
√CHANNEL 0,1 RATE SEL – 1  
    √2 RATE SEL – 8
- (VTR) ON/STANDBY pb – push (LED red)
- (VIP) PWR – off (LED off)
- O19 DC UTIL PWR MNA – ON
- MPC PWR SPLY DC PWR SPLY PWR SW1 – ON
- MPC PWR-ON (HDV, TAXI, 5V, 3V green LEDs on)

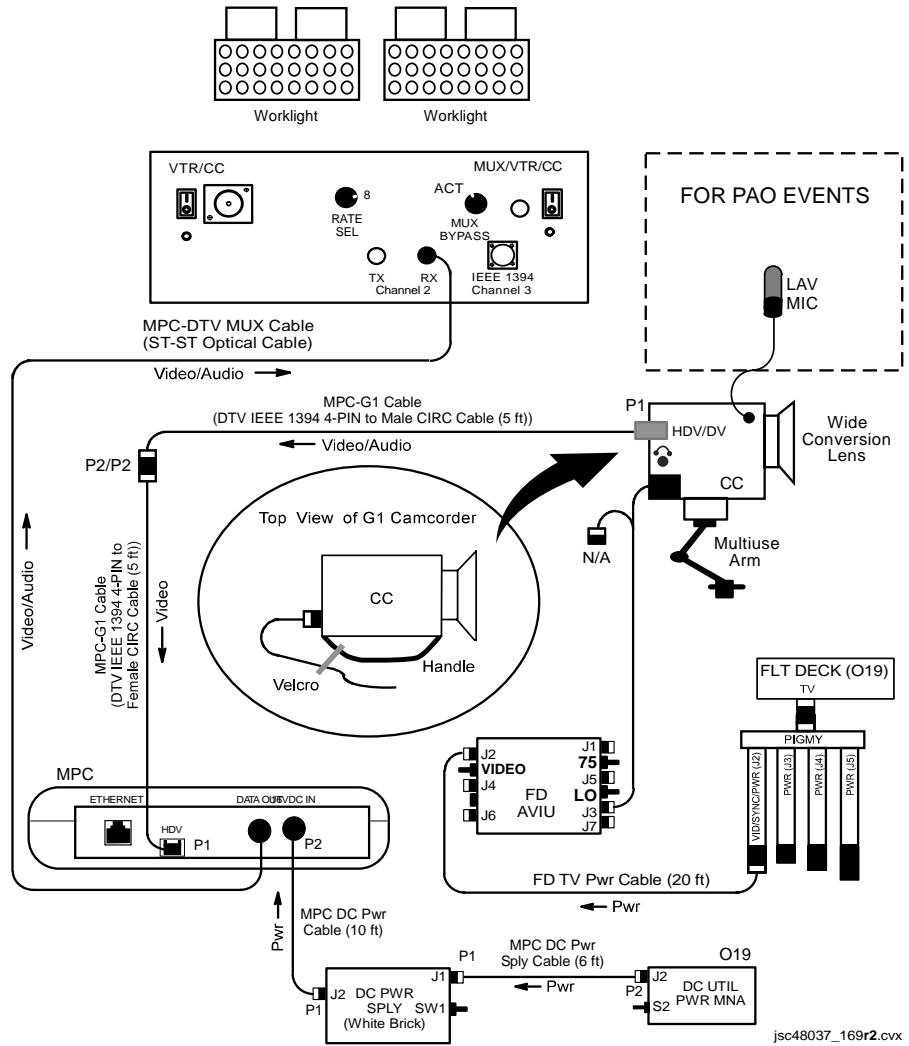

## CANON G1 (Continued)

### HD DIGITAL CC DNLK (Continued)

L10 (MUX)    √CHANNEL 2 F/O OK, DATA LEDES on

**CAUTION**

Due to temp constraints, worklights at full  
pwr for 60 min; 90% pwr for unlimited time

Worklights    Install fresh BATTs  
Mount light(s) w/Brackets (Velcro/tape)  
PWR – as reqd

Cabin Lts    Flt Deck – ON  
Lts in FOV – OFF as reqd  
Lt Shades – install as reqd  
Window Shades – install as reqd

CC            √Scene composition

Adjust Camr angle for best framing

LAV MIC    PWR – ON (talk), OFF (listen)

√MCC if BLACK VIDEO and COLOR BARS reqd

CC            If reqd:  
PWR dial – AV  
APERTURE – CLOSE (AFT RING)  
√Av CLOSE displayed on top left of LCD  
AGC – OFF  
√GAIN sw – L  
√± Odb displayed on LCD  
OUTPUT – BARS

When MCC says done w/bars:  
OUTPUT – CAM

When MCC says done w/black screen test:  
PWR dial – “green”

	When dnk complete:
CC	PWR dial – OFF
Worklights	PWR – OFF
O19	TV PWR – OFF as reqd
MPC	PWR – OFF
PWR	DC PWR SPLY PWR SW1 – OFF
SPLY	
O19	DC UTIL PWR MNA – OFF
L10 (MUX)	MUX/VTR/CC PWR – off (LED off)
(VIP)	PWR – on (LED on, DATA FLOW LED flashes, twice)
(VTR)	ON/STANDBY pb – push (LED green)
	Notify MCC, returned to SD DTV dnk
	Go to DEACTIVATION (Cue Card, <u>TV</u> ) as reqd

This Page Intentionally Blank



## CANON G1 (Continued)

### CC BATT CHARGING

1. Config H/W per dwg below
- AVIU
2. SYNC/VIDEO – VIDEO  
HI-Z/75 – 75  
PWR SELECT – HI

#### NOTE

When batt charger not in use, remove pwr

- O19  
(MO58F)
3. √TV PWR – ON
  4. Insert Batt in charger. Check charger LED for charge status (~2 hr)

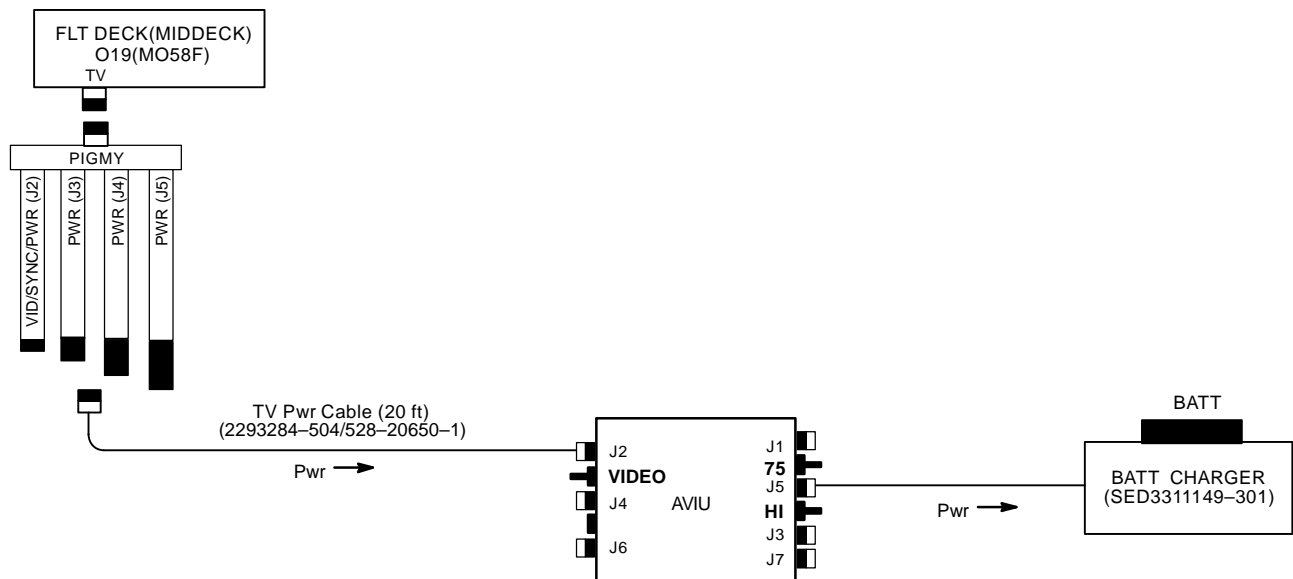

jsc48037\_093.cnv

# CANON G1 (Continued)

## G1 TO G1 VIA FIREWIRE

Config H/W per dwg at right

AVIU (two) SYNC/VIDEO – VIDEO  
 HI-Z/75 – 75  
 PWR SELECT – LO

PLBK CC PWR dial – VTR/PLAY  
 Install source tape. Protect Tab – slide (red visible)  
 Cue tape to desired take via FF(REW) pb  
 PLAY pb – push  
 || pb – push

RCD CC PWR dial – VTR/PLAY  
 Install new tape  
 REC pb – push  
 || pb – push

PLBK CC Perform following for each video segment:  
 || pb – push (To PLAY)  
 RCD CC || pb – push (To REC)

PLBK CC When EDIT segment complete:  
 || pb – push (PAUSE)  
 RCD CC || pb – push (PAUSE)

When complete:  
 STOP pb – push simo  
 Cue to next starting point and repeat as reqd

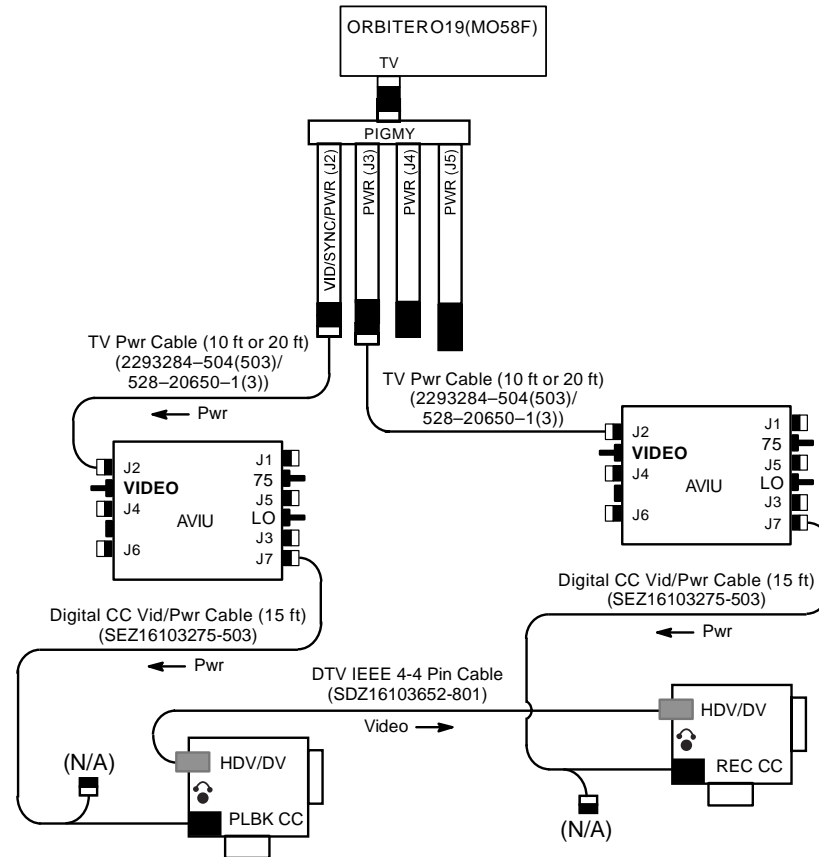

jsc48037\_170r1.cvx

## CANON G1 (Continued)

### G1 TO V10 VIA FIREWIRE

- Config H/W per dwg at right
- AVIU (two) SYNC/VIDEO – VIDEO  
HI-Z/75 – 75  
PWR SELECT – LO
- CC PWR dial – VTR/PLAY  
Disconnect DTV IEEE 4-4 Pin Cable  
MENU pb – push  
SELECT/SET:  
    Sel 'SIGNAL SETUP'  
    HD DOWN-CONV – ON  
MENU pb – push  
Reconnect DTV IEEE 4-4 Pin Cable  
Install source tape. Protect Tab – slide (red visible)  
Cue tape to desired take via FF(REW) pb  
PLAY pb – push  
|| pb – push
- V10 PWR – ON  
DISPLAY pb – push  
Install new tape  
REC (two) pb – push simo  
PAUSE pb – push
- CC Perform following for each video segment:  
|| pb – push (To PLAY)
- V10 PAUSE pb – push (To REC)
- CC When EDIT segment complete:  
|| pb – push (PAUSE)
- V10 PAUSE pb – push (PAUSE)
- When complete:  
STOP pb – push simo  
Cue to next starting point and repeat as reqd

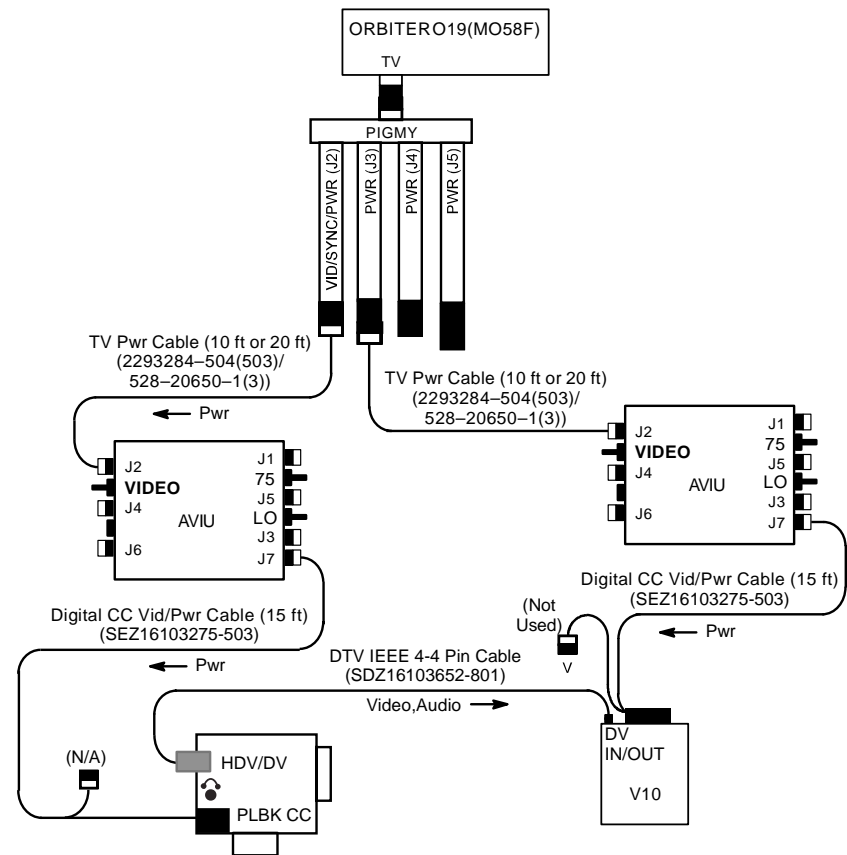

jsc48037\_171r1.cvx

# CANON G1 (Continued)

## G1 TO V10 VIA ORBITER TV SYSTEM

Config H/W per dwg at right  
 ✓Orbiter in async mode  
 Perform ACTIVATION (Cue Card, TV)

AVIU SYNC/VIDEO – VIDEO  
 HI-Z/75 – 75  
 PWR SELECT – LO

O19(MO58F) ✓TV PWR – ON

CC PWR dial – VTR/PLAY  
 ✓AV1/V2 – V2  
 Install source tape, Protect Tab – slide (red visible)  
 Cue tape to desired take via FF(REW) pb  
 PLAY pb – push  
 || pb – push

V10 PWR – ON  
 DISPLAY pb – push  
 Install new tape  
 REC pb – push  
 PAUSE pb – push

A7 VID OUT MON 1(2) pb – push  
 IN FLT DECK(MIDDECK) pb – push

CC Perform following for each video segment:  
 || pb – push (To PLAY)  
 PAUSE pb – push (To REC)

When EDIT segment complete:

CC || pb – push (PAUSE)  
 V10 PAUSE pb – push (PAUSE)

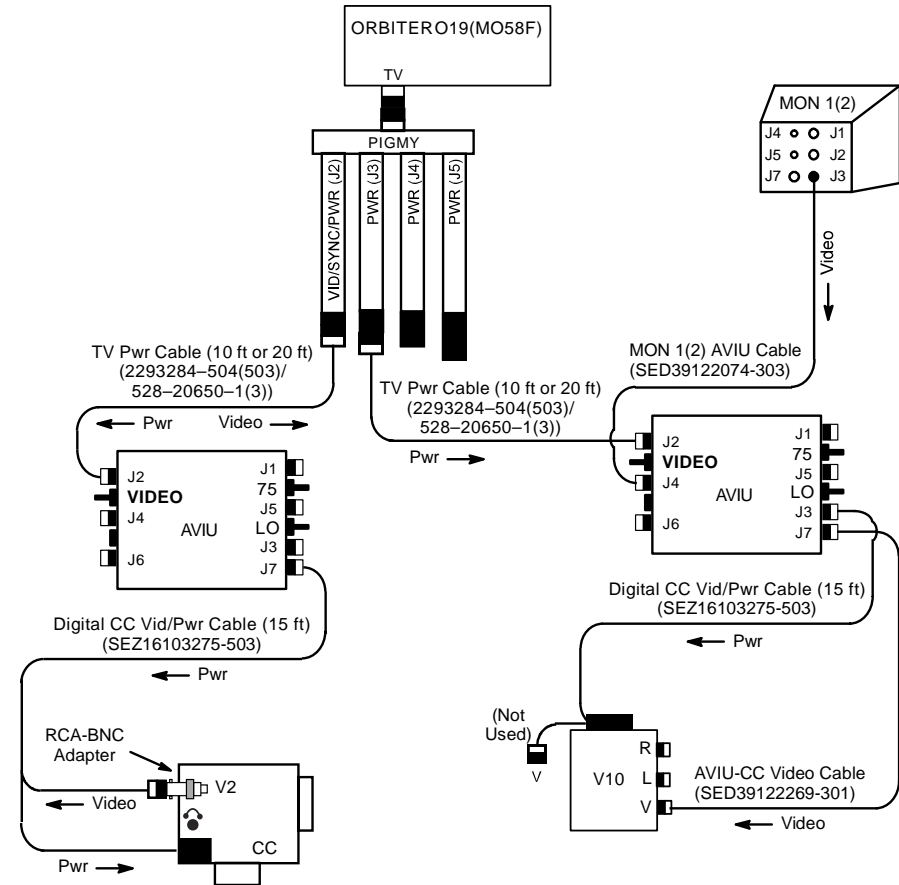

jsc48037\_172r1.cvx

## CANON G1 (Continued)

### G1 TO DSR-25 VTR

- Config H/W per dwg at right
- L10 (MUX)  
(VTR)     √VTR/CC PWR – on (LED on)  
                  √ON/STANDBY LED – green  
                  INPUT SELECT – DV  
                  Install new tape  
                  REC pb – push,hold  
                  PLAY pb – push, simo (red dot displayed on LCD)  
                  PAUSE pb – push
- CC            PWR dial – VTR/PLAY  
                  Disconnect DTV IEEE 1394 Cable  
                  MENU pb – push  
                  SELECT/SET:  
                    Sel 'SIGNAL SETUP'  
                    HD DOWN-CONV – ON  
                  MENU pb – push  
                  Reconnect DTV IEEE 1394 Cable  
                  Install source tap, Protect Tab – slide (red visible)  
                  Cue tape to desired take via FF(REW) pb  
                  PLAY pb – push  
                  || pb – push
- CC            Perform following for each video segment:  
L10 (VTR)     || pb – push (To PLAY)  
                  PAUSE pb – push (To REC)
- CC            When EDIT segment complete:  
L10 (VTR)     || pb – push (PAUSE)  
                  PAUSE pb – push (PAUSE)
- When complete:  
                  INPUT SELECT – VIDEO  
                  Remove,mark tape  
                  ON/STANDBY pb – push (red LED on)  
                  Remove, stow IEEE 1394 female cable  
                  VTR/CC PWR – off (LED off) as reqd  
                  Reconnect IEEE 1394 male cable to IEEE 1394 connector
- (MUX)

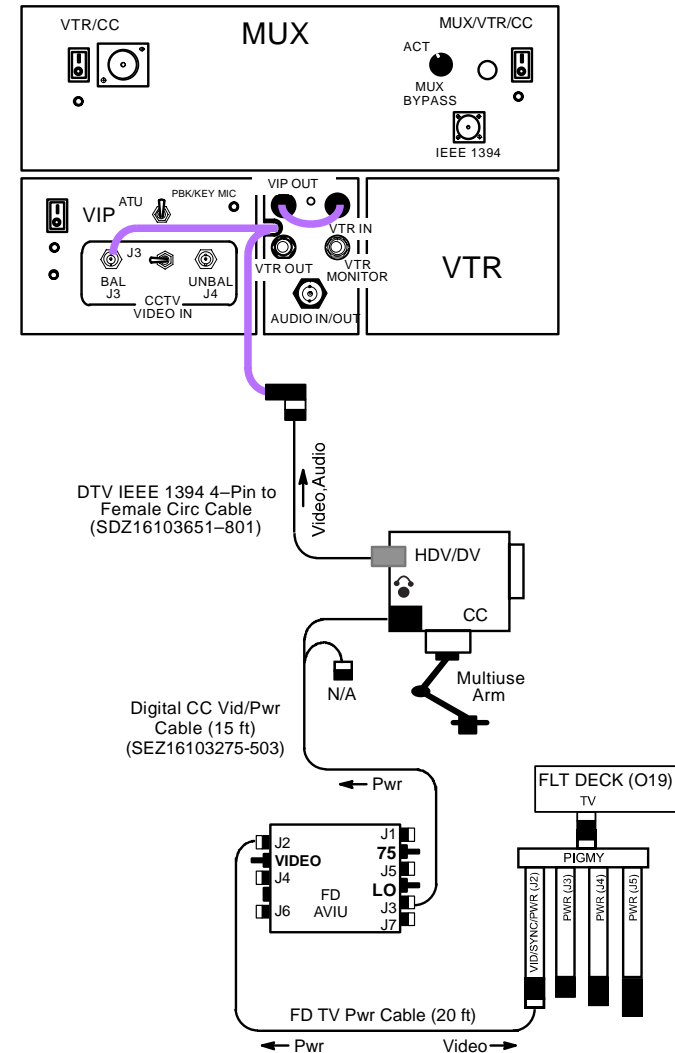

jsc48037\_173r1.cvx

# CANON G1 (Concluded)

## SINGLE CAMCORDER W/CAMCORDER MICROPHONE

- Config H/W per dwg at right
  - AVIU SYNC/VIDEO – VIDEO  
HI-Z/75 – 75  
PWR SELECT – LO
  - O19(MO58F) ✓TV PWR – ON
  - CC ✓Wide Conversion Lens installed  
✓ND FILTER – OFF  
✓AF/M – AF  
✓AGC – OFF  
✓GAIN – L(M)  
✓OUTPUT – CAM  
✓AWB – ON  
✓A/V1/V2 – V2  
✓  ..  -
  - ✓STANDBY/LOCK – STANDBY  
PWR dial – A  
✓CP1(2-9) displayed on LCD (VIEWFINDER)  
Tape – Install  
✓Viewfinder (LCD) displays “green” •||  
Multiuse Brkt, Clamp
  - Lav Mic ON/OFF – ON
- CAUTION**

Due to temp constraints, worklights at full pwr for 60 min; 90% pwr for unlimited time
- Worklights Install fresh BATTs  
Mount light(s) w/Brackets (Velcro/tape)  
PWR – as reqd
  - Cabin Lts Flt Deck(Middeck) – ON  
Lts in FOV – Off as reqd  
Lt Shades – install as reqd
  - CC ✓Scene Composition  
Adjust Camr for best framing  
✓Audio Quality

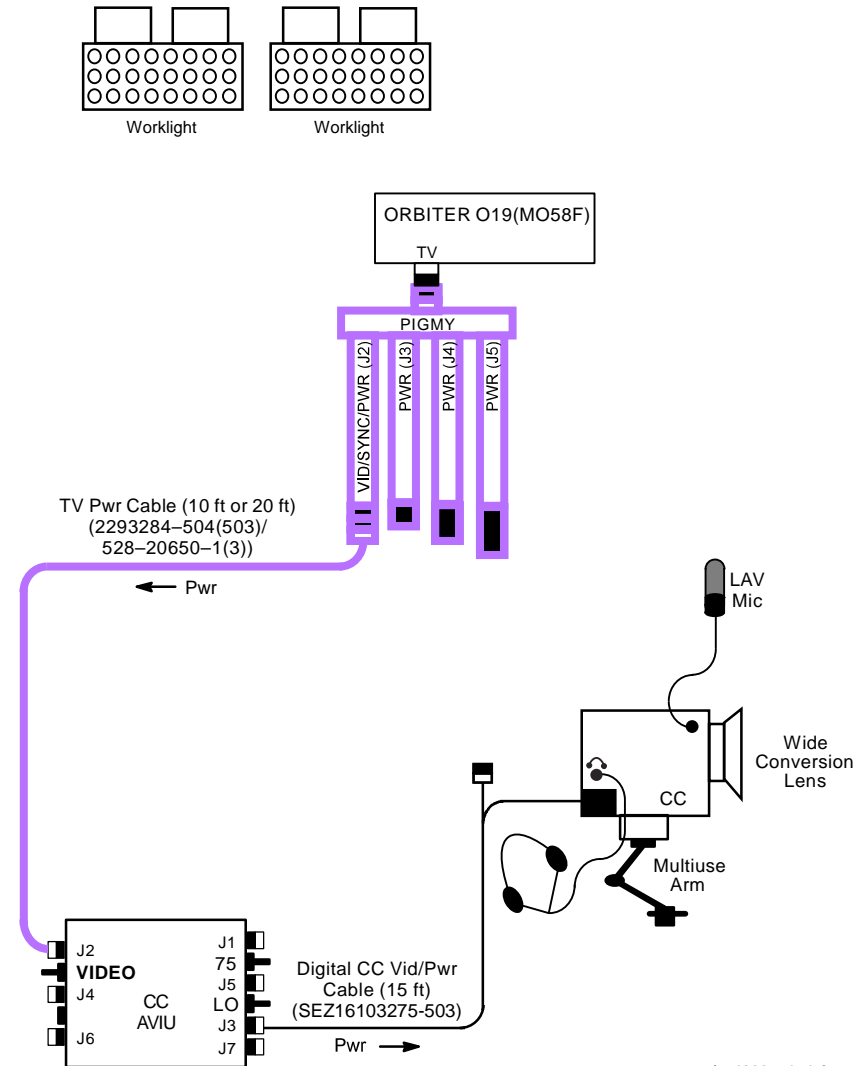

SONY V10

	<u>PAGE</u>
SPECIFICATIONS.....	8-2
NOMENCLATURE.....	8-3
NOMINAL MENU SETTINGS.....	8-5
V10 TO V10 VIA FIREWIRE.....	8-6

## SONY V10

### SONY V10

#### SPECIFICATIONS

TAPE: Mini DVCAM Cassette  
TAPE LENGTH: 40 min  
CD: Color, 5.5 in  
AUDIO: 16 bit at 48 KHz  
PWR: 7.2V Li-ION Batt Pack, 8.4V DC IN  
BATT LIFETIME: ~60 min w/LCD closed  
                  ~30 min w/LCD open  
BODY WEIGHT: 2.00 lb  
BATT WEIGHT: 0.41 lb



# SONY V10 (Continued)

## NOMENCLATURE

- |                               |                                  |                  |
|-------------------------------|----------------------------------|------------------|
| ① REC ORG TC Lamp             | ⑫ REW (rewind) pb                | ⑳ Headphone Jack |
| ② REC ORG TC pb               | ⑬ LCD Screen                     | ㉑ EJECT sw       |
| ③ TC Reset pb                 | ⑭ POWER sw                       | ㉒ Remote Sensor  |
| ④ DISPLAY pb                  | ⑮ MENU pb, Control dial          | ㉓ Power Lamp     |
| ⑤ AUDIO DUB pb                | ⑯ AUDIO Input/Output Jacks (R,L) |                  |
| ⑥ REC (recording) pb and Lamp | ⑰ RFU DC OUT Jack                |                  |
| ⑦ SLOW pb                     | ⑱ VIDEO Input/Output Jack        |                  |
| ⑧ PAUSE pb                    | ㉔ S VIDEO Input/Output Jack      |                  |
| ⑨ PLAY (playback) pb          | ㉕ LCD BRIGHT pb                  |                  |
| ⑩ FF (fast Forward) pb        | ㉖ Speaker                        |                  |
| ⑪ STOP pb                     | ㉗ Volume pb                      |                  |

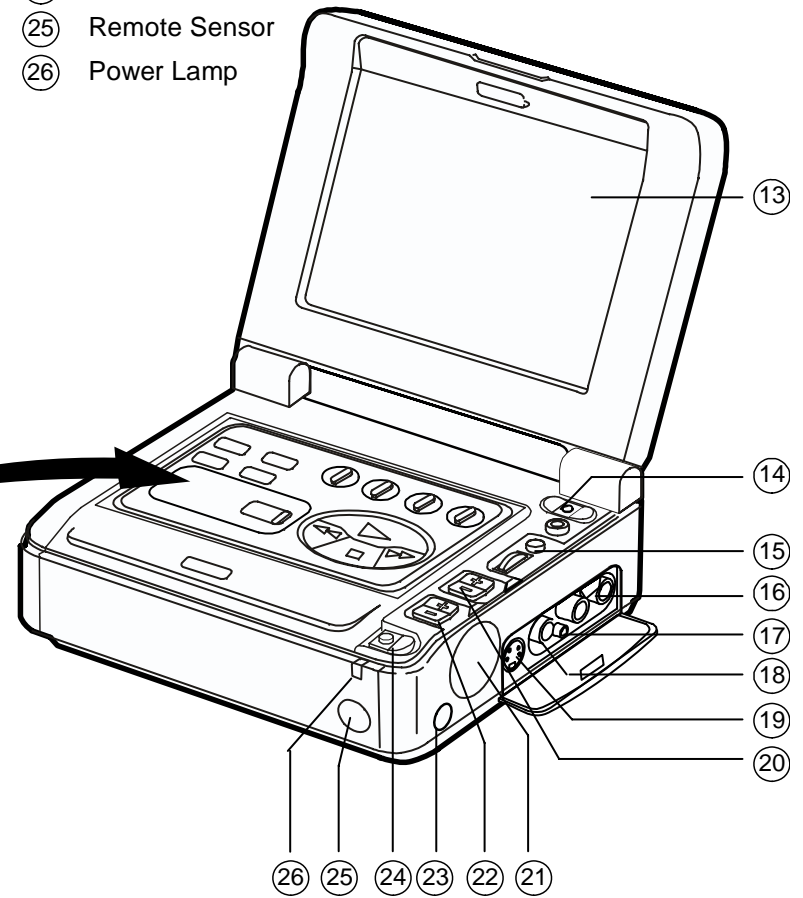
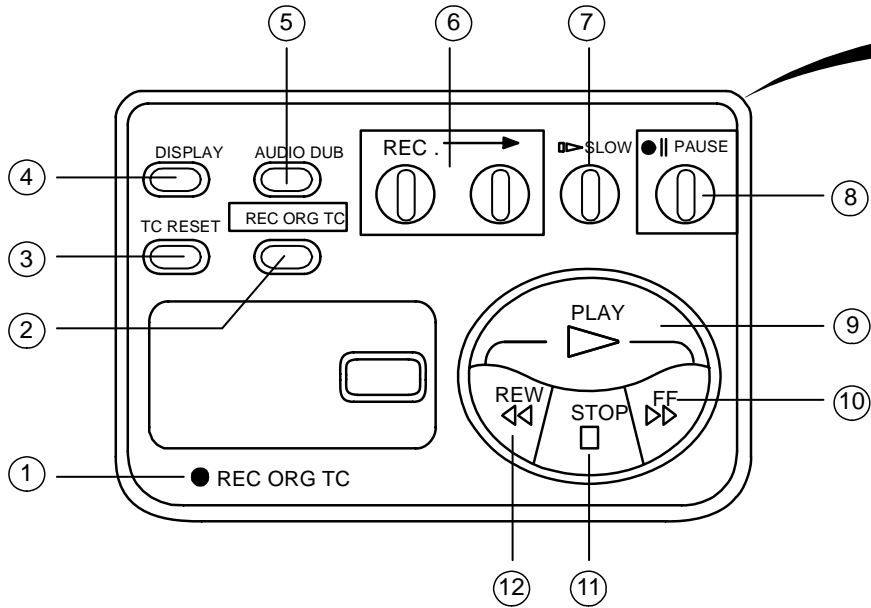

jsc48037\_037.cnv

## SONY V10 (Continued)

### NOMENCLATURE (Concluded)

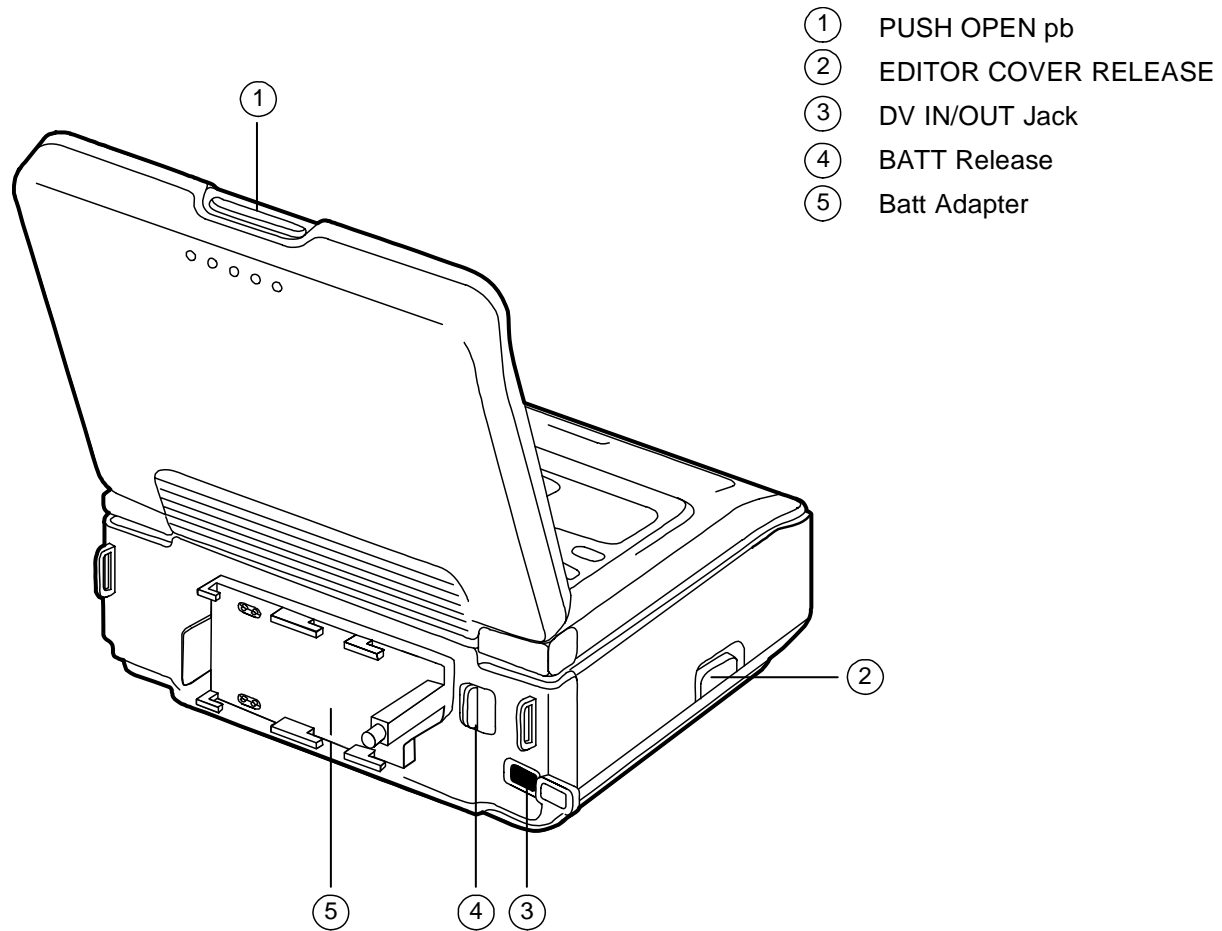

jsc48037\_038.cnv

## SONY V10 (Continued)

### NOMINAL MENU SETTINGS

CMD – VTR4  
HiFi SOUND – STEREO  
AUDIO MODE – FS48K (non-default)  
TIME CODE – DF  
BEEP – ON  
AUDIO MIX – “left” (ST1)  
CM SEARCH – ON  
DATA CODE – DATE/CAM  
LCD COLOR – “center”  
LCD HUE – “center”  
DISPLAY – LCD  
JOG AUDIO – OFF  
CLOCK SET – set to GMT

# SONY V10 (Concluded)

## V10 TO V10 VIA FIREWIRE

Config H/W per dwg at right

- |          |  |
|----------|--|
| AVIU     | SYNC/VIDEO – VIDEO<br>HI-Z/75 – 75<br>PWR SELECT – LO  |
| PLBK V10 | PWR – ON<br>DISPLAY pb – push<br>Install source tape. Protect Tab – Slide (red visible)<br>PLAY pb – push<br>Cue tape to desired take<br>PAUSE pb – push |
| RCD V10  | PWR – ON<br>DISPLAY pb – push<br>Install new tape<br>REC pb – push<br>PAUSE pb – push  |
| PLBK V10 | Perform following for each video segment:<br>PAUSE pb – push (To PLAY)   |
| RCD V10  | PAUSE pb – push (To REC)   |
| PLBK V10 | When EDIT segment complete:<br>PAUSE pb – push (PAUSE)   |
| RCD V10  | PAUSE pb – push (PAUSE)  |

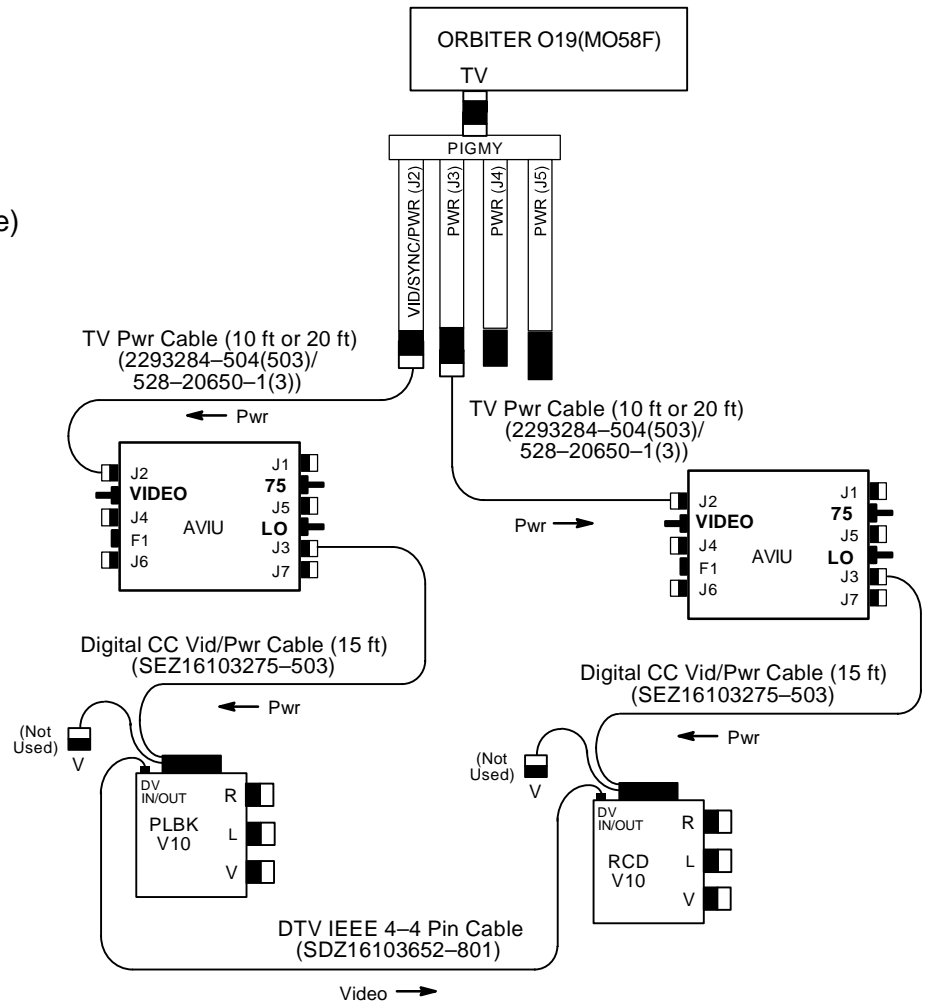

jsc48037\_039r1.cvx

PORTABLE MONITORS

	<u>PAGE</u>
A31p VIDEO CONVERTER.....	9-2
VPU REPEATER.....	9-4

**PORTABLE MONITORS**

**A31p VIDEO CONVERTER**

- A31p
1. √A31p Pwr – ON
  2. Connect A31p Video Adapter to A31p VID IN “”
  3. Connect appropriate hardware from video source to A31p Video Adapter Cable depending on desired video source per table below

Video Source	Hardware (part #)	From	To	Cable Connections
PAYLOAD/DTV	• AVIU-CC Video Cable (15 ft) (SED39122269-301)	• L10A1 VTR OUT	• A31p Video Adapter	• BNC – RCA
Monitor 1(2) (option 1)	• Monitor to AVIU/CM Cable (20 ft) (SED39122074-303) • AVIU (SED33111493-302/303) • AVIU Video Cable Assy (SEZ33114239-301)	• Mon/J3 ----- • AVIU/J5	• AVIU/J4 ----- • A31p Video Adapter	• Circ – Twinax ----- • Unique – RCA
Monitor 1(2) (option 2)	• Monitor to AVIU/CM Cable (20 ft) (SED39122074-303) • AVIU (SED33111493-302/303) • Balanced Video Cable (SED33105778-301) • Bal/Unbal Xfmr (SED39124190-301) • AVIU-CC Video Cable (15 ft) (SED39122269-301)	• Mon/J3 ----- • AVIU/J6 • Balanced Video Cable • Bal/Unbal Xfmr	• AVIU/J4 ----- • Bal/Unbal Xfmr • AVIU-CC Video Cable • A31p Video Adapter	• Circ – Twinax ----- • Twinax – Twinax ----- • BNC – RCA
Monitor 1(2) (option 3)	• Monitor to AVIU/CM Cable (20 ft) (SED39122074-303) • AVIU (SED33111493-302/303) • AVIU-CC Video Cable (15 ft) (SED39122269-301)	• Mon/J3 ----- • AVIU/J7	• AVIU/J4 ----- • A31p Video Adapter	• Circ – Twinax ----- • BNC – RCA
Monitor 1(2) (option 4)	• Monitor to AVIU/CM Cable (20 ft) (SED39122074-303) • Bal/Unbal Xfmr (SED39124190-301) • AVIU-CC Video Cable (15 ft) (SED39122269-301)	• Mon/J3 ----- • Bal/Unbal Xfmr	• Bal/Unbal Xfmr ----- • A31p Video Adapter	• Circ – Twinax ----- • BNC – RCA

## PORTABLE MONITORS (Continued)

### A31p VIDEO CONVERTER (Concluded)

Video Source	Hardware (part #)	From	To	Cable Connections
ISS	<ul style="list-style-type: none"> <li>• VPU Patch Cable (SED39136025-301)</li> <li>• Balanced Video Cable (SED33105778-301)</li> <li>• Bal/Unbal Xfmr (SED39124190-301)</li> <li>• AVIU-CC Video Cable (15 ft) (SED39122269-301)</li> </ul>	<ul style="list-style-type: none"> <li>• VPU FROM ISS</li> <li>• VPU Patch Cable</li> <li>-----</li> <li>• Bal/Unbal Xfmr</li> </ul>	<ul style="list-style-type: none"> <li>• Balanced Video Cable</li> <li>• Bal/Unbal Xfmr</li> <li>-----</li> <li>• A31p Video Adapter</li> </ul>	<ul style="list-style-type: none"> <li>• Plug – Twinax</li> <li>• Twinax – Twinax</li> <li>-----</li> <li>• BNC – RCA</li> </ul>
Spare 1 (SSV)	<ul style="list-style-type: none"> <li>• SSV to PDIP/CIP Cable (SED16103246-301)</li> <li>• Bal/Unbal Xfmr (SED39124190-301)</li> <li>• AVIU-CC Video Cable (15 ft) (SED39122269-301)</li> </ul>	<ul style="list-style-type: none"> <li>• L11A2 PDIP/J107</li> <li>-----</li> <li>• Bal/Unbal Xfmr</li> </ul>	<ul style="list-style-type: none"> <li>• Bal/Unbal Xfmr</li> <li>-----</li> <li>• A31p Video Adapter</li> </ul>	<ul style="list-style-type: none"> <li>• Circ – Twinax</li> <li>-----</li> <li>• BNC – RCA</li> </ul>
WVS	<ul style="list-style-type: none"> <li>• AVIU-CC Video Cable (15 ft) (SED39122269-301)</li> </ul>	<ul style="list-style-type: none"> <li>• R12A2 WIB XCVR1(2) UNBAL</li> </ul>	<ul style="list-style-type: none"> <li>• A31p Video Adapter</li> </ul>	<ul style="list-style-type: none"> <li>• BNC – RCA</li> </ul>
PD100 Camc (option 1)	<ul style="list-style-type: none"> <li>• PD100 A/V Adapter Cable (SEZ16103275-301)</li> <li>• RCA - RCA Cable (SED39122260-314)</li> </ul>	<ul style="list-style-type: none"> <li>• PD100 A/V Port</li> <li>• A/V Adapter</li> </ul>	<ul style="list-style-type: none"> <li>• RCA-RCA Cable (via female adapter)</li> <li>• A31p Video Adapter</li> </ul>	<ul style="list-style-type: none"> <li>• Stereo – RCA</li> <li>• RCA – RCA</li> </ul>
PD100 Camc (option 2)	<ul style="list-style-type: none"> <li>• Y-C Cable (SED33104816-301)</li> </ul>	<ul style="list-style-type: none"> <li>• PD100 S-Video Port</li> </ul>	<ul style="list-style-type: none"> <li>• A31p Video In Port (No A31p Video Adapter)</li> </ul>	<ul style="list-style-type: none"> <li>• S-Video – S-Video</li> </ul>

4. Config H/W per dwg at right
5. Double-click Shuttle Apps > 'NASA Video Overlay'
6. ✓ 'NASA Video Overlay' window displayed
7. Sel 'Local Full Screen'  
Press 'ESC' or 'W' key to minimize display as reqd

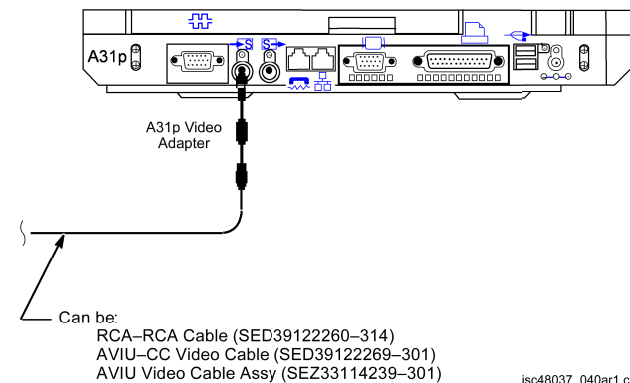

jsc48037\_040ar1.cvx

# PORTABLE MONITORS (Concluded)

## VPU REPEATER

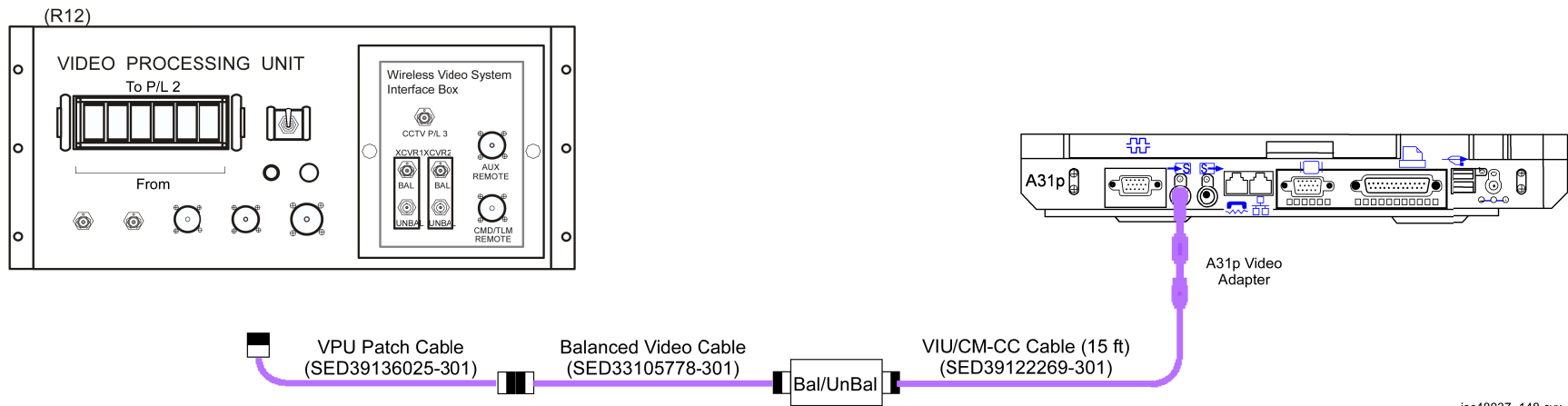

joc48037\_148.cvx



CCTV

	<u>PAGE</u>
SPECIFICATIONS.....	10-2
LENS DATA.....	10-3
ILLUMINATOR DATA.....	10-3
CCTV SYSTEM OVERVIEW.....	10-4
VPU/WIB VIDEO ROUTING OVERVIEW .....	10-5
AVIU OVERVIEW.....	10-6
TVCU.....	10-7
PHOTO FLOODLIGHT .....	10-8
MALS.....	10-9
10.1 NO MONITOR PICTURE/MENU .....	10-9
10.2 NO CAMR VIDEO.....	10-16
10.3 NO VTR PLAYBACK VIDEO .....	10-18
10.4 NO CAMCORDER VIDEO ON COLOR TV MONITOR .....	10-20
10.5 RMS TV cb OPENS .....	10-24

CCTV

**SPECIFICATIONS**

CTVC (SOLID STATE)

EFFECTIVE IMAGE SIZE: 6.54mm X 8.62mm  
PWR: 43.3W at 32V (all motors on)  
ZOOM SPEED: End-to-End 8 sec  
FOCUS SPEED: End-to-End 22 sec  
IRIS: Auto(Manual) Close ~7 sec  
WEIGHT: 18.9 lb  
DIMENSION: 17" (L) x 6.4" (W) x 6.3" (H)

ITVC

EFFECTIVE IMAGE SIZE: 6.54mm X 8.62mm  
PWR: 33.6W at 32V  
ZOOM SPEED: End-to-End 8 sec  
FOCUS SPEED: End-to-End 22 sec  
IRIS: Auto close ~6 sec  
WEIGHT: 17 lb  
DIMENSION: 19.6" (L) (Includes 3.2" Lens) x 6.4" (W) x 6.3" (H)

## CCTV (Continued)

### LENS DATA

Lens/Focal Length		Aperture Range	Zoom Ratio	Minimum Focus Distance (ft)	Approximate Field of View (FOV)	
					Horizontal	Vertical
CTVC (COLOR)*	5.5mm-47mm	f/1.7 to f/16 (T2-T360)	8:1	1.0	75°-10°	61°-8°
ITVC (B/W)*	8.5mm-127mm	f/1.7 to f/16 (T2-T360)	15:1	3.0	53°-4°	41°-3°

### ILLUMINATOR DATA

Color	LEDs	LED Deg Angles	Camr Type	Locations	Modes	Control
Red	120	8°/22°/8° *	ITVC	Bulkhead, Elbow, Keel	ON/OFF	cb CAMR HTR
	120	22°	ITVC	Bulkhead, Elbow, Keel	ON/OFF	cb CAMR HTR
White	40	44°	CTVC	Wrist	ON/OFF	cb CAMR HTR
	180	20°	CTVC/ITVC	Bulkhead, Elbow, Keel	ON/OFF	cb PAN/TILT HTR
	156	29°	Videospection	Keel	156 LED/84 LED/30 LED/OFF	SSP/CAMR HTR sw

\*Three rings of LEDs:  
 Inner,outer rings – 8° LEDs  
 Middle ring – 22° LEDs

# CCTV (Continued)

## CCTV SYSTEM OVERVIEW

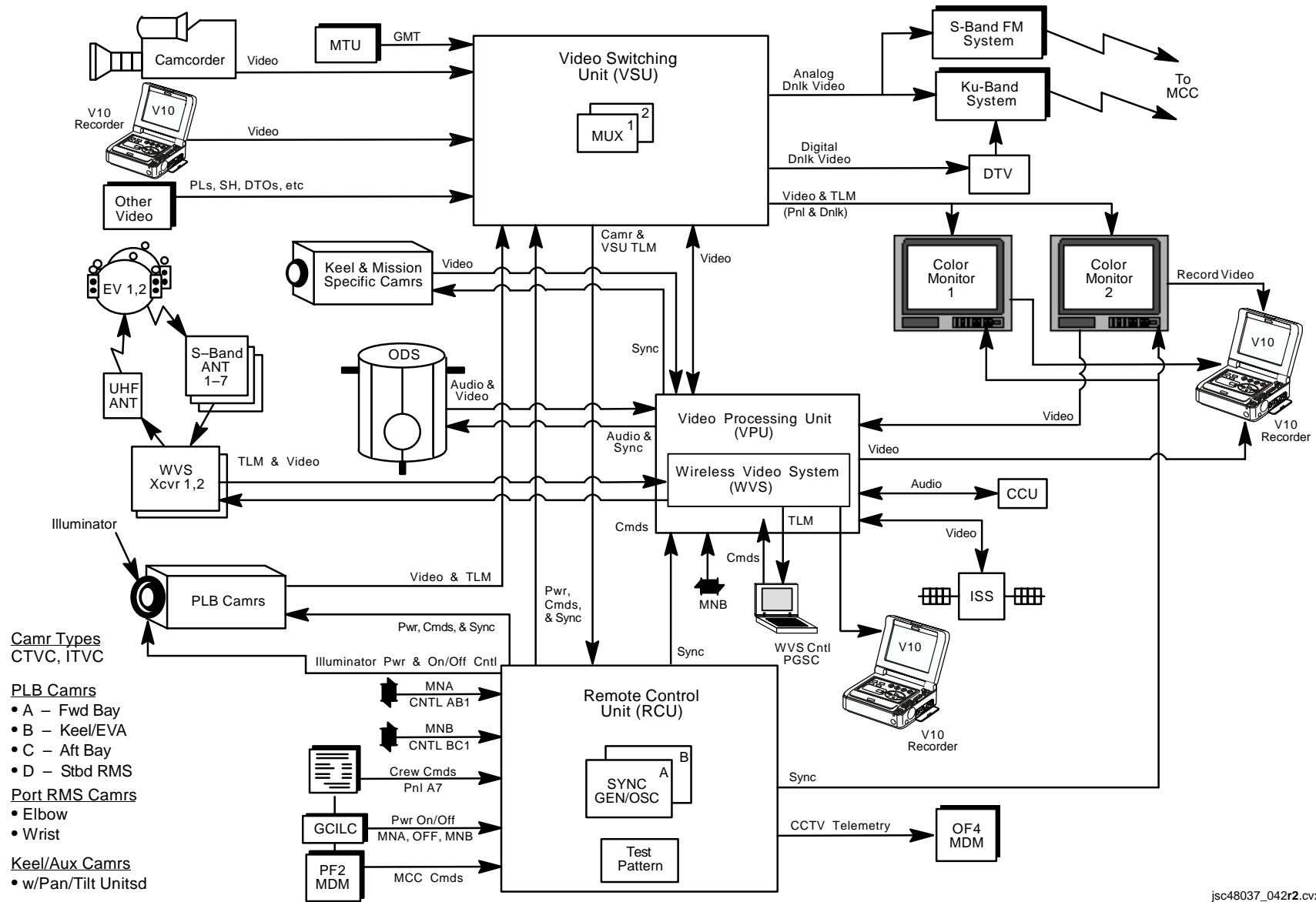

jsc48037\_042r2.cvx

# CCTV (Continued)

## VPU/WIB VIDEO ROUTING OVERVIEW

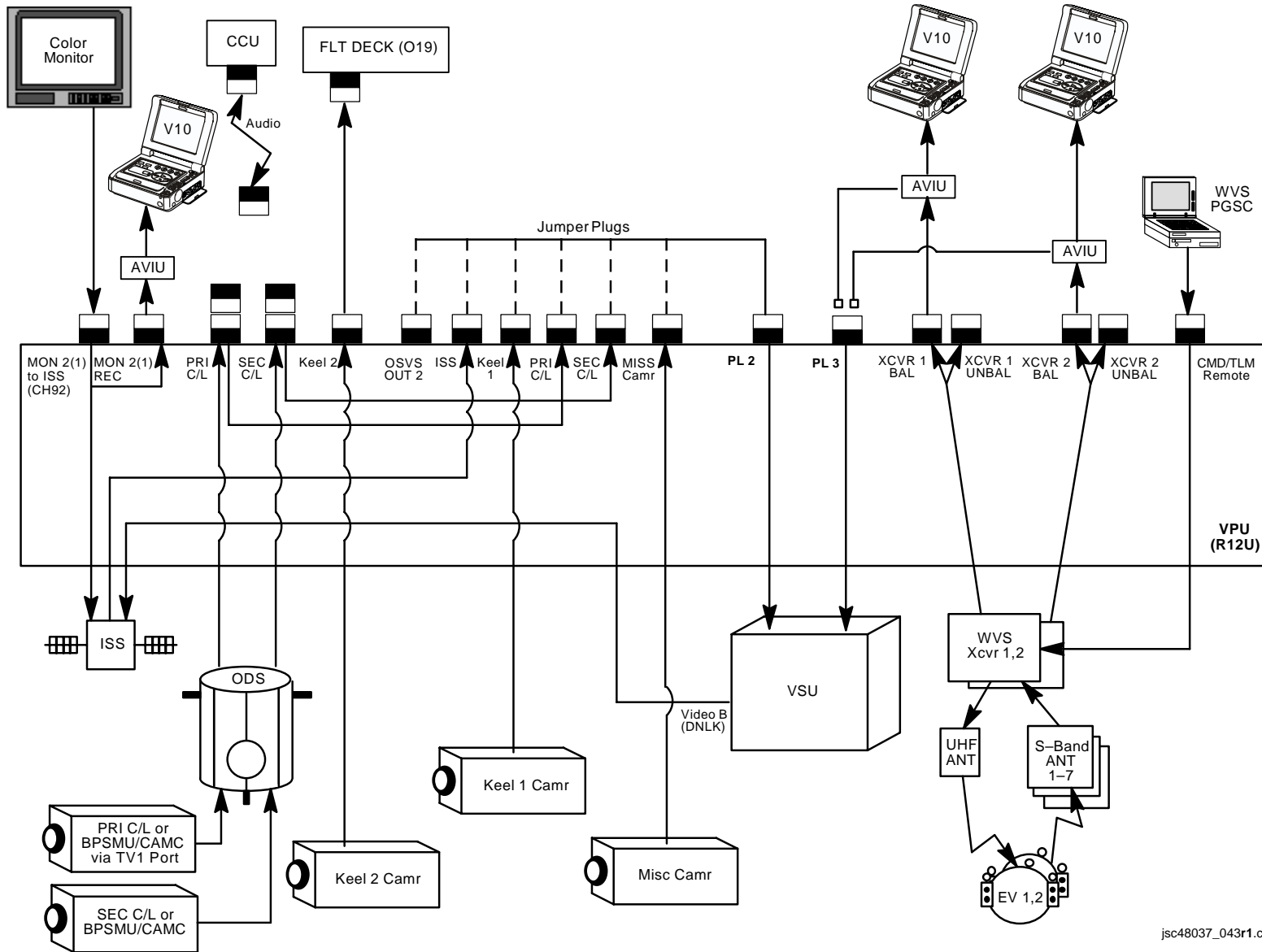

jsc48037\_043r1.cvx

# CCTV (Continued)

## AVIU OVERVIEW

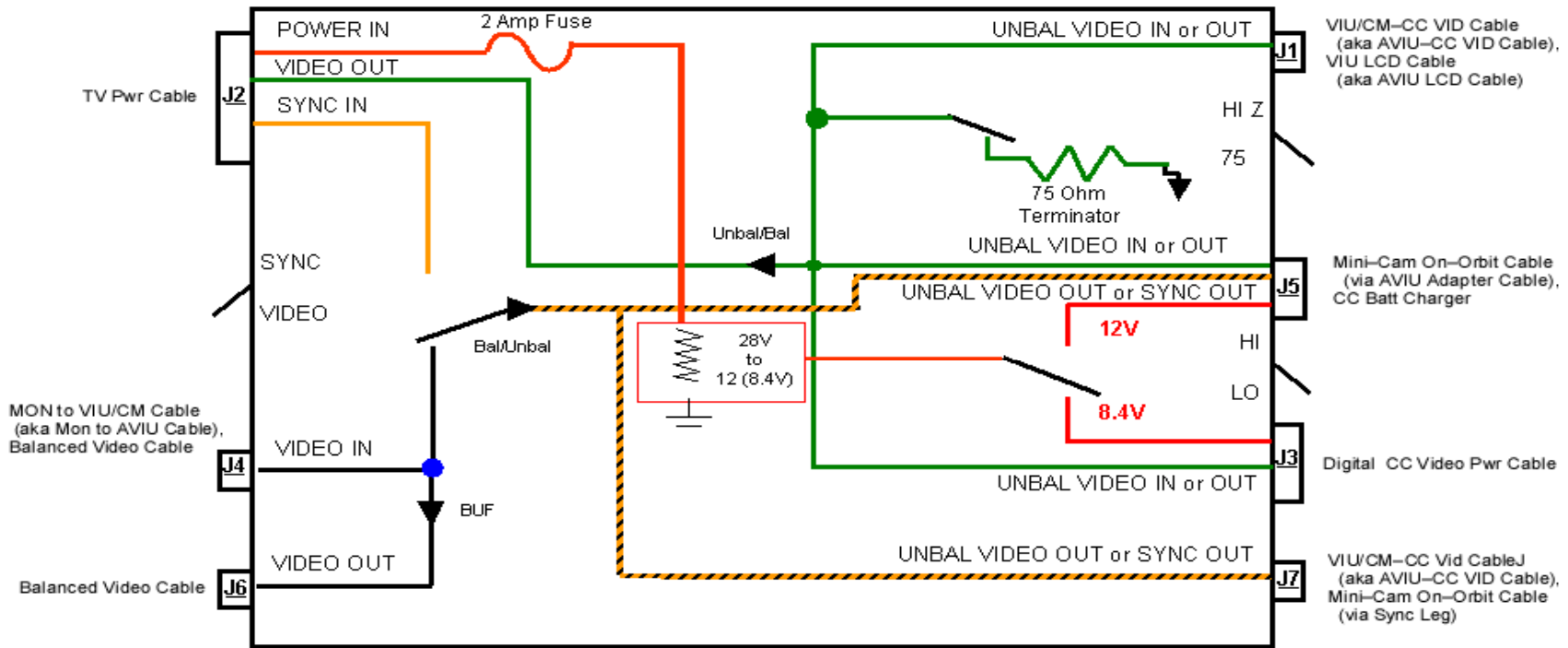

isc48037\_044r1.cvx

### J1

- Unbalanced Video Input(Output)

### J2

- 28V Input
- Sync Input
- Balanced Video Output

### J3

- 8.4V Power Output if HI/LO sw – LO
- Unbalanced Video Input(Output)

### J4

- Balanced Video Input

### J5

- 12V Power Output if HI/LO sw – HI
- Unbalanced Video Input(Output)
- Unbalanced Video Output (of J4 Balanced Input) if SYNC/VIDEO sw – VIDEO
- Sync Output if SYNC/VIDEO sw – SYNC

### J6

- Balanced Video Signal Output (turnaround from J4)

### J7

- Unbalanced Video Output (of J4 Balanced Input) if SYNC/VIDEO sw – VIDEO
- Sync Output if SYNC/VIDEO sw – SYNC

### SYNC/VIDEO sw

- VIDEO – Unbalanced Video Output to J5,J7 from J4 Input
- SYNC – Sync Output to J5(J7) from J2 input

### HI-Z/75 sw

- 75 – For nominal video output at J1
- HI-Z – For video output at J1 to a terminal source (i.e., PGSC, PD100, or V10)

### HI/LO sw

- HI – 12V output at J5
- LO – 8.4V output at J3

CCTV (Continued)  
TVCU

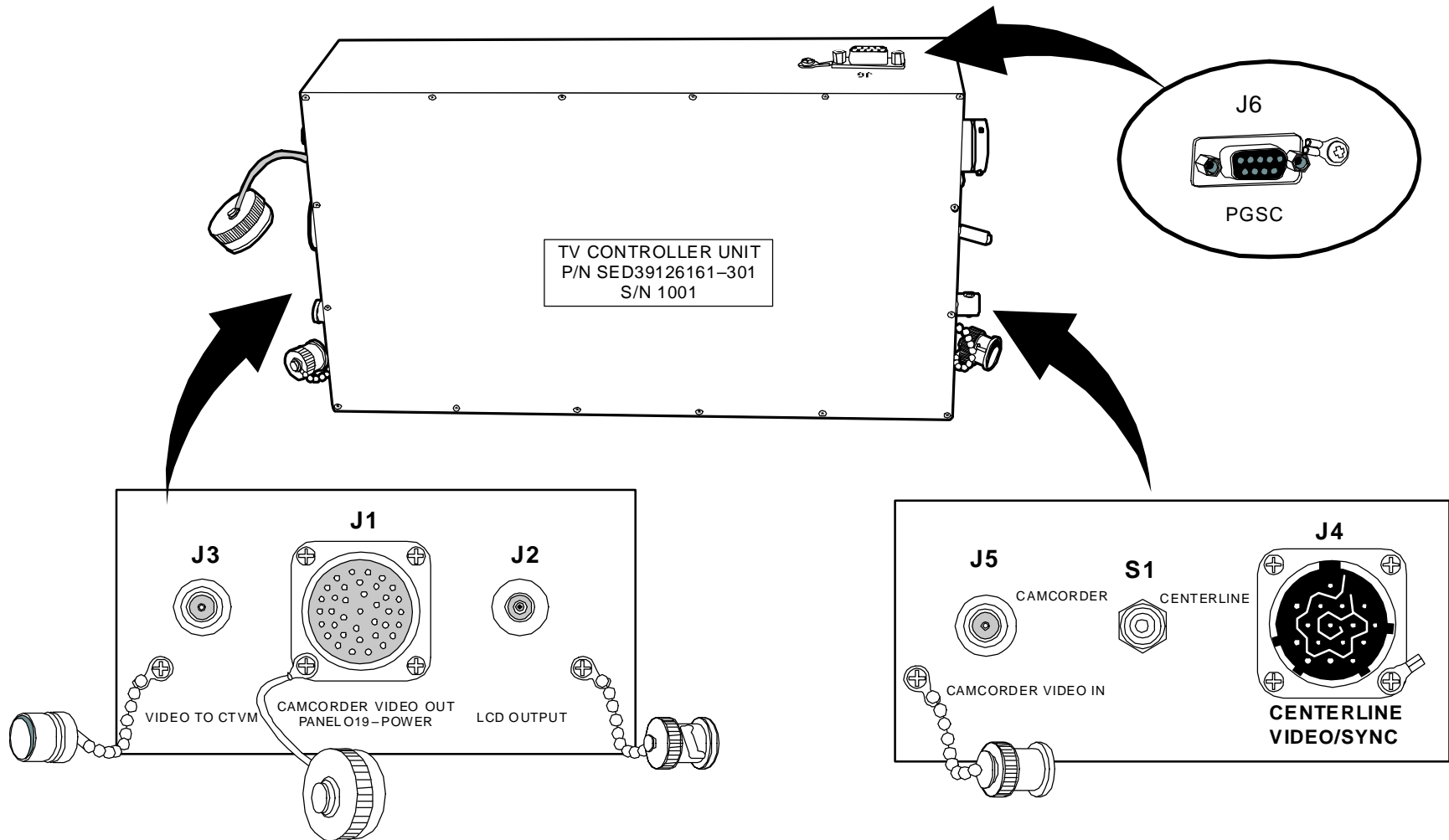

jsc48037\_045.cnv

**CCTV (Continued)**  
**PHOTO FLOODLIGHT**

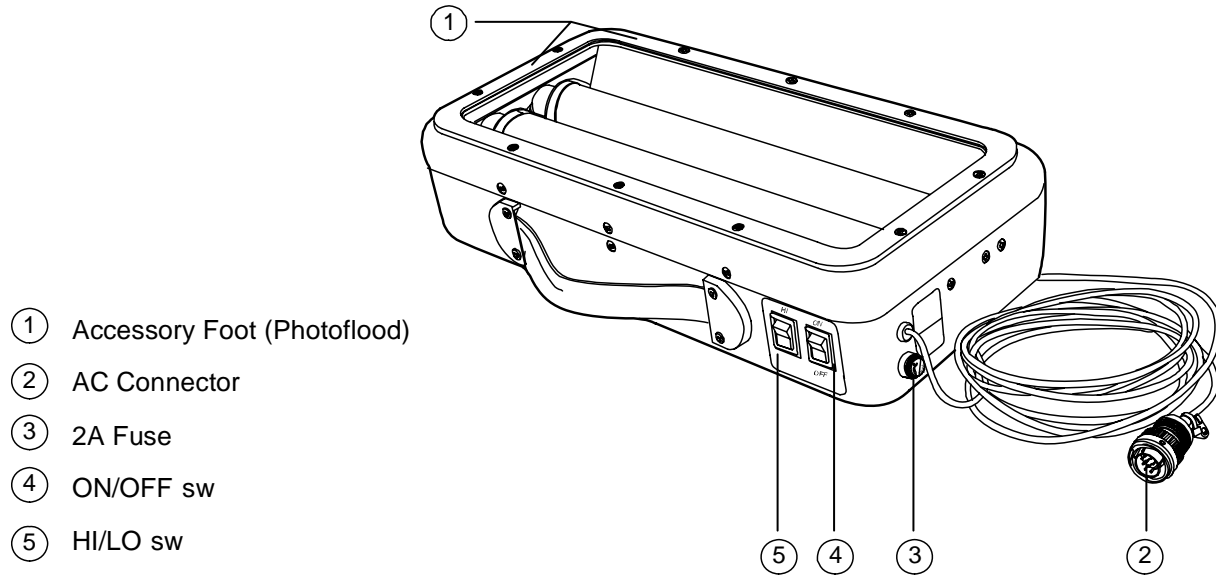

- ① Accessory Foot (Photoflood)
- ② AC Connector
- ③ 2A Fuse
- ④ ON/OFF sw
- ⑤ HI/LO sw

jsc48037\_047.cnv



**CCTV**

**10.1 NO MONITOR PICTURE/MENU**

No Picture on Monitor 1(2)

**Nominal Config:**

- (R14:D)  
 cb MNA TV C AFT  
 BAY CAMR/PAN-TILT - cl  
 CAMR HTR - cl  
 PAN-TILT HTR - cl  
 cb MNA TV CONTR UNIT - cl  
 cb MNA TV MON 1 - cl  
 cb MNB TV A FWD BAY CAMR/PAN-TILT - cl  
 CAMR HTR - cl  
 PAN-TILT HTR - cl  
 cb MNB TV CONTR UNIT - cl  
 cb MNB TV MON 2 - cl  
 cb MNC TV B KEEL/EVA CAMR/PAN-TILT - cl  
 CAMR HTR - cl  
 PAN-TILT HTR - cl  
 cb MNC TV CAB - cl  
 (R14:E)  
 cb MNA D STBD RMS TV CAMR/PAN-TILT - cl  
 CMR HTR - cl  
 PAN-TILT HTR - cl  
 cb MNB RMS PORT RMS TV CAMR/PAN-TILT - cl  
 CAMR HTR - cl  
 PAN-TILT HTR - cl  
 (A7U)  
 TV PWR CNTL - CMD  
 TV PWR CONTR UNIT - MNA(MNB)  
 TV SYNC - NORM  
 TV DNLK - ENA  
 (A3)  
 MON 1(2)  
 SOURCE - as reqd  
 SYNC - INT  
 PWR - ON  
 MODE - AUTO  
 GUNS - R,G,B - ON

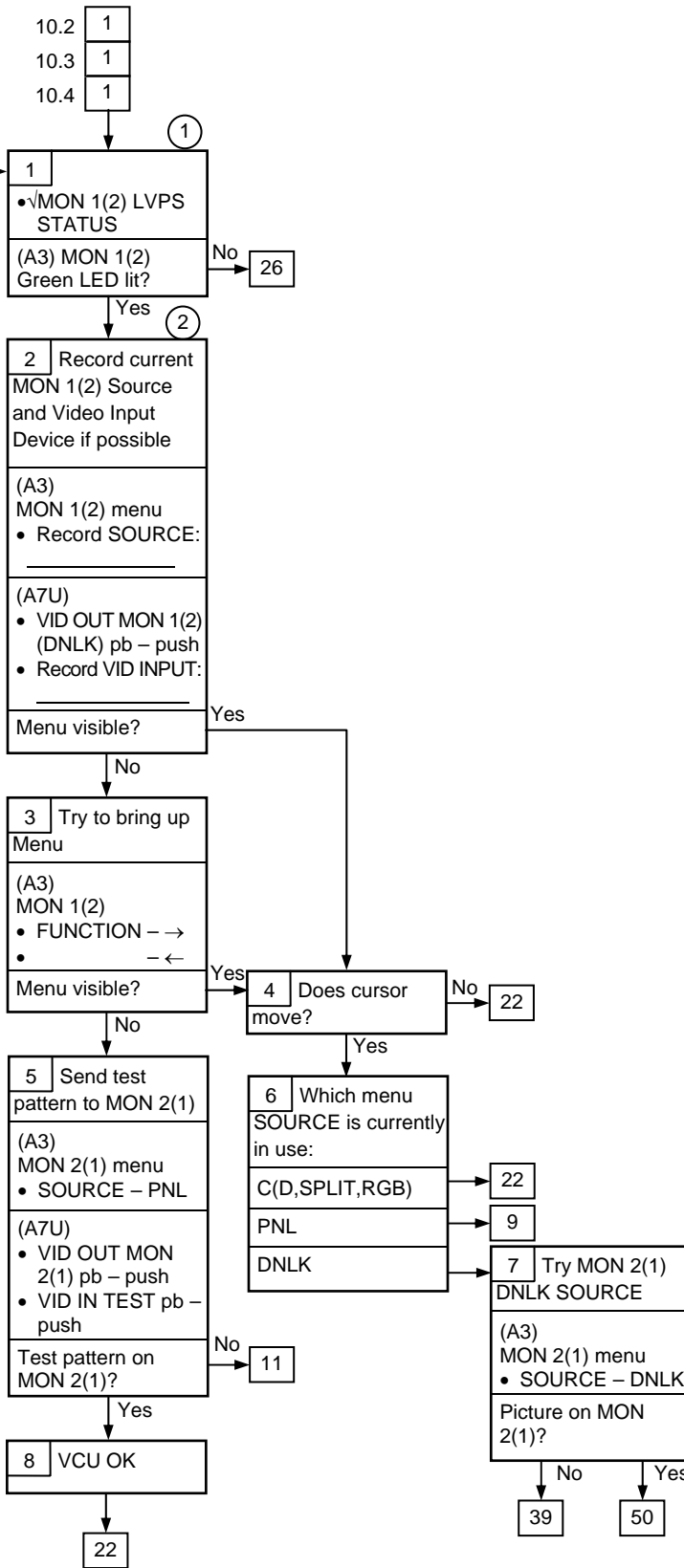

- ①  
 LVPS = low voltage pwr supply
- ②  
 Current SOURCE and INPUT recorded here will be used in subsequent mal blocks

**CCTV 10.1 (Cont)**

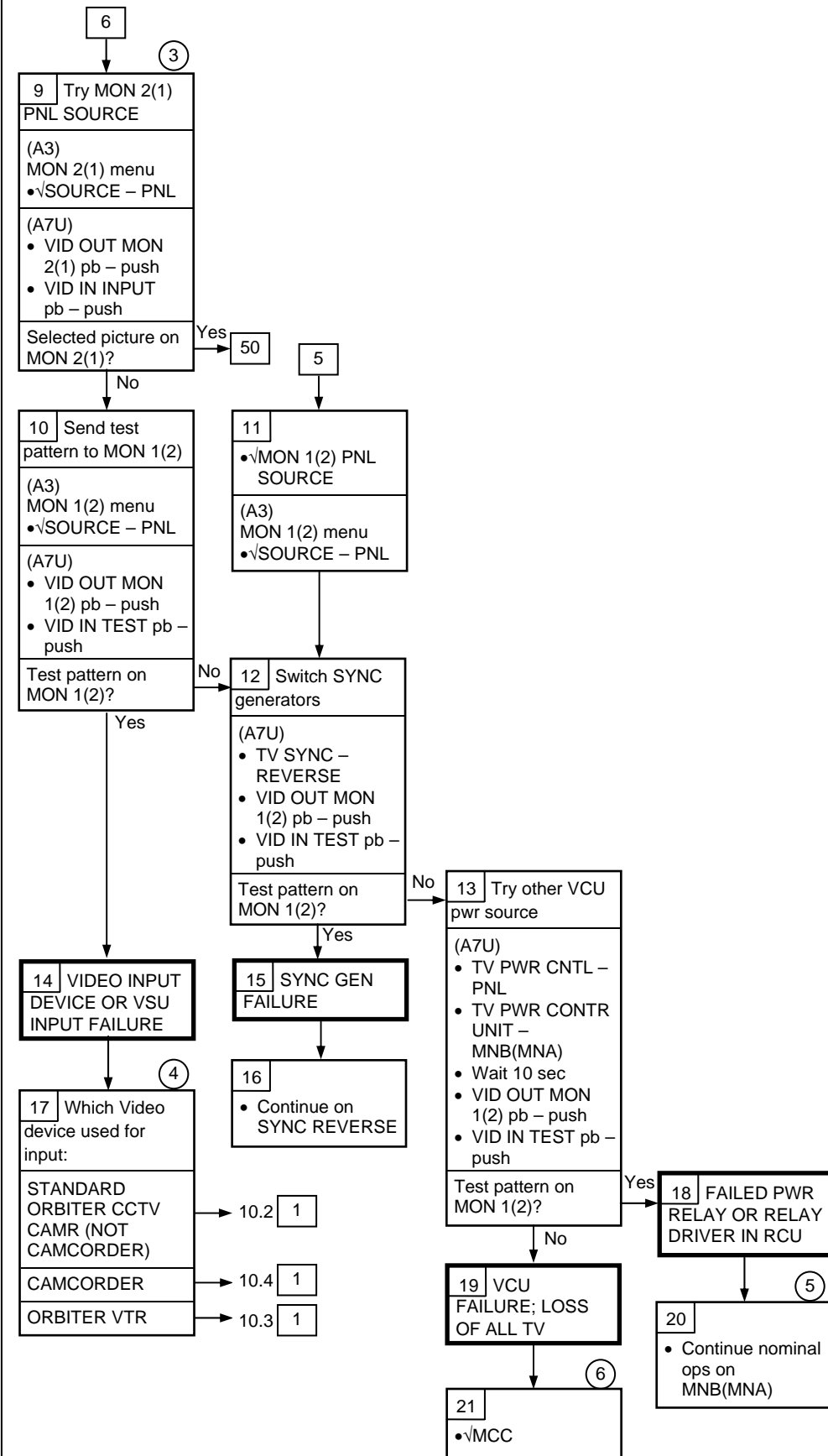

③ INPUT used here was recorded in block 2

④ Video Input Device is the device connected to INPUT which was recorded in block 2

⑤ All TV config in VCU will be lost. All camrs must be pwr'd up and reselected

⑥ Standalone MON 1(2) ops may be possible on inputs C,D, or RGB if connected and also if input SOURCE generates its own sync

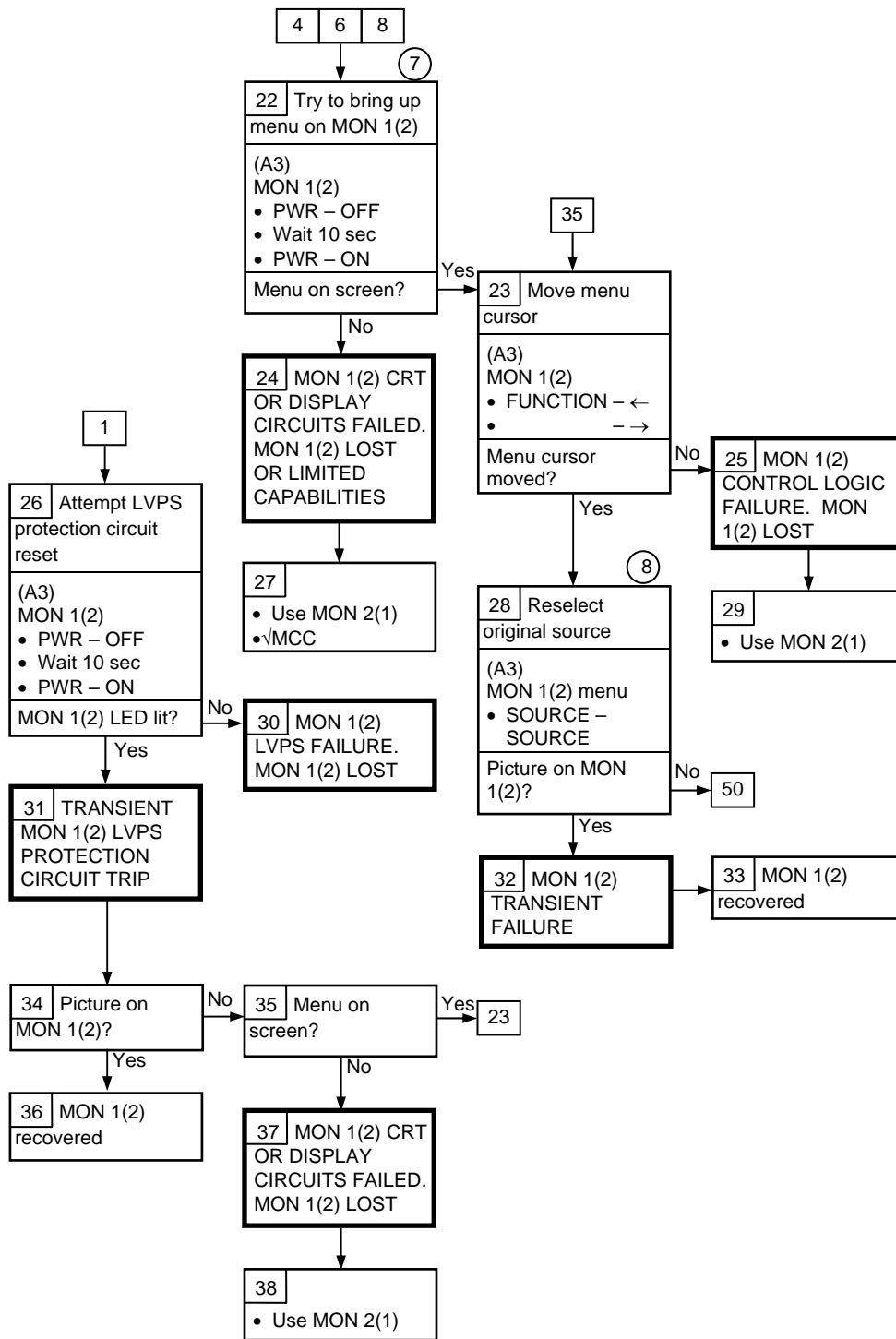

7  
Brightness and contrast controls may need to be adjusted to see menu

8  
SOURCE is the source recorded in block 2

**CCTV 10.1 (Cont)**

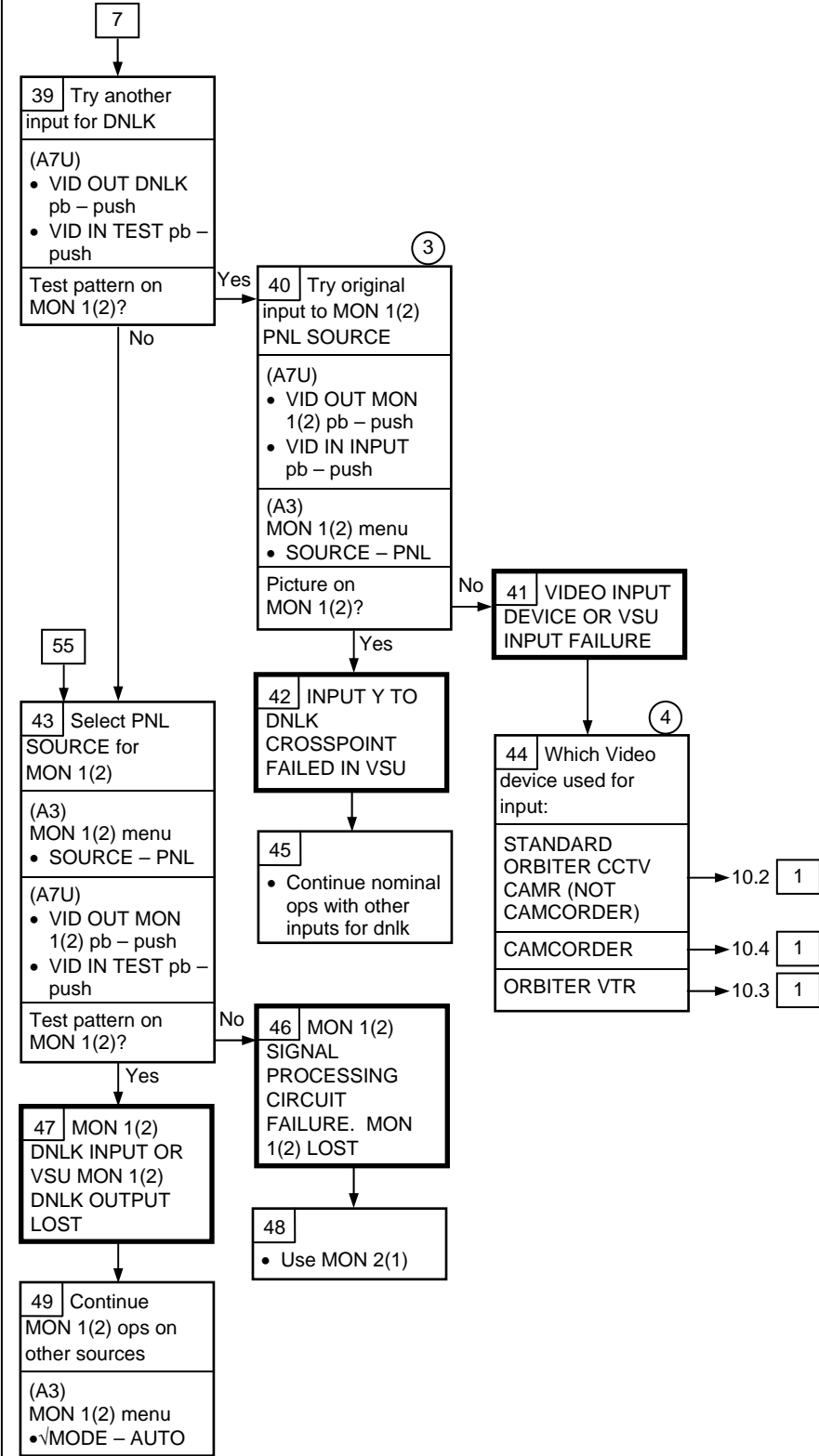

③ INPUT used here was recorded in block 2

④ Video Input Device is the device connected to INPUT which was recorded in block 2

**CCTV 10.1 (Cont)**

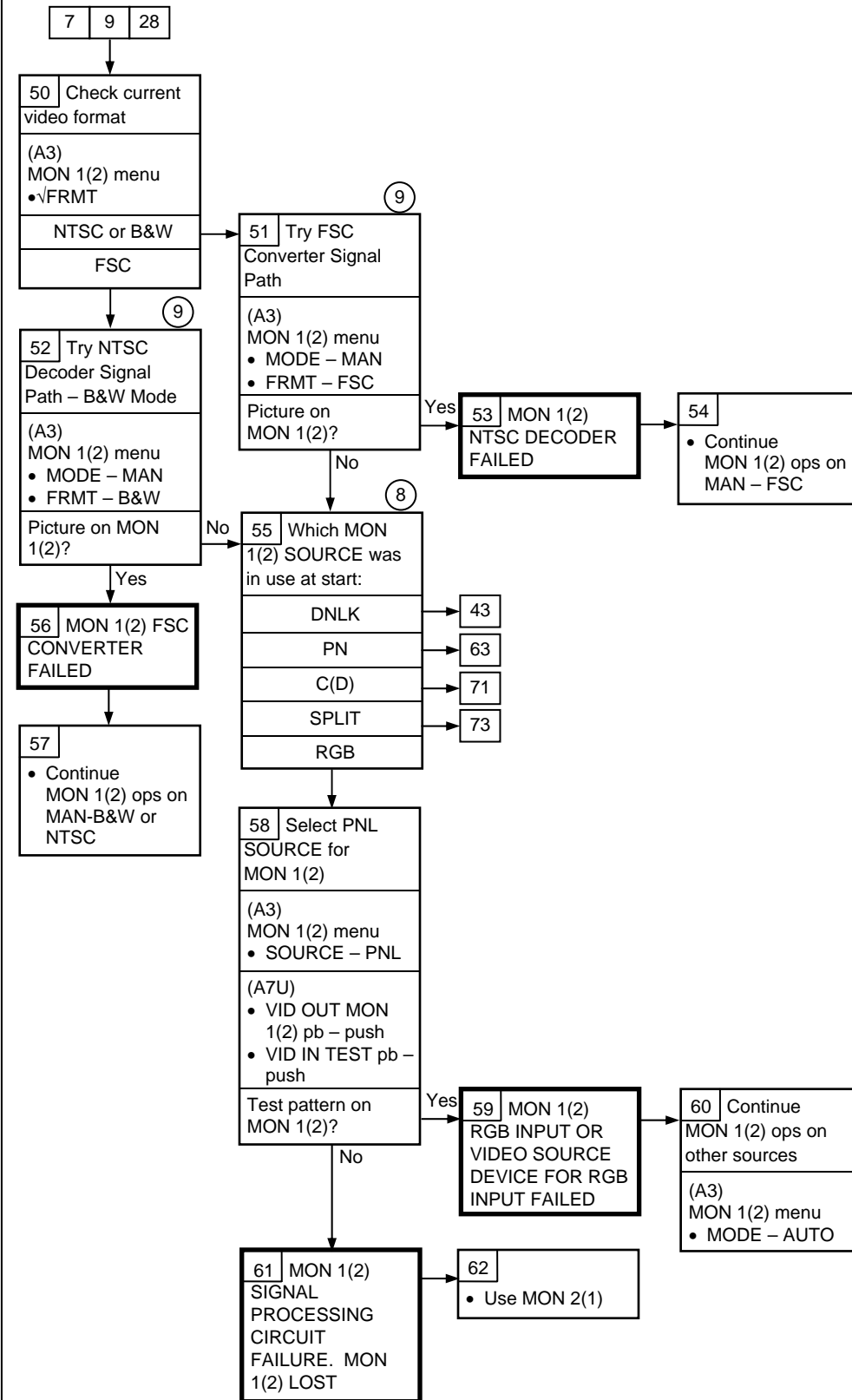

8 SOURCE is the source recorded in block 2

9 Picture will be B&W with possible flicker

**CCTV 10.1 (Cont)**

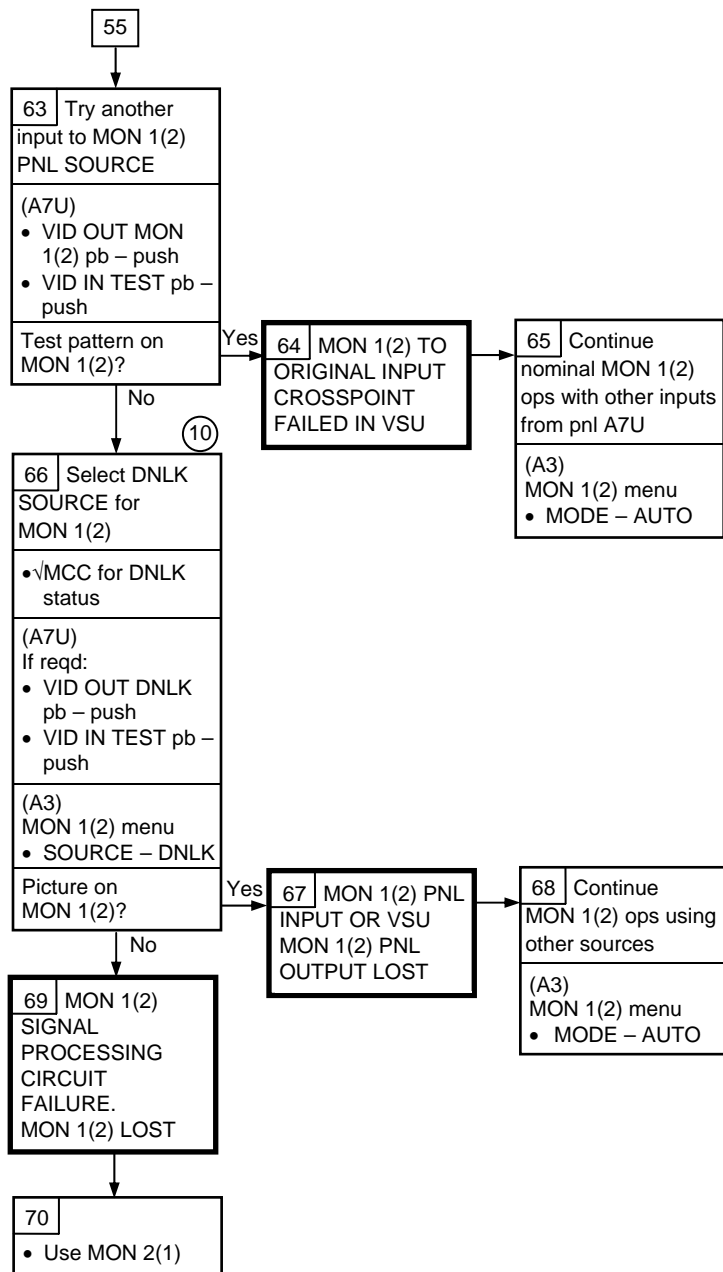

⑩  
If DNLK in progress, selecting test pattern to DNLK not reqd. MCC will advise on DNLK status

**CCTV**

**10.1 (Cont)**

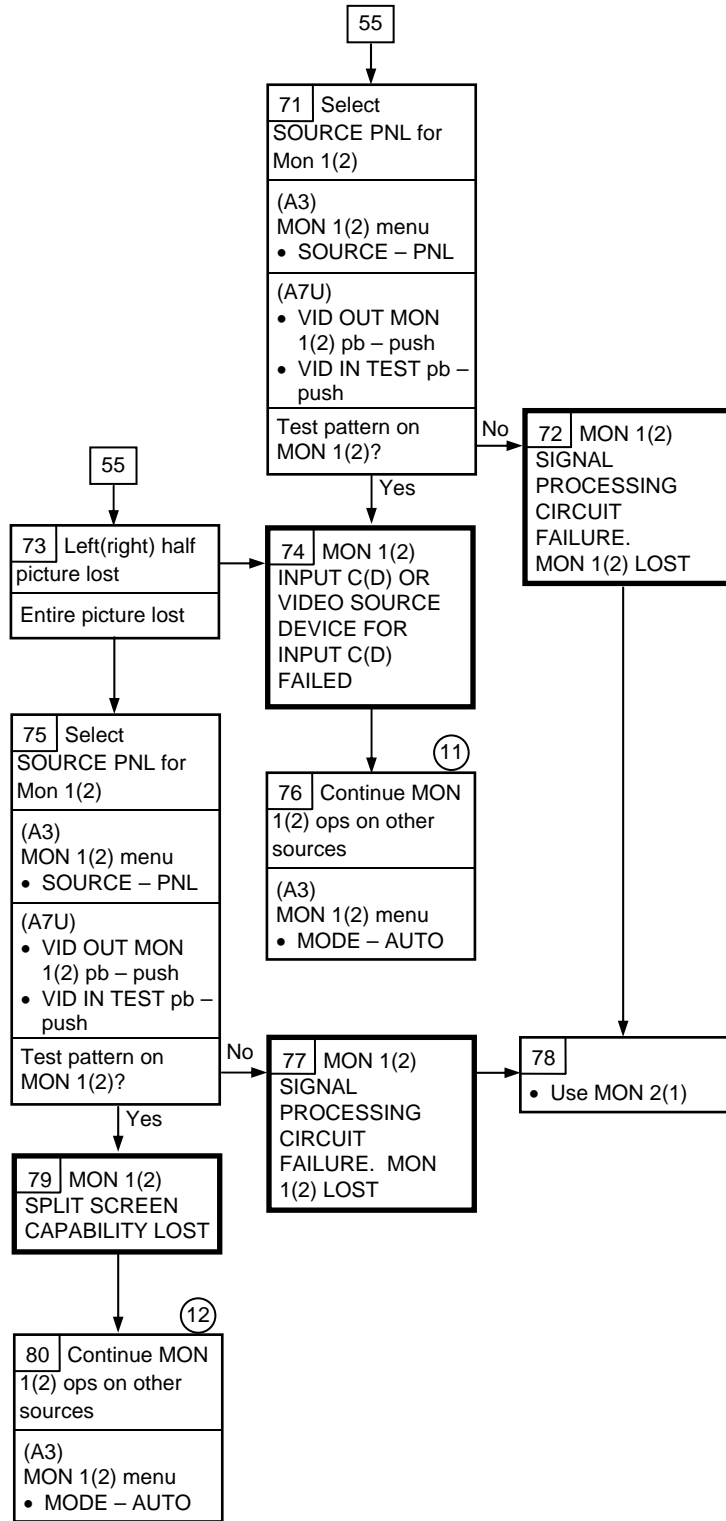

(11) Recovery of video source device may be possible

(12) Inputs C,D may be useable without SPLIT

**CCTV**

**10.2 NO CAMR VIDEO**

No Camr Video

**Nominal Config:**

(R14:D)  
 cb MNA TV C AFT  
 BAY CAMR/PAN-TILT - cl  
 CAMR HTR - cl  
 PAN-TILT HTR - cl

cb MNA TV CONTR UNIT - cl

cb MNA TV MON 1 - cl

cb MNB TV A FWD BAY CAMR/PAN-TILT - cl  
 CAMR HTR - cl  
 PAN-TILT HTR - cl

cb MNB TV CONTR UNIT - cl

cb MNB TV MON 2 - cl

cb MNC TV B KEEL/EVA CAMR/PAN-TILT - cl  
 CAMR HTR - cl  
 PAN-TILT HTR - cl

cb MNC TV CAB - cl

(R14:E)  
 cb MNA D STBD RMS TV CAMR/PAN-TILT - cl  
 CMR HTR - cl  
 PAN-TILT HTR - cl

cb MNB RMS PORT RMS TV CAMR/PAN-TILT - cl  
 CAMR HTR - cl  
 PAN-TILT HTR - cl

(A7U)  
 TV PWR CNTL - CMD  
 TV PWR CONTR UNIT - MNA(MNB)  
 TV SYNC - NORM  
 TV DNK - ENA

(A3)  
 MON 1(2)  
 SOURCE - as reqd  
 SYNC - INT  
 PWR - ON  
 MODE - AUTO  
 GUNS - R,G,B - ON

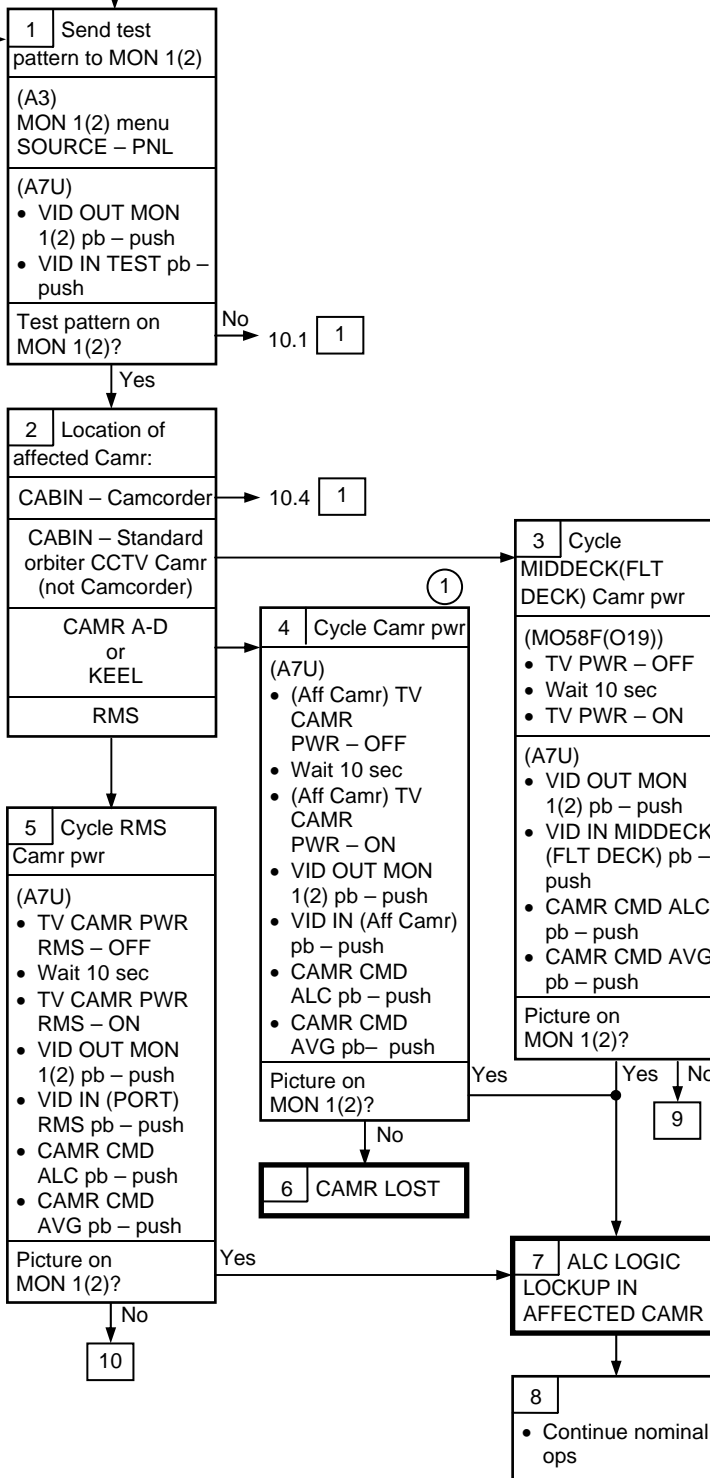
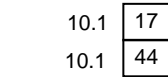

① KEEL Camr pwr control and KEEL Camr Video inputs are mission specific



**CCTV 10.2 (Cont)**

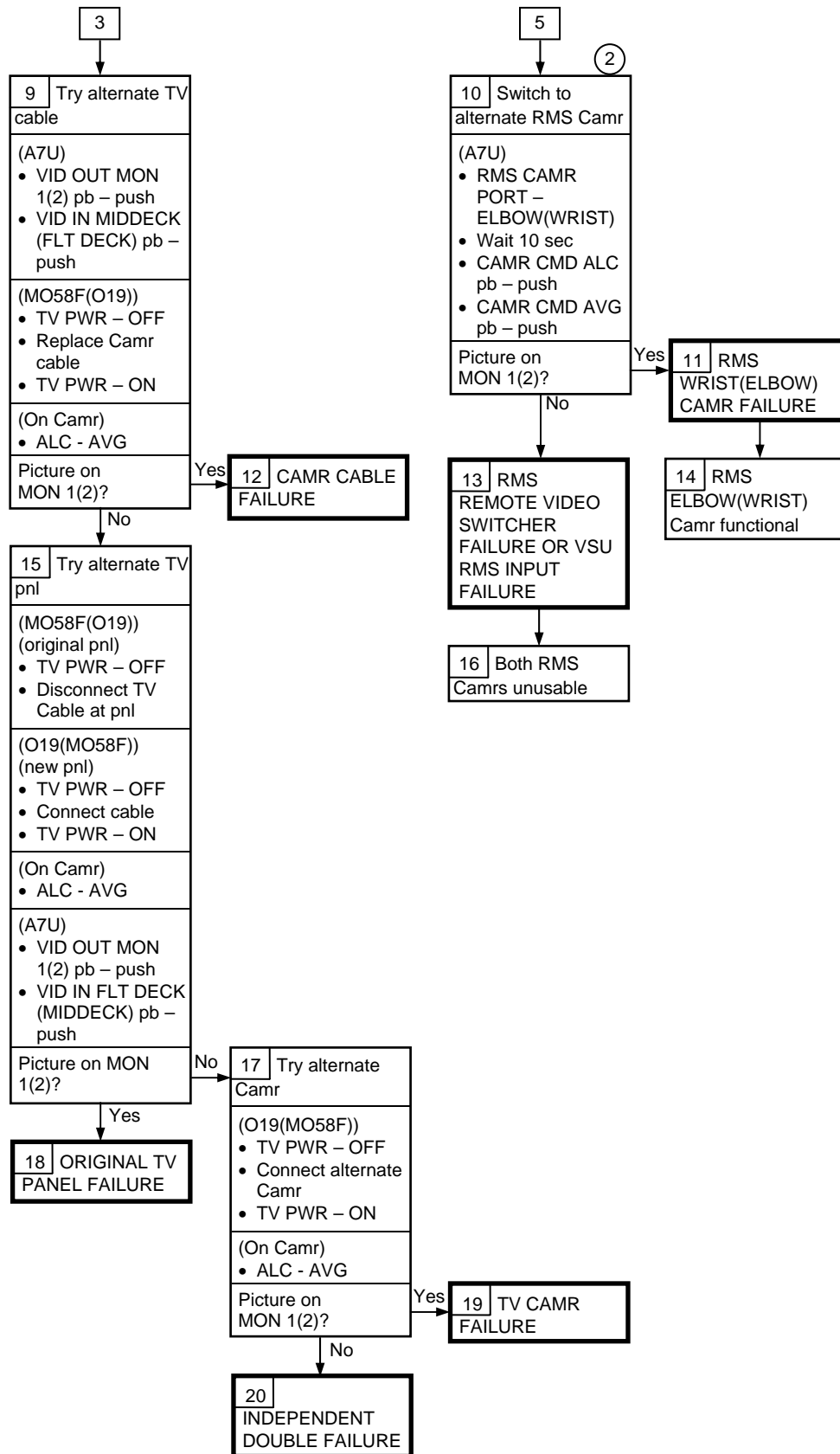

②  
If currently selected to WRIST(ELBOW) then select ELBOW(WRIST)

**CCTV**

**10.3 NO VTR PLAYBACK VIDEO**

No VTR Playback Video

**Nominal Config:**

(R14:D)  
 cb MNA TV CONTR UNIT – cl  
 cb MNA TV MON 1 – cl  
 cb MNB TV CONTR UNIT – cl  
 cb MNB TV MON 2 – cl  
 cb MNC TV CAB – cl

(A7U)  
 TV PWR CNTL – CMD  
 TV PWR CONTR UNIT – MNA(MNB)  
 TV SYNC – NORM  
 TV DNLK – ENA

(A3)  
 MON 1(2)  
 SOURCE – as reqd  
 SYNC – INT  
 PWR – ON  
 MODE – AUTO  
 GUNS – R,G,B – ON

(V10)  
 PWR – ON

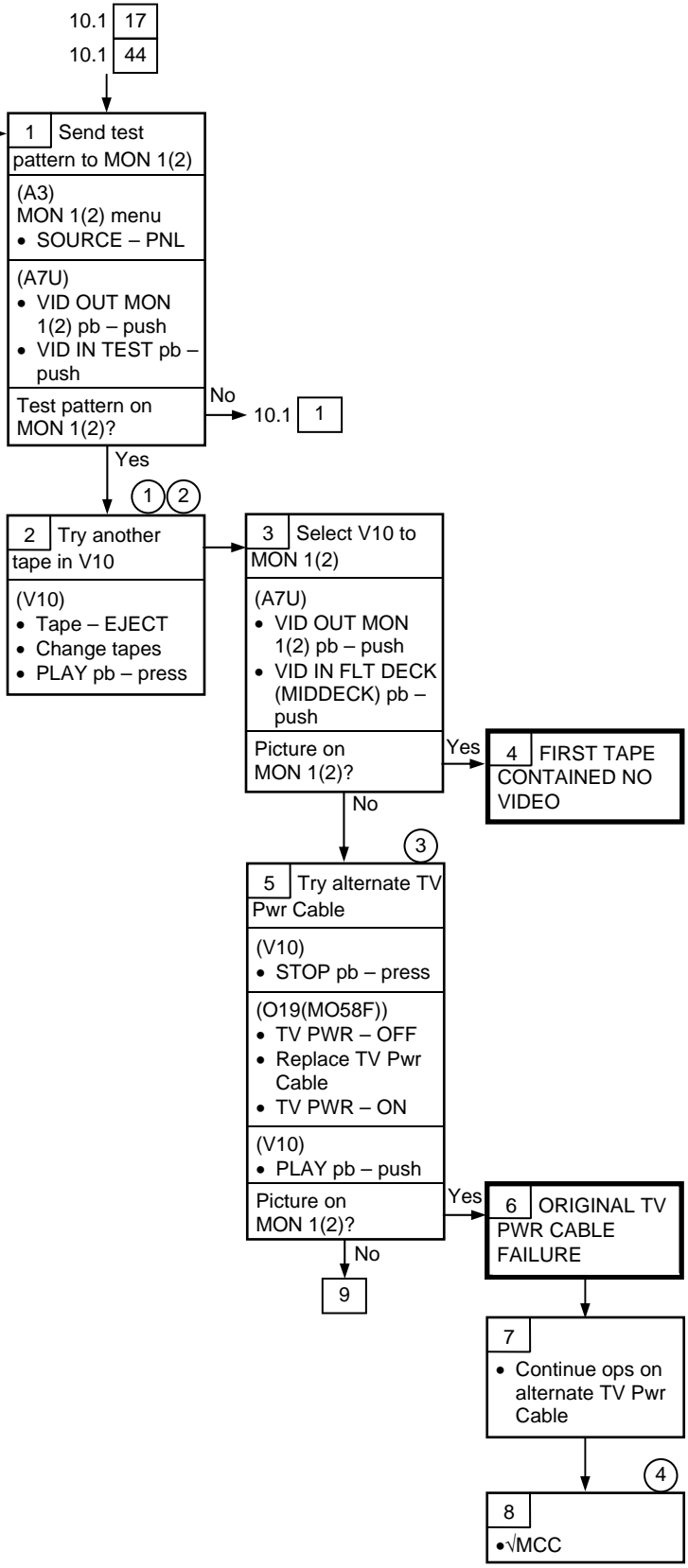

- ① Replacement tape should have good video recorded on it
- ② V10 requires dump thru pnl O19(MO58F)
- ③ √MCC if alternate equip avail
- ④ IFM for AVIU(cables) may be possible

**CCTV 10.3 (Cont)**

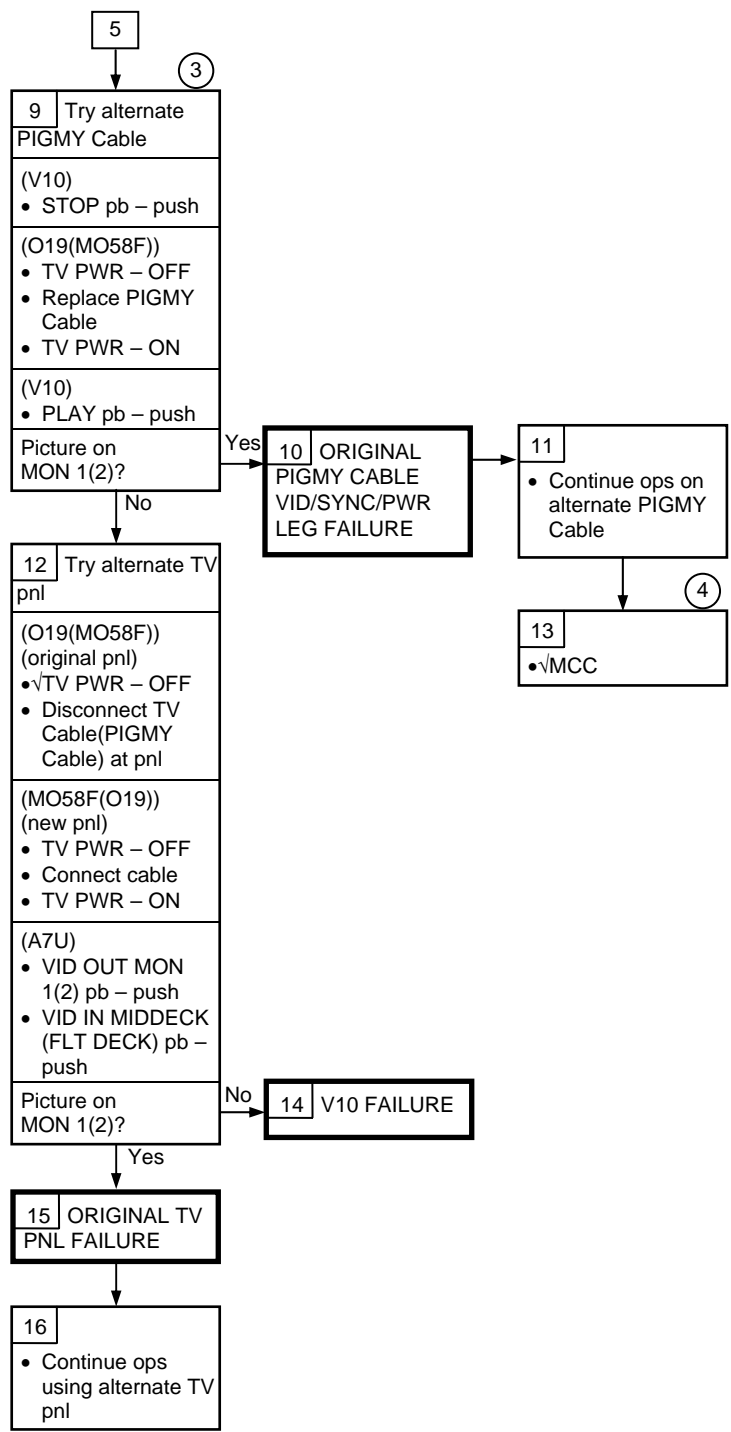

③  
√MCC if alternate equip avail

④  
IFM for AVIU(cables) may be possible

**CCTV**

**10.4 NO CAMCORDER VIDEO ON COLOR TV MONITOR**

10.1 17  
 10.1 44  
 10.2 2

No Camcorder Video

**Nominal Config:**

(R14:D)  
 cb MNA TV CONTR UNIT - cl  
 cb MNA TV MON 1 - cl  
 cb MNB TV CONTR UNIT - cl  
 cb MNB TV MON 2 - cl  
 cb MNC TV CAB - cl

(A7U)  
 TV PWR CNTL - CMD  
 TV PWR CONTR UNIT - MNA(MNB)  
 TV SYNC - NORM  
 TV DNK - ENA

(A3)  
 MON 1(2)  
 SOURCE - as reqd  
 SYNC - INT  
 PWR - ON  
 MODE - AUTO  
 GUNS - R,G,B - ON

(PD100)  
 MODE - CAMERA

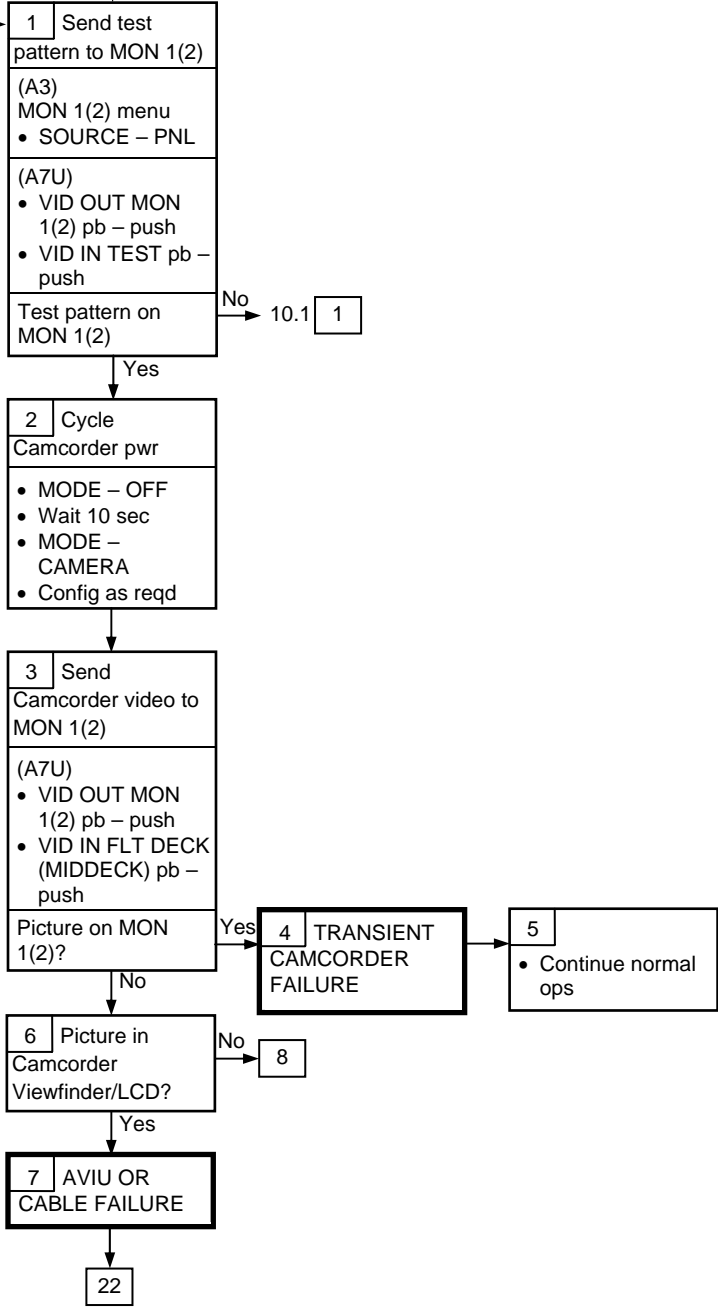

**CCTV 10.4 (Cont)**

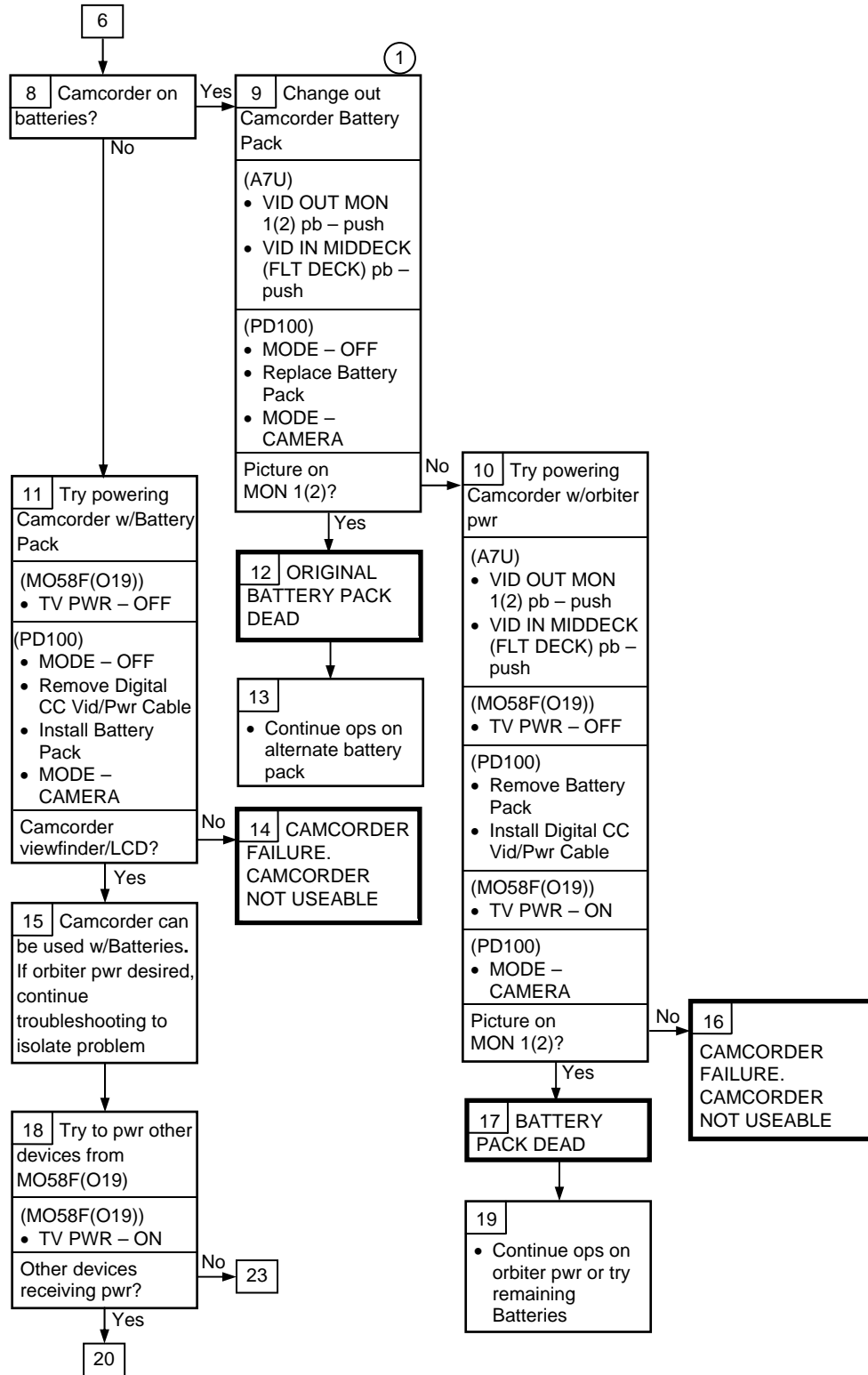

①  
Video link from Camcorder to orbiter TV pnl should already be connected via Digital CC Vid/Pwr cable, AVIU, and TV Pwr cable when viewing Camcorder video on orbiter color TV monitor

**CCTV 10.4 (Cont)**

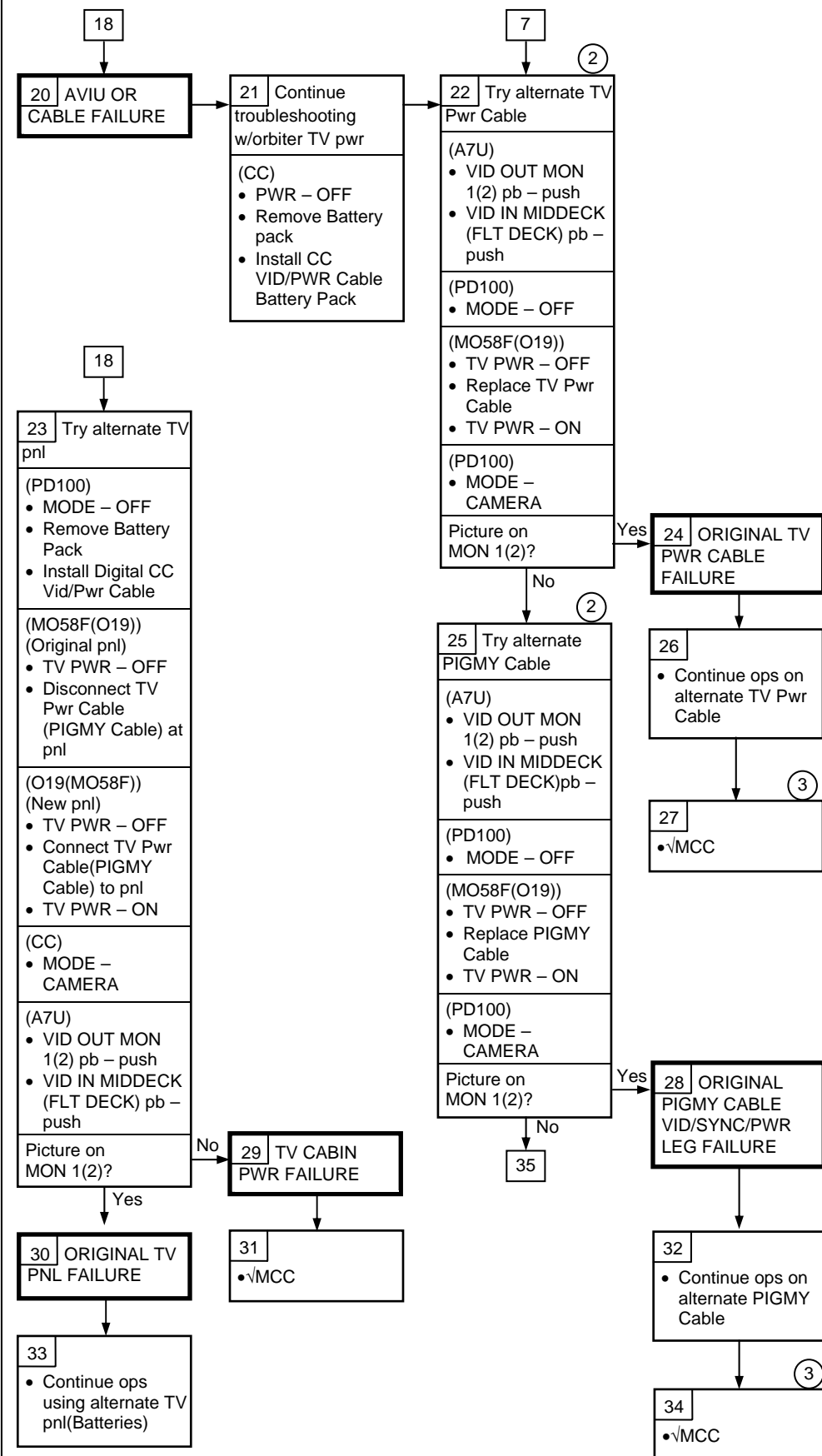

②  
√MCC if alternate equip not avail

③  
IFM for AVIU or cables may be possible

# CCTV 10.4 (Cont)

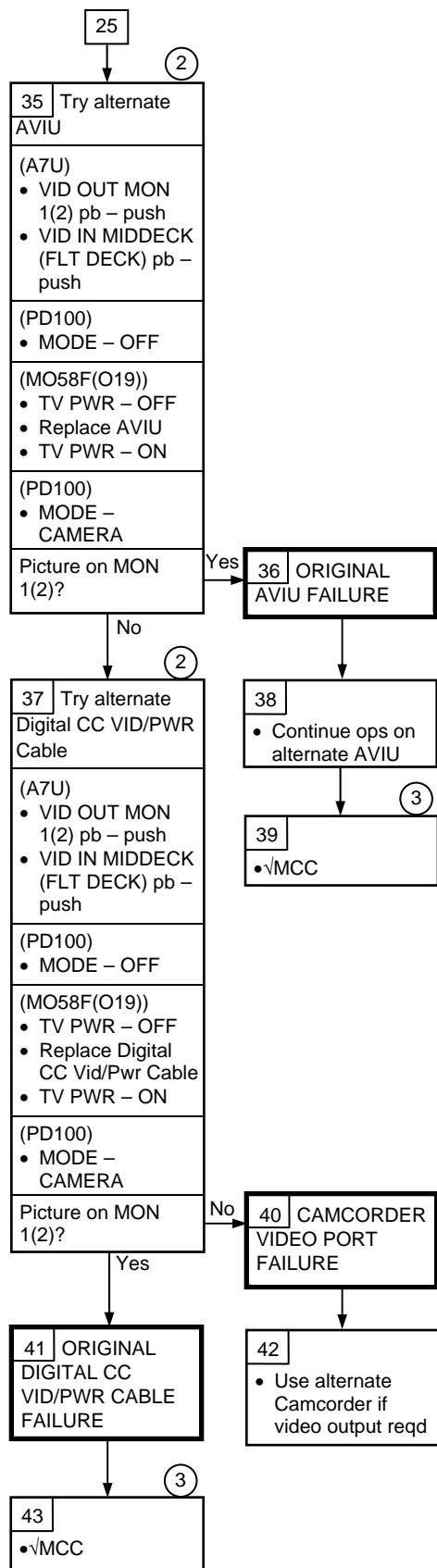

②  
√MCC if alternate  
equip not avail

③  
IFM for AVIU or  
cables may be  
possible

# CCTV

## 10.5 RMS TV cb OPENS

Port RMS TV Camr/Pan-Tilt cb Opens

**Nominal Config:**

(R14:D)  
 cb MNA TV CONTR UNIT – cl  
 cb MNA TV MON 1 – cl  
 cb MNB TV CONTR UNIT – cl  
 cb MNB TV MON 2 – cl  
 cb MNC TV CAB – cl

(R14:E)  
 cb MNB RMS PORT RMS TV CAMR/PAN-TILT – cl  
 CAMR HTR – cl  
 PAN-TILT HTR – cl

(A7U)  
 TV PWR CNTL – CMD  
 TV PWR CONTR UNIT – MNA(MNB)  
 TV SYNC – NORM  
 TV DNLK – ENA

(A3)  
 MON 1(2) SOURCE – as reqd  
 SYNC – INT  
 PWR – ON

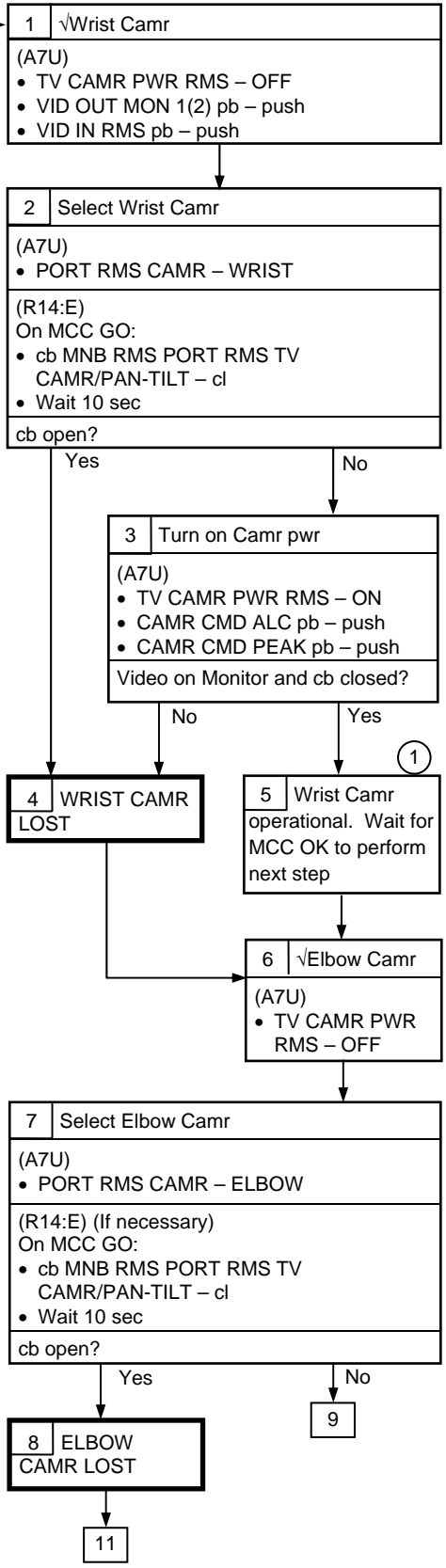

① Pwr routed to both Camrs at all times and switched inside Camrs. Short occurring in one Camr may cause loss of pwr to both Camrs on RMS. Decision to proceed based on current spikes, if any, and importance of RMS Camrs to remainder of mission



# CCTV 10.5 (Cont)

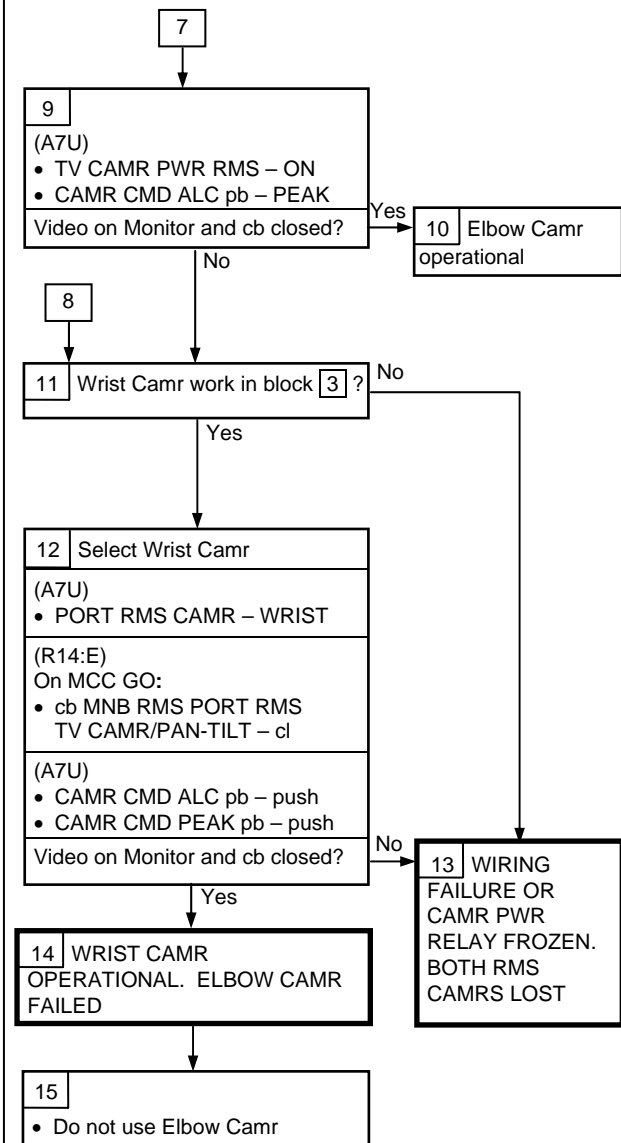

This Page Intentionally Blank

CENTERLINE (C/L) CAMR

	<u>PAGE</u>
C/L CAMR INSTALL.....	11-2
C/L CAMR VIDEO TROUBLESHOOT.....	11-5
C/L CAMR MISALIGNMENT .....	11-8
C/L CAMR OPS FOR VSU FAIL .....	11-10

# C/L CAMR

## CENTERLINE (C/L) CAMR

### C/L CAMR INSTALL

L12 (SSP 2) 1. ODS C/L Camr Config  
 ✓C/L CAM PWR – OFF

R12 (VPU) ✓SEC C/L Cap installed  
 ✓Green Jumper – SEC C/L  
 ✓VPU PWR – ON (LED on)

Unstow PRI C/L Camr, PRI C/L TV Camr Harness Assy per stowage plan

#### NOTE

When connecting ODS C/L TV Camr Harness Assy, ✓pins to socket connection

ODS ✓ODS C/L Camr Brkt mounted securely  
 Mount PRI C/L Camr to ODS C/L Camr Brkt  
 ✓Flex Duct attached to Camr brkt  
 Config cable per dwg at right

C/L Camr ✓SSF/STS sw – STS

L12 (SSP 1) ✓cb SW PWR 1 (CB2) – cl  
 (SSP 2) C/L CAM PWR – SEC ON

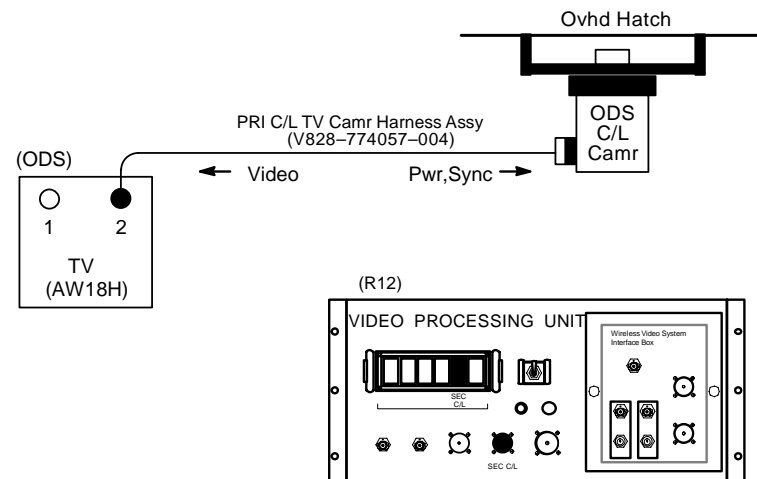

jsc48037\_048r2.cvx

# CENTERLINE (C/L) CAMR (Continued)

## C/L CAMR INSTALL (Continued)

### 2. Camr Position Verification

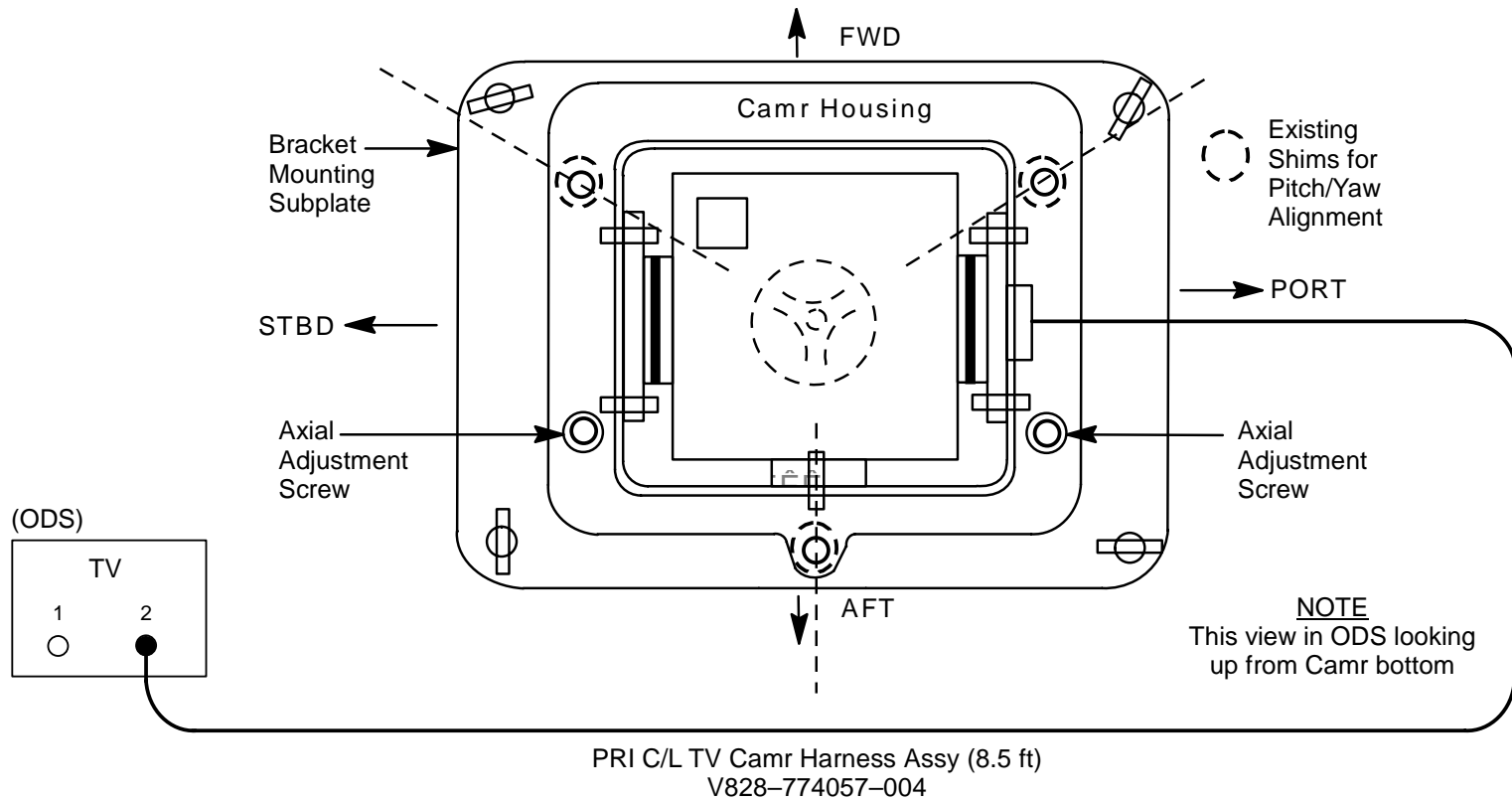

jsc48037\_049r2.cvx

## CENTERLINE (C/L) CAMR (Continued)

I

### C/L CAMR INSTALL (Concluded)

3. ODS C/L Camr Alignment Check  
Perform ACTIVATION (Cue Card, TV) as reqd

A7 VID OUT MON 1(2) pb – push  
IN PL2(VPU) pb – push  
ALC pb – push  
AVG pb – push

MON 1(2) LDATA – ON  
CDATA – GRN  
XHAIR – GRN

A7 Zoom to  $10^\circ \pm 0.5^\circ$   
Focus to see Xhair target

#### NOTE

Green xhairs on monitor may move off center in calibration target when zooming in,out. Xhair will be closest to center at full zoom in position

MON 1(2) ✓ Vertical xhairs coincide w/vertical alignment wire and are parallel. If xhair marks overlay each other, no yaw(axial) alignment needed (see dwg above)

✓ Intersection of monitor vertical, horizontal xhair falls within target circular opening from ~10-40° zoom range of Camr

Report results of both alignment verifications (at 10° and 40°) to MCC

4. Deactivation  
A7 CAMR CMD IRIS – CL  
L12 (SSP 2) C/L CAM PWR – OFF  
Go to DEACTIVATION (Cue Card, TV) as reqd

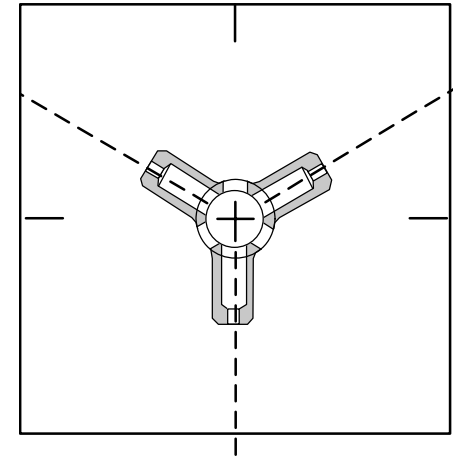

jsc48037\_050.cnv

## CENTERLINE (C/L) CAMR (Continued)

### C/L CAMR VIDEO TROUBLESHOOT

1. ✓C/L Camr nominal config:
- ODS Camr SSF/STS sw – STS
  - PRI C/L Camr connected via PRI C/L TV Camr Harness Assy to TV2 port
  - R12 (VPU) ✓VPU SEC C/L Cap installed on SEC C/L
  - ✓Green Jumper – SEC C/L
  - ✓VPU PWR – ON (lt ON)
  - L12 (SSP 1) ✓cb SW PWR 1 (CB2) – cl
  - (SSP 2) C/L CAM PWR – SEC ON
  - A7 VID OUT MON 1(2) pb – push
  - IN PL2(VPU) pb – push
  - A3 (MON) ✓C/L Camr Video

If no C/L Camr video on monitor:

2. Pwr-Cycle C/L Camr:
- A7 CAMR CMD IRIS – CL (hold 8 sec)
  - L12 (SSP 2) C/L CAM PWR – OFF, wait 10 sec, SEC ON
  - A7 ALC pb – push
  - AVG pb – push
  - A3 (MON) ✓C/L Camr Video

## CENTERLINE (C/L) CAMR (Continued)

### C/L CAMR VIDEO TROUBLESHOOT (Continued)

If still no C/L Camr video on monitor:

3. Change ODS TV port:
  - A7 CAMR CMD IRIS – CL (hold 8 sec)
  - L12 (SSP 2) C/L CAM PWR – OFF
  
  - ODS Disconnect PRI C/L TV Camr Harness Assy from TV2 port  
Connect PRI C/L TV Camr Harness Assy to TV1 port
  - R12 (VPU) √VPU PRI C/L Cap installed on PRI C/L  
Green Jumper – PRI C/L
  - L12 (SSP 2) C/L CAM PWR – PRI ON
  
  - A7 ALC pb – push  
AVG pb – push
  - A3 (MON) √C/L Camr Video

If still no C/L Camr video on monitor:

4. Change C/L TV Camr Harness Assy:
  - A7 CAMR CMD IRIS – CL (hold 8 sec)
  - L12 (SSP 2) C/L CAM PWR – OFF
  
  - L12 (SSP 2) Unstow SEC C/L TV Camr Harness Assy per stowage plan  
Disconnect PRI C/L TV Camr Harness Assy from ODS TV1 port and PRI C/L Camr  
Connect SEC C/L TV Camr Harness Assy to ODS TV1 and PRI C/L Camr  
C/L CAM PWR – PRI ON
  
  - A7 ALC pb – push  
AVG pb – push
  - A3 (MON) √C/L Camr Video



## CENTERLINE (C/L) CAMR (Continued)

### C/L CAMR VIDEO TROUBLESHOOT (Concluded)

If still no C/L Camr video on monitor:

5. Install SEC C/L Camr:
- |             |   |
|-------------|---|
| A7          | CAMR CMD IRIS – CL (hold 8 sec)                           |
| L12 (SSP 2) | C/L CAM PWR – OFF   |
|             | Unstow SEC C/L TV Camr per stowage plan                   |
|             | Disconnect SEC C/L TV Camr Harness Assy from PRI C/L Camr |
|             | Remove PRI C/L Camr from ODS C/L Camr Brkt                |
|             | Mount SEC C/L Camr to ODS C/L Camr Brkt                   |
| L12 (SSP 2) | Connect SEC C/L TV Camr Harness Assy to SEC C/L Camr      |
|             | C/L CAM PWR – PRI ON                                      |
| A7          | ALC pb – push   |
|             | AVG pb – push   |
| A3 (MON)    | √C/L Camr Video   |

If video, perform C/L CAMR INSTALL, step 3

If still no C/L Camr video on monitor:

6. √MCC

## CENTERLINE (C/L) CAMR (Continued)

### C/L CAMR MISALIGNMENT

If green xhair outside inner diameter of circular portion of calibration target during PRI C/L Camr alignment, perform following:

1. Describe to MCC location of xhair in relation to target circle. Reference dwgs, 11-9
2. Remove, re-install Camr to bridge. Recheck alignment per C/L CAMR INSTALL, step 3

Perform each of the remaining steps if misalignment persists:

3. Remove, re-install mounting bridge to ODS. Recheck alignment per C/L CAMR INSTALL, step 3
4. Shim Camr/bridge interface:
  - a. Obtain feeler gauges from ML60B Primary C/L Foam
  - b. Loosen fasteners on Camr/bridge interface
  - c. Insert feeler gauge between Camr brkt and bridge as appropriate to center xhair and tighten fasteners
  - d. Recheck alignment per C/L CAMR INSTALL, step 3
  - e. Repeat as reqd w/different sized feeler gauges or shim locations until xhair within target circle
5. Install SEC C/L Camr using PRI C/L Camr Harness Assy and ODS TV Port 2 (no change to VPU selections) per stowage plan:

A7	CAMR CMD IRIS – CL (hold 8 sec)
L12 (SSP 2)	C/L CAM PWR – OFF
ODS	Disconnect Camr Harness Assy from PRI C/L Camr
	Replace PRI C/L Camr w/SEC C/L Camr
	Connect Camr Harness Assy to SEC C/L Camr
L12 (SSP 2)	C/L CAMR PWR – SEC ON
A7	ALC pb – push
	AVG pb – push

Check alignment per C/L CAMR INSTALL, step 3. Describe misalignment to MCC per step 1

6. Repeat step 4 for SEC C/L Camr
7. If shimming both PRI and SEC C/L Camrs fails to bring xhair within target circle, re-install Camr w/best alignment. Report which Camr installed
8. √MCC to determine if ODS CENTERLINE CAMR ANGULAR ALIGNMENT (IFM, PROCEDURES M THRU R) reqd

**CENTERLINE (C/L) CAMR (Continued)**

**C/L CAMR MISALIGNMENT (Concluded)**

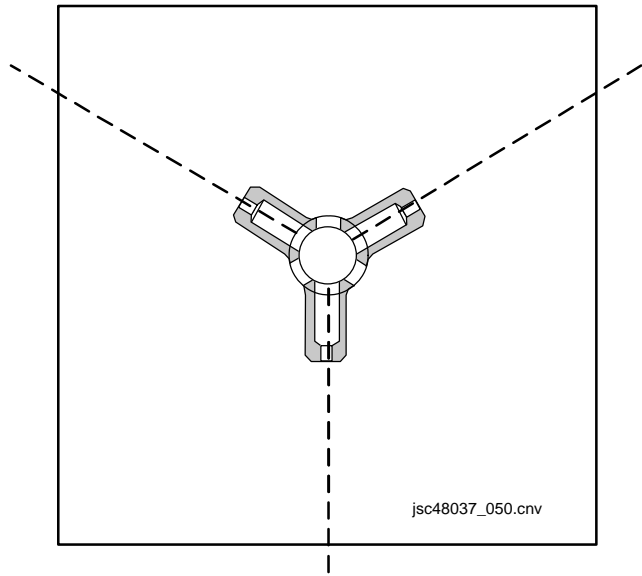

PRI C/L CAMR

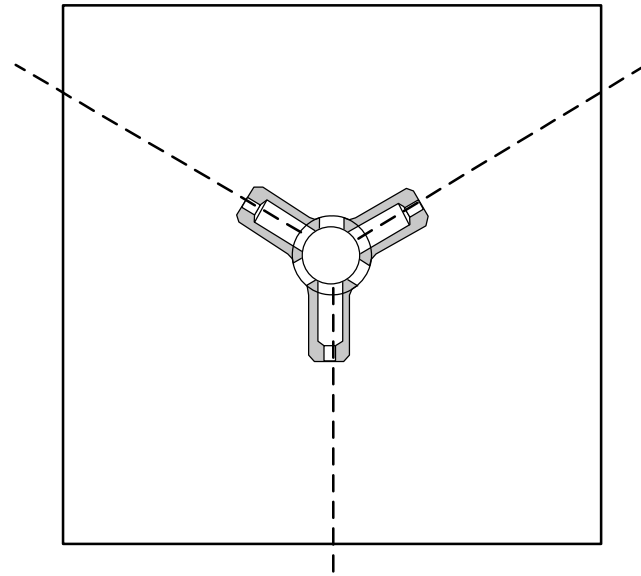

SEC C/L CAMR

jsc48037\_051.cnv

## CENTERLINE (C/L) CAMR (Continued)

### C/L CAMR OPS FOR VSU FAIL

	1. <u>Setup</u>				2. <u>Activation</u>
	Obtain:		TVCU		CENTERLINE/CAMCORDER sw – CENTERLINE
	TVCU/CIP I/F Cable		O19		TV Pwr – ON
	TVCU		L12		C/L CAM PWR – SEC ON
	Camr Cont/CTVM Cable		(SSP 2)		
	TV Pwr Cable (20 ft) (2)				PGSC PWR SOURCE – ON
	AVIU LCD Cable				PGSC – ON
	LCD		A31p		
	RS-232 Cable				cb MNB TV MON 2 – cl
	PGSC		R14:D		MON 2 PWR – ON
	PGSC Pwr Cable(s)		A3		
	PIGMY				PWR – ON (LED on)
	AVIU		V10		√Tape – Installed
	V10				
	MON to VIU/CM Cable				PWR – ON
	Digital CC VID/PWR Cable		LCD		
	AVIU-CC VID Cable				
			A31p		Insert TVCU Boot CD
A3	√MON 2 PWR – OFF				Shutdown Windows
R14:D	cb MNB TV MON 2 – op				Pwr on A31p while holding down F12 key until
A3	Disconnect Pwr MNB from MON 2 J1				'Boot Menu' appears
					Sel '3. CD-ROM Drive' using down arrow
	Config per dwg, 11-11				(selected when text white)
					<Enter>
					CTVC CONTROLLER menu
					CAMERA (click)
					P2 (click)
					ALC – AVG (click)
					Return to P/TV scene as reqd
					CTVC CONTROLLER menu
					√Zoom,Iris,Focus as reqd



## CENTERLINE (C/L) CAMR (Concluded)

### C/L CAMR OPS FOR VSU FAIL (Concluded)

A31p      3. Deactivation  
CTVC CONTROLLER menu  
    IRIS – CLOSE  
    QUIT

            PGSC – OFF  
            PGSC Pwr Source – OFF

L12 (SSP 2)    C/L CAM PWR – OFF

O19            TV PWR – OFF

LCD            PWR – OFF

MON 2         Pwr – OFF  
                Stow hardware as reqd

I

DTV

	<u>PAGE</u>
SPECIFICATIONS.....	12-2
NOMENCLATURE.....	12-3
VTR (SONY DSR-25) NOMINAL MENU SETTINGS .....	12-13
DTV FUNCTIONAL SCHEMATIC .....	12-14
VTR CLOCK SET .....	12-15
MALS .....	12-16
12.1 NO VIDEO AT VTR OUT .....	12-16
12.2 NO DIGITAL DNLK VIDEO AT MCC .....	12-16
12.3 MUX PWR LED(s) OFF .....	12-17
12.4 MUX CHANNEL 3 DATA LED OFF .....	12-17
12.5 VIP PWR LED OFF .....	12-18
12.6 VIP DATA FLOW LED OFF .....	12-18
12.7 VTR ON/STANDBY RED LED OFF .....	12-19
12.8 VTR STARTS RECORDING OR REWINDS AND STARTS PLAYING AFTER MUX PWR APPLIED .....	12-19
12.9 VTR TAPE CONTROLS NOT FUNCTIONING (VTR DISPLAY INDICATES "ERR") .....	12-19
12.10 VTR DISPLAYS ERROR MSG 32 .....	12-19
12.11 VTR DISPLAYS ERROR MSG 21 .....	12-20
12.12 VTR AUTOMATICALLY PWRS OFF .....	12-20

## DTV

### DTV

#### SPECIFICATIONS

##### VIP

PWR SOURCE: 400 Hz A/C via AC2 PAYLOAD 3 $\Phi$  (MA73C:E)  
PWR DRAW: 6.84 Watts  
FUSES: F1 = 5 amp  
          F2 = 2 amp  
WEIGHT: 4.19 lb  
DIMENSION: 10.5" (L) X 5.25" (W) X 2.69" (H)

##### VTR (SONY DSR-25)

PWR SOURCE: 13.2 VDC via MUX  
PWR DRAW: 12.88 to 33.6 Watts (depending on mode)  
TAPE: Standard DVCAM or Mini DVCAM  
TAPE LENGTH: 3 hr or 40 min  
AUDIO: 2 Channel, 16 bit at 48 KHz  
CLOCK PWR: 300 hr internal rechargeable capacitor (after 8 hr charge)  
OPERATING TEMP: 41 degF to 104 degF  
WEIGHT: 9 lb  
DIMENSION: 15.5" (L) X 8.37" (W) X 3.87" (H)

##### MUX

PWR: 28 VDC via PAYLOAD AUX bus (R1)  
PWR DRAW: 39.76 to 72.8 Watts (depending on VTR,CC config)  
FUSE: 5 amp  
WEIGHT: 15.2 lb  
DIMENSION: 19" (L) X 17.88" (W) X 3.45" (H)



# DTV (Continued)

## NOMENCLATURE

### VIP

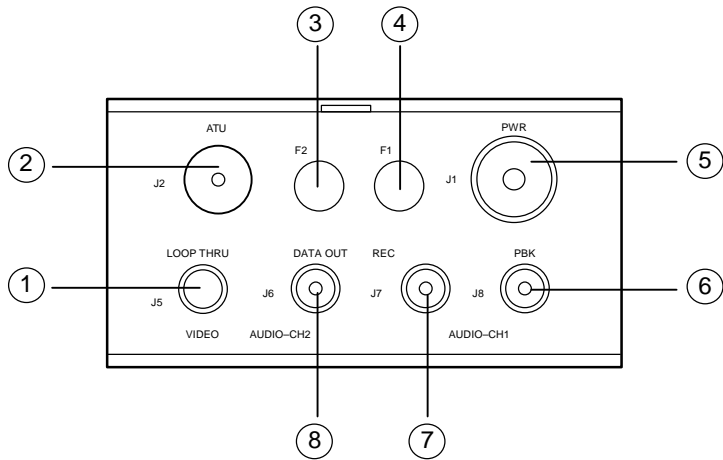

**BACK**

- ① Video Loop Thru Connector (J5)
- ② ATU Audio Connector (J2)
- ③ F2: 2–Amp Fuse
- ④ F1: 5–Amp Fuse
- ⑤ AC Pwr Connector (J1)
- ⑥ Playback Audio Connector (J8)
- ⑦ Record Audio Connector (J7)
- ⑧ Interval DATA OUT Connector (J6)

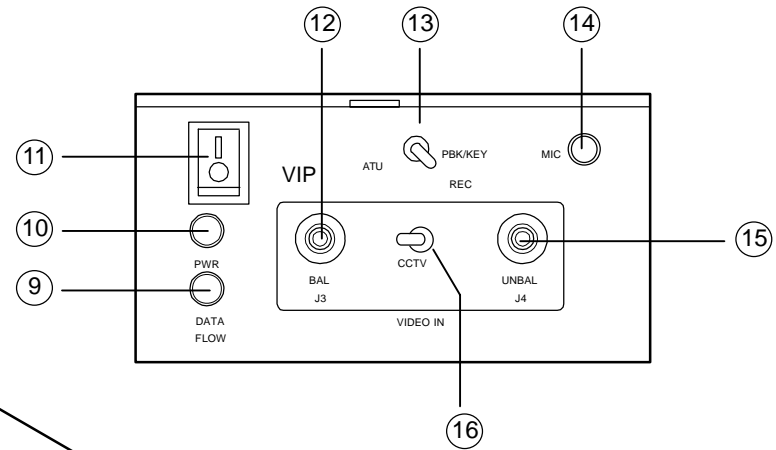
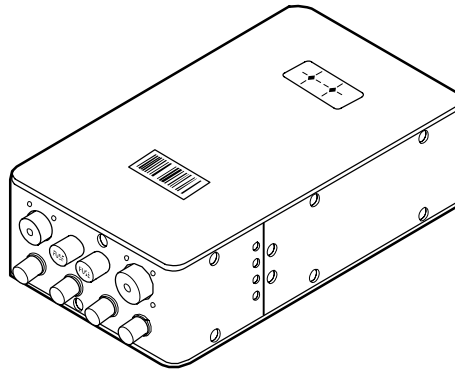

**FRONT**

- ⑨ Data Flow LED (green)
- ⑩ PWR LED (green)
- ⑪ PWR sw
- ⑫ Balanced Video Connector (J3)
- ⑬ ATU sw
- ⑭ PLAYBACK/KEY MIC LED
- ⑮ Unbalanced Video Connector (J4)
- ⑯ CCTV VIDEO IN sw

jsc48037\_054\_r1.cvx

## DTV (Continued)

### NOMENCLATURE (Continued)

#### VTR (SONY DSR-25) – FRONT PANEL

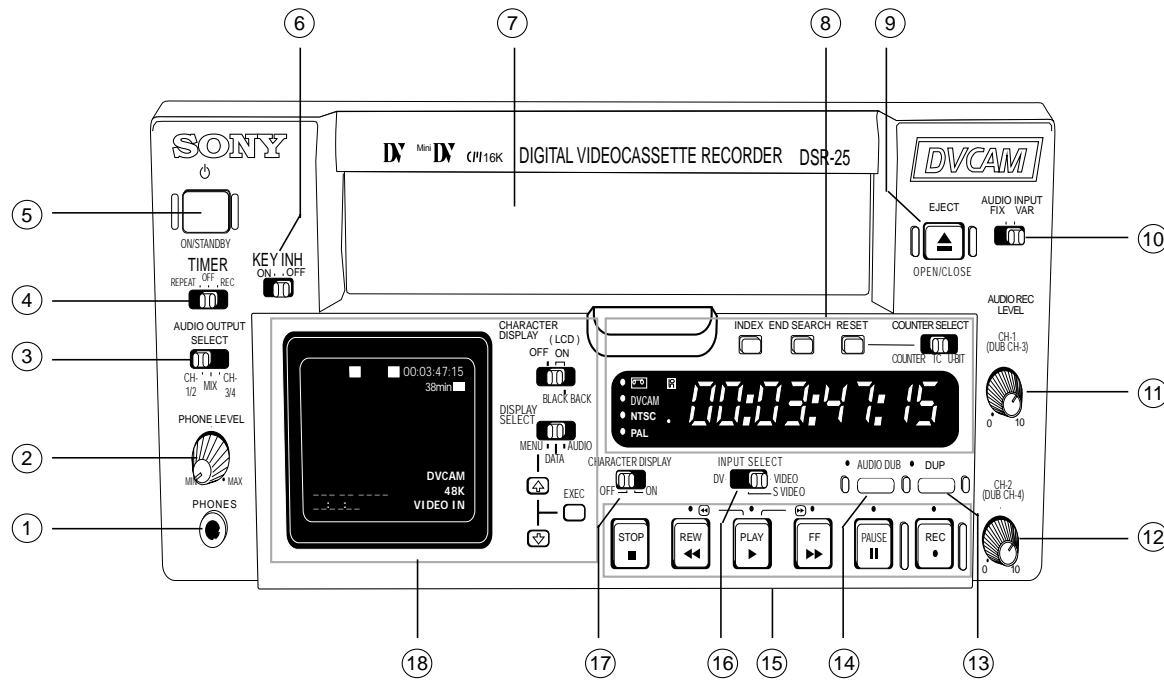

- ① Phone Jacks
- ② PHONE LEVEL Control kb
- ③ AUDIO OUTPUT SELECT sw (CH 1/2)
- ④ TIMER sw (OFF)
- ⑤ ON/STANDBY pb, LED (red/green)
- ⑥ KEY INH sw (OFF)
- ⑦ Cassette Compartment
- ⑧ Display Window and Controls
- ⑨ EJECT pb
- ⑩ AUDIO INPUT sw (FIX)
- ⑪ CH-1 AUDIO REC LEVEL Control kb (N/A)
- ⑫ CH-2 AUDIO REC LEVEL Control kb (N/A)
- ⑬ DUP pb (not used)
- ⑭ AUDIO DUB pb (N/A)
- ⑮ Tape Transport Controls
- ⑯ INPUT SELECT sw (VIDEO)
- ⑰ CHARACTER DISPLAY sw (OFF)
- ⑱ Monitor Display and Controls

jsc48037\_139r4.cvx

## DTV (Continued)

### NOMENCLATURE (Continued)

#### VTR (SONY DSR-25) – FRONT PANEL (Concluded)

①	PHONES jack	Stereo headphone connection point to monitor live(playback) audio
②	PHONE LEVEL kb	Controls headphone jack volume level
③	AUDIO OUTPUT SELECT sw (Default = CH 1/2)	Determines which audio channels are output in 32 kHz mode only
④	TIMER sw (Default = OFF)	Used to auto repeat a tape or automatically start recording once pwr is applied to VTR
⑤	ON/STANDBY pb, LED (red/green)	Changes pwr mode of VTR between STANDBY (red LED) and ON (green LED). Will automatically go to ON when MUX pwr applied
⑥	KEY INH sw (Default = OFF)	Disables all pbs when ON
⑦	Cassette Compartment	Tape insertion location, door opened/closed via EJECT pb
⑧	Display windows and controls	See 12-6 for details
⑨	EJECT pb	Opens/closes cassette compartment door and ejects tape, if installed
⑩	AUDIO INPUT sw (Default = FIX)	Enables/disables AUDIO REC LEVEL control knobs. FIX sets fixed gain based on AUDIO INPUT LEVEL sw on rear of VTR
⑪	CH-1 AUDIO REC LEVEL kb (N/A)	Controls audio level of orbiter audio
⑫	CH-2 AUDIO REC LEVEL kb (N/A)	Controls audio level for VI data
⑬	DUP pb (not used)	Used for tape-to-tape recording to duplicate the time code
⑭	AUDIO DUB pb (N/A)	Used for tape-to-tape recording to duplicate the 32 kHz mode audio channels
⑮	Tape Transport Controls	See 12-7 for details
⑯	INPUT SELECT sw (Default = VIDEO)	Determines which video input jack the VTR will process
⑰	CHARACTER DISPLAY sw (Default = OFF)	Determines if VTR monitor text is displayed in VTR OUT video
⑱	Monitor Display and Controls	See 12-8 for details

## DTV (Continued)

### NOMENCLATURE (Continued)

#### VTR (SONY DSR-25) – DISPLAY WINDOW AND CONTROLS

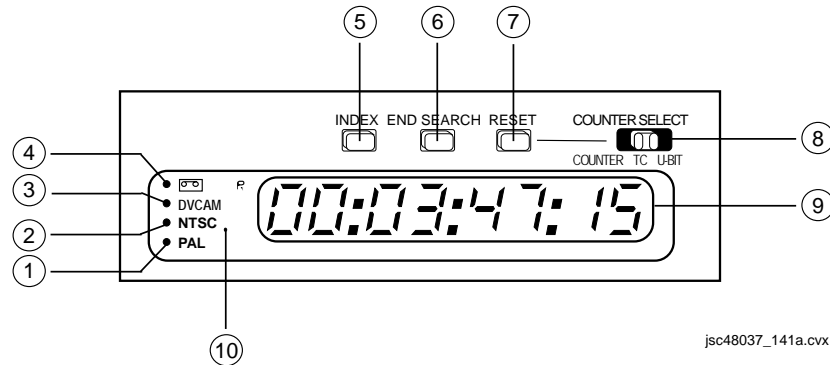

jsc48037\_141a.cvx

①	PAL Indicator/Amber (not used)	Lit when NTSC/PAL sw is in PAL posn or PAL formatted video being processed by the VTR
②	NTSC Indicator/Amber (on)	Lit when NTSC/PAL sw is in NTSC posn or NTSC formatted video being processed by the VTR
③	DVCAM Indicator/Amber (on)	Lit when the VTR is playing a DVCAM-formatted tape or when the VTR is set to DVCAM
④	Cassette Indicator/Amber	Lit solid when a tape is loaded into the VTR. Flashes during tape ejection
⑤	INDEX pb	Initiates index mark on the tape that can be used to cue the tape to that posn on the tape via INDEX SEARCH
⑥	END SEARCH pb	VTR will search for the last 5 sec of recorded video, play it, and return to stop mode
⑦	RESET pb	Resets COUNTER displayed numbers to all zeroes
⑧	COUNTER SELECT sw	Determines which time data will be displayed in the counter display
	COUNTER	Count value of the counter (DD:HH:MM:SS)
	TC	Time code
	U-BIT	User bits (not used)
⑨	Time Counter Display	Displays time data (counter/time code/user bits). Self-diagnosis code numbers or error msgs
⑩	Remote Control Detector	Self explanatory

## DTV (Continued)

### NOMENCLATURE (Continued)

#### VTR (SONY DSR-25) – TAPE TRANSPORT CONTROLS

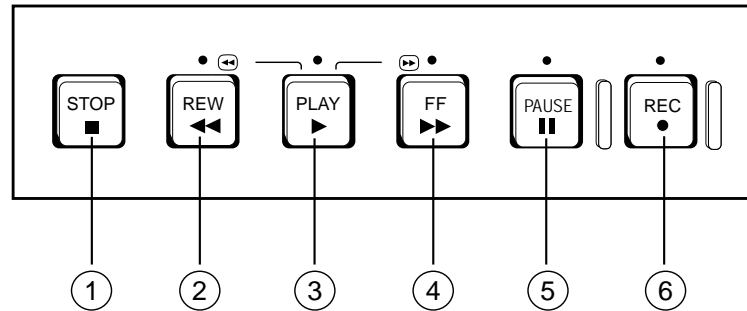

jsc48037\_141b.cvx

①	STOP pb	Stops current tape transport operation
②	REW pb/Indicator/Amber	Rewinds tape and illuminates the REW indicator. Video not visible unless held during play or play/pause mode
③	PLAY pb/Indicator/Green	Starts playback ops and illuminates the PLAY indicator
④	FF pb/Indicator/Amber	Fast forwards tape and illuminates the FF indicator. Video not visible unless held during play or play/pause mode
⑤	PAUSE pb/Indicator/Amber	Pauses playback or recording ops
⑥	REC pb/Indicator/Red	Pressing PLAY pb while holding in REC pb will start recording and both PLAY and REC indicators will illuminate. Just pressing REC pb will illuminate the REC indicator and allow for audio,video monitoring

## DTV (Continued)

### NOMENCLATURE (Continued)

#### VTR (SONY DSR-25) – MONITOR DISPLAY AND CONTROLS

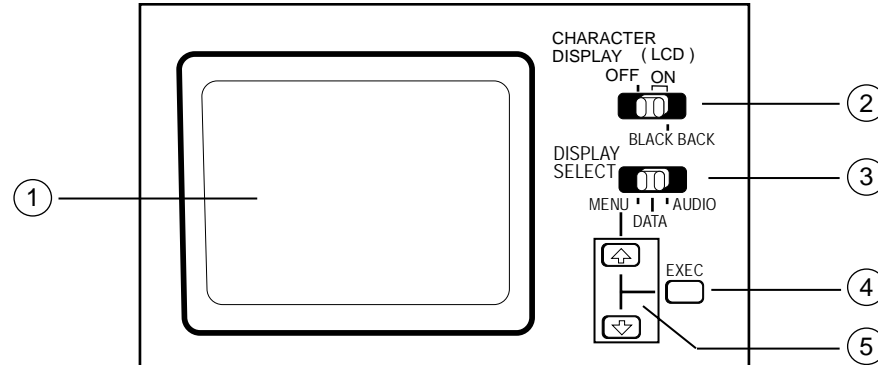

jsc48037\_141c.cvx

①	LCD Monitor	Displays playback(live) video and superimposed text, audio levels, and menu data
②	CHARACTER DISPLAY (LCD) sw (Default = ON)	Controls the display of superimposed text on the monitor. BLACK BACK will block video flow to the monitor to provide a black background to improve superimposed data viewing
③	DISPLAY SELECT sw	Determine what superimposed data is displayed on the monitor
	MENU	Menu data
	DATA	VTR information
	AUDIO	Audio levels
④	EXEC pb	Executes and selects menu items
⑤	↑↓ pbs	Allows navigation through and setting of menu items when in MENU mode, and adjusts monitor brightness when in DATA mode

## DTV (Continued)

### NOMENCLATURE (Continued)

#### VTR (SONY DSR-25) – REAR PANEL

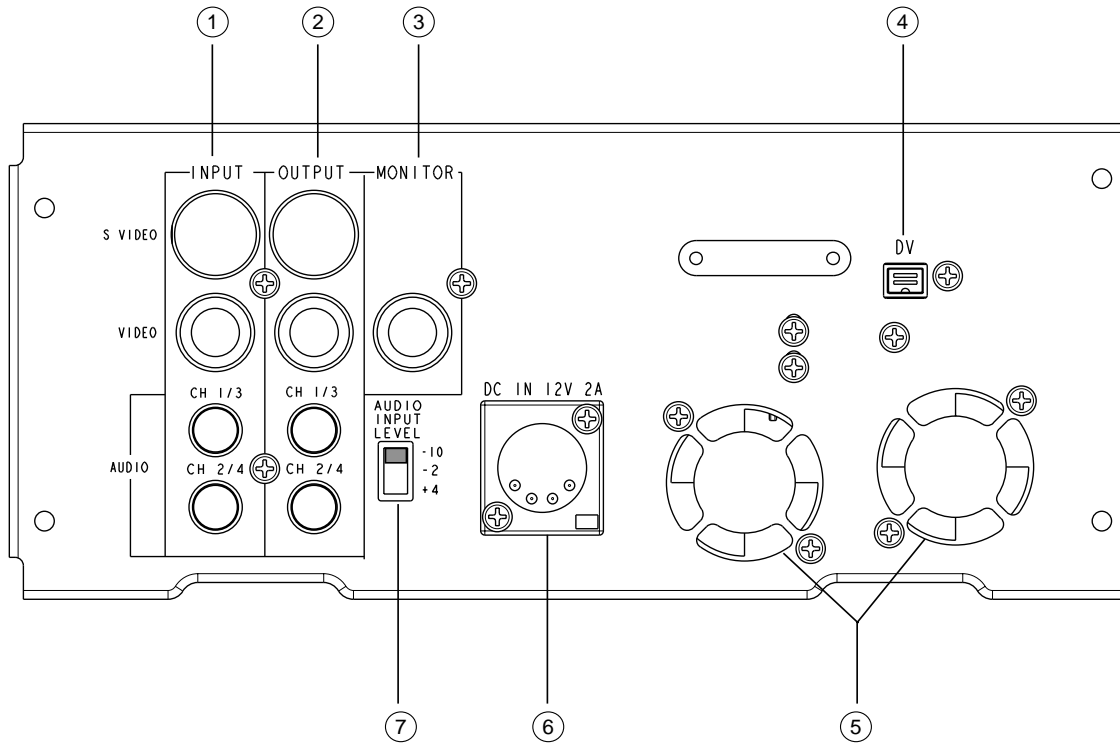

- ① INPUT Jacks
- ② OUTPUT Jacks
- ③ MONITOR Jack
- ④ DV Jack
- ⑤ Cooling Fan (two)
- ⑥ DC IN Connector
- ⑦ AUDIO INPUT LEVEL sw (-10)

jsc48037\_140r4.cvx

## DTV (Continued)

### NOMENCLATURE (Continued)

#### VTR (SONY DSR-25) – REAR PANEL (Concluded)

①	INPUT Jacks	Video and audio inputs
	S_VIDEO	Not used
	VIDEO	Video input of DTV signal from orbiter VSU
	AUDIO CH-1/3	Orbiter audio input
	AUDIO CH-2/4	Orbiter "VI" input
②	OUTPUT Jacks	Video and audio outputs
	S_VIDEO	Not used
	VIDEO	VTR OUT video (No VI data)
	AUDIO CH-1/3	Orbiter audio playback output
	AUDIO CH-2/4	Not used
③	MONITOR Jack	VTR MON Video (Note: Will not display VTR Playback Video)
④	DV Jack	IEEE 1394 4-pin video/audio connection
⑤	Cooling Fans	Reversed to bring air into unit
⑥	DC IN Connector	DC pwr source connection
⑦	AUDIO INPUT LEVEL sw	Sets the audio fixed gain level when the AUDIO INPUT is set to FIX. Default is -10. Is ignored in the VAR setting



# DTV (Continued)

## NOMENCLATURE (Continued)

### MUX – FRONT

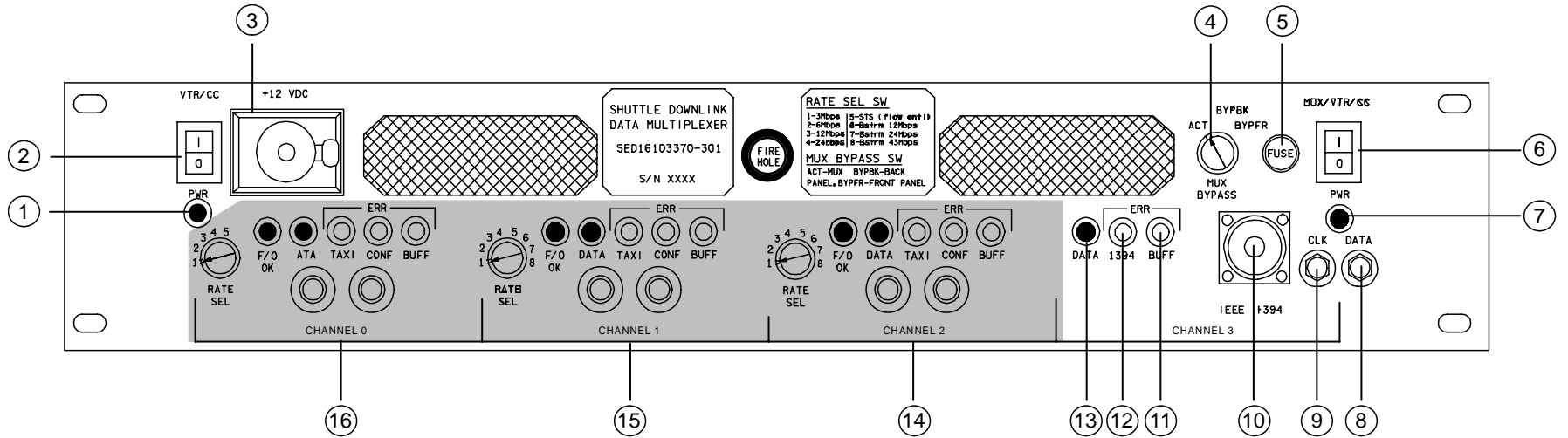

- |                           |                                       |
|---------------------------|---------------------------------------|
| ① VTR/CC PWR LED (green)  | ⑨ BYPFRR CLOCK Connector              |
| ② VTR/CC PWR sw           | ⑩ IEEE 1394 Connector                 |
| ③ +12 VDC Connector (N/A) | ⑪ CHANNEL 3 BUFFER ERROR LED (yellow) |
| ④ MUX BYPASS sw           | ⑫ CHANNEL 3 1394 ERROR LED (yellow)   |
| ⑤ MUX 5-Amp Fuse          | ⑬ CHANNEL 3 DATA LED (green)          |
| ⑥ MUX/VTR/CC sw           | ⑭ CHANNEL 2 DATA Ports,LEDs (N/A)     |
| ⑦ MUX PWR LED (green)     | ⑮ CHANNEL 1 DATA Ports,LEDs (N/A)     |
| ⑧ BYPFRR DATA Connector   | ⑯ CHANNEL 0 DATA Ports,LEDs (N/A)     |

jsc48037\_058.cnv

## DTV (Continued)

### NOMENCLATURE (Concluded)

#### MUX – BACK

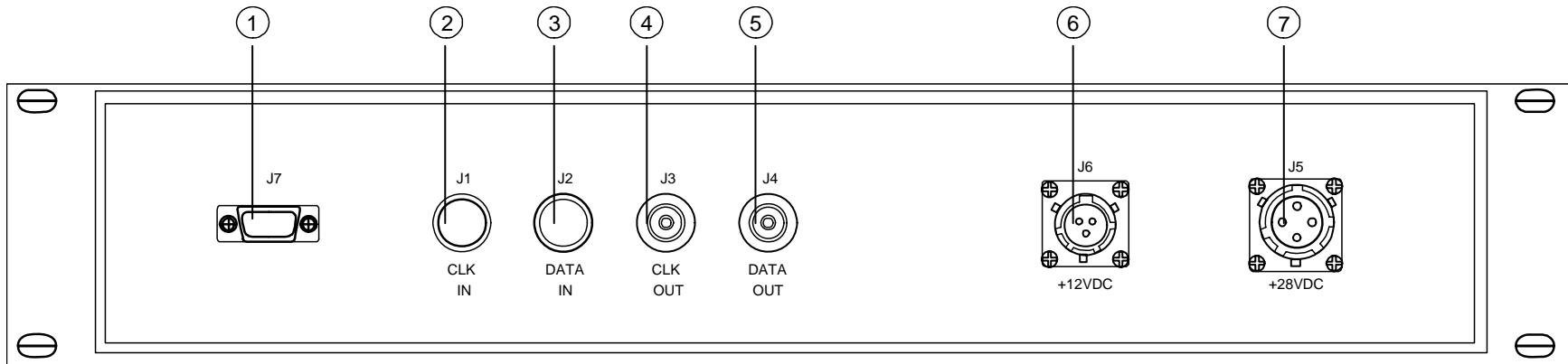

- ① DATA Port (N/A)
- ② CLOCK IN Connector (J1)
- ③ DATA IN Connector (J2)
- ④ CLOCK OUT Connector (J3)
- ⑤ DATA OUT Connector (J4)
- ⑥ +12 VDC OUTPUT Connector (J6)
- ⑦ +28 VDC INPUT Connector (J5)

jsc48037\_059.cnv

## **MULTI-PROTOCOL CONVERTER (MPC)**

### **SPECIFICATIONS**

DOWNLINK: HDV signal via ISS High Rate Data Link (HRDL)

INTERFACES: IEEE1394 (Firewire) for HDV  
RJ-45 for Ethernet to an SSC (not used)  
ST for TAXI link to ISS via HRFM

POWER: 16VDC

TAXI OUTPUT: 68Mbps (maximum) bitstream only (HDV rate ~30Mbps)

HDV INPUT: 27Mbps (Average)

ETHERNET INPUT: 50Mbps maximum by UDP/IP (not used)

ETHERNET PROTOCOL: FTP, TFTP, UDP

DIMENSIONS: 203mm x 187mm x 41mm  
(8" x 7.4" x 1.6")

MASS: 1.0kg (2.2 lb)

## Multi-Protocol Converter

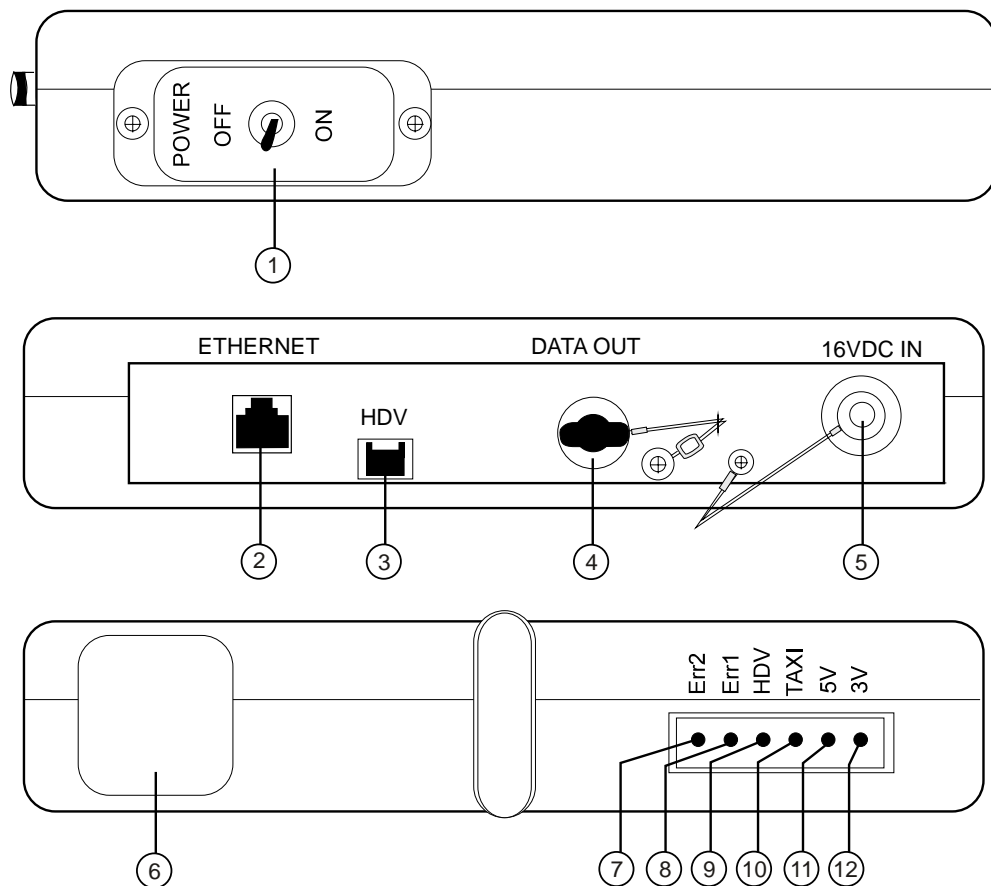

- ① sw POWER - ON/OFF
- ② ETHERNET - For file transfer
- ③ HDV - High definition video firewire input from Camcorder
- ④ DATA OUT - Processed HDV signal that goes to downlink
- ⑤ 16VDC IN - Power using a black brick.
- ⑥ Fan
- ⑦ Err2 - LED indicator for ETHERNET data dropped or lost sync
- ⑧ Err1 - LED indicator for HDV data dropped or lost sync
- ⑨ HDV - LED indicator fo HDV data received
- ⑩ TAXI - LED indicator for TAXI data forwarded
- ⑪ 5V - Power LED indicator for 5VDC/DC converter
- ⑫ 3V - Power LED indicator for 3.3VDC/DC converter

JSC48037\_MPC.CVX

**DTV (Continued)**

**VTR (SONY DSR-25) NOMINAL MENU SETTINGS**

MENU	SUB MENU
TC (TC/UB SET)	TC PRESET – N/A
	UB PRESET – N/A
	DV IN TC – INTERNAL
	TC MAKE – REGEN
	TC RUN – REC RUN
	TC FORMAT – AUTO

CM (CM SET)	CM SEARCH – ON
	TITLE DISP – ON
	LABEL DISP – ON
	TAPE LABEL – N/A
	ITEM ERASE – N/A
	ERASE ALL – N/A

DISP (DISPLAY SET)	DATA CODE – DATE (non-default)
	EE/PB SEL – EE
	LTR SIZE – NORMAL
	COLOR BAR – OFF
	DATE DISP – M/D/Y
	TIME DISP – 24H

V (VIDEO SET)	PB YNR – OFF
	PB CNR – OFF

MENU	SUB MENU
A (AUDIO SET)	AUDIO MODE – FS48k (non-default)
	JOG AUDIO – OFF

VTR (VTR SET)	REC MODE – DVCAM
	AUTO INDEX – ON
	STILL PICT – AUTO
	FF/REW SPD – FF/REW
	DUPLICATE – N/A
	DV EE OUT – ON (non-default)
STILL TIME – 1 MIN (non-default)	
	FROM STILL – STOP

ETC (OTHERS)	COMMANDER – WIRELESS
	AC ON MODE – POWER ON (non-default)
	AUTO STBY – DISABLE
	BEEP – ON
	LCD BRIGHT – mid
	LCD COLOR – mid
	CLOCK SET – GMT
HRS METER – N/A	

# DTV (Continued)

## DTV FUNCTIONAL SCHEMATIC

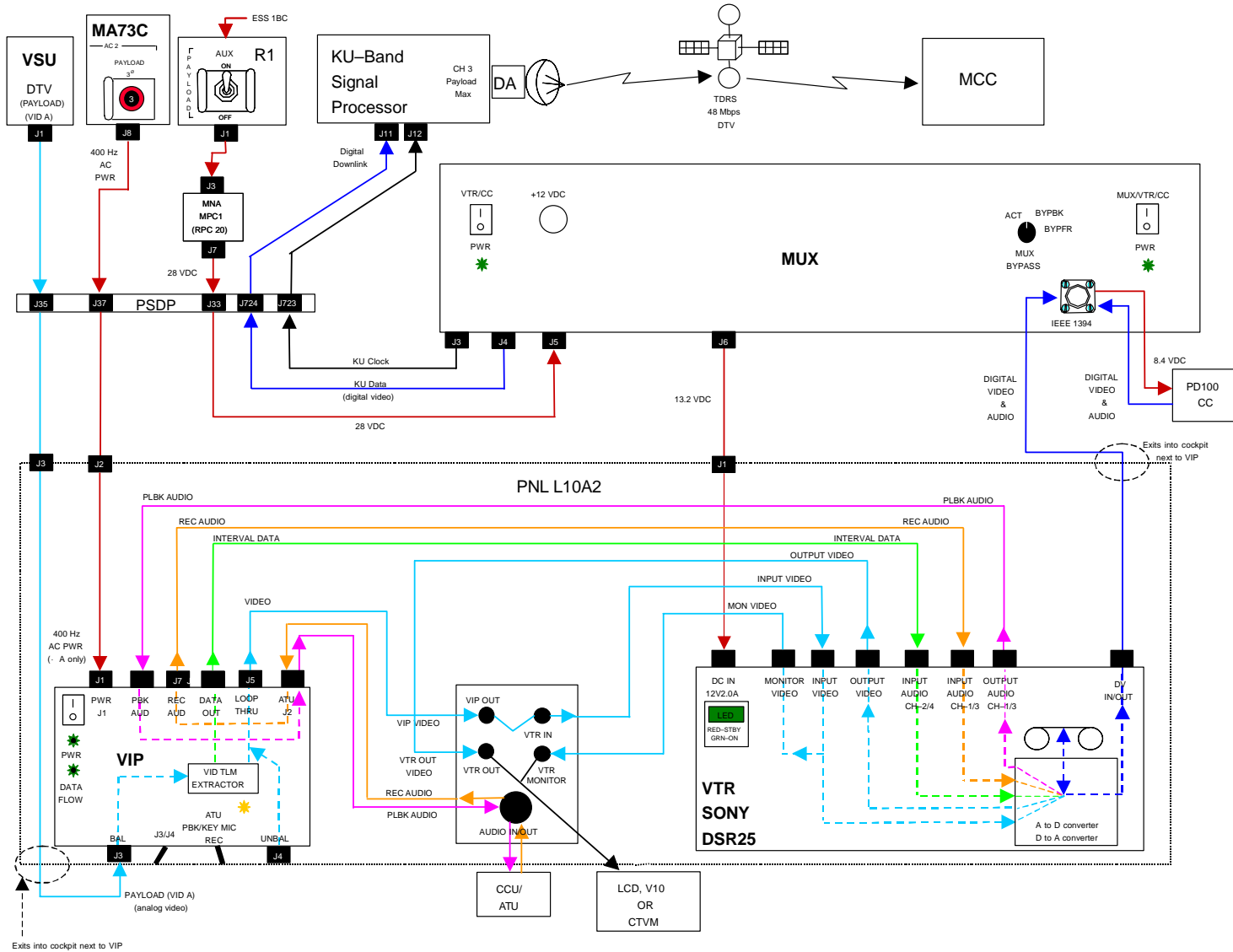

jsc48037\_118\_015.cvx

## DTV (Continued)

### VTR CLOCK SET

1. Activate VTR

R1            √PL AUX – ON

L10 (MUX)    VTR/CC PWR – on (LED on)  
(VTR)        √ON/STANDBY LED – green

2. Set VTR clock to GMT

DISPLAY SELECT – MENU

↓ pb – ETC, EXEC pb – push

↓ pb – CLOCK SET, EXEC pb – push

Use ↑,↓,EXEC to set Y,M,D,hr,min to GMT

DISPLAY SELECT – DATA

3. Deactivate VTR as reqd

(MUX)        ON/STANDBY pb – push (red LED on)  
              VTR/CC PWR – off (LED off)

## DTV (Continued)

### MALS

#### 12.1 NO VIDEO AT VTR OUT

- A7                   √Video Signal routed to VID OUT DTV pb
- MON 2                If using CTVM:  
                      √SOURCE – C
- R1                   √PL AUX – ON  
MA73C               √cb AC2 PL 3Φ – cl
- L10 (MUX)           √VTR/CC(MUX/VTR/CC) PWR – on (LEDs on); if not, go to MAL 12.3  
  (VIP)               √CCTV VIDEO IN – J3  
                      √PWR – on (LED on); if not, go to MAL 12.5  
                      √DATA FLOW LED – on; if not, go to MAL 12.6  
  
  (VTR)               √ON/STANDBY LED – green  
                      √INPUT SELECT – VIDEO  
  
                      If no joy, √MCC

#### 12.2 NO DIGITAL DNLK VIDEO AT MCC

- √Video from VTR MONITOR, if none, perform MAL 12.1  
                      √MCC has configured Ku Signal Band Processor CH3 for PL MAX
- L10 (MUX)           √MUX BYPASS – ACT
- L10 (MUX)           √IEEE 1394 male cable connected to IEEE 1394 port  
  (VTR)               DISPLAY SELECT – MENU  
                      ↓ pb – VTR, EXEC pb – push  
                      ↓ pb – DVEE OUT, √ON  
                      DISPLAY SELECT – DATA  
  
  (MUX)               √CHANNEL 3 DATA LED – on; if not, go to MAL 12.4  
  
                      If no joy, √MCC for possible IEEE 1394 male cable replacement



## DTV (Continued)

### MALS (Continued)

#### 12.3 MUX PWR LED(s) OFF

R1                   √PL AUX – ON

L10 (MUX)           √VTR/CC(MUX/VTR/CC) PWR – on (LEDs on)  
Notify MCC before proceeding  
√5 Amp Fuse (spare in DTV Fuse Kit)

If no joy, √MCC

#### 12.4 MUX CHANNEL 3 DATA LED OFF

√DTV MAL 12.2 complete

L10 (MUX)           If CHANNEL 3 1394,BUFF LEDs – on, signal not reaching MUX for processing  
(VTR)               | ON/STANDBY pb – push (red LED on)

L10 (MUX)           MUX/VTR/CC PWR – off, wait 5 sec, on  
(VTR)               | √ON/STANDBY LED – green  
If no joy:  
Repeat pwrndn per previous steps  
Disconnect,reconnect IEEE 1394 cable  
Repeat pwrup per previous steps

If no joy, √MCC

If only CHANNEL 3 1394 LED – on, MUX 1394 format error

| √MCC

If only CHANNEL 3 BUFF LED – on, MUX FIFO memory buffer error

√MCC

## DTV (Continued)

### MALS (Continued)

#### 12.5 VIP PWR LED OFF

MA73C           √cb AC2 PL 3Φ – cl

L10 (VIP)       √PWR – on  
                  Notify MCC before proceeding  
                  Pull VIP from container to check fuses  
                  √F1 5 Amp Fuse (spare in DTV Fuse Kit)  
                  √F2 2 Amp Fuse (spare in DTV Fuse Kit)

                  If no joy, √MCC

#### 12.6 VIP DATA FLOW LED OFF

MA73C           √cb AC2 PL 3Φ – cl

L10 (VIP)  
A7               √PWR – on  
                  √Video signal routed to VID OUT DTV pb  
                  √Video signal has Vertical Interval data (PLB Camrs)

L10 (VTR)       DISPLAY SELECT – AUDIO  
                  √CHANNEL 2 AUDIO LEVEL METER indicates signal  
                  If signal indicated, LED failed  
                  Notify MCC, continue Nom Ops  
                  DISPLAY SELECT – DATA  
(VIP)           PWR – off, then on (√DATA FLOW LED flashes twice)  
                  If LED does not flash twice, √MCC

## DTV (Continued)

### MALS (Continued)

#### 12.7 VTR ON/STANDBY RED LED OFF

R1                   √PL AUX – ON

L10 (MUX)           √VTR/CC(MUX/VTR/CC) PWR – on (LEDs on)  
Reset internal fuse by:  
VTR/CC(MUX/VTR/CC) PWR – off, wait 30 sec, on  
  
If no joy, √MCC

#### 12.8 VTR STARTS RECORDING OR REWINDS AND STARTS PLAYING AFTER MUX PWR APPLIED

Timer sw out of config

L10 (VTR)           √TIMER – OFF  
  
If no joy, √MCC

#### 12.9 VTR TAPE CONTROLS NOT FUNCTIONING (VTR DISPLAY INDICATES “ERR”)

Key Inhibit sw appears to be on

L10 (VTR)           √KEY INH – OFF  
  
If no joy, √MCC

#### 12.10 VTR DISPLAYS ERROR MSG 32

VTR has entered SAFE MODE

L10 (VTR)           ON/STANDBY pb – push (red LED on)  
(MUX)               VTR/CC,MUX/VTR/CC PWR – off (LEDs off), wait 10 sec, on (LED on)  
(VTR)               √ON/STANDBY LED – green  
√Error msg no longer displayed  
  
If no joy, √MCC

## **DTV (Concluded)**

### **MALS (Concluded)**

#### **12.11 VTR DISPLAYS ERROR MSG 21**

VTR has detected moisture inside

L10 (VTR)      Remove tape  
ON/STANDBY pb – push (red LED on)  
Leave for 1 hr before re-attempting pwr on  
Notify MCC

#### **12.12 VTR AUTOMATICALLY PWRS OFF**

VTR Auto Off feature on

L10 (VTR)      DISPLAY SELECT – MENU  
↓ pb – ETC, EXEC pb – push  
↓ pb – AUTO STBY, √Disable  
DISPLAY SELECT – DATA  
  
If no joy, √MCC

BPSMU

	<u>PAGE</u>	
BPSMU SPECIFICATIONS .....	13-2	'
BPSMU NOMENCLATURE .....	13-3	
BPSMU AUDIO/VIDEO .....	13-4	
DRAG THROUGH QD MATING .....	13-6	
DRAG THROUGH QD DEACTIVATION .....	13-8	
DRAG THROUGH QD NOMENCLATURE .....	13-9	

# BPSMU

## BPSMU

### BPSMU SPECIFICATIONS

#### BPSMU

INTEGRAL CABLE LENGTH: 8 ft  
RECOMMENDED MIC POSITION: Directly in front of mouth; 6 in. from mouth  
BATT: Two 9V (pwrs mic, not speaker; launched disconnected)  
BATT: 18V  
BATT LIFETIME: ~7-10 days  
BPSMU WEIGHT: 1.12 lb (w/batt)

#### BPSMU CABLES – DIRECT CCU CONNECTIONS

BPSMU TO CCU ADAPTER (1 ft): Adapts BPSMU integral cable to CCU  
BPSMU/ODS ADAPTER (4 in): Adapts 4 ft A/V Cable to CCU  
A/V CABLES (4 ft, 42 ft): Minimum A/V Cable config for audio ops

#### BPSMU CABLES – TV CONNECTIONS

A/V CABLES (4 ft, 22 ft, 44 ft, 35 ft, 42 ft) w/TVCU: Config for Camcorder thru ODS TV 1(2) port (TVCU assumes 125 ft of cable)  
BPSMU A/V PATCH CABLE (10 ft): Patches ODS TV Port audio into CCU using PRI(SEC) C/L port on VPU

# BPSMU (Continued)

## BPSMU NOMENCLATURE

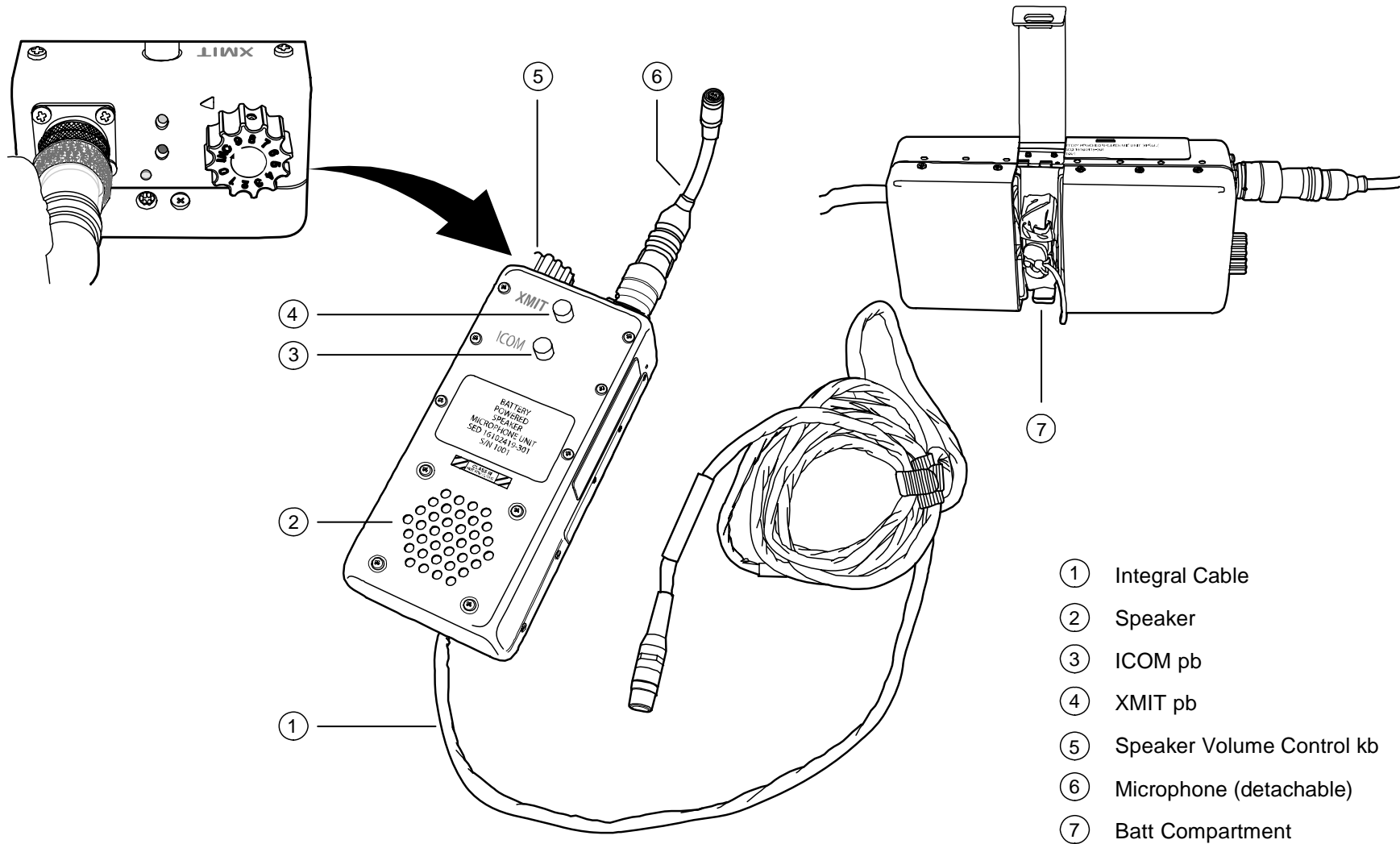

jsc48037\_068.cnv

# BPSMU (Continued)

## BPSMU AUDIO/VIDEO

- BPSMU L12 (SSP 2)**
1. Set up BPSMU, Safe ODS TV Port  
 Connect Batt  
 C/L CAM PWR – OFF  
  
 Config H/W per dwg at right
- CC**
2. Set up G1  
 Install Headset  
 Install Batt  
 ✓Wide Conversion Lens installed  
 ✓ND FILTER – OFF  
 ✓OUTPUT – CAM  
 ✓A/V1/V2 – V2  
 ✓...-  
 ✓STANDBY/LOCK – STANDBY  
 PWR dial – “green”   
 OPEN LCD  
 ✓Tape installed as reqd
- TVCU**
3. Config TVCU  
 CENTERLINE/CAMCORDER sw – CAMCORDER

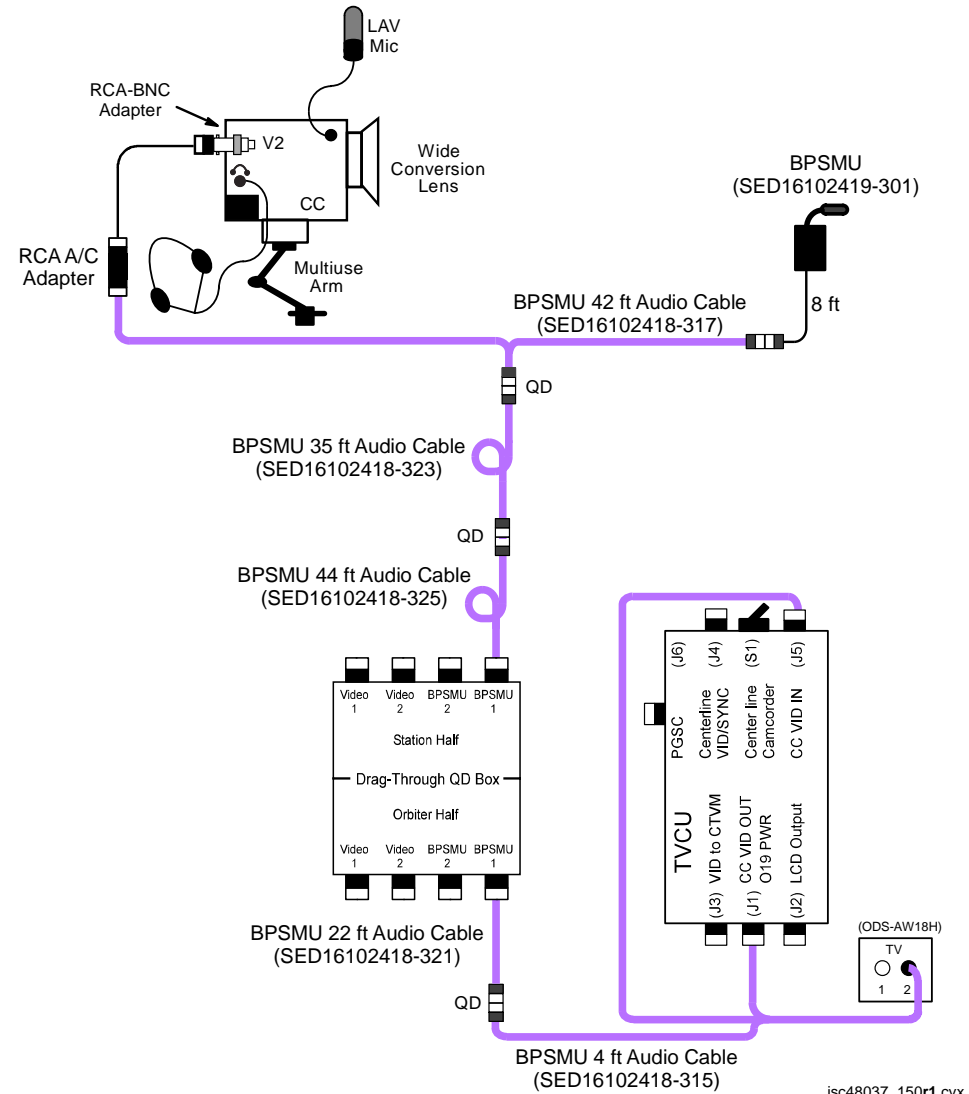



## BPSMU (Continued)

### BPSMU AUDIO/VIDEO (Concluded)

#### 4. Config TV System

Config H/W per dwg at right

R12 (VPU)

Green Jumper – SEC C/L  
 √VPU PWR – ON (LED on)

L12 (SSP2)

C/L CAM PWR – SEC ON

MON 1  
 A7

PWR – ON (LED on)  
 TV PWR CNTL – PNL  
     CONTR UNIT – MNA(B)  
     CNTL – CMD (wait 10 sec for system initialization)  
 VID OUT MON 1 pb – push  
 IN PL2(VPU) pb – push

MON 1

√CC video

O9

#### 5. Config Comm System

R AUD PWR – AUD/TONE  
 √MSTR VOL 1(2) – MAX  
 A/G 2,ICOM B – T/R (or loop as desired)  
 XMIT/ICOM MODE sel – PTT/PTT  
 VOL A/G 2,ICOM B tw – 8  
 Other Loops – OFF

Perform audio check w/BPSMU

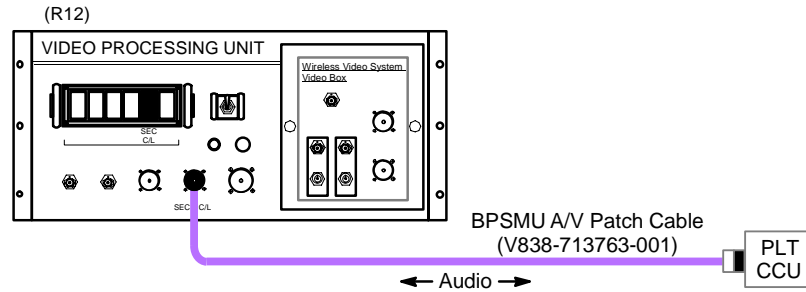

jsc48037\_151.cvx

## BPSMU (Continued)

### DRAG THROUGH QD MATING

#### NOTE

If activation of quick disconnect feature of the Drag Through QD reqd, both halves (station and orbiter) are to be mated using Alignment Tool

1. Disconnect cables from orbiter half of Drag Through QD. Disconnect cables from Station half as reqd
2. Inspect connectors, mating surfaces for debris or bent pins
3. Open access hole (rotate cw)

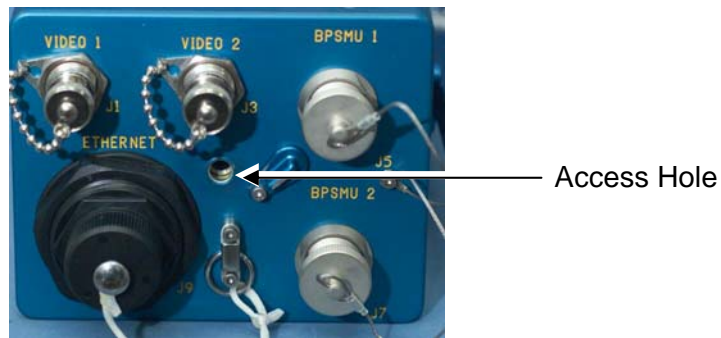

4. Remove Alignment Tool from Drag Through QD Handle Stowage (unthread ccw)
5. Place two Drag Through QD halves together, but not mated, and insert Alignment Tool into access hole



## BPSMU (Continued)

### DRAG THROUGH QD MATING (Continued)

6. Squeeze quick release levers together, rotate Alignment Tool cw (pressure may be needed to engage Alignment Tool threads on station half) until Alignment Tool reaches a soft stop

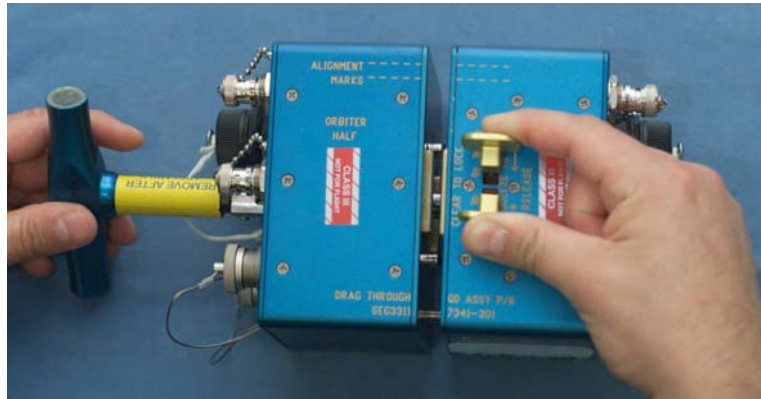

7. Release quick release levers, verify quick release levers in normal spread posn



8. Remove Alignment Tool (turn ccw)
9. Stow Alignment Tool in Drag Through QD Handle Stowage (turn cw)

## BPSMU (Continued)

### DRAG THROUGH QD MATING (Concluded)

10. Replace Alignment Tool on station half of Drag Through QD.



### DRAG THROUGH QD DEACTIVATION

1. Disconnect RWS cables (two) from orbiter side Video 1,2 ports. Stow on orbiter stbd ditch wall
2. Disconnect BPSMU cable from ODS CCU port 1 (coil as reqd)
3. Transfer Drag Through QD and remaining attached cables to ISS

## BPSMU (Continued)

### DRAG THROUGH QD NOMENCLATURE

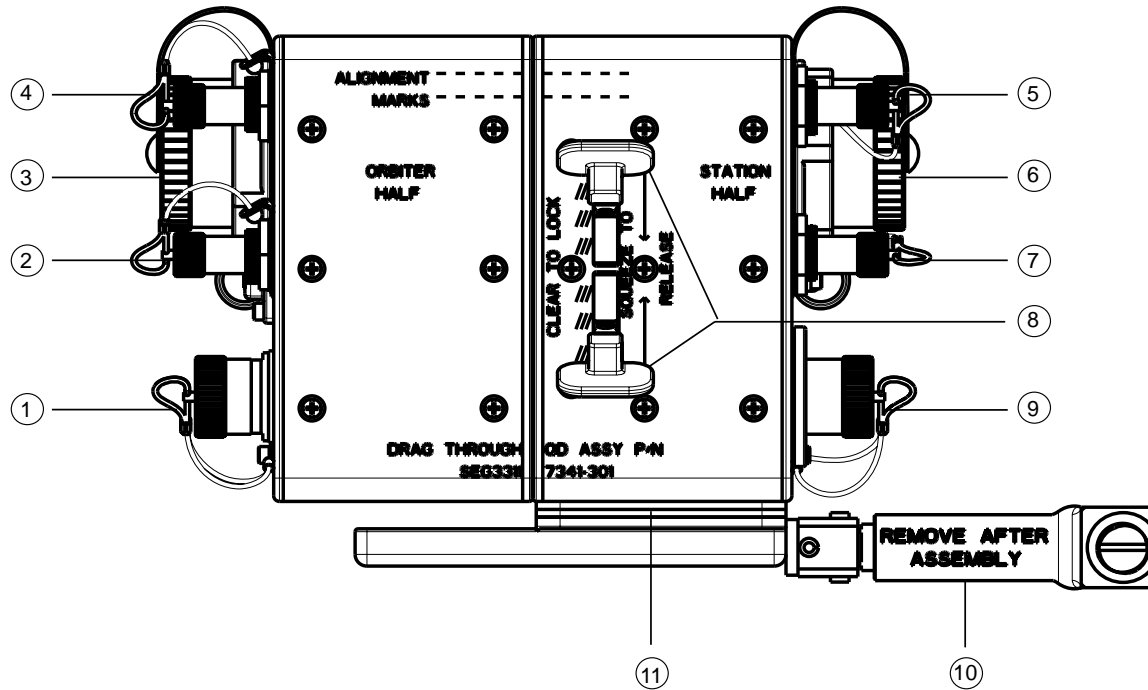

- ① BPSMU #1 (J5), BPSMU #2 (J7) directly below
- ② Video #2 (J3)
- ③ Ethernet (J9)
- ④ Video #1 (J1)
- ⑤ Video #1 (J2)
- ⑥ Ethernet (J10)

- ⑦ Video #2 (J4)
- ⑧ Quick Release Lever
- ⑨ BPSMU #1 (J6), BPSMU #2 (J8) directly below
- ⑩ Alignment Tool
- ⑪ Alignment Tool Holder

jsc48037\_121\_114.cvx

# BPSMU (Continued)

## DRAG THROUGH QD NOMENCLATURE (Continued)

STATION HALF

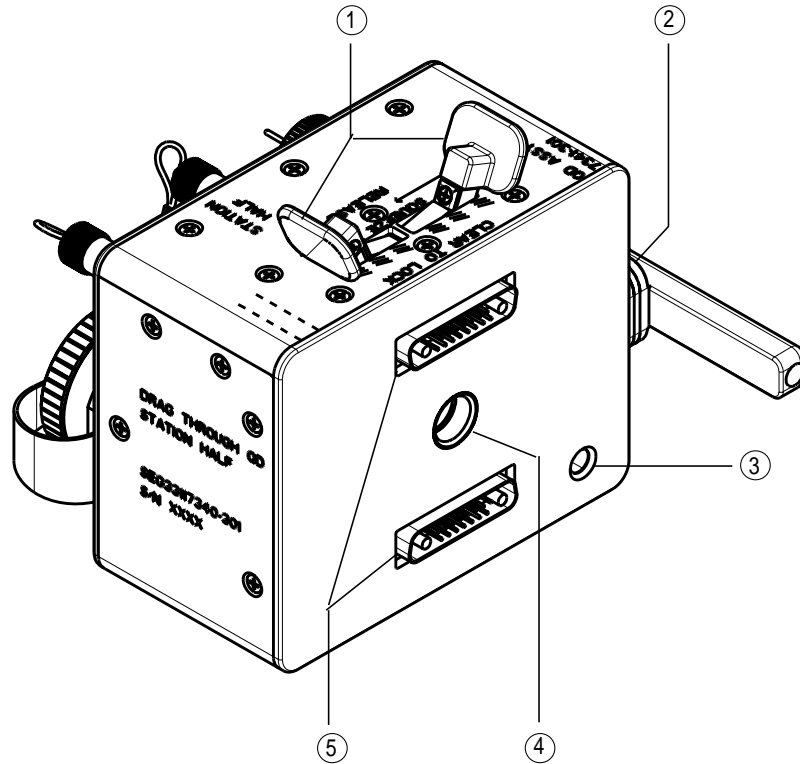

- ① Quick Release Lever
- ② Alignment Tool Holder
- ③ Alignment Pin Receptacle
- ④ Center Locking Pin Receptacle
- ⑤ DB25 Male Connector

ORBITER HALF

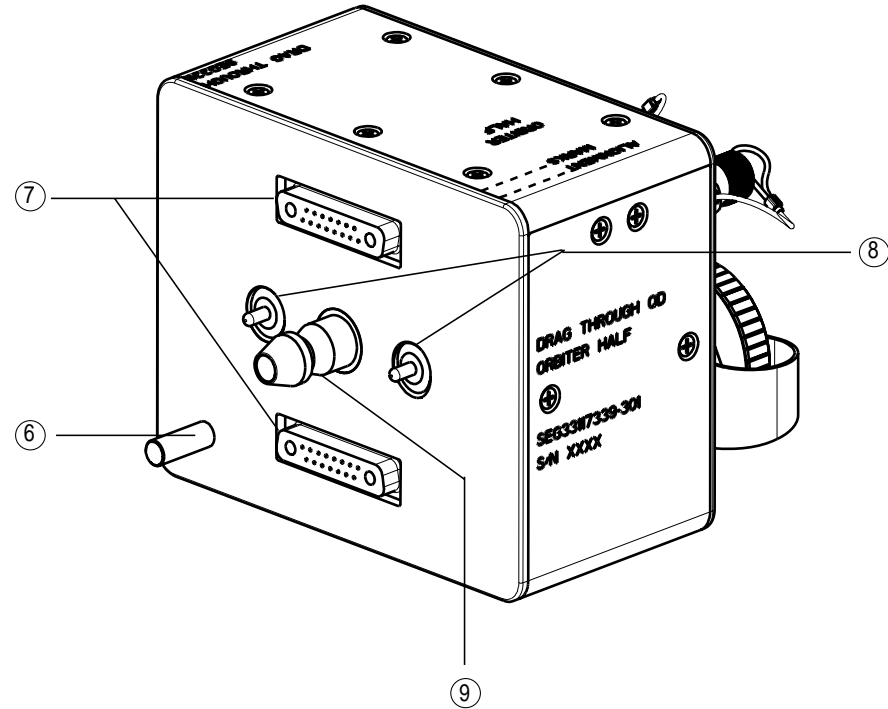

- ⑥ Alignment Pin
- ⑦ DB25 Female Connector
- ⑧ Ball Plunger
- ⑨ Center Locking Pin

jsc48037\_121\_115.cvx

# BPSMU (Concluded)

## DRAG THROUGH QD NOMENCLATURE (Concluded)

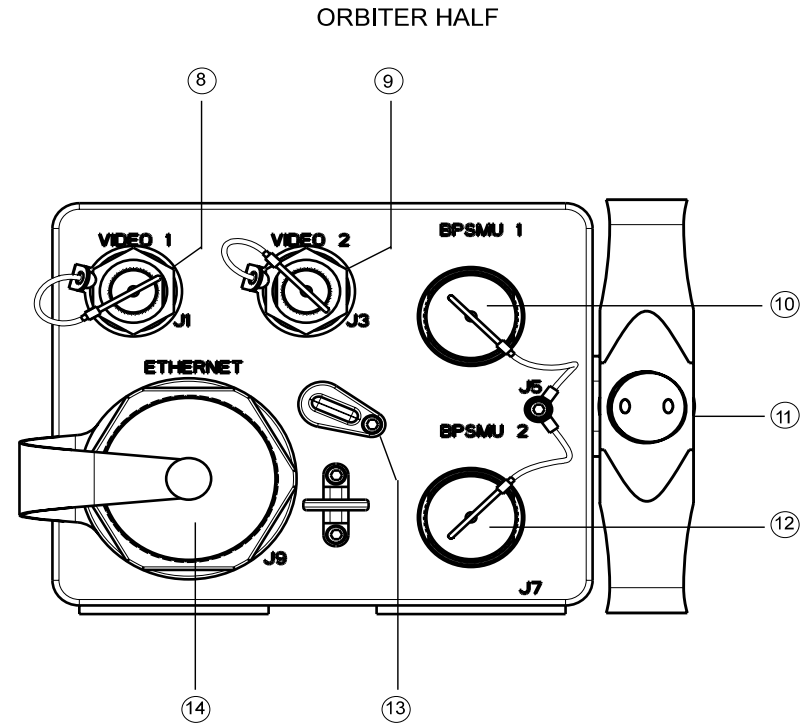
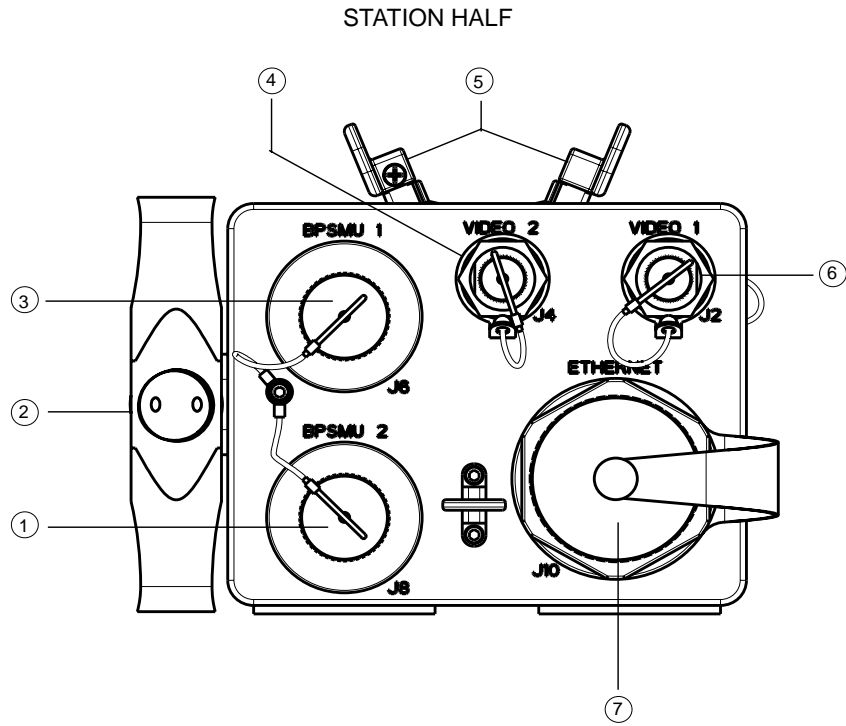

jsc48037\_121\_116.cvx

This Page Intentionally Blank



MINI-CAM

	<u>PAGE</u>
SPECIFICATIONS.....	14-2
LENS DATA.....	14-2
BRACKET DATA .....	14-2
NOMENCLATURE.....	14-3

**MINI-CAM**

**SPECIFICATIONS**

CAMR DIMENSIONS: 5 1/4 in (L) X 1 in (W) X 1 3/16in (D)  
 WEIGHT: 0.40 lb  
 IMAGER MODEL: XC-999  
 HORIZONTAL RESOLUTION: 470 lines  
 PIXEL COUNT: 768 Horizontal, 494 Vertical  
 SENSING AREA: 6.4mm Horizontal, 4.8mm Vertical, 8.0mm Diagonal  
 AVIUVOLTAGE: 12V  
 WEIGHT: 1.6 lb

**LENS DATA**

Lens	Aperture Range (f/stop)	Approximate Horizontal Field of View (FOV)	Minimum Focus Distance	Weight (lb)	Configuration Used
3.5mm	f/1.8-f/16	84.87°	Fixed	0.10	Glareshield, Aft Window
6.0mm	f/1.4-f/16	56.15°	0.3m	0.10	Aft Window
12.0mm	f/1.4-f/16	29.86°	0.5m	0.10	HUD
23.0mm	f/1.4-f/22	15.8°	0.2m	0.31	

**BRACKET DATA**

Bracket	Dimensions		Mount Type
	Length	Width	
Glareshield	9.5 in - 10.5 in	2 in	Velcro w/FDF Tether
Rear Window	12 in - 20 in	2 in	Velcro w/FDF Tether
HUD	4.5-in base 1.5-in extension 2-in rise	N/A	Thumbscrew w/Tie Wrap

# MINI-CAM (Concluded)

## NOMENCLATURE

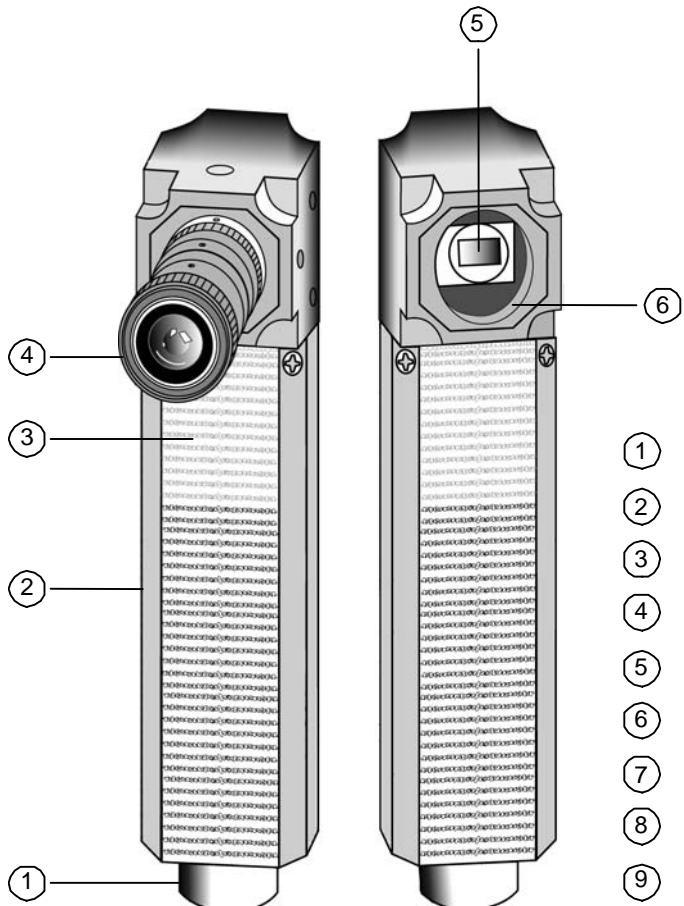

- ① Pwr/Video Connector
- ② Body (covered in Black Velcro hook)
- ③ Yellow Velcro (HUD Brkt)
- ④ Lens
- ⑤ CCD
- ⑥ Lens Mount
- ⑦ Threaded Mount
- ⑧ Aperture Ring
- ⑨ Focus Ring
- ⑩ Aperture Lock Nut

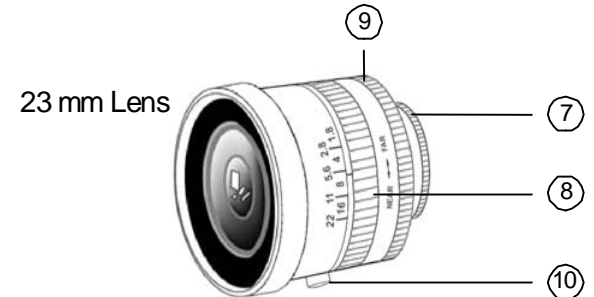
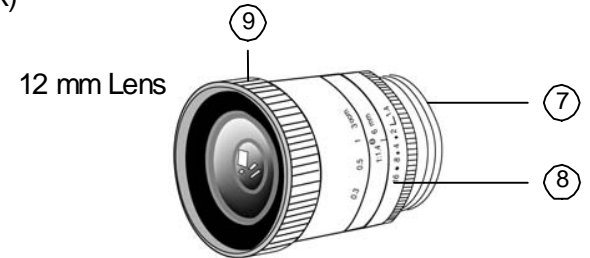
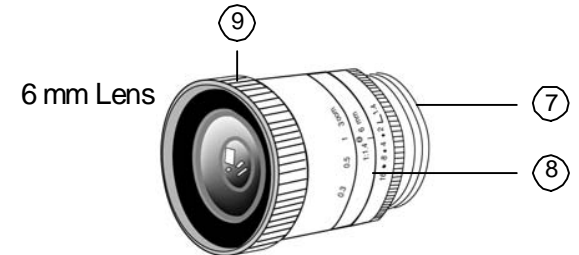

jsc48037\_071r2.cvx

This Page Intentionally Blank

WIRELESS VIDEO SYSTEM (WVS)

	<u>PAGE</u>
SPECIFICATIONS.....	15-2
NOMENCLATURE.....	15-4
RF CAMR ELECTRONICS.....	15-7
WVS PLB MOUNTED H/W.....	15-8
SOFTWARE – TOP STATUS AREA.....	15-9
SOFTWARE – RF CAMR PAGE.....	15-10
SOFTWARE – XCVR PAGE.....	15-12
SOFTWARE – TELEMETRY PAGE.....	15-14

**WIRELESS VIDEO SYSTEM (WVS)****SPECIFICATIONS**RF CAMR (aka EVA mobility unit Radio frequency Camr Assembly (ERCA))

MOUNTING INTERFACE: EVA helmet light structure

CAMRS: 3 per helmet

LENS FOCAL LENGTH:

LEFT: 6mm (56° HFOV) (mounted on left helmet light)

CENTER: 3.5mm (85° HFOV)

RIGHT: 12mm (30° HFOV) (mounted on right helmet light)

FOCUS CONTROL: FIXED at HYPERFOCAL

IRIS: MANUAL via PGSC

SHUTTER SPEED: AUTO(MANUAL)

GAIN CONTROL: AUTO(MANUAL) (0 to +6 dB)

WHITE BALANCE: AUTO(PRESET)

IMAGER:

MODEL: Sony XC-999

HORIZONTAL RESOLUTION: 470 lines

PIXEL COUNT: 768 Horizontal, 494 Vertical

SENSING AREA: 6.4mm Horizontal, 4.8mm Vertical, 8.0mm Diagonal

UHF RCVR ANTENNA: 1 (on top of helmet)

S-BAND XMTR ANTENNAS: 2 (on side of helmet light batts)

POWER: 12V from REBA batt enabled by pwr pb on right side of ERCA

OPERATING TEMP: -31 degC to +185 degC

PAYLOAD BAY TRANSCEIVERS (XCVR): 2 units

LOCATION: BAY 5 (under PLB liner)

OPS POWER: 28 VDC from A7/WIRELESS VIDEO POWER sw, Control Bus BC1

HTR POWER: 28 VDC from A7/WIRELESS VIDEO HEATER sw, Control Bus BC1

OPERATING TEMP: -190 degC to +210 degC

UHF PLB COMMAND ANTENNA: 1 unit

LOCATION: ODS TRUSS – AFT

## WIRELESS VIDEO SYSTEM (WVS) (Continued)

### SPECIFICATIONS (Concluded)

#### S-BAND RECEIVE ANTENNAS: Up to 7

LOCATIONS: 2 at BAY 1 PORT, STBD SILL  
2 at BAY 4 PORT, STBD SILL  
2 at BAY 11 PORT, STBD SILL  
1 at AFT BULKHEAD

POWER: 28 VDC from A7/WIRELESS VIDEO HEATER sw, Control Bus BC1

#### COMMAND LINK: UHF

FREQUENCY: 400 MHz  
EFFECTIVE BANDWIDTH: 12kHz  
BIT RATE: 9600 bps

#### TELEMETRY/VIDEO LINK: S-BAND

FREQUENCY: 2410 & 2470 MHz  
VIDEO BANDWIDTH: 16 MHz  
TELEMETRY BANDWIDTH: 5.8 & 6.8 MHz  
TELEMETRY BIT RATE: 9600 bps per channel  
RANGE: 300 ft reqd, 1100 ft expected (direct line-of-sight)

# WIRELESS VIDEO SYSTEM (WVS) (Continued)

## NOMENCLATURE

### RF CAMR MOUNTED TO EMU HELMET

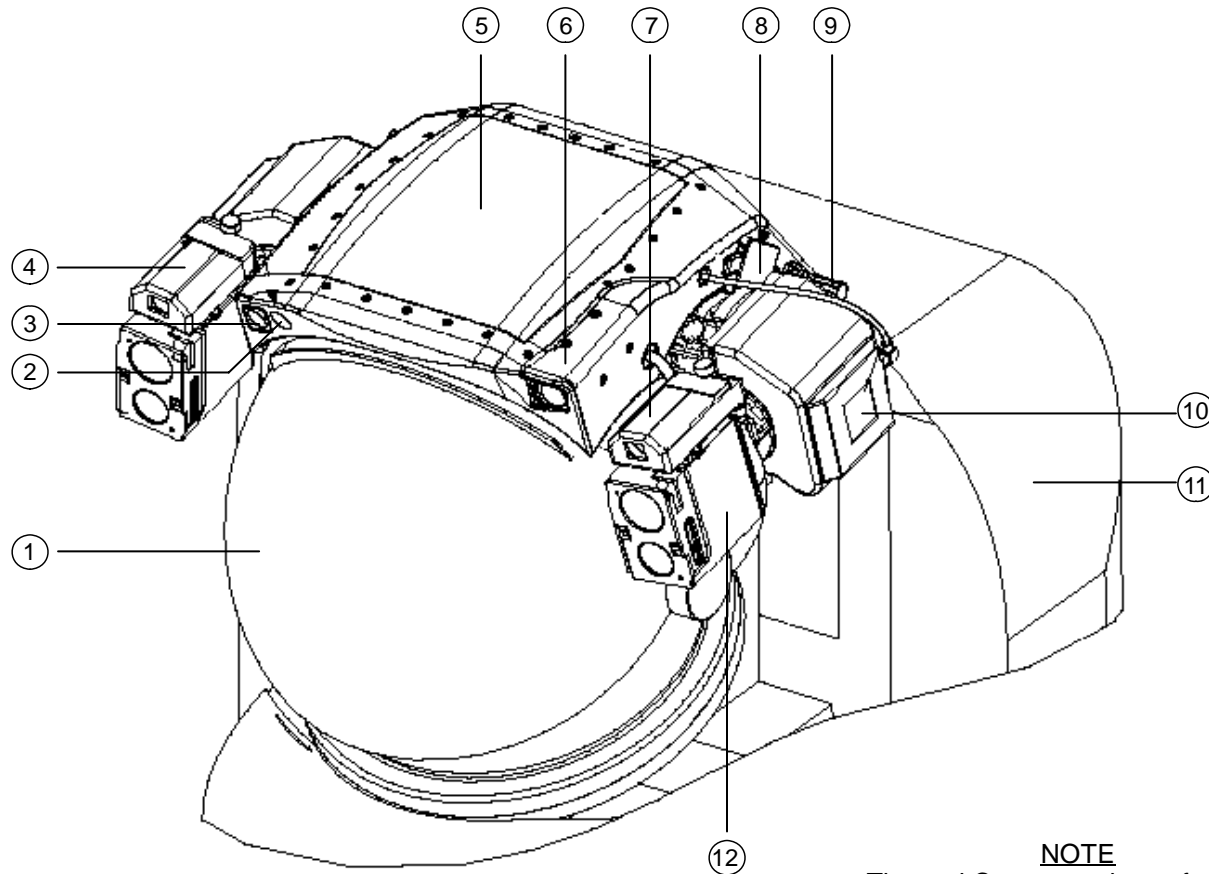

- ① EMU Helmet
- ② Pwr Indicator
- ③ Pwr sw
- ④ 12mm Lens
- ⑤ UHF Antenna
- ⑥ 3.5mm Lens
- ⑦ 6mm Lens
- ⑧ Latch (2X)
- ⑨ Pwr Receptacle
- ⑩ S-Band Antenna (2X)
- ⑪ PLSS
- ⑫ Helmet Light Module (2X)

**NOTE**  
Thermal Cover not shown for clarity

jsc48037\_075.cnv



# WIRELESS VIDEO SYSTEM (WVS) (Continued)

## NOMENCLATURE (Continued)

### RF CAMR MOUNTED TO EMU HELMET LIGHT

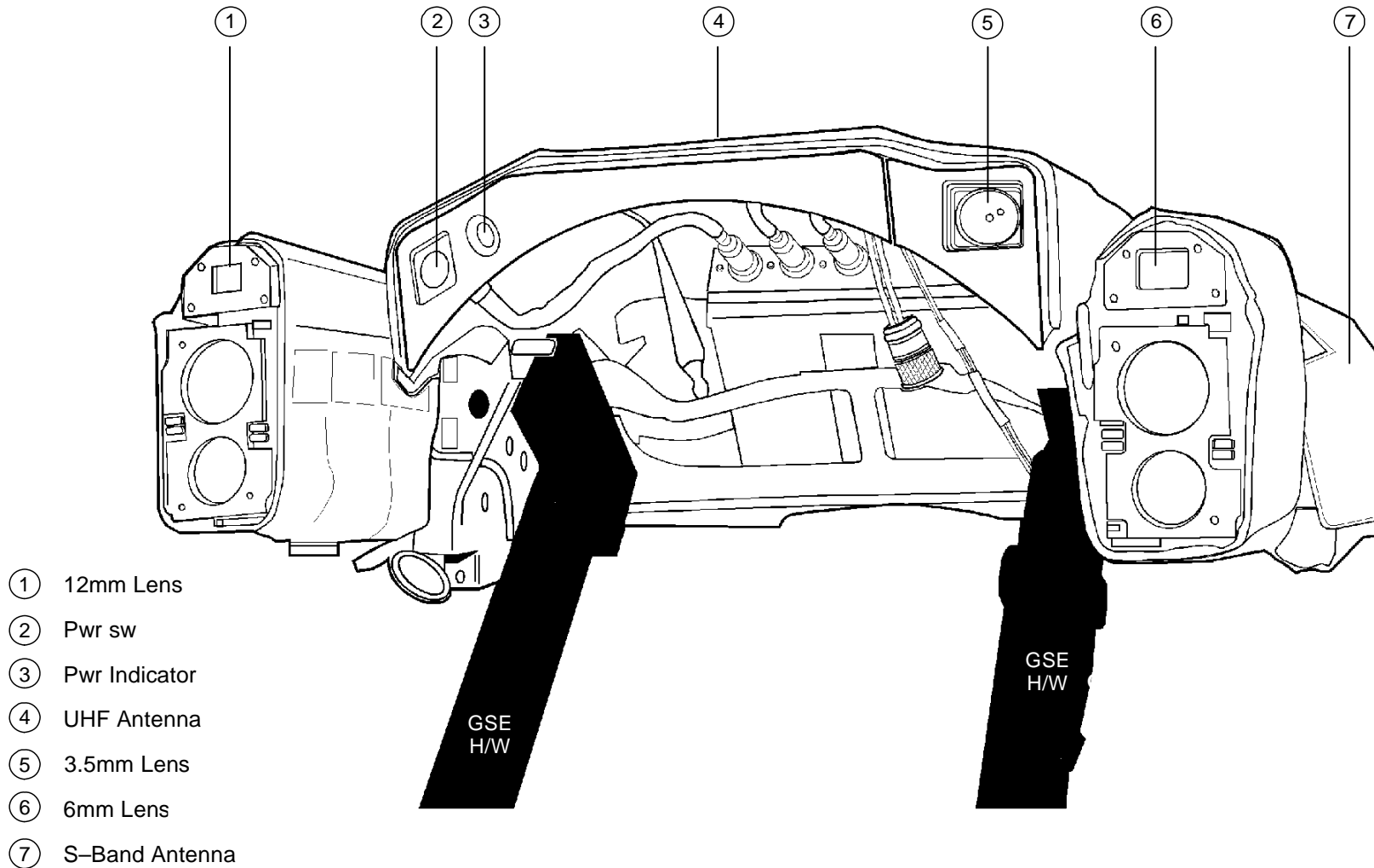

jsc48037\_076.cnv

**WIRELESS VIDEO SYSTEM (WVS) (Continued)**

**NOMENCLATURE (Concluded)**

**RF CAMR SHELL**

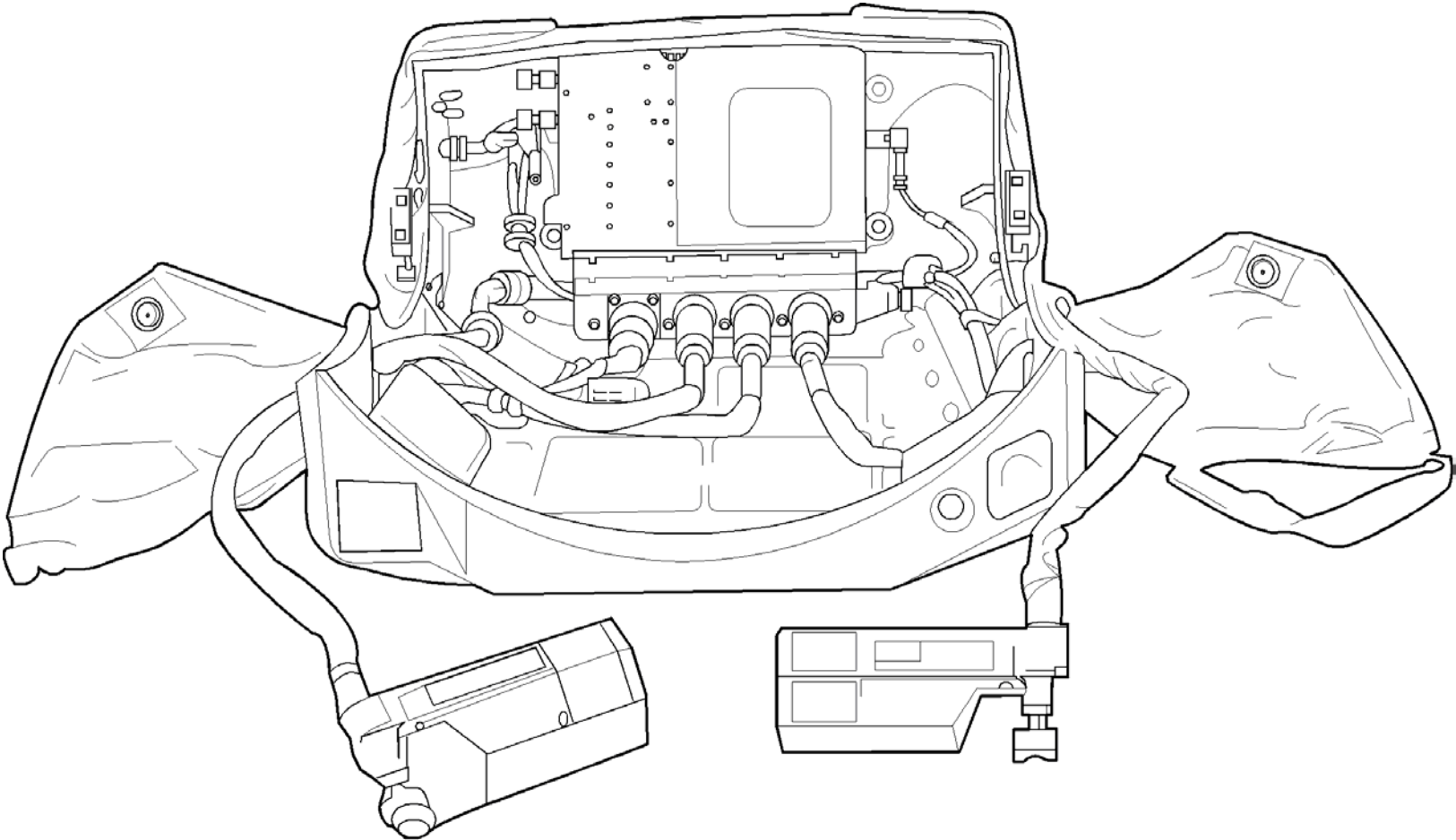

jsc48037\_077.cnv

# WIRELESS VIDEO SYSTEM (WVS) (Continued)

## RF CAMR ELECTRONICS

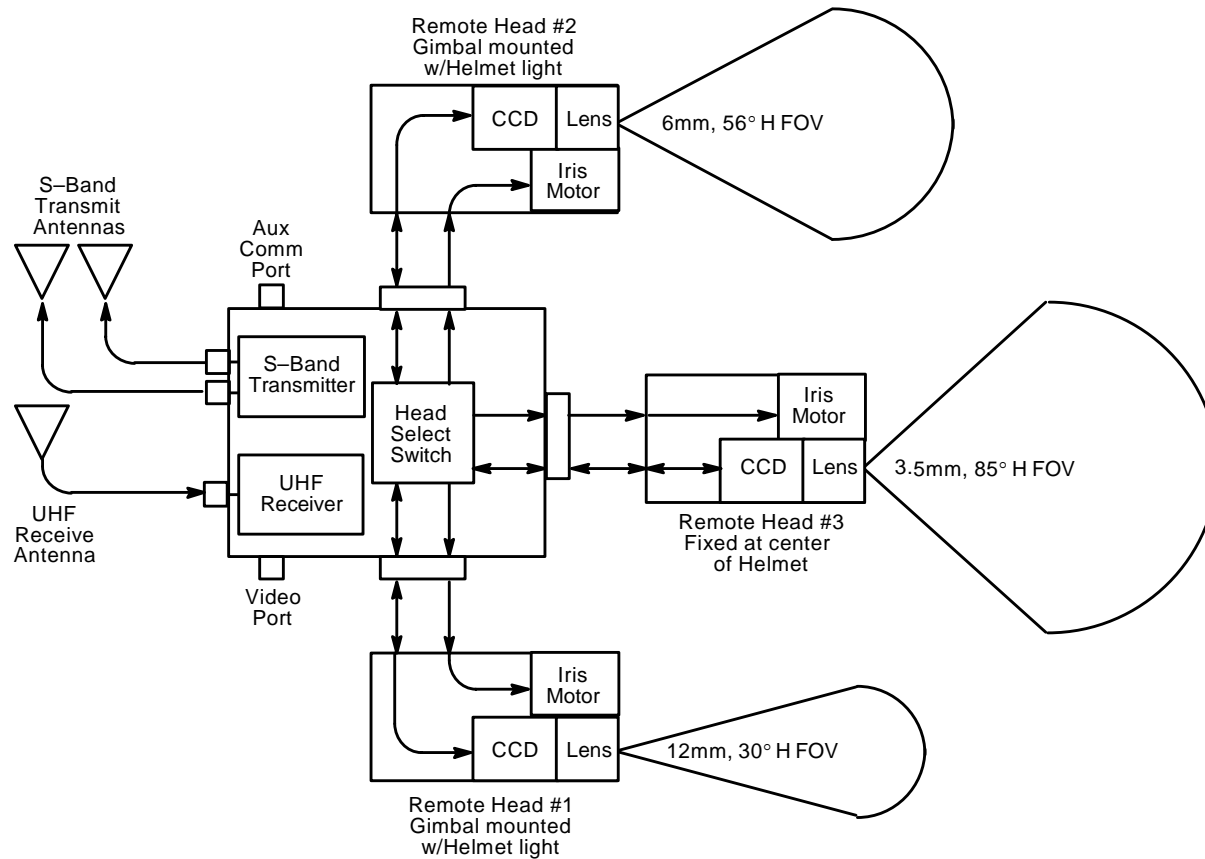

jsc48037\_078r2.cnv

## WIRELESS VIDEO SYSTEM (WVS) (Continued)

### WVS PLB MOUNTED H/W

- ① Aft Bulkhead Antenna
- ② Mid-Body S-Band Antennas
- ③ Transceivers
- ④ Mid-Body S-Band Antennas
- ⑤ Fwd S-Band Antennas
- ⑥ UHF Cmd Antenna

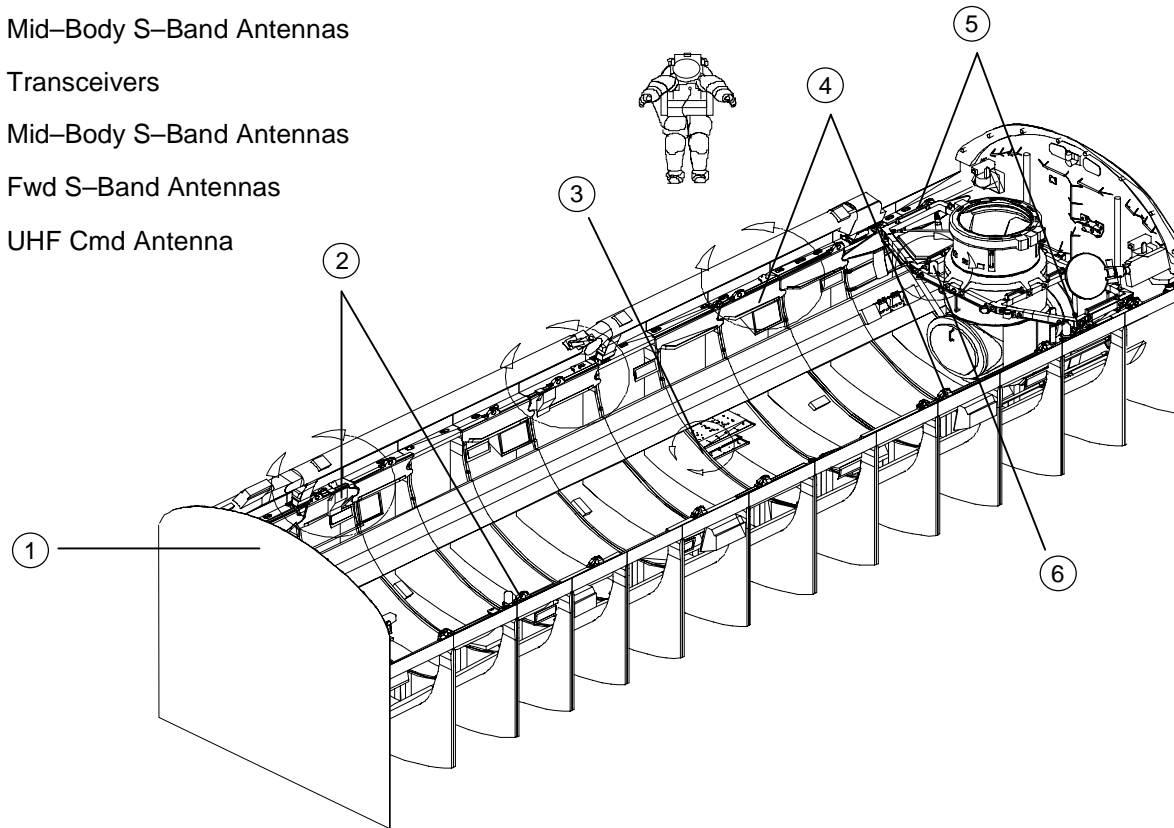

jsc48037\_079r1.cvx

## WIRELESS VIDEO SYSTEM (WVS) (Continued)

### SOFTWARE – TOP STATUS AREA

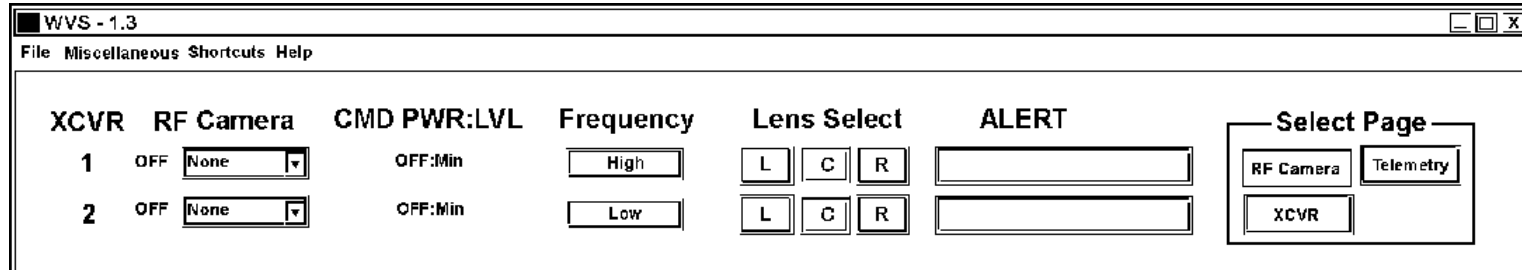

jsc48037\_080.cnv

RF CAMERA Status  
[ON/green / OFF/black]

RF Camr xmtr pwr status changes to ON when Camr selected (in pulldown menu)

RF CAMERA Pulldown

Selects/deselects Camr assignments to each PLB XCVR. RF Camrs will swap assignments if alternate assigned Camr selected

CMD PWR:LVL Status  
[OFF:Min(Max) / ON:Min(Max)]

Denotes which PLB XCVR is processing/sending cmds (ON/OFF). Displays cmd level (Min/Max)

Frequency Status/Cmd  
[High / Low]

Frequency that PLB XCVR is receiving S-Band signal from RF Camr. Will swap Camr assignments. Easiest way to swap Camr video coming from WIB connectors, recorders

Lens Select Cmd  
[L,C,R]

Selects operational lens. Default is Center

ALERT Msg Display

Displays error msgs generated by system. Msgs start off flashing/blue and change to static/black when acknowledged (clicked). "Temp Caution" msg will start off flashing/yellow until acknowledged. Msgs disappear when problem fixed. Highest priority error displayed first. Five available msgs:

Static XCVR

Loss of comm between PGSC, PLB XCVR

Static RF Camera

Loss of comm between XCVR, RF Camr

Bad Camera ID

Mismatch between RF Camr selected and RF Camr transmitting ID

Temp Alert

Displays when RF Camr(PLB XCVR) temp is 5° from going into caution range (ERCA = -35° to -30° C or +80° to +85° C, XCVR = -40° to -35° C or +80° to +85° C)

Temp Caution

Displays RF Camr(PLB XCVR) temp has gone out of limits (ERCA <-35° C or >+85° C, XCVR <-40° C or >+85° C)

Select Page Icons  
[RF Camera, XCVR, Telemetry]

Provides selection between the three displays

# WIRELESS VIDEO SYSTEM (WVS) (Continued)

## SOFTWARE – RF CAMR PAGE

The screenshot displays the 'WVS - 1.3' software interface with a menu bar (File, Miscellaneous, Shortcuts, Help) and a main control area. At the top, there are two rows of controls for RF Camera 1 and 2. Each row includes a status indicator (OFF), a dropdown menu (None), a power level control (OFF:Min), a frequency control (High/Low), lens selection buttons (L, C, R), and an ALERT input field. A 'Select Page' box on the right contains buttons for 'RF Camera', 'Telemetry', and 'XCVR'. Below these are two identical control panels for 'None' and 'C' camera modes. Each panel contains 'Lens Iris Control' (Close, Open buttons), 'Electronic Shutter' (Auto button), and 'White Balance Control' (Auto dropdown). A central 'Advanced Control' button is positioned between the two panels. At the bottom, there are two identical panels for 'Automatic Gain Control' (Disabled), 'Power' (ON, OFF, MUTE buttons), and 'S-Band Level' (Dynamic dropdown).

jsc48037\_081.cnv

## WIRELESS VIDEO SYSTEM (WVS) (Continued)

### SOFTWARE – RF CAMR PAGE (Concluded)

<u>Lens Iris Control</u> [Close,Open]	Opens(closes) Iris for selected lens. No telemetry other than video. Number displayed shows motor speed. Can click,hold
<u>Electronic Shutter Control</u> [Auto,Manual]	Brightens(darkens) image scene by controlling electronic shutter. Manual status runs from dark (0 = tbd sec) to bright (100 = 1/60 sec). Initial value = 50. Afterwards, setting stays where it was left
<u>White Balance Control</u> [Auto,2800K,6100K,Variable]	Determines how white balance set for Camr 2800K – PLB lights 6100K – Sunlight Variable – Allows red,blue gain control
<u>Automatic Gain Control</u> [Disabled,Enabled]	Controls status of AGC. Enabled needed for dark subjects; otherwise, it is disabled to reduce noise on video
<u>Power Status</u> [On,Off,Mute]	Status of RF Camr transmitter. Related to top status or RF Camr (black off, green on). Mute stops video signal from being sent to antenna
<u>S-Band Level</u> [Dynamic,Maximum]	Dynamic (default) – Pwr adjusted per signal strength seen at receiver (adjusted to be received at -40dB) Maximum – Sends signal at full pwr for signal strength problems
<u>Black Pedestal</u> [Increase,Decrease]	NOT USED. Brightness control varies from 0 to 100
<u>Zoom,Focus,LED Control</u>	NOT AVAILABLE. Future capabilities

# WIRELESS VIDEO SYSTEM (WVS) (Continued)

## SOFTWARE – XCVR PAGE

WS - 1.3  
File Miscellaneous Shortcuts Help

XCVR	RF Camera	CMD PWR LVL	Frequency	Lens Select	ALERT	Select Page
1	OFF <input type="text" value="None"/>	OFF:Min	<input type="text" value="High"/>	<input type="text" value="L"/> <input type="text" value="C"/> <input type="text" value="R"/>	<input type="text"/>	<input type="text" value="RF Camera"/> <input type="text" value="Telemetry"/>
2	OFF <input type="text" value="None"/>	OFF:Min	<input type="text" value="Low"/>	<input type="text" value="L"/> <input type="text" value="C"/> <input type="text" value="R"/>	<input type="text"/>	<input type="text" value="XCVR"/>

**Transceiver 1**

CMD Power

Antenna

**Transceiver 2**

CMD Power

Antenna

**Advance Controls**

**Chroma Stablizer**

IF

CMD Level

**Chroma Stablizer**

IF

CMD Level

jsc48037\_082.cnv



## WIRELESS VIDEO SYSTEM (WVS) (Continued)

### SOFTWARE – XCVR PAGE (Concluded)

CMD Power  
[OFF,ON]

Activates XCVR cmd processor. Only one XCVR can perform this duty. XCVR 1,2 selections are mutually exclusive and an ON cmd will automatically turn the other OFF. Status also shown under CMD PWR:LVL in top status area

Antenna  
[Auto,Manual]

Controls antenna selection method. Auto (default) picks antenna based on strongest signal strength. Manual provides antenna number selection. Antenna numbering sequence shown on WVS cue card

Chroma Stabilizer  
[On,Off]

NOT USED

Intermediate Frequency (IF)  
[Wide,Narrow]

Controls bandwidth sampled for RF Camr return signal. Changed to Narrow during signal strength troubleshooting

CMD Level  
[Min,Max]

NOT USED w/new spread spectrum XCVRs. Status shown under CMD PWR:LVL in top status area

# WIRELESS VIDEO SYSTEM (WVS) (Continued)

## SOFTWARE – TELEMETRY PAGE

WS - 1.3
File Miscellaneous Shortcuts Help

**XCVR**

1 OFF

2 OFF

**RF Camera**

OFF:Min

OFF:Min

**CMD PWR LVL**

High

Low

**Frequency**

L C R

L C R

**Lens Select**

L C R

L C R

**ALERT**

**Select Page**

RF Camera Telemetry

XCVR

RF Camera System Telemetry

RF Camera Lens	UHF		Power		Temperature (C)			
	Signal Strength	RX Good	Voltage	Amperes	Electronics	L	C	R
??? -1 M RM	-1.00 M	-1 M	0.00 M	0.00 M	32 M	32 M	32 M	32 M
??? -1 M RM	-1.00 M	-1 M	0.00 M	0.00 M	32 M	32 M	32 M	32 M

Transceiver Telemetry

	Temperature (C)	S Band			Power	
		Signal Strength	Antenna Select	Antenna Mode	Voltage	Amperes
XCVR 1	32 M	0.00 M	1 M	Manual M	10.00 M	10.00 M
XCVR 2	32 M	0.00 M	1 M	Manual M	10.00 M	10.00 M
Quads 1	1 0.0 M 2 0.0 M 3 0.0 M 4 0.0 M 5 0.0 M 6 0.0 M 7 0.0 M 8 0.0 M					
Quads 2	1 0.0 M 2 0.0 M 3 0.0 M 4 0.0 M 5 0.0 M 6 0.0 M 7 0.0 M 8 0.0 M					

jsc48037\_083.cnv

## WIRELESS VIDEO SYSTEM (WVS) (Concluded)

### SOFTWARE – TELEMETRY PAGE (Concluded)

#### RF Camr System Telemetry

RF CAMERA

Displays RF Camr title

Lens

Displays currently selected lens

[L,C,R]

UHF Signal Strength

Displays cmd link signal strength in dB seen at RF Camr

[nom = -120 to -59]

UHF RX Good

NOT USED

Pwr Voltage

Displays RF Camr system voltage

[nom = 12.8]

Pwr Amperes

Displays RF Camr system current

[nom = 0.40]

Temperature Electronics

Displays RF Camr electronics temp in degC. Alert range = -30° to -35° C and +80° to +85° degC. Caution range = <-35° and >+85° degC

[nom = 13 to 30]

Temperature L,C,R

Displays RF Camr left Camr temp in degC. Alert range = -30° to -35° C and +80° to +85° C. Caution range = <-35° C and >+85° C

[nom = 0 to 33]

#### Transceiver Telemetry

XCVR 1,2 Temperature

Displays XCVR temp in degC. Alert range = -40° to -35° C and +80° to +85° C. Caution range = <-40° and >85° C

[nom = 18 to 37]

S-Band Signal Strength

Displays return signal strength seen at XVCR in dB

[nom = 97.5 to -10.5]

S-Band Antenna Select

Displays which S-Band antenna the XCVR is using to get video signal

S-Band Antenna Mode

Displays XCVR antenna selection mode

[Auto,Manual]

Power Voltage

Displays XCVR system voltage

[nom = 12.42]

Power Amperes

Displays XCVR system current

[nom = 1.10]

Quads 1,2

Displays current signal strength for each XCVR's selected S-Band antenna in dB showing strongest of antenna quads

This Page Intentionally Blank

SEQUENTIAL STILL VIDEO (SSV)

	<u>PAGE</u>
SPECIFICATIONS.....	16-2
NOMENCLATURE.....	16-2
TEST PATTERN VIA SSV.....	16-3
SSV TLM DNLK.....	16-3
SSV DEACTIVATION.....	16-4
MALS.....	16-5
16.1 PWR LED NOT LIT.....	16-5
16.2 FRONT PANEL LEDs NOT INDICATING CORRECTLY.....	16-5

# SSV

## SEQUENTIAL STILL VIDEO (SSV)

### SPECIFICATIONS

DIMENSIONS: 8.5 in (L) x 4.245 in (W) x 2.72 in (H)  
 PWR: 28V  
 FUSE: 2A  
 WEIGHT: 3.02 lb

### NOMENCLATURE

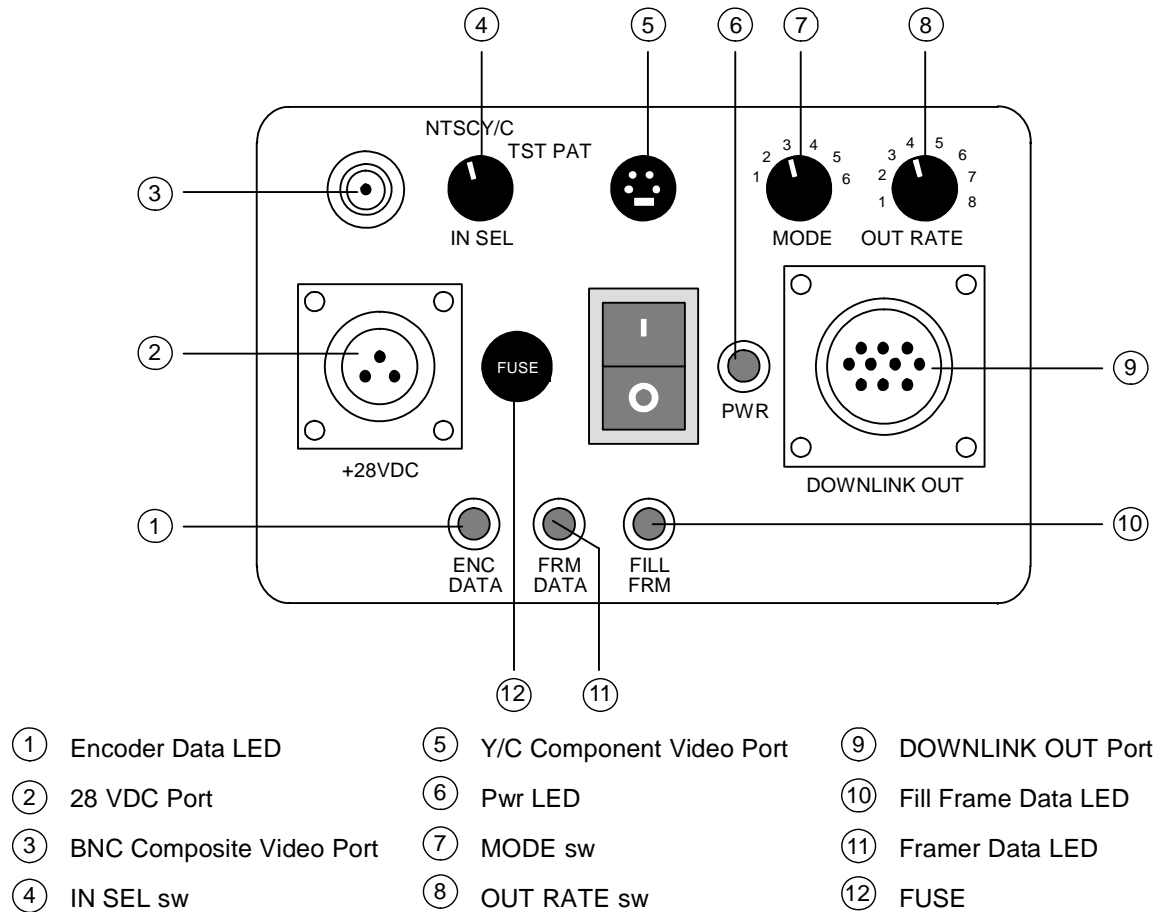

### TOP DECAL

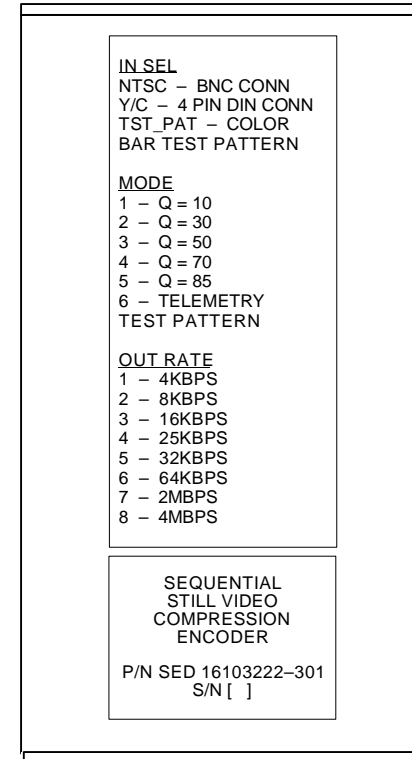

jsc48037\_085.cnv

## SEQUENTIAL STILL VIDEO (SSV) (Continued)

### TEST PATTERN VIA SSV

1. Perform SSV NOMINAL SETUP, step 1 (PHOTO/TV FS, SCENES)
2. SSV Settings
  - IN SEL – TEST PAT
  - Mode – 3 (may change if desired)
  - OUT RATE per FLIGHT PLAN
  - SSV Pwr – ON
  - √Pwr LED illum
  - √ENC DATA LED flickering
  - √FRM DATA LED flickering
  - √FILL FRM pulsing

### SSV TLM DNLK

1. Perform SSV NOMINAL SETUP, step 1 (PHOTO/TV FS, SCENES)
2. SSV Settings
  - IN SEL – NTSC
  - Mode – 6
  - OUT RATE per FLIGHT PLAN
  - SSV Pwr – ON
  - √Pwr LED illum
  - √ENC DATA LED flickering
  - √FRM DATA LED flickering
  - √FILL FRM pulsing

## SEQUENTIAL STILL VIDEO (SSV) (Continued)

### SSV DEACTIVATION

1. SSV  
SSV Pwr – off
    - √Pwr LED not illuminated
    - √ENC DATA LED not illuminated
    - √FRM DATA LED not illuminated
    - √FILL FRM LED not illuminated
- L11  
(PDIP 2)
2. TV System  
Go to DEACTIVATION (Cue Card, TV) as reqd



## SEQUENTIAL STILL VIDEO (SSV) (Concluded)

### MALS

#### 16.1 PWR LED NOT LIT

√Fuse  
Replace fuse if blown w/fuse from SSV Fuse Kit  
(SED 15500338-301)

√DC Pwr from orbiter util

#### 16.2 FRONT PANEL LEDs NOT INDICATING CORRECTLY

Cycle pwr on SSV Compression Encoder  
SSV Pwr – 0 (off)  
Wait 5 sec  
SSV Pwr – 1 (on)

√Cables  
√Video source

This Page Intentionally Blank

BINOCULARS

PAGE

SPECIFICATIONS..... 17-2

## BINOCULARS

### BINOCULARS

#### SPECIFICATIONS

Model	Stabilization	Pwr	Magnification	Objective Lens (mm)	Exit Pupil	Approx FOV	Approx Linear FOV @ 1000 yd	Approx Minimum Focus (ft)	Weight (lb)
Zeiss 8 X 20	No	N/A	8X	20	2.5mm	6.6°	346.5 ft	9.0	0.39
Fuji 10 X 40 Day/Night	Yes (Gyro)	6AA	10X	40	4.5mm	5.0°	210.0 ft	65.0	5.5
Fuji 14 X 40	Yes (Gyro)	6AA	14X	40	2.8mm	4.0°	210.0 ft	75.0	4.6
Fuji 16 X 70	No	N/A	16X	70	4.4mm	4.0°	210.0 ft	100.0	4.76
Zeiss 20 X 60	Yes (Mechanical)	N/A	20X	60	3.0mm	2.9°	150.0 ft	50.0	3.66

FIBERSCOPE

	<u>PAGE</u>
SPECIFICATIONS.....	18-2
NOMENCLATURE.....	18-2
ACTIVATION/OPERATION .....	18-3
DEACTIVATION .....	18-3
FIBERSCOPE LIGHT PWRUP (30 min) .....	18-4
FIBERSCOPE LENS REPLACEMENT .....	18-6

# FIBERSCOPE

## FIBERSCOPE

### SPECIFICATIONS

LIGHT PWR: Orbiter – 6V via IFM Breakout Box

### NOMENCLATURE

Lens Tip Adapter (FOV in deg)
10D
20D
40D
40S (Rt angle Lens)
80D

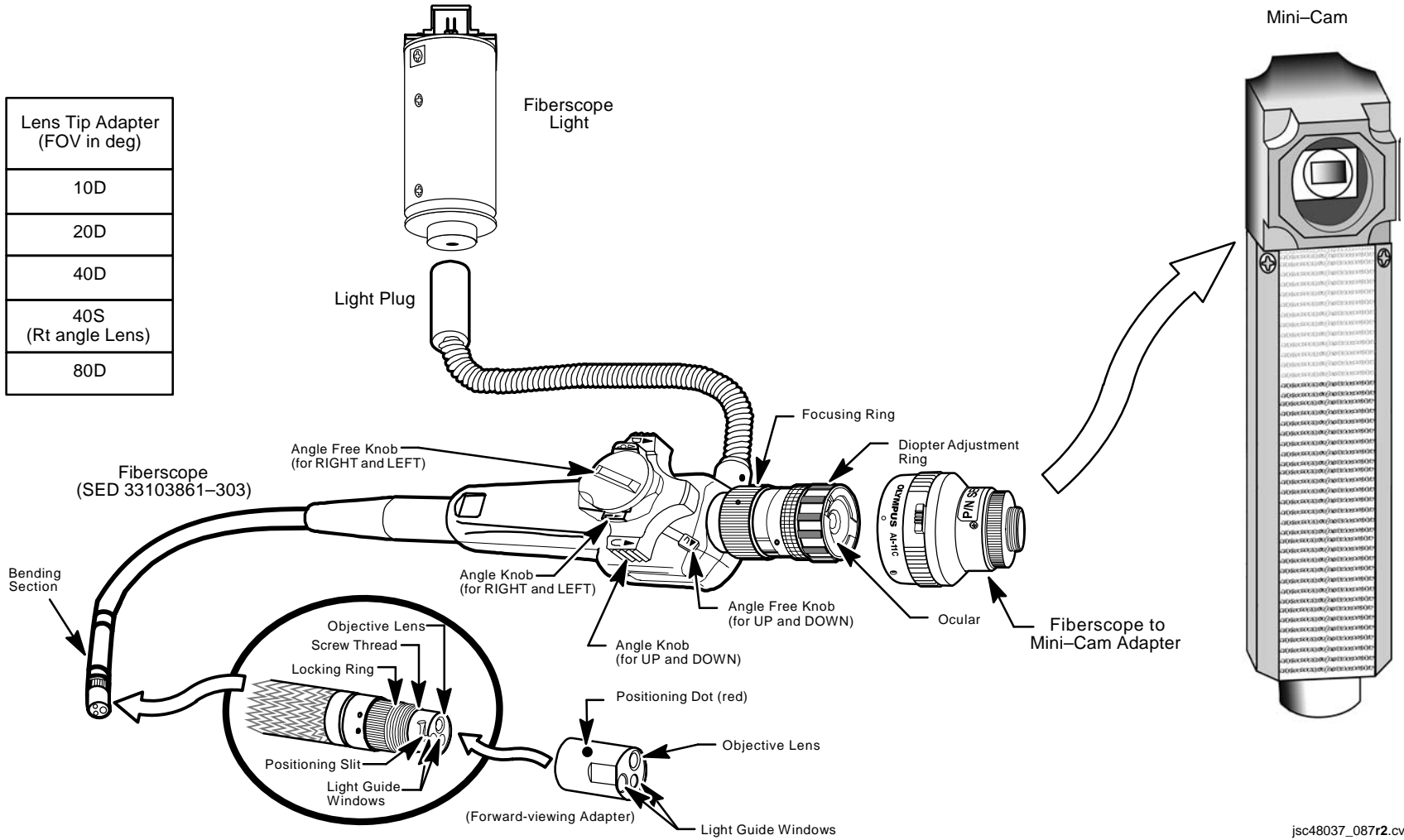

jsc48037\_087r2.cvx

## FIBERSCOPE (Continued)

### ACTIVATION/OPERATION

- MA9N
1. Unstow Fiberscope Kit, Fiberscope Light, if reqd
  2. If Fiberscope Light reqd:  
Install Fiberscope Light Plug into Fiberscope Light  
Perform FIBERSCOPE LIGHT PWRUP, 18-4, steps 1 thru 12
  3. If installed lens not desired:  
Unstow spare lens  
Perform FIBERSCOPE LENS REPLACEMENT, 18-6
  4. If video dnlk(viewing) reqd:  
Unstow Fiberscope-to-Mini-Cam Adapter  
Screw Adapter into Mini-Cam body lens mount  
Mount Adapter to Fiberscope by aligning setter pin w/orange dot, rotate Adapter cw to lock  
Perform IN-CABIN MINI-CAM (MINI-CAM)  
Route Mini-Cam video to monitor or dnlk:  
A7 VID OUT MON 1(2) (DNLK) pb – push  
IN FLT DECK(MIDDECK) pb – push  
Push button on Adapter and rotate Fiberscope until slit mark on image edge at top of image  
OR  
Unstow,install Fiberscope Eyepiece
  5. Adjust diopter until slit mark clearly visible  
Adjust Camr viewing by rotating up/down,left/right angle knobs while free knobs are in F posn  
Adjust focus by rotating focus ring

### DEACTIVATION

1. If Fiberscope Light used:  
Perform FIBERSCOPE LIGHT PWRUP, 18-4, steps 13 thru 15  
Remove Fiberscope Light from Fiberscope Light Plug  
Stow Fiberscope Light
2. If Mini-Cam used:  
O19(MO58F) TV PWR – OFF  
Remove Mini-Cam Adapter from Fiberscope  
Remove,stow Mini-Cam Adapter from Mini-Cam body
3. Remove,stow Fiberscope Eyepiece
4. Stow Fiberscope, Fiberscope Kit

## FIBERSCOPE (Continued)

### FIBERSCOPE LIGHT PWRUP (30 min)

1. Unstow:
    - Multimeter
    - Pin Kit (two 5-in 20 ga Pin/Pin Test Jumper Leads, two 24-in Minigrabbers, 5-Amp Fuse)
    - Gray Tape
    - IFM Breakout Box
    - DC Pwr Cable
  - MA9N 2. Remove Battery Holder Assembly from Fiberscope Light
  - MO52J 3. √DC UTIL PWR MNA – OFF
  4. a. Config Breakout Box:
    - AUX – OFF
    - 28V/VAR VOLT – VAR VOLTS
    - PWR A,B – OFFb. Remove fuse cap from side A
  - c. Rotate GA SEL A – 20
  - d. Install 5-Amp Fuse, replace cap
5. Assemble Breakout Box and Multimeter as shown below

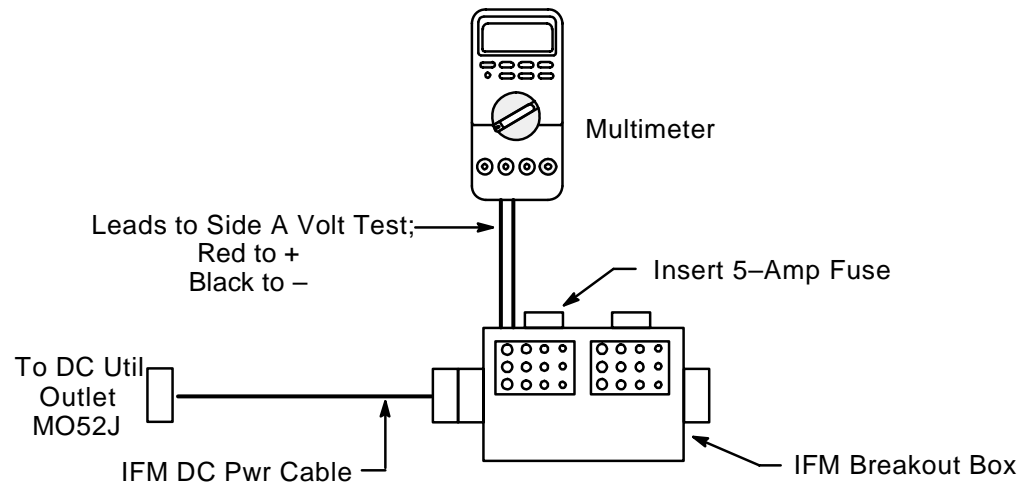

jsc48037\_088.cnv



## FIBERSCOPE (Continued)

### FIBERSCOPE LIGHT PWRUP (30 min) (Continued)

6. Configure Multimeter for DC V (auto range)
- MO52J 7. DC UTIL PWR MNA – ON
8. Breakout Box:  
√VAR VOLTS – ON (It on)
9. Set VAR VOLTS output by rotating VAR rotary sw until Multimeter reads 6 VDC

#### NOTE

Positive, negative leads from Breakout Box can be attached to either terminal on Fiberscope Light

10. Install Breakout Box and cables to Fiberscope Light as shown below

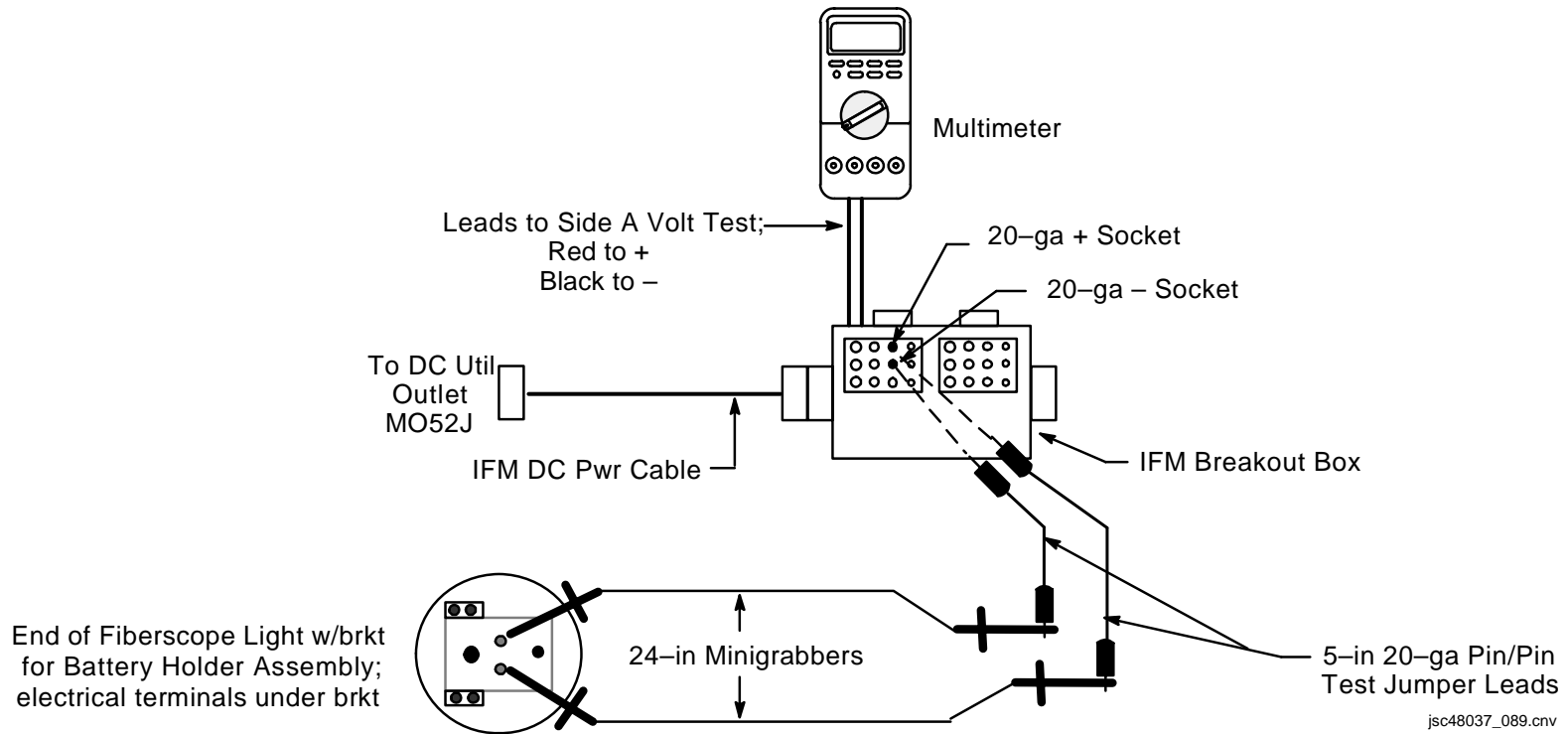

## **FIBERSCOPE (Concluded)**

### **FIBERSCOPE LIGHT PWRUP (30 min) (Concluded)**

11. Secure IFM Breakout Box, Multimeter, and PWR Cable in convenient location
12. When ready to operate Fiberscope:  
Breakout Box: PWR A – ON (It on)
13. When finished operating Fiberscope:  
Breakout Box: PWR A – OFF
- MO52J 14. DC UTIL PWR MNA – OFF
15. √Disconnect Minigrabbers, Test Jumper Leads, Multimeter, and IFM DC Pwr Cable

### **FIBERSCOPE LENS REPLACEMENT**

1. Unscrew lock ring from lens until second threads disengage
2. Rotate lens to align green dots
3. Pull lens to engage first threads, unscrew lock ring until lens free
4. Select desired lens and stow removed lens in foam
5. Align green dots on lens and Fiberscope; slowly push lens on until lens stops against first threads; screw on lens until first threads disengage
6. Rotate lens until green dot aligns w/Fiberscope red dot
7. Push lens into Fiberscope until it stops against second threads, screw on lens until second threads fully engaged

LASER DYNAMIC RANGE IMAGER (LDRI)

	<u>PAGE</u>
SPECIFICATIONS.....	19-2
NOMENCLATURE.....	19-3
OBSS PTU PAN AND TILT RANGES .....	19-5
FUNCTIONAL FLOW .....	19-6
ITVC, LDRI, AND PTU INTERACTIONS .....	19-7
OPP PANEL .....	19-8
OBSS PANEL .....	19-9
A7 PANEL.....	19-10
MONITOR INDICATIONS FOR LDRI VIDEO.....	19-11

## LASER DYNAMIC RANGE IMAGER (LDRI)

### SPECIFICATIONS

CAMERA MODEL: Sony XC-ST70  
PIXEL COUNT: 720 x 480  
CAMERA SENSOR FOV: 15 x 19.7 deg  
FOCAL LENGTH: 50.6mm  
IRIS: Fixed at F11  
FOCUS: Fixed at 6 ft

LASER MODEL & TYPE: LaserTeILT-1110-20W-CS, Class IV rated @ 20W and limited to 11W  
LASER WAVELENGTH: 805 nm +/- TBD based upon laser temperature  
LASER COVERAGE: 23.7 (vertical) x 19.9 deg (horizontal)  
CAMERA/LASER PARALLAX: Approx 1.5 in horizontal  
HAZARD ZONE: 9 ft

MOUNTING INTERFACE: Bottom of ITVC (ITVC specifications in CCTV section)  
POINTING CAPABILITY: Standard Pan Tilt Unit (PTU)  
PAN RANGE: 179.8 deg  
TILT RANGE: 300 deg  
ITVC ILLUMINATOR: LDRI

WEIGHT: 6.5 lb + 3 lb counter-weight  
DIMENSION: 11 in (L) x 5.88 in (W) x 4.0 in (H)  
PWR: 28V +/- 4V

# LASER DYNAMIC RANGE IMAGER (LDRI) (Continued)

## NOMENCLATURE

### NOTE

Thermal covers are not depicted

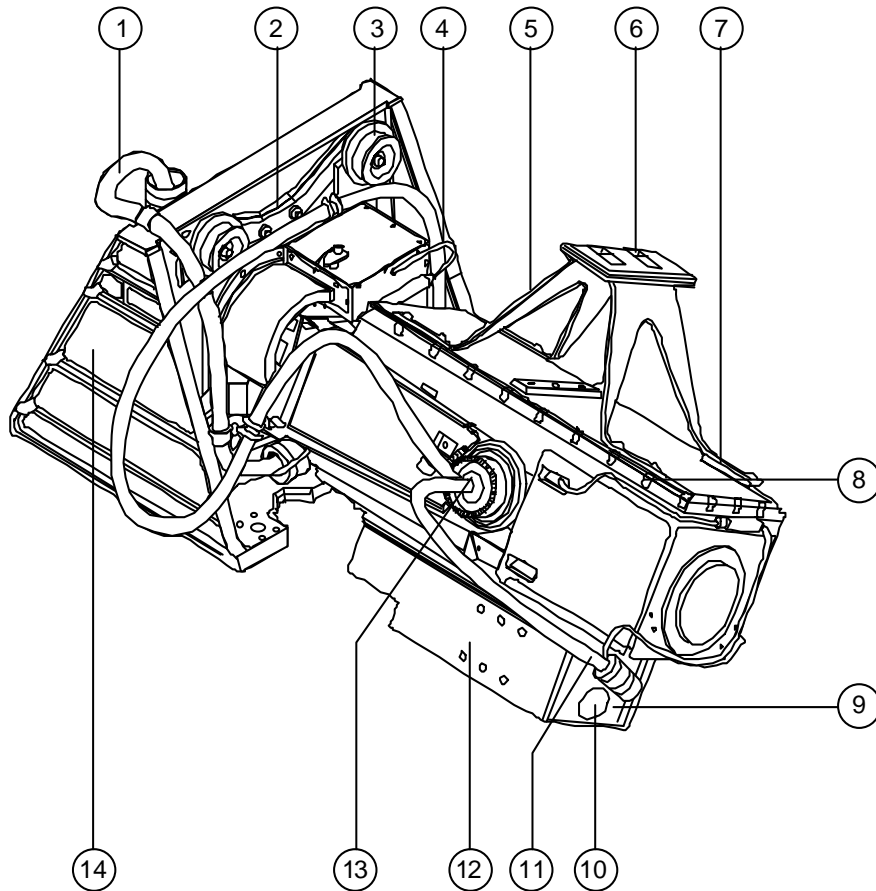

- ① W601 Interface Cable Assembly (EVA releasable at boom I/F)
- ② Isolator Plate
- ③ Isolator (x4)
- ④ PTU External Thermistor Interface Cable\*
- ⑤ Counterweight Support
- ⑥ Counterweight
- ⑦ ITVC
- ⑧ ITCV External Thermistor Interface Cable\*
- ⑨ LDRI Laser Diffuser
- ⑩ LDRI Camera Orifice
- ⑪ LDRI Power/Sync Input and Video Output
- ⑫ LDRI
- ⑬ ITVC Power/Sync Input and Video Output
- ⑭ Boom Interface Bracket (EVA Releasable)

\* Items 4 and 8 are subsets of item 1, the W601 Interface Cable Assembly

jsc48037\_117r2.cvx

# LASER DYNAMIC RANGE IMAGER (LDRI) (Continued)

## NOMENCLATURE (Concluded)

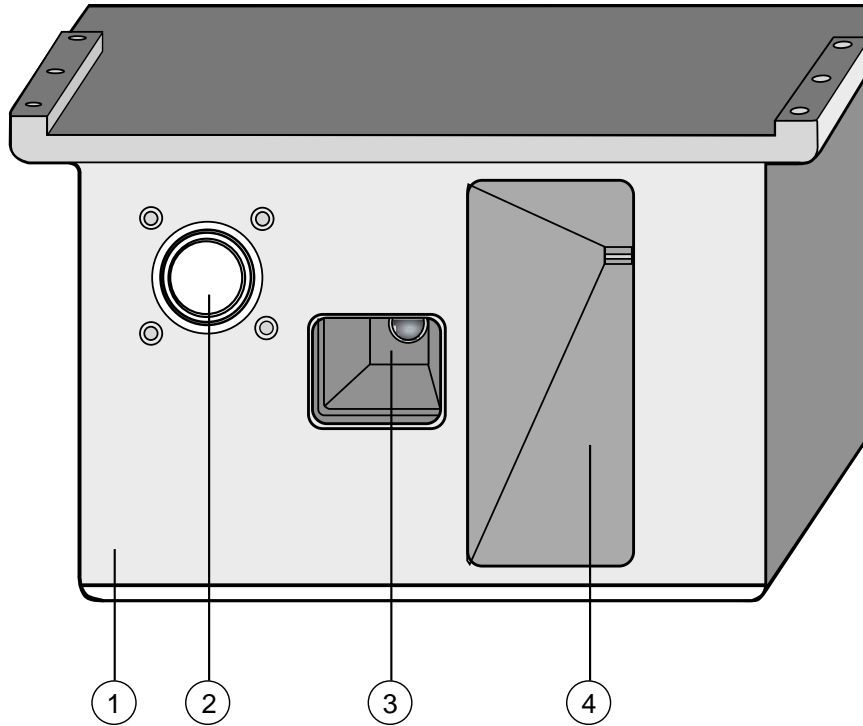

- ① LDRI Front Face
- ② Power/Sync Input and Video Output
- ③ Camera Orifice
- ④ Laser Orifice (covered by diffuser)

jsc48037\_118r3.cvx

# LASER DYNAMIC RANGE IMAGER (LDRI) (Continued)

## OBSS PTU PAN AND TILT RANGES

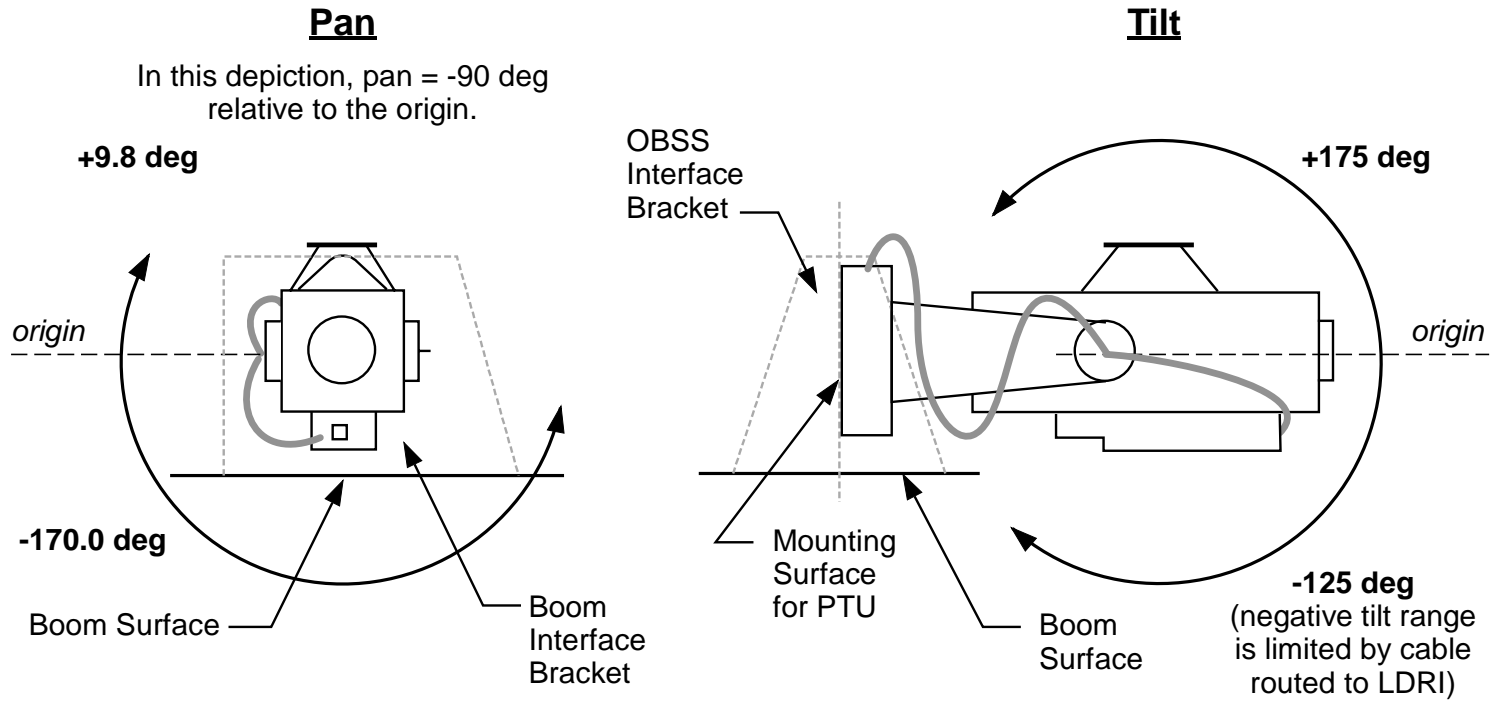

jsc48037\_119r2.cvx

# LASER DYNAMIC RANGE IMAGER (LDRI) (Continued)

## FUNCTIONAL FLOW

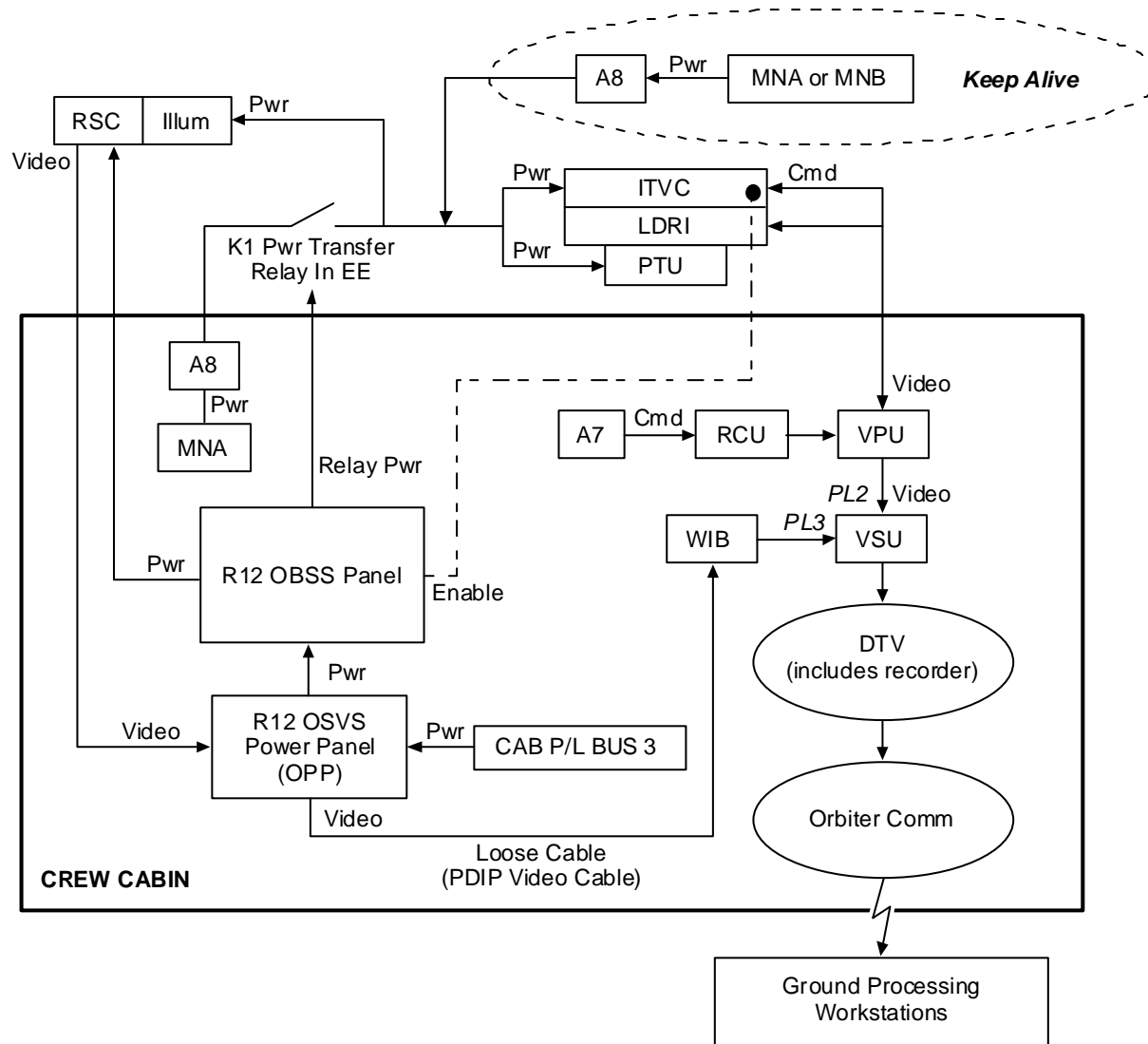

jsc48037\_120r2.cwx



# LASER DYNAMIC RANGE IMAGER (LDRI) (Continued)

## ITVC, LDRI, AND PTU INTERACTIONS

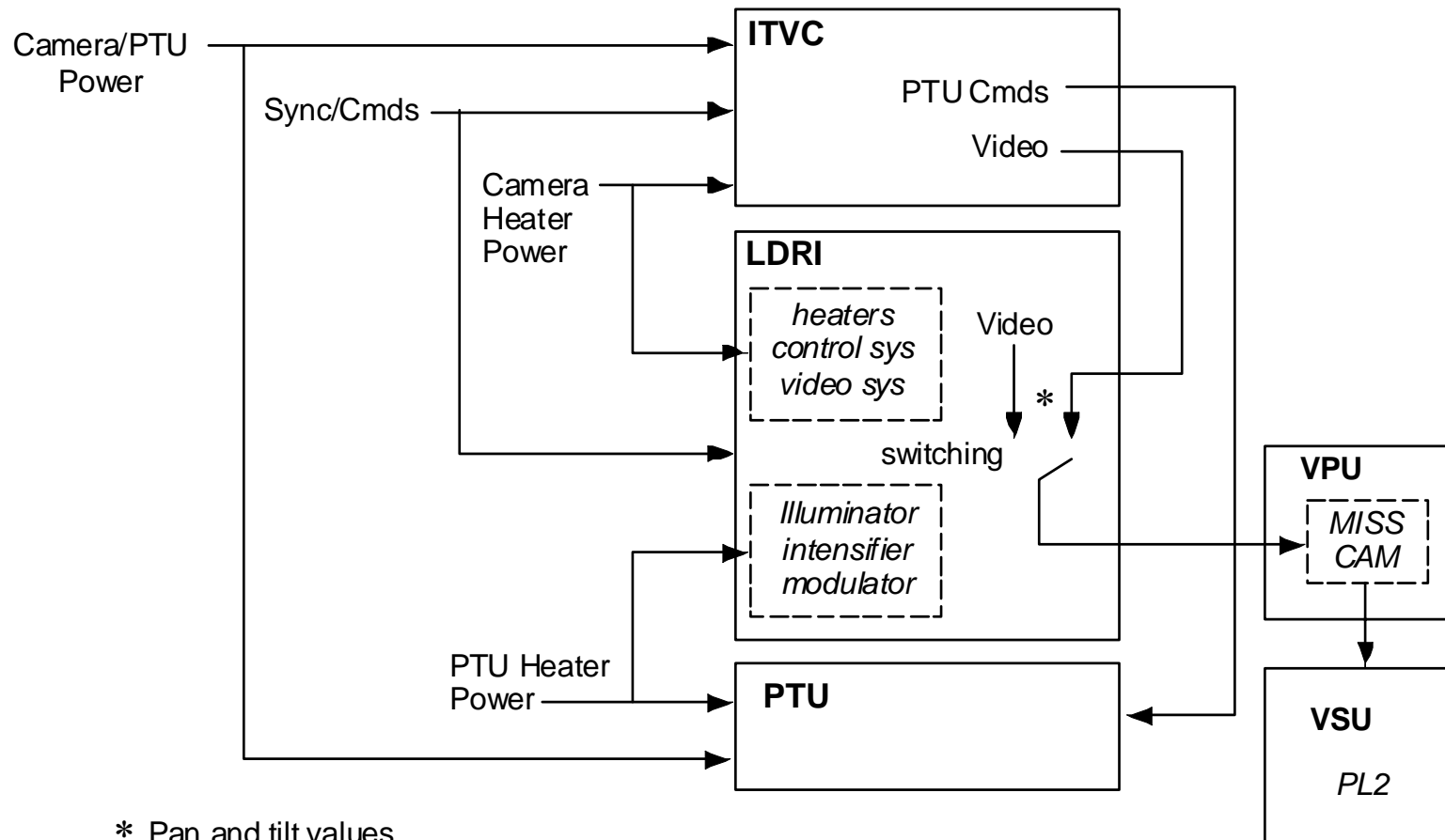

\* Pan and tilt values  
for display on MON

jsc48037\_121r2.cvx

## LASER DYNAMIC RANGE IMAGER (LDRI) (Continued)

### OPP PANEL

#### R12

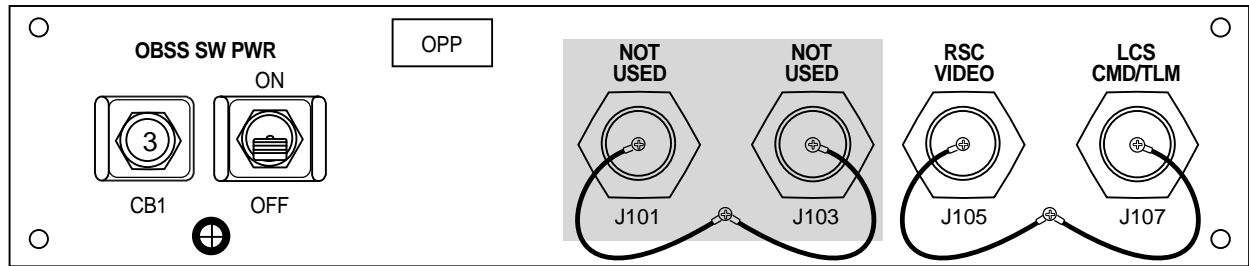

#### **OBSS SW PWR (CB1 AND S1)**

- Closure of 3-amp OBSS SW PWR cb followed by sw will provide CAB PL3 POWER to R12 OBSS panel

#### **RSC VIDEO (J105)**

- Provides balanced, asynchronous video from RMS Sideview Camr (RSC)
- Video will be routed to VSU PL3 input on R12/VPU/WIB using PDIP Video Cable to support viewing/recording/dnlnk ops

#### **LCS CMD/TLM (J107)**

- Provides PGSC interface for crew control, data, and telemetry for Laser Camr System (LCS) and ISIS Digital Camr (IDC)

## LASER DYNAMIC RANGE IMAGER (LDRI) (Continued)

### OBSS PANEL

R12

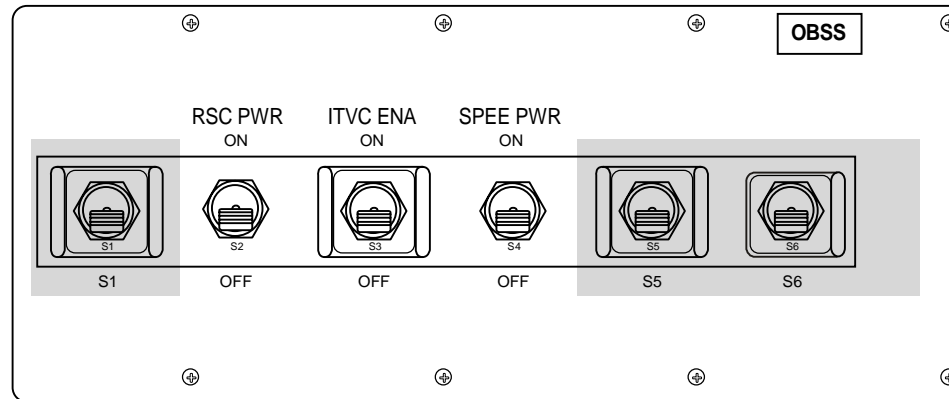

jsc48037\_124r2.cvx

#### **RSC PWR (S2)**

- Provides CABIN PL3 POWER to RMS Sideview Camr (RSC) and its heater
- Heater must remain active for duration of mission

#### **ITVC ENA (S3)**

- ON sends an enable command to the OBSS ITVC
- SPEE PWR must be ON prior to ITVC enable
- OFF disables Camr. A 10-sec wait reqd before re-enabling

#### **SPEE PWR (S4)**

- ON closes K1 pwr relay in RMS End Effector. Pwr flows to OBSS ITVC/LDRI/PTU and to RSC illuminator. Upon initial relay closure, illuminator has pwr but not active
- After initial closure of K1 relay, cycling SPEE PWR sw to OFF, then ON will command RSC illuminator to full pwr (156 LEDs). Subsequent K1 relay cycling will take illuminator to med pwr (84 LEDs), then low pwr (30 LEDs), then OFF, and then back to full pwr
- Cycling K1 relay OFF, then ON will rest OBSS PTU pan and tilt values to zero; take LDRI to stby (Mode 1) and ITVC to manual state

# LASER DYNAMIC RANGE IMAGER (LDRI) (Continued)

## A7 PANEL

A7

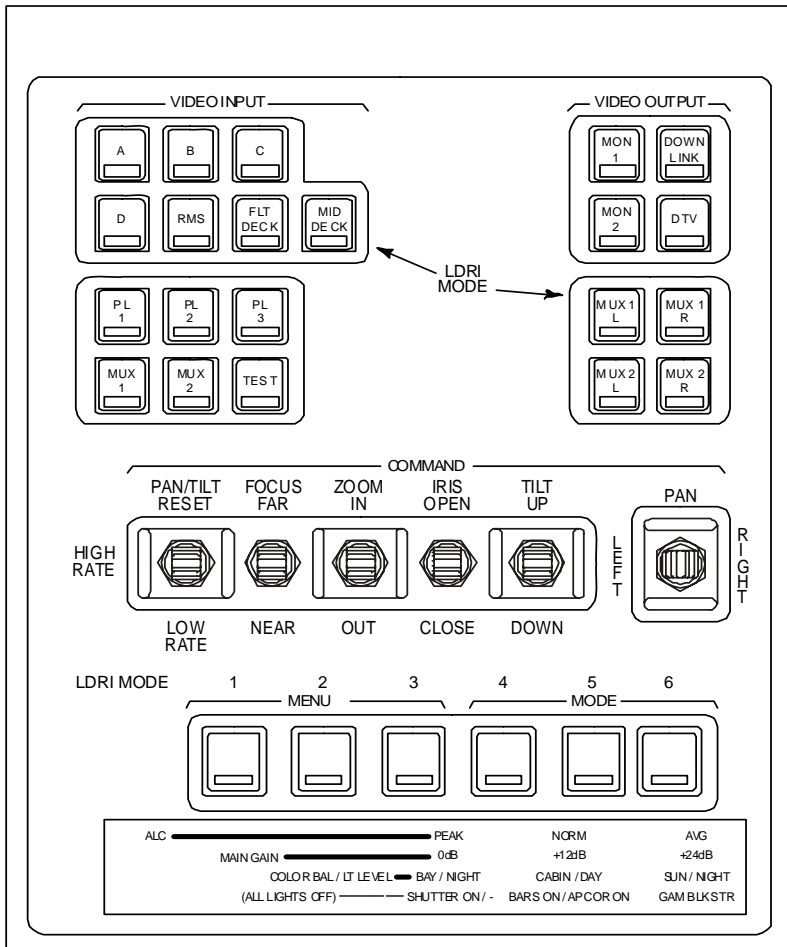

jsc:48037\_125r3.cvx

### NOTE

Command interfaces listed below pertain only to OBSS LDRI and not to OBSS ITVC/PTU. Commands to ITVC/PTU handled by selecting PL2 as video input and treating that address in same manner as PLB ITVC

### MUX1(2)R(L),MIDDECK pb

- Selection of any of four VIDEO OUTPUT MUX pb followed by VID IN MIDDECK pb enables commanding of OBSS LDRI

### IRIS sw

- IRIS sw provides gain cntl for LDRI Modes 3,4,5,6. Feedback is available in MON Lens Data in place of T-stop
- Gain range – 10 (brightest) to 280 (darkest). Default value – 280
- Gain applied on one of Modes 3(4,5,6) will apply to other three. Gain returns to default value by selecting Mode 1

### MODE, MENU pb

- Six MODE/MENU pb, left to right, allow selection of LDRI modes 1 thru 6:
  - MODE 1 – STANDBY
  - MODE 2 – ILLUMINATOR
  - MODE 3 – 2D
  - MODE 4 – 2D GAMMA
  - MODE 5 – 3D
  - MODE 6 – 3D GAMMA
- If OBSS/ITVC cntl selected (by depressing VID OUT pb selected for PL2) while in LDRI modes 3(4,5,6), LDRI video will continue to flow to VID OUT. For this scenario, all ITVC cmds active in blind
- Mode fdbk for Modes 3,4,5,6 avail when PL2 illuminated. In Modes 1 and 2, MODE/MENU pb indicate ITVC exposure setting, not mode

# LASER DYNAMIC RANGE IMAGER (LDRI) (Concluded)

## MONITOR INDICATIONS FOR LDRI VIDEO

### NOTE

LDRI video assigned to PL2 using R12/VPU MISS CAM jumper posn. LDRI video (Modes 3-6) will have black rounded corners. Lens data and green Camr data ON for this illustration

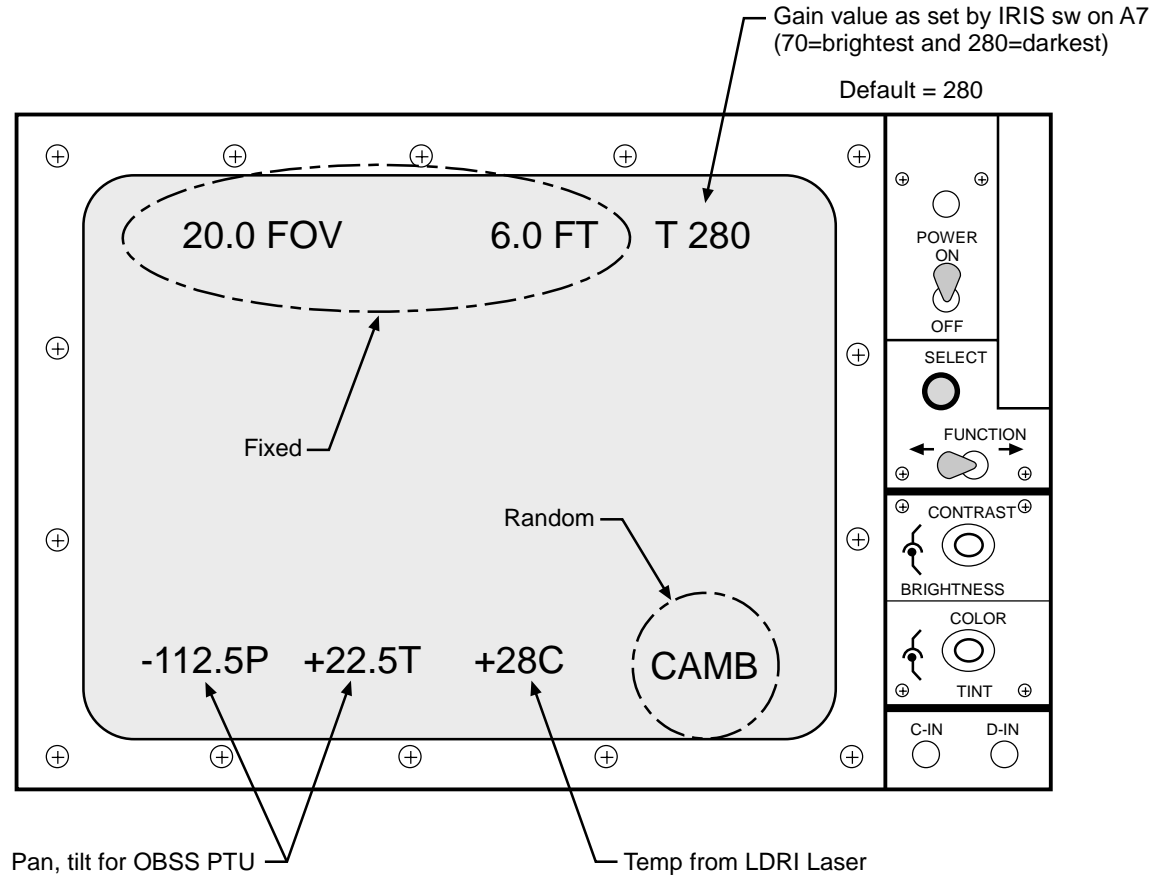

This Page Intentionally Blank

LASER CAMR SYSTEM (LCS)/INTEGRATED SENSOR INSPECTION SYSTEM DIGITAL CAMR (IDC)

I

LCS SPECIFICATIONS.....	20-2
LCS NOMENCLATURE.....	20-3
LCC SOFTWARE GUI.....	20-4
IDC SPECIFICATIONS.....	20-8
IDC NOMENCLATURE .....	20-9
IDC SOFTWARE GUI.....	20-10
LCS/IDC COMBINED NOMENCLATURE .....	20-14
LCS/IDC KEEP ALIVE PWR AND DATA INTERFACES (Berthed on MPMs) .....	20-15
LCC SOFTWARE EXIT DIALOGUE BOXES .....	20-16
MANUAL A31p DESKTOP DNLK SETUP.....	20-17
RECONFIGURATION OF A31p SCREEN RESOLUTION.....	20-20

**LASER CAMR SYSTEM (LCS)/INTEGRATED SENSOR INSPECTION SYSTEM DIGITAL CAMR (IDC)**

**LCS SPECIFICATIONS**

LASER WAVELENGTH:  $\approx$ 1500 nm, near-IR

LASER CLASSIFICATION: Class 3b

OPERATIONAL RANGE: 4-10 ft

LASER SPOT SIZE: 0.04 in @ 4.5 ft

HAZARD ZONE:

Nominal Hazard Keep Out Zone (KOZ) – 5 ft

Worst Case Hazard KOZ – 64 ft

LASER COVERAGE:

Detailed Area and Quick View Scan Modes – 30 x 30 deg

Continuous Line Scan Mode – Variable 2 to 42 deg

LINEAR DETECTION ARRAY (LDA): 256-pixel linear array CCD w/13-bit intensity dynamic range

LCH WEIGHT: 24.5 lb

LCH DIMENSIONS: 11 in (L), 10 in (W), 5.6 in (H)

LCH PWR MODES/SOURCES: Refer to LASER CAMR SYSTEM (LCS)/INTEGRATED SENSOR INSPECTION SYSTEM DIGITAL CAMR (IDC) (PHOTO/TV FS, REF PROC)

HEATER PWR MODES/SOURCES: Refer to LASER CAMR SYSTEM (LCS)/INTEGRATED SENSOR INSPECTION SYSTEM DIGITAL CAMR (IDC) (PHOTO/TV FS, REF PROC)

LASER SCAN MODES:

Detailed Area – Two-directional scanning in rectangular pattern (used for "stop and stare" ops). Both X,Y mirrors used

Quick View – Low-resolution detailed area-scan mode

Continuous Line – One-directional scanning passes thru optical center of FOV (used for scanning ops). RMS provides scanning motion

CREW CONTROL:

Hardware – LCC (Laser Camr Controller – A31p)

Software – LCC software shortcut (Shuttle Apps\IDC)



# LASER CAMR SYSTEM (LCS)/INTEGRATED SENSOR INSPECTION SYSTEM DIGITAL CAMR (IDC) (Continued)

## LCS NOMENCLATURE

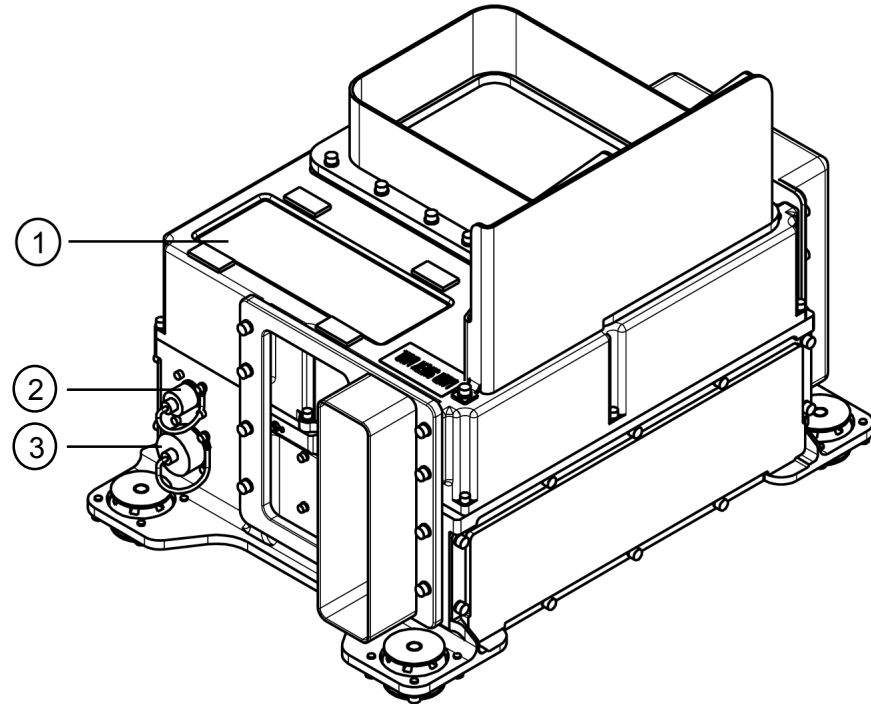
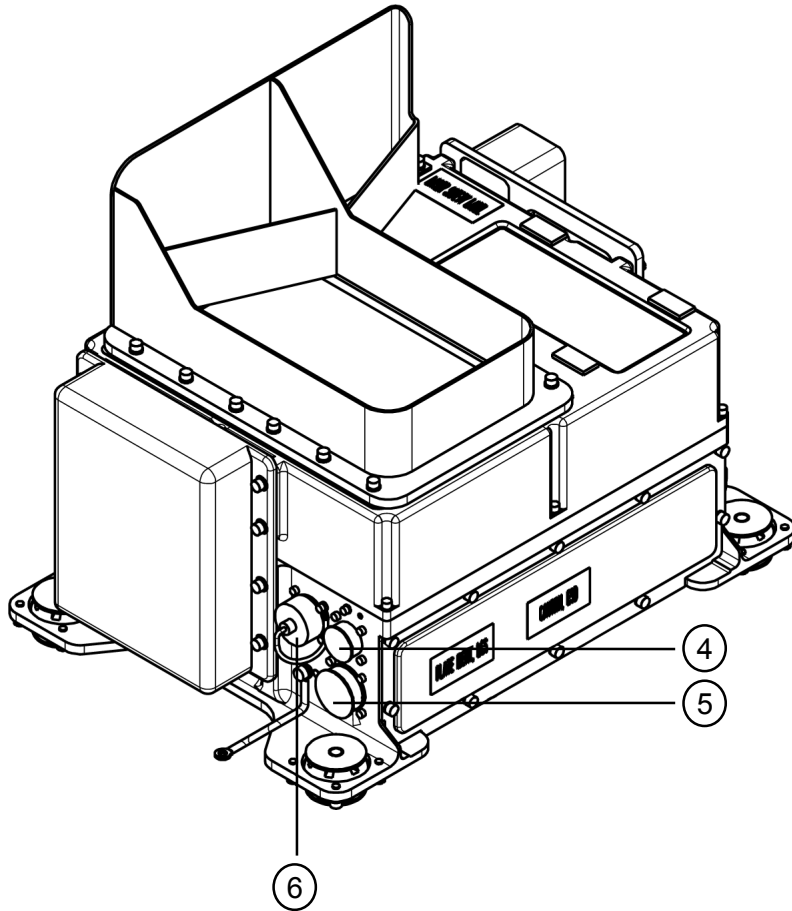

- ① Laser Orifice
- ② RS422 Connector (J4)
- ③ Test Connector (J3)
- ④ COMMS/DATA Connector (J2)
- ⑤ POWER Connector (J1)
- ⑥ Ethernet Peripheral Device Connector (J5)

jsc48037\_177r1.cvx

# LASER CAMR SYSTEM (LCS)/INTEGRATED SENSOR INSPECTION SYSTEM DIGITAL CAMR (IDC) (Continued)

## LCC SOFTWARE GUI

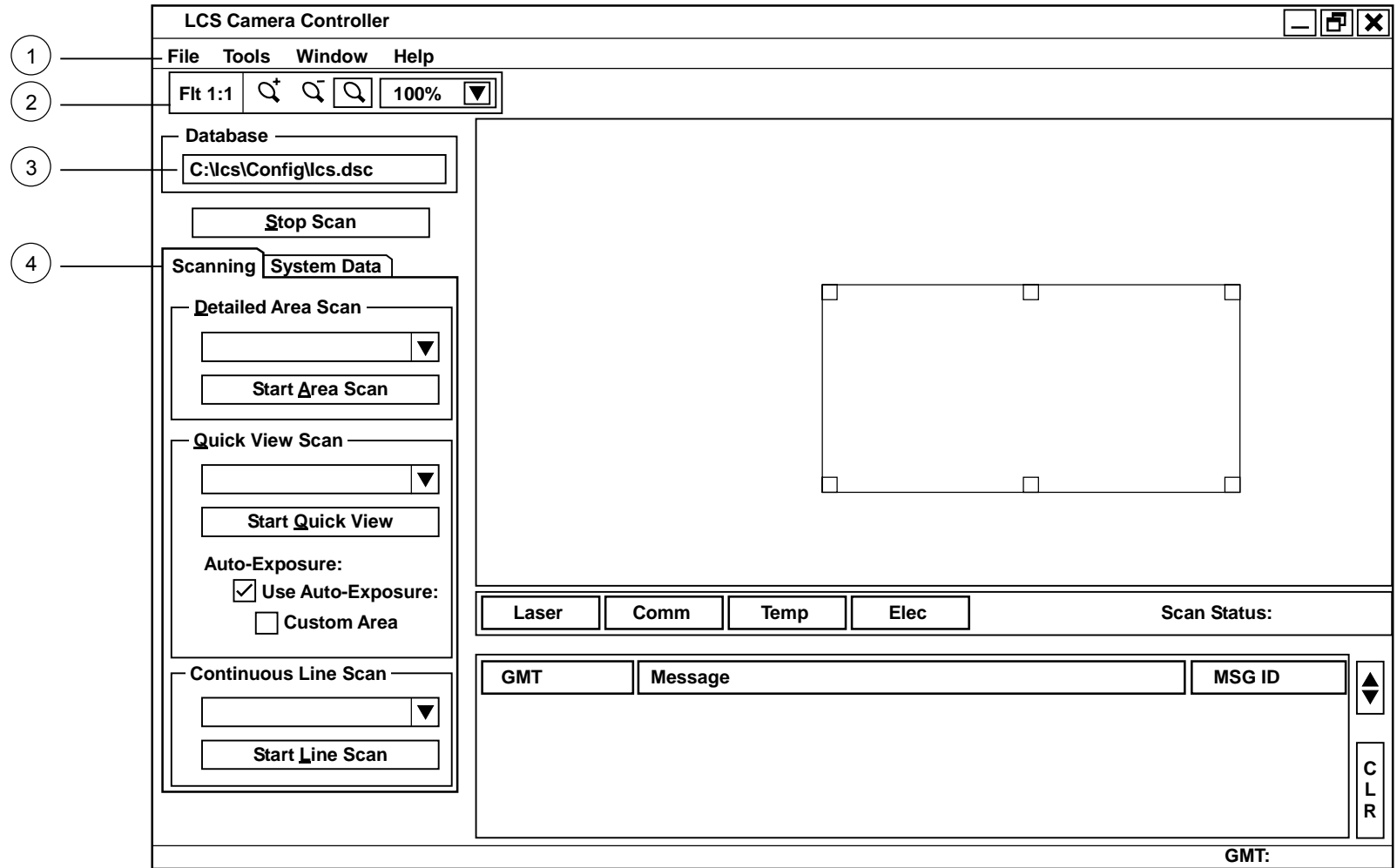

jsc48037\_178r1.cvx

# LASER CAMR SYSTEM (LCS)/INTEGRATED SENSOR INSPECTION SYSTEM DIGITAL CAMR (IDC) (Continued)

## LCC SOFTWARE GUI (Continued)

1	Menu Bar [File, Tools, Help]			
	[File]	Open	Allows user to open and view previous scan bin files. If several open, they are shown in order under File menu	
		Close	Closes displayed scan bin file. Appears only when viewing previous scans. If several open, only currently selected file will be closed with this function	
		Close All	Closes all scan bin files. Appears only when viewing previous scans. If several open, all files will be closed. Multiple scans collected in series will reside in RAM until cleared with this feature. Good housekeeping feature to use between scan AOs	
		Load Database	Allows user to change current database. When load database option selected, a window will appear and allow user to select another database. Only files w/.dsc extension selectable	
		Exit	See LCC SOFTWARE EXIT DIALOGUE BOXES, 21-16	
	[Tools]	Set GMT	Sets GMT clock on both LCC,LCH. When selected, window will appear allowing A31p time to be set. LCC time must be within 3 sec of onboard SM GPC. Once clock set, LCC A31p will update its system clock every 5 min using LCH system clock if LCC GUI running	
		IDC Control	Not used. Allows user to pwr on(off) IDC. This task preferably done via IDC software	
		Zoom Toolbar	Allows Zoom Toolbar to be displayed under Menu Bar	
		Intensity Adjustments	Not currently selected(used). Invokes Intensity Adjustment window on GUI so user can adjust Gamma, Brightness, and Contrast of displayed scan image	
		Peak Status Highlight	Not currently selected(used). Invokes Peak Status window so user to select voxel status: Below Min Intensity, Above Max Intensity, Overflow, Underflow, Invalid Peak, No Peak, and Multiple Highlights	
	[Window] (Menu appears only when scan bin files being viewed)	Status Toobar	Allows Status Toolbar to be displayed below GUI. Contains only GMT	
		Cascade	Cascades all currently opened scan bin files	
		Tile Vertically	Will 'vertically tile' all opened scan bin files. User can scroll up,down with vertical,horizontal slide bars	
		Tile Horizontally	Will 'horizontally tile' all opened scan bin files. User can scroll up with vertical slide bar	
[Help]	Arrange Icons	If multiple windows open and minimized in display area, will align minimized files		
	About	Displays window w/software-specific information; i.e., version of release		
2	Zoom Toolbar			
	Fit 1:1	If displayed scan bin file has been zoomed in(out), button allows user to fit image to display area		
	Magnifier w/+ Sign	Zoom in button		
	Magnifier w/- Sign	Zoom out button		
	Magnifier in box	Allows user to select a box on display to zoom in on. Mouse arrow will change to magnifier. User will outline area w/two mouse clicks and view is fitted in display area		
Zoom Percentage Menu	Allows user to zoom in(out) according percentage displayed. Selectable percentages: 25%, 50%, 75%, 100%, 150%, 200%, 300%, 400%, Fit to Window			
3	Database	Displays current database and its path. Default is "c:\lcs\config\lcs.doc"		
	File	Displays name of current file being saved on LCC hard drive during scan. Will display last scan file name when no scan in progress		
4	Scanning Page [Detailed Area Scan, Continuous Line Scan, Quick View Scan] (One of two pages which allows user to select scan from one of three drop-down menus and execute each type of scan)			
	[Detailed Area Scan]	Detailed Area Scan	Drop-down menu allows user to select one out of a possible 30 detailed area scans	
		Start Area Scan	Executes detailed area scan selected from drop-down menu	
	[Quick View Scan]	Detailed Area Scan	Drop-down menu allows user to select one out of a possible 10 quick-view scans	
		Start Quick View	Executes quick-view scan selected from drop-down menu	
	[Auto-Exposure]	Use Auto-Exposure	Enables Auto-Exposure. AE feature adds ~10 sec. Three initial scans taken and exposure calculated based on those scans	
		Custom Area	Enables Custom Area Box in image as reqd. Auto-exposure calculated from Custom Area Box	
	[Continuous Line Scan]	Detailed Area Scan	Drop-down menu allows user to select one out of a possible 30 continuous line scans	
Start Line Scan		Executes continuous line scan selected from drop-down menu		

# LASER CAMR SYSTEM (LCS)/INTEGRATED SENSOR INSPECTION SYSTEM DIGITAL CAMR (IDC) (Continued)

## LCC SOFTWARE GUI (Continued)

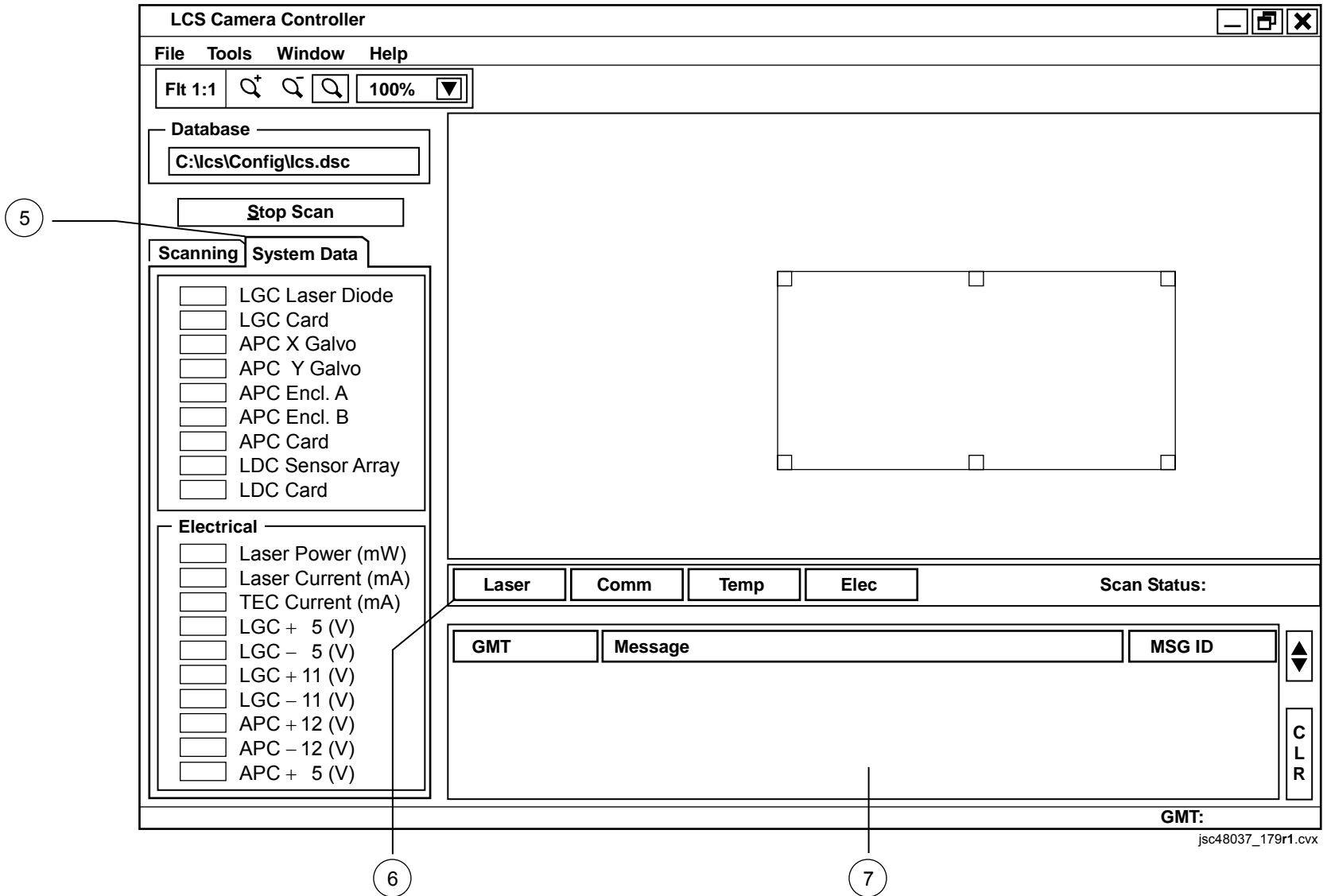

# LASER CAMR SYSTEM (LCS)/INTEGRATED SENSOR INSPECTION SYSTEM DIGITAL CAMR (IDC) (Continued)

## LCC SOFTWARE GUI (Concluded)

5	System Data Page [Temperature (degC), Electrical] (One of two pages. Gives user insight into various temp,elec values of components inside LCH. Values are software FDA'd according to limits set in current database. An out of allowable limit value is backlit in yellow and causes a msg to be displayed)	
	[Temperature]	Displays LCH component temp values in deg Celsius
	[Electrical]	Displays LCH component elec values. Values are milliWatts, milliamps, and Volts
6	Laser On/Off [Laser On, Laser Off, Laser ?] (Displays on,off status of Laser diode)	
	Laser On (Green)	Scan in progress. Backlit in green while laser diode on
	Laser Off (Blue)	Scan not in progress. Backlit in blue while laser diode off
	Laser ? (Gray)	No insight into LCH. Backlit in gray when no LCH to LCC Ethernet connectivity
	Comm	Light displays Ethernet communication state between LCC,LCH Green Light – Indicates good Ethernet connection Yellow Light – Indicates bad Ethernet connection
	Temp	
	Temp (Green/Yellow)	Light displays temp status of LCH components Green Light – Backlit in green when all LCH component temp values within ranges specified by current database Yellow Light – Backlit in yellow when one or more values out of limits
	Elec	
	Elec (Green/Yellow)	Light displays elec status of LCH components Green Light – Backlit in green when all elec values within ranges specified by current database Yellow Light – Backlit in yellow when one or more values out of limits
	Scan Status (Blank, Complete, Vertical Resolution)	
Blank	When LCS software launched and no scans have been executed	
Complete	Displays last scan line collected or Stop Scan button selected	
Vertical Resolution	While scan in progress, field displays vertical resolution of scan and current line being scanned; i.e., 211/512 means current line being scanned and recorded on LCC is 211 and vertical resolution is 512	
7	Message Area	
	GMT	Displays GMT of time tagged off-nominal message
	Message	Displays text description of error messages. Any messages displayed here are logged into system log
	MSG ID	Display unique six-digit number that corresponds to error message that appears in message area
	CLR	Clears current error messages displayed in message area. Button will invoke a dialogue box asking user if he wants to clear message area
	GMT DDD/HH:MM:SS	Displays GMT based on A31p system clock. Once GMT set via Tools menu, LCC will sync up to time kept on LCH, which is accurate

## LASER CAMR SYSTEM (LCS)/INTEGRATED SENSOR INSPECTION SYSTEM DIGITAL CAMR (IDC) (Continued)

### IDC SPECIFICATIONS

IDC DIMENSIONS: 6 in (L), 5 in (W), 2 in (D)

IDC ELECTRONIC COMPONENTS: Adimec-2000m/S and Pleora i-port PT1000-CL

IDC ELECTRONIC PWR: 12V conditioned pwr from LCH

HEATER PWR MODES/SOURCES: Refer to LASER CAMR SYSTEM (LCS)/INTEGRATED SENSOR INSPECTION SYSTEM DIGITAL CAMR (IDC) (PHOTO/TV FS, REF PROC)

IMAGER MODEL: Adimec-2000m/S gray-scale imager

CCD: 1920 x 1080

CCD PIXEL SIZE: 7.4 microns (square pixels)

SPECTRAL RESPONSE:

350 nanometers (25%)

500 nanometers (42% Peak)

700 nanometers (20%)

FOCAL LENGTH: 50mm

DYNAMIC RANGE: 60dB

GAIN: 1X-8X

APERTURE: f/8

FOCUS DISTANCE: 6 ft 3 in

WORKING DISTANCE: 5 ft

Target Resolution at 5 ft: 113 pixels/in

Horizontal Coverage at 5 ft: 17 in

Vertical Coverage at 5 ft: 10 in

INTERFACE: 10Base2 half duplex

CREW CONTROL:

Hardware – LCC (Laser Camr Controller – A31p)

Software – LCC software shortcut (Shuttle Apps\IDC)

IMAGE FORMAT: 16-bit tif

# LASER CAMR SYSTEM (LCS)/INTEGRATED SENSOR INSPECTION SYSTEM DIGITAL CAMR (IDC) (Continued)

## IDC NOMENCLATURE

- ① DCA to LCH Cable Connector
- ② Digital Camr Assy (DCA)
- ③ Lens Attachment

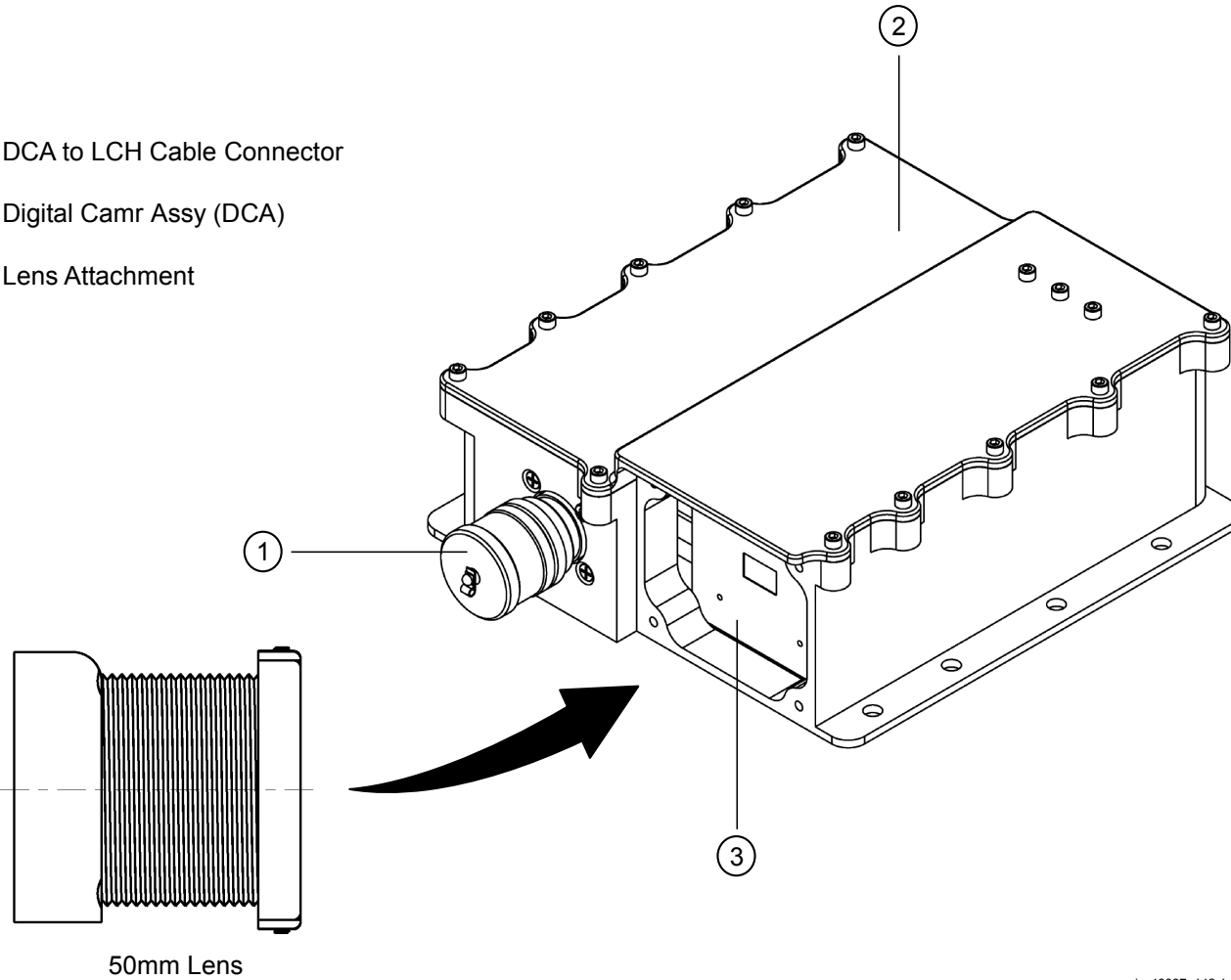

jsc48037\_142r1.cvx

# LASER CAMR SYSTEM (LCS)/INTEGRATED SENSOR INSPECTION SYSTEM DIGITAL CAMR (IDC) (Continued)

## IDC SOFTWARE GUI

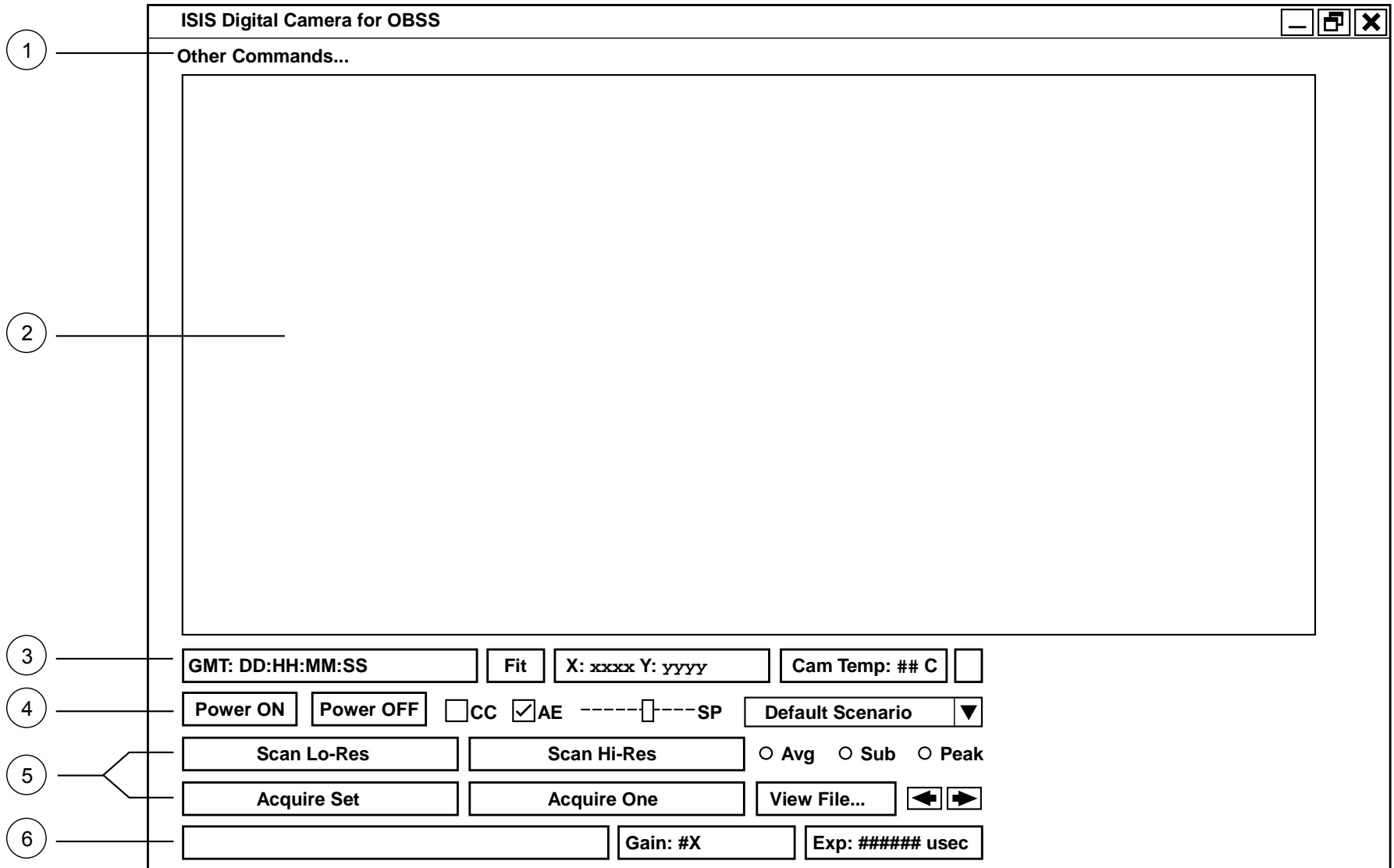

jsc48037\_180r1.cvx



# LASER CAMR SYSTEM (LCS)/INTEGRATED SENSOR INSPECTION SYSTEM DIGITAL CAMR (IDC) (Continued)

## IDC SOFTWARE GUI (Continued)

1	Other Commands (Pulldown menu provides other commands w/hot keys)		
	Advanced Command	Brings up an Advanced Settings dialog box in which user may apply or see specific setting for individual image acquisition options. See pg 21-12	
	[F2]	Brings up "Add Notation" box for adding text to tiff. This text will be added to all tiffs; so, clear it if added to text box	
	[F5]	Toggle Summary View	
	[F6]	Toggle Image Mode	
	[F7]	Zoom In	
	[F8]	Zoom Out	
	[F9]	Reset Brightness and Contrast	
	[F10]	Reset Auto Exposure Aperture to Default	
	[F11]	Toggle Auto Exposure Aperture Visibility	
	[F12]	Find Auto Exposure Aperture	
2	Display Area	Shows the tiff or last image collected	
3	Status Bar 1		
	GMT	Displays current time	
	Zoom Level	Fit, 1X, 2X, 4X, 8X	
	Mouse Position	Shows "X,Y" positions of mouse	
	Camr Temperature	Temperature of Camr in Celsius	
	Comm Status Light	Blinking green light when in nominal case; static while imaging	
4	Power On/Off, Auto Exposure (AE), Color Coded (CC), Scenario File Drop List/Brightness and Contrast Controls]		
	[Power On]/[Power Off]	Buttons control the pwr to the IDC	
	[CC]	Allows user to color code the over and under exposed areas of image	
	[AE]	Allows selection of auto-exposure capability	
	AE Setpoint Slide Bar	Allows user to set starting exposure for AE algorithm. Bar can be used when Avg, Sub, and Peak algorithms selected	
	Scenario File Drop List	Drop down list allows user to select Gain and Exposure settings for all image acquisition buttons that depend upon light scenario	
	Brightness and Contrast	When user switches into "Image Mode", scenario drop down list turns into "Brightness and Contrast" controls, allowing user to manipulate viewable image Note: Brightness and Contrast has no control over Camr brightness or contrast	
5	Image Command Area		
	Image Acquisition Buttons (Each button may be accessed during another operation to switch acquisition types quickly. Allows user to set scene with "Scan Lo-Res" and then immediately select "Scan Hi-Res", "Acquire Set" or "Acquire One" as needed without extra action		
		Scan Lo-Res	Image(s) not saved to disk. Displays decimated Camr view. Used to set software exposure and situational awareness
		Scan Hi-Res	Continuously saves full images to disk
		Acquire Set	Image(s) saved to disk. Acquires bracket set of images
		Acquire One	Image saved to disk. Acquires one image with no exposure control from AE
		Avg	Selects averaging AE algorithm. Exposes based on pixels inside box
		Sub	Selects sub image AE algorithm. Takes two images
	Peak	Selects peak AE algorithm. Exposes based on brightest pixels in box	
	View and Save Files	Allows user to select a file from a directory to view or (when holding "CTRL" key while clicking on "Save File To..." button) select a directory indicating where subsequent images will be saved. Green arrows allow user to quickly browse thru images alphabetically	
6	Status Bar 2	Contains status of current operation, gain and exposure settings for image being displayed, Status Bar Error Advisory, Status Error Strings, and Normal Operation Strings	

# LASER CAMR SYSTEM (LCS)/INTEGRATED SENSOR INSPECTION SYSTEM DIGITAL CAMR (IDC) (Continued)

## IDC SOFTWARE GUI (Continued)

The image shows a software dialog box titled "Advanced Settings" with a close button (X) in the top right corner. The dialog is divided into three main sections: "Acquire One", "Acquire Set", and "Scan".

- Acquire One:** Contains "Exposure" (input field with "#####" and "usec") and "Gain" (input field with "#X" and a dropdown arrow).
- Acquire Set:** Contains "Select Image:" (input field with "#" and a spinner), "Exposure" (input field with "#####" and "usec"), "Gain" (input field with "#X" and a dropdown arrow), and "or Fraction" (input field with "X").
- Scan:** Contains "Select Type:" with radio buttons for "Lo-Res" (selected) and "Hi-Res", "Exposure" (input field with "#####" and "usec"), "Gain" (input field with "#X" and a dropdown arrow), "Decimation" (input field with "##" and a spinner), and "Period" (input field with "X" and "msec").

At the bottom of the dialog, there are three buttons: "Do Self Test", "Black Level" (input field with "##"), and a group of three buttons: "Cancel", "Reset to Defaults", and "Accept".

Callouts 8, 9, 10, and 11 are shown as circles with lines pointing to the "Exposure" field in "Acquire One", the "Select Image:" field in "Acquire Set", the "Lo-Res" radio button in "Scan", and the "Do Self Test" button, respectively.

jsc48037\_s20\_181r3.cvx

## LASER CAMR SYSTEM (LCS)/INTEGRATED SENSOR INSPECTION SYSTEM DIGITAL CAMR (IDC) (Continued)

### IDC SOFTWARE GUI (Concluded)

8	"Acquire One" Settings (Allows user to set exposure and gain settings for "Acquire One" cmd which acquires a single image from Camr)	
	[Exposure]	User may set exposure from 25 usec to 80025 usec
	[Gain]	User may set Gain from 1X to 8X
9	"Acquire Set" Settings (user to set exposure and gain settings for "Acquire Set" cmd. Each image acquired in set can have a different setting for exposure and gain. [Display] checkbox will determine if image is to be displayed when acquired)	
	[Select Image]	As a default, user may select up to 7 images
	[Exposure]	User may set exposure from 25 usec to 80025 usec
	[Gain]	User may set Gain from 1X to 8X
	[or Fraction]	Shows denominator value for exposure value. A "1" is assumed for the numerator
10	"Scan" Settings (Allows user to exposure, gain, and decimation settings for low/high resolution continuous scans)	
	[Lo-Res]/[Hi-Res] Buttons	User selects which scan to set attributes to: Lo-Res – Scans are displayed only and not saved to disk Hi-Res – Scans are displayed and saved to disk
	[Exposure]	User may set exposure from 25 usec to 80025 usec
	[Gain]	User may set Gain from 1X to 8X
	[Decimation]	User may select a decimation level between 1-16. When decimation is a high number, time for image to be displayed on screen is faster due to smaller size and lower quality of image
	[Period]	Sets scan period. Allows user to throttle rate of image/file creation for some scan scenarios
11	"Do Self Test" Command	Queries IDC for an image test pattern which is then displayed on main display window. Test image is also stored to disk
	"Black Level" Input Box	Sets Camr's "Black Level" threshold for all acquired images. Can be set from 0 to 4095
	"Reset to Defaults" Command	Restores application defaults applied at startup to all settings. Holding CTRL and pressing "Reset to Defaults" will restore project defaults established in DCCS.ini file

# LASER CAMR SYSTEM (LCS)/INTEGRATED SENSOR INSPECTION SYSTEM DIGITAL CAMR (IDC) (Continued)

## LCS/IDC COMBINED NOMENCLATURE

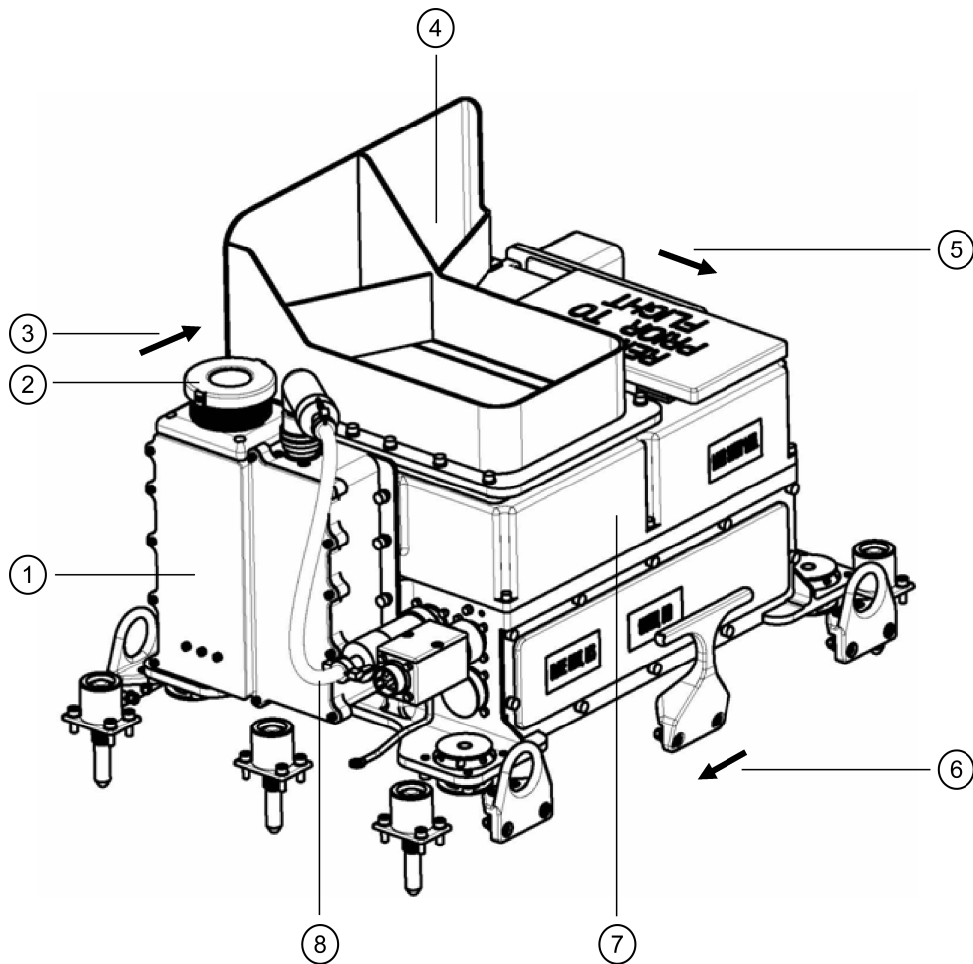

- ① ISIS Digital Camr (IDC)
- ② 50mm Lens
- ③ Top View (from IDC perspective)
- ④ LCH Radiator
- ⑤ Top View (from LCH scan perspective)
- ⑥ Towards OBSS Grapple Fixtures
- ⑦ Laser Camr Head (LCH)
- ⑧ Laser Camr Head (LCH) to Digital Camr Assy (DCA) Cable

jsc48037\_143r1.cvx

# LASER CAMR SYSTEM (LCS)/INTEGRATED SENSOR INSPECTION SYSTEM DIGITAL CAMR (IDC) (Continued)

## LCS/IDC KEEP ALIVE PWR AND DATA INTERFACES (Berthed on MPMs)

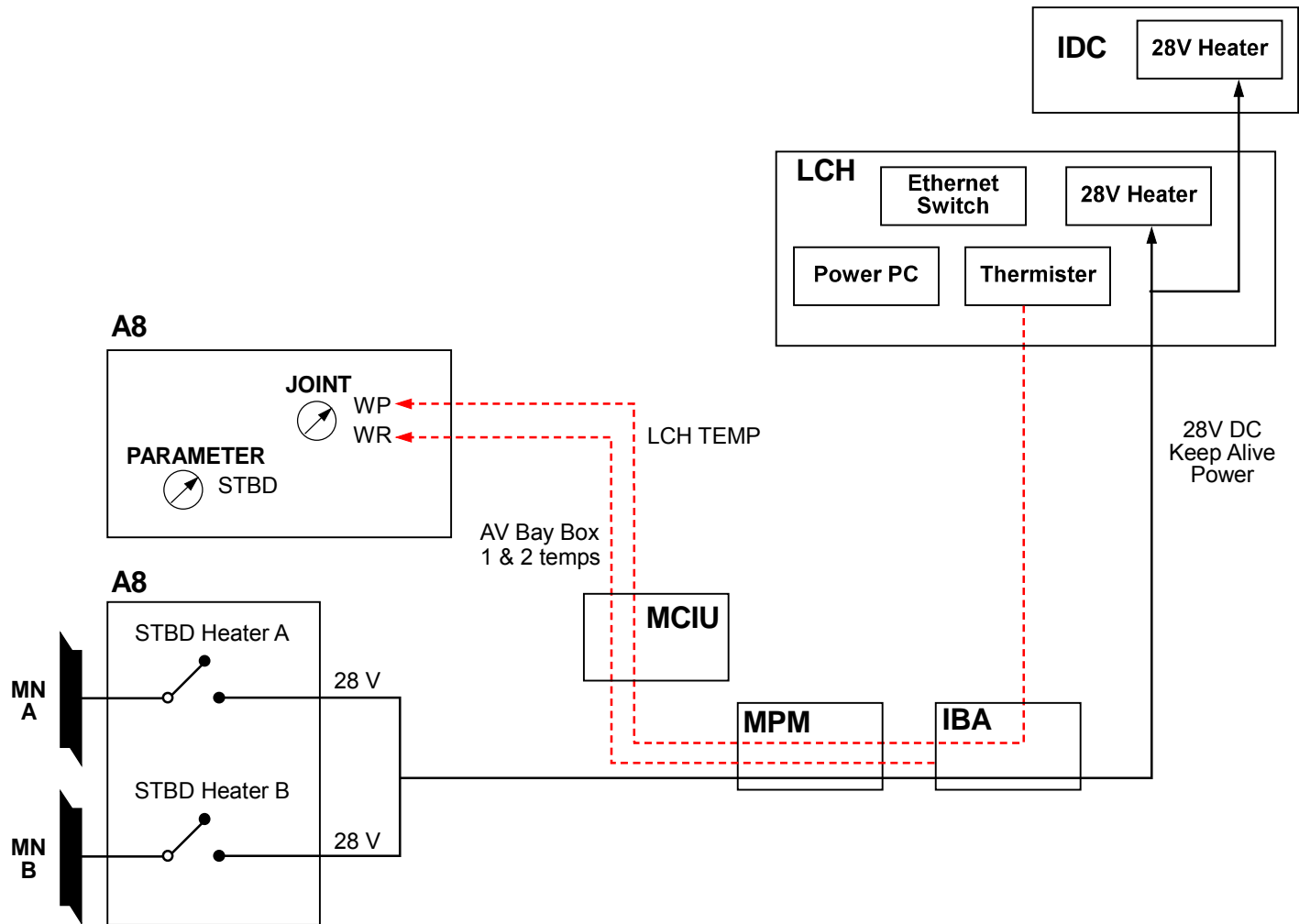

jsc48037\_138r3.cvx

# LASER CAMR SYSTEM (LCS)/INTEGRATED SENSOR INSPECTION SYSTEM DIGITAL CAMR (IDC) (Continued)

## LCC SOFTWARE EXIT DIALOGUE BOXES

Case 1: Selecting "File" and choosing "Exit" w/green Comm light.

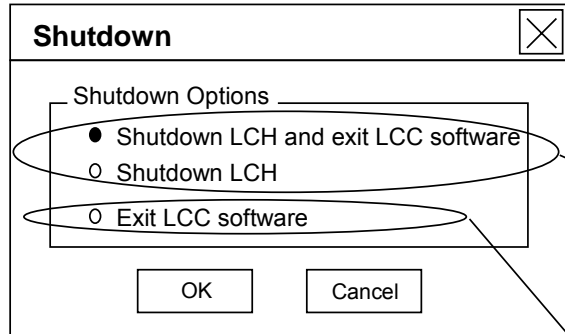

When either "Shutdown LCH and exit LCC software" or "Shutdown LCH" are selected from "Shutdown" dialogue box, following "Shutdown?" dialogue box displayed:

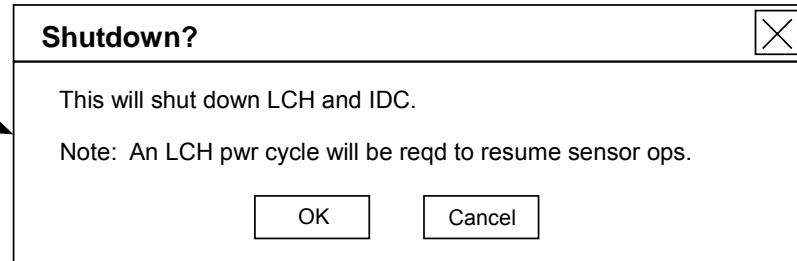

When "Exit LCC software" is selected from "Shutdown" dialogue box, following "Shutdown?" dialogue box displayed:

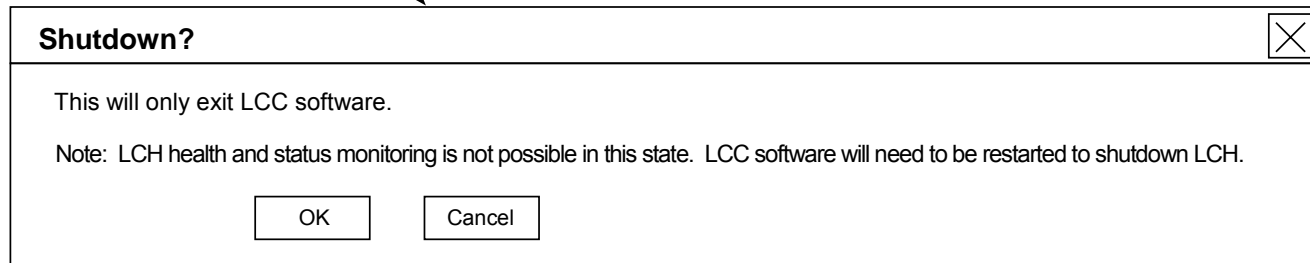

Case 2: Selecting "File" and choosing "Exit" w/yellow Comm light.

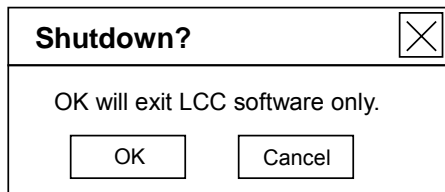

jsc48037\_160.cvx

## LASER CAMR SYSTEM (LCS)/INTEGRATED SENSOR INSPECTION SYSTEM DIGITAL CAMR (IDC) (Continued)

### MANUAL A31p DESKTOP DNLK SETUP

#### NOTE

For desktop dnlk config to work correctly, ensure there is a load on A31p Video Out port (video coming out of laptop into pwr input, such as AVIU(V10))

- |               |   |
|---------------|---|
| MO58F<br>AVIU | 1. <input checked="" type="checkbox"/> Video destination properly configured per LCC ACTIVATION, step 1 (Cue Card, <u>LCS</u> ) and pwrd<br><input checked="" type="checkbox"/> TV PWR – ON<br><input checked="" type="checkbox"/> HI-Z/75 – 75   |
| CC            | <input checked="" type="checkbox"/> PWR SELECT – LO<br>PWR – OFF  |
| A31p          | 2. <u>Desktop</u><br>Right click<br>Sel 'Properties'  |
|               | 3. <u>'Display Properties' Dialog Box</u><br>Sel 'Settings'<br><input checked="" type="checkbox"/> Screen Area – 1024 x 768<br>If not 1024 x 768:<br>Move Screen Area slidebar to 1024 x 768<br>Sel 'Apply'<br>When second 'Display Properties' dialog box opens:<br>Sel 'OK'<br>When 'Monitor Settings' dialog box opens:<br>Sel 'Yes' |
|               | 4. <u>'Display Properties' Dialog Box</u><br>Sel 'Advanced'   |
|               | 5. <u>'(Multiple Monitors) and ATI MOBILITY FIRE GL 7800 Properties' Dialog Box</u><br>Sel 'Displays' tab   |

# LASER CAMR SYSTEM (LCS)/INTEGRATED SENSOR INSPECTION SYSTEM DIGITAL CAMR (IDC) (Continued)

## MANUAL A31p DESKTOP DNLK SETUP (Continued)

6. ✓ 'Displays' tab against fig 20-1 cases' circled areas and perform matching case steps below:

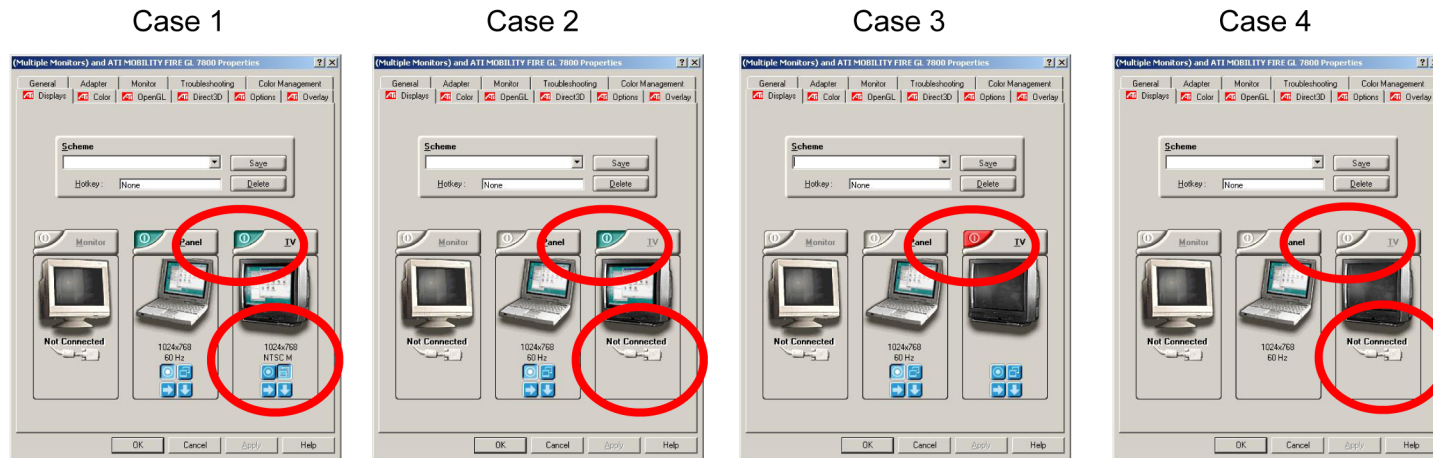

Figure 20-1.- Multiple monitors and ATI mobility fire GL 7800 display tab.

If Case 1 (Video out port enabled and good A31p video to powered AVIU):

Sel 'OK'

If Case 2 (Video signal lost due to bad LCS video cable, adapter, or AVIU setting):

Sel 'OK'

✓TV PWR – ON

✓LCS Video Cable connected to J1

✓LCS Video Adapter connected to A31p Video Out port

Repeat steps 4-6

If Case 3 (Video out port disabled and good LCS video cable connection to powered AVIU):

Click on red button in Case 3 circle

✓Display looks like Case 1

Sel 'OK'

When ATI Property Page appears:

Sel 'Yes'

MO58F  
AVIU  
A31p



## LASER CAMR SYSTEM (LCS)/INTEGRATED SENSOR INSPECTION SYSTEM DIGITAL CAMR (IDC) (Continued)

### MANUAL A31p DESKTOP DNLK SETUP (Concluded)

66. (Concluded)

~

|  
If Case 4 (Bad LCS video cable, adapter, or connection, AVIU not powered or configured or A31p port problem):

AVIU  
A31p

Sel 'OK'

√LCS Video Cable connected to J1

√LCS Video Adapter connected to A31p Video Out port

Repeat steps 4-6

If no longer Case 4:

| Repeat step 6

If still Case 4:

Sel 'OK'

Replace entire LCS Video Cable (including A31p Video Adapter)

Repeat steps 4-6

If no longer Case 4:

| Repeat step 6

If still Case 4:

Sel 'OK'

Replace AVIU

Repeat steps 4-6

If no longer Case 4:

| Repeat step 6

If still Case 4:

Sel 'OK'

Replace A31p

Repeat steps 1-6

If no longer Case 4:

| Repeat step 6

If still Case 4:

√MCC

7. 'Display Properties' Dialog Box

Sel 'OK'

## LASER CAMR SYSTEM (LCS)/INTEGRATED SENSOR INSPECTION SYSTEM DIGITAL CAMR (IDC) (Continued)

### RECONFIGURATION OF A31p SCREEN RESOLUTION

#### NOTE

Following steps will disable auto reconfiguration that automatically ships video. Capture Card will need to be manually configured using MANUAL A31p USING DESKTOP DNLK SETUP procedure, 20-17 for desktop dnlk ops

- A31p
1. Desktop  
Right click  
Sel 'Properties'
  2. 'Display Properties' Dialog Box  
Sel 'Settings'  
Sel 'Advanced'
  3. '(Multiple Monitors) and ATI MOBILITY FIRE GL 7800 Properties' Dialog Box  
Sel 'Displays'
  4. TV display tab  
If Red(Gray) tab:  
| Go to step 5  
If Green tab:  
Click Green tab. Tab automatically turns red after selection (see fig 20-1)  
Sel 'Apply'
  5. 'ATI Property Page' Dialog Box  
Sel 'Yes'
  6. '(Multiple Monitors) and ATI MOBILITY FIRE GL 7800 Properties' Dialog Box  
Sel 'OK'
  7. 'Display Properties' Dialog Box  
Sel 'OK'
  8. Desktop  
Right Click  
Sel 'Properties'

## LASER CAMR SYSTEM (LCS)/INTEGRATED SENSOR INSPECTION SYSTEM DIGITAL CAMR (IDC) (Continued)

### RECONFIGURATION OF A31p SCREEN RESOLUTION (Concluded)

9. 'Display Properties' Dialog Box
  - Sel 'Settings'
  - Move Screen Area slidebar to 1600 x 1200
  - √Colors – True Color (32 bit)
  - If not, sel True Color (32 bit) from drop down menu
  - Sel 'Apply'
  - When 'Display Properties' dialog box opens:
    - Sel 'OK'
  - When 'Monitor Settings' dialog box opens:
    - Sel 'Yes' (within 15 sec)
    - If 15 sec window missed:
      - Repeat step 9
  - When 'Display Properties' dialog box opens:
    - Sel 'OK'

This Page Intentionally Blank

BATTS & FUSES

PAGE

BATT/FUSE REFERENCE..... 21-2

## BATTS & FUSES

### BATTS & FUSES

#### BATT/FUSE REFERENCE

ITEM	BATTERY	SAME AS:	FUSE	SAME AS:	
AVIU	NONE	N/A	2A (1/8 x 1/2)	ET A-B Converter	
BINOCULARS – 14 X40 GYRO – 10 X40 GYRO	AA (6)	CC Remote ET A-B Converter NIKON FLASH	NONE	N/A	
BPSMU	18V (two 9V)	NONE	NONE	N/A	
CAMCORDER – G1	Li-ION	RECORDER – V10 WORKLIGHT	NONE	N/A	
CC Batt Charger	N/A	N/A	3A (Instrument)		
CC Remote	AA(2)	GYRO BINOCULARS ET A-B Converter NIKON FLASH	NONE	N/A	
D2Xs	EN-EL4A	NONE	N/A	N/A	
D2Xs (Date Time)	CR 1616	NONE	NONE	NONE	
DTV (MUX)	NONE	NONE	5A		
DTV (VIP)	NONE	NONE	2A (Instrument) 5A (Instrument)	SSV	
ET A-B CONVERTER	AA (4)	CC Remote NIKON FLASH GYRO BINOCULARS	2A (1/8 x 1/2)	AVIU	
LAVALIER MIC	76 (1)	NONE	NONE	NONE	
NIKON FLASH	AA (4)	CC Remote GYRO BINOCULARS ET A-B Converter	NONE	N/A	
RECORDER – V10	Li-ION	CAMCORDER – G1 WORKLIGHT	NONE	N/A	
SEQUENTIAL STILL VIDEO ENCODER	N/A	N/A	2A (Instrument)	NONE	
WORKLIGHT	Li-ON (2)	CAMCORDER – G1 RECORDER V-10		NONE	
INSTRUMENT FUSES		IFM FUSE KITS		BUS FUSES (1/4 X 1-1/4)	
1/2 A(2)	5A (5)	DTV FUSES		1/4A (2)	3A (2)
1A (5)	7.5A (2)	2A (3)		1/2A (2)	5A (5)
2A (2)	10A (2)	2A (5)		1A (2)	7.5A (2)
3A (5)				2A (2)	10A (2)

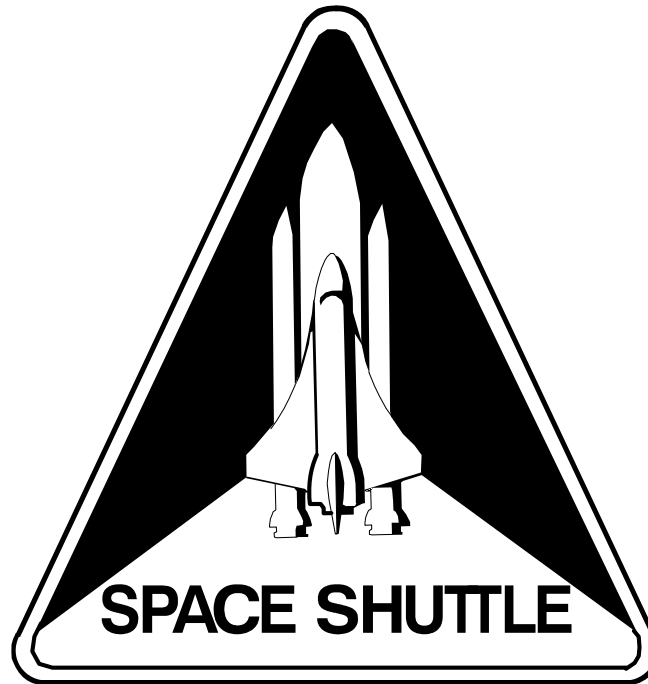

**PHOTO/TV  
CHECKLIST**

**STS  
ALL**