

Photo/TV Checklist

STS-131 Flight Supplement

**Mission Operations Directorate
Operations Division**

**Final
November 6, 2009**

National Aeronautics and
Space Administration

Lyndon B. Johnson Space Center
Houston, Texas



PHOTO/TV C/L, STS-131 Flt Suppl	FINAL (Nov 6, 2009)
---------------------------------	---------------------

PCN-3 (Feb 23, 2010) Sheet 1 of 1

List of Implemented Change Requests (482s):

P/TV_FS-0121

Incorporate the following:

1. Replace FS iii thru FS viii
2. Replace FS 1-5 thru FS 1-10, FS 1-45 and FS 1-46, FS 1-57 and FS 1-58, FS 1-73 and FS 1-74
3. Replace FS 2-21 and FS 2-22
4. Replace FS CC 3-19 and FS CC 3-20

Prepared by: *David Welton* Mission Lead *May Ellen Bruce* Publication Manager

Approved by: *David Welton* Lead, Shuttle Photo/TV Group *Timberly Johnson* Manager, Flight Procedures

Accepted by: *Michael T. ...* FDF Manager

Encl: 22 pages

File this PCN immediately behind the front cover as a permanent record

PHOTO/TV C/L, STS-131 Flt Suppl

FINAL (Nov 6, 2009)

PCN-2 (Feb 18, 2010) Sheet 1 of 1

List of Implemented Change Requests (482s):

P/TV_FS-0119

Incorporate the following:

1. Replace FS iii thru FS viii
2. Replace FS 1-3 thru FS 1-6, FS 1-11 thru FS 1-14, FS 1-17 and FS 1-18, FS 1-21 thru FS 1-24, FS 1-27 and FS 1-28, FS 1-39 thru FS 1-42, FS 1-47 and FS 1-48, FS 1-53 thru FS 1-56, FS 1-58a and FS 1-58b, FS 1-63 and FS 1-64, FS 1-71 thru FS 1-74
3. Replace FS 2-1 thru FS 2-6, FS 2-17 and FS 2-18, FS 2-21 and FS 2-22
After FS 2-28, add FS 2-29 thru FS 2-44 (16 pages)
4. Replace FS CC 3-7 and FS CC 3-8, FS CC 3-17 thru FS CC 3-20, FS CC 3-25 and FS CC 3-26

Prepared by:

Mission Lead
Publication Manager

Approved by:

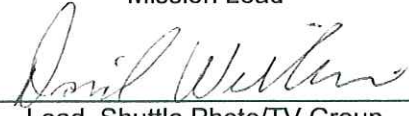
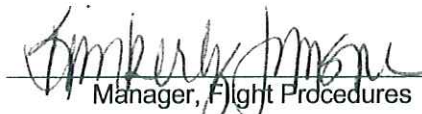
Lead, Shuttle Photo/TV Group
Manager, Flight Procedures

Accepted by:

FDF Manager

Encl: 74 pages

File this PCN immediately behind the front cover as a permanent record

PHOTO/TV C/L, STS-131 Flt Suppl

FINAL (Nov 6, 2009)

PCN-1 (Jan 14, 2010) Sheet 1 of 1

List of Implemented Change Requests (482s):

P/TV_FS-0110

P/TV_FS-0115

Incorporate the following:

1. Replace FS iii thru FS viii
2. Replace FS 1-3 thru FS 1-6, FS 1-43 thru FS 1-46, FS 1-49 thru FS 1-52, FS 1-57 and FS 1-58
After FS 1-58, add FS 1-58a and FS 1-58b
Replace FS 1-59 thru FS 1-62, FS 1-65 and FS 1-66, FS 1-73 thru FS 1-76, FS 1-79 thru FS 1-82
3. Replace FS 2-21 thru FS 2-24
4. Replace FS CC 3-3 and FS CC 3-4, FS CC 3-7 and FS CC 3-8

Prepared by:

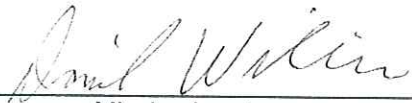
Mission Lead
Publication Manager

Approved by:

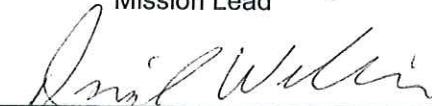
Lead, Shuttle Photo/TV Group
Manager, Flight Procedures

Accepted by:

FDF Manager

Encl: 44 pages

File this PCN immediately behind the front cover as a permanent record

MISSION OPERATIONS DIRECTORATE

**PHOTO/TV CHECKLIST
STS-131 FLIGHT SUPPLEMENT**

FINAL
November 6, 2009

PREPARED BY:



David L. Williams
Mission Lead

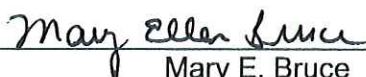

Mary E. Bruce
Publication Manager

APPROVED BY:

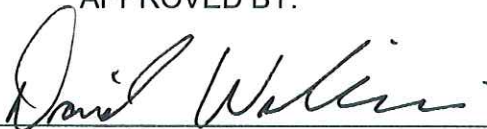

David L. Williams
Technical Lead, Shuttle Photo/TV Group



Carolyn Rosucci
Manager, Flight Procedures

ACCEPTED BY:



Michael T. Hurt
FDF Manager

This document is under the configuration control of the Crew Procedures Control Board (CPCB). All proposed changes must be submitted via Change Request Workflow (CRW) to DO3/FDF Manager.

Additional distribution of this book, for official use only, may be requested in writing to DO3/PMO Administrator. The request must include justification and requester's name, organization, position, and phone number. Contractor requests are made through the NASA or DOD organization supported. Deletions, reduction in quantity, or change of address may be submitted to DO3/FDF Management Office, 281-244-1184.

Incorporates the following:
482#: P/TV_FS-0109

AREAS OF TECHNICAL RESPONSIBILITY

Publication Manager	DO35/M. Bruce	281-483-6083
Alternate Publication Manager	DO35/L. Giles	281-244-9068
Mission Lead	DX46/D. Williams	281-244-7882
Backup Mission Lead	DX46/G. Kilgo	281-244-7926
Technical Lead, Shuttle Photo/TV Group	DX46/D. Williams	281-244-7882

PHOTO/TV CHECKLIST
STS-131 FLIGHT SUPPLEMENT

LIST OF EFFECTIVE PAGES

FINAL 11/06/09
PCN-1 01/14/10
PCN-2 02/18/10
PCN-3 02/23/10

Sign Off	*	131/FIN	FS 1-36.....	131/FIN
FS ii	*	131/FIN	FS 1-37.....	131/FIN
FS iii	*	131/FIN 3	FS 1-38.....	131/FIN
FS iv	*	131/FIN 3	FS 1-39.....	131/FIN
FS v	*	131/FIN 3	FS 1-40.....	⊗ 131/FIN 2
FS vi	*	131/FIN 3	FS 1-41.....	⊗ 131/FIN 2
FS vii	*	131/FIN 3	FS 1-42.....	131/FIN 2
FS viii	*	131/FIN	FS 1-43.....	131/FIN 1
FS ix		131/FIN	FS 1-44.....	131/FIN
FS x		131/FIN	FS 1-45.....	131/FIN 1
1-i		generic	FS 1-46.....	131/FIN 3
1-ii		generic	FS 1-47.....	131/FIN
FS 1-1		131/FIN	FS 1-48.....	⊗ 131/FIN 2
FS 1-2		131/FIN	FS 1-49.....	131/FIN 1
FS 1-3		131/FIN	FS 1-50.....	131/FIN 1
FS 1-4	⊗	131/FIN 2	FS 1-51.....	131/FIN 1
FS 1-5		131/FIN 1	FS 1-52.....	131/FIN
FS 1-6		131/FIN 3	FS 1-53.....	131/FIN
FS 1-7		131/FIN	FS 1-54.....	⊗ 131/FIN 2
FS 1-8		131/FIN 3	FS 1-55.....	131/FIN
FS 1-9		131/FIN 3	FS 1-56.....	131/FIN 2
FS 1-10		131/FIN	FS 1-57.....	131/FIN
FS 1-11		131/FIN 2	FS 1-58.....	131/FIN 3
FS 1-12		131/FIN	FS 1-58a.....	131/FIN 2
FS 1-13		131/FIN	FS 1-58b.....	131/FIN 2
FS 1-14	⊗	131/FIN 2	FS 1-59.....	131/FIN
FS 1-15		131/FIN	FS 1-60.....	131/FIN 1
FS 1-16		131/FIN	FS 1-61.....	131/FIN
FS 1-17		131/FIN	FS 1-62.....	131/FIN 1
FS 1-18		131/FIN 2	FS 1-63.....	131/FIN 2
FS 1-19		131/FIN	FS 1-64.....	131/FIN
FS 1-20		131/FIN	FS 1-65.....	⊗ 131/FIN 1
FS 1-21		131/FIN 2	FS 1-66.....	131/FIN
FS 1-22		131/FIN	FS 1-67.....	131/FIN
FS 1-23		131/FIN	FS 1-68.....	131/FIN
FS 1-24	⊗	131/FIN 2	FS 1-69.....	131/FIN
FS 1-25		131/FIN	FS 1-70.....	131/FIN
FS 1-26		131/FIN	FS 1-71.....	131/FIN 2
FS 1-27		131/FIN	FS 1-72.....	131/FIN
FS 1-28		131/FIN 2	FS 1-73.....	131/FIN 3
FS 1-29		131/FIN	FS 1-74.....	131/FIN
FS 1-30		131/FIN	FS 1-75.....	131/FIN
FS 1-31		131/FIN	FS 1-76.....	131/FIN 1
FS 1-32		131/FIN	FS 1-77.....	131/FIN
FS 1-33		131/FIN	FS 1-78.....	131/FIN
FS 1-34	⊗	131/FIN	FS 1-79.....	131/FIN 1
FS 1-35		131/FIN	FS 1-80.....	131/FIN

* – Omit from flight book

⊗ – Flight copies of this page contain color

FS 1-81	131/FIN	FS CC 3-11.....	131/FIN
FS 1-82	131/FIN 1	FS CC 3-12.....	131/FIN
FS 2-1	131/FIN 2	FS CC 3-13.....	⊗ 131/FIN
FS 2-2	131/FIN	FS CC 3-14.....	131/FIN
FS 2-3	131/FIN	FS CC 3-15.....	131/FIN
FS 2-4	131/FIN 2	FS CC 3-16.....	⊗ 131/FIN
FS 2-5	131/FIN	FS CC 3-17.....	⊗ 131/FIN
FS 2-6	131/FIN 2	FS CC 3-18.....	⊗ 131/FIN 2
FS 2-7	131/FIN	FS CC 3-19.....	⊗ 131/FIN
FS 2-8	131/FIN	FS CC 3-20.....	⊗ 131/FIN 3
FS 2-9	131/FIN	FS CC 3-21.....	131/FIN
FS 2-10	131/FIN	FS CC 3-22.....	⊗ 131/FIN
FS 2-11	131/FIN	FS CC 3-23.....	⊗ 131/FIN
FS 2-12	⊗ 131/FIN	FS CC 3-24.....	131/FIN
FS 2-13	131/FIN	FS CC 3-25.....	131/FIN 2
FS 2-14	131/FIN	FS CC 3-26.....	⊗ 131/FIN
FS 2-15	131/FIN	FS CC 3-27.....	131/FIN
FS 2-16	131/FIN	FS CC 3-28.....	131/FIN
FS 2-17	131/FIN	FS 3-29 (4 pgs).....	Δ 131/FIN
FS 2-18	131/FIN 2	FS 3-30 (4 pgs).....	Δ 131/FIN
FS 2-19	131/FIN	4-i.....	generic
FS 2-20	131/FIN	4-ii.....	generic
FS 2-21	131/FIN	4-1	† generic
FS 2-22	⊗ 131/FIN 3	4-2	† generic
FS 2-23	131/FIN 1	4-3	† generic
FS 2-24	131/FIN 1	4-4	† generic
FS 2-25	131/FIN	4-5	†⊗ generic
FS 2-26	⊗ 131/FIN	4-6	†⊗ generic
FS 2-27	131/FIN	4-7	†⊗ generic
FS 2-28	131/FIN	4-8	† generic
FS 2-29	131/FIN 2	4-9	† generic
FS 2-30	131/FIN 2	4-10	† generic
FS 2-31	131/FIN 2	4-11	† generic
FS 2-32	131/FIN 2	4-12	† generic
FS 2-33	131/FIN 2	4-13	† generic
FS 2-34	131/FIN 2	4-14	† generic
FS 2-35	⊗ 131/FIN 2	4-15	† generic
FS 2-36	131/FIN 2	4-16	† generic
FS 2-37	131/FIN 2	4-17	† generic
FS 2-38	131/FIN 2	4-18	† generic
FS 2-39	131/FIN 2	4-19	† generic
FS 2-40	⊗ 131/FIN 2	4-20	† generic
FS 2-41	⊗ 131/FIN 2	4-21	† generic
FS 2-42	⊗ 131/FIN 2	4-22	†⊗ generic
FS 2-43	131/FIN 2	4-23	†⊗ generic
FS 2-44	131/FIN 2	4-24	†⊗ generic
FS 3-1	131/FIN	4-25	†⊗ generic
FS 3-2	131/FIN	4-26	†⊗ generic
FS CC 3-3	131/FIN	4-27	†⊗ generic
FS CC 3-4	131/FIN 1	4-28	†⊗ generic
FS CC 3-5	131/FIN	4-29	† generic
FS CC 3-6	⊗ 131/FIN	4-30	† generic
FS CC 3-7	131/FIN	4-31	† generic
FS CC 3-8	131/FIN 2	4-32	† generic
FS CC 3-9	131/FIN	4-33	† generic
FS CC 3-10	131/FIN	4-34	† generic

⊗ – Flight copies of this page contain color

Δ – Replace with blue K-10 card stock in flight book only

† – May be replaced with CD in flight book only

4-35	†	generic	7-11	†	generic
4-36	†	generic	7-12	†	generic
4-37	†	generic	7-13	†	generic
4-38	†	generic	7-14	†	generic
5-1	†	generic	7-15	†⊗	generic
5-2	†	generic	7-16	†	generic
5-3	†	generic	7-17	†	generic
5-4	†	generic	7-18	†	generic
5-5	†	generic	7-18a	†	generic
5-6	†	generic	7-18b	†	generic
5-7	†⊗	generic	7-19	†	generic
5-8	†⊗	generic	7-20	†	generic
5-9	†⊗	generic	7-21	†	generic
5-10	†	generic	7-22	†	generic
5-11	†	generic	7-23	†⊗	generic
5-12	†	generic	7-24	†⊗	generic
5-13	†⊗	generic	8-1	†	generic
5-14	†⊗	generic	8-2	†	generic
5-15	†⊗	generic	8-3	†	generic
5-16	†⊗	generic	8-4	†	generic
5-17	†	generic	8-5	†	generic
5-18	†	generic	8-6	†	generic
5-19	†	generic	9-1	†	generic
5-20	†	generic	9-2	†	generic
5-21	†	generic	9-3	†⊗	generic
5-22	†	generic	9-4	†⊗	generic
5-23	†	generic	10-1	†	generic
5-24	†	generic	10-2	†	generic
6-1	†	generic	10-3	†	generic
6-2	†	generic	10-4	†	generic
6-3	†	generic	10-5	†	generic
6-4	†	generic	10-6	†⊗	generic
6-5	†⊗	generic	10-7	†	generic
6-6	†⊗	generic	10-8	†	generic
6-7	†	generic	10-9	†	generic
6-8	†	generic	10-10	†	generic
6-9	†	generic	10-11	†	generic
6-10	†	generic	10-12	†	generic
6-11	†	generic	10-13	†	generic
6-12	†	generic	10-14	†	generic
6-13	†	generic	10-15	†	generic
6-14	†	generic	10-16	†	generic
6-15	†	generic	10-17	†	generic
6-16	†	generic	10-18	†	generic
6-17	†	generic	10-19	†	generic
6-18	†	generic	10-20	†	generic
7-1	†	generic	10-21	†	generic
7-2	†	generic	10-22	†	generic
7-3	†	generic	10-23	†	generic
7-4	†	generic	10-24	†	generic
7-5	†	generic	10-25	†	generic
7-6	†	generic	10-26	†	generic
7-7	†⊗	generic	11-1	†	generic
7-8	†	generic	11-2	†	generic
7-9	†	generic	11-3	†	generic
7-10	†	generic	11-4	†	generic

† – May be replaced with CD in flight book only

⊗ – Flight copies of this page contain color

11-5	†	generic	15-11	†	generic
11-6	†	generic	15-12	†	generic
11-7	†	generic	15-13	†	generic
11-8	†	generic	15-14	†	generic
11-9	†	generic	15-15	†	generic
11-10	†	generic	15-16	†	generic
11-11	†⊗	generic	16-1	†	generic
11-12	†	generic	16-2	†	generic
12-1	†	generic	16-3	†	generic
12-2	†	generic	16-4	†	generic
12-3	†	generic	16-5	†	generic
12-4	†	generic	16-6	†	generic
12-5	†	generic	17-1	†	generic
12-6	†	generic	17-2	†	generic
12-7	†	generic	18-1	†	generic
12-8	†	generic	18-2	†	generic
12-9	†	generic	18-3	†	generic
12-10	†	generic	18-4	†	generic
12-11	†	generic	18-5	†	generic
12-12	†	generic	18-6	†	generic
12-12a	†	generic	19-1	†	generic
12-12b	†	generic	19-2	†	generic
12-13	†	generic	19-3	†	generic
12-14	†⊗	generic	19-4	†	generic
12-15	†	generic	19-5	†	generic
12-16	†	generic	19-6	†	generic
12-17	†	generic	19-7	†	generic
12-18	†	generic	19-8	†	generic
12-19	†	generic	19-9	†	generic
12-20	†	generic	19-10	†	generic
13-1	†	generic	19-11	†	generic
13-2	†	generic	19-12	†	generic
13-3	†	generic	20-1	†	generic
13-4	†⊗	generic	20-2	†	generic
13-5	†⊗	generic	20-3	†	generic
13-6	†⊗	generic	20-4	†	generic
13-7	†⊗	generic	20-5	†	generic
13-8	†⊗	generic	20-6	†	generic
13-9	†	generic	20-7	†	generic
13-10	†	generic	20-8	†	generic
13-11	†	generic	20-9	†	generic
13-12	†	generic	20-10	†	generic
14-1	†	generic	20-11	†	generic
14-2	†	generic	20-12	†	generic
14-3	†	generic	20-13	†	generic
14-4	†	generic	20-14	†	generic
15-1	†	generic	20-15	†⊗	generic
15-2	†	generic	20-16	†	generic
15-3	†	generic	20-17	†	generic
15-4	†	generic	20-18	†⊗	generic
15-5	†	generic	20-19	†	generic
15-6	†	generic	20-20	†	generic
15-7	†	generic	20-21	†	generic
15-8	†	generic	20-22	†	generic
15-9	†	generic	21-1	†	generic
15-10	†	generic	21-2	†	generic

† – May be replaced with CD in flight book only

⊗ – Flight copies of this page contain color

PHOTO/TV CUE CARDS

	<u>Title</u>	<u>Ref. Page</u>	<u>Card No.</u>
TV			
	(Front).....	FS CC 3-3	P/TV-1a/131/O/A
	(Back).....	FS CC 3-4	P/TV-1b/131/O/B
ANALOG PLAYBACK			
	(Front).....	FS CC 3-5	P/TV-2a/131/O/A
	(Back).....	FS CC 3-6	P/TV-2b/131/O/A
ET PHOTO			
	(Front).....	FS CC 3-7	P/TV-3a/131/O/A
	(Back).....	FS CC 3-7	P/TV-3b/131/O/B
MEDIA ALLOCATIONS			
	(Front).....	FS CC 3-8	P/TV-4a/131/O/D
	(Back).....	FS CC 3-9	P/TV-4b/131/O/A
WVS			
	(Front).....	FS CC 3-10	P/TV-5a/131/O/B
	(Back).....	FS CC 3-11	P/TV-5b/131/O/A
PLBD VTR RECORDING			
	(Front).....	FS CC 3-12	P/TV-6a/131/O/A
	(Back).....	FS CC 3-13	P/TV-6b/131/O/A
LDRI/ITVC			
	(Front).....	FS CC 3-14	P/TV-7a/131/O/A
	(Back).....	FS CC 3-15	P/TV-7b/131/O/A
LCS			
	(Front).....	FS CC 3-16	P/TV-8a/131/O/A
	(Back).....	FS CC 3-17	P/TV-8b/131/O/A
IDC			
	(Front).....	FS CC 3-18	P/TV-9a/131/O/B
	(Back).....	FS CC 3-19	P/TV-9b/131/O/A
VIDEO SETUP			
	(Front).....	FS CC 3-20	P/TV-10a/131/O/C
	(Back).....	FS CC 3-21	P/TV-10b/131/O/A
D2Xs SETUP			
	(Front).....	FS CC 3-22	P/TV-11a/131/O/B
	(Back).....	FS CC 3-23	P/TV-11b/131/O/B
LDRI/ITVC A7 PLACARD			
	(Front).....	FS CC 3-24	P/TV-12a/131/O/A
	(Back).....	FS CC 3-24	P/TV-12b/131/O/A
DIGITAL PLAYBACK			
	(Front).....	FS CC 3-25	P/TV-13a/131/O/B
	(Back).....	FS CC 3-26	P/TV-13b/131/O/A
G1 CC SETUP CUE CARD			
	(Front).....	FS CC 3-27	P/TV-17a/131/O/A
	(Back).....	FS CC 3-28	P/TV-17b/131/O/A

This Page Intentionally Blank

TABLE OF CONTENTS

PAGE

FLIGHT SPECIFIC

<u>SCENES</u>	FS 1-1
P/TV01 VIDEO SETUP	FS 1-4
P/TV02 DOCK.....	FS 1-14
P/TV03 UNDOCK.....	FS 1-24
P/TV04 INGRESS/EGRESS	FS 1-34
P/TV05 ISS INTERNAL OPS (HC)	FS 1-40
P/TV06 ROBOTICS OPERATIONS.....	FS 1-48
P/TV07 EVA.....	FS 1-54
P/TV08 EXTERNAL SURVEY	FS 1-60
P/TV09 MIDDECK PAYLOADS	FS 1-70
P/TV10 EPO – ROBOTICS.....	FS 1-76
 <u>REFERENCED PROCEDURES</u>	FS 2-1
 <u>CUE CARD CONFIGURATION</u>	FS 3-1

GENERIC

<u>NIKON D2Xs</u>	4-1
<u>D2Xs EVA CAMR</u>	5-1
<u>EVA IR CAMR</u>	6-1
<u>CANON G1</u>	7-1
<u>SONY V10</u>	8-1
<u>PORTABLE MONITORS</u>	9-1
<u>CCTV</u>	10-1
<u>CENTERLINE (C/L) CAMR</u>	11-1
<u>DTV</u>	12-1
<u>BPSMU</u>	13-1
<u>MINI-CAM</u>	14-1
<u>WIRELESS VIDEO SYSTEM (WVS)</u>	15-1
<u>SEQUENTIAL STILL VIDEO (SSV)</u>	16-1
<u>BINOCULARS</u>	17-1
<u>FIBERSCOPE</u>	18-1
<u>LASER DYNAMIC RANGE IMAGER (LDRI)</u>	19-1
<u>LASER CAMR SYSTEM (LCS)/INTEGRATED SENSOR INSPECTION SYSTEM</u> <u>DIGITAL CAMR (IDC)</u>	20-1
<u>BATTS & FUSES</u>	21-1

This Page Intentionally Blank

SCENES

	<u>PAGE</u>
P/TV01 VIDEO SETUP.....	FS 1-4
P/TV02 DOCK	FS 1-14
P/TV03 UNDOCK	FS 1-24
P/TV04 INGRESS/EGRESS.....	FS 1-34
P/TV05 ISS INTERNAL OPS (HC).....	FS 1-40
P/TV06 ROBOTICS OPERATIONS	FS 1-48
P/TV07 EVA.....	FS 1-54
P/TV08 EXTERNAL SURVEY	FS 1-60
P/TV09 MIDDECK PAYLOADS.....	FS 1-70
P/TV10 EPO – ROBOTICS	FS 1-76

This Page Intentionally Blank

This Page Intentionally Blank

P/TV01 VIDEO SETUP

P/TV01 VIDEO SETUP

H/W SUMMARY

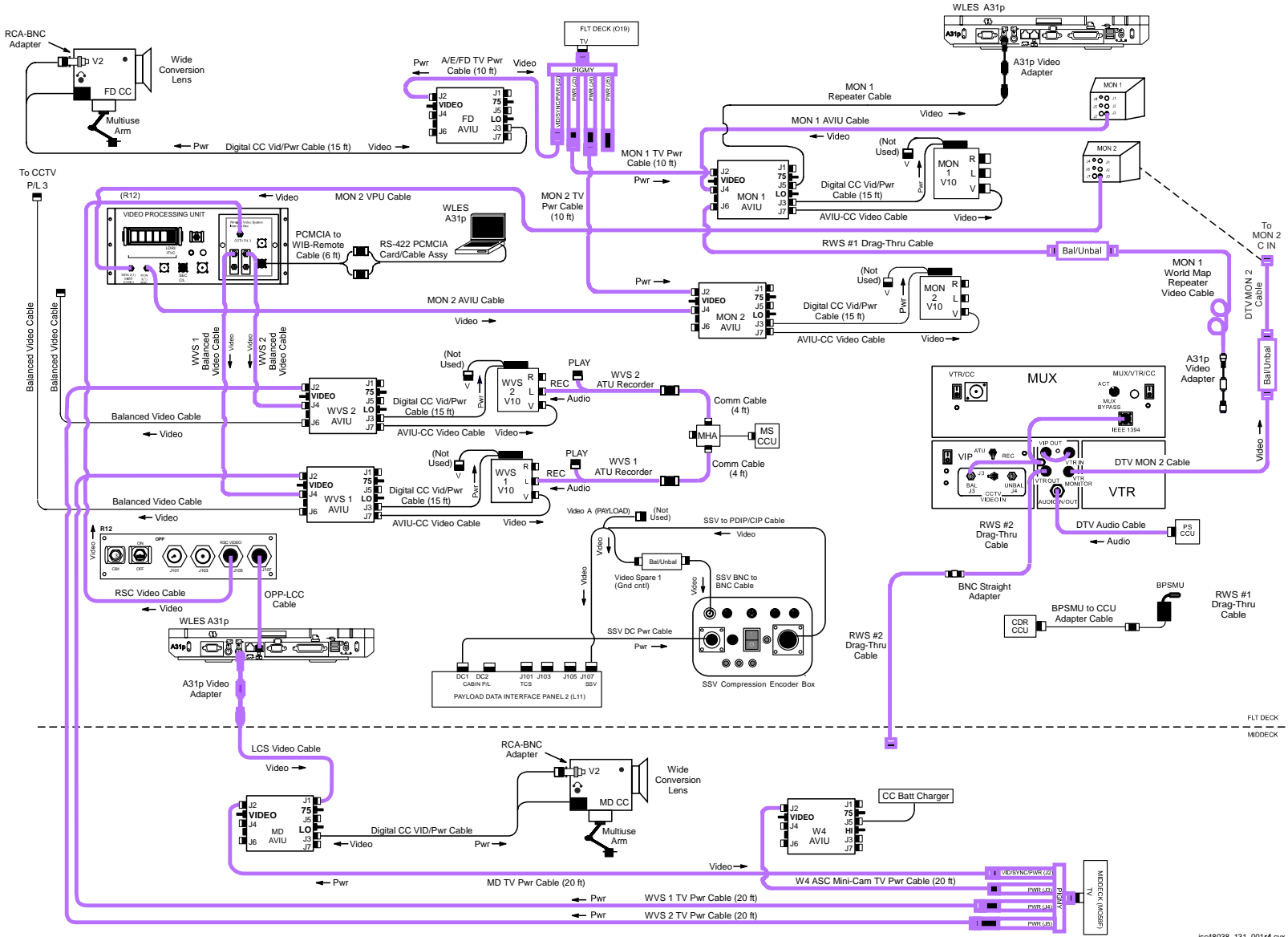

P/TV01 VIDEO SETUP (Continued)

SETUP

NOTE

Steps 1-7 minimum rqmt for OBSS RCC Inspection (focused and post undocked)

1. Perform ACTIVATION, OPERATION (Cue Card, TV) as reqd
2. Perform DTV Setup

O19	<u>Deconfig ASCENT AVIU</u> TV PWR – OFF
L10:A1	Unstow AVIU and disconnect following cables: ASC/ENT/FD TV Pwr Cable from J2 AVIU Adapter Cable from J5 ASC/ENT FD V10 Cable from J1 Temp stow AVIU for use on Flight Deck Config DTV H/W per <u>H/W SUMMARY</u> , FS 1-4
L10 (MUX)	<u>Config Panels</u> √VTR/CC PWR – on (LED on) If dnk: MUX/VTR/CC PWR – on (LED on) √MUX BYPASS – ACT
(VIP)	√ATU – REC √CCTV VIDEO IN – J3 √PWR – on (LED on)
(VTR)	√ON/STANDBY LED – green √Switches set to White Dot (seven) √COUNTER SELECT – COUNTER (TC)
MON 1 MON 2	<u>Config Video</u> SOURCE – DNLK Connect DTV MON 2 Cbl to C-IN SOURCE – C
A15 L9	<u>Config Audio</u> Connect DTV Audio Cable to PS CCU Config PS ATU per Comm Plan

P/TV01 VIDEO SETUP (Continued)

SETUP (Continued)

3. Perform MON 1,2 V10 Setup

MA16D Remove MON 1,2 Desk Assy Hardware from Stow-n-Go CTB

O19 TV PWR – OFF

Config MON 1,2 V10s and Cables per H/W SUMMARY, FS 1-4

Retrieve MON 1 V10 from MS1 Saddlebag

Connect:

MON 1,2 Digital CC Vid/Pwr Cables to MON 1,2 V10s

MON 1,2 AVIU-CC Video Cables to MON 1,2 V10s

Multiuse Brkt to desk

RWS #1 Drag-Thru Cable to MON 1 AVIU J6

MON 1 AVIU Cable to MON 1 AVIU J4

MON 2 AVIU Cable to MON 2 AVIU J4

MON 1,2 TV PWR Cable to MON 1,2 AVIU J2

MON 1 Repeater Cable string to A31p Vid In port

Multiuse Brkt to wall

AVIU (MON 1,2) √SYNC/VIDEO – VIDEO

√HI-Z/75 – 75

√PWR SELECT – LO

R12 (VPU) VPU PWR – ON (LED on)

O19 TV PWR – ON

V10 (MON 1,2) PWR – ON

DISPLAY pb – toggle to display tape counter

√Tape installed

4. √RSC Video Cable connected between R12/OPP-RSC Video (J105) and R12/WIB-CCTV PL3

P/TV01 VIDEO SETUP (Continued)

SETUP (Continued)

5. Perform Analog Camcorder Setup for FD,MD

O19,MO58F TV PWR – OFF
Config G1 CCs per H/W SUMMARY, FS 1-4, as reqd

AVIU (FD,MD) SYNC/VIDEO – VIDEO
HI-Z/75 – 75
PWR SELECT – LO

O19,MO58F TV PWR – ON

CC (FD,MD) Install Wide Conversion lens
√ND FILTER – OFF
√OUTPUT – CAM
√.. –
√STANDBY/LOCK – STANDBY
PWR dial – “green”
√Tape installed
√Viewfinder (LCD) displays “green” •||
Install Audio Muting Plug (optional)
Install Multiuse Brkt

6. Perform LCS Cable Connections per H/W SUMMARY, FS 1-4, as reqd

Middeck AVIU (MD) Connect MD TV Pwr Cable to MD AVIU J2
Connect end of LCS Video Cable to MD AVIU J1
√HI-Z/75 – 75

Flt Deck Connect other end of LCS Video Cable (A31p Video Adapter) to A31p Video Out port via PGSC Usage Chart
Connect OPP-LCC Cable to A31p RJ45 Ethernet port via PGSC Usage Chart

P/TV01 VIDEO SETUP (Continued)

SETUP (Continued)

7. Perform SSV Setup

MA16N Unstow:
 SSV Compression Encoder Box
 SSV BNC-BNC Cable
 SSV to PDIP/CIP Cable
 SSV DC Pwr Cable
 Bal/Unbal Xfmr

Config SSV H/W per H/W SUMMARY, FS 1-4

NOTE

Video Spare 1 controlled by MCC instead of pnl A7

L12 (SSP 2) √cb PDIP 2 PWR 1 – cl
L11 (PDIP 2) DC PWR 1 – ON

SSV Config SSV settings
 IN SEL – NTSC
 Mode – 3
 OUTRATE – 4
 SSV Pwr – on
 √Pwr LED illum
 √ENC DATA LED flickering
 √FRM DATA LED flickering
 √FILL FRM pulsing

Inform MCC when SSV SETUP complete

8. Perform HDTV Setup for handheld ET Video Downlink

L10:A1 Unstow MPC
 White Brick
 MPC-DTV MUX Cbl (Fiber Optic)
MA16D/Stow-n-Go MPC-G1 Cbl (Firewire)

Config H/W per diagram on back of HD DIGITAL VIA CC PLAYBACK Cue Card

FS 1-8

P/TV01 VIDEO SETUP (Continued)

SETUP (Continued)

9. Perform WVS Setup

a. Activate WVS System

A7 WIRELESS VID HTR – ON
PWR – ON

MO58F TV PWR – OFF

MA16D b. Remove WVS Hardware from Stow-n-Go CTB

Config WVS 1,2 V10s and Cables per H/W SUMMARY, FS 1-4

Connect:

WVS 1,2 Digital CC Vid/Pwr Cables to WVS 1,2 V10s

WVS 1,2 AVIU-CC Vid Cables to WVS 1,2 V10s

Multiuse Brkt to desk

Pre-routed WVS 1,2 Balanced Video Cables from R12/VPU XCVR 1,2 BAL to WVS 1,2 AVIU J4

Pre-routed WVS TV Pwr Cables to WVS 1,2 AVIU J2

Balanced Video Cables stowed on WVS Stow-n-Go desk to WVS 1,2 AVIU J6

ATU Recorder Cables to left (white) port per H/W SUMMARY, FS 1-4

Multiuse Brkt to wall

PCMCIA-to-WIB Remote Cable to R12/WIB J701

RS-422 PCMCIA Card/Cable Assy and PCMCIA-to-WIB Remote Cable to bottom PCMCIA slot on A31p per

PGSC Usage Chart

AVIU (WVS 1,2) √SYNC/VIDEO – VIDEO
√HI-Z/75 – 75
√PWR SELECT – LO

MO58F V10 (two)
TV PWR – ON
V10 (WVS 1,2) PWR – ON
√Tape installed
√WVS Test Pattern displayed (color bars w/“No WVS Video”)
PWR – OFF

R10 Config MS ATU/CCU per Comm Plan

P/TV01 VIDEO SETUP (Continued)

SETUP (Continued)

9. Perform WVS Setup (Continued)

c. WVS PGSC Prep

PGSC

PGSC Pwrup and Application Opening

√Pwr – ON

Sel Shuttle Apps icon

Sel WVS icon

Sel 'No' at 'Restore To Previous Settings:' window

If 'Comm Port Configuration' error displayed:

Remove Quatech RS-422 Card

Sel 'Start' > 'Shut Down' > 'Shut Down' > 'OK'

Reinstall Quatech RS-422 Card in bottom PCMCIA slot

Pwr – ON

Sel Shuttle Apps icon

Sel WVS icon

RF Camera page will appear

Application Setup

If 'Static XCVR' ('Bad Camera ID', 'Temp Alert', 'Temp Caution') alert msg:

| Perform ALERT MSG TROUBLESHOOTING (Cue Card, WVS)

If 'Static RF Camera' alert msg:

Disregard

Sel 'File' → 'Assign Camera ID'

Verify following:

Camr Address	S/N	In Use	Label
16	1010	1	EV1
18	1007	1	EV2

If Camr IDs not correct:

Sel 'Delete Entry' until all deleted

Perform CAMR ID ASSIGNMENT (Cue Card, WVS) as reqd

When complete, sel 'OK'

P/TV01 VIDEO SETUP (Concluded)

SETUP (Concluded)

9. Perform WVS Setup (Concluded)

c. WVS PGSC Prep (Concluded)

Application Setup (Concluded)

Sel 'File' → 'Advanced Controls'

On XVCR tab:

√IF – selected

√Other options not selected

Sel RF Camera tab:

√Power Selections – selected

√Automatic Gain Control – selected

√S-Band Level – selected

√Other options not selected

When complete, sel 'OK'

d. PWRDN

Sel 'File' → 'Exit'

WIRELESS VID PWR – OFF

HTR – OFF

A7

MA16N 10. Unstow, set up BPSMU w/BPSMU to CCU Adapter Cable at CDR CCU
Connect BPSMU Batt

A17/CC BAG 11. Unstow, connect CC Batt Charger to W4 AVIU J5 port

|

This Page Intentionally Blank

This Page Intentionally Blank

P/TV02 DOCK

P/TV02 DOCK

H/W SUMMARY

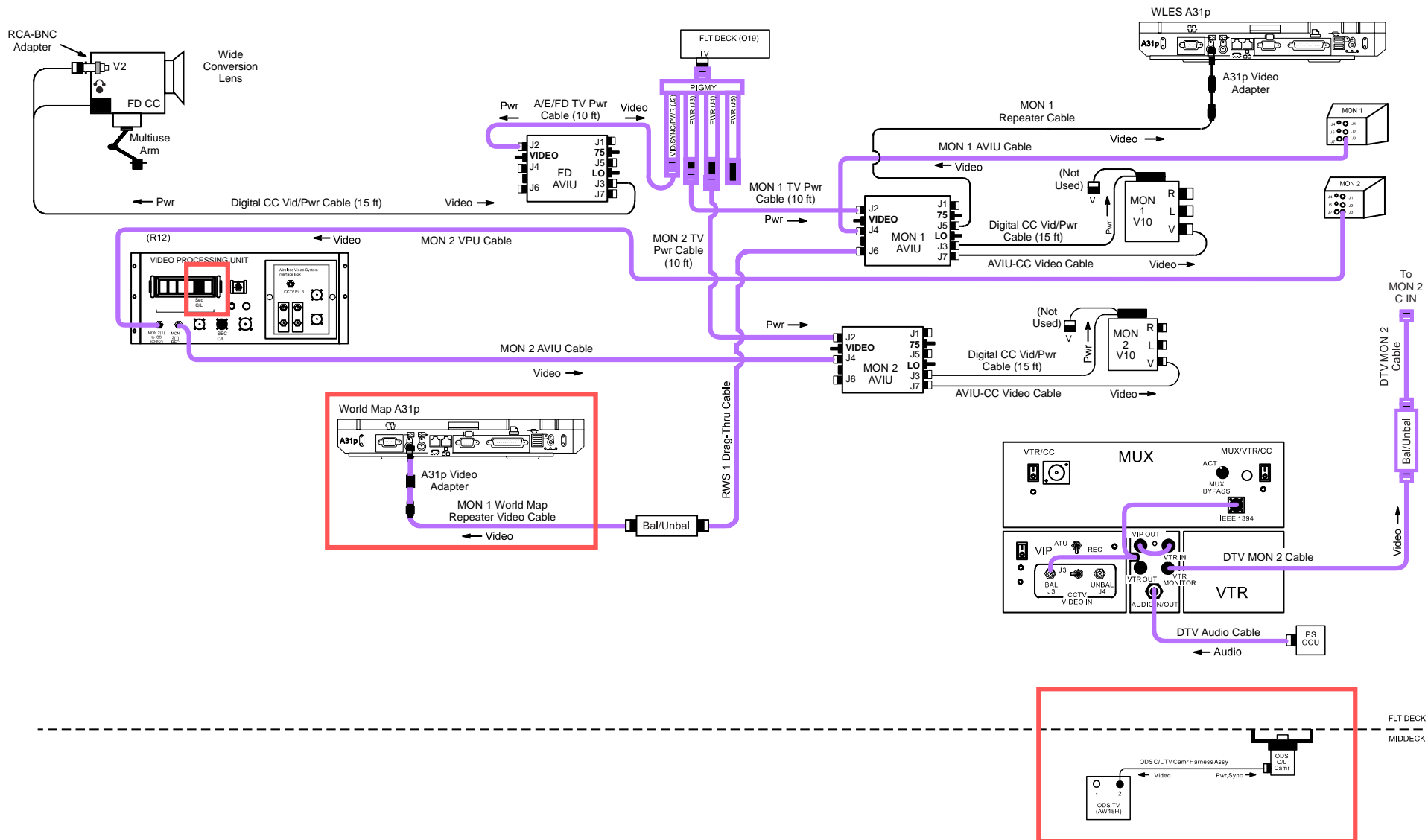

jsc48038_131_002r3.cvx



P/TV02 DOCK (Continued)

SCENE SYNOPSIS

Scene contains procedures for obtaining video, still photos of ISS rndz, docking

SETUP

1. Perform ACTIVATION, OPERATION (Cue Card, TV) as reqd
2. Perform D2Xs PROGRAM w/FLASH for in-cabin imagery

Lens – 12-24mm
Aperture – Min, locked
Body Focus Mode – S
√Batt installed
√Flash Card installed
Pwr – ON
Top LCD:
√Batt
√Frames remaining sufficient
Exp Comp () – 0.0
Exp Mode – P
Meter – Matrix ()
Diopter – Adjust
Frame Rate – S
√BKT disabled – 0 F
Rear LCD:
√ISO – 100
√QUAL – RAW
√WB – 0,A
AF Area Mode – [[]]
√Focus Area – Center
√Focus Selector Lock – L
SB-800 Flash Settings:
ON/OFF pb – ON
√Diffuser Dome installed
√MODE –  TTL BL
√Exp Comp – 0 EV
Tilt – 45° (Direct)

P/TV02 DOCK (Continued)

SETUP (Continued)

3. Perform D2Xs MANUAL for docking/external imagery

Remove ovhd window shields

SB-800 Flash Settings:
ON/OFF pb – OFF

Lens – 400mm(80-200mm)

If 400mm:

| Focus Limit – ∞ -6m
| Lens Focus Mode – A

If 80-200mm:

Focus Limit – full
Lens Focus Mode – A

Aperture – Min, locked

Body Focus Mode – S

√Batt installed

√Flash Card installed

Pwr – ON

Top LCD:

√Batt

√Frames remaining sufficient

Exp Comp () – 0.0

Exp Mode – M:

SS – 500

f/stop – 8

Meter – Matrix ()

Diopter – Adjust

Frame Rate – S

√BKT disabled – 0 F

Rear LCD:

√ISO – 100

√QUAL – RAW

√WB – 0,A

AF Area Mode – [[]]

√Focus Area – Center

√Focus Selector Lock – L

P/TV02 DOCK (Continued)

SETUP (Continued)

4. Perform Hardware Verification for V10s, FD CC, DTV

- O19 √TV PWR – ON
- R12 (VPU) √VPU PWR – ON (LED on)
 √Green Jumper – SEC C/L
 √SEC C/L Cap installed
- V10
(MON 1,2) PWR – ON

 √Tape installed
 DISPLAY pb – Toggle to display tape counter
- CC For in-cabin views:
 √Wide Conversion lens installed
 √ND FILTER – OFF
 √OUTPUT – CAM
 √..-
 √STANDBY/LOCK – STANDBY
 PWR dial – “green”
 √Tape installed
 Open LCD:
 √“green” •|| displayed
 Install Audio Muting Plug (optional)

P/TV02 DOCK (Continued)

SETUP (Concluded)

4. Perform Hardware Verification for V10s, FD CC, DTV (Concluded)

CC	For sunlit ISS views: Remove Wide Conversion Lens Install fresh Batt as reqd √ND FILTER – OFF AF/M – M AGC – OFF GAIN – L √OUTPUT – CAM √AWB – ON √ <input type="checkbox"/> .. <input type="checkbox"/> <input type="checkbox"/> - <input type="checkbox"/> <input type="checkbox"/> √STANDBY/LOCK – STANDBY PWR dial – M √Tape installed Open LCD: √“green” • displayed SS – 1/500 √GAIN – 0dB f/stop – F8.0 √FOCUS – M ∞ (adjust as reqd) Install Audio Muting Plug (optional)
R7	Verify World Map A31p per diagram on FS 1-14, with MON 1 World Map Repeater Video Cbl connected to RWS #1 BAL/UNBAL XFMR
MON 2 L10 (MUX) (VIP) (VTR)	SOURCE – C VTR/CC PWR – on (LED on) If dnlk, MUX/VTR/CC PWR – on (LED on) PWR – on (LED on) ON/STANDBY LED – green √Tape installed
A31p	Double click ‘Shuttle Apps’ > ‘NASA Video Overlay’ √‘NASA Video Overlay’ window displayed Sel ‘Full Screen’ Press ‘ESC’ or ‘W’ key to minimize display as reqd

P/TV02 DOCK (Continued)

OPS

√	Item # Track #	Rqmts	Still Imagery	Video			Notes
				PLB	CC	Drnk	
	1. 19A-11	PAO Coverage	<u>D2Xs (Interior)</u> 12-24mm If exterior: Flash ON/OFF – OFF	As desired	<u>G1</u> Tape installed	LIVE (if avail)	Plan for end of day crew choice video,DCS
	2. 19A-3	Rendezvous <ul style="list-style-type: none"> • Overall • Closeup • Damage • Deterioration 	<u>D2Xs (Exterior)</u> 400mm(80-200mm) Flash ON/OFF – OFF	<u>A(B,C,D), ELB</u>	<u>G1</u> As desired		Map ISS surfaces w/30% overlap
	3. 19A-3	Approach,Dock <ul style="list-style-type: none"> • PMA2 Docking Target • PMA2 Mating Surfaces • PMA2 TCS Planar and Hemispherical Retro Reflectors 	<u>D2Xs (Exterior)</u> 400mm(80-200mm) Flash ON/OFF – OFF	<u>C/L</u> Per RNDZ <u>A(D)</u> Per RNDZ <u>C(B)</u> Docking view	<u>G1</u> As desired		Rcd C/L Camr video thru hard dock on DTV Continually √focus sharpness

P/TV02 DOCK (Continued)

OPS (Continued)

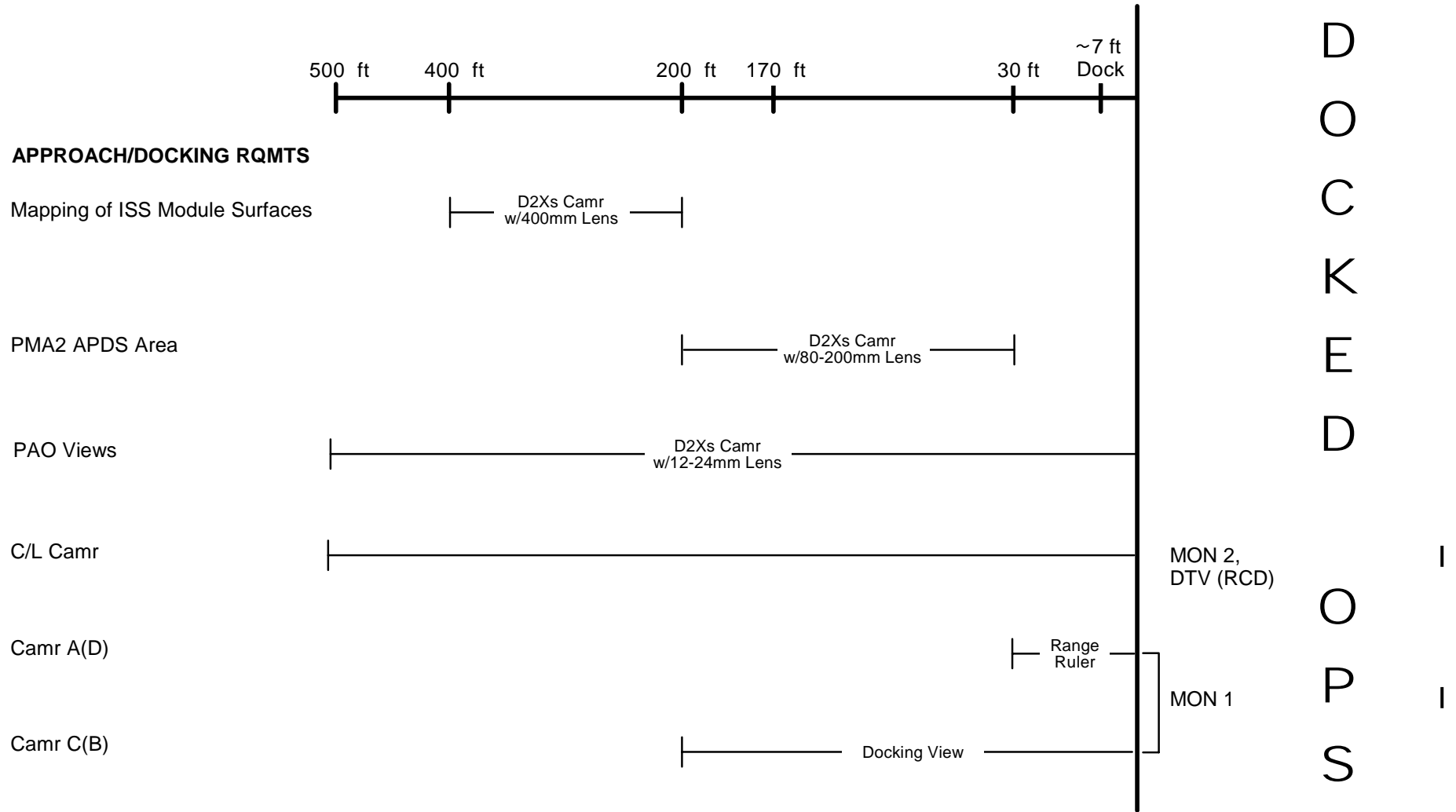

jsc48038_131_003r1.cvx

P/TV02 DOCK (Concluded)

OPS (Concluded)

If OPS temporarily suspended, perform DEACTIVATION as reqd
If OPS completed, go to DEACTIVATION

DEACTIVATION

1. D2Xs
 - √Exp Mode – P
 - Pwr – OFF
 - √Flash ON/OFF – ON

2. TV System
 - R12 (VPU) √Green Jumper – SEC C/L
 - √SEC C/L Cap installed
 - √VPU PWR – ON (LED on)
 - A7 VID OUT MON 1 pb – push
 - IN PL2(VPU) pb – push
 - L12 (SSP 2) CAMR CMD IRIS – CL
 - C/L CAM PWR – OFF
 - ODS Remove, stow C/L camr, Harness Assy, Bridge
 - Go to DEACTIVATION (Cue Card, TV) as reqd
 - R7 Connect RWS #1 Cable to BAL/UNBAL XFMR

3. G1
 - PWR dial – “green”
 - Install Wide Conversion Lens

This Page Intentionally Blank

This Page Intentionally Blank

P/TV03 UNDOCK

P/TV03 UNDOCK

H/W SUMMARY

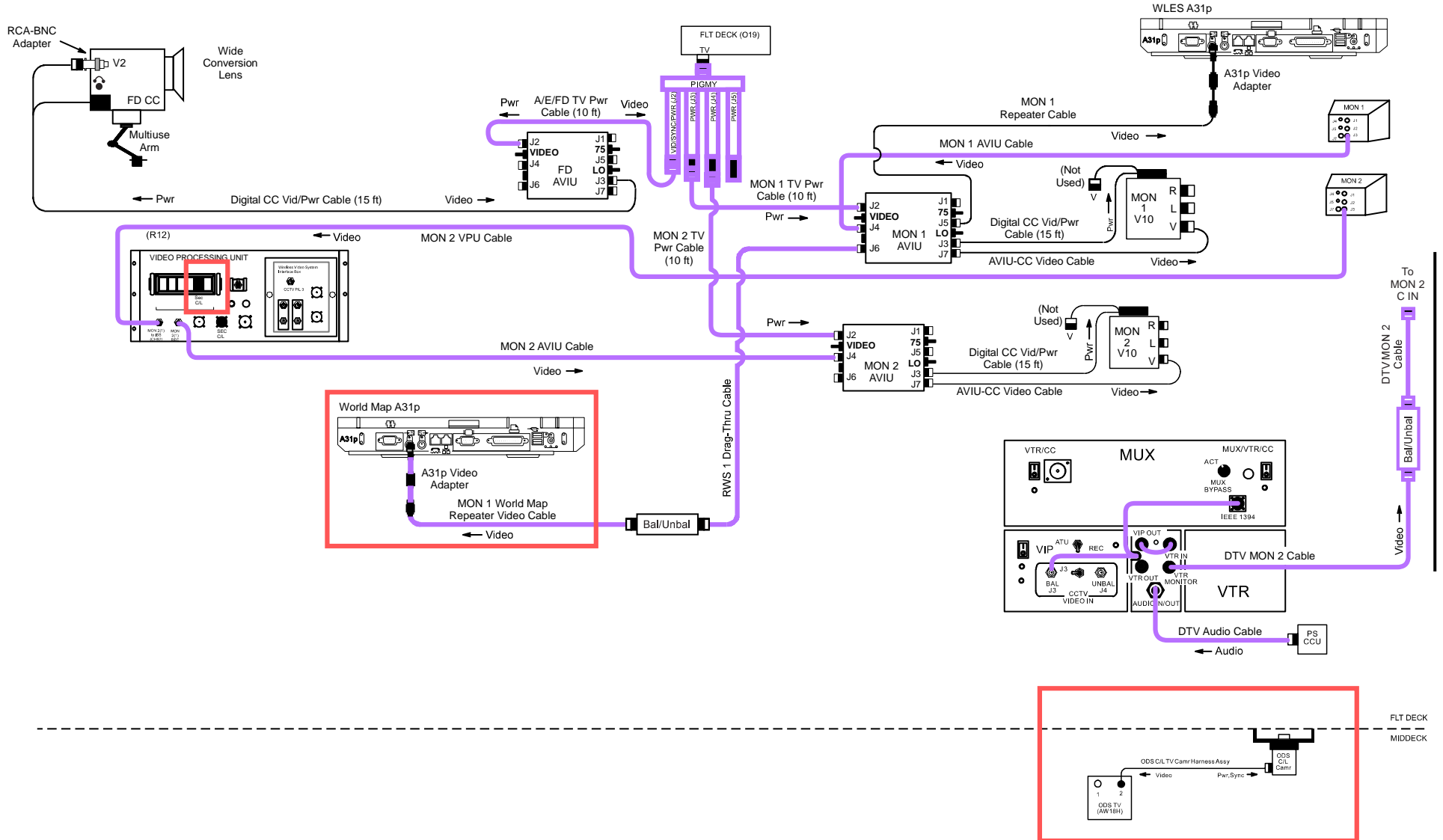

jsc48038_131_002r3.cvx

P/TV03 UNDOCK (Continued)



SCENE SYNOPSIS

Scene contains procedures for obtaining video, still photos of ISS undocking, flyaround

SETUP

1. Perform ACTIVATION, OPERATION (Cue Card, TV) as reqd
2. Perform D2Xs PROGRAM w/FLASH for in-cabin imagery

Lens – 12-24mm
Aperture – Min, locked
Body Focus Mode – S
√Batt installed
√Flash Card installed
Pwr – ON
Top LCD:
√Batt
√Frames remaining sufficient

Exp Comp () – 0.0
Exp Mode – P
Meter – Matrix ()
Diopter – Adjust
Frame Rate – S
√BKT disabled – 0 F
Rear LCD:
√ISO – 100
√QUAL – RAW
√WB – 0,A
AF Area Mode – [[]]
√Focus Area – Center
√Focus Selector Lock – L

SB-800 Flash Settings:
ON/OFF pb – ON
√Diffuser Dome installed
√MODE –  TTL BL
√Exp Comp – 0 EV
Tilt – 45° (Direct)

P/TV03 UNDOCK (Continued)

SETUP (Continued)

3. Perform D2Xs MANUAL for undocking/external imagery

Remove ovhd window shields

SB-800 Flash Settings:
ON/OFF pb – OFF

Lens – 400mm(80-200mm)

If 400mm:

Focus Limit – ∞ -6m
Lens Focus Mode – A

If 80-200mm:

Focus Limit – full
Lens Focus Mode – A

Aperture – Min, locked

Body Focus Mode – S

√Batt installed

√Flash Card installed

Pwr – ON

Top LCD:

√Batt

√Frames remaining sufficient

Exp Comp () – 0.0

Exp Mode – M:

SS – 500

f/stop – 8

Meter – Matrix ()

Diopter – Adjust

Frame Rate – S

√BKT disabled – 0 F

Rear LCD:

√ISO – 100

√QUAL – RAW

√WB – 0,A

AF Area Mode – [[]]

√Focus Area – Center

√Focus Selector Lock – L

P/TV03 UNDOCK (Continued)

SETUP (Continued)

4. Perform Hardware Verification for V10s, FD CC, DTV

- O19 √TV PWR – ON
- R12 (VPU) √VPU PWR – ON (LED on)
 √Green Jumper – SEC C/L
 √SEC C/L Cap installed
- V10
(MON 1,2) PWR – ON

 √Tape installed
 DISPLAY pb – Toggle to display tape counter
- CC For in-cabin views:
 √Wide Conversion lens installed
 √ND FILTER – OFF
 √OUTPUT – CAM
 √.. –
 √STANDBY/LOCK – STANDBY
 PWR dial – “green”
 √Tape installed
 Open LCD:
 √“green” •|| displayed
 Install Audio Muting Plug (optional)

P/TV03 UNDOCK (Continued)

SETUP (Concluded)

4. Perform Hardware Verification for V10s, FD CC, DTV (Concluded)

CC	For sunlit ISS views: Remove Wide Conversion Lens Install fresh Batt as reqd √ND FILTER – OFF AF/M – M AGC – OFF GAIN – L √OUTPUT – CAM √AWB – ON √ <input type="checkbox"/> .. <input type="checkbox"/> - <input type="checkbox"/> √STANDBY/LOCK – STANDBY PWR dial – M √Tape installed Open LCD: √“green” • displayed SS – 1/500 √GAIN – 0dB f/stop – F8.0 √FOCUS – M ∞ (adjust as reqd) Install Audio Muting Plug (optional)
R7	Reconnect Cable String from World Map A31p to RWS #1 BAL/UNBAL XFMR
MON 2 L10 (MUX) (VIP) (VTR)	SOURCE – C VTR/CC PWR – on (LED on) If dnk, MUX/VTR/CC PWR – on (LED on) PWR – on (LED on) ON/STANDBY LED – green √Tape installed
A31p	Double click ‘Shuttle Apps’ > ‘NASA Video Overlay’ √‘NASA Video Overlay’ window displayed Sel ‘Full Screen’ Press ‘ESC’ or ‘W’ key to minimize display as reqd

P/TV03 UNDOCK (Continued)

OPS

√	Item # Track #	Rqmts	Still Imagery	Video			Notes
				PLB	CC	Dnlk	
	1. 19A-11	PAO Coverage	<u>D2Xs (Interior)</u> 12-24mm If exterior: Flash ON/OFF – OFF	As desired	<u>G1</u> Tape installed	LIVE (if avail)	Plan for end of day crew choice video,DCS
	2. 19A-2 19A-3	Undock and Flyaround <ul style="list-style-type: none"> • PMA-2 Docking Tgt/Mating Surfaces • PMA-2 TCS Planar, Hemispherical Retro Reflectors • Surfaces • Solar Panels • Handrails • SM Thrusters on Zenith, near aft end • Trusses including rads/baseplates and SAWs (in/outboard SABB insulation degradation) • SOLAR on Columbus EPF • MISSE-7 on ELC2 on S3 	<u>D2Xs (Exterior)</u> 80-200mm(400mm) Flash ON/OFF – OFF	<u>A(C,D)</u> Per RNDZ <u>C/L</u> Docking tgt and PAO view	<u>G1</u> Tape installed	LIVE (if avail)	Map ISS surfaces w/30% overlap

I

P/TV03 UNDOCK (Continued)

OPS (Continued)

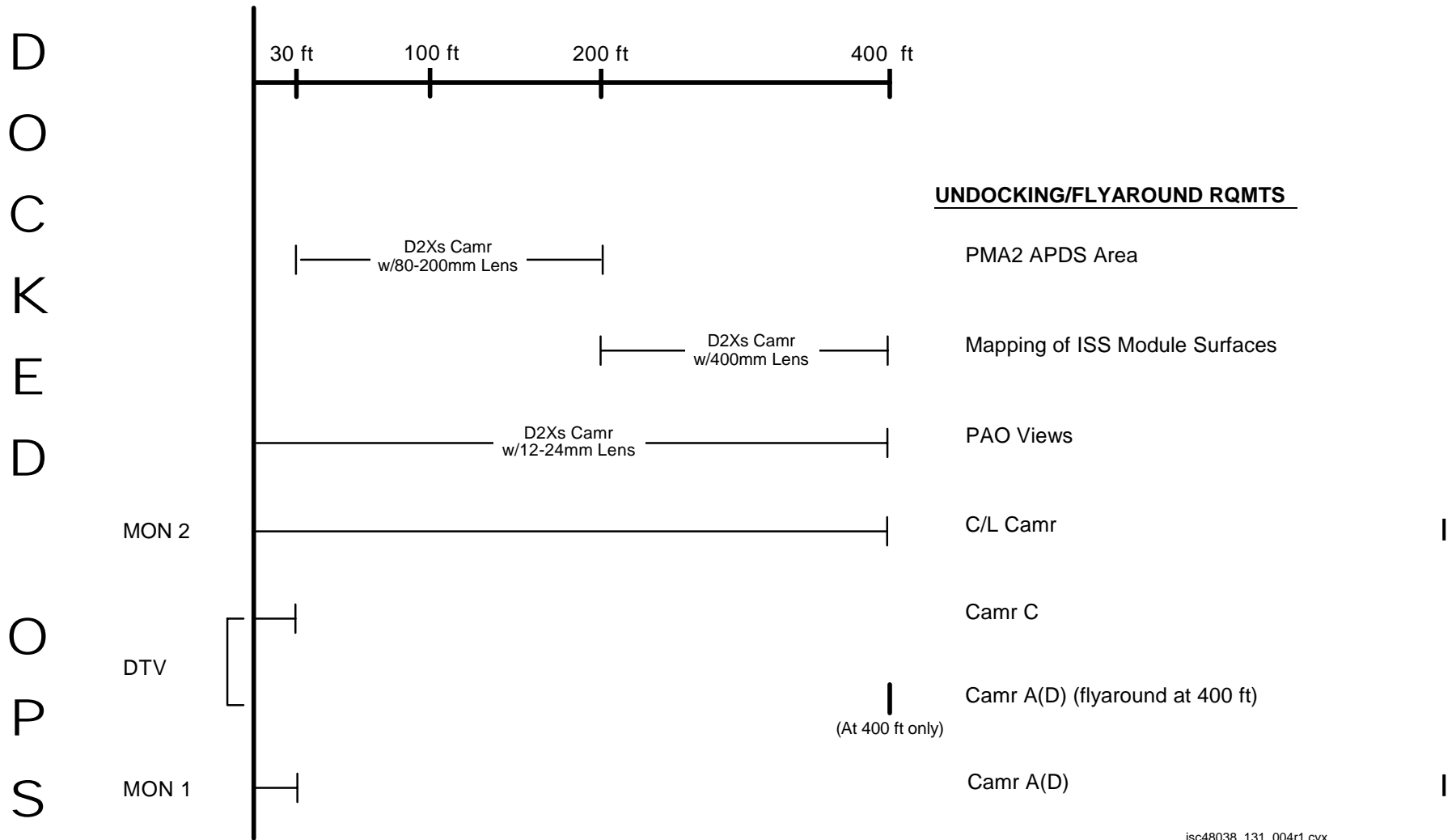

jsc48038_131_004r1.cvx

P/TV03 UNDOCK (Concluded)

OPS (Concluded)

If OPS temporarily suspended, perform DEACTIVATION as reqd
If OPS completed, go to DEACTIVATION

DEACTIVATION

1. D2Xs
 - √Exp Mode – P
 - Pwr – OFF
 - √Flash ON/OFF – ON

2. TV System
 - R12 (VPU) √Green Jumper – SEC C/L
 - √SEC C/L Cap installed
 - √VPU PWR – ON (LED ON)
 - A7U VID OUT MON 1 pb – push
 - IN PL2(VPU) pb – push
 - CAMR CMD IRIS – CL
 - L12 (SSP 2) C/L CAM PWR – OFF

 - ODS Remove, stow C/L Camr, Harness Assy
 - Go to DEACTIVATION (Cue Card, TV) as reqd

3. G1
 - √PWR dial – “green”
 - Install Wide Conversion Lens

This Page Intentionally Blank

This Page Intentionally Blank

P/TV04 INGRESS/EGRESS

H/W SUMMARY

INGRESS TV CONFIG

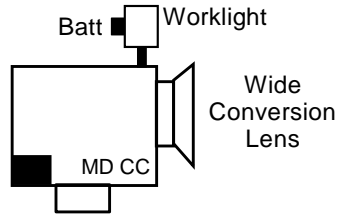

(R12)

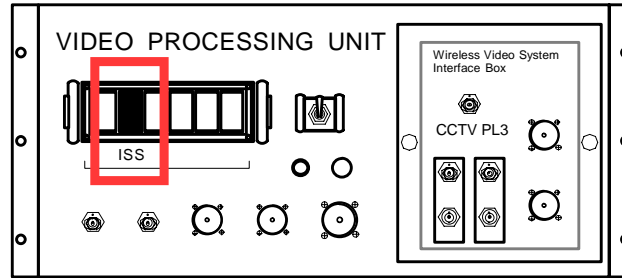

jsc48038_131_005r1.cvx

P/TV04 INGRESS/EGRESS (Continued)

SCENE SYNOPSIS

Scene contains procedures for documenting ISS ingress/egress w/video and still photos

SETUP

1. Config ISS Video

R12 (VPU) Perform ACTIVATION (Cue Card, TV) for DNLK OPS of ISS signal as reqd
Green Jumper – ISS
√VPU PWR – ON

A7 VID OUT DNLK pb – push
IN PL2(VPU) pb – push

2. Perform Ingress Camcorder Setup

Obtain two Batts, one for CC and one spare
Install Batt

CC Install Wide Conversion lens
√ND FILTER – OFF
√OUTPUT – CAM
√... -
√STANDBY/LOCK – STANDBY
PWR dial – “green”
√Tape installed
√Viewfinder (LCD) displays “green” •||
Install Audio Muting Plug (optional)
Install Multiuse Brkt

CAUTION

Due to temp constraints, worklights at full pwr for 60 min; 90% pwr for unlimited time



Worklights Install fresh Batts
Mount light on CC
PWR – as reqd



P/TV04 INGRESS/EGRESS (Continued)

SETUP (Concluded)

3. Perform D2Xs PROGRAM w/FLASH

- Lens – 12-24mm
- √Aperture – Min, locked
- Body Focus Mode – S
- √Batt installed
- √Flash Card installed
- Pwr – ON
- Top LCD:
 - √Batt
 - √Frames remaining sufficient

- Exp Comp () – 0.0
- Exp Mode – P
- Meter – Matrix ()
- Diopter – Adjust
- Frame Rate – S
- √BKT disabled – 0 F
- Rear LCD:
 - √ISO – 100
 - √QUAL – RAW
 - √WB – 0,A
- AF Area Mode – [[]]
- √Focus Area – Center
- √Focus Selector Lock – L

- SB-800 Flash Settings:
 - √Diffuser Dome installed
 - ON/OFF pb – ON
 - √MODE –  TTL  BL
 - √Exp Comp – 0 EV
 - Tilt – 45° (Direct)

P/TV04 INGRESS/EGRESS (Concluded)

OPS

√	Item # Track #	Rqmts	Still Imagery	Video			Notes
				PLB	CC	Dnlk	
	1. 19A-11	Hatch Opening, Ingress Hatch Close, Egress	<u>D2Xs</u> 12-24mm		<u>G1</u>	LIVE (if avail)	

I

If OPS temporarily suspended, perform DEACTIVATION as reqd
 If OPS completed, go to DEACTIVATION

DEACTIVATION

1. D2Xs
Pwr – OFF
2. TV System
Go to DEACTIVATION (Cue Card, TV) as reqd

This Page Intentionally Blank

This Page Intentionally Blank

P/TV05 ISS INTERNAL OPS

H/W SUMMARY

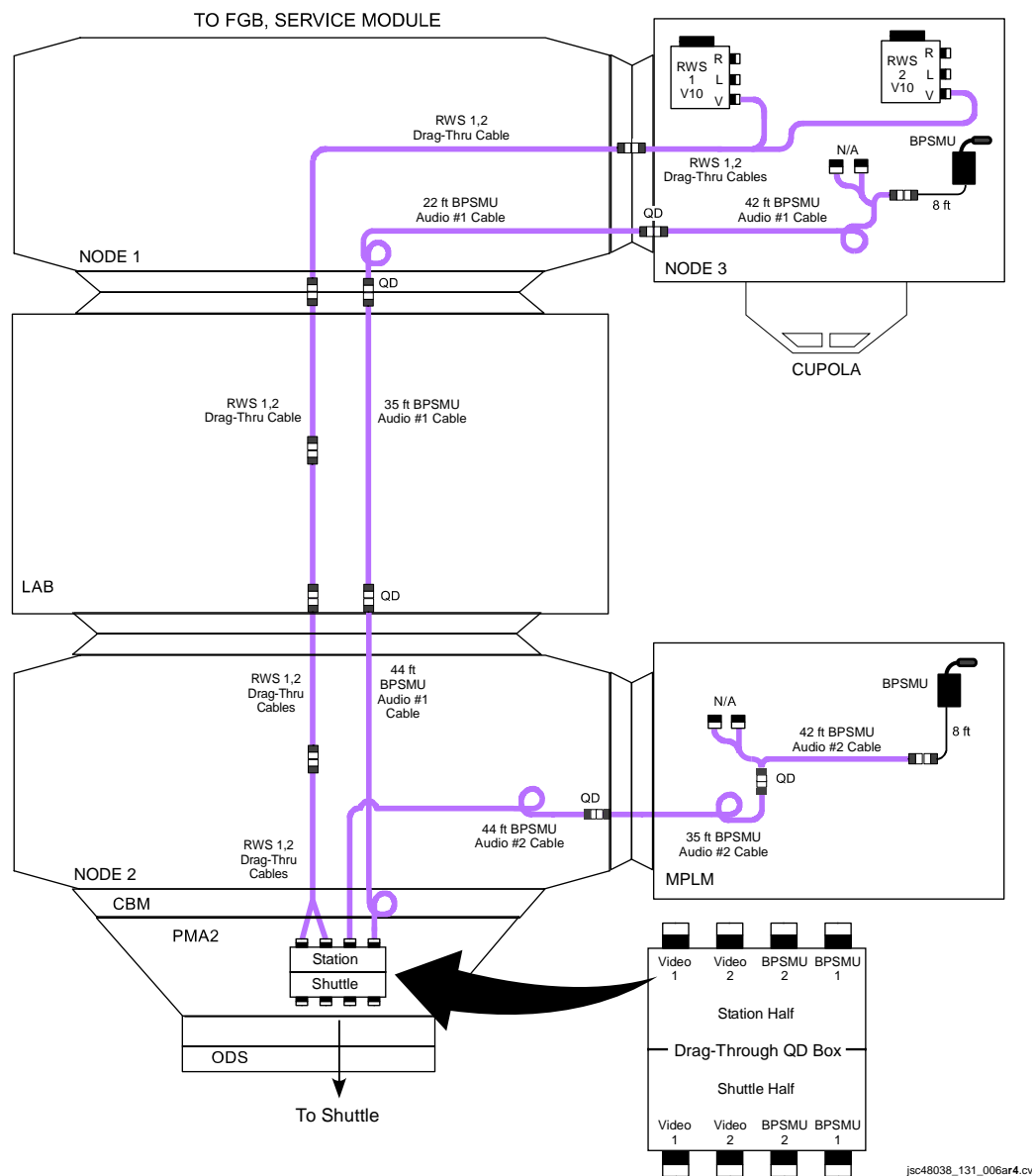

FS 1-40

jsc48038_131_006ar4.cvx

P/TV05 ISS INTERNAL OPS (Continued)

H/W SUMMARY (Concluded)

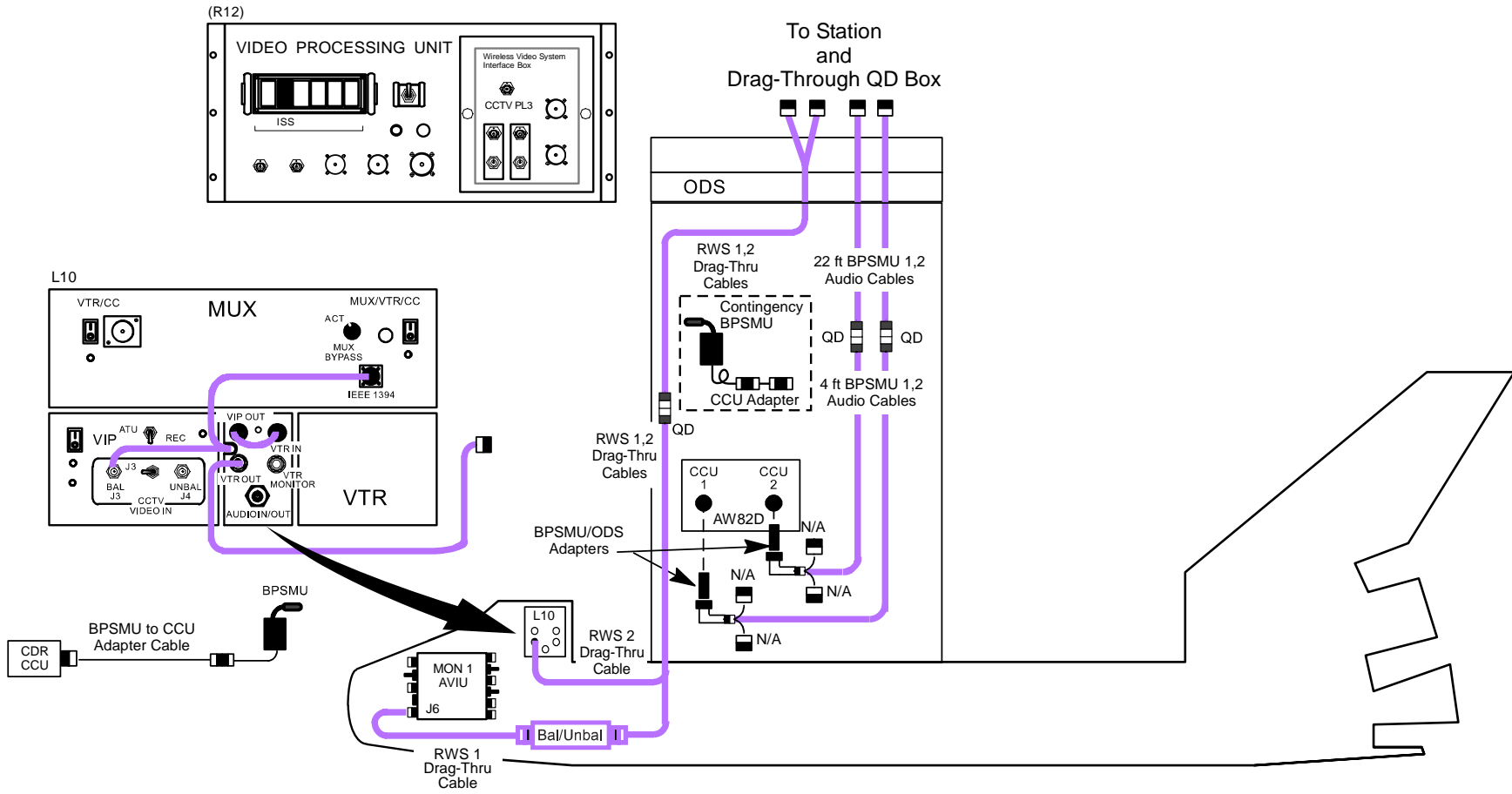

jsc48038_131_006br3.cvx

P/TV05 ISS INTERNAL OPS (Continued)

SCENE SYNOPSIS

Scene contains procedures for setup, documenting ISS internal ops (surveys, PAO events, logistics, transfers, closeouts) w/video, still photos

SETUP

WARNING

Locate QDs at hatches for ease in locating, disconnecting during hatch closure.
Route, restrain cables to prevent loose cable lengths which could entrap crew

BPSMU AND RWS CABLES

1. Config H/W per H/W SUMMARY, FS 1-40 and FS 1-41

MA16N

Retrieve second BPSMU, connect internal battery, temp stow in ODS for contingency use

Config RWS Vid Cables:

MON 1,2

(Stow-n-Go)

√RWS 1 Drag-Thru Cable connected to MON 1 AVIU J6

L10:A1

√RWS 2 Drag-Thru Cable connected to DTV VTR OUT connector

Config BPSMU and RWS Cables:

ODS/PMA2

AW82D

Connect orbiter RWS 1,2 Cables to Drag-Through QD Box

Connect BPSMU Cables to orbiter A/L CCU 1,2 and Drag-Through QD Box

Config A/L ATU per Comm Plan

If V10:

ISS

V10 (RWS 1,2)

√Pwr configured per P/TV121 DOCKED OPERATIONS, dwg USOS 120VDC -V10 VTRs (SODF: ISS PTV: SCENES)

PWR – ON

~

P/TV05 ISS INTERNAL OPS (Continued)

SETUP (Continued)

BPSMU AND RWS CABLES (Concluded)

- A31p
- ~
- If A31p w/'NASA Video Monitor' under Station Apps:
 - √Drag-Thru Cable connected to A31p Video Adapter
 - √PWR – ON
 - Sel 'Station Apps: NASA Video Monitor'
 - √'NASA Video Monitor 1.0.0.0' window displayed
 - Sel 'Settings'
 - √'Configuration' window displayed
 - Video Input Standard: – NTSC
 - √Input – 'Composite (RCA)'
 - Control – press 'Set to defaults' pb
 - Commit Changes – 'OK'
 - Sel 'Full Screen'
 - Press 'ESC' to minimize display as reqd

PAO EVENT

1. Config VPU
 - R12 (VPU)
 - √Green Jumper – ISS
 - √VPU PWR – ON (LED on)
2. Config Shuttle Video
 - A7
 - VID OUT DNLK pb – push
 - IN PL2(VPU) pb – push

P/TV05 ISS INTERNAL OPS (Continued)

SETUP (Concluded)

STILL CAMR

1. Perform D2Xs PROGRAM w/FLASH

Lens – 12-24mm

√Aperture – Min, locked

Body Focus Mode – S

√Batt installed

√Flash Card installed

Pwr – ON

Top LCD:

√Batt

√Frames remaining sufficient

Exp Comp () – 0.0

Exp Mode – P

Meter – Matrix ()

Diopter – Adjust

Frame Rate – S

√BKT disabled – 0 F

Rear LCD:

√ISO – 100

√QUAL – RAW

√WB – 0,A

AF Area Mode – [[]]

√Focus Area – Center

√Focus Selector Lock – L

SB-800 Flash Settings:

√Diffuser Dome installed

ON/OFF pb – ON

√MODE –   

√Exp Comp – 0 EV

Tilt – 45° (Direct)

P/TV05 ISS INTERNAL OPS (Continued)

OPS

√	Item # Track #	Rqmts	Still Imagery	Video			Notes
				PLB	CC	Dnlk	
	1. 19A-11	General ISS IVA Activity <ul style="list-style-type: none"> • PAO Scenes of Interest • Crew Photo 	<u>D2Xs</u> 12-24mm For Crew Photo: Perform D2Xs CREW PHOTO (Cue Card, <u>D2Xs</u> <u>SETUP</u>)		<u>ISS G1</u>	LIVE (if avail)	Plan for end of day crew choice video
	2. 19A-20 19A-21 19A-22 19A-23 19A-26 19A-27	MPLM <ul style="list-style-type: none"> • Node 2 to MPLM Vestibule leak chk, outfitting • Hatch opening • Closeout mapping of interior after ingress, prior to egress • Photos of rack xfers including pre-install, final configs of: <ul style="list-style-type: none"> – MELFI FU #3 – 7 RSPs – 3 RSRs – Crew qtrs – WORF – Express 7 – MARES – 2 ZSRs – AEC 	<u>D2Xs</u> 12-24mm		<u>ISS G1</u>	LIVE (if avail)	

If OPS temporarily suspended, perform DEACTIVATION as reqd
 If OPS completed, go to DEACTIVATION

P/TV05 ISS INTERNAL OPS (Concluded)

DEACTIVATION

1. D2Xs
Pwr – OFF
2. Drag-Through QD Box
Disconnect:
RWS Cables (two) from orbiter side Video 1,2 ports. Stow cables on orbiter
BPSMU Cables from orbiter side BPSMU 1,2 and ODS CCU ports; stow cables on orbiter
Transfer Drag-Through QD Box and remaining attached cables to ISS
3. Temp Stowed BPSMU
Remove temp-stowed BPSMU from ODS location. Stow in MA16N
4. TV System
Go to DEACTIVATION (Cue Card, TV) as reqd

ODS

|

This Page Intentionally Blank

P/TV06 ROBOTICS OPERATIONS

H/W SUMMARY

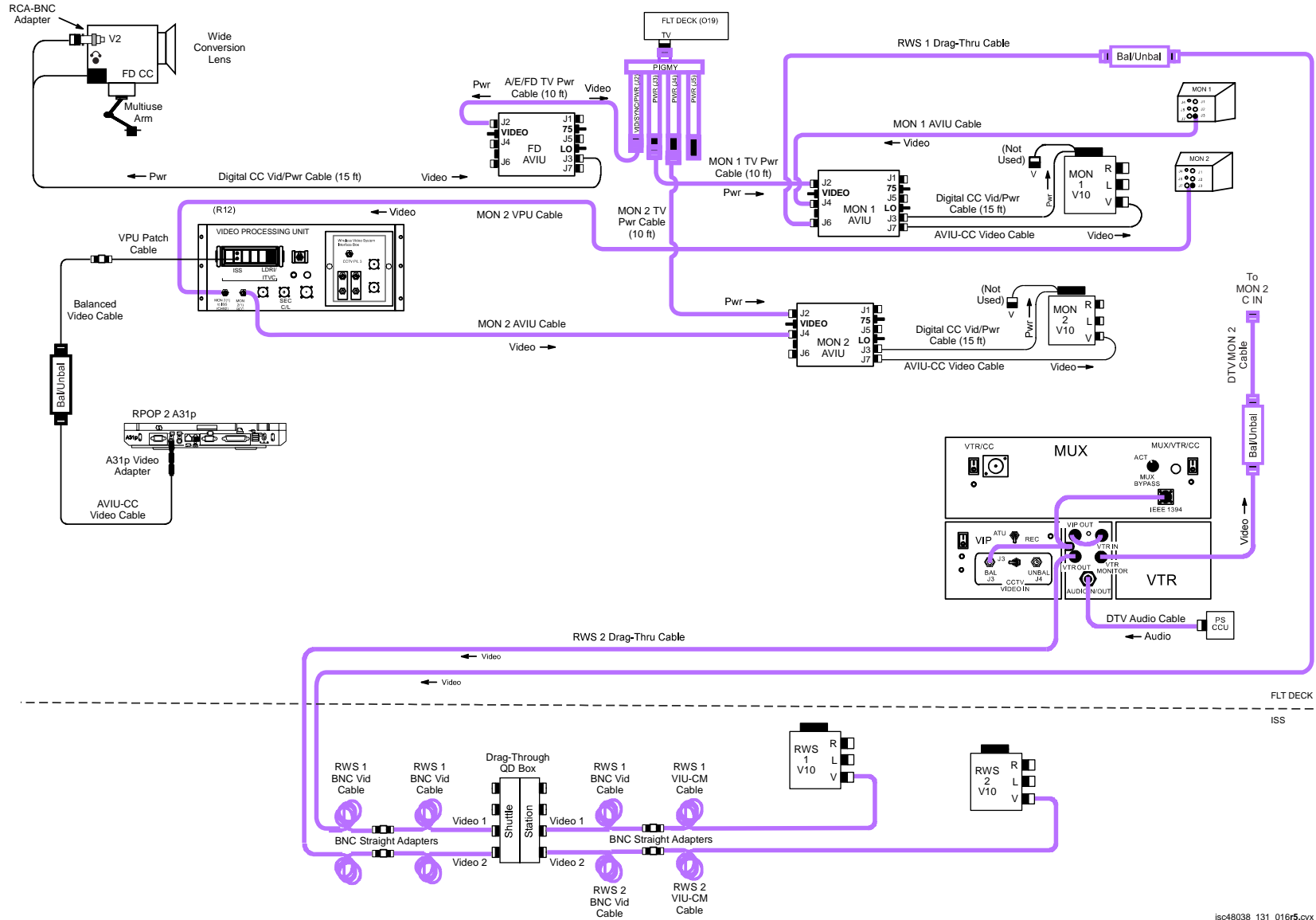

jsc48038_131_016r5.cvx

P/TV06 ROBOTICS OPERATIONS (Continued)

SCENE SYNOPSIS

Scene contains procedures for obtaining video of SSRMS activities

SETUP

1. Perform ACTIVATION, OPERATION (Cue Card, TV) as reqd
2. Perform Hardware Verification for V10s, FD CC, DTV, Keel Camr

O19	√TV PWR – ON
R12 (VPU)	√VPU PWR – ON (LED on) Green Jumper – LDRI/ITVC √Drag-Thru Cables configured as reqd
A17/DTV Bag	Unstow VPU Repeater Ziploc Bag, connect Cbl String between VPU “FROM ISS” to RPOP2 “VIDEO IN” per diagram on FS 1-48
V10 (MON 1,2)	PWR – ON √Tape installed DISPLAY pb – Toggle to display tape counter
CC	√Wide Conversion lens installed √ND FILTER – OFF √OUTPUT – CAM √ <input type="checkbox"/> ... <input type="checkbox"/> - <input type="checkbox"/> √STANDBY/LOCK – STANDBY PWR dial – “green” <input type="checkbox"/> √Tape installed √Viewfinder (LCD) displays “green” • Install Audio Muting Plug (optional) Install Multiuse Brkt
MON 1	SOURCE – DNLK
MON 2	SOURCE – C
L10 (MUX)	VTR/CC PWR – on (LED on) If dnk, MUX/VTR/CC PWR – on (LED on)
(VIP)	PWR – on (LED on)
(VTR)	ON/STANDBY LED – green √Tape installed

P/TV06 ROBOTICS OPERATIONS (Continued)

SETUP (Concluded)

- R12 (VPU) 3. MPLM Reberth:
 - √VPU PWR – ON
 - Green Jumper – KEEL 1
- (SSP 2)
 - √cb SW PWR 3 – cl
 - √MPLM KEEL CAM HTR/ILLUM PWR – ON
 - PWR – ON

OPS

√	Item # Track #	Rqmts	Still Imagery	Video			Notes
			DCS	PLB	CC	Dnlk	
	1. 19A-11	PAO Coverage	<u>D2Xs</u> 12-24mm If exterior: Flash ON/OFF – OFF	As desired	<u>G1</u> Tape installed	LIVE (if avail)	Plan for end of day crew choice video,DCS
	2. 19A-24	MPLM XFER TO ISS <ul style="list-style-type: none"> • SSRMS Grapple,Release • ROEU Disconnect • PRLA,Keel Latch Release • Unberth,Hover • Positioning Mnvr for CBM Seal Inspection • Premate Mnvr of MPLM to Node 2 • Matings • Capture • Securing MPLM to NODE 2 • SSRMS Release • Still Photo of RWS Monitor w/CBCS Overlay and CBCS Camr View of MPLM Target 	<u>D2Xs</u> 28-70mm EXP Mode – S SS: 1/30 sec Flash ON/OFF – ON	Per SODF: ROBO FS			Rcd video

P/TV06 ROBOTICS OPERATIONS (Concluded)

OPS (Concluded)

√	Item # Track #	Rqmts	Still Imagery	Video			Notes
			DCS	PLB	CC	Drnk	
	3. 19A-25	MPLM XFER to PLB <ul style="list-style-type: none"> • Removal • Berthing • PRLA Latching • ROEU Connect 		Per SODF: ROBO FS			Rcd video

I

If OPS temporarily suspended, perform DEACTIVATION as reqd
 If OPS completed, go to DEACTIVATION

DEACTIVATION

- L12 (SSP2) 1. TV System
 MPLM KEEL CAM PWR – OFF
 √HTR/ILLUM PWR – ON
- Go to DEACTIVATION (Cue Card, TV) as reqd

This Page Intentionally Blank

This Page Intentionally Blank

P/TV07 EVA

P/TV07 EVA

H/W SUMMARY

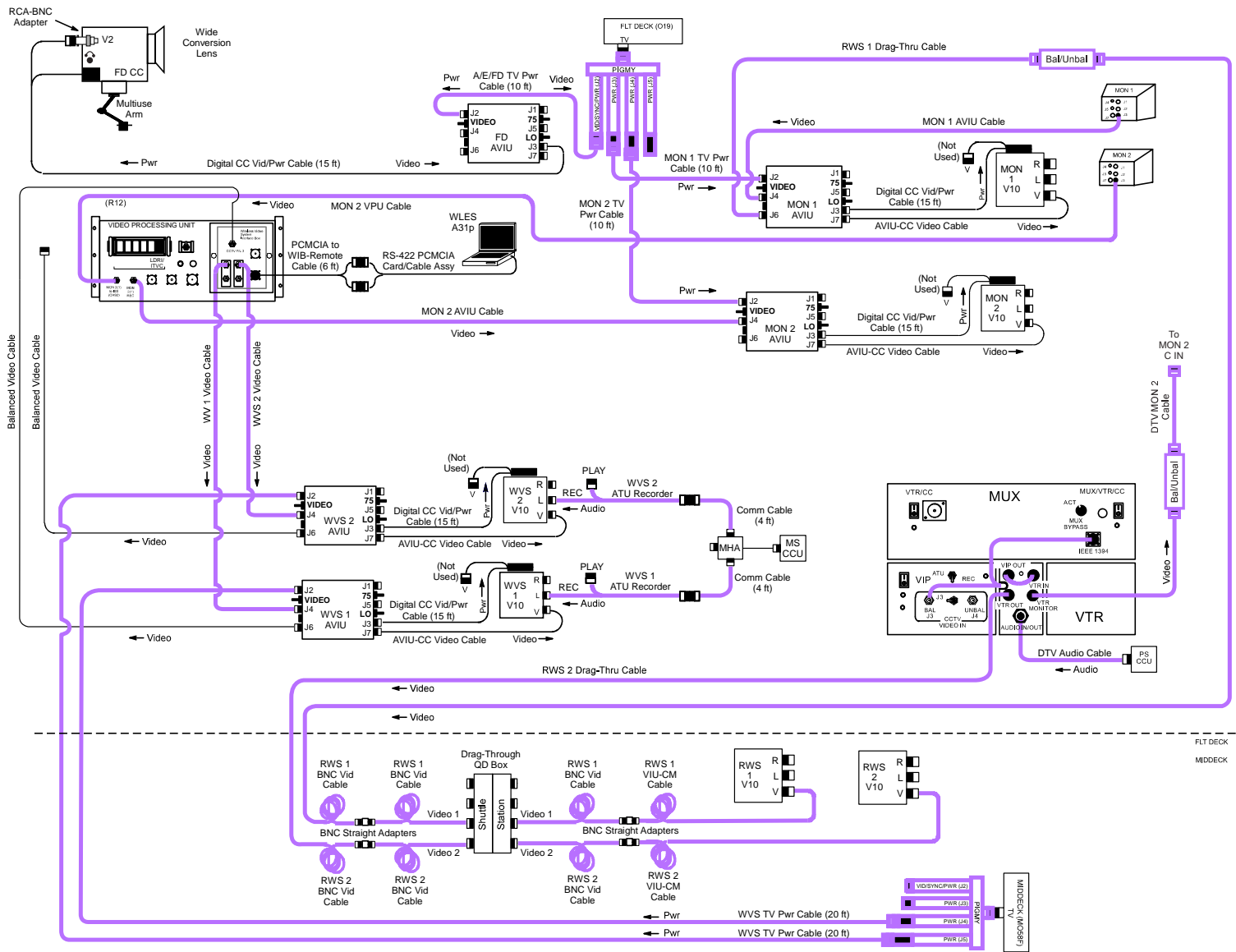

jsc48038_131_007R3.cvx

P/TV07 EVA (Continued)

SCENE SYNOPSIS

Scene contains procedures for documenting ISS EVA and IVA ops w/video,still photos

SETUP

FOR ALL EVAs:

1. Perform ACTIVATION,OPERATION (Cue Card, IV) as reqd

2. Perform D2Xs PROGRAM w/FLASH

Lens – 12-24mm

√Aperture – Min, locked

Body Focus Mode – S

√Batt installed

√Flash Card installed

Pwr – ON

Top LCD:

√Batt

√Frames remaining sufficient

Exp Comp () – 0.0

Exp Mode – P

Meter – Matrix ()

Diopter – Adjust

Frame Rate – S

√BKT disabled – 0 F

Rear LCD:

√ISO – 100

√QUAL – RAW

√WB – 0,A

AF Area Mode – [[]]

√Focus Area – Center

√Focus Selector Lock – L

SB-800 Flash Settings:

√Diffuser Dome installed

ON/OFF pb – ON

√MODE –  TTL  BL

√Exp Comp – 0 EV

Tilt – 45° (Direct)

P/TV07 EVA (Continued)

SETUP (Continued)

3. Perform Hardware Verification for V10s, FD CC, DTV

O19	√TV PWR – ON
R12 (VPU)	√VPU PWR – ON (LED on) √Green Jumper – LDRI/ITVC
V10 (MON 1,2, WVS 1,2)	PWR – ON √Tape installed DISPLAY pb – Toggle to display tape counter
CC	Install Wide Conversion lens √ND FILTER – OFF √OUTPUT – CAM √ <input type="checkbox"/> .. <input type="checkbox"/> - <input type="checkbox"/> √STANDBY/LOCK – STANDBY PWR dial – “green” <input type="checkbox"/> √Tape installed √Viewfinder (LCD) displays “green” • Install Audio Muting Plug (optional) Install Multiuse Brkt
MON 2 L10 (MUX) (VIP) (VTR)	SOURCE – C VTR/CC PWR – on (LED on) If dnlk, MUX/VTR/CC PWR – on (LED on) PWR – on (LED on) ON/STANDBY LED – green √Tape installed

P/TV07 EVA (Continued)

SETUP (Concluded)

4. Config WVS and PGSC

a. Activate WVS System

A7 √WIRELESS VID HTR – ON
 PWR – ON

b. WVS PGSC Prep

PGSC

PGSC Pwrup and Application Opening

Pwr – ON
Sel Shuttle Apps icon
Sel WVS icon
Sel 'No' at 'Restore To Previous Settings' window

If 'Comm Port Configuration' error displayed:
 Remove Quatech RS-422 Card
 Sel 'Start'> 'Shut Down'> 'Shut Down'> 'OK'
 Reinstall Quatech RS-422 Card
 Pwr – ON
 Sel Shuttle Apps icon
 Sel WVS icon
RF Camera page will appear

NOTE

During EVA prep, EMU TV assy will be pwr'd

Application Setup

Select Page – XCVR
Transceiver 1(2) CMD Power – ON (green CMD PWR:LVL- “ON:Min”)
RF Camera 1 – One EVA crewmember (green “ON”)
RF Camera 2 – Other EVA crewmember (green “ON”)

If alert msg, perform ALERT MSG TROUBLESHOOTING (Cue Card, WVS)

Select Page – RF CAMERA

Near middle of RF Camera page, sel 'Advanced Controls'

When Post-A/L Depress:

 For center lens on each RF Camr Assy:
 Lens Iris Cntl – op(cl) until good video on V10(MON)

P/TV07 EVA (Continued)

OPS

√	Item # Track #	Rqmts	Still Imagery	Video			Notes
				PLB	CC	Dnlk	
	1. 19A-11	PAO Coverage	IVA D2Xs 12-24mm If exterior: Flash ON/OFF – OFF	As desired <u>WVS</u>	G1 As desired	LIVE (if avail)	Plan for end of day crew choice video, DCS stills
	2. 19A-28	Thermal Cover Closeout Imagery <ul style="list-style-type: none"> All areas where thermal covers were altered during EVA 	<u>EVA D2Xs</u> per EVA C/L	<u>PLB Camrs</u> As desired <u>WVS</u>	G1 As available	LIVE (if avail)	
	3. 19A-13	LWAPA Retrieval Video <ul style="list-style-type: none"> Video of retrieval of LWAPA from Columbus EPF 		<u>PLB Camrs</u> As desired <u>WVS</u>		LIVE (if avail)	
	4. 19A-14	MPAC & SEED Retrieval from SEDA-AP <ul style="list-style-type: none"> Imagery of MPAC & SEED on SEDA-AP Still images of MPAC (rt hand side), then SEED (lt hand side), then of both prior to cover installation Video of retrieval task 	<u>EVA D2Xs</u> per EVA C/L	<u>PLB Camrs</u> As reqd <u>WVS</u>			

P/TV07 EVA (Concluded)

OPS (Concluded)

√	Item # Track #	Rqmts	Still Imagery	Video			Notes
				PLB	CC	Dnlk	
	5. 19A-15	<u>EVA Closeouts</u> a. S1 ATA (old), EVA 1 b. RGA 1 R&R c. ATA temp tiedown on CETA d. P1/P3 fluid jumper closeout e. S1 ATA (new), EVA 2 f. CETA brake handles & WIFs g. CLPA h. CP 13 ETVCG	<u>EVA D2Xs</u> per EVA C/L	<u>PLB Camrs</u> As desired <u>WVS</u>		LIVE (if avail)	

If OPS temporarily suspended, perform DEACTIVATION as reqd
 If OPS completed, go to DEACTIVATION

DEACTIVATION

1. IVA D2Xs
 Pwr – OFF
 √Flash ON/OFF – ON
 Download images
2. TV System
 Perform PWRDN (Cue Card, WVS)
 Go to DEACTIVATION (Cue Card, TV) as reqd

This Page Intentionally Blank

This Page Intentionally Blank

**P/TV08
EXT SURVEY**

P/TV08 EXTERNAL SURVEY

SCENE SYNOPSIS

Scene contains procedures for documenting STS,ISS external structures w/still photos during general survey activities

SETUP

1. D2Xs Camr Configuration for OMS Pod Survey

Remove aft window shields

If Sunlit OMS Pod, config D2Xs Manual Mode:

SB-800 Flash Settings:
ON/OFF pb – OFF

Lens – 80-200mm at 200mm

Focus Limit – full

Lens Focus Mode – A

Aperture – Min,locked

Body Focus Mode – S

√Batt installed

Install Empty Card

Pwr – ON

Top LCD:

√Batt

√Frames remaining sufficient

Exp Comp () – 0.0

Exp Mode – M:

SS – 1000

f/stop – F8

Meter – Matrix ()

Diopter – Adjust

Frame Rate – S

√BKT disabled – 0 F

Rear LCD:

√ISO – 100

√QUAL – RAW

√WB – 0,A

AF Area Mode – [[]]

√Focus Area – Center

√Focus Selector Lock – L

P/TV08 EXTERNAL SURVEY (Continued)

SETUP (Continued)

1. D2Xs Camr Configuration for OMS Pod Survey (Concluded)

↑
If Earthshine OMS Pod, config D2Xs Program Mode:

SB-800 Flash Settings:
ON/OFF pb – OFF

Lens – 80-200mm at 200mm

Focus Limit – full

Lens Focus Mode – A

√Aperture – Min, locked

Body Focus Mode – S

√Batt installed

Install Empty Card

Pwr – ON

Top LCD:

√Batt

√Frames remaining sufficient

Exp Comp () – 0.0

Exp Mode – P

Meter – Matrix )

Diopter – Adjust

Frame Rate – S

√BKT disabled – 0 F

Rear LCD:

√ISO – 100

√QUAL – RAW

√WB – 0,A

AF Area Mode – [[]]

√Focus Area – Center

√Focus Selector Lock – L

P/TV08 EXTERNAL SURVEY (Continued)

SETUP (Continued)

2. D2Xs Camr Config for ISS Still Survey (D2Xs Shutter Priority Mode)

SB-800 Flash Settings:
ON/OFF pb – OFF

Lens – 50mm(80-200mm @ 200mm)

If 80-200mm:

Focus Limit – full

Lens Focus Mode – A

√Aperture – Min, locked

Body Focus Mode – S

√Batt installed

√Flash Card installed

Pwr – ON

Top LCD:

√Batt

√Frames remaining sufficient

Exp Comp () – 0.0

Exp Mode – S:

SS – 500

Meter – Matrix ()

Diopter – Adjust

Frame Rate – S

√BKT disabled – 0 F

Rear LCD:

√ISO – 100

√QUAL – RAW

√WB – 0,A

AF Area Mode – [[]]

√Focus Area – Center

√Focus Selector Lock – L

P/TV08 EXTERNAL SURVEY (Continued)

SETUP (Continued)

3. SEITE(SIMPLEX) OMS Burn Photography
- 3a. Remove window shields prior to setup
- 3b. Perform ACTIVATION, OPERATION (Cue Card, TV) as reqd
- 3c. D2Xs Camr Config for SEITE(SIMPLEX) (D2Xs Shutter Priority Mode)

SB-800 Flash Settings:
ON/OFF pb – OFF

Lens – 28mm

√Aperture – Min, locked

Lens Focus Mode – M

√Batt installed

√Flash Card installed

Pwr – ON

Top LCD:

√Batt

√Frames remaining sufficient

Exp Comp () – 0.0

Exp Mode – S:

SS – 500

Meter – Matrix ()

Diopter – Adjust

Frame Rate – CL

√BKT disabled – 0 F

Rear LCD:

√ISO – 100

√QUAL – RAW

√WB – 0,A

AF Area Mode – [[]]

√Focus Area – Center

√Focus Selector Lock – L

P/TV08 EXTERNAL SURVEY (Continued)

SETUP (Concluded)

3c. D2Xs Camr Config for SEITE(SIMPLEX) (D2Xs Shutter Priority Mode) (Concluded)

Menu Settings:

MENU pb – press

Navigation Pad sel – Shooting Menu () Hi-speed Crop > ON

– Custom Settings Menu > d Shooting/Display > d1 Shooting Speed > 4 fps

Accessory Equipment:

Shutter Release Cable – install

Multiuse Base – install in W9/10

Multiuse Brkt – install on Base

Frame on OMS pod

3d. Perform Hardware Verification for DTV

L10 (MUX)

VTR/CC PWR – on (LED on)

(VIP)

√ATU – REC

√CCTV VIDEO IN – J3

PWR – on (LED on, DATA FLOW flashes twice)

(VTR)

√ON/STANDBY LED – green

√Switches set to white dot (seven)

√COUNTER SELECT – COUNTER (TC)

√Tape installed (tape icon LED on)

Set GMT:

DISPLAY SELECT – MENU

↓ pb – ETC, EXEC pb – push

↓ pb – CLOCK SET, EXEC pb – push

Use ↓, ↑, EXEC to set Y,M,D,hr,min to GMT

DISPLAY SELECT – DATA

L9

If Audio desired:

PS AUD PWR – AUD

Desired Loops – RCV, Vol tw 5

Other Loops – OFF

A7

VID OUT DTV pb – push

VID IN pb – A(D)

L10 (VTR)

REC pb – push, hold

PLAY pb – push, simo (red dot displayed)

P/TV08 EXTERNAL SURVEY (Continued)

OPS

√	Item # Track #	Rqmts	Still Imagery	Video			Notes
				PLB	CC	Dnlk	
	1.	<u>OMS Pod Survey</u> <ul style="list-style-type: none"> •√No shadows on OMS pod tiles • Remove window shields • 50 percent overlap mapping of both OMS pods and vertical stabilizer w/emphasis on Black Tile areas • Repeat thru other window 	<u>D2Xs</u> 80-200mm @ 200mm				Download images to MCC once complete 
	2. 19A-5	<u>ISS Still Survey</u> <ul style="list-style-type: none"> • Surfaces • Solar Panels • Handrails • MISSE-7 on ELC2 on S3 • SOLAR on Columbus EPF 	<u>D2Xs</u> 28-70mm @ 50mm (80-200mm @ 200mm)				Map ISS surfaces w/30% overlap from all Flt Deck windows
	3.	<u>SEITE(SIMPLEX)</u> <ul style="list-style-type: none"> • Initiate photo sequence 1 sec prior to burn • Start DTV VTR 5 min prior to burn 	<u>D2Xs</u> 28mm	<u>A(D)</u>		LIVE (if avail)	√Focus set on OMS pad

P/TV08 EXTERNAL SURVEY (Continued)

OPS (Continued)

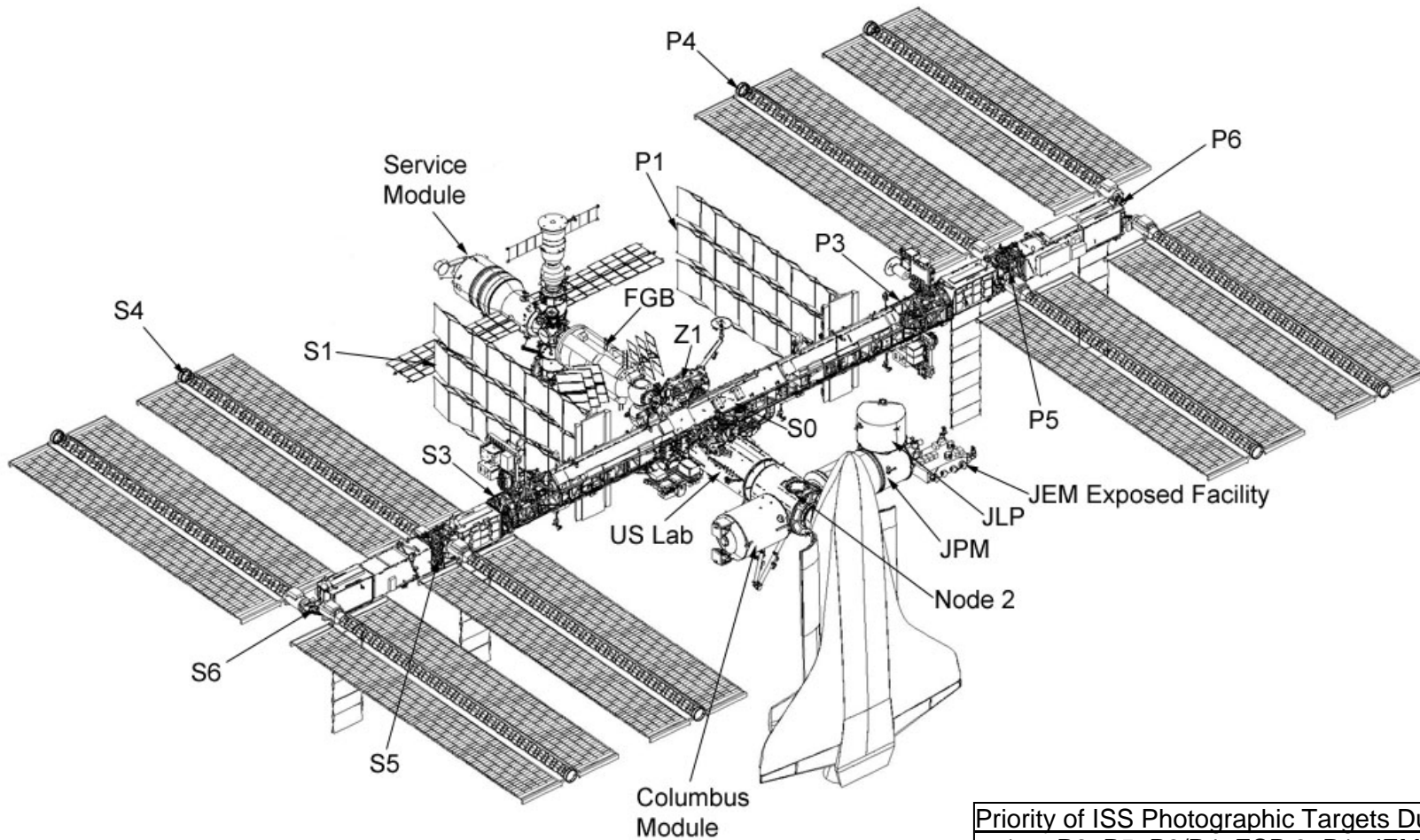

Priority of ISS Photographic Targets During Docked Phase:	
1.	P6, P5, P3/P4, ESP 3, P1, JEM, JLP, Columbus, S0, S1, S3/S4, S5, S6, Solar Arrays – W1, W6 (special emphasis on newly installed components)
2.	Node 2, Columbus, JEM, JLP – W7, W8
3.	PMA2 – W9, W10

P/TV08 EXTERNAL SURVEY (Concluded)

OPS (Concluded)

If OPS temporarily suspended, perform DEACTIVATION as reqd
If OPS completed, go to DEACTIVATION

DEACTIVATION

1. D2Xs

- √ Lens Focus Mode – A
- √ Exp Mode – P
- Frame Rate – S
- Flash ON/OFF – ON

Menu Settings:

MENU pb – press

Navigation Pad sel – Shooting Menu () Hi-speed Crop > OFF

– Custom Settings Menu > d Shooting/Display > d1 Shooting Speed > 3 fps

2. TV System

Remove, mark tape for SEITE(SIMPLEX)

Go to DEACTIVATION (Cue Card, TV) as reqd

This Page Intentionally Blank

This Page Intentionally Blank

**P/TV09
MIDDECK PL**

P/TV09 MIDDECK PAYLOADS

H/W SUMMARY

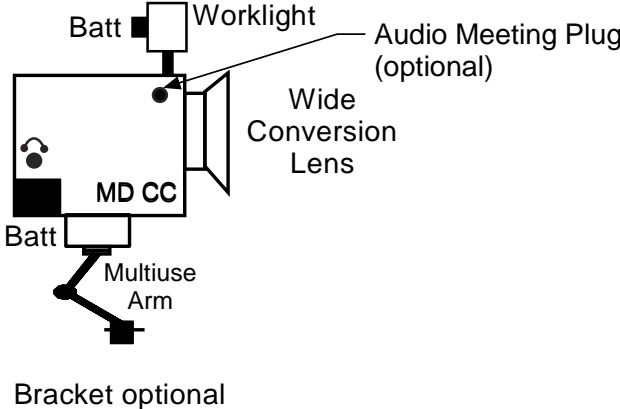

jsc48038_131_017r1.cvx

P/TV09 MIDDECK PAYLOADS (Continued)

SCENE SYNOPSIS

Scene contains procedures for obtaining in-cabin photo-documentation conducted within orbiter/ISS of GLACIER, MERLIN, MOUSE, STL |

SETUP

1. Perform Camcorder Setup for MD per H/W SUMMARY, FS 1-76, as reqd

CC

- √Batt installed
- Install Wide Conversion lens
- √ND FILTER – OFF
- √OUTPUT – CAM
- √..-
- √STANDBY/LOCK – STANDBY
- PWR dial – “green”
- √Tape installed
- √Viewfinder (LCD) displays “green” •||
- Install Audio Muting Plug (optional)
- Install Multiuse Brkt, Clamp as reqd

CAUTION

Due to temp constraints, worklights at full
pwr for 60 min; 90% pwr for unlimited time



Worklight

- Install fresh Batts
- Mount light on CC
- PWR – as reqd

P/TV09 MIDDECK PAYLOADS (Continued)

SETUP (Concluded)

2. Perform D2Xs PROGRAM w/FLASH

- Lens – 12-24mm
- Aperture – Min, locked
- Body Focus Mode – S
- √Batt installed
- √Flash Card installed
- Pwr – ON
- Top LCD
 - √Batt
 - √Frames remaining sufficient
- Exp Comp () – 0.0
- Exp Mode – P
- Meter – Matrix ()
- Diopter – Adjust
- Frame Rate – S
- √BKT disabled – 0 F
- Rear LCD
 - √ISO – 100
 - √QUAL – RAW
 - √WB – 0,A
- AF Area Mode – [[]]
- √Focus Area – Center
- √Focus Selector Lock – L

- SB-800 Flash Settings
 - √Diffuser Dome installed
 - ON/OFF pb – ON
 - √MODE –  TTL BL
 - √Exp Comp – 0 EV
 - Tilt – 45° (Direct)

P/TV09 MIDDECK PAYLOADS (Continued)

OPS

√	Item # Track #	Rqmts	Still Imagery	Video			Notes
			DCS	PLB	CC	Dnlk	
	1. 19A-7 19A-8	GLACIER Video, Still Photography <ul style="list-style-type: none"> • Wide-angle video, photos showing crew interaction • Medium-angle video, photos showing stowage location • Closeup video, photos of front panel after activation for gnd verification 	<u>D2Xs</u> 12-24mm		<u>G1</u>	LIVE desired within 12 hrs	
	2. 19A-31 19A-32	MERLIN Video, Still Photography <ul style="list-style-type: none"> • Wide-angle video, photos showing crew interaction • Medium-angle video, photos showing stowage location • Closeup video, photos of front panel after activation for gnd verification 	<u>D2Xs</u> 12-24mm		<u>G1</u>	PLAYBACK desired	
	3. 19A-33 19A-34	MOUSE Immunology <ul style="list-style-type: none"> • Record 10 min video of 1st, 2nd AEM • Take general photos of experiment, ops 	<u>D2Xs</u> 12-24mm		<u>G1</u>	Video is restricted. Do not DNLK (PLAYBACK)	Frame the view of the animal enclosure Label tape 'AEM Video' Do not clamp on metal tape Use Witches Hat as reqd
	4. 19A-9 19A-10	STL Still Photography <ul style="list-style-type: none"> • Photos of front panel, crew interaction • Take at completion of initialization and re-entry procedures 	<u>D2Xs</u> 12-24mm				

If OPS temporarily suspended, perform DEACTIVATION as reqd
 If OPS completed, go to DEACTIVATION

P/TV09 MIDDECK PAYLOADS (Concluded)

DEACTIVATION

- Worklight
CC
1. PWR – OFF
Remove, mark tape
PWR dial – OFF

This Page Intentionally Blank

P/TV10 EPO – ROBOTICS

H/W SUMMARY

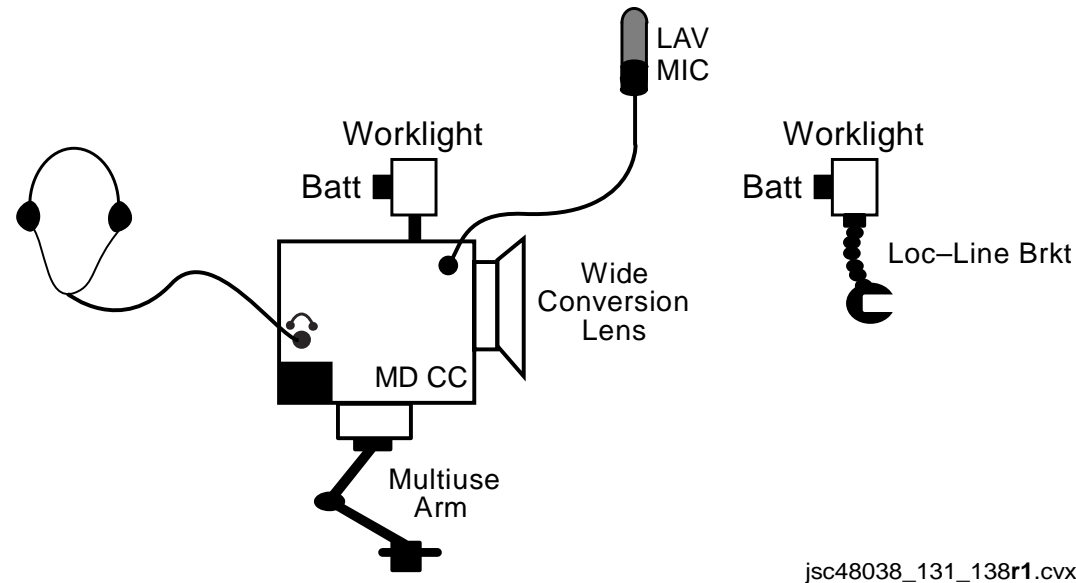

SCENE SYNOPSIS

Scene contains procedures for recording video for Education Payload Operations (EPO) of MS2 explaining importance of Robotic Operations and Exploration on Shuttle, ISS at their respective ARM OPS stations. Video intended for students 5-12

P/TV10 EPO – ROBOTICS (Continued)

SETUP

Config H/W per H/W SUMMARY on FS 1-76

- CC
- √Fresh Batt installed
 - √Wide Conversion lens installed
 - √ND FILTER – OFF
 - √AF/M – AF
 - GAIN – L(M) per scene exposure
 - √OUTPUT – CAM
 - √AWB – ON
 - √..-
 - √STANDBY/LOCK – STANDBY
 - PWR dial – A
 - Open LCD
 - √CP1(2-9) displayed
 - Install fresh tape
 - Mount CC w/Multiuse Brkt, Clamp as reqd
 - Install Headphones
 - Install LAV MIC
- LAV MIC
- ON/OFF – ON

CAUTION

Due to temp constraints, worklights at full pwr for 60 min; 90% pwr for unlimited time

- Worklight (2)
- Install fresh Batts
 - Mount First Light on CC
 - Mount Second Light w/Brkt (Velcro/Tape)
 - PWR – as reqd
- Cabin Lts
- On as reqd
 - Lts in FOV – OFF as reqd
 - Lt, Window Shades – install as reqd
- CC
- √Scene Composition, Lighting, adjust as reqd
 - √Audio Quality

P/TV10 EPO – ROBOTICS (Continued)

OPS

SCENE LOCATION	SCRIPT
Shuttle Robotic Arm Workstation	<p>Talking Points: (Note: Talking points do not need to be completed verbatim. Dottie is encouraged to use her own words if preferred.)</p> <p>Introduction: Objective: Provide students/educators w/background info on yourself (Dottie)/setting/purpose.</p> <p><i>(Dottie floats in front of the camera with the shuttle robotic arm workstation in the background)</i></p> <p>“Hello, my name is Dottie Metcalf-Lindenburger and I am a Mission Specialist with STS-131.</p> <p>Currently I am on Space Shuttle Discovery orbiting 240 miles above the Earth and traveling about 17,500 mph.</p> <p><i>(Dottie does a somersault or floats an object in front of her)</i></p> <p>As you can see...I am in microgravity.</p> <p>This is a unique environment that allows us to conduct many experiments that would be more difficult to conduct on Earth.</p> <p>The Space Shuttle Discovery is currently docked with the International Space Station.</p> <p>The ISS is filled with many biological and technological experiments that help us with Earth applications and long duration space flight.</p> <p>The research obtained helps us learn more about what it will take to go back to the moon, on to Mars, and beyond.”</p>

P/TV10 EPO – ROBOTICS (Continued)

OPS (Continued)

SCENE LOCATION	SCRIPT
Shuttle Robotic Arm Workstation (Continued)	<p>Topic 1 – Robotics Overview: Objective: Provide students/educators w/overview of general NASA robotics.</p> <p>“Exploring space is a difficult task. Scientists and engineers are working everyday to develop robotic explorers for many destinations that humans are not capable of traveling to at this time.</p> <p>Robotics is a topic that involves many different areas. Currently robotics is being used in spacecrafts like LRO, LCROSS, CASSINI, and Hubble that capture data about distant planets and moons. Robotic rovers and landers such as Spirit, Opportunity, and Phoenix are investigating Mars. Robotic aircraft such as Global Hawk are being developed to investigate environmental science research. Human interactive robotics like Robonaut are being developed. And robotic arms assist us with many difficult tasks here on the space shuttle and ISS.”</p> <p>Topic 2 – Shuttle Robotic Arm: Objective: Provide students/educators w/overview of the Shuttle Robotic Arm and procedures from the workstation.</p> <p>“I am standing in front of the shuttle robotic arm workstation. This workstation involves the controls needed to manipulate the robotic arm that is located in the payload bay of the shuttle. This arm was developed by Canada. We call it the Space Shuttle Robotic Manipulator System or simply, the shuttle arm.</p> <p><i>(Dottie uses her arm to demonstrate the joints)</i> The robotic arm is similar to a human arm. It has two joints in the shoulder, 1 joint in the elbow, and 3 joints in the wrist.</p> <p>The joints may be similar, however the length and weight are very different. The robotic arm is about 50 feet in length and weighs about 900 pounds on Earth.</p> <p>I thought I was pretty strong, but the robotic arm is much stronger. It has a mass handling capacity of about 200,000 pounds. Wow! That is a lot!</p>

P/TV10 EPO – ROBOTICS (Continued)

OPS (Continued)

SCENE LOCATION	SCRIPT
<p>Shuttle Robotic Arm Workstation (Concluded)</p>	<p>The robotic arm may be longer and stronger than my arm, but my arm is much quicker. The robotic arm is only capable of moving about 2 inches every second when it is loaded. This is because in space it is very difficult to start or stop large masses in motion. Newton’s Laws can help explain why. We also do not want to damage any components by moving them too quickly.</p> <p>The shuttle robotic arm is used on every flight to check for damage to the tiles that protect the shuttle during re-entry to Earth’s atmosphere. The shuttle robotic arm can also be used to take payloads out of the payload bay and attach them to the space station, but we will not be doing that with the shuttle arm on this flight.</p> <p>A lot of the maneuvers we make are difficult to see from the windows. To assist us we have 2 video cameras installed, one on the elbow and one on the wrist of the robotic arm.</p> <p>There are also several other cameras that are attached to the shuttle payload bay that we can use. And when we’re docked to the ISS, we can use their cameras also.</p> <p><i>(Dottie discusses some of the controls that are used to manipulate the arm and some of the robotic arm tasks that she is conducting during her mission)</i></p> <p>Now, let’s head over to the International Space Station and check out the robotic work station there.”</p> <p><i>(Dottie floats away from camera view)</i></p>

P/TV10 EPO – ROBOTICS (Continued)

OPS (Continued)

SCENE LOCATION	SCRIPT
Station Robotic Arm Workstation	<p>Topic 3 – Station Robotic Arm: Objective: Provide students/educators w/overview of the Station Robotic Arm and procedures from the workstation.</p> <p>“Now I am standing in front of the ISS Mobile Servicing System for the station arm. This robotic arm is similar to the shuttle’s, but is much more versatile. The shuttle arm is fixed to the shuttle by one end. The station arm has no fixed end and can travel the entire length of the space station on the Mobile Base System.</p> <p>This robotic arm has many neat features such as force moment sensors to provide a sense of touch, automatic vision feature for capturing, and automatic collision avoidance. There are also four color video cameras, one on each side of the elbow and two on the Latching End Effectors.</p> <p>As you notice, there are no windows at the workstation. So we need to use the video cameras located on the arm and station along with the monitors to view what we are doing.”</p> <p>Topic 4 – Robotic Training and Careers: Objective: Provide students/educators w/background information on robotic arm training and careers involved.</p> <p>“These operations involve much training and practice. On the ground I trained for numerous hours on how to complete the tasks given during this mission. Many careers are involved with the robotic arm from the engineers who designed and constructed the arm; the engineers who train the astronauts on how to work the arm, to the astronauts that need to manipulate the arm on-orbit.</p> <p>The shuttle robotic arm cannot even support its own weight on earth, even though it’s capable of lifting several thousands of pounds of weight in microgravity. To learn how to use the shuttle robotic arm, we train in facilities that use computer-generated graphics that make it look like we’re flying the robotic arm, but it’s actually a simulator that is like a video game. All of the workstation displays and hand controllers are very much like the real workstations on the vehicles.</p>

P/TV10 EPO – ROBOTICS (Concluded)

OPS (Concluded)

SCENE LOCATION	SCRIPT
Station Robotic Arm Workstation (Concluded)	<p>The field of robotics includes a wide variety of careers. Many types of engineers and scientists are designing new types of robots that will explore and discover our future. Check out the Career Corner on the NASA Robotics website to learn more.”</p> <p>Closing: Objective: Inspire students to study science, technology, engineering, and math.</p> <p>“Robotics is a very cool topic and applies to many areas of content that students are learning in school including science, technology, engineering, and math. As I was learning this content or teaching it, I never thought I would be applying it someday in space. I hope you follow your dreams and maybe someday I will see you at NASA.</p> <p>To learn more about robotics check out the variety of resources available at the NASA Robotics website.</p> <p>Goodbye!” <i>(Dottie waves goodbye.)</i></p>

DEACTIVATION

Worklight (2) PWR – OFF
 CC Remove, protect, mark Tape
 PWR dial – OFF

LAV MIC ON/OFF – OFF

REFERENCED PROCEDURES

	<u>PAGE</u>
<u>CENTERLINE (C/L) CAMR</u>	
C/L CAMR INSTALL	FS 2-4
<u>DTV</u>	
VTR CLOCK SET	FS 2-8
<u>D2Xs</u>	
DATE/TIME SET	FS 2-10
<u>CANON G1</u>	
ANALOG (SD DTV) CC REC,DNLK	FS 2-12
HD CC DNLK	FS 2-14
<u>FCS CHECKOUT CAMR SETUP</u>	
SETUP	FS 2-18
DEACTIVATION	FS 2-19
<u>MINI-CAM</u>	
ENTRY VIDEO SETUP	FS 2-22
<u>LASER CAMR SYSTEM (LCS)/INTEGRATED SENSOR INSPECTION SYSTEM DIGITAL CAMR (IDC)</u>	
LCS/IDC (HEATER ONLY MODE)/(OPERATIONAL PWR MODE) DATA AND PWR INTERFACES	FS 2-26
PTU 2/MAIN BUS B SYSTEM DETAILS	FS 2-27
<u>D3s</u>	
SPECIFICATIONS	FS 2-30
LENS DATA	FS 2-31
NOMENCLATURE	FS 2-33
NOMINAL SETUP	FS 2-40
DATE/TIME SET	FS 2-43
DELETING SINGLE IMAGES	FS 2-43
ADDING .WAV FILES TO AN IMAGE	FS 2-43
DELETING .WAV FILE FROM AN IMAGE	FS 2-44
.WAV FILE PLAYBACK	FS 2-44

This Page Intentionally Blank

This Page Intentionally Blank

C/L CAMR

CENTERLINE (C/L) CAMR

C/L CAMR INSTALL

1. ODS C/L Camr Config
- L12 (SSP 2) ✓C/L CAM PWR – OFF
- R12 (VPU) ✓SEC C/L Cap installed
 ✓Green Jumper – SEC C/L
 ✓VPU PWR – ON (LED on)
- ML60B Unstow PRI C/L Camr, PRI C/L TV Camr Harness Assy

NOTE

When connecting ODS C/L TV Camr Harness Assy, ✓pins to socket connection

- ODS ✓ODS C/L Camr Brkt mounted securely
 Mount PRI C/L Camr to ODS C/L Camr Brkt
 ✓Flex Duct attached to Camr brkt
 Config cable per dwg at right
- C/L Camr ✓SSF/STS sw – STS
- L12 (SSP 1) ✓cb SSP2 SEC C/L CAM – cl
 (SSP 2) C/L CAM PWR – SEC ON
- A6L LT VEST PORT,STBD – ON as reqd
- Perform ACTIVATION (Cue Card, TV) as reqd
- A7 VID OUT MON 1(2) pb – push
 IN PL2(VPU) pb – push
 ALC pb – push
 AVG pb – push

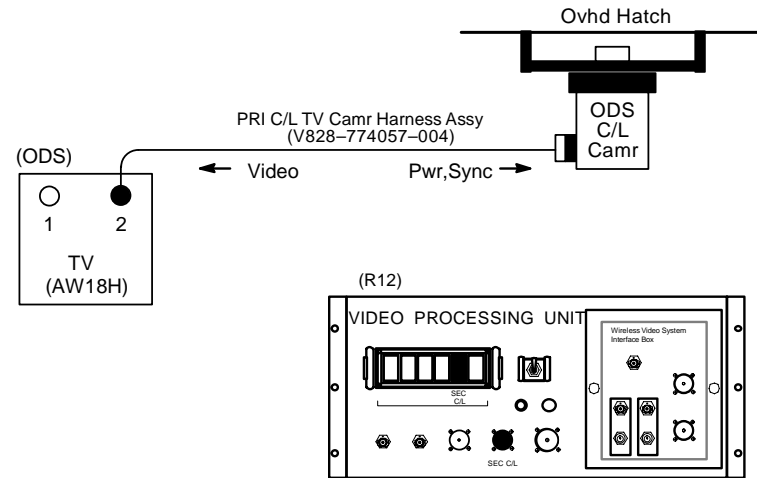

jsc48037_048r2.cvx

CENTERLINE (C/L) CAMR (Continued)

C/L CAMR INSTALL (Continued)

2. Camr Position Verification

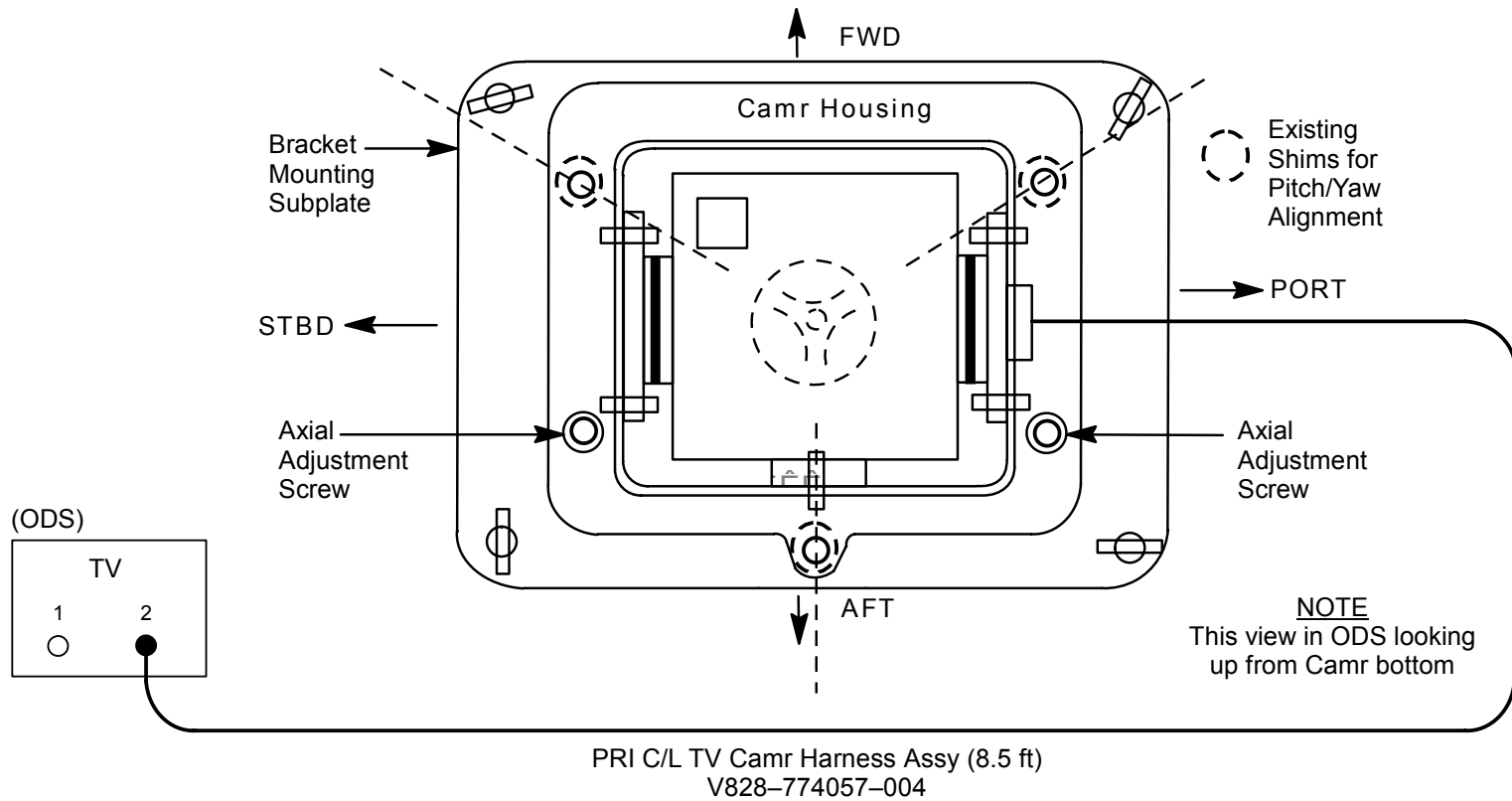

jsc48037_049r2.cvx

CENTERLINE (C/L) CAMR (Concluded)

C/L CAMR INSTALL (Concluded)

MON 1(2) 3. ODS C/L Camr Alignment Check
LDATA – ON
CDATA – GRN
XHAIR – GRN

A7 Zoom to $10^\circ \pm 0.5^\circ$
Focus to see Xhair target

NOTE

Green xhairs on monitor may move off center in calibration target when zooming in,out. Xhair will be closest to center at full zoom in position

MON 1(2) ✓ Vertical xhairs coincide w/vertical alignment wire and are parallel.
If xhair marks overlay each other, no yaw(axial) alignment needed (see dwg above)

✓ Intersection of monitor vertical, horizontal xhair falls within target circular opening from $\sim 10\text{-}40^\circ$ zoom range of Camr

Report results of both alignment verifications (at 10° and 40°) to MCC

A7 4. Deactivation
L12 (SSP 2) CAMR CMD IRIS – CL
C/L CAM PWR – OFF
Go to DEACTIVATION (Cue Card, TV) as reqd

A6L LT VEST PORT,STBD – OFF as reqd

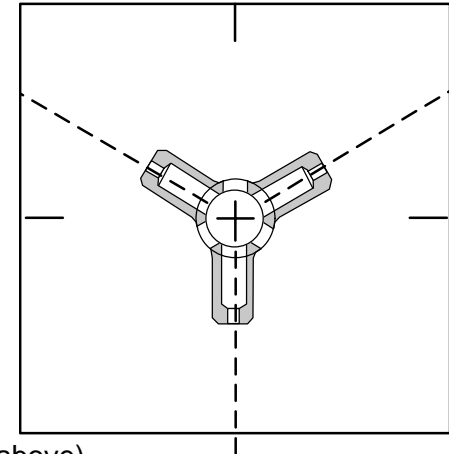

This Page Intentionally Blank

DTV

DTV

VTR CLOCK SET

1. Activate VTR

R1 √PL AUX – ON

L10 (MUX) VTR/CC PWR – on (LED on)
(VTR) √ON/STANDBY LED – green

2. Set VTR clock to GMT

DISPLAY SELECT – MENU

↓ pb – ETC, EXEC pb – push

↓ pb – CLOCK SET, EXEC pb – push

Use ↑,↓,EXEC to set Y,M,D,hr,min to GMT

DISPLAY SELECT – DATA

3. Deactivate VTR,VIP as reqd

(VIP) ON/STANDBY pb – push (red LED on)
 PWR – off (LED off)

This Page Intentionally Blank

D2Xs

D2Xs

DATE/TIME SET

1. MENU pb – press
2. Navigate pad – sel Menu icon **Y** setup menu
 - press (right)
 - sel WORLD TIME (up,down)
 - press (right)
 - sel DATE (up,down)
 - press (right)
3. Set TIME/DATE to GMT
 - Navigate pad – sel desired field (left,right)
 - sel desired setting (up,down)
4. ENTER pb – press
5. MENU pb – press twice

This Page Intentionally Blank

CANON G1

ANALOG (SD DTV) CC REC.DNLK

Config H/W per dwg at right

AVIU SYNC/VIDEO – VIDEO
 HI-Z/75 – 75
 PWR SELECT – LO

O19(MO58F) √TV PWR – ON

CC √Wide Conversion lens installed
 √ND FILTER – OFF
 Install Audio Muting Plug (optional)
 √OUTPUT – CAM
 √A/V1/V2 – V2
 √ [] .. [] - []
 √STANDBY/LOCK – STANDBY
 PWR dial – “green” []
 If rec to tape:
 Tape – Install
 √Viewfinder (LCD) displays “green” •||
 Mount w/Multiuse Brkt, Clamp as reqd

CAUTION
 Due to temp constraints, worklights at full pwr for 60 min; 90% pwr for unlimited time

Worklights Install fresh Batts
 Mount light(s) w/brkts (Velcro/tape)
 PWR – as reqd

Cabin Lts Flt Deck – ON
 Lts in FOV – OFF as reqd
 Lt Shades – install as reqd
 Window Shades – install as reqd

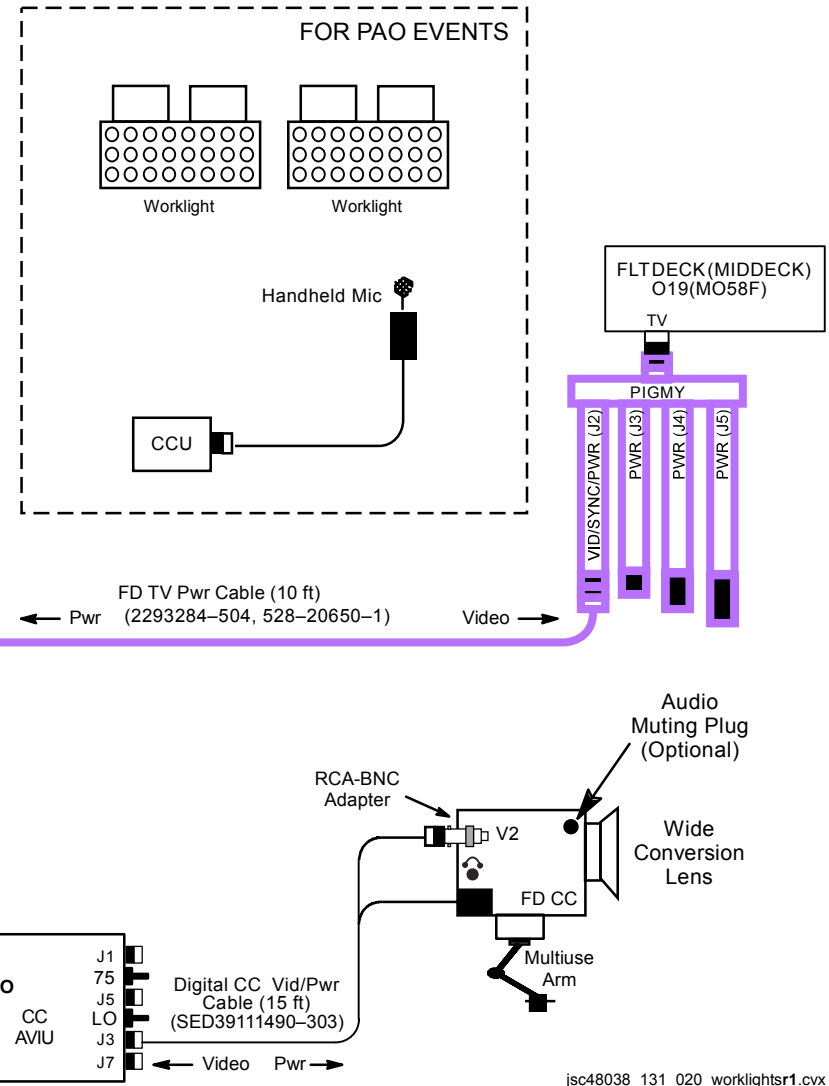

CANON G1 (Continued)

ANALOG (SD DTV) CC REC.DNLK (Concluded)

CC √Scene composition
 Adjust Camr angle for best framing

CCU CCU PWR – ON

ATU PWR – AUD
 A/G 1(2) – T/R
 All Other Loops – OFF
 XMIT/ICOM MODE SEL – PTT/PTT
 MSTR SPKR VOL SEL – as reqd

A7 When ready for dnlk:
 √TV DNLK – ENA
 PWR CNTL – PNL
 CONTR UNIT – MNA(B)
 CNTL – CMD (wait 10 sec for system initialization)

 If Analog, on MCC GO:
 | VID OUT DNLK pb – push
 | IN FLT DECK(MIDDECK) pb – push
 If SD DTV, on MCC GO:

L10 √Cables connected
(MUX) MUX/VTR/CC PWR – on (LED on)
 √MUX BYPASS – ACT
(VIP) PWR – on (LED on, DATA FLOW LED flashes twice)
(VTR) √ON/STANDBY LED – green
 √INPUT SELECT – VIDEO

A7 VID OUT DTV pb – push
 IN FLT DECK(MIDDECK) pb – push

L10 (MUX) √CH 3 DATA LED – on

 When dnlk complete:
CC PWR dial – OFF
Worklights PWR – off
L10 (MUX) MUX/VTR/CC PWR – off (LED off)

 Go to DEACTIVATION (Cue Card, TV) as reqd

CANON G1 (Continued)

HD CC DNLK



Notify MCC, configuring for HD TV dnlk

Config H/W per dwg at right

CC For cable strain relief attach MPC-to-G1 Cable Velcro strap to CC strap

AVIU SYNC/VIDEO – VIDEO
 HI-Z/75 – 75
 PWR SELECT – LO

O19 √TV PWR – ON

CC √Wide Conversion Lens installed
 Install LAV MIC
 √ND FILTER – OFF
 √OUTPUT – CAM
 √ - 
 √STANDBY/LOCK – STANDBY
 PWR dial – “green” 
 If rec to tape:
 TAPE – INSTALL
 √VIEWFINDER (LED) displays “green” •||
 Mount w/Multiuse Brkt, Clamp as reqd

L10 (MUX) √MUX/VTR/CC PWR – on (LED on)
 √MUX BYPASS – ACT
 √CH 0,1 RATE SEL – 1
 √2 RATE SEL – 8

(VTR) ON/STBY pb – push (LED red)
 (VIP) PWR – off (LED off)

O19 DC UTIL PWR MNA – ON
 MPC PWR DC PWR SPLY PWR SW1 – ON

MPC PWR SPLY PWR SW1 – ON
 MPC PWR – ON (HDV, TAXI, 5V, 3V green LEDs on)

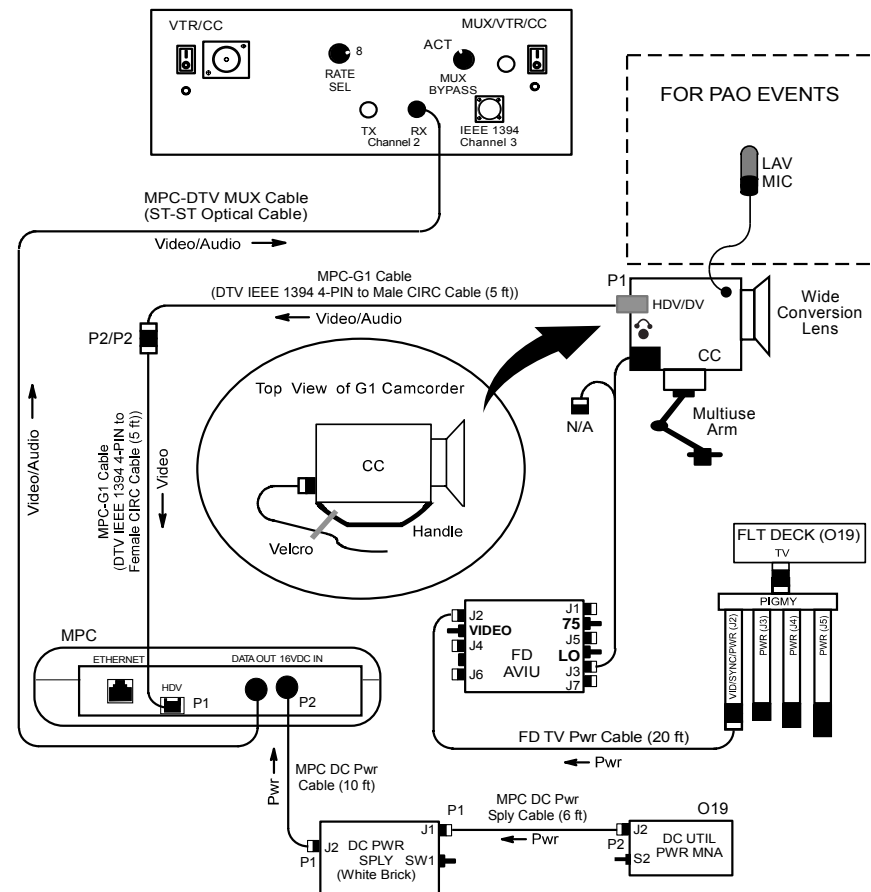
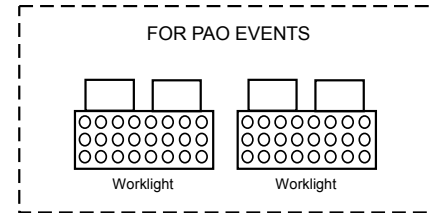

jsc48038_131_021_worklightsr1.cvx

CANON G1 (Continued)

HD CC DNLK (Continued)

L10 (MUX) ✓CH 2 F/O OK, DATA LEDs on

CAUTION

Due to temp constraints, worklights at full
pwr for 60 min; 90% pwr for unlimited time

Worklights Install fresh Batts
Mount light(s) w/brkts (Velcro/tape)
PWR – as reqd

Cabin Lts Flt Deck – ON
Lts in FOV – OFF as reqd
Lt Shades – install as reqd
Window Shades – install as reqd

CC ✓Scene composition

Adjust Camr angle for best framing

LAV MIC PWR – ON (talk), OFF (listen)

✓MCC if Black video and color bars reqd
If reqd:
 PWR dial – Av
 Aperture – close
 ✓Av CLOSE displayed on top left of LCD
 AGC – OFF
 ✓GAIN sw – L
 ✓±0dB displayed on LCD
 OUTPUT – BARS

When MCC says done w/bars:
 OUTPUT – CAM

When MCC says done w/black screen test:
 PWR dial – “green”

CANON G1 (Concluded)

HD CC DNLK (Concluded)

CC	When dnlk complete: PWR dial – OFF
Worklights	PWR – OFF
O19	TV PWR – OFF as reqd
MPC	PWR – OFF
PWR SPLY	DC PWR SPLY PWR SW1 – OFF
O19	DC UTIL PWR MNA – OFF
L10 (MUX)	MUX/VTR/CC PWR – off (LED off)
(VIP)	PWR – on (LED on, DATA FLOW LED flashes twice)
(VTR)	ON/STANDBY pb – push (LED green)

Notify MCC, returned to SD DTV dnlk

Go to DEACTIVATION (Cue Card, TV) as reqd

This Page Intentionally Blank

FCS CHECKOUT CAMR SETUP

SYNOPSIS

The following camera and camcorder settings will be used to photodocument items that may be liberated from the Orbiter during FCS C/O. Images and video should be downlinked if time and assets are available

SETUP

1. D2Xs

Lens – 400mm

NOTE

If auto focus unachievable:
Lens Focus Mode – M

SB-800 Flash Settings:
ON/OFF pb – OFF

Aperture – Min, locked
Lens Focus Limit – ∞ -6m
Lens Focus Mode – A
Body Focus Mode – S

√Batt installed

√Flash Card installed

Pwr – ON

Top LCD:

√Batt

√Frames remaining sufficient

Exp Comp – 0.0

Exp Mode – M:

SS – 500

f/stop – f/8

Meter – Matrix

Diopter – Adjust

Frame Rate – S

√BKT disabled – 0 F

Rear LCD:

√ISO – 100

√QUAL – RAW

√WB – 0,A

AF Area Mode – [[]]

√Focus Area – Center

√Focus Selector Lock – L

FCS CHECKOUT CAMR SETUP (Concluded)

SETUP (Concluded)

2. G1 CC

Remove Wide Conversion Lens

Install Batt

√ND FILTER – OFF

AF/M – M

AGC – OFF

GAIN – L

√OUTPUT – CAM

√AWB – ON

√..-

√STANDBY/LOCK – STANDBY

PWR dial – M

√Tape installed

Open LCD:

√'green' •|| displayed

SS – 1/500

√GAIN – 0dB

f/stop – F8.0

√FOCUS – M ∞

DEACTIVATION

1. D2Xs

Lens focus mode – A

EXP Mode – P

Pwr – OFF

2. G1

Install Wide Conversion Lens

AF/M – AF

AGC – ON

Pwr dial – OFF

Remove Batt

Connect Dig/CC Vid Pwr Cable

PWR dial – 'green'

Place G1 on brkt

This Page Intentionally Blank

This Page Intentionally Blank

FS 2-21

P/TV/131/FIN

MINI-CAM

MINI-CAM

MINI-CAM

ENTRY VIDEO SETUP

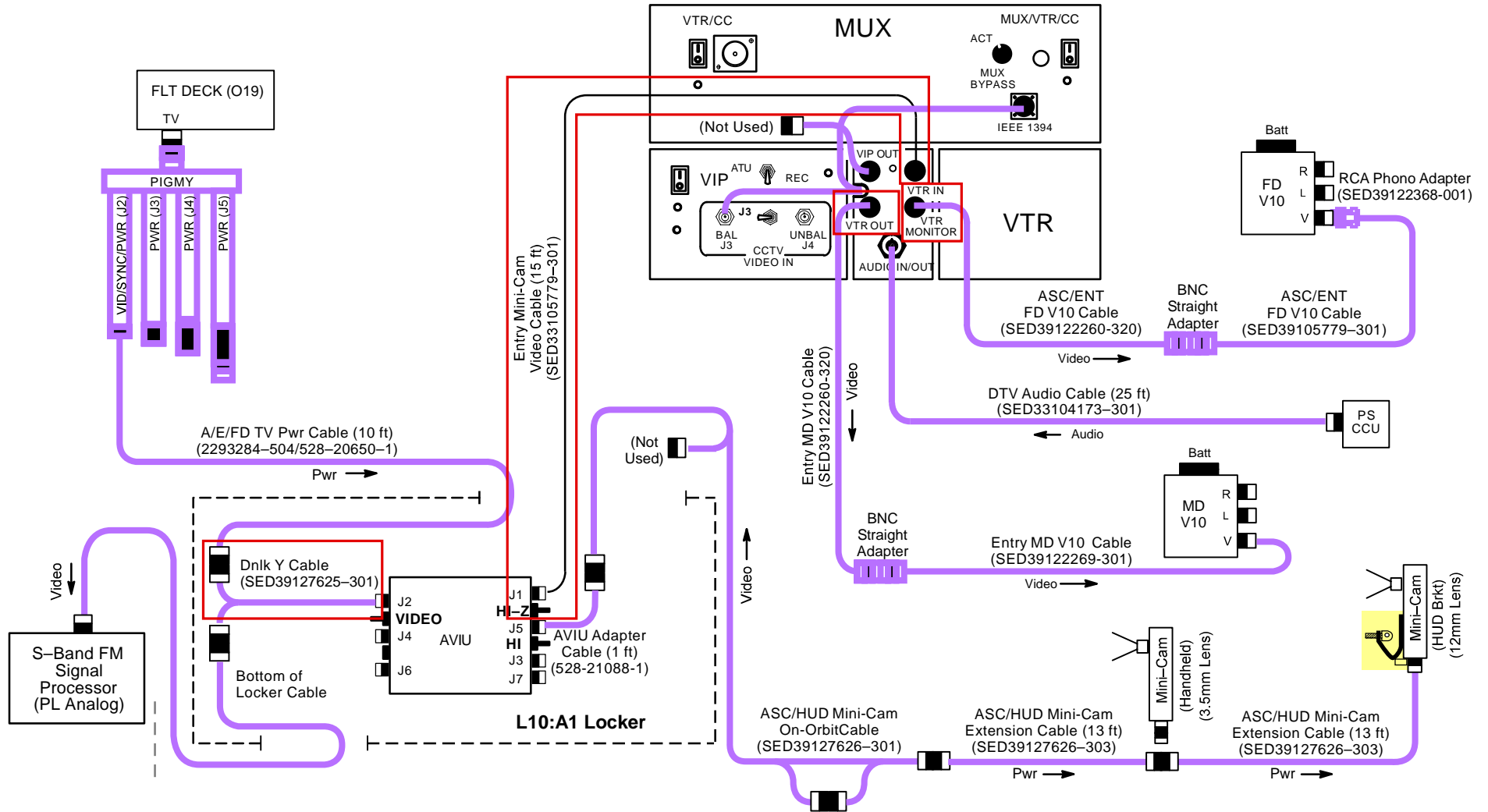

jsc48038_131_008r4.cvx

MINI-CAM (Continued)

ENTRY VIDEO SETUP (Continued)

1. Remove "Entry" Ziplock bag from DTV Bag
2. Config Mini-Cam, VTR for Audio, Video Recording
Config H/W per dwg, FS 2-22
 - a. Config HUD Mini-Cam w/12mm Lens
Using two (2) captive screws, attach HUD Brkt to installation holes for protective cover w/ HUD Brkt tab pointing up
Attach Tie Wrap thru holes on captive screws to prevent screw from coming loose; cut off extra length on Tie Wrap
Attach Mini-Cam Extension Cable to Mini-Cam

12mm Lens Focus – ∞ (Just off hard-stop)
Aperture – f/5.6 for daylight landing, 1.4 for night landing

Velcro Mini-Cam w/12mm Lens to HUD Brkt. (Top of black Velcro on front of Camr should be at top edge of HUD Brkt.
Only yellow Velcro should be visible above HUD Brkt)
 - b. Config in-cabin and MD Mini-Cam w/3.5mm Lens

3.5mm Lens Aperture – f/1.8
 - c. Config additional Mini-Cam H/W

L10:A1 AVIU
 SYNC/VIDEO – VIDEO
 HI-Z/75 – HI-Z
 PWR SELECT – HI

O19 \sqrt TV PWR – ON

PS ATU Config audio as reqd for entry audio

L10 (MUX)
 (VTR) VTR/CC PWR – on (LED on)
 \sqrt ON/STANDBY LED – green

MINI-CAM (Concluded)

ENTRY VIDEO SETUP (Concluded)

Acquire four (4) V10 Li-ION batts

NOTE

One Batt will be used on V10 for system c/o. Second Batt is spare. Batts will be removed after c/o and used for Entry

V10 (FD,MD) Install fresh Batt
PWR – ON
√HUD 12mm Lens/Mini-Cam producing good video

Change config to in-cabin 3.5mm Lens/Mini-Cam
√In-cabin 3.5mm Lens/Mini-Cam producing good video
√MD Camera view

PWR – OFF

L10 (VTR)
(MUX) ON/STANDBY pb – push (red LED off)
VTR/CC PWR – off (LED off)

O19 TV PWR – OFF

NOTE

TV, VTR pwr will be re-enabled per ENT AFT FLT DECK
CONFIG 15 (DEORB, NOMINAL DEORBIT PREP); recording
will be initiated via ENTRY C/L

Start w/3.5mm Lens/Mini-Cam video in-cabin and reconfig for 12mm Lens/Mini-Cam when exterior scene available

When exterior avail:

Focus – Adjust per V10

Aperture – Adjust per V10

If needed, turn down brightness on HUD display

Turn off V10 when not needed

This Page Intentionally Blank

LCS/IDC

LASER CAMR SYSTEM (LCS)/INTEGRATED SENSOR INSPECTION SYSTEM DIGITAL CAMR (IDC)

LCS/IDC (HEATER ONLY MODE)/(OPERATIONAL PWR MODE) DATA AND PWR INTERFACES

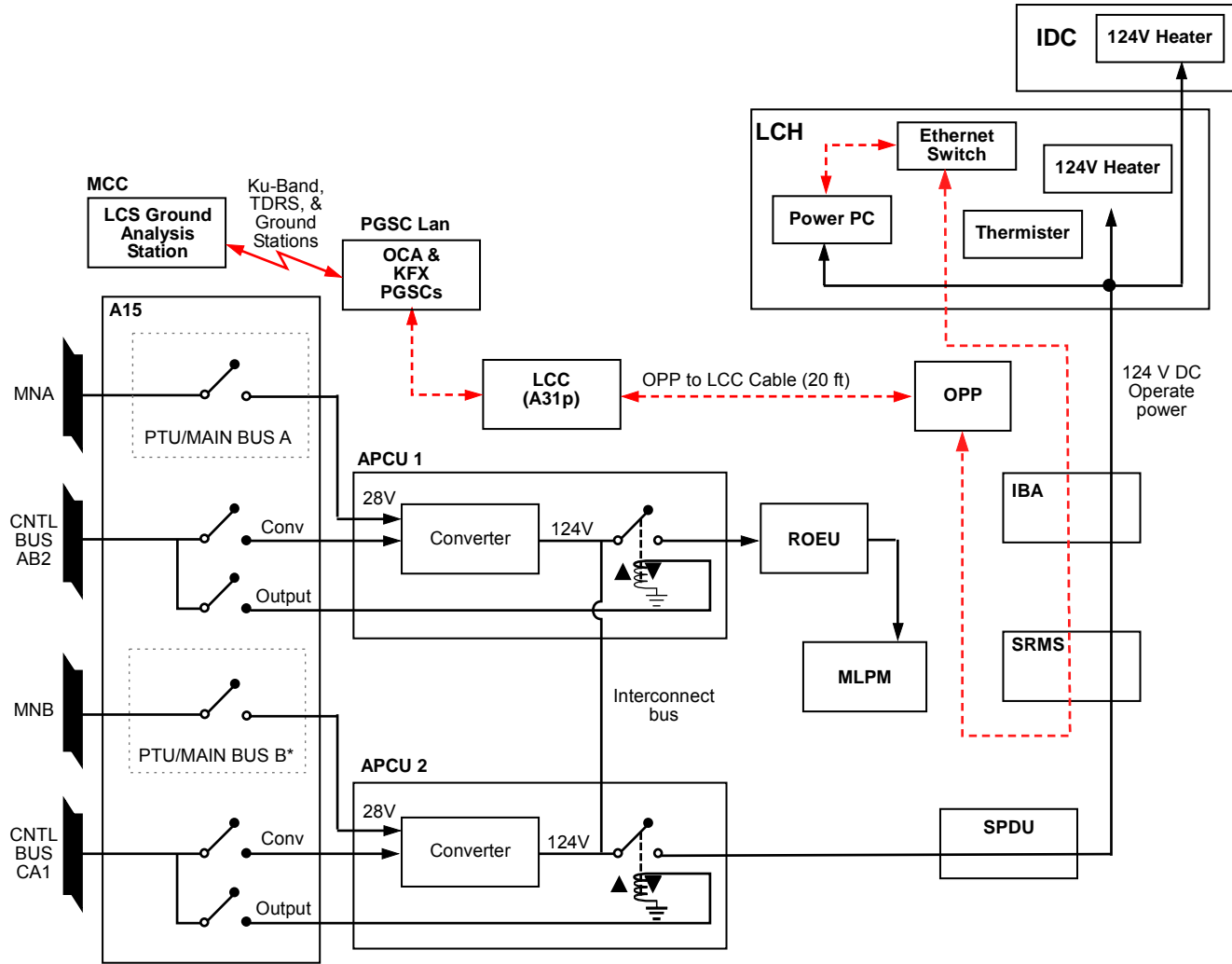

*See PTU 2/MAIN BUS B for detailed system dwg

jsc48038_131_134cr1.cvx

LASER CAMR SYSTEM (LCS)/INTEGRATED SENSOR INSPECTION SYSTEM DIGITAL CAMR (IDC) (Concluded)

PTU 2/MAIN BUS B SYSTEM DETAILS

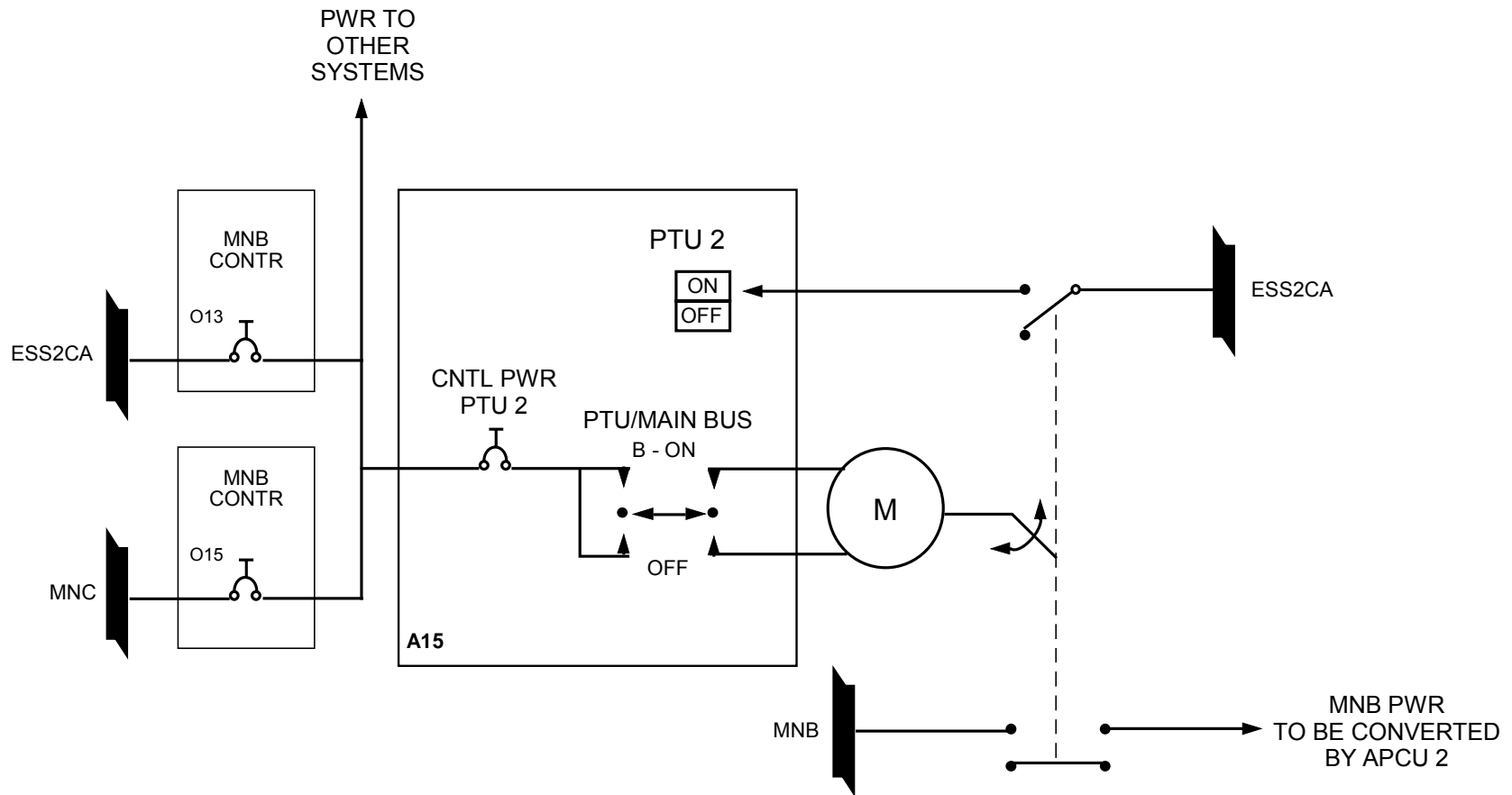

jsc48037_PTU2_134e.cvx

This Page Intentionally Blank

This Page Intentionally Blank

SPECIFICATIONS

CAMR BODY

CMOS SENSOR SIZE: 36mm x 23.9mm (DX MODE 24mm x 16mm)
PIXEL COUNT: 4256 x 2832 (12.1 million pixels)
FRAME/CARD: ~202/4 GB EVA Flash Card
RAW FILE SIZE: ~11.3 MB compressed lossless (12-bit)
EXPOSURE CONTROL: Auto (program, shutter priority, aperture priority), Manual
METER PATTERN: 3D Color Matrix II, Center Weighted, Spot
EXPOSURE COMP: ± 5 EV RANGE in 1/2 or 1/3 EV steps
SHUTTER:
 Program & Aperture Priority – 1/8000 thru 30 sec (virtually stepless)
 Manual & Shutter Priority – 1/8000 thru 30 sec (1/3 or 1/2) stop increments), 250x, and Bulb (manual only)
ISO Setting: 200 to 12,800; H-0.3, H-0.5, H-0.7, H-1.0, H-2.0, H-3.0, L-0.3, L-0.7, and L-1.0 available (H-3.0 = 102,400 ISO)
FRAME RATE: Single continuous up to 9 frames/sec (up to 11 frames/sec in DX MODE)
 Burst Rate: 41 raw images
MOVIE MODE SIZES: 1280 x 720/24 fps, 640 x 420/24 fps, 320 x 260/24 fps
MOVIE FORMAT: AVI
MOVIE COMPRESSION: Motion JPEG
MOVIE ISO: 200-12,800
MOVIE RECORDING TIME: 5 min max in 1280 x 720, 20 min max in other movie modes
MOVIE FILE SIZE: Max 2 GB
CAMERA INTERFACES: USB, audio/video, HDMI, Microphone, 10-pin remote
CAMR BATT: Li-ION EN-EL4A
CAMR BATT VOLTAGE: 11.1VDC
CAMR WEIGHT: 3.2 lb (w/Batt & Memory Card)

FLASH

SB-800 DX
BATT: 4AA
BATT LIFETIME: 200+ images
WEIGHT: w/o Batts – .77 lb
SYNC FLASH CONTROL: Master, Remote

D3s (Continued)

LENS DATA

NOTE

Do not use non-AF lens w/D3s

Lens	Aperture Range (f/stop)	Approximate Field of View (FOV)			Approx Minimum Focus Distance (ft)	Weight (lb)	Filter Size	M-A Switch
		Horizontal	Vertical	Diagonal				
10.5mm AF DXG	f/2.8-f/22	–	–	180°	0.5	.6	Rear	
12-24mm AF DX	f/4.0-f/22	89°-53°	66°-36°	100°-61°	1.0	1.02	77mm	Yes
14mm	f/2.8-f/22	104°	81°	114°	0.66	1.48	Rear	Yes
16mm	f/2.8-f/22	97°	74°	107°	0.9	0.6	Rear	
17-35mm	f/2.8-f/22	93°-54°	70°-38°	104°-63°	1.0	1.6	77mm	Yes
24-70mm	f/2.8-f/22	74°-29°	53°-19°	84°-34°	1.2	2.0	77mm	Yes
17-55mm	f/2.8-f/22	70°-24°	50°-16°	80°-29°	1.3	1.7	77mm	Yes
20-35mm	f/2.8-f/22	61°-37°	43°-25°	71°-44°	1.7	1.3	77mm	Yes
24-85mm	f/2.8(4)-f/22	53°-16°	36°-11°	61°-19°	1.6	1.2	72mm	Yes
28mm	f/2.8-f/22	46°	31°	54°	1.25	0.5	52mm	
28mm	f/1.4-f/16	46°	31°	54°	1.14	1.1	72mm	Yes
28-70mm	f/2.8-f/22	46°-19°	31°-13°	54°-23°	2.3 (1.5 ft macro)	2.0	77mm	Yes
35mm	f/2-f/22	54°	38°	63°	0.9	0.5	52mm	
35-70mm	f/2.8-f/22	54°-29°	38°-19°	63°-34°	2.0 (0.9 ft macro)	1.5	62mm	
50mm	f/1.4-f/16	40°	27°	47°	1.5	0.5	52mm	
58mm Noct MF	f/1.2-f/16	35°	23°	41°	2	1.1	52mm	
60mm Micro	f/2.8-f/32	33°	23°	40°	0.66	1.0	62mm	Yes
80-200mm	f/2.8-f/22	25°-10°	17°-7°	30°-12°	6	2.87	77mm	Yes
80-400mm VR	f/4.5(5.6)-f/32	25°-5°	17°-3°	30°-6°	7.5	2.96	77mm	Yes
85mm	f/1.8-f/16	24°	16°	29°	3.0	1.2	62mm	

D3s (Continued)

LENS DATA (Concluded)

Lens	Aperture Range (f/stop)	Approximate Field of View (FOV)			Approx Minimum Focus Distance (ft)	Weight (lb)	Filter Size	M-A Switch
		Horizontal	Vertical	Diagonal				
105mm Micro	f/2.8-f/32	20°	13°	23°	1.0	1.2	52mm	Yes
180mm	f/2.8-f/22	11°	8°	14°	5.0	1.7	72mm	Yes
200-400mm VR	f/4-f/32	10°-5.2°	7°-3.4°	12°-6.2°	6.6	7.2	52mm	Yes
400mm	f/2.8-f/22	5.2°	3.4°	6.2°	12.5	10.6	52mm	Yes
400mm w/2X Teleconverter (800mm) TC-20E	f/5.6-f/45	2.6°	1.7°	3.1°	12.5	11.3	52mm	Yes
Sigma 300-800mm	f/5.6-f/32	6.9°-2.6°	4.6°-1.7°	8.2°-3.1°	19.7	12.7	46mm	

D3s (Continued)

NOMENCLATURE

CAMR – FRONT

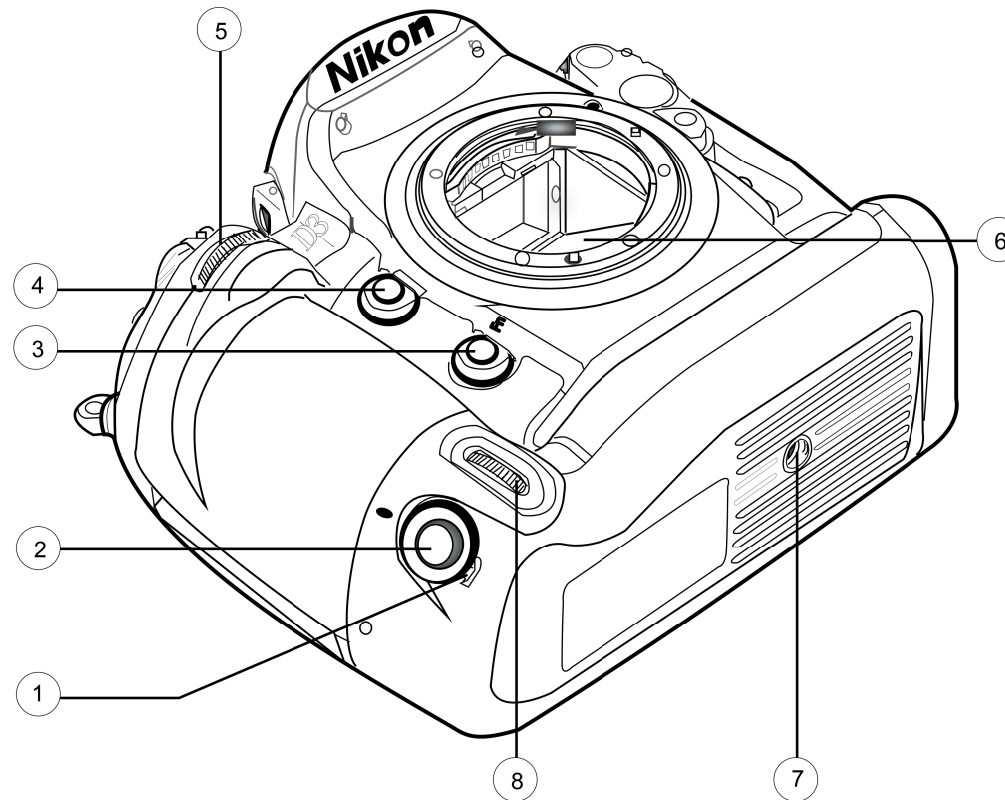

Nikon D3s Camera Front

- | | | | |
|---|---|---|--------------------------------------|
| 1 | sw Shutter-release Lock (vertical shooting) | 5 | Sub-command Dial |
| 2 | pb Shutter-release (vertical shooting) | 6 | Mirror |
| 3 | pb Fn | 7 | 1/4-20 Socket |
| 4 | pb Depth-of-field Preview | 8 | Sub-command Dial (vertical shooting) |

jsc48038_131_152r1.cvx

D3s (Continued)

NOMENCLATURE (Continued)

CAMR – BACK

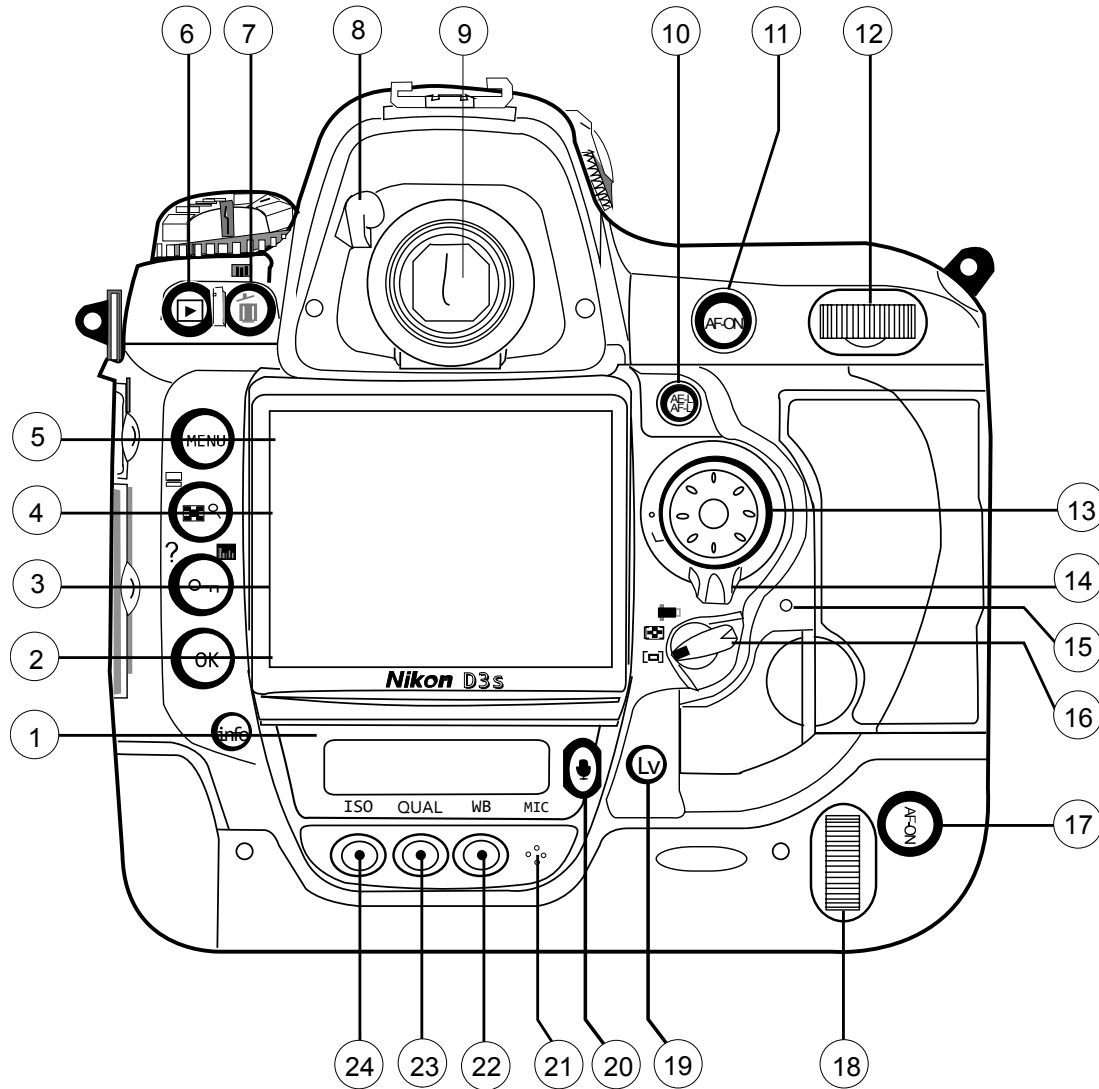

Nikon D3s Camera Back

- | | |
|--------------------------|--|
| 1 pb info | 13 Navigate Pad |
| 2 pb OK | 14 Focus Selector Lock |
| 3 pb Protect | 15 Memory Card Busy Lamp |
| 4 pb Thumbnail/Zoom | 16 AF-Area Mode Selector |
| 5 pb MENU | 17 pb AF-ON (vertical shooting) |
| 6 pb Playback | 18 Main Command Dial (vertical shooting) |
| 7 pb Delete | 19 pb Live View |
| 8 Eyepiece Shutter Lever | 20 pb Microphone |
| 9 Viewfinder Eyepiece | 21 Microphone |
| 10 pb AE/AF Lock | 22 pb White Balance |
| 11 pb AF-ON | 23 pb QUAL (image quality/size) |
| 12 Main Command Dial | 24 pb ISO Sensitivity |



jsc48038_131_153r1.cvx

D3s (Continued)

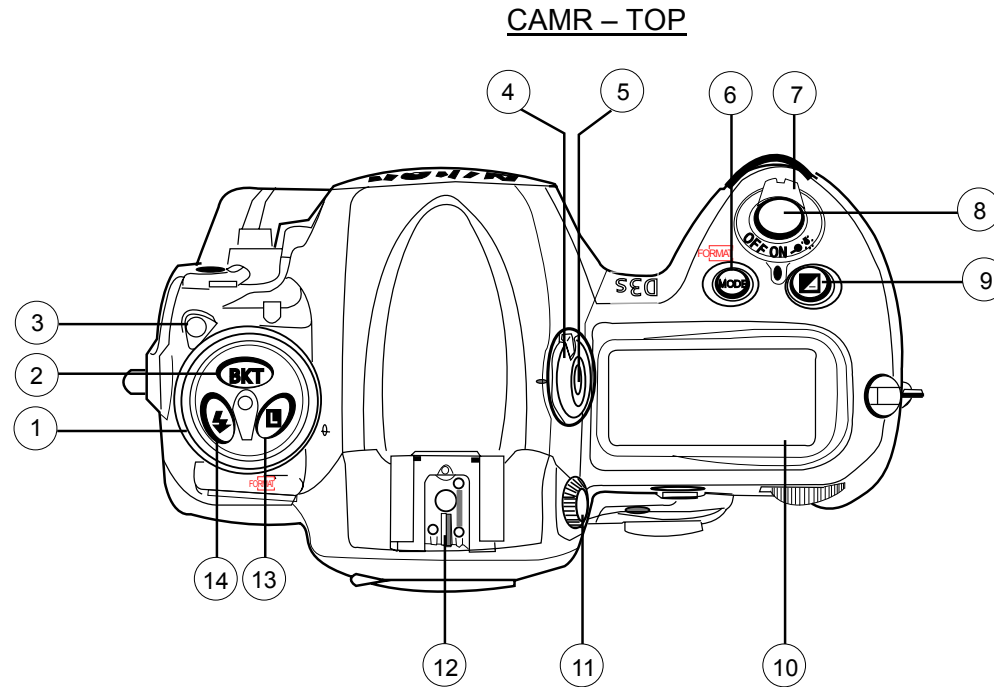
NOMENCLATURE (Continued)



Nikon D3s Camera Top

- | | | | |
|---|---------------------------------|---|--|
| ① | Shooting mode dial | ⑧ | pb Shutter-release |
| ② | pb Bracketing (BKT) | ⑨ | pb Exposure compensation  |
| ③ | Shooting mode dial lock release | ⑩ | Top LCD |
| ④ | Metering selector | ⑪ | Diopter adjustment knob |
| ⑤ | pb Metering selector lock | ⑫ | Accessory shoe |
| ⑥ | pb Exposure mode (MODE) | ⑬ | pb Lock |
| ⑦ | sw Power | ⑭ | pb Flash Mode  |

jsc48038_131_154r1.cvx

D3s (Continued)

NOMENCLATURE (Continued)

CAMR – LEFT SIDE

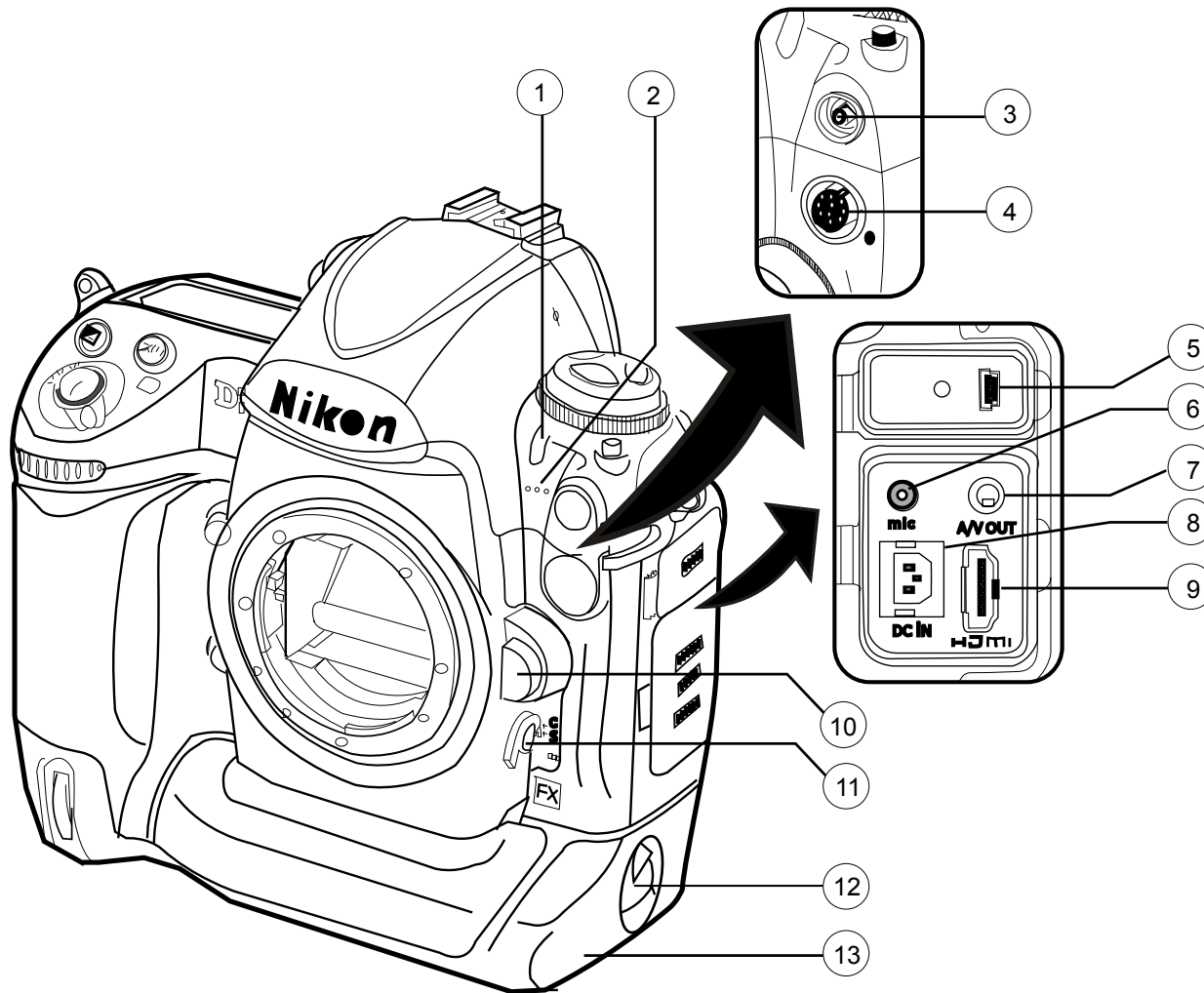

- ① Self-timer Lamp
- ② Microphone (for movies)
- ③ Flash Sync Terminal
- ④ Ten-pin Remote Terminal
- ⑤ USB Connector
- ⑥ Microphone Port
- ⑦ Audio/Video (A/V) Connector
- ⑧ DC-IN Connector for optional AC Adapter EH-6
- ⑨ HDMI Connector
- ⑩ Lens Release Button
- ⑪ Focus-mode Selector
- ⑫ Battery Door Latch
- ⑬ Battery Door

Nikon D3s Camera Left Front
FS 2-36

D3s (Continued)

NOMENCLATURE (Continued)

CAMR – TOP CONTROL PANEL

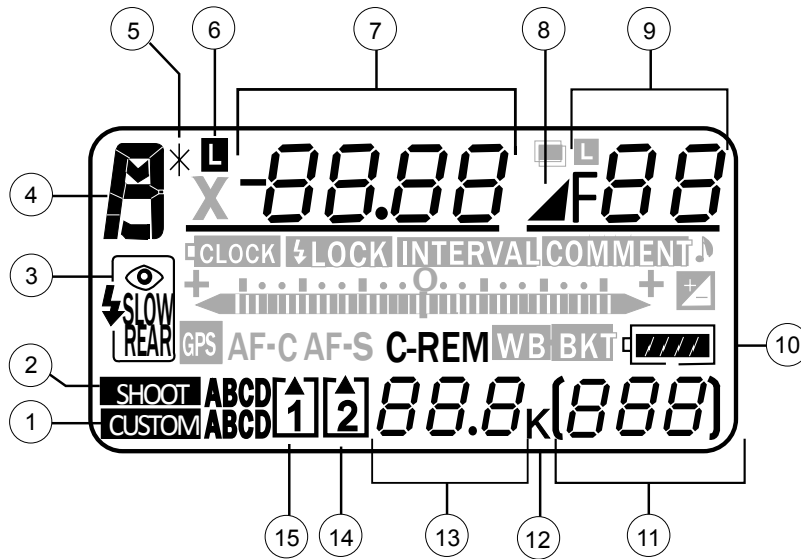

Nikon D3s Camera Top Control Panel - 1

- | | |
|------------------------------|--|
| ① Custom settings bank | ⑨ Aperture (f/number) |
| ② Shooting menu bank | ⑩ Battery indicator |
| ③ Flash mode | ⑪ Frame count |
| ④ Exposure mode | ⑫ "K" (indicates memory remains for over 1000 exposures) |
| ⑤ Flexible program indicator | ⑬ Number of exposures remaining |
| ⑥ Shutter-speed lock icon | ⑭ Memory card indicator (slot 2) |
| ⑦ Shutter speed | ⑮ Memory card indicator (slot 1) |
| ⑧ Aperture delta | |

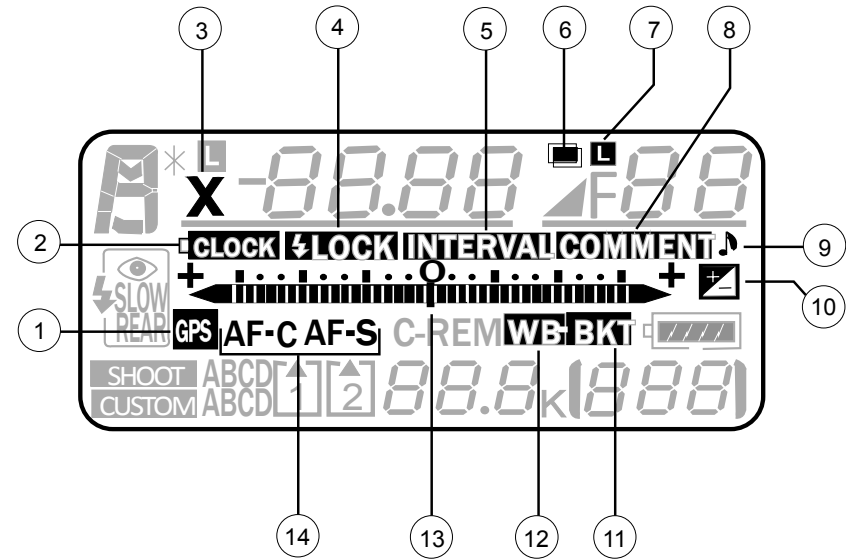

Nikon D3s Camera Top Control Panel - 2

- | | |
|-------------------------------|---|
| ① GPS connection indicator | ⑧ Image comment indicator |
| ② Clock battery indicator | ⑨ "Beep" indicator |
| ③ Flash sync indicator | ⑩ Exposure compensation indicator |
| ④ FV lock indicator | ⑪ Exposure and flash bracketing indicator |
| ⑤ Interval timer indicator | ⑫ White balance bracketing indicator |
| ⑥ Multiple exposure indicator | ⑬ Electronic analog exposure display |
| ⑦ Aperture lock icon | ⑭ Focus mode indicator |

jsc48038_131_156r1.cvx

D3s (Continued)

NOMENCLATURE (Continued)

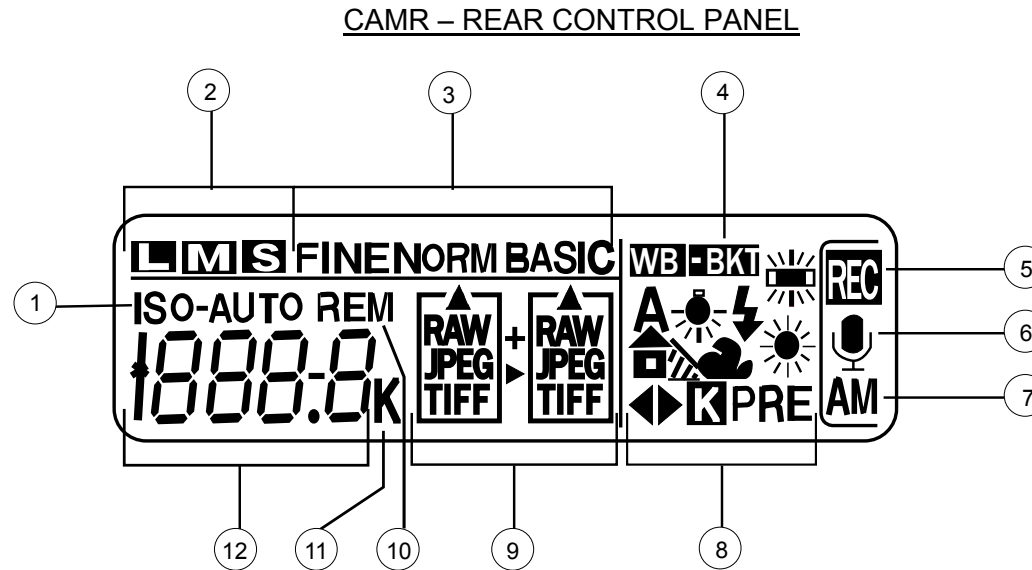

Nikon D3 Camera Back Panel

- | | |
|---|--|
| <p>① ISO sensitivity indicator</p> <p>② Image size (JPEG and TIFF images)</p> <p>③ Image quality (JPEG images)</p> <p>④ White-balance bracketing indicator</p> <p>⑤ Voice memo recording indicator (shooting mode)</p> <p>⑥ Voice memo status indicator</p> | <p>⑦ Voice memo recording mode</p> <p>⑧ White balance</p> <p>⑨ Memory card slot indicators</p> <p>⑩ "Remaining" indicator</p> <p>⑪ "K" (indicates memory remains for over 1000 exposures)</p> <p>⑫ ISO sensitivity</p> |
|---|--|

jsc48038_131_157r1.cvx

D3s (Continued)





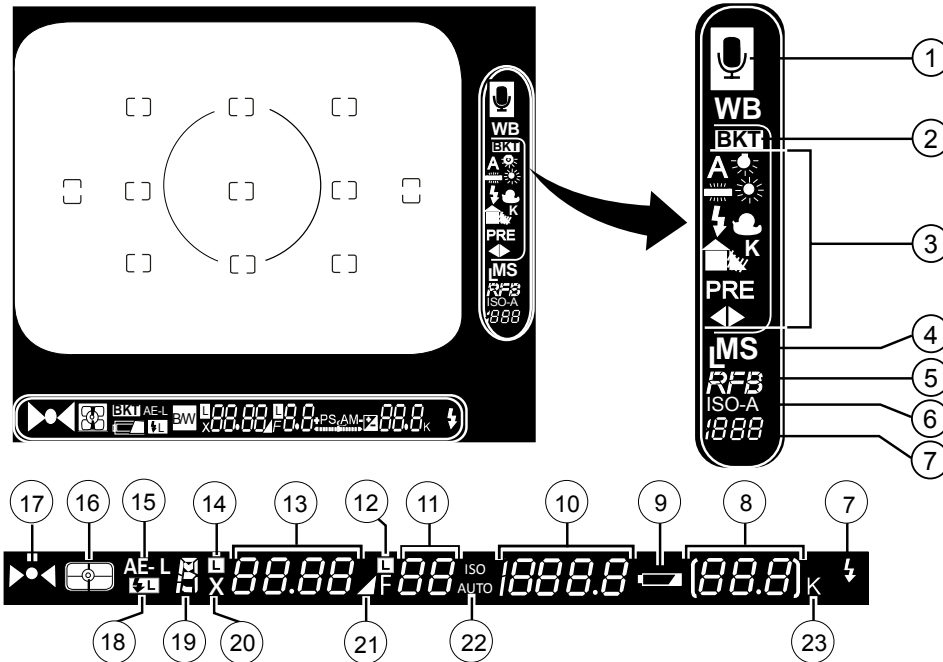







NOMENCLATURE (Continued)

VIEWFINDER DISPLAY – LOWER BAR



- ① Voice Memo Status Indicator
- ② White Balance Bracketing Indicator
- ③ White Balance Mode
- ④ Image Size
- ⑤ Image Quality
- ⑥ ISO Sensitivity Indicator
Auto ISO Sensitivity Indicator
- ⑦ ISO Sensitivity

D3s Viewfinder Display



- | | | |
|---|---|---|
| ① Focus Points | ⑨ Battery Indicator () | ⑰ Focus Indicator () |
| ② AF Area Brackets | ⑩ ISO Sensitivity () | ⑱ FV Lock Indicator () |
| ③ 12-mm Reference Circle
for Center-weighted Metering | ⑪ Aperture | ⑲ Exposure Mode () |
| ④ Exposure Indicator | ⑫ Aperture Lock Icon () | ⑳ Flash Sync Indicator () |
| ⑤ Exposure Compensation Indicator () | ⑬ Shutter Speed | ㉑ Aperture Stop Indicator () |
| ⑥ Exposure and Flash Bracketing
Indicator (BKT) | ⑭ Shutter Speed Lock Icon () | ㉒ ISO Sensitivity Indicator () |
| ⑦ Flash-ready Indicator () | ⑮ Auto Exposure Lock (AE-L) | ㉓ "K" (Appears when memory remains
for over 1000 exposures) |
| ⑧ Frame Count | ⑯ Metering () | |



jsc48038_131_158r1.cvx

D3s (Continued)



NOMINAL SETUP

D3s PROGRAM w/FLASH

Lens – as reqd
Aperture – Min, locked
Body Focus Mode – S
√Batt installed
√Flash Card installed
Pwr – ON
Top LCD
√Batt
√Frames remaining sufficient
Exp Comp () – 0.0
Exp Mode – P
Meter – Matrix ()
Diopter – Adjust
Frame Rate – S
√BKT disabled – 0 F
Rear LCD
√ISO – 200
√QUAL – RAW
√WB – 0,A
AF Area Mode – [[]]
Info pb – press
Focus Selector Lock – • (unlocked)
Focus Area – Center
Navigate Pad, Center – press
Focus Selector Lock – L

SB-800 Flash Settings
√Diffuser Dome installed
ON/OFF pb – ON
√MODE –  TTL 
√Exp Comp – 0 EV
Tilt – 45° (Direct)

D3s SHUTTER PRIORITY (EARTH OBS)

Lens – as reqd
Aperture – Min, locked
Body Focus Mode – S
√Batt installed
√Flash Card installed
Pwr – ON
Top LCD
√Batt
√Frames remaining sufficient
Exp Comp () – 0.0
Exp Mode – S
SS – 500
Meter – Matrix ()
Diopter – Adjust
Frame Rate – S
√BKT disabled – 0 F
Rear LCD
√ISO – 200
√QUAL – RAW
√WB – 0,A
AF Area Mode – [[]]
Info pb – press
Focus Selector Lock – • (unlocked)
Focus Area – Center
Navigate Pad, Center – press
Focus Selector Lock – L

SB-800 Flash Settings
ON/OFF pb – OFF

D3s (Continued)

NOMINAL SETUP (Continued)

D3s MANUAL (SUNLIT OBJECT)

SB-800 Flash Settings
ON/OFF pb – OFF

Lens – as reqd
Aperture – Min, locked
Body Focus Mode – S
√Batt installed
√Flash Card installed
Pwr – ON
Top LCD
√Batt
√Frames remaining sufficient

Exp Comp () – 0.0

Exp Mode – M
SS – 1000
f/stop – f8

Meter – Matrix ()
Diopter – Adjust
Frame Rate – S
√BKT disabled – 0 F
Rear LCD
√ISO – 200
√QUAL – RAW
√WB – 0,A

AF Area Mode – [[]]
Info pb – press
Focus Selector Lock – • (unlocked)
Focus Area – Center
Navigate Pad, Center – press
Focus Selector Lock – L

D3s AURORA/AIRGLOW

Lens – as reqd

Lens Focus Mode – A
Aperture – Min, locked
Body Focus Mode – S
√Batt installed
√Flash Card installed
Pwr – ON
Top LCD
√Batt
√Frames remaining sufficient
Exp Comp () – 0.0

Exp Mode – M

SS – 1"
f/stop – maximum (smallest number)

Meter – Matrix ()
Diopter – Adjust
√BKT disabled – 0 F
Rear LCD

√ISO – 12,800

√QUAL – RAW
√WB – 0,A

AF Area Mode – [[]]

Info pb – press

Focus Selector Lock – • (unlocked)

Focus Area – Center

Navigate Pad, Center – press

Focus Selector Lock – L

SB-800 Flash Settings
ON/OFF pb – OFF

Technique

1. Dim cabin lights
2. Use dark clothing to shield window
3. Focus, Frame, Fire

D3s (Continued)

NOMINAL SETUP (Concluded)

D3s CITY LIGHTS/STARS

Lens – as reqd

Lens Focus Mode – A
Aperture – Min, locked
Body Focus Mode – S
√Batt installed
√Flash Card installed
Pwr – ON
Top LCD
√Batt
√Frames remaining sufficient

Exp Comp () – 0.0

Exp Mode – M

SS – 15

f/stop – maximum (smallest number)

Meter – Matrix ()

Diopter – Adjust

√BKT disabled – 0 F

Rear LCD

ISO – 12,800

√QUAL – RAW

√WB – 0,A

AF Area Mode – [[]]

Info pb – press

Focus Selector Lock – • (unlocked)

Focus Area – Center

Navigate Pad, Center – press

Focus Selector Lock – L

SB-800 Flash Settings

ON/OFF pb – OFF

Accessory Equipment

Shutter Release Cable – Install

Multiuse Brkt, Clamp – Install

Technique

1. Dim cabin lights
2. Use dark clothing to shield window
3. Focus, Frame, Fire

D3s LIGHTNING

Lens – as reqd

Lens Focus Mode – A
Aperture – Min, locked
Body Focus Mode – S
√Batt installed
√Flash Card installed
Pwr – ON
Top LCD
√Batt
√Frames remaining sufficient

Exp Comp () – 0.0

Exp Mode – M

SS – 2"

f/stop – maximum (smallest number)

Meter – Matrix ()

Diopter – Adjust

Frame Rate – S

√BKT disabled – 0 F

Rear LCD

ISO – 400

√QUAL – RAW

√WB – 0,A

AF Area Mode – [[]]

Info pb – press

Focus Selector Lock – • (unlocked)

Focus Area – Center

Navigate Pad, Center – press

Focus Selector Lock – L

SB-800 Flash Settings

ON/OFF pb – OFF

Accessory Equipment

Shutter Release Cable – Install

Multiuse Brkt, Clamp – Install as reqd

Technique



1. Fire Camr repeatedly. Luck reqd

D3s (Continued)





DATE/TIME SET

1. MENU pb – press
Set TIME ZONE
2. Navigate pad – sel menu icon  SETUP MENU
 - press (right)
 - sel TIME ZONE and DATE (up,down)
 - press (right)
 - sel TIME ZONE (up,down)
 - press (right)
 - sel LONDON, CASABLANCA (left,right)
 - OK pb – press
3. Set DATE/TIME to GMT
Navigate pad – sel DATE and TIME (up,down)
 - sel desired field (left,right)
 - sel desired setting (up,down)
4. OK pb – press
5. MENU pb – press twice

DELETING SINGLE IMAGES



1. PLAYBACK  pb – press
2. Navigate pad – sel image (left,right)
3. DELETE  pb – press twice to delete

ADDING .WAV FILES TO AN IMAGE



1. PLAYBACK  pb – press
2. Navigate pad – sel image (left,right)
3. MICROPHONE  pb – press, hold (✓microphone icon  appears on upper left of rear LCD)
4. Talk to MIC
5. ✓Music Note icon  appears in upper left image

D3s (Concluded)

DELETING .WAV FILE FROM AN IMAGE

1. PLAYBACK  pb – press
2. Navigate pad – sel image (left,right)
3. DELETE  pb – press
4. Sel – Sound only
5. DELETE  pb – press

.WAV FILE PLAYBACK

1. PLAYBACK  pb – press
2. Navigate pad – sel image w/music note  (left,right)
3. MICROPHONE  pb – press

CUE CARD CONFIGURATION

	<u>PAGE</u>
TV	FS CC 3-3
ANALOG PLAYBACK.....	FS CC 3-5
ET PHOTO	FS CC 3-7
MEDIA ALLOCATIONS	FS CC 3-8
WVS.....	FS CC 3-10
PLBD VTR RECORDING	FS CC 3-12
LDRI/ITVC	FS CC 3-14
LCS.....	FS CC 3-16
IDC.....	FS CC 3-18
VIDEO SETUP.....	FS CC 3-20
D2Xs SETUP	FS CC 3-22
LDRI/ITVC A7 PLACARD.....	FS CC 3-24
DIGITAL PLAYBACK.....	FS CC 3-25
G1 CC SETUP	FS CC 3-27

CUE CARDS

This Page Intentionally Blank

HOOK
VELCRO

TV

ACTIVATION

A3 MON 1(2) PWR – ON (LED ON)
 A7 √TV DNLK – ENA
 PWR CONTR UNIT – MNA(B)
 CNTL – PNL, wait 10 sec for system initialization, CMD

OPERATION**Auto Ops (Auto Exposure)**

A7 √MCC has commanded sync config
 TV CAMR PWR A(B,C,D,RMS) – ON (tb-ON)
 VID OUT MON 1(2) pb – push
 IN pb – as reqd
 If CTVC:
 ALC pb – push
 AVG pb – push
 If ITVC:
 If MAN GAIN pb not illuminated:
 TV CAMR PWR A(B,C,D,RMS) – OFF, wait 10 sec, ON
 Repeat until MAN GAIN pb illuminated
 LT LEVEL pb – push
 DAY(NIGHT) pb – push
 ALC pb – push
 AVG pb – push

Dnlk Ops

Coordinate dnlk and sync config w/MCC
 Config audio as reqd

A7 If analog, on MCC GO:
 VID OUT DNLK pb – push
 IN pb – as reqd
 If DTV, on MCC GO:
 L10 √Cables connected
 (MUX) MUX/VTR/CC PWR – on (LED on)
 √MUX BYPASS – ACT
 (VIP) PWR – on (LED on, DATA FLOW LED flashes twice)
 (VTR) √ON/STANDBY LED – green
 A7 √INPUT SELECT – VIDEO
 VID OUT DTV pb – push
 IN pb – as reqd

L10 √DATA FLOW LED – on
 (VIP) √CH 3 DATA LED – on
 (MUX)

DEACTIVATION

If Illuminator ON:
 Refer to Illuminator Ops and perform Illuminator OFF

A7 PORT RMS CAMR – WRIST
 TV CAMR PWR A(B,C,D,RMS) – OFF (tb-OFF), wait 10 sec
 PORT RMS CAMR – ELBOW
 TV CAMR PWR RMS – ON (tb-on), wait 10 sec, OFF (tb-OFF)
 If Keel:
 L12 MPLM KEEL CAM PWR – OFF
 (SSP 2B) √HTR/ILLUM PWR – ON
 A7 TV PWR CNTL – PNL
 CONTR UNIT – OFF
 CNTL – CMD
 A3 MON 1,2 PWR – OFF

If DTV:
 L10 ON/STANDBY pb – push (red LED on)
 (VTR) PWR – off (LED off)
 (VIP) MUX/VTR/CC PWR – off (LED off)
 (MUX) VTR/CC PWR – off (LED off)

Manual Ops – CTVC/ITVC (Manual Exposure)

CAUTION
 DO NOT LEAVE CAMRS UNATTENDED IN MANUAL
 MODE. DIRECT SUNLIGHT WILL DAMAGE CAMRS

Manual Exposure ON

A7 MAN GAIN pb – push
 0(+12,+24) dB pb – push
 CAMR CMD IRIS – OP,CL

Return to Auto Exposure

ALC pb – push
 AVG pb – push

MUX Ops

NOTE
 Although dnlk/red is in color, MON
 will display MUX in B&W

A7 VID OUT MON pb – as reqd
 IN MUX 1(2) pb – push
 OUT MUX 1(2) L pb – push
 IN pb – As reqd
 OUT MUX 1(2) R pb – push
 IN pb – as reqd

For RSC ops:
 Go to LDR/ITVC Cue Card

Keel Camr

L12 √cb SW PWR 3 – cl
 (SSP 2B) √MPLM KEEL CAM HTR/ILLUM PWR – ON
 PWR – ON

P/TV-1a/131/O/A

(reduced copy)

FS CC 3-3

P/TV/131/FIN

TOP
BACK OF 'TV'

HOOK
VELCRO

Illuminator Ops

Illuminator ON

L12 (SSP 2B) If MPLM Keel Illuminator:
 \cb CB2 - cl
 \MPLM KEEL CAM PWR - ON
 HTR/ILLUM PWR - OFF, ON for HI (repeat for MED, LOW, OFF)

R14:D(E) If Wrist Illuminator:
 \cb TV RMS CAMR/PTU - cl
 \WRIST ILLUM/CAMR HTR - cl - op, cl

If Elbow Illuminator
 \cb TV RMS CAMR/PTU - cl
 \ELB ILLUM/PTU HTR - cl - op, cl

If A(B,C,D,ELB) Illuminator:
 \cb TV A(B,C,D,RMS,ELB) CAMR/PTU - cl
 \ILLUM/PTU HTR - cl - op, cl

Illuminator OFF

L12 (SSP 2B) If MPLM Keel Illuminator:
 MPLM KEEL CAM HTR/ILLUM PWR - toggle until Illuminator OFF (leave sw in ON posn)

R14:D(E) If Wrist Illuminator:
 cb TV RMS WRIST ILLUM/CAMR HTR - op, cl

If Elbow Illuminator:
 cb TV RMS ELB ILLUM/PTU HTR - op, cl

If A(B,C,D) Illuminator:
 cb TV A(B,C,D) ILLUM/PTU HTR - op, cl

If RSC Illuminator:
 Go to LDR/ITVC (Cue Card)

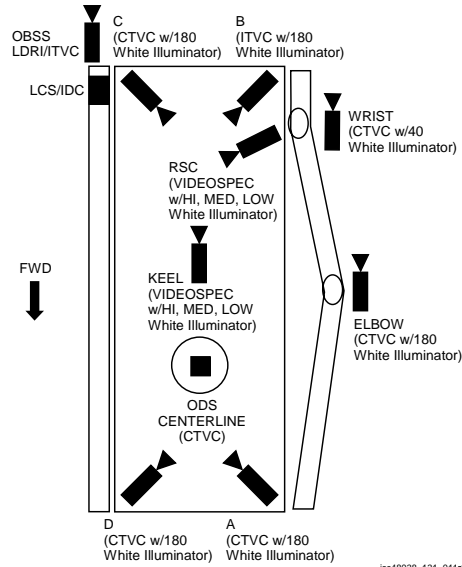

jsc48038_131_011r2.cvx

P/TV-1b/131/O/B

(reduced copy)

FS CC 3-4

P/TV/131/FIN 1

HOOK
VELCRO

ANALOG PLAYBACK

ANALOG VIA CC

NOTE

Analog Playback from CC only possible for CC Video recordings

ACTIVATION

CC Setup per diagram (back of cue card)
 A7 Perform ACTIVATION (Cue Card, TV), as reqd
 O19 √TV PWR – ON

AVIU SYNC/VIDEO – VIDEO
 HI-Z/75 – 75
 PWR SELECT – LO

CC PWR – VTR/PLAY
 √A/V1/V2 – V2

OPERATIONSPLBK or DNLK VIDEO

CC Install tape, if reqd

If audio reqd:
 CCU If MHA, COMM PWR – ON
 ATU PWR – AUD
 Desired Loops – T/R
 Other Loops – RCV(OFF)
 XMIT/ICOM Mode – VOX/VOX
 VOX SENS – MAX

CC Speaker Vol Max

A7 VID OUT MON pb – as reqd
 IN FLT DECK(MIDDECK) pb – push

CC VTR pb – REW(FF) to cue tape

If Dnlk

A7 √MCC has commanded async config
 √TV DNLK – ENA
 VID OUT DNLK pb – push
 IN FLT DECK(MIDDECK) pb – push

CC PLAY pb – push (green ► displayed)

If PLBK(DNLK) complete:
 | STOP pb – push
 If CC ops complete, go to DEACTIVATION

DEACTIVATION

CC Remove, mark, stow tape as reqd
 PWR – OFF

ATU Reconfig as desired

O19 TV PWR – OFF, as reqd
 Go to DEACTIVATION (Cue Card, TV), as reqd

ANALOG VIA VTR

ACTIVATION

Setup per diagram (back of cue card)
 Disconnect CC Video input from AVIU J3
 Perform ACTIVATION (Cue Card, TV) as reqd
 O19 √TV PWR – ON

AVIU SYNC/VIDEO – VIDEO
 HI-Z/75 – 75
 PWR SELECT – LO

L10 (MUX) √VTR/CC PWR – on (LED on)
 (VTR) √ON/STANDBY LED – green

OPERATIONSPLBK or DNLK VIDEO

L10 (VTR) Install tape if reqd
 √DISPLAY SELECT – DATA

(VIP) If audio reqd:
 PWR – on (LED on, DATA FLOW LED
 flashes twice)

CCU ATU – PBK/KEY MIC (Amber LED on)
 If MHA, COMM PWR – ON
 PWR – AUD
 Desired Loops – T/R
 Other Loops – OFF
 XMIT/ICOM Mode – VOX/VOX
 VOX SENS – MAX

A7 VID OUT Desired MON pb – push
 IN FLT DECK pb – push

L10 (VTR) REW(FF),PLAY,PAUSE pb – push as reqd to
 cue tape

If Dnlk

A7 √MCC has commanded async config
 √TV DNLK – ENA
 VID OUT DNLK pb – push
 IN FLT DECK pb – push

L10 (VTR) PLAY pb – push (green • displayed)

If PLBK(DNLK) complete:
 | STOP pb – push
 If VTR ops complete, go to DEACTIVATION

DEACTIVATION

Connect CC video input to AVIU J3
 L10 (VTR) Remove, mark, stow tape as reqd

ATU Reconfig as desired

O19 TV PWR – OFF, as reqd
 Go to DEACTIVATION (Cue Card, TV) as reqd

P/TV-2a/131/O/A

(reduced copy)

FS CC 3-5

P/TV/131/FIN

TOP
BACK OF 'ANALOG PLAYBACK'

HOOK
VELCRO

ANALOG VIA CC PLAYBACK

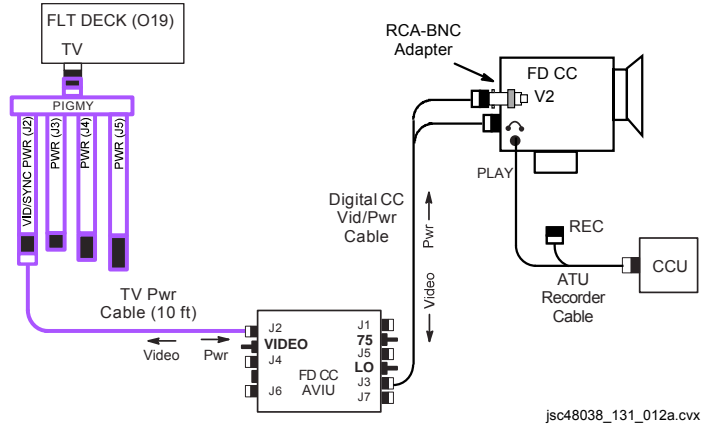

jsc48038_131_012a.cvx

ANALOG VIA VTR PLAYBACK

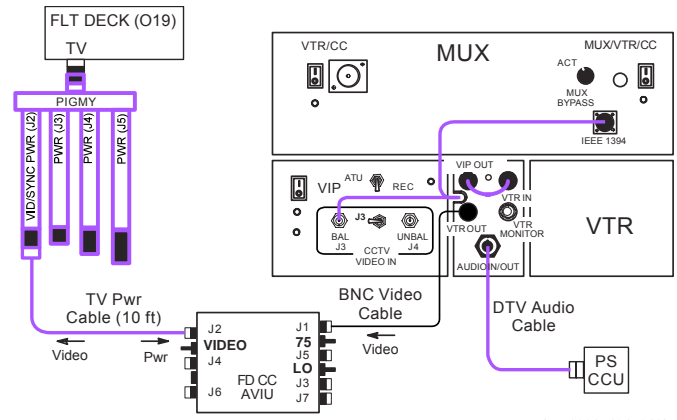

jsc48038_131_012b.cvx

P/TV-2b/131/O/A

(reduced copy)
FS CC 3-6

P/TV/131/FIN

TOP

HOOK
VELCRO

ET PHOTO

D2Xs D2Xs

LENS SETTINGS:

- √APERTURE – MIN, LOCKED
- √LENS FOCUS MODE – A

CAMR SETTINGS

PWR – ON
TOP LCD:

- √BATT
- √EXP MODE – M
- √SS – 1000
- √F/STOP – 8

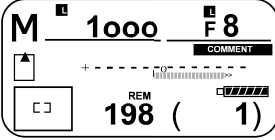

DIOPTR – ADJUST
√FRAME RATE – S
√BODY FOCUS MODE-S

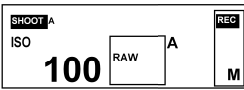

REAR LCD:

- √ISO – 100
- √QUAL – RAW

CRITICAL FOCUS REQD EACH FRAME

P/TV-3a/131/O/A

TOP
BACK OF 'ET PHOTO'

HOOK
VELCRO

ET PHOTO

G1 CC G1 CC

LENS CAP – REMOVE
INSTALL MUTING PLUG

- √ND FILTER – OFF
- √AF/M – M
- √AGC – OFF
- √GAIN – L
- √OUTPUT – CAM
- √AWB – ON
- √POWER dial – M
- √LOCK (handle) – off (aft)
- STANDBY/LOCK – STANDBY

OPEN LCD

- √BATT SUFFICIENT
- √EXP MODE – M
- √SS – 1/1000
- √GAIN – ±0dB
- √F/STOP – F8.0
- √FOCUS MODE – MF ∞

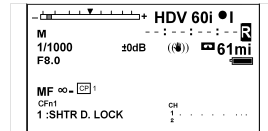

ZOOM – WIDE TO FIND TANK, THEN TIGHT

START RECORDING

- √LCD DISPLAYS RED DOT

P/TV-3b/131/O/B

TOP

MEDIA ALLOCATIONS										
DVCAM						3 hr/tape				
						15	14	13	12	11
10	9	8	7	6	5	4	3	2	1	
MINI DVCAM										
						224	223	222	221	
220	219	218	217	216	215	214	213	212	211	
210	209	208	207	206	205	204	203	202	201	
200	199	198	197	196	195	194	193	192	191	
190	189	188	187	186	185	184	183	182	181	
180	179	178	177	176	175	174	173	172	171	
170	169	168	167	166	165	164	163	162	161	
160	159	158	157	156	155	154	153	152	151	
150	149	148	147	146	145	144	143	142	141	
140	139	138	137	136	135	134	133	132	131	
130	129	128	127	126	125	124	123	122	121	
120	119	118	117	116	115	114	113	112	111	
110	109	108	107	106	105	104	103	102	101	
100	99	98	97	96	95	94	93	92	91	
90	89	88	87	86	85	84	83	82	81	
80	79	78	77	76	75	74	73	72	71	
70	69	68	67	66	65	64	63	62	61	
60	59	58	57	56	55	54	53	52	51	
50	49	48	47	46	45	44	43	42	41	
40	39	38	37	36	35	34	33	32	31	
30	29	28	27	26	25	24	23	22	21	
20	19	18	17	16	15	14	13	12	11	
10	9	8	7	6	5	4	3	2	1	
HI-8mm						2 hr/tape				
						4	3	2	1	

P/TV-4a/131/O/D

(reduced copy)

FS CC 3-8

P/TV/131/FIN 2

TOP
BACK OF 'MEDIA ALLOCATIONS'



HOOK
VELCRO

P/TV-4b/131/O/A



(reduced copy)
FS CC 3-9



P/TV/131/FIN

TOP

HOOK
VELCRO

HOOK
VELCRO

WVS

CAMR ADJUSTMENTS

ADJUST BRIGHTNESS

Course Adjustment

PGSC Select Page – RF Camera
Lens Iris Control – cl(op)

Fine Adjustment

PGSC Select Page – RF Camera
Electronic Shutter – Manual
Brightness – Dec(Inc)
(# to right: 100 = brightest; 0 = darkest)

DARK SUBJECT

PGSC Select Page – RF Camera
√Advanced Controls displayed
Automatic Gain Control – Enabled
(Disabled preferred)

PWRDN

For all lens (three) on each RF Camera Assy:
PGSC Lens Iris Control – Close until view black

Sel RF Camr 1,2 – None (black “OFF”)
V10 √Test Pattern displayed (color bars w/“No WVS
Video”)

PGSC Select Page – XCVR
Transceiver 1(2) CMD Pwr – Off
(black CMD PWR:LVL-“OFF:Min”)
Sel File → Exit

V10 STOP pb – push
Mark, stow tapes
PWR – OFF

A7 WIRELESS VID PWR – OFF
HTR – OFF

VIDEO SIGNAL PROBLEMS

For problem EMU TV:
EMU EMU TV Pwr pb – push (no LED), wait 10 sec, push
(green LED)

If no joy:
PGSC √Select Page – XCVR
√Advanced Controls displayed
For XCVR w/Video problem: IF – Narrow

If still no joy:
A7 WIRELESS VID PWR – OFF, wait 10 sec, ON

If still no joy:
PGSC For XCVR w/video problem: IF – Wide
For XCVR w/good video: Sel RF Camr – None (black ‘OFF’)
If video acceptable, other EMU TV interfering w/signal
Alternately sel EMU TVs to acquire video

If still no joy:
For XCVR with good video:
Sel RF Camr – reselect original EVA crewmember
For XCVR w/video problem: Antenna – Manual
Sel desired antenna

If still no joy:
For XCVR w/video problem: Antenna – Auto
√MCC

COMMANDING PROBLEM (UHF)

If commanding of WVS not visually seen:
PGSC Select Page – XCVR
Sel Transceiver 2(1) CMD Pwr – On
(green CMD PWR:LVL-“ON:Min”)

ANTENNA LOCATIONS

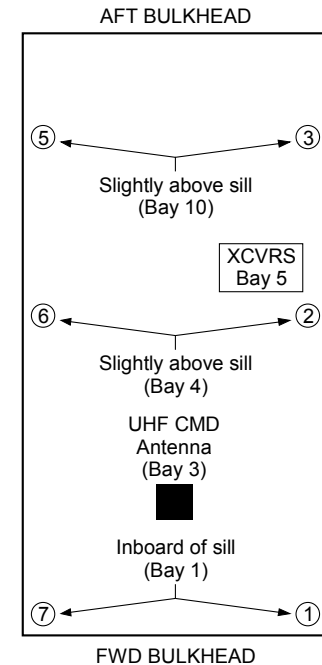

jsc48038_131_022r2.cvx

P/TV-5a/131/O/B

(reduced copy)

FS CC 3-10

P/TV/131/FIN

HOOK
VELCRO

HOOK
VELCRO

ALERT MSG TROUBLESHOOTING

STATIC XCVR

Condition: No comm between PGSC & PLB XCVR

- PGSC 1. √Cable connections between WIB and PGSC
- A7 2. WIRELESS VID PWR – OFF, wait 10 sec, ON
- If no joy:
- PGSC 3. Sel 'Start' > 'Shut Down' > 'Restart' > 'OK'
When reboot complete:
Sel Shuttle Apps icon > WVS icon
Sel 'Yes' at 'Restore To Previous Settings' window
RF Camera page will appear
- If still no joy:
- 4. √MCC

STATIC RF CAMERA

Condition: No telemetry and video received by PLB XCVR from EMU TV

- EMU 1. √EMU TV Pwr pb pushed (green LED)
- If no joy:
- PGSC 2. √Correct RF Camera selected via pulldown menu
√RF Camera (two) – ON (green "ON")
If not ON:
RF Camera (of static EMU TV) – sel "None" via pulldown menu, then sel original EMU TV
- If still no joy:
- 3. RF Camera 1(2) – sel 'None'
Perform CAMR ID ASSIGNMENT
Reattempt RF Camr selections
- If still no joy:
- 4. √CMD PWR:LVL – green "ON:Min" for XCVR 1(2)
If not ON:
Select Page – XCVR
Transceiver 1(2) CMD Power – On
(green CMD PWR:LVL - "ON:Min")
- If still no joy:
- EMU 5. EMU TV Pwr pb (of static EMU TV) – push (no LED), wait 10 sec, push (green LED)
- If still no joy:
- 6. √MCC

BAD CAMERA ID

Condition: Mismatch between EMU TV Camera ID and software camera ID

- PGSC 1. Select Page – XCVR:
Transceiver 1(2) CMD Power – On (green CMD PWR:LVL - "ON:Min")
Sel RF Camera 1,2 – None
Sel File > Assign Camera ID
√Camera IDs match data under CAMR ID ASSIGNMENT
If not a match:
Highlight entry, then sel 'Delete Entry' option
Perform CAMR ID ASSIGNMENT
Sel RF Camera 1,2 – EVA crewmembers
- If still no joy:
- 2. √MCC

TEMP ALERT (blue text)

Condition: EMU TV -35 °C to -30 °C OR 80 °C to 85 °C range
PLB XCVR -40 °C to -35 °C OR 80 °C to 85 °C range

- Select Page – Telemetry
- Identify component w/temperature alert (blue text)
- √MCC

TEMP CAUTION (yellow text)

Condition: EMU TV < -35 °C OR > 85 °C
PLB XCVR < -40 °C OR > 85 °C

- Select Page – Telemetry
- Identify component w/temperature alert (yellow text)
- √MCC

CAMR ID ASSIGNMENT

- Sel File → Assign Camr ID
- √All EV crewmembers listed as options on pulldown 'Label' menu under CAMERA ID SETUP

- If label entry reqd:
Type label into space next to "Add Label" icon
Sel "Add Label" icon to add to listing

Camr ID Data		
Camr Address	16	18
Serial Number	1010	1007
Label	EV1	EV2

- Under CAMERA ID SETUP:
Camera Address – As reqd via left/right arrows
Serial Number – As reqd via left/right arrows
Label – As reqd via pulldown menu
"In Use" Box – Check via single click
Sel "Save Entry" icon to right of Camr ID table (top)
- √Data entry visible in Camr ID table

Sel OK

P/TV-5b/131/O/A

(reduced copy)

TOP

HOOK
VELCRO

PLBD VTR RECORDING

- L10 √VIP,VTR covers removed
- R1 √PL AUX – ON
- MA73C:E cb AC2 PL3Φ – cl

- L10 √Cables config'd per dwg (back of cue card)
(MUX) VTR/CC PWR – on (LED on)
- (VIP) √ATU – REC
 √CCTV VIDEO IN – J3
 PWR – on (LED on, DATA FLOW flashes twice)
- (VTR) √ON/STANDBY LED – green

 √Switches set to white dot (seven)

 √COUNTER SELECT – COUNTER (TC)

 √Tape installed (tape icon LED on)

 Set GMT:
 DISPLAY SELECT – MENU
 ↓ pb – ETC, EXEC pb – push
 ↓ pb – CLOCK SET, EXEC pb - push
 Use ↓, ↑,EXEC to set Y,M,D,hr,min to GMT
 DISPLAY SELECT – DATA
- L9 If Audio desired:
 PS AUD PWR – AUD
 Desired Loops – RCV, Vol tw 5
 Other Loops – OFF
- A7 VID OUT DTV pb – push
 IN pb – as reqd
- L10 REC pb – push, hold
(VTR) PLAY pb – push, simo (red dot displayed)

P/TV-6a/131/O/A

(reduced copy)

FS CC 3-12

P/TV/131/FIN

TOP
BACK OF 'PLBD VTR RECORDING'

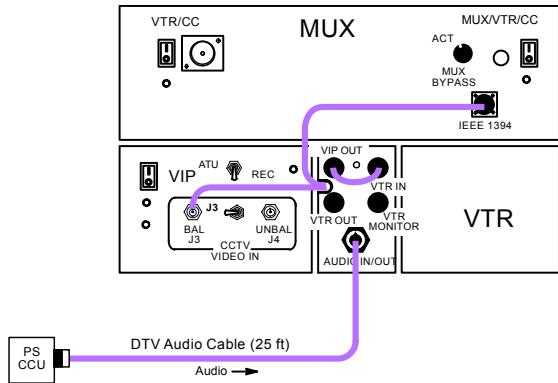
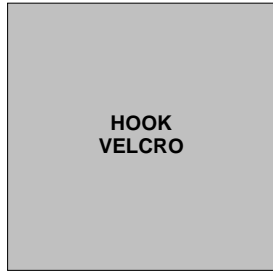

jsc48038_131_019r1.cvx

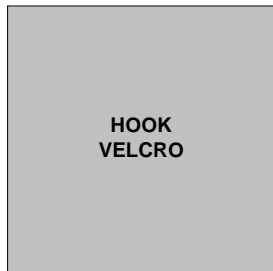

P/TV-6b/131/O/A

(reduced copy)
FS CC 3-13

P/TV/131/FIN

HOOK
VELCRO

LDRI/ITVC

HOOK
VELCRO

ACTIVATION

- Config CCTV Sys
 - A7 √ACTIVATION (Cue Card, TV) performed
 - L10 (MUX) √MUX/VTR/CC PWR – on (LED on)
 - √Cabling from VTR MON port to MON 2 C-IN
 - R12 (VPU) √VPU PWR – ON (LED on)
 - √Green Jumper – LDRI/ITVC
 - √RSC vid cable connected to WIB CCTV PL/3
 - MON 1,2 L-DATA – ON
 - C-DATA – GRN
 - X-HAIR – GRN
 - MON 2 SOURCE – C
- Apply SPEE Pwr
 - R12 (OPP) √cb OBSS SW PWR – cl
 - √OBSS SW PWR – ON
 - (OBSS) SPEE PWR – ON
 - A6U EVENT TIMER CNTL – STOP
 - RESET
 - CNTL – START
 - (15 min LDRI calibration warmup)
- Config RSC Illum to HI
 - A7 VID OUT MON 1 pb – push
 - IN C pb – push
 - PAN/TILT – Adjust to see RSC Camr
 - R12 (OBSS) SPEE PWR – OFF, wait 10 sec, ON
 - MON 1 √RSC illum on HI (three rings)
- Enable ITVC
 - √MCC has commanded sync config
 - R12 (OBSS) ITVC ENA – ON
 - A7 VID OUT DTV pb – push
 - IN PL 2(VPU) pb – push
 - If MAN GAIN pb not illuminated:
 - R12 (OBSS) ITVC ENA – OFF, wait 10 sec, ON
 - Repeat until MAN GAIN pb illuminated
 - A7 LT LEVEL pb – push
 - DAY (NIGHT) pb – push
 - ALC pb – push
 - AVG pb – push
 - MON 2 √ITVC video displayed
- Turn LDRI Laser On
 - A7 VID OUT MUX 1 L pb – push
 - IN MIDDECK pb – push
 - LDRI MODE 2 pb – push
 - VID OUT DTV pb – push, to return to ITVC control

GENERAL LDRI CONTROL

- A7 VID OUT MUX 1 L pb – push
- IN MIDDECK pb – push
- Mode 1 (default at pwrup)
- A7 LDRI MODE 1 pb – push
- MON 2 √ITVC video displayed
- Mode 2
- A7 LDRI MODE 2 pb – push
- MON 2 √ITVC video w/illum displayed
- Modes 3 (4,5,6)
- A7 LDRI MODE 3(4,5,6) pb – push
- MON 2 √LDRI w/rounded corners displayed
- To adjust brightness:
- A7 CAMR CMD IRIS – OP,CL, as reqd

PAN/TILT OPS WITH LDRI ACTIVE

- NOTE
- When adjusting pan/tilt in Modes 3(4,5,6), ITVC FOCUS (ZOOM, IRIS) cntls functional
- A7 VID OUT MON 1 pb – push
- IN PL2(VPU) pb – push
- CAMR CMD PAN,TILT – as reqd
- VID OUT MUX 1 L pb – push, to return to LDRI cntl

DEACTIVATION

- A7 VID OUT MUX 1 L pb – push
- √IN MIDDECK pb – lt on
- LDRI MODE 1 pb – push
- R12 (OBSS) ITVC ENA – OFF, pause 10 sec
- SPEE PWR – OFF
- A6U EVENT TIMER MODE – UP
- CNTL – START

LDRI MODE SUMMARY

Mode 1 – Standby

- ITVC video
- LDRI in standby

Mode 2 – Illuminator

- ITVC video w/illum
- LDRI laser active, LDRI camera inactive

Mode 3 – 2D

- LDRI 2D video
- Similar to ITVC video

Mode 4 – 2D Gamma

- LDRI 2D video w/Gamma Black Stretch
- Similar to ITVC video

Mode 5 – 3D

- LDRI 3D video
- Flicker on MON

Mode 6 – 3D Gamma

- LDRI 3D video w/Gamma Black Stretch
- Flicker on MON

P/TV-7a/131/O/A

(reduced copy)

FS CC 3-14

P/TV/131/FIN

TOP
BACK OF 'LDRI/ITVC'

HOOK
VELCRO

HOOK
VELCRO

RSC CAMR OPS

NOTE

Camr nominally pwr'd in Block 3 of
POST INSERT

R12 (OPP) cb OBSS SW PWR CB1 – cl
OBSS SW PWR – ON
(OBSS) RSC PWR – ON

RSC ILLUMINATOR OPS

NOTE

RSC illuminator OFF when SPEE PWR
sw initially taken to ON. A cycle of the
SPEE PWR sw takes RSC illuminator to
HIGH. Subsequent pwr cycles take
illuminator to MED, LOW, OFF and then
back to HIGH. Config may req alt Camr
view of RSC

R12 (OBSS) √SPEE PWR – ON
√RSC PWR – ON
ITVC ENA – OFF
A7 VID OUT MON 1 pb – push
IN A(B,C,D) pb – push
PAN,TILT – Adjust to see RSC Camr

NOTE

SPEE pwr cycle will reset LDRI/ITVC to
Mode 1 and reset the PTU angles

R12 (OBSS) SPEE PWR – OFF, wait 10 sec, ON
MON 1 √RSC illum on

To cycle thru illuminator modes:
R12 (OBSS) SPEE PWR – OFF, wait 10 sec, ON

Perform LDRI/ITVC ACTIVATION, step 4

Return to original LDRI/ITVC Mode, continue
OPS

CONTINGENCY LDRI CLEARANCE VIEW

NOTE

Do not apply RMS brakes

A8U AUTO SEQ – STOP (READY It on)

L10(VTR) STOP pb – push (no red ●)

A7 VID OUT MUX 1 L pb – push (MIDDECK It on)
LDRI MODE 3(4) pb – push (steady LDRI video)

VID OUT MON 1 pb – push
IN PL2(VPU) pb – push

Record PTU Pan _____ and Tilt _____

CAMR CMD PAN/TILT – HI RATE
PAN: 0 (left, to hard stop)
TILT: 0 (up, to hard stop)

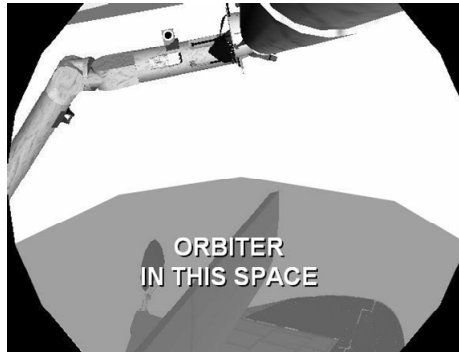

Note clearance thru LDRI FOV

Return PTU to Pan and Tilt values recorded above

VID OUT MUX 1 L pb – push (MIDDECK It on)
LDRI MODE 6 pb – push (flickering LDRI video)

VID OUT MON 1 pb – push
IN pb – as desired (not PL2)

L10(VTR) REC pb – push, hold
PLAY pb – push, simo (red dot)

A8U AUTO SEQ – PROCEED (IN PROG It on)

LDRI PAN/TILT RESET

Reset PTU

A7 VID OUT MON 1 pb – push
IN PL2(VPU) pb – push

CAMR CMD PAN/TILT – HI RATE
PAN – L (to hard stop)
TILT – UP (to hard stop)
PAN/TILT – RESET

SPEE PWR DEACT CLEANUP ACTIONS

Config RSC Illum to HI

R12 (OBSS) √SPEE PWR – OFF
ITVC ENA – OFF
RSC PWR – OFF, wait 10 sec, ON
SPEE PWR – ON, OFF, wait 10 sec, ON

Config ITVC

ITVC ENA – ON
A7 VID OUT DTV pb – push
IN PL2(VPU) pb – push
If MAN GAIN pb not illuminated:
R12 (OBSS) ITVC ENA – OFF, wait 10 sec, ON
Repeat until MAN GAIN pb illuminated
A7 LT LEVEL pb – push
DAY (NIGHT) pb – push
ALC pb – push
AVG pb – push

Reset PTU

A7 CAMR CMD PAN/TILT – HI RATE
PAN – L (to hard stop)
TILT – UP (to hard stop)
PAN/TILT – RESET
PAN and TILT ITVC to values needed for
Survey

Return LDRI to Mode 6

A7 VID OUT MUX 1 L pb – push
IN MIDDECK pb – push
LDRI MODE 6 pb – push
VID OUT DTV pb – push, to return to ITVC
control

P/TV-7b/131/O/A

(reduced copy)

FS CC 3-15

P/TV/131/FIN

HOOK
VELCRO

LCH ACTIVATION

- A15 Activate SSPTS APCU 2
 √PTU 2 fb – on
 APCU 2 OUTPUT – ON
 CONV – ON
- SM 179 POWER TRANSFER
 √PTU 2 APCU OUT VOLTS: 123V to 126V
 √OUTPUT – ON

LCC ACTIVATION

1. LCC Setup
 √Hardware and cables configured per diagram below:

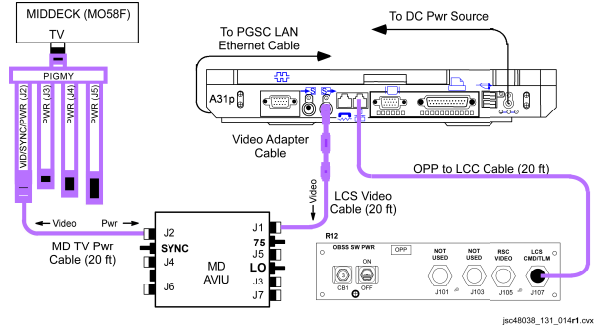

2. LCC Startup
 A31p √PGSC Pwr – ON
 √Yellow 'RJ-45 Port Configured for LCS Ops' displayed on desktop crew patch
 If yellow text not displayed, perform TROUBLESHOOTING, Yellow 'RJ-45 Port Configured for LCS Ops' Not Displayed on Desktop Crew Patch
 If 'LCS Camera Controller' minimized on desktop taskbar, maximize window
 If not minimized, sel 'Shuttle Apps' > 'LCC' (wait 2-3 min from APCU CONV – ON for GUI Status)
 √Laser off – blue
 √Comm – green
 If Laser off and Comm status not correct: √MCC
3. Verify LCC Desktop Video
 MO58F √TV PWR – ON
 AVIU √HI-Z/75 – 75
 PWR SELECT – LO
 CC PWR – OFF

(For SSPTS APCU 2 flights only)

TOP

LCS

HOOK
VELCRO

3. Verify LCC Desktop Video (Concluded)
 A31p Minimize all programs
 Right click on ATI icon on system tray
 Sel 'Schemes'
 Sel 'ENABLE DESKTOP DOWNLINK', 'ATI Property Page' displayed
 Sel 'Yes'
 Maximize program windows as desired
- A7 VID OUT MON1(2) pb – push
 IN MIDDECK pb – push
- A3 √LCC desktop displayed on MON1(2)
 * If LCC Desktop not displayed *
 * √MCC *
 *
4. Verify GMT
 A31p √GMT on GUI lower right-hand side within 3 sec of SM-GPC GMT
 * If GMT not within 3 sec of SM GPC: *
 * Sel 'Tools' > 'Set GMT' *
 * Adjust GMT as reqd *
 * Sel 'Apply' > 'OK' *

OPERATION

NOTE
 PDRS OPS will call for appropriate scan steps on LCC.
 MCC may have limited insight if desktop dnk avail

1. Load Database (if reqd)
 √MCC for desired LCS database
 √'DB Name': Field on upper left-hand side of LCS GUI
 * If 'DB Name' incorrect: *
 * Sel 'Load Database...' from File menu *
 * Sel MCC desired database file *
 * Sel 'OK' *
2. LCS System Status

LCS SYSTEM STATUS

Laser On/Off	Comm	LCS State
Laser ? (gray)	No Comm (yellow)	Unknown or Keep Alive Heater Only Mode (No LCC to LCH Network Connection)
Laser Off (blue)	Comm (green)	Configuration (Waiting for user command)
Laser On (green)	Comm (green)	Operational (Scan in progress)

While Scan in progress ('Scan Status' counter incrementing):
 √Laser On – green
 √Comm – green
 √Scan Display – updating
 √Temp – green
 √Elec – green
 Scan complete when 'Scan Status: Complete' displayed
 If LCS system status out of config, perform appropriate TROUBLESHOOTING section of this cue card

P/TV-8a/131/O/A

(reduced copy)

FS CC 3-16

P/TV/131/FIN

HOOK
VELCRO

HOOK
VELCRO

LCC DEACTIVATION

NOTE

Shutting down LCC software also puts LCH in keep-alive heater mode. No LCH scans/insight or IDC ops available. APCU Converter pwr cycle reqd to reinitialize LCH for scanning and IDC ops

1. LCC Software Shutdown

- A31p Sel 'File' > 'Exit'
- When 'Shutdown' dialog box opens:
 - √Shutdown LCH and Exit LCC Software' selected
 - Sel 'OK'
- When 'Shutdown?' dialog box opens:
 - Sel 'OK'

2. A31p Screen Resolution Reset

- A31p Right click on ATI icon on system tray
- Sel 'Schemes'
- Sel 'DISABLE DESKTOP DOWNLINK, ATI Property Settings'
- Sel 'Yes'
- Arrange program windows as desired

LCH DEACTIVATION

CAUTION

Deactivating SSPTS APCU 2 will remove critical keep-alive pwr to LCH and IDC. Pwr must be reapplied within 105 min

1. Deactivate SSPTS APCU 2/LCH

- A15 APCU 2 CONV – OFF
- SM 179 POWER TRANSFER
- √PTU 2 APCU OUT VOLTS: <10V
- APCU 2 OUTPUT – OFF

TROUBLESHOOTING

Temp or Elec Status Yellow

- A31p Sel 'System' page
- Report 'Elec' or 'Temp' values backlit in yellow to MCC

Comm Status Yellow and LAN2 Network cable unplugged (red X on A31p system tray)

NOTE

LCC GUI Comm status will be yellow and A31p Local Area Network status (w/red X on A31p system tray) cable unplugged tool tip will appear if LCH is in keep-alive heater mode

- A31p If unexpected red X w/Local Area Network Connection tool tip shown on A31p system tray:



- R12 √OPP to LCC Cable connected to LCS CMD/TLM(J107) port
- A31p √OPP to LCC Cable connected to LCC RJ45 port
- Exit LCC software and shut down Windows

- A15 APCU 2 CONV – OFF
- OUTPUT – OFF, wait 10 sec, ON
- CONV – ON

SM 179 POWER TRANSFER

- √PTU 2 APCU OUT VOLTS: 123V to 126V

- A31p LCC PGSC Pwr – ON
- √A31p internal RJ45 Network Interface Card LED green
- Perform LCC ACTIVATION, step 2

- √Local Area Network Connection status icon (with red X) in Windows system tray not displayed
- √MCC if LCC GUI Comm status still yellow

Message Area Entry

- Report LCC GUI message area log entry(ies) to MCC

Yellow 'RJ-45 Port Configured for LCS Ops' Not Displayed on Desktop Crew Patch

- A31p Sel 'Shuttle Apps' > 'Network Configuration' > 'LCS RJ-45 Network Setup'
- Enter '1' in network window
- Sel 'OK'
- Sel 'OK' in LCS window
- Allow 20 sec for program to execute
- √Yellow text displayed on desktop
- Resume LCS Ops

(For SSPTS APCU 2 flights only)

(reduced copy)

HOOK
VELCRO

TOP

IDC

HOOK
VELCRO

IDC ACTIVATION

- LCC Setup
A31p √Hardware configured per LCC ACTIVATION steps 1,2 (Cue Card, LCS)
A31p √PGSC Pwr – ON
- IDC connectivity Check
A31p √A31p internal RJ45 Network Interface Card LED green

A15 If RJ45 Network Interface Card LED not green:
 APCU 2 CONV – OFF
 OUTPUT – OFF, wait 10 sec, ON
 CONV – ON

 SM 179 POWER TRANSFER
 √PTU 2 APCU OUT VOLTS: 123V to 126V

IDC SOFTWARE ACTIVATION

- IDC Software Startup
A31p Sel 'Shuttle Apps' > 'IDC'
- Verify GMT
A31p √GMT within 3 sec of SM-GPC GMT

 * If GMT not within 3 sec: *
 * Double click on GMT box on GUI *
 * Adjust GMT as reqd *
 * Sel 'OK' on MTU Time dialogue box *
- IDC Pwr on and self test

CAUTION
Pwr off IDC when not imaging. Pointing IDC at Sun when pwr on will damage Camr

- A31p Sel 'Power On'
- √Black and White self-test image displayed
 √'Waiting for User Command' displayed
- * If red backlit error msg displayed: *
 * Perform appropriate TROUBLESHOOTING *
 * steps on this cue card *

OPERATION

NOTE

PDRS OPS will call for IDC image steps on LCC A31p. Limited MCC real-time insight avail if configured for desktop dnk

- Configure LDRI Illumination
R12 (VPU) √Green Jumper – LDRI/ITVC
A7 VID OUT MUX 1L pb – push
 IN MIDDECK pb – push
 LDRI MODE 2 pb – push
 VID OUT MON 1(2) pb – push
 IN PL2 (VPU) pb – push
 CAMR CMD PAN/TILT – HI RATE
 PAN – L (to hard stop)
 TILT – UP (to hard stop)
 PAN/TILT – RESET
 – LO RATE within 10°
 PAN: +85 (right)
 TILT: -57 (down)

NOTE

If IDC GUI GMT does not update during Ops, an attempt to shut down/restart A31p should be made

- Auto Exposure (AE) Ops
A31p √'Use AE' checked
 Sel 'Scan Lo-Res'
 Resize and posn AE box as reqd (pause 2 sec)
 √MCC for AOI FOV
 Sel 'Scan Hi-Res'
 If Scanning w/no RMS Motion:
 | Sel 'Stop Scan' after 30 sec
 If scanning w/RMS motion:
 Move box to maintain RCC in AE box (using keyboard arrows)
 Sel 'Stop Scan' at pause point
 √'Waiting for User Command' displayed
- Scenario File Ops
A31p From Scenario File drop-list, sel appropriate lighting condition

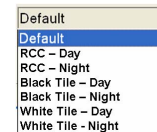

- Sel 'Acquire Set'
 √'Acquiring Set' displayed
 √'Waiting for User Command' displayed after set
 √MCC content w/data take

P/TV-9a/131/O/B

(For SSPTS APCU 2 flights only)

(reduced copy)

FS CC 3-18

P/TV/131/FIN 2

HOOK
VELCRO

HOOK
VELCRO

IDC DEACTIVATION

- IDC and Software Shutdown
A31p Sel 'Power off' on IDC GUI
IDC software > 'YES'
Close (X) IDC software > 'YES'
- A31p Screen Resolution Reset
A31p Right click on ATI icon on system tray
Sel 'Schemes'
Sel 'DISABLE DESKTOP DOWNLINK, ATI Property Settings'
Sel 'Yes'
Arrange program windows as desired

IDC HOT KEY COMMANDS

- | | |
|------------------------------------|-------------------------------|
| F5 – Toggle Summary View | F6 – Toggle Image Mode |
| F7 – Zoom In | F8 – Zoom Out |
| F9 – Reset Brightness and Contrast | F10 – Reset AE Box to Default |
| F11 – Toggle AE Box Visibility | F12 – Find AE Box |

IDC SOFTWARE ERROR MESSAGES

- Can't connect to LCH:** Perform TROUBLESHOOTING, steps 1,2
Condition: Possible heater only mode or Network failure
- Iport probe failed:** Perform TROUBLESHOOTING, step 2
Condition: Iport startup check failed
- Iport not responding:** Perform TROUBLESHOOTING, step 2
Condition: Iport connection lost
- Camera not responding:** Perform TROUBLESHOOTING, step 2
Condition: Camera connectivity lost
- Image acquisition failed:** Perform TROUBLESHOOTING, steps 1,2
Condition: Camera connectivity lost during imaging
- Network recovery failed:** Perform TROUBLESHOOTING, steps 1,2
Condition: LCH network switch connection lost
- Bad initialization file:** Perform TROUBLESHOOTING, step 3
Condition: Software will not launch due to severe ini file corruption

TROUBLESHOOTING

- LCC to LCH Connectivity Check
A31p If Local Area Network Connection (with red X) tool tip on system tray:



Reseat OPP to LCC Cable (20 ft) to LCC RJ45 port
√Local Area Network Connection Speed 10 mps
If no connection:
Perform LCH, LCC, and IDC Reset, step 2
Continue nominal ops

- LCH, LCC, and IDC Reset
A31p Exit IDC software and shut down Windows
√OPP to LCC Cable (20 ft) connected to LCC RJ45 port and LCS
CMD/TLM port
- A15 APCU 2 CONV – OFF
OUTPUT – OFF, wait 10 sec, ON
CONV – ON

SM 179 POWER TRANSFER
√PTU 2 APCU OUT VOLTS: 123V to 126V
- A31p LCC PGSC Pwr – ON
√A31p internal RJ45 Network Interface Card LED green

Perform IDC SOFTWARE ACTIVATION
Continue nominal ops
- LCC Swap
A31p Exit IDC software and shut down Windows
Swap LCC with other A31p
Perform IDC Activation
Perform IDC Software Activation
Continue nominal ops

(For SSPTS APCU 2 flights only)

(reduced copy)

FS CC 3-19

P/TV-9b/131/O/A

P/TV/131/FIN

TOP

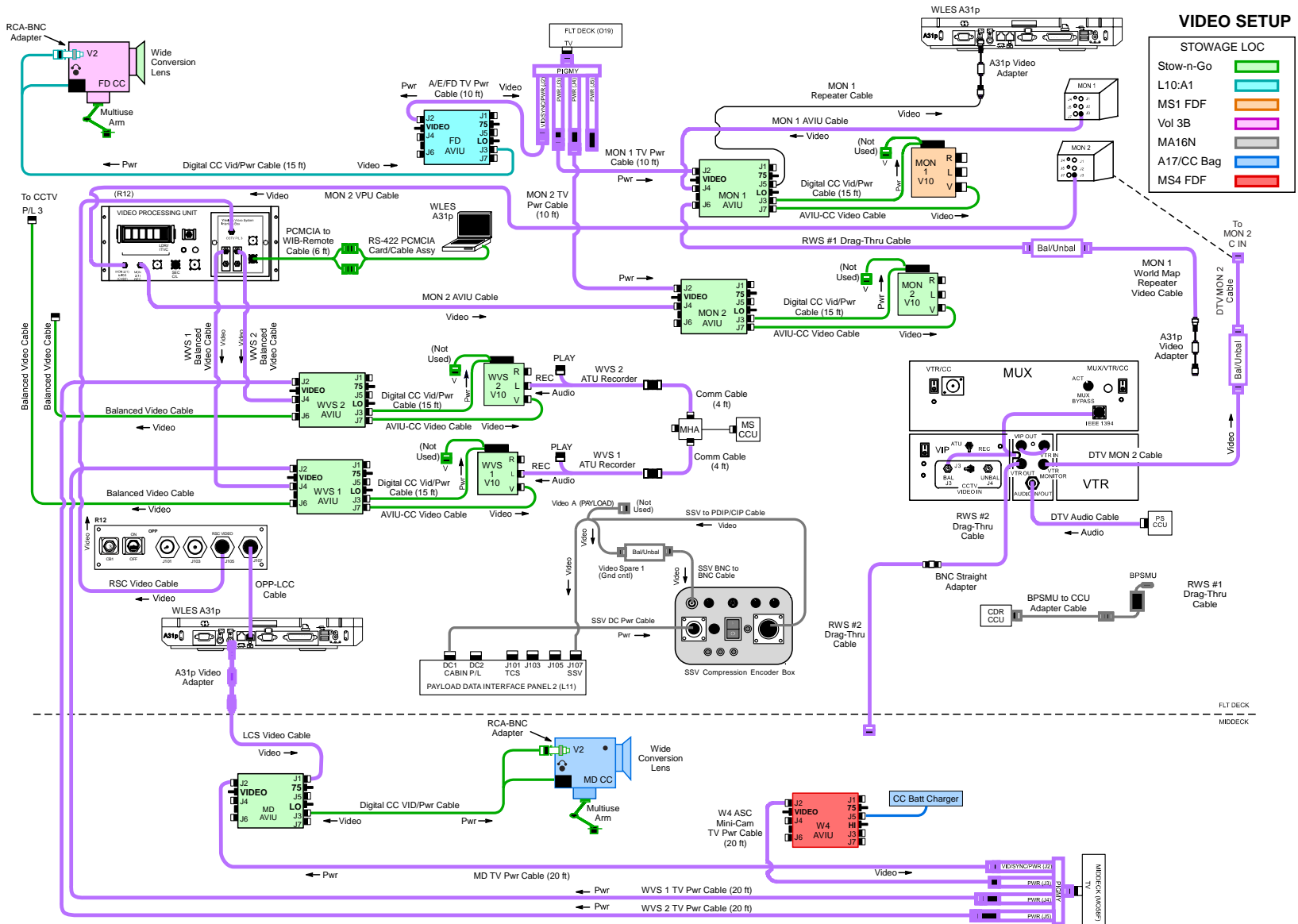

VIDEO SETUP

STOWAGE LOC

- Stow-n-Go █
- L10:A1 █
- MS1 FDF █
- Vol 3B █
- MA16N █
- A17/CC Bag █
- MS4 FDF █

(reduced copy)
FS CC 3-20

jsc48038_131_001ccr4.vcx

P/TV-10a/131/O/C

P/TV/131/FIN 3

TOP
BACK OF 'VIDEO SETUP'

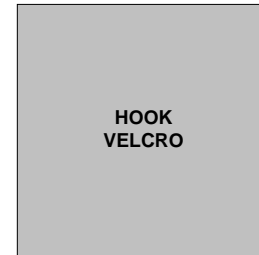
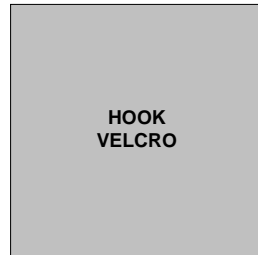
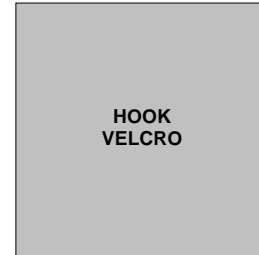
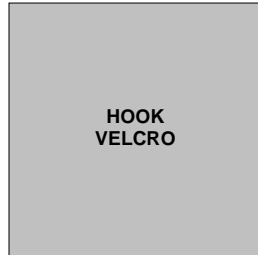

(reduced copy)
FS CC 3-21

P/TV-10b/131/O/A















P/TV/131/FIN

TOP













D2Xs SETUP

HOOK
VELCRO

D2Xs PROGRAM In Cabin	D2Xs Aperture Priority	D2Xs Shutter Priority "Earth Obs"
<p>Lens – as reqd Aperture – Min, locked Body Focus Mode – S √Batt installed √Flash Card installed Pwr – ON Top LCD: √Batt √Frames remaining sufficient Exp Comp () – 0.0 Exp Mode – P Meter – Matrix () Diopter – Adjust Frame Rate – S √BKT disabled – 0 F Rear LCD: √ISO – 100 √QUAL – RAW √WB – 0,A AF Area Mode – [[]] √Focus Area – Center √Focus Selector Lock – L</p> <p>SB-800 Flash Settings: √Diffuser Dome installed ON/OFF pb – ON √MODE –    √Exp Comp – 0 EV Tilt – 45° (Direct)</p>	<p>Lens – as reqd Aperture – Min, locked Body Focus Mode – S √Batt installed √Flash Card installed Pwr – ON Top LCD: √Batt √Frames remaining sufficient Exp Comp () – 0.0 Exp Mode – A: f/stop – as reqd Meter – Matrix () Diopter – Adjust Frame Rate – S √BKT disabled – 0 F Rear LCD: √ISO – 100 √QUAL – RAW √WB – 0,A AF Area Mode – [[]] √Focus Area – Center √Focus Selector Lock – L</p> <p>SB-800 Flash Settings: √Diffuser Dome installed ON/OFF pb – ON √MODE –    √Exp Comp – 0 EV Tilt – 45° (Direct)</p>	<p>SB-800 Flash Settings: ON/OFF pb – OFF</p> <p>Lens – as reqd Aperture – Min, locked Body Focus Mode – S √Batt installed √Flash Card installed Pwr – ON Top LCD: √Batt √Frames remaining sufficient Exp Comp () – 0.0 Exp Mode – S: SS – 500 Meter – Matrix () Diopter – Adjust Frame Rate – S √BKT disabled – 0 F Rear LCD: √ISO – 100 √QUAL – RAW √WB – 0,A AF Area Mode – [[]] √Focus Area – Center √Focus Selector Lock – L</p>

TOP
BACK OF 'D2Xs'

HOOK
VELCRO

D2Xs MANUAL "SUNLIT OBJECTS"	D2Xs EXPOSURE MATCH "HERO SHOT"	D2Xs CREW PHOTO
<p>SB-800 Flash Settings: ON/OFF pb – OFF</p> <p>Lens – as reqd</p> <p>NOTE If auto focus unachievable: Lens Focus Mode – M</p> <p>Lens Focus Mode – A Aperture – Min, locked Body Focus Mode – S √Batt installed √Flash Card installed Pwr – ON Top LCD: √Batt √Frames remaining sufficient</p> <p>Exp Comp () – 0.0</p> <p>Exp Mode – M: SS – 500 f/stop – f/8</p> <p>Meter – Matrix () Diopter – Adjust Frame Rate – S √BKT disabled – 0 F</p> <p>Rear LCD: √ISO – 100 √QUAL – RAW √WB – 0,A</p> <p>AF Area Mode – [[]] √Focus Area – Center √Focus Selector Lock – L</p>	<p>Lens – 12-24mm @ 18mm Aperture – Min, locked Body Focus Mode – S √Batt installed √Flash Card installed Pwr – ON Top LCD: √Batt √Frames remaining sufficient</p> <p>Exp Comp () – 0.0 Exp Mode – P Meter – Matrix () Diopter – Adjust Frame Rate – S √BKT disabled – 0 F</p> <p>Rear LCD: √ISO – 100 √QUAL – RAW √WB – 0,A</p> <p>AF Area Mode – [[]] √Focus Area – Center √Focus Selector Lock – L</p> <p>SB-800 Flash Settings: √Diffuser Dome installed ON/OFF pb – ON</p> <p>√MODE –   </p> <p>√Exp Comp – 0 EV Tilt – 45° (Direct)</p> <p>Technique</p> <ol style="list-style-type: none"> 1. Fill FOV w/sunlit subject 2. Activate D2Xs Cam 3. Auto Exp Lock – Depress,hold Expect values such as 250,f/11 4. Focus, Frame, Fire 	<p>Lens – 17-35mm @ 17mm Aperture – Min, locked Body Focus Mode – S √Batt installed √Flash Card installed Pwr – ON Top LCD: √Batt √Frames remaining sufficient</p> <p>Exp Comp () – 0.0</p> <p>Exp Mode – A: f/stop – f/8</p> <p>Meter – Matrix () Diopter – Adjust Frame Rate – Selftimer</p> <p>√BKT disabled – 0 F</p> <p>Rear LCD: √ISO – 100 √QUAL – RAW √WB – 0,A</p> <p>AF Area Mode – [[]] √Focus Area – Center √Focus Selector Lock – L</p> <p>SB-800 Flash Settings: √Diffuser Dome installed ON/OFF pb – ON</p> <p>√MODE –   </p> <p>√Exp Comp – 0 EV Tilt – 45° (Direct)</p> <p>Accessory Equipment: Shutter Release Cable – Install Multiuse Brkt – Install Multiuse Brkt Clamp – Install as reqd</p> <p>Technique</p> <ol style="list-style-type: none"> 1. Focus on crewmember 2. Body Focus Mode – M 3. Frame, Fire

P/TV-11b/131/O/B

(reduced copy)

FS CC 3-23

P/TV/131/FIN

TOP

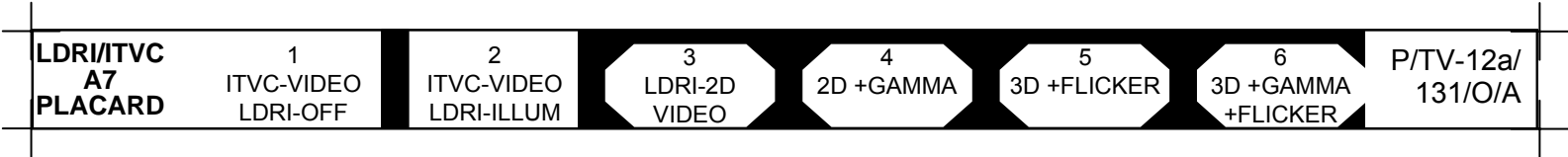

TOP
BACK OF 'LDRI/ITVC A7 PLACARD'

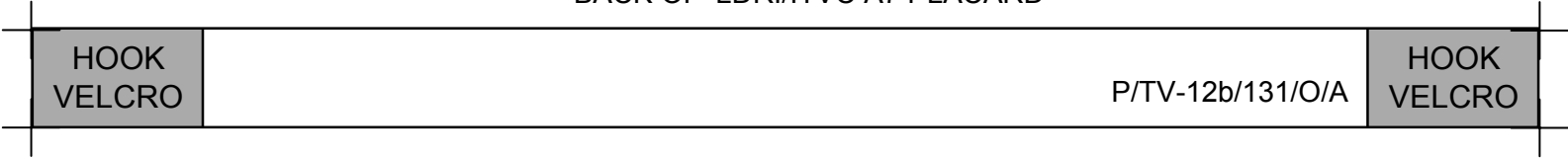

DIGITAL PLAYBACKHOOK
VELCRO**HD DIGITAL VIA CC****DIGITAL VIA VTR**NOTE

Digital Playback from CC only possible for CC Video recordings

ACTIVATION

CC Setup per diagram (back of cue card)
For cable strain relief, attach MPC-to-G1 Cable
Velcro strap to CC strap

AVIU SYNC/VIDEO – VIDEO
HI-Z/75 – 75
PWR SELECT – LO

O19 √TV PWR – ON

CC PWR dial – VCR/PLAY

If Dnlk
Notify MCC, configuring for HD TV dnlk

L10 (MUX) √MUX/VTR/CC PWR – on (LED on)
√MUX BYPASS – ACT
√CH 0,1 RATE SEL – 1
√2 RATE SEL – 8
(VTR) ON/STANDBY pb – push (LED red)
(VIP) PWR – off (LED off)

O19 DC UTIL PWR MNA – ON

MPC PWR SPLY DC PWR SPLY PWR SW1 – ON

MPC PWR – ON (5V,3V green LEDs on)

L10 (MUX) √CH 2 F/O OK LED on

OPERATIONSPLBK or DNLK VIDEO

CC Install tape, if reqd
VTR pb – REW(FF),PLAY,PAUSE to cue tape

If Dnlk
MPC √HDV, TAXI LEDs – on
L10 (MUX) √CH 2 DATA LED – on

CC PLAY pb – push (green ► displayed)
If PLBK(DNLK) complete:
| STOP pb – push
If CC ops complete, go to DEACTIVATION

DEACTIVATION

CC Remove, mark, stow tape as reqd
PWR dial – OFF

O19 TV PWR – OFF, as reqd

If Dnlk
MPC PWR – OFF

MPC PWR SPLY DC PWR SPLY PWR SW1 – OFF

O19 DC UTIL PWR MNA – OFF

L10 (MUX) √VTR/CC PWR – on (LED on)
MUX/VTR/CC PWR – off (LED off)
(VIP) PWR – on (LED on, DATA FLOW LED flashes
twice)
(VTR) ON/STANDBY pb – push (LED green)

Notify MCC, returned to SD TV dnlk
Go to DEACTIVATION (Cue Card, TV), as reqd

ACTIVATION

Setup per diagram (back of cue card)

L10 (MUX) √VTR/CC PWR – on (LED on)
(VTR) √ON/STANDBY LED – green

OPERATIONSPLBK or DNLK VIDEO

L10 (VTR) Install tape if reqd
√CHARACTER DISPLAY (LCD) – ON
√DISPLAY SELECT – DATA

Remote If Index Search reqd:
√ID – VTR4
SEARCH MODE pb – push (INDEX
SEARCH mode displayed)
| ◀▶ (▶▶) pb – push to move highlight
bar to desired GMT start
When VTR auto-cue complete, green •
displayed:
PAUSE pb – push
If playback time not displayed on DSR-25 LCD
cycle "DATA CODE" repeatedly until time
displayed

L10 (VTR) REW(FF),PLAY,PAUSE pb – push as reqd to
cue tape

If Dnlk
L10 (MUX) MUX/VTR/CC PWR – on (LED on)
√MUX BYPASS – ACT
√CH 3 DATA LED – on

L10 (VTR) PLAY pb – push (green • displayed)

If PLBK(DNLK) complete:
| STOP pb – push
If VTR ops complete, go to DEACTIVATION

DEACTIVATION

L10 (VTR) Remove, mark, stow tape as reqd
Go to DEACTIVATION (Cue Card, TV), as reqd

TOP
BACK OF 'DIGITAL PLAYBACK'

HOOK
VELCRO

HD DIGITAL VIA CC PLAYBACK

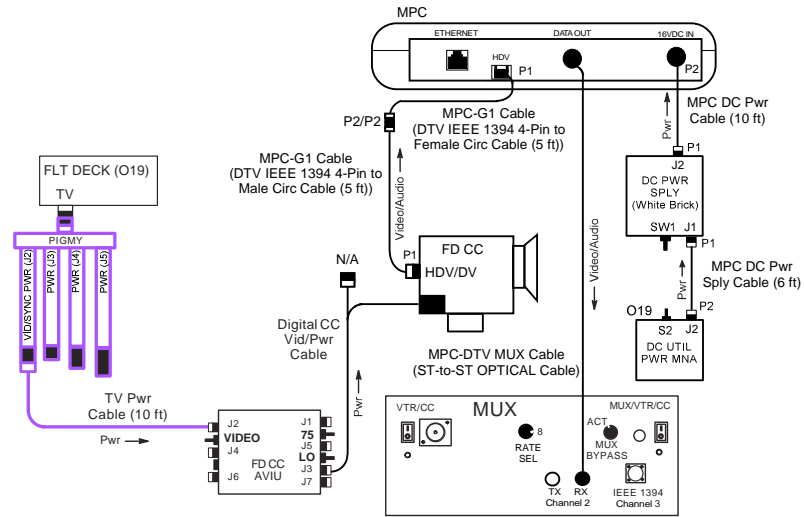

jsc48038_131_012e.cvx

DIGITAL VIA VTR PLAYBACK

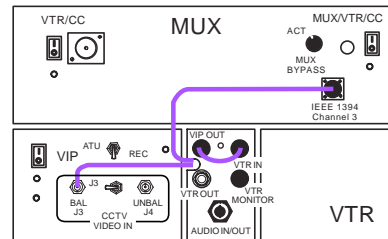

jsc48038_131_012d.cvx

P/TV-13b/131/O/A

(reduced copy)
FS CC 3-26

P/TV/131/FIN

TOP

G1 CC SETUP CUE CARD

HOOK
VELCRO

ASSUMPTION: G1 is powered by either direct or battery power

WELL LIT SCENE ("green" <input type="checkbox"/>)	SUN-LIT SCENE (M)	DIM-LIT SCENE (A)
<p>Install Wide Conversion Lens as reqd ND FILTER – OFF (per CC prompt) √OUTPUT – CAM √A/V1/V2 – V2 √<input type="checkbox"/>..<input type="checkbox"/><input type="checkbox"/>-<input type="checkbox"/><input type="checkbox"/> √STANDBY/LOCK – STANDBY PWR dial – "green" <input type="checkbox"/> Open LCD √Tape installed</p>	<p>Install Wide Conversion Lens as reqd √ND FILTER – OFF AF/M – AF(M) AGC – OFF GAIN – L √OUTPUT – CAM √AWB – ON √AUDIO LEVEL – A √A/V1/V2 – V2 √<input type="checkbox"/>..<input type="checkbox"/><input type="checkbox"/>-<input type="checkbox"/><input type="checkbox"/> √STANDBY/LOCK – STANDBY PWR dial – M Open LCD √Tape installed √GAIN – 0dB SS – 1/500 (Small Wheel) f/stop – F8.0 (Aft Ring) Adjust focus if AF/M – M (Fwd Ring)</p>	<p>Install Wide Conversion Lens as reqd √ND FILTER – OFF AF/M – AF AGC – OFF √OUTPUT – CAM √AWB – ON √AUDIO LEVEL – A √A/V1/V2 – V2 √<input type="checkbox"/>..<input type="checkbox"/><input type="checkbox"/>-<input type="checkbox"/><input type="checkbox"/> √STANDBY/LOCK – STANDBY PWR dial – A Open LCD √Tape installed √GAIN – L (M,H) per Scene</p>

P/TV-17a/131/O/A

(reduced copy)

FS CC 3-27

P/TV/131/FIN

TOP
BACK OF 'G1 CC SETUP CUE CARD'

HOOK
VELCRO



(reduced copy)
FS CC 3-28

P/TV-17b/131/O/A



P/TV/131/FIN

NOTE

Replace this page with four (4) sheets of blue
K-10 stock in crew copies only

NOTE

Replace this page with four (4) sheets of blue
K-10 stock in crew copies only



**PHOTO/TV
CHECKLIST**

**STS
131**