

(NASA-CR-180425) THE DEVELOPMENT PROCESS  
FOR THE SPACE SHUTTLE PRIMARY AVIONICS  
SOFTWARE SYSTEM (IBM Federal Systems Div.)  
87 p Avail: NTIS HC A05/MF A01 CSCL 01D

N87-29530

Unclas  
G3/06 0098640

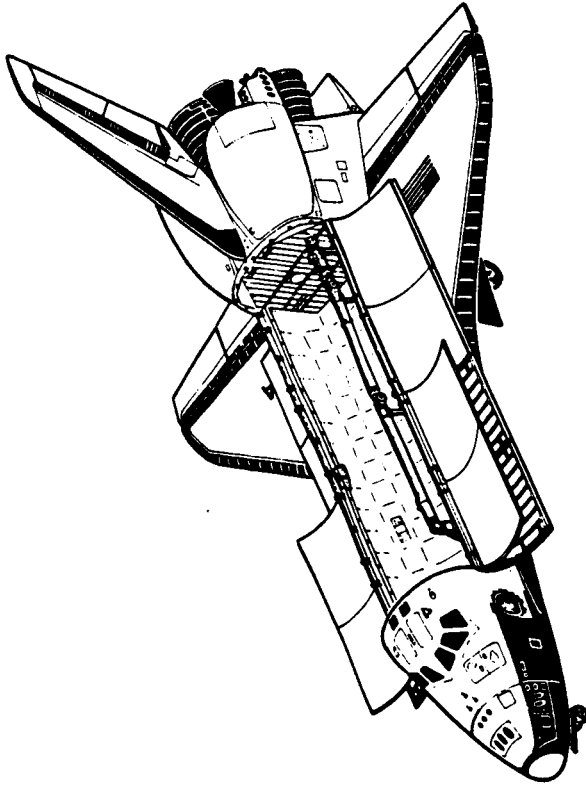

THE  
DEVELOPMENT PROCESS FOR THE  
SPACE SHUTTLE  
PRIMARY AVIONICS SOFTWARE SYSTEM

# SPACE SHUTTLE PROGRAMS



Federal Systems Division  
3700 Bay Area Boulevard  
Houston, Texas 77058/1199

PRESENTATION TO COMMON CONFERENCE

OCTOBER 20, 1987  
CHICAGO, ILLINOIS

T. W. KELLER  
MANAGER, OBS PROJECT COORDINATION &  
CONFIGURATION MANAGEMENT

SOFTWARE CRITICAL TO NASA SHUTTLE

---

---

CONTENTS

0	INTRODUCTION
0	PROJECT OVERVIEW
0	PRIMARY AVIONICS SOFTWARE SYSTEM DESCRIPTION
0	SOFTWARE DEVELOPMENT APPROACH
0	USER SUPPORT AND PROBLEM DIAGNOSIS
0	SOFTWARE RELEASES AND RECONFIGURATION
0	APPENDICES
	A. QUALITY/PRODUCTIVITY PROGRAMS
	B. SOFTWARE DEVELOPMENT/PRODUCTION FACILITIES
	C. ACRONYMS
	D. EXTERNAL EVALUATIONS OF IBM PROCESS

## INTRODUCTION

# IBM CORPORATE ORGANIZATION

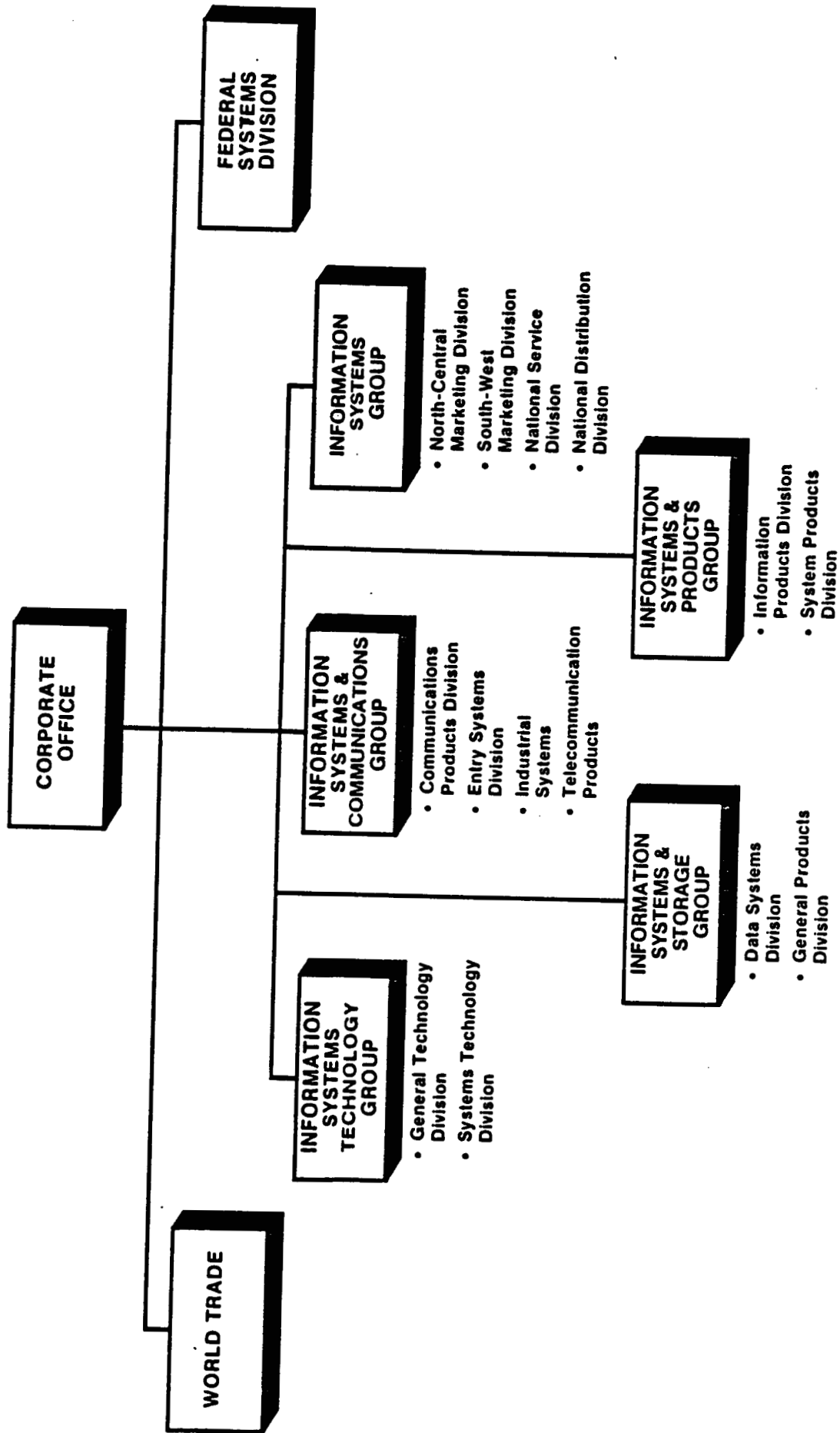

IBM FSD HOUSTON

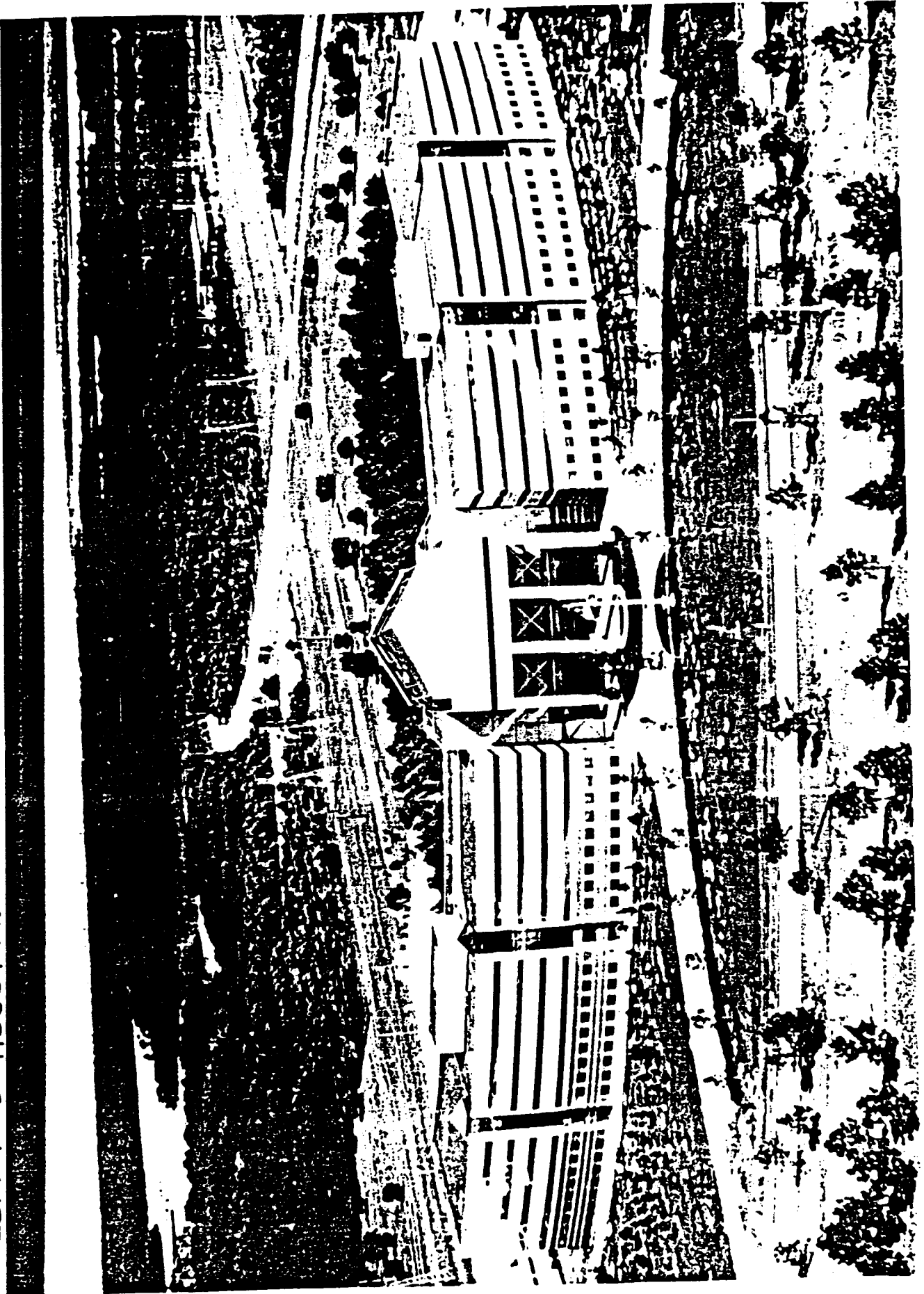

ORIGINAL PAGE IS  
OF POOR QUALITY

# **PROJECT OVERVIEW**

# **SOFTWARE CRITICAL TO NASA SHUTTLE**

## **PROJECT OVERVIEW**

- **Software Development Spanned Over 10 Years to the Base System Delivery in 1981**
- **Now Incorporating New Capabilities Into the Base System**
- **Current Level of 300 - 350 Software Developers Per Year**
- **Releases Tailored to Specific Missions by Data Reconfiguration**
- **All Work Done in the NASA Software Development and Production Facilities**
- **On-Line Access to Software Via Terminals**

# **SOFTWARE CRITICAL TO NASA SHUTTLE**

## **SOFTWARE DEVELOPMENT PHILOSOPHY**

- **Goals:**
  - **Meet Letter and Intent of Customer Requirements**
  - **Perform in Accordance with Customer Expectations**
  - **Error-Free Software**
- **Project Organization Functions**
  - **Requirements Analysis, System Architecture**
  - **Software Development (Design, Code, Test)**
  - **System Build and Integration**
  - **Independent Verification**
  - **Reconfiguration/Certification**
  - **Customer and Field Support**
- **Configuration Management**
  - **Formal Board Structure**
  - **Documents Requirements and Design Baselines**
  - **Stored in Configuration Management Data Base**



# IBM DEVELOPED SOFTWARE — SPACE TRANSPORTATION SYSTEM

SOFTWARE PROJECT	SOURCE LINES OF CODE (X 1000)	NASA CENTER
FLIGHT SOFTWARE SYSTEM	500K	JSC
SOFTWARE PRODUCTION FACILITY (SPF) (SIMULATOR AND SUPPORT SOFTWARE)	1,700K	JSC
MISSION AND PAYLOAD CONTROL CENTERS	4,000K	JSC
LAUNCH PROCESSING SYSTEM	2,500K	KSC
SPACELAB	800K	MSFC
TOTAL	9,500K	

# **PRIMARY AVIONICS SOFTWARE SYSTEM DESCRIPTION**

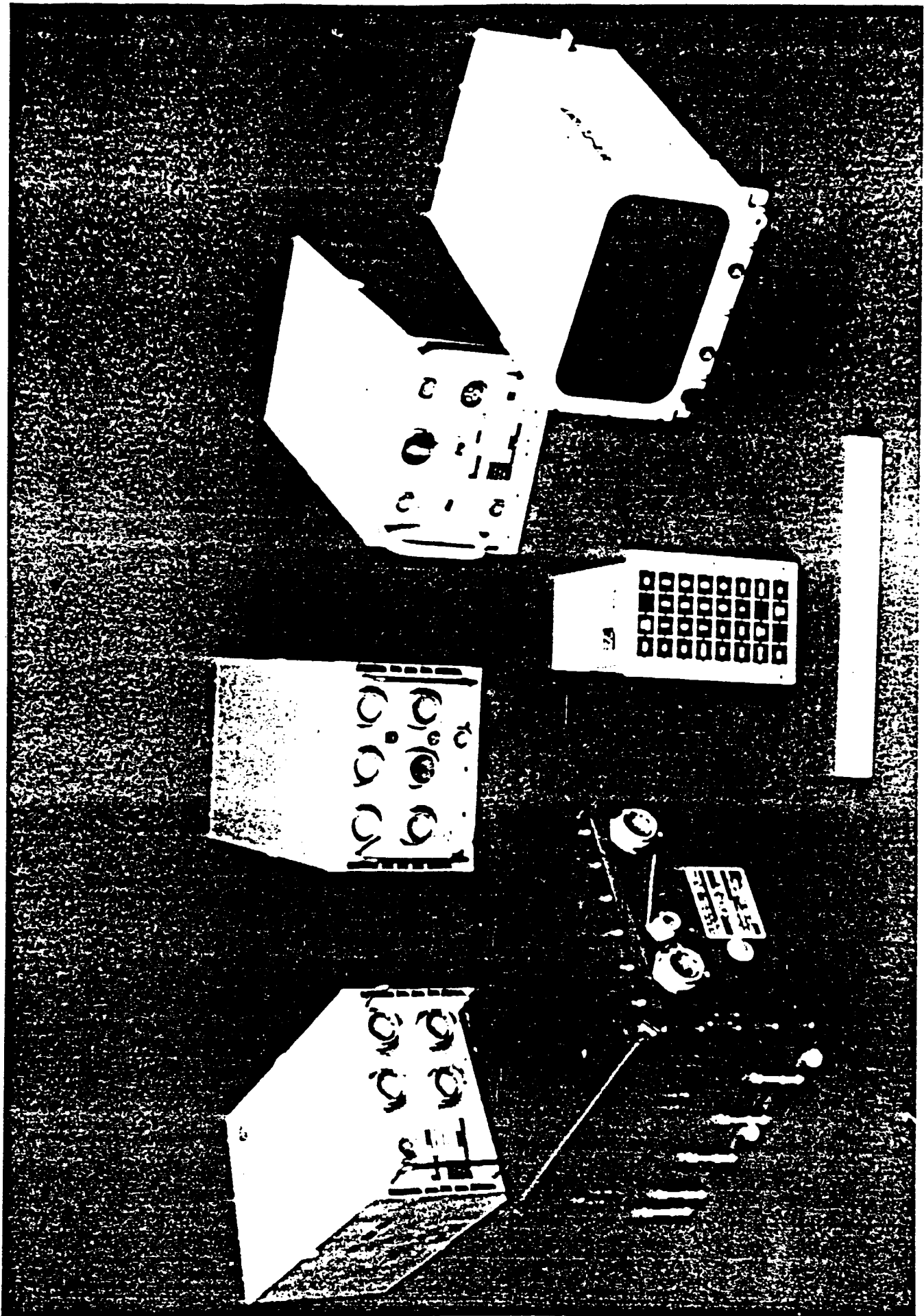

ORIGINAL PAGE IS  
OF POOR QUALITY

# SHUTTLE ONBOARD DATA PROCESSING SYSTEM

- **HARDWARE**
  - 5 GENERAL PURPOSE FLIGHT COMPUTERS (GPC's)
  - WITH ASSOCIATED DISPLAYS, KEYBOARDS AND MASS STORAGE DEVICES
- **SOFTWARE**
  - PRIMARY AVIONICS SOFTWARE SYSTEM (PASS)
  - SEPARATED INTO 7 OPERATIONAL PROGRAMS
  - KEYED TO SPECIFIC MISSION PHASES
  - BACKUP FLIGHT SYSTEM (BFS)
    - PROVIDES ADDITIONAL REDUNDANCY DURING CRITICAL FLIGHT PHASES
    - EXECUTES ONLY DURING ASCENT AND ENTRY
- **DURING CRITICAL MISSION PHASES (ASCENT, ENTRY, PRE-FLIGHT PREP.)**
  - 4 OF 5 GPC's CONTAIN THE PRIMARY AVIONICS SOFTWARE EXECUTING REDUNDANTLY
  - THE 5TH COMPUTER CONTAINS THE BACKUP FLIGHT SYSTEM EXECUTING IN PARALLEL (WITH OUTPUT COMMANDS INHIBITED)
- **IN LESS-CRITICAL MISSION PHASES (ON-ORBIT)**
  - MULTIPLE PASS OPERATIONAL PROGRAMS EXECUTE IN 2 OR 3 GPC's
  - REMAINING GPC's ARE POWERED-OFF

## REDUNDANT GPC SETS

- Processes within GPCs synchronized.
- Identical input data required. Listen mode used to allow GPC to receive data from bus not under its control.
- Sync points inserted at appropriate locations in software.(~350/sec.).
- Dedicated sync lines interconnect all GPCs. All must send and receive sync discretes at sync window.
- Allows independent strings with simultaneous data access.

# EXAMPLE OF REDUNDANT PROCESSING

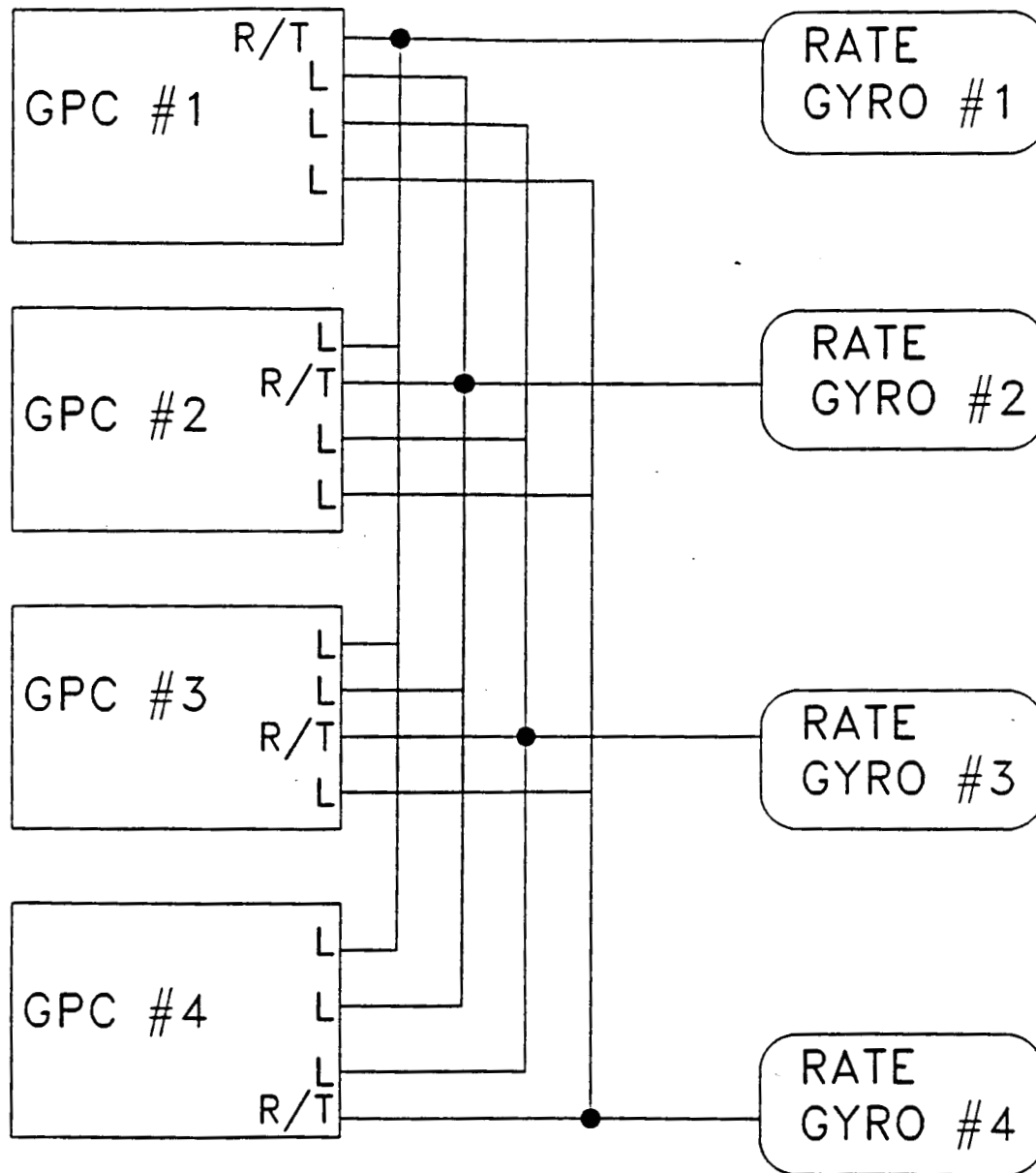

LISTEN MODE

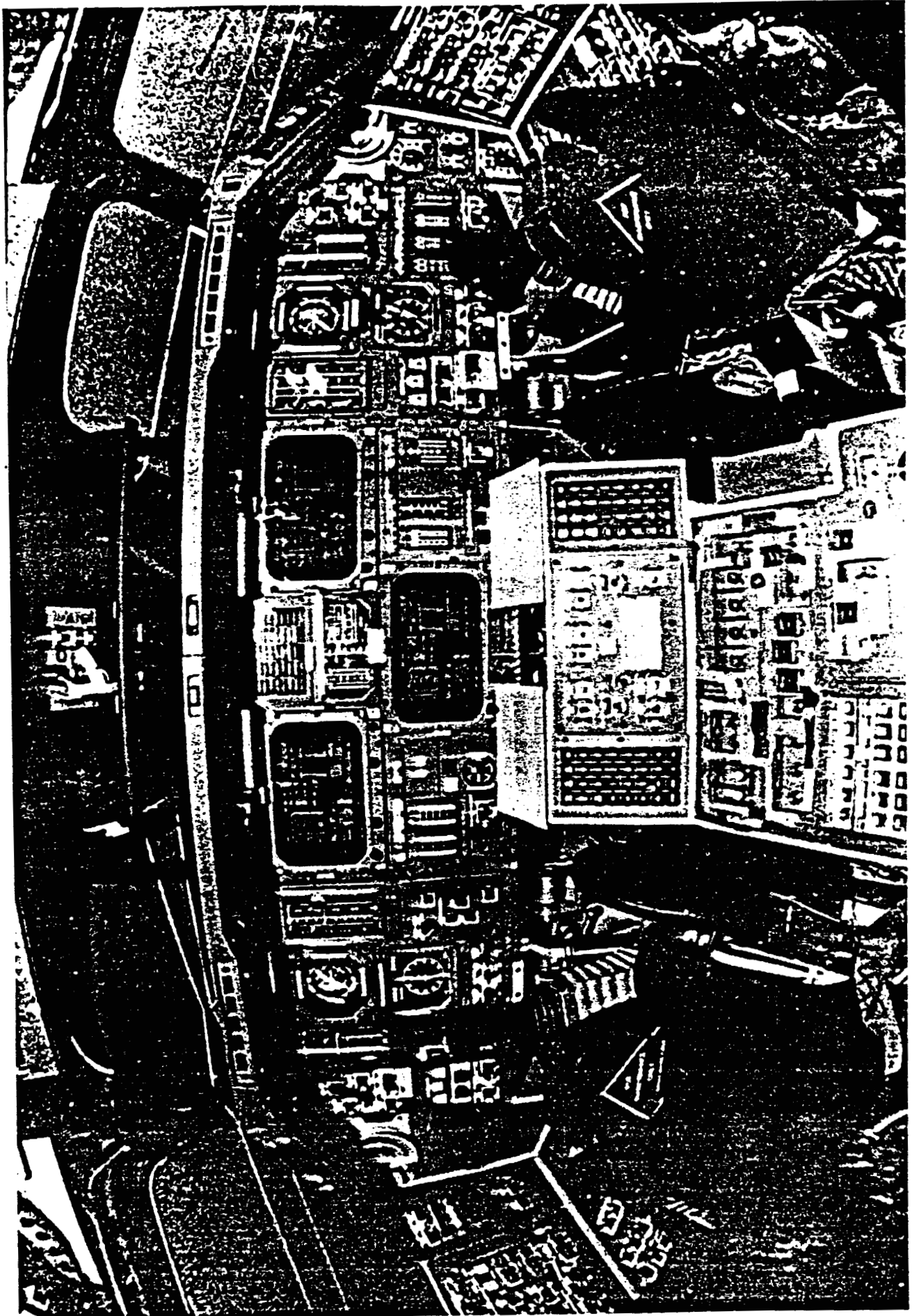

ORIGINAL PAGE IS  
OF POOR QUALITY

# PRIMARY AVIONICS SOFTWARE SYSTEM FUNCTIONS

- **MISSION CRITICAL SOFTWARE SYSTEM**
- **SUPPORTS ALL FLIGHT PHASES FROM PRE-LAUNCH CHECKOUT THROUGH ROLLOUT**
  - COMMANDS OR COMMUNICATES WITH HUNDREDS OF ONBOARD SYSTEMS
- **PREFLIGHT**
  - VEHICLE SUBSYSTEMS CHECKOUT
  - PAYLOAD CHECKOUT
  - PROPELLANT LOADING
  - TERMINAL COUNTDOWN SEQUENCING (E.G., ENGINE START)
- **ASCENT**
  - AUTOMATIC AND MANUAL GUIDANCE, NAVIGATION AND FLIGHT CONTROL
  - NOMINAL LAUNCH SEQUENCE (E.G., BOOSTER STAGING)
  - ABORT SEQUENCING (E.G., RTLS, TAL, AOA, ATO)



# PRIMARY AVIONICS SOFTWARE SYSTEM FUNCTIONS

(continued)

- ORBIT
  - AUTOMATIC AND MANUAL GUIDANCE, NAVIGATION AND FLIGHT CONTROL
  - VEHICLE SUBSYSTEM MONITORING/FAULT DETECTION/ANNUNCIATION
  - PAYLOAD MONITORING, CONTROL, DEPLOYMENT
  - REMOTE MANIPULATOR ARM CONTROL
  - PAYLOAD BAY DOOR OPERATION
  - COMMUNICATIONS ANTENNA MANAGEMENT
  - ENTRY SYSTEMS CHECKOUT
  
- ENTRY
  - COMPUTATIONS FOR DEORBIT ENGINE FIRING (TARGETING)
  - AUTOMATIC AND MANUAL GUIDANCE, NAVIGATION AND FLIGHT CONTROL (THROUGH ROLLOUT AND BRAKING)

# SOFTWARE CRITICAL TO NASA SHUTTLE

## SOFTWARE CONFIGURATION FOR A TYPICAL SHUTTLE FLIGHT

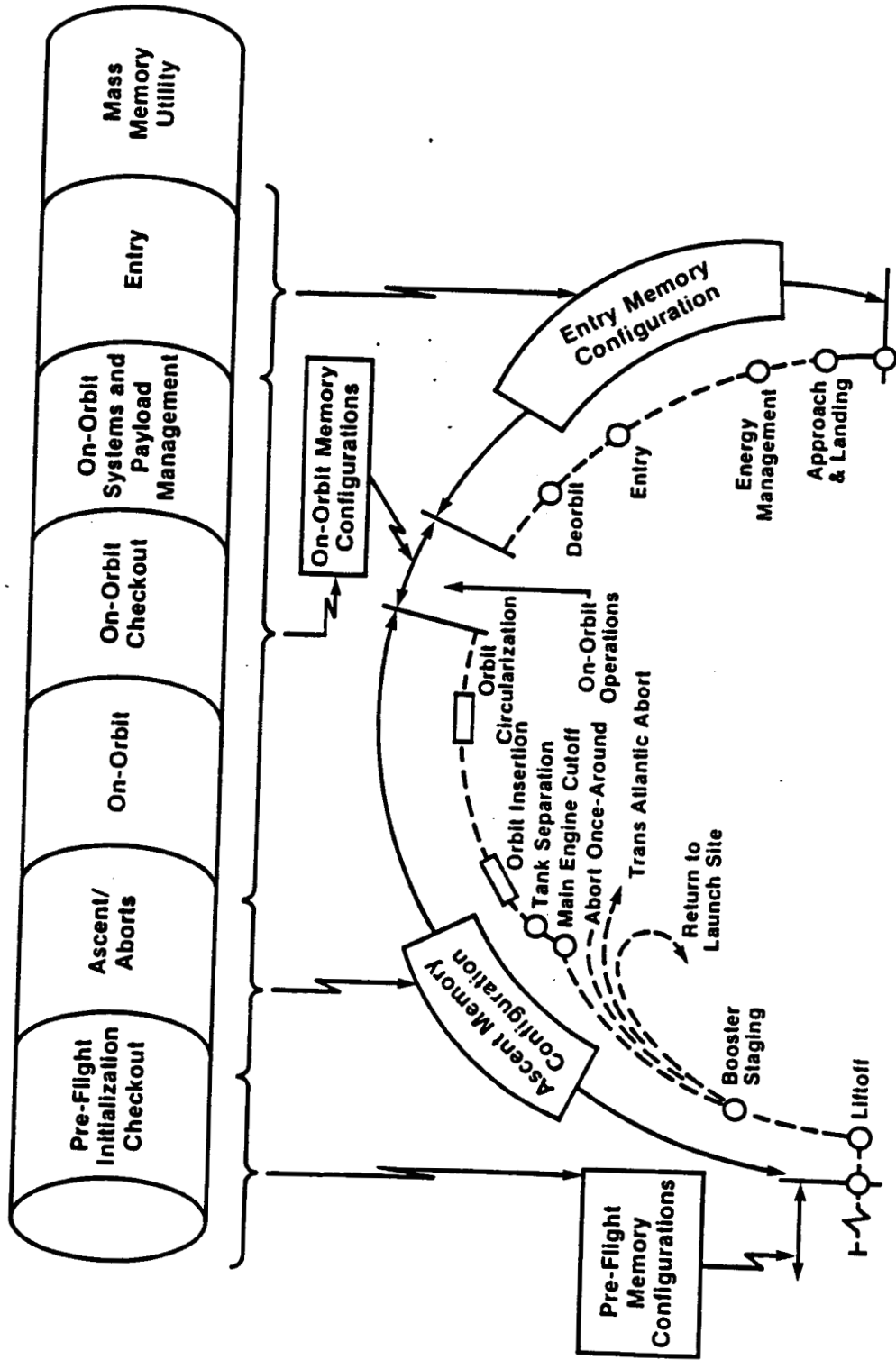



## Users Of On-board Shuttle Flight Software

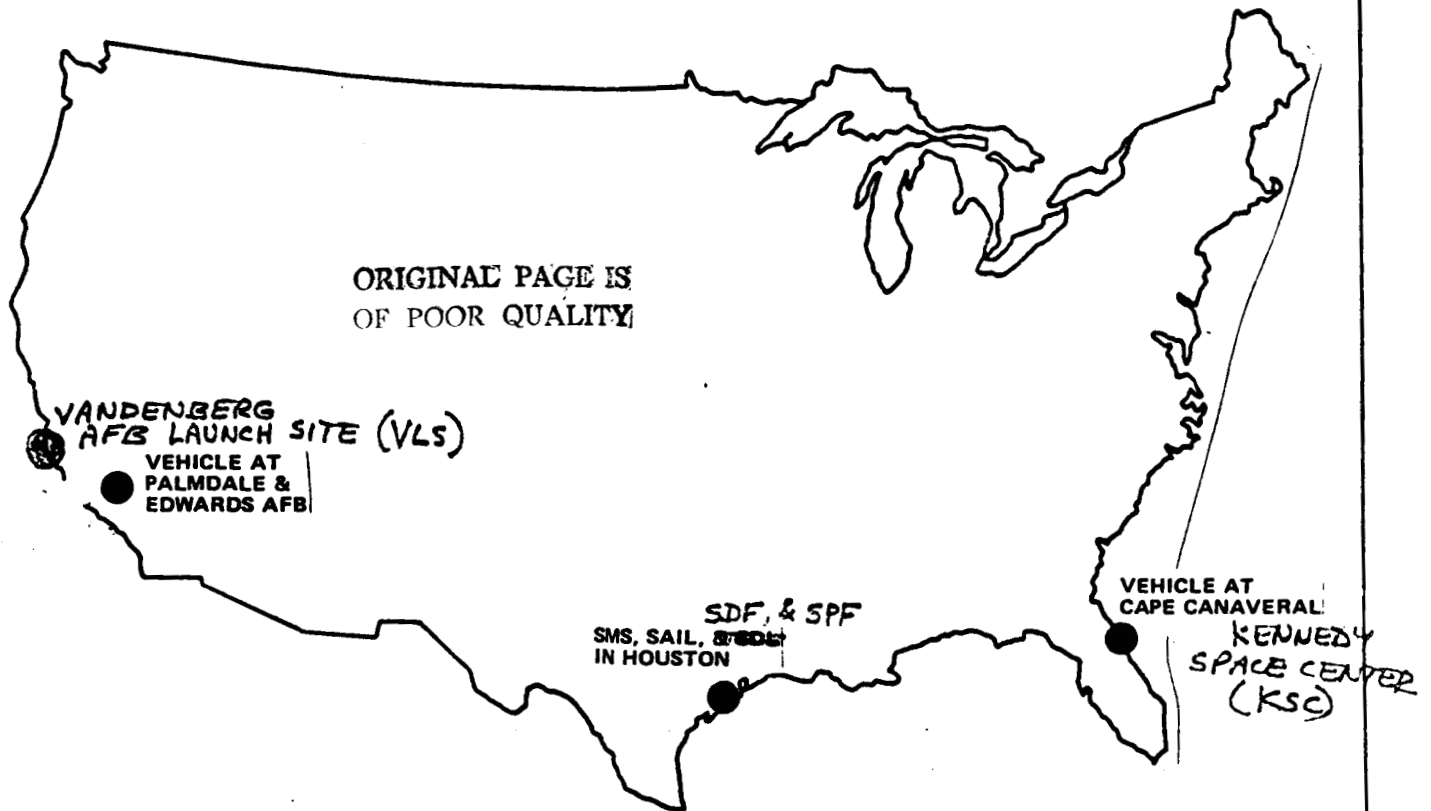

THERE ARE NINE PLACES WHERE ON-BOARD PRIMARY SOFTWARE DEVELOPED FOR THE SPACE SHUTTLE MAY BE IN USE:

- o VEHICLE IN ORBIT
- o VEHICLE AT CAPE CANAVERAL PREFLIGHT (KSC)
- o VEHICLE AT EDWARDS AFB POSTFLIGHT
- o SHUTTLE MISSION SIMULATOR (SMS)
- o SHUTTLE AVIONICS INTEGRATION LABORATORY (SAIL)
- o SOFTWARE DEVELOPMENT FACILITY (SDF)
- o SOFTWARE PRODUCTION FACILITY (SPF)
- o NEW ORBITER UNDER CONSTRUCTION AT PALMDALE
- o VEHICLE AT VANDENBERG AFB PREFLIGHT (VLS)

**SOFTWARE DEVELOPMENT APPROACH**



# OPERATIONAL INCREMENT DEVELOPMENT MILESTONES

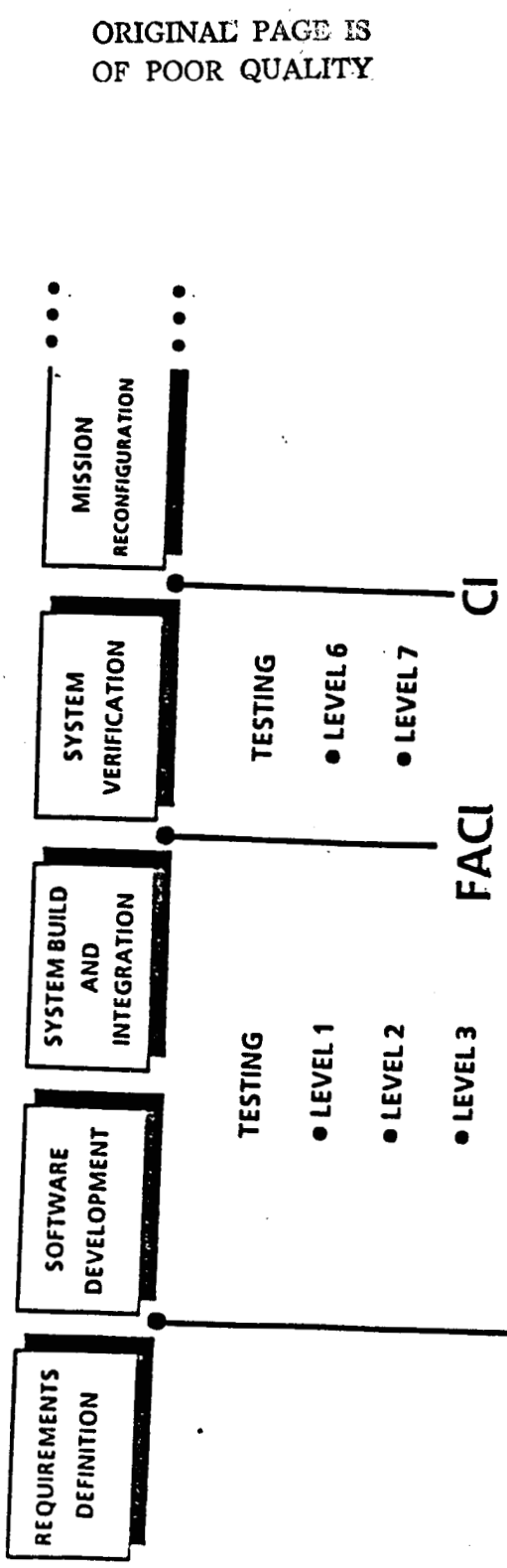

ORIGINAL PAGE IS OF POOR QUALITY

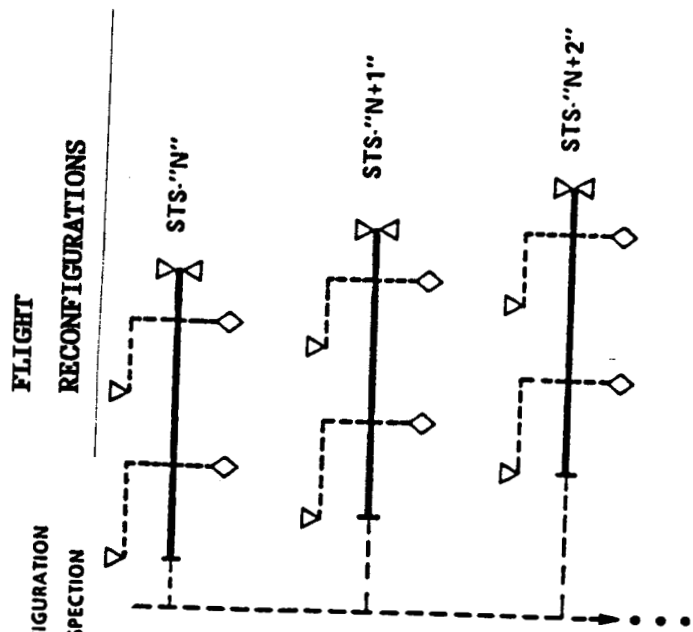

- ⊗ - LAUNCH DATE
- ◇ - SOFTWARE RELEASE TO CUSTOMER
- ▽ - FLIGHT SPECIFIC REQUIREMENTS

# SOFTWARE CRITICAL TO NASA SHUTTLE

## SOFTWARE DEVELOPMENT PROCESS

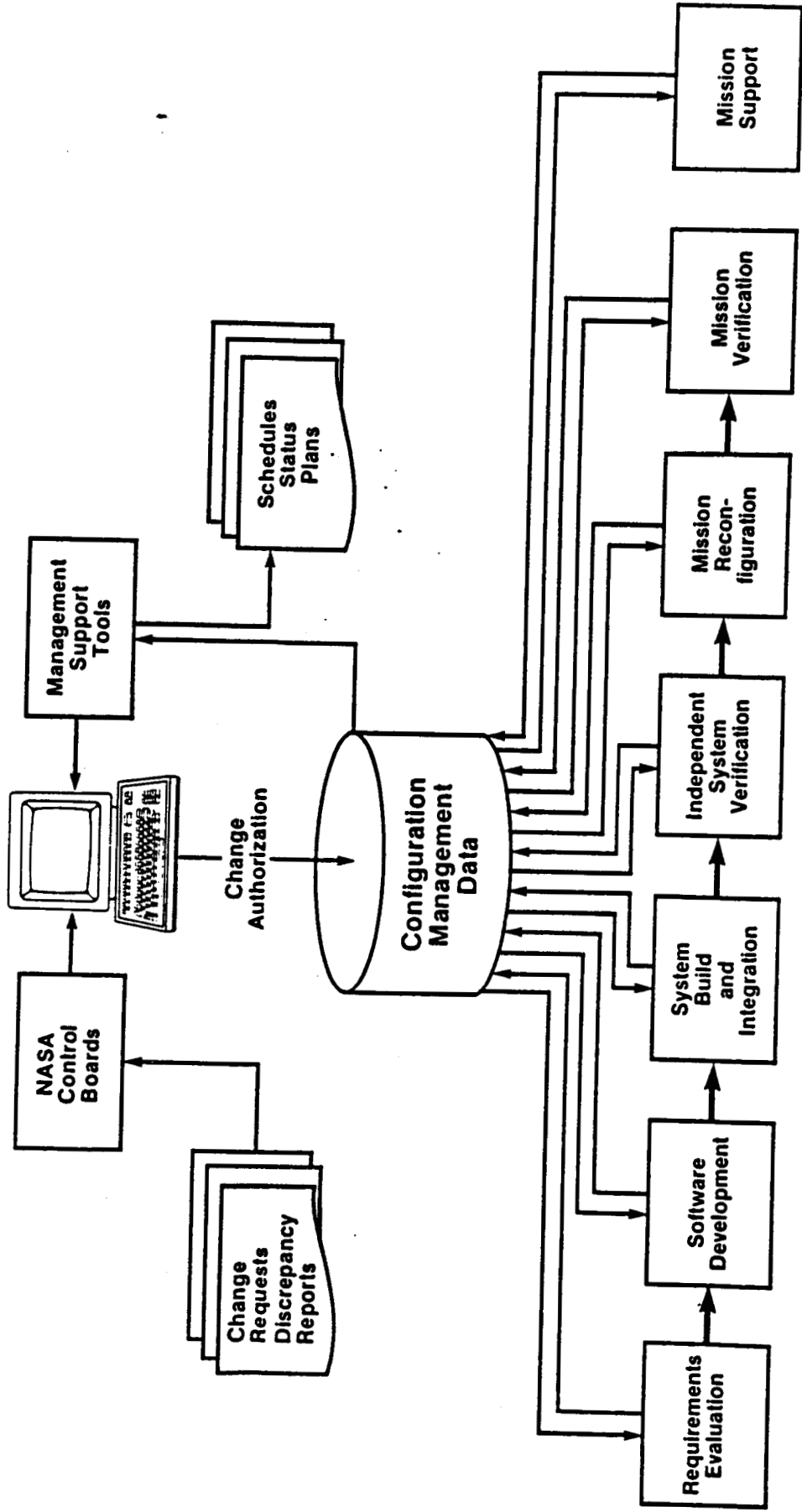

## **SOFTWARE DEVELOPMENT APPROACH**

- **MAJOR DEPARTMENT AREAS**
  - REQUIREMENTS ANALYSIS & SYSTEM ARCHITECTURE
  - SOFTWARE DEVELOPMENT
  - SYSTEM BUILD AND INTEGRATION
  - INDEPENDENT VERIFICATION
  - CUSTOMER AND FIELD SUPPORT
  - RECONFIGURATION/CERTIFICATION
  
- **CONFIGURATION CONTROL (CONTROL BOARD STRUCTURE)**

# SHUTTLE ONBOARD SOFTWARE ORGANIZATION

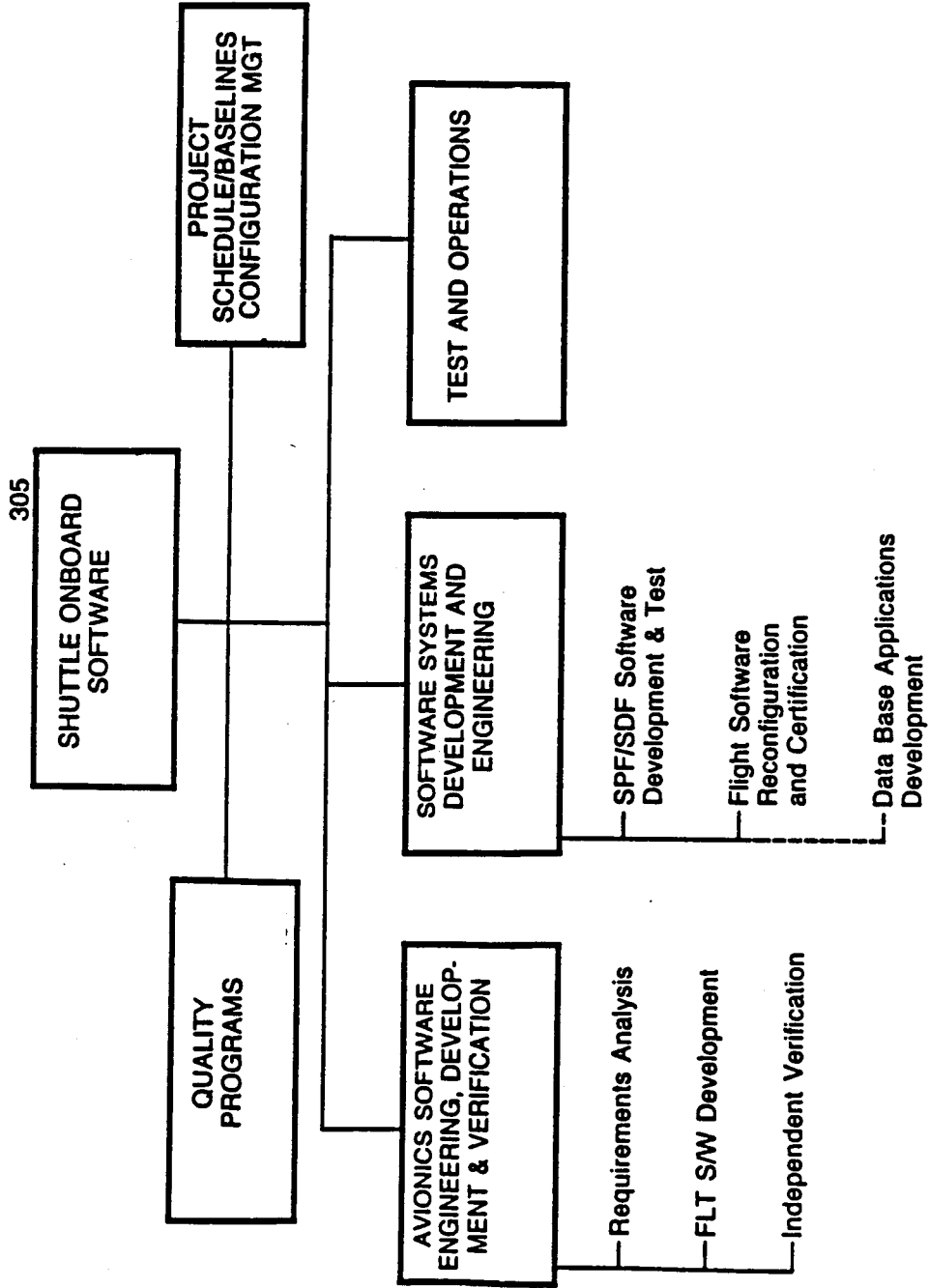





# PROJECT CONTROL BOARD STRUCTURE

- PROJECT WIDE CONFIGURATION CONTROL MAINTAINED BY 5 CONTROL BOARDS
  - PROJECT SCHEDULING AND OVERALL COORDINATION (BCB)
  - SOFTWARE REQUIREMENTS (RRB)
  - SOFTWARE DISCREPANCIES (DRB)
  - PROGRAMMING STANDARDS AND SYSTEM ARCHITECTURE (SARB)
  - SUPPORT SOFTWARE AND TEST BED (SSRB)
- CHAIRED BY KEY STAFF PERSONNEL
- REPRESENTATION BY ALL PROJECT AREAS (DEVELOPMENT, VERIFICATION, ETC.)

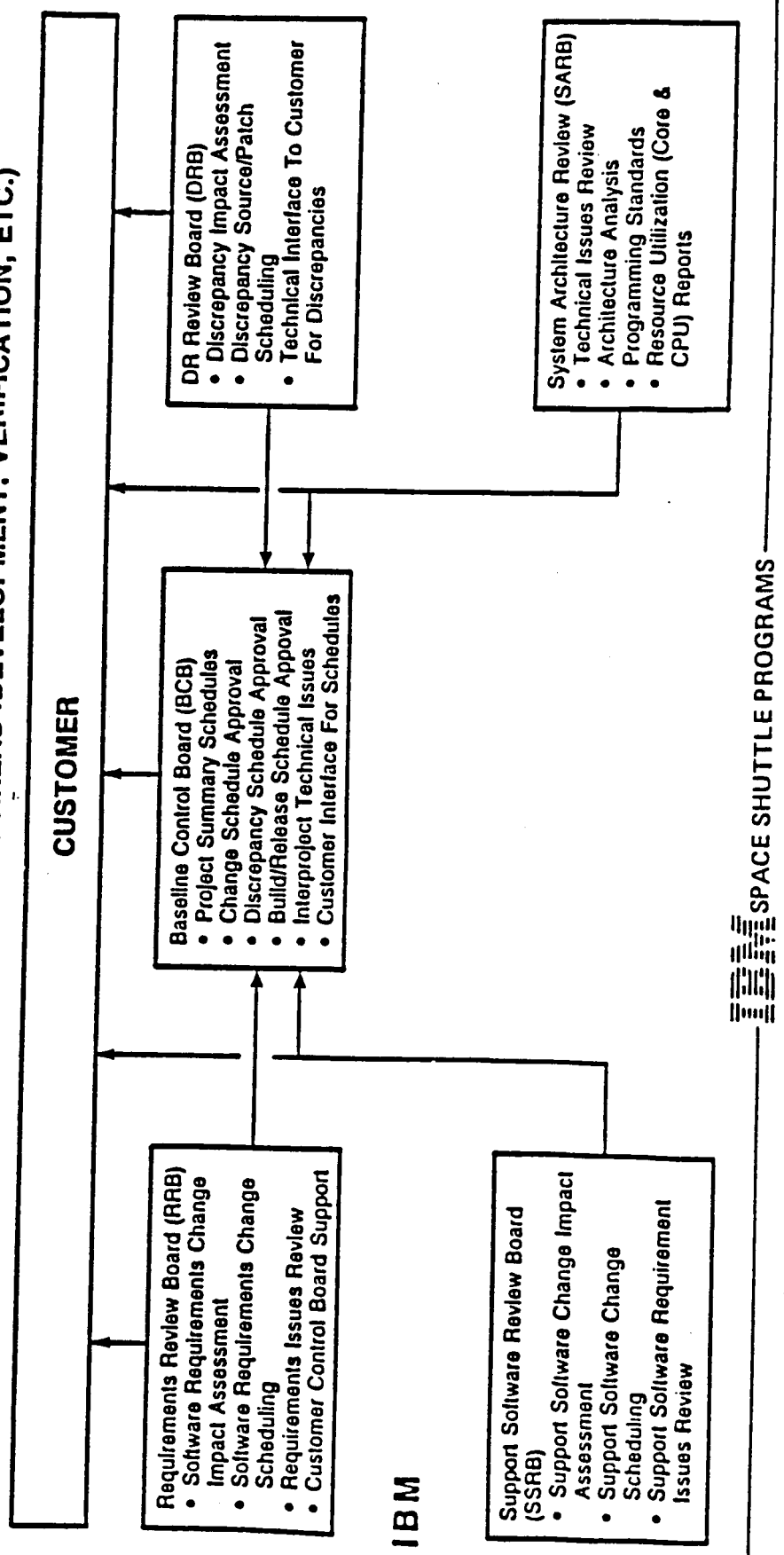

# SOFTWARE CRITICAL TO NASA SHUTTLE

## ONBOARD SHUTTLE SOFTWARE DEVELOPMENT

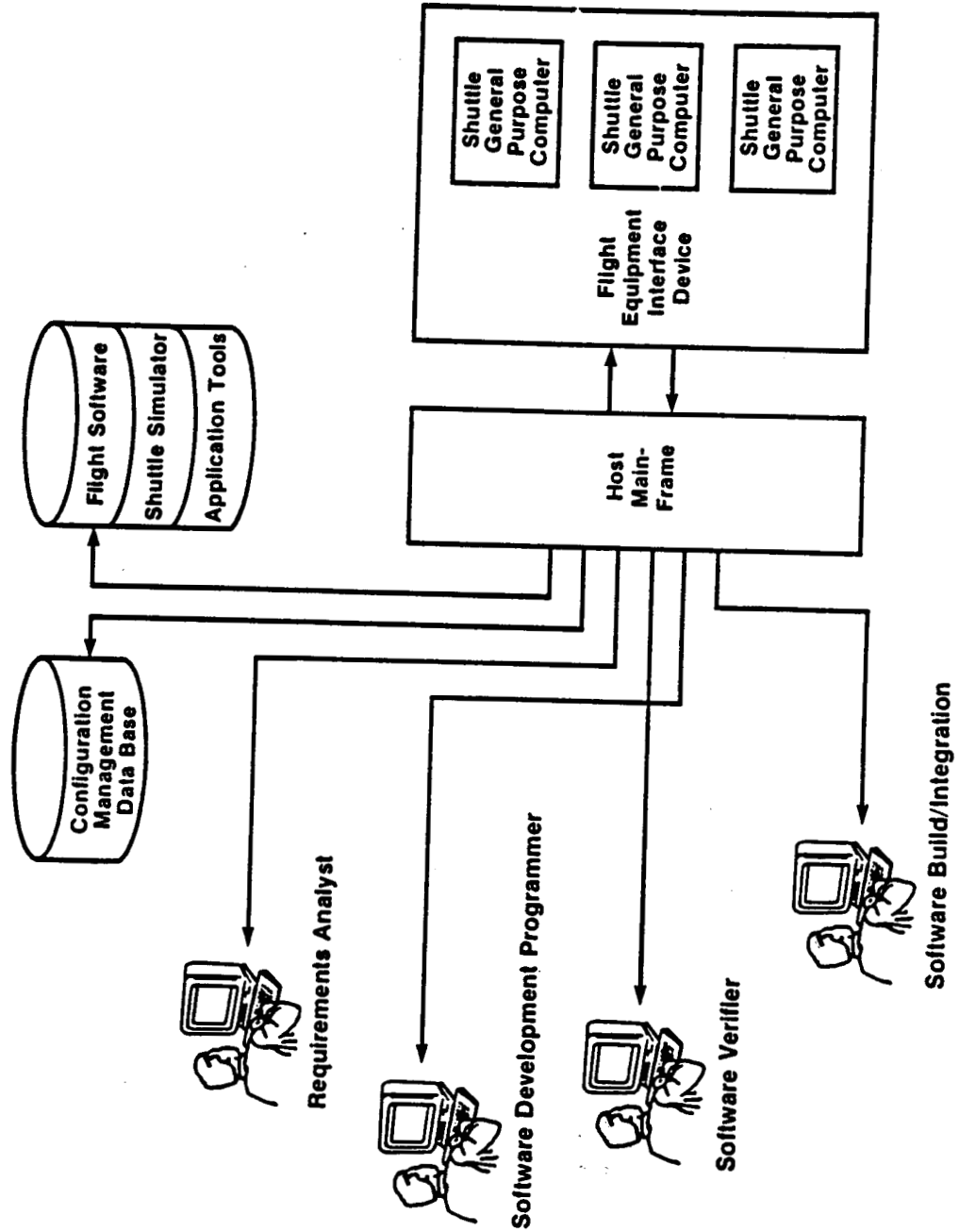

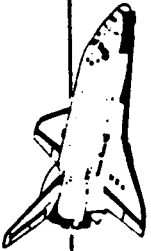

## REQUIREMENTS ANALYSIS

- **DEDICATED REQUIREMENTS ANALYSIS GROUP FORMED TO INTERFACE WITH CUSTOMER AND DEVELOPMENT ORGANIZATION RESPONSIBILITIES INCLUDE:**
  - ASSESSMENT OF CUSTOMER SUPPLIED REQUIREMENTS
  - GENERATION OF SOFTWARE REQUIREMENTS
- **FUNCTIONS**
  - REQUIREMENTS AND DESIGN TRADEOFFS
  - ENSURE REQUIREMENTS MATURITY, COMPLETENESS, CLARITY
  - HARDWARE/FIRMWARE/SOFTWARE COMPATIBILITY
  - CPU AND MEMORY CONSTRAINT CONSIDERATIONS
  - TESTABILITY OF REQUIREMENTS
- **TECHNIQUES AND TOOLS**
  - CONCEPTUAL DESIGN TEAM CONCEPT TO ADDRESS EACH FUNCTIONAL AREA (CUSTOMER INVOLVEMENT)
  - FORMAL REQUIREMENTS REVIEWS WITH SOFTWARE DEVELOPMENT, VERIFICATION AND FIELD SUPPORT PERSONNEL REPRESENTATION
    - MECHANISM FOR COMMUNICATION OF REQUIREMENT "LETTER" AND "INTENT"
  - ANALYTICAL MODELING OF SOFTWARE SYSTEM
- **OTHER RESPONSIBILITIES**
  - SYSTEM LEVEL (OPERATIONAL) TEST RESPONSIBILITY
  - CONSULTATION TO ALL PROJECT AREAS (DEVELOPMENT, TEST, CUSTOMER, FIELD SUPPORT)
  - CHANGE CONTROL BOARD MEMBERSHIP



## SOFTWARE DEVELOPMENT

- INDEPENDENT ORGANIZATION SEPARATE FROM REQUIREMENTS ANALYSIS, VERIFICATION, AND CUSTOMER SUPPORT GROUPS
- FUNCTIONS
  - PARTICIPATION IN INITIAL REQUIREMENTS BASELINE OR CHANGE ASSESSMENT AND SCHEDULING
  - FUNCTIONAL AND DETAILED DESIGN
  - CODE IMPLEMENTATION
  - MODULE LEVEL UNIT TESTING (LEVEL 1)
  - FUNCTIONAL LEVEL TESTING (MODULE TO MODULE INTERFACES, LEVEL 2)
  - SUBMITTAL TO SYSTEM BUILD
  - DESIGN DOCUMENTATION
- TECHNIQUES AND TOOLS
  - FORMAL, HIGHLY STRUCTURED DESIGN AND CODE INSPECTIONS
    - TRAINED MODERATORS AND PEER PARTICIPATION
    - REPRESENTATIVES FROM REQ'TS ANALYSIS AND VERIFICATION
    - CHECKLISTS WITH FORMAL SIGNOFF
    - CODE AUDITING TOOLS
    - ISSUES FORMALLY TRACKED AND DISPOSITIONED
  - TESTING PERFORMED ON OPERATIONAL HARDWARE
  - INTERIM MILESTONES TRACKED AT PROGRAMMER AND MODULE LEVEL AGAINST AUTOMATED DEVELOPMENT PLAN
    - DESIGN START AND COMPLETE, CODE START AND COMPLETE, ETC.
    - RESPONSIBLE FOR IMPLEMENTATION OF ALL DISCREPANCY CORRECTIONS
  - FORMALIZED FEEDBACK AND ANALYSIS OF SOFTWARE DISCREPANCIES
    - ANALYSIS OF INDIVIDUAL DISCREPANCIES TO IDENTIFY WEAKNESSES IN THE PROCESS
    - TREND ANALYSIS

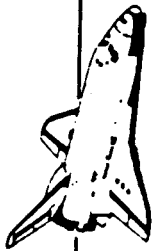

# SHUTTLE AVIONICS SOFTWARE LEVELS OF TESTING

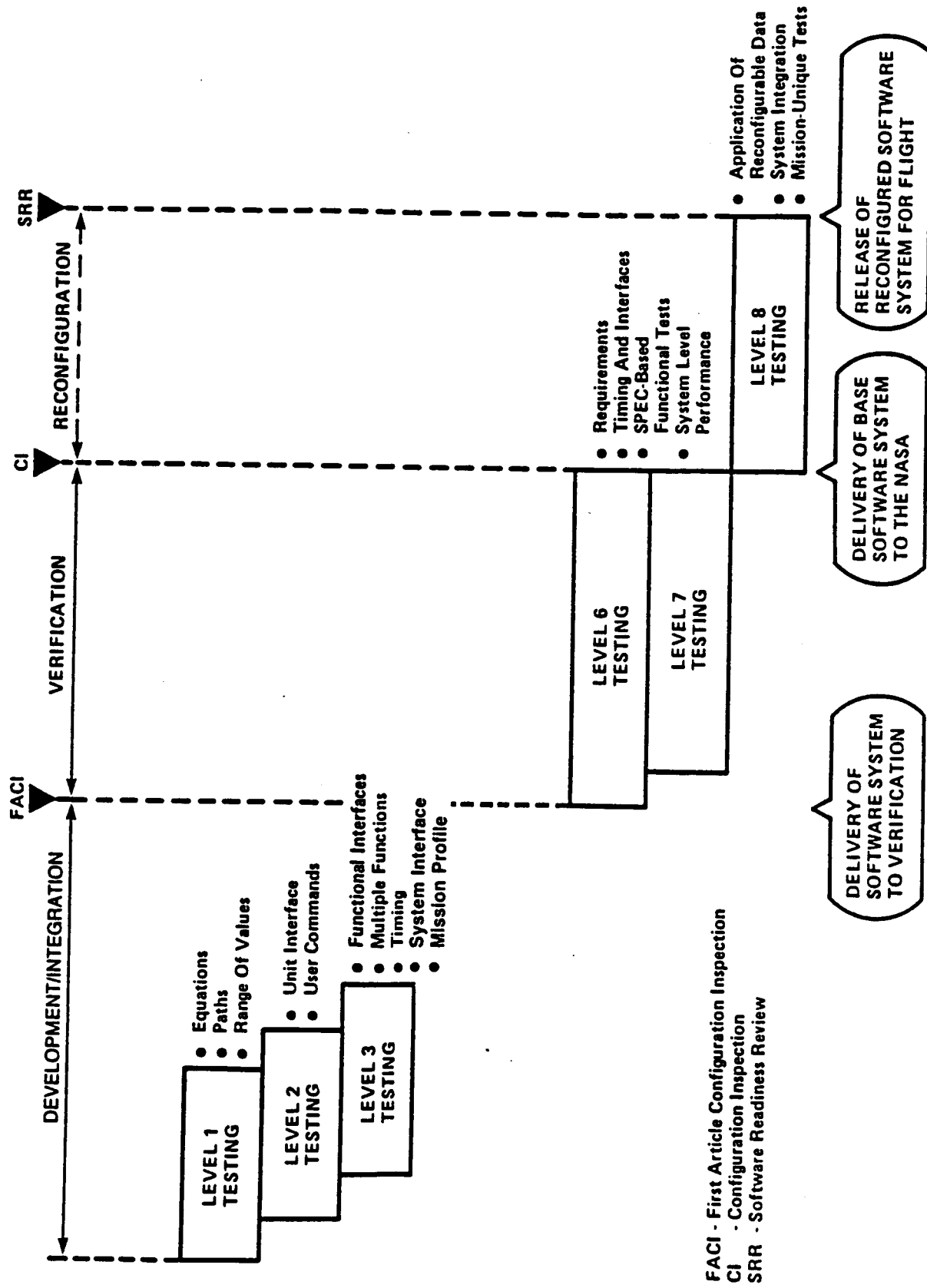

# **SYSTEM BUILD AND INTEGRATION**

- **PRIMARY ELEMENTS**
  - **AUTOMATED SYSTEM BUILD**
  - **MASS MEMORY INTEGRATION**

## **PASS SYSTEM BUILD**

- **ONLINE INTERACTIVE TRANSACTIONS (MENUS) PROVIDE AUTOMATED BUILD CONTROL**
- **UPDATED SOURCE MODULES AND NEW MODULES ARE PLACED INTO PERMANENT SYSTEM CONFIGURATION CONTROLLED DATA SETS**
- **A BUILD CONTROL LIST DRIVES THE SYSTEM BUILD PROCESS USING CONFIGURATION CONTROL INFORMATION FROM THE CONFIGURATION MANAGEMENT DATA BASE**
- **CONSISTENCY BETWEEN UPDATED SOURCE AND EXECUTABLE LOAD MODULES IS INSURED DURING COMPILATION AND LINK EDIT STEPS**
- **A SOURCE DEPENDENCY SCANNER AUTOMATICALLY IDENTIFIES OTHER SOURCE MODULES WHICH MUST BE RECOMPILED DUE TO DEPENDENCIES ON SOURCE BEING UPDATED**
- **A RECOMPILE DIRECTOR DETERMINES THE ORDER IN WHICH ALL SOURCE UPDATES MUST BE PERFORMED**
- **CHANGE ACCOUNTING INFORMATION (REVISION LEVEL) IS ADDED TO SOURCE LANGUAGE RECORDS AND IDENTIFICATION INFORMATION IS ADDED TO LOAD MODULES**
- **BUILD TERMINATION PROCESSING INDICATES STATUS OF ALL BUILT ITEMS IN THE CONFIGURATION MANAGEMENT DATA BASE**
- **NUMEROUS ANALYSIS REPORTS ARE OUTPUT FROM THE SYSTEM BUILD TOOLS, INCLUDING A LISTING TAPE OF ALL BUILT CHANGES**

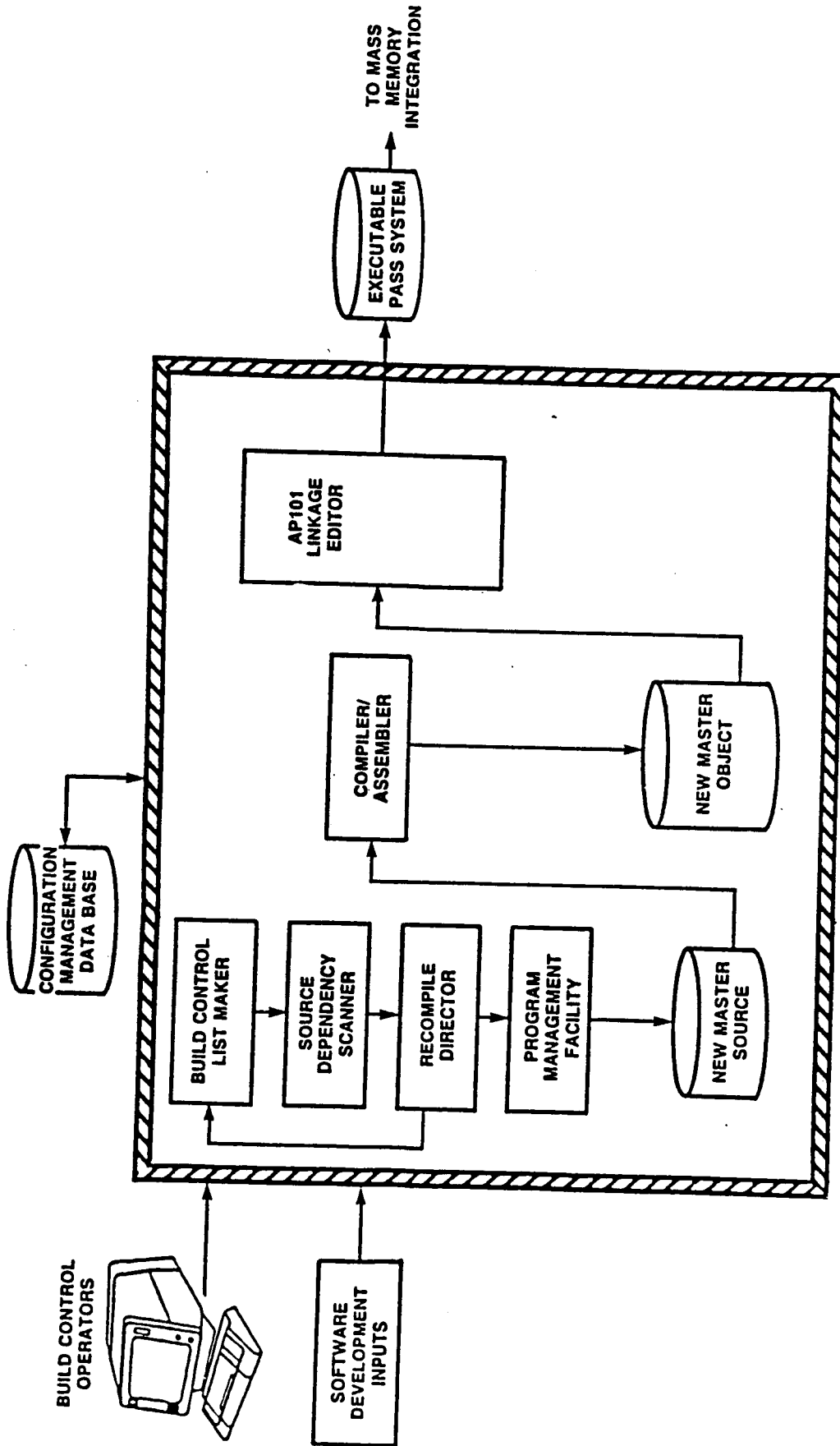

# PASS SYSTEM BUILD



## **MASS MEMORY INTEGRATION**

- **AN AUTOMATED PANEL DRIVEN SYSTEM BY WHICH SOFTWARE ELEMENTS IN ADDITION TO PASS ARE INTEGRATED AND MAPPED INTO THE FORMAT REQUIRED BY THE MASS MEMORY UNITS**
- **I-LOAD DATA NEEDED TO ALLOW SUCCESSFUL SYSTEM EXECUTION IS APPLIED TO THE MASS MEMORY VIA THE AUTO-I-LOAD PROCESSOR AND THE MASS MEMORY PATCH UTILITY**
- **SOFTWARE ELEMENTS ARE INTEGRATED ON THE MASS MEMORY UNIT**
  - **PRIMARY AVIONICS SOFTWARE SUBSYSTEM (PASS)**
  - **INITIAL PROGRAM LOAD**
  - **BACKUP FLIGHT SOFTWARE (BFS)**
  - **SPACE SHUTTLE MAIN ENGINE**
  - **TFL/DFL**
  - **TEST CONTROL SEQUENCES**
  - **TEXT AND GRAPHICS**
  - **DEU**
- **PRINTED MASS MEMORY MAPS, PHASE TABLES AND OTHER REPORTS ARE GENERATED**
- **DELIVERY LOAD TAPES OR DATA SETS ARE CREATED FOR USE BY FACILITIES/VEHICLE**

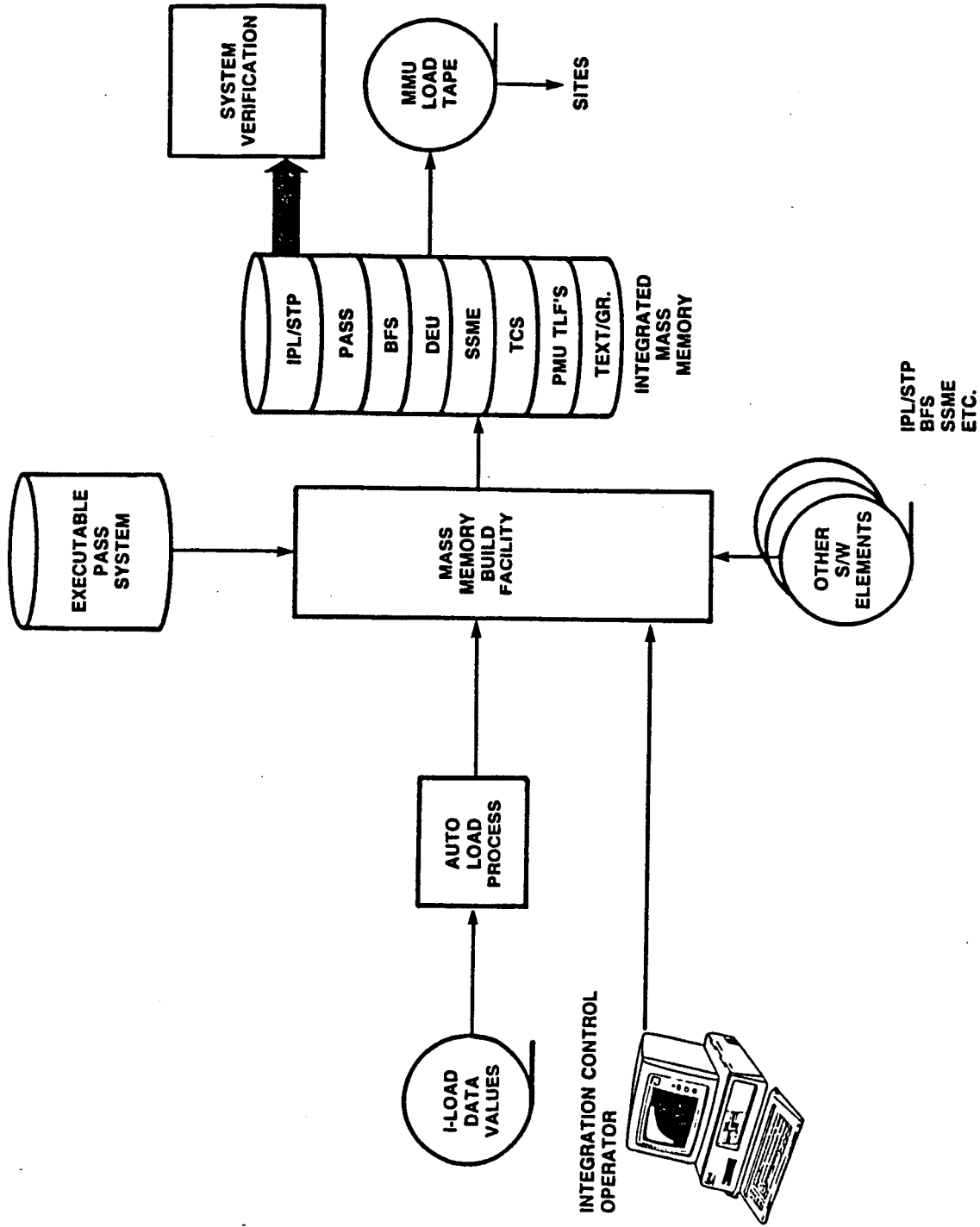

# MASS MEMORY INTEGRATION



# INDEPENDENT VERIFICATION

## INDEPENDENT MULTI-LEVEL TEST PROGRAM

- USED ON SHUTTLE ONBOARD SOFTWARE PROJECT
- ASSUMES SOFTWARE IS "UNTESTED"
- ALL TESTING PERFORMED ON OPERATIONAL DPS FLIGHT HARDWARE IN SOFTWARE DEVELOPMENT FACILITY
- TWO LEVELS OF TESTING PERFORMED ON OPERATIONAL HARDWARE BY SEPARATE ORGANIZATIONS
  - DETAILED/FUNCTIONAL TESTING (MODULE/FUNCTIONAL TESTS AGAINST REQ'TS AND DESIGN), ALSO CALLED "SPECIFICATION BASED FUNCTIONAL TESTING"
  - SYSTEM LEVEL PERFORMANCE TESTING UNDER OPERATIONAL CONDITIONS
- TEST STANDARDS AND FORMAL TEST CASE REVIEWS TO ASSURE QUALITY
- STATIC CODE ANALYSIS TO AUGMENT TESTING
- RESPONSIBLE FOR REGRESSION TESTING OF ALL CHANGES
- FORMALIZED FEEDBACK AND ANALYSIS OF SOFTWARE DISCREPANCIES
  - ANALYSIS OF INDIVIDUAL DISCREPANCIES TO IDENTIFY WEAKNESSES IN THE PROCESS
  - TREND ANALYSIS
- INTERIM MILESTONES TRACKED AT THE TEST ANALYST, MODULE OR CHANGE LEVEL
- COMPARISON TO AUTOMATED DEVELOPMENT PLAN
- DOCUMENTATION (TEST SPECIFICATIONS, PROCEDURES, SIMULATION CASES AND REPORTS)

ORIGINAL PAGE IS OF POOR QUALITY

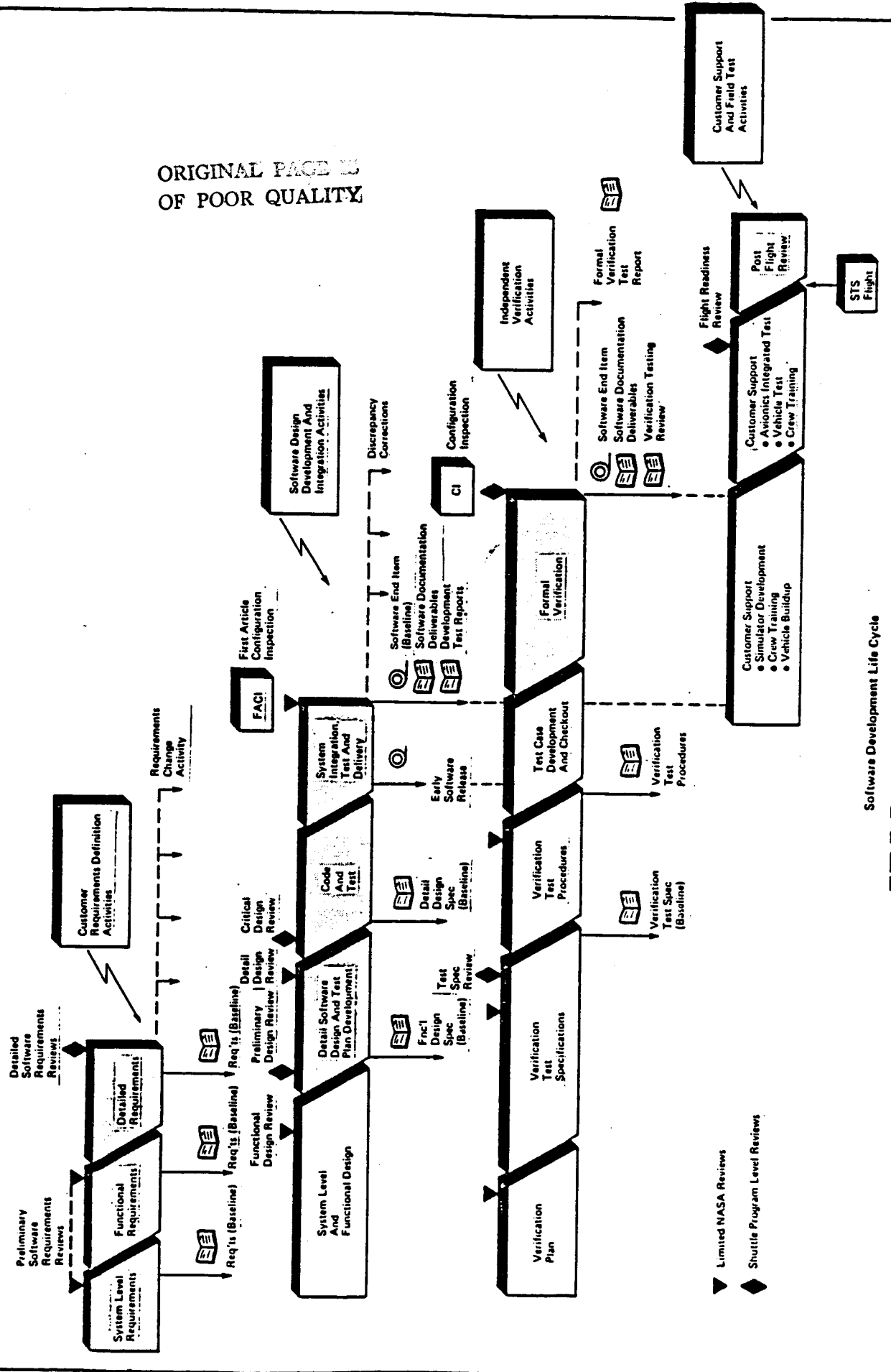

Software Development Life Cycle



SPACE SHUTTLE PROGRAMS

ORIGINAL PAGE IS  
OF POOR QUALITY

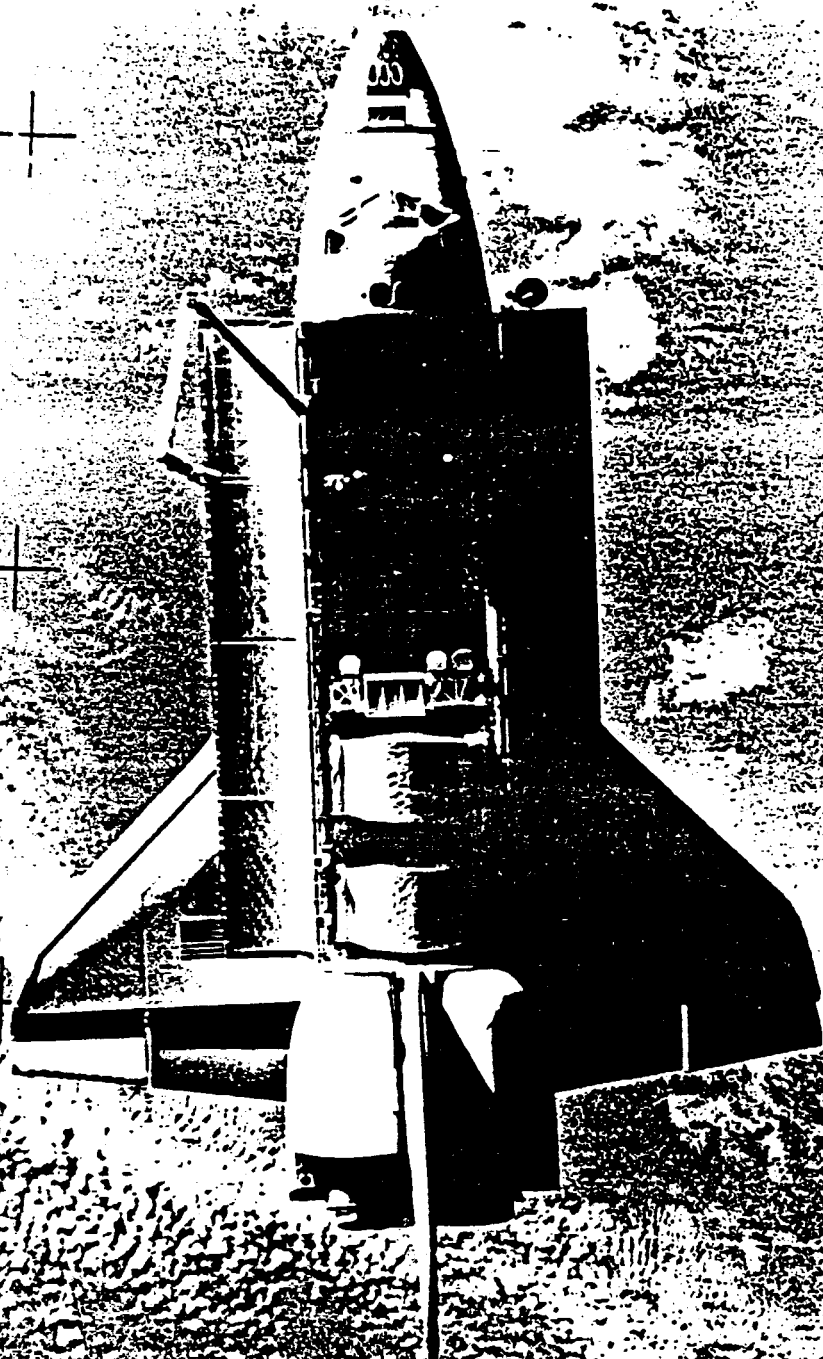

**USER SUPPORT  
AND  
PROBLEM DIAGNOSIS**

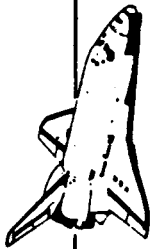

# **CUSTOMER SUPPORT AND FIELD OPERATIONS**

**FIELD SITE RESIDENT PERSONNEL WITH RESPONSIBILITIES AS FOLLOWS:**

- **SOFTWARE INSTALLATION AND MAINTENANCE**
- **USER TRAINING**
- **USER LIAISON**
- **CUSTOMER TEST SUPPORT**
- **OPERATIONS SUPPORT**



# TEST AND OPERATIONS ORGANIZATION INTERFACES

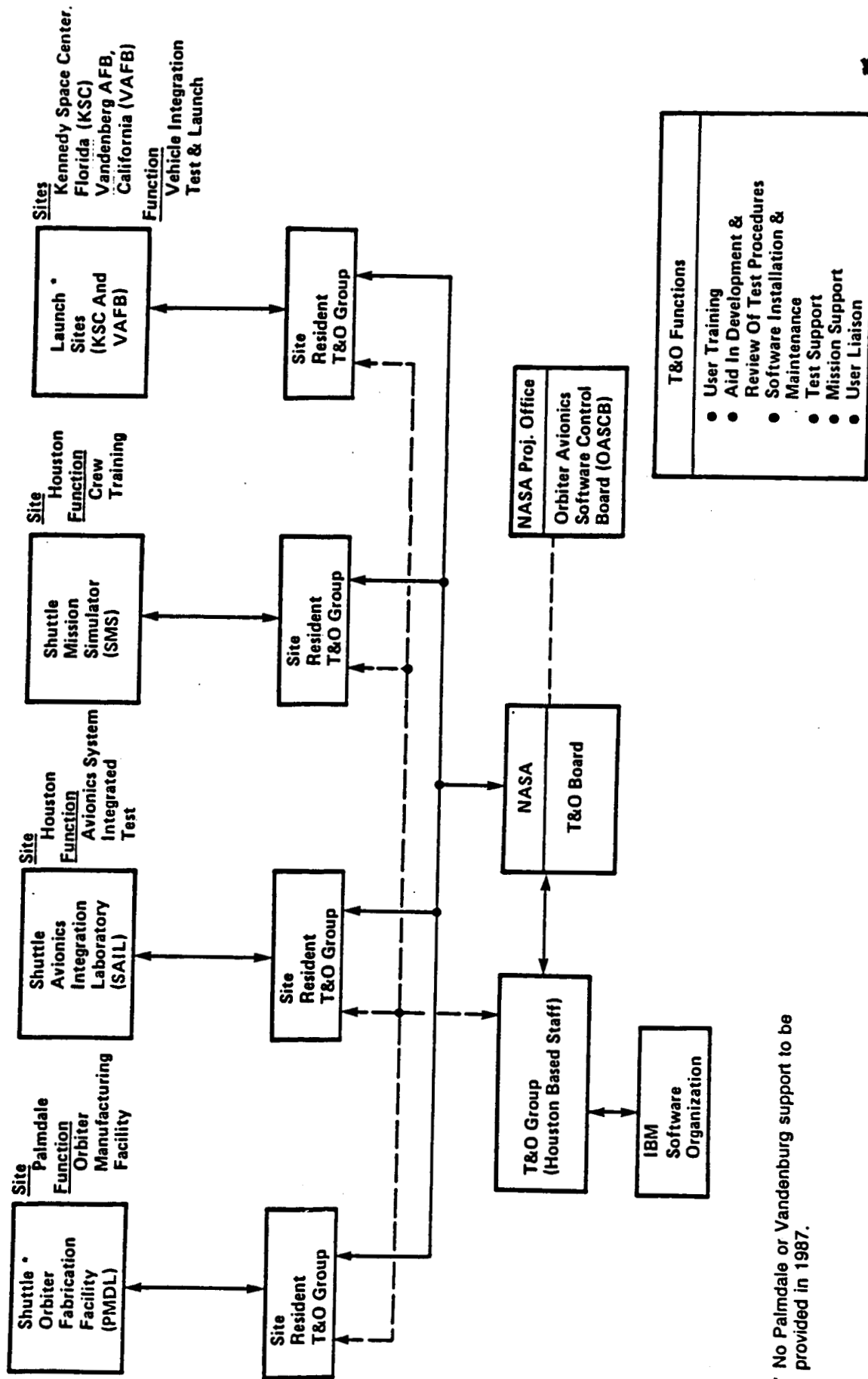

\* No Palmdale or Vandenberg support to be provided in 1987.



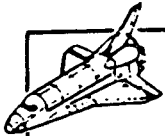

# IBM PROBLEM DIAGNOSIS

SIMULATIONS  
AND TRAINING

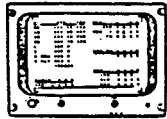

IN FLIGHT

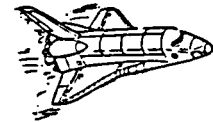

## INITIAL CLUES

- DISPLAYS (PHOTOS)
- VERBAL DESCRIPTIONS
- VEHICLE DYNAMICS
- LOG OF KEYBOARD INPUTS
- MEMORY DUMPS
- TELEMETRY DOWNLIST
- CONSOLE LOGS
- TABULAR PARAMETRIC DATA

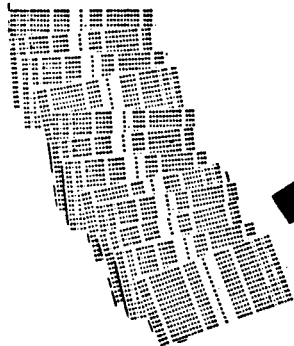

VERIFICATION  
AND TESTING



GROUND SUPPORT

PROBLEM



IBM  
FLIGHT  
SOFTWARE  
SUPPORT

DIAGNOSIS



MATRIX OF  
EXPERTISE

RESOLUTION



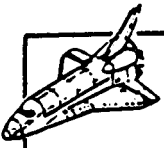

# FACT FINDING

- 1. QUESTION THE WITNESS  
- WHAT DID HE OBSERVE

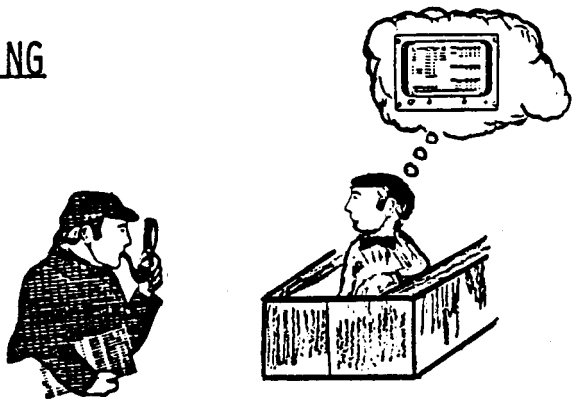

- 2. DETERMINE FLIGHT SCENARIO SURROUNDING PROBLEM

MEMORY CONFIGURATION  
MANEUVERS EXECUTED  
KEYSTROKES ENTERED  
FAILURES EXPERIENCED

⋮

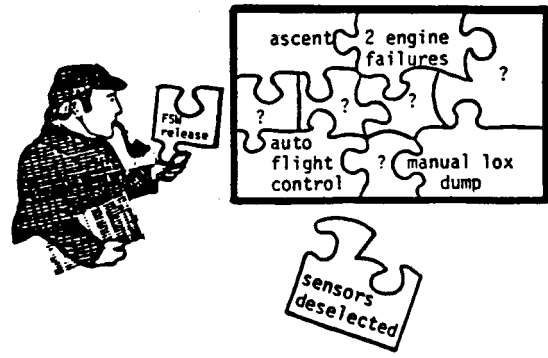

- 3. SEARCH FOR USERS WITH SIMILAR SYMPTOMS

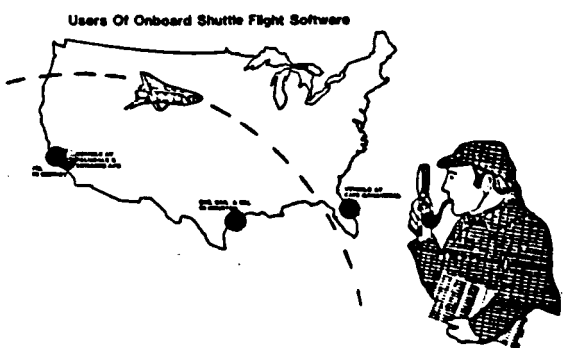

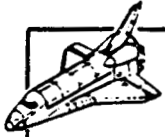

## INVESTIGATION TECHNIQUES

- USE APPROPRIATE DIAGNOSTIC TECHNIQUES
  - PROGRAM CROSS REFERENCE
  - MAGNIFIED TIMELINES
  - CAUSE AND EFFECT GRAPHS
  - CYCLIC/MULTIPASS EVALUATIONS
  - TRAP PATCHES/TRACES
  - PROCESS DESENSITIZATION
  - COMMON DENOMINATOR DETERMINATION
  
- EVALUATE FSW RESPONSE TO HYPOTHESIZED INPUTS
  - CODE WALK-THROUGH/MENTAL INSPECTION
  - EXECUTION TEST
  - REVISE HYPOTHESIS
  - CHALLENGE ASSUMPTIONS



# PROBLEM ISOLATION

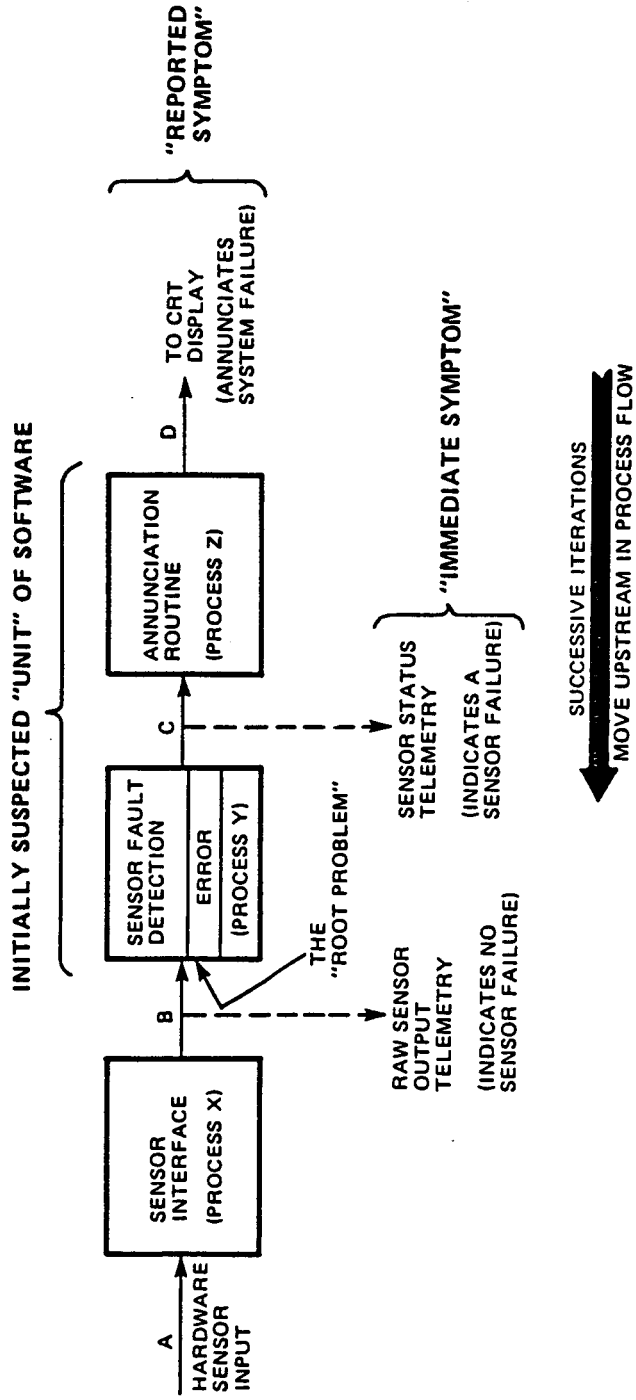

# THE GN&C FSU PROBLEM ANALYSIS PROCESS

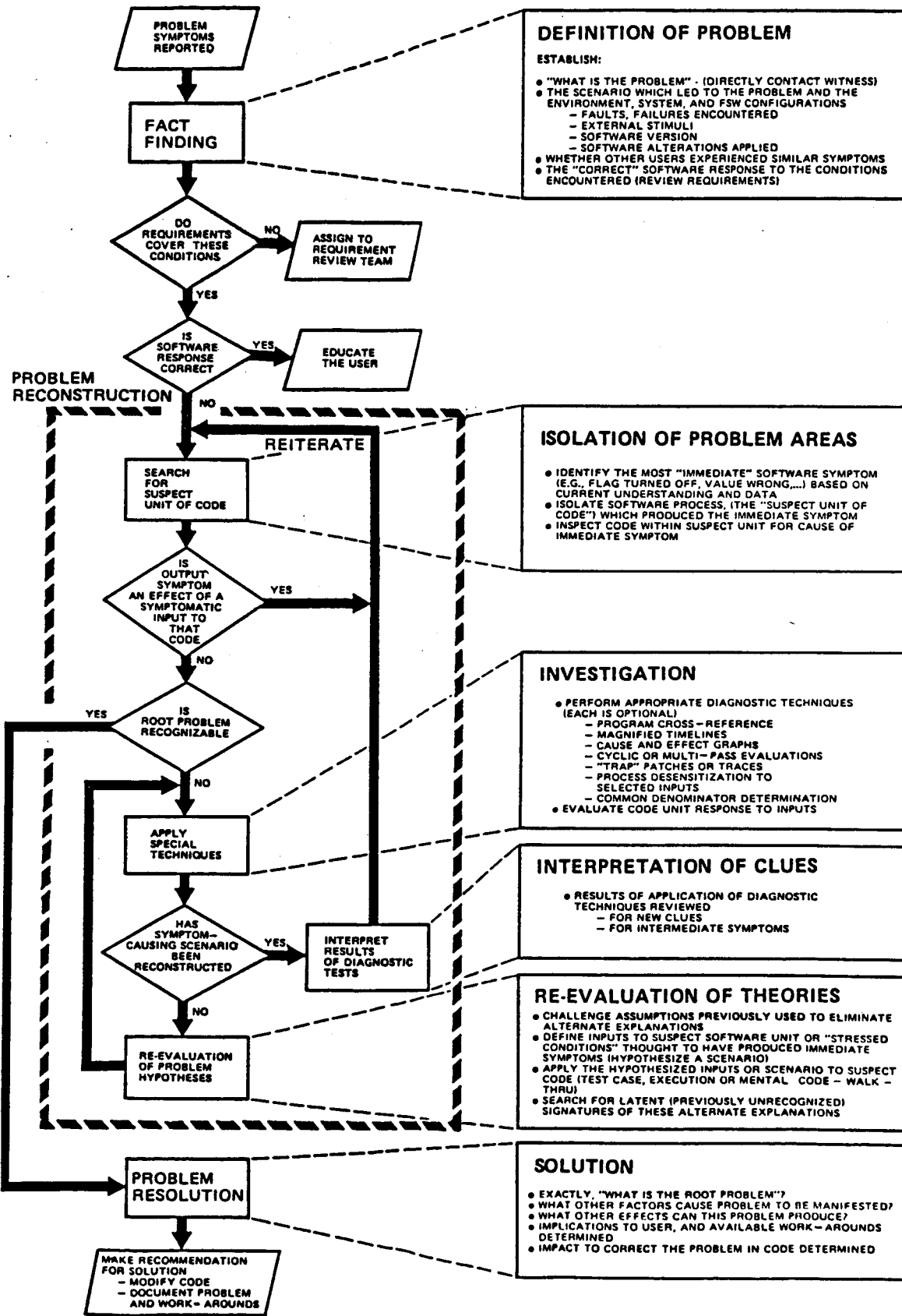
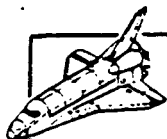

**DEFINITION OF PROBLEM**

ESTABLISH:

- "WHAT IS THE PROBLEM" - (DIRECTLY CONTACT WITNESS)
- THE SCENARIO WHICH LED TO THE PROBLEM AND THE ENVIRONMENT, SYSTEM, AND FSU CONFIGURATIONS
  - FAULTS, FAILURES ENCOUNTERED
  - EXTERNAL STIMULI
  - SOFTWARE VERSION
  - SOFTWARE ALTERATIONS APPLIED
- WHETHER OTHER USERS EXPERIENCED SIMILAR SYMPTOMS
- THE "CORRECT" SOFTWARE RESPONSE TO THE CONDITIONS ENCOUNTERED (REVIEW REQUIREMENTS)

**ISOLATION OF PROBLEM AREAS**

- IDENTIFY THE MOST "IMMEDIATE" SOFTWARE SYMPTOM (E.G., FLAG TURNED OFF, VALUE WRONG,...) BASED ON CURRENT UNDERSTANDING AND DATA
- ISOLATE SOFTWARE PROCESS, (THE "SUSPECT UNIT OF CODE") WHICH PRODUCED THE IMMEDIATE SYMPTOM
- INSPECT CODE WITHIN SUSPECT UNIT FOR CAUSE OF IMMEDIATE SYMPTOM

**INVESTIGATION**

- PERFORM APPROPRIATE DIAGNOSTIC TECHNIQUES (EACH IS OPTIONAL)
  - PROGRAM CROSS-REFERENCE
  - MAGNIFIED TIMELINES
  - CAUSE AND EFFECT GRAPHS
  - CYCLIC OR MULTI-PASS EVALUATIONS
  - "TRAP" PATCHES OR TRACES
  - PROCESS DESENSITIZATION TO SELECTED INPUTS
  - COMMON DENOMINATOR DETERMINATION
- EVALUATE CODE UNIT RESPONSE TO INPUTS

**INTERPRETATION OF CLUES**

- RESULTS OF APPLICATION OF DIAGNOSTIC TECHNIQUES REVIEWED
  - FOR NEW CLUES
  - FOR INTERMEDIATE SYMPTOMS

**RE-EVALUATION OF THEORIES**

- CHALLENGE ASSUMPTIONS PREVIOUSLY USED TO ELIMINATE ALTERNATE EXPLANATIONS
- DEFINE INPUTS TO SUSPECT SOFTWARE UNIT OR "STRESSED CONDITIONS" THOUGHT TO HAVE PRODUCED IMMEDIATE SYMPTOMS (HYPOTHEZIZE A SCENARIO)
- APPLY THE HYPOTHEZIZED INPUTS OR SCENARIO TO SUSPECT CODE (TEST CASE, EXECUTION OR MENTAL CODE - WALK - THRU)
- SEARCH FOR LATENT (PREVIOUSLY UNRECOGNIZED) SIGNATURES OF THESE ALTERNATE EXPLANATIONS

**SOLUTION**

- EXACTLY "WHAT IS THE ROOT PROBLEM"?
- WHAT OTHER FACTORS CAUSE PROBLEM TO BE MANIFESTED?
- WHAT OTHER EFFECTS CAN THIS PROBLEM PRODUCE?
- IMPLICATIONS TO USER, AND AVAILABLE WORK-AROUNDS DETERMINED
- IMPACT TO CORRECT THE PROBLEM IN CODE DETERMINED

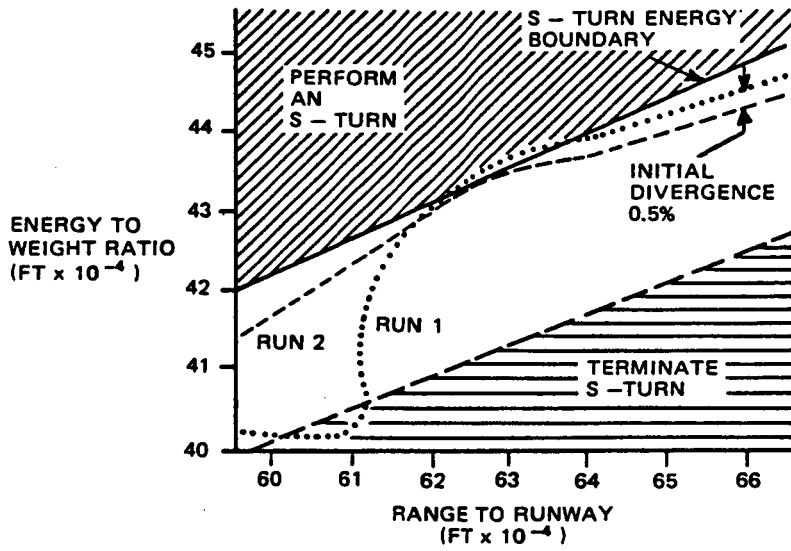
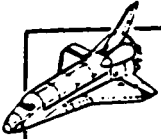

MAGNIFIED TIMELINE EXAMPLE



# CAUSE AND EFFECT GRAPHING EXAMPLE

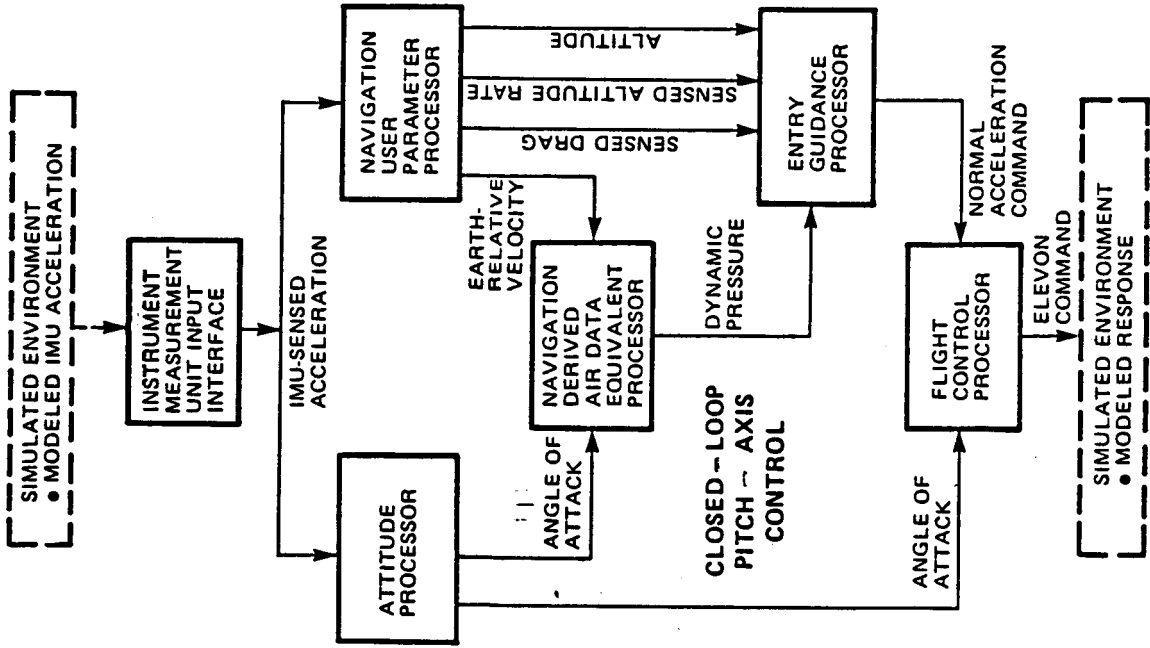
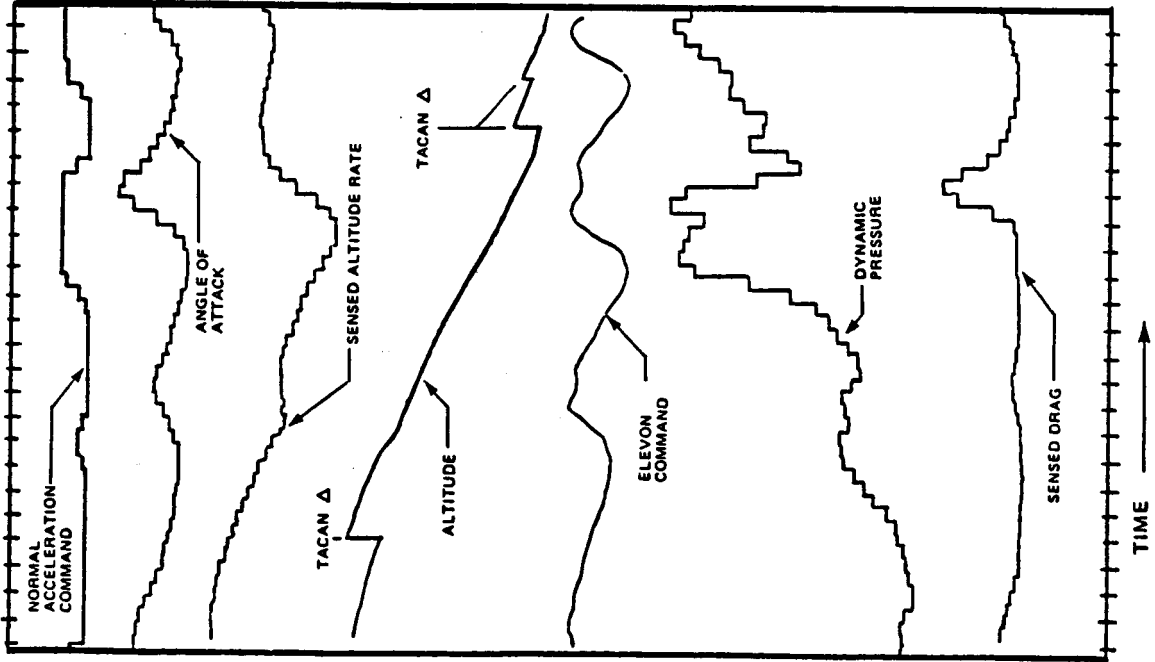

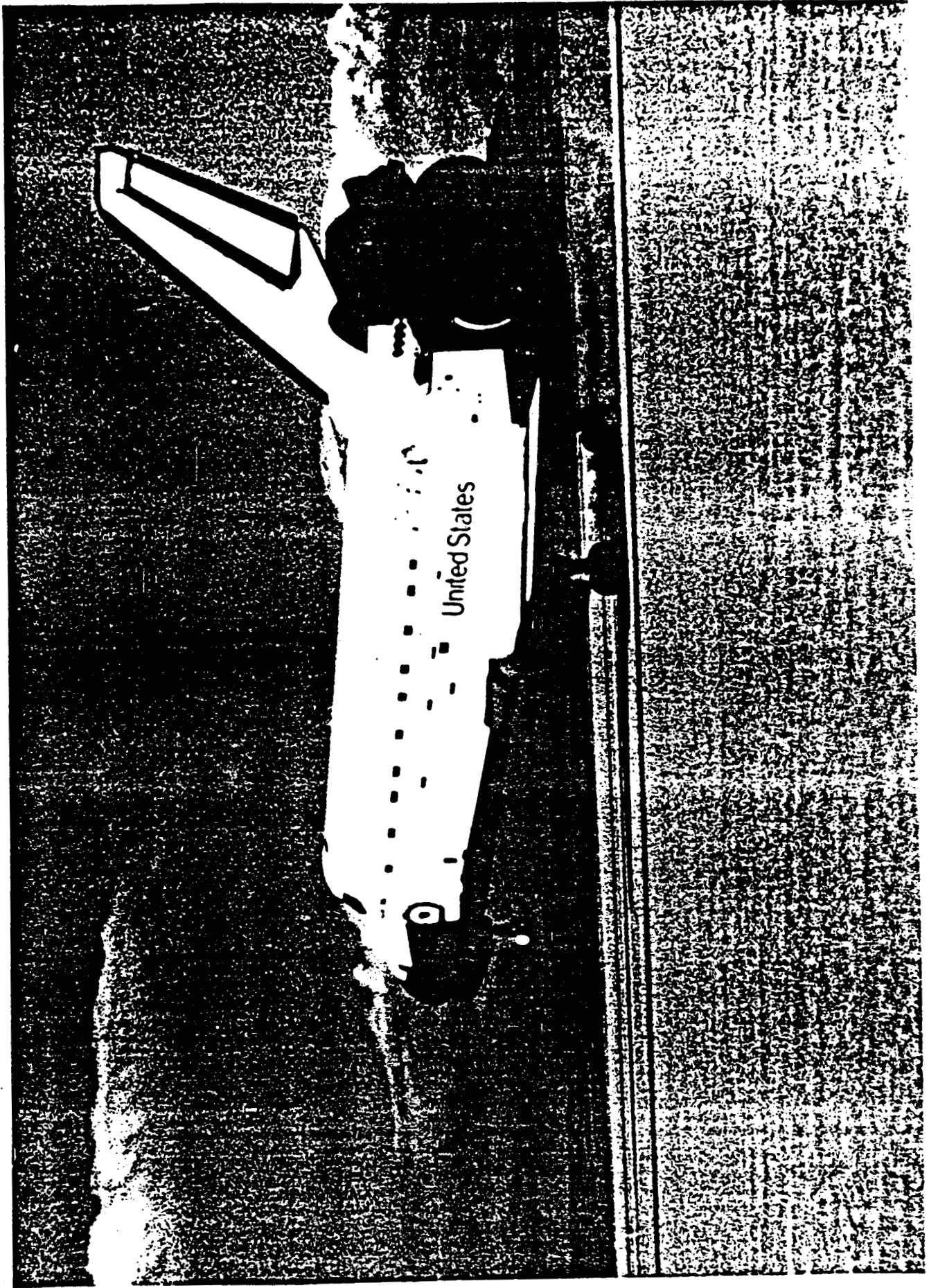

ORIGINAL PAGE IS  
OF POOR QUALITY



**SOFTWARE RELEASES  
AND  
RECONFIGURATION**

# SOFTWARE CRITICAL TO NASA SHUTTLE

## SOFTWARE RELEASES AND RECONFIGURATION

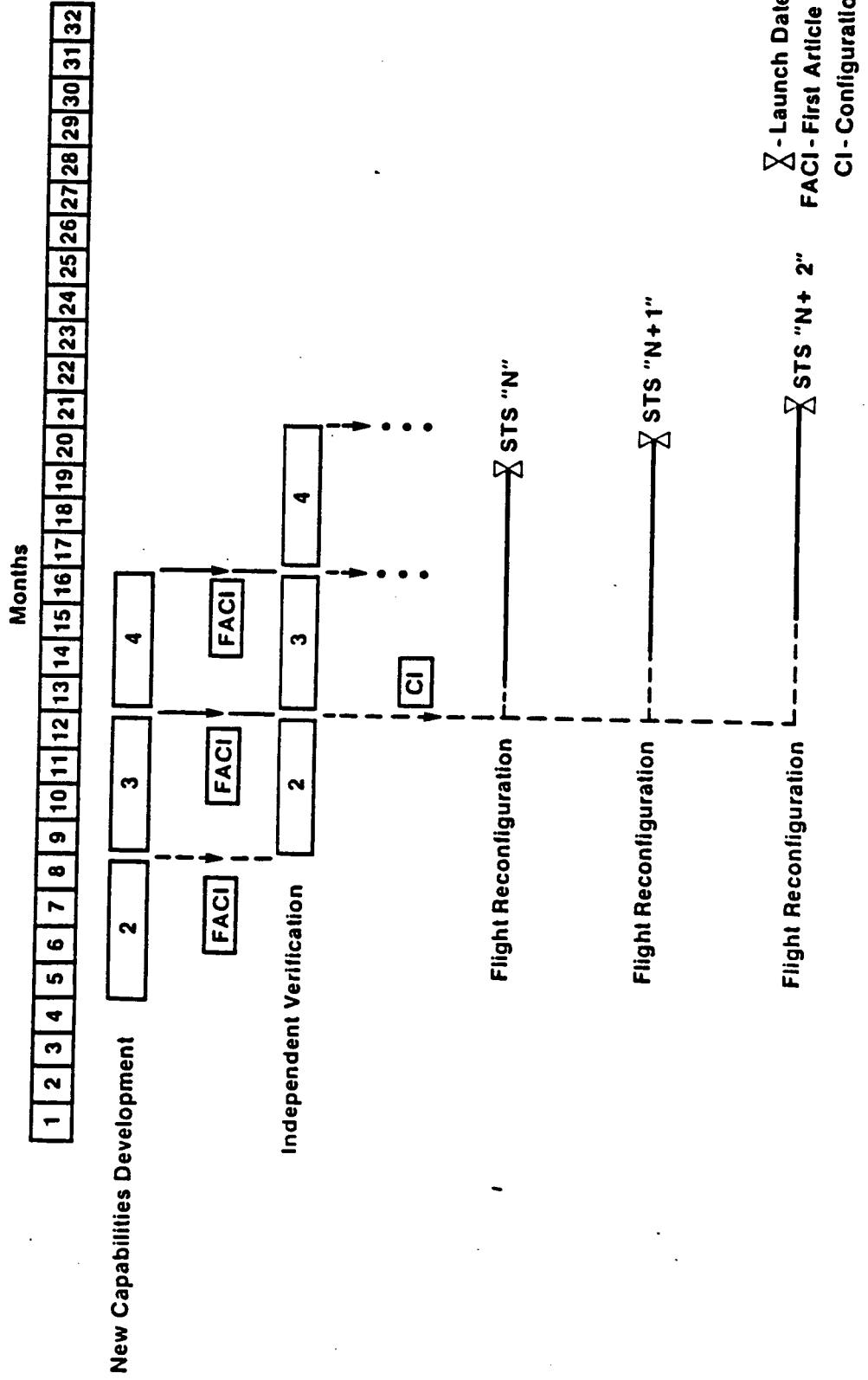

# RECONFIGURATION/CERTIFICATION

- **INDEPENDENT ORGANIZATION RESPONSIBLE FOR "TAILORING" FLIGHT SOFTWARE SYSTEMS TO SPECIFIC FLIGHTS**
- **HIGHLY AUTOMATED PROCESS**
- **FUNCTIONS**
  - RECEIVE ELECTRONIC REQUIREMENTS FROM NASA (WITHIN THE SPF)
  - MISSION PROFILE DATA (CALLED I-LOADS)
  - PAYLOAD AND VEHICLE SYSTEMS DATA (CALLED LEVEL-C DATA)
  - TELEMETRY CONFIGURATION DATA (CALLED DOWNLIST)
  - REQUIREMENTS READIED FOR APPLICATION TO BASE FLIGHT SOFTWARE SYSTEMS USING AUTOMATED PRE-PROCESSOR SYSTEMS
  - PROCESSED REQUIREMENT APPLIED TO BASE FLIGHT SOFTWARE SYSTEMS USING AUTOMATED BUILD AND
  - RECONFIGURED SYSTEM TESTING
    - AUTO SCORERS
    - DETAILED TESTING IN SPF
    - FLIGHT SIMULATIONS IN SPF
  - GENERATION AND QA OF DDELIVERABLES (TAPES, DOCUMENTATION, ETC.)
- **CURRENTLY PARALLEL RECONFIGURATION IS PERFORMED BY THE STS OPERATIONS CONTRACTOR AND BY IBM (CALLED CERTIFICATION)**

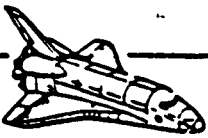

# NOMINAL (IDEAL) PASS DEVELOPMENT AND RECONFIGURATION ACTIVITY

## "OPERATIONAL INCREMENT PLAN/FLT-TO-FLT RECONFIGURATION PLAN"

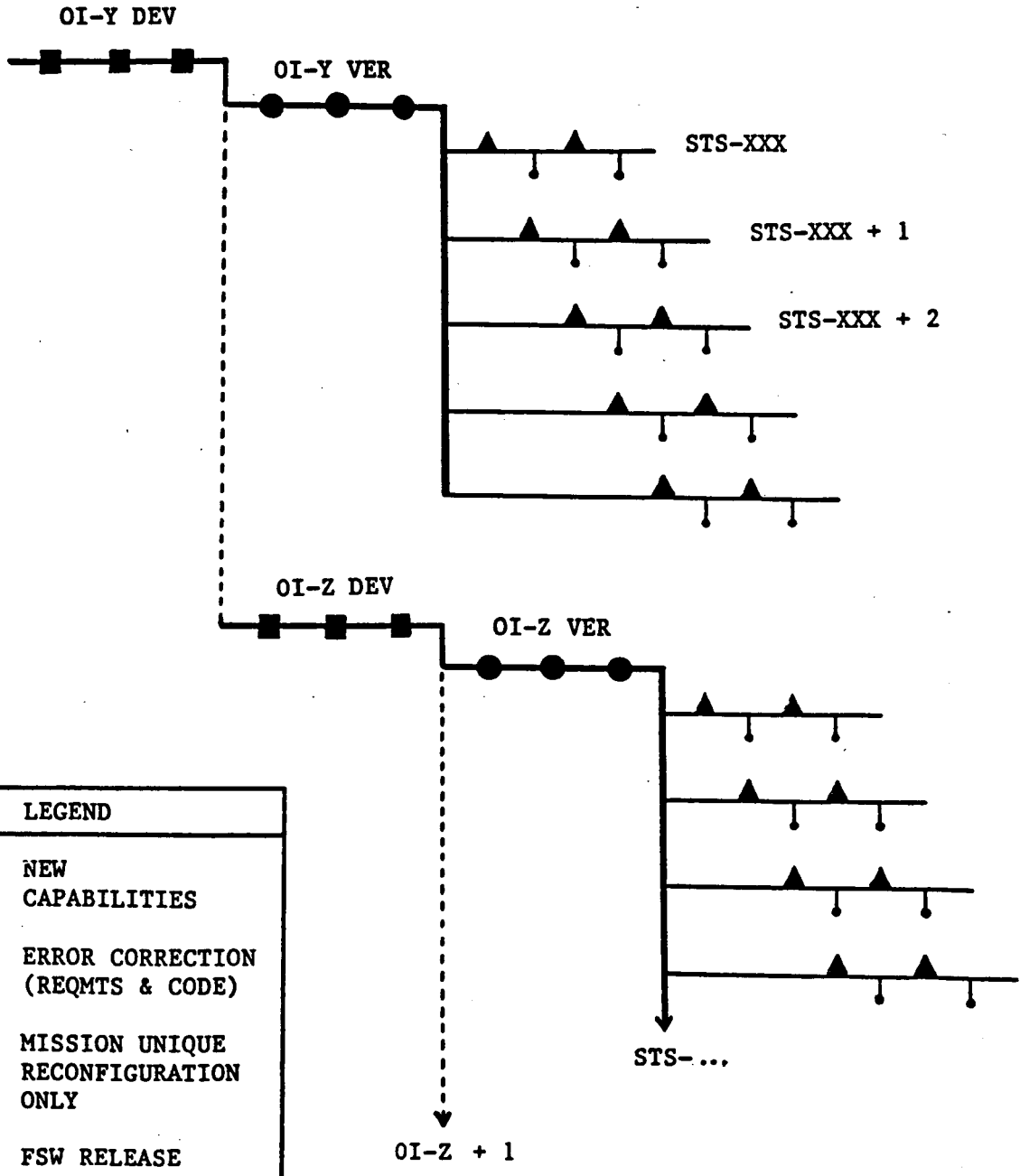

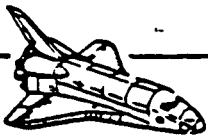

## ACTUAL PASS DEVELOPMENT AND RECONFIGURATION ACTIVITY

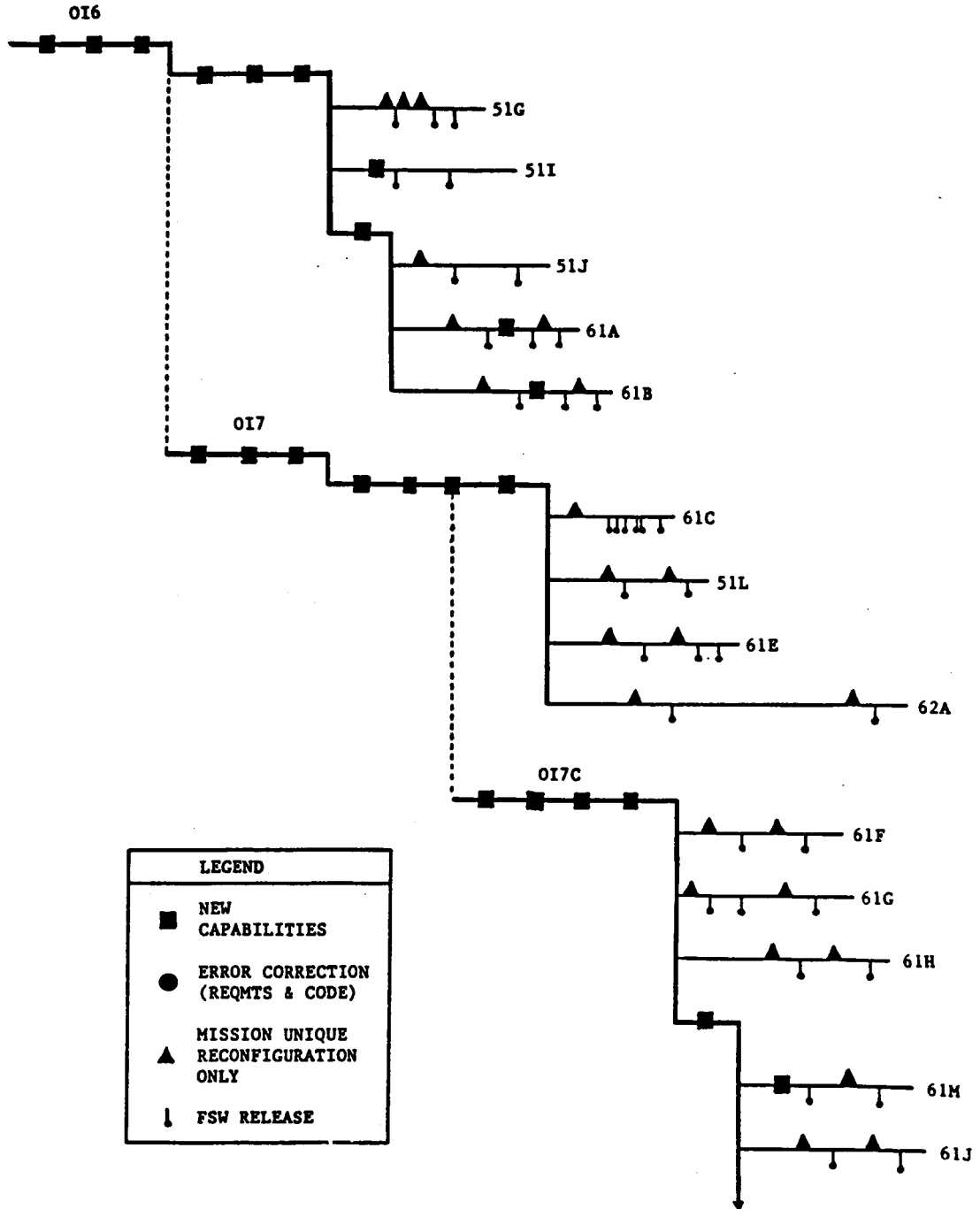

**APPENDIX A**

**QUALITY/PRODUCTIVITY  
PROGRAMS**

# **IBM QUALITY AND PRODUCTIVITY IMPROVEMENT PROGRAM**

---

## **DEFECT CAUSE ANALYSIS AND REMOVAL**

- **Inspections of Work Products Across the Process**
  - Requirements
  - Design
  - Code
  - Test
- **Categorization of Defects**
  - Data Collection and Retention
  - Analysis
- **Defect Trend Studies**
  - Escape Error Analysis
  - Process Studies Conducted By Those Involved

# IBM QUALITY AND PRODUCTIVITY IMPROVEMENT PROGRAM

## DEFECT REMOVAL CYCLE

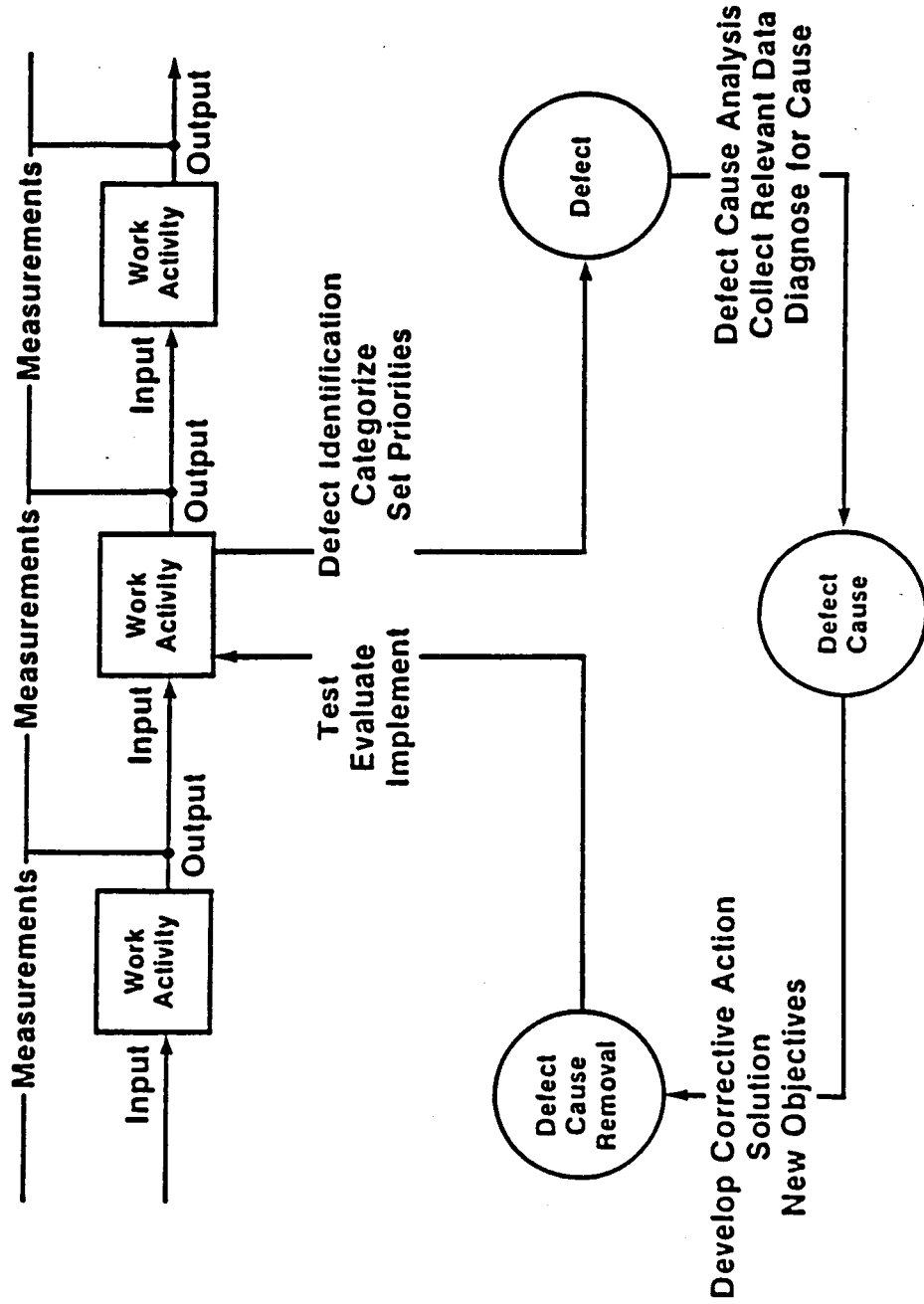



# DISCREPANCY ANALYSIS PROCESS

- EVERY DISCREPANCY IS FORMALLY REVIEWED TO DETERMINE WHETHER IT WAS MISSED BY ("ESCAPED") ANY "UPSTREAM" STEP IN THE DEVELOPMENT/VERIFICATION PROCESS
  - EACH AREA CONDUCTS INVESTIGATION FOR EACH OF ITS OWN "ESCAPES"
    - WHY PROBLEM MISSED
      - IF HUMAN ERROR, HOW TO DETECT/CORRECT
      - IF PROCESS ERROR, HOW TO CHANGE PROCESS
    - COULD OTHER OCCURRENCES OF SAME "ESCAPE" EXIST
      - IF SO, DEFINE SCOPE OF EXPOSURE
      - IF SO, DEFINE "AUDIT" TO IDENTIFY OTHER OCCURRENCE
  - QUALITY DATA RECORDED FOR FUTURE REFERENCE (CONFIGURATION MGMT DATA BASE)
    - CHANGE BEING MADE WHEN ERROR INTRODUCED
    - TYPE OF ERROR MADE
    - REASONS MISSED
    - SEVERITY OF ERROR IN FLIGHT IF NOT FIXED
  - DISCREPANCY HISTORY STUDIED FOR TRENDS/PATTERNS/COMMON TYPES
- PROCESS AND PROCEDURES ARE THEN AUGMENTED TO DEFENSE AGAINST FUTURE "ESCAPES" OF KNOWN PROBLEMS (AREA BY AREA)
- RESULTS OF ALL DISCREPANCY OVERSIGHT ANALYSES REVIEWED QUARTERLY WITH CONTRACTOR AND NASA MANAGEMENT
  - DISCREPANCY "ESCAPE/DETECTION" HISTORY PRESENTED (ANALYZED)



QUALITY MEASUREMENT DEFINITIONS

# IBM OBS QUALITY MEASUREMENT DEFINITIONS

- EARLY DETECTION % =  $\frac{\text{NUMBER OF MAJOR INSPECTION ERRORS}}{\text{NUMBER OF MAJOR INSPECTION ERRORS} + \text{VALID DRs}} \times 100$
- PROCESS ERROR RATE =  $\frac{\text{NUMBER OF VALID DRs DURING DEVELOPMENT CYCLE THROUGH SRR (OR CI*)}}{\text{THOUSAND NEW, CHANGED, OR DELETED SOURCE LINES OF CODE}}$
- PRODUCT ERROR RATE =  $\frac{\text{NUMBER OF VALID DRs POST COMPLETION (SRR OR CI*)}}{\text{THOUSAND NEW, CHANGED, OR DELETED SOURCE LINES OF CODE}}$
- RELEASED PRODUCT ERRORS = NUMBER OF VALID DRs AGAINST NEW OR CHANGED CODE WHICH WERE FOUND AFTER RELEASE AND ARE PRECEIVABLE BY USERS (SEV 1-3)

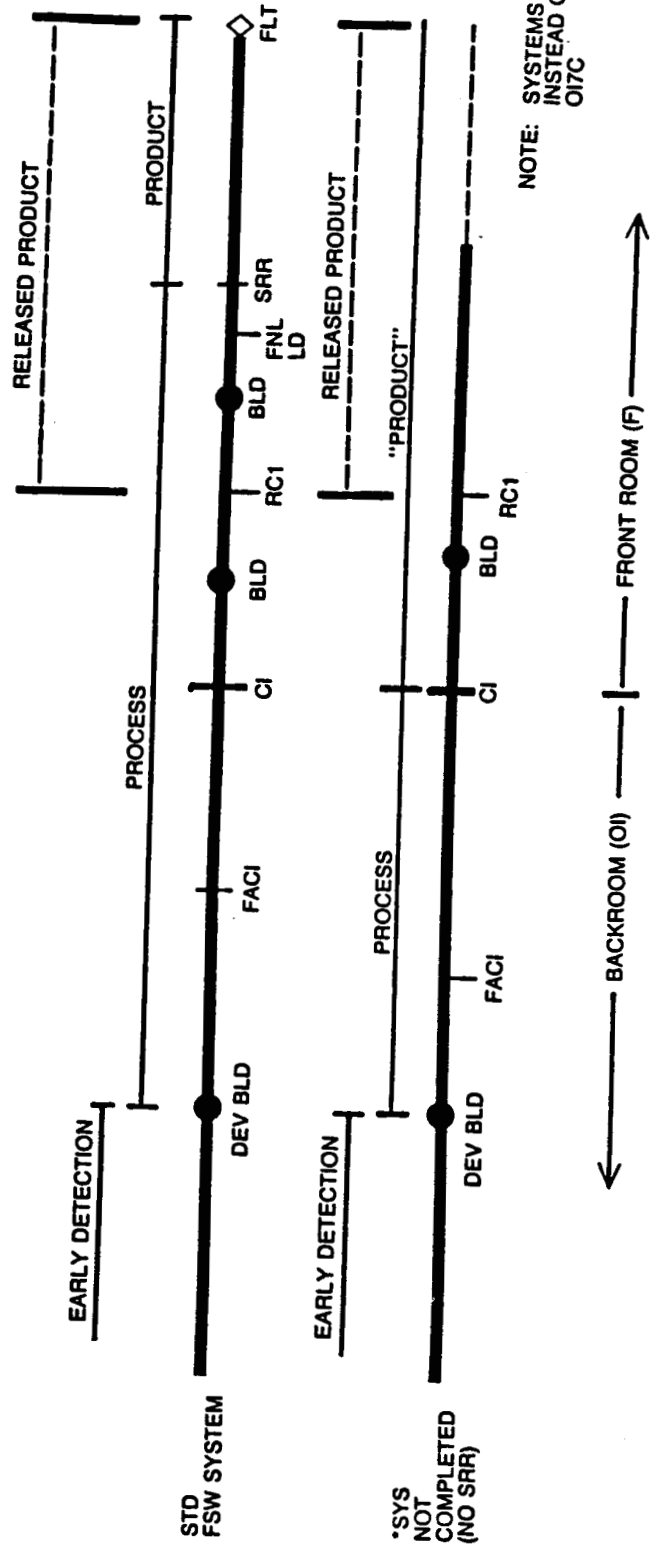

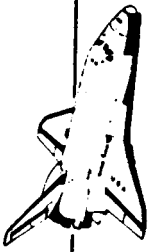

QUALITY MEASUREMENTS



EARLY DETECTION

-- WHAT PERCENT OF ALL ERRORS MADE WERE FOUND AND ELIMINATED BEFORE BEING IMPLEMENTED INTO THE FSW?

# EARLY DETECTION

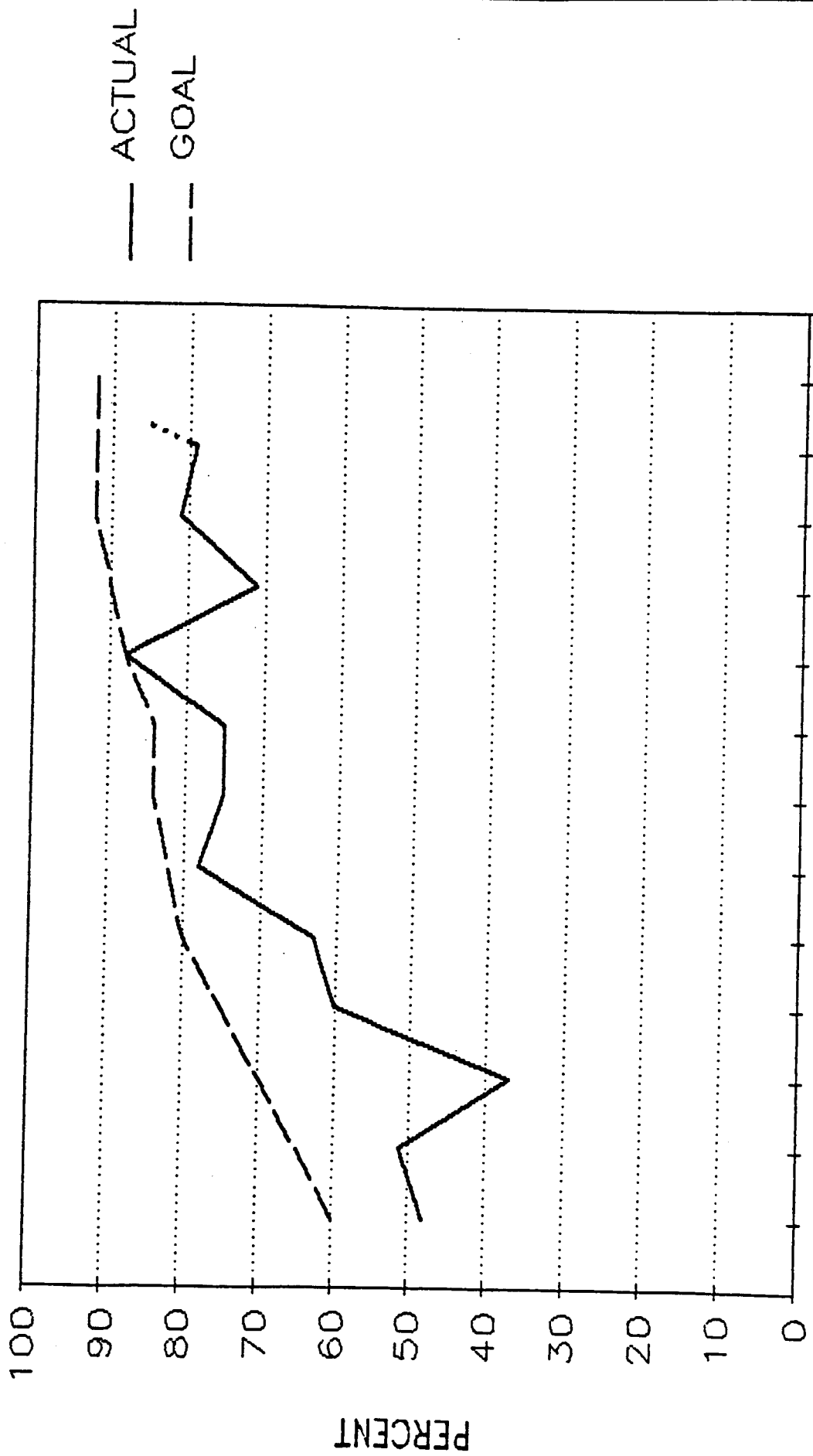

OI1 OI3 OI5 OI7 OI9 OI11 OI8B  
OI2 OI4 OI6 OI7C OI10 OI8A  
ONBOARD FLIGHT SOFTWARE RELEASES



PROCESS ERROR RATE

-- HOW MANY ERRORS WERE MADE IN THE FSW BUT WERE FOUND BEFORE FLIGHT?

# PROCESS ERROR RATE

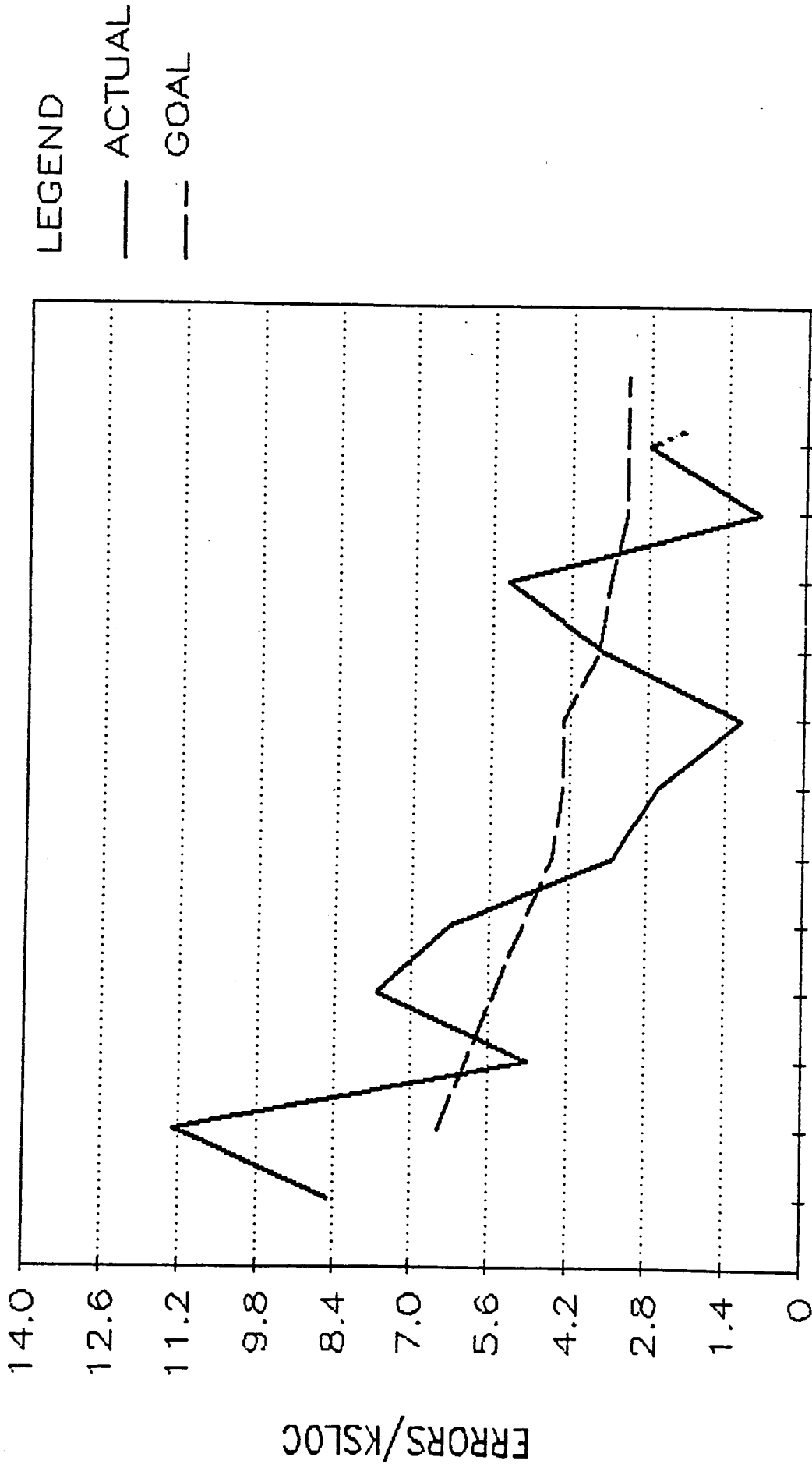

O101 O103 O105 O107 O109 O111 O18B  
O102 O104 O106 O17C O110 O18A  
ONBOARD FLIGHT SOFTWARE RELEASES



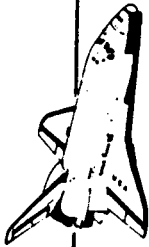

PRODUCT ERROR RATE

-- HOW MANY ERRORS DID OUR PROCESS MISS?

# PRODUCT ERROR RATE

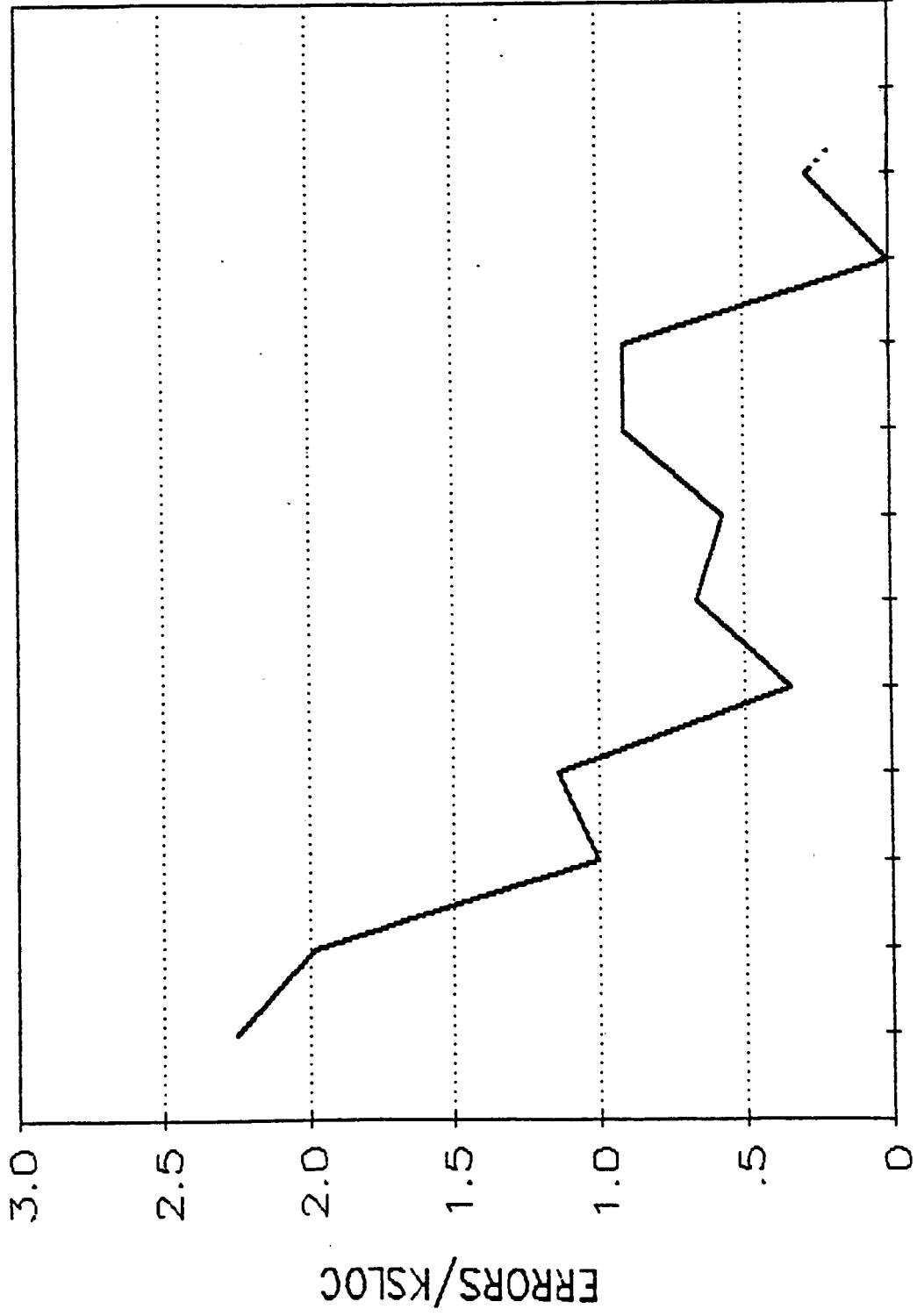

O101 O103 O105 O107 O109 O111  
O102 O104 O106 O17C O110 O18A  
ONBOARD FLIGHT SOFTWARE RELEASES

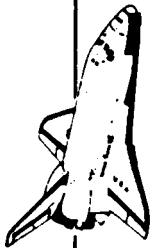

'RELEASED' PRODUCT ERRORS

-- A MEASURE OF CUSTOMER SATISFACTION

# TOTAL CLASS 1 RELEASED PRODUCT ERRORS

AS OF 7/7/87

Not Including 2 New DRs Found Against Pre-O13 FSW Since 3/87

DR COUNT  
 OEXDAP  
 NEW  
 PREV

ORIGINAL PAGE IS  
 OF POOR QUALITY

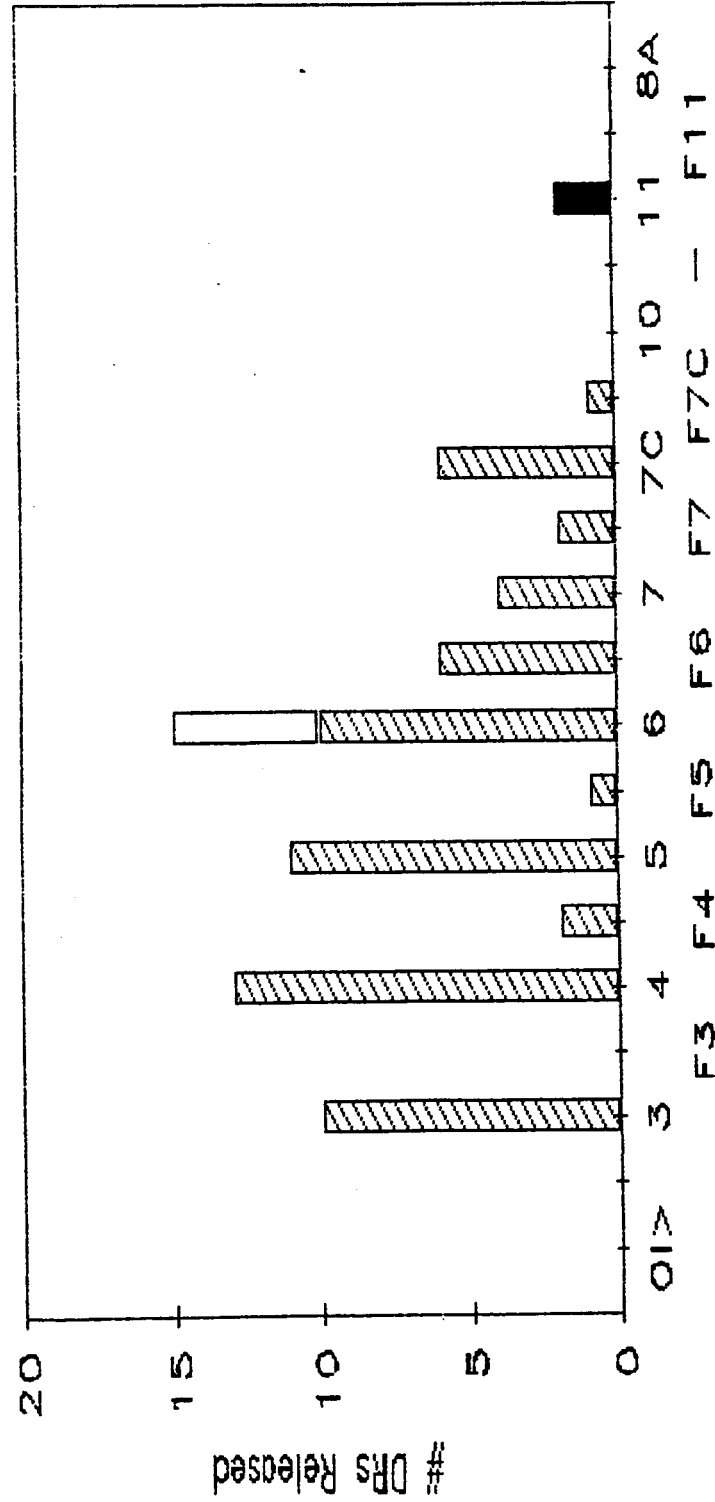

Software System Released

Fn Denotes Class 1 DRs in Frontroom for OIn Specified to Left.

# TOTAL CLASS 1 RELEASED PRODUCT ERRORS

AS OF 7/7/87

## SEVERITY DISTRIBUTION

Not Including 2 New DRs Found Against Pre-013 FSW Since 3/87

DR COUNT  
 SEV 3  
 SEV 2  
 SEV 1

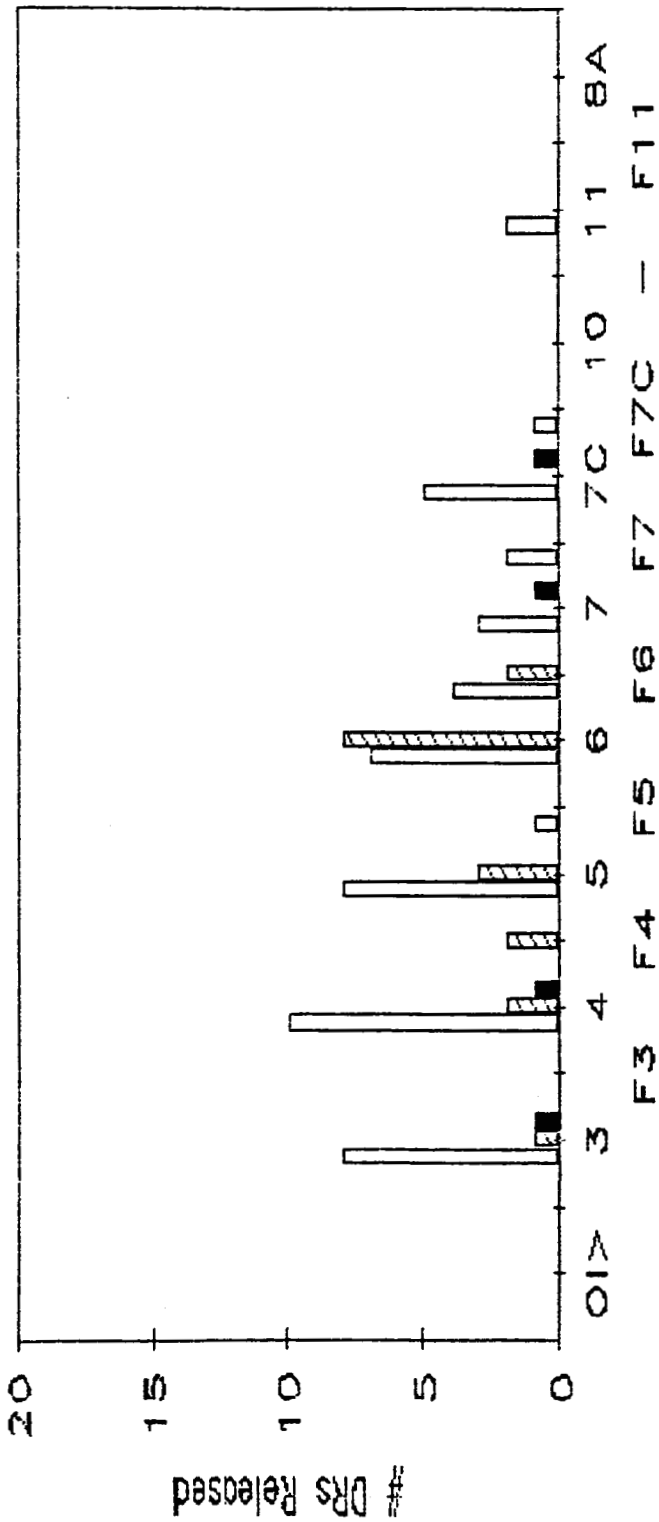

ORIGINAL PAGE IS  
 OF POOR QUALITY

Software System Released

Fn Denotes Class 1 DRs in Frontroom for Oln Specified to Left.

# SOFTWARE QUALITY AND PRODUCTIVITY MEASUREMENTS

## RECONFIGURATION ERRORS PER RELEASED SYSTEM

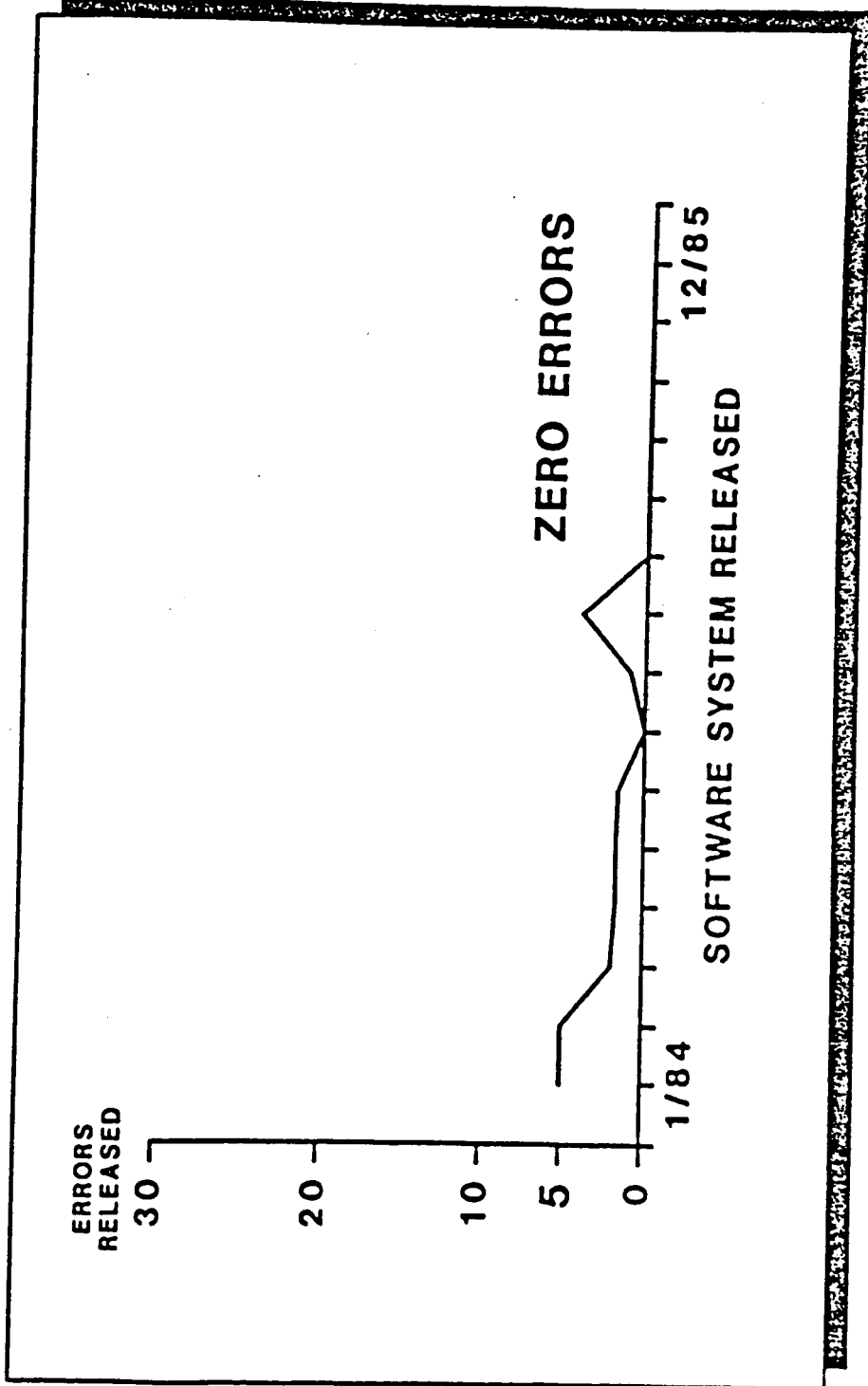

# SOFTWARE QUALITY AND PRODUCTIVITY MEASUREMENTS

## AUTOMATED SOFTWARE TOOLS AND PROCESS IMPROVEMENTS IN THE RECONFIGURATION PROCESS

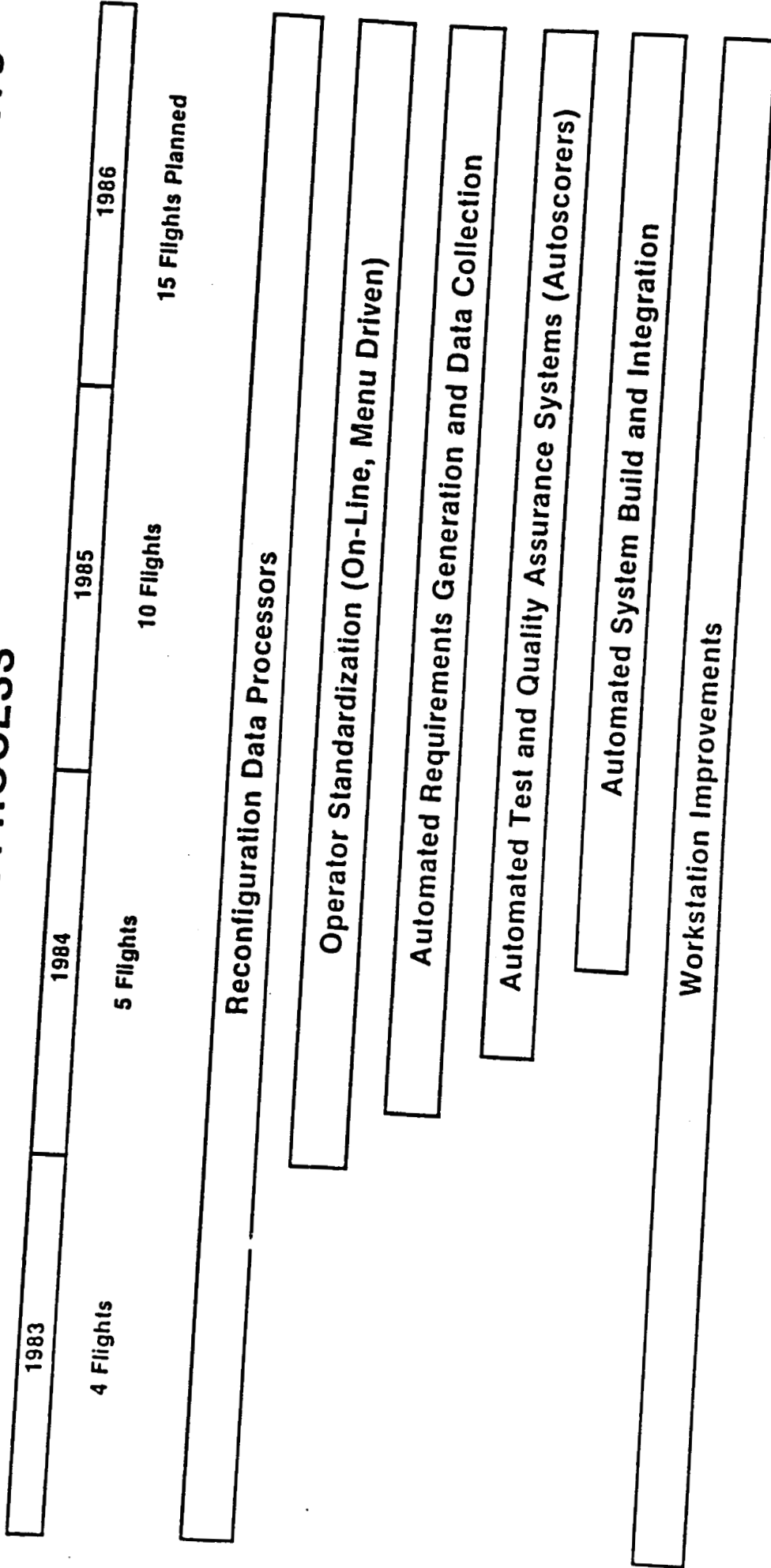

# SOFTWARE QUALITY AND PRODUCTIVITY MEASUREMENTS

## ONBOARD SHUTTLE SOFTWARE RECONFIGURATION PRODUCTIVITY IMPROVEMENTS

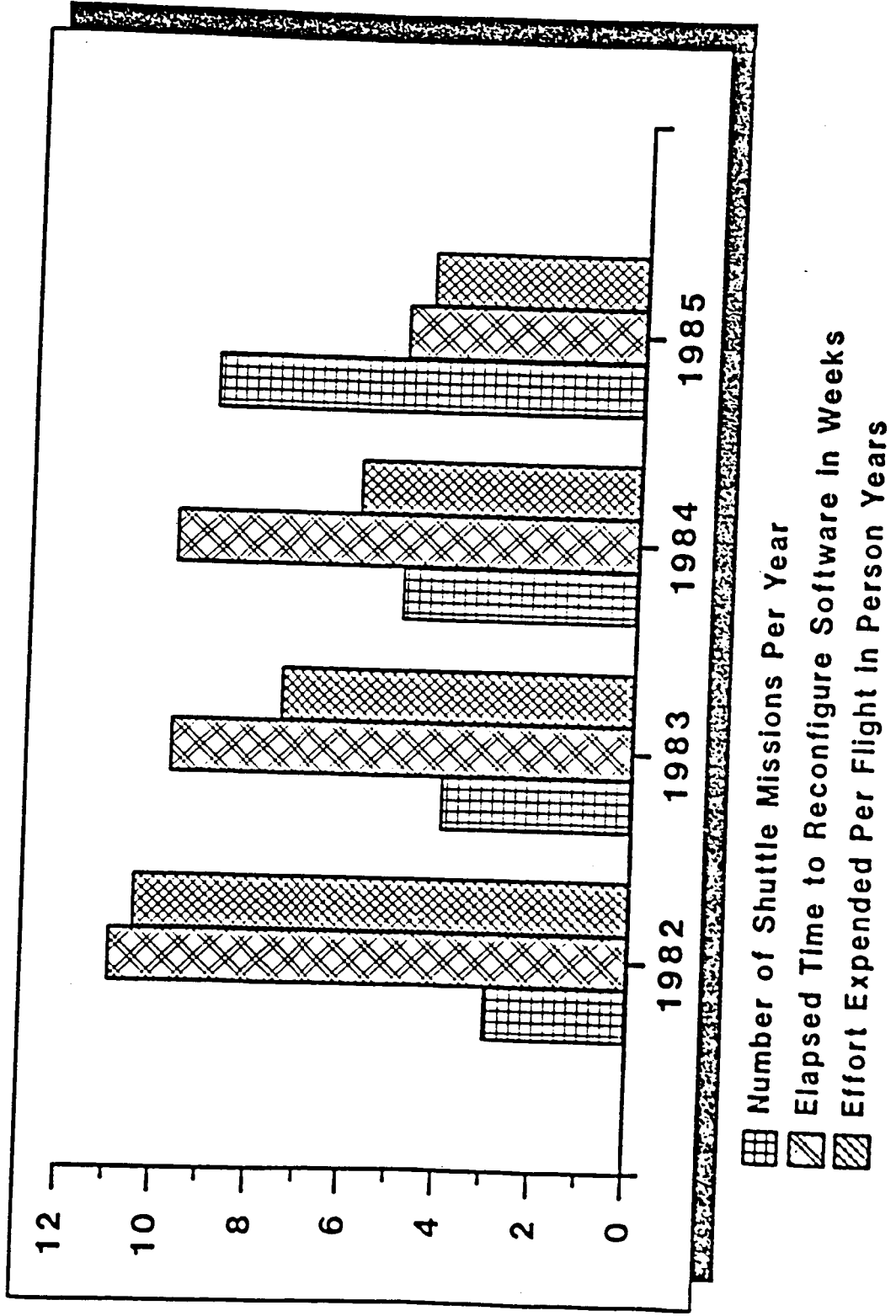



# SOFTWARE QUALITY AND PRODUCTIVITY MEASUREMENTS

## SHUTTLE SOFTWARE RELATIVE QUALITY IMPROVEMENTS

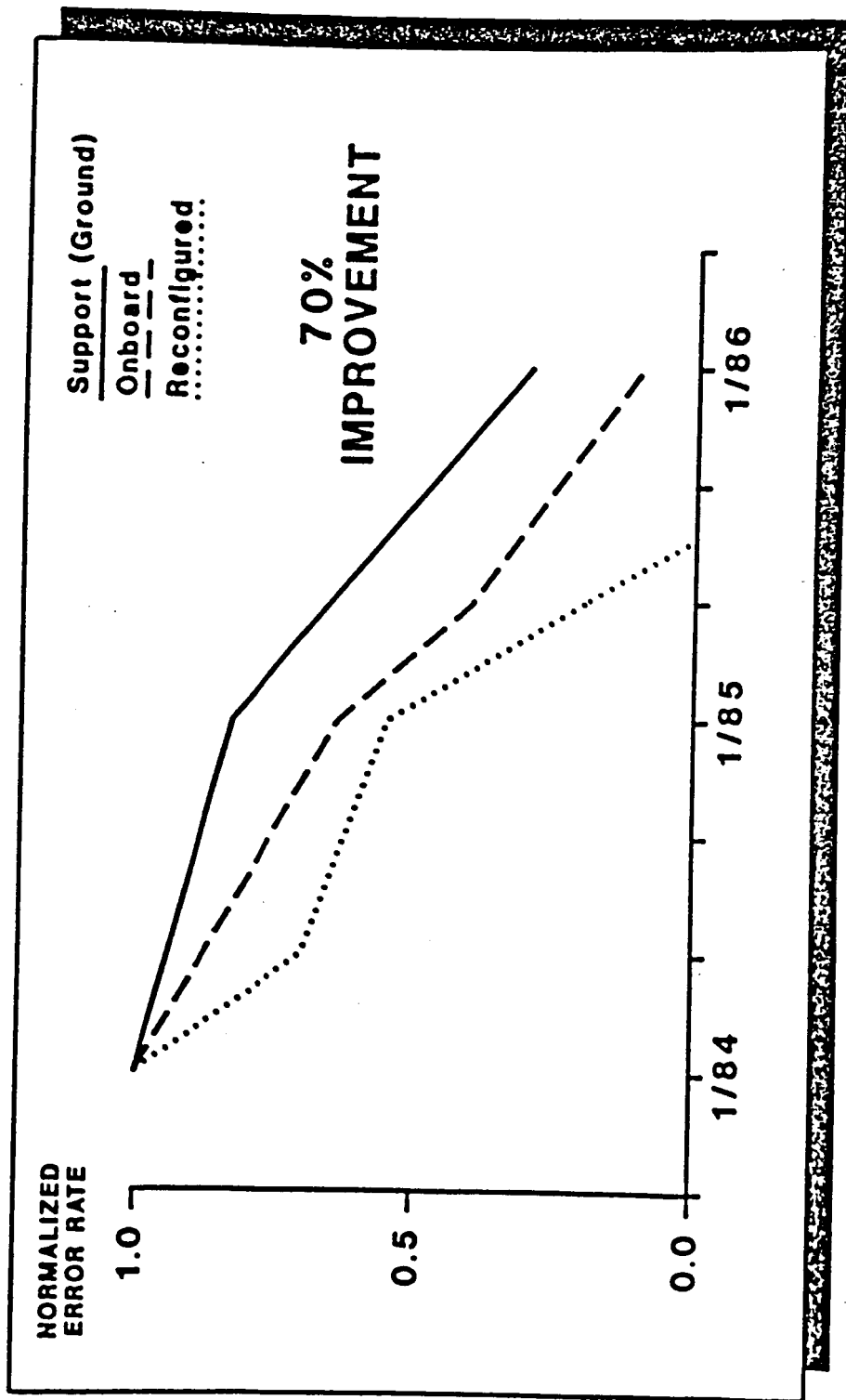

# SOFTWARE QUALITY AND PRODUCTIVITY MEASUREMENTS

SOFTWARE QUALITY IS AN IBM FSD STRENGTH

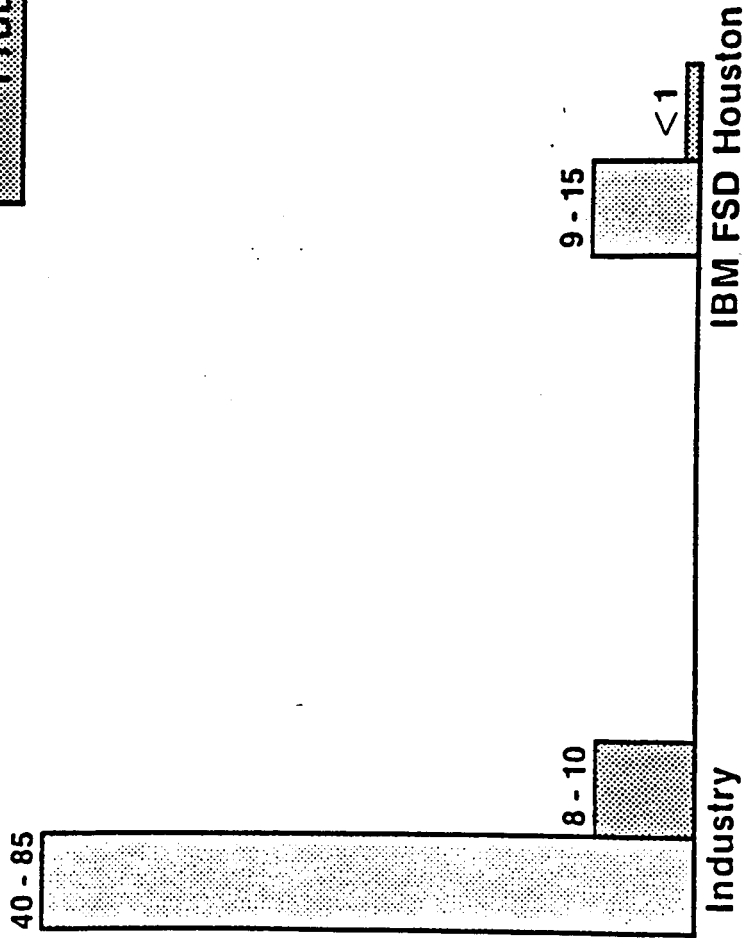
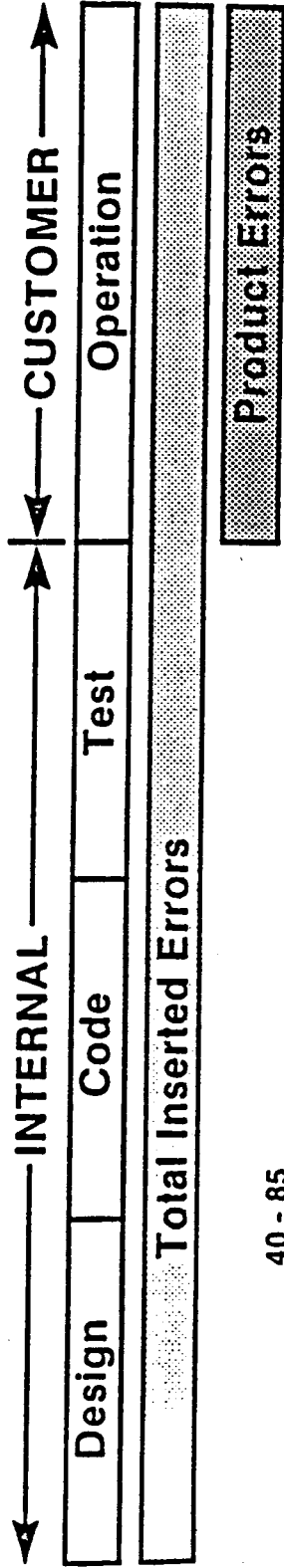

# **SOFTWARE QUALITY AND PRODUCTIVITY MEASUREMENTS**

- **Onboard Shuttle Software Quality Measurements Show Significant Improvement**
- **Onboard Shuttle Software Quality Among Highest in the Industry**
- **Shuttle Software Reconfiguration Productivity Increased Over 50%**
- **Onboard Shuttle Software Achievements Result From Commitment to Zero Errors**

**APPENDIX B**

**SOFTWARE DEVELOPMENT/PRODUCTION FACILITIES**

# SOFTWARE CRITICAL TO NASA SHUTTLE

## SOFTWARE DEVELOPMENT AND PRODUCTION FACILITY

- Mainframe Host Computers, Extensive Direct Access Disk Storage, Shuttle General Purpose Computers And Interfaces Necessary for Testing
- Access Via Terminals for Software Developers and NASA Community
- Software Consists of All Tools Necessary to Develop And Reconfigure the Software
  - Application Tools
  - Shuttle Simulator
  - Flight Software
  - Configuration Management Data Base
- Configuration Management Data Base is the Repository for All Project Control and Descriptive Information

# SOFTWARE CRITICAL TO NASA SHUTTLE

## ONBOARD SHUTTLE SOFTWARE DEVELOPMENT

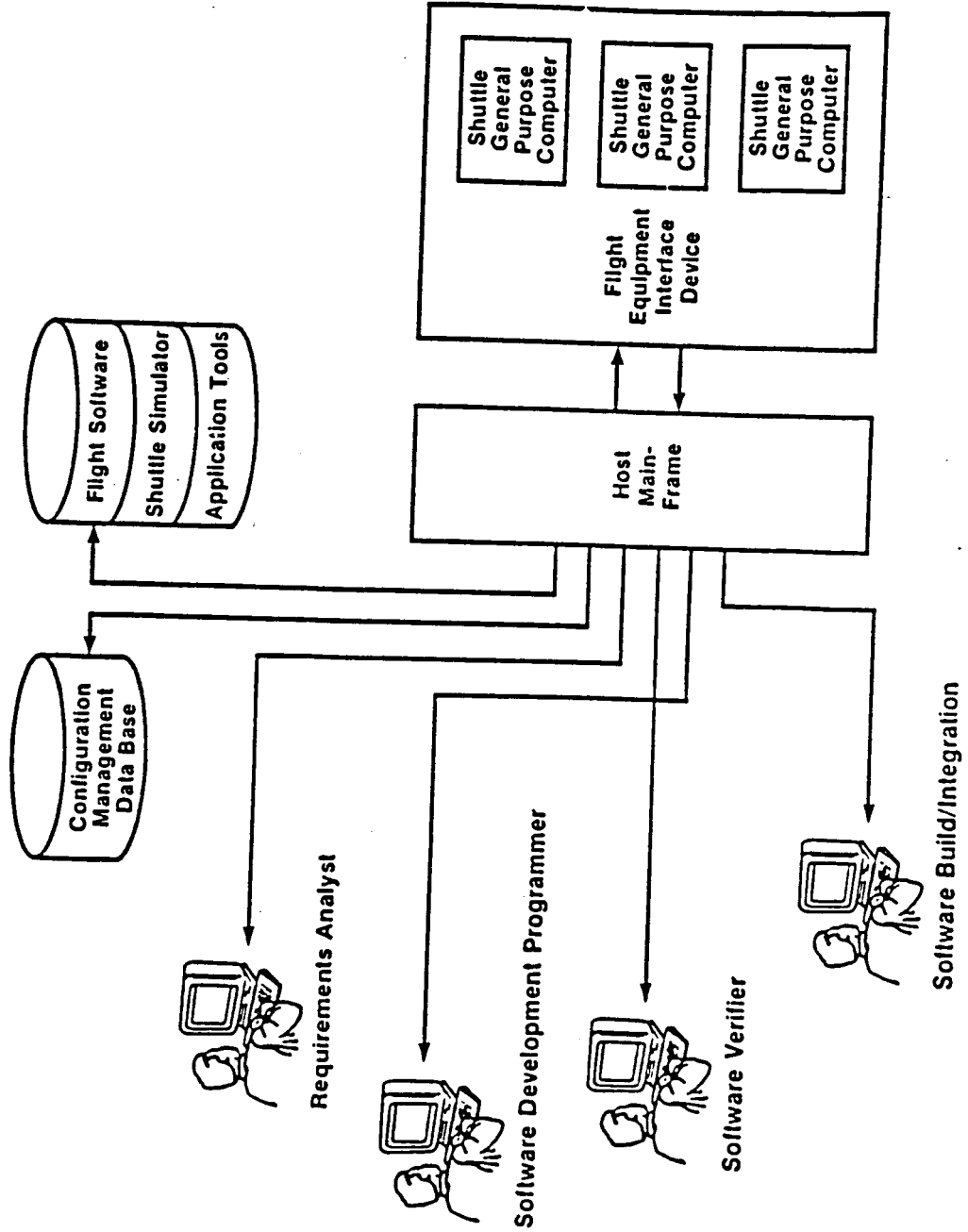

# SOFTWARE DEVELOPMENT/PRODUCTION FACILITY FLIGHT SIMULATOR

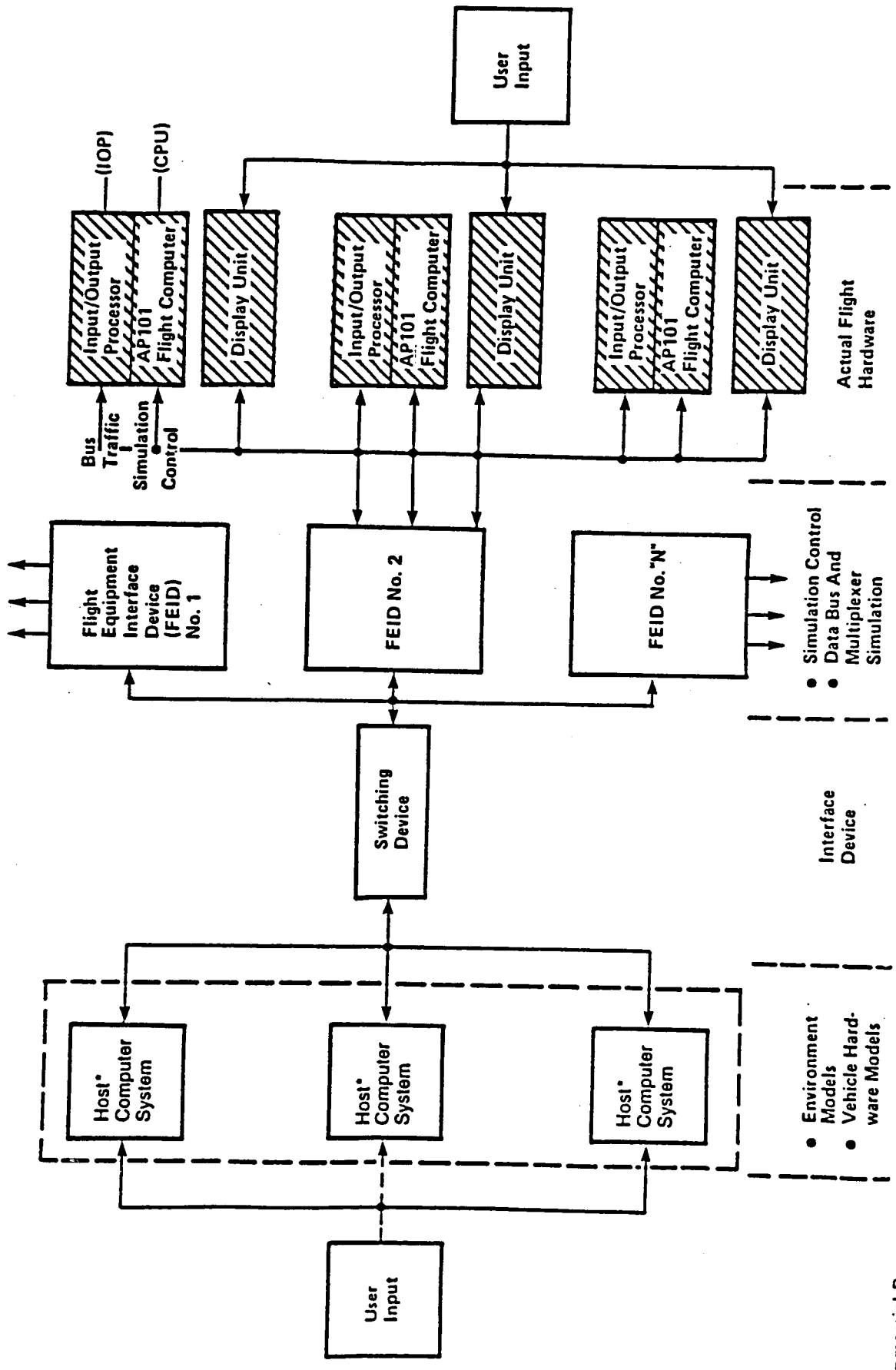
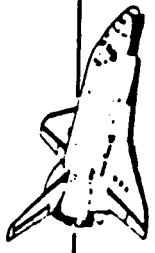

\* Commercial Processors

SPACE SHUTTLE PROGRAMS

APPENDIX C

ACRONYMS



## ACRONYMS

BCLMAKER	BUILD CONTROL LIST MANAGER
BFS	BACKUP FLIGHT SYSTEM
BFSPLP	BFS PAYLOAD PREPROCESSOR
CCB	CONFIGURATION CONTROL BOARD
CI	CONFIGURATION INSPECTION
CIP	CLASS 1 INTEGRATION PLAN
CITE	CARGO INTEGRATION TEST EQUIPMENT
CLASS 1	FSW CAPABILITY UPDATE
CMC	CONFIGURATION MANAGEMENT & CONTROL
CMDB	CONFIGURATION MANAGEMENT DATA BASE
CPU	CENTRAL PROCESSING UNIT
CR	CHANGE REQUEST (Used Interchangeably With SCR)
CSECT	CONTROL SECTION
DBA	DATA BASE ADMINISTRATOR
DCCB	DATA CONFIGURATION CONTROL BOARD
DCR	DATA CHANGE REQUESTS
DDRB	DEVELOPMENT DISCREPANCY REVIEW BOARD
DL OR D/L	DOWNLIST
DLP	DOWNLIST PREPROCESSOR
DPSD	DATA PROCESSING SYSTEM DIVISION
DR	DISCREPANCY REPORT FOR FSW
DSN	DATA SET NAME
FACI	FIRST ARTICLE CONFIGURATION INSPECTION
FCCB	FACILITIES CHANGE CONTROL BOARD
FEID	FLIGHT EQUIPMENT INTERFACE DEVICE

## ACRONYMS

FLPS	FLIGHT LOAD PREPARATION SYSTEM
FRF	FLIGHT READINESS FIRING
FSW	FLIGHT SOFTWARE
GFE	GOVERNMENT FURNISHED EQUIPMENT/INFORMATION
GMEM	GENERAL MEMORY READ/WRITE PROCEDURE
GTL	GENERIC TRAINING LOAD
HDW	HARDWARE
HSM	HIERARCHICAL STORAGE MANAGEMENT
IBCB	INTEGRATED BASELINE CONTROL BOARD
IBM	INTERNATIONAL BUSINESS MACHINES
IDRB	INTEGRATED DISCREPANCY REVIEW BOARD
IDS	ILOAD DATA SET
IL OR I/L	INITIALIZATION LOAD
IMRB	INTERIM MASTER RECONFIGURATION BASE
IMS	INFORMATION MANAGEMENT SYSTEM
JES	JOB ENTRY SUBSYSTEM
JSC	JOHNSON SPACE CENTER
KSC	KENNEDY SPACE CENTER
L6	LEVEL 6 DETAIL FUNCTIONAL TESTING
L7	LEVEL 7 CAPABILITIES PERFORMANCE TESTING
L8	LEVEL 8 RECONFIGURATION PERFORMANCE TESTING
MAST	MEASUREMENT AND STIMULUS DATA BASE
MCC	MISSION CONTROL CENTER
MDBINIT	MEMBER DATABASE INITIALIZATION
MIP	MASS MEMORY INTEGRATION PLAN
MM	MASS MEMORY
MMI	MASS MEMORY IMAGE

## ACRONYMS

MMU	MASS MEMORY UNIT
MOCRB	MISSION OPERATIONS CHANGE REVIEW BOARD
MOD	MISSION OPERATIONS DIRECTORATE
MODRB	MISSION OPERATIONS DISCREPANCY REVIEW BOARD
MRAS	MAINTENANCE RELEASE AUTHORIZATION
MRB	MASTER RECONFIGURATION BASE
MSFC	MARSHALL SPACE FLIGHT CENTER
MVS	MULTIPLE VIRTUAL STORAGE
OASCB	ORBITER AVIONICS SOFTWARE CONTROL BOARD
OI	OPERATIONAL INCREMENT (BASE FSW SYSTEM)
ORG	ORGANIZATION
OSDR	OPERATION SHUTTLE DATA RECONFIGURATION
PASS	PRIMARY AVIONICS SOFTWARE SUBSYSTEM
PCO	PATCH CUT-OFF
PCR	PROGRAM CHANGE REQUEST
PRCB	PROGRAM REQUIREMENTS CONTROL BOARD
PRN	PROGRAM RELEASE NOTICE
PSCR	PRODUCTION SOFTWARE CHANGE REQUEST
PSDR	PRODUCTION SOFTWARE DISCREPANCY REPORT
PSF	PARAMETER SPECIFICATION FILE
R & E	RESEARCH AND ENGINEERING
RASS	RELEASE AUTHORIZATION SIGNATURE SHEET
RCV	RECEIVING
RECON	RECONFIGURATION (FLIGHT-TO-FLIGHT)
RELAUTH	RELEASE AUTHORIZATION
RI/D	ROCKWELL INTERNATIONAL/DOWNEY
RM	ROOM (AS IN FRONTROOM OR BACKROOM)

## ACRONYMS

RSD	RECONFIGURATION SYSTEMS DEVELOPMENT
RSOC	ROCKWELL SHUTTLE OPERATIONS COMPANY
RT & O	RECON TEST & OPERATIONS CONTROL BOARD
SAS	SOFTWARE APPROVAL SHEET
SCCB	SOFTWARE CONFIGURATION CONTROL BOARD
SCR	SOFTWARE (CAPABILITY) CHANGE REQUEST
SDF	SOFTWARE DEVELOPMENT FACILITY
SM	1. SYSTEM MANAGEMENT AS IN "SM FSW" 2. SUBMIT TRANSACTION AS IN "SUBMIT POOL ELEMENT VIA SM TRANSACTIONS IN IVMS"
SMP	SYSTEMS MANAGEMENT PREPROCESSOR
SPF	SOFTWARE PRODUCTION FACILITY
SPIF	SHUTTLE PAYLOAD INTEGRATION FACILITY
SPT	SUPPORT
SRC	SOURCE
SRR	SOFTWARE READINESS REVIEW
SSD	SPACECRAFT SOFTWARE DIVISION
SSDR	SUPPORT SOFTWARE DISCREPANCY REPORT
STAR	SPACE TRANSPORTATION AUTOMATED RECONFIGURATION
STS	SPACE TRANSPORTATION SYSTEM
STSOC	SPACE TRANSPORTATION SYSTEM OPERATIONS CONTRACT
SW OR S/W	SOFTWARE
SYNVAT	SYSTEM NAME VALIDATION TABLES FOR SMDB
T & O	TEST & OPERATIONS
TCT	TEST COORDINATION TEAM
TR	TRANSMITTAL RELEASE
UAT	USER ACCEPTANCE TEST

ACRONYMS

UPF	UNIVERSAL PATCH FORMAT
VCS	VEHICLE/CARGO SYSTEMS
VLS	VANDENBERG LAUNCH SITE



## APPENDIX D

# EXTERNAL EVALUATIONS OF IBM PROCESS

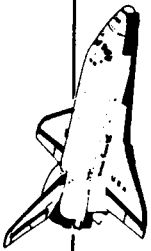

## EXTERNAL EVALUATIONS OF IBM PROCESS

- **NASA EXCELLENCE AWARD FOR  
QUALITY AND PRODUCTIVITY RECIPIENT**

1986

**IBM Federal Systems Division**  
Houston, Texas

- **"To summarize then, the computer  
software checking system and  
attitude is of highest quality."**

**Dr. Richard Feynman**  
**Report of the Presidential  
Commission on the Space  
Shuttle Challenger Accident**