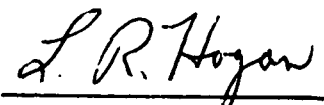

SD 76-SA-0028-1
CR-144966

SPACELAB USER IMPLEMENTATION ASSESSMENT STUDY
(SOFTWARE REQUIREMENTS ANALYSIS)

VOLUME I
EXECUTIVE SUMMARY

A handwritten signature in cursive script, reading "L. R. Hogan", is positioned above a horizontal line.

L. R. Hogan
Study Manager

Prepared under Contract NAS1-12933
for
Langley Research Center
National Aeronautics & Space Administration

Page intentionally left blank



FOREWORD

The Software Requirements Analysis Study was conducted to definitize requirements and implementation approaches for the Advanced Technology Laboratory (ATL) Spacelab payloads of Langley Research Center. The effort consisted of an expansion and in-depth analysis of ATL software requirements identified in the basic study, *Spacelab User Implementation Assessment Study*. The study was conducted by the Space Division of Rockwell International Corporation under Contract NAS1-12933. Mr. F. O. Allamby was the technical manager for the Langley Research Center.

The final report consists of two volumes: an executive summary, and a technical report of all the analyses/trades conducted during the course of the study. A succinct summary of the study objectives, principal conclusions, tradeoffs, recommendations, and future related efforts is presented in the executive summary. The technical report includes the development of the study data base, synthesis of implementation approaches for software required by both mandatory on-board computer services and command/control functions, and identification and implementation of software for ground processing activities.

Page intentionally left blank



CONTENTS

Section		Page
1.0	INTRODUCTION AND SUMMARY	1-1
1.1	STUDY OVERVIEW	1-1
1.2	SYNOPSIS OF STUDY RESULTS	1-3
2.0	SIGNIFICANT STUDY RESULTS	2-1
2.1	ON-BOARD PROCESSING REQUIREMENTS DATA BASE	2-1
2.2	ON-BOARD COMPUTER SERVICES	2-2
2.3	ON-BOARD COMMAND AND CONTROL	2-10
2.4	GROUND PROCESSING REQUIREMENTS DATA BASE	2-17
2.5	GROUND PROCESSING IMPLEMENTATION COST FACTORS	2-21
2.6	PROGRAMMATIC EVALUATION	2-26
2.7	PALLET-ONLY CONFIGURATION SPECIAL CONSIDERATIONS	2-35
3.0	PROGRAMMATIC SOFTWARE-RELATED RECOMMENDATIONS	3-1
4.0	RELATED FUTURE EFFORT	4-1

Page intentionally left blank



ILLUSTRATIONS

Figure		Page
1.1-1	Study Approach	1-2
2.2-1	On-Board Processor Flight Hardware Definition	2-2
2.2-2	Software Development Approach	2-3
2.2-3	Experiment Flight Software Development	2-4
2.2-4	On-Board Processor Flight Hardware	2-6
2.2-5	Mini/Micro Processor Software Preparation/Validation	2-7
2.2-6	Programmatic Cost Evaluation	2-7
2.2-7	ATL Payload 3 On-Board Processing Requirements	2-8
2.2-8	STIL Function with Mini/Micro Processor Approach	2-9
2.3-1	Data Management Design Concept Comparison	2-10
2.3-2	ATL Experiment Panel Components	2-11
2.3-3	Comparison of Aerospace and Mil-STD Costs	2-11
2.3-4	Level III/II Integration Configuration (Typical)	2-12
2.3-5	Computer-Aided Hardware Cost Factors	2-13
2.3-6	Typical Measurement Display	2-13
2.3-7	Computer Display (Aided)	2-14
2.3-8	Automated Control Logic	2-15
2.3-9	Command/Control Concept Comparison (Per Experiment)	2-16
2.4-1	Optional Processing Documentation	2-18
2.4-2	Ground Processing Size Estimates	2-19
2.4-3	Ground Processing Software Availability (MSFC)	2-20
2.5-1	Interactive/Automatic (Batch) Concept	2-21
2.5-2	Ground Processing Tutorial Requirements	2-22
2.5-3	Remote Terminal Alternatives	2-24
2.6-1	Typical ATL Payload Hardware Complement	2-28
2.6-2	Software Programmatic Complement	2-28
2.6-3	Programmatic Costing Criteria	2-29
2.6-4	Cumulative Recurring Cost Summaries	2-33
2.7-1	AFD Panel Allocation for Orbiter Payloads	2-35

Page intentionally left blank



TABLES

Table		Page
2.1-1	ATL Experiment Definition and Payload Grouping . . .	2-1
2.4-1	Essential Computer-Supported Activities	2-17
2.5-1	Batch Processing Considerations	2-23
2.5-2	Implementation Cost Comparison	2-25
2.6-1	Man-Machine Interface Grouping	2-27
2.6-2	Program Cost Summary - Baseline ATL Traffic Model . . .	2-30
2.6-3	Program Cost Summary - 2 Flights/Year Limit	2-31
2.6-4	Program Cost Summary - 1 Flight/Year Limit	2-32
2.6-5	Contingency Evaluation	2-34
2.7-1	ATL Pallet-Only Payload-Required Hardwired Panel Space .	2-36
2.7-2	Cost Comparison of Command/Control Approaches for Reference Pallet-Only ATL Payload	2-37



1.0 INTRODUCTION AND SUMMARY

The tasks of the basic *Spacelab User Implementation Assessment Study (SUIAS)* definitized alternate integration and checkout approaches for ATL Spacelab payloads. One of the more significant factors in the processing cycle that would affect the cost and efficiency of the activities was the software required by the on-board and ground operations. Not only could software become a pacing item in the design, development, integration, and operations activities, it could also become a significant cost factor. Thus, this effort, the *Software Requirements Analysis Study (SRAS)* was conducted to establish requirements, assess alternate implementations, and identify programmatic costs of software and related hardware for the flight and ground operations associated with ATL Spacelab payloads. In this section, an overview of the study and a synopsis of the results and recommendations are presented.

1.1 STUDY OVERVIEW

STUDY OBJECTIVES

The primary objective of SRAS was to develop an integrated approach for the development, implementation, and utilization of all software that is required to efficiently/cost-effectively support ATL flight and ground operations. It was recognized that certain aspects of the operations would be mandatory computerized services; computerization of other aspects would be optional. Thus, the analyses were to encompass not only alternate computer utilization/implementations but trade studies/evaluations of the programmatic affects of non-computerized versus computerized approaches to the operations.

A principal criterion in the development of the ATL software definition was to maximize the autonomy of individual experiments and define each experiment system as self-contained as practical. The intent of this criterion was to maximize the flexibility and PI control in both flight and ground operations by avoiding the synthesis of interdependent experiment-to-experiment, experiment-to-Spacelab, or experiment-to-Orbiter hardware/software systems. Independence of experiment systems was a goal that would be limited only by factors externally imposed. For example, constrained Spacelab-Orbiter interfaces impose the requirement to integrate experiment *housekeeping* services such as telemetry, caution and warning, and annotation data within the control and data management subsystem (CDMS) of the Spacelab.

A second criterion in the development of the ATL software definition was to derive an approach to flight and ground operations that will enhance/promote the usability/accessibility of the ATL Spacelab to a broad/diverse spectrum of principal investigators. The selected approach must reflect direct access and involvement of the PI's in an understandable format. Admittedly, a limited degree of standardization in the techniques for PI participation is required. But this standardization will provide clear-unambiguous definition of PI responsibilities and greatly assist in avoiding interaction and interdependency between PI's and other program elements.

STUDY APPROACH

The approach used in SRAS is illustrated in Figure 1.1-1.

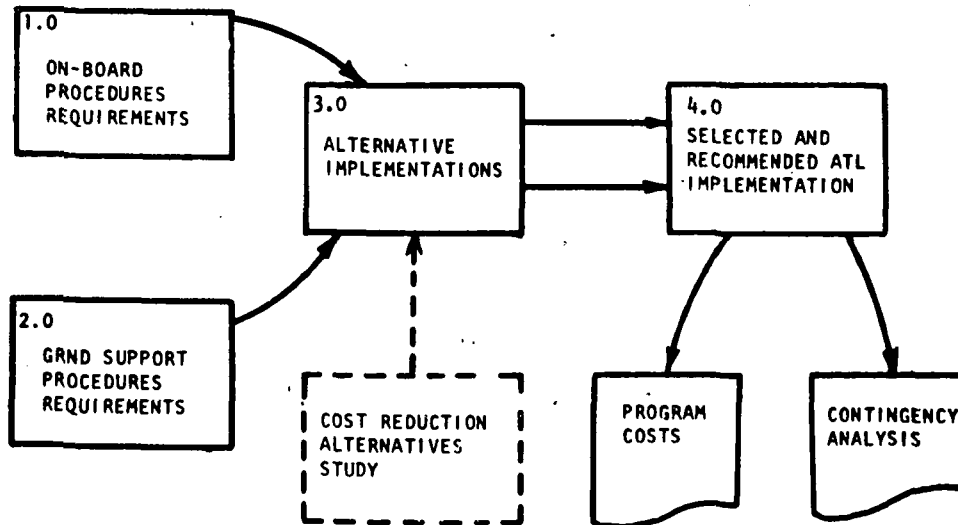

Figure 1.1-1. Study Approach

On-board procedures or operations were identified for 25 candidate ATL experiments in Task 1.0. These operations were segregated into mandatory on-board computerized services and command/control/monitor services that could be accomplished either by manual (hardwired), computer-aided, or automated techniques.

In Task 2.0, the mission analysis/planning and project management tasks pertaining to ground operations were evaluated to establish required/desired computer support.

Alternate implementation concepts for both the on-board services and ground operations were synthesized and evaluated in Task 3.0. One task of a second adjunct study to SUIAS, the *Cost Reduction Alternatives Study (CRAS)*, was conducted in parallel with SRAS and significantly influenced the efforts of Task 3.0. In SRAS, the original intent was to assess the optimum use of the Spacelab CDMS. The CRAS effort broadened the scope of evaluating alternate on-board accommodation of services to include the use of dedicated mini/micro processors for mandatory computerized services of ATL experiments.

Programmatic evaluations were conducted in Task 4.0. Commonality of procedures and reuse of software and software-related hardware were the prime drivers in the development of a recommended ATL implementation approach for flight and ground operations. An assessment of the potential impact of not implementing the recommendations and/or the unavailability of certain NASA agency resources was conducted as part of a contingency analysis.



1.2 SYNOPSIS OF STUDY RESULTS

ON-BOARD OPERATIONS

The results of the CRAS effort indicated that maximum utilization of experiment-dedicated mini/micro processors was the most cost-effective approach to accommodate mandatory computerized on-board services. Mini- and micro-processors that could perform the required services and consisted of commercially available equipment were synthesized. In addition a software development tool, called the flight software support system (FSSS), was conceptually defined to maximize the reuse of software and minimize the mission-unique software requirements.

The CRAS concept for accommodation of mandatory computerized on-board services was adopted in this study. Specific application of the concept to three reference ATL payloads indicated that a typical payload would require 6 mini-processors, 14 micro-processors, and 2500 mission-unique statements of software.

Command, control, and monitor functions of the reference ATL experiments were evaluated to determine the impact of alternate implementation approaches. If these functions were hardwired (dedicated control panels) the average cost per experiment was about \$5K. Accommodation of these functions by a computer-aided approach required actuation hardware, software, and an interactive terminal (CRT/keyboard/micro-processor). The actuation hardware costs were nominal (about \$600 per experiment). Both non-recurring and recurring software was required. The non-recurring software was a delta to the FSSS for preparation of measurements and operating procedures in the interactive terminal/dedicated mini-processor of the experiments and was estimated at \$75K. Recurring software to code the measurements/procedures was estimated at \$6.3K per experiment. Two interactive terminals (\$3K each), which could support two flights per year and would be utilized as common work stations in the Spacelab, were also identified.

Complete automation of command/control functions of typical ATL experiments was discarded. The inclusion of decision algorithms in the software precluded the use of the FSSS software development approach. The estimated cost for the automatic command/control approach for the typical ATL experiment was \$155K.

Although the computer-aided approach was more costly than the hardwired approach, it was recommended for use on ATL experiments that did not require manual dexterity and/or visual acuity. The flexibility and versatility of the computer-aided approach will be more compatible with the anticipated reflight and modifications inherent in an evolving technology program such as Langley's ATL. Also, ATL experiments will be flown in pallet-only as well as habitable-module Spacelab configurations. The available panel space in the Orbiter aft-flight-deck precludes dedicated/individual experiment command/control/monitor panels for the desired complement of experiments in each payload.

GROUND OPERATIONS

An assessment of the mission analysis/planning and documentation tasks associated with ATL ground operations identified 29 essential and 5 highly



desirable computerized services. New development of the attendant software programs would be in excess of \$13M. Coordination with MSFC indicated that an on-going software development program at MSFC would result in computer programs that appear to fulfill Langley's requirements. The MSFC effort includes tutorial software that will enable personnel relatively unskilled in computer programming to utilize the programs. The primary emphasis at this time is to use remote terminals to exercise the computer programs. However, an initial attempt has been made to compile some of the software for use in a mini-processor. In this study, SRAS, the compilation of the MSFC programs tailored to Langley's needs and augmented with a few additional programs was called the ground software support system (GSSS). As the MSFC effort is an on-going activity, the final status/results are not known. For purposes of programmatic costing, a worst case estimate of \$700K was assumed to convert the MSFC program to a GSSS suitable to Langley's requirements.

There are two basic alternate implementation approaches for implementation of the GSSS. One approach, *batch processing*, was eliminated because of the inherent time-delay, inconvenience, and documentation requirements associated with remote exercising of computer programs based upon written requests/data sheets. The second basic approach involves interactive terminals that permit a GSSS user to *communicate* directly with software programs. By the means of a CRT/keyboard a user queries the program which, in turn, in real time, provides results and leads the user step-by-step in the exercising of the program.

Five interactive terminal approaches were evaluated. Two of the approaches utilized a remote terminal approach. The computer or data processing center is either *on site* with the user, or remotely located. The primary shortcoming of these approaches were the host machine-time user costs. The other three interactive terminal approaches utilized dedicated mini-processors. The differences between these approaches are the mechanizations of the memory systems; centralized disc, dedicated tape, or dedicated disc. The mini-processor dedicated disc approach was preferred because of the flexibility and versatility of this mechanization even though it was slightly more costly than the other two dedicated processor approaches. Each mini-disc system will cost \$37K and could support two flights per year.

Other than the disc memory system the mini-disc concept could utilize the same equipments as the on-board mini-processors. Although not specifically addressed in this study, the PI's must individually conduct a significant mission planning/analysis effort. The PI's dedicated on-board mini-processors, combined with a disc memory set and the GSSS, could be used for this effort.

PROGRAMMATICS

As the ATL program is comprised of a broad range of experiments the on-board service requirements vary significantly. Some experiments require primarily manual dexterity and/or visual acuity and are not adaptable to computer-aided command and control. Thus, a representative ATL payload was synthesized in order to derive programmatic costs. This payload consisted of six experiments that incorporated computer-aided command and control and four experiments that had hardwired command and control. Reuse of hardware and software was postulated as follows.



ITEM	REUSE	RATIONALE
INTERACTIVE TERMINALS MINI-PROCESSORS	100%	SHARED; EQUIPMENT COMPLEMENT WILL SUPPORT 2 FLIGHTS/YEAR.
MICRO-PROCESSOR ACTIVATION HARDWARE HARDWIRED PANELS	40%	EQUIPMENT INTEGRAL PART OF EXPERIMENT; REFLIGHT OF EXPERIMENTS ASSUMED TO BE 40%
DEDICATED PROCESSOR SOFTWARE	25%	PROCEDURES WILL PROBABLY CHANGE SIGNIFICANTLY ON EACH REFLIGHT
CDMS SOFTWARE	0%	NEW EXPERIMENT MIX--MISSION TIMELINE EACH FLIGHT

Three ATL traffic models were evaluated; baseline or *Yardley* model, two flights per year maximum, and one flight per year. Application of the appropriate cost factors and reuse criteria indicated that the recurring software and software-related hardware costs averaged slightly more than \$200K per flight. Minor variations between traffic models were due to different utilization/amortization of the software-related hardware items.

The recommended approaches for ATL software implementation are dependent on two elements--the FSSS and the GSSS. An assessment of the impact of not having these two software preparation tools was conducted. If the FSSS is not available the delta recurring software development costs that would accrue from four ATL flights would equal the development costs of the FSSS. If the GSSS is not available the remote-terminal/remote-DPC concept could be utilized to link Langley to MSFC. Implementation of the Langley GSSS is not time-critical as the cost impact is of the order of \$30K per flight after the first flight. It is recommended that implementation of the Langley GSSS be postponed until the MSFC software program development activity is continued for at least another year.

The reference ATL pallet-only payload was specifically evaluated. The available panel space in the Orbiter aft-flight-deck (AFD) will not accommodate dedicated command/control/monitor panels for the reference ATL payload. If the computer-aided command/control approach were adopted for seven of the 12 experiments in the reference payload, the AFD panel space is marginally adequate. Specific panel layouts and consideration of potential equipment interferences may eliminate the margin and dictate either restricting the experiments on pallet-only payloads to those adaptable to the computer-aided approach or integrating the panel requirements of multiple experiments. It is believed that integrated panel costs will greatly exceed the adaptation costs associated with the computer-aided approach.

SUCCINCT SUMMARY

The primary results/conclusions/recommendations of the SRAS are as follows:

1. Maximize the use of dedicated mini/micro-processors. (from CRAS)
2. Develop the FSSS for both mandatory on-board services and command/control functions.



3. If appropriate (manual dexterity/visual acuity not required), implement the computer-aided command/control approach.
4. Develop a GSSS tailored to Langley's application.
5. Implement the GSSS with a dedicated mini-processor/disc system.
6. Emphasize experiments adaptable to the computer-aided command/control approach on pallet-only Spacelab flights.



2.0 SIGNIFICANT STUDY RESULTS

A summary of the major trades and analyses conducted during the study, and the primary conclusions of these efforts are presented in this section.

2.1 ON-BOARD PROCESSING REQUIREMENTS DATA BASE

In order to assess the potential use of computers and software to support the on-board experiment operations, a definitive set of data for each of the 25 representative ATL experiments was developed. These data were derived from TM X-2813, *Study of Shuttle-Compatible Advanced Technology Laboratory* (Langley, September 1973), the *Shuttle Sortie Payload Description Study* (MSFC), and discipline specialists/surrogate PI's on the Rockwell Space Division Staff. The representative ATL experiments and their groupings into three typical ATL payloads are indicated in Table 2.1-1.

Table 2.1-1. ATL Experiment Definition and Payload Groupings

EXPERIMENT IDENTIFICATION	EXPERIMENT SSPDA NO.	PAYLOAD 1 MODULE + PALLET	PAYLOAD 2 MODULE + PALLET	PAYLOAD 3 PALLET-ONLY
<u>NAVIGATION</u>				
NV-1 MICROWAVE INTERFEROMETER	XST-001			X
NV-2 AUTONOMOUS NAVIGATION	XST-004			X
NV-3 MULTIPATH MEASUREMENTS	XST-007	X		
<u>EARTH OBSERVATIONS</u>				
EO-1 LIDAR MEASUREMENTS	XST-010			X
EO-2 TUNABLE LASERS	XST-011	X		
EO-3 MULTISPECTRAL SCANNER	XST-012		X	
EO-4 RADIOMETER	XST-002			X
EO-5 LASER RANGING	XST-003	X		
EO-6 MICROWAVE ALTIMETRY	XST-005		X	
EO-7 SEARCH AND RESCUE AIDS	XST-006			X
EO-8 IMAGING RADAR	XST-008			X
EO-9 RF NOISE	XST-009	X		
<u>PHYSICS AND CHEMISTRY</u>				
PH-2 BARIUM CLOUD RELEASE	XST-015	X		X
PH-3 AEROSOL PROPERTIES	XST-016	X	X	
PH-4 MOLECULAR BEAM LAB	XST-017	X		X
PH-6 METEOR SPECTROSCOPY	XST-019			X
<u>MICROBIOLOGY</u>				
MB-1 COLONY GROWTH	XST-020	X	X	
MB-2 MICRO-ORGANISM TRANSFER	XST-021		X	
MB-3 BIOCELL ELECT FIELD OPACITY	XST-022	X		
MB-4 BIOCELL ELECT CHARACTERISTICS	XST-023		X	
MB-5 BIOCELL PROPERTIES	XST-024		X	
<u>ENVIRONMENTAL EFFECTS</u>				
EN-1 MICRO-ORGANISM SAMPLING	XST-027	X	X	X
EN-3 NON-METALLIC MATERIALS DEGRAD	XST-029		X	X
<u>COMPONENTS AND SYSTEMS</u>				
CS-2 ZERO-G STEAM GENERATOR	XST-026		X	
CS-X CONTAMINATION MONITOR	XST-040	X	X	X

Data packs were prepared for each of the ATL experiments and submitted to Langley in September 1975. The following documents were included in the experiment data packs: (1) a narrative description identifying the experiment's purpose, sensors, and implementation approach; (2) an equipment list of the experiment assemblies and their potential Spacelab location; (3) condensed equipment performance and operations descriptors; (4) command and data signal flow paths; (5) a measurement list including form, rate, source, and destination requirements; (6) control requirements; and (7) an experiment data management requirements matrix that reflected the entire flight regime.

2.2 ON-BOARD COMPUTER SERVICES

The initial scope of this effort was significantly expanded as a result of a parallel adjunct SUIAS effort, the *Cost Reduction Alternatives Study (CRAS)*. Part of the CRAS effort was to evaluate the use of dedicated mini/micro-processors as well as the Spacelab CDMS for on-board experiment computer services. (Originally the SRAS effort was limited to establishing the preferred CDMS utilization.) The result of the CRAS effort was to recommend the maximum utilization of dedicated processors. As this result directly influenced the SRAS effort, the CRAS results are summarized herein and then applied to the representative ATL payloads.

In CRAS, five representative Spacelab design reference missions were analyzed by creating experiment definition data packages similar to but not to the depth of the data packs discussed in Section 2.1. Each experiment of each payload was analyzed to determine required/mandatory on-board computer services. Figure 2.2-1 summarizes this analysis. Twenty-seven services were identified. Not only were

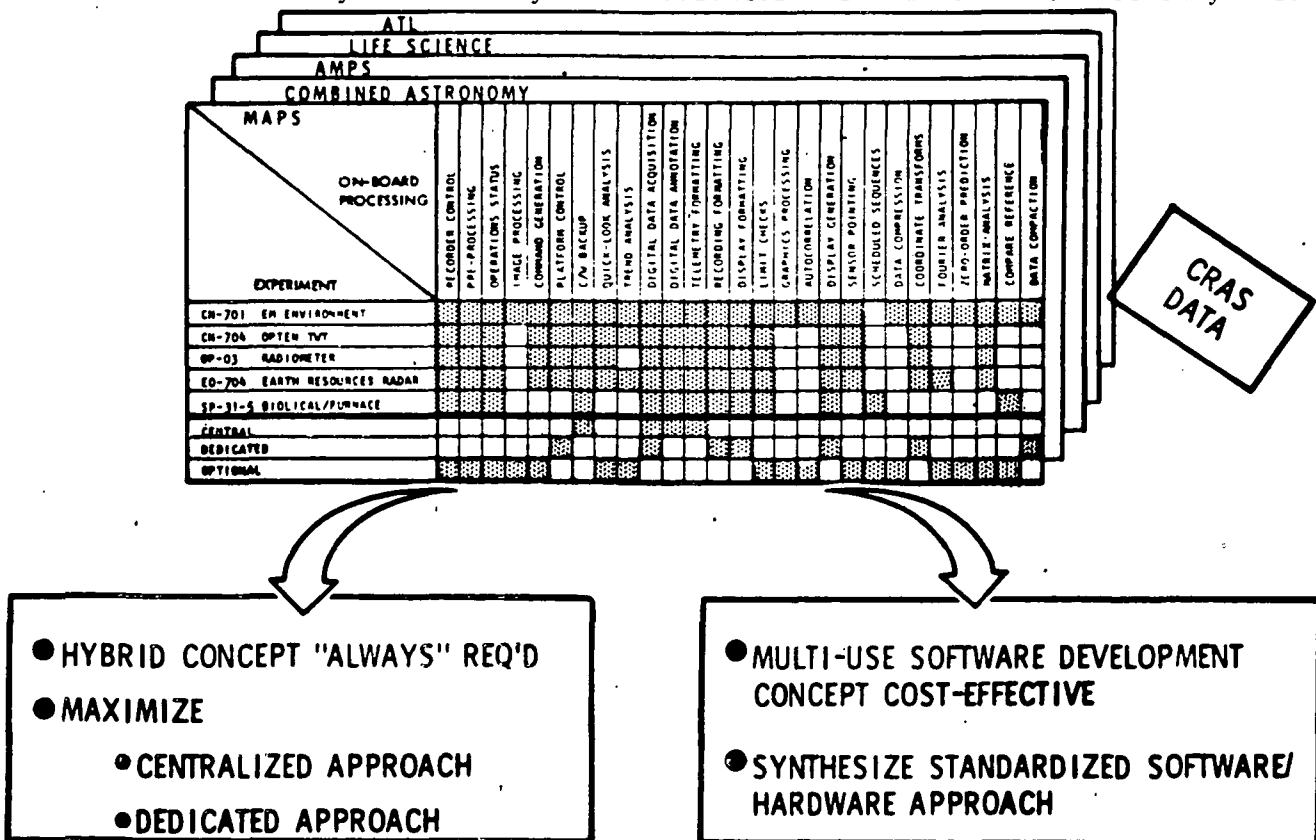

Figure 2.2-1. On-Board Processor Flight Hardware Definition



these services required by several experiments within a payload, but multiple payloads required the same services. In addition, an evaluation of these services coupled with an assessment of the Spacelab CDMS and the Spacelab/Orbiter interfaces indicated that some services must be implemented in dedicated processors, some in the CDMS, and others could be implemented in either the CDMS or dedicated processors. That is, a hybrid on-board computer mechanization approach was *always* required. In order to establish a preferred approach, software development and implementation concepts were synthesized for a *maximized* central (CDMS) approach and a *maximized* dedicated processor approach.

Because of the repetitive nature of the on-board services the first step in the synthesis process was to define a software development technique that would maximize the reuse of software. The technique was called the flight software support system (FSSS) and is illustrated in Figure 2.2-2. The 27 identified on-board services comprise the library of the FSSS. After initial development, only new initialization data (data tables) are required for subsequent application. The remaining elements of the FSSS (tutorial, source code editor, compiler/assembler, etc.) are also software. These elements are also a one-time development and provide the capability to link library routines to a mission-unique flight applications program. Admittedly, some of these elements are machine (computer) unique. However, an industry trend is to develop software and hardware that is vendor-interchangeable. Only a minor level of standardization will be required.

Even with the conceptually defined FSSS, mission-unique software is required. Estimates of this software for each of the five CRAS payloads were established to provide the basis for software preparation costs.

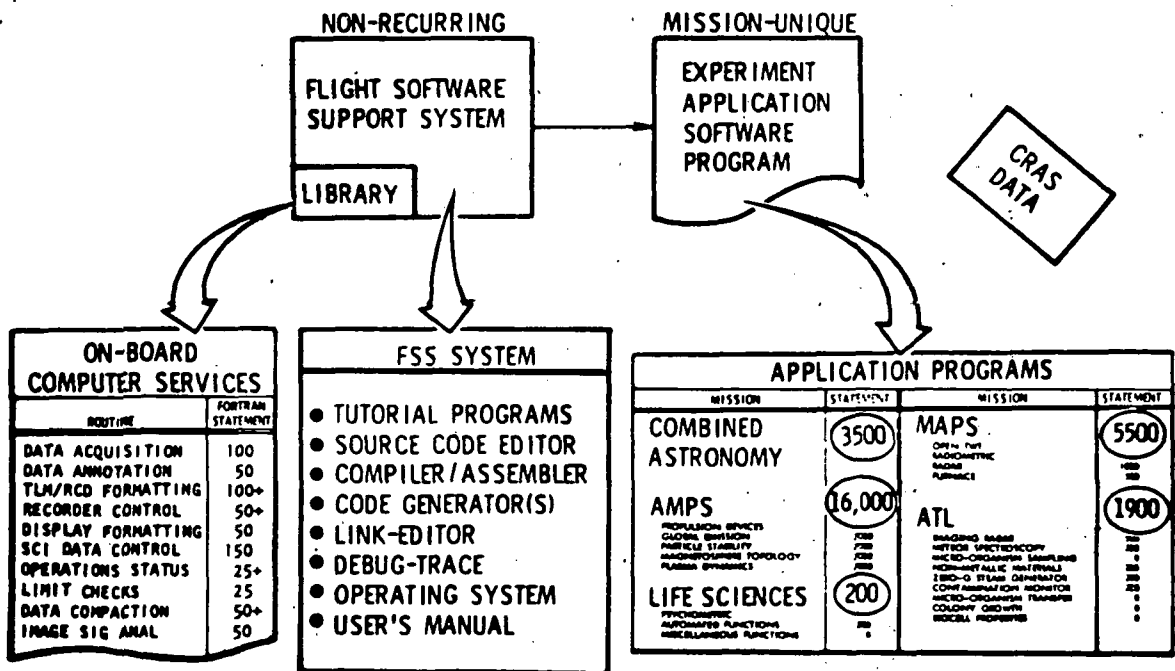

Figure 2.2-2. Software Development Approach



The preparation of the mission-unique software for the two approaches is illustrated in Figure 2.2-3. In the mini/micro approach each experimenter, with minimal programmer support, develops his own flight applications software for experiment operations. *Measurements* data must be integrated at a central activity because of the constrained Spacelab/Orbiter interface. The products of this approach are a series of application programs (shown as tapes) for each experimenter's mini- and micro-processors plus one program for the CDMS.

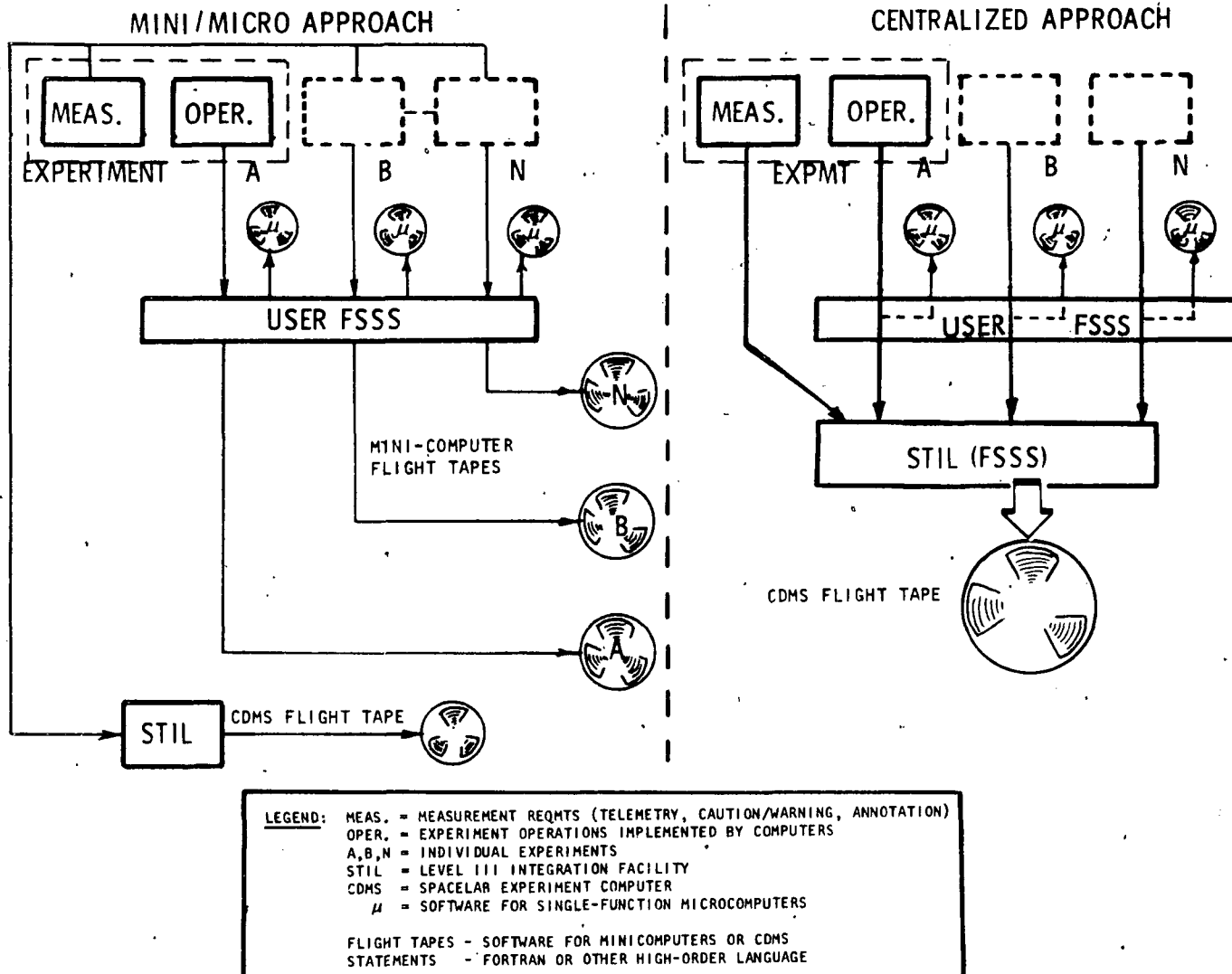

Figure 2.2-3. Experiment Flight Software Development

In the centralized approach only micro-processor software is developed with the user FSSS by the experimenter. All other experiment operations must be rigidly specified and controlled as the flight applications software will be developed at a centralized software test and integration laboratory (STIL) for incorporation into the CDMS. The significance of the documentation/control of the operations is reflected in the cost estimates for software preparation. Based upon previous/similar software development activities at Rockwell the per-statement software preparation cost is \$62. The ASSESS program at Ames Research Center is more characteristic of the mini/micro approach. Estimates of



the software development costs of the ASSESS program plus record-type documentation (which is adequate for the experimenters) and contractor overhead indicated per-statement costs of about \$31.

An additional major consideration in the evaluation of the two implementation approaches was the hardware required. The CDMS is furnished with the Spacelab and thus no unique costs for on-board equipment were applicable. However, the software prepared in the centralized approach is remote from the experiment hardware. Thus, experiment simulation (hardware or software) is required to validate the flight software at the software development site, and CDMS interface simulation hardware is required to verify the compatibility of the experiment system with the Spacelab CDMS at the PI's site. Postponing the validation of the software/hardware interface until Level III integration was considered to be unacceptable.

Introduction of the mini/micro approach requires additional flight and ground hardware. Processor models consisting of commercially available equipment were synthesized (Figure 2.2-4). Appropriate peripherals were included so that the preparation of the flight software could be accomplished with the flight processors. As the PI is directly involved in the development of the software and uses the flight processor, neither simulation software nor hardware is required. The validation process with the mini/micro approach is illustrated in Figure 2.2-5.

Cost factors were derived for each element of both on-board mechanization approaches and applied to each of the CRAS representative payloads. Programmatic costs were developed for each approach as illustrated in Figure 2.2-6. Equivalencies between the CRAS representative payloads and the other payloads in the traffic model were established. Schedules of each mission type for the three different traffic models were developed. Learning curves/software reuse estimates were defined and costs by mission type were generated. Summations of the programmatic costs indicated that the mini/micro approach would be about 60 percent of the costs of the centralized approach. Also, a gross evaluation of the impact of not having the FSSS indicated recurring costs would increase by about a factor of 4.

The *maximized* mini/micro-processor approach was incorporated in this study. Each of the reference ATL experiments/payloads were analyzed to establish the complement of mini- and micro-processors and flight application program statements required for the on-board services as illustrated in Figure 2.2-7. The requirements of the three reference ATL payloads are summarized in Table 2.2-1. In order to subsequently develop ATL programmatic costs a nominal ATL payload requiring 6 mini-processors, 14 micro-processors, and 2500 mission-unique flight application program statements was identified. The CDMS *software* integration activity required for each ATL payload is summarized in Figure 2.2-8. New computer software is not required for each mission. The CDMS programs for Spacelab subsystem *measurement* functions can be utilized with the experiment-unique initialization data.

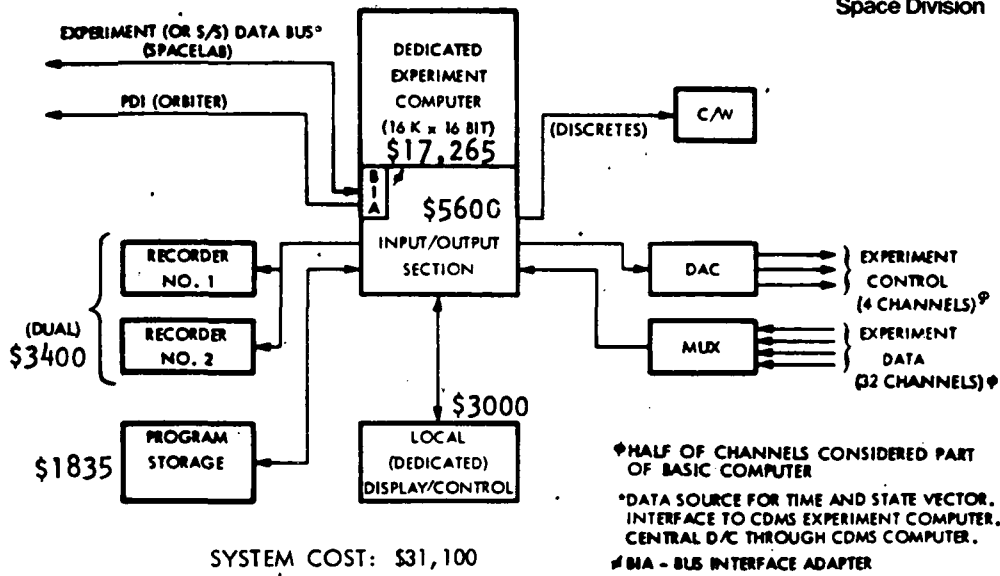

MINI-COMPUTER FLIGHT SET

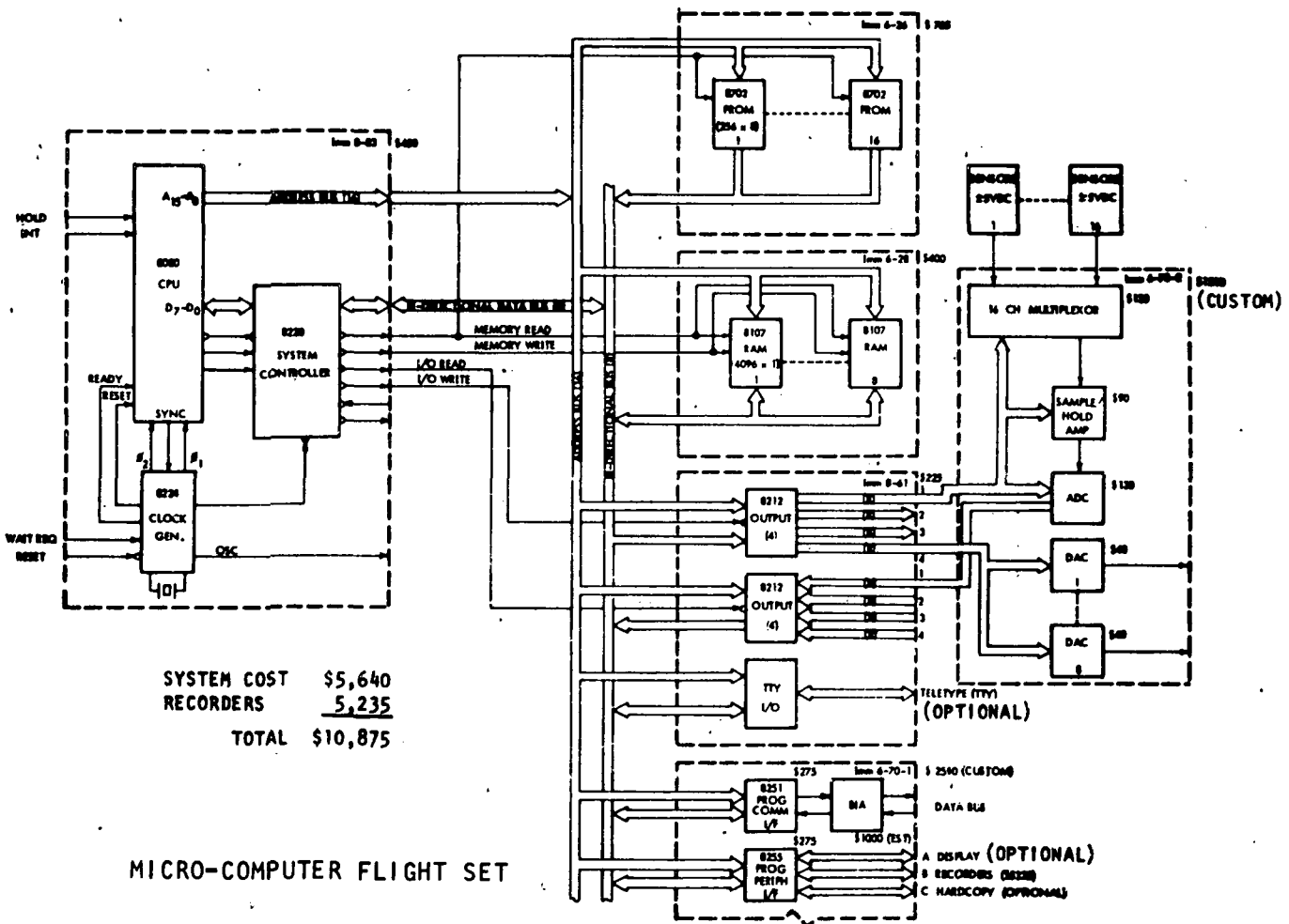

Figure 2.2-4. On-Board Processor Flight Hardware

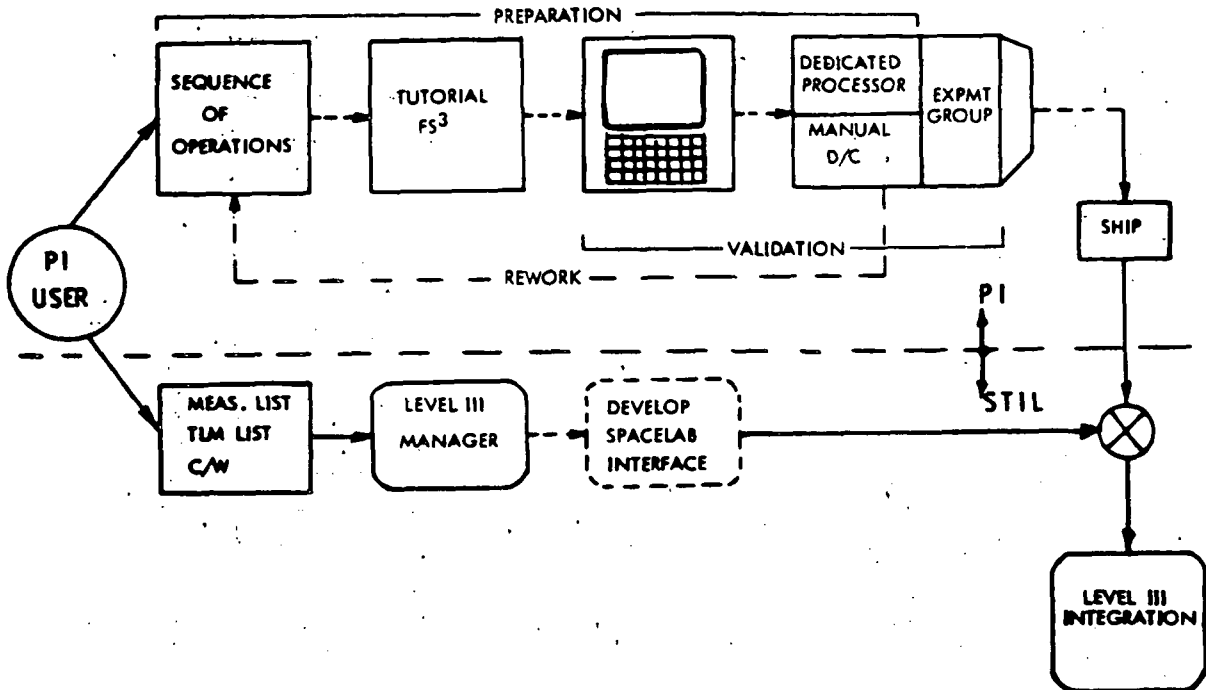

Figure 2.2-5. Mini/Micro Processor Software Preparation/Validation

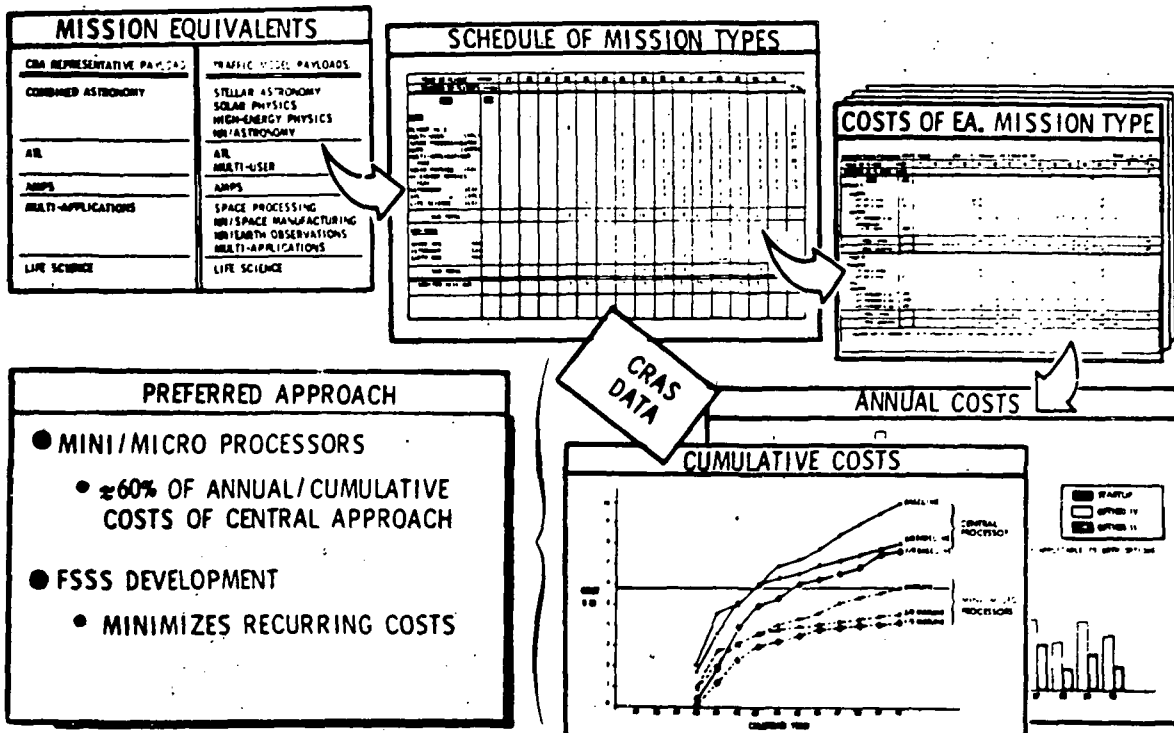

Figure 2.2-6. Programmatic Cost Evaluation

ATL PAYLOAD NO. 3

EXPERIMENT

ON-BOARD COMPUTER SERVICES

	RECORDER CONTROL	PRE-PROCESSING	OPERATIONS STATUS	IMAGE PROCESSING	COMMAND GENERATION	PLATFORM CONTROL	C/W BACKUP	QUICK-LOOK ANALYSIS	TREND ANALYSIS	SCIENCE DATA CONTROL		DIGITAL DATA ACQUIS.	DIGITAL DATA ANNOTA.	TELEMETRY FORMATTING	RECORDING FORMATTING	DISPLAY FORMATTING	LIMIT CHECKS	GRAPHICS PROCESSING	AUTOCORRELATION	DISPLAY GENERATION	SENSOR POINTING	SCHEDULED SEQUENCE	DATA COMPRESSION	COORD. TRANSFORMS	FOURIER ANALYSIS	ZERO-ORDER PREDICTION	MATRIX ANALYSIS	DATA COMPACTION	COMPLEMENT		STATEMENTS	
	1	2	3	4	5	6	7	8	9	10	11	12	13	14	15	16	17	18	19	20	21	22	23	24	25	26	27	28	MINI-PROCESSORS	MICRO-PROCESSORS		
NV-1 MICROWAVE INTERFEROMETER			M				C			M		C	C	C		M				M			μ						μ	1	2	300
NV-2 AUTONOMOUS NAVIGATION			M				C					C	C	C		M				M				μ						1	1	250
EO-1 LIDAR MEASUREMENTS			M						M			C	C	C		M				M										1		200
EO-4 RADIOMETER	M				M							C	C	C		M				M	μ	M								1	1	1050
EO-7 SEARCH/RESCUE AIDS			M				C		M			C	C	C		M				M								μ	1	1	250	
EO-8 IMAGING RADAR			M				C		M			C	C	C		M				M								μ	1	1	250	
PH-2 BARIUM CLOUD RELEASE												C	C	C	μ	μ															2	100
PH-4 NEUTRAL GAS PARAMETERS												C	C	C		M		μ		M	μ	M								1	2	300
PH-6 METEOR SPECTROSCOPY				μ								C	C	C		μ				μ											3	150
EN-1 MICRO-ORGANISM SAMPLING																																
EN-3 NON-METALLIC MATERIALS				μ			C					C	C	C							μ										2	100
CS-X CONTAMINATION MONITOR												C	C	C																		
																TOTAL											8	15	2950			

LEGEND
 M ■ MINI-PROCESSOR
 μ ■ MICRO-PROCESSOR
 C ■ CDMS PROCESSOR

Figure 2.2-7. ATL Payload 3 On-Board Processing Requirements

2-8
 SD 76-SA-0028-1

Table 2.2-1. ATL On-Board Processing Requirements

	MINI PROCESSORS	MICRO PROCESSORS	SOFTWARE STATEMENTS
ATL PAYLOAD 1	5	14	3300
ATL PAYLOAD 2	2	12	1000
ATL PAYLOAD 3	7	15	2950
NOMINAL ATL PAYLOAD	6	14	2500
COST FACTORS (CRAS DATA)	\$33K EACH	\$11K EACH	\$31 PER STATEMENT

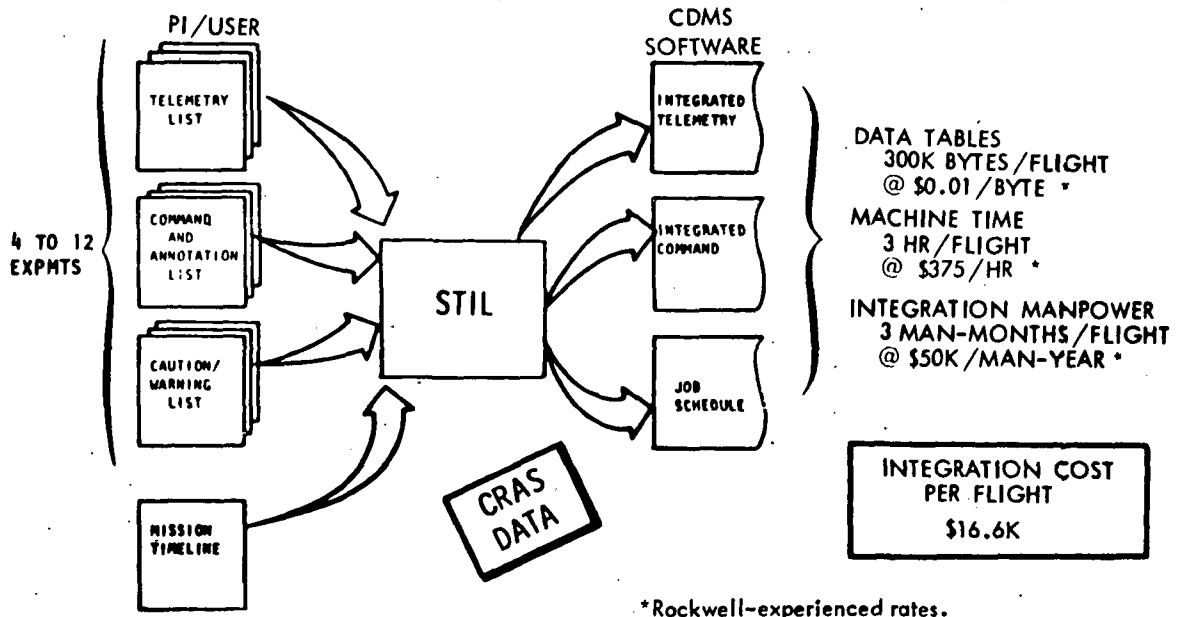

Figure 2.2-8. STIL Function with Mini/Micro Processor Approach



2.3 ON-BOARD COMMAND AND CONTROL

In addition to the mandatory computerized on-board services, alternate approaches to perform the nominally manual command/control functions of experiment operations were evaluated. A basic *manual* (hardwired) approach was synthesized for each experiment. *Computer-aided* and *automated* mechanizations for these same hardwired functions were also considered. The three approaches are illustrated in Figure 2.3-1. The hardwired approach reflects a typical laboratory configuration with discrete switches, potentiometers, indicators, lights, and

AUTOMATIC / COMPUTER-AIDED CONTROL

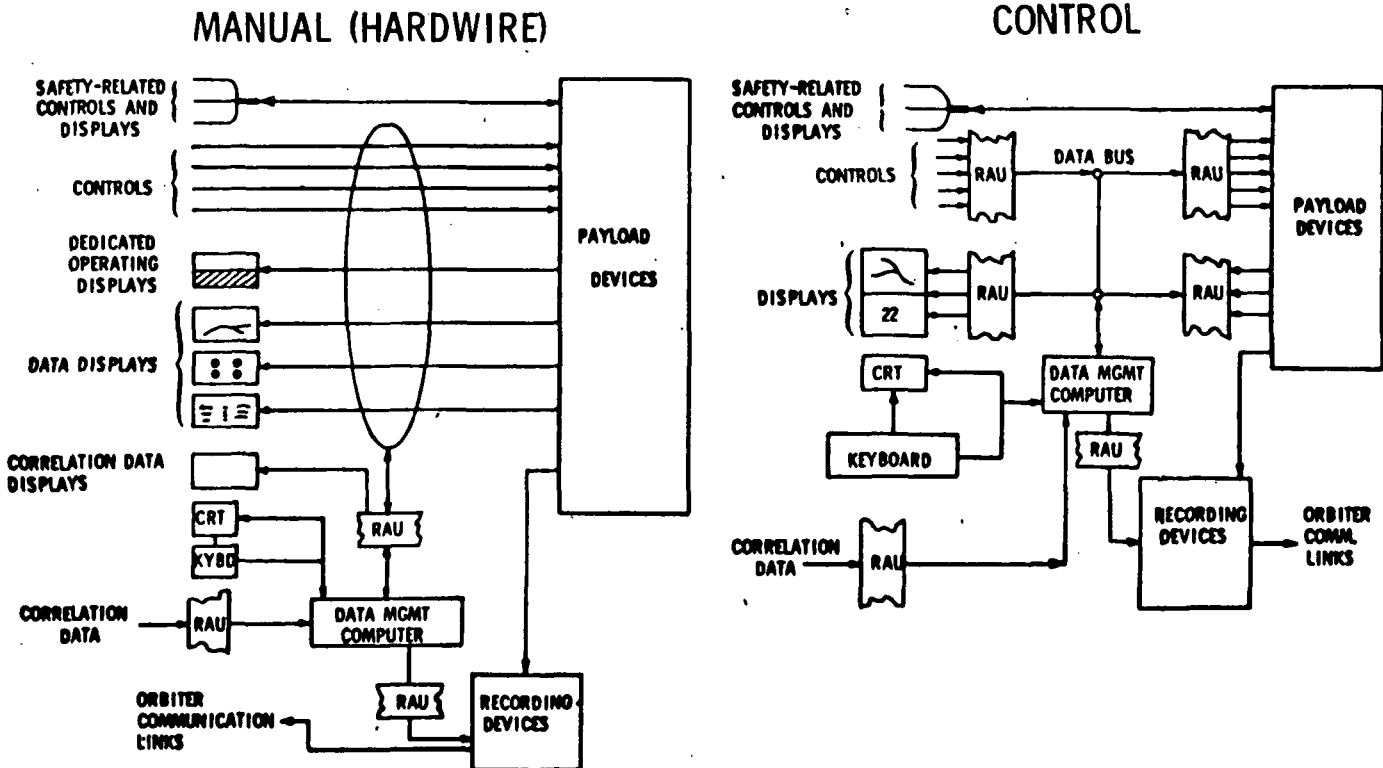

Figure 2.3-1. Data Management Design Concept Comparison

meters. In the computer-aided approach the majority of the discrete components are replaced by an intelligent terminal (CRT/keyboard). Some functions must be hardwired for safety reasons (e.g., pyros, emergency backups, etc.). Instead of direct wiring from discrete components to remotely located experiment equipment, command/control/monitor is accomplished via an experiment command bus (independent of the Spacelab experiment data bus) with the computer-aided approach. Actions are initiated via the keyboard; reactions/status are monitored on the CRT. The hardware configuration with the automatic approach is the same as the computer-aided approach; the difference is in the software. Decision-algorithms and sequencing are done with software. The operator monitors the activities and (if necessary) overrides the automated commands/sequences. For each command/control implementation approach, the pertinent hardware and software cost elements were defined and estimated.



HARDWIRED APPROACH

In the case of the hardwired approach the design, development, and integration of the control panel and the cost of the components were considered. Based upon the definition data in the experiment data packs the discrete panel components for each experiment were identified (Figure 2.3-2). Note that only discrete

Experiment	Toggle Switches		Talkbacks		Rotary Switches		Digit Indicators		No. of Lights		Miscellaneous	
	ON/OFF	Positions		Positions		No. of Switches	No. of Positions	No. of Indicators	No. of Digits	Bit		Discrete
		2	3	1	2							
1. NV-1	7*	2		7	2	1	5	1	3	9		
2. NV-2	9* (1**)			11		3	2 (5-pos.)	11 1	2 6	11		
3. NV-3	10* (4**)			6				1 2	3 3		Sig. strength meter; receiver tuner (2 knobs)	
4. EO-1	6 (1**)			5		1	3 (5-pos.)	9	2	9	One analog potentiometer	
5. EO-2	13 (3**)			10	1	1	3	3 2	2 2	9	Sig. strength meter; two potentiometers (align, adjust receiver)	
6. EO-3	8 (4**)	3		4	3	5 1 4	7 5 9/2 gang	9	3	7		
7. EO-4	4	5		9		2 1 1 1	7 & 4 2 3 5	3 2	3 5	1	5 pots	
8. EO-5	8 (4**)			7		2	5 4	6	3	10		
9. EO-6												

Figure 2.3-2. ATL Experiment Panel Components

components are indicated; stand-alone displays such as oscilloscopes, TV monitors and spectrum analyzers will require additional panel space and are applicable regardless of the implementation approach. Based on empirically derived formulas (previous Rockwell programs), panel area and weight requirements were developed. Cost estimating ratios for aerospace-qualified (\$1800/lb) and Mil-STD programs (\$170/lb) were applied. These data are reflected in Figure 2.3-3. As Spacelab

PAYLOAD	EXPERIMENT	WEIGHT (LB)	COSTS (1976 \$K)	
			AEROSPACE	MIL-STD
1	NV-3	30.7	55.3	5.2
	EO-2	40.6	73.0	6.8
	EO-5	43.5	78.3	7.3
	EO-9	26.0	46.8	4.4
	PH-2	71.8	129.2	12.1
	PH-3	23.4	42.1	3.9
	PH-4	24.9	44.8	4.2
	EN-1	16.1	29.0	2.7
	CS-X	21.9	39.4	3.7
	MB-1/3	*	*	*
	TOTAL		537.9	50.3
2	EO-3	54.9	98.8	9.2
	EO-6	44.9	80.8	7.5
	PH-3	23.4	42.1	3.9
	MB-5			

Figure 2.3-3. Comparison of Aerospace and Mil-STD Costs

payload controls are not crew safety provisions (They must be operationally safe but do not provide crew survival/safe return capability.), the use of Mil-STD design criteria was considered applicable. The average cost of the design, components, development, test, and documentation for the ATL experiments was about \$5K each.

COMPUTER-AIDED APPROACH

In order to implement the computer-aided approach for experiment command/control/monitor functions, additional hardware is required at both ends of the transmission link. Figure 2.3-4 illustrates a typical computer-aided

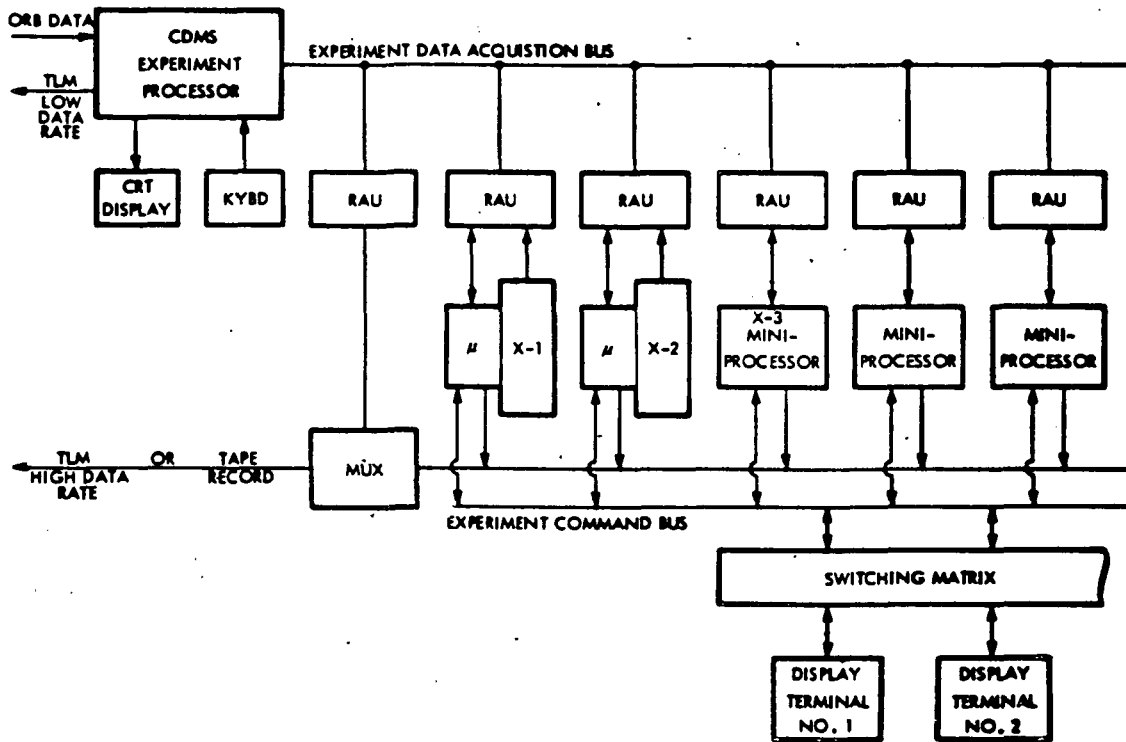

Figure 2.3-4. Level III/II Integration Configuration (Typical)

implementation for an ATL Spacelab payload. The experiment operator is provided intelligent display terminals (CRT/keyboard/micro-processor) to command/control/monitor experiment actions/reactions via the experiment command bus to dedicated mini/micro-processors in each ATL experiment system. Overall control of experiment operations and the flow of data to/from the Orbiter is maintained by the Spacelab CDMS via the experiment data acquisition bus-RAU link to the experiments and the CDMS MUX.

The interface hardware at the experiment end of the transmission link is illustrated in Figure 2.3-5. Actuators and decoder elements are required to recognize, interpret, and effect the translation of a digital signal to the desired control action. The average cost of this activation hardware is about \$600 per experiment. The mini/micro-processors can be the same hardware described previously for the mandatory on-board computerized services. The intelligent

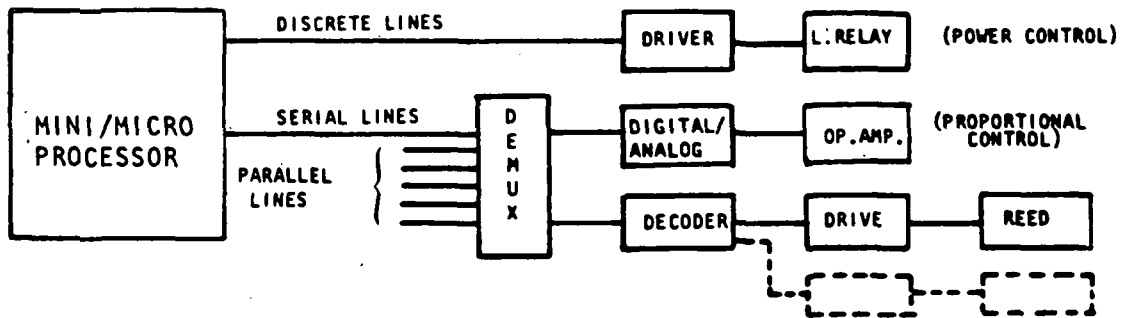

Figure 2.3-5. Computer-Aided Hardware Cost Factors
(Example: Microwave Radiometer - EO-4)

terminal used during development of the experiment system can also be the same unit used for on-board services software development. However, two intelligent terminals for flight use were allocated to Langley (\$3K each).

Three alternatives were evaluated for the software associated with the computer-aided command/control approach. The first alternative used the intelligent terminal as a command generation and measurement monitor mechanism. The command generation consisted of replacing the manual switch/potentiometer operation with a digitally encoded signal in response to keyboard inputs. Required operations would be listed in an experiment operations handbook. Software for the mini/micro-processor would be required to decode the command signal (keyboard), energize the actuators, and acquire/process the measurement data for display on the intelligent terminal. A typical measurement display page is shown in Figure 2.3-6. Each measurement display page is customized to a particular experiment by adding the experiment-unique data tables. The basic software can be developed by using the FSSS, provided certain action-analysis routines are added. The delta non-recurring cost to the FSSS is estimated to be \$62K (1000 statements @ \$62 each). The mission-unique data tables were estimated to average about 800 characters per experiment which at \$0.01/character is only \$8 per experiment per mission.

MICROWAVE INTERFEROMETER						D	H	M	S
						12	20	13	05
NO.	NAME	VALUE	UPPER	LOWER	UNITS				
1	PALLET POWER	115	120	110	VAC				
2	CHANNEL A	-135	-100	-160	dBm				
3	CHANNEL B	-122	-100	-160	dBm				
4	CHANNEL C	-150	-100	-160	dBm				
	⋮	⋮	⋮	⋮	⋮				
17	TAPE REMAINING	1200	-	-	FEET				
18	TRANS. OUTPUT	20	100	10	mW				

Figure 2.3-6. Typical Measurement Display

The second computer-aided software approach evaluated included a display of operator's procedures on the CRT and automatically displayed the resulting status



--an automated checkoff list. Figure 2.3-7 illustrates the procedures display on the CRT. This capability would require another FSSS delta, estimated to be 200 statements (\$12.4K). The function of this delta would be to analyze the control action requested and set up the communication from one intelligent terminal to one of the several mini- or micro-processors in the ATL payload. In

MICROWAVE INTERFEROMETER		JUNE 30 14:13:06Z		
VERIFY OPERABILITY		MCMILLON		
PROCEDURE	✓*	TIME	FI	
1 RECEIVE ATP X.5	✓	23:13:06M	A13	
2 TV CHAN 1 <u>ON</u>	*			
3 BOOM CAMERA <u>ON</u>	*			
4 TEST LIGHT <u>ON</u>	*			
5 ADJUST FOCUS	✓			
6 VERIFY LIGHT VISIBLE	✓			
7 TEST LIGHT <u>OFF</u>				
8 BOOM CAMERA <u>OFF</u>				
9 ELECTRONICS <u>ON</u>				
10 BIT <u>OFF</u>			A14	
1 TRANSMITTER <u>ON</u>				
2 RECEIVER CHAN SELECT				
3 SIGNAL ON ALL CHANNELS			A15	
4 TRANSMITTER <u>OFF</u>				
5 REQUEST ATP X.6				
(COMPUTER MESSAGE)				
(REMARKS)				

✓ = OPERATOR ENTRY * = CDMS ENTRY Z = GMT M = MET

Figure 2.3-7. Computer Display (Aided)

addition to the data tables required for each experiment for each mission (700 alphanumeric characters for each of 16 orbital operation verification phases at \$0.01/character--\$112), there is also some mission-unique computer software that must be developed. In the conventional remote terminal configuration, multiple intelligent terminals communicate with a central processor that includes the software to identify each terminal. In the proposed Spacelab configuration this situation is reversed--one remote terminal must communicate with several processors. Additional software is required in each dedicated processor to recognize its *call sign* and respond (integration software, commonly called *handshaking*). It was estimated that this function would require 200 statements for each experiment for each mission and cost \$6.2K (200 statements at \$31 each).

The third alternative evaluated was to utilize the Spacelab CDMS intelligent terminal for the computer-aided functions. Even if the simulation hardware and software required for Level IV validation is neglected, the costs would be about \$25K per experiment per mission. Because the software is being developed

remotely and will be integrated into a single machine, the development costs will be \$12.4 for the program (200 statements @ \$62 each), \$12.5K for the integration (3 man-months of effort at \$50K/year), and \$750 of host machine time (2 hours @ \$375/hr).

The second alternative, which included the procedures display, was the recommended approach. The versatility, flexibility, potential reduction in operator mistakes, and capability for automatic recording of all in-flight operations appeared to warrant the additional \$6.3K per experiment (as compared to the alternative that only mechanized the control actions).

AUTOMATED COMMAND/CONTROL

All of the hardware and software of the computer-aided approach is required as part of the automated approach. In addition a software program to make the *decision* to proceed to the next step is required with the automated approach. In order to develop the decision algorithm software, a logic flow diagram such as that shown in Figure 2.3-8 must be developed for each experiment operation. The FSSS cannot be used to create this logic nor the software required to represent the logic. There is no known *tutorial* method to do this task. Based upon Rockwell experience in developing automatic spacecraft subsystems that include decision logic, it is estimated that about 5000 FORTRAN-type statements would be required to automate a typical navigation or earth observation experiment of the ATL. Even at \$31 per statement the per-mission costs would be \$155K per experiment.

EXP. NV-1. MICROWAVE
INTERFEROMETER
BLOCK X.5 VERIFY OPERABILITY

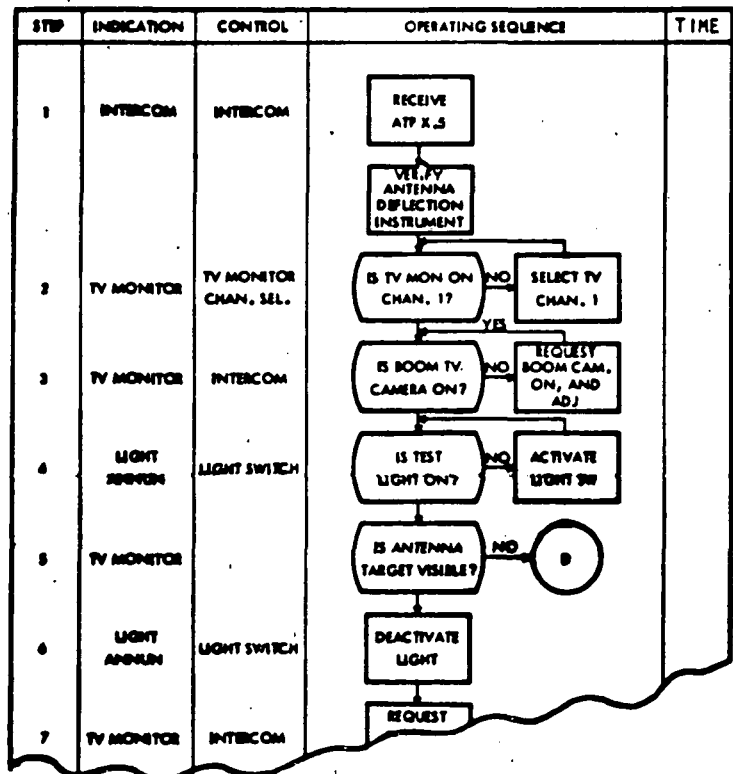

Figure 2.3-8. Automated Control Logic



COMMAND/CONTROL IMPLEMENTATION COMPARISON

A comparison of the recurring costs associated with the three command/control implementation approaches is presented in Figure 2.3-9. The software costs associated with the automated approach preclude this alternative unless critical performance or safety is an overriding factor (e.g., emergency shutdown of a high-powered laser). Comparison of the average hardwired and computer-aided approaches indicates about a \$2K difference per experiment. However, in light of the increased flexibility, versatility, simplification of crew training, simplicity of in-flight operations, adaptability to design change, and compatibility with the pallet-only Spacelab configuration (reduced panel space), the computer-aided approach is preferred where applicable. This recommendation is based upon the assumption that a tutorial system such as the FSSS is developed by the agency and would not be uniquely assessed to the ATL.

	HARDWIRED	COMPUTER-AIDED	AUTOMATED
COST FACTORS	PANEL COSTS \$5.0K	HARDWARE COSTS \$0.6K SOFTWARE COSTS \$6.3K	HARDWARE COSTS \$0.6K SOFTWARE COSTS \$155K
NON COST FACTORS	<ul style="list-style-type: none"> INDIVIDUALIZED PANEL FAMILIARIZATION MANUAL CREW CHECKLIST/RECORDING IN-LINE MODIFICATIONS MAY REQUIRE NEW PANEL CONSTRAINED IN PALLET-ONLY MODE 	<ul style="list-style-type: none"> COMMON CONTROL STATION AUTOMATED CHECKLIST/RECORDING IN-LINE MODIFICATIONS MAY BE ACCOMMODATED IN DATA TABLES COMPATIBLE WITH PALLET-ONLY MODE 	<ul style="list-style-type: none"> SAME SAME IN-LINE MODIFICATIONS COULD REQUIRE EXTENSIVE SOFTWARE CHANGES SAME



VIALE ALTERNATIVES

NOT RECOMMENDED

Figure 2.3-9. Command/Control Concept Comparison (Per Experiment)

It is recognized that the computer-aided approach is not applicable for all ATL experiments. Some ATL experiments require minimal control such as turn-on/turn-off action, or operator physical dexterity/visual acuity such as the microbiology experiments. Therefore, both the hardwired and computer-aided command/control approaches are viable alternatives. The approach selected for each experiment should be based upon that experiment's specific control requirements. In general, if manual dexterity and/or visual acuity is not required, the computer-aided approach is preferred.



2.4 GROUND PROCESSING REQUIREMENTS DATA BASE

The ground processing activities that were assessed included the analyses, planning, engineering, test operations, and management of the support needed for an ATL flight. The two sources for the identification of the required activities were the task WBS and the documentation lists developed in the basic SUIAS. Each WBS entry and document was evaluated to determine the potential computational assistance required. A requirement was identified if the calculations were complex, the volume of data was large, and/or the process was iterative/repetitive.

The assessment indicated that 29 computer-supported processes were essential for efficient ATL ground operations (see Table 2.4-1). In addition, five of the 35 types of documents were also identified as requiring computer support (see Figure 2.4-1). The 29 essential processes were evaluated by the Rockwell programmer staff to establish what application and library routines would be required, and the size of these routines. The results of this analysis are summarized in Figure 2.4-2. The composite total of 218,000 FORTRAN statements at \$62 per statement precluded consideration of a new or Langley-unique development (\$13.5M).

A descriptive data sheet was prepared for each of the 29 essential processes and sent to JSC and MSFC for evaluation. Although programs of a similar nature have been developed at these centers (as well as at other NASA centers and aerospace contractors), MSFC programs indicated a high degree of correlation with the required programs for ATL payload ground processing requirements (see Figure 2.4-3). A continuing program at MSFC is being conducted to develop this type of software. Perhaps most importantly the MSFC programs include the development of tutorial software for each process. In addition, the programs are operational on their S/1108, are being recompiled for an S/360, and some are even being converted for use on a mini-processor (a PDP 11/45).

Table 2.4-1. Essential Computer-Supported Activities

- | | |
|--------------------------------|--|
| • EXPERIMENT GROUPINGS | • INSTRUMENT POINTING |
| • SYST/PROGRAM COST ANALYSIS | • MISSION TIMELINE GENERATION |
| • GROUND TRACE GENERATOR | • EXPERIMENT DATA PROCESSING |
| • TARGET OPPORTUNITY GENERATOR | • ORBIT EPHEMERIS/TIMELINE UPDATE |
| • COMMUNICATIONS COVERAGE | • CONTINGENCY OPERATIONS PLANNING |
| • SOLAR/MISSION GEOMETRY | • SUBSYSTEMS PERFORMANCE MONITOR |
| • RADIATION ENVIRONMENT | • GROUND TRUTH COORDINATION/CONTROL |
| • ORBIT CONTAMINATION | • PAYLOAD (EXPERIMENTS) STATUS MONITOR |
| • ATMOSPHERE MODEL | • THERMAL ANALYSIS |
| • ORBIT DECAY | • MASS PROPERTIES ANALYSIS |
| • ORBIT MANEUVERS | • LOADS/STRESS ANALYSIS |
| • ORBIT ERROR ANALYSIS | • ELECTRICAL POWER ANALYSIS |
| • SUBSATELLITE MOTION ANALYSIS | • DATA MANAGEMENT ANALYSIS |
| • MISSION CONSUMABLES | • STABILIZATION CONTROL ANALYSIS |
| • ORBITER ATTITUDE MANAGEMENT | |



Only two essential programs (stabilization and control analysis, and system/program cost analysis) were not included in the MSFC list. Langley (Flight Dynamics and Control Division) has initiated the development of a stabilization and control analysis program with tutorial software. Rockwell developed a system/program cost analysis model as part of the Radiometer and basic SUIAS effort. Conversion of the operations manual to tutorial software would be a relatively minor task. Specific correlation between the MSFC programs and those programs recommended for documentation tasks was not achieved. However, MSFC's Integrated Mission Program (Figure 2.4-3) should suffice for the mission plan document; the payload activity scheduling program (or Langley's MASS program) can be used for resource scheduling documentation; and commercially available programs can be used for the remainder of the documentation tasks.

Adaptation of the MSFC and commercial programs to run at Langley involves converting, translating, or recompiling the source program (a FORTRAN listing) to fit whatever machine Langley would use. In the optimum case, the cost would be for only the machine time to compile the program. In the worst case, an S/360 to S/unknown translator would be required, which is estimated to cost \$700K.

DOCUMENT TITLE	FLIGHTS/YEAR					RATIONALE
	2	3	4	5		
1. MASTER PROGRAM PLAN AND SCHEDULE	M	M	I	I	PERT MODEL	
2. CONFIGURATION MANAGEMENT REPORT (MONTHLY)	M	M	I	I	PERT MODEL	
3. LOGISTICS PLAN	M	M	I	I	PERT MODEL	
4. INVENTORY REPORT	M	M	I	I	INVENTORY RECORDS	
5. EXPERIMENT REQUIREMENTS	M	M	M	M	EXPERIMENT-UNIQUE	
6. RESOURCE ALLOCATION PLANS (x)	A	A	I	I	OPTIMIZATION PROCESS	
7. MISSION FLIGHT PLAN (x)	A	A	A	A	OPTIMIZED RESULT	
8. EXPERIMENT OPERATING INSTRUCTIONS	M	M	M	M	USER DEVELOPS	
9. GROUND SUPPORT PLAN (x)	A	A	I	I	PERT MODEL	
10. MISSION TURNAROUND AND REFURBISHMENT PLAN	M	M	M	M	UNIQUE PER FLIGHT	
11. DATA REDUCTION REPORT	M	M	M	M	MISSION-UNIQUE	
12. TRAINING PLAN AND PROCEDURES	M	M	M	M	MISSION-UNIQUE	
13. INSTRUMENTATION LIST	M	M	I	I	MISSION-UNIQUE	
14. EXPERIMENT RESOURCE REQUIREMENTS (x)	A	A	I	I	SUPPORT TIMELINE ANALYSIS	
15. EMC (TEST REQUIREMENTS) PLAN	M	M	I	I	STANDARD	
16. SPACELAB USER'S GUIDE	M	M	M	M	ONE-TIME	
17. EXPERIMENTER'S DESIGN MANUAL	M	M	M	M	ONE-TIME	
18. TEST REQUIREMENTS	M	M	M	M	MISSION	
19. GSE AND FACILITIES PLAN (x)	A	A	I	I	MISSION-UNIQUE	
20. SYSTEM REQUIREMENTS MANUAL	M	M	M	M	MISSION-UNIQUE	
21. EQUIPMENT SPECIFICATIONS	M	M	I	M	MISSION-UNIQUE	
22. EQUIPMENT OPERATING INSTRUCTIONS	M	M	M	M	MISSION-UNIQUE	
23. INSTALLATION LAYOUT	M	M	M	M	MISSION-UNIQUE	
24. DESIGN INTEGRATION	M	M	M	M	MISSION-UNIQUE	
25. FAILURE SUMMARY REPORTS	M	M	M	M	MISSION-UNIQUE	
A. EXPERIMENT INSTALLATION & CHECKOUT	M	M	I	I	ENGINEERING RECORDS	
B. SPACELAB INTEGRATION	M	M	M	M	MISSION-UNIQUE	
C. CARGO INTEGRATION	M	M	M	M	MISSION-UNIQUE	

LEGEND:

- M MANUAL
- A AUTOMATED (BATCH)
- I AUTOMATED, INTERACTING
- (x) INITIAL FIVE PROGRAMS

Figure 2.4-1. Optional Processing Documentation

PROCESSES ↓	ROUTINES →																FORTRAN PROGRAM STATEMENTS (PROCESSES)	
	TRAJECTORY/ORBIT POSITION (EPHEMERIS)	PLOTTING ROUTINE	SOLAR POSITION	DATA MANAGEMENT	COORDINATE TRANSFORM	MATRIX ANALYSIS	EXPERIMENT DEFINITIONS	EXPT CONFIGURATIONS & OPERATIONS	EXPERIMENT PRIORITY	EXPERIMENT DEVELOPMENT PLANS/SCHEDULES	TERRESTRIAL/CELESTIAL POSITION	COMMUNICATION SATELLITE POSITION	ORBITER/SPACELAB CHARAC. (MASS & CONFIGURATION)	ERROR SOURCE & MAGNITUDES	SUBSATELLITE PROPERTIES & DEFINITION	MISSION PROFILES		DATA DEFINITION
EXPERIMENT GROUPINGS				X			X	X	X									500
SYSTEM/PROGRAM COST ANALYSIS				X				X		X						X		1500
GROUND TRACE GENERATOR	X	X		X	X	X												1000
TARGET OPPORTUNITY GENERATOR	X	X		X	X	X					X							1000
COMMUNICATIONS COVERAGE	X	X		X	X	X					X	X						500
SOLAR/MISSION GEOMETRY	X	X	X	X	X	X					X	X						700
RADIATION ENVIRONMENT	X	X		X						X								300
ORBIT CONTAMINATION	X	X		X			X	X		X						X		1000
ATMOSPHERE MODEL(S)	X			X			X											500
ORBIT DECAY	X			X	X	X							X					1200
ORBIT MANEUVERS	X			X	X	X					X		X					1500
ORBIT ERROR ANALYSIS	X	X		X	X	X							X					1000
SUBSATELLITE MOTION ANALYSIS	X	X		X	X	X	X	X							X			1200
MISSION CONSUMABLES				X			X						X			X		1000
ORBIT ATTITUDE MANAGEMENT	X			X	X	X		X			X							2000
INSTRUMENT POINTING	X			X	X	X		X		X	X					X		1500
MISSION TIMELINE GENERATION	X	X		X	X	X	X	X	X	X	X		X		X	X		8000
EXPERIMENT DATA PROCESSING				X	X		X	X		X						X	X	100,000
ORBIT EPHEMERIS/TIMELINE UPDATE	X	X		X	X	X												1000
CONTINGENCY OPS. PLANNING	X	X		X	X	X	X	X	X	X						X		5000
SUBSYSTEMS PERFORM. MONITOR				X			X	X	X	X						X		2500
GRND TRUTH COORD. CONTROL	X			X			X	X	X	X						X		1000
PAYLOAD (EXPMTS) STATUS MONITOR				X			X	X	X	X						X		5000
THERMAL ANALYSIS	X	X		X	X	X	X									X		3000
MASS PROPERTIES & ANALYSIS				X				X					X			X		5000
LOADS/STRESS ANALYSIS				X			X						X					5000
ELECTRICAL PWR ANAL & REQMTS				X			X	X								X		5000
DATA MANAGEMENT ANALYSIS				X												X	X	3000
STABILIZ. & CONTROL ANALYSIS				X			X						X			X		5000
																		TOTAL - 164,900
FORTRAN PROGRAM STATEMENTS (ROUTINES)	1000	500	500	5000	100	500	5000	5000	500	3000	5000	1000	5000	1000	5000	10,000	5000	TOTAL - 53,100

Figure 2.4-2. Ground Processing Size Estimates



MSFC PROGRAMS		ROCKWELL - DEFINED FUNCTIONS		EXPERIMENT GROUPINGS:																																	
				5	2	3	5	5	3	2	5	2	8	3	5	4	1,2	3,5	2	3	5	6	100	3	5	2	5	8	5	3	5	5	5	4	5	-	
TASK	PROGRAM	W	S	5	2	3	5	5	3	2	5	2	8	3	5	4	1,2	3,5	2	3	5	6	100	3	5	2	5	8	5	3	5	5	4	5	-		
ORBIT/LAUNCH TIME/DATE SELECTION EARTH OBSERVATIONS/ AMPS/SOLAR	WORLD MAP	WMAP	38																																		
	ORBITAL TRACK OPTIMIZATION	OTO	35			X																															
	PERCENT AREA COVERAGE EARTH RESOURCES	PACER	29				X																														
	PHASING	PHASE	25																																		
	RAPID OPERATION FOR MISSION PLANNING	ROMP	25				X																														
	GROUND LIGHTING ORBIT ORIENTATION	OLOO	25							X																											
	TIME OF ASCENDING AND DESCENDING SITE OBSERVATION	TADSO	18				X																														
	AMPS MISSION SIMULATOR	AMS	27																																		X
	ASTRONOMY	ASTRONOMY	ASTRON	38									X																								
		LAUNCH TIME	LANTIM	22									X																								
AVERAGE VIEWING TIME		AVTIM	38				X																														
PSEUDO STRAY LIGHT ISOCHRONAL CONTOUR		PSLIC	31				X				X									X																	
CONTINUOUS SUN LAUNCH TIME		CONSULT	15								X																										
STRAY LIGHT AND VISING EVALUATOR		SLAVE	25				X				X																										
TARGET OPPORTUNITIES	SITE ACQUISITION AND LOSS	SAL	31				X																														
	EPHEMERIS GENERATOR FOR ORBITAL EVALUATOR	EGORE	32				X	X		X	X																										
	AUTOMATIC SPACECRAFT OCCULTATION ROUTINE	ASOR	28					X		X																											
	SENSOR TARGET OCCULTATION PROGRAM (SLAVE)	STOP (SLAVE)	32					X		X										X	X															X	
	(PSEUDO STRAY LIGHT ISOCHRONAL CONTOUR)	(PSLIC)	31				X			X																											
	ORBIT CHARACTERISTICS/ ENVIRONMENT	ANALYTIC SATELLITE EPHEMERIS PROGRAM	ASEP	32				X		X				X	X																						
ORBITAL LIFETIME		LIFTIM	32										X	X					X																		
RELATIVE MOTION		REL	17																																		
RADIATION MODEL		RADI	30										X																								
RADIATION CALCULATION		RADCAL	17										X	X																							
ORBIT ENVIRONMENT SUMMARY		OES	30				X	X		X																											
CLOUD MODEL		CLOUD	30											X																							
ATTENUATION MODEL		ATTEN	25				X							X																							
SHUTTLE PERFORMANCE	INSERTION SURFACE	INFACE	22																																		
	INTEGRATED MISSION PROGRAM	IMP	32																																		
	PERFORMANCE CALCULATIONS	PERCAL	25																																		
	DEBOOST OPPORTUNITY PROGRAM	DEBOP	26																																		
PAYLOAD ACTIVITY SCHEDULING	SOLAR PHYSICS AND EARTH RES EXP SCHEDULER	SPERES	32	X																			X														
	STELLAR TARGET SCHEDULER	SCREAM	32	X																			X														
	AMPS MISSION SCHEDULER	AMPS	-	X																			X														
	CREW TIMELINE	CREWTL	24	X																			X														
	GENERAL ACTIVITY SCHEDULER	WAMPUM	22	X																			X														
	TIMELINE INTEGRATOR	TINT	48	X																			X														
	MISSION OPERATIONS SEQUENCE SUMMARY	MOSS	15																				X														
	DATA STORAGE PROFILE	DASPRO	32	X																			X														
	ATTITUDE TIMELINE INTEGRATOR	ATINT	38	X																			X														
	FLIGHT PLAN SUMMARY	FPS	24																				X														
SYSTEM/ SUB-SYSTEM ANALYSIS	GRAPHICS LAYOUT	AIDS	32	X																																	
	MASS PROPERTIES	MASS	25	X																			X														
	SHUTTLE PAYLOAD INTERFACE LOADS	SPL	3	X																																	
	THERMAL MODAL NETWORKS ANALYSIS	STINDA	45	X																																	
	THERMAL RADIATION ANALYSIS	TRASYS	45	X																			X														
	POINTING CONTROL SIMULATION	IPS	20																				X														
	SPACELAB CONTAMINATION MODEL	CONTAM	53	X																																	
UNKNOWN CORRELATION																																				X	

5 STATEMENTS (K)
5 WORDS (K)

Figure 2.4-3. Ground Processing Software Availability (MSFC)



The 29 essential programs for ground operation processes and the five programs for documentation comprised the data base for the subsequent analyses. The recompilation cost of \$700K was used in the programmatic costing analysis. However, this magnitude of cost is quite unlikely. The trend in the computer industry is to achieve hardware and software interchangeability between vendors with minimal effort.

2.5 GROUND PROCESSING IMPLEMENTATION COST FACTORS

The alternatives for computerized ground processing activities are essentially the same as those for on-board services. A *batch processing* approach can be used wherein the user requirements are documented and exercised by a *centralized* data processing center (DPC). Or, an *interactive terminal* approach can be used wherein the user communicates directly with what appears to be a *dedicated* processor via a CRT/keyboard. These two approaches are illustrated in Figure 2.5-1, and the two formats of the initialization data are illustrated in Figure 2.5-2. (It should be noted that in the case of ground processing, existing computer software is being exercised--not developed; software is being developed in the case of on-board services.)

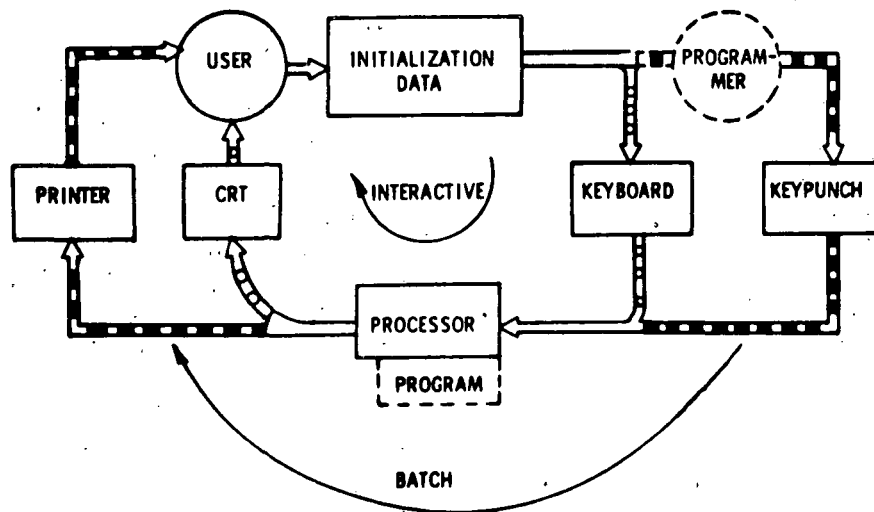

Figure 2.5-1. Interactive/Automatic (Batch) Concept

BATCH PROCESSING

With the batch processing approach, the user completes initialization data forms similar to that shown on the right side of Figure 2.5-2. These forms are transferred to a centralized activity which keypunch/machine codes the data and exercises the appropriate program. Printed results are returned

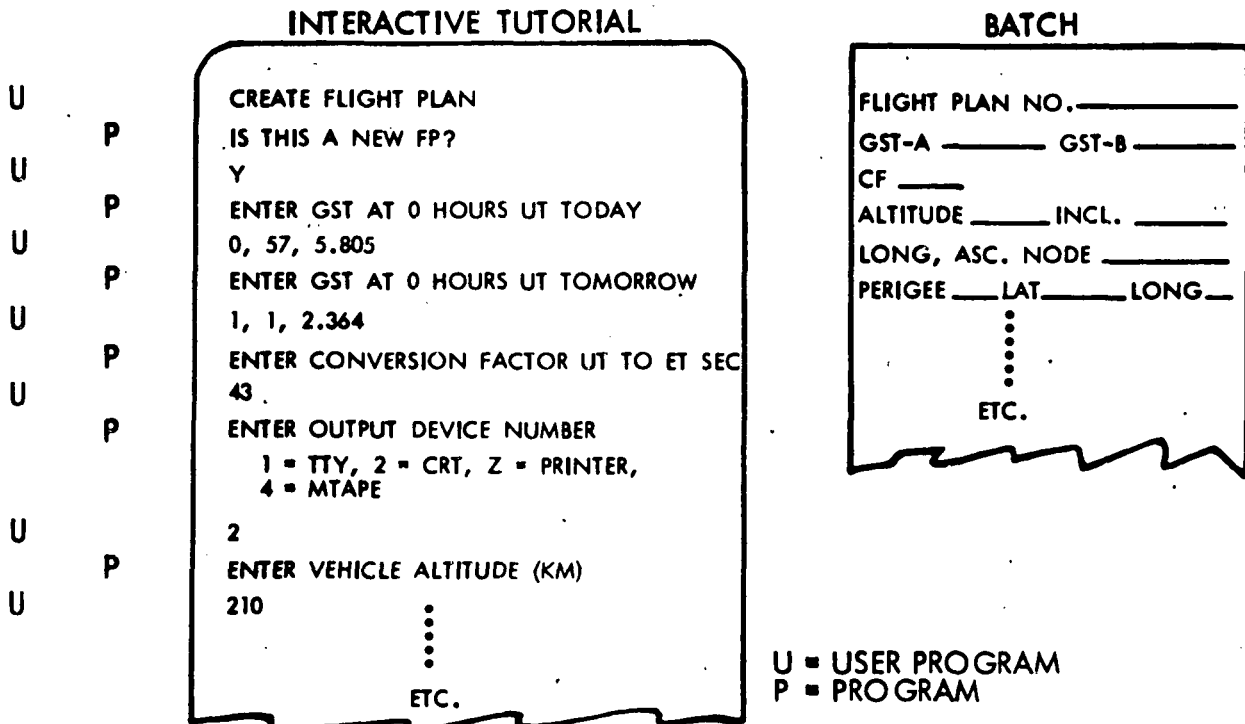

Figure 2.5-2. Ground Processing Tutorial Requirements

to the user. The factors to be considered with the batch processing approach include average number of computer runs per flight per program, data processing center personnel requirements, turnaround time, and host machine time. Table 2.5-1 summarizes these considerations and reflects estimates based upon previous programs at Rockwell of a similar nature. Thus, with the batch processing, or *centralized* approach, the per-flight costs are about \$82K. If the data processing center at Langley is used the turnaround time is at least one day. Even this delay between data request and output data can be frustrating to a mission analyst. Note that for the projected ATL program the DPC utilization rate is only 5.7 percent for two flights per year. It was assumed that this rate can be accommodated by existing DPC capabilities.

INTERACTIVE TERMINAL PROCESSING

With the interactive terminal approach the user *communicates* directly with the processor via a CRT/keyboard by means of tutorial software. The left side of Figure 2.5-2 illustrates a typical CRT display in the exercising of the interactive terminal approach.

There were five alternative implementations of the interactive terminal approach that were evaluated. Two concepts pertain to remote terminals and three to dedicated mini-processors. The remote terminal concepts are illustrated in Figure 2.5-3. In one case the DPC was considered to be at Langley; in the other case the DPC was considered to be at KSC, the Level III/II/I Spacelab integrator. With the local DPC, initial installation/purchase of a remote terminal is the only capital investment (\$3K); the recurring costs are



Table 2.5-1. Batch Processing Considerations

- ESSENTIAL PROGRAMS: 29
- OPTIONAL PROGRAMS: 5
- ESTIMATED AVERAGE RUNS PER FLIGHT: 20 TIMES EACH
 $34 \times 20 = 680$ RUNS
- PROGRAMMING TEAM
 - 1 LEAD PROGRAM ANALYST @ \$50K/YEAR
 - 1 CODER (KEYPUNCH OPERATOR) @ \$40K/YEAR
- ESTIMATED RUN RATE PER TEAM: 4/DAY
 $680 \div 4 = 170$ DAYS/FLIGHT
 $(50K + 40K) \times \frac{170}{250} = \$61.2K/\text{FLIGHT}$ (250 WORKING DAYS/MAN-YEAR)
- TURNAROUND TIME PER RUN
 - LOCAL: 3 WORKING DAYS (NASA SPEC. HANDLING)
 - REMOTE: 10 WORKING DAYS (U.S. POSTAL SERVICE)
- HOST MACHINE TIME
 - AVERAGE CLOCK TIME/RUN: 5 MINUTES
 - 680 (RUNS) \times 5 (MIN) \div $600 \approx 57$ HR MACHINE TIME PER FLIGHT
- HOST MACHINE COSTS
 - AVERAGE COSTS/HOUR: \$375 (S/360)
 - $57 \times \$360 = \$21K/\text{FLIGHT}$
- HOST MACHINE UTILIZATION
 - AVAILABLE HOURS PER YEAR: 2000
 - @ 2 FLIGHTS/YEAR $\frac{114}{2000} \times 100 = 5.7\%$
- PER-FLIGHT COSTS
 - PROGRAMMING TEAM + HOST MACHINE
 - \$61.2K + \$21K = \$82.2K/FLIGHT

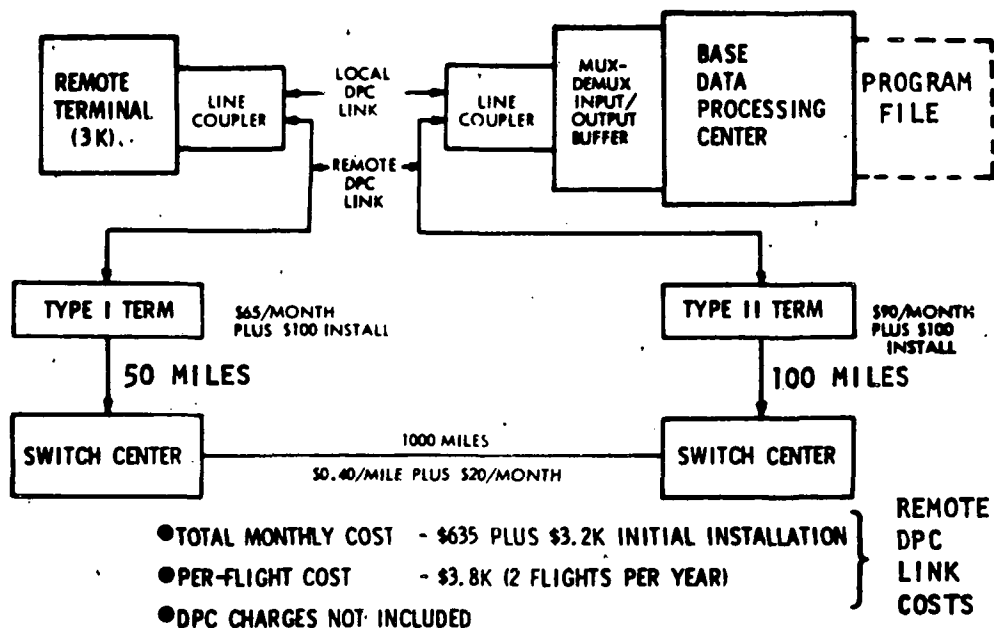

Figure 2.5-3. Remote Terminal Alternatives

the host machine time and are the same as the batch processing approach--\$21K per flight. If the DPC is at KSC, an additional installation (\$200) and monthly service charge (\$635) is involved for the Dataphone Digital Service links required between Langley and KSC.

The three dedicated mini-processor implementations consisted of minor variations in the memory configuration. One system, the *mini-common disc*, utilized a disc memory bank that was shared by all users. The two other configurations, *mini-dedicated tape* and *mini-dedicated disc* individualized the memory systems for each user. All three systems could utilize the same mini-processor and interactive terminal (\$18K). The memory systems were \$28K, \$15.4K, and \$19K for the common-disc, dedicated-tape, and dedicated-disc configurations, respectively. The difference between the two dedicated systems is simply one uses a tape memory; the other uses a disc memory. The common-disc memory configuration is a one-time investment. The other two memory configurations must be acquired with the mini-processors as the traffic/work-levels increase beyond two flights per year.

SUMMARY

Programmatic costs for the five ground processing implementation concepts are summarized in Table 2.5-2. Yearly costs reflect the ATL flight rate for the baseline traffic model and are accumulated, arbitrarily, in the year prior to the scheduled flight. Batch processing costs are prohibitive and are the largest even in the first year of the program. The costs of the remote-terminal concepts and the mini-processor concepts are comparable initially, but rapidly accumulate to significantly more than the mini-processor concepts. Thus, the mini-processor concepts are preferred. Of the three, the *mini-dedicated disc*

Table 2.5-2. Implementation Cost Comparison

YEAR OF FLIGHT	1980	1981	1982	1983	1984	1985	1986	1987	1988	1989	1990	1991	PROGRAM TOTAL
NO. OF FLIGHTS		1	1	2	3	3	3	4	4	4	5	5	
BATCH ^{1,2} (NON-TUTORIAL)	82	82	164	246	246	246	328	328	328	410	410	-	\$2870K (\$82K/FLIGHT)
REMOTE TERMINAL TO LOCAL DPC ^{2,3}	* 24	21	* 45	* 66	63	63	* 87	84	84	* 108	105	-	\$750K (\$15K NON-RECURRING) (\$21K/FLIGHT)
REMOTE TERMINAL TO REMOTE DPC ^{2,3,4}	* 32	29	* 53	* 74	71	71	* 95	92	92	* 116	113	-	\$838K (\$15K NON-RECURRING) (\$29K/FLIGHT)
MINI-COMMON DISC ⁵	* 46	-	* 30	* 30	-	-	* 30	-	-	* 30	-	-	\$166K
MINI-DEDICATED TAPE ⁵	* 33	-	* 33	* 33	-	-	* 33	-	-	* 33			\$165K
MINI-DEDICATED DISC ⁵	* 37	-	* 37	* 37	-	-	* 37	-	-	* 37	-	-	\$185K

¹PROGRAMMER TEAM, SALARY PER FLIGHT AT \$61K.
²ALL CONCEPTS USING DPC CHARGED \$21K PER FLIGHT (57 HOURS OF RUN TIME X \$375).
³ONE REMOTE TERMINAL PER FLIGHT PER YEAR AT \$3K.
⁴DATAPHONE DIGITAL SERVICE CHARGE AT \$635/MONTH.
⁵ONE MINI SET PER FLIGHT PER YEAR.
*REQUIRED CAPITAL INVESTMENT/EQUIPMENT PURCHASE.

2-25

SD 76-SA-0028-1



concept is favored because of the versatility and flexibility that is characteristic of this approach. Also, it is believed that more efficient operations (less manpower) can be achieved with the dedicated approach. These advantages warrant the minor additional costs of \$20K for a 10-year program. It should be noted that this recommendation is based upon the assumption that the GSSS/MSFC programs will be compiled for an applicable mini-processor at nominal cost--not the worst case estimate of \$700K.

2.6 PROGRAMMATIC EVALUATION

ATL programmatic costs were developed, based upon the recommended approaches for mandatory on-board computerized services (maximize the dedicated processor approach), command/control operations (use computer-aided approach when reasonable), and ground processing/mission planning activities (implement a dedicated mini-processor/disc memory concept). A representative ATL payload model was synthesized, and hardware and software cost factors for this typical payload were defined. Costs were developed for three different traffic models, considering potential reuse and reflight of both hardware and software. As the preferred approaches to software-related activities were dependent upon the availability of an FSSS and GSSS, a contingency/criticality analysis was conducted to identify the impact of the lack of these two proposed software *tools*.

REPRESENTATIVE ATL PAYLOAD AND COST FACTORS.

The three reference ATL payloads indicated that multiple Spacelab configurations would be used, and significant variations in on-board operations and experiment reflight would occur. In order to develop ATL programmatic costs a representative ATL payload model was formulated. The analyses of required on-board computer services indicated that a typical ATL payload would require six mini-processors, 14 micro-processors and 2500 statements of mission-unique flight applications software. However, the reference ATL payloads had 11, 11, and 12 experiments each. Therefore, control panel and computer-aided command/control equipment and software requirements were derived to reflect the total complement of experiments on an ATL payload.

Analyses of the 25 reference ATL experiments indicated that not all of them could or would be controlled from a common work station. The experiments were categorized into four groups according to their complexity of manned operations and man-machine interface characteristics (see Table 2.6-1). The experiments in Group 1 required extensive command/control/monitor operations. Although the experiments in Group 2 were highly automated, a significant man-machine control/monitor interface was still required. The experiments in Group 3 required only initiate/terminate control actions. The group 4 experiments required direct man-participation, involving manual dexterity and/or visual acuity.

The operational characteristics of the first two groups of experiments are readily adaptable to the computer-aided command/control approach. The fourth group of experiments are not adaptable to the computer-aided approach. Although the third group of experiments could be adapted to the computer-aided approach the control actions are simple, non-repetitive, and require minimal monitoring; this group is not recommended for computer-aided command/control implementation.



Table 2.6-1. Man-Machine Interface Grouping

GROUP 1	EXTENSIVE CONTROL & MONITOR REQUIRED
	<ul style="list-style-type: none"> • NV-1 MICROWAVE INTERFEROMETER • NV-2 AUTONOMOUS NAVIGATION • NV-3 MULTIPATH MEASUREMENTS • EO-2 TUNABLE LASERS • EO-4 MICROWAVE RADIOMETER • EO-5 LASER RANGING & ALTIMETRY • EO-6 MICROWAVE LATIMETER • EO-7 SEARCH & RESCUE AIDS • EO-8 IMAGING RADAR • EO-9 RF NOISE MEASUREMENT
GROUP 2	HIGHLY AUTOMATED BUT EXTENSIVE MONITORING/EVALUATION REQUIRED
	<ul style="list-style-type: none"> • EO-1 LIDAR MEASUREMENTS • EO-3 MULTISPECTRAL SCANNER • PH-4 NEUTRAL GAS PARAMETERS
GROUP 3	HIGHLY AUTOMATED, ONLY INITIATE/TERMINATE ACTIONS REQUIRED
	<ul style="list-style-type: none"> • PH-6 METEOR SPECTROSCOPY • MB-1 COLONY GROWTH • EN-3 NON-METALLIC MATERIALS • CS-2 ZERO-G STEAM GENERATOR • CS-X CONTAMINATION MONITOR
GROUP 4	DIRECT MAN PARTICIPATION, DEXTERITY, VISUAL ACUITY REQUIRED
	<ul style="list-style-type: none"> • PH-2 BARIUM CLOUD RELEASE • PH-3 AEROSOL OPTICAL PROPERTIES • MB-2 MICRO-ORGANISM TRANSFER • MB-3 BIOCELL ELECTRICAL FIELD OPACITY • MB-4 BIOCELL ELECTRICAL CHAR. • MB-5 BIOCELL SPECIAL PROPERTIES • EN-5 MICRO-ORGANISM SAMPLING

The experiments in Groups 1 and 2 correlate with those for which dedicated mini-processors for the on-board services were identified. Thus, it was postulated that six experiments of the nominal payload would include the computer-aided command/control concept.

As the average number of experiments in the reference ATL payloads was 11, an allowance for hardwired control panels was also made. Several of the experiments in Groups 3 and 4 pertain to microbiology and require either no controls or minimal controls. In order to reflect the averaging effect of this class of experiments it was postulated that four hardwired control panels would be required for each ATL payload and would cost approximately \$3K each. (The average panel cost if all controls were hardwired was \$5K.)

Typical ATL payload hardware requirements are summarized in Figure 2.6-1. The display terminals and printers that are allocated to the PI's are for development/validation of flight software. Two additional display terminals were allocated to the lead center and would be the actual common-work-station flight hardware. The remote activation systems are associated with the six experiments that would utilize the computer-aided command/control approach. The mini-disc sets are allocated to the lead center to support the mission planning activities.

Software cost factors are summarized in Figure 2.6-2. The recurring costs include the preparation of the flight applications software for both the mini- and micro-processors for all the experiments on a payload. Command/control services reflect the use of the computer-aided approach in the mechanization of six experiments. The CDMS services are associated with the integration of telemetry, caution and warning, data annotation, and mission timelines with the Spacelab and Orbiter.



PI ALLOCATION		LEAD CENTER ALLOCATION	
● MINI-PROCESSOR SYSTEMS		● MINI-DISC SETS	
→ ● 6 MINI-PROCESSORS	\$ 168 K	● 2 MINI-PROCESSOR	\$ 31 K
● 6 DISPLAY TERMINALS	\$ 18 K	● 2 DISPLAY TERMINAL	\$ 6 K
● 6 PRINTERS	\$ 12 K	● 2 PRINTER	\$ 4 K
→ ● 14 MICRO-PROCESSORS	\$ 154 K	● 2 DISC MEMORY	\$ 32 K
→ ● COMMAND/CONTROL DEVICES		● FLIGHT COMMAND/CONTROL	
● 6 REMOTE ACTIVATION SYS.	\$ 3.6 K	● 2 DISPLAY TERMINALS	\$ 6 K ←
● 4 CMD/CONTROL PANELS	\$ 12 K		
SUPPORTS 2 FLIGHTS PER YEAR			

→ FLIGHT HARDWARE

Figure 2.6-1. Typical ATL Payload Hardware Complement

RECURRING ON-BOARD SERVICES (PER PAYLOAD)	NON-RECURRING SOFTWARE DEVELOPMENT TOOLS
MANDATORY COMPUTER SERVICES 2500 STATEMENTS @ \$31/ \$ 77.5 K	FLIGHT SOFTWARE SUPPORT SYSTEM \$ 680 K (1)
COMMAND/CONTROL SERVICES 1200 STATEMENTS @ \$31/ \$ 37.2 K 72K BYTES (DATA TABLES) @ \$.01/ \$ 0.7 K	COMMAND/CONTROL DELTA TO FSSS 1200 STATEMENTS @ \$62/ \$74.4 K
CDMS SERVICES 300K BYTES (DATA TABLES) @ \$.01/ \$ 3.0 K 3 HR HOST MACHINE TIME @ \$375/ \$ 1.1 K 3 MAN-MO. INTEGRATION \$ 12.5 K	GROUND SOFTWARE SUPPORT SYSTEM DELTA \$700 K (2)

- (1) AGENCY DEVELOPMENT
(2) WORST CASE ESTIMATE; COMPLETION OF MSFC PROJECT COULD ALMOST ELIMINATE THIS ITEM.

Figure 2.6-2. Software Programmatic Complement

Non-recurring software costs are for the development of the basic FSSS and the delta to the FSSS to efficiently utilize the computer-aided command/control approach, and to convert/modify existing/in-work mission planning software at MSFC to Langley's specific use. Because of the broad application of the FSSS it is recommended that its development be sponsored by the agency --not uniquely attributed to ATL. Upon completion of the GSSS work at MSFC, this software development tool may also be directly applicable to ATL payloads.



PROGRAMMATIC COSTS

In order to develop programmatic costs it was necessary to establish guidelines for ATL flight rates and reflight commonality for both hardware and software. Figure 2.6-3 summarizes the selected guidelines. Three ATL traffic models were used: the baseline (*Yardley* traffic model), maximum of two flights per year, and a one-flight-per-year program.

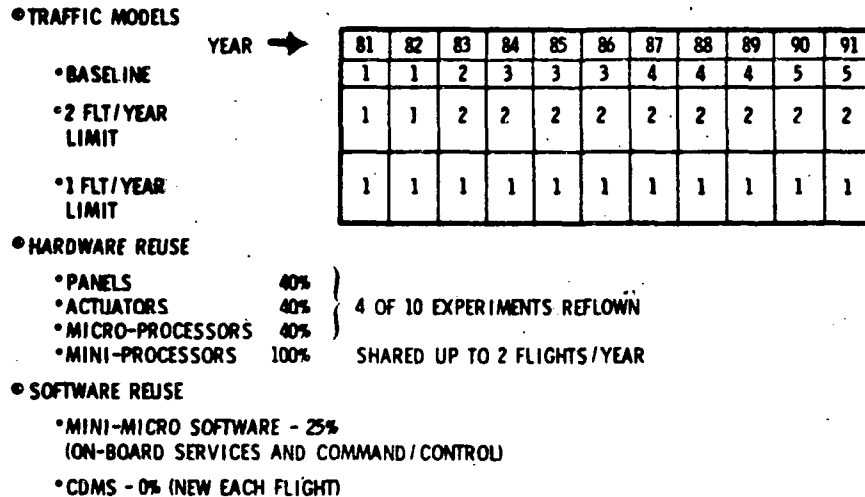

Figure 2.6-3. Programmatic Costing Criteria

As panels, actuator hardware, and micro-processors are an integral part of the experiment equipment, sharing of these end items between experiments was not considered to be practical. However, experiment reflights are anticipated. Thus, it was assumed that the reuse of this type of hardware would average 40 percent during the course of the ATL program. Mini-processors are *stand-alone* end items and can be shared between experiments. Thus, 100-percent reuse was assumed. Each mini-processor can support two flights per year. It is anticipated that a limited amount of flight applications software will also be reusable. A 25-percent software reuse factor was estimated. As the experiment mix of each ATL payload is different each flight, it was assumed that the CDMS integration effort (\$16.6K per flight) would be required for each flight.

Based upon these cost factors and reuse criteria, a compilation of the programmatic software-related costs for each ATL traffic model was developed as illustrated in Tables 2.6-2, 2.6-3, and 2.6-4. Cumulative recurring costs (basic FSSS, command/control delta, and GSSS mods not included) are plotted for the three traffic models in Figure 2.6-4. The minor per-flight variations between traffic models are due to different utilization rates of the mini- and micro-processors and the intelligent terminals.

Table 2.6-2. Program Cost Summary - Baseline ATL Traffic Model (\$K)

YEAR OF FLIGHT		1978	1979	1980	1981	1982	1983	1984	1985	1986	1987	1988	1989	1990	1991
NO. OF FLIGHTS					1	1	2	3	3	3	4	4	4	5	5
ON-BOARD PROCESSING	ON-BOARD HARDWARE														
	MINI-PROCESSORS			168			168						168		
	MICRO-PROCESSORS			154	92	185	277	277	277	370	370	370	462	462	
	ACTIVATION SYSTEMS			4	2	5	7	7	7	10	10	10	12	12	
	CONTROL PANELS			12	7	14	22	22	22	29	29	29	36	35	
	INTELLIGENT TERMINALS			6			6						6		
	ON-BOARD SOFTWARE														
	MANDATORY			78	47	94	140	140	140	187	187	187	234	234	
	COMMAND/CONTROL			38	23	46	68	68	68	91	91	91	114	114	
	CDMS			17	17	34	51	51	51	68	68	68	85	85	
TOTAL			477	188	378	739	565	565	755	755	755	1117	943		
SUPPORT HARDWARE															
DISPLAY TERMINAL - PRINTERS			30			30							30		
SUPPORT SOFTWARE															
FSSS BASIC	300	300													
FS3 CMD/CONT DELTA		75													
TOTAL	300	375	30			30							30		
GROUND PROCESSING															
MINI-DISC SETS			37		37	37				37			37		
GSSS MODIFICATIONS	250	250	200												
TOTAL	250	250	237		37	37				37			37		
COMPOSITE TOTALS	550	625	744	188	415	806	565	565	792	755	755	1184	943		

2-30

SD 76-SA-0028-1



Rockwell International
Space Division

Table 2.6-3. Program Cost Summary - 2 Flights/Year Limit (\$K)

YEAR OF FLIGHT		1978	1979	1980	1981	1982	1983	1984	1985	1986	1987	1988	1989	1990	1991
NO. OF FLIGHTS					1	1	2	2	2	2	2	2	2	2	2
ON-BOARD PROCESSING	ON-BOARD HARDWARE														
	MINI-COMPUTERS			168											
	MICRO-COMPUTERS			154	92	185	185	185	185	185	185	185	185	185	185
	ACTIVATION SYSTEMS			4	2	5	5	5	5	5	5	5	5	5	5
	CONTROL PANELS			12	7	14	14	14	14	14	14	14	14	14	14
	INTELLIGENT TERMINALS			6											
	ON-BOARD SOFTWARE														
	MANDATORY			78	47	94	94	94	94	94	94	94	94	94	94
	COMMAND/CONTROL			38	23	46	46	46	46	46	46	46	46	46	46
	CDMS			17	17	34	34	34	34	34	34	34	34	34	34
TOTAL			477	188	378	378	378	378	378	378	378	378	378	378	
ON-BOARD PROCESSING	SUPPORT HARDWARE														
	DISPLAY TERMINAL - PRINTER			30											
	SUPPORT SOFTWARE														
	FS ³ BASIC	300	300												
	FS ³ CMD/CONT DELTA		75												
TOTAL	300	375	30												
GROUND PROCESSING	MINI-DISC SETS			37		37									
	GSSS MODIFICATIONS	250	250	200											
	TOTAL	250	250	237											
COMPOSITE TOTALS		550	625	744	188	415	378	378	378	378	378	378	378	378	

2-31

SD 76-SA-0028-1



Rockwell International
Space Division

Table 2.6-4. Program Cost Summary - 1 Flight/Year Limit (\$K)

YEAR OF FLIGHT		1978	1979	1980	1981	1982	1983	1984	1985	1986	1987	1988	1989	1990	1991
NO. OF FLIGHTS					1	1	1	1	1	1	1	1	1	1	1
ON-BOARD PROCESSING	ON-BOARD HARDWARE														
	MINI-COMPUTERS			168											
	MICRO-COMPUTERS			154	92	92	92	92	92	92	92	92	92	92	92
	ACTIVATION SYSTEMS			4	2	2	2	2	2	2	2	2	2	2	2
	CONTROL PANELS			12	7	7	7	7	7	7	7	7	7	7	7
	INTELLIGENT TERMINALS			6											
	ON-BOARD SOFTWARE														
	MANDATORY			78	47	47	47	47	47	47	47	47	47	47	47
	COMMAND/CONTROL			38	23	23	23	23	23	23	23	23	23	23	23
	CDMS			17	17	17	-17	17	17	17	17	17	17	17	17
TOTAL			477	188	188	188	188	188	188	188	188	188	188	188	
ON-BOARD PROCESSING	SUPPORT HARDWARE														
	DISPLAY TERMINAL - PRINTER			30											
	SUPPORT SOFTWARE														
	FSSS BASIC	300	300												
FS ³ CMD/CONT DELTA		75													
TOTAL	300	375	30												
GROUND PROCESSING	MINI-DISC SETS			37											
	GSSS MODIFICATIONS	250	250	200											
	TOTAL	250	250	237											
COMPOSITE TOTALS	550	625	744	188	188	188	188	188	188	188	188	188	188	188	

2-32

SD 76-SA-0028-1

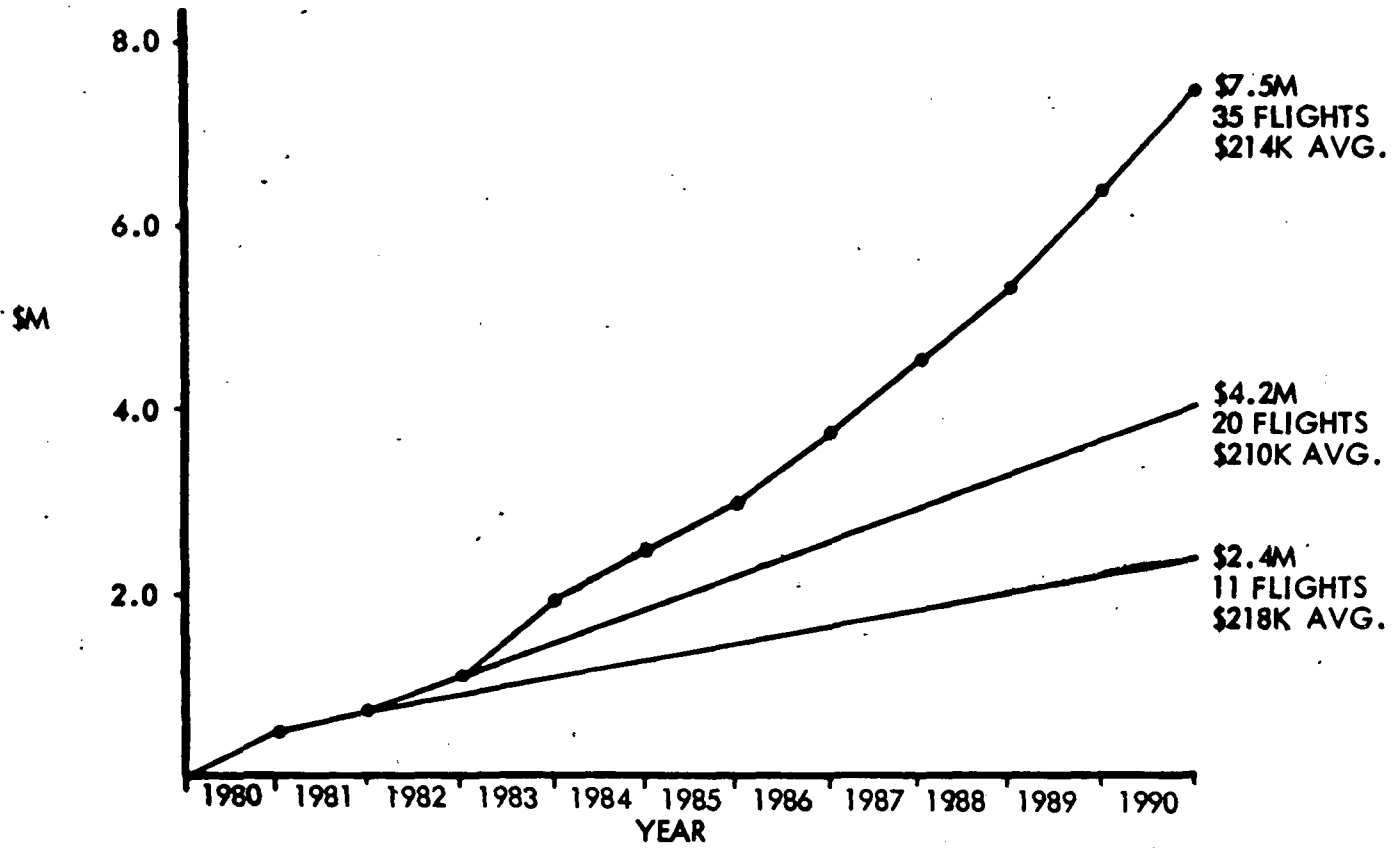

Figure 2.6-4. Cumulative Recurring Cost Summaries



CONTINGENCY EVALUATION

The preferred approaches for on-board services, command/control functions, and ground processing were based upon the development of the FSSS and the adaptation of the MSFC software programs to a GSSS. A contingency evaluation was conducted to assess the impact if the FSSS and GSSS were not developed. The impact on the initial ATL flights is summarized in Table 2.6-5.

Table 2.6-5. Contingency Evaluation

		FIRST FLIGHT COSTS		
		WITHOUT FSSS	WITH FSSS	COMMENTS
ON-BOARD OPS		<ul style="list-style-type: none"> • MINI/MICRO S/W \$ 375 K • CDMS SOFTWARE 17 K • PI HARDWARE 397 K • LEAD CENTER HDW 6 K <li style="text-align: right;">TOTAL \$ 795 K 	<ul style="list-style-type: none"> • MINI/MICRO S/W \$ 115 K • CDMS SOFTWARE 17 K • PI HARDWARE 368 K • LEAD CENTER HDW 6 K <li style="text-align: right;">TOTAL \$ 512 K 	<ul style="list-style-type: none"> • FSSS = \$755K • SAVINGS USING FSSS FOR 3-4 FLIGHTS EQUALS FSSS COSTS
	GROUND OPERATIONS		<p>WITHOUT LOCAL GSSS</p> <ul style="list-style-type: none"> • BATCH PROCESSING \$ 82' K • REMOTE TERMINAL \$ 32 K 	<p>WITH LOCAL GSSS</p> <ul style="list-style-type: none"> • MINI-DISC APPROACH \$ 36.5 K

Without the FSSS the PI must develop his flight applications software, including all the library routines, independently. This effort will increase the quantity of required on-board services software for each mission by about 9600 statements. However, without the FSSS the computer-aided command/control approach would be impractical to implement, and the computer-aided software (1200 statements) would not be developed. Thus, the net increase in software would be 8400 statements. Assuming adequate programmer support is available for working directly with the PI (informal relationship/minimal documentation) these additional statements will cost \$31 each and add \$260K to the cost of experiment software.

Even if the problems/complexity/costs associated with the required integration of control panels for the pallet-only configuration are neglected, the average payload hardware costs will increase without the computer-aided approach. With the FSSS (and computer-aided approach), \$16K of the hardware costs was for activation system hardware and simple control panels (\$352K was for processors). Without the FSSS all experiments will require hardwired panels at an average cost of \$5K/experiment, or \$50K/payload. Therefore, the total software development and related hardware costs for the first ATL payload will be \$293K greater

without the FSSS than with the FSSS. If the same software and hardware reuse criteria were used for the ATL traffic model without the FSSS, the delta programmatic costs after four ATL flights would be greater than the development costs of the FSSS.

Implementation of a local GSSS capability with the mini-disc computer system is not time-critical. Use of a remote terminal approach results in, essentially, a recurring \$32K/flight cost; the mini-disc approach is a non-recurring capital investment of \$37K.

2.7 PALLET-ONLY CONFIGURATION SPECIAL CONSIDERATIONS

In general, the analyses and trades of alternate mechanizations of on-board operations were conducted without consideration of the specific Spacelab configuration involved. If the pallet-only configuration is uniquely considered, then the limited control panel space in the Orbiter aft-flight-deck (AFD) becomes a prime driver in the mechanization of experiment command/control/monitor functions. The baseline Orbiter *payload* panel allocation in the Orbiter AFD is illustrated in Figure 2.7-1. This area must be shared by the Spacelab (subsystem controls) and the experiments. The baseline panel space allocation for operation of Spacelab systems utilizes 1432 in² of the 3200 in² (shaded area) available for Orbiter payloads. Thus, only the cross-hatched area (1768 in²) is available for ATL experiment control panels.

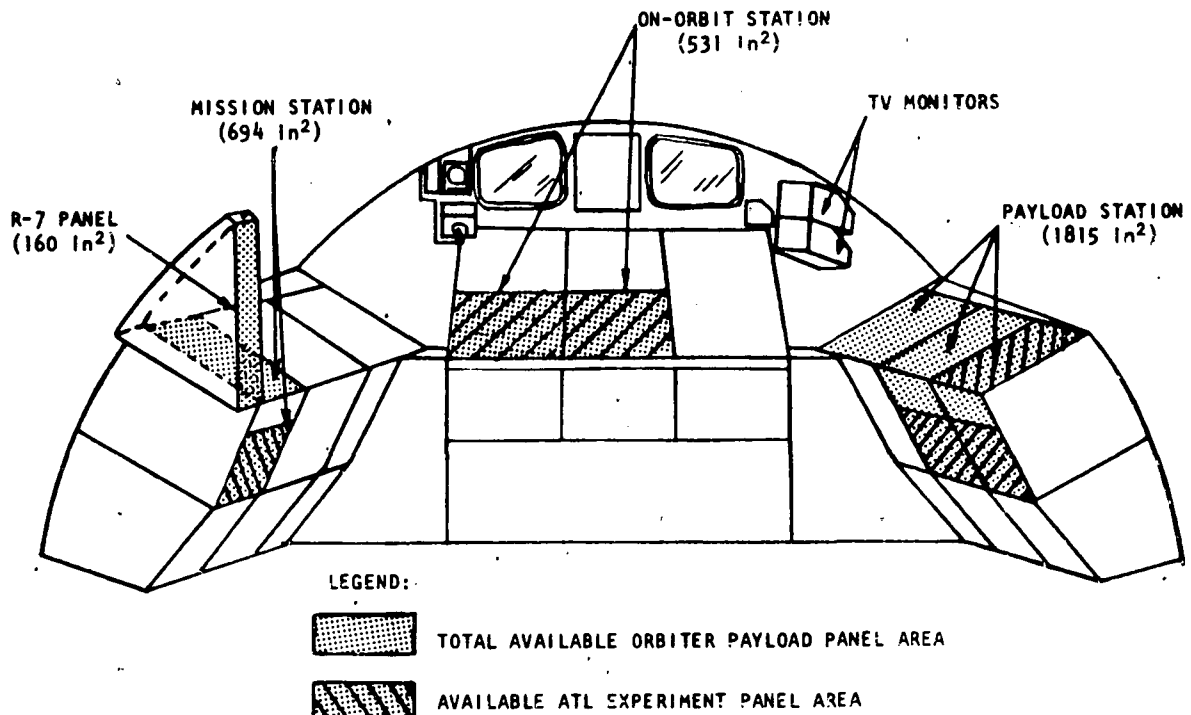

Figure 2.7-1. AFD Panel Allocation for Orbiter Payloads



Table 2.7-1 summarizes the required dedicated command/control panel areas for the experiments of the reference pallet-only ATL payload. In addition, dedicated displays (spectrum analyzers, oscilloscopes, etc.) are required by several of the ATL experiments and are also indicated in the table. Even if the TV monitors (see Figure 2.7-1) are shared between experiment, Spacelab, and Orbiter operations, the dedicated displays/monitors increase the required ATL AFD panel area to 2161 in², which obviously exceeds the available space. By adopting the computer-aided command/control approach for the first seven ATL experiments listed in Table 2.7-1 (these seven experiments required mini-processors for the mandatory on-board computer services), the required AFD panel space would be reduced by 950 in². Making an allowance of 342 in² for a dedicated intelligent terminal for experiment operations would result in a total ATL experiment panel requirement of 1563 in², which is compatible with the available space.

Table 2.7-1. ATL Pallet-Only Payload-Required Hardwired Panel Space
(Thousands of Dollars)

	EXPERIMENT	COMMAND/ CONTROL AREA (IN ²)	TV MONITOR	DEDICATED DISPLAY AREA (IN ²)
EXTENSIVE COMMAND, CONTROL, & MONITOR REQUIRED	NV-1 MICROWAVE INTERFEROMETER	95	*	
	NV-2 AUTONOMOUS NAVIGATION	171	*	152
	EO-4 RADIOMETER	209	*	152
	EO-7/8 SEARCH & RESCUE/IMAGING RADAR	209	*	152
	EO-1 LIDAR MEASUREMENT	133	*	152
	PH-4 NEUTRAL GAS PARAMETERS	133		152
MANUAL DEXTERITY & VISUAL ACUITY REQUIRED	PH-6 METEOR SPECTROSCOPY	95		
	EN-3 NON-METALLIC MATERIALS	133		
	CS-X CONTAMINATION MONITOR	133		
	PH-2 BARIUM CLOUD RELEASE	247	*	
	EN-1 MICRO-ORGANISM SAMPLES	95		
TOTAL		1653	*	508
*SHARE TV WITH SPACELAB AND ORBITER OPERATIONS.				

In this analysis, only total panel areas were considered. If actual dedicated panel layouts and interference between top-mounted and front-mounted panels are considered, the accommodation margin will be reduced if not eliminated. Thus, in actual practice, it may be necessary to implement the computer-aided approach in additional experiments and/or limit the experiments on a pallet-only Spacelab to those that are compatible with the computer-aided command/control approach.

A cost analysis of the two command/control approaches for the reference ATL pallet-only payload was conducted (Table 2.7-2). Dedicated panel costs would be almost \$58K. In addition to the dedicated panels for the last five



experiments of Table 2.7-2, activation hardware for implementation of the computer-aided approach for the first seven experiments would cost \$4.2K (\$600 per experiment). Software and data tables for these seven experiments would cost an additional \$44K. Thus, the computer-aided approach would cost about \$15K more. It is believed that this delta cost for implementing the computer-aided approach is warranted. If non-dedicated hardwired control panels were utilized to meet the AFD space limitations, it is anticipated that the costs of integration of multiple experiment requirements into a single panel and the duplicate fabrication of these panels for Level IV integration activities will greatly exceed the \$15K figure.

Table 2.7-2. Cost Comparison of Command/Control Approaches for Reference Pallet-Only ATL Payload

EXPERIMENTS	HARDWIRED APPROACH	COMPUTER-AIDED APPROACH	
	PANELS	HARDWARE	SOFTWARE
NV-1	2.8	} 4.2	44.1
NV-2	5.3		
EO-4	7.0		
EO-7/8	7.0		
EO-1	7.0		
PH-4	4.2		
PH-6	4.0		
EN-3	2.2	} 24.7	-
CS-X	3.7		
PH-2	12.1		
EN-1	2.7		
	57.9	73.0	



3.0 PROGRAMMATIC SOFTWARE-RELATED RECOMMENDATIONS

Throughout the analyses the primary objectives have been to maintain autonomy of individual experiments, maximize hardware and software reuse, and minimize programmatic costs. The results not only reflect these factors but also indicate that they are compatible. In this section, guidelines for the development of ATL payloads that will assist in the achievement of these objectives are delineated.

FLIGHT OPERATIONS CONSIDERATIONS

Develop the basic flight software support system. Analyses indicate that for a continuing program such as the ATL, significant cost savings can be realized if a software development *tool* is used. The proposed concept will minimize the mission-unique software that is required.

Maximize the use of on-board experiment-dedicated mini/micro-processors. The cost savings in software development that can be achieved if dedicated processors are used warrants the slight weight, power, volume, and costs of these processors. The PI's autonomy and flexibility of design and operations are also maximized with dedicated processors.

Develop the delta FSSS for command/control functions. Although the computer-aided approach is slightly more costly than the hardwired approach the Orbiter AFD panel constraints (pallet-only Spacelab configuration) will not accommodate a completely hardwired concept. Development of computer-aided software and hardware on an individual experimenter basis would be costly and inefficient.

When feasible, implement the computer-aided command/control approach. The reflight nature of the ATL program indicates that even if experiments are initially scheduled for the habitable-module Spacelab configuration, they may be subsequently scheduled for a pallet-only flight. Because of the AFD panel constraints, a hardwired panel used in the habitable module may not be usable in the AFD. Thus, a second development would be required. Initial development of the computer-aided approach for command/control functions would provide the PI and Langley the maximum flexibility in payload grouping/flight scheduling. Also, the computer-aided approach is more adaptable to changes than the hardwired approach. With the evolving technology associated with ATL experiments, flexibility of design is extremely important.

GROUND OPERATIONS CONSIDERATIONS

Implement the GSSS. The consideration of the number of times that mission planning analyses must be performed and the duration of the ATL program make it almost imperative that a tutorial software *tool* be utilized. Batch processing is not only cumbersome and frustrating, it is also costly. In this study, only the payload integrator was considered in the mission planning phase. However,



each PI must also do individual mission planning analyses that pertain to his experiment. Current PI's may have the necessary software programs, but during the course of the ATL program it is doubtful if more than a small percentage of the PI's will be so equipped. Implementation of a tutorial GSSS approach will facilitate the participation of a broad segment of the scientific community and minimize the affect of personnel turnover in the payload integrator's organization.

Adopt the mini-disc mission analysis approach. Although the remote terminal approach will suffice the convenience, flexibility, and programmatic costs warrant the mini-disc approach. This dedicated processor approach becomes highly desirable when the PI's are considered. Again, if a broad segment of the scientific community is to participate in the ATL program, techniques to minimize the costs of the individual PI's and maximize the accessibility to data banks must be implemented. For example, providing a remote terminal link between a PI at the University of South Dakota and a central computer at Langley is unrealistic. Except for the disc-memory device this PI's dedicated processor would suffice. Disc-memory devices could be shared between PI's in the same manner as the proposed sharing of dedicated mini-processors. (Note: disc-memory devices for individual PI's were not included in the cost analyses of this study.)

DESIGN CONSIDERATIONS

As both the Spacelab hardware and Spacelab operations are in a design/development stage, specific design requirements for ATL payloads are not identifiable at this time. However, the following guidelines indicate the types of design requirements that will have to be met.

1. All potential hazards due to experiment operations or to credible failures of experiment equipment will be redundantly instrumented; these instrument signals, properly conditioned, will be direct-wired to the Spacelab and Orbiter caution/warning system. The PI will be required to demonstrate to a safety review board the adequacy of his analysis and design to avoid or contain any hazard or hazardous condition due to his equipment or its operation.
2. Experiment-derived data that will be telemetered to ground via the Orbiter avionics system will be acquired, formatted, and annotated within the experiment system prior to transmission under control of the Spacelab CDMS.
3. The PI shall provide the interface hardware within his equipment to decode and interpret command signals from the CDMS RAU.
4. The CDMS will provide Orbiter-derived annotation data (time, position, attitude) on a periodic basis, via the data bus/RAU network. The PI shall provide the interface hardware to accept and process these digital signals within his equipment.



- *5. The PI should consider a computer-aided implementation of command/control functions when the operator's procedures are complex and sensitive to proper sequencing.
- *6. The PI should consider a computer-aided implementation of command/control functions when the experiment is remotely located from the operator's work station (specifically for pallet-only missions).
- 7. The PI should consider an automated approach of implementing control for (a) emergency sequences, (b) time-critical operations, (c) repetitive sequences where the operator's judgment is not required, and (d) operator reaction time may be exceeded. (Note: *Automatic* control may utilize a mini/micro computer, but more generally would be implemented by clocked timer-sequencers or other mechanical devices--particularly (a) and (c)--or by sensor *trigger* mechanisms such as limit switches or optical detectors.)
- *8. The PI should consider a hardwired approach for implementing control if (a) the experiment equipment requires no in-flight mechanical or procedural adjustments, or (b) the operator's participation is limited to initiating/terminating automatic sequences.

*These guidelines should be considered in conjunction with Flight Operations Considerations--When feasible, implement the computer-aided command/control approach.



4.0 RELATED FUTURE EFFORT

It is recognized that the preferred approaches for ATL flight and ground operations software are contingent upon two key software development tools--the FSSS and the GSSS. Because of the repetitive nature of ATL Spacelab flights, as well as other Spacelab payloads, a significant programmatic cost savings can be achieved if software reuse is maximized. It is believed that the proposed/conceptually defined FSSS will facilitate the reuse of on-board software as well as expedite the preparation of mission-unique software. A more detailed definition and synthesis of the primary elements of the FSSS, coupled with a demonstration with representative payload equipment, should be accomplished before a Spacelab programmatic commitment is made. It is recommended that such an activity be initiated within this calendar year in order to support the initial Spacelab flights in a timely manner.

The additions to the basic FSSS for command/control by an interactive display terminal is also recommended. Pallet-only configurations are frequent. With the limited panel space for payloads in the Orbiter, experiment grouping flexibility will be constrained unless shared intelligent terminals are viable. It should be emphasized that unless the basic FSSS is provided, the computer-aided approach for command and control is not recommended. Without the FSSS tutorial feature, each PI/user would be forced to prepare this software using more conventional methods, or use the CDMS capability. Use of the CDMS would, of course, recentralize a major effort with an attendant increase in costs.

A conceptual CDMS-dedicated processor interface was defined. As both the Spacelab and ATL payloads are at the hardware development stage, a definitized interface (signal characteristics, coding, timing, etc.) should be established. This proposed effort consists basically of analyzing the specific characteristics of the CDMS and the Spacelab data bus and determining the interface requirements/specifications that a dedicated processor must meet. This analysis is not recommended until after the preliminary design review on the CDMS later this year.

The current GSSS development at MSFC was primarily for remote terminal applications. A detailed analysis of the MSFC programs is required to determine the potential extent of modifications to MSFC programs for use on dedicated mini-processors. As the MSFC program is still in progress, a preliminary activity to convert the programs to at least one mini-processor is underway, and a commitment to a local GSSS is not time-critical, this effort can be postponed for at least another year.