

# **INDEPENDENT ORBITER ASSESSMENT**

## **ASSESSMENT OF THE DATA PROCESSING SYSTEM FMEA/CIL**

**28 NOVEMBER 1986**

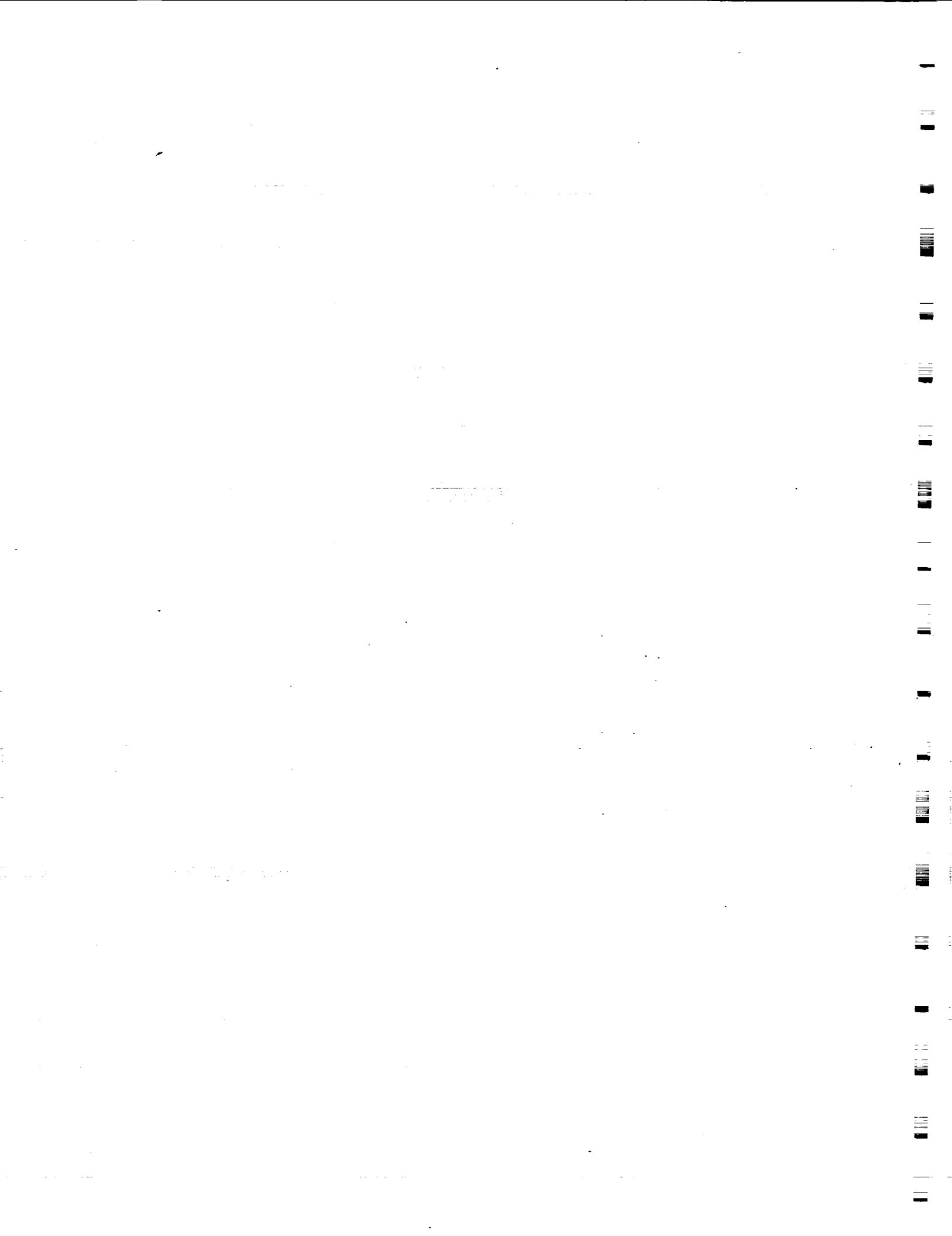

MCDONNELL DOUGLAS ASTRONAUTICS COMPANY  
HOUSTON DIVISION

SPACE TRANSPORTATION SYSTEM ENGINEERING AND OPERATIONS SUPPORT

WORKING PAPER NO. 1.0-WP-VA86001-08

INDEPENDENT ORBITER ASSESSMENT  
ASSESSMENT OF THE DATA PROCESSING SYSTEM FMEA/CIL

28 November 1986

This Working Paper is Submitted to NASA under  
Task Order No. VA86001, Contract NAS 9-17650

PREPARED BY: *H. J. Lowery*  
H J Lowery  
Lead Analyst  
Independent Orbiter  
Assessment

PREPARED BY: *W.A. Haufler*  
W.A. Haufler  
Lead Analyst  
Independent Orbiter  
Assessment

APPROVED BY: *B.J. Robb*  
B.J. Robb  
DPS Lead  
Independent Orbiter  
Assessment

APPROVED BY: *G.W. Knori*  
G.W. Knori  
Technical Manager  
Independent Orbiter  
Assessment

APPROVED BY: *W.F. Huning*  
W.F. Huning  
Deputy Program Manager  
STSEOS

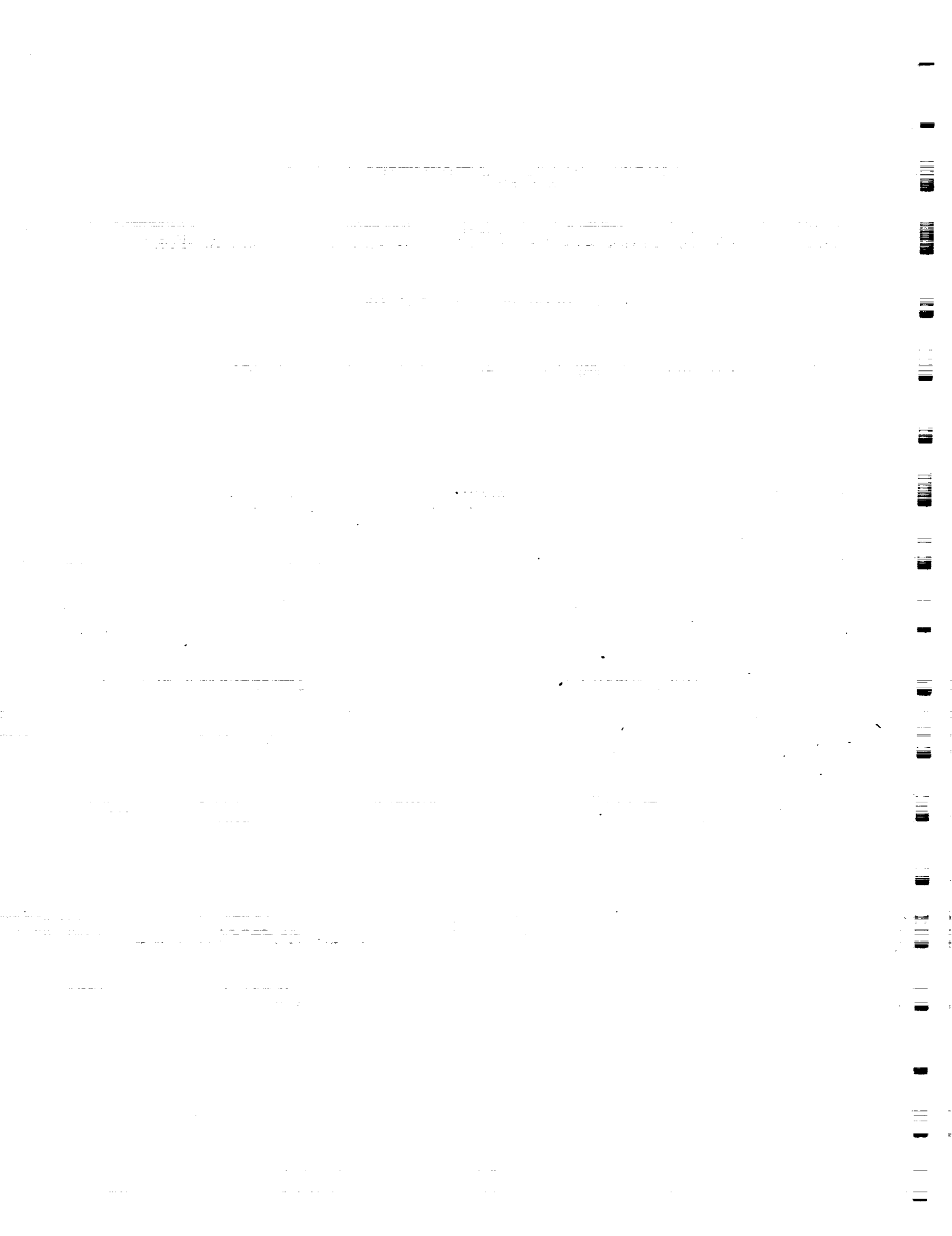



## CONTENTS

	Page
1.0 EXECUTIVE SUMMARY	1
2.0 INTRODUCTION	3
2.1 Purpose	3
2.2 Scope	3
2.3 Analysis Approach	3
2.4 Ground Rules and Assumptions	4
3.0 SUBSYSTEM DESCRIPTION	5
3.1 Design and Function	5
3.2 Interfaces and Locations	6
3.3 Hierarchy	6
4.0 ASSESSMENT RESULTS	17
4.1 Multiplexer/Demultiplexers (MDM)	20
4.2 General Purpose Computer (GPC)	23
4.3 Multifunction CRT Display System (MCDS)	25
4.4 Data Bus Coupler (DBC)	25
4.5 Data Bus Isolation Amplifier (DBIA)	25
4.6 Mass Memory Unit (MMU)	26
4.7 Engine Interface Unit (EIU)	27
5.0 REFERENCES	28
APPENDIX A ACRONYMS	A-1
APPENDIX B DEFINITIONS, GROUND RULES, AND ASSUMPTIONS	B-1
B.1 Definitions	B-2
B.2 Project Level Ground Rules and Assumptions	B-4
B.3 Subsystem Specific Ground Rules and Assumptions	B-6
APPENDIX C ASSESSMENT WORKSHEETS	C-1
APPENDIX D CRITICAL ITEMS	D-1
APPENDIX E ANALYSIS WORKSHEETS	E-1
APPENDIX F NASA FMEA TO IOA WORKSHEET CROSS REFERENCE / RECOMMENDATION	F-1

## List of Figures

	Page
Figure 1 - DPS FMEA/CIL ASSESSMENT	2
Figure 2 - DPS SUBSYSTEM OVERVIEW	7
Figure 3 - DPS MULTIPLEXER/DEMULTIPLEXER (MDM)	8
Figure 4 - DPS GPC CENTRAL PROCESSING UNIT (CPU)	9
Figure 5 - DPS GPC INPUT/OUTPUT PROCESSOR (IOP)	10
Figure 6 - DPS MCDS FUNCTIONAL BLOCK DIAGRAM	11
Figure 7 - DPS MCDS	12
Figure 8 - DPS DATA BUS COUPLERS	13
Figure 9 - DPS MASS MEMORY UNIT (MMU)	14
Figure 10 - DPS ENGINE INTERFACE UNIT (EIU)	15
Figure 11 - DPS FUNCTIONAL INTERFACES AND LOCATIONS	16

## List of Tables

	Page
Table I - SUMMARY OF IOA FMEA ASSESSMENT	17
Table II - SUMMARY OF IOA CIL ASSESSMENT	18
Table III- SUMMARY OF IOA RECOMMENDED FAILURE CRITICALITIES	18
Table IV - SUMMARY OF IOA RECOMMENDED CRITICAL ITEMS	19
Table V - IOA WORKSHEET NUMBERS	19

Independent Orbiter Assessment  
Assessment of the Data Processing System FMEA/CIL

1.0 EXECUTIVE SUMMARY

The McDonnell Douglas Astronautics Company (MDAC) was selected in June 1986 to perform an Independent Orbiter Assessment (IOA) of the Failure Modes and Effects Analysis (FMEA) and Critical Items List (CIL). Direction was given by the STS Orbiter and GFE Projects Office to perform the hardware analysis using the instructions and ground rules defined in NSTS 22206, Instructions for Preparation of FMEA and CIL, 10 October 1986.

The IOA effort first completed an analysis of the Data Processing System (DPS) hardware, generating draft failure modes and potential critical items. To preserve independence, this analysis was accomplished without reliance upon the results contained within the NASA FMEA/CIL documentation. The IOA results were then compared to the NASA FMEA/CIL baseline with proposed Post 51-L updates included. A resolution of each discrepancy from the comparison is provided through additional analysis as required. This report documents the results of that comparison for the Orbiter DPS hardware.

The IOA product for the DPS analysis consisted of one hundred twenty-two failure mode "worksheets" that resulted in twenty-three potential critical items being identified. Comparison was made to the NASA baseline (as of 19 November 1986) which consisted of seventy-eight FMEAs and twenty-five CIL items. The comparison determined if there were any results which had been found by the IOA but were not in the NASA baseline. This comparison produced agreement on all but four FMEAs which caused differences in two CIL items. Figure 1 presents a comparison of the proposed Post 51-L NASA baseline, with the IOA recommended baseline, and any issues.

The issues arose due to differences between the NASA and IOA FMEA/CIL preparation instructions. NASA had used an older ground rules document which has since been superseded by the NSTS 22206 used by the IOA. After comparison, there were no discrepancies found that were not already identified by NASA, and the remaining issues may be attributed to differences in ground rules.

# DPS FMEA/CIL ASSESSMENT OVERVIEW

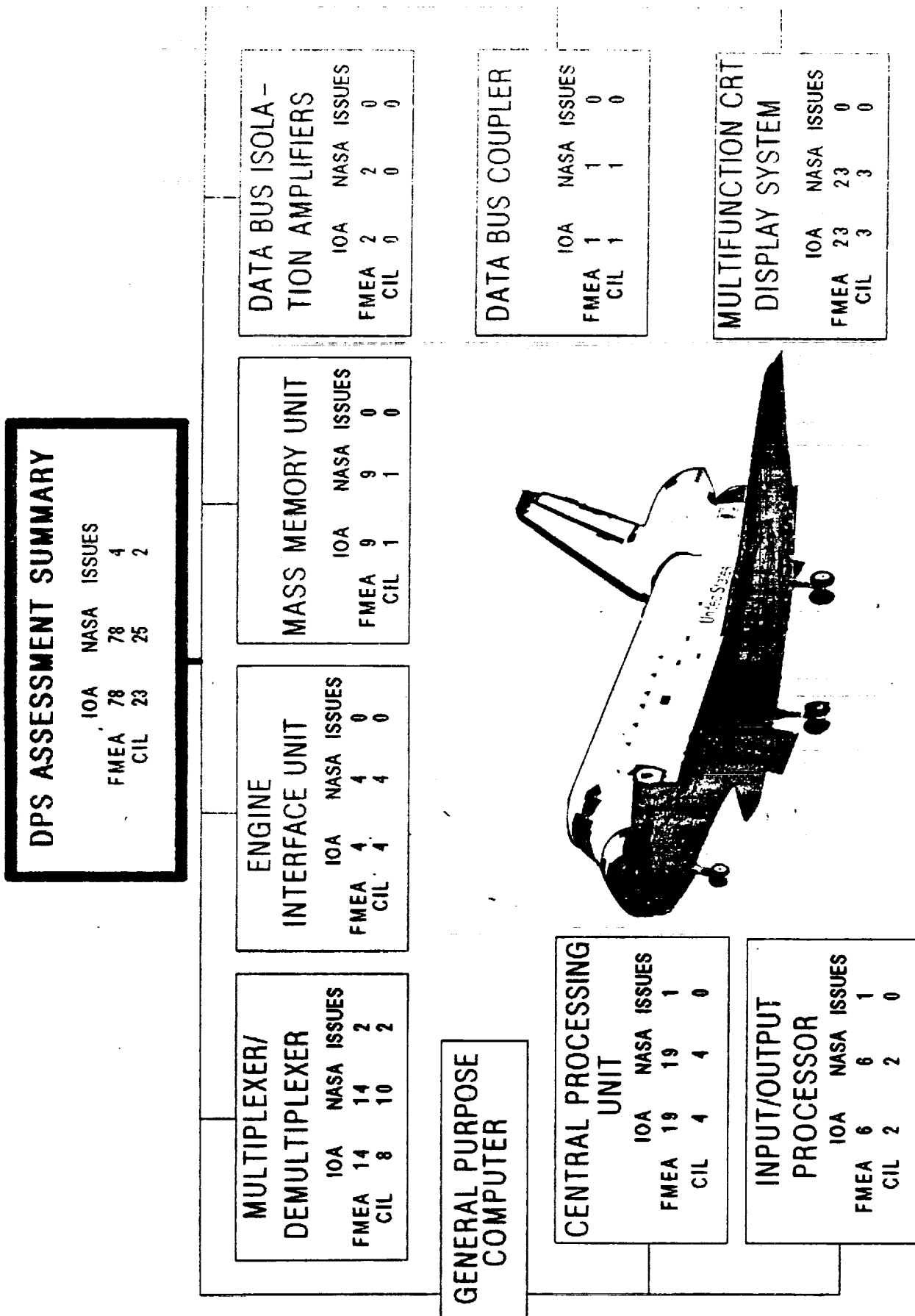

COUNT CORRECT AS OF 11/19/86

Figure 1 - DPS FMEA/CIL ASSESSMENT

## 2.0 INTRODUCTION

### 2.1 Purpose

The 51-L Challenger accident prompted the NASA to readdress safety policies, concepts, and rationale being used in the National Space Transportation System (NSTS). The NSTS Office has undertaken the task of reevaluating the FMEA/CIL for the Space Shuttle design. The MDAC is providing an independent assessment of the proposed Post 51-L Orbiter FMEA/CIL for completeness and technical accuracy.

### 2.2 Scope

The scope of the independent FMEA/CIL assessment activity encompasses those Shuttle Orbiter subsystems and GFE hardware identified in the Space Shuttle Independent FMEA/CIL Assessment Contractor Statement of Work. Each subsystem analysis addresses hardware, functions, internal and external interfaces, and operational requirements for all mission phases.

### 2.3 Analysis Approach

The independent analysis approach is a top-down analysis utilizing as-built drawings to breakdown the respective subsystem into components and low-level hardware items. Each hardware item is evaluated for failure mode, effects, and criticality. These data are documented in the respective subsystem analysis report, and are used to assess the proposed Post 51-L NASA and Prime Contractor FMEA/CIL. The IOA analysis approach is summarized in the following Steps 1.0 through 3.0. Step 4.0 summarizes the assessment of the NASA and Prime Contractor FMEA/CIL which is documented in this report.

#### Step 1.0 Subsystem Familiarization

- 1.1 Define subsystem functions
- 1.2 Define subsystem components
- 1.3 Define subsystem specific ground rules and assumptions

#### Step 2.0 Define subsystem analysis diagram

- 2.1 Define subsystem
- 2.2 Define major assemblies
- 2.3 Develop detailed subsystem representations

#### Step 3.0 Failure events definition

- 3.1 Construct matrix of failure modes
- 3.2 Document IOA analysis results

Step 4.0 Compare IOA analysis data to NASA FMEA/CIL

- 4.1 Resolve differences
- 4.2 Review in-house
- 4.3 Document assessment issues
- 4.4 Forward findings to Project Manager

2.4 Ground Rules and Assumptions

The ground rules and assumptions used in the IOA are defined in Appendix B. The subsystem specific ground rules were defined to limit the analysis to single-failed-parts for each failure mode. A subset of the failure mode keywords were identified for the DPS team. This allowed for commonality in the analysis results.

### 3.0 SUBSYSTEM DESCRIPTION

#### 3.1 Design and Function

The DPS consists of that hardware required for data acquisition, data manipulation, data display, and data transfer on the Orbiter, and includes the five onboard computers and their interfaces. Reference Figure 2. More specifically, the DPS consists of the following components:

1. Twelve MDM units which convert and format data at the remote locations. Each MDM has internal redundancy and consists of a Multiplexer Interface Adapter (MIA), Sequential Control Unit (SCU), Input/Output Module, Analog To Digital Converter, and Power Supply. They convert and format serial digital GPC commands into parallel discrete, digital, and analog data for transfer to vehicle subsystem hardware. They also convert and format parallel discrete, digital, and analog data from vehicle subsystems into serial digital data for transmission to the GPCs. Reference Figure 3.
2. Five GPCs each consisting of a Central Processing Unit (CPU) and Input/Output Processor (IOP). The CPU functionally consists of an Arithmetic Logic Unit, Local Store, Master Bus Control Unit, Data Flow Multiplexer, Micro-code control unit, CPU Timer, Interrupt Logic, Main Memory Timing Page, Timers, Address Bus Control, Main Memory, and Power Supply. The IOP contains Control Monitor, IOP Main Memory, Channel Control, Direct Memory Access Queue, Arithmetic Logic Units, Local Store, Micro-code store and Decode, MIAs, and Time-slice and Multiplexing. One of the functions of the GPCs is to support guidance, navigation, and control requirements of the vehicle. They provide for the monitoring and control of vehicle subsystems. They also check for data transmission errors and crew input error. Vehicle system failures and out-of-tolerance conditions are annunciated by the GPCs. Reference Figure 4 and Figure 5.
3. The MCDS consists of three Keyboard Units (KU), four Display Units (DU) and four Display Electronics Units (DEU). Each KU has Keys, Switches and Lights. The DU consists of X/Y Deflection Amplifiers, Video Amplifiers, Cathode-Ray Tube, BITE and Power Supplies. The DEU has an Oscillator, Memory, Key-board Adapter, Symbol Generator, MIA, Control Logic, BITE, Load Switch, and Power Supplies. The subsystem provides for crew/vehicle interface via a keyboard and CRT display. The crew can interact with the subsystems with keyboard entries and executions. Reference Figure 6 and Figure 7.

4. Thirty serial digital data buses are connected to the Bus Terminal Units (BTUs) via 227 DBCs. The DBCs are shown in Figure 8.
5. Two DBIAs provide the amplification necessary to drive the stubs and provide isolation when the stubs are opened or shorted at the umbilicals.
6. Two MMUs contain MIAs, Read Electronics, Write Electronics, Mass Memory Control Logic, Power Supply with Switch, Tape Transport Mechanism with motor, tape and heads. The mass memory unit stores programs for loading into the GPCs and the MCDS. Reference Figure 9.
7. Three EIUs provide status and command capability of the main engines. Each EIU contains a MIA, BITE, Status Buffer, Controller Interface Adapter, Operational Interface Element, Data Status and Power Supply. The EIU transfers main engine control commands from the GPC and main engine status for use by the GPC, the GSE launch processing system, and the operational instrumentation system. Reference Figure 10.

The DPS interfaces with many onboard Orbiter systems including the Main Propulsion System, Solid Rocket Boosters, Reaction Control System (RCS), Orbital Maneuvering System (OMS), Air Surface Controls used for guidance and control, Nose-wheel Steering, and the Master Timing Unit.

### 3.2 Interfaces and Locations

The DPS hardware is located throughout the Orbiter. The composite data bus network provides the hardware interfaces between the GPCs and all other avionics subsystems that communicate via a digital data format. Reference Figure 11. GPCs 1 and 4 are located in Avionics Bay 1 while GPCs 2 and 5 are located in Avionics Bay 2, to provide separation of redundancy. GPC 3 is located in Avionics Bay 3. Each GPC interfaces to all Flight Critical MDMS, however only one GPC normally communicates to only one FF and one FA MDM during ascent and entry dynamic flight.

### 3.3 Hierarchy

Figure 2 illustrates the hierarchy of the DPS hardware and the corresponding subcomponents. Figures 3 through 10 comprise the detailed system representations.



# DATA PROCESSING SUBSYSTEM OVERVIEW

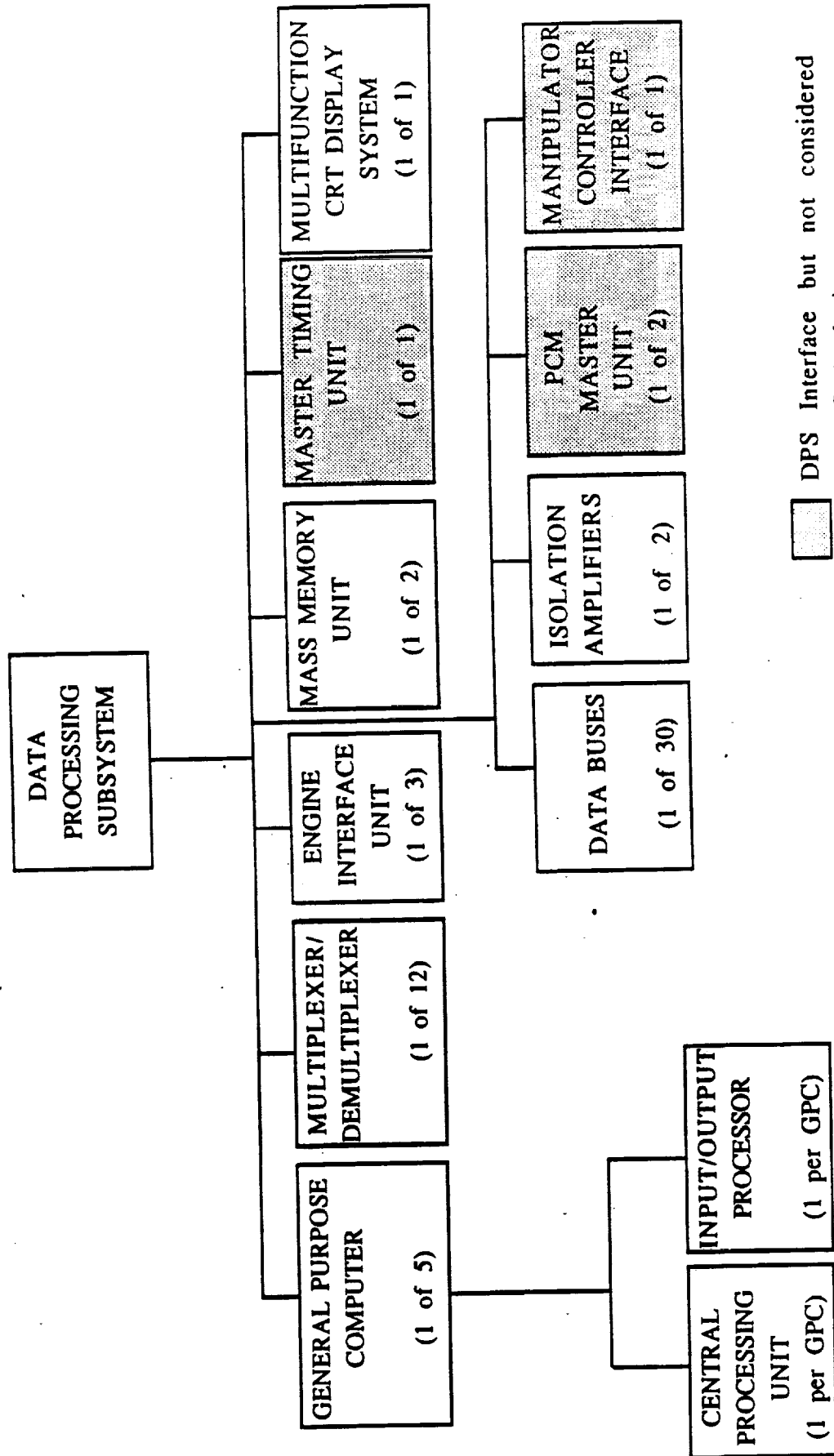

DPS Interface but not considered in DPS Analysis

Figure 2 - DPS SUBSYSTEM OVERVIEW

# DPS MULTIPLEXER/DEMULTIPLEXER

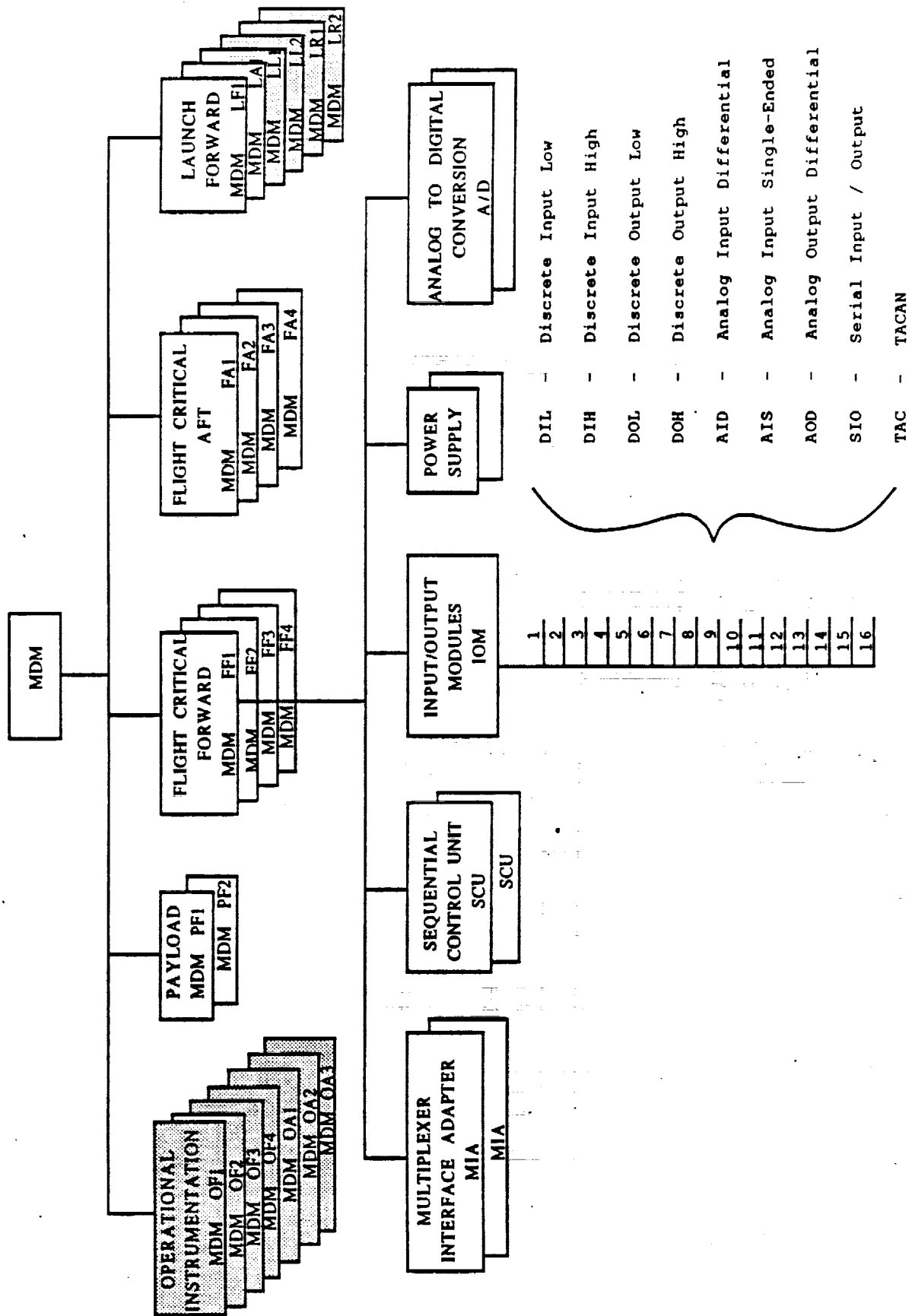

Figure 3 - DPS MULTIPLEXER/DEMULTIPLEXER (MDM)

# DPS GPC - CENTRAL PROCESSING UNIT

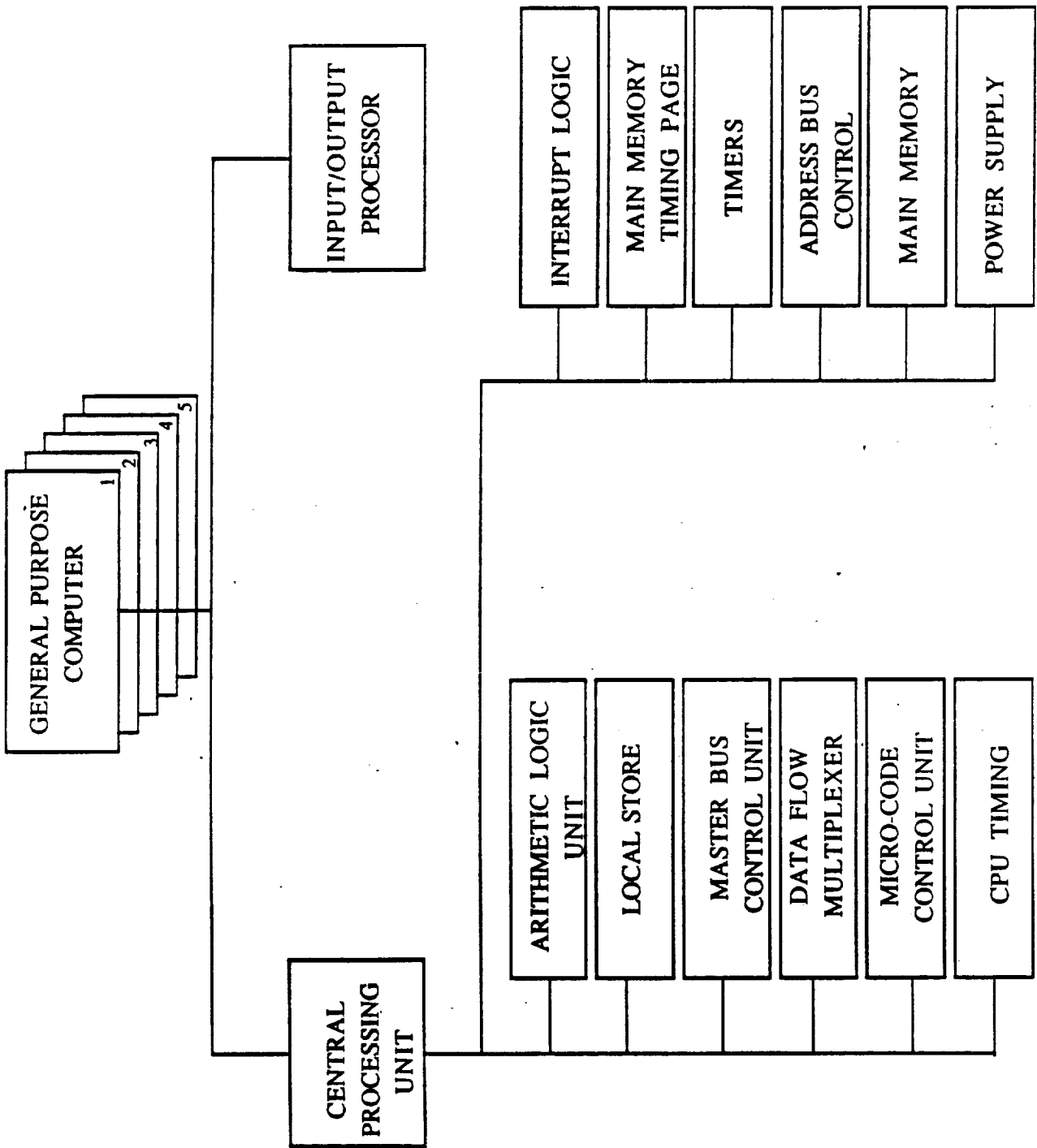

Figure 4 - DPS GPC CENTRAL PROCESSING UNIT (CPU)

# DPS GPC - INPUT/OUTPUT PROCESSOR

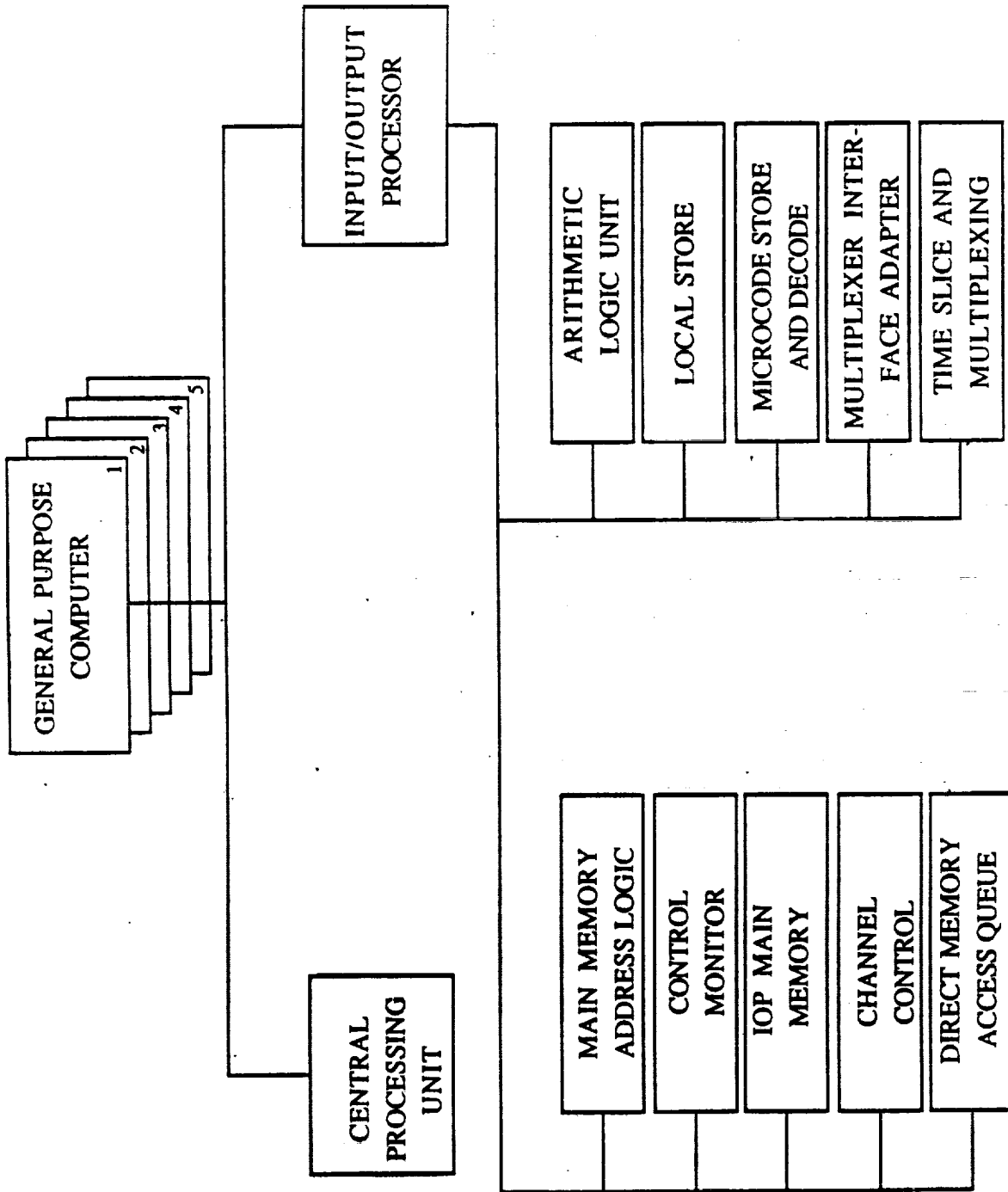

Figure 5 - DPS GPC INPUT/OUTPUT PROCESSOR (IOP)

# DPS MCDS FUNCTIONAL BLOCK DIAGRAM

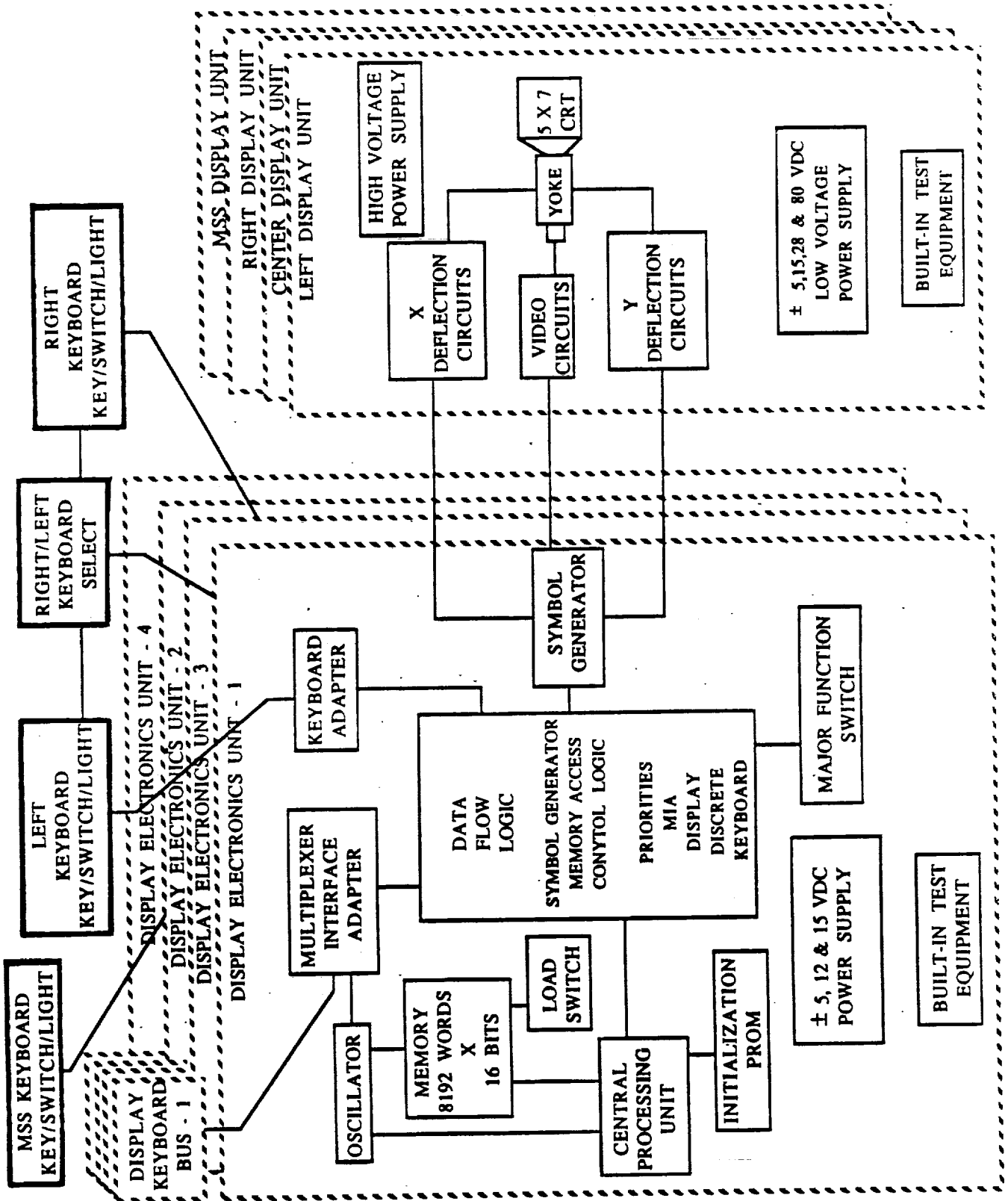

Figure 6 - DPS MCDS FUNCTIONAL BLOCK DIAGRAM

# DPS MCDS

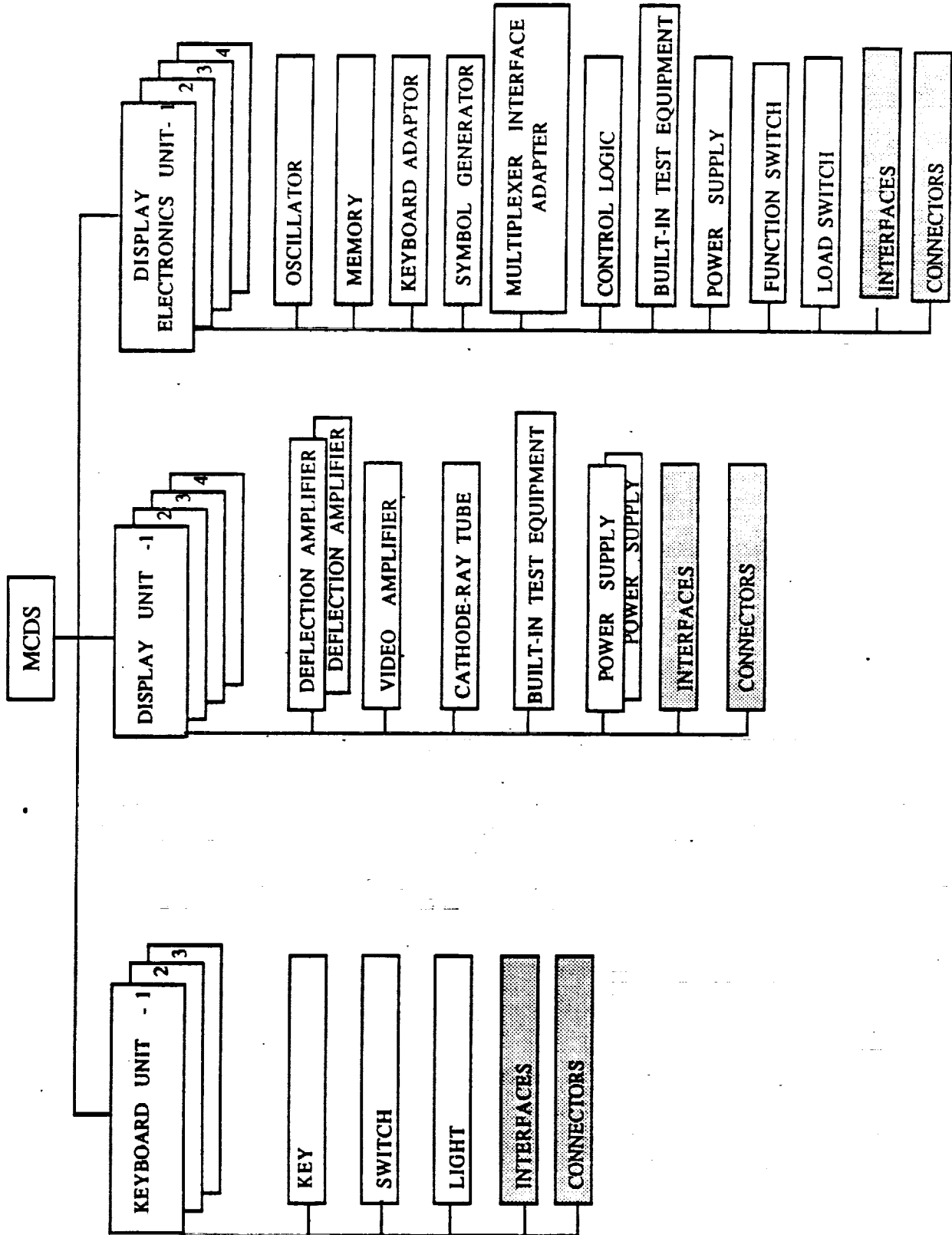
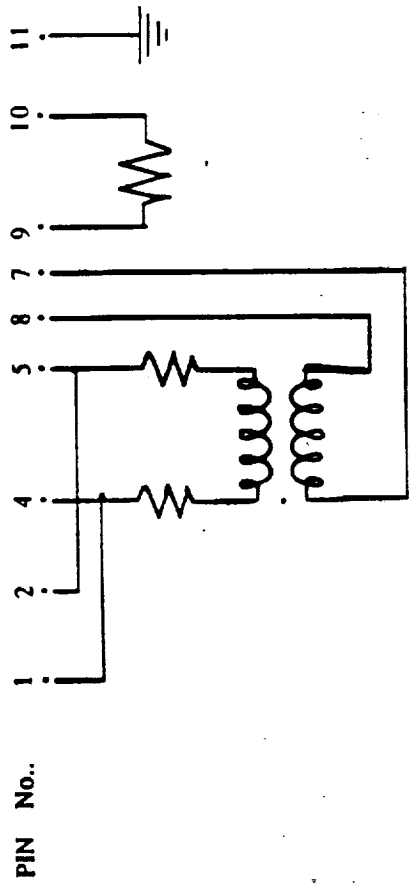

Figure 7 - DPS MCDS

# DPS DATA BUS COUPLERS



PIN No..	DATA BUS	QUANTITY	DATA BUS	QUANTITY
1	DISPLAY/KEYBOARD-1	6	INTER-COMPUTER-4	5
2	DISPLAY/KEYBOARD-2	7	INTER-COMPUTER-5	5
3	DISPLAY/KEYBOARD-3	6	INSTRUMENTATION/PCMMU-1	3
4	DISPLAY/KEYBOARD-4	7	INSTRUMENTATION/PCMMU-2	3
5	FLIGHT CRITICAL-1	11	INSTRUMENTATION/PCMMU-3	3
6	FLIGHT CRITICAL-2	11	INSTRUMENTATION/PCMMU-4	3
7	FLIGHT CRITICAL-3	11	INSTRUMENTATION/PCMMU-5	3
8	FLIGHT CRITICAL-4	11	LAUNCH/BOOST-1	16
9	FLIGHT CRITICAL-5	12	LAUNCH/BOOST-2	16
10	FLIGHT CRITICAL-6	12	MASS MEMORY-1	6
11	FLIGHT CRITICAL-7	12	MASS MEMORY-2	6
	FLIGHT CRITICAL-8	12	PAYLOAD INTERFACE-1	4
	INTER-COMPUTER-1	5	PAYLOAD INTERFACE-2	4
	INTER-COMPUTER-2	5	PAYLOAD-1	9
	INTER-COMPUTER-3	5	PAYLOAD-2	8

Figure 8 - DPS DATA BUS COUPLERS (DBC)

# DPS MASS MEMORY UNIT

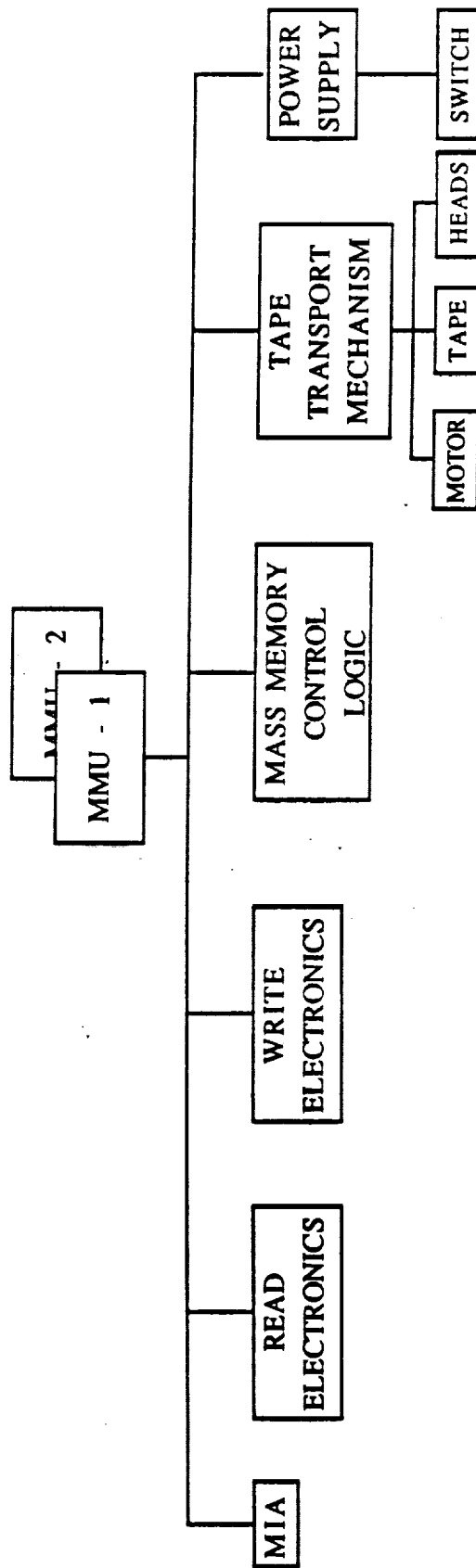

Figure 9 - DPS MASS MEMORY UNIT (MMU)



# DPS ENGINE INTERFACE UNIT

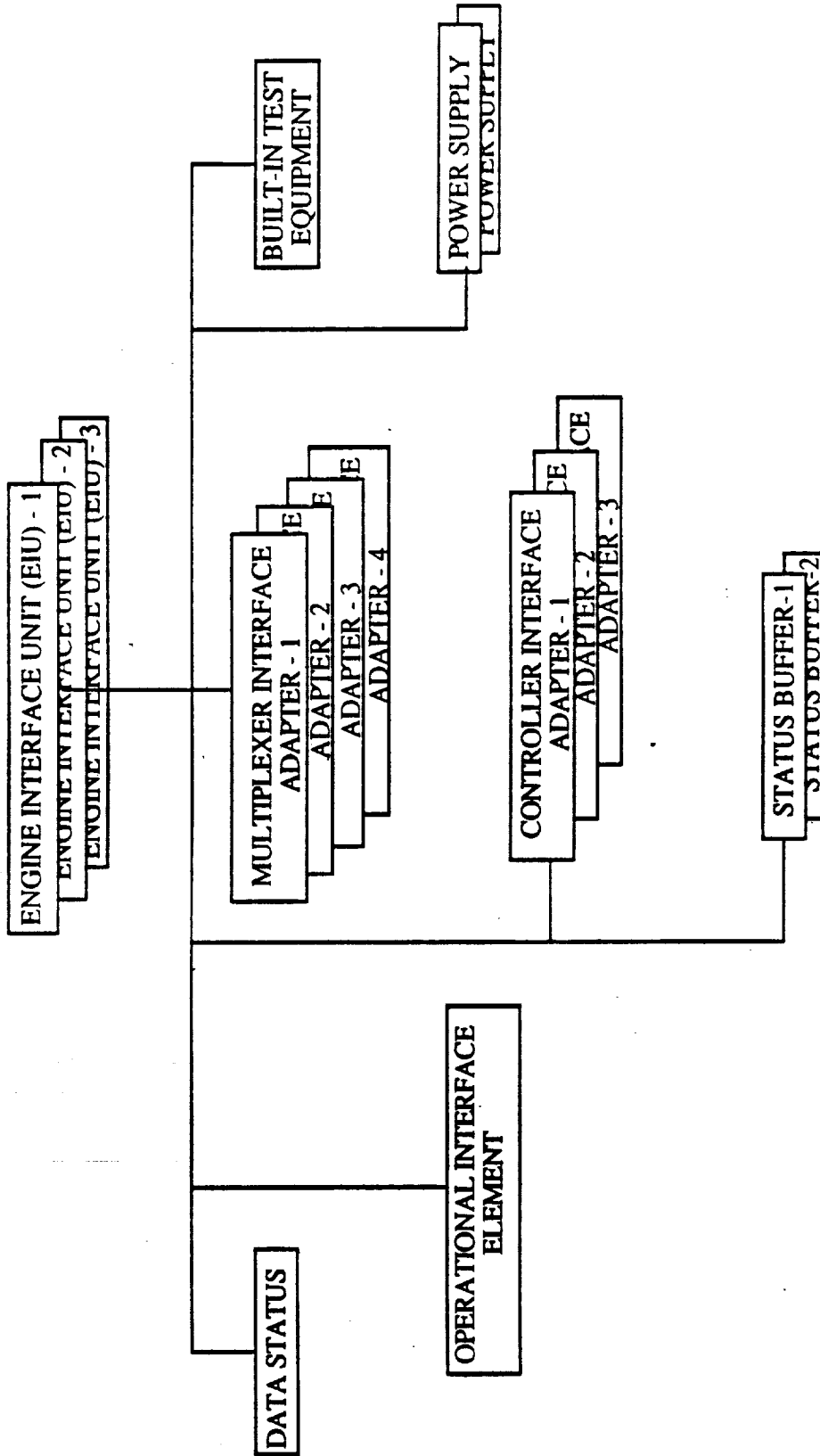

Figure 10 - DPS ENGINE INTERFACE UNIT (EIU)

# DATA PROCESSING SUBSYSTEM

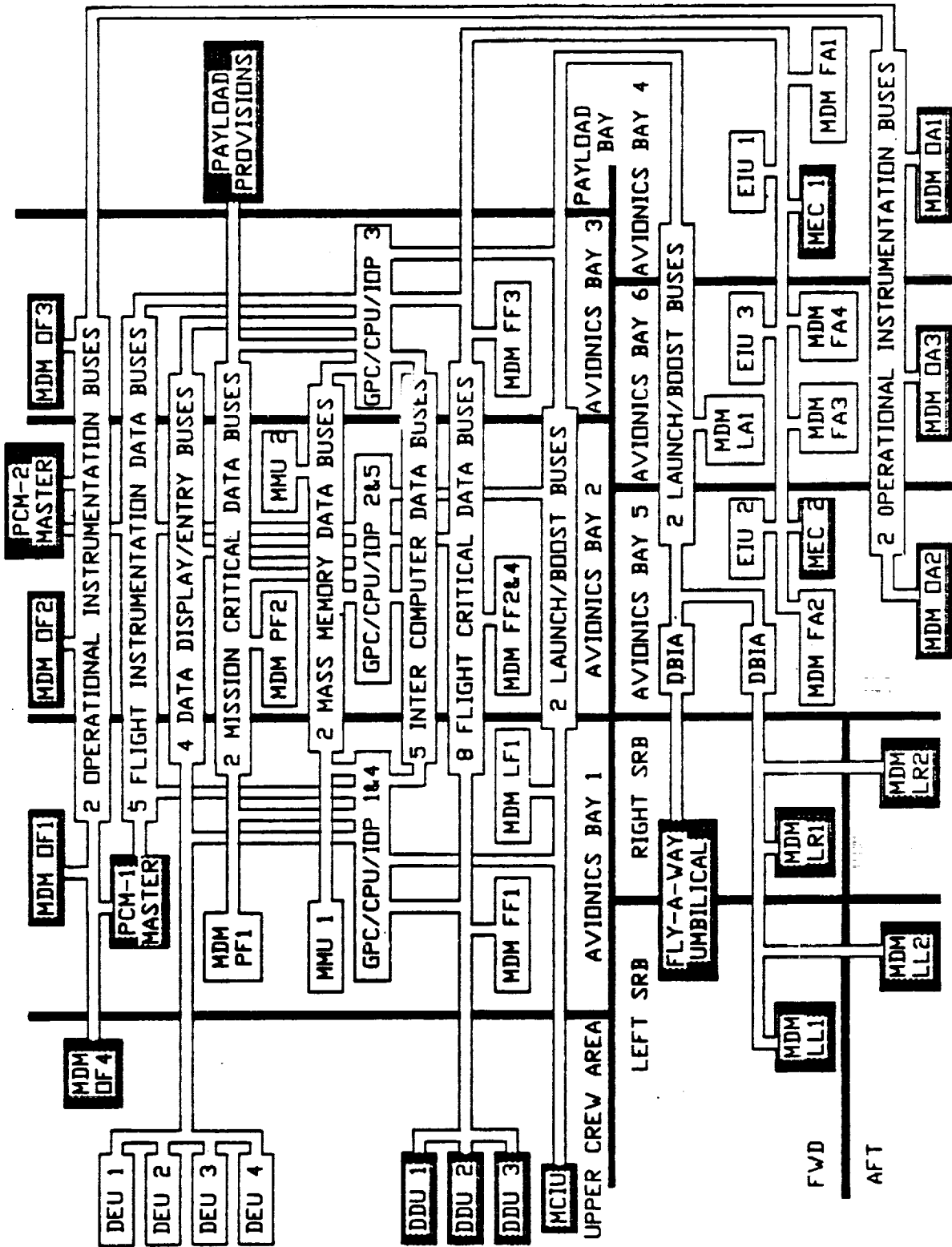

Figure 11 - DPS FUNCTIONAL INTERFACES AND LOCATIONS

#### 4.0 ASSESSMENT RESULTS

The IOA analysis of the DPS hardware initially generated eighty-five failure mode worksheets and identified two Potential Critical Items (PCIs) before starting the assessment process. In order to facilitate comparison, thirty-seven additional failure mode analysis worksheets were generated. These analysis results were compared to the proposed NASA Post 51-L baseline of seventy-eight FMEAs and twenty-five CIL items, which was generated using the Rockwell 100-2G FMEA/CIL instructions. Upon completion of the assessment, sixty of the seventy-eight FMEAs were in agreement. Of the eighteen that remained, fourteen had minor discrepancies that did not affect criticality. Of the remaining four, two issues were with FMEAs (05-5-B03-1-1 and 05-5-B03-2-1) that had considered failure modes outside the DPS subsystem, and caused inflated criticalities. These criticalities mistakenly placed both FMEAs on the CIL. The other two issues were with FMEAs (05-5-B01-1-1 and 05-5-B02-1-1) that also considered failure modes outside the DPS subsystem. However, when the correct failure mode is included, the current criticalities will remain unchanged. In summary, all issues may be attributed to differences between ground rules in Rockwell 100-2G and NSTS 22206 instructions. The IOA recommends correcting the failure modes considered in the four FMEAs, which lowers criticality assignments in two of the FMEAs, and removes them from the CIL.

A summary of the quantity of NASA FMEAs assessed, versus the recommended IOA baseline, and any issues identified is presented in Table I.

Table I Summary of IOA FMEA Assessment			
Component	NASA	IOA	Issues
MDM	14	14	2
GPC	25	25	2
MCDS	23	23	-
DBC	1	1	-
DBIA	2	2	-
MMU	9	9	-
EIU	4	4	-
TOTAL	78	78	4

A summary of the quantity of NASA CIL items assessed, versus the recommended IOA baseline, and any issues identified is presented in Table II.

Table II Summary of IOA CIL Assessment			
Component	NASA	IOA	Issues
MDM	10	8	2
GPC	6	6	-
MCDS	3	3	-
DBC	1	1	-
DBIA	-	-	-
MMU	1	1	-
EIU	4	4	-
<b>TOTAL</b>	<b>25</b>	<b>23</b>	<b>2</b>

Appendix C presents the detailed assessment worksheets for each failure mode identified and assessed. Appendix D highlights the NASA Critical Items and corresponding IOA worksheet ID. Appendix E contains the IOA analysis worksheets that were used to assess the NASA FMEA/CIL. Appendix F provides a cross reference between the NASA FMEA and corresponding IOA worksheet(s). IOA recommendations are also summarized.

Table III presents a summary of the IOA recommended failure criticalities for the Post 51-L FMEA baseline. Further discussion of each of these subdivisions and the applicable failure modes is provided in subsequent paragraphs.

TABLE III Summary of IOA Recommended Failure Criticalities							
Criticality:	1/1	2/1R	2/2	3/1R	3/2R	3/3	TOTAL
MDM	-	4	-	6	2	2	14
GPC	-	5	-	9	1	10	25
MCDS	-	3	-	14	1	5	23
DBC	-	1	-	-	-	-	1
DBIA	-	-	-	-	1	1	2
MMU	-	-	1	-	6	2	9
EIU	2	2	-	-	-	-	4
<b>TOTAL</b>	<b>2</b>	<b>15</b>	<b>1</b>	<b>29</b>	<b>11</b>	<b>20</b>	<b>78</b>

Of the failure modes analyzed, twenty-three were determined to be critical items. A summary of the IOA recommended critical items is presented in Table IV.

TABLE IV Summary of IOA Recommended Critical Items							
Criticality:	1/1	2/1R	2/2	3/1R	3/2R	3/3	TOTAL
MDM	-	4	-	4	-	-	8
GPC	-	5	-	1	-	-	6
MCDS	-	3	-	-	-	-	3
DBC	-	1	-	-	-	-	1
DBIA	-	-	-	-	-	-	-
MMU	-	-	1	-	-	-	1
EIU	2	2	-	-	-	-	4
TOTAL	2	15	1	5	-	-	23

The scheme for assigning IOA assessment (Appendix C) and analysis (Appendix E) worksheet numbers is shown in Table V.

Table V IOA Worksheet Numbers	
Component	IOA ID Number
MDM	DPS-100 to DPS-195
GPC	DPS-201 to DPS-232
MCDS	DPS-300 to DPS-321 (includes DBC and DBIA)
MMU	DPS-400 to DPS-417
EIU	DPS-501 to DPS-509

#### 4.1 Assessment Results MDM

The IOA has a total of forty-two assessment worksheets associated with the fourteen NASA MDM FMEAs; excluding the OF, OA, LL, and LR MDM groups, as shown in Figure 3. The IOA worksheets correspond to nine different failure modes for each of the four groups of MDMs, plus six worksheets that are power related. The numbering scheme is shown in the table below.

<u>IOA ID Range</u>	<u>Item Group</u>
DPS-100 to 108	FF - Flight Forward
DPS-120 to 128	FA - Flight Aft
DPS-140 to 148	PF - Payload Forward
DPS-180 to 188	LF,LA - Launch Forward and Aft
DPS-190 to 195	Power related: RPCs, switches, and resistors

Three basic failure modes were found: Loss of Output, Erroneous Output, and Premature Operation. A failure mode may have a different effect, and thus a different criticality, if applied separately to both output sides of a MDM; that is, a MDM's outputs to GPCs and LRUs (such as sensors and effectors). Thus it was decided to treat each output side separately for each basic failure mode, resulting in six failure modes; such as "Loss of Output to GPC" and "Loss of Output to LRU". As it turned out, the effects were somewhat different but the criticalities remained the same.

Three other failure modes were added which were considered applicable to only one output. These are "Selected All Channels Wrong to LRU" (worksheets DPS-106, 126, 146, and 186), "Stuck on a Constant Output to LRU" (DPS-107, 127, 147, and 187), and "Falsely Stuck on Busy Mode" to GPC (DPS-108, 128, 148, and 188). The first two specific failure modes could be considered special cases of "Erroneous Output to LRU", and the third failure mode could be considered a special case of "Loss of Output to GPC". They were considered on the possibility that the specific cases would differ in effects and criticality from the general cases. Again, the result was that these specific cases differed in their effects but not in their criticalities from the general cases.

The NASA FMEAs considered general failure modes, consequently each output and specific cases were not covered uniquely. This resulted in one (NASA FMEA) to many (IOA worksheets) relationships, as shown in the following table. This table shows how the NASA FMEAs and IOA worksheets associated with MDMs map onto each other.

Failure Mode	Item	NASA FMEAs	IOA Assessment Worksheets (Appendix. C)
Loss of Output	FF	05-5-B03-2-1	100, 101, 108
	FA	05-5-B03-1-1	120, 121, 128
	PF	05-5-B03-5-1	140, 141, 148
	LF,LA	05-5-B03-4-1	180, 181, 188
Erroneous Output	FF	05-5-B03-2-2	102, 103, 106, 107
	FA	05-5-B03-1-2	122, 123, 126, 127
	PF	05-5-B03-5-2	142, 143, 146, 147
	LF,LA	05-5-B03-4-2	182, 183, 186, 187
Premature Output	FF	no map	104, 105
	FA	no map	124, 125
	PF	no map	144, 145
	LF,LA	no map	184, 185
Miscellaneous	Resistor	05-6S-BRES3-1	190
	RPC	05-6S-BRPC3-1	191
	RPC	05-6S-BRPC3-2	192
	Switch	05-6S-BSW3 -1	193
	Switch	05-6S-BSW3 -2	194
	Switch	05-6S-BSW5 -3	195

The number of FMEAs and CILs by criticality are summarized in the following table. The Unmapped IOA column is the raw number of IOA analysis worksheets. The Mapped IOA column is the number of IOA analysis worksheets after they have been mapped onto the NASA FMEAs.

Criticality	Unmapped Mapped		NASA	IOA CILs	Issues
	IOA	IOA			
2/1R	15	4	6	4	2
2/2	0	0	0	0	0
3/1R	16	6	4	4	0
3/2R	9	2	2	0	0
3/3	2	2	2	0	0
Total	42	14	14	8	2

The NASA FMEAs also covered power related items associated with the MDMs, including Remote Power Controllers (RPCs), Power Switches, and Current Limiting Resistors. IOA did not cover these items in the original analysis due to time constraints, but did cover them later, concurring with NASA's reevaluation of these six. IOA's DPS subsystem team did not cover the Operational Instrumentation Forward and Aft (OA and OF) MDMs, since they were considered to be in the domain of IOA's Instrumentation subsystem team. IOA and NASA also did not cover the Launch Left and Launch Right (LL and LR) MDMs since they are within the SRBs.

The difference in the number of FMEAs is due to the fact that IOA considered more specific failure modes than NASA. Another difference is that NASA did not consider the "Premature Operation to GPC" and "Premature Operation to LRU" failure modes for MDMS. This however is not an issue since the criticality of the function of the hardware item (2/1R) was not increased by these failure modes. Also, after further analysis these failure modes are considered to be non-credible.

The criticalities for the LF and LA MDMS (3/2R) were the same for IOA and NASA. For the FF, FA, and PF MDMS however, IOA's criticalities (3/1R) were lower than NASA's criticalities (2/1R). Part of this difference is due to whether the effects of multiple unrelated failures were taken into account. The NASA, using the Rockwell 100-2G hardware criticality 2 ground rules, considered in FMEAs 05-5-B03-1-1 and 05-5-B03-2-1, a MDM failure and then considered an Aero Surface Amplifier (ASA) next related failure outside the DPS subsystem. Whereas, the IOA, using NSTS 22206, considered in assessment worksheets DPS-100, DPS-101, DPS-108, DPS-120, DPS-121, and DPS-128, a MDM failure and then considered the next redundant item failure to be another MDM. The IOA does not concur with these two NASA reevaluations. The IOA believes the hardware criticality should be downgraded to three, thereby removing these two FMEAs from the CIL. The IOA concurred with the remaining twelve FMEAs.



#### 4.2 Assessment Results GPC

The GPC analysis was subdivided into IOP and CPU failures. Generic black box failures were analyzed with causes stemming from failures of the subcomponents such as the MIA, as shown in Figure 4 and Figure 5. IOA has analyzed twenty-five failure modes (FMEAs) related to the General Purpose Computers (GPCs). Four of these FMEAs are attributable to the Input/Output Processors (IOP), eleven are related to the Central Processing Units (CPU), and the remaining ten affect various EPD&C switch functions associated with the GPC. NASA wrote twenty-five GPC related FMEAs: two CPU related, two IOP related, five switch related, four GPC status related, and two GPC power related. The following table is a summary of the GPC related FMEA criticalities including the results of the DPS Pre-board:

<u>Criticality</u>	<u>IOA</u>	<u>NASA</u>	<u>IOA CILs</u>	<u>Issues</u>
2/1R	5	5	5	2
3/1R	9	9	1	0
3/2R	1	1	0	0
3/3	10	10	0	0
Total	25	25	6	2

The seven NASA proposed individual power component failures (FMEA 05-6S-BDIOx-1, 05-6S-BDMC1-1, 05-6S-BDMC1-2, 05-6S-BFWS1-1, 05-6S-BRES1-1, 05-6S-BRPC1-1, and 05-6S-BRPC1-2) were analyzed, along with the four failures of the GPC status indicators. These failure modes are covered in Appendix E.

Of the five switch related failures analyzed by NASA, the CPU Output Switch FMEAs (05-5-B15-1-1 and 05-5-B15-1-3) agree with the IOA assessment (DPS-211) as does the Mode Switch FMEA (05-5-B17-1-1, DPS-210). One GPC Power Switch FMEA (05-6S-BSW1-2) written by NASA is confirmed by a similar IOA FMEA (DPS-216) as criticality 3/1R; the newly-proposed GPC Power Switch FMEA (05-6S-BSW1-3) is consistent with the IOA analysis DPS-217. IOA agrees with the assessment that inadvertent power switch opening has the same effects as CPU Loss of Output (05-5-B01-1-1).

The NASA and IOA analyses of the CPU and IOP erroneous output FMEAs (05-5-B01-1-2, 05-5-B02-1-2, DPS-206 and DPS-202, respectively) are identical in criticality 3/1R, as are the analyses of the inadvertent command outputs from the IOP with criticality 2/1R (05-5-B02-1-3, DPS-225). An IOA analysis of erroneous data inputs to the IOP (DPS-204) brought similar effects with 3/1R criticality.

The IOA analyzed a failure mode (DPS-208) on the CPU which was not considered by NASA. This 2/1R failure is similar in effect to the IOP inadvertent command output failure (05-5-B02-1-3): CPU attempts to output data on incorrect bus due to errors in memory locations containing configuration or bus-stringing parameters (e.g. the Nominal Bus Assignment Table). In this case two output data channels would be lost simultaneously and the actuators would not be able to select the correct data paths. IOA determined this to be a non-credible failure mode during the assessment process.

The NASA analysis of the CPU "Loss Of Output" (05-5-B01-1-1) has a criticality of 2/1R. IOA analysis 205, using the NSTS 22206 does not take into account the effects of multiple unlike failures outside the DPS subsystem. IOA does not agree with the effects assigned by NASA. The IOA recommends changing the effects to delete the sentence "During ascent/entry, this...". The IOA does concur with the rest of NASA's reevaluation and rationale.

The NASA analysis of the IOP "Loss of Output" (05-5-B02-1-1) has a criticality of 2/1R. Initially, the IOA analysis 201 assigned a hardware criticality of 3 for this failure mode. The IOA does not believe a single IOP failure would cause loss of mission. The second failure of an IOP would not result in loss of crew/vehicle. However, NASA's failure effects coupled this failure with an undetected ASA failure (outside the DPS subsystem). This could result in two healthy paths being voted out. This could possibly cause loss of vehicle. Simultaneous dissimilar failures were excluded from the IOA. Multiple failures are inconsistent with the NSTS 22206. The IOA recommends changing the effects to delete the sentence "During ascent/entry, this...". The IOA does concur with the rest of NASA's reevaluation and rationale.

#### 4.3 Assessment Results MCDS

The MCDS consists of the KU, DU, and DEU. Functional failures of components were analyzed. These components are shown functionally in Figure 6 and Figure 7. Nine failure modes were identified, thirty IOA assessment worksheets and twenty-one IOA analysis worksheets were generated. These were then compared to the twenty-three NASA FMEAs. The difference in the total number of FMEAs may be attributed predominantly to the fact that NASA has one FMEA per failure mode whereas IOA has multiple failure modes per worksheet. The additional seven IOA assessment worksheets yielded no additional unique FMEAs and are not included in the comparison FMEA count. They are included in the Appendices for completeness. No issues were identified.

<u>Criticality</u>	Number of FMEAs by criticality			<u>Issues</u>
	<u>IOA</u>	<u>NASA</u>	<u>IOA CIL</u>	
2/1R	3	3	3	0
3/1R	15	15	0	0
3/3	5	5	0	0
Total	23	23	3	0

#### 4.4 Assessment Results DBC

Thirty serial digital data buses connect the GPC IOPs to the BTUs via 227 DBCs. The DBCs' functional components are shown in Figure 8. Two failure modes were identified and one worksheet was generated. No issues were identified.

<u>Criticality</u>	Number of FMEAs by criticality			<u>Issues</u>
	<u>IOA</u>	<u>NASA</u>	<u>IOA CIL</u>	
2/1R	1	1	1	0

#### 4.5 Assessment Results DBIA

The DBIAs consists of components required to provide isolation between the Orbiter Launch/Boost Data Buses and the SRBs and associated GSE. Four failure modes were identified and two worksheets were generated. No issues or CILs were identified.

<u>Criticality</u>	Number of FMEAs by criticality			<u>Issues</u>
	<u>IOA</u>	<u>NASA</u>	<u>IOA CIL</u>	
3/2R	1	1	0	0
3/3	1	1	0	0

#### 4.6 Assessment Results MMU

The MMU analysis investigated failures in the individual components of power supply, read and write electronics, tape transport mechanism, MIA and control logic. These are shown functionally in Figure 9. The power switch and RPC were also investigated. Most of the failures were criticality 3/2R. One critical item was identified.

Criticality	Number of MMU related FMEAs by criticality			
	IOA	NASA	IOA CIL	Issues
2/2	1	1	1	0
3/2R	6	6	0	0
3/3	2	2	0	0
Total	9	9	1	0

The IOA 400 through 407, 411 and 412 correspond to NASA FMEAs 05-5-B04-2-1 and 05-5-B04-2-2. These FMEAs are concerned with malfunctions of the MMU unit itself. The difference in number of FMEAs is due to the fact that the IOA analysis considered failures of individual components of the MMU, such as the tape transport mechanism. There was no significant difference in the results. Both IOA and NASA found the criticality to be 3/2R.

Four NASA FMEAs (05-6S-BRPC2-1, 05-6S-BSW2-1, 05-6S-BSW2-2, and an as yet unnumbered new item) correspond to IOA FMEAs 408, 409, and 410. These FMEAs deal with failures of the MMU power switches and RPCs. The only difference in the results in this group is that IOA found the switch failure mode which causes the MMU to remain permanently on to be criticality 3/3 rather than 3/2R. The NASA agreed with this criticality in their reevaluation report.

The IOA FMEA 415 corresponds to NASA FMEA 05-5-B20-1-1. This FMEA deals with failure of the GPC IPL source switch. Both IOA and NASA found the criticality to be 2/2. This is the only CIL item associated with the MMUs.

The NASA FMEAs 05-5-B16-1-1 (GPC IPL switch, criticality 3/2R), 05-5-B18-1-1 (GPC IPL indicator, criticality 3/3), and 05-6S-BRES2-1 (current limit resistor, criticality 3/2R) were analyzed by IOA and are contained in Appendix E. No issues were identified.

#### 4.7 Assessment Results EIU

There were no differences between the hardware and functional criticalities assigned by IOA and NASA on the baseline FMEAs of the Engine Interface Unit (EIU).

##### Number of EIU related FMEAs by Criticality.

<u>Criticality</u>	<u>IOA</u>	<u>NASA</u>	<u>IOA CILs</u>	<u>Issues</u>
1/1	0	2	2	0
2/1R	0	2	2	0
3/1R	5	0	0	0
Totals	5	4	4	0

The NASA presented at the Level III Pre Board (12th and 15th of September, 1986) requests to upgrade the two existing FMEAs from 3/1R to 2/1R. The rationale presented was for a heavy payload. The loss of one engine can cause loss of mission. The IOA can accept this upgrade of criticality based upon a combined payload and vehicle weight requiring three main engines to achieve mission orbit goals.

The second upgrade was requested against the power circuit. The loss of the second circuit causes loss of the EIU. The worst case failure would occur during the last 10 seconds prior to MECO when the crew may not have enough time to respond to manual engine shutdown. This could cause an engine to have fuel or oxidizer depletion with engine running. Previous tests have indicated that pumps fail due to cavitation. In fact, the engine turbine pumps have exploded from cavitations. The IOA agrees with this upgrade and rationale.

There were two new FMEAs proposed by NASA at the pre-board with criticalities of 1/1.- The first was for a failure mode of erroneous output to the GPC. The GPC would then command the pre-valves to close with the engine running. That would cause the high pressure turbine pumps to throw turbine blades which have caused uncontained engine failures. The engine explodes and the crew and vehicle are lost.

The second proposed FMEA deals with the failure of the power switch. The failure mode was both contacts shorted to ground. The loss of power to the EIU causes loss of control of engine throttling and shutdown. If failure occurs in the last six to ten seconds before MECO, the crew would have to manually shutdown the engines. The engines would ingest gas causing pump cavitation and disintegration. This results in loss of crew and vehicle.

Four additional failure modes were analyzed by IOA, but following the pre-board these modes were found to be covered by one of the original baseline FMEAs.

## 5.0 REFERENCES

Reference documentation available from NASA and Rockwell was used in the analysis. The documentation used included the following:

1. ICD 13M15000, Vehicle/Main Engine Interface Control Document, Rev. U, 6-18-85.
2. JSC-18819, DPS Console Handbook, 8-1-84.
3. JSC-19041, Booster-Systems Briefs, 10-1-84.
4. JSC-18820, DPS System Briefs, 4-20-85.
5. VS70-971102, Integrated System Schematic Rev. D, 9-28-85.
6. JSC-17239, Booster Console Handbook, 10-17-85.
7. JSC-12770, Shuttle Flight Operations Manual, Volume 5, Data Processing System, 3-24-84.
8. JSC-12820, STS Operational Flight Rules, Final PCN-3, 6-28-85.
9. JSC-11174, Space Shuttle Systems Handbook, Rev. C, DCN-5, 9-13-85.
10. V72 Vol III, Operations and Maintenance Requirements and Specification Document - Orbiter OMRSD - DPS, 6-13-86.
11. STS82-0032 Orbiter Vehicle Operational Configuration FMEA for DPS Subsystem, Revised 1-28-83.
12. VS70-973099 Integrated System Schematic, Rev A10, 10-17-85.
13. JSC-18730 Orbiter Operational Configuration Critical Items List, 12-17-82.
14. NSTS 22206, Instructions for Preparation of Failure Modes and Effects Analysis (FMEA) and Critical Items List(CIL), 10-10-86.
15. MDAC IOA DPS Working Paper No. 1.0-WP-VA86001-02, 10-24-86.
16. NASA-JSC FMEA & CIL Review Comments,
  - A. DPS - GPC's and MCDS and EPD&C - DPS Items, 9-11-86.
  - B. Engine Interface Unit (EIU), 9-19-86.
  - C. Mass Memory Unit (MMU), 9-19-86.
  - D. MDM, DBC, & DBIA, 8-22-86.

APPENDIX A  
ACRONYMS

A/D - Analog to Digital  
AID - Analog Input Differential  
AIS - Analog Input Single-ended  
ALU - Arithmetic Logic Unit  
AOA - Abort Once Around  
AOD - Analog Output Differential  
ASA - Aero Surface Amplifier  
ATO - Abort To Orbit  
BFC - Backup Flight Controller  
BFS - Backup Flight System  
BITE - Built-In Test Equipment  
BSS - Backup System Services  
BTU - Bus Terminal Unit  
CI - Critical Item  
CIA - Controller Interface Adapter  
CICU - Computer Interface Conditioning Unit  
CIL - Critical Items List  
CPU - Central Processing Unit  
CRIT - Criticality  
CRT - Cathode Ray Tube  
C&W - Caution and Warning System  
DBC - Data Bus Coupler  
DBIA - Data Bus Isolation Amplifier  
DDU - Display Driver Unit  
DEU - Display Electronics Unit  
DIH - Discrete Input High  
DIL - Discrete Input Low  
DMA - Direct Memory Access  
DOH - Discrete Output High  
DOL - Discrete Output Low  
DPS - Data Processing System  
DU - Display Unit  
EIU - Engine Interface Unit  
EVA - Extravehicular Activity  
FA - Flight Aft  
FCOS - Flight Control Operating System  
FF - Flight Forward  
FM - Failure Mode  
FMEA - Failure Mode and Effects Analysis  
GPC - General Purpose Computer  
GSE - Ground Support Equipment  
IMU - Inertial Measurement Unit  
IOA - Independent Orbiter Assessment  
IOM - Input/Output Module  
IOP - Input/Output Processor  
IPL - Initial Program Load  
KU - Keyboard Unit

LA - Launch Aft  
 LF - Launch Forward  
 LL - Launch Left  
 LPS - Launch Processing System  
 LR - Launch Right  
 LRU - Line Replaceable Unit  
 MC - Memory Configuration  
 MCDS - Multifunction CRT Display System  
 MCIU - Manipulator Controller Interface Unit  
 MDAC - McDonnell Douglas Astronautics Company  
 MDM - Multiplexer/Demultiplexer  
 MEC - Main Engine Controller  
 MIA - Multiplexer Interface Adapter  
 MM - Major Mode  
 MMU - Mass Memory Unit  
 MTU - Master Timing Unit  
 NA - Not Applicable  
 NASA - National Aeronautics and Space Administration  
 NSTS - National Space Transportation System  
 OA - Operational Aft  
 OF - Operational Forward  
 OIE - Operational Interface Element  
 OMRSD - Operational Maintenance Requirements and Specifications Document  
 OMS - Orbital Maneuvering System  
 OPS - Operational Sequence  
 PCI - Potential Critical Item  
 PCM - Pulse Code Modulation  
 PF - Payload Forward  
 RCS - Reaction Control System  
 RHC - Rotational Hand Controller  
 RI - Rockwell International  
 RM - Redundancy Management  
 RMS - Remote Manipulator System  
 RPC - Remote Power Controller  
 RS - Redundant Set  
 RTLS - Return To Landing Site  
 SCU - Sequential Control Unit  
 SIO - Serial Input/Output  
 SM - Systems Management  
 SRB - Solid Rocket Booster  
 SSME - Space Shuttle Main Engine  
 STS - Space Transportation System  
 SW - Software  
 TAC - Tacan  
 TAL - Transatlantic Abort Landing  
 TD - Touch Down  
 THC - Translational Hand Controller  
 VDC - Volts Direct Current



## APPENDIX B

### DEFINITIONS, GROUND RULES, AND ASSUMPTIONS

- B.1 Definitions
- B.2 Project Level Ground Rules and Assumptions
- B.3 Subsystem-Specific Ground Rules and Assumptions

APPENDIX B  
DEFINITIONS, GROUND RULES, AND ASSUMPTIONS

B.1 Definitions

Definitions contained in NSTS 22206, Instructions For Preparation of FMEA/CIL, 10 October 1986, were used with the following amplifications and additions.

INTACT ABORT DEFINITIONS:

RTLS - begins at transition to OPS 6 and ends at transition to OPS 9, post-flight

TAL - begins at declaration of the abort and ends at transition to OPS 9, post-flight

AOA - begins at declaration of the abort and ends at transition to OPS 9, post-flight

ATO - begins at declaration of the abort and ends at transition to OPS 9, post-flight

CREDIBLE (CAUSE) - an event that can be predicted or expected in anticipated operational environmental conditions. Excludes an event where multiple failures must first occur to result in environmental extremes

CONTINGENCY CREW PROCEDURES - procedures that are utilized beyond the standard malfunction procedures, pocket checklists, and cue cards

EARLY MISSION TERMINATION - termination of onorbit phase prior to planned end of mission

EFFECTS/RATIONALE - description of the case which generated the highest criticality

HIGHEST CRITICALITY - the highest functional criticality determined in the phase-by-phase analysis

MAJOR MODE (MM) - major sub-mode of software operational sequence (OPS)

MC - Memory Configuration of Primary Avionics Software System (PASS)

MISSION - assigned performance of a specific Orbiter flight with payload/objective accomplishments including orbit phasing and altitude (excludes secondary payloads such as GAS cans, middeck P/L, etc.)

MULTIPLE ORDER FAILURE - describes the failure due to a single cause or event of all units which perform a necessary (critical) function

OFF-NOMINAL CREW PROCEDURES - procedures that are utilized beyond the standard malfunction procedures, pocket checklists, and cue cards

OPS - software operational sequence

PRIMARY MISSION OBJECTIVES - worst case primary mission objectives are equal to mission objectives

PHASE DEFINITIONS:

PRELAUNCH PHASE - begins at launch count-down Orbiter power-up and ends at moding to OPS Major Mode 102 (liftoff)

LIFTOFF MISSION PHASE - begins at SRB ignition (MM 102) and ends at transition out of OPS 1 (Synonymous with ASCENT)

ONORBIT PHASE - begins at transition to OPS 2 or OPS 8 and ends at transition out of OPS 2 or OPS 8

DEORBIT PHASE - begins at transition to OPS Major Mode 301 and ends at first main landing gear touchdown

LANDING/SAFING PHASE - begins at first main gear touchdown and ends with the completion of post-landing safing operations

APPENDIX B  
DEFINITIONS, GROUND RULES, AND ASSUMPTIONS

B.2 IOA Project Level Ground Rules and Assumptions

The philosophy embodied in NSTS 22206, Instructions for Preparation of FMEA/CIL, 10 October 1986, was employed with the following amplifications and additions.

1. The operational flight software is an accurate implementation of the Flight System Software Requirements (FSSRs).

RATIONALE: Software verification is out-of-scope of this task.

2. After liftoff, any parameter which is monitored by system management (SM) or which drives any part of the Caution and Warning System (C&W) will support passage of Redundancy Screen B for its corresponding hardware item.

RATIONALE: Analysis of on-board parameter availability and/or the actual monitoring by the crew is beyond the scope of this task.

3. Any data employed with flight software is assumed to be functional for the specific vehicle and specific mission being flown.

RATIONALE: Mission data verification is out-of-scope of this task.

4. All hardware (including firmware) is manufactured and assembled to the design specifications/drawings.

RATIONALE: Acceptance and verification testing is designed to detect and identify problems before the item is approved for use.

5. All Flight Data File crew procedures will be assumed performed as written, and will not include human error in their performance.

RATIONALE: Failures caused by human operational error are out-of-scope of this task.

6. All hardware analyses will, as a minimum, be performed at the level of analysis existent within NASA/Prime Contractor Orbiter FMEA/CILs, and will be permitted to go to greater hardware detail levels but not lesser.

RATIONALE: Comparison of IOA analysis results with other analyses requires that both analyses be performed to a comparable level of detail.

7. Verification that a telemetry parameter is actually monitored during AOS by ground-based personnel is not required.

RATIONALE: Analysis of mission-dependent telemetry availability and/or the actual monitoring of applicable data by ground-based personnel is beyond the scope of this task.

8. The determination of criticalities per phase is based on the worst case effect of a failure for the phase being analyzed. The failure can occur in the phase being analyzed or in any previous phase, whichever produces the worst case effects for the phase of interest.

RATIONALE: Assigning phase criticalities ensures a thorough and complete analysis.

9. Analysis of wire harnesses, cables and electrical connectors to determine if FMEAs are warranted will not be performed nor FMEAs assessed.

RATIONALE: Analysis was substantially complete prior to NSTS 22206 ground rule redirection.

10. Analysis of welds or brazed joints that cannot be inspected will not be performed nor FMEAs assessed.

RATIONALE: Analysis was substantially complete prior to NSTS 22206 ground rule redirection.

11. Emergency system or hardware will include burst discs and will exclude the EMU Secondary Oxygen Pack (SOP), pressure relief valves and the landing gear pyrotechnics.

RATIONALE: Clarify definition of emergency systems to ensure consistency throughout IOA project.

APPENDIX B  
DEFINITIONS, GROUND RULES, AND ASSUMPTIONS

**B.3 DPS-Specific Ground Rules and Assumptions**

The IOA analysis was performed to the component or assembly level of the DPS subsystem. The analysis considered the worst case effects of the hardware or functional failure on the subsystem, mission, and crew and vehicle safety.

1. Crew procedures that take the two good FCS channels to override following two GPC or two MDM failures are considered in assigning criticality.

**RATIONALE:** Clarifies standard cockpit procedures that can be considered in assigning criticality.

APPENDIX C  
DETAILED ASSESSMENT

This section contains the IOA assessment worksheets generated during the assessment of this subsystem. The information on these worksheets facilitates the comparison of the NASA FMEA/CIL (Pre and Post 51-L) to the IOA detailed analysis worksheets included in Appendix E. Each of these worksheets identifies the NASA FMEA being assessed, corresponding MDAC Analysis Worksheet ID (Appendix E), hardware item, criticality, redundancy screens, and recommendations. For each failure mode, the highest assessed hardware and functional criticality is compared and discrepancies noted as "N" in the compare row under the column where the discrepancy occurred.

LEGEND FOR IOA ASSESSMENT WORKSHEETS  
-----

Hardware Criticalities:

- 1 = Loss of life or vehicle
- 2 = Loss of mission or next failure of any redundant item (like or unlike) could cause loss of life/vehicle
- 3 = All others

Functional Criticalities:

- 1R = Redundant hardware items (like or unlike) all of which, if failed, could cause loss of life or vehicle
- 2R = Redundant hardware items (like or unlike) all of which, if failed, could cause loss of mission

Redundancy Screens A, B and C:

- P = Passed Screen
- F = Failed Screen
- NA = Not Applicable

NASA Data :

- Baseline = NASA FMEA/CIL
- New = Baseline with Proposed Post 51-L Changes

CIL Item :

- X = Included in CIL

Compare Row :

- N = Non compare for that column (deviation)

APPENDIX C  
ASSESSMENT WORKSHEET

ASSESSMENT DATE: 10/06/86  
ASSESSMENT ID: DPS-100  
NASA FMEA #: 05-5-B03-2-1

NASA DATA:  
BASELINE [ X ]  
NEW [ ]

SUBSYSTEM: DPS  
MDAC ID: 100  
ITEM: MDM FF1,FF2,FF3,FF4

LEAD ANALYST: W. A. Haufler

ASSESSMENT:

	CRITICALITY FLIGHT HDW/FUNC	REDUNDANCY SCREENS			CIL ITEM
		A	B	C	
NASA	[ 2 /1R ]	[ P ]	[ P ]	[ P ]	[ X ] *
IOA	[ 3 /1R ]	[ P ]	[ P ]	[ P ]	[ ]
COMPARE	[ N / ]	[ ]	[ ]	[ ]	[ N ]

RECOMMENDATIONS: (If different from NASA)

[ 3 /1R ] [ P ] [ P ] [ P ] [ D ]  
(ADD/DELETE)

\* CIL RETENTION RATIONALE: (If applicable)

ADEQUATE [ X ]  
INADEQUATE [ ]

REMARKS:

SIMULTANEOUS DISSIMILAR FAILURES WERE EXCLUDED FROM THE IOA, MULTIPLE FAILURES ARE INCONSISTENT WITH THE NSTS 22206. IOA RECOMMENDS REPLACING THIS PHRASE IN THIS NASA/RI FMEA'S EFFECTS FIELD "COUPLED WITH AND UNDETECTED FCS FAILURE (IN THE NULL POSITION)," WITH "COUPLED WITH A LIKE FAILURE IN ANOTHER MDM". IOA DID NOT CONSIDER DEGRADED STATE VECTORS. IOA DOES NOT BELIEVE THE LOSS OF TWO STATE VECTORS WILL CAUSE LOSS OF CREW OR VEHICLE. IN THE WORST CASE ON ENTRY, THE LOSS OF THE SECOND STATE VECTOR WILL PERMIT THE ORBITER TO FLY WITH ONE REMAINING STATE VECTOR. IOA DOES NOT CONCUR WITH NASA'S REEVALUATION AND RATIONALE. IOA RECOMMENDS DOWNGRADING HARDWARE CRITICALITY TO 3, THEREBY REMOVING THE FMEA FROM THE CIL.



APPENDIX C  
ASSESSMENT WORKSHEET

ASSESSMENT DATE: 10/06/86  
 ASSESSMENT ID: DPS-101  
 NASA FMEA #: 05-5-B03-2-1

NASA DATA:  
 BASELINE [ X ]  
 NEW [ ]

SUBSYSTEM: DPS  
 MDAC ID: 101  
 ITEM: MDM FF1,FF2,FF3,FF4

LEAD ANALYST: W. A. Haufler

ASSESSMENT:

	CRITICALITY FLIGHT HDW/FUNC	REDUNDANCY SCREENS			CIL ITEM
		A	B	C	
NASA	[ 2 /1R ]	[ P ]	[ P ]	[ P ]	[ X ] *
IOA	[ 3 /1R ]	[ P ]	[ P ]	[ P ]	[ ]
COMPARE	[ N / ]	[ ]	[ ]	[ ]	[ N ]

RECOMMENDATIONS: (If different from NASA)

[ 3 /1R ] [ P ] [ P ] [ P ] [ D ]  
 (ADD/DELETE)

\* CIL RETENTION RATIONALE: (If applicable)

ADEQUATE [ X ]  
 INADEQUATE [ ]

REMARKS:

THIS FAILURE MODE "LOSS OF OUTPUT TO LRU" IS CONSIDERED TO BE COVERED BY THIS ROCKWELL FMEA WITH FAILURE MODE "NO OUTPUT: FAILED MDM PORT - SCU, MIA, A/D, POWER SUPPLIES, OR I/O CARD/CHANNEL FAILURE".

SIMULTANEOUS DISSIMILAR FAILURES WERE EXCLUDED FROM THE IOA. MULTIPLE FAILURES ARE INCONSISTENT WITH THE NSTS 22206.

IOA RECOMMENDS REPLACING THIS PHRASE IN THIS NASA/RI FMEA'S EFFECTS FIELD, "COUPLED WITH AND UNDETECTED FCS FAILURE (IN THE NULL POSITION)", WITH "COUPLED WITH A LIKE FAILURE IN ANOTHER MDM". IOA DID NOT CONSIDER DEGRADED STATE VECTORS.

IOA DOES NOT BELIEVE THE LOSS OF TWO STATE VECTORS WILL CAUSE LOSS OF CREW OR VEHICLE. IN THE WORST CASE ON ENTRY, THE LOSS OF THE SECOND STATE VECTOR WILL PERMIT THE ORBITER TO FLY WITH ONE REMAINING STATE VECTOR.

IOA DOES NOT CONCUR WITH NASA'S REEVALUATION AND RATIONALE. IOA RECOMMENDS DOWNGRADING HARDWARE CRITICALITY TO 3, THEREBY REMOVING THE FMEA FROM THE CIL.

APPENDIX C  
ASSESSMENT WORKSHEET

ASSESSMENT DATE: 10/06/86  
 ASSESSMENT ID: DPS-102  
 NASA FMEA #: 05-5-B03-2-2

NASA DATA:  
 BASELINE [ X ]  
 NEW [ ]

SUBSYSTEM: DPS  
 MDAC ID: 102  
 ITEM: MDM FF1,FF2,FF3,FF4

LEAD ANALYST: W. A. Haufler

ASSESSMENT:

	CRITICALITY FLIGHT HDW/FUNC	REDUNDANCY SCREENS			CIL ITEM
		A	B	C	
NASA	[ 2 /1R ]	[ P ]	[ P ]	[ P ]	[ X ] *
IOA	[ 3 /1R ]	[ P ]	[ P ]	[ P ]	[ ]
COMPARE	[ N / ]	[ ]	[ ]	[ ]	[ N ]

RECOMMENDATIONS: (If different from NASA)

[ / ] [ ] [ ] [ ] [ ]  
 (ADD/DELETE)

\* CIL RETENTION RATIONALE: (If applicable)

ADEQUATE [ X ]  
 INADEQUATE [ ]

REMARKS:

IOD DID NOT INITIALLY CONSIDER DEGRADED STATE VECTORS.  
 IOA DOES CONCUR WITH NASA'S REEVALUATION AND RATIONALE.  
 NO DIFFERENCES.

APPENDIX C  
ASSESSMENT WORKSHEET

ASSESSMENT DATE: 10/06/86  
 ASSESSMENT ID: DPS-103  
 NASA FMEA #: 05-5-B03-2-2

NASA DATA:  
 BASELINE [ X ]  
 NEW [ ]

SUBSYSTEM: DPS  
 MDAC ID: 103  
 ITEM: MDM FF1,FF2,FF3,FF4

LEAD ANALYST: W. A. Haufler

ASSESSMENT:

	CRITICALITY FLIGHT HDW/FUNC	REDUNDANCY SCREENS			CIL ITEM
		A	B	C	
NASA	[ 2 /LR ]	[ P ]	[ P ]	[ P ]	[ X ] *
IOA	[ 3 /LR ]	[ P ]	[ P ]	[ P ]	[ ]
COMPARE	[ N / ]	[ ]	[ ]	[ ]	[ N ]

RECOMMENDATIONS: (If different from NASA)

[ / ] [ ] [ ] [ ] [ ]  
 (ADD/DELETE)

\* CIL RETENTION RATIONALE: (If applicable)

ADEQUATE [ X ]  
 INADEQUATE [ ]

REMARKS:

THIS FAILURE MODE "ERRONEOUS OUTPUT TO LRU" IS CONSIDERED TO BE COVERED BY THIS ROCKWELL FMEA WITH FAILURE MODE "ERRONEOUS OUTPUT: ADDRESS CHECK FAILURE, DATA ERROR TO MDM MODULE, OR MODULE SELECT FAILURE".

IOA DID NOT INITIALLY CONSIDER DEGRADED STATE VECTORS.  
 IOA DOES CONCUR WITH NASA'S REEVALUATION AND RATIONALE.  
 NO DIFFERENCES.

APPENDIX C  
ASSESSMENT WORKSHEET

ASSESSMENT DATE: 10/06/86  
ASSESSMENT ID: DPS-104  
NASA FMEA #: NONE

NASA DATA:  
BASELINE [ ]  
NEW [ ]

SUBSYSTEM: DPS  
MDAC ID: 104  
ITEM: MDM FF1,FF2,FF3,FF4

LEAD ANALYST: W. A. Haufler

ASSESSMENT:

	CRITICALITY	REDUNDANCY SCREENS			CIL
	FLIGHT HDW/FUNC	A	B	C	ITEM
NASA	[ / ]	[ ]	[ ]	[ ]	[ ] *
IOA	[ 3 /1R ]	[ P ]	[ P ]	[ P ]	[ ]
COMPARE	[ N /N ]	[ N ]	[ N ]	[ N ]	[ ]

RECOMMENDATIONS: (If different from NASA)

[ / ] [ ] [ ] [ ] [ ]  
(ADD/DELETE)

\* CIL RETENTION RATIONALE: (If applicable)

ADEQUATE [ ]  
INADEQUATE [ ]

REMARKS:

ROCKWELL/NASA DID NOT COVER THIS FAILURE MODE.  
THIS FAILURE MODE, "PREMATURE OPERATION TO GPC", IS DETERMINED TO  
BE NON-CREDIBLE.

APPENDIX C  
ASSESSMENT WORKSHEET

ASSESSMENT DATE: 10/06/86  
 ASSESSMENT ID: DPS-105  
 NASA FMEA #: NONE

NASA DATA:  
 BASELINE [    ]  
 NEW [    ]

SUBSYSTEM: DPS  
 MDAC ID: 105  
 ITEM: MDM FF1,FF2,FF3,FF4

LEAD ANALYST: W. A. Haufler

ASSESSMENT:

	CRITICALITY FLIGHT HDW/FUNC	REDUNDANCY SCREENS			CIL ITEM
		A	B	C	
NASA	[    /    ]	[    ]	[    ]	[    ]	[    ] *
IOA	[ 3 /1R ]	[ P ]	[ P ]	[ P ]	[    ]
COMPARE	[ N /N ]	[ N ]	[ N ]	[ N ]	[    ]

RECOMMENDATIONS: (If different from NASA)

[    /    ]    [    ]    [    ]    [    ]    [    ]  
 (ADD/DELETE)

\* CIL RETENTION RATIONALE: (If applicable)

ADEQUATE [    ]  
 INADEQUATE [    ]

REMARKS:

THIS FAILURE MODE "PREMATURE OPERATION TO LRU" IS DETERMINED TO BE NON-CREDIBLE.

APPENDIX C  
ASSESSMENT WORKSHEET

ASSESSMENT DATE: 10/06/96  
 ASSESSMENT ID: DPS-106  
 NASA FMEA #: 05-5-B03-2-2

NASA DATA:  
 BASELINE [ X ]  
 NEW [ ]

SUBSYSTEM: DPS  
 MDAC ID: 106  
 ITEM: MDM FF1,FF2,FF3,FF4

LEAD ANALYST: W. A. Haufler

ASSESSMENT:

	CRITICALITY FLIGHT HDW/FUNC	REDUNDANCY SCREENS			CIL ITEM
		A	B	C	
NASA	[ 2 / 1R ]	[ P ]	[ P ]	[ P ]	[ X ] *LAW
IOA	[ 3 / 1R ]	[ P ]	[ P ]	[ P ]	[ ]
COMPARE	[ N / ]	[ ]	[ ]	[ ]	[ N ]

RECOMMENDATIONS: (If different from NASA)

[ / ] [ ] [ ] [ ] [ ] (ADD/DELETE)

\* CIL RETENTION RATIONALE: (If applicable)

ADEQUATE [ X ]  
 INADEQUATE [ ]

REMARKS:

IOA DID NOT INITIALLY CONSIDER DEGRADED STATE VECTORS.  
 IOA DOES CONCUR WITH NASA'S REEVALUATION AND RATIONALE.  
 NO DIFFERENCES.

APPENDIX C  
ASSESSMENT WORKSHEET

ASSESSMENT DATE: 10/07/86  
 ASSESSMENT ID: DPS-107  
 NASA FMEA #: 05-5-B03-2-2

NASA DATA:  
 BASELINE [ X ]  
 NEW [ ]

SUBSYSTEM: DPS  
 MDAC ID: 107  
 ITEM: MDM FF1,FF2,FF3,FF4

LEAD ANALYST: W. A. Haufler

ASSESSMENT:

	CRITICALITY FLIGHT HDW/FUNC	REDUNDANCY SCREENS			CIL ITEM
		A	B	C	
NASA	[ 2 /1R ]	[ P ]	[ P ]	[ P ]	[ X ] *
IOA	[ 3 /1R ]	[ P ]	[ P ]	[ P ]	[ ]
COMPARE	[ N / ]	[ ]	[ ]	[ ]	[ N ]

RECOMMENDATIONS: (If different from NASA)

[ / ] [ ] [ ] [ ] [ ]  
 (ADD/DELETE)

\* CIL RETENTION RATIONALE: (If applicable)

ADEQUATE [ X ]  
 INADEQUATE [ ]

REMARKS:

THIS FAILURE MODE "STUCK ON A CONSTANT OUTPUT TO LRU" IS  
 CONSIDERED TO BE COVERED BY THIS ROCKWELL FMEA WITH FAILURE MODE  
 "ERRONEOUS OUTPUT: ADDRESS CHECK FAILURE, DATA ERROR TO MDM  
 MODULE, OR MODULE SELECT FAILURE".  
 IOA DID NOT INITIALLY CONSIDER DEGRADED STATE VECTORS.  
 IOA DOES CONCUR WITH NASA'S REEVALUATION AND RATIONALE.  
 NO DIFFERENCES.

APPENDIX C  
ASSESSMENT WORKSHEET

ASSESSMENT DATE: 10/06/86  
 ASSESSMENT ID: DPS-108  
 NASA FMEA #: 05-5-B03-2-1

NASA DATA:  
 BASELINE [ X ]  
 NEW [ ]

SUBSYSTEM: DPS  
 MDAC ID: 108  
 ITEM: MDM FF1,FF2,FF3,FF4

LEAD ANALYST: W. A. Haufler

ASSESSMENT:

	CRITICALITY FLIGHT HDW/FUNC	REDUNDANCY SCREENS			CIL ITEM
		A	B	C	
NASA	[ 2 /1R ]	[ P ]	[ P ]	[ P ]	[ X ] *
IOA	[ 3 /1R ]	[ P ]	[ P ]	[ P ]	[ ]
COMPARE	[ N / ]	[ ]	[ ]	[ ]	[ N ]

RECOMMENDATIONS: (If different from NASA)

[ 3 /1R ] [ P ] [ P ] [ P ] [ D ]  
 (ADD/DELETE)

\* CIL RETENTION RATIONALE: (If applicable)

ADEQUATE [ X ]  
 INADEQUATE [ ]

REMARKS:

THIS FAILURE MODE "FALSELY STUCK ON BUSY MODE" IS CONSIDERED TO BE COVERED BY THIS ROCKWELL FMEA WITH FAILURE MODE "NO OUTPUT: FAILED MDM PORT - SCU, MIA, A/D, POWER SUPPLIES, OR I/O CARD/CHANNEL FAILURE". SIMULTANEOUS DISSIMILAR FAILURES WERE EXCLUDED FROM THE IOA. MULTIPLE FAILURES ARE INCONSISTENT WITH THE NSTS 22206. IOA RECOMMENDS REPLACING THIS PHRASE IN THE NASA/RI FMEA'S EFFECTS FIELD, "COUPLED WITH AN UNDETECTED FCS FAILURE (IN THE NULL POSITION)", WITH "COUPLED WITH A LIKE FAILURE IN ANOTHER MDM". IOA DID NOT CONSIDER DEGRADED STATE VECTORS. IOA DOES NOT BELIEVE THE LOSS OF TWO STATE VECTORS WILL CAUSE LOSS OF CREW OR VEHICLE. IN THE WORST CASE ON ENTRY, THE LOSS OF THE SECOND STATE VECTOR WILL PERMIT THE ORBITER TO FLY WITH ONE REMAINING STATE VECTOR. IOA DOES NOT CONCUR WITH NASA'S REEVALUATION AND RATIONALE. IOA RECOMMENDS DOWNGRADING HARDWARE CRITICALITY TO 3, THEREBY REMOVING THE FMEA FROM THE CIL.



APPENDIX C  
ASSESSMENT WORKSHEET

ASSESSMENT DATE: 10/06/86  
 ASSESSMENT ID: DPS-120  
 NASA FMEA #: 05-5-B03-1-1

NASA DATA:  
 BASELINE [ X ]  
 NEW [ ]

SUBSYSTEM: DPS  
 MDAC ID: 120  
 ITEM: MDM FA1,FA2,FA3,FA4

LEAD ANALYST: W. A. Haufler

ASSESSMENT:

	CRITICALITY FLIGHT HDW/FUNC	REDUNDANCY SCREENS			CIL ITEM
		A	B	C	
NASA	[ 2 /1R ]	[ P ]	[ P ]	[ P ]	[ X ] *
IOA	[ 3 /1R ]	[ P ]	[ P ]	[ P ]	[ ]
COMPARE	[ N / ]	[ ]	[ ]	[ ]	[ N ]

RECOMMENDATIONS: (If different from NASA)

[ 3 /1R ] [ P ] [ P ] [ P ] [ D ]  
 (ADD/DELETE)

\* CIL RETENTION RATIONALE: (If applicable)

ADEQUATE [ X ]  
 INADEQUATE [ ]

REMARKS:

SIMULTANEOUS DISSIMILAR FAILURES WERE EXCLUDED FROM THE IOA.  
 MULTIPLE FAILURES ARE INCONSISTENT WITH THE NSTS 22206.  
 IOA RECOMMENDS REPLACING THIS PHRASE IN THIS NASA/RI FMEA'S  
 EFFECTS FIELD, "COUPLED WITH AN UNDETECTED FCS FAILURE (IN THE  
 NULL POSITION)", WITH "COUPLED WITH A LIKE FAILURE IN ANOTHER  
 MDM".  
 IOA DOES NOT CONCUR WITH NASA'S REEVALUATION AND RATIONALE.  
 IOA RECOMMENDS DOWNGRADING THE HARDWARE CRITICALITY TO 3, THEREBY  
 REMOVING THE FMEA FROM THE CIL.

APPENDIX C  
ASSESSMENT WORKSHEET

ASSESSMENT DATE: 10/06/86  
ASSESSMENT ID: DPS-121  
NASA FMEA #: 05-5-B03-1-1

NASA DATA:  
BASELINE [ X ]  
NEW [ ]

SUBSYSTEM: DPS  
MDAC ID: 121  
ITEM: MDM FA1,FA2,FA3,FA4

LEAD ANALYST: W. A. Haufler

ASSESSMENT:

	CRITICALITY FLIGHT HDW/FUNC	REDUNDANCY SCREENS			CIL ITEM
		A	B	C	
NASA	[ 2 /1R ]	[ P ]	[ P ]	[ P ]	[ X ] *
IOA	[ 3 /1R ]	[ P ]	[ P ]	[ P ]	[ ]
COMPARE	[ N / ]	[ ]	[ ]	[ ]	[ N ]

RECOMMENDATIONS: (If different from NASA)

[ 3 /1R ] [ P ] [ P ] [ P ] [ D ]  
(ADD/DELETE)

\* CIL RETENTION RATIONALE: (If applicable)

ADEQUATE [ X ]  
INADEQUATE [ ]

REMARKS:

THIS FAILURE MODE "NO OUTPUT TO LRU" IS CONSIDERED TO BE COVERED BY THE ROCKWELL FMEA WITH FAILURE MODE "NO OUTPUT: FAILED MDM PORT - SCU, MIA, A/D, POWER SUPPLIES, OR I/O CARD/CHANNEL FAILURE".

SIMULTANEOUS DISSIMILAR FAILURES WERE EXCLUDED FROM THE IOA.

MULTIPLE FAILURES ARE INCONSISTENT WITH THE NSTS 22206.

IOA RECOMMENDS REPLACING THIS PHRASE IN THIS NASA/RI FMEA'S EFFECTS FIELD, "COUPLED WITH AN UNDETECTED FCS FAILURE (IN THE NULL POSITION)", WITH "COUPLED WITH A LIKE FAILURE IN ANOTHER MDM".

IOA DOES NOT CONCUR WITH NASA'S REEVALUATION AND RATIONALE.

IOA RECOMMENDS DOWNGRADING THE HARDWARE CRITICALITY TO 3, THEREBY REMOVING THE FMEA FROM THE CIL.

APPENDIX C  
ASSESSMENT WORKSHEET

ASSESSMENT DATE: 10/06/86  
 ASSESSMENT ID: DPS-122  
 NASA FMEA #: 05-5-B03-1-2

NASA DATA:  
 BASELINE [ X ]  
 NEW [ ]

SUBSYSTEM: DPS  
 MDAC ID: 122  
 ITEM: MDM FA1,FA2,FA3,FA4

LEAD ANALYST: W. A. Haufler

ASSESSMENT:

	CRITICALITY FLIGHT HDW/FUNC	REDUNDANCY SCREENS			CIL ITEM
		A	B	C	
NASA	[ 2 /1R ]	[ P ]	[ P ]	[ P ]	[ X ] *
IOA	[ 3 /1R ]	[ P ]	[ P ]	[ P ]	[ ]
COMPARE	[ N / ]	[ ]	[ ]	[ ]	[ N ]

RECOMMENDATIONS: (If different from NASA)

[ / ] [ ] [ ] [ ] [ ]  
 (ADD/DELETE)

\* CIL RETENTION RATIONALE: (If applicable)

ADEQUATE [ X ]  
 INADEQUATE [ ]

REMARKS:

IOA DID NOT INITIALLY CONSIDER E/T SEP DOORS CLOSING PREMATURELY.  
 IOA DOES CONCUR WITH NASA'S REEVALUATION AND RATIONALE.  
 NO DIFFERENCES.

APPENDIX C  
ASSESSMENT WORKSHEET

ASSESSMENT DATE: 10/06/86  
 ASSESSMENT ID: DPS-123  
 NASA FMEA #: 05-5-B03-1-2

NASA DATA:  
 BASELINE [ X ]  
 NEW [ ]

SUBSYSTEM: DPS  
 MDAC ID: 123  
 ITEM: MDM FA1, FA2, FA3, FA4

LEAD ANALYST: W. A. Haufler

ASSESSMENT:

	CRITICALITY FLIGHT HDW/FUNC	REDUNDANCY SCREENS			CIL ITEM
		A	B	C	
NASA	[ 2 /1R ]	[ P ]	[ P ]	[ P ]	[ X ] *
IOA	[ 3 /1R ]	[ P ]	[ P ]	[ P ]	[ ]
COMPARE	[ N / ]	[ ]	[ ]	[ ]	[ N ]

RECOMMENDATIONS: (If different from NASA)

[ / ] [ ] [ ] [ ] [ ]  
 (ADD/DELETE)

\* CIL RETENTION RATIONALE: (If applicable)

ADEQUATE [ X ]  
 INADEQUATE [ ]

REMARKS:  
 THIS FAILURE MODE "ERRONEOUS OUTPUT TO LRU" IS CONSIDERED TO BE COVERED BY THIS ROCKWELL FMEA WITH FAILURE MODE "ERRONEOUS OUTPUT: ADDRESS CHECK FAILURE, DATA ERROR TO MDM MODULE, OR MODULE SELECT FAILURE".  
 IOA DOES CONCUR WITH NASA'S REEVALUATION AND RATIONALE.  
 NO DIFFERENCES.

APPENDIX C  
ASSESSMENT WORKSHEET

ASSESSMENT DATE: 10/06/86  
 ASSESSMENT ID: DPS-124  
 NASA FMEA #: NONE

NASA DATA:  
 BASELINE [    ]  
 NEW [    ]

SUBSYSTEM: DPS  
 MDAC ID: 124  
 ITEM: MDM FA1,FA2,FA3,FA4

LEAD ANALYST: W. A. Haufler

ASSESSMENT:

	CRITICALITY FLIGHT HDW/FUNC	REDUNDANCY SCREENS			CIL ITEM
		A	B	C	
NASA	[ / ]	[ ]	[ ]	[ ]	*
IOA	[ 3 /1R ]	[ P ]	[ P ]	[ P ]	
COMPARE	[ N /N ]	[ N ]	[ N ]	[ N ]	

RECOMMENDATIONS: (If different from NASA)

[ / ] [ ] [ ] [ ] [ ]  
 (ADD/DELETE)

\* CIL RETENTION RATIONALE: (If applicable)

ADEQUATE [    ]  
 INADEQUATE [    ]

REMARKS:

ROCKWELL/NASA DID NOT COVER THIS FAILURE MODE.  
 THIS FAILURE MODE, "PREMATURE OPERATION TO GPC", IS DETERMINED TO  
 BE NON-CREDIBLE.

APPENDIX C  
ASSESSMENT WORKSHEET

ASSESSMENT DATE: 10/06/86  
 ASSESSMENT ID: DPS-125  
 NASA FMEA #: NONE

NASA DATA:  
 BASELINE [ ]  
 NEW [ ]

SUBSYSTEM: DPS  
 MDAC ID: 125  
 ITEM: MDM FA1, FA2, FA3, FA4

LEAD ANALYST: W. A. Haufler

ASSESSMENT:

	CRITICALITY FLIGHT HDW/FUNC	REDUNDANCY SCREENS			CIL ITEM
		A	B	C	
NASA	[ / ]	[ ]	[ ]	[ ]	[ ] *
IOA	[ 3 / 1R ]	[ P ]	[ P ]	[ P ]	[ ]
COMPARE	[ N / N ]	[ N ]	[ N ]	[ N ]	[ ]

RECOMMENDATIONS: (If different from NASA)

[ / ] [ ] [ ] [ ] [ ] (ADD/DELETE)

\* CIL RETENTION RATIONALE: (If applicable)

ADEQUATE [ ]  
 INADEQUATE [ ]

REMARKS:

ROCKWELL/NASA DID NOT COVER THIS FAILURE MODE.  
 THIS FAILURE MODE, "PREMATURE OPERATION TO LRU", IS DETERMINED TO  
 BE NON-CREDIBLE.

APPENDIX C  
ASSESSMENT WORKSHEET

ASSESSMENT DATE: 10/06/86  
 ASSESSMENT ID: DPS-126  
 NASA FMEA #: 05-5-B03-1-2

NASA DATA:  
 BASELINE [ X ]  
 NEW [ ]

SUBSYSTEM: DPS  
 MDAC ID: 126  
 ITEM: MDM FA1, FA2, FA3, FA4

LEAD ANALYST: W. A. Haufler

ASSESSMENT:

	CRITICALITY FLIGHT HDW/FUNC	REDUNDANCY SCREENS			CIL ITEM
		A	B	C	
NASA	[ 2 /1R ]	[ P ]	[ P ]	[ P ]	[ X ] *
IOA	[ 3 /1R ]	[ P ]	[ P ]	[ P ]	[ ]
COMPARE	[ N / ]	[ ]	[ ]	[ ]	[ N ]

RECOMMENDATIONS: (If different from NASA)

[ / ] [ ] [ ] [ ] [ ]  
 (ADD/DELETE)

\* CIL RETENTION RATIONALE: (If applicable)

ADEQUATE [ X ]  
 INADEQUATE [ ]

REMARKS:

IOA DID NOT INITIALLY CONSIDER E/T SEP DOORS CLOSING PREMATURELY.  
 IOA DOES CONCUR WITH NASA'S REEVALUATION AND RATIONALE.  
 NO DIFFERENCES.

APPENDIX C  
ASSESSMENT WORKSHEET

ASSESSMENT DATE: 10/06/86  
 ASSESSMENT ID: DPS-127  
 NASA FMEA #: 05-5-B03-1-2

NASA DATA:  
 BASELINE [ X ]  
 NEW [ ]

SUBSYSTEM: DPS  
 MDAC ID: 127  
 ITEM: MDM FA1,FA2,FA3,FA4

LEAD ANALYST: W. A. Haufler

ASSESSMENT:

	CRITICALITY FLIGHT HDW/FUNC	REDUNDANCY SCREENS			CIL ITEM
		A	B	C	
NASA	[ 2 /1R ]	[ P ]	[ P ]	[ P ]	[ X ] *
IOA	[ 3 /1R ]	[ P ]	[ P ]	[ P ]	[ ]
COMPARE	[ N / ]	[ ]	[ ]	[ ]	[ N ]

RECOMMENDATIONS: (If different from NASA)

[ / ] [ ] [ ] [ ] [ ] (ADD/DELETE)

\* CIL RETENTION RATIONALE: (If applicable)

ADEQUATE [ X ]  
 INADEQUATE [ ]

REMARKS:

THIS FAILURE MODE "STUCK ON A CONSTANT OUTPUT TO LRU" IS CONSIDERED TO BE COVERED BY THIS ROCKWELL FMEA WITH FAILURE MODE "ERRONEOUS OUTPUT: ADDRESS CHECK FAILURE, DATA ERROR TO MDM MODULE, OR MODULE SELECT FAILURE".  
 IOA DID NOT INITIALLY CONSIDER E/T SEP DOORS CLOSING PREMATURELY. IOA DOES CONCUR WITH NASA'S REEVALUATION AND RATIONALE.  
 NO DIFFERENCES.



APPENDIX C  
ASSESSMENT WORKSHEET

ASSESSMENT DATE: 10/06/86  
 ASSESSMENT ID: DPS-128  
 NASA FMEA #: 05-5-B03-1-1

NASA DATA:  
 BASELINE [ X ]  
 NEW [ ]

SUBSYSTEM: DPS  
 MDAC ID: 128  
 ITEM: MDM FA1,FA2,FA3,FA4

LEAD ANALYST: W. A. Haufler

ASSESSMENT:

	CRITICALITY FLIGHT HDW/FUNC	REDUNDANCY SCREENS			CIL ITEM
		A	B	C	
NASA	[ 2 /1R ]	[ P ]	[ P ]	[ P ]	[ X ] *
IOA	[ 3 /1R ]	[ P ]	[ P ]	[ P ]	[ ]
COMPARE	[ N / ]	[ ]	[ ]	[ ]	[ N ]

RECOMMENDATIONS: (If different from NASA)

[ 3 /1R ] [ P ] [ P ] [ P ] [ ]  
 (ADD/DELETE)

\* CIL RETENTION RATIONALE: (If applicable)

ADEQUATE [ X ]  
 INADEQUATE [ ]

REMARKS:

THIS FAILURE MODE "FALSELY STUCK ON BUSY MODE" IS CONSIDERED TO BE COVERED BY THIS ROCKWELL FMEA WITH FAILURE MODE "NO OUTPUT: FAILED MDM PORT-SCU, MIA, A/D, POWER SUPPLIES, OR I/O CARD/CHANNEL FAILURE".

SIMULTANEOUS DISSIMILAR FAILURES WERE EXCLUDED FROM THE IOA. MULTIPLE FAILURES ARE INCONSISTENT WITH THE NSTS 22206. IOA RECOMMENDS REPLACING THIS PHRASE IN THIS NASA/RI FMEA'S EFFECTS FIELD, "COUPLED WITH AN UNDETECTED FCS FAILURE (IN THE NULL POSITION)", WITH "COUPLED WITH A LIKE FAILURE IN ANOTHER MDM."

IOA DOES NOT CONCUR WITH NASA'S REEVALUATION AND RATIONALE.

APPENDIX C  
ASSESSMENT WORKSHEET

ASSESSMENT DATE: 10/06/86  
 ASSESSMENT ID: DPS-140  
 NASA FMEA #: 05-5-B03-5-1

NASA DATA:  
 BASELINE [ X ]  
 NEW [ ]

SUBSYSTEM: DPS  
 MDAC ID: 140  
 ITEM: MDM PF1,PF2

LEAD ANALYST: W. A. Haufler

ASSESSMENT:

	CRITICALITY FLIGHT HDW/FUNC	REDUNDANCY SCREENS			CIL ITEM
		A	B	C	
NASA	[ 2 /1R ]	[ P ]	[ P ]	[ P ]	[ X ] *
IOA	[ 3 /1R ]	[ P ]	[ P ]	[ P ]	[ ]
COMPARE	[ N / ]	[ ]	[ ]	[ ]	[ N ]

RECOMMENDATIONS: (If different from NASA)

[ / ] [ ] [ ] [ ] [ ] (ADD/DELETE)

\* CIL RETENTION RATIONALE: (If applicable)

ADEQUATE [ X ]  
 INADEQUATE [ ]

REMARKS:

IOA DID NOT INITIALLY CONSIDER LOSS OF PAYLOAD BAY DOORS CLOSE  
 COMMAND.  
 IOA DOES CONCUR WITH NASA'S REEVALUATION AND RATIONALE.  
 NO DIFFERENCES.

APPENDIX C  
ASSESSMENT WORKSHEET

ASSESSMENT DATE: 10/06/86  
 ASSESSMENT ID: DPS-141  
 NASA FMEA #: 05-5-B03-5-1

NASA DATA:  
 BASELINE [ X ]  
 NEW [ ]

SUBSYSTEM: DPS  
 MDAC ID: 141  
 ITEM: MDM PF1,PF2

LEAD ANALYST: W. A. Haufler

ASSESSMENT:

	CRITICALITY FLIGHT HDW/FUNC	REDUNDANCY SCREENS			CIL ITEM
		A	B	C	
NASA	[ 2 /1R ]	[ P ]	[ P ]	[ P ]	[ X ] *
IOA	[ 3 /1R ]	[ P ]	[ P ]	[ P ]	[ ]
COMPARE	[ N / ]	[ ]	[ ]	[ ]	[ N ]

RECOMMENDATIONS: (If different from NASA)

[ / ] [ ] [ ] [ ] [ ] (ADD/DELETE)

\* CIL RETENTION RATIONALE: (If applicable)

ADEQUATE [ X ]  
 INADEQUATE [ ]

REMARKS:

THIS FAILURE MODE "LOSS OF OUTPUT TO LRU" IS CONSIDERED TO BE COVERED BY THIS ROCKWELL FMEA WITH FAILURE MODE "NO OUTPUT: FAILED MDM PORT-SCU, MIA, A/D, POWER SUPPLIES, OR I/O CARD/CHANNEL FAILURE".  
 IOA DID NOT INITIALLY CONSIDER LOSS OF PAYLOAD BAY DOORS CLOSE COMMAND.  
 IOA DOES CONCUR WITH NASA'S REEVALUATION AND RATIONALE.  
 NO DIFFERENCES.

APPENDIX C  
ASSESSMENT WORKSHEET

ASSESSMENT DATE: 10/06/86  
 ASSESSMENT ID: DPS-142  
 NASA FMEA #: 05-5-B03-5-2

NASA DATA:  
 BASELINE [ X ]  
 NEW [ ]

SUBSYSTEM: DPS  
 MDAC ID: 142  
 ITEM: MDM PF1,PF2

LEAD ANALYST: W. A. Haufler

ASSESSMENT:

	CRITICALITY FLIGHT HDW/FUNC	REDUNDANCY SCREENS			CIL ITEM
		A	B	C	
NASA	[ 2 /1R ]	[ P ]	[ P ]	[ P ]	[ X ] *
IOA	[ 3 /1R ]	[ P ]	[ P ]	[ P ]	[ ]
COMPARE	[ N / ]	[ ]	[ ]	[ ]	[ N ]

RECOMMENDATIONS: (If different from NASA)

[ / ] [ ] [ ] [ ] [ ]  
 (ADD/DELETE)

\* CIL RETENTION RATIONALE: (If applicable)

ADEQUATE [ X ]  
 INADEQUATE [ ]

REMARKS:

IOA DID NOT INITIALLY CONSIDER INADVERTENT COMMAND TO PAYLOAD BAY DOOR'S LATCH TO UNLATCH.  
 IOA DOES CONCUR WITH NASA'S REEVALUATION AND RATIONALE.  
 NO DIFFERENCES.

APPENDIX C  
ASSESSMENT WORKSHEET

ASSESSMENT DATE: 10/06/86  
 ASSESSMENT ID: DPS-143  
 NASA FMEA #: 05-5-B03-5-2

NASA DATA:  
 BASELINE [ X ]  
 NEW [ ]

SUBSYSTEM: DPS  
 MDAC ID: 143  
 ITEM: MDM PFl,PF2

LEAD ANALYST: W. A. Haufler

ASSESSMENT:

	CRITICALITY FLIGHT HDW/FUNC	REDUNDANCY SCREENS			CIL ITEM
		A	B	C	
NASA	[ 2 /1R ]	[ P ]	[ P ]	[ P ]	[ X ] *
IOA	[ 3 /1R ]	[ P ]	[ P ]	[ P ]	[ ]
COMPARE	[ N / ]	[ ]	[ ]	[ ]	[ N ]

RECOMMENDATIONS: (If different from NASA)

[ / ] [ ] [ ] [ ] [ ] (ADD/DELETE)

\* CIL RETENTION RATIONALE: (If applicable)

ADEQUATE [ X ]  
 INADEQUATE [ ]

REMARKS:

THIS FAILURE MODE "ERRONEOUS OUTPUT TO LRU" IS CONSIDERED TO BE COVERED BY THIS ROCKWELL FMEA WITH FAILURE MODE "ERRONEOUS OUTPUT: ADDRESS CHECK FAILURE, DATA ERROR TO MDM MODULE, OR MODULE SELECT FAILURE".

IOA DID NOT INITIALLY CONSIDER INADVERTENT COMMAND TO PAYLOAD BAY DOOR'S LATCH TO UNLATCH.

IOA DOES CONCUR WITH NASA'S REEVALUATION AND RATIONALE.

NO DIFFERENCES.

APPENDIX C  
ASSESSMENT WORKSHEET

ASSESSMENT DATE: 10/06/86  
 ASSESSMENT ID: DPS-144  
 NASA FMEA #: NONE

NASA DATA:  
 BASELINE [ ]  
 NEW [ ]

SUBSYSTEM: DPS  
 MDAC ID: 144  
 ITEM: MDM PF1, PF2

LEAD ANALYST: W. A. Haufler

ASSESSMENT:

	CRITICALITY FLIGHT HDW/FUNC	REDUNDANCY SCREENS			CIL ITEM
		A	B	C	
NASA	[ / ]	[ ]	[ ]	[ ]	[ ] *
IOA	[ 3 / 1R ]	[ P ]	[ P ]	[ P ]	[ ]
COMPARE	[ N / N ]	[ N ]	[ N ]	[ N ]	[ ]

RECOMMENDATIONS: (If different from NASA)

[ / ] [ ] [ ] [ ] [ ]  
 (ADD/DELETE)

\* CIL RETENTION RATIONALE: (If applicable)

ADEQUATE [ ]  
 INADEQUATE [ ]

REMARKS:

ROCKWELL/NASA DID NOT COVER THIS FAILURE MODE.  
 THIS FAILURE MODE, "PREMATURE OPERATION TO GPC", IS DETERMINED TO  
 BE NON-CREDIBLE.

APPENDIX C  
ASSESSMENT WORKSHEET

ASSESSMENT DATE: 10/06/86  
 ASSESSMENT ID: DPS-145  
 NASA FMEA #: NONE

NASA DATA:  
 BASELINE [    ]  
 NEW [    ]

SUBSYSTEM: DPS  
 MDAC ID: 145  
 ITEM: MDM PF1,PF2

LEAD ANALYST: W. A. Haufler

ASSESSMENT:

	CRITICALITY FLIGHT HDW/FUNC	REDUNDANCY SCREENS			CIL ITEM
		A	B	C	
NASA	[    /    ]	[    ]	[    ]	[    ]	[    ] *
IOA	[ 3 /1R ]	[ P ]	[ P ]	[ P ]	[    ]
COMPARE	[ N /N ]	[ N ]	[ N ]	[ N ]	[    ]

RECOMMENDATIONS: (If different from NASA)

[    /    ]    [    ]    [    ]    [    ]    [    ]  
 (ADD/DELETE)

\* CIL RETENTION RATIONALE: (If applicable)

ADEQUATE [    ]  
 INADEQUATE [    ]

REMARKS:

ROCKWELL/NASA DID NOT COVER THIS FAILURE MODE.  
 THIS FAILURE MODE, "PREMATURE OPERATION TO LRU", IS DETERMINED TO  
 BE NON-CREDIBLE.

APPENDIX C  
ASSESSMENT WORKSHEET

ASSESSMENT DATE: 10/06/86  
 ASSESSMENT ID: DPS-146  
 NASA FMEA #: 05-5-B03-5-2

NASA DATA:  
 BASELINE [ X ]  
 NEW [ ]

SUBSYSTEM: DPS  
 MDAC ID: 146  
 ITEM: MDM PF1, PF2

LEAD ANALYST: W. A. Haufler

ASSESSMENT:

	CRITICALITY FLIGHT HDW/FUNC	REDUNDANCY SCREENS			CIL ITEM
		A	B	C	
NASA	[ 2 /1R ]	[ P ]	[ P ]	[ P ]	[ X ] *
IOA	[ 3 /1R ]	[ P ]	[ P ]	[ P ]	[ ]
COMPARE	[ N / ]	[ ]	[ ]	[ ]	[ N ]

RECOMMENDATIONS: (If different from NASA)

[ / ] [ ] [ ] [ ] [ ]  
 (ADD/DELETE)

\* CIL RETENTION RATIONALE: (If applicable)

ADEQUATE [ X ]  
 INADEQUATE [ ]

REMARKS:

IOA DID NOT INITIALLY CONSIDER INADVERTENT COMMAND TO PAYLOAD BAY  
 DOOR'S LATCH TO UNLATCH.  
 IOA DOES CONCUR WITH NASA'S REEVALUATION AND RATIONALE.  
 NO DIFFERENCES.



APPENDIX C  
ASSESSMENT WORKSHEET

ASSESSMENT DATE: 10/06/86  
 ASSESSMENT ID: DPS-147  
 NASA FMEA #: 05-5-B03-5-2

NASA DATA:  
 BASELINE [ X ]  
 NEW [ ]

SUBSYSTEM: DPS  
 MDAC ID: 147  
 ITEM: MDM PF1,PF2

LEAD ANALYST: W. A. Haufler

ASSESSMENT:

	CRITICALITY FLIGHT HDW/FUNC	REDUNDANCY SCREENS			CIL ITEM
		A	B	C	
NASA	[ 2 /1R ]	[ P ]	[ P ]	[ P ]	[ X ] *
IOA	[ 3 /1R ]	[ P ]	[ P ]	[ P ]	[ ]
COMPARE	[ N / ]	[ ]	[ ]	[ ]	[ N ]

RECOMMENDATIONS: (If different from NASA)

[ / ] [ ] [ ] [ ] [ ] (ADD/DELETE)

\* CIL RETENTION RATIONALE: (If applicable)

ADEQUATE [ X ]  
 INADEQUATE [ ]

REMARKS:

THIS FAILURE MODE "STUCK ON A CONSTANT OUTPUT TO LRU" IS CONSIDERED TO BE COVERED BY THIS ROCKWELL FMEA WITH FAILURE MODE "ERRONEOUS OUTPUT: ADDRESS CHECK FAILURE, DATA ERROR TO MDM MODULE, OR MODULE SELECT FAILURE".  
 IOA DID NOT INITIALLY CONSIDER INADVERTENT COMMAND TO PAYLOAD BAY DOOR'S LATCH TO UNLATCH.  
 IOA DOES CONCUR WITH NASA'S REEVALUATION AND RATIONALE.  
 NO DIFFERENCES.

APPENDIX C  
ASSESSMENT WORKSHEET

ASSESSMENT DATE: 10/06/86  
 ASSESSMENT ID: DPS-148  
 NASA FMEA #: 05-5-B03-5-1

NASA DATA:  
 BASELINE [ X ]  
 NEW [ ]

SUBSYSTEM: DPS  
 MDAC ID: 148  
 ITEM: MDM PF1,PF2

LEAD ANALYST: W. A. Haufler

ASSESSMENT:

	CRITICALITY	REDUNDANCY SCREENS			CIL
	FLIGHT HDW/FUNC	A	B	C	ITEM
NASA	[ 2 /1R ]	[ P ]	[ P ]	[ P ]	[ X ] *
IOA	[ 3 /1R ]	[ P ]	[ P ]	[ P ]	[ ]
COMPARE	[ N / ]	[ ]	[ ]	[ ]	[ N ]

RECOMMENDATIONS: (If different from NASA)

[ / ] [ ] [ ] [ ] [ ]  
 (ADD/DELETE)

\* CIL RETENTION RATIONALE: (If applicable)

ADEQUATE [ X ]  
 INADEQUATE [ ]

REMARKS:

THIS FAILURE MODE "FALSELY STUCK ON BUSY MODE" IS CONSIDERED TO BE COVERED BY THIS ROCKWELL FMEA WITH FAILURE MODE "NO OUTPUT: FAILED MDM PORT - SCU, MIA, A/D, POWER SUPPLIES, OR I/O CARD/CHANNEL FAILURE".

IOA DID NOT COVER THIS FAILURE MODE IN THE ORIGINAL ANALYSIS.

IOA DOES CONCUR WITH NASA'S REEVALUATION AND RATIONALE.

A SECOND MDM FAILURE WOULD REQUIRE EVA TO CLOSE PAYLOAD BAY DOORS FOR WORST CASE FAILURE MODE.

NO DIFFERENCES.

APPENDIX C  
ASSESSMENT WORKSHEET

ASSESSMENT DATE: 10/06/86  
 ASSESSMENT ID: DPS-180  
 NASA FMEA #: 05-5-B03-4-1

NASA DATA:  
 BASELINE [ X ]  
 NEW [ ]

SUBSYSTEM: DPS  
 MDAC ID: 180  
 ITEM: MDM LF1, LA1

LEAD ANALYST: W. A. Haufler

ASSESSMENT:

	CRITICALITY FLIGHT HDW/FUNC	REDUNDANCY SCREENS			CIL ITEM
		A	B	C	
NASA	[ 3 /2R ]	[ P ]	[ NA ]	[ P ]	[ ] *
IOA	[ 3 /2R ]	[ P ]	[ NA ]	[ P ]	[ ]
COMPARE	[ / ]	[ ]	[ ]	[ ]	[ ]

RECOMMENDATIONS: (If different from NASA)

[ / ] [ ] [ ] [ ] [ ] (ADD/DELETE)

\* CIL RETENTION RATIONALE: (If applicable)

ADEQUATE [ ]  
 INADEQUATE [ ]

REMARKS:  
 NO DIFFERENCES.

APPENDIX C  
ASSESSMENT WORKSHEET

ASSESSMENT DATE: 10/06/86  
 ASSESSMENT ID: DPS-181  
 NASA FMEA #: 05-5-B03-4-1

NASA DATA:  
 BASELINE [ X ]  
 NEW [ ]

SUBSYSTEM: DPS  
 MDAC ID: 181  
 ITEM: MDM LF1, LA1

LEAD ANALYST: W. A. Haufler

ASSESSMENT:

	CRITICALITY FLIGHT HDW/FUNC	REDUNDANCY SCREENS			CIL ITEM
		A	B	C	
NASA	[ 3 / 2R ]	[ P ]	[ NA ]	[ P ]	[ ] *
IOA	[ 3 / 2R ]	[ P ]	[ NA ]	[ P ]	[ ]
COMPARE	[ / ]	[ ]	[ ]	[ ]	[ ]

RECOMMENDATIONS: (If different from NASA)

[ / ] [ ] [ ] [ ] [ ]  
 (ADD/DELETE)

\* CIL RETENTION RATIONALE: (If applicable)

ADEQUATE [ ]  
 INADEQUATE [ ]

REMARKS:

THIS FAILURE MODE "LOSS OF OUTPUT TO LRU" IS CONSIDERED TO BE COVERED BY THIS ROCKWELL FMEA WITH FAILURE MODE "NO OUTPUT: FAILED MDM PORT - SCU, MIA, A/D, POWER SUPPLIES, OR I/O CARD/CHANNEL FAILURE".  
 NO DIFFERENCES.

APPENDIX C  
ASSESSMENT WORKSHEET

ASSESSMENT DATE: 10/06/86  
 ASSESSMENT ID: DPS-182  
 NASA FMEA #: 05-5-B03-4-2

NASA DATA:  
 BASELINE [ X ]  
 NEW [ ]

SUBSYSTEM: DPS  
 MDAC ID: 182  
 ITEM: MDM LF1, LA1

LEAD ANALYST: W. A. Haufler

ASSESSMENT:

	CRITICALITY FLIGHT HDW/FUNC	REDUNDANCY SCREENS			CIL ITEM
		A	B	C	
NASA	[ 3 / 2R ]	[ P ]	[ NA ]	[ P ]	[ ] *
IOA	[ 3 / 2R ]	[ P ]	[ NA ]	[ P ]	[ ]
COMPARE	[ / ]	[ ]	[ ]	[ ]	[ ]

RECOMMENDATIONS: (If different from NASA)

[ / ] [ ] [ ] [ ] [ ]  
 (ADD/DELETE)

\* CIL RETENTION RATIONALE: (If applicable)

ADEQUATE [ ]  
 INADEQUATE [ ]

REMARKS:  
 NO DIFFERENCES.

APPENDIX C  
ASSESSMENT WORKSHEET

ASSESSMENT DATE: 10/06/86  
 ASSESSMENT ID: DPS-183  
 NASA FMEA #: 05-5-B03-4-2

NASA DATA:  
 BASELINE [ X ]  
 NEW [ ]

SUBSYSTEM: DPS  
 MDAC ID: 183  
 ITEM: MDM LF1, LA1

LEAD ANALYST: W. A. Haufler

ASSESSMENT:

	CRITICALITY FLIGHT HDW/FUNC	REDUNDANCY SCREENS			CIL ITEM
		A	B	C	
NASA	[ 3 /2R ]	[ P ]	[ NA ]	[ P ]	[ ] *
IOA	[ 3 /2R ]	[ P ]	[ NA ]	[ P ]	[ ]
COMPARE	[ / ]	[ ]	[ ]	[ ]	[ ]
RECOMMENDATIONS:	(If different from NASA)				
	[ / ]	[ ]	[ ]	[ ]	[ ] (ADD/DELETE)

\* CIL RETENTION RATIONALE: (If applicable)

ADEQUATE [ ]  
 INADEQUATE [ ]

REMARKS:  
 THIS FAILURE MODE "ERRONEOUS OUTPUT TO LRU" IS CONSIDERED TO BE COVERED BY THIS ROCKWELL FMEA WITH FAILURE MODE "ERRONEOUS OUTPUT: OUTPUT CHANNEL".  
 NO DIFFERENCES.

APPENDIX C  
ASSESSMENT WORKSHEET

ASSESSMENT DATE: 10/06/86  
ASSESSMENT ID: DPS-184  
NASA FMEA #: NONE

NASA DATA:  
BASELINE [    ]  
NEW [    ]

SUBSYSTEM: DPS  
MDAC ID: 184  
ITEM: MDM LF1, LA1

LEAD ANALYST: W. A. Haufler

ASSESSMENT:

	CRITICALITY FLIGHT HDW/FUNC	REDUNDANCY SCREENS			CIL ITEM
		A	B	C	
NASA	[ / ]	[ ]	[ ]	[ ]	[ ] *
IOA	[ 3 /2R ]	[ P ]	[ NA ]	[ P ]	[ ]
COMPARE	[ N /N ]	[ N ]	[ N ]	[ N ]	[ ]

RECOMMENDATIONS: (If different from NASA)

[ / ] [ ] [ ] [ ] [ ]  
(ADD/DELETE)

\* CIL RETENTION RATIONALE: (If applicable)

ADEQUATE [    ]  
INADEQUATE [    ]

REMARKS:

ROCKWELL/NASA DID NOT COVER THIS FAILURE MODE.  
THIS FAILURE MODE, "PREMATURE OPERATION TO GPC", IS DETERMINED TO  
BE NON-CREDIBLE.

APPENDIX C  
ASSESSMENT WORKSHEET

ASSESSMENT DATE: 10/06/86  
ASSESSMENT ID: DPS-185  
NASA FMEA #: NONE

NASA DATA:  
BASELINE [    ]  
NEW [    ]

SUBSYSTEM: DPS  
MDAC ID: 185  
ITEM: MDM LF1, LA1

LEAD ANALYST: W. A. Haufler

ASSESSMENT:

	CRITICALITY FLIGHT HDW/FUNC	REDUNDANCY SCREENS			CIL ITEM
		A	B	C	
NASA	[    /    ]	[    ]	[    ]	[    ]	*
IOA	[ 3 / 2R ]	[ P ]	[ NA ]	[ P ]	
COMPARE	[ N / N ]	[ N ]	[ N ]	[ N ]	

RECOMMENDATIONS: (If different from NASA)

[    /    ]    [    ]    [    ]    [    ]    [    ]  
(ADD/DELETE)

\* CIL RETENTION RATIONALE: (If applicable)

ADEQUATE [    ]  
INADEQUATE [    ]

REMARKS:

ROCKWELL/NASA DID NOT COVER THIS FAILURE MODE.  
THIS FAILURE MODE, "PREMATURE OPERATION TO LRU", IS DETERMINED TO  
BE NON-CREDIBLE.



APPENDIX C  
ASSESSMENT WORKSHEET

ASSESSMENT DATE: 10/06/86  
 ASSESSMENT ID: DPS-186  
 NASA FMEA #: 05-5-B03-4-2

NASA DATA:  
 BASELINE [ X ]  
 NEW [ ]

SUBSYSTEM: DPS  
 MDAC ID: 186  
 ITEM: MDM LF1, LA1

LEAD ANALYST: W. A. Haufler

ASSESSMENT:

	CRITICALITY FLIGHT HDW/FUNC	REDUNDANCY SCREENS			CIL ITEM
		A	B	C	
NASA	[ 3 /2R ]	[ P ]	[ NA ]	[ P ]	[ ] *
IOA	[ 3 /2R ]	[ P ]	[ NA ]	[ P ]	[ ]
COMPARE	[ / ]	[ ]	[ ]	[ ]	[ ]

RECOMMENDATIONS: (If different from NASA)

[ / ] [ ] [ ] [ ] [ ]  
 (ADD/DELETE)

\* CIL RETENTION RATIONALE: (If applicable)

ADEQUATE [ ]  
 INADEQUATE [ ]

REMARKS:  
 NO DIFFERENCES.

APPENDIX C  
ASSESSMENT WORKSHEET

ASSESSMENT DATE: 10/06/86  
 ASSESSMENT ID: DPS-187  
 NASA FMEA #: 05-5-B03-4-2

NASA DATA:  
 BASELINE [ X ]  
 NEW [ ]

SUBSYSTEM: DPS  
 MDAC ID: 187  
 ITEM: MDM LF1, LA1

LEAD ANALYST: W. A. Haufler

ASSESSMENT:

	CRITICALITY FLIGHT HDW/FUNC	REDUNDANCY SCREENS			CIL ITEM
		A	B	C	
NASA	[ 3 / 2R ]	[ P ]	[ NA ]	[ P ]	[ ] *
IOA	[ 3 / 2R ]	[ P ]	[ NA ]	[ P ]	[ ]
COMPARE	[ / ]	[ ]	[ ]	[ ]	[ ]

RECOMMENDATIONS: (If different from NASA)

[ / ] [ ] [ ] [ ] [ ]  
 (ADD/DELETE)

\* CIL RETENTION RATIONALE: (If applicable)

ADEQUATE [ ]  
 INADEQUATE [ ]

REMARKS:

THIS FAILURE MODE "STUCK ON A CONSTANT OUTPUT" IS CONSIDERED TO BE COVERED BY THIS ROCKWELL FMEA WITH FAILURE MODE "ERRONEOUS OUTPUT: OUTPUT CHANNEL".  
 NO DIFFERENCES.

APPENDIX C  
ASSESSMENT WORKSHEET

ASSESSMENT DATE: 10/06/86  
 ASSESSMENT ID: DPS-188  
 NASA FMEA #: 05-5-B03-4-1

NASA DATA:  
 BASELINE [ X ]  
 NEW [ ]

SUBSYSTEM: DPS  
 MDAC ID: 188  
 ITEM: MDM LF1, LA1

LEAD ANALYST: W. A. Haufler

ASSESSMENT:

	CRITICALITY FLIGHT HDW/FUNC	REDUNDANCY SCREENS			CIL ITEM
		A	B	C	
NASA	[ 3 /2R ]	[ P ]	[ NA ]	[ P ]	[ ] *
IOA	[ 3 /2R ]	[ P ]	[ NA ]	[ P ]	[ ]
COMPARE	[ / ]	[ ]	[ ]	[ ]	[ ]

RECOMMENDATIONS: (If different from NASA)

[ / ] [ ] [ ] [ ] [ ]  
 (ADD/DELETE)

\* CIL RETENTION RATIONALE: (If applicable)

ADEQUATE [ ]  
 INADEQUATE [ ]

REMARKS:

THIS FAILURE MODE "FALSELY STUCK ON BUSY MODE" IS CONSIDERED TO BE COVERED BY THIS ROCKWELL FMEA WITH FAILURE MODE "NO OUTPUT: MDM FAILED PORT - SCU, A/D, MIA, POWER SUPPLY, OR I/O CHANNEL". NO DIFFERENCES.

APPENDIX C  
ASSESSMENT WORKSHEET

ASSESSMENT DATE: 10/15/86  
 ASSESSMENT ID: DPS-190  
 NASA FMEA #: 05-6S-BRES3-1

NASA DATA:  
 BASELINE [ ]  
 NEW [ X ]

SUBSYSTEM: DPS  
 MDAC ID: 190  
 ITEM: RESISTOR, CURRENT LIMITING

LEAD ANALYST: W. A. HAUFLE

ASSESSMENT:

	CRITICALITY FLIGHT HDW/FUNC	REDUNDANCY SCREENS			CIL ITEM
		A	B	C	
NASA	[ 3 /1R ]	[ P ]	[ F ]	[ P ]	[ X ] *
IOA	[ 3 /1R ]	[ P ]	[ F ]	[ P ]	[ ]
COMPARE	[ / ]	[ ]	[ ]	[ ]	[ N ]

RECOMMENDATIONS: (If different from NASA)

[ / ] [ ] [ ] [ ] [ ] (ADD/DELETE)

\* CIL RETENTION RATIONALE: (If applicable)

ADEQUATE [ ]  
 INADEQUATE [ X ]

REMARKS:

THE IOA DID NOT COVER THIS ITEM IN THE ORIGINAL ANALYSIS.  
 THE IOA DOES CONCUR WITH NASA'S REEVALUATION.  
 THE CIL RETENTION RATIONALE IS INADEQUATE BECAUSE IT IS NOT YET AVAILABLE.

APPENDIX C  
ASSESSMENT WORKSHEET

ASSESSMENT DATE: 10/15/86  
 ASSESSMENT ID: DPS-191  
 NASA FMEA #: 05-6S-BRPC3-1

NASA DATA:  
 BASELINE [    ]  
 NEW [ X ]

SUBSYSTEM: DPS  
 MDAC ID: 191  
 ITEM: CONTROLLER, REMOTE POWER

LEAD ANALYST: W. A. HAUFLER

ASSESSMENT:

	CRITICALITY FLIGHT HDW/FUNC	REDUNDANCY SCREENS			CIL ITEM
		A	B	C	
NASA	[ 3 /1R ]	[ P ]	[ F ]	[ P ]	[ X ] *
IOA	[ 3 /1R ]	[ P ]	[ F ]	[ P ]	[ X ]
COMPARE	[ / ]	[ ]	[ ]	[ ]	[ ]

RECOMMENDATIONS: (If different from NASA)

[ / ] [ ] [ ] [ ] [ ] (ADD/DELETE)

\* CIL RETENTION RATIONALE: (If applicable)

ADEQUATE [    ]  
 INADEQUATE [ X ]

REMARKS:

THE IOA DID NOT COVER THIS ITEM IN THE ORIGINAL ANALYSIS.  
 THE IOA DOES CONCUR WITH NASA'S REEVALUATION.  
 THE CIL RETENTION RATIONALE IS INADEQUATE BECAUSE IT IS NOT YET AVAILABLE.

APPENDIX C  
ASSESSMENT WORKSHEET

ASSESSMENT DATE: 10/15/86  
 ASSESSMENT ID: DPS-192  
 NASA FMEA #: 05-6S-BRPC3-2

NASA DATA:  
 BASELINE [ X ]  
 NEW [ ]

SUBSYSTEM: DPS  
 MDAC ID: 192  
 ITEM: CONTROLLER, REMOTE POWER

LEAD ANALYST: W. A. HAUFLER

ASSESSMENT:

	CRITICALITY FLIGHT HDW/FUNC	REDUNDANCY SCREENS			CIL ITEM
		A	B	C	
NASA	[ 3 / 3 ]	[ P ]	[ NA ]	[ P ]	[ ] *
IOA	[ 3 / 3 ]	[ NA ]	[ NA ]	[ NA ]	[ ]
COMPARE	[ / ]	[ N ]	[ ]	[ N ]	[ ]

RECOMMENDATIONS: (If different from NASA)

[ / ] [ ] [ ] [ ] [ ]  
 (ADD/DELETE)

\* CIL RETENTION RATIONALE: (If applicable)

ADEQUATE [ ]  
 INADEQUATE [ ]

REMARKS:

THE IOA DID NOT COVER THIS ITEM IN THE ORIGINAL ANALYSIS.  
 THE IOA DOES CONCUR WITH NASA'S REEVALUATION.  
 ACCORDING TO NSTS 22206, REDUNDANCY SCREENS MUST BE "NA" OR BLANK  
 FOR FMEAS WITH A CRITICALITY OF 3/3.

APPENDIX C  
ASSESSMENT WORKSHEET

ASSESSMENT DATE: 10/15/86  
 ASSESSMENT ID: DPS-193  
 NASA FMEA #: 05-6S-BSW3-1

NASA DATA:  
 BASELINE [ ]  
 NEW [ X ]

SUBSYSTEM: DPS  
 MDAC ID: 193  
 ITEM: SWITCH, MDM POWER

LEAD ANALYST: W. A. HAUFLE

ASSESSMENT:

	CRITICALITY FLIGHT HDW/FUNC	REDUNDANCY SCREENS			CIL ITEM
		A	B	C	
NASA	[ 3 /1R ]	[ P ]	[ F ]	[ P ]	[ X ] *
IOA	[ 3 /1R ]	[ P ]	[ F ]	[ P ]	[ X ]
COMPARE	[ / ]	[ ]	[ ]	[ ]	[ ]

RECOMMENDATIONS: (If different from NASA)

[ / ] [ ] [ ] [ ] [ ] (ADD/DELETE)

\* CIL RETENTION RATIONALE: (If applicable)

ADEQUATE [ ]  
 INADEQUATE [ X ]

REMARKS:

THE IOA DID NOT COVER THIS ITEM IN THE ORIGINAL ANALYSIS.  
 THE IOA DOES CONCUR WITH NASA'S REEVALUATION.  
 THE CIL RETENTION RATIONALE IS INADEQUATE BECAUSE IT IS NOT YET AVAILABLE.

APPENDIX C  
ASSESSMENT WORKSHEET

ASSESSMENT DATE: 10/15/86  
 ASSESSMENT ID: DPS-194  
 NASA FMEA #: 05-6S-BSW3-2

NASA DATA:  
 BASELINE [    ]  
 NEW [ X ]

SUBSYSTEM: DPS  
 MDAC ID: 194  
 ITEM: SWITCH, MDM POWER

LEAD ANALYST: W. A. HAUFLER

ASSESSMENT:

	CRITICALITY	REDUNDANCY SCREENS			CIL
	FLIGHT HDW/FUNC	A	B	C	ITEM
NASA	[ 3 / 3 ]	[ P ]	[ NA ]	[ P ]	[    ] *
IOA	[ 3 / 3 ]	[ NA ]	[ NA ]	[ NA ]	[    ]
COMPARE	[    /    ]	[ N ]	[    ]	[ N ]	[    ]

RECOMMENDATIONS: (If different from NASA)

[    /    ]    [    ]    [    ]    [    ]    [    ]  
 (ADD/DELETE)

\* CIL RETENTION RATIONALE: (If applicable)

ADEQUATE [    ]  
 INADEQUATE [    ]

REMARKS:

THE IOA DID NOT COVER THIS ITEM IN THE ORIGINAL ANALYSIS.  
 ACCORDING TO NSTS 22206, REDUNDANCY SCREENS MUST BE "NA" OR BLANK  
 FOR FMEAS WITH A CRITICALITY OF 3/3.  
 NASA AGREED WITH THE IOA ASSESSMENT RECOMMENDATION.



APPENDIX C  
ASSESSMENT WORKSHEET

ASSESSMENT DATE: 10/15/86  
 ASSESSMENT ID: DPS-195  
 NASA FMEA #: 05-6S-BSW5-3

NASA DATA:  
 BASELINE [    ]  
 NEW [ X ]

SUBSYSTEM: DPS  
 MDAC ID: 195  
 ITEM: SWITCH, MDM POWER

LEAD ANALYST: W. A. HAUFLER

ASSESSMENT:

	CRITICALITY FLIGHT HDW/FUNC	REDUNDANCY SCREENS			CIL ITEM
		A	B	C	
NASA	[ 3 /1R ]	[ P ]	[ F ]	[ P ]	[ X ] *
IOA	[ 3 /1R ]	[ P ]	[ F ]	[ P ]	[    ]
COMPARE	[ / ]	[    ]	[    ]	[    ]	[ N ]

RECOMMENDATIONS: (If different from NASA)

[ / ] [    ] [    ] [    ] [    ]  
 (ADD/DELETE)

\* CIL RETENTION RATIONALE: (If applicable)

ADEQUATE [    ]  
 INADEQUATE [ X ]

REMARKS:

THE IOA DID NOT COVER THIS ITEM IN THE ORIGINAL ANALYSIS.  
 THE IOA DOES CONCUR WITH NASA'S REEVALUATION.  
 THE CIL RETENTION RATIONALE IS INADEQUATE BECAUSE IT IS NOT YET  
 AVAILABLE.

APPENDIX C  
ASSESSMENT WORKSHEET

ASSESSMENT DATE: 10/06/86  
 ASSESSMENT ID: DPS-201  
 NASA FMEA #: 05-5-B02-1-1

NASA DATA:  
 BASELINE [ X ]  
 NEW [ ]

SUBSYSTEM: DPS  
 MDAC ID: 201  
 ITEM: Input/Output Processor (IOP)

LEAD ANALYST: T. B. Cribbs

ASSESSMENT:

	CRITICALITY FLIGHT HDW/FUNC	REDUNDANCY SCREENS			CIL ITEM
		A	B	C	
NASA	[ 2 /1R ]	[ P ]	[ P ]	[ P ]	[ X ] *
IOA	[ 3 /1R ]	[ P ]	[ P ]	[ P ]	[ ]
COMPARE	[ N / ]	[ ]	[ ]	[ ]	[ N ]

RECOMMENDATIONS: (If different from NASA)

[ / ] [ ] [ ] [ ] [ ]  
 (ADD/DELETE)

\* CIL RETENTION RATIONALE: (If applicable)

ADEQUATE [ X ]  
 INADEQUATE [ ]

REMARKS:

SIMULTANEOUS DISSIMILAR FAILURES WERE EXCLUDED FROM THE IOA.  
 MULTIPLE FAILURES ARE INCONSISTENT WITH THE NSTS 22206.  
 NASA'S FAILURE EFFECTS COUPLED THIS FAILURE WITH AN UNDETECTED  
 FLIGHT CONTROL SYSTEM FAILURE. THIS COULD RESULT IN TWO HEALTHY  
 PATHS BEING VOTED OUT. THIS COULD POSSIBLY CAUSE LOSS OF  
 VEHICLE.  
 IOA RECOMMENDS CHANGING THE EFFECTS TO DELETE THE SENTENCE  
 "DURING ASCENT/ENTRY, THIS...".  
 IOA DOES CONCUR WITH THE REST OF NASA'S REEVALUATION AND  
 RATIONALE.

APPENDIX C  
ASSESSMENT WORKSHEET

ASSESSMENT DATE: 10/06/86  
 ASSESSMENT ID: DPS-202  
 NASA FMEA #: 05-5-B02-1-2

NASA DATA:  
 BASELINE [ X ]  
 NEW [ ]

SUBSYSTEM: DPS  
 MDAC ID: 202  
 ITEM: Input/Output Processor (IOP)

LEAD ANALYST: T. B. Cribbs

ASSESSMENT:

	CRITICALITY FLIGHT HDW/FUNC	REDUNDANCY SCREENS			CIL ITEM
		A	B	C	
NASA	[ 3 /1R ]	[ P ]	[ P ]	[ P ]	[ ] *
IOA	[ 3 /1R ]	[ P ]	[ P ]	[ P ]	[ ]
COMPARE	[ / ]	[ ]	[ ]	[ ]	[ ]

RECOMMENDATIONS: (If different from NASA)

[ / ] [ ] [ ] [ ] [ ]  
 (ADD/DELETE)

\* CIL RETENTION RATIONALE: (If applicable)

ADEQUATE [ ]  
 INADEQUATE [ ]

REMARKS:

NO DIFFERENCES IN ANALYSIS RESULTS.

APPENDIX C  
ASSESSMENT WORKSHEET

ASSESSMENT DATE: 10/06/86  
 ASSESSMENT ID: DPS-203  
 NASA FMEA #: NONE

NASA DATA:  
 BASELINE [ ]  
 NEW [ ]

SUBSYSTEM: DPS  
 MDAC ID: 203  
 ITEM: Input/Output Processor (IOP)

LEAD ANALYST: T. B. Cribbs

ASSESSMENT:

	CRITICALITY FLIGHT HDW/FUNC	REDUNDANCY SCREENS			CIL ITEM
		A	B	C	
NASA	[ / ]	[ ]	[ ]	[ ]	[ ] *
IOA	[ 3 / 1R ]	[ P ]	[ P ]	[ P ]	[ ]
COMPARE	[ N / N ]	[ N ]	[ N ]	[ N ]	[ ]

RECOMMENDATIONS: (If different from NASA)

[ / ] [ ] [ ] [ ] [ ]  
 (ADD/DELETE)

\* CIL RETENTION RATIONALE: (If applicable)

ADEQUATE [ ]  
 INADEQUATE [ ]

REMARKS:

NASA/RI DID NOT COVER THIS FAILURE MODE OF PREMATURE OPERATION.  
 THE FAILURE MODE AND EFFECTS ARE DETERMINED TO BE NON-CREDIBLE.

APPENDIX C  
ASSESSMENT WORKSHEET

ASSESSMENT DATE: 10/06/86  
 ASSESSMENT ID: DPS-204  
 NASA FMEA #: 05-5-B02-1-2

NASA DATA:  
 BASELINE [ X ]  
 NEW [ ]

SUBSYSTEM: DPS  
 MDAC ID: 204  
 ITEM: Input/Output Processor (IOP)

LEAD ANALYST: T. B. Cribbs

ASSESSMENT:

	CRITICALITY FLIGHT HDW/FUNC	REDUNDANCY SCREENS			CIL ITEM
		A	B	C	
NASA	[ 3 /1R ]	[ P ]	[ P ]	[ P ]	[ ] *
IOA	[ 3 /1R ]	[ P ]	[ P ]	[ P ]	[ ]
COMPARE	[ / ]	[ ]	[ ]	[ ]	[ ]

RECOMMENDATIONS: (If different from NASA)

[ / ] [ ] [ ] [ ] [ ]  
 (ADD/DELETE)

\* CIL RETENTION RATIONALE: (If applicable)

ADEQUATE [ ]  
 INADEQUATE [ ]

REMARKS:

NO DIFFERENCE. FAILURE MODE'S EFFECT COULD HAVE BEEN CONSIDERED IN ROCKWELL'S 05-5 -B02-1-2. IOA'S FAILURE MODE ANALYSIS DID NOT CHANGE CRITICALITY OF FUNCTION.

APPENDIX C  
ASSESSMENT WORKSHEET

ASSESSMENT DATE: 10/06/86  
 ASSESSMENT ID: DPS-205  
 NASA FMEA #: 05-5-B01-1-1

NASA DATA:  
 BASELINE [ X ]  
 NEW [ ]

SUBSYSTEM: DPS  
 MDAC ID: 205  
 ITEM: Central Processing Unit (CPU)

LEAD ANALYST: T. B. Cribbs

ASSESSMENT:

	CRITICALITY	REDUNDANCY SCREENS			CIL ITEM
	FLIGHT HDW/FUNC	A	B	C	
NASA	[ 2 /1R ]	[ P ]	[ P ]	[ P ]	[ X ] *
IOA	[ 3 /1R ]	[ P ]	[ P ]	[ P ]	[ ]
COMPARE	[ N / ]	[ ]	[ ]	[ ]	[ N ]

RECOMMENDATIONS: (If different from NASA)

[ / ] [ ] [ ] [ ] [ ] (ADD/DELETE)

\* CIL RETENTION RATIONALE: (If applicable)

ADEQUATE [ X ]  
 INADEQUATE [ ]

REMARKS:

SIMULTANEOUS DISSIMILAR FAILURES WERE EXCLUDED FROM THE IOA.  
 MULTIPLE FAILURES ARE INCONSISTENT WITH THE NSTS 22206.  
 NASA CONSIDERED ONE GPC AND ONE FCS FAILURE IN ASSIGNING THEIR  
 CRITICALITY FOR THIS FMEA.  
 THE IOA RECOMMENDS CHANGING THE EFFECTS TO DELETE THE SENTENCE  
 "DURING ASCENT/ENTRY, THIS...".  
 IOA DOES CONCUR WITH THE REST OF NASA'S REEVALUATION AND  
 RATIONALE.

APPENDIX C  
ASSESSMENT WORKSHEET

ASSESSMENT DATE: 10/06/86  
 ASSESSMENT ID: DPS-206  
 NASA FMEA #: 05-5-B01-1-2

NASA DATA:  
 BASELINE [ X ]  
 NEW [ ]

SUBSYSTEM: DPS  
 MDAC ID: 206  
 ITEM: Central Processing Unit (CPU)

LEAD ANALYST: T. B. Cribbs

ASSESSMENT:

	CRITICALITY FLIGHT HDW/FUNC	REDUNDANCY SCREENS			CIL ITEM
		A	B	C	
NASA	[ 3 /1R ]	[ P ]	[ P ]	[ P ]	[ ] *
IOA	[ 3 /1R ]	[ P ]	[ P ]	[ P ]	[ ]
COMPARE	[ / ]	[ ]	[ ]	[ ]	[ ]

RECOMMENDATIONS: (If different from NASA)

[ / ] [ ] [ ] [ ] [ ]  
 (ADD/DELETE)

\* CIL RETENTION RATIONALE: (If applicable)

ADEQUATE [ ]  
 INADEQUATE [ ]

REMARKS:  
 NO DIFFERENCES

APPENDIX C  
ASSESSMENT WORKSHEET

ASSESSMENT DATE: 10/06/86  
 ASSESSMENT ID: DPS-207  
 NASA FMEA #: NONE

NASA DATA:  
 BASELINE [    ]  
 NEW [    ]

SUBSYSTEM: DPS  
 MDAC ID: 207  
 ITEM: Central Processing Unit (CPU)

LEAD ANALYST: T. B. Cribbs

ASSESSMENT:

	CRITICALITY FLIGHT HDW/FUNC	REDUNDANCY SCREENS			CIL ITEM
		A	B	C	
NASA	[    /    ]	[    ]	[    ]	[    ]	[    ] *
IOA	[ 3 / 1R ]	[ P ]	[ P ]	[ P ]	[    ]
COMPARE	[ N / N ]	[ N ]	[ N ]	[ N ]	[    ]

RECOMMENDATIONS: (If different from NASA)

[    /    ]    [    ]    [    ]    [    ]    [    ]  
 (ADD/DELETE)

\* CIL RETENTION RATIONALE: (If applicable)

ADEQUATE [    ]  
 INADEQUATE [    ]

REMARKS:

IOA DOES CONCUR WITH NASA'S REEVALUATION.  
 THE IOA DOES NOT RECOMMEND THAT A NEW FMEA BE WRITTEN, SINCE THE  
 CRITICALITY OF THIS ITEM WAS NOT INCREASED BY THE FAILURE MODE.



APPENDIX C  
ASSESSMENT WORKSHEET

ASSESSMENT DATE: 10/06/86  
 ASSESSMENT ID: DPS-208  
 NASA FMEA #: NONE

NASA DATA:  
 BASELINE [ X ]  
 NEW [ ]

SUBSYSTEM: DPS  
 MDAC ID: 208  
 ITEM: Central Processing Unit (CPU)

LEAD ANALYST: T. B. Cribbs

ASSESSMENT:

	CRITICALITY FLIGHT HDW/FUNC	REDUNDANCY SCREENS			CIL ITEM
		A	B	C	
NASA	[ / ]	[ ]	[ ]	[ ]	[ ] *
IOA	[ 2 / 1R ]	[ P ]	[ P ]	[ P ]	[ ]
COMPARE	[ N / N ]	[ N ]	[ N ]	[ N ]	[ ]

RECOMMENDATIONS: (If different from NASA)

[ / ] [ ] [ ] [ ] [ ]  
 (ADD/DELETE)

\* CIL RETENTION RATIONALE: (If applicable)

ADEQUATE [ ]  
 INADEQUATE [ ]

REMARKS:

THE FAILURE MODE AND EFFECTS ARE DETERMINED TO BE NON-CREDIBLE.

APPENDIX C  
ASSESSMENT WORKSHEET

ASSESSMENT DATE: 10/06/86  
 ASSESSMENT ID: DPS-209  
 NASA FMEA #: NONE

NASA DATA:  
 BASELINE [    ]  
 NEW [    ]

SUBSYSTEM: DPS  
 MDAC ID: 209  
 ITEM: CPU Power Switch

LEAD ANALYST: T. B. Cribbs

ASSESSMENT:

	CRITICALITY		REDUNDANCY SCREENS			CIL ITEM
	FLIGHT	HDW/FUNC	A	B	C	
NASA	[    /    ]	[    ]	[    ]	[    ]	[    ]	[    ] *
IOA	[ 3 / 3 ]	[ NA ]	[ NA ]	[ NA ]	[ NA ]	[    ]
COMPARE	[ N / N ]	[ N ]	[ N ]	[ N ]	[ N ]	[    ]

RECOMMENDATIONS: (If different from NASA)

[    /    ]    [    ]    [    ]    [    ]    [    ]  
 (ADD/DELETE)

\* CIL RETENTION RATIONALE: (If applicable)

ADEQUATE [    ]  
 INADEQUATE [    ]

REMARKS:  
 THIS FAILURE MODE WOULD REQUIRE A SECOND FAILURE OF THE GPC BEFORE THE CRITICALITY OF THE POWER SWITCH COULD BE UPGRADED. SECOND FAILURES ARE NOT ANALYZED TO ESTABLISH FUNCTIONAL CRITICALITY.  
 THIS FAILURE MODE AND EFFECTS ARE DETERMINED TO BE NON-CREDIBLE.

APPENDIX C  
ASSESSMENT WORKSHEET

ASSESSMENT DATE: 10/06/86  
 ASSESSMENT ID: DPS-210  
 NASA FMEA #: 05-5-B17-1-1

NASA DATA:  
 BASELINE [ ]  
 NEW [ X ]

SUBSYSTEM: DPS  
 MDAC ID: 210  
 ITEM: GPC Mode Switch

LEAD ANALYST: T. B. Cribbs

ASSESSMENT:

	CRITICALITY FLIGHT HDW/FUNC	REDUNDANCY SCREENS			CIL ITEM
		A	B	C	
NASA	[ 2 /1R ]	[ P ]	[ P ]	[ P ]	[ X ] *
IOA	[ 3 /1R ]	[ P ]	[ P ]	[ P ]	[ ]
COMPARE	[ N / ]	[ ]	[ ]	[ ]	[ N ]

RECOMMENDATIONS: (If different from NASA)

[ / ] [ ] [ ] [ ] [ ]  
 (ADD/DELETE)

\* CIL RETENTION RATIONALE: (If applicable)

ADEQUATE [ ]  
 INADEQUATE [ X ]

REMARKS:

THE IOA DOES NOT RECOMMEND THAT A NEW FMEA BE WRITTEN, SINCE THE CRITICALITY OF THIS ITEM WAS NOT INCREASED BY THE FAILURE MODE. IOA DOES CONCUR WITH NASA'S REEVALUATION. THE CIL RETENTION RATIONALE IS INADEQUATE BECAUSE IT IS NOT YET AVAILABLE.

APPENDIX C  
ASSESSMENT WORKSHEET

ASSESSMENT DATE: 10/06/86  
 ASSESSMENT ID: DPS-211  
 NASA FMEA #: 05-5-B15-1-3

NASA DATA:  
 BASELINE [ X ]  
 NEW [ ]

SUBSYSTEM: DPS  
 MDAC ID: 211  
 ITEM: GPC Output Switch

LEAD ANALYST: T. B. Cribbs

ASSESSMENT:

	CRITICALITY	REDUNDANCY SCREENS			CIL
	FLIGHT HDW/FUNC	A	B	C	ITEM
NASA	[ 3 /1R ]	[ P ]	[ P ]	[ P ]	[ ] *
IOA	[ 3 /1R ]	[ P ]	[ P ]	[ P ]	[ ]
COMPARE	[ / ]	[ ]	[ ]	[ ]	[ ]

RECOMMENDATIONS: (If different from NASA)

[ / ] [ ] [ ] [ ] [ ]  
 (ADD/DELETE)

\* CIL RETENTION RATIONALE: (If applicable)

ADEQUATE [ ]  
 INADEQUATE [ ]

REMARKS:

THIS FAILURE MODE IS CONSIDERED TO BE COVERED BY ROCKWELL'S 05-5-B15-1-3 WHICH HAS THE SAME CRITICALITY AS THIS FAILURE MODE.

APPENDIX C  
ASSESSMENT WORKSHEET

ASSESSMENT DATE: NASA DATA:  
 ASSESSMENT ID: DPS-213 BASELINE [ ]  
 NASA FMEA #: NONE NEW [ ]

SUBSYSTEM: DPS  
 MDAC ID: 213  
 ITEM: GPC Power Switch

LEAD ANALYST: T. B. Cribbs

ASSESSMENT:

	CRITICALITY FLIGHT HDW/FUNC	REDUNDANCY SCREENS			CIL ITEM
		A	B	C	
NASA	[ / ]	[ ]	[ ]	[ ]	[ ] *
IOA	[ 3 /1R ]	[ P ]	[ P ]	[ P ]	[ ]
COMPARE	[ N /N ]	[ N ]	[ N ]	[ N ]	[ ]

RECOMMENDATIONS: (If different from NASA)

[ / ] [ ] [ ] [ ] [ ]  
 (ADD/DELETE)

\* CIL RETENTION RATIONALE: (If applicable)

ADEQUATE [ ]  
 INADEQUATE [ ]

REMARKS:

NASA/RI DID NOT COVER THIS FAILURE MODE. IOA DOES NOT RECOMMEND A FMEA BEING WRITTEN SINCE THE CRITICALITY OF THIS ITEM WAS NOT INCREASED BY THE FAILURE MODE.

APPENDIX C  
ASSESSMENT WORKSHEET

ASSESSMENT DATE: 10/16/86  
 ASSESSMENT ID: DPS-214  
 NASA FMEA #: 05-6S-BDMC1-2

NASA DATA:  
 BASELINE [ ]  
 NEW [ X ]

SUBSYSTEM: DPS  
 MDAC ID: 214  
 ITEM: DRIVER MODULE CONTROLLER

LEAD ANALYST: B. ROBB

ASSESSMENT:

	CRITICALITY	REDUNDANCY SCREENS			CIL
	FLIGHT HDW/FUNC	A	B	C	ITEM
NASA	[ 3 / 3 ]	[ P ]	[ P ]	[ P ]	[ ] *
IOA	[ 3 / 3 ]	[ NA ]	[ NA ]	[ NA ]	[ ]
COMPARE	[ / ]	[ N ]	[ N ]	[ N ]	[ ]

RECOMMENDATIONS: (If different from NASA)

[ / ] [ ] [ ] [ ] [ ]  
 (ADD/DELETE)

\* CIL RETENTION RATIONALE: (If applicable)

ADEQUATE [ ]  
 INADEQUATE [ ]

REMARKS:

IOA DID NOT COVER THIS ITEM IN ORIGINAL ANALYSIS. NO HARMFUL EFFECTS TO POWER UP A GPC. ROCKWELL SHOULD DOWNGRADE THE FMEA. NASA AGREED WITH THE IOA ASSESSMENT RECOMMENDATION. ACCORDING TO NSTS 22206, REDUNDANCY SCREENS MUST BE "NA" OR BLANK FOR FMEAS WITH A CRITICALITY OF 3/3.

APPENDIX C  
ASSESSMENT WORKSHEET

ASSESSMENT DATE: 10/16/86  
 ASSESSMENT ID: DPS-215  
 NASA FMEA #: 05-6S-BDMC1-1

NASA DATA:  
 BASELINE [ X ]  
 NEW [ ]

SUBSYSTEM: DPS  
 MDAC ID: 215  
 ITEM: DRIVER MODULE CONTROLLER

LEAD ANALYST: B. ROBB

ASSESSMENT:

	CRITICALITY FLIGHT HDW/FUNC	REDUNDANCY SCREENS			CIL ITEM
		A	B	C	
NASA	[ 3 / 1R ]	[ P ]	[ P ]	[ P ]	[ ] *
IOA	[ 3 / 1R ]	[ P ]	[ P ]	[ P ]	[ ]
COMPARE	[ / ]	[ ]	[ ]	[ ]	[ ]

RECOMMENDATIONS: (If different from NASA)

[ / ] [ ] [ ] [ ] [ ]  
 (ADD/DELETE)

\* CIL RETENTION RATIONALE: (if applicable)

ADEQUATE [ ]  
 INADEQUATE [ ]

REMARKS:

NO DIFFERENCES. IOA DID NOT COVER THIS ITEM IN ORIGINAL ANALYSIS. THE CRITICALITY OF THE FUNCTION WAS NOT INCREASED BY THE FAILURE OF THE HARDWARE ITEM.

0-2

APPENDIX C  
ASSESSMENT WORKSHEET

ASSESSMENT DATE: 10/17/86  
 ASSESSMENT ID: DPS-216  
 NASA FMEA #: 05-6S-BSW1-2

NASA DATA:  
 BASELINE [    ]  
 NEW [ X ]

SUBSYSTEM: DPS  
 MDAC ID: 216  
 ITEM: SWITCH, GPC POWER

LEAD ANALYST: B. ROBB

ASSESSMENT:

	CRITICALITY FLIGHT HDW/FUNC	REDUNDANCY SCREENS			CIL ITEM
		A	B	C	
NASA	[ 3 / 3 ]	[ P ]	[ P ]	[ P ]	[    ] *
IOA	[ 3 / 3 ]	[ NA ]	[ NA ]	[ NA ]	[    ]
COMPARE	[ / ]	[ N ]	[ N ]	[ N ]	[    ]

RECOMMENDATIONS: (If different from NASA)

[ / ] [ ] [ ] [ ] [    ]  
 (ADD/DELETE)

\* CIL RETENTION RATIONALE: (If applicable)

ADEQUATE [    ]  
 INADEQUATE [    ]

REMARKS:

IOA DID NOT COVER THIS FAILURE MODE IN THE ORIGINAL ANALYSIS.  
 THE FAILURE MODE OF PREMATURE OPERATION CAUSES NO HARMFUL  
 EFFECTS. THE CRITICALITY OF THE ROCKWELL FMEA SHOULD BE  
 DOWNGRADED TO A 3/3.  
 NASA AGREED WITH THE IOA ASSESSMENT RECOMMENDATION.  
 ACCORDING TO NSTS 22206, REDUNDANCY SCREENS MUST BE "NA" OR BLANK  
 FOR FMEAS WITH A CRITICALITY OF 3/3.



APPENDIX C  
ASSESSMENT WORKSHEET

ASSESSMENT DATE: 10/17/86  
 ASSESSMENT ID: DPS-217  
 NASA FMEA #: 05-6S-BSW1-3 (NEW)

NASA DATA:  
 BASELINE [ ]  
 NEW [ X ]

SUBSYSTEM: DPS  
 MDAC ID: 217  
 ITEM: SWITCH, GPC POWER

LEAD ANALYST: B. ROBB

ASSESSMENT:

	CRITICALITY FLIGHT HDW/FUNC	REDUNDANCY SCREENS			CIL ITEM
		A	B	C	
NASA	[ 2 /1R ]	[ P ]	[ P ]	[ P ]	[ X ] *
IOA	[ 2 /1R ]	[ P ]	[ P ]	[ P ]	[ X ]
COMPARE	[ / ]	[ ]	[ ]	[ ]	[ ]

RECOMMENDATIONS: (If different from NASA)

[ / ] [ ] [ ] [ ] [ ]  
 (ADD/DELETE)

\* CIL RETENTION RATIONALE: (If applicable)

ADEQUATE [ ]  
 INADEQUATE [ X ]

REMARKS:

NO DIFFERENCES. THIS ITEM WAS PRESENTED AT THE DPS PRE-BOARD AS NEW FMEA. IOA DID NOT COVER THE FAILURE MODE IN THE ORIGINAL ANALYSIS.  
 THE CIL RETENTION RATIONALE IS INADEQUATE BECAUSE IT IS NOT YET AVAILABLE.  
 IOA AGREES THAT CRITICALITY SHOULD BE SAME AS LOSS OF GPC OUTPUT FOR THIS FAILURE MODE.

APPENDIX C  
ASSESSMENT WORKSHEET

ASSESSMENT DATE: 10/20/86  
 ASSESSMENT ID: DPS-218  
 NASA FMEA #: 05-5-B27-1-1

NASA DATA:  
 BASELINE [ X ]  
 NEW [ ]

SUBSYSTEM: DPS  
 MDAC ID: 218  
 ITEM: STATUS LIGHT

LEAD ANALYST: B. ROBB

ASSESSMENT:

	CRITICALITY FLIGHT HDW/FUNC	REDUNDANCY SCREENS			CIL ITEM
		A	B	C	
NASA	[ 3 / 3 ]	[ P ]	[ P ]	[ P ]	[ ] *
IOA	[ 3 / 3 ]	[ NA ]	[ NA ]	[ NA ]	[ ]
COMPARE	[ / ]	[ N ]	[ N ]	[ N ]	[ ]

RECOMMENDATIONS: (If different from NASA)

[ / ] [ ] [ ] [ ] [ ]  
 (ADD/DELETE)

\* CIL RETENTION RATIONALE: (If applicable)

ADEQUATE [ ]  
 INADEQUATE [ ]

REMARKS:

NO DIFFERENCES. IOA DID NOT COVER THIS ITEM IN THE ORIGINAL ANALYSIS.  
 ACCORDING TO NSTS 22206, REDUNDANCY SCREENS MUST BE "NA" OR BLANK FOR FMEAS WITH A CRITICALITY OF 3/3.

APPENDIX C  
ASSESSMENT WORKSHEET

ASSESSMENT DATE: 10/20/86  
 ASSESSMENT ID: DPS-219  
 NASA FMEA #: 05-5-B27-2-1

NASA DATA:  
 BASELINE [ X ]  
 NEW [ ]

SUBSYSTEM: DPS  
 MDAC ID: 219  
 ITEM: CICU

LEAD ANALYST: B. ROBB

ASSESSMENT:

	CRITICALITY	REDUNDANCY SCREENS			CIL
	FLIGHT HDW/FUNC	A	B	C	ITEM
NASA	[ 3 / 3 ]	[ P ]	[ P ]	[ P ]	[ ] *
IOA	[ 3 / 3 ]	[ NA ]	[ NA ]	[ NA ]	[ ]
COMPARE	[ / ]	[ N ]	[ N ]	[ N ]	[ ]

RECOMMENDATIONS: (If different from NASA)

[ / ] [ ] [ ] [ ] [ ] (ADD/DELETE)

\* CIL RETENTION RATIONALE: (If applicable)

ADEQUATE [ ]  
 INADEQUATE [ ]

REMARKS:

NO DIFFERENCES. IOA DID NOT COVER THIS ITEM IN ORIGINAL ANALYSIS.  
 ACCORDING TO NSTS 22206, REDUNDANCY SCREENS MUST BE "NA" OR BLANK FOR FMEAS WITH A CRITICALITY OF 3/3.

APPENDIX C  
ASSESSMENT WORKSHEET

ASSESSMENT DATE: 10/20/86  
 ASSESSMENT ID: DPS-220  
 NASA FMEA #: 05-5-B16-1-1

NASA DATA:  
 BASELINE [ X ]  
 NEW [ ]

SUBSYSTEM: DPS  
 MDAC ID: 220  
 ITEM: SWITCH, IPL

LEAD ANALYST: B. ROBB

ASSESSMENT:

	CRITICALITY FLIGHT HDW/FUNC	REDUNDANCY SCREENS			CIL ITEM
		A	B	C	
NASA	[ 3 /2R ]	[ P ]	[ P ]	[ P ]	[ ] *
IOA	[ 3 /2R ]	[ P ]	[ P ]	[ P ]	[ ]
COMPARE	[ / ]	[ ]	[ ]	[ ]	[ ]

RECOMMENDATIONS: (If different from NASA)

[ / ] [ ] [ ] [ ] [ ]  
 (ADD/DELETE)

\* CIL RETENTION RATIONALE: (If applicable)

ADEQUATE [ ]  
 INADEQUATE [ ]

REMARKS:

NO DIFFERENCES. IOA DID NOT COVER THIS ITEM IN THE ORIGINAL ANALYSIS.

APPENDIX C  
ASSESSMENT WORKSHEET

ASSESSMENT DATE: 10/20/86  
 ASSESSMENT ID: DPS-221  
 NASA FMEA #: 05-5-B18-1-1

NASA DATA:  
 BASELINE [ X ]  
 NEW [ ]

SUBSYSTEM: DPS  
 MDAC ID: 221  
 ITEM: INDICATOR, IPL

LEAD ANALYST: B. ROBB

ASSESSMENT:

	CRITICALITY FLIGHT HDW/FUNC	REDUNDANCY SCREENS			CIL ITEM
		A	B	C	
NASA	[ 3 / 3 ]	[ P ]	[ P ]	[ P ]	[ ] *
IOA	[ 3 / 3 ]	[ NA ]	[ NA ]	[ NA ]	[ ]
COMPARE	[ / ]	[ N ]	[ N ]	[ N ]	[ ]

RECOMMENDATIONS: (If different from NASA)

[ / ] [ ] [ ] [ ] [ ] (ADD/DELETE)

\* CIL RETENTION RATIONALE: (If applicable)

ADEQUATE [ ]  
 INADEQUATE [ ]

REMARKS:

NO DIFFERENCES. IOA DID NOT COVER THIS ITEM IN THE ORIGINAL ANALYSIS.  
 ACCORDING TO NSTS 22206, REDUNDANCY SCREENS MUST BE "NA" OR BLANK FOR FMEAS WITH A CRITICALITY OF 3/3.

APPENDIX C  
ASSESSMENT WORKSHEET

ASSESSMENT DATE: 10/20/86  
 ASSESSMENT ID: DPS-222  
 NASA FMEA #: 05-5-B18-1-2

NASA DATA:  
 BASELINE [ X ]  
 NEW [ ]

SUBSYSTEM: DPS  
 MDAC ID: 222  
 ITEM: INDICATOR, IPL

LEAD ANALYST: B. ROBB

ASSESSMENT:

	CRITICALITY	REDUNDANCY SCREENS			CIL
	FLIGHT HDW/FUNC	A	B	C	ITEM
NASA	[ 3 / 3 ]	[ P ]	[ P ]	[ P ]	[ ] *
IOA	[ 3 / 3 ]	[ NA ]	[ NA ]	[ NA ]	[ ]
COMPARE	[ / ]	[ N ]	[ N ]	[ N ]	[ ]

RECOMMENDATIONS: (If different from NASA)

[ / ] [ ] [ ] [ ] [ ]  
 (ADD/DELETE)

\* CIL RETENTION RATIONALE: (If applicable)

ADEQUATE [ ]  
 INADEQUATE [ ]

REMARKS:

NO DIFFERENCES. IOA DID NOT COVER THIS ITEM IN THE ORIGINAL ANALYSIS.  
 ACCORDING TO NSTS 22206, REDUNDANCY SCREENS MUST BE "NA" OR BLANK FOR FMEAS WITH A CRITICALITY OF 3/3.

APPENDIX C  
ASSESSMENT WORKSHEET

ASSESSMENT DATE: 10/20/86  
 ASSESSMENT ID: DPS-223  
 NASA FMEA #: 05-5-B19-1-1

NASA DATA:  
 BASELINE [ X ]  
 NEW [ ]

SUBSYSTEM: DPS  
 MDAC ID: 223  
 ITEM: INDICATOR OUTPUT, BARBER POLE

LEAD ANALYST: B. ROBB

ASSESSMENT:

	CRITICALITY FLIGHT HDW/FUNC	REDUNDANCY SCREENS			CIL ITEM
		A	B	C	
NASA	[ 3 / 3 ]	[ P ]	[ P ]	[ P ]	[ ] *
IOA	[ 3 / 3 ]	[ NA ]	[ NA ]	[ NA ]	[ ]
COMPARE	[ - / ]	[ N ]	[ N ]	[ N ]	[ ]

RECOMMENDATIONS: (If different from NASA)

[ / ] [ ] [ ] [ ] [ ] (ADD/DELETE)

\* CIL RETENTION RATIONALE: (If applicable)

ADEQUATE [ ]  
 INADEQUATE [ ]

REMARKS:

NO DIFFERENCES. IOA DID NOT COVER THIS ITEM IN THE ORIGINAL ANALYSIS.  
 ACCORDING TO NSTS 22206, REDUNDANCY SCREENS MUST BE "NA" OR BLANK FOR FMEAS WITH A CRITICALITY OF 3/3.

APPENDIX C  
ASSESSMENT WORKSHEET

ASSESSMENT DATE: 10/20/86  
ASSESSMENT ID: DPS-224  
NASA FMEA #: 05-5-B19-1-2

NASA DATA:  
BASELINE [ X ]  
NEW [ ]

SUBSYSTEM: DPS  
MDAC ID: 224  
ITEM: INDICATOR OUTPUT, BARBER POLE

LEAD ANALYST: B. ROBB

ASSESSMENT:

	CRITICALITY			REDUNDANCY SCREENS			CIL ITEM
	FLIGHT			A	B	C	
	HDW/FUNC						
NASA	[ 3 / 3 ]			[ P ]	[ P ]	[ P ]	[ ] *
IOA	[ 3 / 3 ]			[ NA ]	[ NA ]	[ NA ]	[ ]
COMPARE	[ / ]			[ N ]	[ N ]	[ N ]	[ ]

RECOMMENDATIONS: (If different from NASA)

[ / ] [ ] [ ] [ ] [ ]  
(ADD/DELETE)

\* CIL RETENTION RATIONALE: (If applicable)

ADEQUATE [ ]  
INADEQUATE [ ]

REMARKS:

NO DIFFERENCES. IOA DID NOT COVER THIS ITEM IN THE ORIGINAL ANALYSIS.  
ACCORDING TO NSTS 22206, REDUNDANCY SCREENS MUST BE "NA" OR BLANK FOR FMEAS WITH A CRITICALITY OF 3/3.



APPENDIX C  
ASSESSMENT WORKSHEET

ASSESSMENT DATE: 10/27/86  
 ASSESSMENT ID: DPS-225  
 NASA FMEA #: 05-5-B02-1-3

NASA DATA:  
 BASELINE [ X ]  
 NEW [ ]

SUBSYSTEM: DPS  
 MDAC ID: 225  
 ITEM: INPUT/OUTPUT PROCESSOR (IOP)

LEAD ANALYST: B. ROBB

ASSESSMENT:

	CRITICALITY FLIGHT HDW/FUNC	REDUNDANCY SCREENS			CIL ITEM
		A	B	C	
NASA	[ 2 /1R ]	[ P ]	[ P ]	[ P ]	[ X ] *
IOA	[ 2 /1R ]	[ P ]	[ P ]	[ P ]	[ X ]
COMPARE	[ / ]	[ ]	[ ]	[ ]	[ ]

RECOMMENDATIONS: (If different from NASA)

[ / ] [ ] [ ] [ ] [ ]  
 (ADD/DELETE)

\* CIL RETENTION RATIONALE: (If applicable)

ADEQUATE [ X ]  
 INADEQUATE [ ]

REMARKS:

NO DIFFERENCES. IOA DID NOT COVER THIS FAILURE MODE IN ORIGINAL ANALYSIS.

APPENDIX C  
ASSESSMENT WORKSHEET

ASSESSMENT DATE: 10/30/86  
 ASSESSMENT ID: DPS-226  
 NASA FMEA #: 05-6S-BRES1-1

NASA DATA:  
 BASELINE [ ]  
 NEW [ X ]

SUBSYSTEM: DPS  
 MDAC ID: 226  
 ITEM: RESISTOR

LEAD ANALYST: H J LOWERY

ASSESSMENT:

	CRITICALITY FLIGHT HDW/FUNC	REDUNDANCY SCREENS			CIL ITEM
		A	B	C	
NASA	[ /NA ]	[ NA ]	[ NA ]	[ NA ]	[ ] *
IOA	[ /NA ]	[ NA ]	[ NA ]	[ NA ]	[ ]
COMPARE	[ / ]	[ ]	[ ]	[ ]	[ ]

RECOMMENDATIONS: (If different from NASA)

[ / ] [ ] [ ] [ ] [ ] (ADD/DELETE)

\* CIL RETENTION RATIONALE: (If applicable)

ADEQUATE [ ]  
 INADEQUATE [ ]

REMARKS:

FMEA HAS BEEN DELETED BECAUSE RESISTOR HAS BEEN REPLACED WITH A FUSE.  
 IOA DID NOT COVER THIS FAILURE MODE IN THE ORIGINAL ANALYSIS.

APPENDIX C  
ASSESSMENT WORKSHEET

ASSESSMENT DATE: 10/30/86  
 ASSESSMENT ID: DPS-227  
 NASA FMEA #: 05-6S-BFUS1-1

NASA DATA:  
 BASELINE [ X ]  
 NEW [ ]

SUBSYSTEM: DPS  
 MDAC ID: 227  
 ITEM: FUSE

LEAD ANALYST: H J LOWERY

ASSESSMENT:

	CRITICALITY FLIGHT HDW/FUNC	REDUNDANCY SCREENS			CIL ITEM
		A	B	C	
NASA	[ 3 /1R ]	[ P ]	[ P ]	[ P ]	[ ] *
IOA	[ 3 /1R ]	[ P ]	[ P ]	[ P ]	[ ]
COMPARE	[ / ]	[ ]	[ ]	[ ]	[ ]

RECOMMENDATIONS: (If different from NASA)

[ / ] [ ] [ ] [ ] [ ] (ADD/DELETE)

\* CIL RETENTION RATIONALE: (If applicable)

ADEQUATE [ ]  
 INADEQUATE [ ]

REMARKS:

NO DIFFERENCES. IOA DID NOT COVER THIS FAILURE MODE IN THE ORIGINAL ANALYSIS.

APPENDIX C  
ASSESSMENT WORKSHEET

ASSESSMENT DATE: 10/30/86  
 ASSESSMENT ID: DPS-228  
 NASA FMEA #: 05-6S-BRPC1-1

NASA DATA:  
 BASELINE [ X ]  
 NEW [ ]

SUBSYSTEM: DPS  
 MDAC ID: 228  
 ITEM: CONTROLLER, REMOTE POWER

LEAD ANALYST: H J LOWERY

ASSESSMENT:

	CRITICALITY FLIGHT HDW/FUNC	REDUNDANCY SCREENS			CIL ITEM
		A	B	C	
NASA	[ 3 /1R ]	[ P ]	[ P ]	[ P ]	[ ] *
IOA	[ 3 /1R ]	[ P ]	[ P ]	[ P ]	[ ]
COMPARE	[ / ]	[ ]	[ ]	[ ]	[ ]

RECOMMENDATIONS: (If different from NASA)

[ / ] [ ] [ ] [ ] [ ]  
 (ADD/DELETE)

\* CIL RETENTION RATIONALE: (If applicable)

ADEQUATE [ ]  
 INADEQUATE [ ]

REMARKS:  
 NO DIFFERENCES. IOA DID NOT COVER THIS FAILURE MODE IN THE ORIGINAL ANALYSIS.

APPENDIX C  
ASSESSMENT WORKSHEET

ASSESSMENT DATE: 10/30/86  
 ASSESSMENT ID: DPS-229  
 NASA FMEA #: 05-6S-BRPC1-2

NASA DATA:  
 BASELINE [ X ]  
 NEW [ ]

SUBSYSTEM: DPS  
 MDAC ID: 229  
 ITEM: CONTROLLER, REMOTE POWER

LEAD ANALYST: H J LOWERY

ASSESSMENT:

	CRITICALITY		REDUNDANCY SCREENS			CIL ITEM
	FLIGHT HDW/FUNC		A	B	C	
NASA	[ 3 / 3 ]		[ P ]	[ P ]	[ P ]	[ ] *
IOA	[ 3 / 3 ]		[ NA ]	[ NA ]	[ NA ]	[ ]
COMPARE	[ / ]		[ N ]	[ N ]	[ N ]	[ ]

RECOMMENDATIONS: (If different from NASA)

[ / ] [ ] [ ] [ ] [ ] (ADD/DELETE)

\* CIL RETENTION RATIONALE: (If applicable)

ADEQUATE [ ]  
 INADEQUATE [ ]

REMARKS:

NO DIFFERENCES. IOA DID NOT COVER THIS FAILURE MODE IN THE ORIGINAL ANALYSIS.  
 ACCORDING TO NSTS 22206, REDUNDANCY SCREENS MUST BE "NA" OR BLANK FOR FMEAS WITH A CRITICALITY OF 3/3.

APPENDIX C  
ASSESSMENT WORKSHEET

ASSESSMENT DATE: 11/03/86  
 ASSESSMENT ID: DPS-230  
 NASA FMEA #: 05-6S-BDIOX-1 (NEW)

NASA DATA:  
 BASELINE [ ]  
 NEW [ X ]

SUBSYSTEM: DPS  
 MDAC ID: 230  
 ITEM: DIODE

LEAD ANALYST: H J LOWERY

ASSESSMENT:

	CRITICALITY FLIGHT HDW/FUNC	REDUNDANCY SCREENS			CIL ITEM
		A	B	C	
NASA	[ 3 / 1R ]	[ P ]	[ F ]	[ P ]	[ X ] *
IOA	[ 3 / 1R ]	[ P ]	[ F ]	[ P ]	[ X ]
COMPARE	[ / ]	[ ]	[ ]	[ ]	[ ]

RECOMMENDATIONS: (If different from NASA)

[ / ] [ ] [ ] [ ] [ ]  
 (ADD/DELETE)

\* CIL RETENTION RATIONALE: (If applicable)

ADEQUATE [ ]  
 INADEQUATE [ X ]

REMARKS:

NO DIFFERENCES. IOA DID NOT COVER THIS FAILURE MODE IN THE ORIGINAL ANALYSIS.  
 THE CIL RETENTION RATIONALE IS INADEQUATE BECAUSE IT IS NOT YET AVAILABLE.  
 NASA AGREED WITH THE IOA ASSESSMENT RECOMMENDATION.

APPENDIX C  
ASSESSMENT WORKSHEET

ASSESSMENT DATE: 11/03/86  
 ASSESSMENT ID: DPS-231  
 NASA FMEA #: 05-5-B15-1-1

NASA DATA:  
 BASELINE [    ]  
 NEW [ X ]

SUBSYSTEM: DPS  
 MDAC ID: 231  
 ITEM: SWITCH, NORMAL-TERM BACK-UP

LEAD ANALYST: H J LOWERY

ASSESSMENT:

	CRITICALITY FLIGHT HDW/FUNC	REDUNDANCY SCREENS			CIL ITEM
		A	B	C	
NASA	[ 3 /1R ]	[ P ]	[ P ]	[ P ]	[    ] *
IOA	[ 3 /1R ]	[ P ]	[ P ]	[ P ]	[    ]
COMPARE	[ / ]	[    ]	[    ]	[    ]	[    ]

RECOMMENDATIONS: (If different from NASA)

[ / ] [    ] [    ] [    ] [    ]  
 (ADD/DELETE)

\* CIL RETENTION RATIONALE: (If applicable)

ADEQUATE [    ]  
 INADEQUATE [    ]

REMARKS:

NO DIFFERENCES. IOA DID NOT COVER THIS FAILURE MODE IN THE ORIGINAL ANALYSIS.

APPENDIX C  
ASSESSMENT WORKSHEET

ASSESSMENT DATE: 10/06/86  
 ASSESSMENT ID: DPS-232  
 NASA FMEA #: 05-6S-BSW1-1

NASA DATA:  
 BASELINE [ X ]  
 NEW [ ]

SUBSYSTEM: DPS  
 MDAC ID: 232  
 ITEM: SWITCH, GPC POWER

LEAD ANALYST: B. ROBB

ASSESSMENT:

	CRITICALITY FLIGHT HDW/FUNC	REDUNDANCY SCREENS			CIL ITEM
		A	B	C	
NASA	[ 3 /1R ]	[ P ]	[ P ]	[ P ]	[ ] *
IOA	[ 3 /1R ]	[ P ]	[ P ]	[ P ]	[ ]
COMPARE	[ / ]	[ ]	[ ]	[ ]	[ ]

RECOMMENDATIONS: (If different from NASA)

[ / ] [ ] [ ] [ ] [ ]  
 (ADD/DELETE)

\* CIL RETENTION RATIONALE: (If applicable)

ADEQUATE [ ]  
 INADEQUATE [ ]

REMARKS:

THIS FAILURE OF ONE SET OF CONTACTS ON THE POWER SWITCH HAS THE SAME EFFECT AS THE LOSS OF A DRIVER MODULE CONTROLLER. ONE OF THREE REDUNDANT POWER SOURCES IS LOST. NO DIFFERENCES. IOA DID NOT COVER THIS FAILURE MODE IN THE ORIGINAL ANALYSIS.



APPENDIX C  
ASSESSMENT WORKSHEET

ASSESSMENT DATE: 10/07/86  
 ASSESSMENT ID: DPS-300  
 NASA FMEA #: 05-5-B22-1-1

NASA DATA:  
 BASELINE [ X ]  
 NEW [ ]

SUBSYSTEM: DPS  
 MDAC ID: 300  
 ITEM: KEYBOARD SWITCH

LEAD ANALYST: H J LOWERY

ASSESSMENT:

	CRITICALITY FLIGHT HDW/FUNC	REDUNDANCY SCREENS			CIL ITEM
		A	B	C	
NASA	[ 2 /1R ]	[ P ]	[ P ]	[ P ]	[ X ] *
IOA	[ 3 /1R ]	[ P ]	[ P ]	[ P ]	[ ]
COMPARE	[ N / ]	[ ]	[ ]	[ ]	[ N ]

RECOMMENDATIONS: (If different from NASA)

[ / ] [ ] [ ] [ ] [ ] (ADD/DELETE)

\* CIL RETENTION RATIONALE: (If applicable)

ADEQUATE [ X ]  
 INADEQUATE [ ]

REMARKS:

REDUNDANT HARDWARE WOULD NOT BE ACCESSIBLE DURING LIFTOFF AND DEORBIT. KEYBOARD COMMAND CAPABILITY WOULD BE INHIBITED. THE SECOND RELATED FAILURE WOULD RESULT IN LOSS OF LIFE/VEHICLE. IOA DOES CONCUR WITH NASA'S REEVALUATION AND RATIONALE.

APPENDIX C  
ASSESSMENT WORKSHEET

ASSESSMENT DATE: 10/14/86  
 ASSESSMENT ID: DPS-300A  
 NASA FMEA #: 05-5-B24-1-2

NASA DATA:  
 BASELINE [ X ]  
 NEW [ ]

SUBSYSTEM: DPS  
 MDAC ID: 300  
 ITEM: KEYBOARD SWITCH

LEAD ANALYST: H J LOWERY

ASSESSMENT:

	CRITICALITY		REDUNDANCY SCREENS			CIL ITEM
	FLIGHT	HDW/FUNC	A	B	C	
NASA	[ 3 /2R ]		[ P ]	[ P ]	[ P ]	[ ] *
IOA	[ 3 /1R ]		[ P ]	[ P ]	[ P ]	[ ]
COMPARE	[ /N ]		[ ]	[ ]	[ ]	[ ]

RECOMMENDATIONS: (If different from NASA)

[ / ] [ ] [ ] [ ] [ ]  
 (ADD/DELETE)

\* CIL RETENTION RATIONALE: (If applicable)

ADEQUATE [ ]  
 INADEQUATE [ ]

REMARKS:

NO DIFFERENCES. THIS FAILURE MODE DID NOT UPGRADE THE FUNCTIONAL  
 CRITICALITY.  
 IOA DOES CONCUR WITH NASA'S REEVALUATION.

APPENDIX C  
ASSESSMENT WORKSHEET

ASSESSMENT DATE: 10/14/86  
 ASSESSMENT ID: DPS-300B  
 NASA FMEA #: 05-5-B24-1-1

NASA DATA:  
 BASELINE [    ]  
 NEW [ X ]

SUBSYSTEM: DPS  
 MDAC ID: 300  
 ITEM: KEYBOARD SWITCH

LEAD ANALYST: H J LOWERY

ASSESSMENT:

	CRITICALITY FLIGHT HDW/FUNC	REDUNDANCY SCREENS			CIL ITEM
		A	B	C	
NASA	[ 2 /1R ]	[ P ]	[ P ]	[ P ]	[ X ] *
IOA	[ 3 /1R ]	[ P ]	[ P ]	[ P ]	[    ]
COMPARE	[ N /    ]	[    ]	[    ]	[    ]	[ N ]

RECOMMENDATIONS: (If different from NASA)

[    /    ]    [    ]    [    ]    [    ]    [    ]  
 (ADD/DELETE)

\* CIL RETENTION RATIONALE: (If applicable)

ADEQUATE [    ]  
 INADEQUATE [ X ]

REMARKS:

IOA DOES CONCUR WITH NASA'S REEVALUATION.  
 THE CIL RETENTION RATIONALE IS INADEQUATE BECAUSE IT IS NOT YET  
 AVAILABLE. THIS FAILURE MODE DID NOT UPGRADE THE FUNCTIONAL  
 CRITICALITY.

APPENDIX C  
ASSESSMENT WORKSHEET

ASSESSMENT DATE: 10/08/86  
 ASSESSMENT ID: DPS-301  
 NASA FMEA #: 05-5-B21-1-1

NASA DATA:  
 BASELINE [ ]  
 NEW [ X ]

SUBSYSTEM: DPS  
 MDAC ID: 301  
 ITEM: X/Y DEFLECTION AMPLIFIERS

LEAD ANALYST: H J LOWERY

ASSESSMENT:

	CRITICALITY FLIGHT HDW/FUNC	REDUNDANCY SCREENS			CIL ITEM
		A	B	C	
NASA	[ 3 /1R ]	[ P ]	[ P ]	[ P ]	[ ] *
IOA	[ 3 /1R ]	[ P ]	[ P ]	[ P ]	[ ]
COMPARE	[ / ]	[ ]	[ ]	[ ]	[ ]

RECOMMENDATIONS: (If different from NASA)

[ / ] [ ] [ ] [ ] [ ]  
 (ADD/DELETE)

\* CIL RETENTION RATIONALE: (If applicable)

ADEQUATE [ ]  
 INADEQUATE [ ]

REMARKS:

CRTS (DUS) ARE ESSENTIAL FOR LIFE OR VEHICLE.  
 NASA AGREED WITH THE IOA ASSESSMENT RECOMMENDATION.  
 IOA DOES CONCUR WITH NASA'S REEVALUATION.

APPENDIX C  
ASSESSMENT WORKSHEET

ASSESSMENT DATE: 8/08/86  
 ASSESSMENT ID: DPS-302  
 NASA FMEA #: 05-5-B21-1-2

NASA DATA:  
 BASELINE [    ]  
 NEW [ X ]

SUBSYSTEM: DPS  
 MDAC ID: 302  
 ITEM: VIDEO AMPLIFIER

LEAD ANALYST: H J LOWERY

ASSESSMENT:

	CRITICALITY FLIGHT HDW/FUNC	REDUNDANCY SCREENS			CIL ITEM
		A	B	C	
NASA	[ 3 /1R ]	[ P ]	[ P ]	[ P ]	[    ] *
IOA	[ 3 /1R ]	[ P ]	[ P ]	[ P ]	[    ]
COMPARE	[ / ]	[    ]	[    ]	[    ]	[    ]

RECOMMENDATIONS: (If different from NASA)

[ / ] [    ] [    ] [    ] [    ]  
 (ADD/DELETE)

\* CIL RETENTION RATIONALE: (If applicable)

ADEQUATE [    ]  
 INADEQUATE [    ]

REMARKS:

CRTS (DUS) ARE ESSENTIAL FOR LIFE OR VEHICLE.  
 NASA AGREED WITH THE IOA ASSESSMENT RECOMMENDATION.  
 IOA DOES CONCUR WITH NASA'S REEVALUATION.

APPENDIX C  
ASSESSMENT WORKSHEET

ASSESSMENT DATE: 10/08/86  
 ASSESSMENT ID: DPS-303  
 NASA FMEA #: 05-5-B21-1-1

NASA DATA:  
 BASELINE [    ]  
 NEW [ X ]

SUBSYSTEM: DPS  
 MDAC ID: 303  
 ITEM: CATHODE-RAY TUBE

LEAD ANALYST: H J LOWERY

ASSESSMENT:

	CRITICALITY FLIGHT HDW/FUNC	REDUNDANCY SCREENS			CIL ITEM
		A	B	C	
NASA	[ 3 /1R ]	[ P ]	[ P ]	[ P ]	[    ] *
IOA	[ 3 /1R ]	[ P ]	[ P ]	[ P ]	[    ]
COMPARE	[ / ]	[    ]	[    ]	[    ]	[    ]

RECOMMENDATIONS: (If different from NASA)

[ / ] [    ] [    ] [    ] [    ]  
 (ADD/DELETE)

\* CIL RETENTION RATIONALE: (If applicable)

ADEQUATE [    ]  
 INADEQUATE [    ]

REMARKS:

CRTS (DUS) ARE ESSENTIAL FOR LIFE OR VEHICLE.  
 NASA AGREED WITH THE IOA ASSESSMENT RECOMMENDATION.  
 IOA DOES CONCUR WITH NASA'S REEVALUATION.

APPENDIX C  
ASSESSMENT WORKSHEET

ASSESSMENT DATE: 10/08/86  
 ASSESSMENT ID: DPS-304  
 NASA FMEA #: 05-5-B21-1-2

NASA DATA:  
 BASELINE [    ]  
 NEW [ X ]

SUBSYSTEM: DPS  
 MDAC ID: 304  
 ITEM: HI AND LOW VOLTAGE POWER SUPPLIES

LEAD ANALYST: H J LOWERY

ASSESSMENT:

	CRITICALITY FLIGHT HDW/FUNC	REDUNDANCY SCREENS			CIL ITEM
		A	B	C	
NASA	[ 3 /1R ]	[ P ]	[ P ]	[ P ]	[    ] *
IOA	[ 3 /1R ]	[ P ]	[ P ]	[ P ]	- [    ]
COMPARE	[ / ]	[    ]	[    ]	[    ]	[    ]

RECOMMENDATIONS: (If different from NASA)

[ / ] [    ] [    ] [    ] [    ]  
 (ADD/DELETE)

\* CIL RETENTION RATIONALE: (If applicable)

ADEQUATE [    ]  
 INADEQUATE [    ]

REMARKS:

CRTS (DUS) ARE ESSENTIAL FOR LIFE OR VEHICLE.  
 NASA AGREED WITH THE IOA ASSESSMENT RECOMMENDATION.

APPENDIX C  
ASSESSMENT WORKSHEET

ASSESSMENT DATE: 10/08/86  
 ASSESSMENT ID: DPS-305  
 NASA FMEA #: 05-6S-BRPC4-1

NASA DATA:  
 BASELINE [ ]  
 NEW [ X ]

SUBSYSTEM: DPS  
 MDAC ID: 305  
 ITEM: RPC

LEAD ANALYST: H J LOWERY

ASSESSMENT:

	CRITICALITY FLIGHT HDW/FUNC	REDUNDANCY SCREENS			CIL ITEM
		A	B	C	
NASA	[ 3 /1R ]	[ P ]	[ P ]	[ P ]	[ ] *
IOA	[ 3 /1R ]	[ P ]	[ P ]	[ P ]	[ ]
COMPARE	[ / ]	[ ]	[ ]	[ ]	[ ]

RECOMMENDATIONS: (If different from NASA)

[ / ] [ ] [ ] [ ] [ ]  
 (ADD/DELETE)

\* CIL RETENTION RATIONALE: (If applicable)

ADEQUATE [ ]  
 INADEQUATE [ ]

REMARKS:

CRTS (DUS) ARE ESSENTIAL FOR LIFE OR VEHICLE. VERIFICATION IN FLIGHT OF REDUNDANT STRINGS WHICH IS PROVIDED BY MDM MEASUREMENTS MAY BE ERRONEOUS SINCE THE STATUS MEASUREMENT DERIVATION IS INITIATED BY A REDUNDANT CIRCUIT.  
 NASA AGREED WITH THE IOA ASSESSMENT RECOMMENDATION.



APPENDIX C  
ASSESSMENT WORKSHEET

ASSESSMENT DATE: 10/08/86  
 ASSESSMENT ID: DPS-306  
 NASA FMEA #: 05-5-B23-1-2

NASA DATA:  
 BASELINE [ X ]  
 NEW [ ]

SUBSYSTEM: DPS  
 MDAC ID: 306  
 ITEM: MEMORY

LEAD ANALYST: H J LOWERY

ASSESSMENT:

	CRITICALITY FLIGHT HDW/FUNC	REDUNDANCY SCREENS			CIL ITEM
		A	B	C	
NASA	[ 3 /1R ]	[ P ]	[ P ]	[ P ]	[ ] *
IOA	[ 3 /1R ]	[ P ]	[ P ]	[ P ]	[ ]
COMPARE	[ / ]	[ ]	[ ]	[ ]	[ ]

RECOMMENDATIONS: (If different from NASA)

[ / ] [ ] [ ] [ ] [ ]  
 (ADD/DELETE)

\* CIL RETENTION RATIONALE: (If applicable)

ADEQUATE [ ]  
 INADEQUATE [ ]

REMARKS:

NO DIFFERENCES. THIS FAILURE MODE DID NOT UPGRADE THE FUNCTIONAL CRITICALITY.

APPENDIX C  
ASSESSMENT WORKSHEET

ASSESSMENT DATE: 10/08/86  
 ASSESSMENT ID: DPS-307  
 NASA FMEA #: 05-5-B23-1-2

NASA DATA:  
 BASELINE [ X ]  
 NEW [ ]

SUBSYSTEM: DPS  
 MDAC ID: 307  
 ITEM: KEYBOARD ADAPTER

LEAD ANALYST: H J LOWERY

ASSESSMENT:

CRITICALITY FLIGHT HDW/FUNC	REDUNDANCY SCREENS			CIL ITEM
	A	B	C	
NASA [ 3 /1R ]	[ P ]	[ P ]	[ P ]	[ ] *
IOA [ 3 /1R ]	[ P ]	[ P ]	[ P ]	[ ]
COMPARE [ / ]	[ ]	[ ]	[ ]	[ ]

RECOMMENDATIONS: (If different from NASA)

[ / ] [ ] [ ] [ ] [ ]  
 (ADD/DELETE)

\* CIL RETENTION RATIONALE: (If applicable)

ADEQUATE [ ]  
 INADEQUATE [ ]

REMARKS:

NO DIFFERENCES. THIS FAILURE MODE DID NOT UPGRADE THE FUNCTIONAL CRITICALITY.

APPENDIX C  
ASSESSMENT WORKSHEET

ASSESSMENT DATE: 10/14/86  
 ASSESSMENT ID: DPS-307A  
 NASA FMEA #: 05-5-B23-1-3

NASA DATA:  
 BASELINE [ X ]  
 NEW [ ]

SUBSYSTEM: DPS  
 MDAC ID: 307  
 ITEM: KEYBOARD ADAPTER

LEAD ANALYST: H J LOWERY

ASSESSMENT:

	CRITICALITY FLIGHT HDW/FUNC	REDUNDANCY SCREENS			CIL ITEM
		A	B	C	
NASA	[ 2 /1R ]	[ P ]	[ P ]	[ P ]	[ X ] *
IOA	[ 3 /1R ]	[ P ]	[ P ]	[ P ]	[ ]
COMPARE	[ N / ]	[ ]	[ ]	[ ]	[ N ]

RECOMMENDATIONS: (If different from NASA)

[ / ] [ ] [ ] [ ] [ ]  
 (ADD/DELETE)

\* CIL RETENTION RATIONALE: (If applicable)

ADEQUATE [ X ]  
 INADEQUATE [ ]

REMARKS:

MULTIPLE FAILURES ARE INCONSISTENT WITH NSTS 22206. SIMULTANEOUS DISSIMILAR FAILURES WERE EXCLUDED FROM THE IOA. PREMATURE TRANSITION FROM ONE MODE TO ANOTHER MODE WHEN OPS KEYBOARD ENTRY IS TO BE CLEARED IS A TWO FAILURE EFFECT SINCE A PREVIOUS FAILURE IS REQUIRED TO NECESSITATE CREW INITIATION OF OPS MODE RECALL, AS STATED IN NASA FMEA 05-5-B23-1-3. IOA DOES CONCUR WITH NASA'S REEVALUATION AND RATIONALE.

APPENDIX C  
ASSESSMENT WORKSHEET

ASSESSMENT DATE: 10/08/86  
 ASSESSMENT ID: DPS-308  
 NASA FMEA #: 05-5-B23-1-2

NASA DATA:  
 BASELINE [ X ]  
 NEW [ ]

SUBSYSTEM: DPS  
 MDAC ID: 308  
 ITEM: SYMBOL GENERATOR

LEAD ANALYST: H J LOWERY

ASSESSMENT:

	CRITICALITY FLIGHT HDW/FUNC	REDUNDANCY SCREENS			CIL ITEM
		A	B	C	
NASA	[ 3 /1R ]	[ P ]	[ P ]	[ P ]	[ ] *
IOA	[ 3 /1R ]	[ P ]	[ P ]	[ P ]	[ ]
COMPARE	[ / ]	[ ]	[ ]	[ ]	[ ]

RECOMMENDATIONS: (If different from NASA)

[ / ] [ ] [ ] [ ] [ ]  
 (ADD/DELETE)

\* CIL RETENTION RATIONALE: (If applicable)

ADEQUATE [ ]  
 INADEQUATE [ ]

REMARKS:

NO DIFFERENCES. THIS FAILURE MODE DID NOT UPGRADE THE FUNCTIONAL CRITICALITY.

APPENDIX C  
ASSESSMENT WORKSHEET

ASSESSMENT DATE: 10/14/86  
 ASSESSMENT ID: DPS-308A  
 NASA FMEA #: 05-5-B23-1-1

NASA DATA:  
 BASELINE [ X ]  
 NEW [ ]

SUBSYSTEM: DPS  
 MDAC ID: 308  
 ITEM: SYMBOL GENERATOR

LEAD ANALYST: H J LOWERY

ASSESSMENT:

	CRITICALITY FLIGHT HDW/FUNC	REDUNDANCY SCREENS			CIL ITEM
		A	B	C	
NASA	[ 3. /1R ]	[ P ]	[ P ]	[ P ]	[ ] *
IOA	[ 3 /1R ]	[ P ]	[ P ]	[ P ]	[ ]
COMPARE	[ / ]	[ ]	[ ]	[ ]	[ ]

RECOMMENDATIONS: (If different from NASA)

[ / ] [ ] [ ] [ ] [ ] (ADD/DELETE)

\* CIL RETENTION RATIONALE: (If applicable)

ADEQUATE [ ]  
 INADEQUATE [ ]

REMARKS:

THIS FAILURE MODE "NO OUTPUT/ERRONEOUS/ERRATIC OUTPUT" IS CONSIDERED TO BE COVERED BY THIS ROCKWELL FMEA WITH FAILURE MODE "LOSS OF OUTPUT".  
 NO DIFFERENCES. THIS FAILURE MODE DID NOT UPGRADE THE FUNCTIONAL CRITICALITY.

**APPENDIX C-  
ASSESSMENT WORKSHEET**

ASSESSMENT DATE: 10/08/86  
 ASSESSMENT ID: DPS-309  
 NASA FMEA #: 05-5-B23-1-2

NASA DATA:  
 BASELINE [ X ]  
 NEW [ ]

SUBSYSTEM: DPS  
 MDAC ID: 309  
 ITEM: MIA

LEAD ANALYST: H J LOWERY

**ASSESSMENT:**

	CRITICALITY FLIGHT HDW/FUNC	REDUNDANCY SCREENS			CIL ITEM
		A	B	C	
NASA	[ 3 /1R ]	[ P ]	[ P ]	[ P ]	[ ] *
IOA	[ 3 /1R ]	[ P ]	[ P ]	[ P ]	[ ]
COMPARE	[ / ]	[ ]	[ ]	[ ]	[ ]

**RECOMMENDATIONS: (If different from NASA)**

[ / ] [ ] [ ] [ ] [ ]  
 (ADD/DELETE)

**\* CIL RETENTION RATIONALE: (If applicable)**

ADEQUATE [ ]  
 INADEQUATE [ ]

REMARKS:  
 NO DIFFERENCES.

APPENDIX C  
ASSESSMENT WORKSHEET

ASSESSMENT DATE: 10/08/86  
 ASSESSMENT ID: DPS-310  
 NASA FMEA #: 05-5-B23-1-2

NASA DATA:  
 BASELINE [ X ]  
 NEW [ ]

SUBSYSTEM: DPS  
 MDAC ID: 310  
 ITEM: CONTROL LOGIC

LEAD ANALYST: H J LOWERY

ASSESSMENT:

	CRITICALITY FLIGHT HDW/FUNC	REDUNDANCY SCREENS			CIL ITEM
		A	B	C	
NASA	[ 3 /1R ]	[ P ]	[ P ]	[ P ]	[ ] *
IOA	[ 3 /1R ]	[ P ]	[ P ]	[ P ]	[ ]
COMPARE	[ / ]	[ ]	[ ]	[ ]	[ ]

RECOMMENDATIONS: (If different from NASA)

[ / ] [ ] [ ] [ ] [ ] (ADD/DELETE)

\* CIL RETENTION RATIONALE: (If applicable)

ADEQUATE [ ]  
 INADEQUATE [ ]

REMARKS:  
 NO DIFFERENCES.

APPENDIX C  
ASSESSMENT WORKSHEET

ASSESSMENT DATE: 10/08/86  
 ASSESSMENT ID: DPS-311  
 NASA FMEA #: 05-5-B23-1-2

NASA DATA:  
 BASELINE [ X ]  
 NEW [ ]

SUBSYSTEM: DPS  
 MDAC ID: 311  
 ITEM: POWER SUPPLIES

LEAD ANALYST: H J LOWERY

ASSESSMENT:

	CRITICALITY FLIGHT HDW/FUNC	REDUNDANCY SCREENS			CIL ITEM
		A	B	C	
NASA	[ 3 /1R ]	[ P ]	[ P ]	[ P ]	[ ] *
IOA	[ 3 /1R ]	[ P ]	[ P ]	[ P ]	[ ]
COMPARE	[ / ]	[ ]	[ ]	[ ]	[ ]

RECOMMENDATIONS: (If different from NASA)

[ / ] [ ] [ ] [ ] [ ]  
 (ADD/DELETE)

\* CIL RETENTION RATIONALE: (If applicable)

ADEQUATE [ ]  
 INADEQUATE [ ]

REMARKS:  
 NO DIFFERENCES.



APPENDIX C  
ASSESSMENT WORKSHEET

ASSESSMENT DATE: 10/08/86  
 ASSESSMENT ID: DPS-312  
 NASA FMEA #: 05-6S-BRPC5-1

NASA DATA:  
 BASELINE [ X ]  
 NEW [ ]

SUBSYSTEM: DPS  
 MDAC ID: 312  
 ITEM: RPC

LEAD ANALYST: H J LOWERY

ASSESSMENT:

	CRITICALITY FLIGHT HDW/FUNC	REDUNDANCY SCREENS			CIL ITEM
		A	B	C	
NASA	[ 3 /1R ]	[ P ]	[ P ]	[ P ]	[ ] *
IOA	[ 3 /1R ]	[ P ]	[ P ]	[ P ]	[ ]
COMPARE	[ / ]	[ ]	[ ]	[ ]	[ ]

RECOMMENDATIONS: (If different from NASA)

[ / ] [ ] [ ] [ ] [ ] (ADD/DELETE)

\* CIL RETENTION RATIONALE: (If applicable)

ADEQUATE [ ]  
 INADEQUATE [ ]

REMARKS:

VERIFICATION IN FLIGHT OF REDUNDANT STRINGS WHICH IS PROVIDED BY  
 MDM MEASUREMENTS MAY BE ERRONEOUS SINCE THE STATUS MEASUREMENT  
 DERIVATION IS INITIATED BY A REDUNDANT CIRCUIT.  
 THIS FAILURE MODE DID NOT UPGRADE THE FUNCTIONAL CRITICALITY.

APPENDIX C  
ASSESSMENT WORKSHEET

ASSESSMENT DATE: 10/14/86  
 ASSESSMENT ID: DPS-312A  
 NASA FMEA #: 05-6S-BDI01-1

NASA DATA:  
 BASELINE [ X ]  
 NEW [ ]

SUBSYSTEM: DPS  
 MDAC ID: 312  
 ITEM: RPC

LEAD ANALYST: H J LOWERY

ASSESSMENT:

	CRITICALITY FLIGHT HDW/FUNC	REDUNDANCY SCREENS			CIL ITEM
		A	B	C	
NASA	[ 3 /1R ]	[ P ]	[ P ]	[ P ]	[ ] *
IOA	[ 3 /1R ]	[ P ]	[ P ]	[ P ]	[ ]
COMPARE	[ / ]	[ ]	[ ]	[ ]	[ ]

RECOMMENDATIONS: (If different from NASA)

[ / ] [ ] [ ] [ ] [ ]  
 (ADD/DELETE)

\* CIL RETENTION RATIONALE: (If applicable)

ADEQUATE [ ]  
 INADEQUATE [ ]

REMARKS:

THIS NASA FMEA NUMBER WAS COVERED IN THE ORIGINAL IOA ANALYSIS. THIS FAILURE MODE "OPEN/CLOSED/PREMATURE OPERATION" IS CONSIDERED TO BE COVERED BY THIS ROCKWELL FMEA WITH FAILURE MODE "OPENS". IOA DOES CONCUR WITH NASA'S REEVALUATION. THIS FAILURE MODE DID NOT UPGRADE THE FUNCTIONAL CRITICALITY. VERIFICATION IN FLIGHT OF REDUNDANT STRINGS WHICH IS PROVIDED BY MDM MEASUREMENTS MAY BE ERRONEOUS SINCE THE STATUS MEASUREMENT DERIVATION IS INITIATED BY A REDUNDANT CIRCUIT.

APPENDIX C  
ASSESSMENT WORKSHEET

ASSESSMENT DATE: 10/14/86  
 ASSESSMENT ID: DPS-312B  
 NASA FMEA #: 05-6S-BSW4-1

NASA DATA:  
 BASELINE [ X ]  
 NEW [ ]

SUBSYSTEM: DPS  
 MDAC ID: 312  
 ITEM: RPC

LEAD ANALYST: H J LOWERY

ASSESSMENT:

	CRITICALITY FLIGHT HDW/FUNC	REDUNDANCY SCREENS			CIL ITEM
		A	B	C	
NASA	[ 3 /1R ]	[ P ]	[ P ]	[ P ]	[ ] *
IOA	[ 3 /1R ]	[ P ]	[ P ]	[ P ]	[ ]
COMPARE	[ / ]	[ ]	[ ]	[ ]	[ ]

RECOMMENDATIONS: (If different from NASA)

[ / ] [ ] [ ] [ ] [ ]  
 (ADD/DELETE)

\* CIL RETENTION RATIONALE: (If applicable)

ADEQUATE [ ]  
 INADEQUATE [ ]

REMARKS:

THIS NASA FMEA NUMBER WAS NOT COVERED IN THE ORIGINAL IOA ANALYSIS. THIS FAILURE MODE "OPEN/CLOSED/PREATURE OPERATION" IS CONSIDERED TO BE COVERED BY THIS ROCKWELL FMEA WITH FAILURE MODE "PREATURE OPERATION".

VERIFICATION IN FLIGHT OF REDUNDANT STRINGS WHICH IS PROVIDED BY THE MDM MEASUREMENTS MAY BE ERRONEOUS SINCE THE STATUS MEASUREMENT DERIVATION IS INITIATED BY A REDUNDANT CIRCUIT. IOA DOES CONCUR WITH NASA'S REEVALUATION. THIS FAILURE MODE DID NOT UPGRADE THE FUNCTIONAL CRITICALITY.

APPENDIX C  
ASSESSMENT WORKSHEET

ASSESSMENT DATE: 10/14/86  
 ASSESSMENT ID: DPS-312C  
 NASA FMEA #: 05-6S-BFUS2-1

NASA DATA:  
 BASELINE [ X ]  
 NEW [ ]

SUBSYSTEM: DPS  
 MDAC ID: 312  
 ITEM: RPC

LEAD ANALYST: H J LOWERY

ASSESSMENT:

	CRITICALITY FLIGHT HDW/FUNC	REDUNDANCY SCREENS			CIL ITEM
		A	B	C	
NASA	[ 3 /1R ]	[ P ]	[ P ]	[ P ]	[ ] *
IOA	[ 3 /1R ]	[ P ]	[ P ]	[ P ]	[ ]
COMPARE	[ / ]	[ ]	[ ]	[ ]	[ ]

RECOMMENDATIONS: (If different from NASA)

[ / ] [ ] [ ] [ ] [ ]  
 (ADD/DELETE)

\* CIL RETENTION RATIONALE: (If applicable)

ADEQUATE [ ]  
 INADEQUATE [ ]

REMARKS:

THIS NASA FMEA NUMBER WAS NOT COVERED IN THE ORIGINAL IOA ANALYSIS. THIS FAILURE MODE "OPEN/CLOSED/PREATURE OPERATION" IS CONSIDERED TO BE COVERED BY THIS ROCKWELL FMEA WITH FAILURE MODE "PREATURE OPERATION".  
 VERIFICATION IN FLIGHT OF REDUNDANT STRINGS WHICH IS PROVIDED BY THE MDM MEASUREMENTS MAY BE ERRONEOUS SINCE THE STATUS MEASUREMENT DERIVATION IS INITIATED BY A REDUNDANT CIRCUIT. IOA DOES CONCUR WITH NASA'S REEVALUATION. THIS FAILURE MODE DID NOT UPGRADE THE FUNCTIONAL CRITICALITY.

APPENDIX C  
ASSESSMENT WORKSHEET

ASSESSMENT DATE: 10/08/86  
 ASSESSMENT ID: DPS-313  
 NASA FMEA #: 05-5-B25-1-3

NASA DATA:  
 BASELINE [ X ]  
 NEW [ ]

SUBSYSTEM: DPS  
 MDAC ID: 313  
 ITEM: LOAD SWITCH

LEAD ANALYST: H J LOWERY

ASSESSMENT:

	CRITICALITY FLIGHT HDW/FUNC	REDUNDANCY SCREENS			CIL ITEM
		A	B	C	
NASA	[ 3 /1R ]	[ P ]	[ P ]	[ P ]	[ ] *
IOA	[ 3 /3 ]	[ NA ]	[ NA ]	[ NA ]	[ ]
COMPARE	[ /N ]	[ N ]	[ N ]	[ N ]	[ ]

RECOMMENDATIONS: (If different from NASA)

[ / ] [ ] [ ] [ ] [ ] (ADD/DELETE)

\* CIL RETENTION RATIONALE: (If applicable)

ADEQUATE [ ]  
 INADEQUATE [ ]

REMARKS:

DEU'S ARE NOT NORMALLY RELOADED DURING A MISSION. SWITCH IS NOT NEEDED.  
 IOA DOES CONCUR WITH NASA'S REEVALUATION.

**APPENDIX C  
ASSESSMENT WORKSHEET**

ASSESSMENT DATE: 10/08/86  
 ASSESSMENT ID: DPS-314  
 NASA FMEA #: 05-5-B26-1-2

NASA DATA:  
 BASELINE [ X ]  
 NEW [ ]

SUBSYSTEM: DPS  
 MDAC ID: 314  
 ITEM: FUNCTION SWITCH

LEAD ANALYST: H J LOWERY

**ASSESSMENT:**

	CRITICALITY FLIGHT HDW/FUNC	REDUNDANCY SCREENS			CIL ITEM
		A	B	C	
NASA	[ 3 /1R ]	[ P ]	[ P ]	[ P ]	[ ] *
IOA	[ 3 /1R ]	[ P ]	[ P ]	[ P ]	[ ]
COMPARE	[ / ]	[ ]	[ ]	[ ]	[ ]

RECOMMENDATIONS: (If different from NASA)

[ / ] [ ] [ ] [ ] [ ]  
 (ADD/DELETE)

\* CIL RETENTION RATIONALE: (If applicable)

ADEQUATE [ ]  
 INADEQUATE [ ]

**REMARKS:**

NO DIFFERENCES. THIS FAILURE MODE DID NOT UPGRADE THE FUNCTIONAL CRITICALITY.

APPENDIX C  
ASSESSMENT WORKSHEET

ASSESSMENT DATE: 10/14/86  
 ASSESSMENT ID: DPS-314A  
 NASA FMEA #: 05-5-B26-1-1

NASA DATA:  
 BASELINE [ X ]  
 NEW [ ]

SUBSYSTEM: DPS  
 MDAC ID: 314  
 ITEM: FUNCTION SWITCH

LEAD ANALYST: H J LOWERY

ASSESSMENT:

	CRITICALITY FLIGHT HDW/FUNC	REDUNDANCY SCREENS			CIL ITEM
		A	B	C	
NASA	[ 3 /1R ]	[ P ]	[ P ]	[ P ]	[ ] *
IOA	[ 3 /1R ]	[ P ]	[ P ]	[ P ]	[ ]
COMPARE	[ / ]	[ ]	[ ]	[ ]	[ ]

RECOMMENDATIONS: (If different from NASA)

[ / ] [ ] [ ] [ ] [ ]  
 (ADD/DELETE)

\* CIL RETENTION RATIONALE: (If applicable)

ADEQUATE [ ]  
 INADEQUATE [ ]

REMARKS:

NO DIFFERENCES. THIS FAILURE MODE DID NOT UPGRADE THE FUNCTIONAL CRITICALITY.

APPENDIX C  
ASSESSMENT WORKSHEET

ASSESSMENT DATE: 10/14/86  
 ASSESSMENT ID: DPS-314B  
 NASA FMEA #: 05-5-B26-1-3

NASA DATA:  
 BASELINE [ X ]  
 NEW [ ]

SUBSYSTEM: DPS  
 MDAC ID: 314  
 ITEM: FUNCTION SWITCH

LEAD ANALYST: H J LOWERY

ASSESSMENT:

	CRITICALITY FLIGHT HDW/FUNC	REDUNDANCY SCREENS			CIL ITEM
		A	B	C	
NASA	[ 3 /1R ]	[ P ]	[ P ]	[ P ]	[ ] *
IOA	[ 3 /1R ]	[ P ]	[ P ]	[ P ]	[ ]
COMPARE	[ / ]	[ ]	[ ]	[ ]	[ ]

RECOMMENDATIONS: (If different from NASA)

[ / ] [ ] [ ] [ ] [ ] (ADD/DELETE)

\* CIL RETENTION RATIONALE: (If applicable)

ADEQUATE [ ]  
 INADEQUATE [ ]

REMARKS:

NO DIFFERENCES. THIS FAILURE MODE DID NOT UPGRADE THE FUNCTIONAL CRITICALITY.



APPENDIX C  
ASSESSMENT WORKSHEET

ASSESSMENT DATE: 10/08/86  
 ASSESSMENT ID: DPS-315  
 NASA FMEA #: 05-5-B14-1-1

NASA DATA:  
 BASELINE [ X ]  
 NEW [ ]

SUBSYSTEM: DPS  
 MDAC ID: 315  
 ITEM: DATA BUS COUPLER (DBC)

LEAD ANALYST: H J LOWERY

ASSESSMENT:

	CRITICALITY FLIGHT HDW/FUNC	REDUNDANCY SCREENS			CIL ITEM
		A	B	C	
NASA	[ 2 /1R ]	[ P ]	[ P ]	[ P ]	[ X ] *
IOA	[ 3 /1R ]	[ P ]	[ P ]	[ P ]	[ ]
COMPARE	[ N / ]	[ ]	[ ]	[ ]	[ N ]

RECOMMENDATIONS: (If different from NASA)

[ / ] [ ] [ ] [ ] [ ]  
 (ADD/DELETE)

\* CIL RETENTION RATIONALE: (If applicable)

ADEQUATE [ X ]  
 INADEQUATE [ ]

REMARKS:

IOA DOES CONCUR WITH NASA'S REEVALUATION AND RATIONALE.  
 REDUNDANT HARDWARE WOULD NOT BE ACCESSIBLE DURING LIFTOFF AND DEORBIT.  
 IF THE SECOND RELATED FAILURE WAS ASSOCIATED WITH EITHER PRE-VALVES OR PURGE DURING RTLS ABORT THIS FAILURE WOULD RESULT IN LOSS OF LIFE/VEHICLE. SIMULTANEOUS DISSIMILAR FAILURES WERE EXCLUDED FROM THE IOA.  
 MULTIPLE FAILURES ARE INCONSISTENT WITH THE NSTS 22206.

APPENDIX C  
ASSESSMENT WORKSHEET

ASSESSMENT DATE: 10/08/86  
 ASSESSMENT ID: DPS-316  
 NASA FMEA #: 05-5-B13-1-4

NASA DATA:  
 BASELINE [ X ]  
 NEW [ ]

SUBSYSTEM: DPS  
 MDAC ID: 316  
 ITEM: DBIA

LEAD ANALYST: H J LOWERY

ASSESSMENT:

	CRITICALITY FLIGHT HDW/FUNC	REDUNDANCY SCREENS			CIL ITEM
		A	B	C	
NASA	[ 3 /2R ]	[ P ]	[ NA ]	[ P ]	[ ] *
IOA	[ 3 /2R ]	[ P ]	[ NA ]	[ P ]	[ ]
COMPARE	[ / ]	[ ]	[ ]	[ ]	[ ]

RECOMMENDATIONS: (If different from NASA)

[ / ] [ ] [ ] [ ] [ ]  
 (ADD/DELETE)

\* CIL RETENTION RATIONALE: (If applicable)

ADEQUATE [ ]  
 INADEQUATE [ ]

REMARKS:

NO DIFFERENCES. THIS FAILURE MODE DID NOT UPGRADE THE FUNCTIONAL CRITICALITY.

APPENDIX C  
ASSESSMENT WORKSHEET

ASSESSMENT DATE: 10/14/86  
 ASSESSMENT ID: DPS-316A  
 NASA FMEA #: 05-6S-BCKT-2-1

NASA DATA:  
 BASELINE [ X ]  
 NEW [ ]

SUBSYSTEM: DPS  
 MDAC ID: 316  
 ITEM: DBIA

LEAD ANALYST: H J LOWERY

ASSESSMENT:

	CRITICALITY FLIGHT HDW/FUNC	REDUNDANCY SCREENS			CIL ITEM
		A	B	C	
NASA	[ 3 /3 ]	[ P ]	[ P ]	[ P ]	[ ] *
IOA	[ 3 /2R ]	[ P ]	[ NA ]	[ P ]	[ ]
COMPARE	[ /N ]	[ ]	[ N ]	[ ]	[ ]

RECOMMENDATIONS: (If different from NASA)

[ / ] [ ] [ ] [ ] [ ] (ADD/DELETE)

\* CIL RETENTION RATIONALE: (If applicable)

ADEQUATE [ ]  
 INADEQUATE [ ]

REMARKS:

THIS FAILURE MODE "OPEN/SHORT/ERRONEOUS/ERRATIC OUTPUT" IS CONSIDERED TO BE COVERED BY THIS ROCKWELL FMEA WITH FAILURE MODE "ALL CREDIBLE MODES".  
 THE IOA DOES CONCUR WITH NASA'S REEVALUATION. THIS FAILURE MODE DID NOT UPGRADE THE FUNCTIONAL CRITICALITY.

APPENDIX C  
ASSESSMENT WORKSHEET

ASSESSMENT DATE: 10/27/86  
 ASSESSMENT ID: DPS-317  
 NASA FMEA #: 05-6S-BRES4-1

NASA DATA:  
 BASELINE [    ]  
 NEW [ X ]

SUBSYSTEM: DPS  
 MDAC ID: 317  
 ITEM: RESISTOR

LEAD ANALYST: H J LOWERY

ASSESSMENT:

	CRITICALITY FLIGHT HDW/FUNC	REDUNDANCY SCREENS			CIL ITEM
		A	B	C	
NASA	[ 3 / 3 ]	[ P ]	[ P ]	[ P ]	[    ] *
IOA	[ 3 / 3 ]	[ NA ]	[ NA ]	[ NA ]	[    ]
COMPARE	[    /    ]	[ N ]	[ N ]	[ N ]	[    ]

RECOMMENDATIONS: (If different from NASA)

[    /    ]    [    ]    [    ]    [    ]    [    ]  
 (ADD/DELETE)

\* CIL RETENTION RATIONALE: (If applicable)

ADEQUATE [    ]  
 INADEQUATE [    ]

REMARKS:

THE IOA DID NOT COVER THIS ITEM IN THE ORIGINAL ANALYSIS.  
 THE IOA DOES CONCUR WITH NASA'S REEVALUATION.  
 ACCORDING TO NSTS 22206, REDUNDANCY SCREENS MUST BE "NA" OR BLANK  
 FOR FMEAS WITH A CRITICALITY OF 3/3.

APPENDIX C  
ASSESSMENT WORKSHEET

ASSESSMENT DATE: 10/14/86  
 ASSESSMENT ID: DPS-318  
 NASA FMEA #: 05-6S-BRPC4-2

NASA DATA:  
 BASELINE [    ]  
 NEW [ X ]

SUBSYSTEM: DPS  
 MDAC ID: 318  
 ITEM: RPC

LEAD ANALYST: H J LOWERY

ASSESSMENT:

	CRITICALITY FLIGHT HDW/FUNC	REDUNDANCY SCREENS			CIL ITEM
		A	B	C	
NASA	[ 3 / 3 ]	[ P ]	[ P ]	[ P ]	[    ] *
IOA	[ 3 / 3 ]	[ NA ]	[ NA ]	[ NA ]	[    ]
COMPARE	[    /    ]	[ N ]	[ N ]	[ N ]	[    ]

RECOMMENDATIONS: (If different from NASA)

[    /    ]    [    ]    [    ]    [    ]    [    ]  
 (ADD/DELETE)

\* CIL RETENTION RATIONALE: (If applicable)

ADEQUATE [    ]  
 INADEQUATE [    ]

REMARKS:

THIS FAILURE MODE "PREMATURE OPERATION" IS CONSIDERED TO BE COVERED BY THIS ROCKWELL FMEA WITH FAILURE MODE "INADVERTENT OUTPUT".

NO EFFECT SINCE DU WILL HAVE POWER APPLIED PREMATURELY, BUT DISPLAY WILL NOT APPEAR UNTIL THE DEU IS TURNED ON.

NASA AGREED WITH THE IOA ASSESSMENT RECOMMENDATION.

THE IOA DID NOT COVER THIS FAILURE MODE IN THE ORIGINAL ANALYSIS. ACCORDING TO NSTS 22206, REDUNDANCY SCREENS MUST BE "NA" OR BLANK FOR FMEAS WITH A CRITICALITY OF 3/3.

APPENDIX C  
ASSESSMENT WORKSHEET

ASSESSMENT DATE: 10/14/86  
 ASSESSMENT ID: DPS-319  
 NASA FMEA #: 05-6S-BSW4-2

NASA DATA:  
 BASELINE [    ]  
 NEW [ X ]

SUBSYSTEM: DPS  
 MDAC ID: 319  
 ITEM: SWITCH, CRT POWER

LEAD ANALYST: H J LOWERY

ASSESSMENT:

	CRITICALITY FLIGHT HDW/FUNC	REDUNDANCY SCREENS			CIL ITEM
		A	B	C	
NASA	[ 3 / 3 ]	[ P ]	[ P ]	[ P ]	[    ] *
IOA	[ 3 / 3 ]	[ NA ]	[ NA ]	[ NA ]	[    ]
COMPARE	[ / ]	[ N ]	[ N ]	[ N ]	[    ]

RECOMMENDATIONS: (If different from NASA)

[ / ] [ ] [ ] [ ] [ ]  
 (ADD/DELETE)

\* CIL RETENTION RATIONALE: (If applicable)

ADEQUATE [    ]  
 INADEQUATE [    ]

REMARKS:

THIS FAILURE MODE "PREMATURE OPERATION" IS CONSIDERED TO BE COVERED THIS ROCKWELL FMEA WITH FAILURE MODE "PREMATURE OPERATION".  
 NO EFFECT SINCE DU WILL HAVE POWER APPLIED PREMATURELY, BUT DISPLAY WILL NOT APPEAR UNTIL DEU IS TURNED ON.  
 NASA AGREED WITH THE IOA ASSESSMENT RECOMMENDATION.  
 IOA DID NOT COVER THIS FAILURE MODE IN THE ORIGINAL ANALYSIS.  
 ACCORDING TO NSTS 22206, REDUNDANCY SCREENS MUST BE "NA" OR BLANK FOR FMEAS WITH A CRITICALITY OF 3/3.

APPENDIX C  
ASSESSMENT WORKSHEET

ASSESSMENT DATE: 10/14/86  
 ASSESSMENT ID: DPS-320  
 NASA FMEA #: 05-6S-BRPC5-2

NASA DATA:  
 BASELINE [    ]  
 NEW [ X ]

SUBSYSTEM: DPS  
 MDAC ID: 320  
 ITEM: RPC

LEAD ANALYST: H J LOWERY

ASSESSMENT:

	CRITICALITY FLIGHT HDW/FUNC	REDUNDANCY SCREENS			CIL ITEM
		A	B	C	
NASA	[ 3 / 3 ]	[ P ]	[ P ]	[ P ]	[    ] *
IOA	[ 3 / 3 ]	[ NA ]	[ NA ]	[ NA ]	[    ]
COMPARE	[    /    ]	[ N ]	[ N ]	[ N ]	[    ]

RECOMMENDATIONS: (If different from NASA)

[    /    ]    [    ]    [    ]    [    ]    [    ]  
 (ADD/DELETE)

\* CIL RETENTION RATIONALE: (If applicable)

ADEQUATE [    ]  
 INADEQUATE [    ]

REMARKS:

THIS FAILURE MODE "PREMATURE OPERATION" IS CONSIDERED TO BE COVERED BY THIS ROCKWELL FMEA WITH FAILURE MODE "INADVERTENT OUTPUT".

NO EFFECT SINCE DEU WILL HAVE POWER APPLIED PREMATURELY.

IOA DID NOT COVER THIS FAILURE MODE IN THE ORIGINAL ANALYSIS.

NASA AGREED WITH THE IOA ASSESSMENT RECOMMENDATION.

ACCORDING TO NSTS 22206, REDUNDANCY SCREENS MUST BE "NA" OR BLANK FOR FMEAS WITH A CRITICALITY OF 3/3.

APPENDIX C  
ASSESSMENT WORKSHEET

ASSESSMENT DATE: 11/03/86  
 ASSESSMENT ID: DPS-321  
 NASA FMEA #: 05-6S-BDIO1-2 (NEW)

NASA DATA:  
 BASELINE [ ]  
 NEW [ X ]

SUBSYSTEM: DPS  
 MDAC ID: 321  
 ITEM: DIODE, SUPPRESSOR

LEAD ANALYST: H J LOWERY

ASSESSMENT:

	CRITICALITY FLIGHT HDW/FUNC	REDUNDANCY SCREENS			CIL ITEM
		A	B	C	
NASA	[ 3 / 3 ]	[ NA ]	[ NA ]	[ NA ]	[ ] *
IOA	[ 3 / 3 ]	[ NA ]	[ NA ]	[ NA ]	[ ]
COMPARE	[ / ]	[ ]	[ ]	[ ]	[ ]

RECOMMENDATIONS: (If different from NASA)

[ / ] [ ] [ ] [ ] [ ]  
 (ADD/DELETE)

\* CIL RETENTION RATIONALE: (If applicable)

ADEQUATE [ ]  
 INADEQUATE [ ]

REMARKS:

IOA DID NOT COVER THIS ITEM IN THE ORIGINAL ANALYSIS.  
 NASA AGREED WITH THE IOA ASSESSMENT RECOMMENDATION.  
 ACCORDING TO NSTS 22206, REDUNDANCY SCREENS MUST BE "NA" OR BLANK  
 FOR FMEAS WITH A CRITICALITY OF 3/3.



APPENDIX C  
ASSESSMENT WORKSHEET

ASSESSMENT DATE: 11/10/86  
 ASSESSMENT ID: DPS-322  
 NASA FMEA #: 05-6S-BSW4-3 (NEW)

NASA DATA:  
 BASELINE [ ]  
 NEW [ X ]

SUBSYSTEM: DPS  
 MDAC ID: 322  
 ITEM: SWITCH, CRT POWER

LEAD ANALYST: H J LOWERY

ASSESSMENT:

	CRITICALITY FLIGHT HDW/FUNC	REDUNDANCY SCREENS			CIL ITEM
		A	B	C	
NASA	[ 3 /1R ]	[ P ]	[ P ]	[ P ]	[ ] *
IOA	[ 3 /1R ]	[ P ]	[ P ]	[ P ]	[ ]
COMPARE	[ / ]	[ ]	[ ]	[ ]	[ ]

RECOMMENDATIONS: (If different from NASA)

[ / ] [ ] [ ] [ ] [ ]  
 (ADD/DELETE)

\* CIL RETENTION RATIONALE: (If applicable)

ADEQUATE [ ]  
 INADEQUATE [ ]

REMARKS:

REF. 05-6Q-2201-3. NASA-JSC FMEA & CIL REVIEW COMMENTS, 9-11-86.  
 IOA DID NOT COVER THIS FAILURE MDOE IN THE ORIGINAL ANALYSIS.  
 IOA DOES CONCUR WITH NASA'S REEVALUATION.

APPENDIX C  
ASSESSMENT WORKSHEET

ASSESSMENT DATE: 10/10/86  
 ASSESSMENT ID: DPS-400  
 NASA FMEA #: 05-5-B04-2-1

NASA DATA:  
 BASELINE [ X ]  
 NEW [ ]

SUBSYSTEM: DPS  
 MDAC ID: 400  
 ITEM: Tape transport mechanism

LEAD ANALYST: K. Pietz

ASSESSMENT:

	CRITICALITY FLIGHT HDW/FUNC	REDUNDANCY SCREENS			CIL ITEM
		A	B	C	
NASA	[ 3 /2R ]	[ P ]	[ P ]	[ P ]	[ ] *
IOA	[ 3 /2R ]	[ P ]	[ P ]	[ P ]	[ ]
COMPARE	[ / ]	[ ]	[ ]	[ ]	[ ]

RECOMMENDATIONS: (If different from NASA)

[ / ] [ ] [ ] [ ] [ ]  
 (ADD/DELETE)

\* CIL RETENTION RATIONALE: (If applicable)

ADEQUATE [ ]  
 INADEQUATE [ ]

REMARKS:  
 NO DIFFERENCES.

APPENDIX C  
ASSESSMENT WORKSHEET

ASSESSMENT DATE: 10/10/86  
 ASSESSMENT ID: DPS-401  
 NASA FMEA #: 05-5-B04-2-1

NASA DATA:  
 BASELINE [ X ]  
 NEW [ ]

SUBSYSTEM: DPS  
 MDAC ID: 401  
 ITEM: Tape transport mechanism

LEAD ANALYST: K. Pietz

ASSESSMENT:

	CRITICALITY FLIGHT HDW/FUNC	REDUNDANCY SCREENS			CIL ITEM
		A	B	C	
NASA	[ 3 /2R ]	[ P ]	[ P ]	[ P ]	[ ] **
IOA	[ 3 /2R ]	[ P ]	[ P ]	[ P ]	[ ]
COMPARE	[ / ]	[ ]	[ ]	[ ]	[ ]

RECOMMENDATIONS: (If different from NASA)

[ / ] [ ] [ ] [ ] [ ]  
 (ADD/DELETE)

\* CIL RETENTION RATIONALE: (If applicable)

ADEQUATE [ ]  
 INADEQUATE [ ]

REMARKS:  
 NO DIFFERENCES.

APPENDIX C  
ASSESSMENT WORKSHEET

ASSESSMENT DATE: 10/10/86  
 ASSESSMENT ID: DPS-402  
 NASA FMEA #: 05-5-BO4-2-1

NASA DATA:  
 BASELINE [ X ]  
 NEW [ ]

SUBSYSTEM: DPS  
 MDAC ID: 402  
 ITEM: Read electronics

LEAD ANALYST: K. Pietz

ASSESSMENT:

	CRITICALITY FLIGHT HDW/FUNC	REDUNDANCY SCREENS			CIL ITEM
		A	B	C	
NASA	[ 3 /2R ]	[ P ]	[ P ]	[ P ]	[ ] *
IOA	[ 3 /2R ]	[ P ]	[ P ]	[ P ]	[ ]
COMPARE	[ / ]	[ ]	[ ]	[ ]	[ ]

RECOMMENDATIONS: (If different from NASA)

[ / ] [ ] [ ] [ ] [ ] (ADD/DELETE)

\* CIL RETENTION RATIONALE: (If applicable)

ADEQUATE [ ]  
 INADEQUATE [ ]

REMARKS:  
 NO DIFFERENCES.

APPENDIX C  
ASSESSMENT WORKSHEET

ASSESSMENT DATE: 10/10/86  
 ASSESSMENT ID: DPS-403  
 NASA FMEA #: 05-5-B04-2-1

NASA DATA:  
 BASELINE [ X ]  
 NEW [ ]

SUBSYSTEM: DPS  
 MDAC ID: 403  
 ITEM: Read electronics

LEAD ANALYST: K. Pietz

ASSESSMENT:

	CRITICALITY FLIGHT HDW/FUNC	REDUNDANCY SCREENS			CIL ITEM
		A	B	C	
NASA	[ 3 /2R ]	[ P ]	[ P ]	[ P ]	[ ] *
IOA	[ 3 /2R ]	[ P ]	[ P ]	[ P ]	[ ]
COMPARE	[ / ]	[ ]	[ ]	[ ]	[ ]

RECOMMENDATIONS: (If different from NASA)

[ / ] [ ] [ ] [ ] [ ]  
 (ADD/DELETE)

\* CIL RETENTION RATIONALE: (If applicable)

ADEQUATE [ ]  
 INADEQUATE [ ]

REMARKS:  
 NO DIFFERENCES.

APPENDIX C  
ASSESSMENT WORKSHEET

ASSESSMENT DATE: 10/10/86  
 ASSESSMENT ID: DPS-404  
 NASA FMEA #: 05-5-B04-2-1

NASA DATA:  
 BASELINE [ X ]  
 NEW [ ]

SUBSYSTEM: DPS  
 MDAC ID: 404  
 ITEM: MIA

LEAD ANALYST: K. Pietz

ASSESSMENT:

	CRITICALITY FLIGHT HDW/FUNC	REDUNDANCY SCREENS			CIL ITEM
		A	B	C	
NASA	[ 3 /2R ]	[ P ]	[ P ]	[ P ]	[ ] *
IOA	[ 3 /2R ]	[ P ]	[ P ]	[ P ]	[ ]
COMPARE	[ / ]	[ ]	[ ]	[ ]	[ ]

RECOMMENDATIONS: (If different from NASA)

[ / ] [ ] [ ] [ ] [ ]  
 (ADD/DELETE)

\* CIL RETENTION RATIONALE: (If applicable)

ADEQUATE [ ]  
 INADEQUATE [ ]

REMARKS:  
 NO DIFFERENCES.

APPENDIX C  
ASSESSMENT WORKSHEET

ASSESSMENT DATE: 10/10/86  
 ASSESSMENT ID: DPS-405  
 NASA FMEA #: 05-5-B04-2-1

NASA DATA:  
 BASELINE [ X ]  
 NEW [ ]

SUBSYSTEM: DPS  
 MDAC ID: 405  
 ITEM: MIA

LEAD ANALYST: K. Pietz

ASSESSMENT:

	CRITICALITY FLIGHT HDW/FUNC	REDUNDANCY SCREENS			CIL ITEM
		A	B	C	
NASA	[ 3 /2R ]	[ P ]	[ P ]	[ P ]	[ ] *
IOA	[ 3 /2R ]	[ P ]	[ P ]	[ P ]	[ ]
COMPARE	[ / ]	[ ]	[ ]	[ ]	[ ]

RECOMMENDATIONS: (If different from NASA)

[ / ] [ ] [ ] [ ] [ ] (ADD/DELETE)

\* CIL RETENTION RATIONALE: (If applicable)

ADEQUATE [ ]  
 INADEQUATE [ ]

REMARKS:  
 NO DIFFERENCES.

APPENDIX C  
ASSESSMENT WORKSHEET

ASSESSMENT DATE: 10/10/86  
 ASSESSMENT ID: DPS-406  
 NASA FMEA #: 05-5-B04-2-1

NASA DATA:  
 BASELINE [ X ]  
 NEW [ ]

SUBSYSTEM: DPS  
 MDAC ID: 406  
 ITEM: Write electronics

LEAD ANALYST: K. Pietz

ASSESSMENT:

	CRITICALITY FLIGHT HDW/FUNC	REDUNDANCY SCREENS			CIL ITEM
		A	B	C	
NASA	[ 3 /2R ]	[ P ]	[ P ]	[ P ]	[ ] *
IOA	[ 3 /2R ]	[ P ]	[ P ]	[ P ]	[ ]
COMPARE	[ / ]	[ ]	[ ]	[ ]	[ ]

RECOMMENDATIONS: (If different from NASA)

[ / ] [ ] [ ] [ ] [ ]  
 (ADD/DELETE)

\* CIL RETENTION RATIONALE: (If applicable)

ADEQUATE [ ]  
 INADEQUATE [ ]

REMARKS:  
 NO DIFFERENCES.



APPENDIX C  
ASSESSMENT WORKSHEET

ASSESSMENT DATE: 10/10/86  
 ASSESSMENT ID: DPS-407  
 NASA FMEA #: 05-5-B04-2-1

NASA DATA:  
 BASELINE [ X ]  
 NEW [ ]

SUBSYSTEM: DPS  
 MDAC ID: 407  
 ITEM: RPC

LEAD ANALYST: K. Pietz

ASSESSMENT:

	CRITICALITY FLIGHT HDW/FUNC	REDUNDANCY SCREENS			CIL ITEM
		A	B	C	
NASA	[ 3 /2R ]	[ P ]	[ P ]	[ P ]	[ ] *
IOA	[ 3 /2R ]	[ P ]	[ P ]	[ P ]	[ ]
COMPARE	[ / ]	[ ]	[ ]	[ ]	[ ]

RECOMMENDATIONS: (If different from NASA)

[ / ] [ ] [ ] [ ] [ ]  
 (ADD/DELETE)

\* CIL RETENTION RATIONALE: (If applicable)

ADEQUATE [ ]  
 INADEQUATE [ ]

REMARKS:  
 NO DIFFERENCES.

APPENDIX C  
ASSESSMENT WORKSHEET

ASSESSMENT DATE: 10/10/86  
 ASSESSMENT ID: DPS-408  
 NASA FMEA #: 05-6S-BSW2-1

NASA DATA:  
 BASELINE [ X ]  
 NEW [ ]

SUBSYSTEM: DPS  
 MDAC ID: 408  
 ITEM: Switch

LEAD ANALYST: K. Pietz

ASSESSMENT:

	CRITICALITY FLIGHT HDW/FUNC	REDUNDANCY SCREENS			CIL ITEM
		A	B	C	
NASA	[ 3 /2R ]	[ P ]	[ P ]	[ P ]	[ ] *
IOA	[ 3 /2R ]	[ P ]	[ P ]	[ P ]	[ ]
COMPARE	[ / ]	[ ]	[ ]	[ ]	[ ]

RECOMMENDATIONS: (If different from NASA)

[ / ] [ ] [ ] [ ] [ ]  
 (ADD/DELETE)

\* CIL RETENTION RATIONALE: (If applicable)

ADEQUATE [ ]  
 INADEQUATE [ ]

REMARKS:  
 NO DIFFERENCES.

APPENDIX C  
ASSESSMENT WORKSHEET

ASSESSMENT DATE: 10/10/86  
 ASSESSMENT ID: DPS-409  
 NASA FMEA #: 05-6S-BSW2-2

NASA DATA:  
 BASELINE [ ]  
 NEW [ X ]

SUBSYSTEM: DPS  
 MDAC ID: 409  
 ITEM: Switch

LEAD ANALYST: K. Pietz

ASSESSMENT:

	CRITICALITY FLIGHT HDW/FUNC	REDUNDANCY SCREENS			CIL ITEM
		A	B	C	
NASA	[ 3 / 3 ]	[ P ]	[ P ]	[ P ]	[ ] *
IOA	[ 3 / 3 ]	[ NA ]	[ NA ]	[ NA ]	[ ]
COMPARE	[ / ]	[ N ]	[ N ]	[ N ]	[ ]

RECOMMENDATIONS: (If different from NASA)

[ / ] [ ] [ ] [ ] [ ] (ADD/DELETE)

\* CIL RETENTION RATIONALE: (If applicable)

ADEQUATE [ ]  
 INADEQUATE [ ]

REMARKS:

ACCORDING TO NSTS 22206, REDUNDANCY SCREENS MUST BE "NA" OR BLANK FOR FMEAS WITH A CRITICALITY OF 3/3.  
 NASA AGREED WITH THE IOA ASSESSMENT RECOMMENDATION.

APPENDIX C  
ASSESSMENT WORKSHEET

ASSESSMENT DATE: 10/14/86  
 ASSESSMENT ID: DPS-410  
 NASA FMEA #: 05-5-B04-2-1

NASA DATA:  
 BASELINE [ X ]  
 NEW [ ]

SUBSYSTEM: DPS  
 MDAC ID: 410  
 ITEM: Control logic

LEAD ANALYST: K. Pietz

ASSESSMENT:

	CRITICALITY FLIGHT HDW/FUNC	REDUNDANCY SCREENS			CIL ITEM
		A	B	C	
NASA	[ 3 /2R ]	[ P ]	[ P ]	[ P ]	[ ] *
IOA	[ 3 /2R ]	[ P ]	[ P ]	[ P ]	[ ]
COMPARE	[ / ]	[ ]	[ ]	[ ]	[ ]

RECOMMENDATIONS: (If different from NASA)

[ / ] [ ] [ ] [ ] [ ]  
 (ADD/DELETE)

\* CIL RETENTION RATIONALE: (If applicable)

ADEQUATE [ ]  
 INADEQUATE [ ]

REMARKS:  
 NO DIFFERENCES.

APPENDIX C  
ASSESSMENT WORKSHEET

ASSESSMENT DATE: 10/14/86  
 ASSESSMENT ID: DPS-411  
 NASA FMEA #: 05-5-B04-2-2

NASA DATA:  
 BASELINE [ X ]  
 NEW [ ]

SUBSYSTEM: DPS  
 MDAC ID: 411  
 ITEM: Control logic

LEAD ANALYST: K. Pietz

ASSESSMENT:

	CRITICALITY FLIGHT HDW/FUNC	REDUNDANCY SCREENS			CIL ITEM
		A	B	C	
NASA	[ 3 /2R ]	[ P ]	[ P ]	[ P ]	[ ] *
IOA	[ 3 /2R ]	[ P ]	[ P ]	[ P ]	[ ]
COMPARE	[ / ]	[ ]	[ ]	[ ]	[ ]

RECOMMENDATIONS: (If different from NASA)

[ / ] [ ] [ ] [ ] [ ]  
 (ADD/DELETE)

\* CIL RETENTION RATIONALE: (If applicable)

ADEQUATE [ ]  
 INADEQUATE [ ]

REMARKS:  
 NO DIFFERENCES.

APPENDIX C  
ASSESSMENT WORKSHEET

ASSESSMENT DATE: 10/14/86  
 ASSESSMENT ID: DPS-412  
 NASA FMEA #: 05-5-B04-2-1

NASA DATA:  
 BASELINE [ X ]  
 NEW [ ]

SUBSYSTEM: DPS  
 MDAC ID: 412  
 ITEM: Power supply

LEAD ANALYST: K. Pietz

ASSESSMENT:

	CRITICALITY FLIGHT HDW/FUNC	REDUNDANCY SCREENS			CIL ITEM
		A	B	C	
NASA	[ 3 /2R ]	[ P ]	[ P ]	[ P ]	[ ] *
IOA	[ 3 /2R ]	[ P ]	[ P ]	[ P ]	[ ]
COMPARE	[ / ]	[ ]	[ ]	[ ]	[ ]

RECOMMENDATIONS: (If different from NASA)

[ / ] [ ] [ ] [ ] [ ]  
 (ADD/DELETE)

\* CIL RETENTION RATIONALE: (If applicable)

ADEQUATE [ ]  
 INADEQUATE [ ]

REMARKS:

THIS FAILURE MODE, "FAILS OUT OF TOLERANCE", IS CONSIDERED TO BE COVERED BY THIS ROCKWELL FMEA WITH FAILURE MODE, "LOSS OF OUTPUT".

APPENDIX C  
ASSESSMENT WORKSHEET

ASSESSMENT DATE: 10/17/86  
ASSESSMENT ID: DPS-413  
NASA FMEA #: 05-6S-BRES2-1

NASA DATA:  
BASELINE [ X ]  
NEW [ ]

SUBSYSTEM: DPS  
MDAC ID: 413  
ITEM: RESISTOR, CURRENT LIMITER

LEAD ANALYST: B. ROBB

ASSESSMENT:

	CRITICALITY FLIGHT HDW/FUNC	REDUNDANCY SCREENS			CIL ITEM
		A	B	C	
NASA	[ 3 /2R ]	[ P ]	[ P ]	[ P ]	[ ] *
IOA	[ 3 /2R ]	[ P ]	[ P ]	[ P ]	[ ]
COMPARE	[ / ]	[ ]	[ ]	[ ]	[ ]

RECOMMENDATIONS: (If different from NASA)

[ / ] [ ] [ ] [ ] [ ]  
(ADD/DELETE)

\* CIL RETENTION RATIONALE: (If applicable)

ADEQUATE [ ]  
INADEQUATE [ ]

REMARKS:

NO DIFFERENCES. IOA DID NOT COVER THIS ITEM IN THE ORIGINAL ANALYSIS. THE EFFECTS OF THIS FAILED ITEM COULD BE CONSIDERED TO BE COVERED BY MDAC ID. 408, A SWITCH WHICH IS IN SERIES WITH THIS RESISTOR.

**APPENDIX C  
ASSESSMENT WORKSHEET**

ASSESSMENT DATE: 10/30/86  
 ASSESSMENT ID: DPS-414  
 NASA FMEA #: 05-6S-BRPC2-1

NASA DATA:  
 BASELINE [ X ]  
 NEW [ ]

SUBSYSTEM: DPS  
 MDAC ID: 414  
 ITEM: CONTROLLER, REMOTE POWER

LEAD ANALYST: H J LOWERY

**ASSESSMENT:**

	CRITICALITY FLIGHT HDW/FUNC	REDUNDANCY SCREENS			CIL ITEM
		A	B	C	
NASA	[ 3 /2R ]	[ P ]	[ P ]	[ P ]	[ ] *
IOA	[ 3 /2R ]	[ P ]	[ P ]	[ P ]	[ ]
COMPARE	[ / ]	[ ]	[ ]	[ ]	[ ]

**RECOMMENDATIONS: (If different from NASA)**

[ / ] [ ] [ ] [ ] [ ]  
 (ADD/DELETE)

**\* CIL RETENTION RATIONALE: (If applicable)**

ADEQUATE [ ]  
 INADEQUATE [ ]

**REMARKS:**

NO DIFFERENCES. IOA DID NOT COVER THIS FAILURE IN THE ORIGINAL ANALYSIS.



APPENDIX C  
ASSESSMENT WORKSHEET

ASSESSMENT DATE: 10/06/86  
 ASSESSMENT ID: DPS-415  
 NASA FMEA #: 05-5-B20-1-1

NASA DATA:  
 BASELINE [ X ]  
 NEW [ ]

SUBSYSTEM: DPS  
 MDAC ID: 415  
 ITEM: IPL Source Switch

LEAD ANALYST: T. B. Cribbs

ASSESSMENT:

	CRITICALITY FLIGHT HDW/FUNC	REDUNDANCY SCREENS			CIL ITEM
		A	B	C	
NASA	[ 2 / 2 ]	[ P ]	[ P ]	[ P ]	[ X ] *
IOA	[ 3 / 3 ]	[ NA ]	[ NA ]	[ NA ]	[ ]
COMPARE	[ N / N ]	[ N ]	[ N ]	[ N ]	[ N ]

RECOMMENDATIONS: (If different from NASA)

[ / ] [ ] [ ] [ ] [ ] (ADD/DELETE)

\* CIL RETENTION RATIONALE: (If applicable)

ADEQUATE [ X ]  
 INADEQUATE [ ]

REMARKS:

IOA CRITICALITY ASSIGNMENT WAS MADE BECAUSE AFTER INITIAL PROGRAM LOAD IS COMPLETE A SYSTEMS SOFTWARE PROBLEM OF SOME TYPE WOULD HAVE TO OCCUR BEFORE ANY ATTEMPT WOULD BE MADE TO RE-IPL A GIVEN GPC.

SIMULTANEOUS DISSIMILAR FAILURES WERE EXCLUDED FROM THE IOA.

MULTIPLE FAILURES ARE INCONSISTENT WITH NSTS 22206.

ACCORDING TO NSTS 22206, REDUNDANCY SCREENS MUST BE "NA" OR BLANK FOR FMEAS WITH A CRITICALITY OF 3/3.

IOA DOES CONCUR WITH NASA'S REEVALUATION AND RATIONALE.

APPENDIX C  
ASSESSMENT WORKSHEET

ASSESSMENT DATE: 11/10/86  
ASSESSMENT ID: DPS-416  
NASA FMEA #: MMU-1 (NEW)

NASA DATA:  
BASELINE [ ]  
NEW [ X ]

SUBSYSTEM: DPS  
MDAC ID: 416  
ITEM: CONTROLLER, REMOTE POWER

LEAD ANALYST: T. B. Cribbs

ASSESSMENT:

	CRITICALITY FLIGHT HDW/FUNC	REDUNDANCY SCREENS			CIL ITEM
		A	B	C	
NASA	[ 3 / 3 ]	[ NA ]	[ NA ]	[ NA ]	[ ] *
IOA	[ 3 / 3 ]	[ NA ]	[ NA ]	[ NA ]	[ ]
COMPARE	[ / ]	[ ]	[ ]	[ ]	[ ]

RECOMMENDATIONS: (If different from NASA)

[ / ] [ ] [ ] [ ] [ ] (ADD/DELETE)

\* CIL RETENTION RATIONALE: (If applicable)

ADEQUATE [ ]  
INADEQUATE [ ]

REMARKS:

IOA DID NOT COVER THIS FAILURE MODE IN THE ORIGINAL ANALYSIS.  
ACCORDING TO NSTS 22206, REDUNDANCY SCREENS MUST BE "NA" OR BLANK  
FOR FMEAS WITH A CRITICALITY OF 3/3.  
NASA AGREED WITH THE IOA ASSESSMENT RECOMMENDATION.

APPENDIX C  
ASSESSMENT WORKSHEET

ASSESSMENT DATE: 11/10/86  
 ASSESSMENT ID: DPS-417  
 NASA FMEA #: MMU-2 (NEW)

NASA DATA:  
 BASELINE [    ]  
 NEW [ X ]

SUBSYSTEM: DPS  
 MDAC ID: 417  
 ITEM: SWITCH, IPL

LEAD ANALYST: H J LOWERY

ASSESSMENT:

	CRITICALITY FLIGHT HDW/FUNC	REDUNDANCY SCREENS			CIL ITEM
		A	B	C	
NASA	[ 3 /2R ]	[ P ]	[ P ]	[ P ]	[    ] *
IOA	[ 3 /2R ]	[ P ]	[ P ]	[ P ]	[    ]
COMPARE	[ / ]	[    ]	[    ]	[    ]	[    ]

RECOMMENDATIONS: (If different from NASA)

[ / ] [    ] [    ] [    ] [    ]  
 (ADD/DELETE)

\* CIL RETENTION RATIONALE: (If applicable)

ADEQUATE [    ]  
 INADEQUATE [    ]

REMARKS:

REF. 05-5-B16-1-1. NASA-JSC FMEA & CIL REVIEW COMMENTS, 9-19-86.  
 IOA DID NOT COVER THIS ITEM IN THE ORIGINAL ANALYSIS.  
 NASA AGREED WITH THE IOA ASSESSMENT RECOMMENDATION.

APPENDIX C  
ASSESSMENT WORKSHEET

ASSESSMENT DATE: 10/14/86  
 ASSESSMENT ID: DPS-501  
 NASA FMEA #: 05-5-B08-1-1

NASA DATA:  
 BASELINE [ ]  
 NEW [ X ]

SUBSYSTEM: DPS  
 MDAC ID: 501  
 ITEM: CIA

LEAD ANALYST: B. ROBB

ASSESSMENT:

	CRITICALITY FLIGHT HDW/FUNC	REDUNDANCY SCREENS			CIL ITEM
		A	B	C	
NASA	[ 2 /1R ]	[ P ]	[ F ]	[ P ]	[ X ] *
IOA	[ 3 /1R ]	[ P ]	[ P ]	[ P ]	[ ]
COMPARE	[ N / ]	[ ]	[ N ]	[ ]	[ N ]

RECOMMENDATIONS: (If different from NASA)

[ / ] [ ] [ ] [ ] [ ]  
 (ADD/DELETE)

\* CIL RETENTION RATIONALE: (If applicable)

ADEQUATE [ ]  
 INADEQUATE [ X ]

REMARKS:

THIS FAILURE MODE, "LOSS OF OUTPUT TO MAIN ENGINE ON ONE CHANNEL", COULD BE CONSIDERED TO BE COVERED BY ROCKWELL 05-05-B08-1-1 WITH FAILURE MODE, "NO OUTPUT".  
 IOA DOES CONCUR WITH NASA'S REEVALUATION. THE CIL RETENTION RATIONALE IS INADEQUATE BECAUSE IT IS NOT YET AVAILABLE.

APPENDIX C  
ASSESSMENT WORKSHEET

ASSESSMENT DATE: 10/14/86  
 ASSESSMENT ID: DPS-502  
 NASA FMEA #: 05-5-B08-1-1

NASA DATA:  
 BASELINE [ ]  
 NEW [ X ]

SUBSYSTEM: DPS  
 MDAC ID: 502  
 ITEM: MIA

LEAD ANALYST: B. ROBB

ASSESSMENT:

	CRITICALITY - FLIGHT HDW/FUNC	REDUNDANCY SCREENS			CIL ITEM
		A	B	C	
NASA	[ 2 /1R ]	[ P ]	[ F ]	[ P ]	[ X ] *
IOA	[ 3 /1R ]	[ P ]	[ P ]	[ P ]	[ ]
COMPARE	[ N / ]	[ ]	[ N ]	[ ]	[ N ]

RECOMMENDATIONS: (If different from NASA)

[ / ] [ ] [ ] [ ] [ ]  
 (ADD/DELETE)

\* CIL RETENTION RATIONALE: (If applicable)

ADEQUATE [ ]  
 INADEQUATE [ X ]

REMARKS:

IOA DOES CONCUR WITH NASA'S REEVALUATION. THE CIL RETENTION RATIONALE IS INADEQUATE BECAUSE IT IS NOT YET AVIALABLE.

APPENDIX C  
ASSESSMENT WORKSHEET

ASSESSMENT DATE: 10/14/86  
 ASSESSMENT ID: DPS-503  
 NASA FMEA #: 05-5-B08-1-1

NASA DATA:  
 BASELINE [ ]  
 NEW [ X ]

SUBSYSTEM: DPS  
 MDAC ID: 503  
 ITEM: POWER CONTROL SWITCH

LEAD ANALYST: B. ROBB

ASSESSMENT:

	CRITICALITY FLIGHT HDW/FUNC	REDUNDANCY SCREENS			CIL ITEM
		A	B	C	
NASA	[ 2 / 1R ]	[ P ]	[ F ]	[ P ]	[ ] *
IOA	[ 3 / 1R ]	[ P ]	[ P ]	[ P ]	[ ]
COMPARE	[ N / ]	[ ]	[ N ]	[ ]	[ ]

RECOMMENDATIONS: (If different from NASA)

[ / ] [ ] [ ] [ ] [ ]  
 (ADD/DELETE)

\* CIL RETENTION RATIONALE: (If applicable)

ADEQUATE [ ]  
 INADEQUATE [ X ]

REMARKS:

THIS FAILURE MODE, "LOSS OF OUTPUT TO MAIN ENGINE ON ALL COMMAND CHANNELS", IS CONSIDERED TO BE COVERED BY ROCKWELL 05-5-B08-1-1 WITH THIS FAILURE "LOSS OF REDUNDANT POWER SUPPLIES". IOA DOES CONCUR WITH NASA'S REEVALUATION. THE CIL RETENTION RATIONALE IS INADEQUATE BECAUSE IT IS NOT YET AVIALBLE.

APPENDIX C  
ASSESSMENT WORKSHEET

ASSESSMENT DATE: 10/14/86  
 ASSESSMENT ID: DPS-504  
 NASA FMEA #: 05-5-B08-1-1

NASA DATA:  
 BASELINE [ ]  
 NEW [ X ]

SUBSYSTEM: DPS  
 MDAC ID: 504  
 ITEM: INTERNAL POWER SUPPLIES

LEAD ANALYST: B. ROBB

ASSESSMENT:

	CRITICALITY FLIGHT HDW/FUNC	REDUNDANCY SCREENS			CIL ITEM
		A	B	C	
NASA	[ 2 /1R ]	[ P ]	[ F ]	[ P ]	[ X ] *
IOA	[ 3 /1R ]	[ P ]	[ P ]	[ P ]	[ ]
COMPARE	[ N / ]	[ ]	[ N ]	[ ]	[ N ]

RECOMMENDATIONS: (If different from NASA)

[ / ] [ ] [ ] [ ] [ ]  
 (ADD/DELETE)

\* CIL RETENTION RATIONALE: (If applicable)

ADEQUATE [ ]  
 INADEQUATE [ X ]

REMARKS:

THIS FAILURE MODE, "LOSS OF OUTPUT TO MAIN ENGINE ON ALL COMMAND CHANNELS", IS CONSIDERED TO BE COVERED BY ROCKWELL 05-5-B08-1-1, WITH THIS FAILURE "LOSS OF REDUNDANT POWER SUPPLIES".  
 IOA DOES CONCUR WITH NASA'S REEVALUATION.  
 THE CIL RETENTION RATIONALE IS INADEQUATE BECAUSE IT IS NOT YET AVAILABLE.

**APPENDIX C  
ASSESSMENT WORKSHEET**

ASSESSMENT DATE: 10/14/86  
 ASSESSMENT ID: DPS-505  
 NASA FMEA #: 05-5-B08-1-1

NASA DATA:  
 BASELINE [ ]  
 NEW [ X ]

SUBSYSTEM: DPS  
 MDAC ID: 505  
 ITEM: CONTROLLER INTERFACE ADAPTER

LEAD ANALYST: B. ROBB

**ASSESSMENT:**

	CRITICALITY FLIGHT HDW/FUNC	REDUNDANCY SCREENS			CIL ITEM
		A	B	C	
NASA	[ 2 /1R ]	[ P ]	[ F ]	[ P ]	[ X ] *
IOA	[ 3 /1R ]	[ P ]	[ P ]	[ P ]	[ ]
COMPARE	[ N / ]	[ ]	[ N ]	[ ]	[ N ]

RECOMMENDATIONS: (If different from NASA)

[ / ] [ ] [ ] [ ] [ ] (ADD/DELETE)

\* CIL RETENTION RATIONALE: (If applicable)

ADEQUATE [ ]  
 INADEQUATE [ X ]

**REMARKS:**

THIS FAILURE MODE, "LOSS OF OUTPUT ON STATUS OF ENGINES", IS CONSIDERED TO BE COVERED BY ROCKWELL 05-5-B08-1-1, WITH THIS FAILURE MODE "NO OUTPUT".  
 IOA DOES CONCUR WITH NASA'S REEVALUATION.  
 THE CIL RETENTION RATIONALE IS INADEQUATE BECAUSE IT IS NOT YET AVAILABLE.



APPENDIX C  
ASSESSMENT WORKSHEET

ASSESSMENT DATE: 10/14/86  
 ASSESSMENT ID: DPS-506  
 NASA FMEA #: 05-5-B08-1-1

NASA DATA:  
 BASELINE [ X ]  
 NEW [ ]

SUBSYSTEM: DPS  
 MDAC ID: 506  
 ITEM: OIE

LEAD ANALYST: B. ROBB

ASSESSMENT:

	CRITICALITY FLIGHT HDW/FUNC	REDUNDANCY SCREENS			CIL ITEM
		A	B	C	
NASA	[ 2 /1R ]	[ P ]	[ F ]	[ P ]	[ ] *
IOA	[ 3 /3 ]	[ NA ]	[ NA ]	[ NA ]	[ ]
COMPARE	[ N /N ]	[ N ]	[ N ]	[ N ]	[ ]

RECOMMENDATIONS: (If different from NASA)

[ / ] [ ] [ ] [ ] [ ] (ADD/DELETE)

\* CIL RETENTION RATIONALE: (If applicable)

ADEQUATE [ ]  
 INADEQUATE [ ]

REMARKS:

NASA/RI DID NOT SPECIFICALLY COVER THIS FAILURE MODE, "LOSS OF OUTPUT TO S-BAND, MAINTENANCE RECORDS, AND LPS T-O UMBILICAL". THIS FAILURE MODE IS CONSIDERED TO BE COVERED BY ROCKWELL FMEA 05-5-B08-1-1, WITH FAILURE MODE "NO OUTPUT".

APPENDIX C  
ASSESSMENT WORKSHEET

ASSESSMENT DATE: 10/16/86  
 ASSESSMENT ID: DPS-507  
 NASA FMEA #: 05-6S-BCKT1-1

NASA DATA:  
 BASELINE [ ]  
 NEW [ X ]

SUBSYSTEM: DPS  
 MDAC ID: 507  
 ITEM: CIRCUIT, EIU POWER

LEAD ANALYST: B. ROBB

ASSESSMENT:

	CRITICALITY	REDUNDANCY SCREENS			CIL
	FLIGHT HDW/FUNC	A	B	C	ITEM
NASA	[ 2 /1R ]	[ P ]	[ F ]	[ P ]	[ X ] *
IOA	[ 2 /1R ]	[ P ]	[ F ]	[ P ]	[ X ]
COMPARE	[ / ]	[ ]	[ ]	[ ]	[ ]

RECOMMENDATIONS: (If different from NASA)

[ / ] [ ] [ ] [ ] [ ]  
 (ADD/DELETE)

\* CIL RETENTION RATIONALE: (If applicable)

ADEQUATE [ ]  
 INADEQUATE [ X ]

REMARKS:

NO DIFFERENCES. IOA DID NOT COVER THIS ITEM IN ORIGINAL ANALYSIS. IOA DOES CONCUR WITH THE NASA REEVALUATION. THE CIL RETENTION RATIONALE IS INADEQUATE BECAUSE IT IS NOT YET AVAILABLE.

APPENDIX C  
ASSESSMENT WORKSHEET

ASSESSMENT DATE: 11/03/86  
 ASSESSMENT ID: DPS-508  
 NASA FMEA #: EIU-1 (NEW)

NASA DATA:  
 BASELINE [    ]  
 NEW [ X ]

SUBSYSTEM: DPS  
 MDAC ID: 508  
 ITEM: EIU

LEAD ANALYST: H J LOWERY

ASSESSMENT:

	CRITICALITY FLIGHT HDW/FUNC	REDUNDANCY SCREENS			CIL ITEM
		A	B	C	
NASA	[ 1 / 1 ]	[ P ]	[ F ]	[ P ]	[ X ] *
IOA	[ 1 / 1 ]	[ P ]	[ F ]	[ P ]	[ X ]
COMPARE	[ / ]	[ ]	[ ]	[ ]	[ ]

RECOMMENDATIONS: (If different from NASA)

[ / ] [ ] [ ] [ ] [ ]  
 (ADD/DELETE)

\* CIL RETENTION RATIONALE: (If applicable)

ADEQUATE [    ]  
 INADEQUATE [ X ]

REMARKS:

IOA DID NOT COVER THIS FAILURE MODE IN THE ORIGINAL ANALYSIS.  
 NASA AGREED WITH THE IOA ASSESSMENT RECOMMENDATION.  
 THE RETENTION RATIONALE IS INADEQUATE BECAUSE IT IS NOT YET  
 AVAILABLE. THIS IS A NEW FMEA PRESENTED AT THE DPS PREBOARD.

APPENDIX C  
ASSESSMENT WORKSHEET

ASSESSMENT DATE: 11/03/86  
ASSESSMENT ID: DPS-509  
NASA FMEA #: EIU-2 (NEW)

NASA DATA:  
BASELINE [   ]  
NEW [ X ]

SUBSYSTEM: DPS  
MDAC ID: 509  
ITEM: SWITCH, POWER

LEAD ANALYST: H J LOWERY

ASSESSMENT:

	CRITICALITY FLIGHT HDW/FUNC	REDUNDANCY SCREENS			CIL ITEM
		A	B	C	
NASA	[ 1 / 1 ]	[ P ]	[ F ]	[ P ]	[ X ] *
IOA	[ 1 / 1 ]	[ P ]	[ F ]	[ P ]	[ X ]
COMPARE	[   /   ]	[   ]	[   ]	[   ]	[   ]

RECOMMENDATIONS: (If different from NASA)

[   /   ]   [   ]   [   ]   [   ]   [   ]  
(ADD/DELETE)

\* CIL RETENTION RATIONALE: (If applicable)

ADEQUATE [   ]  
INADEQUATE [ X ]

REMARKS:

IOA DID NOT COVER THIS FAILURE MODE IN THE ORIGINAL ANALYSIS.  
NASA AGREED WITH THE IOA ASSESSMENT RECOMMENDATION.  
THE CIL RETENTION RATIONALE IS INADEQUATE BECAUSE IT IS NOT YET  
AVAILABLE. THIS IS A NEW FMEA PRESENTED AT THE DPS PREBOARD.

APPENDIX D

CRITICAL ITEMS

APPENDIX D  
CRITICAL ITEMS

NASA FMEA	IOA ID	ITEM NAME	FAILURE MODE
MDM			
* 05-5 -B03-1-1	120	FA MDM	LOSS OF OUTPUT
05-5 -B03-1-2	122	FA MDM	LOSS OF OUTPUT
* 05-5 -B03-2-1	108	FF MDM	LOSS OF OUTPUT
05-5 -B03-2-2	107	FF MDM	LOSS OF OUTPUT
05-5 -B03-5-1	141	PF MDM	LOSS OF OUTPUT
05-5 -B03-5-2	142	PF MDM	LOSS OF OUTPUT
% 05-6S-BRES3-1	190	RESISTOR	OPEN
% 05-6S-BRPC3-1	191	RPC	LOSS OF OUTPUT
% 05-6S-BSW3 -1	193	SWITCH	PREMATURE OPERATION
% 05-6S-BSW5 -3	195	SWITCH	FAILS-TO-TRANSFER
GPC			
* 05-5 -B01-1-1	205	CPU	LOSS OF OUTPUT
* 05-5 -B02-1-1	201	IOP	LOSS OF OUTPUT
05-5 -B02-1-3	225	IOP	ERRONEOUS OUTPUT
% 05-5 -B17-1-1	210	SWITCH	LOSS OF OUTPUT
% 05-6S-BDIOX-1	230	DIODE	FAILS OPEN
% 05-6S-BSW1 -3	217	SWITCH	FAILS OPEN
MCDS			
05-5-B22-1-1	300	SWITCH	ERRONEOUS OUTPUT
05-5-B23-1-3	307	KBD ADAPTER	ERRONEOUS OUTPUT
% 05-5-B24-1-1	300	SWITCH	FAILS OPEN
DBC			
05-5-B14-1-1	315	DBC	FAILS OPEN/SHORT
MMU			
05-5-B20-1-1	415	SWITCH	FAILS-TO-TRANSFER
EIU			
% EIU-1	508	EIU	ERRONEOUS OUTPUT
% EIU-2	509	SWITCH	SHORT-TO-GROUND
% 05-5 -B08-1-1	501	CIA	NO OUTPUT
% 05-6S-BCKT1-1	507	POWER CKT	FAILS OPEN/SHORT

NOTE \* IOA ISSUE  
% ADDED TO CIL POST 51-L

APPENDIX E  
DETAILED ANALYSIS

This section contains the IOA analysis worksheets generated during the analysis of this subsystem. The information on these worksheets is intentionally similar to the NASA FMEAs. Each of these sheets identifies the hardware item being analyzed, and parent assembly, as well as the function. For each failure mode, the possible causes are outlined, and the assessed hardware and functional criticality for each mission phase is listed, as described in the NSTS 22206, Instructions for Preparation of FMEA and CIL, 10 October 1986. Finally, effects are entered at the bottom of each sheet, and the worst case criticality is entered at the top.

LEGEND FOR IOA ANALYSIS WORKSHEETS  
-----

Hardware Criticalities:

- 1 = Loss of life or vehicle
- 2 = Loss of mission or next failure of any redundant item (like or unlike) could cause loss of life/vehicle
- 3 = All others

Functional Criticalities:

- 1R = Redundant hardware items (like or unlike) all of which, if failed, could cause loss of life or vehicle.
- 2R = Redundant hardware items (like or unlike) all of which, if failed, could cause loss of mission.

Redundancy Screen A:

- 1 = Is Checked Out PreFlight
- 2 = Is Capable of Check Out PreFlight
- 3 = Not Capable of Check Out PreFlight
- NA = Not Applicable

Redundancy Screens B and C:

- P = Passed Screen
- F = Failed Screen
- NA = Not Applicable

INDEPENDENT ORBITER ASSESSMENT  
ORBITER SUBSYSTEM ANALYSIS WORKSHEET

DATE: 10/03/86 HIGHEST CRITICALITY HDW/FUNC  
SUBSYSTEM: DPS FLIGHT: 3/1R  
MDAC ID: 100 ABORT: 3/1R

ITEM: MDM FF1,FF2,FF3,FF4  
FAILURE MODE: Loss of Output to GPC

LEAD ANALYST: W. A. Haufler SUBSYS LEAD: B. Robb

BREAKDOWN HIERARCHY:

- 1) DPS
- 2) Multiplexer-DeMultiplexers (MDM)
- 3) Flight critical Forward MDM (FF1..4)
- 4)
- 5)
- 6)
- 7)
- 8)
- 9)

FLIGHT PHASE	CRITICALITIES		HDW/FUNC
	HDW/FUNC	ABORT	
PRELAUNCH:	3/2R	RTL5:	3/1R
LIFTOFF:	3/1R	TAL:	3/1R
ONORBIT:	3/2R	AOA:	3/1R
DEORBIT:	3/1R	ATO:	3/1R
LANDING/SAFING:	3/1R		

REDUNDANCY SCREENS: A [ 1 ] B [ P ] C [ P ]

LOCATION: Av Bay 1,2,3,2  
PART NUMBER: MC615-0004-6110,5110

CAUSES: Vibration, Corrosion, Contamination

EFFECTS/RATIONALE:

FCOS sets Commfault flag for that data. Application SW ignores that data. FCOS bypasses MDM after 2nd consecutive commfault, and displays fault msg on CRTs. Port moding may recover MDM, but not allowed during ascent until after 2nd MDM failure. If all redundancy fails, lose use of IMU torquing, forward RCS jets, Hand Controls (THC,RHC), most switches and indicators.

REFERENCES:



INDEPENDENT ORBITER ASSESSMENT  
ORBITER SUBSYSTEM ANALYSIS WORKSHEET

DATE:	10/03/86	HIGHEST CRITICALITY	HDW/FUNC
SUBSYSTEM:	DPS	FLIGHT:	3/1R
MDAC ID:	101	ABORT:	3/1R

ITEM: MDM FF1,FF2,FF3,FF4  
FAILURE MODE: Loss of Output to LRU

LEAD ANALYST: W. A. Haufler                      SUBSYS LEAD: B. Robb

BREAKDOWN HIERARCHY:

- 1) DPS
- 2) Multiplexer-DeMultiplexers (MDM)
- 3) Flight critical Forward MDM (FF1..4)
- 4)
- 5)
- 6)
- 7)
- 8)
- 9)

FLIGHT PHASE	CRITICALITIES		
	HDW/FUNC	ABORT	HDW/FUNC
PRELAUNCH:	3/2R	RTLS:	3/1R
LIFTOFF:	3/1R	TAL:	3/1R
ONORBIT:	3/2R	AOA:	3/1R
DEORBIT:	3/1R	ATO:	3/1R
LANDING/SAFING:	3/1R		

REDUNDANCY SCREENS:    A [ 1 ]                      B [ P ]                      C [ P ]

LOCATION:                      Av Bay 1,2,3,2  
PART NUMBER:                MC615-0004-6110,5110

CAUSES:    Vibration, Corrosion, Contamination

EFFECTS/RATIONALE:

FCOS does not directly detect this error via MDM Return Word processing. Fault tolerance depends on redundant strings to voting LRUs. Detection depends on separate, redundant feedback signals.

If all redundancy fails, lose use of IMU torquing, forward RCS jets, Hand Controls (THC,RHC), most switches and indicators.

REFERENCES:

INDEPENDENT ORBITER ASSESSMENT  
ORBITER SUBSYSTEM ANALYSIS WORKSHEET

DATE: 10/03/86 HIGHEST CRITICALITY HDW/FUNC  
SUBSYSTEM: DPS FLIGHT: 3/1R  
MDAC ID: 102 ABORT: 3/1R

ITEM: MDM FF1,FF2,FF3,FF4  
FAILURE MODE: Erroneous Output to GPC

LEAD ANALYST: W. A. Haufler SUBSYS LEAD: B. Robb

BREAKDOWN HIERARCHY:

- 1) DPS
- 2) Multiplexer-DeMultiplexers (MDM)
- 3) Flight critical Forward MDM (FF1..4)
- 4)
- 5)
- 6)
- 7)
- 8)
- 9)

CRITICALITIES			
FLIGHT PHASE	HDW/FUNC	ABORT	HDW/FUNC
PRELAUNCH:	3/2R	RTLS:	3/1R
LIFTOFF:	3/1R	TAL:	3/1R
ONORBIT:	3/2R	AOA:	3/1R
DEORBIT:	3/1R	ATO:	3/1R
LANDING/SAFING:	3/1R		

REDUNDANCY SCREENS: A [ 1 ] B [ P ] C [ P ]

LOCATION: Av Bay 1,2,3,2  
PART NUMBER: MC615-0004-6110,5110

CAUSES: Vibration, Corrosion, Contamination

EFFECTS/RATIONALE:

FCOS sets Commfault flag for that data. Application SW ignores that data. FCOS bypasses MDM after 2nd consecutive commfault, and displays fault msg on CRTs. Port moding may recover MDM, but not allowed during ascent until after 2nd MDM failure. If all redundancy fails, lose use of IMU torquing, forward RCS jets, Hand Controls (THC,RHC), most switches and indicators.

REFERENCES:

INDEPENDENT ORBITER ASSESSMENT  
ORBITER SUBSYSTEM ANALYSIS WORKSHEET

DATE: 10/03/86 HIGHEST CRITICALITY HDW/FUNC  
SUBSYSTEM: DPS FLIGHT: 3/1R  
MDAC ID: 103 ABORT: 3/1R

ITEM: MDM FF1,FF2,FF3,FF4  
FAILURE MODE: Erroneous Output to LRU

LEAD ANALYST: W. A. Haufler SUBSYS LEAD: B. Robb

BREAKDOWN HIERARCHY:

- 1) DPS
- 2) Multiplexer-DeMultiplexers (MDM)
- 3) Flight critical Forward MDM (FF1..4)
- 4)
- 5)
- 6)
- 7)
- 8)
- 9)

CRITICALITIES			
FLIGHT PHASE	HDW/FUNC	ABORT	HDW/FUNC
PRELAUNCH:	3/2R	RTLS:	3/1R
LIFTOFF:	3/1R	TAL:	3/1R
ONORBIT:	3/2R	AOA:	3/1R
DEORBIT:	3/1R	ATO:	3/1R
LANDING/SAFING:	3/1R		

REDUNDANCY SCREENS: A [ 1 ] B [ P ] C [ P ]

LOCATION: Av Bay 1,2,3,2  
PART NUMBER: MC615-0004-6110,5110

CAUSES: Vibration, Corrosion, Contamination

EFFECTS/RATIONALE:

FCOS does not directly detect this error via MDM Return Word processing. Fault tolerance depends on redundant strings to voting LRUs. Detection depends on separate, redundant feedback signals.

If all redundancy fails, lose use of IMU torquing, forward RCS jets, Hand Controls (THC,RHC), most switches and indicators.

REFERENCES:

INDEPENDENT ORBITER ASSESSMENT  
ORBITER SUBSYSTEM ANALYSIS WORKSHEET

DATE: 10/03/86 HIGHEST CRITICALITY HDW/FUNC  
SUBSYSTEM: DPS FLIGHT: 3/1R  
MDAC ID: 104 ABORT: 3/1R

ITEM: MDM FF1,FF2,FF3,FF4  
FAILURE MODE: Premature Operation to GPC

LEAD ANALYST: W. A. Haufler SUBSYS LEAD: B. Robb

BREAKDOWN HIERARCHY:

- 1) DPS
- 2) Multiplexer-DeMultiplexers (MDM)
- 3) Flight critical Forward MDM (FF1..4)
- 4)
- 5)
- 6)
- 7)
- 8)
- 9)

FLIGHT PHASE	CRITICALITIES		HDW/FUNC
	HDW/FUNC	ABORT	
PRELAUNCH:	3/2R	RTLS:	3/1R
LIFTOFF:	3/1R	TAL:	3/1R
ONORBIT:	3/2R	AOA:	3/1R
DEORBIT:	3/1R	ATO:	3/1R
LANDING/SAFING:	3/1R		

REDUNDANCY SCREENS: A [ 1 ] B [ P ] C [ P ]

LOCATION: Av Bay 1,2,3,2  
PART NUMBER: MC615-0004-6110,5110

CAUSES: Vibration, Corrosion, Contamination

EFFECTS/RATIONALE:

This failure on either port can interfere with FCOS returning data from other BTU(s) and cause healthy BTU(s) to be bypassed. Port moding will not fix a blabbing MDM. Power cycling may reset electronics, but cannot be performed during ascent (power switches cannot be reached), and will not always stop premature operations. If all redundancy fails, lose use of IMU torquing, forward RCS jets, Hand Controls (THC,RHC), most switches and indicators.

REFERENCES:

INDEPENDENT ORBITER ASSESSMENT  
ORBITER SUBSYSTEM ANALYSIS WORKSHEET

DATE: 10/03/86 HIGHEST CRITICALITY HDW/FUNC  
SUBSYSTEM: DPS FLIGHT: 3/1R  
MDAC ID: 105 ABORT: 3/1R

ITEM: MDM FF1,FF2,FF3,FF4  
FAILURE MODE: Premature Operation to LRU

LEAD ANALYST: W. A. Haufler SUBSYS LEAD: B. Robb

BREAKDOWN HIERARCHY:

- 1) DPS
- 2) Multiplexer-DeMultiplexers (MDM)
- 3) Flight critical Forward MDM (FF1..4)
- 4)
- 5)
- 6)
- 7)
- 8)
- 9)

CRITICALITIES			
FLIGHT PHASE	HDW/FUNC	ABORT	HDW/FUNC
PRELAUNCH:	3/2R	RTLS:	3/1R
LIFTOFF:	3/1R	TAL:	3/1R
ONORBIT:	3/2R	AOA:	3/1R
DEORBIT:	3/1R	ATO:	3/1R
LANDING/SAFING:	3/1R		

REDUNDANCY SCREENS: A [ 1 ] B [ P ] C [ P ]

LOCATION: Av Bay 1,2,3,2  
PART NUMBER: MC615-0004-6110,5110

CAUSES: Vibration, Corrosion, Contamination

EFFECTS/RATIONALE:

FCOS does not directly detect this error via MDM Return Word processing. Fault tolerance depends on redundant strings to voting LRUs. Detection depends on separate, redundant feedback signals.

If all redundancy fails, lose use of IMU torquing, forward RCS jets, Hand Controls (THC,RHC), most switches and indicators.

REFERENCES:

INDEPENDENT ORBITER ASSESSMENT  
ORBITER SUBSYSTEM ANALYSIS WORKSHEET

DATE: 10/03/86 HIGHEST CRITICALITY HDW/FUNC  
SUBSYSTEM: DPS FLIGHT: 3/1R  
MDAC ID: 106 ABORT: 3/1R

ITEM: MDM FF1,FF2,FF3,FF4  
FAILURE MODE: Selected All Channels Wrong

LEAD ANALYST: W. A. Haufler SUBSYS LEAD: B. Robb

BREAKDOWN HIERARCHY:

- 1) DPS
- 2) Multiplexer-DeMultiplexers (MDM)
- 3) Flight critical Forward MDM (FF1..4)
- 4)
- 5)
- 6)
- 7)
- 8)
- 9)

CRITICALITIES			
FLIGHT PHASE	HDW/FUNC	ABORT	HDW/FUNC
PRELAUNCH:	3/2R	RTLS:	3/1R
LIFTOFF:	3/1R	TAL:	3/1R
ONORBIT:	3/2R	AOA:	3/1R
DEORBIT:	3/1R	ATO:	3/1R
LANDING/SAFING:	3/1R		

REDUNDANCY SCREENS: A [ 1 ] B [ P ] C [ P ]

LOCATION: Av Bay 1,2,3,2  
PART NUMBER: MC615-0004-6110,5110

CAUSES: Vibration, Corrosion, Contamination

EFFECTS/RATIONALE:

The GPC's FCOS and the LRUs would reject all data from that MDM except any data that happened to be in the same format as the expected data. Redundancy Mgt. soon detects and bypasses that MDM, and the effects of wrong data input or output is minimized. If all redundancy fails, lose use of IMU torquing, forward RCS jets, Hand Controls (THC,RHC), most switches and indicators.

REFERENCES:

INDEPENDENT ORBITER ASSESSMENT  
ORBITER SUBSYSTEM ANALYSIS WORKSHEET

DATE:	10/03/86	HIGHEST CRITICALITY	HDW/FUNC
SUBSYSTEM:	DPS	FLIGHT:	3/1R
MDAC ID:	107	ABORT:	3/1R

ITEM: MDM FF1,FF2,FF3,FF4  
FAILURE MODE: Stuck on a Constant Output to LRU

LEAD ANALYST: W. A. Haufler                      SUBSYS LEAD: B. Robb

BREAKDOWN HIERARCHY:

- 1) DPS
- 2) Multiplexer-DeMultiplexers (MDM)
- 3) Flight critical Forward MDM (FF1..4)
- 4)
- 5)
- 6)
- 7)
- 8)
- 9)

FLIGHT PHASE	CRITICALITIES		
	HDW/FUNC	ABORT	HDW/FUNC
PRELAUNCH:	3/2R	RTLS:	3/1R
LIFTOFF:	3/1R	TAL:	3/1R
ONORBIT:	3/2R	AOA:	3/1R
DEORBIT:	3/1R	ATO:	3/1R
LANDING/SAFING:	3/1R		

REDUNDANCY SCREENS:    A [ 1 ]                      B [ P ]                      C [ P ]

LOCATION:                      Av Bay 1,2,3,2  
PART NUMBER:                MC615-0004-6110,5110

CAUSES:    Vibration, Corrosion, Contamination

EFFECTS/RATIONALE:

FCOS does not directly detect this error via MDM Return Word processing. Fault tolerance depends on redundant strings to voting LRUs. Detection depends on separate, redundant feedback signals.

If all redundancy fails, lose use of IMU torquing, forward RCS jets, Hand Controls (THC,RHC), most switches and indicators.

REFERENCES:

INDEPENDENT ORBITER ASSESSMENT  
ORBITER SUBSYSTEM ANALYSIS WORKSHEET

DATE: 10/03/86 HIGHEST CRITICALITY HDW/FUNC  
SUBSYSTEM: DPS FLIGHT: 3/1R  
MDAC ID: 108 ABORT: 3/1R

ITEM: MDM FF1,FF2,FF3,FF4  
FAILURE MODE: Falsely Stuck on Busy Mode

LEAD ANALYST: W. A. Haufler SUBSYS LEAD: B. Robb

BREAKDOWN HIERARCHY:

- 1) DPS
- 2) Multiplexer-DeMultiplexers (MDM)
- 3) Flight critical Forward MDM (FF1..4)
- 4)
- 5)
- 6)
- 7)
- 8)
- 9)

CRITICALITIES			
FLIGHT PHASE	HDW/FUNC	ABORT	HDW/FUNC
PRELAUNCH:	3/2R	RTLS:	3/1R
LIFTOFF:	3/1R	TAL:	3/1R
ONORBIT:	3/2R	AOA:	3/1R
DEORBIT:	3/1R	ATO:	3/1R
LANDING/SAFING:	3/1R		

REDUNDANCY SCREENS: A [ 1 ] B [ P ] C [ P ]

LOCATION: Av Bay 1,2,3,2  
PART NUMBER: MC615-0004-6110,5110

CAUSES: Vibration, Corrosion, Contamination, SCU Busy Cross-strap stuck high

EFFECTS/RATIONALE:

FCOS sets Commfault flag for that data. Application SW ignores that data. FCOS bypasses MDM after 2nd consecutive commfault, and displays fault msg on CRTs. Port moding may recover MDM, but not allowed during ascent until after 2nd MDM failure. If all redundancy fails, lose use of IMU torquing, forward RCS jets, Hand Controls (THC,RHC), most switches and indicators.

REFERENCES:



INDEPENDENT ORBITER ASSESSMENT  
ORBITER SUBSYSTEM ANALYSIS WORKSHEET

DATE: 10/03/86 HIGHEST CRITICALITY HDW/FUNC  
 SUBSYSTEM: DPS FLIGHT: 3/1R  
 MDAC ID: 120 ABORT: 3/1R

ITEM: MDM FA1,FA2,FA3,FA4  
 FAILURE MODE: Loss of Output to GPC

LEAD ANALYST: W. A. Haufler SUBSYS LEAD: B. Robb

BREAKDOWN HIERARCHY:

- 1) DPS
- 2) Multiplexer-DeMultiplexers (MDM)
- 3) Flight critical Aft MDM (FA1..4)
- 4)
- 5)
- 6)
- 7)
- 8)
- 9)

FLIGHT PHASE	CRITICALITIES		
	HDW/FUNC	ABORT	HDW/FUNC
PRELAUNCH:	3/2R	RTLS:	3/1R
LIFTOFF:	3/1R	TAL:	3/1R
ONORBIT:	3/2R	AOA:	3/1R
DEORBIT:	3/1R	ATO:	3/1R
LANDING/SAFING:	3/1R		

REDUNDANCY SCREENS: A [ 1 ] B [ P ] C [ P ]

LOCATION: Av Bay 4,5,6,6  
 PART NUMBER: MC615-0004-6110,5110

CAUSES: Vibration, Corrosion, Contamination

EFFECTS/RATIONALE:

FCOS sets Commfault flag for that data. Application SW ignores that data. FCOS bypasses MDM after 2nd consecutive commfault, and displays fault msg on CRTs. Port moding may recover MDM, but not allowed during ascent until after 2nd MDM failure. If all redundancy fails, lose use of aft RCS, Body Flap, Ailerons, Rudder, Speedbrake, and ability to purge SSMEs and tanks.

REFERENCES:

INDEPENDENT ORBITER ASSESSMENT  
ORBITER SUBSYSTEM ANALYSIS WORKSHEET

DATE: 10/03/86 HIGHEST CRITICALITY HDW/FUNC  
SUBSYSTEM: DPS FLIGHT: 3/1R  
MDAC ID: 121 ABORT: 3/1R

ITEM: MDM FA1,FA2,FA3,FA4  
FAILURE MODE: Loss of Output to LRU

LEAD ANALYST: W. A. Haufler SUBSYS LEAD: B. Robb

BREAKDOWN HIERARCHY:

- 1) DPS
- 2) Multiplexer-DeMultiplexers (MDM)
- 3) Flight critical Aft MDM (FA1..4)
- 4)
- 5)
- 6)
- 7)
- 8)
- 9)

CRITICALITIES			
FLIGHT PHASE	HDW/FUNC	ABORT	HDW/FUNC
PRELAUNCH:	3/2R	RTLS:	3/1R
LIFTOFF:	3/1R	TAL:	3/1R
ONORBIT:	3/2R	AOA:	3/1R
DEORBIT:	3/1R	ATO:	3/1R
LANDING/SAFING:	3/1R		

REDUNDANCY SCREENS: A [ 1 ] B [ P ] C [ P ]

LOCATION: Av Bay 4,5,6,6  
PART NUMBER: MC615-0004-6110,5110

CAUSES: Vibration, Corrosion, Contamination

EFFECTS/RATIONALE:

FCOS does not directly detect this error via MDM Return Word processing. Fault tolerance depends on redundant strings to voting LRUs. Detection depends on separate, redundant feedback signals.

If all redundancy fails, lose use of aft RCS, Body Flap, Ailerons, Rudder, Speedbrake, and ability to purge SSMEs and tanks.

REFERENCES:

INDEPENDENT ORBITER ASSESSMENT  
ORBITER SUBSYSTEM ANALYSIS WORKSHEET

DATE: 10/03/86 HIGHEST CRITICALITY HDW/FUNC  
SUBSYSTEM: DPS FLIGHT: 3/1R  
MDAC ID: 122 ABORT: 3/1R

ITEM: MDM FA1,FA2,FA3,FA4  
FAILURE MODE: Erroneous Output to GPC

LEAD ANALYST: W. A. Haufler SUBSYS LEAD: B. Robb

BREAKDOWN HIERARCHY:

- 1) DPS
- 2) Multiplexer-DeMultiplexers (MDM)
- 3) Flight critical Aft MDM (FA1..4)
- 4)
- 5)
- 6)
- 7)
- 8)
- 9)

FLIGHT PHASE	HDW/FUNC	CRITICALITIES	ABORT	HDW/FUNC
PRELAUNCH:	3/2R		RTLS:	3/1R
LIFTOFF:	3/1R		TAL:	3/1R
ONORBIT:	3/2R		AOA:	3/1R
DEORBIT:	3/1R		ATO:	3/1R
LANDING/SAFING:	3/1R			

REDUNDANCY SCREENS: A [ 1 ] B [ P ] C [ P ]

LOCATION: Av Bay 4,5,6,6  
PART NUMBER: MC615-0004-6110,5110

CAUSES: Vibration, Corrosion, Contamination

EFFECTS/RATIONALE:

FCOS sets Commfault flag for that data. Application SW ignores that data. FCOS bypasses MDM after 2nd consecutive commfault, and displays fault msg on CRTs. Port moding may recover MDM, but not allowed during ascent until after 2nd MDM failure. If all redundancy fails, lose use of aft RCS, Body Flap, Ailerons, Rudder, Speedbrake, and ability to purge SSMEs and tanks.

REFERENCES:

**INDEPENDENT ORBITER ASSESSMENT  
ORBITER SUBSYSTEM ANALYSIS WORKSHEET**

<b>DATE:</b>	10/03/86	<b>HIGHEST CRITICALITY</b>	<b>HDW/FUNC</b>
<b>SUBSYSTEM:</b>	DPS	<b>FLIGHT:</b>	3/1R
<b>MDAC ID:</b>	123	<b>ABORT:</b>	3/1R

**ITEM:** MDM FA1, FA2, FA3, FA4  
**FAILURE MODE:** Erroneous Output to LRU

**LEAD ANALYST:** W. A. Haufler      **SUBSYS LEAD:** B. Robb

**BREAKDOWN HIERARCHY:**

- 1) DPS
- 2) Multiplexer-DeMultiplexers (MDM)
- 3) Flight critical Aft MDM (FA1..4)
- 4)
- 5)
- 6)
- 7)
- 8)
- 9)

<b>CRITICALITIES</b>			
<b>FLIGHT PHASE</b>	<b>HDW/FUNC</b>	<b>ABORT</b>	<b>HDW/FUNC</b>
PRELAUNCH:	3/2R	RTLS:	3/1R
LIFTOFF:	3/1R	TAL:	3/1R
ONORBIT:	3/2R	AOA:	3/1R
DEORBIT:	3/1R	ATO:	3/1R
LANDING/SAFING:	3/1R		

**REDUNDANCY SCREENS:**    A [ 1 ]            B [ P ]            C [ P ]

**LOCATION:** Av Bay 4,5,6,6  
**PART NUMBER:** MC615-0004-6110,5110

**CAUSES:** Vibration, Corrosion, Contamination

**EFFECTS/RATIONALE:**

FCOS does not directly detect this error via MDM Return Word processing. Fault tolerance depends on redundant strings to voting LRUs. Detection depends on separate, redundant feedback signals.

If all redundancy fails, lose use of aft RCS, Body Flap, Ailerons, Rudder, Speedbrake, and ability to purge SSMEs and tanks.

**REFERENCES:**

INDEPENDENT ORBITER ASSESSMENT  
ORBITER SUBSYSTEM ANALYSIS WORKSHEET

DATE:	10/03/86	HIGHEST CRITICALITY	HDW/FUNC
SUBSYSTEM:	DPS	FLIGHT:	3/1R
MDAC ID:	124	ABORT:	3/1R

ITEM: MDM FA1, FA2, FA3, FA4  
FAILURE MODE: Premature Operation to GPC

LEAD ANALYST: W. A. Haufler                      SUBSYS LEAD: B. Robb

BREAKDOWN HIERARCHY:

- 1) DPS
- 2) Multiplexer-DeMultiplexers (MDM)
- 3) Flight critical Aft MDM (FA1..4)
- 4)
- 5)
- 6)
- 7)
- 8)
- 9)

FLIGHT PHASE	CRITICALITIES		HDW/FUNC
	HDW/FUNC	ABORT	
PRELAUNCH:	3/2R	RTLS:	3/1R
LIFTOFF:	3/1R	TAL:	3/1R
ONORBIT:	3/2R	AOA:	3/1R
DEORBIT:	3/1R	ATO:	3/1R
LANDING/SAFING:	3/1R		

REDUNDANCY SCREENS:    A [ 1 ]                      B [ P ]                      C [ P ]

LOCATION:                Av Bay 4,5,6,6  
PART NUMBER:        MC615-0004-6110,5110

CAUSES:    Vibration, Corrosion, Contamination

EFFECTS/RATIONALE:

This failure on either port can interfere with FCOS returning data from other BTU(s) and cause good BTU(s) to be bypassed. Port moding will not fix a blabbing MDM. Power cycling may reset electronics, but cannot be performed during ascent (power switches cannot be reached), and will not always stop premature operations. If all redundancy fails, lose use of aft RCS, Body Flap, Ailerons, Rudder, Speedbrake, and ability to purge SSMEs and tanks.

REFERENCES:

INDEPENDENT ORBITER ASSESSMENT  
ORBITER SUBSYSTEM ANALYSIS WORKSHEET

DATE: 10/03/86 HIGHEST CRITICALITY HDW/FUNC  
SUBSYSTEM: DPS FLIGHT: 3/1R  
MDAC ID: 125 ABORT: 3/1R

ITEM: MDM FA1,FA2,FA3,FA4  
FAILURE MODE: Premature Operation to LRU

LEAD ANALYST: W. A. Haufler SUBSYS LEAD: B. Robb

BREAKDOWN HIERARCHY:

- 1) DPS
- 2) Multiplexer-DeMultiplexers (MDM)
- 3) Flight critical Aft MDM (FA1..4)
- 4)
- 5)
- 6)
- 7)
- 8)
- 9)

CRITICALITIES			
FLIGHT PHASE	HDW/FUNC	ABORT	HDW/FUNC
PRELAUNCH:	3/2R	RTLS:	3/1R
LIFTOFF:	3/1R	TAL:	3/1R
ONORBIT:	3/2R	AOA:	3/1R
DEORBIT:	3/1R	ATO:	3/1R
LANDING/SAFING:	3/1R		

REDUNDANCY SCREENS: A [ 1 ] B [ P ] C [ P ]

LOCATION: Av Bay 4,5,6,6  
PART NUMBER: MC615-0004-6110,5110

CAUSES: Vibration, Corrosion, Contamination

EFFECTS/RATIONALE:

FCOS does not directly detect this error via MDM Return Word processing. Fault tolerance depends on redundant strings to voting LRUs. Detection depends on separate, redundant feedback signals.

If all redundancy fails, lose use of aft RCS, Body Flap, Ailerons, Rudder, Speedbrake, and ability to purge SSMEs and tanks.

REFERENCES:

INDEPENDENT ORBITER ASSESSMENT  
ORBITER SUBSYSTEM ANALYSIS WORKSHEET

DATE: 10/03/86 HIGHEST CRITICALITY HDW/FUNC  
SUBSYSTEM: DPS FLIGHT: 3/1R  
MDAC ID: 126 ABORT: 3/1R

ITEM: MDM FA1,FA2,FA3,FA4  
FAILURE MODE: Selected All Channels Wrong

LEAD ANALYST: W. A. Haufler SUBSYS LEAD: B. Robb

BREAKDOWN HIERARCHY:

- 1) DPS
- 2) Multiplexer-DeMultiplexers (MDM)
- 3) Flight critical Aft MDM (FA1..4)
- 4)
- 5)
- 6)
- 7)
- 8)
- 9)

CRITICALITIES			
FLIGHT PHASE	HDW/FUNC	ABORT	HDW/FUNC
PRELAUNCH:	3/2R	RTLS:	3/1R
LIFTOFF:	3/1R	TAL:	3/1R
ONORBIT:	3/2R	AOA:	3/1R
DEORBIT:	3/1R	ATO:	3/1R
LANDING/SAFING:	3/1R		

REDUNDANCY SCREENS: A [ 1 ] B [ P ] C [ P ]

LOCATION: Av Bay 4,5,6,6  
PART NUMBER: MC615-0004-6110,5110

CAUSES: Vibration, Corrosion, Contamination

EFFECTS/RATIONALE:

The GPC's FCOS and the LRUs would reject all data from that MDM except any data that happened to be in the same format as the expected data. Redundancy Mgt. soon detects and bypasses that MDM, and the effects of wrong data input or output is minimized. If all redundancy fails, lose use of aft RCS, Body Flap, Ailerons, Rudder, Speedbrake, and ability to purge SSMEs and tanks.

REFERENCES:

INDEPENDENT ORBITER ASSESSMENT  
ORBITER SUBSYSTEM ANALYSIS WORKSHEET

DATE: 10/03/86 HIGHEST CRITICALITY HDW/FUNC  
SUBSYSTEM: DPS FLIGHT: 3/1R  
MDAC ID: 127 ABORT: 3/1R

ITEM: MDM FA1,FA2,FA3,FA4  
FAILURE MODE: Stuck on a Constant Output to LRU

LEAD ANALYST: W. A. Haufler SUBSYS LEAD: B. Robb

BREAKDOWN HIERARCHY:

- 1) DPS
- 2) Multiplexer-DeMultiplexers (MDM)
- 3) Flight critical Aft MDM (FA1..4)
- 4)
- 5)
- 6)
- 7)
- 8)
- 9)

CRITICALITIES

FLIGHT PHASE	HDW/FUNC	ABORT	HDW/FUNC
PRELAUNCH:	3/2R	RTLS:	3/1R
LIFTOFF:	3/1R	TAL:	3/1R
ONORBIT:	3/2R	AOA:	3/1R
DEORBIT:	3/1R	ATO:	3/1R
LANDING/SAFING:	3/1R		

REDUNDANCY SCREENS: A [ 1 ] B [ P ] C [ P ]

LOCATION: Av Bay 4,5,6,6  
PART NUMBER: MC615-0004-6110,5110

CAUSES: Vibration, Corrosion, Contamination

EFFECTS/RATIONALE:

FCOS does not directly detect this error via MDM Return Word processing. Fault tolerance depends on redundant strings to voting LRUs. Detection depends on separate, redundant feedback signals.

If all redundancy fails, lose use of aft RCS, Body Flap, Ailerons, Rudder, Speedbrake, and ability to purge SSMEs and tanks.

REFERENCES:



INDEPENDENT ORBITER ASSESSMENT  
ORBITER SUBSYSTEM ANALYSIS WORKSHEET

DATE: 10/03/86 HIGHEST CRITICALITY HDW/FUNC  
SUBSYSTEM: DPS FLIGHT: 3/1R  
MDAC ID: 128 ABORT: 3/1R

ITEM: MDM FA1,FA2,FA3,FA4  
FAILURE MODE: Falsely Stuck on Busy Mode

LEAD ANALYST: W. A. Haufler SUBSYS LEAD: B. Robb

BREAKDOWN HIERARCHY:

- 1) DPS
- 2) Multiplexer-DeMultiplexers (MDM)
- 3) Flight critical Aft MDM (FA1..4)
- 4)
- 5)
- 6)
- 7)
- 8)
- 9)

	CRITICALITIES		
FLIGHT PHASE	HDW/FUNC	ABORT	HDW/FUNC
PRELAUNCH:	3/2R	RTLS:	3/1R
LIFTOFF:	3/1R	TAL:	3/1R
ONORBIT:	3/2R	AOA:	3/1R
DEORBIT:	3/1R	ATO:	3/1R
LANDING/SAFING:	3/1R		

REDUNDANCY SCREENS: A [ 1 ] B [ P ] C [ P ]

LOCATION: Av Bay 4,5,6,6  
PART NUMBER: MC615-0004-6110,5110

CAUSES: Vibration, Corrosion, Contamination, SCU Busy Cross-strap stuck high

EFFECTS/RATIONALE:

FCOS sets Commfault flag for that data. Application SW ignores that data. FCOS bypasses MDM after 2nd consecutive commfault, and displays fault msg on CRTs. Port moding may recover MDM, but not allowed during ascent until after 2nd MDM failure. If all redundancy fails, lose use of aft RCS, Body Flap, Ailerons, Rudder, Speedbrake, and ability to purge SSMEs and tanks.

REFERENCES:

INDEPENDENT ORBITER ASSESSMENT  
ORBITER SUBSYSTEM ANALYSIS WORKSHEET

DATE: 10/03/86 HIGHEST CRITICALITY HDW/FUNC  
SUBSYSTEM: DPS FLIGHT: 3/1R  
MDAC ID: 140 ABORT: 3/3

ITEM: MDM PF1,PF2  
FAILURE MODE: Loss of Output to GPC

LEAD ANALYST: W. A. Haufler SUBSYS LEAD: B. Robb

BREAKDOWN HIERARCHY:

- 1) DPS
- 2) Multiplexer-DeMultiplexers (MDM)
- 3) Payload Forward MDM (PF1..2)
- 4)
- 5)
- 6)
- 7)
- 8)
- 9)

CRITICALITIES			
FLIGHT PHASE	HDW/FUNC	ABORT	HDW/FUNC
PRELAUNCH:	3/2R	RTLS:	3/3
LIFTOFF:	3/3	TAL:	3/3
ONORBIT:	3/1R	AOA:	3/3
DEORBIT:	3/3	ATO:	3/3
LANDING/SAFING:	3/3		

REDUNDANCY SCREENS: A [ 1 ] B [ P ] C [ P ]

LOCATION: Av Bay 1,2  
PART NUMBER: MC615-0004-6710,5710

CAUSES: Vibration, Corrosion, Contamination

EFFECTS/RATIONALE:

FCOS/BSS sets Commfault flag for that data. Application SW ignores that data. System software bypasses MDM after 2nd consecutive commfault, and displays fault msg on CRTs. Port moding may not recover MDM.  
If all redundancy fails, lose ability to release, open, close, and latch Payload Bay Doors, and ability to cradle and latch RMS arm without an EVA.

REFERENCES:

INDEPENDENT ORBITER ASSESSMENT  
ORBITER SUBSYSTEM ANALYSIS WORKSHEET

DATE: 10/03/86 HIGHEST CRITICALITY HDW/FUNC  
SUBSYSTEM: DPS FLIGHT: 3/1R  
MDAC ID: 141 ABORT: 3/3

ITEM: MDM PF1,PF2  
FAILURE MODE: Loss of Output to LRU

LEAD ANALYST: W. A. Haufler SUBSYS LEAD: B. Robb

BREAKDOWN HIERARCHY:

- 1) DPS
- 2) Multiplexer-DeMultiplexers (MDM)
- 3) Payload Forward MDM (PF1..2)
- 4)
- 5)
- 6)
- 7)
- 8)
- 9)

CRITICALITIES			
FLIGHT PHASE	HDW/FUNC	ABORT	HDW/FUNC
PRELAUNCH:	3/2R	RTLS:	3/3
LIFTOFF:	3/3	TAL:	3/3
ONORBIT:	3/1R	AOA:	3/3
DEORBIT:	3/3	ATO:	3/3
LANDING/SAFING:	3/3		

REDUNDANCY SCREENS: A [ 1 ] B [ P ] C [ P ]

LOCATION: Av Bay 1,2  
PART NUMBER: MC615-0004-6710,5710

CAUSES: Vibration, Corrosion, Contamination

EFFECTS/RATIONALE:

FCOS/BSS does not directly detect this error via MDM Return Word processing. Fault tolerance depends on redundant PF MDMs. Detection depends on separate, redundant feedback signals. If all redundancy fails, lose ability to release, open, close, and latch Payload Bay Doors, and ability to cradle and latch RMS arm without an EVA.

REFERENCES:

INDEPENDENT ORBITER ASSESSMENT  
ORBITER SUBSYSTEM ANALYSIS WORKSHEET

DATE: 10/03/86 HIGHEST CRITICALITY HDW/FUNC  
SUBSYSTEM: DPS FLIGHT: 3/1R  
MDAC ID: 142 ABORT: 3/3

ITEM: MDM PF1,PF2  
FAILURE MODE: Erroneous Output to GPC

LEAD ANALYST: W. A. Haufler SUBSYS LEAD: B. Robb

BREAKDOWN HIERARCHY:

- 1) DPS
- 2) Multiplexer-DeMultiplexers (MDM)
- 3) Payload Forward MDM (PF1..2)
- 4)
- 5)
- 6)
- 7)
- 8)
- 9)

CRITICALITIES			
FLIGHT PHASE	HDW/FUNC	ABORT	HDW/FUNC
PRELAUNCH:	3/2R	RTLS:	3/3
LIFTOFF:	3/3	TAL:	3/3
ONORBIT:	3/1R	AOA:	3/3
DEORBIT:	3/3	ATO:	3/3
LANDING/SAFING:	3/3		

REDUNDANCY SCREENS: A [ 1 ] B [ P ] C [ P ]

LOCATION: Av Bay 1,2  
PART NUMBER: MC615-0004-6710,5710

CAUSES: Vibration, Corrosion, Contamination

EFFECTS/RATIONALE:

FCOS/BSS sets Commfault flag for that data. Application SW ignores that data. System software bypasses MDM after 2nd consecutive commfault, and displays fault msg on CRTs. Port moding may not recover MDM.  
If all redundancy fails, lose ability to release, open, close, and latch Payload Bay Doors, and ability to cradle and latch RMS arm without an EVA.

REFERENCES:

**INDEPENDENT ORBITER ASSESSMENT  
ORBITER SUBSYSTEM ANALYSIS WORKSHEET**

DATE:	10/03/86	HIGHEST CRITICALITY	HDW/FUNC
SUBSYSTEM:	DPS	FLIGHT:	3/1R
MDAC ID:	143	ABORT:	3/3

ITEM: MDM PF1,PF2  
FAILURE MODE: Erroneous Output to LRU

LEAD ANALYST: W. A. Haufler                      SUBSYS LEAD: B. Robb

**BREAKDOWN HIERARCHY:**

- 1) DPS
- 2) Multiplexer-DeMultiplexers (MDM)
- 3) Payload Forward MDM (PF1..2)
- 4)
- 5)
- 6)
- 7)
- 8)
- 9)

	CRITICALITIES			
FLIGHT PHASE	HDW/FUNC	ABORT		HDW/FUNC
PRELAUNCH:	3/2R	RTLS:		3/3
LIFTOFF:	3/3	TAL:		3/3
ONORBIT:	3/1R	AOA:		3/3
DEORBIT:	3/3	ATO:		3/3
LANDING/SAFING:	3/3			

REDUNDANCY SCREENS:    A [ 1 ]                      B [ P ]                      C [ P ]

LOCATION:            Av Bay 1,2  
PART NUMBER:    MC615-0004-6710,5710

CAUSES:    Vibration, Corrosion, Contamination

**EFFECTS/RATIONALE:**

FCOS/BSS does not directly detect this error via MDM Return Word processing. Fault tolerance depends on redundant PF MDMs. Detection depends on separate, redundant feedback signals. If all redundancy fails, lose ability to release, open, close, and latch Payload Bay Doors, and ability to cradle and latch RMS arm without an EVA.

**REFERENCES:**

INDEPENDENT ORBITER ASSESSMENT  
ORBITER SUBSYSTEM ANALYSIS WORKSHEET

DATE: 10/03/86                      HIGHEST CRITICALITY      HDW/FUNC  
SUBSYSTEM: DPS                      FLIGHT: 3/1R  
MDAC ID: 144                      ABORT: 3/3

ITEM: MDM PF1,PF2  
FAILURE MODE: Premature Operation to GPC

LEAD ANALYST: W. A. Haufler              SUBSYS LEAD: B. Robb

BREAKDOWN HIERARCHY:

- 1) DPS
- 2) Multiplexer-DeMultiplexers (MDM)
- 3) Payload Forward MDM (PF1..2)
- 4)
- 5)
- 6)
- 7)
- 8)
- 9)

FLIGHT PHASE	CRITICALITIES		
	HDW/FUNC	ABORT	HDW/FUNC
PRELAUNCH:	3/2R	RTLS:	3/3
LIFTOFF:	3/3	TAL:	3/3
ONORBIT:	3/1R	AOA:	3/3
DEORBIT:	3/3	ATO:	3/3
LANDING/SAFING:	3/3		

REDUNDANCY SCREENS:    A [ 1 ]              B [ P ]              C [ P ]

LOCATION:              Av Bay 1,2  
PART NUMBER:      MC615-0004-6710,5710

CAUSES:      Vibration, Corrosion, Contamination

EFFECTS/RATIONALE:

This failure on either port can interfere with FCOS/BSS returning data from other PF MDM and cause good MDM to be bypassed. Port moding will not fix a blabbing MDM. Power cycling may reset electronics, but will not always stop premature operations. If all redundancy fails, lose ability to release, open, close, and latch Payload Bay Doors, and ability to cradle and latch RMS arm without an EVA.

REFERENCES:

INDEPENDENT ORBITER ASSESSMENT  
ORBITER SUBSYSTEM ANALYSIS WORKSHEET

DATE:	10/03/86	HIGHEST CRITICALITY	HDW/FUNC
SUBSYSTEM:	DPS	FLIGHT:	3/1R
MDAC ID:	145	ABORT:	3/3

ITEM: MDM PF1,PF2  
FAILURE MODE: Premature Operation to LRU

LEAD ANALYST: W. A. Haufler                      SUBSYS LEAD: B. Robb

BREAKDOWN HIERARCHY:

- 1) DPS
- 2) Multiplexer-DeMultiplexers (MDM)
- 3) Payload Forward MDM                      (PF1..2)
- 4)
- 5)
- 6)
- 7)
- 8)
- 9)

CRITICALITIES			
FLIGHT PHASE	HDW/FUNC	ABORT	HDW/FUNC
PRELAUNCH:	3/2R	RTLS:	3/3
LIFTOFF:	3/3	TAL:	3/3
ONORBIT:	3/1R	AOA:	3/3
DEORBIT:	3/3	ATO:	3/3
LANDING/SAFING:	3/3		

REDUNDANCY SCREENS:    A [ 1 ]                      B [ P ]                      C [ P ]

LOCATION:              Av Bay 1,2  
PART NUMBER:      MC615-0004-6710,5710

CAUSES:    Vibration, Corrosion, Contamination

EFFECTS/RATIONALE:

FCOS/BSS does not directly detect this error via MDM Return Word processing. Fault tolerance depends on redundant PF MDMs. Detection depends on separate, redundant feedback signals. If all redundancy fails, lose ability to release, open, close, and latch Payload Bay Doors, and ability to cradle and latch RMS arm without an EVA.

REFERENCES:

**INDEPENDENT ORBITER ASSESSMENT  
ORBITER SUBSYSTEM ANALYSIS WORKSHEET**

DATE:	10/03/86	HIGHEST CRITICALITY	HDW/FUNC
SUBSYSTEM:	DPS	FLIGHT:	3/1R
MDAC ID:	146	ABORT:	3/3

ITEM: MDM PF1,PF2  
FAILURE MODE: Selected All Channels Wrong

LEAD ANALYST: W. A. Haufler      SUBSYS LEAD: B. Robb

**BREAKDOWN HIERARCHY:**

- 1) DPS
- 2) Multiplexer-DeMultiplexers (MDM)
- 3) Payload Forward MDM (PF1..2)
- 4)
- 5)
- 6)
- 7)
- 8)
- 9)

CRITICALITIES			
FLIGHT PHASE	HDW/FUNC	ABORT	HDW/FUNC
PRELAUNCH:	3/2R	RTLS:	3/3
LIFTOFF:	3/3	TAL:	3/3
ONORBIT:	3/1R	AOA:	3/3
DEORBIT:	3/3	ATO:	3/3
LANDING/SAFING:	3/3		

REDUNDANCY SCREENS:    A [ 1 ]      B [ P ]      C [ P ]

LOCATION:      Av Bay 1,2  
PART NUMBER: MC615-0004-6710,5710

CAUSES:      Vibration, Corrosion, Contamination

**EFFECTS/RATIONALE:**

The GPC's FCOS and the LRUs would reject all data from that MDM except any data that happened to be in the same format as the expected data. Redundancy Mgt. soon detects and bypasses that MDM, and the effects of wrong data input or output is minimized. If all redundancy fails, lose ability to release, open, close, and latch Payload Bay Doors, and ability to cradle and latch RMS arm without an EVA.

**REFERENCES:**



INDEPENDENT ORBITER ASSESSMENT  
ORBITER SUBSYSTEM ANALYSIS WORKSHEET

DATE: 10/03/86 HIGHEST CRITICALITY HDW/FUNC  
SUBSYSTEM: DPS FLIGHT: 3/1R  
MDAC ID: 147 ABORT: 3/3

ITEM: MDM PF1,PF2  
FAILURE MODE: Stuck on a Constant Output to LRU

LEAD ANALYST: W. A. Haufler SUBSYS LEAD: B. Robb

BREAKDOWN HIERARCHY:

- 1) DPS
- 2) Multiplexer-DeMultiplexers (MDM)
- 3) Payload Forward MDM (PF1..2)
- 4)
- 5)
- 6)
- 7)
- 8)
- 9)

FLIGHT PHASE	CRITICALITIES		HDW/FUNC
	HDW/FUNC	ABORT	
PRELAUNCH:	3/2R	RTLS:	3/3
LIFTOFF:	3/3	TAL:	3/3
ONORBIT:	3/1R	AOA:	3/3
DEORBIT:	3/3	ATO:	3/3
LANDING/SAFING:	3/3		

REDUNDANCY SCREENS: A [ 1 ] B [ P ] C [ P ]

LOCATION: Av Bay 1,2  
PART NUMBER: MC615-0004-6710,5710

CAUSES: Vibration, Corrosion, Contamination

EFFECTS/RATIONALE:

FCOS/BSS does not directly detect this error via MDM Return Word processing. Fault tolerance depends on redundant PF MDMs. Detection depends on separate, redundant feedback signals. If all redundancy fails, lose ability to release, open, close, and latch Payload Bay Doors, and ability to cradle and latch RMS arm without an EVA.

REFERENCES:

INDEPENDENT ORBITER ASSESSMENT  
ORBITER SUBSYSTEM ANALYSIS WORKSHEET

DATE: 10/03/86 HIGHEST CRITICALITY HDW/FUNC  
SUBSYSTEM: DPS FLIGHT: 3/1R  
MDAC ID: 148 ABORT: 3/3

ITEM: MDM PF1,PF2  
FAILURE MODE: Falsely Stuck on Busy Mode

LEAD ANALYST: W. A. Haufler SUBSYS LEAD: B. Robb

BREAKDOWN HIERARCHY:

- 1) DPS
- 2) Multiplexer-DeMultiplexers (MDM)
- 3) Payload Forward MDM (PF1..2)
- 4)
- 5)
- 6)
- 7)
- 8)
- 9)

CRITICALITIES			
FLIGHT PHASE	HDW/FUNC	ABORT	HDW/FUNC
PRELAUNCH:	3/2R	RTLS:	3/3
LIFTOFF:	3/3	TAL:	3/3
ONORBIT:	3/1R	AOA:	3/3
DEORBIT:	3/3	ATO:	3/3
LANDING/SAFING:	3/3		

REDUNDANCY SCREENS: A [ 1 ] B [ P ] C [ P ]

LOCATION: Av Bay 1,2  
PART NUMBER: MC615-0004-6710,5710

CAUSES: Vibration, Corrosion, Contamination, SCU Busy Cross-strap stuck high

EFFECTS/RATIONALE:

FCOS/BSS sets Commfault flag for that data. Application SW ignores that data. System software bypasses MDM after 2nd consecutive commfault, and displays fault msg on CRTs. Port moding may not recover MDM.  
If all redundancy fails, lose ability to release, open, close, and latch Payload Bay Doors, and ability to cradle and latch RMS arm without an EVA.

REFERENCES:

INDEPENDENT ORBITER ASSESSMENT  
ORBITER SUBSYSTEM ANALYSIS WORKSHEET

DATE: 10/03/86 HIGHEST CRITICALITY HDW/FUNC  
SUBSYSTEM: DPS FLIGHT: 3/2R  
MDAC ID: 180 ABORT: /NA

ITEM: MDM LF1, LA1  
FAILURE MODE: Loss of Output to GPC

LEAD ANALYST: W. A. Haufler SUBSYS LEAD: B. Robb

BREAKDOWN HIERARCHY:

- 1) DPS
- 2) Multiplexer-DeMultiplexers (MDM)
- 3) PreLaunch Forward & Aft MDM (LF,LA)
- 4)
- 5)
- 6)
- 7)
- 8)
- 9)

FLIGHT PHASE	CRITICALITIES		HDW/FUNC
	HDW/FUNC	ABORT	
PRELAUNCH:	3/2R	RTLS:	/NA
LIFTOFF:	/NA	TAL:	/NA
ONORBIT:	/NA	AOA:	/NA
DEORBIT:	/NA	ATO:	/NA
LANDING/SAFING:	3/2R		

REDUNDANCY SCREENS: A [ 1 ] B [ NA ] C [ P ]

LOCATION: Av Bay 1,6  
PART NUMBER: MC615-0004-6610,5600

CAUSES: Vibration, Corrosion, Contamination

EFFECTS/RATIONALE:

FCOS sets Commfault flag for that data. Application SW ignores that data. FCOS bypasses MDM after 2nd consecutive commfault, and displays fault msg on CRTs. Port moding may recover MDM. If all redundancy fails, lose ability of GSE to monitor and control systems while attached.

REFERENCES:

INDEPENDENT ORBITER ASSESSMENT  
ORBITER SUBSYSTEM ANALYSIS WORKSHEET

DATE:	10/03/86	HIGHEST CRITICALITY	HDW/FUNC
SUBSYSTEM:	DPS	FLIGHT:	3/2R
MDAC ID:	181	ABORT:	/NA

ITEM: MDM LF1, LA1  
FAILURE MODE: Loss of Output to LRU

LEAD ANALYST: W. A. Haufler                      SUBSYS LEAD: B. Robb

BREAKDOWN HIERARCHY:

- 1) DPS
- 2) Multiplexer-DeMultiplexers (MDM)
- 3) preLaunch Forward & Aft MDM (LF, LA)
- 4)
- 5)
- 6)
- 7)
- 8)
- 9)

CRITICALITIES

FLIGHT PHASE	HDW/FUNC	ABORT	HDW/FUNC
PRELAUNCH:	3/2R	RTLS:	/NA
LIFTOFF:	/NA	TAL:	/NA
ONORBIT:	/NA	AOA:	/NA
DEORBIT:	/NA	ATO:	/NA
LANDING/SAFING:	3/2R		

REDUNDANCY SCREENS:    A [ 1 ]            B [ NA ]            C [ P ]

LOCATION:            Av Bay 1,6  
PART NUMBER:    MC615-0004-6610,5600

CAUSES:    Vibration, Corrosion, Contamination

EFFECTS/RATIONALE:

FCOS does not directly detect this error via MDM Return Word processing. Fault tolerance depends on redundant strings to voting LRUs. Detection depends on separate, redundant feedback signals.

If all redundancy fails, lose ability of GSE to monitor and control systems while attached.

REFERENCES:

INDEPENDENT ORBITER ASSESSMENT  
ORBITER SUBSYSTEM ANALYSIS WORKSHEET

DATE: 10/03/86 HIGHEST CRITICALITY HDW/FUNC  
SUBSYSTEM: DPS FLIGHT: 3/2R  
MDAC ID: 182 ABORT: /NA

ITEM: MDM LF1, LA1  
FAILURE MODE: Erroneous Output to GPC

LEAD ANALYST: W. A. Haufler SUBSYS LEAD: B. Robb

BREAKDOWN HIERARCHY:

- 1) DPS
- 2) Multiplexer-DeMultiplexers (MDM)
- 3) preLaunch Forward & Aft MDM (LF, LA)
- 4)
- 5)
- 6)
- 7)
- 8)
- 9)

CRITICALITIES

FLIGHT PHASE	HDW/FUNC	ABORT	HDW/FUNC
PRELAUNCH:	3/2R	RTL:	/NA
LIFTOFF:	/NA	TAL:	/NA
ONORBIT:	/NA	AOA:	/NA
DEORBIT:	/NA	ATO:	/NA
LANDING/SAFING:	3/2R		

REDUNDANCY SCREENS: A [ 1 ] B [ NA ] C [ P ]

LOCATION: Av Bay 1,6  
PART NUMBER: MC615-0004-6610,5600

CAUSES: Vibration, Corrosion, Contamination

EFFECTS/RATIONALE:

FCOS sets Commfault flag for that data. Application SW ignores that data. FCOS bypasses MDM after 2nd consecutive commfault, and displays fault msg on CRTs. Port moding may recover MDM, but not allowed during ascent until after 2nd MDM failure. If all redundancy fails, lose ability of GSE to monitor and control systems while attached.

REFERENCES:

INDEPENDENT ORBITER ASSESSMENT  
ORBITER SUBSYSTEM ANALYSIS WORKSHEET

DATE:	10/03/86	HIGHEST CRITICALITY	HDW/FUNC
SUBSYSTEM:	DPS	FLIGHT:	3/2R
MDAC ID:	183	ABORT:	/NA

ITEM: MDM LFl, LA1  
FAILURE MODE: Erroneous Output to LRU

LEAD ANALYST: W. A. Haufler                      SUBSYS LEAD: B. Robb

BREAKDOWN HIERARCHY:

- 1) DPS
- 2) Multiplexer-DeMultiplexers (MDM)
- 3) preLaunch Forward & Aft MDM (LF, LA)
- 4)
- 5)
- 6)
- 7)
- 8)
- 9)

FLIGHT PHASE	HDW/FUNC	CRITICALITIES	ABORT	HDW/FUNC
PRELAUNCH:	3/2R		RTLS:	/NA
LIFTOFF:	/NA		TAL:	/NA
ONORBIT:	/NA		AOA:	/NA
DEORBIT:	/NA		ATO:	/NA
LANDING/SAFING:	3/2R			

REDUNDANCY SCREENS:    A [ 1 ]                      B [ NA ]                      C [ P ]

LOCATION:                      Av Bay 1,6  
PART NUMBER:                MC615-0004-6610,5600

CAUSES:    Vibration, Corrosion, Contamination

EFFECTS/RATIONALE:

FCOS does not directly detect this error via MDM Return Word processing. Fault tolerance depends on redundant strings to voting LRUs. Detection depends on separate, redundant feedback signals.

If all redundancy fails, lose ability of GSE to monitor and control systems while attached.

REFERENCES:

INDEPENDENT ORBITER ASSESSMENT  
ORBITER SUBSYSTEM ANALYSIS WORKSHEET

DATE: 10/03/86 HIGHEST CRITICALITY HDW/FUNC  
SUBSYSTEM: DPS FLIGHT: 3/2R  
MDAC ID: 184 ABORT: /NA

ITEM: MDM LF1, LA1  
FAILURE MODE: Premature Operation to GPC

LEAD ANALYST: W. A. Haufler SUBSYS LEAD: B. Robb

BREAKDOWN HIERARCHY:

- 1) DPS
- 2) Multiplexer-DeMultiplexers (MDM)
- 3) preLaunch Forward & Aft MDM (LF, LA)
- 4)
- 5)
- 6)
- 7)
- 8)
- 9)

CRITICALITIES			
FLIGHT PHASE	HDW/FUNC	ABORT	HDW/FUNC
PRELAUNCH:	3/2R	RTLS:	/NA
LIFTOFF:	/NA	TAL:	/NA
ONORBIT:	/NA	AOA:	/NA
DEORBIT:	/NA	ATO:	/NA
LANDING/SAFING:	3/2R		

REDUNDANCY SCREENS: A [ 1 ] B [ NA ] C [ P ]

LOCATION: Av Bay 1,6  
PART NUMBER: MC615-0004-6610,5600

CAUSES: Vibration, Corrosion, Contamination

EFFECTS/RATIONALE:

This failure on either port can interfere with FCOS returning data from other BTU(s) and cause good BTU(s) to be bypassed. Port moding will not fix a blabbing MDM. Power cycling may reset electronics, but will not always stop premature operations. If all redundancy fails, lose ability of GSE to monitor and control systems while attached.

REFERENCES:

INDEPENDENT ORBITER ASSESSMENT  
ORBITER SUBSYSTEM ANALYSIS WORKSHEET

DATE: 10/03/86 HIGHEST CRITICALITY HDW/FUNC  
SUBSYSTEM: DPS FLIGHT: 3/2R  
MDAC ID: 185 ABORT: /NA

ITEM: MDM LF1,LA1  
FAILURE MODE: Premature Operation to LRU

LEAD ANALYST: W. A. Haufler SUBSYS LEAD: B. Robb

BREAKDOWN HIERARCHY:

- 1) DPS
- 2) Multiplexer-DeMultiplexers (MDM)
- 3) preLaunch Forward & Aft MDM (LF,LA)
- 4)
- 5)
- 6)
- 7)
- 8)
- 9)

FLIGHT PHASE	HDW/FUNC	ABORT	HDW/FUNC
PRELAUNCH:	3/2R	RTLS:	/NA
LIFTOFF:	/NA	TAL:	/NA
ONORBIT:	/NA	AOA:	/NA
DEORBIT:	/NA	ATO:	/NA
LANDING/SAFING:	3/2R		

REDUNDANCY SCREENS: A [ 1 ] B [ NA ] C [ P ]

LOCATION: Av Bay 1,6  
PART NUMBER: MC615-0004-6610,5600

CAUSES: Vibration, Corrosion, Contamination

EFFECTS/RATIONALE:

FCOS does not directly detect this error via MDM Return Word processing. Fault tolerance depends on redundant strings to voting LRUs. Detection depends on separate, redundant feedback signals.

If all redundancy fails, lose ability of GSE to monitor and control systems while attached.

REFERENCES:



INDEPENDENT ORBITER ASSESSMENT  
ORBITER SUBSYSTEM ANALYSIS WORKSHEET

DATE: 10/03/86 HIGHEST CRITICALITY HDW/FUNC  
SUBSYSTEM: DPS FLIGHT: 3/2R  
MDAC ID: 186 ABORT: /NA

ITEM: MDM LF1, LA1  
FAILURE MODE: Selected All Channels Wrong

LEAD ANALYST: W. A. Haufler SUBSYS LEAD: B. Robb

BREAKDOWN HIERARCHY:

- 1) DPS
- 2) Multiplexer-DeMultiplexers (MDM)
- 3) preLaunch Forward & Aft MDM (LF, LA)
- 4)
- 5)
- 6)
- 7)
- 8)
- 9)

CRITICALITIES			
FLIGHT PHASE	HDW/FUNC	ABORT	HDW/FUNC
PRELAUNCH:	3/2R	RTLS:	/NA
LIFTOFF:	/NA	TAL:	/NA
ONORBIT:	/NA	AOA:	/NA
DEORBIT:	/NA	ATO:	/NA
LANDING/SAFING:	3/2R		

REDUNDANCY SCREENS: A [ 1 ] B [ NA ] C [ P ]

LOCATION: Av Bay 1,6  
PART NUMBER: MC615-0004-6610,5600

CAUSES: Vibration, Corrosion, Contamination

EFFECTS/RATIONALE:

The GPC's FCOS and the LRUs would reject all data from that MDM except any data that happened to be in the same format as the expected data. Redundancy Mgt. soon detects and bypasses that MDM, and the effects of wrong data input or output is minimized. If all redundancy fails, lose ability of GSE to monitor and control systems while attached.

REFERENCES:



INDEPENDENT ORBITER ASSESSMENT  
ORBITER SUBSYSTEM ANALYSIS WORKSHEET

DATE:	10/03/86	HIGHEST CRITICALITY	HDW/FUNC
SUBSYSTEM:	DPS	FLIGHT:	3/2R
MDAC ID:	188	ABORT:	/NA

ITEM: MDM LF1, LA1  
FAILURE MODE: Falsely Stuck on Busy Mode

LEAD ANALYST: W. A. Haufler                      SUBSYS LEAD: B. Robb

BREAKDOWN HIERARCHY:

- 1) DPS
- 2) Multiplexer-DeMultiplexers (MDM)
- 3) preLaunch Forward & Aft MDM (LF, LA)
- 4)
- 5)
- 6)
- 7)
- 8)
- 9)

FLIGHT PHASE	HDW/FUNC	CRITICALITIES	ABORT	HDW/FUNC
PRELAUNCH:	3/2R		RTLS:	/NA
LIFTOFF:	/NA		TAL:	/NA
ONORBIT:	/NA		AOA:	/NA
DEORBIT:	/NA		ATO:	/NA
LANDING/SAFING:	3/2R			

REDUNDANCY SCREENS:    A [ 1 ]                      B [ NA ]                      C [ P ]

LOCATION:                      Av Bay 1,6  
PART NUMBER:                MC615-0004-6610,5600

CAUSES:    Vibration, Corrosion, Contamination, SCU Busy Cross-strap stuck high

EFFECTS/RATIONALE:

FCOS sets Commfault flag for that data. Application SW ignores that data. FCOS bypasses MDM after 2nd consecutive commfault, and displays fault msg on CRTs. Port moding may recover MDM. If all redundancy fails, lose ability of GSE to monitor and control systems while attached.

REFERENCES:

INDEPENDENT ORBITER ASSESSMENT  
ORBITER SUBSYSTEM ANALYSIS WORKSHEET

DATE: 10/22/86 HIGHEST CRITICALITY HDW/FUNC  
SUBSYSTEM: DPS FLIGHT: 3/1R  
MDAC ID: 190 ABORT: 3/1R

ITEM: RESISTOR, CURRENT LIMITING  
FAILURE MODE: OPEN

LEAD ANALYST: W. A. HAUFLER SUBSYS LEAD: B. ROBB

BREAKDOWN HIERARCHY:

- 1) DPS
- 2) MULTIPLEXER-DEMULPLEXERS (MDM)
- 3) POWER DISTRIBUTION
- 4) RESISTOR, CURRENT LIMITING
- 5)
- 6)
- 7)
- 8)
- 9)

	CRITICALITIES		
FLIGHT PHASE	HDW/FUNC	ABORT	HDW/FUNC
PRELAUNCH:	3/2R	RTLS:	3/1R
LIFTOFF:	3/1R	TAL:	3/1R
ONORBIT:	3/2R	AOA:	3/1R
DEORBIT:	3/1R	ATO:	3/1R
LANDING/SAFING:	3/1R		

REDUNDANCY SCREENS: A [ 1 ] B [ F ] C [ P ]

LOCATION:  
PART NUMBER: RWR80S1211FR

CAUSES: THERMAL STRESS, VIBRATION, SHOCK, FRACTURE

EFFECTS/RATIONALE:

NO EFFECT ON ONE FAILURE SINCE MDM ARE NOT INTERRUPTED WITH LOSS OF ONE-OF-TWO POWER CIRCUITS. NO EFFECT ON FAILURES OF BOTH RESISTORS (NO LOSS OF VEHICLE) SINCE MDM ARE ALSO REDUNDANT.

REFERENCES:

INDEPENDENT ORBITER ASSESSMENT  
ORBITER SUBSYSTEM ANALYSIS WORKSHEET

DATE: 10/22/86 HIGHEST CRITICALITY HDW/FUNC  
SUBSYSTEM: DPS FLIGHT: 3/1R  
MDAC ID: 191 ABORT: 3/1R

ITEM: CONTROLLER, REMOTE POWER  
FAILURE MODE: LOSS OF OUTPUT, FAILS TO CONDUCT, OPEN OR SHORT TO GROUND

LEAD ANALYST: W. A. HAUFLEER SUBSYS LEAD: B. ROBB

BREAKDOWN HIERARCHY:

- 1) DPS
- 2) MULTIPLEXER-DEMUTIPLEXERS (MDM)
- 3) POWER DISTRIBUTION
- 4) CONTROLLER, REMOTE POWER
- 5)
- 6)
- 7)
- 8)
- 9)

CRITICALITIES			
FLIGHT PHASE	HDW/FUNC	ABORT	HDW/FUNC
PRELAUNCH:	3/2R	RTLS:	3/1R
LIFTOFF:	3/1R	TAL:	3/1R
ONORBIT:	3/2R	AOA:	3/1R
DEORBIT:	3/1R	ATO:	3/1R
LANDING/SAFING:	3/1R		

REDUNDANCY SCREENS: A [ 1 ] B [ F ] C [ P ]

LOCATION:  
PART NUMBER: MC450-0017-2050, 2075

CAUSES: PIECE PART STRUCTURE FAILURE, VIBRATION, THERMAL STRESS

EFFECTS/RATIONALE:  
NO EFFECT ON ONE FAILURE SINCE MDM ARE NOT INTERRUPTED WITH LOSS OF ONE-OF-TWO POWER CIRCUITS. NO EFFECT ON FAILURE (NO LOSS OF VEHICLE) OF BOTH RESISTORS SINCE MDM ARE ALSO REDUNDANT.

REFERENCES:

INDEPENDENT ORBITER ASSESSMENT  
ORBITER SUBSYSTEM ANALYSIS WORKSHEET

DATE: 10/22/86 HIGHEST CRITICALITY HDW/FUNC  
SUBSYSTEM: DPS FLIGHT: 3/3  
MDAC ID: 192 ABORT: 3/3

ITEM: CONTROLLER, REMOTE POWER  
FAILURE MODE: INADVERTENT OPERATION: CONDUCTS PREMATURELY

LEAD ANALYST: W. A. HAUFLER SUBSYS LEAD: B. ROBB

BREAKDOWN HIERARCHY:

- 1) DPS
- 2) MULTIPLEXER-DEMULPLEXERS (MDM)
- 3) POWER DISTRIBUTION
- 4) CONTROLLER, REMOTE POWER
- 5)
- 6)
- 7)
- 8)
- 9)

FLIGHT PHASE	CRITICALITIES		
	HDW/FUNC	ABORT	HDW/FUNC
PRELAUNCH:	3/3	RTLS:	3/3
LIFTOFF:	3/3	TAL:	3/3
ONORBIT:	3/3	AOA:	3/3
DEORBIT:	3/3	ATO:	3/3
LANDING/SAFING:	3/3		

REDUNDANCY SCREENS: A [NA ] B [NA ] C [NA ]

LOCATION:  
PART NUMBER:

CAUSES: CONTAMINATION, SHOCK, PIECE PART FAILURE

EFFECTS/RATIONALE:

NO EFFECT ON ANY MDMs THAT ARE OPERATIONAL THROUGHOUT THE ENTIRE MISSION (FF1,3 AND FA1,2). POWER WILL BE APPLIED TO ANY ONE OF THE FOLLOWING MDMs: FF2,4 AND FA3,4 IF ITS DEDICATED SWITCH FAILS AND IF THE APPROPRIATE POWER BUSES ARE "ON".

REFERENCES:

INDEPENDENT ORBITER ASSESSMENT  
ORBITER SUBSYSTEM ANALYSIS WORKSHEET

DATE: 10/22/86 HIGHEST CRITICALITY HDW/FUNC  
SUBSYSTEM: DPS FLIGHT: 3/1R  
MDAC ID: 193 ABORT: 3/1R

ITEM: SWITCH, MDM POWER  
FAILURE MODE: FAILS OPEN

LEAD ANALYST: W. A. HAUFLEER SUBSYS LEAD: B. ROBB

BREAKDOWN HIERARCHY:

- 1) DPS
- 2) MULTIPLEXER-DEMULPLEXERS (MDM)
- 3) FA, FF2, FF4, AND PF MDMs
- 4) POWER DISTRIBUTION
- 5) SWITCH, MDM POWER
- 6)
- 7)
- 8)
- 9)

FLIGHT PHASE	CRITICALITIES		HDW/FUNC
	HDW/FUNC	ABORT	
PRELAUNCH:	3/2R	RTLS:	3/1R.
LIFTOFF:	3/1R	TAL:	3/1R
ONORBIT:	3/2R	AOA:	3/1R
DEORBIT:	3/1R	ATO:	3/1R
LANDING/SAFING:	3/1R		

REDUNDANCY SCREENS: A [ 1 ] B [ F ] C [ P ]

LOCATION:  
PART NUMBER: ME452-0102-7201

CAUSES: PIECE-PART STRUCTURAL FAILURE, CONTAMINATION, MECHANICAL SHOCK, VIBRATION

EFFECTS/RATIONALE:

NO EFFECT ON ONE FAILURE SINCE MDM ARE NOT INTERRUPTED WITH LOSS OF ONE-OF-TWO POWER CIRCUITS. NO EFFECT ON FAILURES OF BOTH RESISTORS (NO LOSS OF VEHICLE) SINCE MDMs ARE ALSO REDUNDANT.

REFERENCES:

INDEPENDENT ORBITER ASSESSMENT  
ORBITER SUBSYSTEM ANALYSIS WORKSHEET

DATE: 10/22/86	HIGHEST CRITICALITY	HDW/FUNC
SUBSYSTEM: DPS	FLIGHT:	3/3
MDAC ID: 194	ABORT:	3/3

ITEM: SWITCH, MDM POWER  
FAILURE MODE: PREMATURE OPERATION: CLOSING INADVERTENTLY

LEAD ANALYST: W. A. HAUFLEER                      SUBSYS LEAD: B. ROBB

BREAKDOWN HIERARCHY:

- 1) DPS
- 2) MULTIPLEXER-DEMULPLEXERS (MDM)
- 3) FA, FF2, FF4, AND PF MDMs
- 4) POWER DISTRIBUTION
- 5) SWITCH, MDM POWER
- 6)
- 7)
- 8)
- 9)

FLIGHT PHASE	CRITICALITIES		HDW/FUNC
	HDW/FUNC	ABORT	
PRELAUNCH:	3/3	RTLS:	3/3
LIFTOFF:	3/3	TAL:	3/3
ONORBIT:	3/3	AOA:	3/3
DEORBIT:	3/3	ATO:	3/3
LANDING/SAFING:	3/3		

REDUNDANCY SCREENS:    A [ NA ]                      B [ NA ]                      C [ NA ]

LOCATION:  
PART NUMBER: ME452-0102-7201

CAUSES: PIECE-PART STRUCTURAL FAILURE, SHOCK, VIBRATION, THERMAL STRESS

EFFECTS/RATIONALE:  
NO EFFECT ON MDMs THAT ARE OPERATIONAL THROUGHOUT THE ENTIRE MISSION. THIS SWITCH FAILURE WILL INADVERTENTLY POWER UP MDMs THAT MIGHT BE OFF; I.E. FA3, FA4, FF2, AND FF4. NO LOSS OF VEHICLE.

REFERENCES:



INDEPENDENT ORBITER ASSESSMENT  
ORBITER SUBSYSTEM ANALYSIS WORKSHEET

DATE: 10/22/86 HIGHEST CRITICALITY HDW/FUNC  
SUBSYSTEM: DPS FLIGHT: 3/1R  
MDAC ID: 195 ABORT: 3/1R

ITEM: SWITCH, MDM POWER  
FAILURE MODE: FAILS OPEN

LEAD ANALYST: W. A. HAUFLER SUBSYS LEAD: B. ROBB

BREAKDOWN HIERARCHY:

- 1) DPS
- 2) MULTIPLEXER-DEMULPLEXERS (MDM)
- 3) FF1, AND FF3 MDMs
- 4) POWER DISTRIBUTION
- 5) SWITCH, MDM POWER
- 6)
- 7)
- 8)
- 9)

CRITICALITIES			
FLIGHT PHASE	HDW/FUNC	ABORT	HDW/FUNC
PRELAUNCH:	3/2R	RTLS:	3/1R
LIFTOFF:	3/1R	TAL:	3/1R
ONORBIT:	3/2R	AOA:	3/1R
DEORBIT:	3/1R	ATO:	3/1R
LANDING/SAFING:	3/1R		

REDUNDANCY SCREENS: A [ 1 ] B [ F ] C [ P ]

LOCATION:  
PART NUMBER: ME452-0102-7210

CAUSES: STRUCTURAL FAILURE, CONTAMINATION, MECHANICAL SHOCK,  
VIBRATION

EFFECTS/RATIONALE:

NO EFFECT ON ONE FAILURE SINCE MDM ARE NOT INTERRUPTED WITH LOSS OF ONE-OF-TWO POWER CIRCUITS. TWO FAILURE (LOSS OF BOTH POWER CIRCUITS AND THUS BOTH FF1 AND FF3) WOULD CAUSE LOSS OF ONE NSP INTERFACE.

WORKAROUND EXISTS TO UPDATE STATE VECTOR WITH LOSS OF BOTH FF1 AND FF3.

REFERENCES:

INDEPENDENT ORBITER ASSESSMENT  
ORBITER SUBSYSTEM ANALYSIS WORKSHEET

DATE: 10/03/86 HIGHEST CRITICALITY HDW/FUNC  
SUBSYSTEM: DPS FLIGHT: 3/1R  
MDAC ID: 201 ABORT: 3/1R

ITEM: Input/Output Processor (IOP)  
FAILURE MODE: Loss of output

LEAD ANALYST: T. B. Cribbs SUBSYS LEAD: B. Robb

BREAKDOWN HIERARCHY:

- 1) DPS
- 2) General Purpose Computer (GPC)
- 3) Input/Output Processor (IOP)
- 4)
- 5)
- 6)
- 7)
- 8)
- 9)

CRITICALITIES			
FLIGHT PHASE	HDW/FUNC	ABORT	HDW/FUNC
PRELAUNCH:	3/2R	RTLS:	3/1R
LIFTOFF:	3/1R	TAL:	3/1R
ONORBIT:	3/2R	AOA:	3/1R
DEORBIT:	3/1R	ATO:	3/1R
LANDING/SAFING:	3/1R		

REDUNDANCY SCREENS: A [ 1 ] B [ P ] C [ P ]

LOCATION: Av Bays  
PART NUMBER:

CAUSES: MIA Fails to output to data bus due to piece/part failure from contamination or mechanical, thermal, or electrical overstress, or power failure

EFFECTS/RATIONALE:

Loss of a bus-commanding MIA results in loss of a GPC's ability to communicate over that bus, attached bus terminal units (BTU's), and all inputs and outputs connected to those BTU's. In dynamic flight phases, where a single BTU controls an actuator, the crew would have to manually intervene on a single failure, and switching transients could arise. Loss of all redundancy would cause loss of vehicle control.

REFERENCES: JSC 18820, JSC 11174, JSC 12770

INDEPENDENT ORBITER ASSESSMENT  
ORBITER SUBSYSTEM ANALYSIS WORKSHEET

DATE: 10/03/86 HIGHEST CRITICALITY HDW/FUNC  
SUBSYSTEM: DPS FLIGHT: 3/1R  
MDAC ID: 202 ABORT: 3/1R

ITEM: Input/Output Processor (IOP)  
FAILURE MODE: Erratic/Erroneous Output

LEAD ANALYST: T. B. Cribbs SUBSYS LEAD: B. Robb

BREAKDOWN HIERARCHY:

- 1) DPS
- 2) General Purpose Computer (GPC)
- 3) Input/Output Processor (IOP)
- 4)
- 5)
- 6)
- 7)
- 8)
- 9)

CRITICALITIES			
FLIGHT PHASE	HDW/FUNC	ABORT	HDW/FUNC
PRELAUNCH:	3/2R	RTLS:	3/1R
LIFTOFF:	3/1R	TAL:	3/1R
ONORBIT:	3/2R	AOA:	3/1R
DEORBIT:	3/1R	ATO:	3/1R
LANDING/SAFING:	3/1R		

REDUNDANCY SCREENS: A [ 1 ] B [ P ] C [ P ]

LOCATION: Av Bays  
PART NUMBER:

CAUSES: Component failure due to contamination or mechanical, thermal, or electrical overstress in MIA, ALU, MUX, Local Store, or Memory

EFFECTS/RATIONALE:

Critical GPC outputs are validated by sumword comparison; however, errors are downlinked and logged, but not corrected. MDM/Actuator hardware cancels the effects of an erroneous output from a single channel by "Force fighting", but multiple failures during critical flight phases would likely result in loss of vehicel/life.

REFERENCES: JSC 18820, JSC 11174, JSC 12770

INDEPENDENT ORBITER ASSESSMENT  
ORBITER SUBSYSTEM ANALYSIS WORKSHEET

DATE: 10/22/86 HIGHEST CRITICALITY HDW/FUNC  
SUBSYSTEM: DPS FLIGHT: 3/1R  
MDAC ID: 203 ABORT: 3/1R

ITEM: Input/Output Processor (IOP)  
FAILURE MODE: Premature Operation

LEAD ANALYST: T. B. Cribbs SUBSYS LEAD: B. Robb

BREAKDOWN HIERARCHY:

- 1) DPS
- 2) General Purpose Computer (GPC)
- 3) Input/Output Processor (IOP)
- 4)
- 5)
- 6)
- 7)
- 8)
- 9)

CRITICALITIES			
FLIGHT PHASE	HDW/FUNC	ABORT	HDW/FUNC
PRELAUNCH:	3/3	RTLS:	2/1R
LIFTOFF:	2/1R	TAL:	2/1R
ONORBIT:	3/2R	AOA:	3/1R
DEORBIT:	2/1R	ATO:	3/1R
LANDING/SAFING:	2/1R		

REDUNDANCY SCREENS: A [ 1 ] B [ P ] C [ P ]

LOCATION: Av Bays  
PART NUMBER:

CAUSES: Control monitor, channel control, MSC, or microcode store failure results in invalid execution of program. Caused by piece/part failure.

EFFECTS/RATIONALE:

Premature issuance of critical outputs is detected by other GPC's in the Redundant Set. GPC fails to sync and strings are bypassed by other GPC's. Faulty commands are still passed to the actuator by failed GPC. Premature commands to actuators during dynamic flight phases would likely result in loss of vehicle/life, if actuator redundancy was lost or if simultaneous loss of two output channels.

REFERENCES: JSC 18820, JSC 11174, JSC 12770

INDEPENDENT ORBITER ASSESSMENT  
ORBITER SUBSYSTEM ANALYSIS WORKSHEET

DATE: 10/03/86 HIGHEST CRITICALITY HDW/FUNC  
SUBSYSTEM: DPS FLIGHT: 3/1R  
MDAC ID: 204 ABORT: 3/1R

ITEM: Input/Output Processor (IOP)  
FAILURE MODE: Erroneous Input

LEAD ANALYST: T. B. Cribbs SUBSYS LEAD: B. Robb

BREAKDOWN HIERARCHY:

- 1) DPS
- 2) General Purpose Computer (GPC)
- 3) Input/Output Processor (IOP)
- 4)
- 5)
- 6)
- 7)
- 8)
- 9)

CRITICALITIES			
FLIGHT PHASE	HDW/FUNC	ABORT	HDW/FUNC
PRELAUNCH:	3/2R	RTLS:	3/1R
LIFTOFF:	3/1R	TAL:	3/1R
ONORBIT:	3/2R	AOA:	3/1R
DEORBIT:	3/1R	ATO:	3/1R
LANDING/SAFING:	3/3		

REDUNDANCY SCREENS: A [ 1 ] B [ P ] C [ P ]

LOCATION: Av Bays  
PART NUMBER:

CAUSES: Component failure due to contamination or mechanical, thermal, or electrical overstress in MIA, ALU, MUX, Local Store, Memory, or DMA Queue

EFFECTS/RATIONALE:

Critical GPC/IOP inputs are validated thru parity checking. Recurring input errors result in either GPC "fail-to-sync" bringing down an erring GPC, or ignoring inputs from an erring MDM via a GPC mask. Erroneous inputs, if propagated through the GPC, could result in erroneous command outputs and loss of vehicle/life, if complete function was lost.

REFERENCES: JSC 18820, JSC 11174, JSC 12770

INDEPENDENT ORBITER ASSESSMENT  
ORBITER SUBSYSTEM ANALYSIS WORKSHEET

DATE:	10/03/86	HIGHEST CRITICALITY	HDW/FUNC
SUBSYSTEM:	DPS	FLIGHT:	3/1R
MDAC ID:	205	ABORT:	3/1R

ITEM: Central Processing Unit (CPU)  
FAILURE MODE: Loss of output

LEAD ANALYST: T. B. Cribbs                      SUBSYS LEAD: B. Robb

BREAKDOWN HIERARCHY:

- 1) DPS
- 2) General Purpose Computer (GPC)
- 3) Central Processing Unit (CPU)
- 4)
- 5)
- 6)
- 7)
- 8)
- 9)

FLIGHT PHASE	HDW/FUNC	ABORT	HDW/FUNC
PRELAUNCH:	3/3	RTLS:	3/1R
LIFTOFF:	3/1R	TAL:	3/1R
ONORBIT:	3/2R	AOA:	3/1R
DEORBIT:	3/1R	ATO:	3/1R
LANDING/SAFING:	3/1R		

REDUNDANCY SCREENS:    A [ 1 ]            B [ P ]            C [ P ]

LOCATION:            Av Bays  
PART NUMBER: .

CAUSES: CPU fails to function due to loss of power or failure of memory timing page

EFFECTS/RATIONALE:

In dynamic flight phases where redundant set (RS) is operating, other GPC's recognize GPC failing to sync and issue fail votes against it. The failing GPC's voting logic then removes it from the RS. Four RS GPC's control critical flight functions; if at least three are lost, the 5th GPC (backup flight computer, BFS) is engaged. Loss of BFS would result in loss of vehicle/life.

REFERENCES: JSC 18820, JSC 11174, JSC 12770

INDEPENDENT ORBITER ASSESSMENT  
ORBITER SUBSYSTEM ANALYSIS WORKSHEET

DATE: 10/03/86 HIGHEST CRITICALITY HDW/FUNC  
SUBSYSTEM: DPS FLIGHT: 3/1R  
MDAC ID: 206 ABORT: 3/1R

ITEM: Central Processing Unit (CPU)  
FAILURE MODE: Erroneous/erratic output

LEAD ANALYST: T. B. Cribbs SUBSYS LEAD: B. Robb

BREAKDOWN HIERARCHY:

- 1) DPS
- 2) General Purpose Computer (GPC)
- 3) Central Processing Unit (CPU)
- 4)
- 5)
- 6)
- 7)
- 8)
- 9)

CRITICALITIES			
FLIGHT PHASE	HDW/FUNC	ABORT	HDW/FUNC
PRELAUNCH:	3/2R	RTLS:	3/1R
LIFTOFF:	3/1R	TAL:	3/1R
ONORBIT:	3/3	AOA:	3/1R
DEORBIT:	3/1R	ATO:	3/1R
LANDING/SAFING:	3/1R		

REDUNDANCY SCREENS: A [ 1 ] B [ P ] C [ P ]

LOCATION: Av Bays  
PART NUMBER:

CAUSES: CPU outputs invalid data to IOP due to memory parity error, or failure of Master Bus Control, ALU, Data Flow Mux, or Local Store

EFFECTS/RATIONALE:

Critical GPC outputs are validated by sumword comparison to outputs from redundant GPC's; however, detected errors are merely logged and downlinked without corrective action. Invalid command outputs are passed through Bus Terminal Units (BTU's) to actuators which "force fight" the redundant commands in order to vote out the erroneous command. Loss of more than one output channel to the same actuator would require crew intervention, possibly causing instable switchover transients.

REFERENCES: JSC 18820, JSC 11174, JSC 12770

INDEPENDENT ORBITER ASSESSMENT  
ORBITER SUBSYSTEM ANALYSIS WORKSHEET

DATE: 10/03/86 HIGHEST CRITICALITY HDW/FUNC  
SUBSYSTEM: DPS FLIGHT: 3/1R  
MDAC ID: 207 ABORT: 3/1R

ITEM: Central Processing Unit (CPU)  
FAILURE MODE: Delayed/premature/inadvertent operation

LEAD ANALYST: T. B. Cribbs SUBSYS LEAD: B. Robb

BREAKDOWN HIERARCHY:

- 1) DPS
- 2) General Purpose Computer (GPC)
- 3) Central Processing Unit (CPU)
- 4)
- 5)
- 6)
- 7)
- 8)
- 9)

CRITICALITIES

FLIGHT PHASE	HDW/FUNC	ABORT	HDW/FUNC
PRELAUNCH:	3/2R	RTLS:	3/1R
LIFTOFF:	3/1R	TAL:	3/1R
ONORBIT:	3/3	AOA:	3/1R
DEORBIT:	3/1R	ATO:	3/1R
LANDING/SAFING:	3/1R		

REDUNDANCY SCREENS: A [ 1 ] B [ P ] C [ P ]

LOCATION: Av Bays  
PART NUMBER:

CAUSES: CPU attempts to output data at inappropriate time due to processor slow-down while servicing recurring I/O errors, failure of interrupt logic, or intermittence in timing page.

EFFECTS/RATIONALE:

Redundant Set GPC's synch up by waiting for synch point messages from other GPC's to indicate completion of identical operations. Excessive processor load could require all GPC's to wait excessively, but each GPC would recognize the slow down and issue a fail-to-synch vote, and the slow GPC's voting logic would remove it from the RS. If performance of all GPC's was degraded during dynamic flight phases, vehicle instability could occur unless crew took control.

REFERENCES: JSC 18820, JSC 11174, JSC 12770



INDEPENDENT ORBITER ASSESSMENT  
ORBITER SUBSYSTEM ANALYSIS WORKSHEET

DATE: 10/03/86 HIGHEST CRITICALITY HDW/FUNC  
SUBSYSTEM: DPS FLIGHT: 2/1R  
MDAC ID: 208 ABORT: 2/1R

ITEM: Central Processing Unit (CPU)  
FAILURE MODE: Inadvertent operation

LEAD ANALYST: T. B. Cribbs SUBSYS LEAD: B. Robb

BREAKDOWN HIERARCHY:

- 1) DPS
- 2) General Purpose Computer (GPC)
- 3) Central Processing Unit (CPU)
- 4)
- 5)
- 6)
- 7)
- 8)
- 9)

FLIGHT PHASE	CRITICALITIES		HDW/FUNC
	HDW/FUNC	ABORT	
PRELAUNCH:	3/3	RTLS:	2/1R
LIFTOFF:	2/1R	TAL:	2/1R
ONORBIT:	3/3	AOA:	2/1R
DEORBIT:	2/1R	ATO:	2/1R
LANDING/SAFING:	2/1R		

REDUNDANCY SCREENS: A [ 1 ] B [ P ] C [ P ]

LOCATION: Av Bays  
PART NUMBER:

CAUSES: CPU attempts to output data on incorrect data bus due to errors in memory locations containing configuration or bus-stringing parameters.

EFFECTS/RATIONALE:

Loss of memory in bus assignment table (NBAT) could result in a GPC attempting to command a data bus commanded by another GPC. Both examine their respective NBAT and assume no error condition, and continue transmission on that same bus. This would cause all data on that bus to be erroneous. Furthermore, idle bus is created and 2 command paths are lost. Possible to outvote good commands: loss of vehicle/life.

REFERENCES: JSC 18820, JSC 11174, JSC 12770

INDEPENDENT ORBITER ASSESSMENT  
ORBITER SUBSYSTEM ANALYSIS WORKSHEET

DATE: 10/03/86 HIGHEST CRITICALITY HDW/FUNC  
SUBSYSTEM: DPS FLIGHT: 3/3  
MDAC ID: 209 ABORT: 3/3

ITEM: CPU Power Switch  
FAILURE MODE: Fails closed

LEAD ANALYST: T. B. Cribbs SUBSYS LEAD: B. Robb

BREAKDOWN HIERARCHY:

- 1) DPS
- 2) General Purpose Computer (GPC)
- 3) Central Processing Unit (CPU)
- 4) CPU Power Switch
- 5)
- 6)
- 7)
- 8)
- 9)

CRITICALITIES

FLIGHT PHASE	HDW/FUNC	ABORT	HDW/FUNC
PRELAUNCH:	3/3	RTLS:	3/3
LIFTOFF:	3/3	TAL:	3/3
ONORBIT:	3/3	AOA:	3/3
DEORBIT:	3/3	ATO:	3/3
LANDING/SAFING:	3/3		

REDUNDANCY SCREENS: A [NA ] B [NA ] C [NA ]

LOCATION: Panel 06  
PART NUMBER:

CAUSES: CPU power switch is stuck in the "on" position due to contamination

EFFECTS/RATIONALE:

Flight rules dictate that the crew should power off any GPC which has recurring errors during dynamic flight phases, as soon as possible to avoid erroneous outputs being sent to actuators. If the CPU power switch were stuck in the "on" position and another GPC began sending erroneous data, the actuators could not vote out the erroneous commands and the crew would need to take manual control.

REFERENCES: JSC 18820, JSC 11174, JSC 12770

INDEPENDENT ORBITER ASSESSMENT  
ORBITER SUBSYSTEM ANALYSIS WORKSHEET

DATE: 10/03/86 HIGHEST CRITICALITY HDW/FUNC  
SUBSYSTEM: DPS FLIGHT: 3/1R  
MDAC ID: 210 ABORT: 3/1R

ITEM: GPC Mode Switch  
FAILURE MODE: Fails closed

LEAD ANALYST: T. B. Cribbs SUBSYS LEAD: B. Robb

BREAKDOWN HIERARCHY:

- 1) DPS
- 2) General Purpose Computer (GPC)
- 3) Central Processing Unit (CPU)
- 4) GPC Mode Switch
- 5)
- 6)
- 7)
- 8)
- 9)

CRITICALITIES			
FLIGHT PHASE	HDW/FUNC	ABORT	HDW/FUNC
PRELAUNCH:	3/3	RTLS:	3/1R
LIFTOFF:	3/1R	TAL:	3/1R
ONORBIT:	3/2R	AOA:	3/1R
DEORBIT:	3/1R	ATO:	3/1R
LANDING/SAFING:	3/1R		

REDUNDANCY SCREENS: A [ 1 ] B [ P ] C [ P ]

LOCATION: Panel O6  
PART NUMBER:

CAUSES: CPU mode switch is stuck in the "halt" or "standby" position due to contamination

EFFECTS/RATIONALE:

If the mode switch for a GPC were stuck in a non-run position the GPC would in effect be disabled, similar to failing to halt. The remaining GPC's would ignore this GPC, and the GPC would not be available as a backup or redundant member. If all GPC's were stuck in the standby mode, the crew could not perform critical flight control functions.

REFERENCES: JSC 18820, JSC 11174, JSC 12770

INDEPENDENT ORBITER ASSESSMENT  
ORBITER SUBSYSTEM ANALYSIS WORKSHEET

DATE:	10/03/86	HIGHEST CRITICALITY	HDW/FUNC
SUBSYSTEM:	DPS	FLIGHT:	3/1R
MDAC ID:	211	ABORT:	3/1R

ITEM: GPC Output Switch  
FAILURE MODE: Fails closed

LEAD ANALYST: T. B. Cribbs                      SUBSYS LEAD: B. Robb

BREAKDOWN HIERARCHY:

- 1) DPS
- 2) General Purpose Computer (GPC)
- 3) Central Processing Unit (CPU)
- 4) GPC Output Switch
- 5)
- 6)
- 7)
- 8)
- 9)

CRITICALITIES

FLIGHT PHASE	HDW/FUNC	ABORT	HDW/FUNC
PRELAUNCH:	3/3	RTLS:	3/1R
LIFTOFF:	3/1R	TAL:	3/1R
ONORBIT:	3/3	AOA:	3/1R
DEORBIT:	3/1R	ATO:	3/1R
LANDING/SAFING:	3/1R		

REDUNDANCY SCREENS:    A [ 1 ]            B [ P ]            C [ P ]

LOCATION:            Panel 06  
PART NUMBER:

CAUSES: CPU output switch is stuck in the "terminate" or "backup" position due to contamination

EFFECTS/RATIONALE:

If the Output Switch were stuck in the "terminate" position, this would have the same effect of disabling the GPC's output; all switches in this position would cause loss of vehicle control. If the switch were stuck in the "backup" position this GPC would only be available as BFS. If all switches in "backup" GPC 5 would be backup when engaged.

REFERENCES: JSC 18820, JSC 11174, JSC 12770

INDEPENDENT ORBITER ASSESSMENT  
ORBITER SUBSYSTEM ANALYSIS WORKSHEET

DATE: 10/03/86 HIGHEST CRITICALITY HDW/FUNC  
SUBSYSTEM: DPS FLIGHT: 3/1R  
MDAC ID: 213 ABORT: 3/1R

ITEM: GPC Power Switch  
FAILURE MODE: Fails open

LEAD ANALYST: T. B. Cribbs SUBSYS LEAD: B. Robb

BREAKDOWN HIERARCHY:

- 1) DPS
- 2) General Purpose Computer (GPC)
- 3) Central Processing Unit (CPU)
- 4) GPC Power Switch
- 5)
- 6)
- 7)
- 8)
- 9)

CRITICALITIES

FLIGHT PHASE	HDW/FUNC	ABORT	HDW/FUNC
PRELAUNCH:	3/3	RTLS:	3/1R
LIFTOFF:	3/1R	TAL:	3/1R
ONORBIT:	3/2R	AOA:	3/1R
DEORBIT:	3/1R	ATO:	3/1R
LANDING/SAFING:	3/1R		

REDUNDANCY SCREENS: A [ 1 ] B [ P ] C [ P ]

LOCATION: Panel 06  
PART NUMBER:

CAUSES: CPU power switch is stuck in "off" position, or GPC power is lost

EFFECTS/RATIONALE:

If the GPC power switch were stuck in the "OFF" position, the GPC could not function, same as CPU Loss of Output.

REFERENCES: JSC 18820, JSC 11174, JSC 12770

INDEPENDENT ORBITER ASSESSMENT  
ORBITER SUBSYSTEM ANALYSIS WORKSHEET

DATE: 10/20/86 HIGHEST CRITICALITY HDW/FUNC  
SUBSYSTEM: DPS FLIGHT: 3/3  
MDAC ID: 214 ABORT: /NA

ITEM: DRIVER MODULE CONTROLLER  
FAILURE MODE: PREMATURE OUTPUT

LEAD ANALYST: B. ROBB SUBSYS LEAD: B. ROBB

BREAKDOWN HIERARCHY:

- 1) DPS
- 2) GENERAL PURPOSE COMPUTER (GPC)
- 3) POWER DISTRIBUTION
- 4) DRIVER MODULE CONTROLLER
- 5)
- 6)
- 7)
- 8)
- 9)

CRITICALITIES

FLIGHT PHASE	HDW/FUNC	ABORT	HDW/FUNC
PRELAUNCH:	3/3	RTLS:	/NA
LIFTOFF:	/NA	TAL:	/NA
ONORBIT:	/NA	AOA:	/NA
DEORBIT:	/NA	ATO:	/NA
LANDING/SAFING:	/NA		

REDUNDANCY SCREENS: A [NA ] B [NA ] C [NA ]

LOCATION:  
PART NUMBER:

CAUSES: INTERNAL COMPONENT FAILURE

EFFECTS/RATIONALE:

PREMATURE OPERATION CAUSES POWER TO BE APPLIED TO A GPC. NO  
HARMFUL EFFECTS TO POWER UP A GPC.

REFERENCES:

INDEPENDENT ORBITER ASSESSMENT  
ORBITER SUBSYSTEM ANALYSIS WORKSHEET

DATE: 10/20/86 HIGHEST CRITICALITY HDW/FUNC  
SUBSYSTEM: DPS FLIGHT: 3/1R  
MDAC ID: 215 ABORT: 3/1R

ITEM: DRIVER MODULE CONTROLLER  
FAILURE MODE: NO OUTPUT

LEAD ANALYST: B. ROBB SUBSYS LEAD: B. ROBB

BREAKDOWN HIERARCHY:

- 1) DPS
- 2) GENERAL PURPOSE COMPUTER (GPC)
- 3) POWER DISTRIBUTION
- 4) DRIVER MODULE CONTROLLER
- 5)
- 6)
- 7)
- 8)
- 9)

FLIGHT PHASE	CRITICALITIES		HDW/FUNC
	HDW/FUNC	ABORT	
PRELAUNCH:	3/1R	RTLS:	3/1R
LIFTOFF:	3/1R	TAL:	3/1R
ONORBIT:	3/1R	AOA:	3/1R
DEORBIT:	3/1R	ATO:	3/1R
LANDING/SAFING:	3/1R		

REDUNDANCY SCREENS: A [ 1 ] B [ P ] C [ P ]

LOCATION:  
PART NUMBER:

CAUSES: INTERNAL COMPONENT

EFFECTS/RATIONALE:  
LOSS ONE OF THREE REDUNDANT POWER SOURSES TO A GPC.

REFERENCES:

INDEPENDENT ORBITER ASSESSMENT  
ORBITER SUBSYSTEM ANALYSIS WORKSHEET

DATE: 10/20/86 HIGHEST CRITICALITY HDW/FUNC  
SUBSYSTEM: DPS FLIGHT: 3/3  
MDAC ID: 216 ABORT: 3/3

ITEM: SWITCH, GPC POWER  
FAILURE MODE: PREMATURE CLOSURE

LEAD ANALYST: B. ROBB SUBSYS LEAD: B. ROBB

BREAKDOWN HIERARCHY:

- 1) DPS
- 2) GENERAL PURPOSE COMPUTER (GPC)
- 3) POWER DISTRIBUTION
- 4) SWITCH, GPC POWER
- 5)
- 6)
- 7)
- 8)
- 9)

CRITICALITIES

FLIGHT PHASE	HDW/FUNC	ABORT	HDW/FUNC
PRELAUNCH:	3/3	RTLS:	3/3
LIFTOFF:	3/3	TAL:	3/3
ONORBIT:	3/3	AOA:	3/3
DEORBIT:	3/3	ATO:	3/3
LANDING/SAFING:	3/3		

REDUNDANCY SCREENS: A [NA ] B [NA ] C [NA ]

LOCATION:  
PART NUMBER:

CAUSES: VIBRATION, PIECE PART FAILURE

EFFECTS/RATIONALE:

THE MAIN DC POWER IS APPLIED TO THE GPC. NO HARMFUL EFFECTS TO APPLY POWER TO A GPC.

REFERENCES:



INDEPENDENT ORBITER ASSESSMENT  
ORBITER SUBSYSTEM ANALYSIS WORKSHEET

DATE: 10/20/86 HIGHEST CRITICALITY HDW/FUNC  
SUBSYSTEM: DPS FLIGHT: 2/1R  
MDAC ID: 217 ABORT: 2/1R

ITEM: SWITCH, GPC POWER  
FAILURE MODE: FAILS OPEN

LEAD ANALYST: B. ROBB SUBSYS LEAD: B. ROBB

BREAKDOWN HIERARCHY:

- 1) DPS
- 2) GENERAL PURPOSE COMPUTER (GPC)
- 3) POWER DISTRIBUTION
- 4) SWITCH, GPC POWER
- 5)
- 6)
- 7)
- 8)
- 9)

CRITICALITIES

FLIGHT PHASE	HDW/FUNC	ABORT	HDW/FUNC
PRELAUNCH:	2/1R	RTLS:	2/1R
LIFTOFF:	2/1R	TAL:	2/1R
ONORBIT:	2/1R	AOA:	2/1R
DEORBIT:	2/1R	ATO:	2/1R
LANDING/SAFING:	2/1R		

REDUNDANCY SCREENS: A [ 1 ] B [ P ] C [ P ]

LOCATION:  
PART NUMBER:

CAUSES: VIBRATION, PIECE PART FAILURE

EFFECTS/RATIONALE:

POSSIBLE MISSION TERMINATION ON FIRST FAILURE. SECOND FAILURE  
COULD CAUSE LOSS OF CREW AND VEHICLE. IF FAILURE OCCURS CLOSE TO  
MECO THERE IS NOT ENOUGH TIME TO MANUALLY SHUT DOWN ENGINES TO  
PREVENT CAVITATION.

REFERENCES:

INDEPENDENT ORBITER ASSESSMENT  
ORBITER SUBSYSTEM ANALYSIS WORKSHEET

DATE: 10/20/86 HIGHEST CRITICALITY HDW/FUNC  
SUBSYSTEM: DPS FLIGHT: 3/3  
MDAC ID: 218 ABORT: 3/3

ITEM: STATUS LIGHT  
FAILURE MODE: NO OUTPUT

LEAD ANALYST: B. ROBB SUBSYS LEAD: B. ROBB

BREAKDOWN HIERARCHY:

- 1) DPS
- 2) GENERAL PURPOSE COMPUTER (GPC)
- 3) GENERAL PROCESSING UNIT (CPU)
- 4) STATUS LIGHT
- 5)
- 6)
- 7)
- 8)
- 9)

FLIGHT PHASE	CRITICALITIES		HDW/FUNC
	HDW/FUNC	ABORT	
PRELAUNCH:	3/3	RTLS:	3/3
LIFTOFF:	3/3	TAL:	3/3
ONORBIT:	3/3	AOA:	3/3
DEORBIT:	3/3	ATO:	3/3
LANDING/SAFING:	3/3		

REDUNDANCY SCREENS: A [NA ] B [NA ] C [NA ]

LOCATION:  
PART NUMBER:

CAUSES: FILAMENT FAILURE, VIBRATION

EFFECTS/RATIONALE:  
NO EFFECT. CRT DISPLAYS GPC STATUS, BARBER POLE INDICATES OUTPUT OF FAILED GPC IS TERMINATED.

REFERENCES:

INDEPENDENT ORBITER ASSESSMENT  
ORBITER SUBSYSTEM ANALYSIS WORKSHEET

DATE: 10/20/86 HIGHEST CRITICALITY HDW/FUNC  
SUBSYSTEM: DPS FLIGHT: 3/3  
MDAC ID: 219 ABORT: 3/3

ITEM: CICU  
FAILURE MODE: NO OUTPUT

LEAD ANALYST: B. ROBB SUBSYS LEAD: B. ROBB

BREAKDOWN HIERARCHY:

- 1) DPS
- 2) GENERAL PURPOSE COMPUTER (GPC)
- 3) GENERAL PROCESSING UNIT (CPU)
- 4) COMPUTER INTERFACE CONDITIONING UNIT (CICU)
- 5)
- 6)
- 7)
- 8)
- 9)

CRITICALITIES			
FLIGHT PHASE	HDW/FUNC	ABORT	HDW/FUNC
PRELAUNCH:	3/3	RTLS:	3/3
LIFTOFF:	3/3	TAL:	3/3
ONORBIT:	3/3	AOA:	3/3
DEORBIT:	3/3	ATO:	3/3
LANDING/SAFING:	3/3		

REDUNDANCY SCREENS: A [NA ] B [NA ] C [NA ]

LOCATION:  
PART NUMBER:

CAUSES: INTERNAL COMPONENT FAILURE, VIBRATION

EFFECTS/RATIONALE:

NO EFFECT. LOSS OF CONVERSION POWER TO DRIVE GPC STATUS LIGHTS HAS SAME EFFECT AS LOSS OF STATUS LIGHT. OTHER INDICATORS PROVIDE GPC HEALTH STATUS.

REFERENCES:

INDEPENDENT ORBITER ASSESSMENT  
ORBITER SUBSYSTEM ANALYSIS WORKSHEET

DATE: 10/20/86 HIGHEST CRITICALITY HDW/FUNC  
SUBSYSTEM: DPS FLIGHT: 3/2R  
MDAC ID: 220 ABORT: 3/2R

ITEM: SWITCH, IPL  
FAILURE MODE: PREMATURE OPERATION

LEAD ANALYST: B. ROBB SUBSYS LEAD: B. ROBB

BREAKDOWN HIERARCHY:

- 1) DPS
- 2) GENERAL PURPOSE COMPUTER (GPC)
- 3) SWITCH, IPL
- 4)
- 5)
- 6)
- 7)
- 8)
- 9)

CRITICALITIES

FLIGHT PHASE	HDW/FUNC	ABORT	HDW/FUNC
PRELAUNCH:	3/2R	RTLS:	3/2R
LIFTOFF:	3/2R	TAL:	3/2R
ONORBIT:	3/2R	AOA:	3/2R
DEORBIT:	3/2R	ATO:	3/2R
LANDING/SAFING:	3/2R		

REDUNDANCY SCREENS: A [ 1 ] B [ P ] C [ P ]

LOCATION:  
PART NUMBER:

CAUSES: VIBRATION, PIECE PART FAILURE

EFFECTS/RATIONALE:

NO EFFECT IF GPC IS IN RUN OR STANDBY MODE. IPL NOT NECESSARY  
IN-FLIGHT UNLESS ANOTHER FAILURE OCCURS TO GPC FIRST.

REFERENCES:

INDEPENDENT ORBITER ASSESSMENT  
ORBITER SUBSYSTEM ANALYSIS WORKSHEET

DATE: 10/20/86 HIGHEST CRITICALITY HDW/FUNC  
SUBSYSTEM: DPS FLIGHT: 3/3  
MDAC ID: 221 ABORT: 3/3

ITEM: INDICATOR, IPL  
FAILURE MODE: PREMATURE OPERATION

LEAD ANALYST: B. ROBB SUBSYS LEAD: B. ROBB

BREAKDOWN HIERARCHY:

- 1) DPS
- 2) GENERAL PURPOSE COMPUTER (GPC)
- 3) INDICATOR, IPL
- 4)
- 5)
- 6)
- 7)
- 8)
- 9)

CRITICALITIES

FLIGHT PHASE	HDW/FUNC	ABORT	HDW/FUNC
PRELAUNCH:	3/3	RTLS:	3/3
LIFTOFF:	3/3	TAL:	3/3
ONORBIT:	3/3	AOA:	3/3
DEORBIT:	3/3	ATO:	3/3
LANDING/SAFING:	3/3		

REDUNDANCY SCREENS: A [NA ] B [NA ] C [NA ]

LOCATION:  
PART NUMBER:

CAUSES: VIBRATION, SHOCK

EFFECTS/RATIONALE:

A FALSE INDICATOR OF THE IPL FUNCTION HAS NO EFFECT ON THE GPC.  
IPL FUNCTION CAN BE MONITORED ON COMPUTER ANNUNCIATOR PANEL FOR  
GPC STATUS.

REFERENCES:

INDEPENDENT ORBITER ASSESSMENT  
ORBITER SUBSYSTEM ANALYSIS WORKSHEET

DATE: 10/20/86 HIGHEST CRITICALITY HDW/FUNC  
SUBSYSTEM: DPS FLIGHT: 3/3  
MDAC ID: 222 ABORT: 3/3

ITEM: INDICATOR, IPL  
FAILURE MODE: FAILS TO TRANSFER INDICATION OF GPC MODE

LEAD ANALYST: B. ROBB SUBSYS LEAD: B. ROBB

BREAKDOWN HIERARCHY:

- 1) DPS
- 2) GENERAL PURPOSE COMPUTER (GPC)
- 3) INDICATOR, IPL
- 4)
- 5)
- 6)
- 7)
- 8)
- 9)

CRITICALITIES

FLIGHT PHASE	HDW/FUNC	ABORT	HDW/FUNC
PRELAUNCH:	3/3	RTLS:	3/3
LIFTOFF:	3/3	TAL:	3/3
ONORBIT:	3/3	AOA:	3/3
DEORBIT:	3/3	ATO:	3/3
LANDING/SAFING:	3/3		

REDUNDANCY SCREENS: A [NA ] B [NA ] C [NA ]

LOCATION:  
PART NUMBER:

CAUSES: VIBRATION, SHOCK

EFFECTS/RATIONALE:  
AN ERRONEOUS INDICATION OF THE GPC STATUS WILL BE DISPLAYED. NO  
EFFECT ON THE GPC'S FUNCTIONS.

REFERENCES:

INDEPENDENT ORBITER ASSESSMENT  
ORBITER SUBSYSTEM ANALYSIS WORKSHEET

DATE: 10/20/86 HIGHEST CRITICALITY HDW/FUNC  
SUBSYSTEM: DPS FLIGHT: 3/3  
MDAC ID: 223 ABORT: 3/3

ITEM: INDICATOR OUTPUT, BARBER POLE  
FAILURE MODE: ERRONEOUS INDICATION

LEAD ANALYST: B. ROBB SUBSYS LEAD: B. ROBB

BREAKDOWN HIERARCHY:

- 1) DPS
- 2) GENERAL PURPOSE COMPUTER (GPC)
- 3) INDICATOR OUTPUT
- 4)
- 5)
- 6)
- 7)
- 8)
- 9)

CRITICALITIES			
FLIGHT PHASE	HDW/FUNC	ABORT	HDW/FUNC
PRELAUNCH:	3/3	RTLS:	3/3
LIFTOFF:	3/3	TAL:	3/3
ONORBIT:	3/3	AOA:	3/3
DEORBIT:	3/3	ATO:	3/3
LANDING/SAFING:	3/3		

REDUNDANCY SCREENS: A [NA ] B [NA ] C [NA ]

LOCATION:  
PART NUMBER:

CAUSES: FAILED DRIVER, SHOCK, VIBRATION

EFFECTS/RATIONALE:  
INDICATES ERRONEOUS GPC STATUS. NO EFFECT OF GPC FUNCTION. GPC  
STATUS DISPLAYED ON GPC STATUS ANNUNCIATOR.

REFERENCES:

INDEPENDENT ORBITER ASSESSMENT  
ORBITER SUBSYSTEM ANALYSIS WORKSHEET

DATE: 10/20/86 HIGHEST CRITICALITY HDW/FUNC  
SUBSYSTEM: DPS FLIGHT: 3/3  
MDAC ID: 224 ABORT: 3/3

ITEM: INDICATOR OUTPUT, BARBER POLE  
FAILURE MODE: FAILS TO TRANSFER

LEAD ANALYST: B. ROBB SUBSYS LEAD: B. ROBB

BREAKDOWN HIERARCHY:

- 1) DPS
- 2) GENERAL PURPOSE COMPUTER (GPC)
- 3) INDICATOR OUTPUT
- 4)
- 5)
- 6)
- 7)
- 8)
- 9)

CRITICALITIES

FLIGHT PHASE	HDW/FUNC	ABORT	HDW/FUNC
PRELAUNCH:	3/3	RTLS:	3/3
LIFTOFF:	3/3	TAL:	3/3
ONORBIT:	3/3	AOA:	3/3
DEORBIT:	3/3	ATO:	3/3
LANDING/SAFING:	3/3		

REDUNDANCY SCREENS: A [NA ] B [NA ] C [NA ]

LOCATION:  
PART NUMBER:

CAUSES: VIBRATION, SHOCK, PIECE PART FAILURE

EFFECTS/RATIONALE:  
ERRONEOUS INDICATION OF GPC STATUS. GPC STATUS ANNUNCIATOR CAN  
BE MONITORED OF GPC STATUS.

REFERENCES:



INDEPENDENT ORBITER ASSESSMENT  
ORBITER SUBSYSTEM ANALYSIS WORKSHEET

DATE: 10/24/86 HIGHEST CRITICALITY HDW/FUNC  
SUBSYSTEM: DPS FLIGHT: 2/1R  
MDAC ID: 225 ABORT: 2/1R

ITEM: INPUT/OUTPUT PROCESSOR (IOP)  
FAILURE MODE: ERRONEOUS OUTPUT

LEAD ANALYST: B. ROBB SUBSYS LEAD: B. ROBB

BREAKDOWN HIERARCHY:

- 1) DPS
- 2) GENERAL PURPOSE COMPUTER
- 3) INPUT/OUTPUT PROCESSOR (IOP)
- 4)
- 5)
- 6)
- 7)
- 8)
- 9)

CRITICALITIES			
FLIGHT PHASE	HDW/FUNC	ABORT	HDW/FUNC
PRELAUNCH:	2/1R	RTLS:	2/1R
LIFTOFF:	2/1R	TAL:	2/1R
ONORBIT:	2/1R	AOA:	2/1R
DEORBIT:	2/1R	ATO:	2/1R
LANDING/SAFING:	2/1R		

REDUNDANCY SCREENS: A [ 1 ] B [ P ] C [ P ]

LOCATION:  
PART NUMBER:

CAUSES: INTERNAL COMPONENT FAILURE

EFFECTS/RATIONALE:

MAY EXECUTE COMMAND TO WRONG MDM WITH ADDRESS ERROR. THE WORST CASE WOULD BE TO AN UNVOTED EFFECTOR. NO EFFECT ON 1ST FAILURE. CREW CAN PRECLUDE SENSITIVITY TO 2ND FAILURE.

REFERENCES:

INDEPENDENT ORBITER ASSESSMENT  
ORBITER SUBSYSTEM ANALYSIS WORKSHEET

DATE: 10/30/86 HIGHEST CRITICALITY HDW/FUNC  
SUBSYSTEM: DPS FLIGHT: /NA  
MDAC ID: 226 ABORT: /NA

ITEM: RESISTOR  
FAILURE MODE: NOT APPLICABLE

LEAD ANALYST: H J LOWERY SUBSYS LEAD: B. ROBB

BREAKDOWN HIERARCHY:

- 1) DPS
- 2) GPC
- 3) RESISTOR
- 4)
- 5)
- 6)
- 7)
- 8)
- 9)

CRITICALITIES

FLIGHT PHASE	HDW/FUNC	ABORT	HDW/FUNC
PRELAUNCH:	/NA	RTLS:	/NA
LIFTOFF:	/NA	TAL:	/NA
ONORBIT:	/NA	AOA:	/NA
DEORBIT:	/NA	ATO:	/NA
LANDING/SAFING:	/NA		

REDUNDANCY SCREENS: A [NA ] B [NA ] C [NA ]

LOCATION:  
PART NUMBER:

CAUSES: RESISTOR HAS BEEN REPLACED WITH A FUSE.

EFFECTS/RATIONALE:  
THIS RESISTOR HAS BEEN REPLACED WITH PART NUMBER ME451-0018-0300  
(SEE FMEA #05-6S-BFUS1-1)

REFERENCES: FMEA NO. 05-6S-BRES1-1. NASA-JSC FMEA CIL REVIEW  
COMMENTS.

INDEPENDENT ORBITER ASSESSMENT  
ORBITER SUBSYSTEM ANALYSIS WORKSHEET

DATE: 10/30/86 HIGHEST CRITICALITY HDW/FUNC  
SUBSYSTEM: DPS FLIGHT: 3/1R  
MDAC ID: 227 ABORT: 3/1R

ITEM: FUSE  
FAILURE MODE: OPEN

LEAD ANALYST: H J LOWERY SUBSYS LEAD: B. ROBB

BREAKDOWN HIERARCHY:

- 1) DPS
- 2) GPC
- 3) FUSE
- 4)
- 5)
- 6)
- 7)
- 8)
- 9)

CRITICALITIES			
FLIGHT PHASE	HDW/FUNC	ABORT	HDW/FUNC
PRELAUNCH:	3/1R	RTLS:	3/1R
LIFTOFF:	3/1R	TAL:	3/1R
ONORBIT:	3/1R	AOA:	3/1R
DEORBIT:	3/1R	ATO:	3/1R
LANDING/SAFING:	3/1R		

REDUNDANCY SCREENS: A [ 1 ] B [ P ] C [ P ]

LOCATION:  
PART NUMBER:

CAUSES: MECHANICAL FRACTURE

EFFECTS/RATIONALE:

REFERENCES: FMEA NO. 05-6S-BFUS1-1

INDEPENDENT ORBITER ASSESSMENT  
ORBITER SUBSYSTEM ANALYSIS WORKSHEET

DATE: 10/30/86 HIGHEST CRITICALITY HDW/FUNC  
SUBSYSTEM: DPS FLIGHT: 3/1R  
MDAC ID: 228 ABORT: 3/1R

ITEM: CONTROLLER, REMOTE POWER  
FAILURE MODE: LOSS OF OUTPUT

LEAD ANALYST: H J LOWERY SUBSYS LEAD: B. ROBB

BREAKDOWN HIERARCHY:

- 1) DPS
- 2) GPC
- 3) CONTROLLER, REMOTE POWER
- 4)
- 5)
- 6)
- 7)
- 8)
- 9)

CRITICALITIES			
FLIGHT PHASE	HDW/FUNC	ABORT	HDW/FUNC
PRELAUNCH:	3/1R	RTLS:	3/1R
LIFTOFF:	3/1R	TAL:	3/1R
ONORBIT:	3/1R	AOA:	3/1R
DEORBIT:	3/1R	ATO:	3/1R
LANDING/SAFING:	3/1R		

REDUNDANCY SCREENS: A [ 1 ] B [ P ] C [ P ]

LOCATION:  
PART NUMBER:

CAUSES: TEMPERATURE STRESS, MECHANICAL FRACTURES, CONTAMINATION,  
DEBRIS

EFFECTS/RATIONALE:  
ONE OF THREE REDUNDANT RPC IS DISABLED.

REFERENCES: FMEA NO. 05-6S-BRPC-1. NASA JSC FMEA CIL REVIEW  
COMMENTS.

INDEPENDENT ORBITER ASSESSMENT  
ORBITER SUBSYSTEM ANALYSIS WORKSHEET

DATE: 10/30/86 HIGHEST CRITICALITY HDW/FUNC  
SUBSYSTEM: DPS FLIGHT: 3/3  
MDAC ID: 229 ABORT: 3/3

ITEM: CONTROLLER, REMOTE POWER  
FAILURE MODE: CONDUCTS PREMATURELY

LEAD ANALYST: H J LOWERY SUBSYS LEAD: B. ROBB

BREAKDOWN HIERARCHY:

- 1) DPS
- 2) GPC
- 3) CONTROLLER, REMOTE POWER
- 4)
- 5)
- 6)
- 7)
- 8)
- 9)

CRITICALITIES			
FLIGHT PHASE	HDW/FUNC	ABORT	HDW/FUNC
PRELAUNCH:	3/3	RTLS:	3/3
LIFTOFF:	3/3	TAL:	3/3
ONORBIT:	3/3	AOA:	3/3
DEORBIT:	3/3	ATO:	3/3
LANDING/SAFING:	3/3		

REDUNDANCY SCREENS: A [NA ] B [NA ] C [NA ]

LOCATION:  
PART NUMBER:

CAUSES: TEMPERATURE STRESS, MECHANICAL FRACTURE, CONTAMINATION,  
DEBRIS

EFFECTS/RATIONALE:  
NONE. POWER WOULD BE APPLIED PREMATURELY.

REFERENCES: FMEA NO. 05-6S-BRPC1-2. NASA-JSC FMEA CIL REVIEW  
COMMENTS.

INDEPENDENT ORBITER ASSESSMENT  
ORBITER SUBSYSTEM ANALYSIS WORKSHEET

DATE: 11/03/86 HIGHEST CRITICALITY HDW/FUNC  
SUBSYSTEM: DPS FLIGHT: 3/1R  
MDAC ID: 230 ABORT: 3/1R

ITEM: DIODE  
FAILURE MODE: FAILS OPEN

LEAD ANALYST: H J LOWERY SUBSYS LEAD: B. ROBB

BREAKDOWN HIERARCHY:

- 1) DPS
- 2) GPC
- 3) DIODE
- 4)
- 5)
- 6)
- 7)
- 8)
- 9)

CRITICALITIES

FLIGHT PHASE	HDW/FUNC	ABORT	HDW/FUNC
PRELAUNCH:	3/1R	RTLS:	3/1R
LIFTOFF:	3/1R	TAL:	3/1R
ONORBIT:	3/1R	AOA:	3/1R
DEORBIT:	3/1R	ATO:	3/1R
LANDING/SAFING:	3/1R		

REDUNDANCY SCREENS: A [ 1 ] B [ F ] C [ P ]

LOCATION:  
PART NUMBER:

CAUSES: THERMAL STRESS, CONTAMINATION, DEBRIS

EFFECTS/RATIONALE:

NONE ON FIRST/SECOND FAILURE. THREE RPC OUTPUTS ARE "OR" TOGETHER TO PROVIDE TRIPLY REDUNDANT POWER PATH TO CPU AND IOP. THREE FAILURES COULD CAUSE LOSS OF GPC.

REFERENCES: 05-6S-BDIOX-1. NASA-JSC FMEA & CIL REVIEW COMMENTS.

INDEPENDENT ORBITER ASSESSMENT  
ORBITER SUBSYSTEM ANALYSIS WORKSHEET

DATE: 11/03/86 HIGHEST CRITICALITY HDW/FUNC  
SUBSYSTEM: DPS FLIGHT: 3/1R  
MDAC ID: 231 ABORT: 3/1R

ITEM: SWITCH, NORMAL-TERM BACK-UP  
FAILURE MODE: PREMATURE OPERATION

LEAD ANALYST: H J LOWERY SUBSYS LEAD: B. ROBB

BREAKDOWN HIERARCHY:

- 1) DPS
- 2) GPC
- 3) SWITCH, NORMAL-TERM BACKUP
- 4)
- 5)
- 6)
- 7)
- 8)
- 9)

FLIGHT PHASE	CRITICALITIES		HDW/FUNC
	HDW/FUNC	ABORT	
PRELAUNCH:	3/1R	RTLS:	3/1R
LIFTOFF:	3/1R	TAL:	3/1R
ONORBIT:	3/1R	AOA:	3/1R
DEORBIT:	3/1R	ATO:	3/1R
LANDING/SAFING:	3/1R		

REDUNDANCY SCREENS: A [ 1 ] B [ P ] C [ P ]

LOCATION:  
PART NUMBER:

CAUSES: THERMAL STRESS, CONTAMINATION, DEBRIS

EFFECTS/RATIONALE:  
WILL TERMINATE FC DATA BUS I/O ACTIVITY OF A GOOD GPC.

REFERENCES: FMEA 05-5-B15-1-1

INDEPENDENT ORBITER ASSESSMENT  
ORBITER SUBSYSTEM ANALYSIS WORKSHEET

DATE: 10/20/86 HIGHEST CRITICALITY HDW/FUNC  
SUBSYSTEM: DPS FLIGHT: 3/1R  
MDAC ID: 232 ABORT: 3/1R

ITEM: SWITCH, GPC POWER  
FAILURE MODE: NO OUTPUT

LEAD ANALYST: B. ROBB SUBSYS LEAD: B. ROBB

BREAKDOWN HIERARCHY:

- 1) DPS
- 2) GENERAL PURPOSE COMPUTER (GPC)
- 3) POWER DISTRIBUTION
- 4) DRIVER MODULE CONTROLLER
- 5)
- 6)
- 7)
- 8)
- 9)

CRITICALITIES

FLIGHT PHASE	HDW/FUNC	ABORT	HDW/FUNC
PRELAUNCH:	3/1R	RTLS:	3/1R
LIFTOFF:	3/1R	TAL:	3/1R
ONORBIT:	3/1R	AOA:	3/1R
DEORBIT:	3/1R	ATO:	3/1R
LANDING/SAFING:	3/1R		

REDUNDANCY SCREENS: A [ 1 ] B [ P ] C [ P ]

LOCATION:  
PART NUMBER:

CAUSES: INTERNAL COMPONENT

EFFECTS/RATIONALE:  
LOSS ONE OF THREE REDUNDANT POWER SOURSES TO A GPC.

REFERENCES:



INDEPENDENT ORBITER ASSESSMENT  
ORBITER SUBSYSTEM ANALYSIS WORKSHEET

DATE: 10/03/86 HIGHEST CRITICALITY HDW/FUNC  
SUBSYSTEM: DPS FLIGHT: 3/1R  
MDAC ID: 300 ABORT: 3/1R

ITEM: KEYBOARD SWITCH  
FAILURE MODE: OPEN/CLOSED

LEAD ANALYST: H J LOWERY SUBSYS LEAD: B. ROBB

BREAKDOWN HIERARCHY:

- 1) DPS
- 2) MULTIFUNCTIONAL CRT DISPLAY SYSTEM (MCDS)
- 3) KEYBOARD
- 4) SWITCH
- 5)
- 6)
- 7)
- 8)
- 9)

CRITICALITIES			
FLIGHT PHASE	HDW/FUNC	ABORT	HDW/FUNC
PRELAUNCH:	3/2R	RTLS:	3/1R
LIFTOFF:	3/1R	TAL:	3/1R
ONORBIT:	3/1R	AOA:	3/1R
DEORBIT:	3/1R	ATO:	3/1R
LANDING/SAFEING:	3/1R		

REDUNDANCY SCREENS: A [ 1 ] B [ P ] C [ P ]

LOCATION: UPPER CREW AREA  
PART NUMBER:

CAUSES: MECHANICAL FRACTURE/ CONTAMINATION/ DEBRIS

EFFECTS/RATIONALE:

LOSS OF INPUTTING COMMAND CAPABILITY. REDUNDANT HARDWARE WOULD NOT BE ACCESSIBLE DURING PERIODS OF ANTICIPATED HIGH ACCELERATION/DEACCELERATION FORCES.  
ie. 1. LIFT-OFF THROUGH MAIN ENGINE CUT-OFF - APPROXIMATELY 8 MIN 40 SEC; 2. ENTRY THROUGH SAFEING -APPROXIMATELY 400,000ft (TD -40 MIN) THROUGH SAFEING.

REFERENCES:

INDEPENDENT ORBITER ASSESSMENT  
ORBITER SUBSYSTEM ANALYSIS WORKSHEET

DATE: 10/03/86 HIGHEST CRITICALITY HDW/FUNC  
SUBSYSTEM: DPS FLIGHT: 3/1R  
MDAC ID: 301 ABORT: 3/1R

ITEM: X/Y DEFLECTION AMPLIFIERS  
FAILURE MODE: NO OUTPUT/ERRONEOUS/ERRATIC OUTPUT

LEAD ANALYST: H J LOWERY SUBSYS LEAD: B. ROBB

BREAKDOWN HIERARCHY:

- 1) DPS
- 2) MULTIFUNCTIONAL CRT DISPLAY SYSTEM (MCDS)
- 3) DISPLAY UNIT
- 4) X/Y DEFLECTION AMPLIFIERS
- 5)
- 6)
- 7)
- 8)
- 9)

CRITICALITIES

FLIGHT PHASE	HDW/FUNC	ABORT	HDW/FUNC
PRELAUNCH:	3/2R	RTLS:	3/1R
LIFTOFF:	3/1R	TAL:	3/1R
ONORBIT:	3/1R	AOA:	3/1R
DEORBIT:	3/1R	ATO:	3/1R
LANDING/SAFEING:	3/1R		

REDUNDANCY SCREENS: A [ 1 ] B [ P ] C [ P ]

LOCATION: UPPER CREW AREA  
PART NUMBER:

CAUSES: TEMPERATURE STRESS/ CONTAMINATION/ DEBRIS

EFFECTS/RATIONALE:

LOSS OF MONITORING CAPABILITY. REDUNDANT HARDWARE WOULD NOT BE ACCESSIBLE DURING PERIODS OF ANTICIPATED HIGH ACCELERATION/DEACCELERATION FORCES.

ie. 1. LIFT-OFF THROUGH MAIN ENGINE CUT-OFF - APPROXIMATELY 8 MIN 40 SEC; 2. ENTRY THROUGH SAFEING -APPROXIMATELY 400,000ft (TD -40 MIN) THROUGH SAFEING.

REFERENCES:

INDEPENDENT ORBITER ASSESSMENT  
ORBITER SUBSYSTEM ANALYSIS WORKSHEET

DATE: 10/03/86 HIGHEST CRITICALITY HDW/FUNC  
SUBSYSTEM: DPS FLIGHT: 3/1R  
MDAC ID: 302 ABORT: 3/1R

ITEM: VIDEO AMPLIFIER  
FAILURE MODE: NO OUTPUT/ERRONEOUS/ERRATIC OUTPUT

LEAD ANALYST: H J LOWERY SUBSYS LEAD: B. ROBB

BREAKDOWN HIERARCHY:

- 1) DPS
- 2) MULTIFUNCTIONAL CRT DISPLAY SYSTEM (MCDS)
- 3) DISPLAY UNIT
- 4) VIDEO AMPLIFIER
- 5)
- 6)
- 7)
- 8)
- 9)

CRITICALITIES

FLIGHT PHASE	HDW/FUNC	ABORT	HDW/FUNC
PRELAUNCH:	3/2R	RTLS:	3/1R
LIFTOFF:	3/1R	TAL:	3/1R
ONORBIT:	3/1R	AOA:	3/1R
DEORBIT:	3/1R	ATO:	3/1R
LANDING/SAFEING:	3/1R		

REDUNDANCY SCREENS: A [ 1 ] B [ P ] C [ P ]

LOCATION: UPPER CREW AREA  
PART NUMBER:

CAUSES: TEMPERATURE STRESS/ CONTAMINATION/ DEBRIS

EFFECTS/RATIONALE:

LOSS OF MONITORING CAPABILITY. REDUNDANT HARDWARE WOULD NOT BE ACCESSIBLE DURING PERIODS OF ANTICIPATED HIGH ACCELERATION/DEACCELERATION FORCES.

ie. 1. LIFT-OFF THROUGH MAIN ENGINE CUT-OFF - APPROXIMATELY 8 MIN 40 SEC; 2. ENTRY THROUGH SAFEING -APPROXIMATELY 400,000ft (TD -40 MIN) THROUGH SAFEING.

REFERENCES:

INDEPENDENT ORBITER ASSESSMENT  
ORBITER SUBSYSTEM ANALYSIS WORKSHEET

DATE: 10/03/86 HIGHEST CRITICALITY HDW/FUNC  
SUBSYSTEM: DPS FLIGHT: 3/1R  
MDAC ID: 303 ABORT: 3/1R

ITEM: CATHODE-RAY TUBE  
FAILURE MODE: NO OUTPUT/ERRONEOUS/ERRATIC OUTPUT

LEAD ANALYST: H J LOWERY SUBSYS LEAD: B. ROBB

BREAKDOWN HIERARCHY:

- 1) DPS
- 2) MULTIFUNCTIONAL CRT DISPLAY SYSTEM (MCDS)
- 3) DISPLAY UNIT
- 4) CATHODE-RAY TUBE
- 5)
- 6)
- 7)
- 8)
- 9)

CRITICALITIES

FLIGHT PHASE	HDW/FUNC	ABORT	HDW/FUNC
PRELAUNCH:	3/2R	RTLS:	3/1R
LIFTOFF:	3/1R	TAL:	3/1R
ONORBIT:	3/1R	AOA:	3/1R
DEORBIT:	3/1R	ATO:	3/1R
LANDING/SAFEING:	3/1R		

REDUNDANCY SCREENS: A [ 1 ] B [ P ] C [ P ]

LOCATION: UPPER CREW AREA  
PART NUMBER:

CAUSES: SHOCK/ TEMPERATURE STRESS/ MECHANICAL FRACTURE/  
VIBRATION/ CONTAMINATION/ DEBRIS

EFFECTS/RATIONALE:

LOSS OF MONITORING CAPABILITY. REDUNDANT HARDWARE WOULD NOT BE  
ACCESSIBLE DURING PERIODS OF ANTICIPATED HIGH  
ACCELERATION/DEACCELERATION FORCES.

ie. 1. LIFT-OFF THROUGH MAIN ENGINE CUT-OFF - APPROXIMATELY 8 MIN  
40 SEC; 2. ENTRY THROUGH SAFEING -APPROXIMATELY 400,000ft (TD -40  
MIN) THROUGH SAFEING.

REFERENCES:

INDEPENDENT ORBITER ASSESSMENT  
ORBITER SUBSYSTEM ANALYSIS WORKSHEET

DATE: 10/03/86 HIGHEST CRITICALITY HDW/FUNC  
SUBSYSTEM: DPS FLIGHT: 3/1R  
MDAC ID: 304 ABORT: 3/1R

ITEM: HI AND LOW VOLTAGE POWER SUPPLIES  
FAILURE MODE: NO OUTPUT/ERRONEOUS/ERRATIC OUTPUT

LEAD ANALYST: H J LOWERY SUBSYS LEAD: B. ROBB

BREAKDOWN HIERARCHY:

- 1) DPS
- 2) MULTIFUNCTIONAL CRT DISPLAY SYSTEM (MCDS)
- 3) DISPLAY UNIT
- 4) HIGH AND LOW (+/-5, 15, 28 & 80 VDC) VOLTAGE POWER SUPPLIES
- 5)
- 6)
- 7)
- 8)
- 9)

CRITICALITIES

FLIGHT PHASE	HDW/FUNC	ABORT	HDW/FUNC
PRELAUNCH:	3/2R	RTLS:	3/1R
LIFTOFF:	3/1R	TAL:	3/1R
ONORBIT:	3/1R	AOA:	3/1R
DEORBIT:	3/1R	ATO:	3/1R
LANDING/SAFEING:	3/1R		

REDUNDANCY SCREENS: A [ 1 ] B [ P ] C [ P ]

LOCATION: UPPER CREW AREA  
PART NUMBER:

CAUSES: MECHANICAL FRACTURES/ CONTAMINATION/ DEBRIS

EFFECTS/RATIONALE:

LOSS OF MONITORING CAPABILITY. REDUNDANT HARDWARE WOULD NOT BE ACCESSIBLE DURING PERIODS OF ANTICIPATED HIGH ACCELERATION/DEACCELERATION FORCES.

ie. 1. LIFT-OFF THROUGH MAIN ENGINE CUT-OFF - APPROXIMATELY 8 MIN 40 SEC; 2. ENTRY THROUGH SAFEING -APPROXIMATELY 400,000ft (TD -40 MIN) THROUGH SAFEING.

REFERENCES:

INDEPENDENT ORBITER ASSESSMENT  
ORBITER SUBSYSTEM ANALYSIS WORKSHEET

DATE: 10/03/86 HIGHEST CRITICALITY HDW/FUNC  
SUBSYSTEM: DPS FLIGHT: 3/1R  
MDAC ID: 305 ABORT: 3/1R

ITEM: RPC  
FAILURE MODE: OPEN/CLOSED/PREMATURE OPERATION

LEAD ANALYST: H J LOWERY SUBSYS LEAD: B. ROBB

BREAKDOWN HIERARCHY:

- 1) DPS
- 2) MULTIFUNCTIONAL CRT DISPLAY SYSTEM (MCDS)
- 3) DISPLAY UNIT
- 4) RPC
- 5)
- 6)
- 7)
- 8)
- 9)

CRITICALITIES

FLIGHT PHASE	HDW/FUNC	ABORT	HDW/FUNC
PRELAUNCH:	3/2R	RTLS:	3/1R
LIFTOFF:	3/1R	TAL:	3/1R
ONORBIT:	3/1R	AOA:	3/1R
DEORBIT:	3/1R	ATO:	3/1R
LANDING/SAFEING:	3/1R		

REDUNDANCY SCREENS: A [ 1 ] B [ P ] C [ P ]

LOCATION: UPPER CREA AREA  
PART NUMBER:

CAUSES: MECHANICAL FRACTURE/ CONTAMINATION/ DEBRIS

EFFECTS/RATIONALE:

LOSS OF MONITORING CAPABILITY. REDUNDANT HARDWARE WOULD NOT BE ACCESSIBLE DURING PERIODS OF ANTICIPATED HIGH ACCELERATION/DEACCELERATION FORCES.

ie. 1. LIFT-OFF THROUGH MAIN ENGINE CUT-OFF - APPROXIMATELY 8 MIN 40 SEC; 2. ENTRY THROUGH SAFEING -APPROXIMATELY 400,000ft (TD -40 MIN) THROUGH SAFEING.

REFERENCES:

INDEPENDENT ORBITER ASSESSMENT  
ORBITER SUBSYSTEM ANALYSIS WORKSHEET

DATE: 10/03/86 HIGHEST CRITICALITY HDW/FUNC  
SUBSYSTEM: DPS FLIGHT: 3/1R  
MDAC ID: 306 ABORT: 3/1R

ITEM: MEMORY  
FAILURE MODE: NO OUTPUT/ERRONEOUS/ERRATIC OUTPUT

LEAD ANALYST: H J LOWERY SUBSYS LEAD: B. ROBB

BREAKDOWN HIERARCHY:

- 1) DPS
- 2) MULTIFUNCTIONAL CRT DISPLAY SYSTEM (MCDS)
- 3) DEU
- 4) MEMORY
- 5)
- 6)
- 7)
- 8)
- 9)

CRITICALITIES			
FLIGHT PHASE	HDW/FUNC	ABORT	HDW/FUNC
PRELAUNCH:	3/2R	RTLS:	3/1R
LIFTOFF:	3/1R	TAL:	3/1R
ONORBIT:	3/1R	AOA:	3/1R
DEORBIT:	3/1R	ATO:	3/1R
LANDING/SAFEING:	3/1R		

REDUNDANCY SCREENS: A [ 1 ] B [ P ] C [ P ]

LOCATION: UPPER CREW AREA  
PART NUMBER:

CAUSES: CONTAMINATION/ DEBRIS

EFFECTS/RATIONALE:

LOSS OF MONITORING CAPABILITY. REDUNDANT HARDWARE WOULD NOT BE ACCESSIBLE DURING PERIODS OF ANTICIPATED HIGH ACCELERATION/DEACCELERATION FORCES.

ie. 1. LIFT-OFF THROUGH MAIN ENGINE CUT-OFF - APPROXIMATELY 8 MIN 40 SEC; 2. ENTRY THROUGH SAFEING -APPROXIMATELY 400,000ft (TD -40 MIN) THROUGH SAFEING.

REFERENCES:

INDEPENDENT ORBITER ASSESSMENT  
ORBITER SUBSYSTEM ANALYSIS WORKSHEET

DATE: 10/03/86 HIGHEST CRITICALITY HDW/FUNC  
SUBSYSTEM: DPS FLIGHT: 3/1R  
MDAC ID: 307 ABORT: 3/1R

ITEM: KEYBOARD ADAPTER  
FAILURE MODE: NO OUTPUT/ERRONEOUS/ERRATIC OUTPUT

LEAD ANALYST: H J LOWERY SUBSYS LEAD: B. ROBB

BREAKDOWN HIERARCHY:

- 1) DPS
- 2) MULTIFUNCTIONAL CRT DISPLAY SYSTEM (MCDS)
- 3) DEU
- 4) KEYBOARD ADAPTER
- 5)
- 6)
- 7)
- 8)
- 9)

FLIGHT PHASE	CRITICALITIES		
	HDW/FUNC	ABORT	HDW/FUNC
PRELAUNCH:	3/2R	RTLS:	3/1R
LIFTOFF:	3/1R	TAL:	3/1R
ONORBIT:	3/1R	AOA:	3/1R
DEORBIT:	3/1R	ATO:	3/1R
LANDING/SAFEING:	3/1R		

REDUNDANCY SCREENS: A [ 1 ] B [ P ] C [ P ]

LOCATION: UPPER CREW AREA  
PART NUMBER:

CAUSES: CONTAMINATION/ DEBRIS

EFFECTS/RATIONALE:

LOSS OF INPUTTING COMMAND CAPABILITY. REDUNDANT HARDWARE WOULD NOT BE ACCESSIBLE DURING PERIODS OF ANTICIPATED HIGH ACCELERATION/DEACCELERATION FORCES.

ie. 1. LIFT-OFF THROUGH MAIN ENGINE CUT-OFF - APPROXIMATELY 8 MIN 40 SEC; 2. ENTRY THROUGH SAFEING -APPROXIMATELY 400,000ft (TD -40 MIN) THROUGH SAFEING.

REFERENCES:



INDEPENDENT ORBITER ASSESSMENT  
ORBITER SUBSYSTEM ANALYSIS WORKSHEET

DATE: 10/03/86 HIGHEST CRITICALITY HDW/FUNC  
SUBSYSTEM: DPS FLIGHT: 3/1R  
MDAC ID: 308 ABORT: 3/1R

ITEM: SYMBOL GENERATOR  
FAILURE MODE: NO OUTPUT/ERRONEOUS/ERRATIC OUTPUT

LEAD ANALYST: H J LOWERY SUBSYS LEAD: B. ROBB

BREAKDOWN HIERARCHY:

- 1) DPS
- 2) MULTIFUNCTIONAL CRT DISPLAY SYSTEM (MCDS)
- 3) DEU
- 4) SYMBOL GENERATOR
- 5)
- 6)
- 7)
- 8)
- 9)

CRITICALITIES			
FLIGHT PHASE	HDW/FUNC	ABORT	HDW/FUNC
PRELAUNCH:	3/2R	RTLS:	3/1R
LIFTOFF:	3/1R	TAL:	3/1R
ONORBIT:	3/1R	AOA:	3/1R
DEORBIT:	3/1R	ATO:	3/1R
LANDING/SAFEING:	3/1R		

REDUNDANCY SCREENS: A [ 1 ] B [ P ] C [ P ]

LOCATION: UPPER CREW AREA  
PART NUMBER:

CAUSES: CONTAMINATION/ DEBRIS

EFFECTS/RATIONALE:

LOSS OF MONITORING CAPABILITY. REDUNDANT HARDWARE WOULD NOT BE ACCESSIBLE DURING PERIODS OF ANTICIPATED HIGH ACCELERATION/DEACCELERATION FORCES.

ie. 1. LIFT-OFF THROUGH MAIN ENGINE CUT-OFF - APPROXIMATELY 8 MIN 40 SEC; 2. ENTRY THROUGH SAFEING -APPROXIMATELY 400,000ft (TD -40 MIN) THROUGH SAFEING.

REFERENCES:

INDEPENDENT ORBITER ASSESSMENT  
ORBITER SUBSYSTEM ANALYSIS WORKSHEET

DATE: 10/03/86 HIGHEST CRITICALITY HDW/FUNC  
SUBSYSTEM: DPS FLIGHT: 3/1R  
MDAC ID: 309 ABORT: 3/1R

ITEM: MIA  
FAILURE MODE: NO OUTPUT/ERRONEOUS/ERRATIC OUTPUT

LEAD ANALYST: H J LOWERY SUBSYS LEAD: B. ROBB

BREAKDOWN HIERARCHY:

- 1) DPS
- 2) MULTIFUNCTIONAL CRT DISPLAY SYSTEM (MCDS)
- 3) DEU
- 4) MIA
- 5)
- 6)
- 7)
- 8)
- 9)

FLIGHT PHASE	CRITICALITIES		
	HDW/FUNC	ABORT	HDW/FUNC
PRELAUNCH:	3/2R	RTLS:	3/1R
LIFTOFF:	3/1R	TAL:	3/1R
ONORBIT:	3/1R	AOA:	3/1R
DEORBIT:	3/1R	ATO:	3/1R
LANDING/SAFEING:	3/1R		

REDUNDANCY SCREENS: A [ 1 ] B [ P ] C [ P ]

LOCATION: UPPER CREW AREA  
PART NUMBER:

CAUSES: CONTAMINATION/ DEBRIS

EFFECTS/RATIONALE:

LOSS OF MONITORING CAPABILITY. REDUNDANT HARDWARE WOULD NOT BE ACCESSIBLE DURING PERIODS OF ANTICIPATED HIGH ACCELERATION/DEACCELERATION FORCES.  
ie. 1. LIFT-OFF THROUGH MAIN ENGINE CUT-OFF - APPROXIMATELY 8 MIN 40 SEC; 2. ENTRY THROUGH SAFEING -APPROXIMATELY 400,000ft (TD -40 MIN) THROUGH SAFEING.

REFERENCES:

INDEPENDENT ORBITER ASSESSMENT  
ORBITER SUBSYSTEM ANALYSIS WORKSHEET

DATE: 10/03/86 HIGHEST CRITICALITY HDW/FUNC  
SUBSYSTEM: DPS FLIGHT: 3/1R  
MDAC ID: 310 ABORT: 3/1R

ITEM: CONTROL LOGIC  
FAILURE MODE: NO OUTPUT/ERRONEOUS/ERRATIC OUTPUT

LEAD ANALYST: H J LOWERY SUBSYS LEAD: B. ROBB

BREAKDOWN HIERARCHY:

- 1) DPS
- 2) MULTIFUNCTIONAL CRT DISPLAY SYSTEM (MCDS)
- 3) DEU
- 4) CONTROL LOGIC
- 5)
- 6)
- 7)
- 8)
- 9)

CRITICALITIES

FLIGHT PHASE	HDW/FUNC	ABORT	HDW/FUNC
PRELAUNCH:	3/2R	RTLS:	3/1R
LIFTOFF:	3/1R	TAL:	3/1R
ONORBIT:	3/1R	AOA:	3/1R
DEORBIT:	3/1R	ATO:	3/1R
LANDING/SAFEING:	3/1R		

REDUNDANCY SCREENS: A [ 1 ] B [ P ] C [ P ]

LOCATION: UPPER CREW AREA  
PART NUMBER:

CAUSES: CONTAMINATION/ DEBRIS

EFFECTS/RATIONALE:

LOSS OF MONITORING CAPABILITY. REDUNDANT HARDWARE WOULD NOT BE ACCESSIBLE DURING PERIODS OF ANTICIPATED HIGH ACCELERATION/DEACCELERATION FORCES.  
ie. 1. LIFT-OFF THROUGH MAIN ENGINE CUT-OFF - APPROXIMATELY 8 MIN 40 SEC; 2. ENTRY THROUGH SAFEING -APPROXIMATELY 400,000ft (TD -40 MIN) THROUGH SAFEING.

REFERENCES:

INDEPENDENT ORBITER ASSESSMENT  
ORBITER SUBSYSTEM ANALYSIS WORKSHEET

DATE: 10/03/86 HIGHEST CRITICALITY HDW/FUNC  
SUBSYSTEM: DPS FLIGHT: 3/1R  
MDAC ID: 311 ABORT: 3/1R

ITEM: POWER SUPPLIES  
FAILURE MODE: NO OUTPUT/ERRONEOUS/ERRATIC OUTPUT

LEAD ANALYST: H J LOWERY SUBSYS LEAD: B. ROBB

BREAKDOWN HIERARCHY:

- 1) DPS
- 2) MULTIFUNCTIONAL CRT DISPLAY SYSTEM (MCDS)
- 3) DEU
- 4) POWER SUPPLIES (+/-5, 12 & 15 VDC)
- 5)
- 6)
- 7)
- 8)
- 9)

CRITICALITIES

FLIGHT PHASE	HDW/FUNC	ABORT	HDW/FUNC
PRELAUNCH:	3/2R	RTLS:	3/1R
LIFTOFF:	3/1R	TAL:	3/1R
ONORBIT:	3/1R	AOA:	3/1R
DEORBIT:	3/1R	ATO:	3/1R
LANDING/SAFEING:	3/1R		

REDUNDANCY SCREENS: A [ 1 ] B [ P ] C [ P ]

LOCATION: UPPER CREW AREA  
PART NUMBER:

CAUSES: CONTAMINATION/ DEBRIS

EFFECTS/RATIONALE:

LOSS OF MONITORING CAPABILITY. REDUNDANT HARDWARE WOULD NOT BE ACCESSIBLE DURING PERIODS OF ANTICIPATED HIGH ACCELERATION/DEACCELERATION FORCES.

ie. 1. LIFT-OFF THROUGH MAIN ENGINE CUT-OFF - APPROXIMATELY 8 MIN 40 SEC; 2. ENTRY THROUGH SAFEING -APPROXIMATELY 400,000ft (TD -40 MIN) THROUGH SAFEING.

REFERENCES:

INDEPENDENT ORBITER ASSESSMENT  
ORBITER SUBSYSTEM ANALYSIS WORKSHEET

DATE: 10/03/86 HIGHEST CRITICALITY HDW/FUNC  
SUBSYSTEM: DPS FLIGHT: 3/1R  
MDAC ID: 312 ABORT: 3/1R

ITEM: RPC  
FAILURE MODE: OPEN/CLOSED/PREMATURE OPERATION

LEAD ANALYST: H J LOWERY SUBSYS LEAD: B. ROBB

BREAKDOWN HIERARCHY:

- 1) DPS
- 2) MULTIFUNCTIONAL CRT DISPLAY SYSTEM (MCDS)
- 3) DEU
- 4) RPC
- 5)
- 6)
- 7)
- 8)
- 9)

FLIGHT PHASE	CRITICALITIES		HDW/FUNC
	HDW/FUNC	ABORT	
PRELAUNCH:	3/2R	RTLS:	3/1R
LIFTOFF:	3/1R	TAL:	3/1R
ONORBIT:	3/1R	AOA:	3/1R
DEORBIT:	3/1R	ATO:	3/1R
LANDING/SAFEING:	3/1R		

REDUNDANCY SCREENS: A [ 1 ] B [ P ] C [ P ]

LOCATION: UPPER CREW AREA  
PART NUMBER:

CAUSES: TEMPERATURE STRESS/ MECHANICAL FRACTURE/ CONTAMINATION/  
DEBRIS

EFFECTS/RATIONALE:

LOSS OF MONITORING CAPABILITY. REDUNDANT HARDWARE WOULD NOT BE  
ACCESSIBLE DURING PERIODS OF ANTICIPATED HIGH  
ACCELERATION/DEACCELERATION FORCES.

ie. 1. LIFT-OFF THROUGH MAIN ENGINE CUT-OFF - APPROXIMATELY 8 MIN  
40 SEC; 2. ENTRY THROUGH SAFEING -APPROXIMATELY 400,000ft (TD -40  
MIN) THROUGH SAFEING.

REFERENCES:

INDEPENDENT ORBITER ASSESSMENT  
ORBITER SUBSYSTEM ANALYSIS WORKSHEET

DATE: 10/03/86 HIGHEST CRITICALITY HDW/FUNC  
SUBSYSTEM: DPS FLIGHT: 3/3  
MDAC ID: 313 ABORT: 3/3

ITEM: LOAD SWITCH  
FAILURE MODE: OPEN/CLOSED/PREMATURE OPERATION

LEAD ANALYST: H J LOWERY SUBSYS LEAD: B. ROBB

BREAKDOWN HIERARCHY:

- 1) DPS
- 2) MULTIFUNCTIONAL CRT DISPLAY SYSTEM (MCDS)
- 3) DEU
- 4) LOAD SWITCH
- 5)
- 6)
- 7)
- 8)
- 9)

CRITICALITIES

FLIGHT PHASE	HDW/FUNC	ABORT	HDW/FUNC
PRELAUNCH:	3/3	RTLS:	3/3
LIFTOFF:	3/3	TAL:	3/3
ONORBIT:	3/3	AOA:	3/3
DEORBIT:	3/3	ATO:	3/3
LANDING/SAFING:	3/3		

REDUNDANCY SCREENS: A [NA ] B [NA ] C [NA ]

LOCATION: UPPER CREW AREA  
PART NUMBER:

CAUSES: MECHANICAL FRACTURE/ CONTAMINATION/ DEBRIS

EFFECTS/RATIONALE:

DEUS ARE NOT NORMALLY RELOADED DURING A MISSION. SWITCH IS NOT NEEDED.

REFERENCES:

INDEPENDENT ORBITER ASSESSMENT  
ORBITER SUBSYSTEM ANALYSIS WORKSHEET

DATE: 10/03/86 HIGHEST CRITICALITY HDW/FUNC  
SUBSYSTEM: DPS FLIGHT: 3/1R  
MDAC ID: 314 ABORT: 3/1R

ITEM: FUNCTION SWITCH  
FAILURE MODE: OPEN/CLOSED/PREMATURE OPERATION

LEAD ANALYST: H J LOWERY SUBSYS LEAD: B. ROBB

BREAKDOWN HIERARCHY:

- 1) DPS
- 2) MULTIFUNCTIONAL CRT DISPLAY SYSTEM (MCDS)
- 3) DEU
- 4) FUNCTION SWITCH
- 5)
- 6)
- 7)
- 8)
- 9)

CRITICALITIES			
FLIGHT PHASE	HDW/FUNC	ABORT	HDW/FUNC
PRELAUNCH:	3/2R	RTLS:	3/1R
LIFTOFF:	3/1R	TAL:	3/1R
ONORBIT:	3/1R	AOA:	3/1R
DEORBIT:	3/1R	ATO:	3/1R
LANDING/SAFING:	3/1R		

REDUNDANCY SCREENS: A [ 1 ] B [ P ] C [ P ]

LOCATION: UPPER CREW AREA  
PART NUMBER:

CAUSES: MECHANICAL FRACTURE/ CONTAMINATION/ DEBRIS

EFFECTS/RATIONALE:  
IMPROPER MAJOR FUNCTION IDENTIFICATION

REFERENCES:

INDEPENDENT ORBITER ASSESSMENT  
ORBITER SUBSYSTEM ANALYSIS WORKSHEET

DATE: 10/03/86 HIGHEST CRITICALITY HDW/FUNC  
SUBSYSTEM: DPS FLIGHT: 3/1R  
MDAC ID: 315 ABORT: 3/1R

ITEM: DATA BUS COUPLER (DBC)  
FAILURE MODE: OPEN/SHORT

LEAD ANALYST: H J LOWERY SUBSYS LEAD: B. ROBB

BREAKDOWN HIERARCHY:

- 1) DPS
- 2) MULTIFUNCTIONAL CRT DISPLAY SYSTEM (MCDS)
- 3) DBC
- 4)
- 5)
- 6)
- 7)
- 8)
- 9)

CRITICALITIES

FLIGHT PHASE	HDW/FUNC	ABORT	HDW/FUNC
PRELAUNCH:	3/2R	RTLS:	3/1R
LIFTOFF:	3/1R	TAL:	3/1R
ONORBIT:	3/1R	AOA:	3/1R
DEORBIT:	3/1R	ATO:	3/1R
LANDING/SAFEING:	3/1R		

REDUNDANCY SCREENS: A [ 1 ] B [ P ] C [ P ]

LOCATION: ALL AV BAYS  
PART NUMBER:

CAUSES: MECHANICAL FRACTURE/ CONTAMINATION/ DEBRIS

EFFECTS/RATIONALE:

LOSS OF DATA BUS. REDUNDANT HARDWARE WOULD NOT BE ACCESSIBLE DURING PERIODS OF ANTICIPATED HIGH ACCELERATION/DEACCELERATION FORCES.

ie. 1. LIFT-OFF THROUGH MAIN ENGINE CUT-OFF - APPROXIMATELY 8 MIN 40 SEC; 2. ENTRY THROUGH SAFEING -APPROXIMATELY 400,000ft (TD -40 MIN) THROUGH SAFEING.

REFERENCES:



INDEPENDENT ORBITER ASSESSMENT  
ORBITER SUBSYSTEM ANALYSIS WORKSHEET

DATE: 10/03/86 HIGHEST CRITICALITY HDW/FUNC  
SUBSYSTEM: DPS FLIGHT: 3/2R  
MDAC ID: 316 ABORT: /NA

ITEM: DBIA  
FAILURE MODE: OPEN/SHORT/ERRONEOUS/ERRATIC OUTPUT

LEAD ANALYST: H J LOWERY SUBSYS LEAD: B. ROBB

BREAKDOWN HIERARCHY:

- 1) DPS
- 2) MULTIFUNCTIONAL CRT DISPLAY SYSTEM (MCDS)
- 3) DBIA
- 4)
- 5)
- 6)
- 7)
- 8)
- 9)

FLIGHT PHASE	CRITICALITIES		
	HDW/FUNC	ABORT	HDW/FUNC
PRELAUNCH:	3/2R	RTLS:	3/2R
LIFTOFF:	3/2R	TAL:	/NA
ONORBIT:	/NA	AOA:	/NA
DEORBIT:	/NA	ATO:	/NA
LANDING/SAFING:	/NA		

REDUNDANCY SCREENS: A [ 1 ] B [ NA ] C [ P ]

LOCATION: AV BAY 5  
PART NUMBER:

CAUSES: MECHANICAL FRACTURE/ CONTAMINATION/ DEBRIS

EFFECTS/RATIONALE:  
LOSS OF ONE COMMAND/DATA PATH

REFERENCES:

INDEPENDENT ORBITER ASSESSMENT  
ORBITER SUBSYSTEM ANALYSIS WORKSHEET

DATE: 10/27/86 HIGHEST CRITICALITY HDW/FUNC  
SUBSYSTEM: DPS FLIGHT: 3/3  
MDAC ID: 317 ABORT: 3/3

ITEM: RESISTOR  
FAILURE MODE: OPEN

LEAD ANALYST: H J LOWERY SUBSYS LEAD: B. ROBB

BREAKDOWN HIERARCHY:

- 1) EPD&C
- 2) DPS&C
- 3) MCDS
- 4) RESISTOR
- 5)
- 6)
- 7)
- 8)
- 9)

FLIGHT PHASE	CRITICALITIES		
	HDW/FUNC	ABORT	HDW/FUNC
PRELAUNCH:	3/3	RTLS:	3/3
LIFTOFF:	3/3	TAL:	3/3
ONORBIT:	3/3	AOA:	3/3
DEORBIT:	3/3	ATO:	3/3
LANDING/SAFING:	3/3		

REDUNDANCY SCREENS: A [NA ] B [NA ] C [NA ]

LOCATION:  
PART NUMBER:

CAUSES: THERMAL STRESS, CONTAMINATION

EFFECTS/RATIONALE:

NO EFFECT. POWER TO MCDS IS NEITHER AFFECTED NOR INTERRUPTED. RESISTOR PROVIDES SIGNAL THAT INDICATES THE MCDS (DEU/DU) POWER STATUS "ON" OR "STBY". THE MDM (OF4) WILL INTERPRET NO SIGNAL AS POWER "OFF" CONDITION.

REFERENCES:

INDEPENDENT ORBITER ASSESSMENT  
ORBITER SUBSYSTEM ANALYSIS WORKSHEET

DATE: 10/27/86 HIGHEST CRITICALITY HDW/FUNC  
SUBSYSTEM: DPS FLIGHT: 3/3  
MDAC ID: 318 ABORT: 3/3

ITEM: RPC  
FAILURE MODE: PREMATURE OPERATION

LEAD ANALYST: H J LOWERY SUBSYS LEAD: B. ROBB

BREAKDOWN HIERARCHY:

- 1) DPS
- 2) MCDS
- 3) DU
- 4) RPC
- 5)
- 6)
- 7)
- 8)
- 9)

FLIGHT PHASE	CRITICALITIES		HDW/FUNC
	HDW/FUNC	ABORT	
PRELAUNCH:	3/3	RTLS:	3/3
LIFTOFF:	3/3	TAL:	3/3
ONORBIT:	3/3	AOA:	3/3
DEORBIT:	3/3	ATO:	3/3
LANDING/SAFING:	3/3		

REDUNDANCY SCREENS: A [NA ] B [NA ] C [NA ]

LOCATION:  
PART NUMBER:

CAUSES: MECHANICAL FRACTURE/CONTAMINATION/DEBRIS

EFFECTS/RATIONALE:  
NONE. DU WILL HAVE POWER APPLIED PREMATURELY.

REFERENCES:

INDEPENDENT ORBITER ASSESSMENT  
ORBITER SUBSYSTEM ANALYSIS WORKSHEET

DATE: 10/03/86 HIGHEST CRITICALITY HDW/FUNC  
SUBSYSTEM: DPS FLIGHT: 3/3  
MDAC ID: 319 ABORT: 3/3

ITEM: SWITCH, CRT POWER  
FAILURE MODE: PREMATURE OPERATION

LEAD ANALYST: H J LOWERY SUBSYS LEAD: B. ROBB

BREAKDOWN HIERARCHY:

- 1) DPS
- 2) MULTIFUNCTIONAL CRT DISPLAY SYSTEM (MCDS)
- 3) DU
- 4) SWITCH, CRT POWER
- 5)
- 6)
- 7)
- 8)
- 9)

CRITICALITIES			
FLIGHT PHASE	HDW/FUNC	ABORT	HDW/FUNC
PRELAUNCH:	3/3	RTLS:	3/3
LIFTOFF:	3/3	TAL:	3/3
ONORBIT:	3/3	AOA:	3/3
DEORBIT:	3/3	ATO:	3/3
LANDING/SAFING:	3/3		

REDUNDANCY SCREENS: A [NA ] B [NA ] C [NA ]

LOCATION:  
PART NUMBER:

CAUSES: MECHANICAL FRACTURE, CONTAMINATION

EFFECTS/RATIONALE:  
NONE. DU WILL HAVE POWER APPLIED PREMATURELY.

REFERENCES:

INDEPENDENT ORBITER ASSESSMENT  
ORBITER SUBSYSTEM ANALYSIS WORKSHEET

DATE: 10/03/86 HIGHEST CRITICALITY HDW/FUNC  
SUBSYSTEM: DPS FLIGHT: 3/3  
MDAC ID: 320 ABORT: 3/3

ITEM: RPC  
FAILURE MODE: PREMATURE OPERATION

LEAD ANALYST: H J LOWERY SUBSYS LEAD: B. ROBB

BREAKDOWN HIERARCHY:

- 1) DPS
- 2) MULTIFUNCTIONAL CRT DISPLAY SYSTEM (MCDS)
- 3) DEU
- 4) CONTROLLER
- 5)
- 6)
- 7)
- 8)
- 9)

FLIGHT PHASE	CRITICALITIES		HDW/FUNC
	HDW/FUNC	ABORT	
PRELAUNCH:	3/3	RTLS:	3/3
LIFTOFF:	3/3	TAL:	3/3
ONORBIT:	3/3	AOA:	3/3
DEORBIT:	3/3	ATO:	3/3
LANDING/SAFING:	3/3		

REDUNDANCY SCREENS: A [NA ] B [NA ] C [NA ]

LOCATION:  
PART NUMBER:

CAUSES: TEMPERATURE STRESS/MECHANICAL  
FRACTURE/CONTAMINATION/DEBRIS

EFFECTS/RATIONALE:  
NONE. DEU WILL HAVE POWER APPLIED PREMATURELY.

REFERENCES:

INDEPENDENT ORBITER ASSESSMENT  
ORBITER SUBSYSTEM ANALYSIS WORKSHEET

DATE: 11/03/86 HIGHEST CRITICALITY HDW/FUNC  
SUBSYSTEM: DPS FLIGHT: 3/3  
MDAC ID: 321 ABORT: 3/3

ITEM: DIODE, SUPPRESSOR  
FAILURE MODE: FAILS SHORTED

LEAD ANALYST: H J LOWERY SUBSYS LEAD: B. ROBB

BREAKDOWN HIERARCHY:

- 1) DPS
- 2) MCDS
- 3) DEU
- 4) DIODE, SUPPRESSOR
- 5)
- 6)
- 7)
- 8)
- 9)

CRITICALITIES			
FLIGHT PHASE	HDW/FUNC	ABORT	HDW/FUNC
PRELAUNCH:	3/3	RTLS:	3/3
LIFTOFF:	3/3	TAL:	3/3
ONORBIT:	3/3	AOA:	3/3
DEORBIT:	3/3	ATO:	3/3
LANDING/SAFING:	3/3		

REDUNDANCY SCREENS: A [NA ] B [NA ] C [NA ]

LOCATION:  
PART NUMBER:

CAUSES: THERMAL STRESS, CONTAMINATION, DEBRIS

EFFECTS/RATIONALE:  
LACK OF SUPPRESSION OF DEU TO MDM REVERSE TRANSIENTS WOULD ENABLE  
PREMATURE "ON" INDICATION OF THE DEU.

REFERENCES: FMEA-05-6S-BDIO1-1. NASA JSC FMEA & CIL REVIEW  
COMMENTS.

INDEPENDENT ORBITER ASSESSMENT  
ORBITER SUBSYSTEM ANALYSIS WORKSHEET

DATE: 11/10/86 HIGHEST CRITICALITY HDW/FUNC  
SUBSYSTEM: DPS FLIGHT: 3/1R  
MDAC ID: 322 ABORT: 3/1R

ITEM: SWITCH, CRT POWER  
FAILURE MODE: SHORT TO GROUND

LEAD ANALYST: H J LOWERY SUBSYS LEAD: B. ROBB

BREAKDOWN HIERARCHY:

- 1) DPS
- 2) MCDS
- 3) DU
- 4) SWITCH, CRT POWER
- 5)
- 6)
- 7)
- 8)
- 9)

FLIGHT PHASE	CRITICALITIES	
	HDW/FUNC	ABORT
PRELAUNCH:	3/1R	RTLS: 3/1R
LIFTOFF:	3/1R	TAL: 3/1R
ONORBIT:	3/1R	AOA: 3/1R
DEORBIT:	3/1R	ATO: 3/1R
LANDING/SAFING:	3/1R	

REDUNDANCY SCREENS: A [ 1 ] B [ P ] C [ P ]

LOCATION:  
PART NUMBER:

CAUSES: MECHANICAL SHOCK, CONTAMINATION, DEBRIS

EFFECTS/RATIONALE:  
ACTIVATION OF ASSOCIATED OVERLOAD PROTECTIVE CIRCUITS. LOSS OF  
DU.

REFERENCES: FMEA 05-6Q-2201-3. NASA-JSC FMEA & CIL REVIEW  
COMMENTS, 9-11-86.

INDEPENDENT ORBITER ASSESSMENT  
ORBITER SUBSYSTEM ANALYSIS WORKSHEET

DATE: 10/03/86 HIGHEST CRITICALITY HDW/FUNC  
SUBSYSTEM: DPS FLIGHT: 3/2R  
MDAC ID: 400 ABORT: 3/2R

ITEM: Tape transport mechanism  
FAILURE MODE: Loss of Output

LEAD ANALYST: K. Pietz SUBSYS LEAD: B. Robb

BREAKDOWN HIERARCHY:

- 1) DPS
- 2) MASS MEMORY UNITS (MMU)
- 3) Tape transport mechanism
- 4)
- 5)
- 6)
- 7)
- 8)
- 9)

CRITICALITIES

FLIGHT PHASE	HDW/FUNC	ABORT	HDW/FUNC
PRELAUNCH:	3/2R	RTLS:	/NA
LIFTOFF:	3/2R	TAL:	3/2R
ONORBIT:	3/2R	AOA:	3/2R
DEORBIT:	/NA	ATO:	3/2R
LANDING/SAFING:	/NA		

REDUNDANCY SCREENS: A [ 2 ] B [ P ] C [ P ]

LOCATION: Av Bay 1,2  
PART NUMBER: MC 615-0005

CAUSES: Worn tape or foreign matter on tape, Motor failure (worn brushes, etc.), Worn heads, Failure of negator spring causing Tape slippage due to incorrect tension.

EFFECTS/RATIONALE:

If both MMUs fail, OPS 2 and 3 software cannot be loaded. However, OPS 3 can be uplinked or BFS engaged for entry.

REFERENCES:



INDEPENDENT ORBITER ASSESSMENT  
ORBITER SUBSYSTEM ANALYSIS WORKSHEET

DATE: 10/03/86 HIGHEST CRITICALITY HDW/FUNC  
SUBSYSTEM: DPS FLIGHT: 3/2R  
MDAC ID: 401 ABORT: 3/2R

ITEM: Tape transport mechanism  
FAILURE MODE: Erroneous Output

LEAD ANALYST: K. Pietz SUBSYS LEAD: B. Robb

BREAKDOWN HIERARCHY:

- 1) DPS
- 2) MASS MEMORY UNITS (MMU)
- 3) Tape transport mechanism
- 4)
- 5)
- 6)
- 7)
- 8)
- 9)

CRITICALITIES			
FLIGHT PHASE	HDW/FUNC	ABORT	HDW/FUNC
PRELAUNCH:	3/2R	RTLS:	/NA
LIFTOFF:	3/2R	TAL:	3/2R
ONORBIT:	3/2R	AOA:	3/2R
DEORBIT:	/NA	ATO:	3/2R
LANDING/SAFING:	/NA		

REDUNDANCY SCREENS: A [ 2 ] B [ P ] C [ P ]

LOCATION: Av Bay 1,2  
PART NUMBER: MC 615-0005

CAUSES: Worn tape or foreign matter on tape, Tape slippage due to incorrect tension.

EFFECTS/RATIONALE:

If both MMUs fail, OPS 2 and 3 software cannot be loaded. However, OPS 3 can be uplinked or BFS engaged for entry.

REFERENCES:

INDEPENDENT ORBITER ASSESSMENT  
ORBITER SUBSYSTEM ANALYSIS WORKSHEET

DATE: 10/03/86 HIGHEST CRITICALITY HDW/FUNC  
SUBSYSTEM: DPS FLIGHT: 3/2R  
MDAC ID: 402 ABORT: 3/2R

ITEM: Read electronics  
FAILURE MODE: Loss of Output

LEAD ANALYST: K. Pietz SUBSYS LEAD: B. Robb

BREAKDOWN HIERARCHY:

- 1) DPS
- 2) MASS MEMORY UNITS (MMU)
- 3) Read electronics
- 4)
- 5)
- 6)
- 7)
- 8)
- 9)

CRITICALITIES

FLIGHT PHASE	HDW/FUNC	ABORT	HDW/FUNC
PRELAUNCH:	3/2R	RTLS:	/NA
LIFTOFF:	3/2R	TAL:	3/2R
ONORBIT:	3/2R	AOA:	3/2R
DEORBIT:	/NA	ATO:	3/2R
LANDING/SAFING:	/NA		

REDUNDANCY SCREENS: A [ 2 ] B [ P ] C [ P ]

LOCATION: Av Bay 1,2  
PART NUMBER: MC 615-0005

CAUSES: Electrical failure

EFFECTS/RATIONALE:

If both MMUs fail, OPS 2 and 3 software cannot be loaded.  
However, OPS 3 can be uplinked or BFS engaged for entry.

REFERENCES:

INDEPENDENT ORBITER ASSESSMENT  
ORBITER SUBSYSTEM ANALYSIS WORKSHEET

DATE: 10/03/86 HIGHEST CRITICALITY HDW/FUNC  
SUBSYSTEM: DPS FLIGHT: 3/2R  
MDAC ID: 403 ABORT: 3/2R

ITEM: Read electronics  
FAILURE MODE: Erroneous Output

LEAD ANALYST: K. Pietz SUBSYS LEAD: B. Robb

BREAKDOWN HIERARCHY:

- 1) DPS
- 2) MASS MEMORY UNITS (MMU)
- 3) Read electronics
- 4)
- 5)
- 6)
- 7)
- 8)
- 9)

CRITICALITIES			
FLIGHT PHASE	HDW/FUNC	ABORT	HDW/FUNC
PRELAUNCH:	3/2R	RTLS:	/NA
LIFTOFF:	3/2R	TAL:	3/2R
ONORBIT:	3/2R	AOA:	3/2R
DEORBIT:	/NA	ATO:	3/2R
LANDING/SAFING:	/NA		

REDUNDANCY SCREENS: A [ 2 ] B [ P ] C [ P ]

LOCATION: Av Bay 1,2  
PART NUMBER: MC 615-0005

CAUSES: Electrical failure

EFFECTS/RATIONALE:

If both MMUs fail, OPS 2 and 3 software cannot be loaded.  
However, OPS 3 can be uplinked or BFS engaged for entry.

REFERENCES:

INDEPENDENT ORBITER ASSESSMENT  
ORBITER SUBSYSTEM ANALYSIS WORKSHEET

DATE: 10/03/86 HIGHEST CRITICALITY HDW/FUNC  
SUBSYSTEM: DPS FLIGHT: 3/2R  
MDAC ID: 404 ABORT: 3/2R

ITEM: MIA  
FAILURE MODE: Loss of Output

LEAD ANALYST: K. Pietz SUBSYS LEAD: B. Robb

BREAKDOWN HIERARCHY:

- 1) DPS
- 2) MASS MEMORY UNITS (MMU)
- 3) MIA
- 4)
- 5)
- 6)
- 7)
- 8)
- 9)

CRITICALITIES

FLIGHT PHASE	HDW/FUNC	ABORT	HDW/FUNC
PRELAUNCH:	3/2R	RTLS:	/NA
LIFTOFF:	3/2R	TAL:	3/2R
ONORBIT:	3/2R	AOA:	3/2R
DEORBIT:	/NA	ATO:	3/2R
LANDING/SAFING:	/NA		

REDUNDANCY SCREENS: A [ 1 ] B [ P ] C [ P ]

LOCATION: Av Bay 1,2  
PART NUMBER: MC 615-0005

CAUSES: Electrical failure

EFFECTS/RATIONALE:

If both MMUs fail, OPS 2 and 3 software cannot be loaded.  
However, OPS 3 can be uplinked or BFS engaged for entry.

REFERENCES:

INDEPENDENT ORBITER ASSESSMENT  
ORBITER SUBSYSTEM ANALYSIS WORKSHEET

DATE: 10/03/86 HIGHEST CRITICALITY HDW/FUNC  
SUBSYSTEM: DPS FLIGHT: 3/2R  
MDAC ID: 405 ABORT: 3/2R

ITEM: MIA  
FAILURE MODE: Erroneous Output

LEAD ANALYST: K. Pietz SUBSYS LEAD: B. Robb

BREAKDOWN HIERARCHY:

- 1) DPS
- 2) MASS MEMORY UNITS (MMU)
- 3) MIA
- 4)
- 5)
- 6)
- 7)
- 8)
- 9)

CRITICALITIES

FLIGHT PHASE	HDW/FUNC	ABORT	HDW/FUNC
PRELAUNCH:	3/2R	RTLS:	/NA
LIFTOFF:	3/2R	TAL:	3/2R
ONORBIT:	3/2R	AOA:	3/2R
DEORBIT:	/NA	ATO:	3/2R
LANDING/SAFING:	/NA		

REDUNDANCY SCREENS: A [ 1 ] B [ P ] C [ P ]

LOCATION: Av Bay 1,2  
PART NUMBER: MC 615-0005

CAUSES: Electrical failure

EFFECTS/RATIONALE:

If both MMUs fail, OPS 2 and 3 software cannot be loaded.  
However, OPS 3 can be uplinked or BFS engaged for entry.

REFERENCES:

INDEPENDENT ORBITER ASSESSMENT  
ORBITER SUBSYSTEM ANALYSIS WORKSHEET

DATE: 10/03/86 HIGHEST CRITICALITY HDW/FUNC  
SUBSYSTEM: DPS FLIGHT: 3/2R  
MDAC ID: 406 ABORT: 3/2R

ITEM: Write electronics  
FAILURE MODE: Loss of Output

LEAD ANALYST: K. Pietz SUBSYS LEAD: B. Robb

BREAKDOWN HIERARCHY:

- 1) DPS
- 2) MASS MEMORY UNITS (MMU)
- 3) Write electronics
- 4)
- 5)
- 6)
- 7)
- 8)
- 9)

CRITICALITIES

FLIGHT PHASE	HDW/FUNC	ABORT	HDW/FUNC
PRELAUNCH:	3/2R	RTLS:	/NA
LIFTOFF:	3/2R	TAL:	3/2R
ONORBIT:	3/2R	AOA:	3/2R
DEORBIT:	/NA	ATO:	3/2R
LANDING/SAFING:	/NA		

REDUNDANCY SCREENS: A [ 2 ] B [ P ] C [ P ]

LOCATION: Av Bay 1,2  
PART NUMBER: MC 615-0005

CAUSES: Electrical failure

EFFECTS/RATIONALE:

If the ability to write to MMUs were lost, the mission could be terminated early. No danger to crew or vehicle.

REFERENCES:

INDEPENDENT ORBITER ASSESSMENT  
ORBITER SUBSYSTEM ANALYSIS WORKSHEET

DATE: 10/03/86 HIGHEST CRITICALITY HDW/FUNC  
SUBSYSTEM: DPS FLIGHT: 3/2R  
MDAC ID: 407 ABORT: 3/2R

ITEM: RPC  
FAILURE MODE: Failed Open

LEAD ANALYST: K. Pietz SUBSYS LEAD: B. Robb

BREAKDOWN HIERARCHY:

- 1) DPS
- 2) MASS MEMORY UNITS (MMU)
- 3) Power supply
- 4) RPC
- 5)
- 6)
- 7)
- 8)
- 9)

FLIGHT PHASE	CRITICALITIES		HDW/FUNC
	HDW/FUNC	ABORT	
PRELAUNCH:	3/2R	RTLS:	/NA
LIFTOFF:	3/2R	TAL:	3/2R
ONORBIT:	3/2R	AOA:	3/2R
DEORBIT:	/NA	ATO:	3/2R
LANDING/SAFING:	/NA		

REDUNDANCY SCREENS: A [ 1 ] B [ P ] C [ P ]

LOCATION: Av Bay 1,2  
PART NUMBER: MC 615-0005

CAUSES: Broken contact

EFFECTS/RATIONALE:

If both MMUs fail, OPS 2 and 3 software cannot be loaded.  
However, OPS 3 can be uplinked or BFS engaged for entry.

REFERENCES:

INDEPENDENT ORBITER ASSESSMENT  
ORBITER SUBSYSTEM ANALYSIS WORKSHEET

DATE: 10/03/86 HIGHEST CRITICALITY HDW/FUNC  
SUBSYSTEM: DPS FLIGHT: 3/2R  
MDAC ID: 408 ABORT: 3/2R

ITEM: Switch  
FAILURE MODE: Failed Open

LEAD ANALYST: K. Pietz SUBSYS LEAD: B. Robb

BREAKDOWN HIERARCHY:

- 1) DPS
- 2) MASS MEMORY UNITS (MMU)
- 3) Power supply
- 4) Switch
- 5)
- 6)
- 7)
- 8)
- 9)

CRITICALITIES

FLIGHT PHASE	HDW/FUNC	ABORT	HDW/FUNC
PRELAUNCH:	3/2R	RTLS:	/NA
LIFTOFF:	3/2R	TAL:	3/2R
ONORBIT:	3/2R	AOA:	3/2R
DEORBIT:	/NA	ATO:	3/2R
LANDING/SAFING:	/NA		

REDUNDANCY SCREENS: A [ 1 ] B [ P ] C [ P ]

LOCATION: Av Bay 1,2  
PART NUMBER: MC 615-0005

CAUSES: Broken contact

EFFECTS/RATIONALE:

If both MMUs fail, OPS 2 and 3 software cannot be loaded.  
However, OPS 3 can be uplinked or BFS engaged for entry.

REFERENCES:



INDEPENDENT ORBITER ASSESSMENT  
ORBITER SUBSYSTEM ANALYSIS WORKSHEET

DATE: 10/03/86 HIGHEST CRITICALITY HDW/FUNC  
SUBSYSTEM: DPS FLIGHT: 3/3  
MDAC ID: 409 ABORT: 3/3

ITEM: Switch  
FAILURE MODE: Failed Closed (on)

LEAD ANALYST: K. Pietz SUBSYS LEAD: B. Robb

BREAKDOWN HIERARCHY:

- 1) DPS
- 2) MASS MEMORY UNITS (MMU)
- 3) Power supply
- 4) Switch
- 5)
- 6)
- 7)
- 8)
- 9)

CRITICALITIES

FLIGHT PHASE	HDW/FUNC	ABORT	HDW/FUNC
PRELAUNCH:	3/2R	RTLS:	/NA
LIFTOFF:	3/3	TAL:	3/3
ONORBIT:	3/3	AOA:	3/3
DEORBIT:	/NA	ATO:	3/3
LANDING/SAFING:	/NA		

REDUNDANCY SCREENS: A [NA ] B [NA ] C [NA ]

LOCATION: Av Bay 1,2  
PART NUMBER: MC 615-0005

CAUSES: Stray particle

EFFECTS/RATIONALE:  
None

REFERENCES:

INDEPENDENT ORBITER ASSESSMENT  
ORBITER SUBSYSTEM ANALYSIS WORKSHEET

DATE: 10/03/86 HIGHEST CRITICALITY HDW/FUNC  
SUBSYSTEM: DPS FLIGHT: 3/2R  
MDAC ID: 410 ABORT: 3/2R

ITEM: Control logic  
FAILURE MODE: Loss of Output

LEAD ANALYST: K. Pietz SUBSYS LEAD: B. Robb

BREAKDOWN HIERARCHY:

- 1) DPS
- 2) MASS MEMORY UNITS (MMU)
- 3) Control logic
- 4)
- 5)
- 6)
- 7)
- 8)
- 9)

CRITICALITIES

FLIGHT PHASE	HDW/FUNC	ABORT	HDW/FUNC
PRELAUNCH:	3/2R	RTLS:	/NA
LIFTOFF:	3/2R	TAL:	3/2R
ONORBIT:	3/2R	AOA:	3/2R
DEORBIT:	/NA	ATO:	3/2R
LANDING/SAFING:	/NA		

REDUNDANCY SCREENS: A [ 2 ] B [ P ] C [ P ]

LOCATION: Av Bay 1,2  
PART NUMBER: MC 615-0005

CAUSES: Electrical failure

EFFECTS/RATIONALE:

If both MMUs fail, OPS 2 or 3 software cannot be loaded.  
However, OPS 3 can be uplinked or BFS engaged for entry.

REFERENCES:

INDEPENDENT ORBITER ASSESSMENT  
ORBITER SUBSYSTEM ANALYSIS WORKSHEET

DATE: 10/03/86 HIGHEST CRITICALITY HDW/FUNC  
SUBSYSTEM: DPS FLIGHT: 3/2R  
MDAC ID: 411 ABORT: 3/2R

ITEM: Control logic  
FAILURE MODE: Erroneous Output

LEAD ANALYST: K. Pietz SUBSYS LEAD: B. Robb

BREAKDOWN HIERARCHY:

- 1) DPS
- 2) MASS MEMORY UNITS (MMU)
- 3) Control logic
- 4)
- 5)
- 6)
- 7)
- 8)
- 9)

	CRITICALITIES		
FLIGHT PHASE	HDW/FUNC	ABORT	HDW/FUNC
PRELAUNCH:	3/2R	RTLS:	/NA
LIFTOFF:	3/2R	TAL:	3/2R
ONORBIT:	3/2R	AOA:	3/2R
DEORBIT:	/NA	ATO:	3/2R
LANDING/SAFING:	/NA		

REDUNDANCY SCREENS: A [ 2 ] B [ P ] C [ P ]

LOCATION: Av Bay 1,2  
PART NUMBER: MC 615-0005

CAUSES: Electrical failure

EFFECTS/RATIONALE:

If both MMUs fail, OPS 2 or 3 software cannot be loaded.  
However, OPS 3 can be uplinked or BFS engaged for entry.

REFERENCES:

INDEPENDENT ORBITER ASSESSMENT  
ORBITER SUBSYSTEM ANALYSIS WORKSHEET

DATE: 10/03/86 HIGHEST CRITICALITY HDW/FUNC  
SUBSYSTEM: DPS FLIGHT: 3/2R  
MDAC ID: 412 ABORT: 3/2R

ITEM: Power supply  
FAILURE MODE: Fails out of tolerance or Interrupt

LEAD ANALYST: K. Pietz SUBSYS LEAD: B. Robb

BREAKDOWN HIERARCHY:

- 1) DPS
- 2) MASS MEMORY UNITS (MMU)
- 3) Power supply
- 4)
- 5)
- 6)
- 7)
- 8)
- 9)

CRITICALITIES

FLIGHT PHASE	HDW/FUNC	ABORT	HDW/FUNC
PRELAUNCH:	3/2R	RTLS:	/NA
LIFTOFF:	3/2R	TAL:	3/2R
ONORBIT:	3/2R	AOA:	3/2R
DEORBIT:	/NA	ATO:	3/2R
LANDING/SAFING:	/NA		

REDUNDANCY SCREENS: A [ 2 ] B [ P ] C [ P ]

LOCATION: Av Bay 1,2  
PART NUMBER: MC 615-0005

CAUSES: Electrical failure

EFFECTS/RATIONALE:

If both MMUs fail, OPS 2 and 3 software cannot be loaded. However, OPS 3 can be uplinked or BFS engaged for entry. Neither of these options require the use of MMUs.

REFERENCES:

INDEPENDENT ORBITER ASSESSMENT  
ORBITER SUBSYSTEM ANALYSIS WORKSHEET

DATE: 10/20/86 HIGHEST CRITICALITY HDW/FUNC  
SUBSYSTEM: DPS FLIGHT: 3/2R  
MDAC ID: 413 ABORT: 3/2R

ITEM: RESISTOR, CURRENT LIMITER  
FAILURE MODE: FAILS OPEN

LEAD ANALYST: B. ROBB SUBSYS LEAD: B. ROBB

BREAKDOWN HIERARCHY:

- 1) DPS
- 2) MASS MEMORY UNIT (MMU)
- 3) POWER DISTRIBUTION
- 4) RESISTOR, CURRENT LIMITER
- 5)
- 6)
- 7)
- 8)
- 9)

CRITICALITIES			
FLIGHT PHASE	HDW/FUNC	ABORT	HDW/FUNC
PRELAUNCH:	3/2R	RTLS:	3/2R
LIFTOFF:	3/2R	TAL:	3/2R
ONORBIT:	3/2R	AOA:	3/2R
DEORBIT:	3/2R	ATO:	3/2R
LANDING/SAFING:	3/2R		

REDUNDANCY SCREENS: A [ 1 ] B [ P ] C [ P ]

LOCATION:  
PART NUMBER:

CAUSES: VIBRATION, SHOCK, PIECE PART FAILURE

EFFECTS/RATIONALE:  
LOSS CONTROL AND USE OF ONE MMU. LOAD GPC OR MCDS WITH REMAINING GOOD MMU.

REFERENCES:

INDEPENDENT ORBITER ASSESSMENT  
ORBITER SUBSYSTEM ANALYSIS WORKSHEET

DATE: 10/30/86 HIGHEST CRITICALITY HDW/FUNC  
SUBSYSTEM: DPS FLIGHT: 3/2R  
MDAC ID: 414 ABORT: 3/2R

ITEM: CONTROLLER, REMOTE POWER  
FAILURE MODE: LOSS OF OUTPUT

LEAD ANALYST: H J LOWERY SUBSYS LEAD: B. ROBB

BREAKDOWN HIERARCHY:

- 1) DPS
- 2) MMU
- 3) CONTROLLER, REMOTE POWER
- 4)
- 5)
- 6)
- 7)
- 8)
- 9)

CRITICALITIES			
FLIGHT PHASE	HDW/FUNC	ABORT	HDW/FUNC
PRELAUNCH:	3/2R	RTLS:	3/2R
LIFTOFF:	3/2R	TAL:	3/2R
ONORBIT:	3/2R	AOA:	3/2R
DEORBIT:	3/2R	ATO:	3/2R
LANDING/SAFING:	3/2R		

REDUNDANCY SCREENS: A [ 1 ] B [ P ] C [ P ]

LOCATION:  
PART NUMBER:

CAUSES: TEMPERATURE STRESS, MECHANICAL FRACTURE, CONTAMINATION,  
DEBRIS

EFFECTS/RATIONALE:  
NONE. BFS GPC AND A FROZEN PRIMARY GPC DO NOT REQUIRE IPL OR  
OVERLAY DURING ORBIT BEFORE ENTRY.

REFERENCES: FMEA NO. 05-6S-BRPC2-1. NASA-JSC FMEA CIL REVIEW  
COMMENTS.

INDEPENDENT ORBITER ASSESSMENT  
ORBITER SUBSYSTEM ANALYSIS WORKSHEET

DATE: 10/03/86 HIGHEST CRITICALITY HDW/FUNC  
SUBSYSTEM: DPS FLIGHT: 3/3  
MDAC ID: 415 ABORT: 3/3

ITEM: IPL Source Switch  
FAILURE MODE: Fails open

LEAD ANALYST: T. B. Cribbs SUBSYS LEAD: B. Robb

BREAKDOWN HIERARCHY:

- 1) DPS
- 2) General Purpose Computer (GPC)
- 3) Central Processing Unit (CPU)
- 4) MMU Initial Program Load (IPL) Source Switch
- 5)
- 6)
- 7)
- 8)
- 9)

CRITICALITIES

FLIGHT PHASE	HDW/FUNC	ABORT	HDW/FUNC
PRELAUNCH:	3/3	RTLS:	3/3
LIFTOFF:	3/3	TAL:	3/3
ONORBIT:	3/3	AOA:	3/3
DEORBIT:	3/3	ATO:	3/3
LANDING/SAFING:	3/3		

REDUNDANCY SCREENS: A [NA ] B [NA ] C [NA ]

LOCATION: Panel 06  
PART NUMBER:

CAUSES: IPL selector switch is shorted or power source is lost  
due to contamination

EFFECTS/RATIONALE:

IPL source switch is used at pre-launch to initialize GPC's. This failure could cause loss of a mission opportunity due to launch delay. During flight the GPC's are not typically re-IPL'ed, even though the MMU is used to retrieve new memory overlays (as opposed to the IPL loading the entire system software, including MCDS initialization).

REFERENCES: JSC 18820, JSC 11174, JSC 12770

INDEPENDENT ORBITER ASSESSMENT  
ORBITER SUBSYSTEM ANALYSIS WORKSHEET

DATE: 11/10/86 HIGHEST CRITICALITY HDW/FUNC  
SUBSYSTEM: DPS FLIGHT: 3/3  
MDAC ID: 416 ABORT: 3/3

ITEM: CONTROLLER, REMOTE POWER  
FAILURE MODE: PREMATURE OPERATION

LEAD ANALYST: T. B. Cribbs SUBSYS LEAD: B. Robb

BREAKDOWN HIERARCHY:

- 1) DPS
- 2) MMU
- 3) CONTROLLER, REMOTE POWER
- 4)
- 5)
- 6)
- 7)
- 8)
- 9)

CRITICALITIES

FLIGHT PHASE	HDW/FUNC	ABORT	HDW/FUNC
PRELAUNCH:	3/3	RTLS:	3/3
LIFTOFF:	3/3	TAL:	3/3
ONORBIT:	3/3	AOA:	3/3
DEORBIT:	3/3	ATO:	3/3
LANDING/SAFING:	3/3		

REDUNDANCY SCREENS: A [NA ] B [NA ] C [NA ]

LOCATION:  
PART NUMBER:

CAUSES: MECHANICAL SHOCK, CONTAMINATION, DEBRIS

EFFECTS/RATIONALE:  
NO EFFECT. PREMATURE TURN ON.

REFERENCES: 05-6S-BRPC2-1. NASA-JSC FMEA & CIL REVIEW COMMENTS,  
9-19-86.



INDEPENDENT ORBITER ASSESSMENT  
ORBITER SUBSYSTEM ANALYSIS WORKSHEET

DATE: 11/10/86 HIGHEST CRITICALITY HDW/FUNC  
SUBSYSTEM: DPS FLIGHT: 3/2R  
MDAC ID: 417 ABORT: 3/2R

ITEM: SWITCH, IPL  
FAILURE MODE: SWITCH SHORT, BOTH IPL OUTPUTS ARE TRUE.

LEAD ANALYST: H J LOWERY SUBSYS LEAD: B. Robb

BREAKDOWN HIERARCHY:

- 1) DPS
- 2) MMU
- 3) SWITCH, IPL
- 4)
- 5)
- 6)
- 7)
- 8)
- 9)

CRITICALITIES

FLIGHT PHASE	HDW/FUNC	ABORT	HDW/FUNC
PRELAUNCH:	3/2R	RTLS:	3/2R
LIFTOFF:	3/2R	TAL:	3/2R
ONORBIT:	3/2R	AOA:	3/2R
DEORBIT:	3/2R	ATO:	3/2R
LANDING/SAFING:	3/2R		

REDUNDANCY SCREENS: A [ 1 ] B [ P ] C [ P ]

LOCATION:  
PART NUMBER:

CAUSES: MECHANICAL SHOCK, CONTAMINATION, DEBRIS

EFFECTS/RATIONALE:  
LOSS OF GPC IF IN HALT MODE.

REFERENCES: 05-5-B16-1-1. NASA-JSC FMEA & CIL REVIEW COMMENTS,  
9-19-86.

INDEPENDENT ORBITER ASSESSMENT  
ORBITER SUBSYSTEM ANALYSIS WORKSHEET

DATE: 10/03/86 HIGHEST CRITICALITY HDW/FUNC  
SUBSYSTEM: DPS FLIGHT: 3/1R  
MDAC ID: 501 ABORT: 3/1R

ITEM: CIA  
FAILURE MODE: LOSS OF OUTPUT TO MAIN ENGINE ON ONE CHANNEL

LEAD ANALYST: B. ROBB SUBSYS LEAD: B. ROBB

BREAKDOWN HIERARCHY:

- 1) DPS
- 2) ENGINE INTERFACE UNIT (EIU)
- 3) CONTROLLER INTERFACE ADAPTER
- 4)
- 5)
- 6)
- 7)
- 8)
- 9)

CRITICALITIES

FLIGHT PHASE	HDW/FUNC	ABORT	HDW/FUNC
PRELAUNCH:	3/2R	RTLS:	3/1R
LIFTOFF:	3/1R	TAL:	3/1R
ONORBIT:	/NA	AOA:	3/1R
DEORBIT:	/NA	ATO:	3/1R
LANDING/SAFING:	/NA		

REDUNDANCY SCREENS: A [ 1 ] B [ P ] C [ P ]

LOCATION: AV BAY 4,5,6  
PART NUMBER:

CAUSES: CONTROLLER INTERFACE ADAPTER FAILS

EFFECTS/RATIONALE:

LOSS OF THROTTLE COMMANDS, SHUTDOWN COMMANDS, LIMIT  
INHIBIT/ENABLE COMMANDS, GPC SHUTDOWN COMMANDS, AND MPS DUMP  
COMMANDS.  
LOSS OF ONE OF THREE COMMAND PATHS WILL BE VOTED INVALID. NO  
EFFECT ON ENGINE OPERATIONS.

REFERENCES:

INDEPENDENT ORBITER ASSESSMENT  
ORBITER SUBSYSTEM ANALYSIS WORKSHEET

DATE: 10/03/86 HIGHEST CRITICALITY HDW/FUNC  
SUBSYSTEM: DPS FLIGHT: 3/1R  
MDAC ID: 502 ABORT: 3/1R

ITEM: MIA  
FAILURE MODE: LOSS OF OUTPUT TO MAIN ENGINE ON ONE CHANNEL

LEAD ANALYST: B. ROBB SUBSYS LEAD: B. ROBB

BREAKDOWN HIERARCHY:

- 1) DPS
- 2) ENGINE INTERFACE UNIT (EIU)
- 3) MULTIPLEXER INTERFACE ADAPTER
- 4)
- 5)
- 6)
- 7)
- 8)
- 9)

FLIGHT PHASE	CRITICALITIES		
	HDW/FUNC	ABORT	HDW/FUNC
PRELAUNCH:	3/2R	RTLS:	3/1R
LIFTOFF:	3/1R	TAL:	3/1R
ONORBIT:	/NA	AOA:	3/1R
DEORBIT:	/NA	ATO:	3/1R
LANDING/SAFING:	/NA		

REDUNDANCY SCREENS: A [ 1 ] B [ P ] C [ P ]

LOCATION: AV BAY 4,5,6  
PART NUMBER:

CAUSES: MULTIPLEXER INTERFACE ADAPTER FAILS

EFFECTS/RATIONALE:

LOSS OF THROTTLE COMMANDS, SHUTDOWN COMMANDS, LIMIT  
INHIBIT/ENABLE COMMANDS, GPC SHUTDOWN COMMANDS, AND MPS DUMP  
COMMANDS.

LOSS OF ONE OF THREE COMMAND PATHS WILL BE VOTED INVALID. NO  
EFFECT ON ENGINE OPERATIONS.

REFERENCES:

INDEPENDENT ORBITER ASSESSMENT  
ORBITER SUBSYSTEM ANALYSIS WORKSHEET

DATE: 10/03/86 HIGHEST CRITICALITY HDW/FUNC  
SUBSYSTEM: DPS FLIGHT: 3/1R  
MDAC ID: 503 ABORT: 3/1R

ITEM: POWER CONTROL SWITCH  
FAILURE MODE: LOSS OF OUTPUT TO MAIN ENGINE ON ANY OF THREE  
COMMAND CHANNELS

LEAD ANALYST: B. ROBB SUBSYS LEAD: B. ROBB

BREAKDOWN HIERARCHY:

- 1) DPS
- 2) ENGINE INTERFACE UNIT (EIU)
- 3) POWER CONTROL SWITCH
- 4)
- 5)
- 6)
- 7)
- 8)
- 9)

CRITICALITIES

FLIGHT PHASE	HDW/FUNC	ABORT	HDW/FUNC
PRELAUNCH:	3/2R	RTLS:	3/1R
LIFTOFF:	3/1R	TAL:	3/1R
ONORBIT:	/NA	AOA:	3/1R
DEORBIT:	/NA	ATO:	3/1R
LANDING/SAFING:	/NA		

REDUNDANCY SCREENS: A [ 1 ] B [ P ] C [ P ]

LOCATION: AV BAY 4,5,6  
PART NUMBER:

CAUSES: EIU POWER CONTROL SWITCH FAILS OPEN

EFFECTS/RATIONALE:

LOSS OF ALL COMMANDS AND STATUS OF THE ENGINE FOR THIS FAILURE  
MODE

THE LOSS OF THE ENTIRE EIU WILL RESULT IN ENGINE SHUTDOWN BY CREW  
BY SWITCHING AC POWER TO THE ENGINE TO OFF POSITION.

REFERENCES:

INDEPENDENT ORBITER ASSESSMENT  
ORBITER SUBSYSTEM ANALYSIS WORKSHEET

DATE: 10/03/86 HIGHEST CRITICALITY HDW/FUNC  
SUBSYSTEM: DPS FLIGHT: 3/1R  
MDAC ID: 504 ABORT: 3/1R

ITEM: INTERNAL POWER SUPPLIES  
FAILURE MODE: LOSS OF OUTPUT TO MAIN ENGINE ON ANY OF THREE  
COMMAND CHANNELS

LEAD ANALYST: B. ROBB SUBSYS LEAD: B. ROBB

BREAKDOWN HIERARCHY:

- 1) DPS
- 2) ENGINE INTERFACE UNIT (EIU)
- 3) INTERNAL POWER SUPPLIES
- 4)
- 5)
- 6)
- 7)
- 8)
- 9)

CRITICALITIES			
FLIGHT PHASE	HDW/FUNC	ABORT	HDW/FUNC
PRELAUNCH:	3/2R	RTLS:	3/1R
LIFTOFF:	3/1R	TAL:	3/1R
ONORBIT:	/NA	AOA:	3/1R
DEORBIT:	/NA	ATO:	3/1R
LANDING/SAFING:	/NA		

REDUNDANCY SCREENS: A [ 1 ] B [ P ] C [ P ]

LOCATION: AV BAY 4,5,6  
PART NUMBER:

CAUSES: INTERNAL POWER SUPPLIES FAIL

EFFECTS/RATIONALE:

LOSS OF THROTTLE COMMANDS, SHUTDOWN COMMANDS, LIMIT  
INHIBIT/ENABLE COMMANDS, GPC SHUTDOWN COMMANDS, AND MPS DUMP  
COMMANDS.

THE LOSS OF THE ENTIRE EIU WILL RESULT IN ENGINE SHUTDOWN BY CREW  
BY SWITCHING AC POWER TO THE ENGINE TO OFF POSITION.

REFERENCES:

INDEPENDENT ORBITER ASSESSMENT  
ORBITER SUBSYSTEM ANALYSIS WORKSHEET

DATE: 10/03/86 HIGHEST CRITICALITY HDW/FUNC  
SUBSYSTEM: DPS FLIGHT: 3/1R  
MDAC ID: 505 ABORT: 3/1R

ITEM: CONTROLLER INTERFACE ADAPTER  
FAILURE MODE: LOSS OF OUTPUT TO ONE OR THREE GPC ON STATUS OF  
ENGINES.

LEAD ANALYST: B. ROBB SUBSYS LEAD: B. ROBB

BREAKDOWN HIERARCHY:

- 1) DPS
- 2) ENGINE INTERFACE UNIT (EIU)
- 3) CONTROLLER INTERFACE ADAPTER
- 4)
- 5)
- 6)
- 7)
- 8)
- 9)

FLIGHT PHASE	CRITICALITIES		HDW/FUNC
	HDW/FUNC	ABORT	
PRELAUNCH:	3/2R	RTLS:	3/1R
LIFTOFF:	3/1R	TAL:	3/1R
ONORBIT:	/NA	AOA:	3/1R
DEORBIT:	/NA	ATO:	3/1R
LANDING/SAFING:	/NA		

REDUNDANCY SCREENS: A [ 1 ] B [ P ] C [ P ]

LOCATION: AV BAY 4,5,6  
PART NUMBER:

CAUSES: CONTROLLER INTERFACE ADAPTER FAILURE

EFFECTS/RATIONALE:

NO MAIN ENGINE MONITORING BY ONE OR THREE OF FOUR GPCS. MCC CONFIRMS COMMAND PATH GOOD BY MONITORING 3-G THROTTLE CONTROL. IF ENGINE IS NOT OPERATING, THE PUSHBUTTON FOR THE ENGINE MUST BE USED TO INFORM GUIDANCE FOR PREVALVE CLOSURES. FLIGHT RULE 2-17 PRECLUDES RESTRINGING DURING POWERED ASCENT THROUGH MECO.

REFERENCES:

INDEPENDENT ORBITER ASSESSMENT  
ORBITER SUBSYSTEM ANALYSIS WORKSHEET

DATE: 10/03/86 HIGHEST CRITICALITY HDW/FUNC  
SUBSYSTEM: DPS FLIGHT: 3/3  
MDAC ID: 506 ABORT: 3/1R

ITEM: OIE  
FAILURE MODE: LOSS OF OUTPUT TO S-BAND, MAINTENANCE RECORDER, OR  
LPS T-0 UMBILICAL

LEAD ANALYST: B. ROBB SUBSYS LEAD: B. ROBB

BREAKDOWN HIERARCHY:

- 1) DPS
- 2) ENGINE INTERFACE UNIT (EIU)
- 3) OPERATIONAL INTERFACE ELEMENT
- 4)
- 5)
- 6)
- 7)
- 8)
- 9)

FLIGHT PHASE	CRITICALITIES		HDW/FUNC
	HDW/FUNC	ABORT	
PRELAUNCH:	3/2R	RTLS:	3/1R
LIFTOFF:	3/3	TAL:	3/1R
ONORBIT:	/NA	AOA:	3/1R
DEORBIT:	/NA	ATO:	3/1R
LANDING/SAFING:	/NA		

REDUNDANCY SCREENS: A [NA ] B [NA ] C [NA ]

LOCATION: AV BAY 4,5,6  
PART NUMBER:

CAUSES: OPERATIONAL INTERFACE ELEMENT FAILURE

EFFECTS/RATIONALE:  
NO FM DATA RECORDING, NO MCC STATUS MONITORING OF ENGINE EXCEPT  
IN DOWNLIST DATA FROM GPC.

REFERENCES:

INDEPENDENT ORBITER ASSESSMENT  
ORBITER SUBSYSTEM ANALYSIS WORKSHEET

DATE: 10/20/86 HIGHEST CRITICALITY HDW/FUNC  
 SUBSYSTEM: DPS FLIGHT: 2/1R  
 MDAC ID: 507 ABORT: 2/1R

ITEM: CIRCUIT, EIU POWER  
 FAILURE MODE: ALL CREDIBLE MODES, OPEN, SHORTS

LEAD ANALYST: B. ROBB SUBSYS LEAD: B. ROBB

BREAKDOWN HIERARCHY:

- 1) DPS
- 2) ENGINE INTERFACE UNIT (EIU)
- 3) POWER DISTRIBUTION
- 4) CIRCUIT, EIU POWER
- 5)
- 6)
- 7)
- 8)
- 9)

FLIGHT PHASE	CRITICALITIES		HDW/FUNC
	HDW/FUNC	ABORT	
PRELAUNCH:	3/3	RTLS:	2/1R
LIFTOFF:	2/1R	TAL:	2/1R
ONORBIT:	/	AOA:	2/1R
DEORBIT:	/	ATO:	2/1R
LANDING/SAFING:	/		

REDUNDANCY SCREENS: A [ 1 ] B [ F ] C [ P ]

LOCATION:  
 PART NUMBER:

CAUSES: PIECE PART FAILURE, SHOCK, VIBRATION

EFFECTS/RATIONALE:  
 THE LOSS OF ONE OF TWO REDUNDANT CIRCUITS WILL NOT EFFECT THE  
 EIU. THE LOSS OF BOTH CIRCUITS WILL CAUSE LOSS OF EIU TO MAIN  
 ENGINE INTERFACE. MAIN ENGINE WOULD HAVE TO BE MANUALLY SHUT  
 DOWN AT MECO.

REFERENCES:



INDEPENDENT ORBITER ASSESSMENT  
ORBITER SUBSYSTEM ANALYSIS WORKSHEET

DATE: 11/03/86 HIGHEST CRITICALITY HDW/FUNC  
SUBSYSTEM: DPS FLIGHT: 1/1  
MDAC ID: 508 ABORT: 1/1

ITEM: EIU  
FAILURE MODE: ERRONEOUS OUTPUT

LEAD ANALYST: H J LOWERY SUBSYS LEAD: B. ROBB

BREAKDOWN HIERARCHY:

- 1) DPS
- 2) EIU
- 3)
- 4)
- 5)
- 6)
- 7)
- 8)
- 9)

FLIGHT PHASE	CRITICALITIES		HDW/FUNC
	HDW/FUNC	ABORT	
PRELAUNCH:	1/1	RTLS:	1/1
LIFTOFF:	1/1	TAL:	1/1
ONORBIT:	/NA	AOA:	/NA
DEORBIT:	/NA	ATO:	/NA
LANDING/SAFING:	/NA		

REDUNDANCY SCREENS: A [ 1 ] B [ F ] C [ P ]

LOCATION:  
PART NUMBER:

CAUSES: THERMAL STRESS, CONTAMINATION, DEBRIS

EFFECTS/RATIONALE:

ERRONEOUS OUTPUT MAY CAUSE THE GPC'S TO THINK THAT THE ENGINE HAS SHUT DOWN OR THE ENGINE TO CHANGE ITS THROTTLE SETTING, EITHER OF WHICH COULD BE CATASTROPHIC.

REFERENCES: NASA-JSC FMEA & CIL REVIEW COMMENTS.

INDEPENDENT ORBITER ASSESSMENT  
ORBITER SUBSYSTEM ANALYSIS WORKSHEET

DATE:	11/03/86	HIGHEST CRITICALITY	HDW/FUNC
SUBSYSTEM:	DPS	FLIGHT:	1/1
MDAC ID:	509	ABORT:	1/1

ITEM: SWITCH, POWER  
FAILURE MODE: SHORT BOTH CONTACTS TO GROUND

LEAD ANALYST: H J LOWERY                      SUBSYS LEAD: B. ROBB

BREAKDOWN HIERARCHY:

- 1) DPS
- 2) EIU
- 3) SWITCH, POWER
- 4)
- 5)
- 6)
- 7)
- 8)
- 9)

CRITICALITIES

FLIGHT PHASE	HDW/FUNC	ABORT	HDW/FUNC
PRELAUNCH:	1/1	RTLS:	1/1
LIFTOFF:	1/1	TAL:	1/1
ONORBIT:	/NA	AOA:	/NA
DEORBIT:	/NA	ATO:	/NA
LANDING/SAFING:	/NA		

REDUNDANCY SCREENS:    A [ 1 ]                      B [ F ]                      C [ P ]

LOCATION:  
PART NUMBER:

CAUSES: THERMAL STRESS, CONTAMINATION, DEBRIS

EFFECTS/RATIONALE:  
LOSS OF SWITCH CAUSES LOSS OF THAT EIU. LOSS OF EIU CAUSES LOSS OF COMMAND CAPABILITY TO THAT MAIN ENGINE. RESULTS COULD BE CATASTROPHIC.

REFERENCES: NASA-JSC FMEA & CIL REVIEW COMMENTS.

## APPENDIX F

### NASA FMEA TO IOA WORKSHEET CROSS REFERENCE/RECOMMENDATION

This section provides a cross reference between the NASA FMEA and corresponding IOA analysis worksheet(s) included in Appendix E. The Appendix F identifies: NASA FMEA Number, IOA Assessment Number, NASA criticality and redundancy screen data, and IOA recommendations.

#### Appendix F Legend

<u>Code</u>	<u>Definition</u>
-------------	-------------------

- |   |   |
|---|---|
| 1 | IOA recommends changing the second failure mode described in the effects field. |
| 2 | IOA recommends deleting the IOA failure mode.                                   |

APPENDIX F  
NASA FMEA TO IOA WORKSHEET CROSS REFERENCE / RECOMMENDATIONS

IDENTIFIERS		NASA		IOA RECOMMENDATIONS †			ISSUE
NASA FMEA NO:	IOA ASSESSMENT	CRIT HW/F	SCREEN A B C	CRIT HW/F	SCREEN A B C	OTHER (SEE LEGEND CODE)	
05-5 -B01-1-1	DPS-205	2 /1R	P P P			1	X
05-5 -B01-1-2	DPS-206	3 /1R	P P P				
05-5 -B02-1-1	DPS-201	2 /1R	P P P			1	X
05-5 -B02-1-2	DPS-202	3 /1R	P P P				
"	DPS-204	"	"				
05-5 -B02-1-3	DPS-225	2 /1R	P P P				
05-5 -B03-1-1	DPS-120	2 /1R	P P P	3 /1R	P P P	1	X
"	DPS-121	"	"	3 /1R	P P P	"	"
"	DPS-128	"	"	3 /1R	P P P	"	"
05-5 -B03-1-2	DPS-122	2 /1R	P P P				
"	DPS-123	"	"				
"	DPS-126	"	"				
"	DPS-127	"	"				
05-5 -B03-2-1	DPS-100	2 /1R	P P P	3 /1R	P P P	1	X
"	DPS-101	"	"	3 /1R	P P P	"	"
"	DPS-108	"	"	3 /1R	P P P	"	"
05-5 -B03-2-2	DPS-102	2 /1R	P P P				
"	DPS-103	"	"				
"	DPS-106	"	"				
"	DPS-107	"	"				
05-5 -B03-4-1	DPS-180	3 /2R	P N P				
"	DPS-181	"	"				
"	DPS-188	"	"				
05-5 -B03-4-2	DPS-182	3 /2R	P N P				
"	DPS-183	"	"				
"	DPS-186	"	"				
"	DPS-187	"	"				
05-5 -B03-5-1	DPS-140	2 /1R	P P P				
"	DPS-141	"	"				
"	DPS-148	"	"				
05-5 -B03-5-2	DPS-142	2 /1R	P P P				
"	DPS-143	"	"				
"	DPS-146	"	"				
"	DPS-147	"	"				
05-5 -B04-2-1	DPS-400	3 /2R	P P P				
"	DPS-401	"	"				
"	DPS-402	"	"				
"	DPS-403	"	"				
"	DPS-404	"	"				
"	DPS-405	"	"				
"	DPS-406	"	"				
"	DPS-407	"	"				
"	DPS-410	"	"				
"	DPS-412	"	"				
05-5 -B04-2-2	DPS-411	3 /2R	P P P				
05-5 -B08-1-1	DPS-501	2 /1R	P F P				

† IF DIFFERENT FROM NASA

APPENDIX F  
NASA FMEA TO IDA WORKSHEET CROSS REFERENCE / RECOMMENDATIONS

IDENTIFIERS		NASA		IDA RECOMMENDATIONS *			ISSUE
NASA FMEA NO:	IDA ASSESSMENT	CRIT HW/F	SCREEN A B C	CRIT HW/F	SCREEN A B C	OTHER (SEE LEGEND CODE)	
"	DPS-502	"	"				
"	DPS-503	"	"				
"	DPS-504	"	"				
"	DPS-505	"	"				
"	DPS-506	"	"				
05-5 -B13-1-4	DPS-316	3 /2R	P N P				
05-5 -B14-1-1	DPS-315	2 /1R	P P P				
05-5 -B15-1-1	DPS-231	3 /1R	P P P				
05-5 -B15-1-3	DPS-211	3 /1R	P P P				
05-5 -B16-1-1	DPS-220	3 /2R	P P P				
05-5 -B17-1-1	DPS-210	2 /1R	P P P				
05-5 -B18-1-1	DPS-221	3 /3	P P P				
05-5 -B18-1-2	DPS-222	3 /3	P P P				
05-5 -B19-1-1	DPS-223	3 /3	P P P				
05-5 -B19-1-2	DPS-224	3 /3	P P P				
05-5 -B20-1-1	DPS-415	2 /2	P P P				
05-5 -B21-1-1	DPS-301	3 /1R	P P P				
"	DPS-303	"	"				
05-5 -B21-1-2	DPS-302	3 /1R	P P P				
"	DPS-304	"	"				
05-5 -B22-1-1	DPS-300	2 /1R	P P P				
05-5 -B23-1-1	DPS-308A	3 /1R	P P P				
05-5 -B23-1-2	DPS-306	3 /1R	P P P				
"	DPS-307	"	"				
"	DPS-308	"	"				
"	DPS-309	"	"				
"	DPS-310	"	"				
"	DPS-311	"	"				
05-5 -B23-1-3	DPS-307A	2 /1R	P P P				
05-5 -B24-1-1	DPS-300B	2 /1R	P P P				
05-5 -B24-1-2	DPS-300A	3 /2R	P P P				
05-5 -B25-1-3	DPS-313	3 /1R	P P P				
05-5 -B26-1-1	DPS-314A	3 /1R	P P P				
05-5 -B26-1-2	DPS-314	3 /1R	P P P				
05-5 -B26-1-3	DPS-314B	3 /1R	P P P				
05-5 -B27-1-1	DPS-218	3 /3	P P P				
05-5 -B27-2-1	DPS-219	3 /3	P P P				
05-6S-BCKT1-1	DPS-507	2 /1R	P F P				
05-6S-BCKT2-1	DPS-316A	3 /3	P P P				
05-6S-BDIO1-1	DPS-312A	3 /1R	P P P				
05-6S-BDIO1-2	DPS-321	3 /3	N N N				
05-6S-BDIOX-1	DPS-230	3 /1R	P F P				
05-6S-BDMC1-1	DPS-215	3 /1R	P P P				
05-6S-BDMC1-2	DPS-214	3 /3	P P P				
05-6S-BFUS1-1	DPS-227	3 /1R	P P P				
05-6S-BFUS2-1	DPS-312C	3 /1R	P P P				

\* IF DIFFERENT FROM NASA

APPENDIX F  
NASA FMEA TO IOA WORKSHEET CROSS REFERENCE / RECOMMENDATIONS

IDENTIFIERS		NASA		IOA RECOMMENDATIONS *			ISSUE
NASA FMEA NO:	IOA ASSESSMENT	CRIT HW/F	SCREEN A B C	CRIT HW/F	SCREEN A B C	OTHER (SEE LEGEND CODE)	
05-65-BRES1-1	DPS-226	/NA	N N N				
05-65-BRES2-1	DPS-413	3 /2R	P P P				
05-65-BRES3-1	DPS-190	3 /1R	P F P				
05-65-BRES4-1	DPS-317	3 /3	P P P				
05-65-BRPC1-1	DPS-228	3 /1R	P P P				
05-65-BRPC1-2	DPS-229	3 /3	P P P				
05-65-BRPC2-1	DPS-414	3 /2R	P P P				
05-65-BRPC3-1	DPS-191	3 /1R	P F P				
05-65-BRPC3-2	DPS-192	3 /3	P N P				
05-65-BRPC4-1	DPS-305	3 /1R	P P P				
05-65-BRPC4-2	DPS-318	3 /3	P P P				
05-65-BRPC5-1	DPS-312	3 /1R	P P P				
05-65-BRPC5-2	DPS-320	3 /3	P P P				
05-65-BSW1 -1	DPS-232	3 /1R	P P P				
05-65-BSW1 -2	DPS-216	3 /3	P P P				
05-65-BSW1 -3	DPS-217	2 /1R	P P P				
05-65-BSW2 -1	DPS-408	3 /2R	P P P				
05-65-BSW2 -2	DPS-409	3 /3	P P P				
05-65-BSW3 -1	DPS-193	3 /1R	P F P				
05-65-BSW3 -2	DPS-194	3 /3	P N P				
05-65-BSW4 -1	DPS-312B	3 /1R	P P P				
05-65-BSW4 -2	DPS-319	3 /3	P P P				
05-65-BSW4 -3	DPS-322	3 /1R	P P P				
05-65-BSW5 -3	DPS-195	3 /1R	P F P				
EIU-1 (NEW)	DPS-508	1 /1	P F P				
EIU-2 (NEW)	DPS-509	1 /1	P F P				
MMU-1 (NEW)	DPS-416	3 /3	N N N				
MMU-2 (NEW)	DPS-417	3 /2R	P P P				
NONE	DPS-104	/				2	
NONE	DPS-105	/				2	
NONE	DPS-124	/				2	
NONE	DPS-125	/				2	
NONE	DPS-144	/				2	
NONE	DPS-145	/				2	
NONE	DPS-184	/				2	
NONE	DPS-185	/				2	
NONE	DPS-203	/				2	
NONE	DPS-207	/				2	
NONE	DPS-208	/				2	
NONE	DPS-209	/				2	
NONE	DPS-213	/				2	

\* IF DIFFERENT FROM NASA