

ROBOTICS BOOK - GENERIC

22 DEC 04

25 APR 05

Sheet 1 of 1

List of Implemented CR(s):

Multi_FileU334	RobGenU348	RobGenU352	RobGenU356
RobGenU345	RobGenU349	RobGenU353	RobGenU359
RobGenU346	RobGenU350	RobGenU354	RobGenU360
RobGenU347	RobGenU351	RobGenU355	

Incorporates the following:

1. Replace cover
2. Replace 39 thru 54, 57 thru 62, 73 and 74, 77 thru 104, 115 thru 120, 137 and 138, 155 and 156, 161 thru 198, 207 thru 240, 257 thru 274, 283 thru 290, 317 thru 320, 325 thru 328, 347 thru 350, 411 thru 414, 451 and 452.

APPROVED BY:

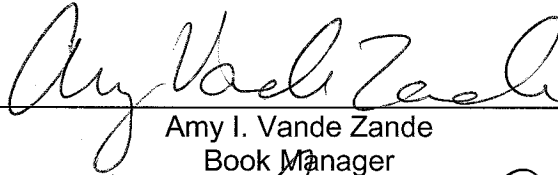

Amy I. Vande Zande
Book Manager

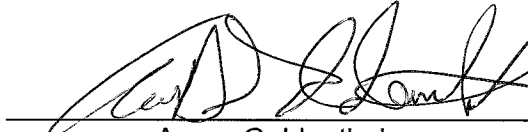

Aaron Goldenthal
Lead, Robotics Systems Group



Daniel D. Linder
Chief, Robotics Operations Branch



SODF Coordinator

ACCEPTED BY:



Michael T. Hurt
SODF Manager



International Space Station Robotics Group Robotics Book - Generic

All Expedition Flights

Mission Operations Directorate
Operations Division

25 APR 05

*These procedures are available
electronically on the SODF Homepage
at <http://mod.jsc.nasa.gov/do3>*

National Aeronautics and
Space Administration

Lyndon B. Johnson Space Center
Houston, Texas



6.311 MBS POA DIAGNOSTICS

(RBT GEN/X2R4 - ALL/FIN 4/SPN)

Page 1 of 1 page

I

PCS 1. SETUP
MSS: MBS:

√MBS Safing – Safed

Verify 'POA' Loaded – <blank>

2. DIAGNOSTICS
MSS: MBS: Diagnostic:

cmd 'Diagnostics' Test POA

<u>NOTE</u> The operator may cancel the current test by safing (SCR 19015).
--

MSS: MBS: Discrete Log:

Verify '**Diagnostic Test: MBS POA ... Test Passed**' (eleven) (SCR 30060).

If any tests fail, record which tests fail.

DCP SAFING → SAFE (Verify – ON) (SCR 21456, 23261)

PCS 3. CHECKPOINT DATA UPDATE
MSS: SSRMS: Checkpoint Data:

cmd Checkpoint Current Data (SCR 23238)

This Page Intentionally Blank

6.321 MBS POA CHECKOUT

(RBT GEN/E9 - ALL/FIN 3/SPN) Page 1 of 2 pages

I

1. POA SETUP FOR CAPTURE

PCS

MSS: MBS:

√MBS Safing – Not Safed

Verify 'POA' Loaded – blank

PCS

MSS: MBS: POA:

√POA Mechanisms – Calibrated

* If POA Mechanisms not calibrated

* | Perform {6.322 MBS POA CALIBRATION}, all (SODF: RBT
* | GEN: NOMINAL), then:

√Setup – Yes

* If Setup – No

* | Perform {6.323 POA SETUP FOR CAPTURE}, all
* | (SODF: RBT GEN: NOMINAL), then:

2. SLOW POA CHECKOUT

NOTE

POA commands will work only with SLOW speed (SCR 23242).

cmd Checkout ► Slow (Verify Speed – Slow) (SCR 23242)

Verify '**Confirm or Terminate**' prompt.

CAUTION

Due to end-to-end system latency, the RHC Trigger is hot up to 3 seconds prior to receiving a Trigger Hot icon status on the PCS.

NOTE

Once the trigger is hot, only safing or trigger commands should be sent to the Robotics equipment. If a configuration change is required, including routing MSS cameras, safe the system to exit POA operations (SCR 23262, 14662).

cmd Confirm (Verify RHC Trigger Hot Icon)

Verify POA Mode – Checkout POA

RHC

TRIGGER → press (momentarily)

6.321 MBS POA CHECKOUT

(RBT GEN/E9 - ALL/FIN 3/SPN) Page 2 of 2 pages

PCS	Verify 'Snare' Close	- blue (12 s max)
	Verify 'Carriage' Retract	- blue (90 s max)
	Verify 'Latch' Latch	- blue (65 s max)
	Verify 'Umbilical' Mate	- blue (10 s max)
	Verify 'Umbilical' Demate	- blue (10 s max)
	Verify 'Latch' Unlatch	- blue (65 s max)
	Verify 'Carriage' Derigidize	- blue (90 s max)
	Verify 'Snare' Open	- blue (12 s max)
	Verify 'Carriage' Extend	- blue (90 s max)

6.322 MBS POA CALIBRATION

(RBT GEN/X2R4 - ALL/FIN 2/SPN)

Page 1 of 1 page

I

NOTE

A Calibrate command may be aborted by a '**MBS POA LEU Mtr Velocity Runaway**' Robotics Advisory message and the MSS safed if one of the three POA mechanisms was initially located at the hardstop position. If safing occurs, cancel safing and restart this procedure from the beginning (SCR 20379).

PCS

MSS: MBS:

√MBS Safing – Not Safed

Verify 'POA' Loaded – blank

MSS: MBS: POA:

cmd 'POA Mechanisms' – Calibrate

Verify '**Confirm or Terminate**' prompt.

CAUTION

Due to end-to-end system latency, the RHC Trigger is hot up to 3 seconds prior to receiving a Trigger Hot Icon status on the PCS.

NOTE

Once the trigger is hot, only safing or trigger commands should be sent to the Robotics equipment. If a configuration change is required, including routing MSS cameras, safe the system to exit POA operations (SCR 23262, 14662).

cmd Confirm (Verify RHC Trigger Hot Icon)

NOTE

1. Apply safing to stop mechanism motion (SCR 23262, 14622).
2. Calibration might take up to 5 minutes 40 seconds to complete.

Verify POA Mode – Calibrate POA

RHC

TRIGGER → press (momentarily)

PCS

Verify 'Snare' Open – blue
Verify 'Carriage' Extend – blue
Verify 'Latch' Unlatch – blue
Verify POA Mechanisms – Calibrated
Verify Load Cell – Calibrated
Verify Motors – Inh (340 s max)

This Page Intentionally Blank

6.323 MBS POA SETUP FOR CAPTURE

(RBT GEN/E10 - ALL/FIN 4/SPN)

Page 1 of 1 page

I

PCS MSS: MBS

√MBS Safing – Not Safed

Verify POA Loaded – <blank>

PCS MSS: MBS: POA:

√POA Mechanisms – Calibrated

 * If POA Mechanisms not calibrated
 * | Perform {6.322 MBS POA CALIBRATION}, all (SODF:
 * | RBT: GEN: NOMINAL), then:

cmd Capture ► Setup ► Slow (Verify ‘Speed’ – Slow) (SCR 23242)

Verify ‘**Confirm or Terminate**’ prompt.

CAUTION
Due to end-to-end system latency, the RHC Trigger is hot up to 3 seconds prior to receiving a Trigger Hot Icon status on the PCS.

<u>NOTE</u>
Once the trigger is hot, only safing or trigger commands should be sent to the Robotics equipment. If a configuration change is required, including routing MSS cameras, safe the system to exit POA operations (SCR 23262, 14662).

cmd Confirm (Verify RHC Trigger Hot Icon)

Verify POA Mode – Setup for Capture

<u>NOTE</u>
Apply safing to stop mechanism motion (SCR 23262, 14662).

RHC TRIGGER → press (momentarily)

PCS

- Verify ‘Snare’ Open – blue
- Verify ‘Carriage’ Extend – blue
- Verify ‘Latch’ Unlatch – blue
- Verify ‘Motors’ – Inh (340 s max)

This Page Intentionally Blank

6.325 MBS POA AUTOMATIC RELEASE

(RBT GEN/E10 - ALL/FIN 4/SPN)

Page 1 of 3 pages

I

1. POA CALIBRATION STATUS VERIFICATION

PCS MSS: MBS:

√MBS Safing – Not Safed

PCS MSS: MBS: POA:

If POA Mechanisms not calibrated

Go to {8.212 POA MANUAL RELEASE WITH UNCALIBRATED POA}, all (SODF: RBT GEN: CORRECTIVE).

2. POA CARRIAGE RIGIDIZATION

MSS: MBS: POA:

If 'Latch' Latch – blue and 'Carriage' Tension < 4003 N

cmd Rigidize ► Slow (Verify Speed – Slow) (SCR 23242)

Verify '**Confirm or Terminate**' prompt.

NOTE

Once the trigger is hot, only safing or trigger commands should be sent to the Robotics equipment. If a configuration change is required, including routing MSS cameras, safe the system to exit POA operations (SCR 23262, 14662).

cmd Confirm (Verify RHC Trigger Hot icon)

Verify POA Mode – Rigidize

NOTE

Apply safing to stop mechanism motion (SCR 23262, 14662).

RHC TRIGGER → press (momentarily)

PCS Verify Tension > 4003 N (90 s max)

3. POA FILE CONFIGURATION

MSS: MBS:

√POA Payload – as required

6.325 MBS POA AUTOMATIC RELEASE

(RBT GEN/E10 - ALL/FIN 4/SPN)

Page 2 of 3 pages

4. SSRMS SETUP

Configure camera and overlays as required.

MSS: SSRMS:

√Loaded FOR – as required

Verify Loaded Parameters – √

√Display – as required

√Command – Internal>FOR

√Vernier

DCP BRAKES SSRMS → OFF (Verify OFF)

PCS Enter Mode – Manual (Verify blue)

5. INHIBIT STATION THRUSTERS

MSS: SSRMS: Thrusters:

cmd 'Desat Request' – Inhibit (Verify Inh)

6. SLOW RELEASE

MSS: MBS: POA:

cmd Release ► Automatic ► Slow (Verify Speed – Slow) (SCR 23242)

Verify '**Confirm or Terminate**' prompt.

CAUTION

Due to end-to-end system latency, the RHC Trigger is hot up to 3 seconds prior to receiving a Trigger Hot icon status on the PCS.

NOTE

Once the trigger is hot, only safing or trigger commands should be sent to the Robotics equipment. If a configuration change is required, including routing MSS cameras, safe the system to exit POA operations (SCR 23262, 14662).

cmd Confirm (Verify RHC Trigger Hot icon)

Verify POA Mode – Auto Release

RHC TRIGGER → press (momentarily)

6.325 MBS POA AUTOMATIC RELEASE

(RBT GEN/E10 - ALL/FIN 4/SPN)

Page 3 of 3 pages

PCS If POA was mated
 Verify 'Umbilical' Demate – blue (10 s max)

 If POA was latched
 Verify 'Latch' Unlatch – blue (65 s max)

 Verify 'Carriage' Derigidize – blue (90 s max)
 Verify 'Snare' Open – blue (12 s max)

THC Back off from POA until grapple fixture pin is clear.

PCS Verify 'Carriage' Extend – blue (90 s max)

7. ENABLE STATION THRUSTERS

MSS: SSRMS: Thrusters:

Thruster Controls for MSS Ops

cmd 'Desat Request' – Enable (Verify Ena)

This Page Intentionally Blank

6.327 MBS POA SEMI-MANUAL RELEASE

(RBT GEN/E10 - ALL/FIN 4/SPN)

Page 1 of 3 pages

I

1. [POA CALIBRATION STATUS VERIFICATION](#)

PCS MSS: MBS:

√MBS Safing – Not Safed

PCS MSS: MBS: POA:

If POA Mechanisms – Not Calibrated

Go to [{8.212 POA MANUAL RELEASE WITH UNCALIBRATED POA}](#), all (SODF: RBT GEN: CORRECTIVE).

2. [POA CARRIAGE RIGIDIZATION](#)

MSS: MBS: POA:

If 'Latch' Latch – blue and 'Carriage' Tension < 4003 N

cmd Rigidize ► Slow (Verify Speed – Slow) (SCR 23242)

Verify '**Confirm or Terminate**' prompt.

NOTE

Once the trigger is hot, only safing or trigger commands should be sent to the Robotics equipment. If a configuration change is required, including routing MSS cameras, safe the system to exit POA operations (SCR 23262, 14662).

cmd Confirm (Verify RHC Trigger Hot icon)

Verify POA Mode – Rigidize

NOTE

Apply safing to stop mechanism motion (SCR 23262, 14662).

RHC TRIGGER → press (momentarily)

PCS Verify Tension > 4003 N (90 s max)

3. [POA FILE CONFIGURATION](#)

MSS: MBS:

√POA Payload – as required

4. [SSRMS SETUP](#)

Configure camera and overlays, as required.

MSS: SSRMS:

6.327 MBS POA SEMI-MANUAL RELEASE

(RBT GEN/E10 - ALL/FIN 4/SPN)

Page 2 of 3 pages

√Loaded FOR – as required

Verify Loaded Parameters – √

√Display – as required

√Command – Internal>FOR

√Vernier

DCP BRAKES SSRMS → OFF (Verify OFF)

PCS Enter Mode – Manual (Verify blue)

5. INHIBITING STATION THRUSTERS

MSS: SSRMS: Thrusters:

cmd 'Desat Request' – Inhibit (Verify Inh)

6. SLOW RELEASE

MSS: MBS: POA:

PCS **cmd** Release ► Semi-Manual ► Slow (Verify Speed – Slow)
(SCR 23242)

Verify '**Confirm or Terminate**' prompt.

CAUTION

Due to end-to-end system latency, the RHC Trigger is hot up to 3 seconds prior to receiving a Trigger Hot icon status on the PCS.

NOTE

Once the trigger is hot, only safing or trigger commands should be sent to the Robotics equipment. If a configuration change is required, including routing MSS cameras, safe the system to exit POA operations (SCR 23262, 14662).

cmd Confirm (Verify RHC Trigger Hot icon)

Verify POA Mode – Semi-manual Release

NOTE

Apply safing to stop mechanism motion (SCR 23262, 14662).

RHC If 'Umbilical' Mate – blue
| TRIGGER → press (hold until 'Latch' Brakes – ON) (10 s max)
|
| Verify 'Umbilical' Demate – blue

6.327 MBS POA SEMI-MANUAL RELEASE

(RBT GEN/E10 - ALL/FIN 4/SPN)

Page 3 of 3 pages

PCS If 'Latch' Latch – blue
RHC | TRIGGER → press (hold until 'Latch' Brakes – On) (65 s max)
| Verify 'Latch' Unlatch – blue

TRIGGER → press (hold until 'Carriage' Brakes – On) (90 s max)

Verify 'Carriage' Derigidize – blue

TRIGGER → press (hold until 'Snare' Brakes – On) (12 s max)

Verify 'Snare' Open – blue

THC Back off from POA until grapple fixture pin is clear.

RHC TRIGGER → press (hold until 'Carriage' Brakes – On) (90 s max)

Verify 'Carriage' Extend – blue

7. ENABLING STATION THRUSTERS

PCS MSS: SSRMS: Thrusters: Thruster Controls for MSS Ops

cmd 'Desat Request' – Enable (Verify Ena)

This Page Intentionally Blank

6.332 MSS POWERUP FROM KEEP-ALIVE TO OPERATIONAL

(RBT GEN/X2R4 - ALL/FIN 2/SCR) Page 1 of 6 pages

I

1. ROBOTIC WORKSTATION CUP(LAB) POWERUP

Perform {6.114 LAB(CUP) RWS UOP BYPASS CABLE RECONFIGURATION}, step 2 (SODF: RBT GEN: NOMINAL), then:

NOTE

The Firmware Start, Start WHS, VGS 1, 2 and 3 and OCS fields will show stale data until a Frame Count is acquired at the end of step 1.2 (SCR 11448).

PCS

1.1 CEU Initialization

MSS: LAS5(LAP5) Initialize: LAS5(LAP5) Initialization

cmd 'B. CEU' Close (Verify – √)

Wait 60 seconds for POST to complete.

1.2 Comm Enable

NOTE

CEU-1/CEU-2 I/O will always be displayed as Enabled even when the CEU RT I/O is Inhibited. Use 'Frame Count' increments to verify I/O Enabled (SCR 16057).

cmd 'C. CB Ext 2(1) Bus comm' Enable

Verify 'Frame Count' increments.

Verify 'Firmware Start' – √

1.3 WHS Download

NOTE

The Set File and Set Address commands must be sent within 180 seconds of each other.

cmd 'D. Download WHS' Set File

cmd 'D. Download WHS' Set Address

Wait 1.5 minutes for download to complete.

1.4 WHS Startup

cmd 'E. Start WHS' Start (Verify – √)

* If Start not √
* | Wait 1 minute.
* |

* | **cmd** Start (Verify Start – √)

DCP

If PANEL/INST LIGHTING – OFF

PANEL/INST LIGHTING → Desired background light intensity

6.332 MSS POWERUP FROM KEEP-ALIVE TO OPERATIONAL

(RBT GEN/X2R4 - ALL/FIN 2/SCR) Page 2 of 6 pages

PCS 1.5 FDIR Enable
cmd 'F. FDIR' Enable (Verify – √)

1.6 VGS and OCS Download

NOTE

1. Download of VGS and OCS should take approximately 4 to 7.5 minutes to complete.
2. An '**R9Z - MSS CUP(LAB) OCS WHS Cmd Sequence Err**' Robotics Advisory message may be annunciated (SCR 19996).

cmd 'G. Set RWS location' – Cupola(Lab)

Verify VGS 1 – √
Verify VGS 2 – √
Verify VGS 3 – √
Verify OCS – √
Verify CEU Mode: Backup – √

DCP Verify RWS STATUS BACKUP –

MON 1,2,3 Verify monitor number appears and is flashing in upper left-hand corner.

PCS 1.7 First and Second CVIU Initialization
cmd 'H. Power CVIU4(12)' Close (Verify – √)
cmd 'I. Power CVIU5(2)' Close (Verify – √)

1.8 Third CVIU Initialization
If VTR or an orbiter video view is required
cmd 'J. Power CVIU6(3)' Close (Verify – √)

2. ACTIVE ROBOTIC WORKSTATION CUP(LAB) DESIGNATION

NOTE

Video overlay data from the Active RWS will not be available on a Backup RWS unless the Backup RWS is powered up before the other RWS is made Active. If two RWSs are to be used for MSS operations and video overlay data is to be shared, both RWSs must be in Backup before one is made Active.

PCS MSS: LAS5(LAP5) CEU Mode:

If alternate RWS is Active
cmd Active CEU – Backup (Verify alternate RWS is Backup)

cmd Cupola(Lab) – Active (Verify Cupola(Lab) – Active)

6.332 MSS POWERUP FROM KEEP-ALIVE TO OPERATIONAL

(RBT GEN/X2R4 - ALL/FIN 2/SCR) Page 3 of 6 pages

3. MBS POWERUP TO OPERATIONAL

NOTE

1. A warmup period in Keep-Alive will be required if the MBS has been unpowered for over 30 minutes. This is to ensure the MBS is within thermal limits.
2. The alternate MBS string must not be in Operational.
3. The operator can follow the transition to Operational by looking at the MSS Discrete Log.
4. The transition from Keep-Alive to Operational can be stopped at any time by issuing a Safing command.
5. If the alternate string is Off while the MBS is operational, expect the following Robotics Advisory messages:
 'R20 - MBS CRPCM ... Cat-2 Transmit Msg Err' (SCR 21744)
 'R20 - MBS CRPCM ... Cat-2 Receive Msg Err' (SCR 21744)
6. If the SSRMS is in Keep-Alive and is based off an MBS PDGF, expect the following Robotics Advisory message for each string that is in Keep-Alive:
 'R20 - MBS CRPCM ... Output Voltage ... Stat Err'

PCS

MSS: MBS: MCU:

cmd 'Prime'('Redundant') Operational (Verify Systems State – Operational) (~3 min)

4. SSRMS POWERUP TO OPERATIONAL

NOTE

A warmup period in Keep-Alive will be required if the SSRMS has been unpowered for over 30 minutes. This is to ensure that the SSRMS is within thermal limits.

4.1 Transition Prime(Redundant) String to Off

PCS

MSS: SSRMS: Power:

6.332 MSS POWERUP FROM KEEP-ALIVE TO OPERATIONAL

(RBT GEN/X2R4 - ALL/FIN 2/SCR) Page 4 of 6 pages

If SSRMS based on MBS PDGF and 'SSRMS' Prime(Redundant)
not Off

NOTE

1. It might take up to 30 seconds for the Off status indication to appear on the PCS.
2. Expect the '**R1E - MSS Active OCS SSRMS Prime(Redun) ACU SRT Comm Fail**' Robotics Advisory message (SCR 17730).
3. If the SSRMS is based on an MBS PDGF, expect the following Robotics Advisory message to go to Norm for the commanded SSRMS string that was in Keep-Alive:
'R2O - MBS CRPCM ... Output Voltage ... Stat Err'

cmd 'SSRMS' Prime(Redundant) – Off (Verify – Off)

4.2 Transition Prime(Redundant) String to Keep-Alive

If 'SSRMS' Prime(Redundant) – Off

NOTE

It might take up to 30 seconds for the Keep-Alive status indication to appear on PCS.

MSS: SSRMS: Power:

cmd 'SSRMS' Prime(Redundant) – Keep-Alive (Verify Keep-Alive)

4.3 Transition Redundant(Prime) String to Off

If 'SSRMS' Redundant(Prime) not Off

NOTE

1. It might take up to 30 seconds for the Off status indication to appear on the PCS.
2. Expect the '**R1E - MSS Active OCS SSRMS Prime(Redun) ACU SRT Comm Fail**' Robotics Advisory message (SCR 17730).
3. If the SSRMS is based on an MBS PDGF, expect the following Robotics Advisory message to go to Norm for the commanded SSRMS string that was in Keep-Alive:
'R2O - MBS CRPCM ... Output Voltage ... Stat Err'

MSS: SSRMS: Power:

cmd 'SSRMS' Redundant(Prime) – Off (Verify – Off)

6.332 MSS POWERUP FROM KEEP-ALIVE TO OPERATIONAL

(RBT GEN/X2R4 - ALL/FIN 2/SCR) Page 5 of 6 pages

4.4 Transition Prime(Redundant) String to Operational

NOTE

1. The transition from Keep-Alive to Operational can be stopped at any time by commanding SAFING on the DCP.
2. The operator can follow the transition to Operational by looking at the MSS discrete log.
3. If Tip LEE is mated to a PDGF connected to ISS Ground, expect '**R3L - SSRMS Pwr Flags Fail**' Robotics Advisory message (SCR 19019).
4. While the SSRMS transitions from Keep-Alive to Operational, the following 17 LEE inhibit errors will go to Norm approximately 10 seconds after they are raised:
'R9B - SSRMS LEE ... Inh Err'

cmd 'SSRMS' Prime(Redundant) – Operational

Verify 'Systems State' – Operational (~6 minutes)

5. MSS VIDEO COMPONENTS POWERUP

5.1 Video Distribution Units Powerup

PCS

MSS: MBS: VDU1:

sel [X] where [X] =

√'Primary', 'Redundant' Keep-Alive

Repeat

NOTE

1. Expect '**R6F - MBS... PFM Carrier On Video 1 Err**' Robotics Advisory message as each VDU is powered on. Message may toggle in and out of alarm until video is routed to the defined VDU (SCR 24376).
2. Robotics Advisory message '**R6E - MBS ... Baseband Sync Output Err**' may appear for one cycle as each VDU is powered on (SCR 30307).

sel '[X]' as required where [X] =

cmd '[X]' On (Verify – On)

Repeat

6.332 MSS POWERUP FROM KEEP-ALIVE TO OPERATIONAL

(RBT GEN/X2R4 - ALL/FIN 2/SCR) Page 6 of 6 pages

5.2 Cameras Powerup

MSS: MBS: MBS Central Camera icon:

sel [X] as required where [X] =

cmd 'Power' On (Verify – On)

Repeat

5.3 Lights Powerup

MSS: MBS: MBS Central Light icon:

sel [X] as required where [X] =

cmd [X] On (Verify – On)

Repeat

6.343 MBS POA POWERDOWN FROM OPERATIONAL TO KEEP-ALIVE ON I PRIME(REDUNDANT) STRING

(RBT GEN/E10 - ALL/FIN 2/SPN)

Page 1 of 1 page

PCS 1. SETUP
MSS: MBS:

√'MBS Safing' – Safed

2. TRANSITION MBS POA PRIME(REDUNDANT) STRING FROM OPERATIONAL TO KEEP-ALIVE

If the transition is interrupted by operator safing or by a system failure

√**MCC.**

MSS: MBS: POA Power:

cmd 'Prime'('Redundant') – Keep-Alive (Verify – Keep-Alive)
(30 s max)

MSS: Discrete Log:

Verify a '**Unit_Failed_On**' discrete message has not been annunciated (SCR 23231).

```
*****
* If 'Prime'('Redundant') – 'Unit_Failed_On' discrete message has been
* | annunciated
* |   cmd 'Prime'('Redundant') – Off (Verify – Off)
* |   cmd 'Prime'('Redundant') – Keep-Alive (Verify – Keep-Alive)
* |   (SCR 23231)
*****
```

3. TRANSITION MBS POA REDUNDANT(PRIME) STRING FROM OFF TO KEEP-ALIVE

MSS: MBS: MCU:

Verify 'Redundant'('Prime') – Keep-Alive

MSS: MBS: POA Power:

cmd 'Redundant'('Prime') – Keep-Alive (Verify – Keep-Alive)
(30 s max)

This Page Intentionally Blank

6.351 MBS MCAS LATCH CHECKOUT CLOSE

(RBT GEN/X2R4 - ALL/FIN 4/SPN) Page 1 of 3 pages

I

NOTE

1. Expect sporadic '**R4H - MBS MCU MCAS Latch Cat-2 Cksum Fail**' Robotics Advisory messages (SCR 22667).
2. A sporadic '**R4H - MBS MCU MCAS Abnormal Stop Cond**' Robotics Advisory message may be raised when a new IMCA initframe is loaded. This message may be ignored unless it is raised immediately following the end of the IMCA trajectory (SCR 28923).

1. POWER ON PRIME(REDUNDANT) MCAS LATCH IMCA

PCS

MSS: MBS: POA Power:

√'Prime' – Off (Keep-Alive)

√'Redundant' – Off (Keep-Alive)

MSS: MBS:

√'MBS Safing' – Not Safed

MSS: MBS: Latch:

Verify 'Active MBS IMCA' – None

Verify 'Power' – Off

MSS: MBS: Latch: Power:

cmd Enable (Verify – √)

cmd Confirm (Verify – √)

cmd On (Verify – √)

MSS: MBS: Latch:

Verify 'Active MBS IMCA' – MCAS Latch

Verify 'Mode' – Standby (6 seconds)

2. VERIFY POST TESTS

MSS: MBS: Latch: Commands ► BIT:

Verify all – blank

3. SETUP

Configure cameras and overlays as required.

6.351 MBS MCAS LATCH CHECKOUT CLOSE

(RBT GEN/X2R4 - ALL/FIN 4/SPN) Page 2 of 3 pages

4. [INITIALIZE MCAS LATCH IMCA WITH SAFING INITFRAME](#)

MSS: MBS: Latch:

Verify 'Latch' Closed – blank

Verify 'Latch' Open – ✓

MSS: MBS: Latch: Commands ► Checkout:

cmd Safing Initframe

MSS: MBS: Latch:

Verify 'Command Response' Initframe Received – ✓

Verify 'Command Response' Parameter Checksum Failed – blank

MSS: MBS: Latch: Commands ► Checkout:

Initframe Details:

Verify 'Limits' Position Change – High: 0 Rev

5. [MODE IMCA TO ON](#)

MSS: MBS: Latch: Commands ► Checkout:

cmd On

MSS: MBS: Latch:

Verify Mode – On

6. [CHECKOUT CLOSE](#)

MSS: MBS: Latch: Commands ► Checkout:

cmd Close

MSS: MBS: Latch:

Verify 'Command Response' Parameter Checksum Failed – blank

MSS: MBS: Latch: Commands ► Checkout:

Initframe Details:

Verify 'Limits' Position Change – High: 3110 Rev (± 2)

6.351 MBS MCAS LATCH CHECKOUT CLOSE

(RBT GEN/X2R4 - ALL/FIN 4/SPN) Page 3 of 3 pages

NOTE

1. For MSS: MBS: Latch: **MCAS Latch** 'Motor Status', expect large fluctuations in values for Acceleration and Current. The data is unreliable.
2. The Actuate command will initiate full opening of the MCAS Latch Mechanism.
3. To pause IMCA motion, mode IMCA back to On.

MSS: MBS: Latch: Commands ► Checkout:

MCAS Latch Checkout Commands

cmd Actuate

MSS: MBS: Latch: **MCAS Latch**

Verify 'Mode' – Enabled

Verify 'Motor Status' Position – incrementing

Verify 'Mode' – On (~7 minutes)

Verify 'Motor Status' Position: 3110 Rev (± 2)

Verify 'Latch' Closed – \surd

Verify 'Latch' Open – blank

7. MODE IMCA TO STANDBY

MSS: MBS: Latch: Commands ► Checkout:

MCAS Latch Checkout Commands

cmd Standby

MSS: MBS: Latch: **MCAS Latch**

Verify 'Mode' – Standby

8. POWER OFF PRIME(REDUNDANT) MCAS LATCH IMCA

MSS: MBS: LATCH: **MCAS Latch**

Verify 'Active MBS IMCA' – MCAS Latch

Verify 'Power' – On

Verify 'Mode' – Standby

MSS: MBS: Latch: Power: **MCAS Latch IMCA Power**

cmd Off (Verify Off – \surd)

MSS: MBS: Latch: **MCAS Latch**

Verify 'Active MBS IMCA' – None

Verify 'Power' – Off

This Page Intentionally Blank

NOTE

1. Expect sporadic '**R4H - MBS MCU MCAS Latch Cat-2 Cksum Fail**' Robotics Advisory messages (SCR 22667).
2. A sporadic '**R4H - MBS MCU MCAS Abnormal Stop Cond**' Robotics Advisory message may be raised when a new IMCA initframe is loaded. This message may be ignored unless it is raised immediately following the end of the IMCA trajectory (SCR 28923).

1. POWER ON PRIME(REDUNDANT) MCAS LATCH IMCA

PCS

MSS: MBS: POA Power:

- √'Prime' – Off (Keep-Alive)
- √'Redundant' – Off (Keep-Alive)

MSS: MBS:

- √'MBS Safing' – Not Safed

MSS: MBS: Latch:

Verify 'Active MBS IMCA' – None
Verify 'Power' – Off

MSS: MBS: Latch: Power:

- cmd** Enable (Verify – √)
- cmd** Confirm (Verify – √)
- cmd** On (Verify – √)

MSS: MBS: Latch:

Verify 'Active MBS IMCA' – MCAS Latch
Verify 'Power' – On
Verify 'Mode' – Standby (6 seconds)

2. VERIFY POST TESTS

MSS: MBS: Latch: Commands ► BIT:

Verify all – blank

3. SETUP

Configure cameras and overlays as required.

4. INITIALIZE MCAS LATCH IMCA WITH SAFING INITFRAME

MSS: MBS: Latch:

Verify 'Latch' Closed – √
Verify 'Latch' Open – blank

6.352 MBS MCAS LATCH CHECKOUT OPEN

(RBT GEN/X2R4 - ALL/FIN 3/SPN) Page 2 of 4 pages

MSS: MBS: Latch: Commands ► Checkout:

MCAS Latch Checkout Commands

cmd Safing Initframe

MSS: MBS: Latch: MCAS Latch

Verify 'Command Response' Initframe Received – ✓

Verify 'Command Response' Parameter Checksum Failed – blank

MSS: MBS: Latch: Commands ► Checkout: Initframe Details:

MBS IMCA Initframe Details

Verify 'Limits' 'Position Change – High': 0 Rev

5. MODE IMCA TO ON

MSS: MBS: Latch: Commands ► Checkout:

MCAS Latch Checkout Commands

cmd On

MSS: MBS: Latch: MCAS Latch

Verify 'Mode' – On

6. CHECKOUT OPEN

MSS: MBS: Latch: Commands ► Checkout:

MCAS Latch Checkout Commands

cmd Open

MSS: MBS: Latch: MCAS Latch

Verify 'Command Response' Parameter Checksum Failed – blank

MSS: MBS: Latch: Commands ► Checkout: Initframe Details:

MBS IMCA Initframe Details

Verify 'Limits' 'Position Change – High': -3110 Rev (± 2)

6.352 MBS MCAS LATCH CHECKOUT OPEN

(RBT GEN/X2R4 - ALL/FIN 3/SPN) Page 3 of 4 pages

NOTE

1. For MSS: MBS: Latch: **MCAS Latch** 'Motor Status', expect large fluctuations in values for Acceleration and Current. The data is unreliable.
2. The Actuate command will initiate full opening of the MCAS Latch Mechanism.
3. To pause IMCA motion, mode IMCA back to On.

MSS: MBS: Latch: Commands ► Checkout:

MCAS Latch Checkout Commands

cmd Actuate

MSS: MBS: Latch: **MCAS Latch**

Verify 'Mode' – Enabled

Verify 'Motor Status' Position – decrementing

Verify 'Mode' – On (~7 minutes)

Verify 'Motor Status' Position: -3110 Rev (± 2)

Verify 'Latch' Closed – blank

Verify 'Latch' Open – \checkmark

7. MODE IMCA TO STANDBY

MSS: MBS: Latch: Commands ► Checkout:

MCAS Latch Checkout Commands

cmd Standby

MSS: MBS: Latch: **MCAS Latch**

Verify 'Mode' – Standby

8. POWER OFF PRIME(REDUNDANT) MCAS LATCH IMCA

MSS: MBS: Latch: **MCAS Latch**

Verify 'Active MBS IMCA' – MCAS Latch

Verify 'Power' – On

Verify 'Mode' – Standby

MSS: MBS: Latch: Power: **MCAS Latch IMCA Power**

cmd Off (Verify Off – \checkmark)

MSS: MBS: Latch: **MCAS Latch**

6.352 MBS MCAS LATCH CHECKOUT OPEN

(RBT GEN/X2R4 - ALL/FIN 3/SPN) Page 4 of 4 pages

Verify 'Active MBS IMCA' – None
Verify 'Power' – Off

6.353 MBS MCAS LATCH CAPTURE

(RBT GEN/X2R4 - ALL/FIN 4/SPN) Page 1 of 5 pages

I

NOTE

1. Expect sporadic '**R4H - MBS MCU MCAS Latch Cat-2 Cksum Fail**' Robotics Advisory messages (SCR 22667).
2. A sporadic '**R4H - MBS MCU MCAS Abnormal Stop Cond**' Robotics Advisory message may be raised when a new IMCA initframe is loaded. This message may be ignored unless it is raised immediately following the end of the IMCA trajectory (SCR 28923).

1. POWER ON PRIME(REDUNDANT) MCAS LATCH IMCA

PCS

MSS: MBS: POA Power:

√'Prime' – Off (Keep-Alive)

√'Redundant' – Off (Keep-Alive)

MSS: MBS:

√'MBS Safing' – Not Safed

MSS: MBS: Latch:

Verify 'Active MBS IMCA' – None

Verify 'Power' – Off

MSS: MBS: Latch: Power:

cmd Enable (Verify – √)

cmd Confirm (Verify – √)

cmd On (Verify – √)

MSS: MBS: Latch:

Verify 'Active MBS IMCA' – MCAS Latch

Verify Mode – Standby (6 seconds)

2. VERIFY POST TESTS

MSS: MBS: Latch: Commands ► BIT:

Verify all – blank

3. SETUP

NOTE

At this point, the payload must be seated in the MCAS V-Guides and grappled by SSRMS.

Configure cameras and overlays as required.

6.353 MBS MCAS LATCH CAPTURE

(RBT GEN/X2R4 - ALL/FIN 4/SPN) Page 2 of 5 pages

Verify RTL 1 – √
Verify RTL 2 – √
Verify RTL 3 – √

4. INITIALIZE MCAS LATCH IMCA WITH SAFING INITFRAME

MSS: MBS: Latch:

Verify 'Latch' Closed – blank
Verify 'Latch' Open – √

MSS: MBS: Latch: Commands ► Close:

cmd Safing Initframe

MSS: MBS: Latch:

Verify 'Command Response' Initframe Received – √
Verify 'Command Response' Parameter Checksum Failed – blank

MSS: MBS: Latch: Commands ► Close:

Initframe Details:

Verify 'Limits' Position Change – High: 0 Rev

5. MODE IMCA TO ON

MSS: MBS: Latch: Commands ► Close:

cmd On

MSS: MBS: Latch:

Verify Mode – On

6. PHASE ONE CAPTURE

MSS: MBS: Latch: Commands ► Close:

cmd First Phase

MSS: MBS: Latch:

Verify 'Command Response' Parameter Checksum Failed – blank

6.353 MBS MCAS LATCH CAPTURE

(RBT GEN/X2R4 - ALL/FIN 4/SPN) Page 3 of 5 pages

MSS: MBS: Latch: Commands ► Close:

MCAS Latch Close Commands

Initframe Details:

MBS IMCA Initframe Details

Verify 'Limits' Position Change – High: 1100 Rev (± 2)

NOTE

1. For MSS: MBS: Latch: **MCAS Latch** 'Motor Status', expect large fluctuations in values for Shaft Speed, Acceleration, and Current. The data is unreliable.
2. The Actuate command will initiate partial closing of the MCAS Latch Mechanism.
3. To pause IMCA motion, mode the IMCA back to On.

MSS: MBS: Latch: Commands ► Close: **MCAS Latch Close Commands**

cmd Actuate

MSS: MBS: Latch: **MCAS Latch**

Verify 'Mode' – Enabled

Verify 'Motor Status' Position – incrementing

Verify 'Mode' – On (~2 minutes, 30 seconds)

Verify 'Motor Status' Position: 1100 Rev (± 2)

Verify 'Latch' Closed – blank

Verify 'Latch' Open – blank

7. [SSRMS CONFIGURATION](#)

PCS

MSS: SSRMS: Limp: **SSRMS Limp**

cmd All Limp (Verify Limp – blue)

MSS: SSRMS: **SSRMS**

Verify all joints – Limped

8. [PHASE TWO CAPTURE](#)

MSS: MBS: Latch: Commands ► Close: **MCAS Latch Close Commands**

cmd Second Phase

MSS: MBS: Latch: **MCAS Latch**

Verify 'Command Response' Parameter Checksum failed – blank

6.353 MBS MCAS LATCH CAPTURE

(RBT GEN/X2R4 - ALL/FIN 4/SPN) Page 4 of 5 pages

MSS: MBS: Latch: Commands ► Close:

[MCAS Latch Close Commands](#)

Initframe Details:

[MBS IMCA Initframe Details](#)

Verify 'Limits' Position Change – High: 1650 Rev (± 2)

NOTE

1. For MSS: MBS: Latch: [MCAS Latch](#) 'Motor Status', expect large fluctuations in values for Acceleration and Current. The data is unreliable.
2. The Actuate command will initiate partial closing of the MCAS Latch Mechanism.
3. To pause IMCA motion, mode IMCA back to On.

MSS: MBS: Latch: Commands ► Close: [MCAS Latch Close Commands](#)

cmd Actuate

MSS: MBS: Latch: [MCAS Latch](#)

Verify 'Mode' – Enabled

Verify 'Motor Status' Position – incrementing

Verify 'Mode' – On (~1 minute, 15 seconds)

Verify 'Motor Status' Position: 1650 Rev (± 2)

Verify 'Latch' Closed – blank

Verify 'Latch' Open – blank

9. [PHASE THREE CAPTURE](#)

MSS: MBS: Latch: Commands ► Close: [MCAS Latch Close Commands](#)

cmd Third Phase

MSS: MBS: Latch: [MCAS Latch](#)

Verify 'Command Response' Parameter Checksum Failed – blank

MSS: MBS: Latch: Commands ► Close:

[MCAS Latch Close Commands](#)

Initframe Details:

[MBS IMCA Initframe Details](#)

Verify 'Limits' Position Change – High: 3110 Rev (± 2)

6.353 MBS MCAS LATCH CAPTURE

(RBT GEN/X2R4 - ALL/FIN 4/SPN) Page 5 of 5 pages

NOTE

1. For MBS: MCAS Latch: **MCAS Latch** 'Motor Status', expect large fluctuations in values for Acceleration and Current. The data is unreliable.
2. The Actuate command will initiate full closing of the MCAS Latch Mechanism.
3. To pause IMCA motion, mode IMCA back to On.

MSS: MBS: Latch: Commands ► Close: **MCAS Latch Close Commands**

cmd Actuate

MSS: MBS: Latch: **MCAS Latch**

Verify 'Mode' – Enabled

Verify 'Motor Status' Position – incrementing

Verify 'Mode' – On (~3 minutes, 20 seconds)

Verify 'Motor Status' Position: 3110 Rev (± 2)

Verify 'Latch' Closed – \checkmark

Verify 'Latch' Open – blank

10. [MODE IMCA TO STANDBY](#)

MSS: MBS: Latch: Commands ► Close: **MCAS Latch Close Commands**

cmd Standby

MSS: MBS: Latch: **MCAS Latch**

Verify 'Mode' – Standby

11. [SSRMS CONFIGURATION](#)

PCS

MSS: SSRMS: Limp: **SSRMS Limp**

cmd None Limp (Verify Standby – blue)

12. [POWER OFF PRIME\(REDUNDANT\) MCAS LATCH IMCA](#)

MSS: MBS: Latch: **MCAS Latch**

Verify 'Active MBS IMCA' – MCAS Latch

Verify 'Power' – On

Verify 'Mode' – Standby

MSS: MBS: Latch: Power: **MCAS Latch IMCA Power**

cmd Off (Verify Off – \checkmark)

MSS: MBS: Latch: **MCAS Latch**

Verify 'Active MBS IMCA' – None

Verify 'Power' – Off

This Page Intentionally Blank

6.354 MBS MCAS LATCH RELEASE

(RBT GEN/X2R4 - ALL/FIN 4/SPN) Page 1 of 3 pages

I

NOTE

1. Expect sporadic '**R4H - MBS MCU MCAS Latch Cat-2 Cksum Fail**' Robotics Advisory messages (SCR 22667).
2. A sporadic '**R4H - MBS MCU MCAS Abnormal Stop Cond**' Robotics Advisory message may be raised when a new IMCA initframe is loaded. This message may be ignored unless it is raised immediately following the end of the IMCA trajectory (SCR 28923).

1. POWER ON PRIME(REDUNDANT) MCAS LATCH IMCA

PCS

MSS: MBS: POA Power:

√'Prime' – Off (Keep-Alive)

√'Redundant' – Off (Keep-Alive)

MSS: MBS:

√'MBS Safing' – Not Safed

MSS: MBS: Latch:

Verify 'Active' MBS IMCA – None

Verify 'Power' – Off

MSS: MBS: Latch: Power:

cmd Enable (Verify – √)

cmd Confirm (Verify – √)

cmd On (Verify – √)

MSS: MBS: Latch:

Verify 'Active MBS IMCA' – MCAS Latch

Verify 'Mode' – Standby (6 seconds)

2. VERIFY POST TESTS

MSS: MBS: Latch: Commands ► BIT:

Verify all – blank

3. SETUP

Configure cameras and overlays as required.

4. SSRMS CONFIGURATION

PCS

MSS: SSRMS: Limp:

cmd All Limp (Verify Limp – blue)

MSS: SSRMS:

Verify All Joints – Limped

6.354 MBS MCAS LATCH RELEASE

(RBT GEN/X2R4 - ALL/FIN 4/SPN) Page 2 of 3 pages

Wait 30 seconds.

MSS: SSRMS: Limp:

cmd None Limp (Verify Standby – blue)

5. INITIALIZE MCAS LATCH IMCA WITH SAFING INITFRAME

MSS: MBS: Latch:

Verify 'Latch' Closed – ✓
Verify 'Latch' Open – blank

MSS: MBS: Latch: Commands ► Open:

cmd Safing Initframe

MSS: MBS: Latch:

Verify 'Command Response' Initframe Received – ✓
Verify 'Command Response' Parameter Checksum Failed – blank

MSS: MBS: Latch: Commands ► Open:

Initframe Details:

Verify 'Limits' Position Change – High: 0 Rev

6. MODE IMCA TO ON

MSS: MBS: Latch: Commands ► Open:

cmd On

MSS: MBS: Latch:

Verify 'Mode' – On

7. FULLY OPEN MCAS LATCH

MSS: MBS: Latch: Commands ► Open:

cmd Fully Open

MSS: MBS: Latch:

Verify 'Command Response' Parameter Checksum Failed – blank

MSS: MBS: Latch: Commands ► Open:

Initframe Details:

6.354 MBS MCAS LATCH RELEASE

(RBT GEN/X2R4 - ALL/FIN 4/SPN) Page 3 of 3 pages

Verify 'Limits' Position Change – High: -3110 Rev (± 2)

NOTE

1. For MSS: MBS: Latch: **MCAS Latch** 'Motor Status', expect large fluctuations in values for Acceleration and Current. The data is unreliable.
2. The Actuate command will initiate full opening of the MCAS Latch Mechanism.
3. To pause IMCA motion, mode IMCA back to On.

MSS: MBS: Latch: Commands ► Open: **MCAS Latch Open Commands**

cmd Actuate

MSS: MBS: Latch: **MCAS Latch**

Verify 'Mode' – Enabled

Verify 'Motor Status' Position – decrementing

Verify 'Mode' – On (~7 minutes)

Verify 'Motor Status' Position: -3110 Rev (± 2)

Verify 'Latch' Closed – blank

Verify 'Latch' Open – \surd

8. MODE IMCA TO STANDBY

MSS: MBS: Latch: Commands ► Open: **MCAS Latch Open Commands**

cmd Standby

MSS: MBS: Latch: **MCAS Latch**

Verify Mode – Standby

9. POWER OFF PRIME(REDUNDANT) MCAS LATCH IMCA

MSS: MBS: Latch: **MCAS Latch**

Verify 'Active MBS IMCA' – MCAS Latch

Verify 'Power' – On

Verify 'Mode' – Standby

MSS: MBS: Latch: Power: **MCAS Latch IMCA Power**

cmd Off (Verify Off – \surd)

MSS: MBS: Latch: **MCAS Latch**

Verify 'Active MBS IMCA' – None

Verify 'Power' – Off

This Page Intentionally Blank

NOTE

1. Only one MBS mechanism (MCAS UMA, MTCL, POA or MCAS Latch) can be Operational at one time.
2. Expect sporadic '**R4H - MBS MCU MCAS UMA Cat-2 Cksum Fail**' Robotics Advisory messages (SCR 22667).
3. A sporadic '**R4H - MBS MCU MCAS Abnormal Stop Cond**' Robotics Advisory message may be raised when a new IMCA init frame is loaded. This message may be ignored unless it is raised immediately following the end of the IMCA trajectory (SCR 28923).

PCS 1. SETUP
 MSS: MBS: POA Power:

Verify 'Prime' – Keep-Alive(Off)
 Verify 'Redundant' – Keep-Alive(Off)

MSS: MBS: UMA:

Verify 'Active MBS IMCA' – None

2. CANCEL MBS SAFING
 MSS: MBS: MBS Safing:

cmd Remove (Verify Not Safed)

3. POWER ON MCAS UMA IMCA
 MSS: MBS: UMA: Power:

cmd Enable (Verify – √)
cmd Confirm (Verify – √)
cmd On (Verify – √)

MSS: MBS: UMA:

Verify 'Power' – On (6 seconds)

4. VERIFY POST AND BIT TESTS
 MSS: MBS: UMA: Commands ► BIT:

Verify all – blank

6.360 MBS MCAS UMA MATE

(RBT GEN/X2R4 - ALL/FIN 4)

Page 2 of 4 pages

5. INITIALIZE MCAS UMA IMCA WITH SAFING INITFRAME

MSS: MBS: UMA:

Verify 'Mated' – blank

Verify 'Demated' – √

MSS: MBS: UMA: Commands ► Mate:

cmd Safing Initframe

MSS: MBS: UMA:

'Command Response'

Verify 'Initframe Received' – √

Verify 'Parameter Checksum Failed' – blank

MSS: MBS: UMA: Command ► Mate: Initframe Details:

Verify 'Limits' 'Position Change – High': 0

MSS: MBS: UMA: Commands ► Mate:

cmd On

MSS: MBS: UMA:

Verify 'Mode' – On

6. THRUSTERS INHIBIT

If ISS/orbiter mated

MSS: SSRMS: Thrusters:

cmd 'Desat Request' Inhibit (Verify – Inh)

√'Auto Att Control Handover to RS' – Inh

If ISS not mated to orbiter, √**MCC-H** for proper thruster configuration before proceeding.

7. FIRST STAGE MATE

MSS: MBS: UMA: Commands ► Mate:

cmd First Phase

MSS: MBS: UMA:

Verify 'Command Response' 'Parameter Checksum Failed' – blank

MSS: MBS: UMA: Commands ► Mate: Initframe Details:

Verify 'Limits' 'Position Change – High': -450

6.360 MBS MCAS UMA MATE

(RBT GEN/X2R4 - ALL/FIN 4)

Page 3 of 4 pages

NOTE

For MSS: MBS: UMA: **MCAS UMA** 'Motor Status', expect large fluctuations in values for Acceleration and Current. The data is unreliable.

MSS: MBS: UMA: Commands ► Mate: **MCAS UMA Mate Commands**

cmd Actuate

MSS: MBS: UMA: **MCAS UMA**

Verify 'Mode' – Enabled

Verify 'Motor Status' 'Position' – decrementing

Verify 'Mode' – On (~1 minute)

Verify 'Motor Status' 'Position': -450 ± 2

Verify 'Mated' – blank

Verify 'Demated' – blank

8. SECOND STAGE MATE

MSS: MBS: UMA: Commands ► Mate: **MCAS UMA Mate Commands**

cmd Second Phase

MSS: MBS: UMA: **MCAS UMA**

Verify 'Command Response' 'Parameter Checksum Failed' – blank

MSS: MBS: UMA: Commands ► Mate: Initframe Details:

MBS IMCA Initframe Details

Verify 'Limits' 'Position Change – High': -516

NOTE

1. For MSS: MBS: UMA: **MCAS UMA** 'Motor Status', expect large fluctuations in values for Acceleration and Current. The data is unreliable.
2. A timing problem between the MCU and IMCA may cause the MBS to safe and remove power from the UMA IMCAS after the mated microswitch is tripped. The following messages will be raised for one cycle:
'R20 – MBS MCU UMA Inadvertent Pwr On'
'R2P – MSS OCS MBS Prime(Redun) MCU SRT Inh Fail'
'R4H – MBS MCU UMA Stop Cond Err'
(SCR 28152).

The state of the mated microswitch can be verified by canceling Safing and applying power to the UMA IMCA.

6.360 MBS MCAS UMA MATE

(RBT GEN/X2R4 - ALL/FIN 4)

Page 4 of 4 pages

MSS: MBS: UMA: Commands ► Mate: MCAS UMA Mate Commands

cmd Actuate

MSS: MBS: UMA: MCAS UMA

Verify 'Mode' – Enabled

Verify 'Motor Status' 'Position' – decrementing

Verify 'Mode' – On (~35 seconds)

Verify 'Latch Status' – Switch 1

Verify 'Motor Status' 'Position': -505 ± 5

Verify 'Mated' – \surd

Verify 'Demated' – blank

9. MODE IMCA TO STANDBY

MSS: MBS: UMA: Commands ► Mate: MCAS UMA Mate Commands

cmd Standby

MSS: MBS: UMA: MCAS UMA

Verify 'Mode' – Standby

10. IMCA POWER REMOVAL

MSS: MBS: UMA: Power: MCAS UMA IMCA Power

cmd Off (Verify – \surd)

11. THRUSTERS ENABLE

If ISS/orbiter mated

MSS: SSRMS: Thrusters: Thruster Controls for MSS Ops

cmd 'Desat Request' Enable (Verify – Ena)

If ISS not mated to orbiter, \surd **MCC-H** for proper thruster configuration.

6.361 MBS MCAS UMA DEMATE

(RBT GEN/X2R4 - ALL/FIN 4/SPN) Page 1 of 5 pages

I

NOTE

1. Only one MBS mechanism (MCAS UMA, MTCL, POA or MCAS Latch) can be Operational at one time.
2. Expect sporadic '**R4H - MBS MCU MCAS UMA Cat-2 Cksum Fail**' Robotics Advisory messages (SCR 22667).
3. A sporadic '**R4H - MBS MCU MCAS Abnormal Stop Cond**' Robotics Advisory message may be raised when a new IMCA init frame is loaded. This message may be ignored unless it is raised immediately following the end of the IMCA trajectory (SCR 28923).

PCS 1. SETUP
MSS: MBS: POA Power:

Verify 'Prime' – Keep-Alive(Off)
Verify 'Redundant' – Keep-Alive(Off)

MSS: MBS: UMA:

Verify 'Active MBS IMCA' – None

2. CANCEL MBS SAFING
MSS: MBS: MBS Safing:

cmd Remove (Verify Not Safed)

3. POWER ON MCAS UMA IMCA
MSS: MBS: UMA: Power:

cmd Enable (Verify – √)
cmd Confirm (Verify – √)
cmd On (Verify – √)

MSS: MBS: UMA:

Verify 'Power' – On (6 seconds)

4. VERIFY POST AND BIT TESTS
MSS: MBS: UMA: Commands ► BIT:

Verify all – blank

6.361 MBS MCAS UMA DEMATE

(RBT GEN/X2R4 - ALL/FIN 4/SPN) Page 2 of 5 pages

5. INITIALIZE MCAS UMA IMCA WITH SAFING INITFRAME

MSS: MBS: UMA: MCAS UMA

Verify 'Mated' – √

Verify 'Demated' – blank

MSS: MBS: UMA: Commands ► Demate: MCAS UMA Demate Commands

cmd Safing Initframe

MSS: MBS: UMA: MCAS UMA

'Command Response'

Verify 'Initframe Received' – √

Verify 'Parameter Checksum Failed' – blank

MSS: MBS: UMA: Commands ► Demate: Initframe Details:

MBS IMCA Initframe Details

Verify 'Limits' 'Position Change – High': 0

MSS: MBS: UMA: Commands ► Demate: MCAS UMA Demate Commands

cmd On

MSS: MBS: UMA: MCAS UMA

Verify 'Mode' – On

6. THRUSTERS INHIBIT

If ISS/orbiter mated

MSS: SSRMS: Thrusters: Thruster Controls for MSS Ops

cmd 'Desat Request' Inhibit (Verify – Inh)

√'Auto Att Control Handover to RS' – Inh

If ISS not mated to orbiter, √**MCC-H** for proper thruster configuration before proceeding.

7. FIRST STAGE DEMATE

MSS: MBS: UMA: Commands ► Demate: MCAS UMA Demate Commands

cmd First Phase

MSS: MBS: UMA: MCAS UMA

Verify 'Command Response' 'Parameter Checksum Failed' – blank

6.361 MBS MCAS UMA DEMATE

(RBT GEN/X2R4 - ALL/FIN 4/SPN) Page 3 of 5 pages

MSS: MBS: UMA: Commands ► Demate: Initframe Details:
MBS IMCA Initframe Details

Verify 'Limits' 'Position Change – High': 450

NOTE

For MSS: MBS: UMA: MCAS UMA 'Motor Status', expect large fluctuations in values for Acceleration and Current. The data is unreliable.

MSS: MBS: UMA: Commands ► Demate: MCAS UMA Demate Commands

cmd Actuate

MSS: MBS: UMA: MCAS UMA

Verify 'Mode' – Enabled

Verify 'Motor Status' 'Position' – incrementing

Verify 'Mode' – On (~1 minute)

Verify 'Motor Status' 'Position': 450 ± 2

Verify 'Mated' – blank

Verify 'Demated' – blank

8. SECOND STAGE DEMATE

MSS: MBS: UMA: Commands ► Demate: MCAS UMA Demate Commands

cmd Second Phase

MSS: MBS: UMA: MCAS UMA

Verify 'Command Response' 'Parameter Checksum Failed' – blank

MSS: MBS: UMA: Commands ► Demate: Initframe Details:
MBS IMCA Initframe Details

Verify 'Limits' 'Position Change – High': 516

6.361 MBS MCAS UMA DEMATE

(RBT GEN/X2R4 - ALL/FIN 4/SPN) Page 4 of 5 pages

NOTE

1. For MSS: MBS: UMA: **MCAS UMA** 'Motor Status', expect large fluctuations in values for Acceleration and Current. The data is unreliable.
2. A timing problem between the MCU and IMCA may cause the MBS to safe and remove power from the UMA IMCAS after the demated microswitch is tripped. The following messages will be raised for one cycle:
 'R20 – MBS MCU UMA Inadvertent Pwr On'
 'R2P – MSS OCS MBS Prime(Redun) MCU SRT Inh Fail'
 'R4H – MBS MCU UMA Stop Cond Err'
 (SCR 28152).
 The state of the demated microswitch can be verified by canceling Safing, and applying power to the UMA IMCA.

MSS: MBS: UMA: Commands ► Demate: **MCAS UMA Demate Commands**

cmd Actuate

MSS: MBS: UMA: **MCAS UMA**

Verify 'Mode' – Enabled

Verify 'Motor Status' 'Position' – incrementing

Verify 'Mode' – On (~35 seconds)

Verify 'Latch Status' – Switch 2

Verify 'Motor Status' 'Position': 505 ± 5

Verify 'Mated' – blank

Verify 'Demated' – \surd

9. MODE IMCA TO STANDBY

MSS: MBS: UMA: Commands ► Demate: **MCAS UMA Demate Commands**

cmd Standby

MSS: MBS: UMA: **MCAS UMA**

Verify 'Mode' – Standby

10. IMCA POWER REMOVAL

MSS: MBS: UMA: Power: **MCAS UMA IMCA Power**

cmd Off (Verify – \surd)

6.361 MBS MCAS UMA DEMATE

(RBT GEN/X2R4 - ALL/FIN 4/SPN) Page 5 of 5 pages

11. THRUSTERS ENABLE

If ISS/orbiter mated

MSS: SSRMS: Thrusters: Thruster Controls for MSS Ops

cmd 'Desat Request' Enable (Verify – Ena)

If ISS not mated to orbiter, \surd **MCC-H** for proper thruster configuration.

This Page Intentionally Blank

6.421 LEE CALIBRATION

(RBT GEN/E10 - ALL/FIN 4/SPN) Page 1 of 1 page

I

NOTE

A Calibrate command may be aborted by a '**SSRMS LEE LEU Mtr Velocity Runaway**' Robotics Advisory message, and the MSS safed if one of the three LEE mechanisms was initially located at the hardstop position. If safing occurs, cancel safing and restart this procedure from the beginning (SCR 20379).

PCS

MSS: SSRMS:

Verify Unloaded Parameters – √

MSS: SSRMS: Tip LEE:

cmd 'LEE Mechanism' – Calibrate

Verify '**Confirm or Terminate**' prompt.

CAUTION

Due to end-to-end system latency, the RHC Trigger is hot up to 3 seconds prior to receiving a Trigger Hot Icon status on the PCS.

NOTE

Once the trigger is hot, only safing or trigger commands should be sent to the Robotics equipment. If a configuration change is required, including routing MSS cameras, safe the system to exit LEE operations (SCR 23262, 14662).

cmd Confirm (Verify RHC Trigger Hot Icon)

NOTE

1. Apply safing to stop mechanism motion (SCR 23262, 14662).
2. Calibration might take up to 5 minutes, 40 seconds to complete.

RHC

TRIGGER → press (momentarily)

PCS

Verify 'Snare' Open – blue
Verify 'Carriage' Extend – blue
Verify 'Latch' Unlatch – blue
Verify 'LEE Mechanisms' – Calibrated
Verify 'Load Cell' – Calibrated
Verify 'Motors' – Inh (340 s max)

This Page Intentionally Blank

6.422 LEE CHECKOUT

(RBT GEN/E10 - ALL/FIN 3/SPN)

Page 1 of 3 pages

I

1. SETUP

PCS

MSS: SSRMS:

Verify Unloaded Parameters – √

DCP

√BRAKES SSRMS ON –

If SSRMS wrist configuration is not

WP	WY
-20.0	-170.0

Note current wrist configuration.

WP	WY

DCP

BRAKES SSRMS → OFF (Verify OFF)

PCS

MSS: SSRMS:

√Vernier

input Mode – Single (Verify Single – blue)

WARNING

The active joint must be checked on the PCS before initiating motion. Failure to do so may result in movement of the wrong joint.

THC

Maneuver to the following wrist configuration.

WP	WY
-20.0	-170.0

DCP

BRAKES SSRMS → ON (Verify ON)

NOTE

The LEE mechanisms are now visible through the Tip Elbow Camera.

2. LEE SETUP FOR CAPTURE

PCS

MSS: SSRMS: Tip LEE:

√'LEE Mechanisms' – Calibrated

6.422 LEE CHECKOUT

(RBT GEN/E10 - ALL/FIN 3/SPN)

Page 2 of 3 pages

```
*****
* If LEE Mechanisms – Not Calibrated
* |   Perform {6.421 LEE CALIBRATION}, all (SODF: RBT GEN:
* |   NOMINAL), then:
*****
```

√'Setup' – Yes

```
*****
* If 'Setup' – No
* |   Perform {6.428 LEE SETUP FOR CAPTURE},
* |   all (SODF: RBT GEN: NOMINAL), then:
*****
```

3. SLOW(FAST) LEE CHECKOUT

NOTE

Checkout should be run with slow speed unless otherwise specified.

cmd Checkout ► Slow(Fast) (Verify 'Speed' – Slow(Fast))

Verify '**Confirm or Terminate**' prompt.

CAUTION

Due to end-to-end system latency, the RHC Trigger is hot up to 3 seconds prior to receiving a Trigger Hot icon status on the PCS.

NOTE

Once the trigger is hot, only safing or trigger commands should be sent to the Robotics equipment. If a configuration change is required, including routing MSS cameras, safe the system to exit LEE operations (SCR 23262, 14662).

cmd Confirm (Verify RHC Trigger Hot icon)

NOTE

Apply safing to stop mechanism motion (SCR 23262, 14662).

RHC

TRIGGER → press (momentarily)

6.422 LEE CHECKOUT

(RBT GEN/E10 - ALL/FIN 3/SPN)

Page 3 of 3 pages

PCS	Verify 'Snare' Close	– blue (12 s(3 s) max)
	Verify 'Carriage' Retract	– blue (90 s(18 s)max)
	Verify 'Latch' Latch	– blue (65 s(13 s)max)
	Verify 'Umbilical' Mate	– blue (10 s max)
	Verify 'Umbilical' Demate	– blue (10 s max)
	Verify 'Latch' Unlatch	– blue (65 s(13 s) max)
	Verify 'Carriage' Derigidize	– blue (90 s(18 s) max)
	Verify 'Snare' Open	– blue (12 s(3 s) max)
	Verify 'Carriage' Extend	– blue (90 s(18 s) max)

4. RECONFIGURE WRIST

If wrist joints were reconfigured for the checkout

DCP BRAKES SSRMS → OFF (Verify OFF)

PCS MSS: SSRMS:

√Vernier

input Mode – Single (Verify Single – blue)

WARNING

The active joint must be checked on the PCS before initiating motion. Failure to do so may result in movement of the wrong joint.

THC Maneuver back to original wrist configuration as recorded in step 1.

DCP BRAKES SSRMS → ON (Verify ON)

This Page Intentionally Blank

6.428 LEE SETUP FOR CAPTURE

(RBT GEN/E10 - ALL/FIN 3/SPN) Page 1 of 1 page

I

PCS MSS: SSRMS:

Verify Unloaded Parameters – ✓

MSS: SSRMS: Tip LEE:

If Setup – Yes >>

cmd Capture ► Setup ► Slow (Verify Speed – Slow)

Verify '**Confirm or Terminate**' prompt.

CAUTION

Due to end-to-end system latency, the RHC Trigger is hot up to 3 seconds prior to receiving a Trigger Hot icon status on the PCS.

NOTE

Once the trigger is hot, only safing or trigger commands should be sent to the Robotics equipment. If a configuration change is required, including routing MSS cameras, safe the system to exit LEE operations (SCR 23262, 14662).

cmd Confirm (Verify RHC Trigger Hot icon)

Verify LEE Mode – Setup for Capture

RHC TRIGGER → press (momentarily)

PCS
Verify 'Snare' Open – blue
Verify 'Carriage' Extend – blue
Verify 'Latch' Unlatch – blue
Verify Motors – Inh (340 s max)

This Page Intentionally Blank

6.609 CUP(LAB) ARTIFICIAL VISION UNIT (AVU) POWERDOWN

(RBT GEN/R2 - ALL/FIN 2) Page 1 of 1 page

NOTE

Where applicable, AVU Keyboard Hotkeys are shown in the following manner: "hotkey".

1. [AVU SHUTDOWN](#)

Verify system is in Hold.

LCDM

`Space Vision System`

cmd Advanced [Alt-A]

sel File [Alt-F] ► Exit

cmd Don't Save

cmd Shutdown

AVU
KYBD

In the QNX shell on the LCDM, input – `p h s h u t d o w n`

cmd Enter

LCDM

Verify '**System may now be powered down**' message appears.

2. [SWITCH LCDM MODE](#)

LCDM

cmd MENU (Verify Brightness)

cmd UP (Verify Video Mode)

cmd SELECT (Verify COMPOSITE)

cmd UP (Verify RGB)

cmd SELECT

3. [AVU POWERDOWN](#)

PCS

MSS: LAS5(LAP5) AVU: `LAS5(LAP5) AVU`

NOTE

Expect two '**R1E - MSS Active OCS AVU Comm Fail**' Robotics Advisory messages after commanding AVU to Off. Both messages should return to Norm (SCR 17439).

cmd 'Power' Off

4. [POWER STATUS](#)

PCS

MSS: `RWS`

Verify 'LAS5'('LAP5') RPC3 – Open (gray)

Verify 'LAS5'('LAP5') Status from OCS – Off

This Page Intentionally Blank

MSS

7.001 MSS FAILURE RESPONSE AND RECOVERY

(RBT GEN/X2R4 - ALL/FIN/SPN)

Page 1 of 26 pages

C&W
ROBOTICS

C&W Messages
Starting with
'Rxx - ...'

MSS or ISS
Failure Causing
Robotics C&W
Messages and/or
Interruption to
Robotics
Operations.

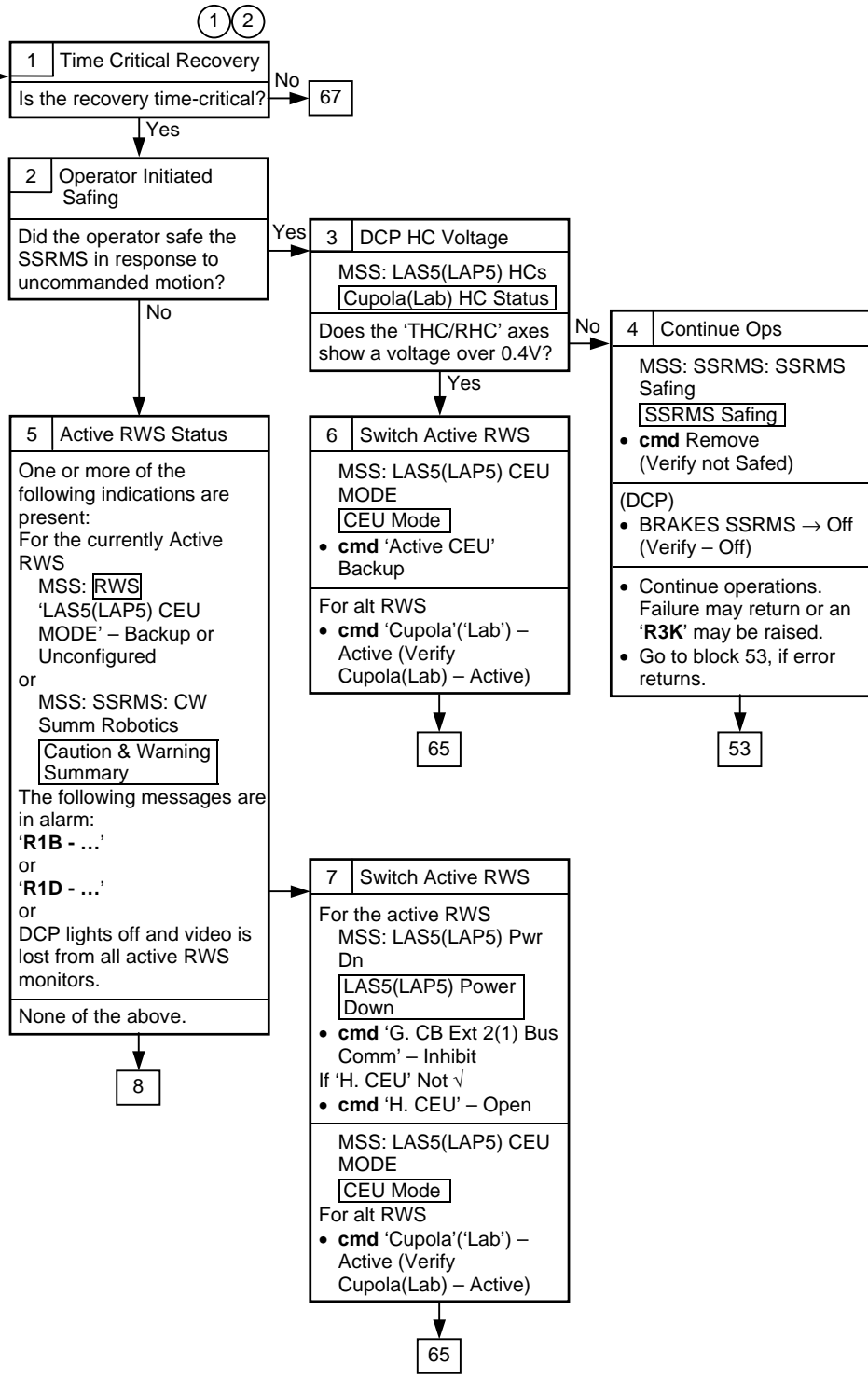

① Unless otherwise indicated, all displays in the procedures are on the PCS.

② Time-critical recovery is intended to regain MSS functionality (SSRMS motion capability) in situations where immediate operator response is required to ensure the safety of the crew, ISS, or a visitation vehicle. Time-critical recovery can be performed by the on-orbit crew without assistance from the ground.

Time-critical recovery steps do not account for MT, LEE or any MBS mechanism failures.

Time-critical recovery assumes the MSS is configured as follows:

- One RWS Backup
- One RWS Active
- SSRMS Operational with video system powered
- MBS Operational on one string with video system powered, Keep-Alive on the other.

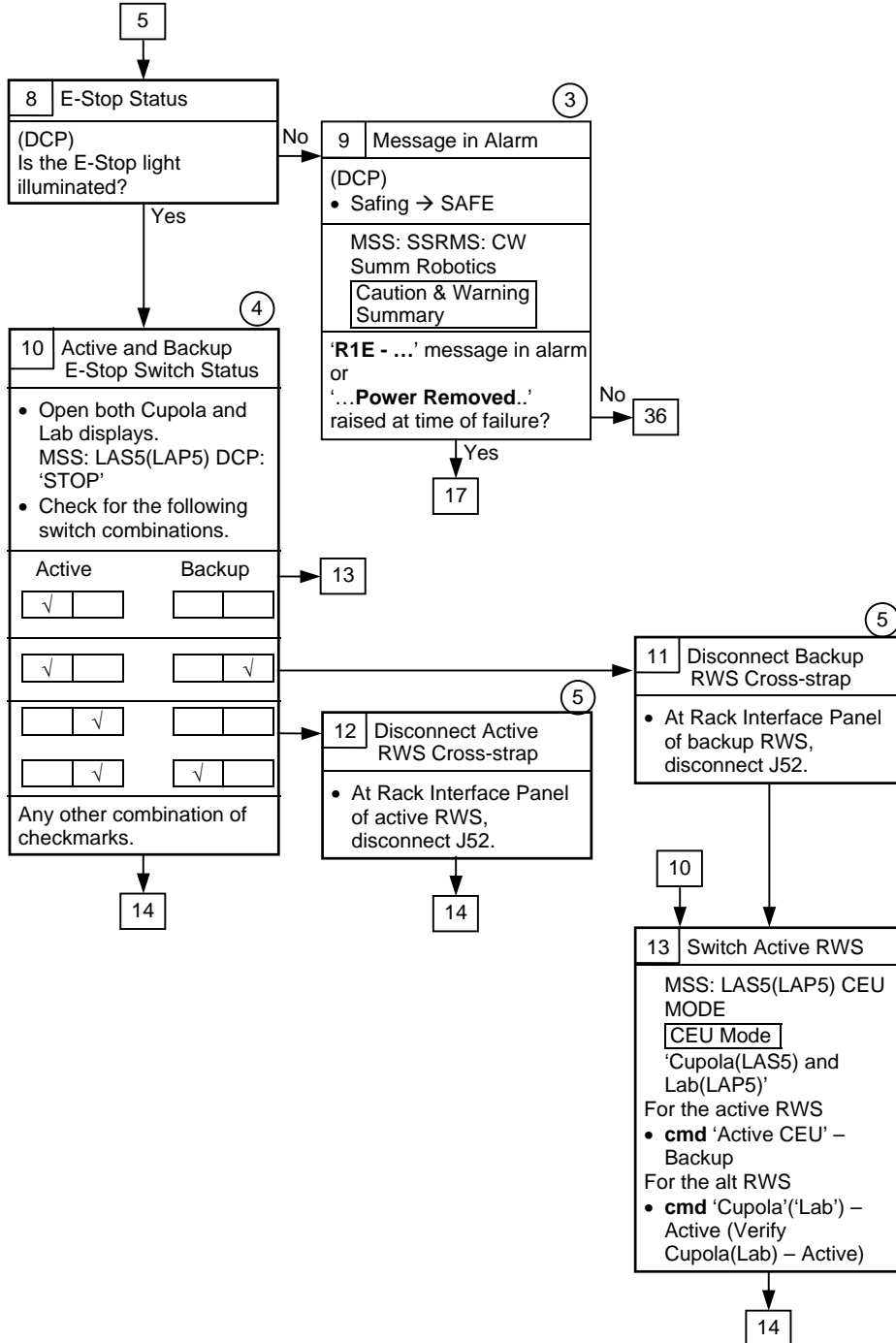

③
SCR 22615, 23233,
19378, 21737

④
The E-Stop Reset
command is not
issued in this
procedure to
prevent removal of
power in case of
failed E-stop switch
contact on either the
Active or Backup
RWS.

⑤
Cross-strap
disconnect inhibits
ability of backup
RWS to safe system
via backup RWS
safing switch. E-stop
still functional at
failed RWS.

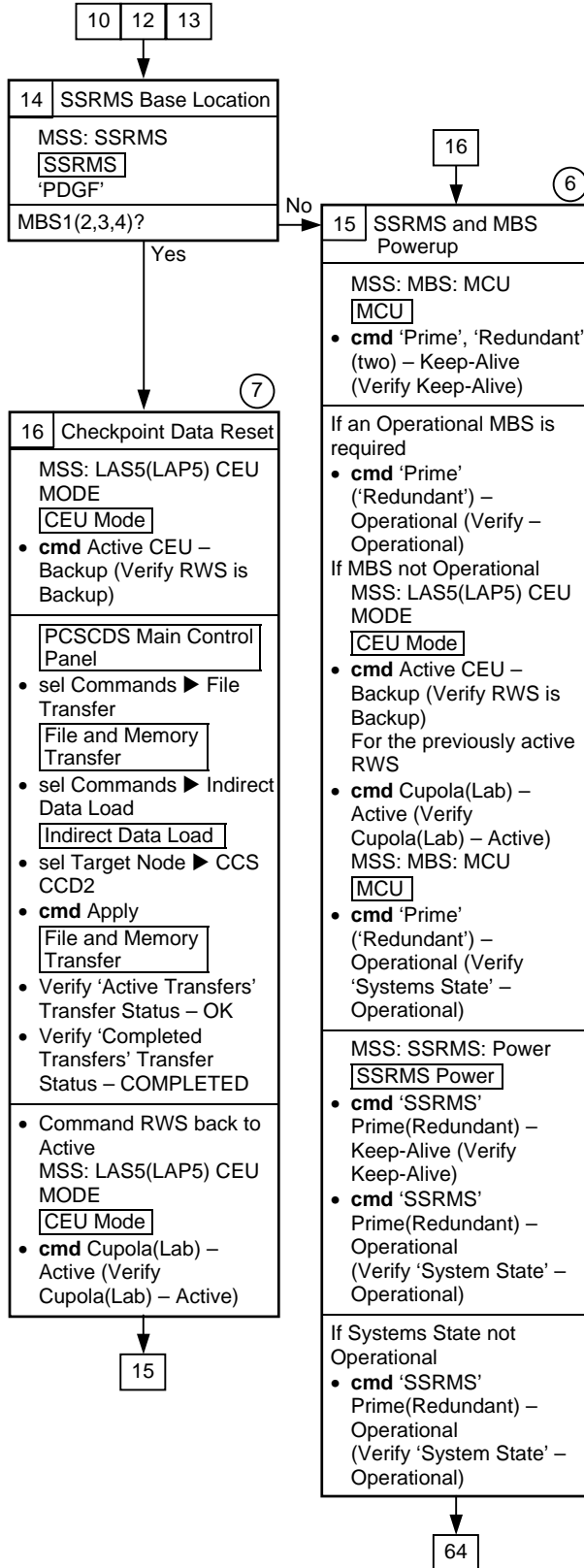

⑥
Power up the previously operational strings. Due to a known SPN condition (SCR 20380), the MBS and SSRMS power to operational commands may not complete after the first attempt.

⑦
SCR 21749

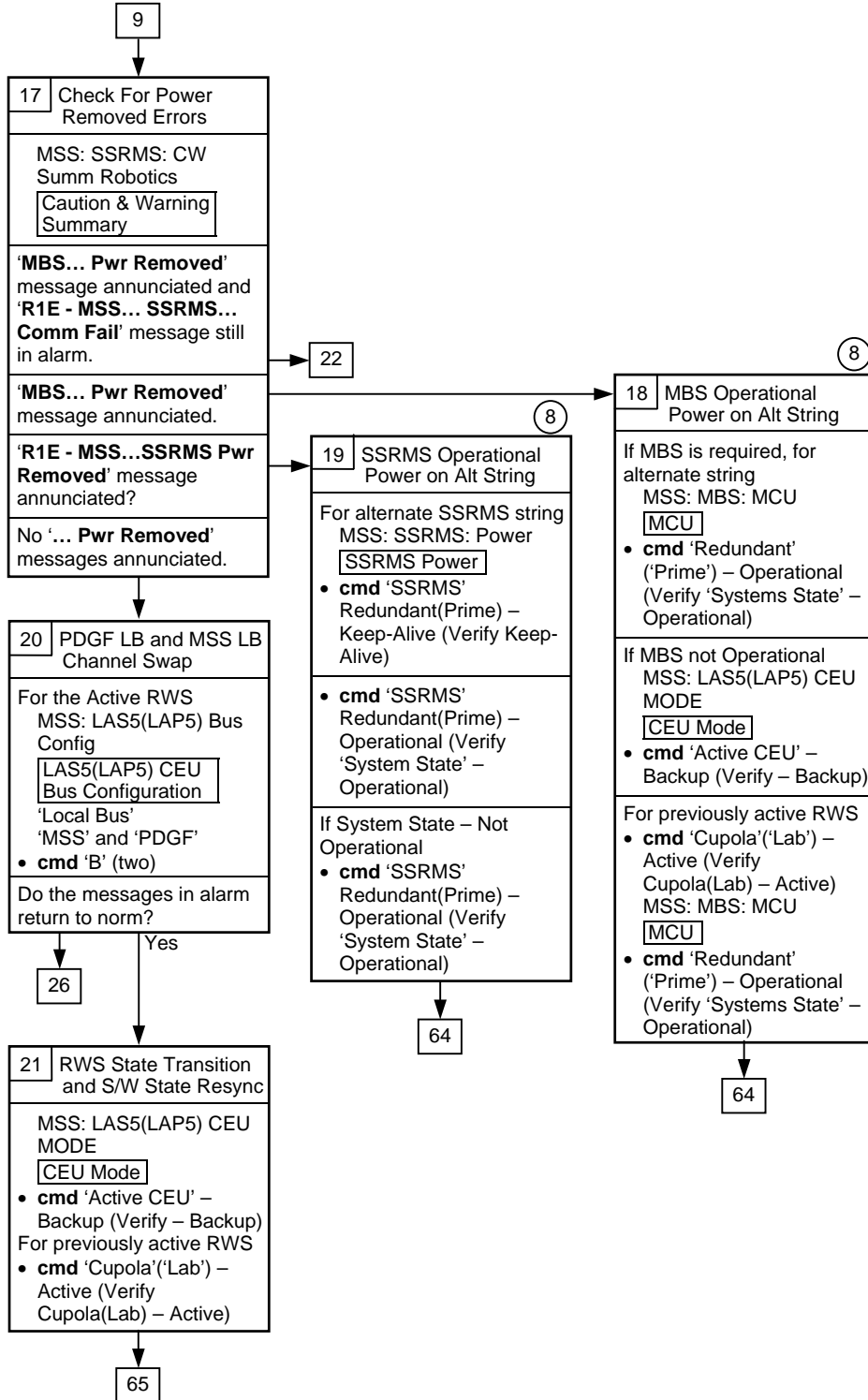

8 Due to a known SPN condition (SCR 20380), the MBS and SSRMS power to operational commands may not complete after the first attempt.

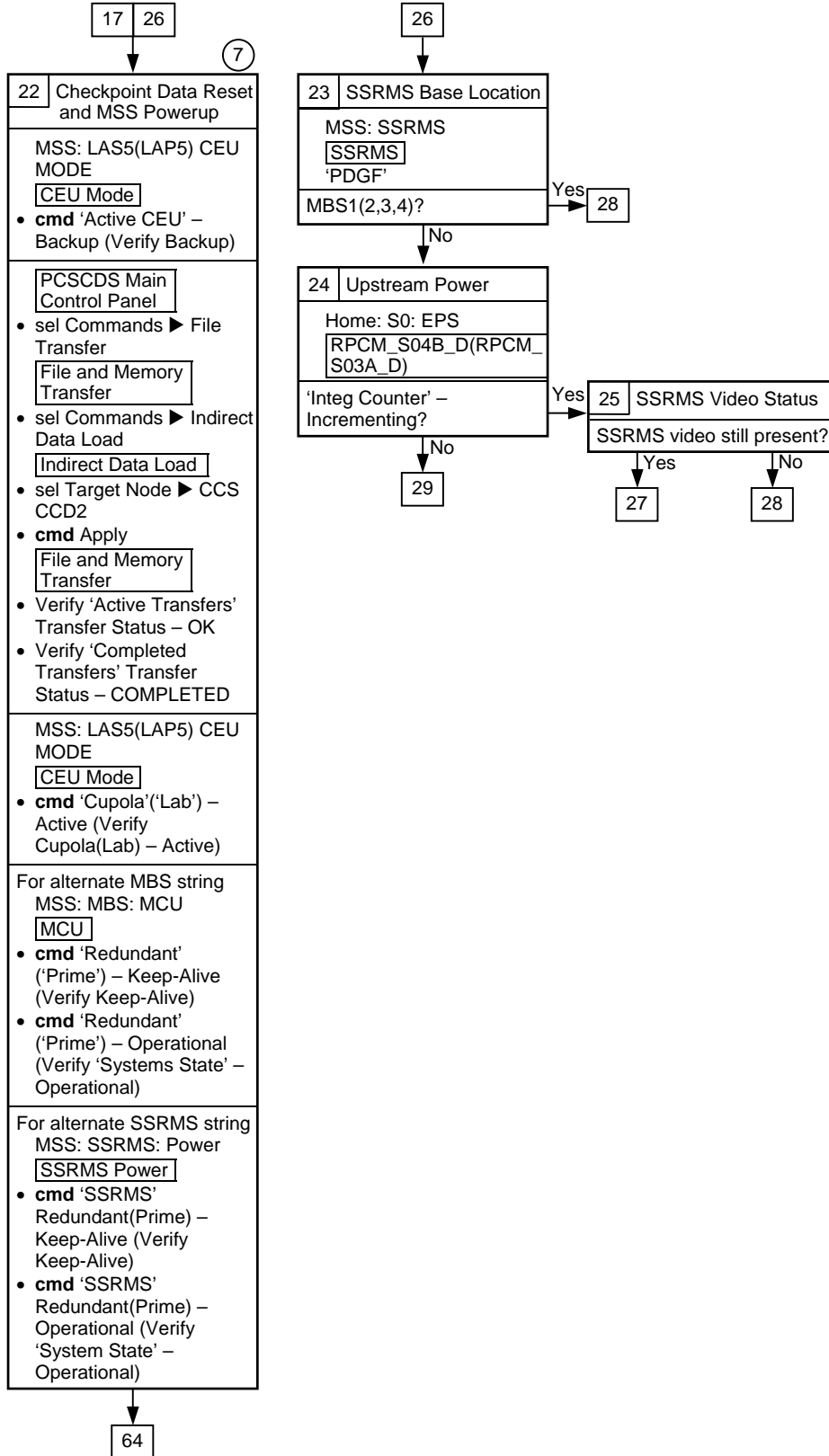

7
 SCR 21749

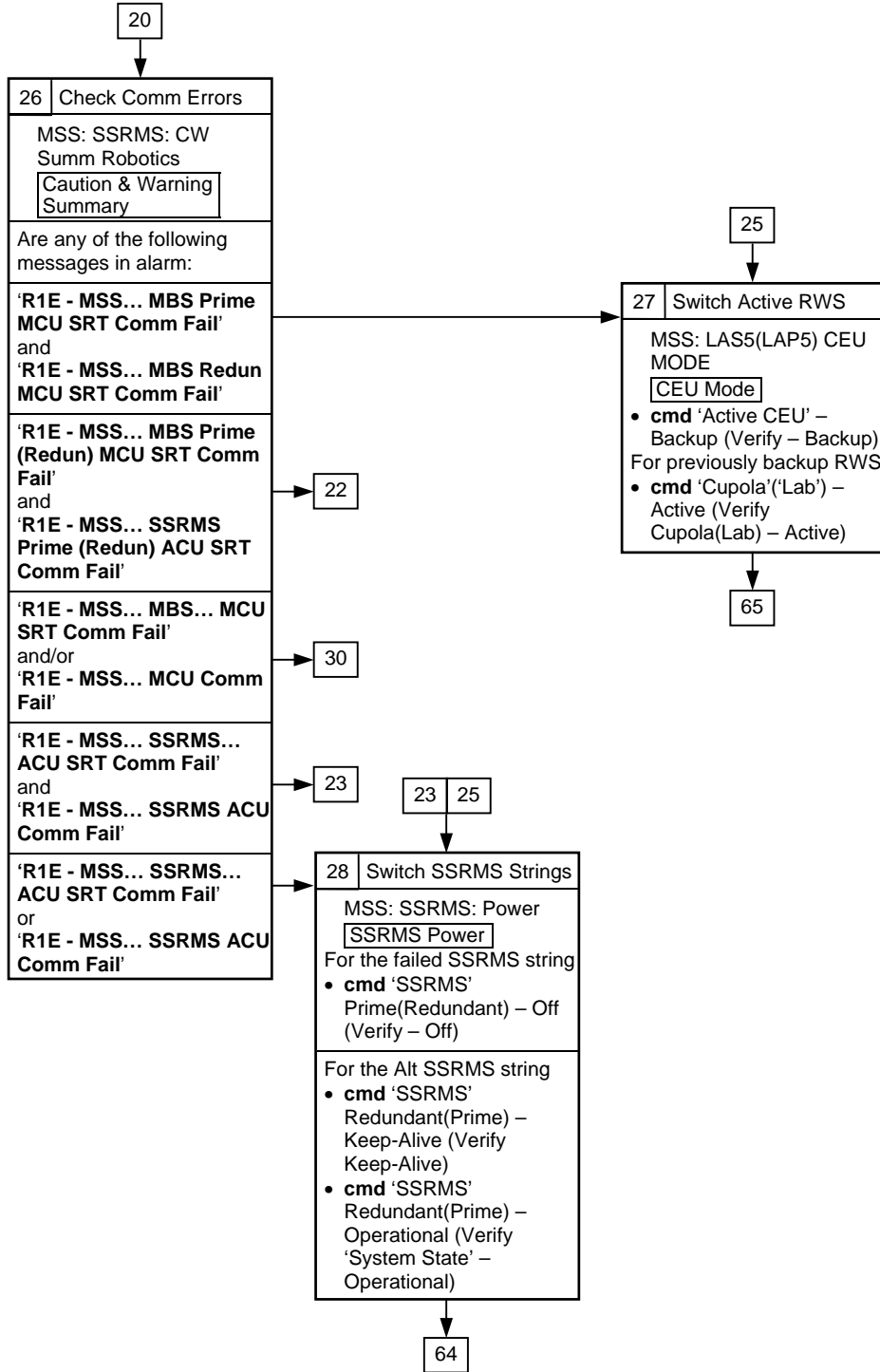

24

29 Checkpoint Data Recovery and MSS Powerup on Alt String

MSS: MBS: MCU
MCU

- cmd 'Prime' – Off (Verify – Off)
- cmd 'Redundant' – Off (Verify – Off)

MSS: LAS5(LAP5) CEU MODE
CEU Mode

- cmd 'Active CEU' – Backup (Verify Backup)

PCSCDS Main Control Panel

- sel Commands ► File Transfer
File and Memory Transfer
- sel Commands ► Indirect Data Load
Indirect Data Load
- sel Target Node ► CCS CCD2
- cmd Apply
File and Memory Transfer
- Verify 'Active Transfers' Transfer Status – OK
- Verify 'Completed Transfers' Transfer Status – COMPLETED

MSS: LAS5(LAP5) CEU MODE
CEU Mode

- cmd 'Cupola'('Lab') – Active (Verify Cupola(Lab) – Active)

MSS: MBS: MCU
MCU

- cmd 'Prime' – Keep-Alive (Verify Keep-Alive)
- cmd 'Redundant' – Keep-Alive (Verify Keep-Alive)

If Operational MBS is required

- cmd 'Prime' ('Redundant') – Operational (Verify 'Systems State' – Operational)

For alternate SSRMS string:
MSS: SSRMS: Power
SSRMS Power

- cmd 'SSRMS' Redundant(Prime) – Keep-Alive (Verify Keep-Alive)
- cmd 'SSRMS' Redundant(Prime) – Operational (Verify 'System State' – Operational)

64

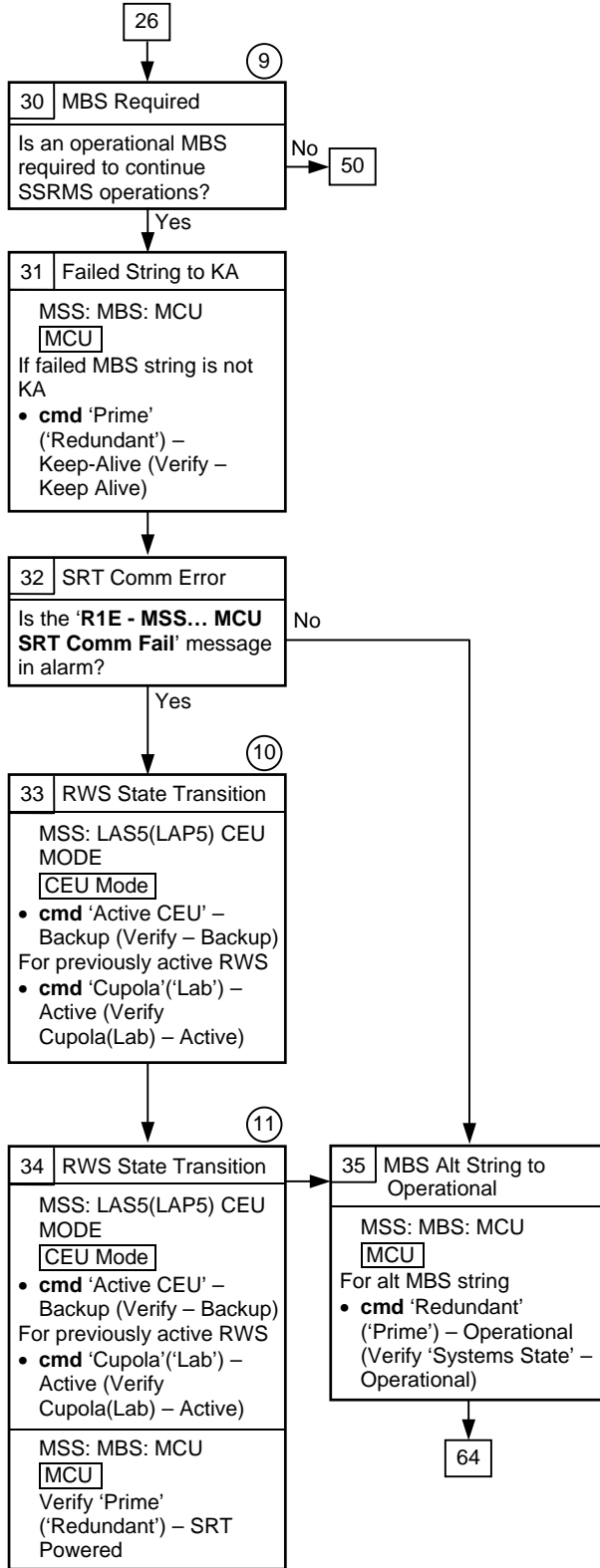

9 An operational MBS is required to power the MBS Mast Camera and light, as well as route/deroute its view. An operational MBS is not required to control pan/tilt/zoom/focus if the camera has already been routed.

10 Expect 'R1E - MSS... MCU SRT Comm Fail' to return into alarm and the MCU state to become SRT Powered.

11 The RWS state transition in the block is required even if it has been executed once already in block 33.

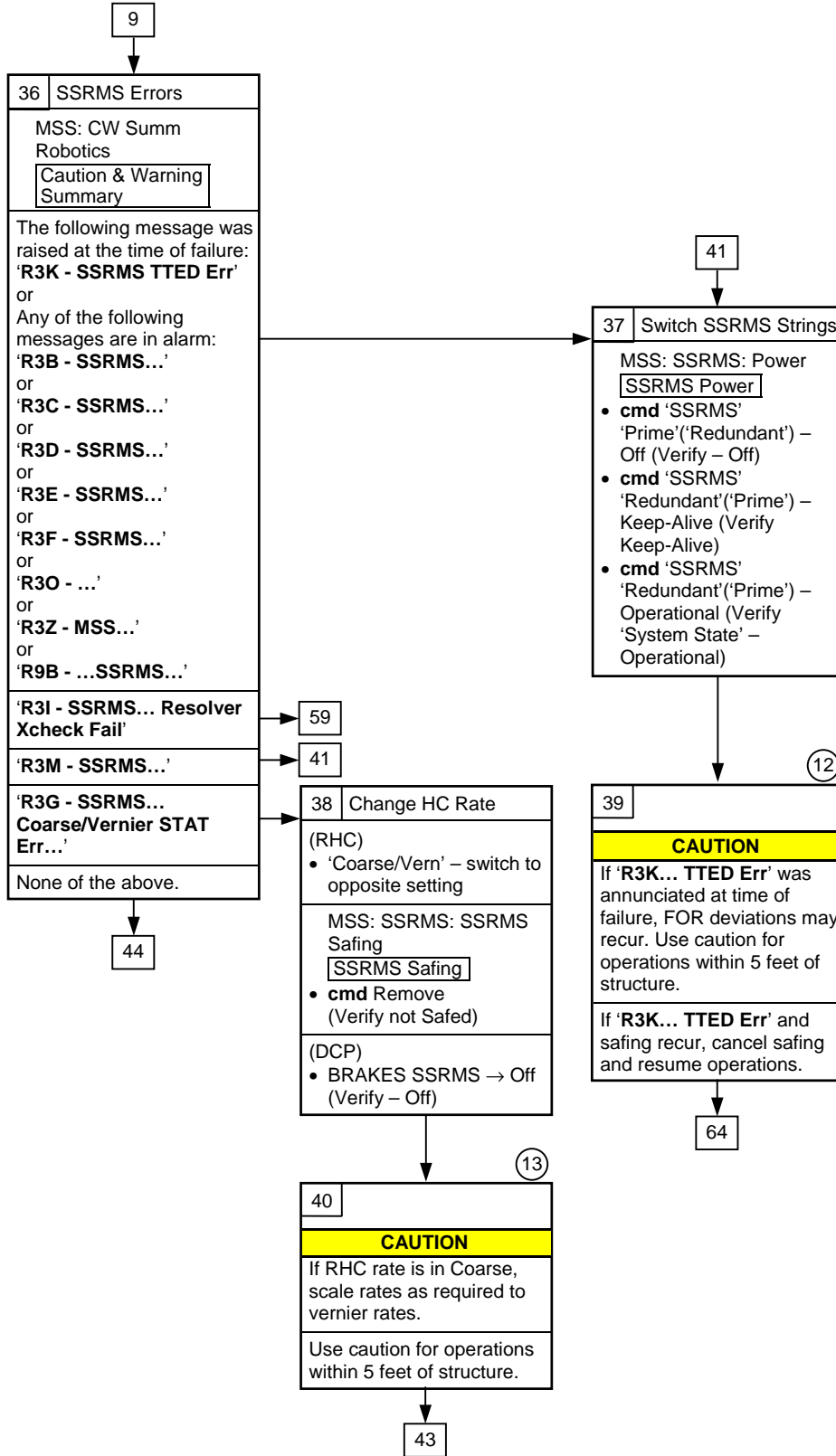

12 Single joint mode can be used to avoid R3K errors.

13 If failure is 'R3G - SSRMS ACU Coarse/Vernier Stat ERR' and RHC rate is in Coarse, MSS powerdown or RWS state transition removes string functionality. If failure is 'R3G - SSRMS SR (SY, SP, EP, WP, WY, WR) Coarse/Vernier Stat ERR' and RHC rate is in Coarse, DJOPS is available to recover current string functionality in the case of a MSS Powerdown or RWS state transition.

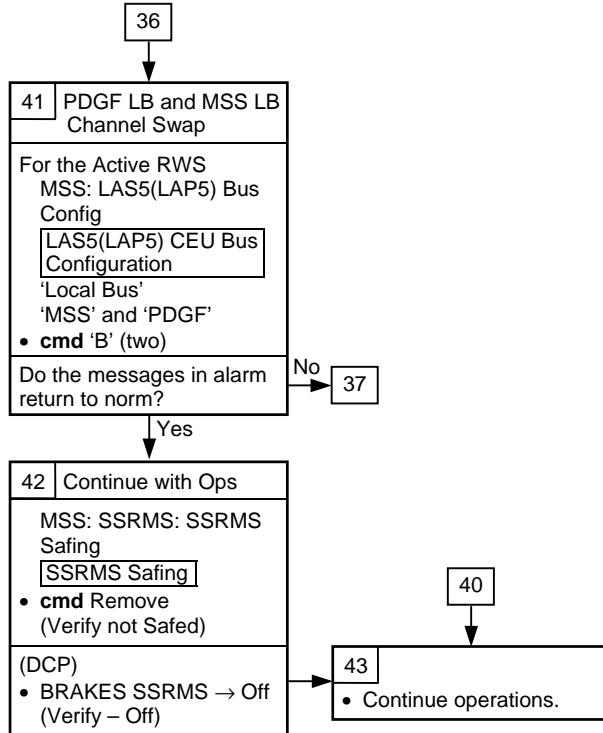

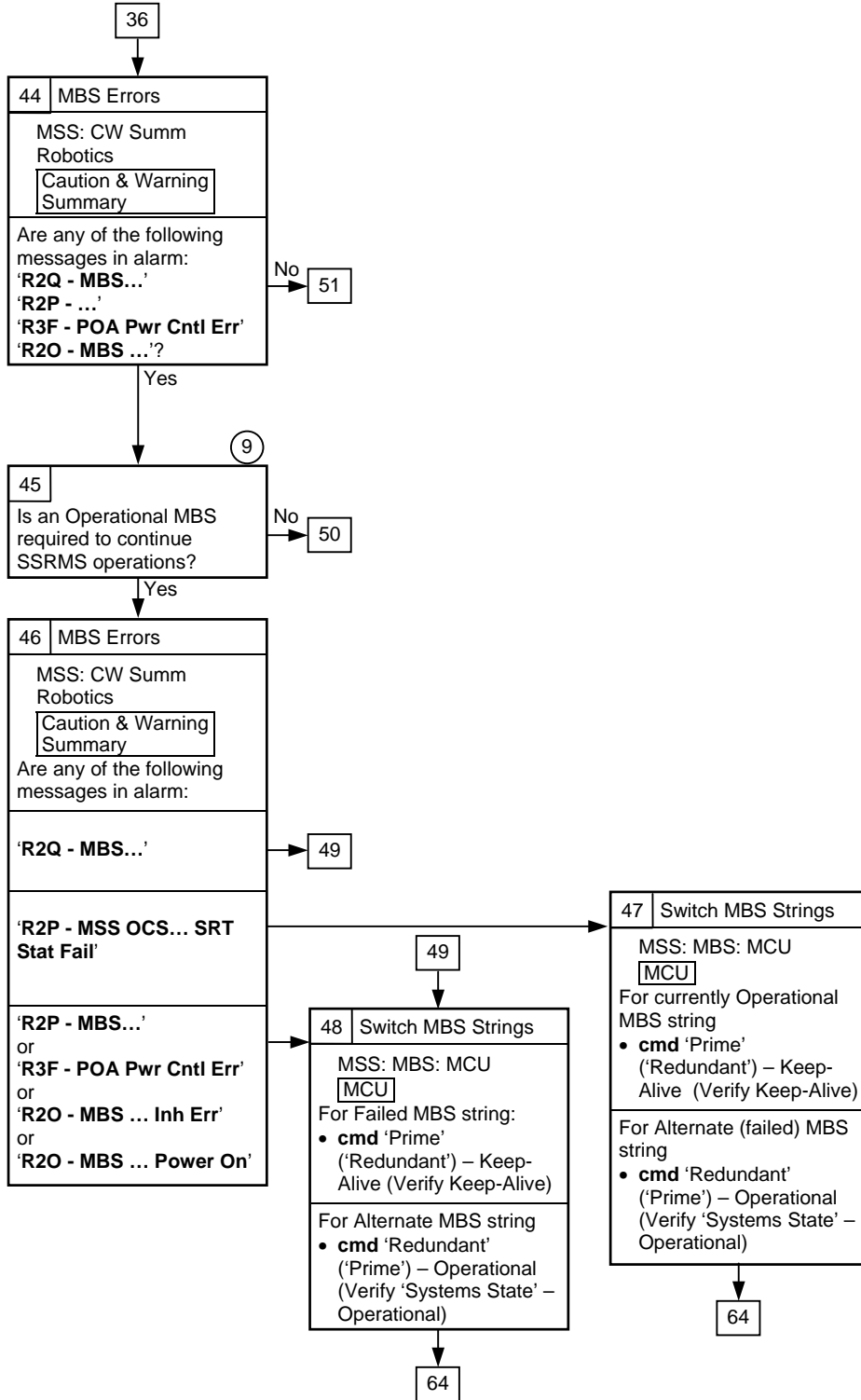

9 An operational MBS is required to power the MBS Mast Camera and light, as well as route/deroute its view. An operational MBS is not required to control pan/tilt/zoom/focus if the camera has already been routed.

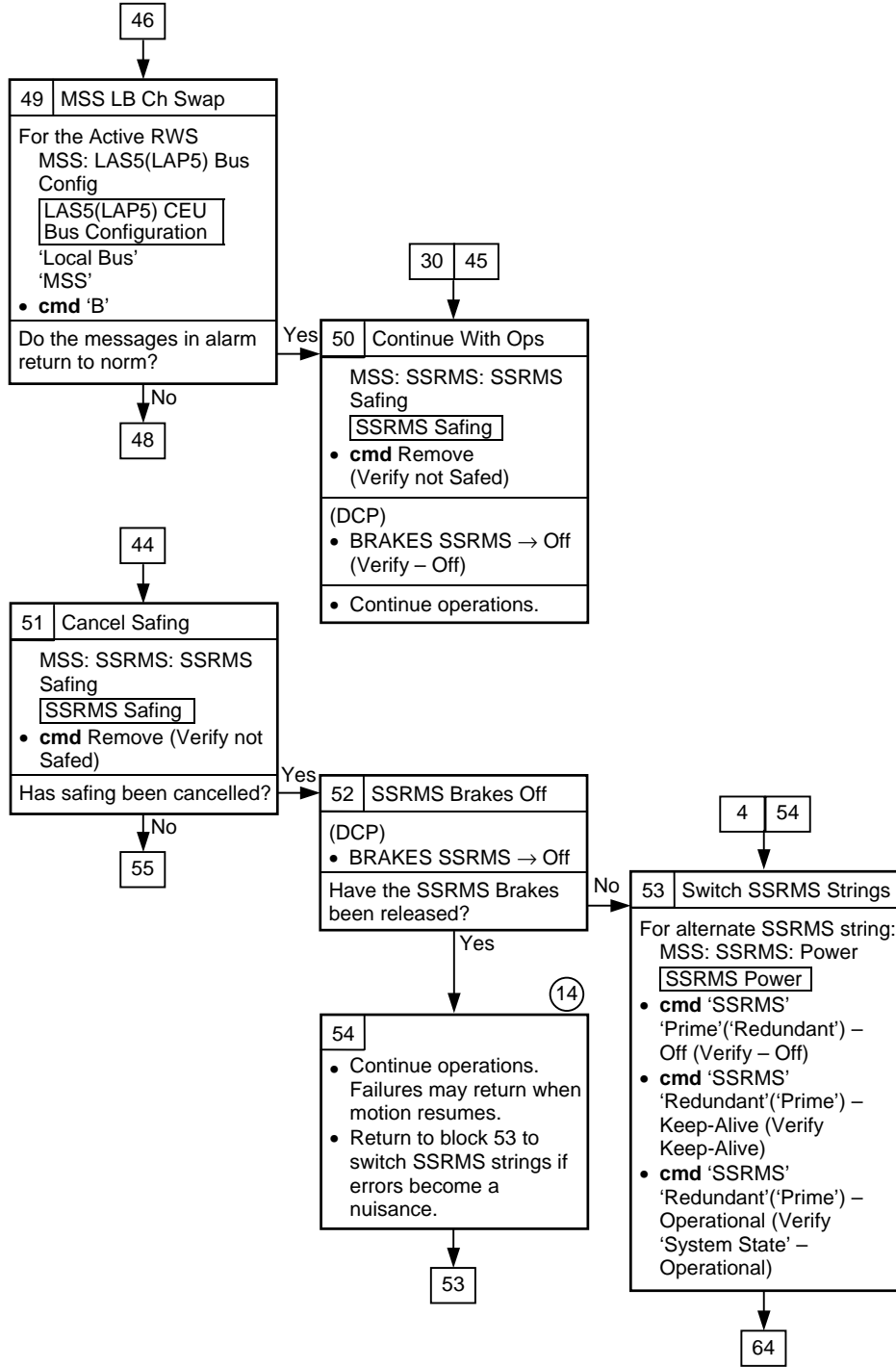

14
 If 'R3H - SSRMS Mtr Current Consistency Ck Fail' errors recur, changing the SSRMS rate setting on the RHC may reduce the likelihood of recurrence.

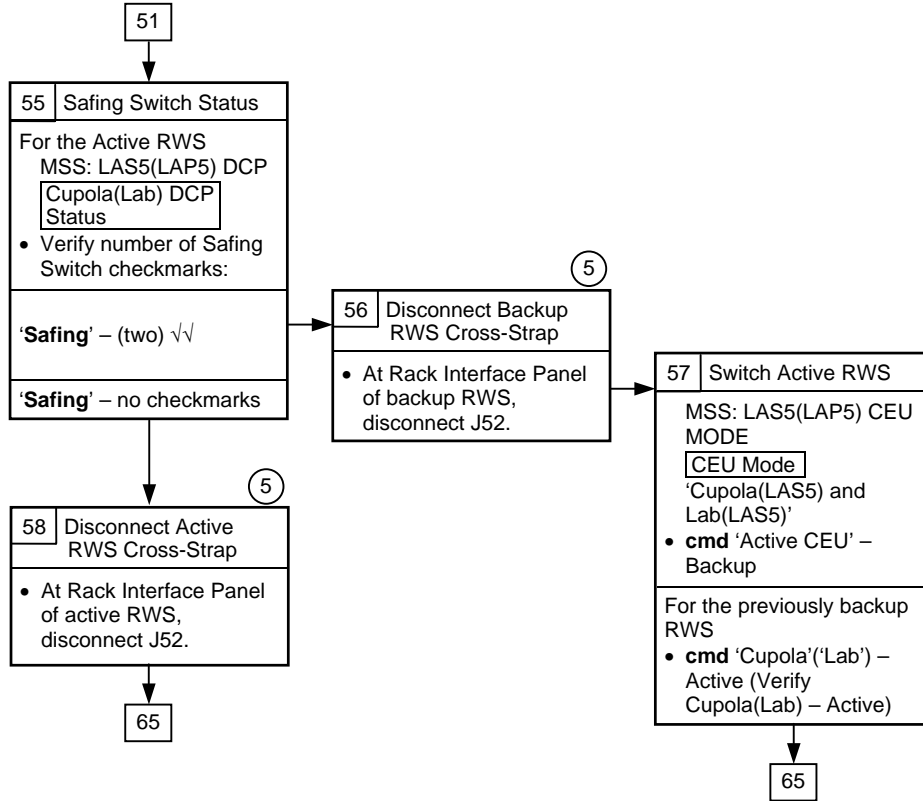

⑤ Cross-strap disconnect inhibits ability of backup RWS to safe system via backup RWS safing switch. E-stop still functional at failed RWS.

36

59 Switch SSRMS Strings

MSS: SSRMS: Power
SSRMS Power

For the failed SSRMS string

- cmd 'SSRMS' 'Prime'('Redundant') – Off (Verify – Off)

For the Alt SSRMS string

- cmd 'SSRMS' 'Redundant'('Prime') – Keep-Alive (Verify Keep-Alive)
- cmd 'SSRMS' 'Redundant'('Prime') – Operational (Verify 'System State' – Operational)

MSS: SSRMS: Base LEE VDU Icon
MSS VDUs

- Power up SSRMS VDUs, as required.

MSS: SSRMS: Base Elbow Camera Icon
Base Elbow Camera

- Power up SSRMS cameras, as required.
- cmd Color Bal – Metal on powered cameras

MSS: Video: Video Overview
Video Overview

- Repeat for all destinations to which an SSRMS Camera is routed
- sel 'Destination icon'
- cmd 'Deroute Video Signal' – Deroute

60

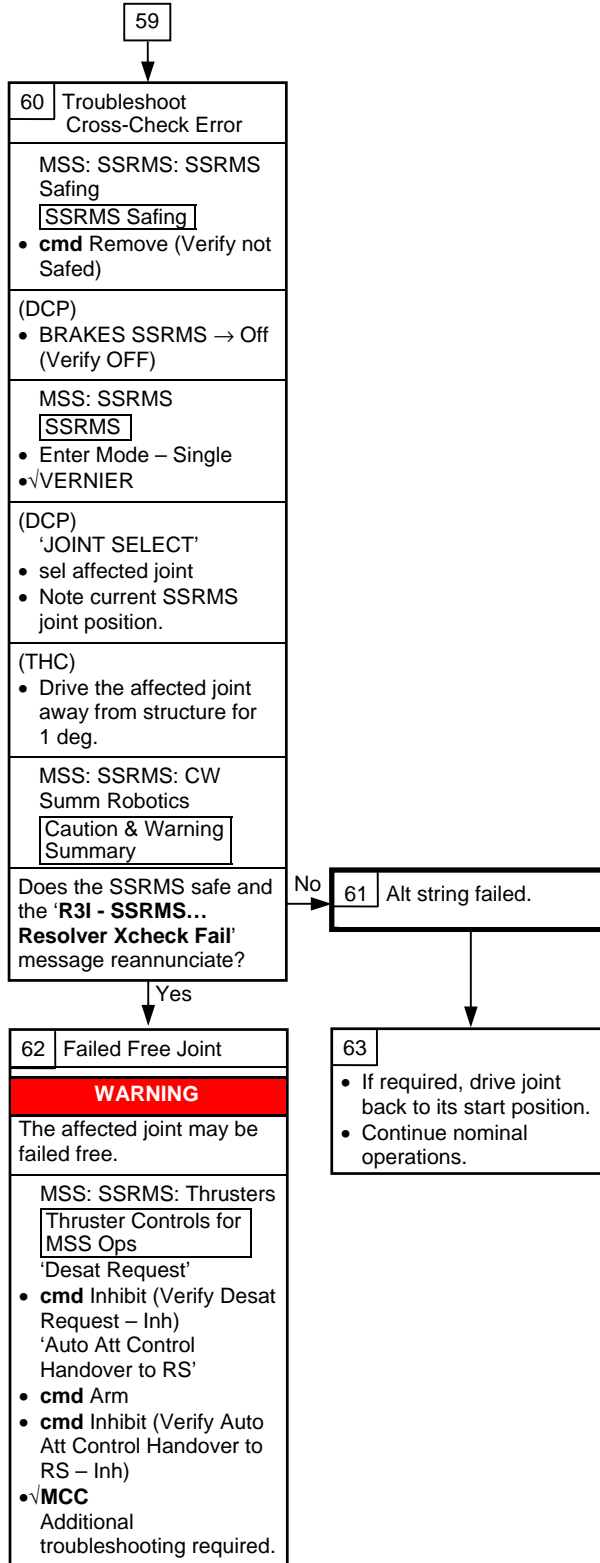

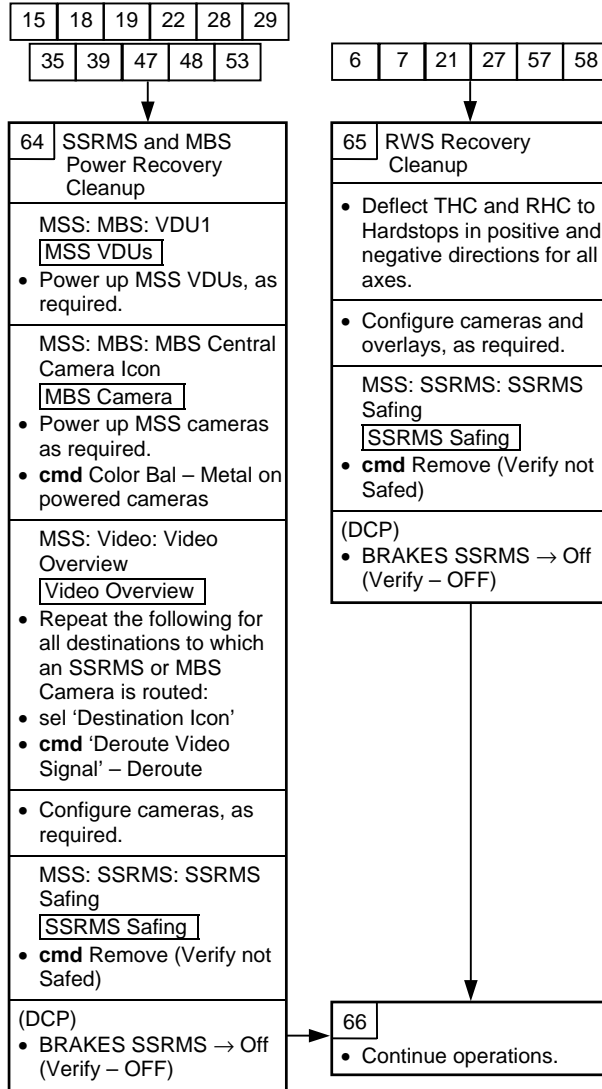

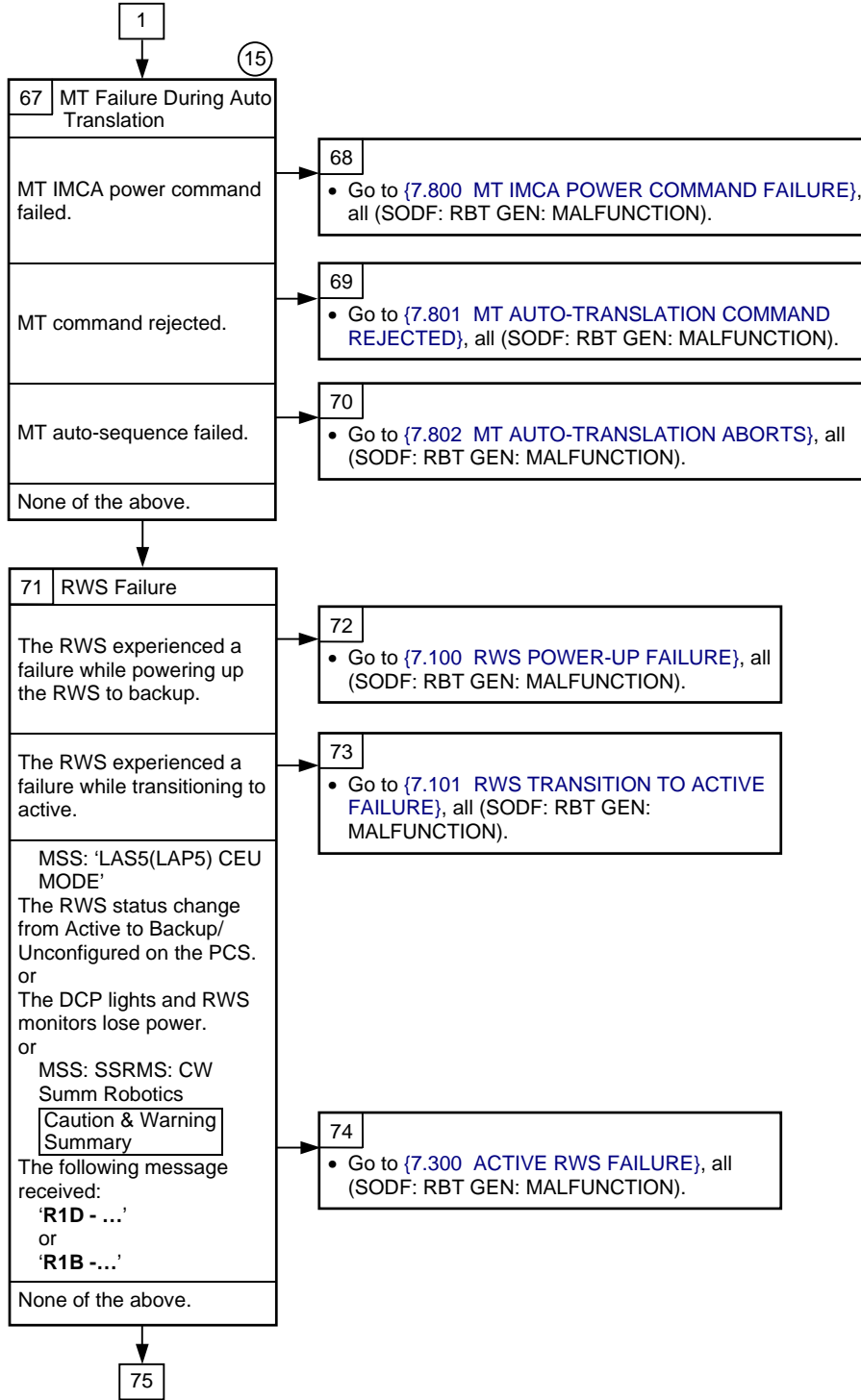

15
 Non time-critical recovery is lead by **MCC-H**. √**MCC-H** before executing procedures

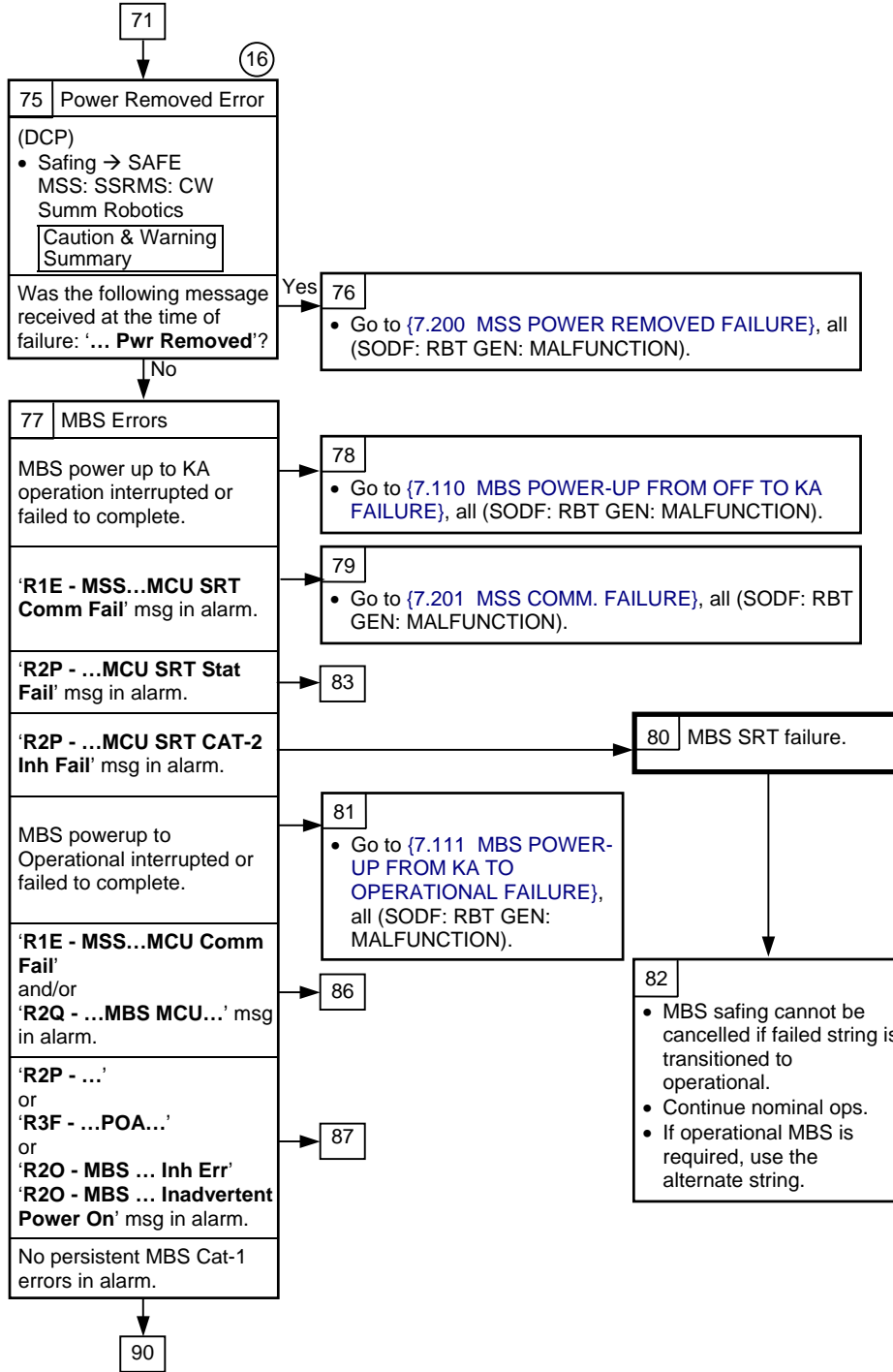

16 SSRMS safing can be cancelled and SSRMS recovery operations can resume in the presence of an MBS CAT-1 error. SCR 22615, 23233, 21737, 19378

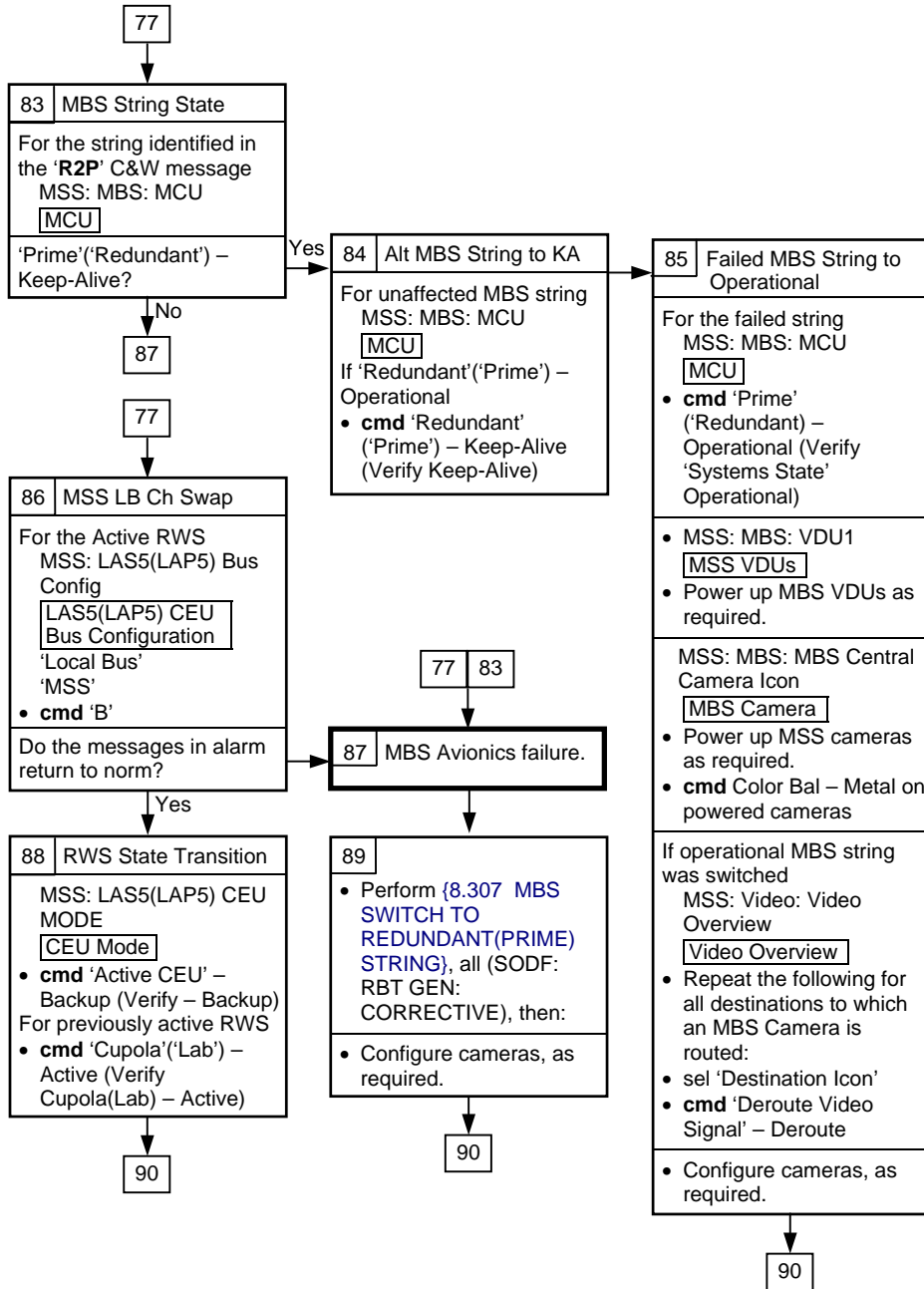

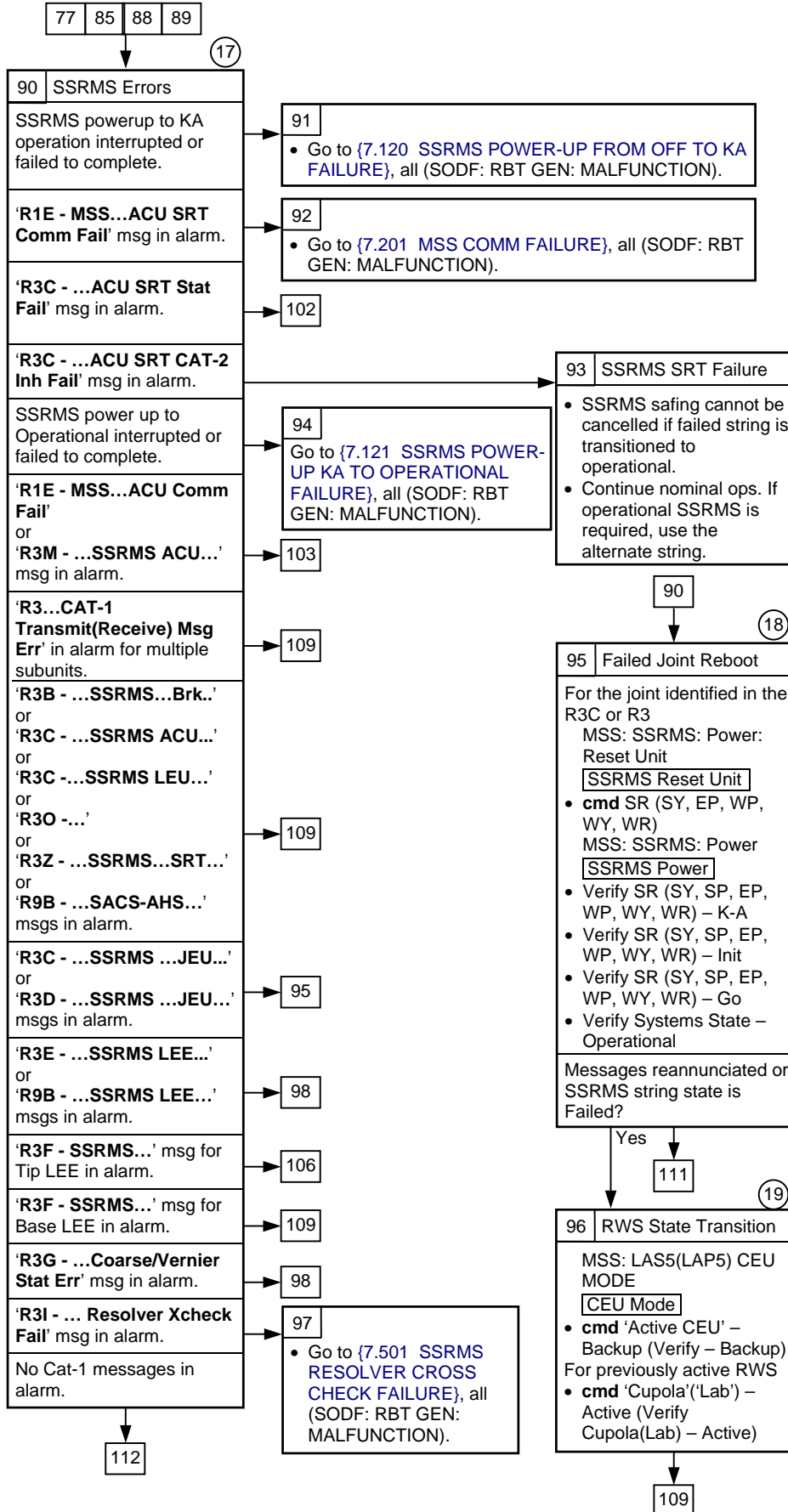

17
If SSRMS is based on end A, Tip LEE is LEU2.
If SSRMS is based on end B, Tip LEE is LEU1.

18
If joint has previously failed on, reboot entire string per {8.106 SSRMS REBOOT PRIME (REDUNDANT) STRING}, all (SODF: RBT: GEN: CORRECTIVE).

19
SCR 28722

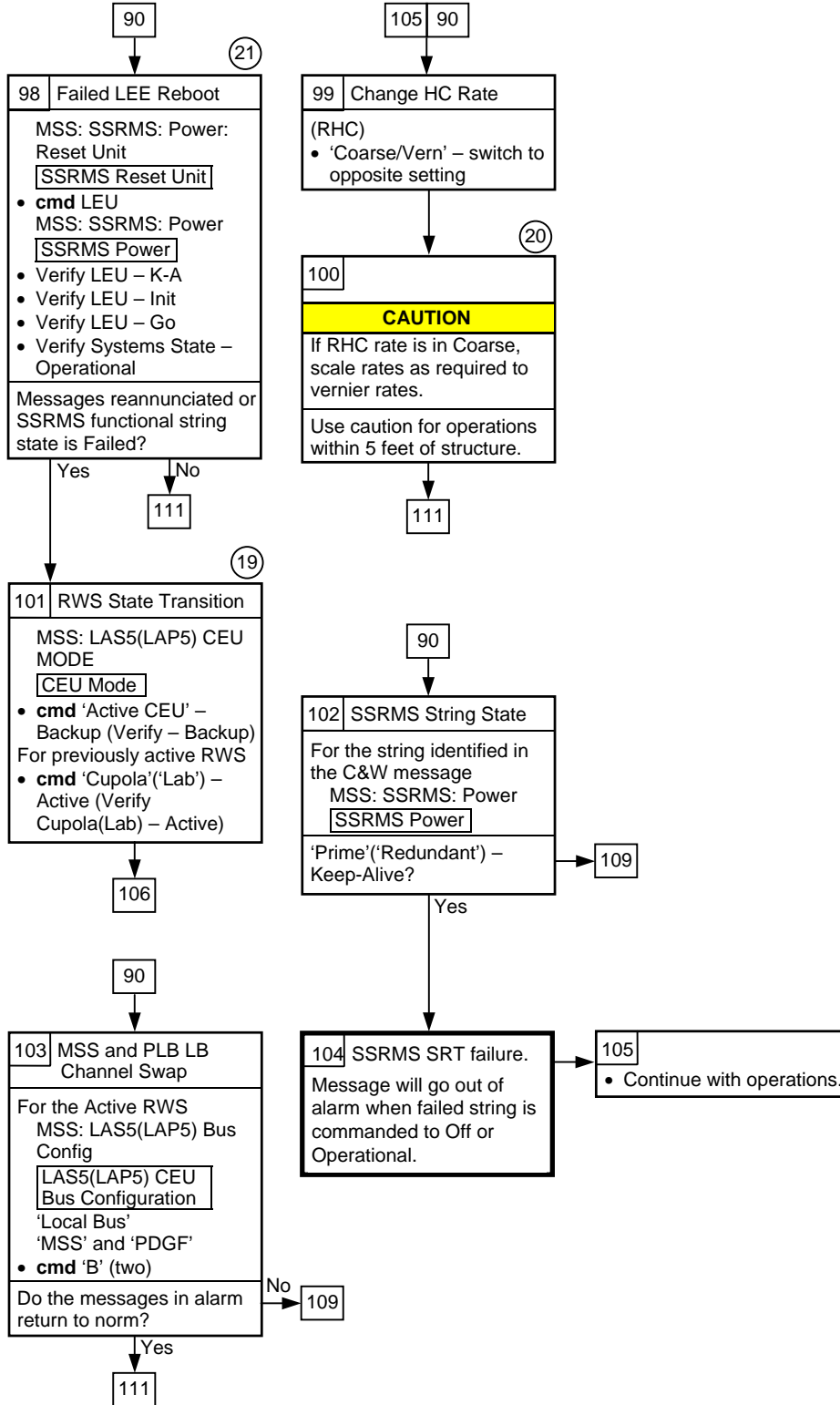

(19) SCR 28722

(20) If failure is 'R3G - SSRMS ACU Coarse/Vernier Stat ERR' and RHC rate is in coarse, MSS powerdown or RWS state transition removes string functionality.

(21) If LEE has previously failed on, reboot entire string per (8.106 SSRMS REBOOT PRIME (REDUNDANT) STRING), all (SODF: RBT: GEN: CORRECTIVE).

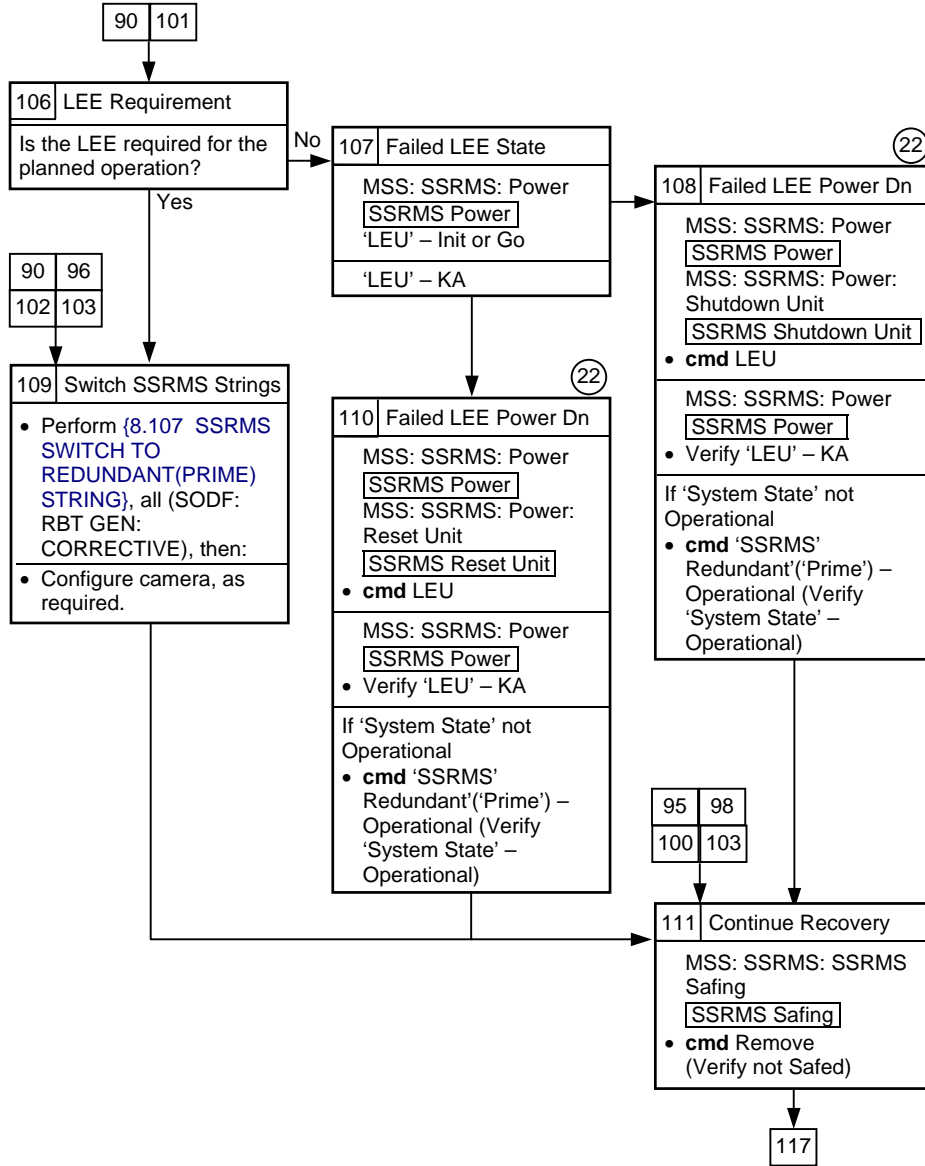

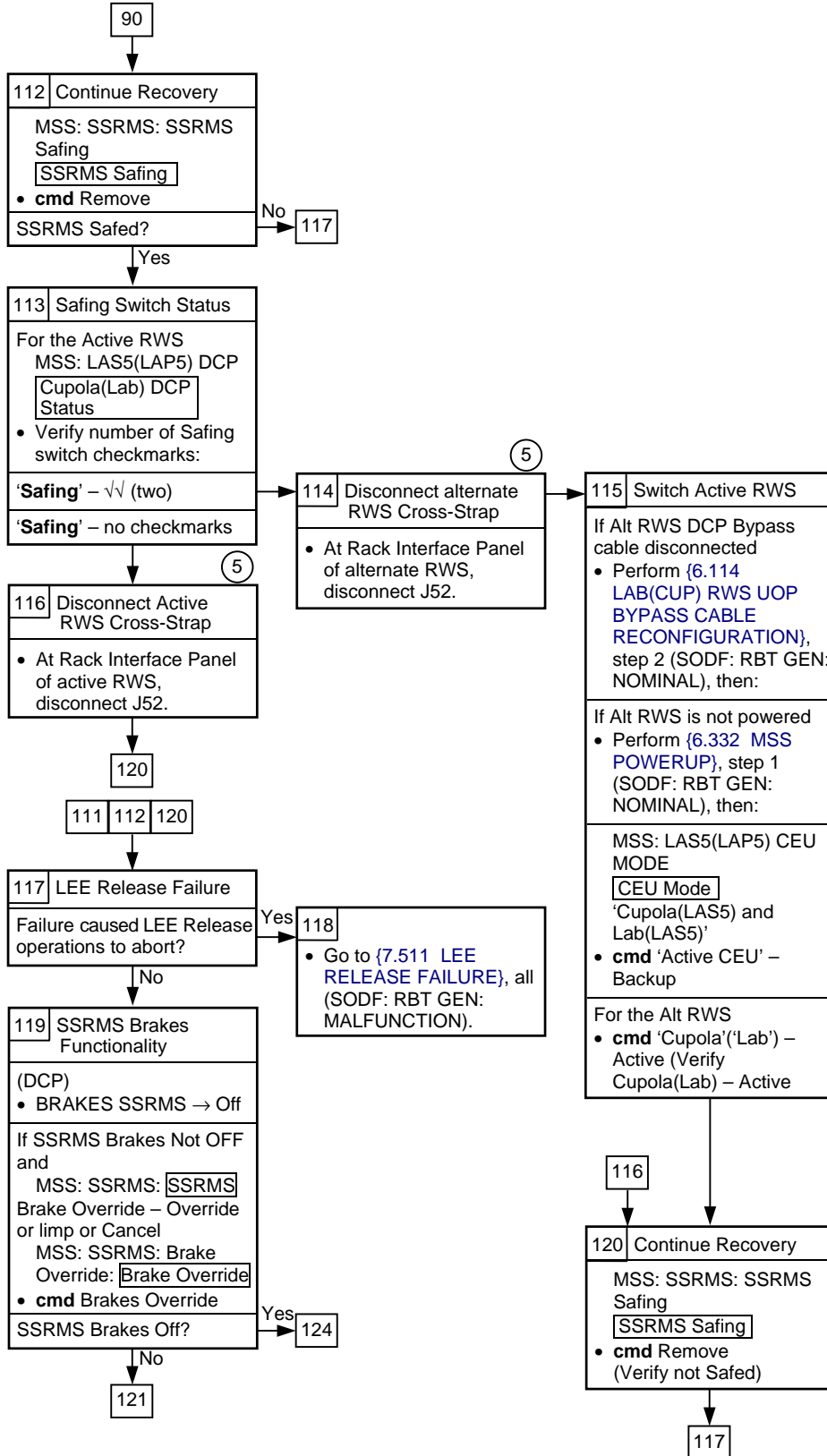

5
 Cross-strap disconnect inhibits ability of backup RWS to safe system via backup RWS safing switch. E-stop still functional at failed RWS.

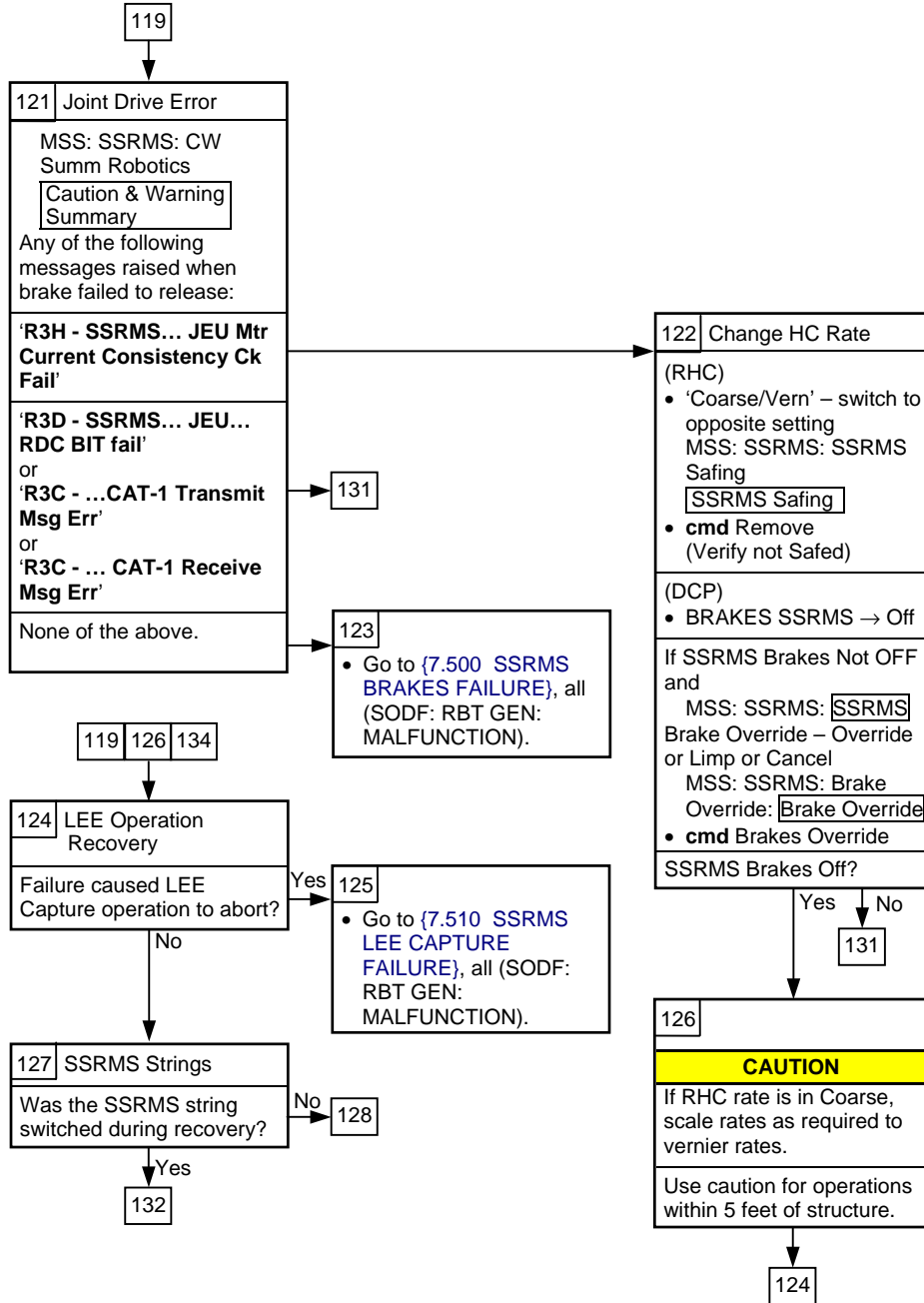

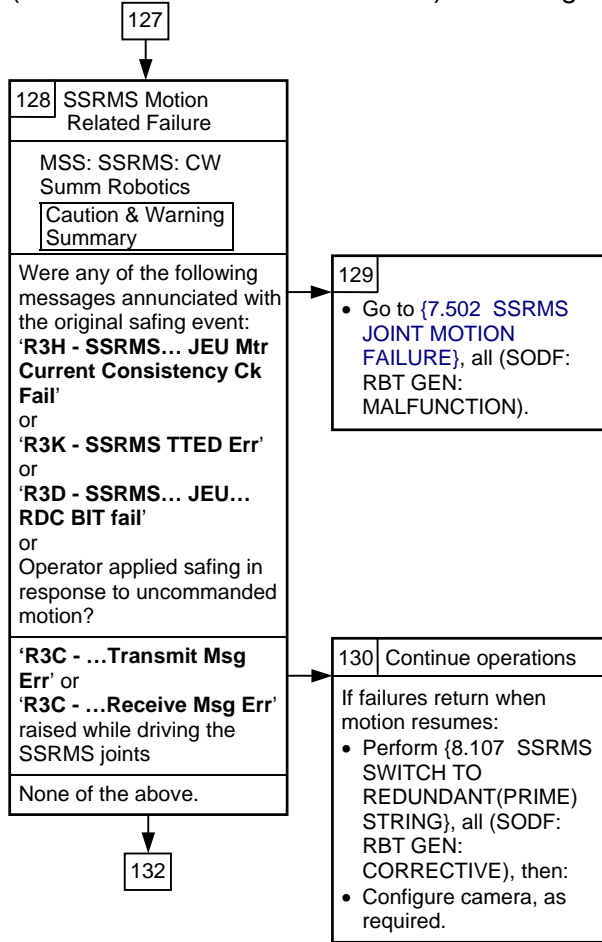

7.001 MSS FAILURE RESPONSE AND RECOVERY

(RBT GEN/X2R4 - ALL/FIN/SPN)

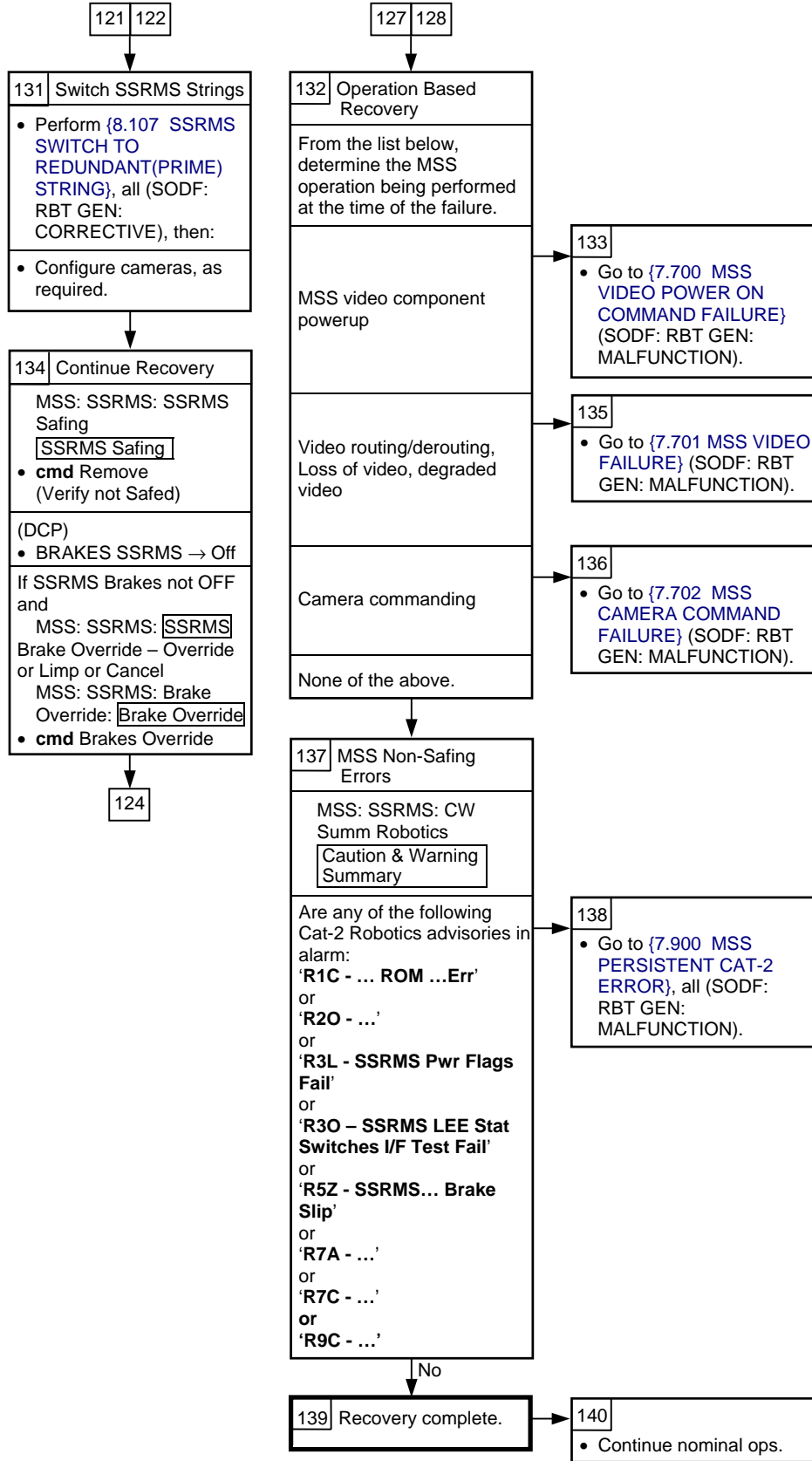

MSS

C&W
ROBOTICS

7.100 RWS POWER-UP FAILURE

(RBT GEN/X2R4 - ALL/FIN)

Page 1 of 12 pages

Robotics
Workstation
Failure While
Performing Step
1 of 6.332 MSS
Powerup or Step
2 of 6.114
LAB(CUP) RWS
UOP Bypass
Cable
Reconfiguration

Nominal Config:
The DCP lighting
switch is not in the
OFF position.

The monitor
brightness setting is
not fully dimmed.

PMCU MDM
configured for
SEPS control.

Test Pattern routed to
all monitors on
affected RWS.

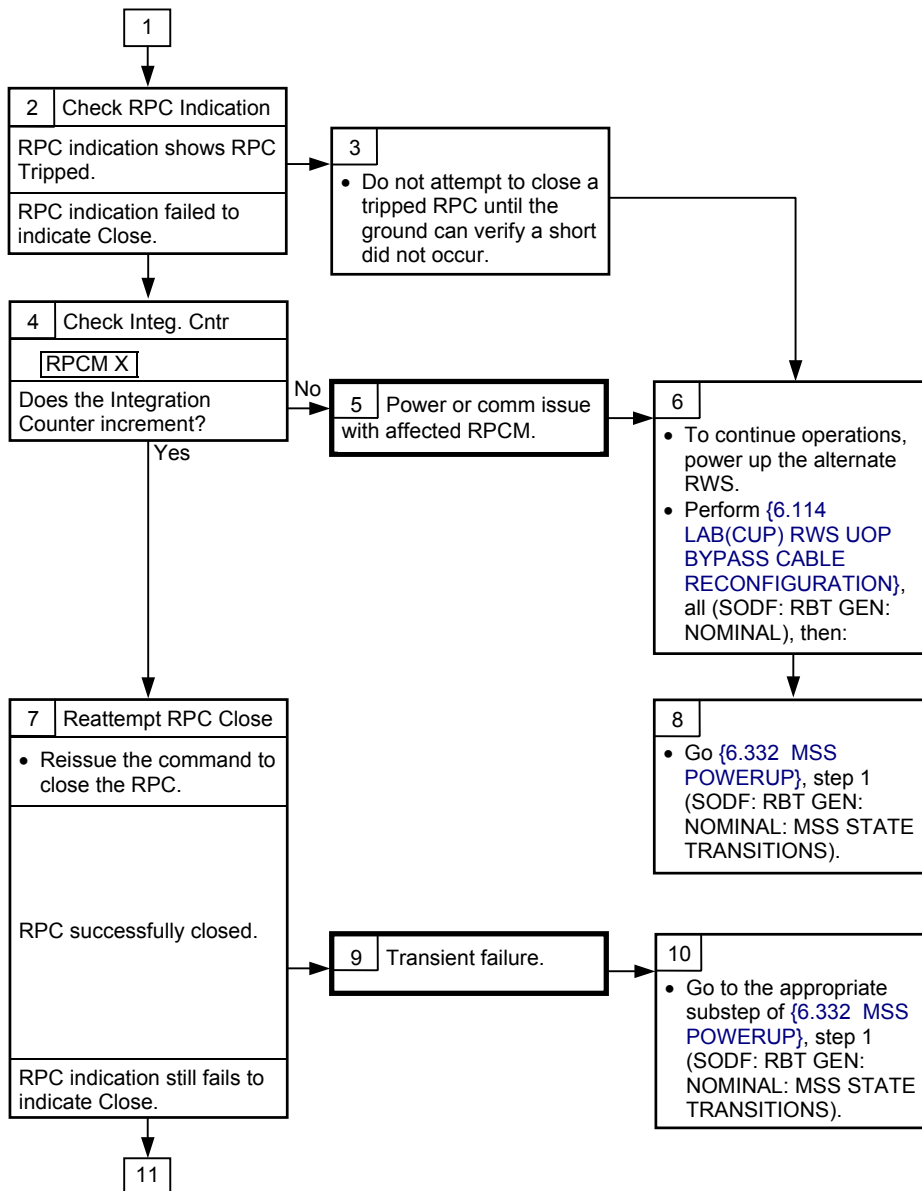
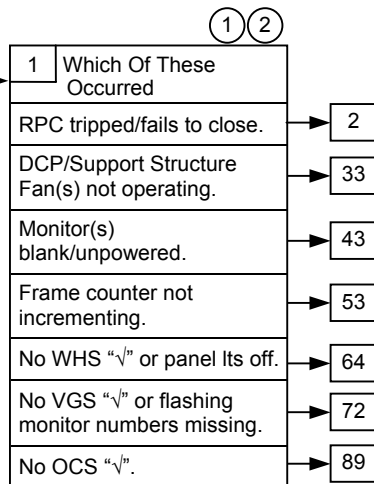

①
{7.001 MSS FAILURE RESPONSE AND RECOVERY}, block 72 (SODF: RBT GEN: MALFUNCTION)

②
Unless otherwise indicated, all displays in this procedure are on the PCS.

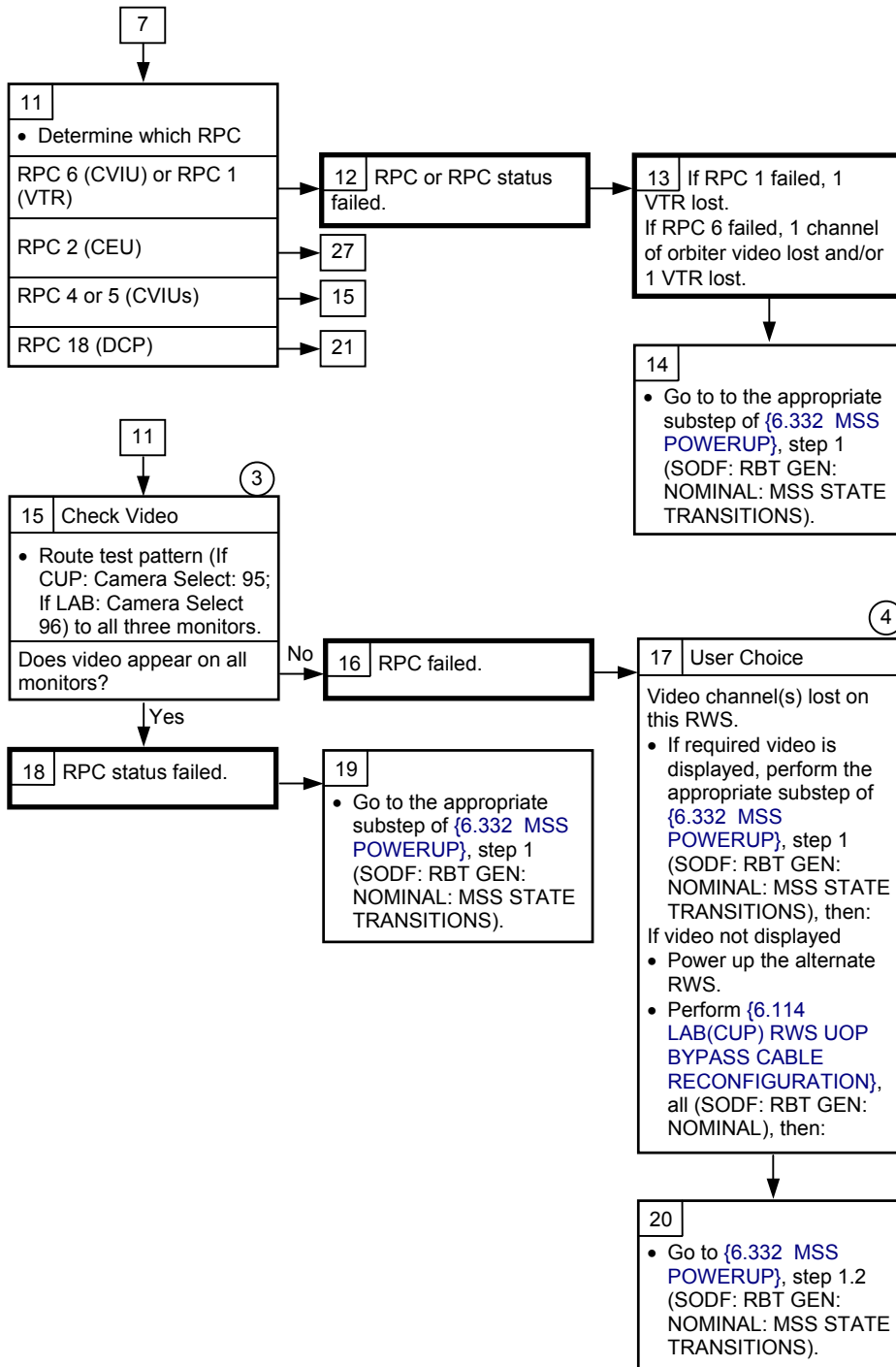

③ This step can only be performed by onboard crew.

④ Ground will perform required steps for powerdown/cleanup.

7.100 RWS POWER-UP FAILURE

(RBT GEN/X2R4 - ALL/FIN)

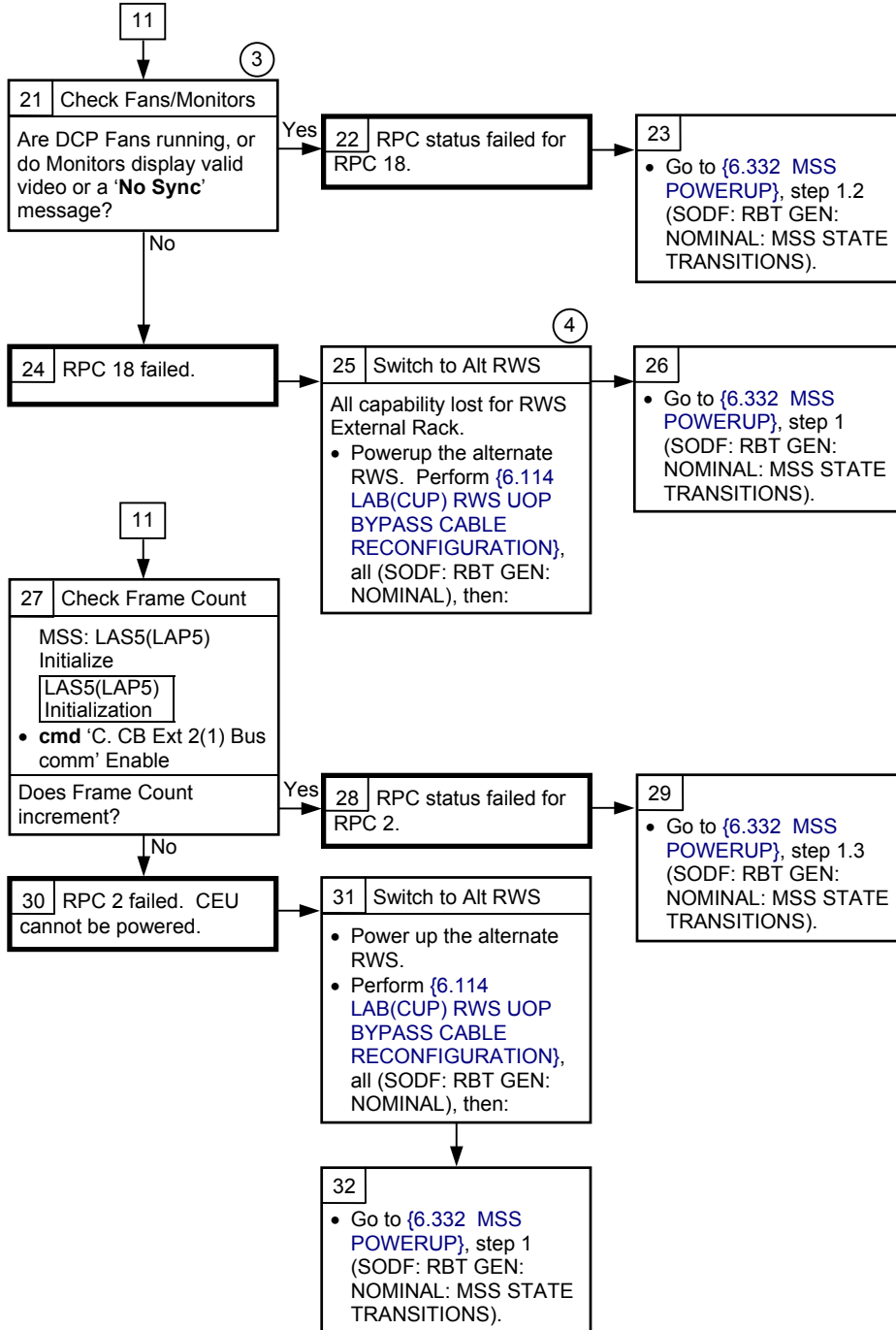

3 This step can only be performed by onboard crew.

4 Ground will perform required steps for powerdown/cleanup.

7.100 RWS POWER-UP FAILURE

(RBT GEN/X2R4 - ALL/FIN)

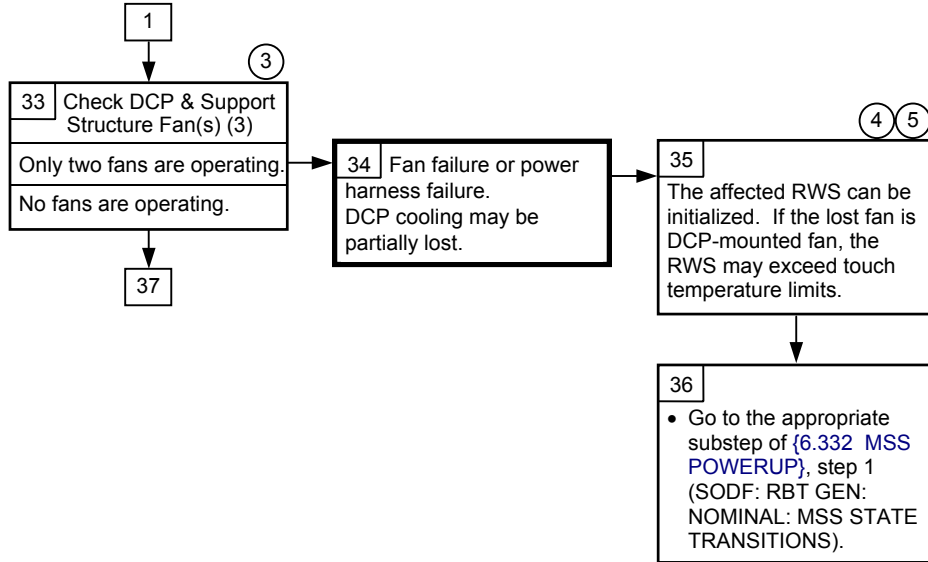

3 This step can only be performed by onboard crew.

4 DCP touch temperature violation may occur. Analysis shows a potential overtemp of 2.6 deg with one fan failed.

5 The fan mounted underneath the PCS can be swapped out with a failed DCP fan to recover full DCP cooling.

33

③

37	Powercycle DCP
<ul style="list-style-type: none"> Prior to RPC opening, check if DCP Monitors are powered. 	
MSS: 'RPCM LAS5(LAP5)' 18 [RPCM_LAS52A3B_A_RPC_18 (RPCM_LAP51A4A_A_RPC_18)]	
<ul style="list-style-type: none"> cmd 'RPC Position' – Open (Verify – Op) 	
If monitors were unpowered prior to RPC opening	
<ul style="list-style-type: none"> cmd 'Close Cmd' – Inhibit (Verify – Inh) Check DCP J1, DCP J6, and UOP bypass cable connections (reference Figure 1), then: cmd 'Close Cmd' – Enable (Verify – Ena) cmd 'RPC Position' – Close (Verify – Cl) 	

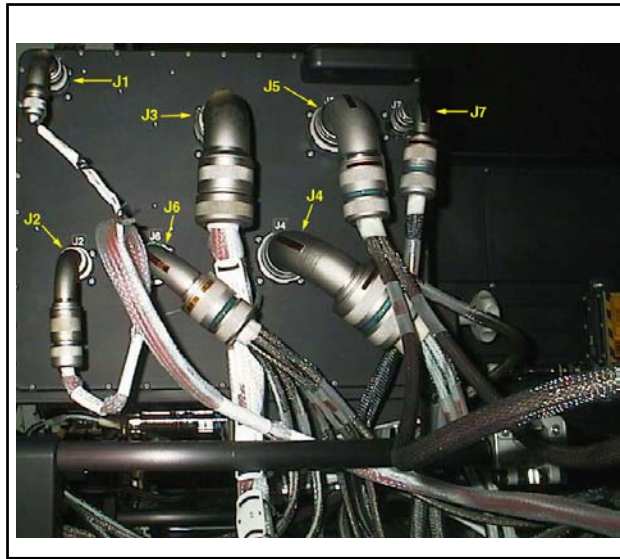
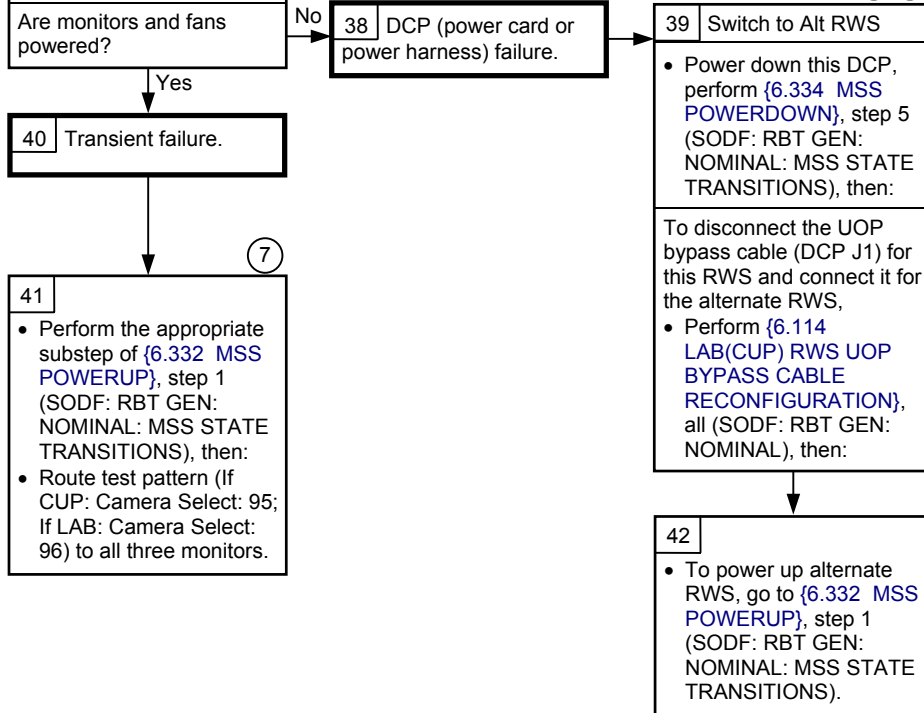

Figure 1. DCP Cables.



③ This step can only be performed by onboard crew.

⑥ If monitors are powered, the affected RWS can be initialized, but the DCP will overheat.

⑦ Reroute video if necessary to clean up monitor view.

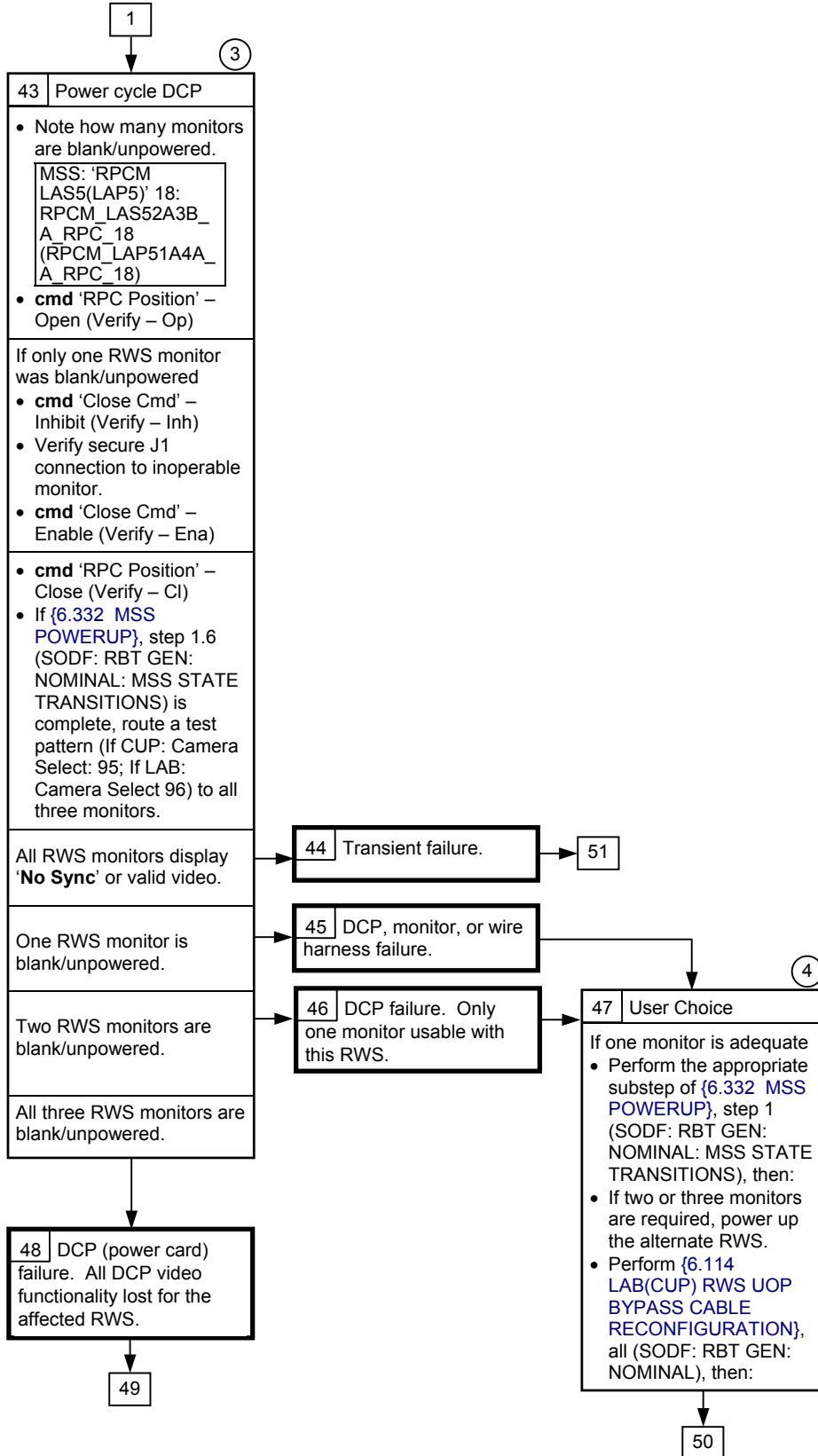

3 This step can only be performed by onboard crew.

4 Ground will perform required steps for powerdown/cleanup.

7.100 RWS POWER-UP FAILURE

(RBT GEN/X2R4 - ALL/FIN)

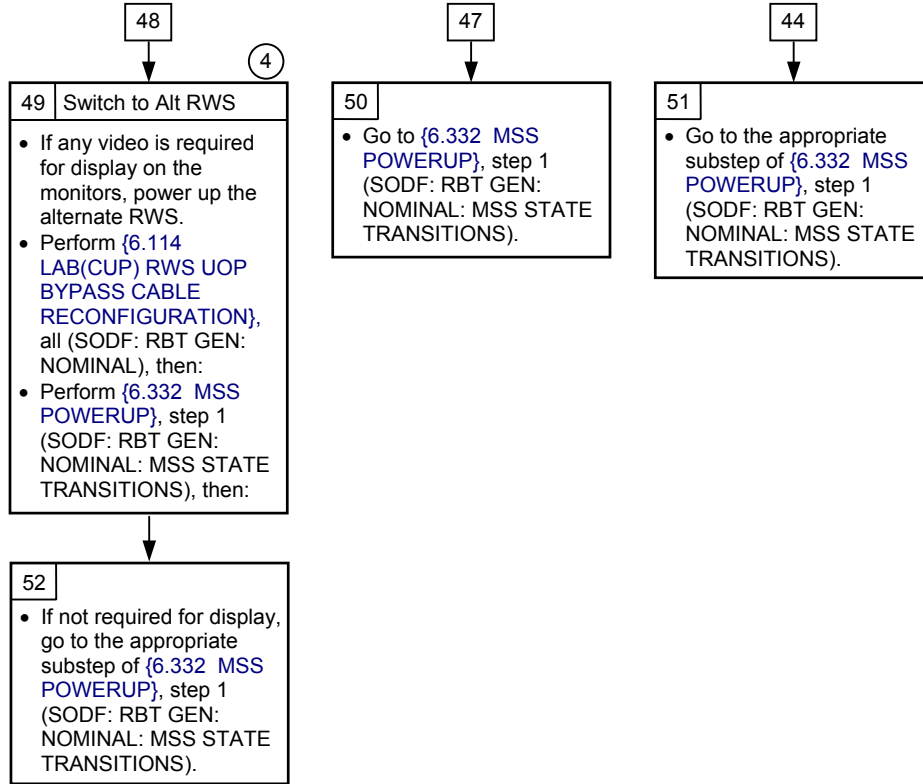

4 Ground will perform required steps for powerdown/cleanup.

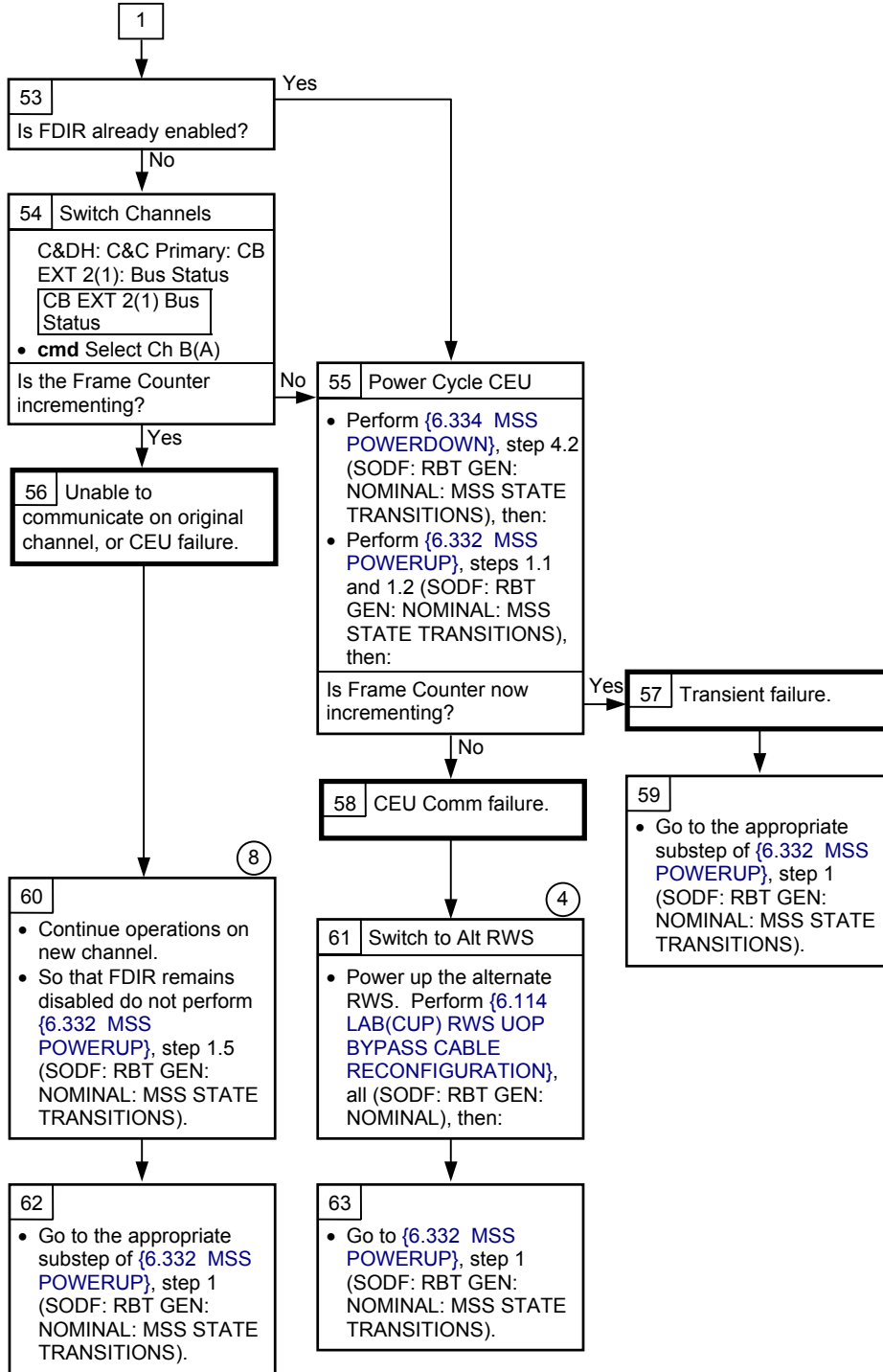

4 Ground will perform required steps for powerdown/cleanup.

8 A comm failure in any of the other RT's on CB-EXT1(2) may cause the C&C to swap back to the channel on which the CEU cannot communicate. If that occurs, the ground will determine which of the two failed RTs are required.

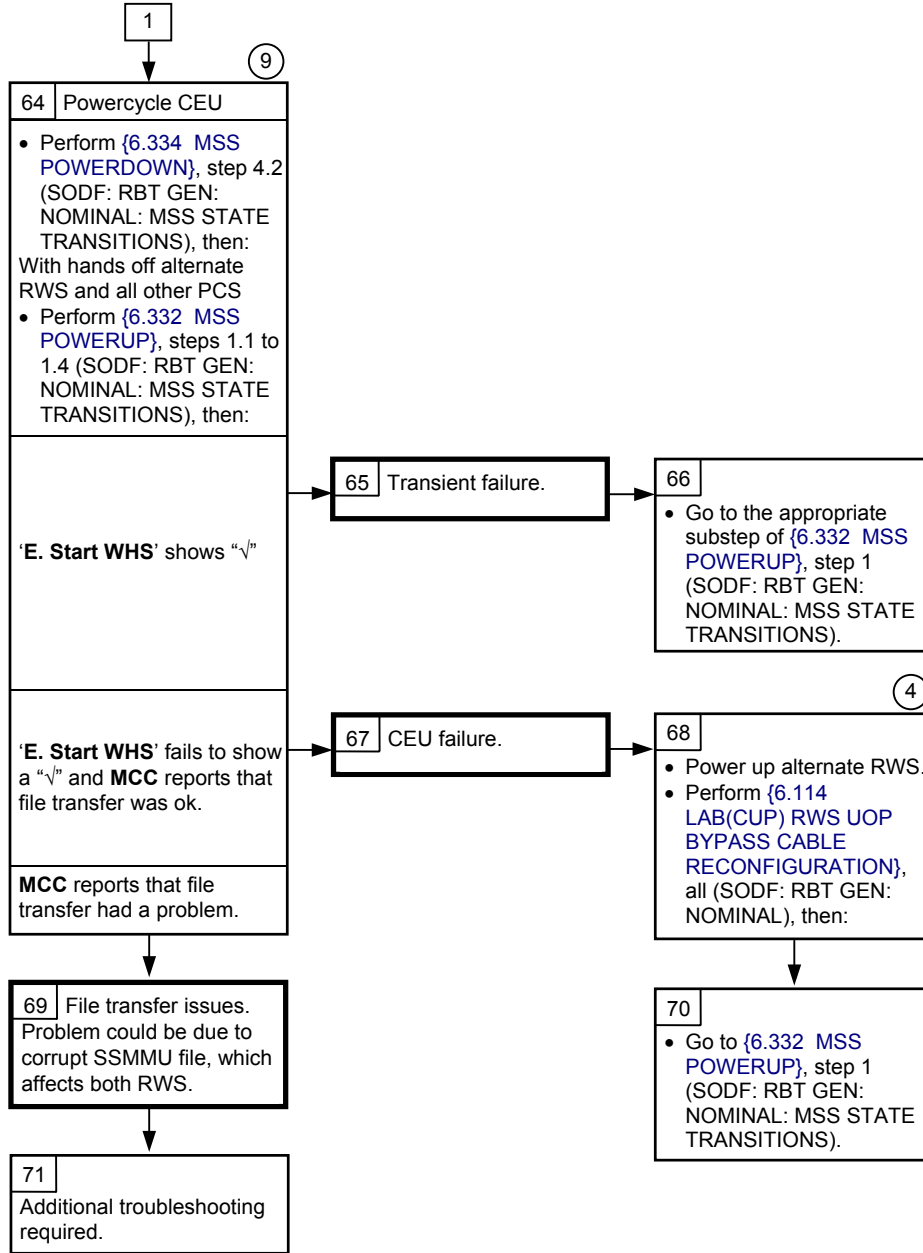

4 Ground will perform required steps for powerdown/cleanup.

9 Ground must verify correct WHS file size and proper completion of file download.

7.100 RWS POWER-UP FAILURE

(RBT GEN/X2R4 - ALL/FIN)

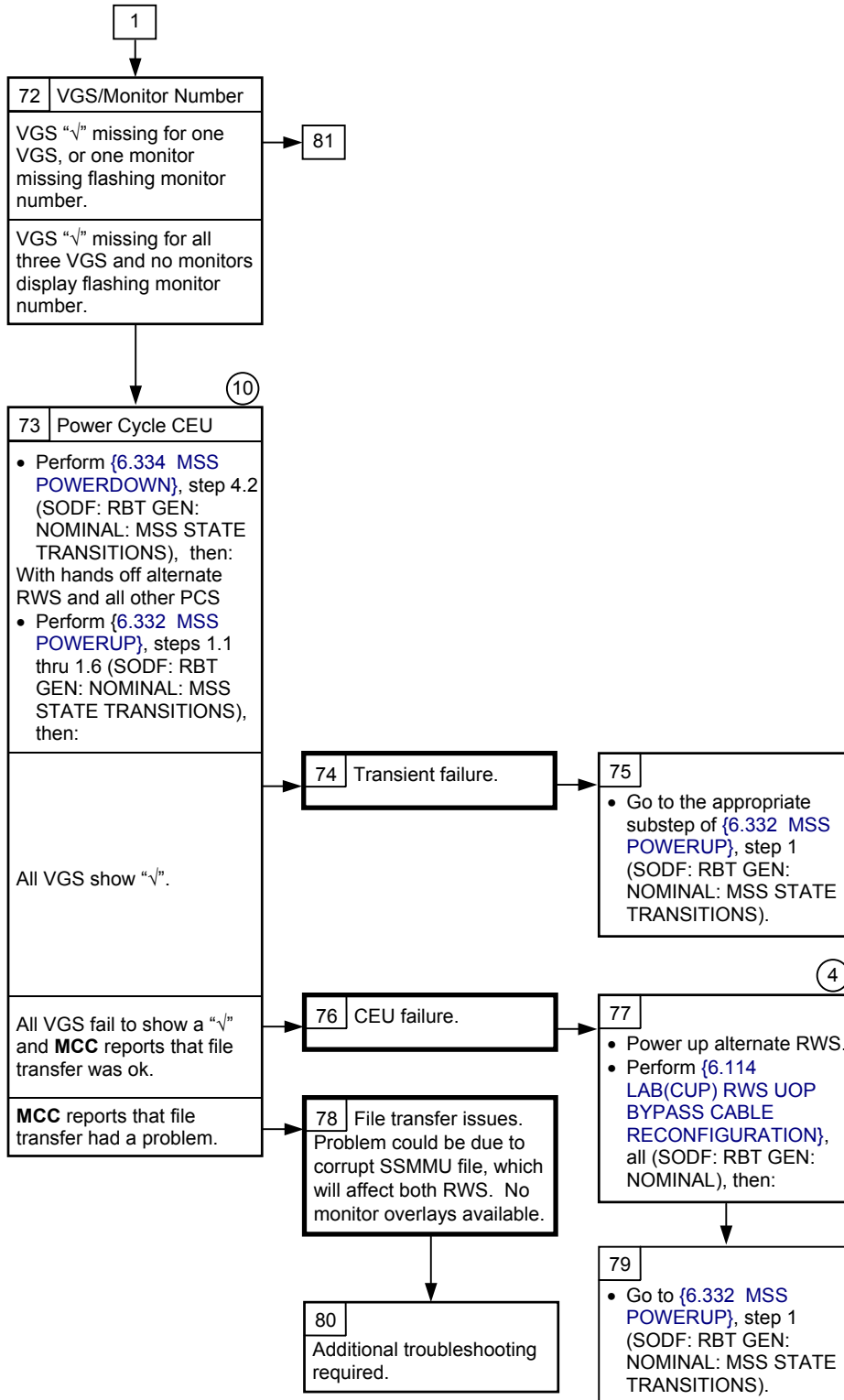

④ Ground will perform required steps for powerdown/cleanup.

⑩ Ground must verify correct VGS file size and proper completion of file download.

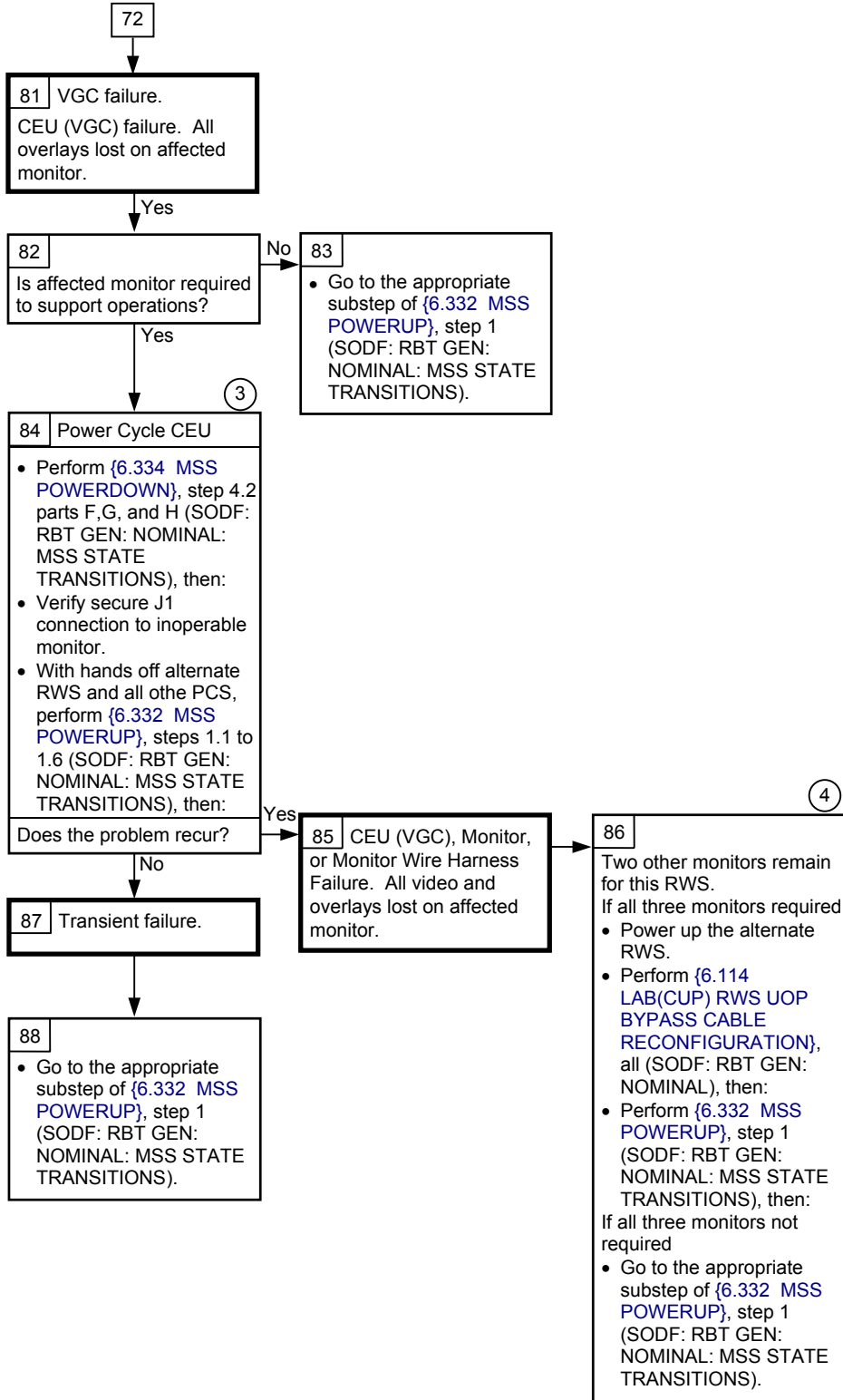

③ This step can only be performed by onboard crew.

④ Ground will perform required steps for powerdown/cleanup.

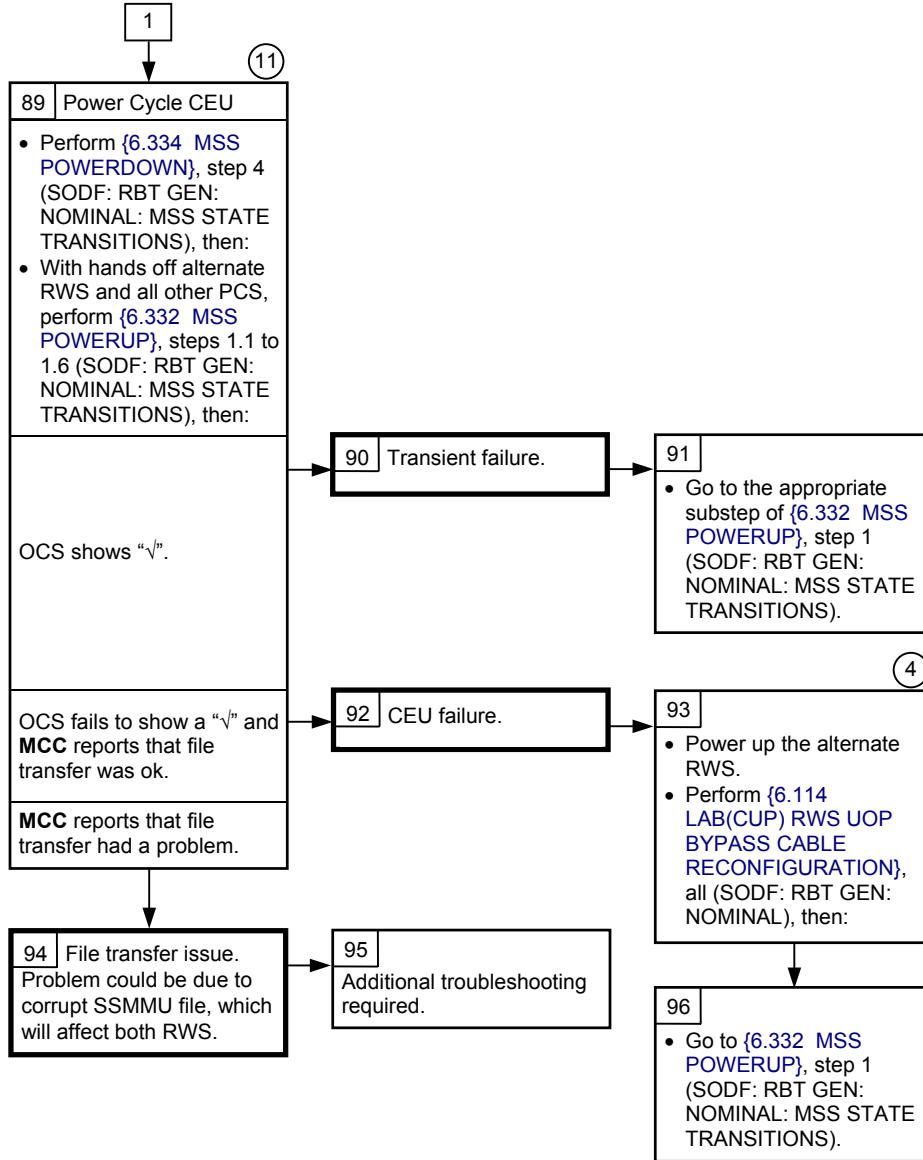

④ Ground will perform required steps for powerdown/cleanup.

⑪ Ground must verify correct OCS file size and proper completion of file download.

MSS

C&W
ROBOTICS

7.120 SSRMS POWER-UP FROM OFF TO KA FAILURE

(RBT GEN/X2R4 - ALL/FIN) Page 1 of 6 pages

C&W messages Starting With 'Rxx - ...'

SSRMS Power Up From Off to Keep-Alive Fails

Nominal Config:
If SSRMS is based on MBS, MBS powered on both strings and Operational on one string with no MCU comm.

If SSRMS is based on ISS PDGF, EXT and S0 MDMs configured for SEPS control.

Alternate SSRMS string is not Operational.

RWS is Active.

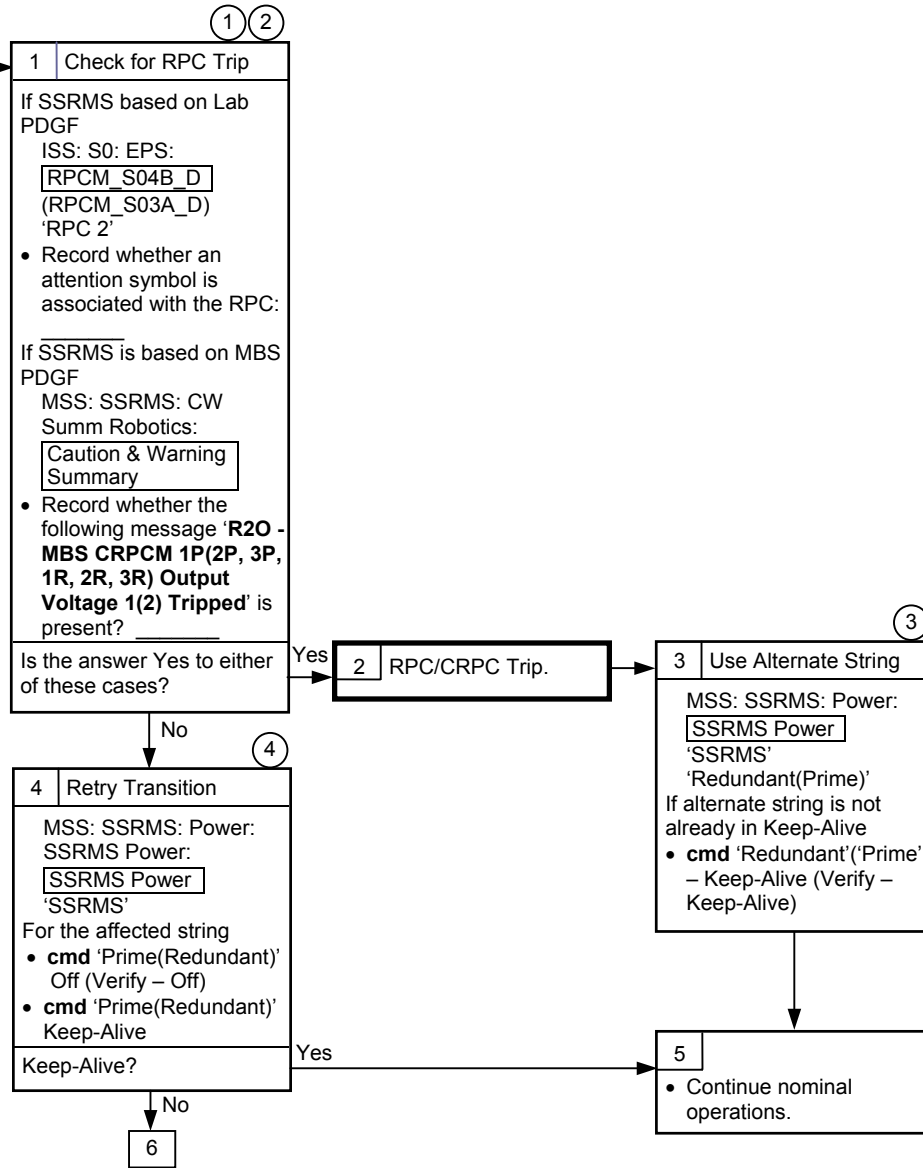

①
{7.001 MSS FAILURE RESPONSE AND RECOVERY}, block 91 (SODF: RBT GEN: MALFUNCTION)

②
Unless otherwise noted, all displays in this procedure are on the PCS.

③
If both SSRMS strings have been powered Off for an extended period of time, refer to Flight Rule B12-104 for applicable warmup times prior to commanding string to Operational.

④
For some failure signatures it is possible that the Off command will be rejected. If the command-rejected message is received, ignore it and press with the transition retry.

7.120 SSRMS POWER-UP FROM OFF TO KA FAILURE

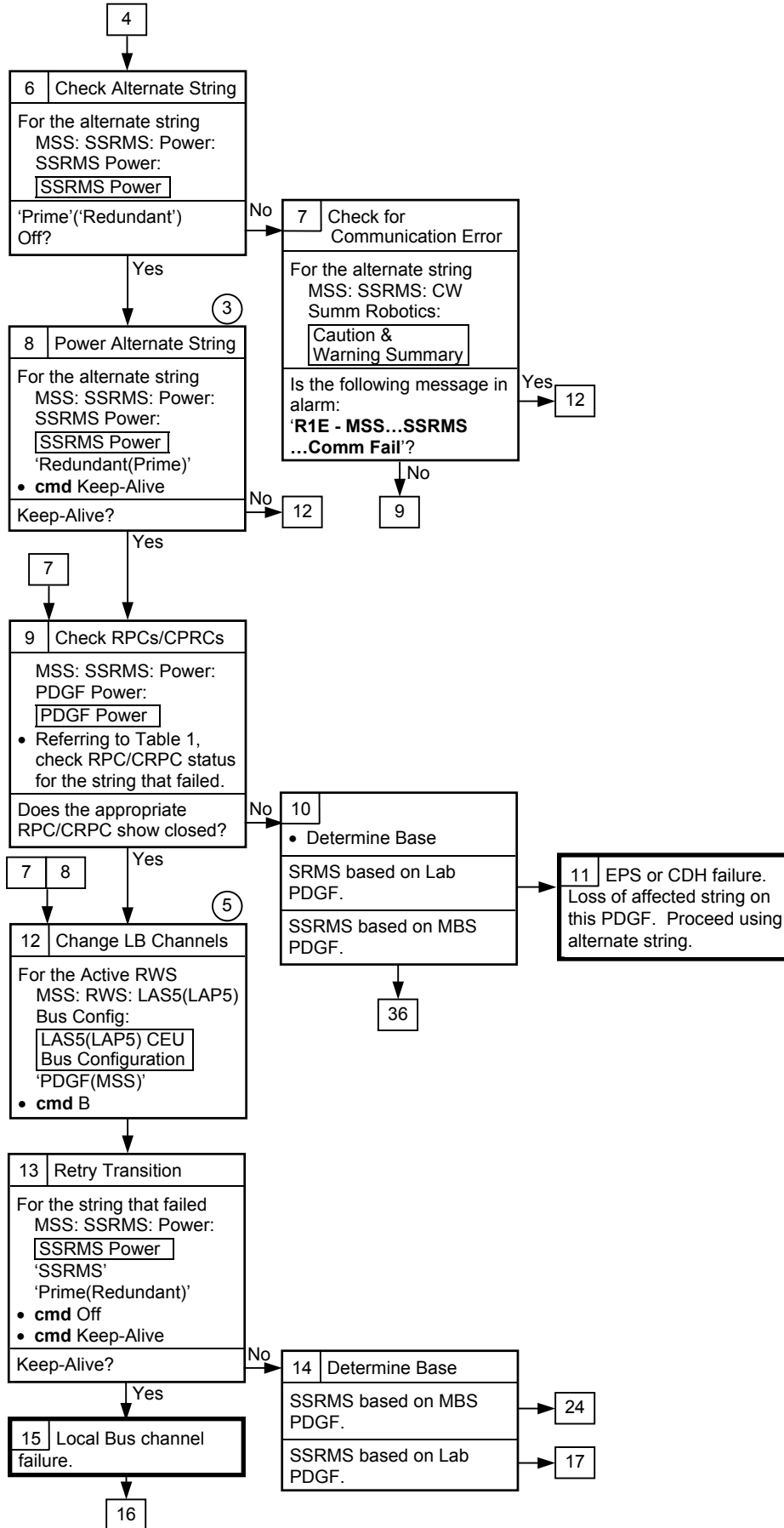

③ If both SSRMS strings have been powered Off for an extended period of time, refer to Flight Rule B12-104 for applicable warmup times prior to commanding string to Operational.

⑤ PDGF LB if SSRMS is based on Lab PDGF, MSS LB if based on MBS PDGF.

7.120 SSRMS POWER-UP FROM OFF TO KA FAILURE

(RBT GEN/X2R4 - ALL/FIN) Page 3 of 6 pages

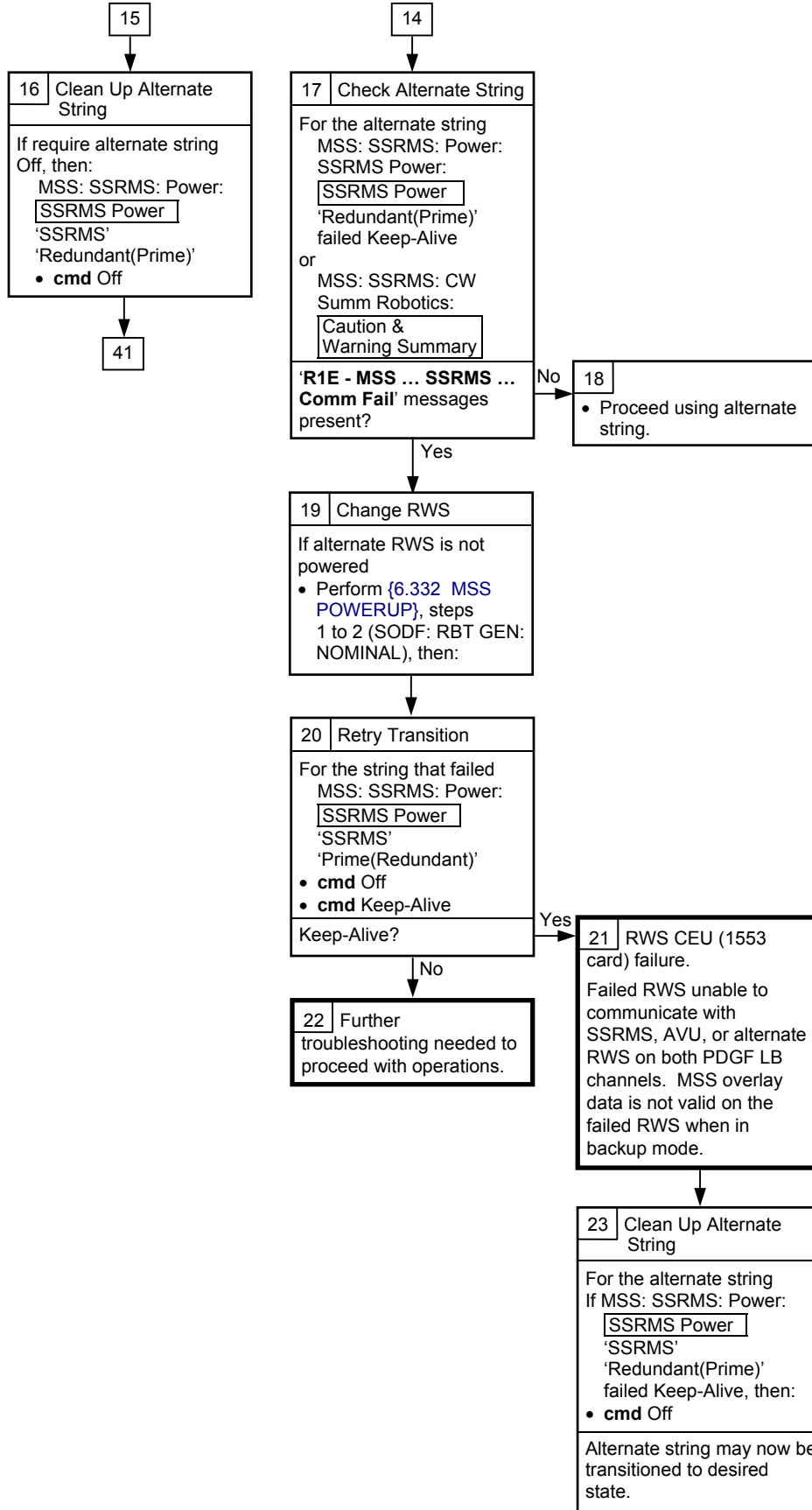

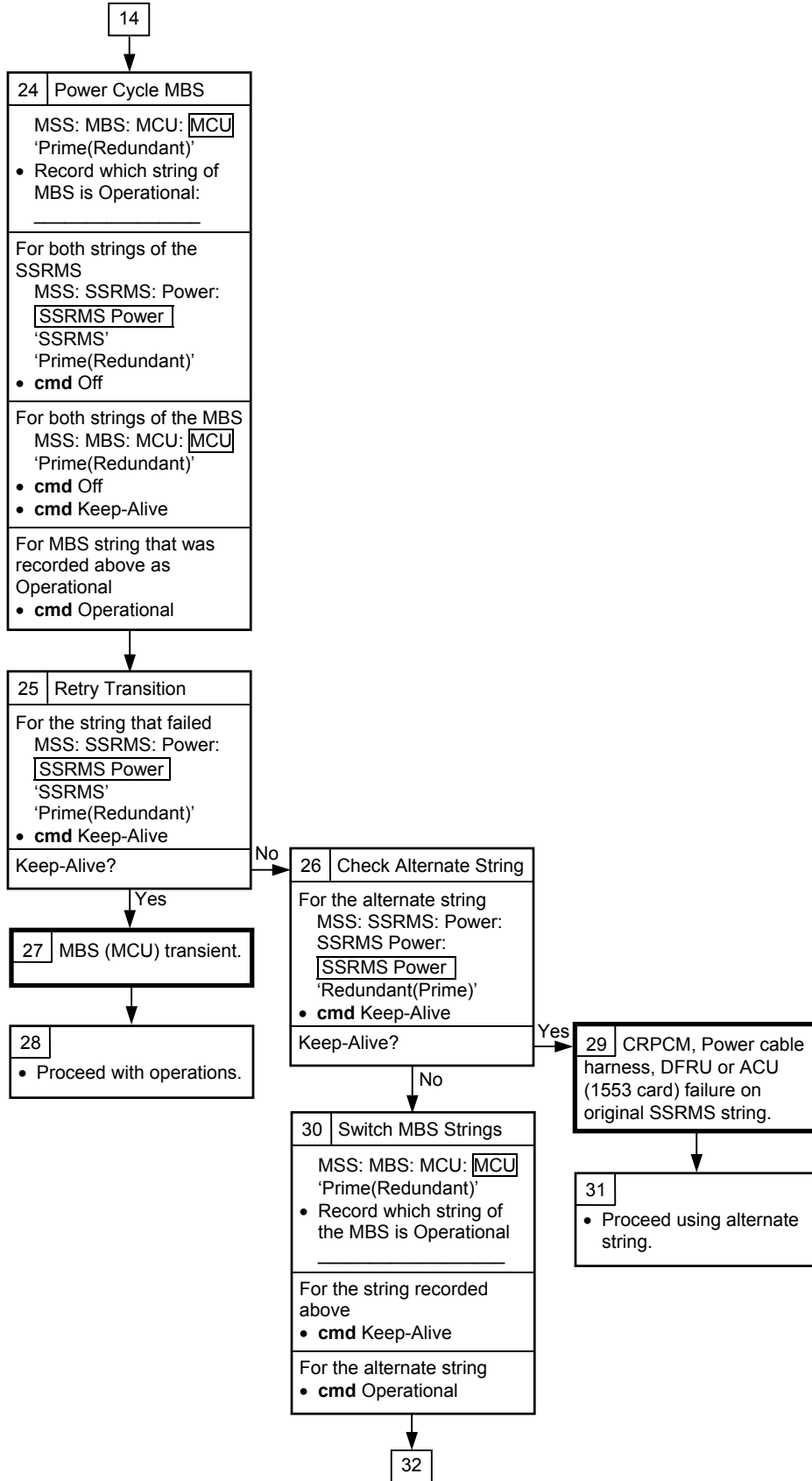

7.120 SSRMS POWER-UP FROM OFF TO KA FAILURE

(RBT GEN/X2R4 - ALL/FIN) Page 5 of 6 pages

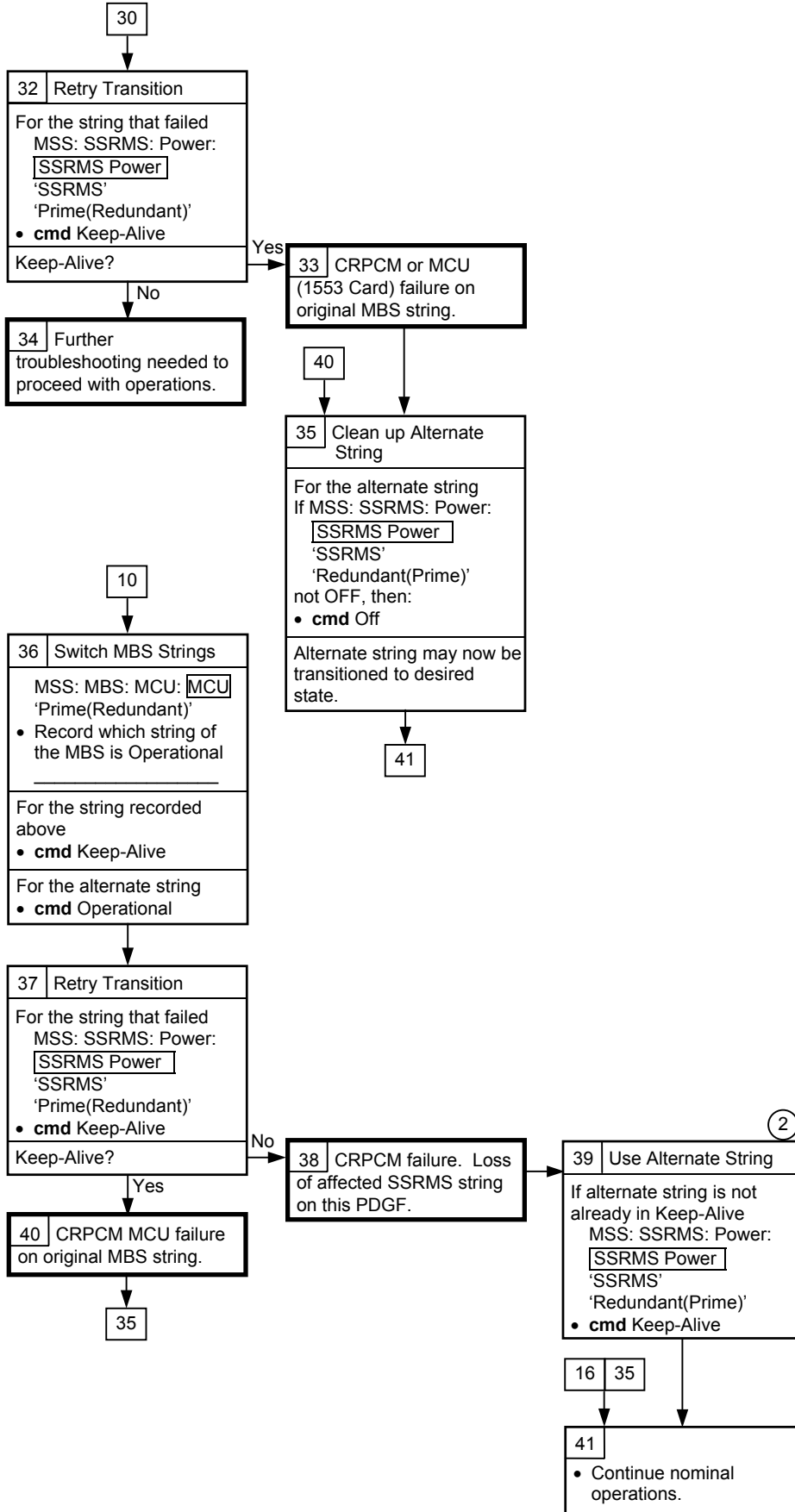

②
If both SSRMS strings have been powered Off for an extended period of time, refer to Flight Rule B12-104 for applicable warm-up times prior to commanding string to Operational.

②

Table 1. RPC/CRPC Reference Data

Base Location	Lab PDGF	MBS PDGF 1	MBS PDGF 2	MBS PDGF 3	MBS PDGF 4
	'S0 RPCs'	'MBS CRPCs'	'MBS CRPCs'	'MBS CRPCs'	'MBS CRPCs'
Prime	4B-D RPC 2	1P RPC 2	2P RPC 2	3P RPC 1	3P RPC 2
Redundant	3A-D RPC 2	1R RPC 2	2R RPC 2	3R RPC 1	3R RPC 2

MSS

C&W
ROBOTICS

7.121 SSRMS POWER-UP FROM KA TO OPERATIONAL FAILURE

(RBT GEN/X2R4 - ALL/FIN 1/SPN) Page 1 of 2 pages

C&W Messages Starting With 'Rxx - ...'

SSRMS Power Up from Keep-Alive to Operational Fails

Nominal Config:
RWS is active.

If SSRMS is based on MBS, MBS powered on both strings and Operational on one string.

If SSRMS is based on ISS PDGF, S0 and EXT MDMs configured for SEPS control.

Alternate SSRMS string is Off.

Affected SSRMS string was in Keep-Alive prior to transition.

No SSRMS SRT Errors in Alarm.

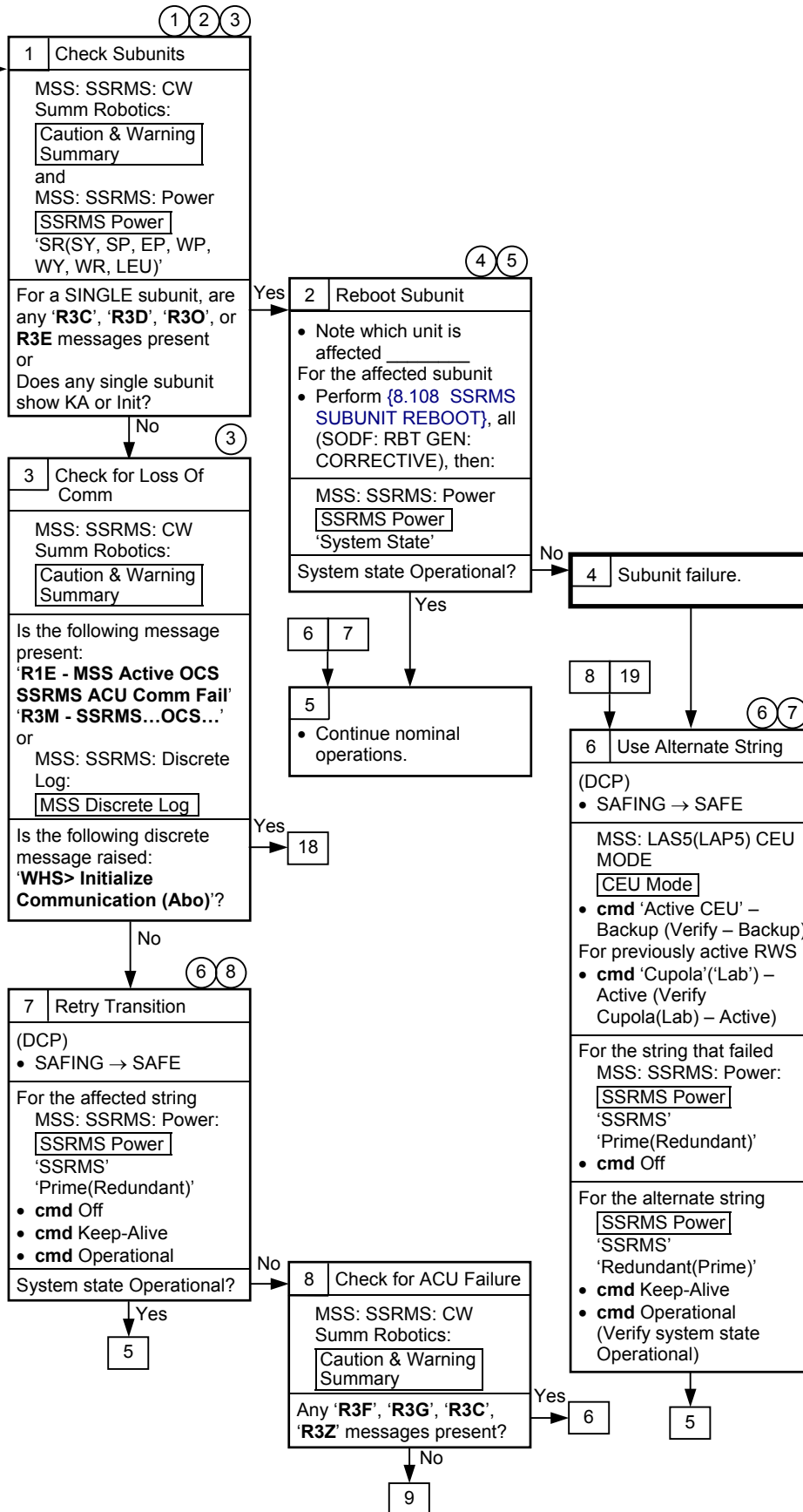

① {7.001 MSS FAILURE RESPONSE AND RECOVERY}, block 94 (SODF: RBT GEN: MALFUNCTION)

② Unless otherwise indicated, all displays in this procedure are on the PCS.

③ Only messages that may have come into alarm during the powerup sequence are of interest. The time hack noted in the log can be used to determine whether or not a message appeared within an appropriate timeframe. Messages may or may not persist in alarm.

④ SCR 21387.

⑤ Anticipated reset times are at least:
 Joint: 2min, 9s
 LEE: 2min, 22s

⑥ Operator must apply safing per SCR 22615.

⑦ SCR 28722

⑧ SCR 25802

7.121 SSRMS POWER-UP FROM KA TO OPERATIONAL FAILURE

(RBT GEN/X2R4 - ALL/FIN 1/SPN) Page 2 of 2 pages

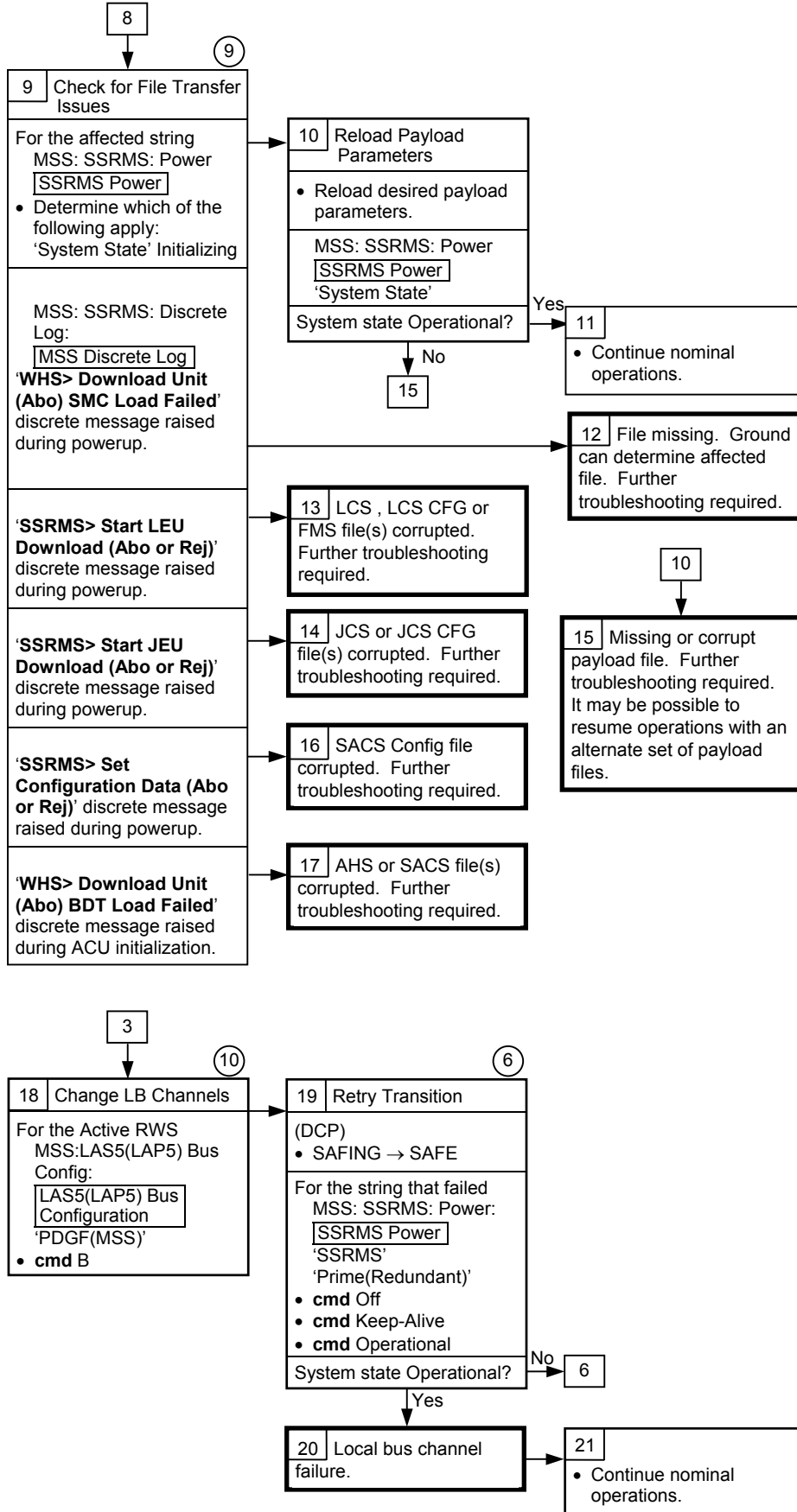

6 Operator must apply safing per SCR 22615.

9 The ground can check the ODIN File Transfer Status display to confirm the cause of the aborted file transfer.

10 PDGF LB if SSRMS is based on Lab PDGF, MSS LB if based on MBS PDGF.

MSS

C&W
ROBOTICS

C&W Messages with '... MSS ... Pwr Removed' in the Text

Nominal Config:
RWS is active.

7.200 MSS POWER REMOVED FAILURE
(RBT GEN/X2R4 - ALL/FIN/SPN) Page 1 of 5 pages

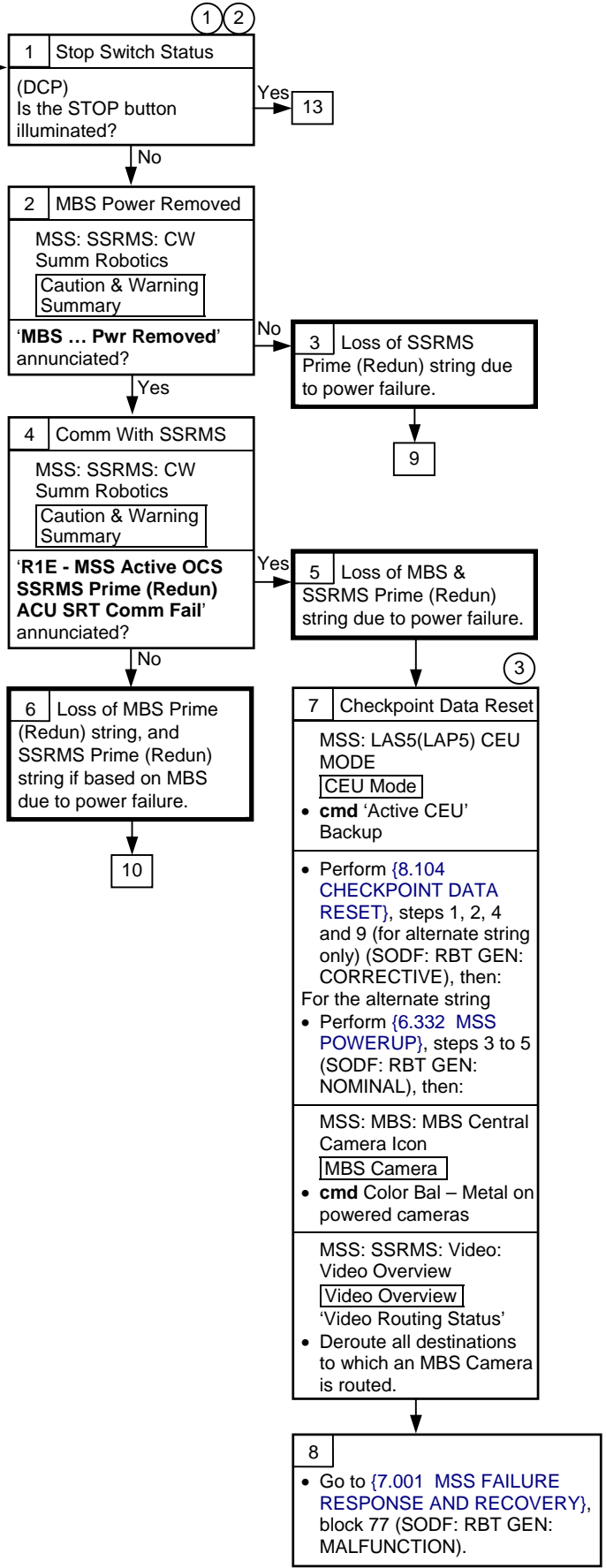

①
{7.001 MSS FAILURE RESPONSE AND RECOVERY}, block 76 (SODF: RBT GEN: MALFUNCTION)

②
Unless otherwise indicated, all displays in this procedure are on the PCS.

③
In place of the crew checkpoint procedure, ground should perform {8.270 GROUND MSS CHECKPOINT DATA RESET}, steps 2, 4, 6, 8 (GROUND HANDBOOK: ROBOTICS: NOMINAL) (SCR 21749).

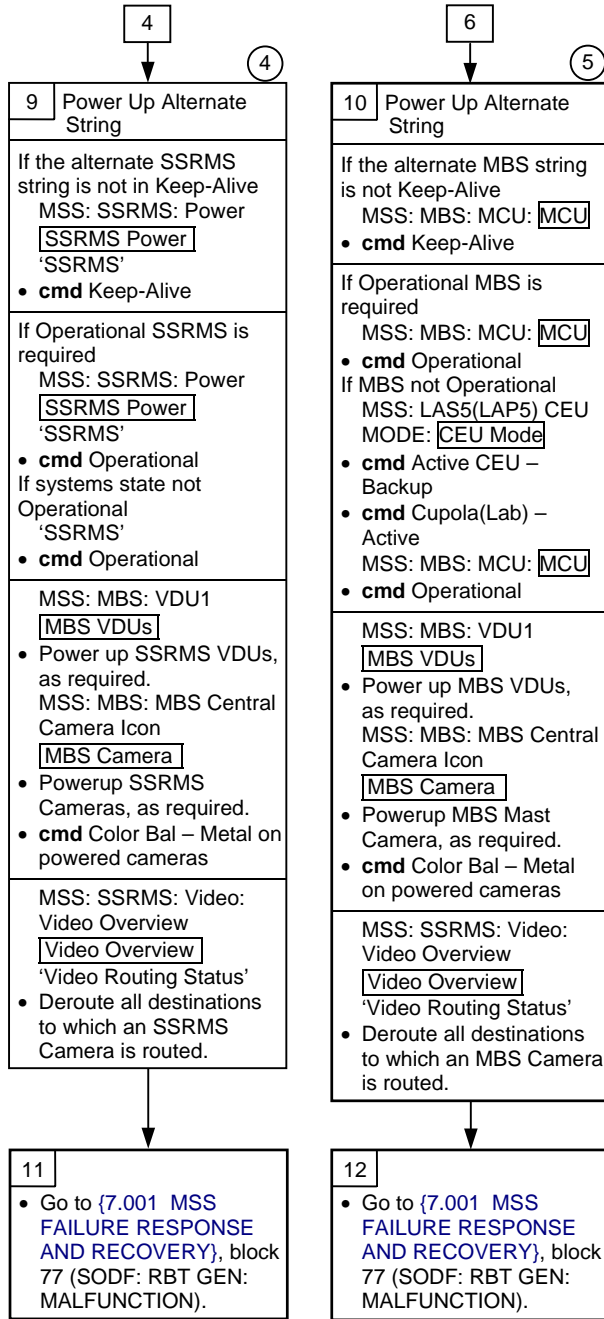

④
 If SSRMS had safing removed when the Power Removal Failure occurred, then per SCR 20380, the first go to Operational will fail, but a subsequent Go to Operational will work.

⑤
 If MBS had safing removed when the Power Removal Failure occurred, then per SCR 20380, the first go to Operational will fail, the operator must cycle the RWS to Backup and back to Active, and then a subsequent go to Operational will work.

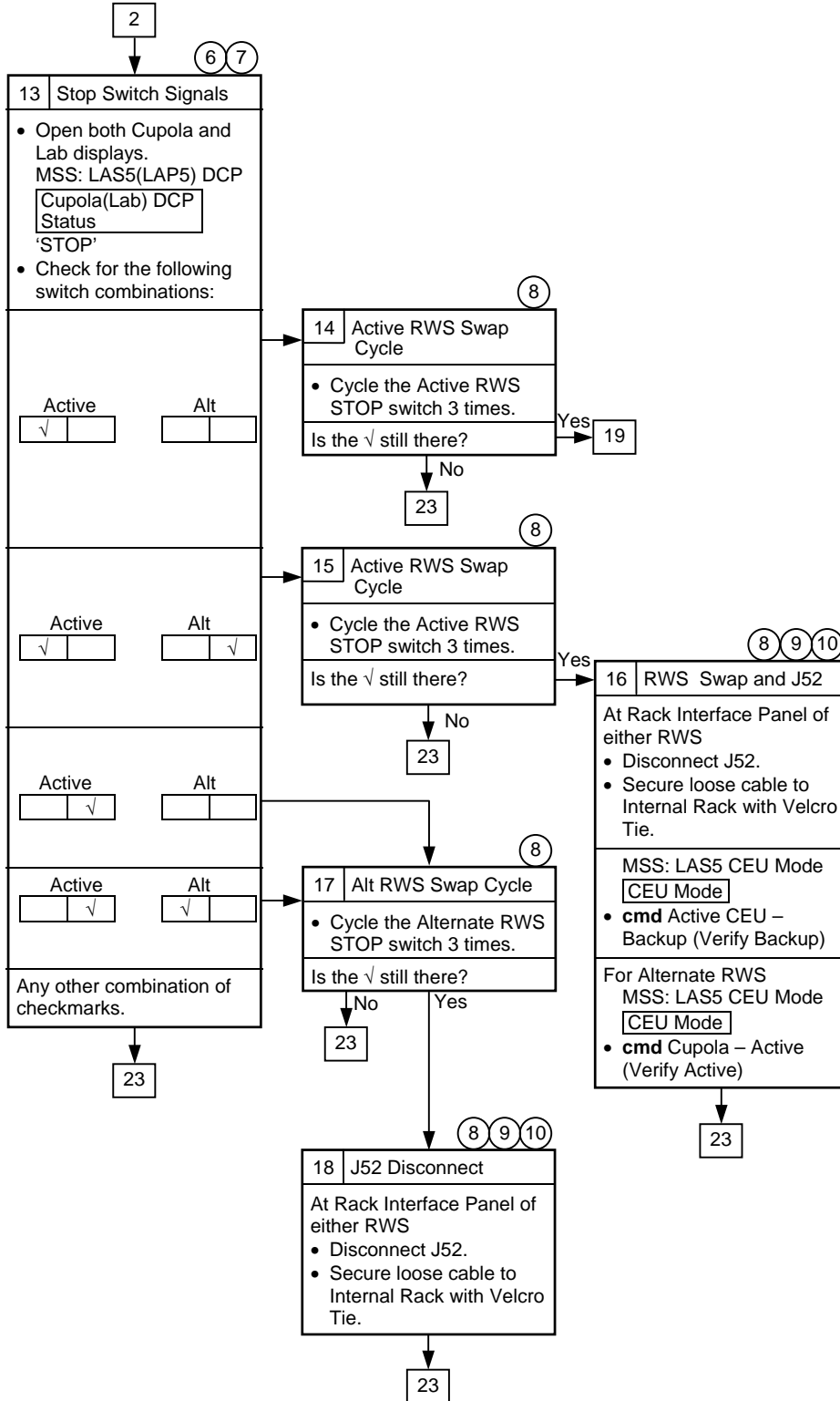

6 The STOP counter will not be reset in this procedure, so once recovery is complete crew has lost the ability to command Estop. Ground will reset the STOP counter later as a cleanup step.

7 Safing cannot be cancelled on the Active RWS while it is detecting a STOP switch signal.

8 This step contains actions that can only be performed by the crew.

9 Per flight rule B2-1, crew may disconnect J52 with the RWS powered.

10 Once the J52 connector has been disconnected, the capability to safe the MSS from the other RWS is lost.

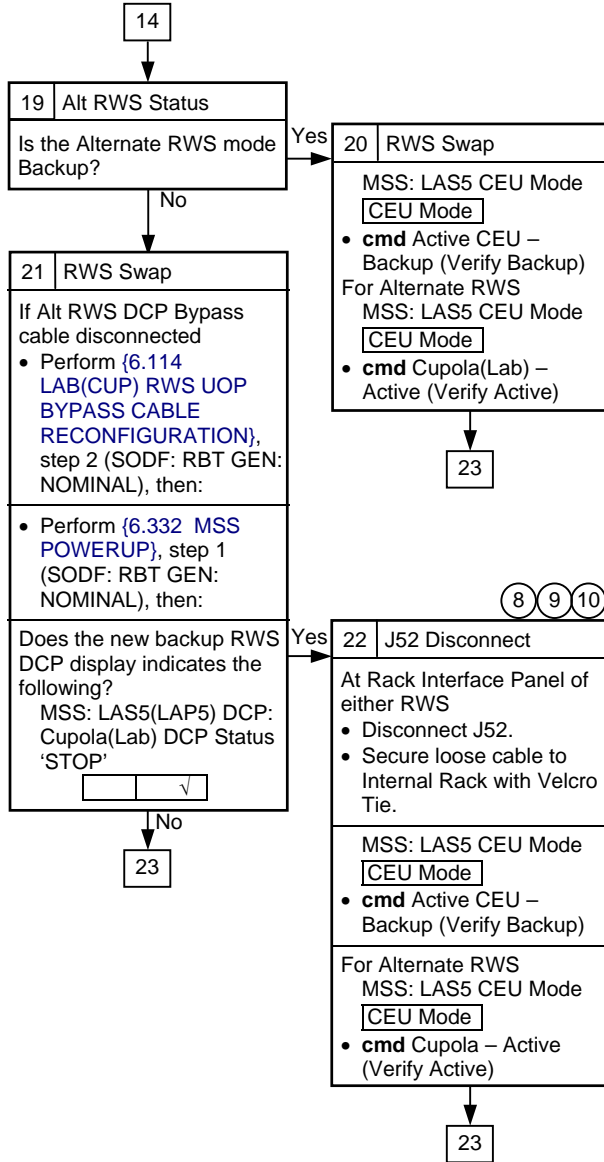

8 This step contains actions that can only be performed by the crew.

9 Per flight rule B2-1, crew may disconnect J52 with the RWS powered.

10 Once the J52 connector has been disconnected, the capability to Safe the MSS from the other RWS is lost.

8 9 10

7.200 MSS POWER REMOVED FAILURE

(RBT GEN/X2R4 - ALL/FIN/SPN)

13 14 15 16 17 18

20 21 22

23
Is the SSRMS based on an MBS PDGF?

Yes

No

25
For both MBS strings
MSS: MBS: MCU: MCU
• **cmd** Keep-Alive

If the MBS needs to be Operational then on the desired string
MSS: MBS: MCU: MCU

• **cmd** Operational

If MBS not Operational
MSS: LAS5(LAP5) CEU MODE: CEU Mode

• **cmd** Active CEU – Backup

• **cmd** Cupola(Lab) – Active

MSS: MBS: MCU: MCU

• **cmd** Operational

For the desired SSRMS string

MSS: SSRMS: Power SSRMS Power
'SSRMS'

• **cmd** Keep-Alive

If Operational SSRMS is required, then on the desired string

• **cmd** Operational

If Systems State not Operational
'SSRMS'

• **cmd** Operational

MSS: MBS: VDU1 MBS VDUs

• Power up MSS VDUs, as required.

MSS: MBS: MBS Central Camera Icon MBS Camera

• Powerup MSS cameras, as required.

• **cmd** Color Bal – Metal on powered cameras

MSS: SSRMS: Video: Video Overview Video Overview

'Video Routing Status'

• Deroute all destinations to which an MSS Camera is routed.

• Deflect THC and RHC to Hardstops in positive and negative directions for all axes.

24 Checkpoint Data Reset

MSS: LAS5(LAP5) CEU MODE CEU Mode

• **cmd** 'Active CEU' Backup

• Perform {8.104 CHECKPOINT DATA RESET}, steps 1, 2, 4 and 9 (SODF: RBT GEN: CORRECTIVE), then:

• Perform {6.332 MSS POWERUP}, steps 3 to 5 (SODF: RBT GEN: NOMINAL), then:

MSS: MBS: MBS Central Camera Icon MBS Camera

• **cmd** Color Bal – Metal on powered cameras

MSS: SSRMS: Video: Video Overview Video Overview

'Video Routing Status'

• Deroute all destinations to which an MBS Camera is routed.

• Deflect THC and RHC to Hardstops in positive and negative directions for all axes.

26

• Go to {7.001 MSS FAILURE RESPONSE AND RECOVERY}, block 77 (SODF: RBT GEN: RECOVERY).

27

• Go to {7.001 MSS FAILURE RESPONSE AND RECOVERY}, block 77 (SODF: RBT GEN: RECOVERY).

3

4 5

3

In place of the crew checkpoint procedure, ground should perform {8.270 GROUND MSS CHECKPOINT DATA RESET}, steps 2, 4, 6, 8 (GROUND HANDBOOK: ROBOTICS: NOMINAL) (SCR 21749).

4

If SSRMS had safing removed when the Power Removal failure occurred, then per SCR 20380, the first go to Operational will fail, but a subsequent go to Operational will work.

5

If MBS had safing removed when the Power Removal failure occurred, then per SCR 20380, the first go to Operational will fail, the operator must cycle the RWS to Backup and back to Active, and then a subsequent go to Operational will work.

This Page Intentionally Blank

MSS

C&W
ROBOTICS

C&W Messages with 'R1E - MSS ... SRT COMM' in the Text

Nominal Config:
RWS is Active.

EXT, S0(S1,P1)
MDMs configured for SEPS control.

MT SSBAs powered.

7.201 MSS COMM FAILURE (RBT GEN/X2R4 - ALL/FIN/SPN) Page 1 of 8 pages

{7.001 MSS FAILURE RESPONSE AND RECOVERY}, block 78, and 92 (SODF: RBT GEN: MALFUNCTION).

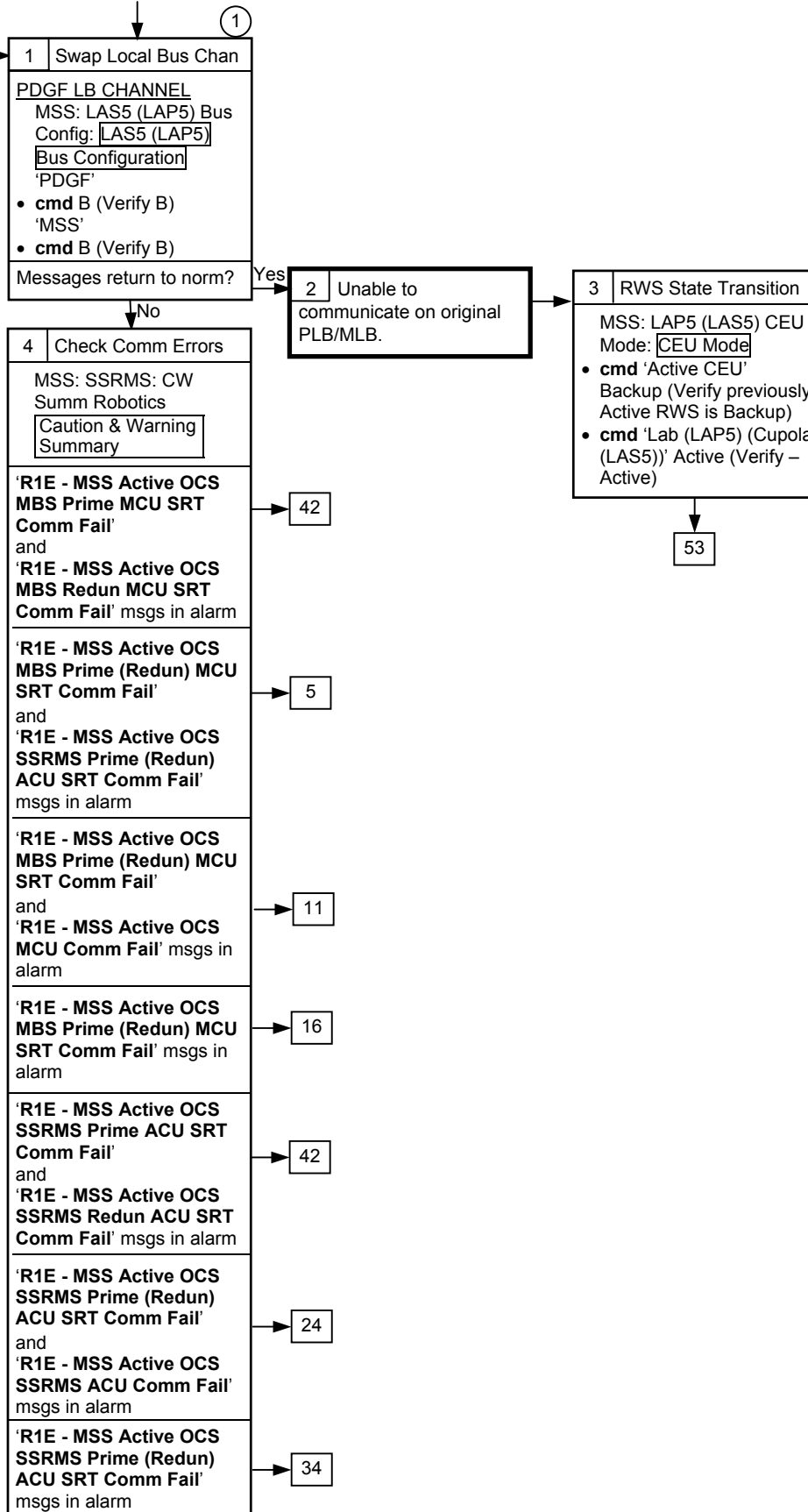

①
Unless otherwise noted, all displays in the procedures are on the PCS.

7.201 MSS COMM FAILURE
 (RBT GEN/X2R4 - ALL/FIN/SPN) Page 2 of 8 pages

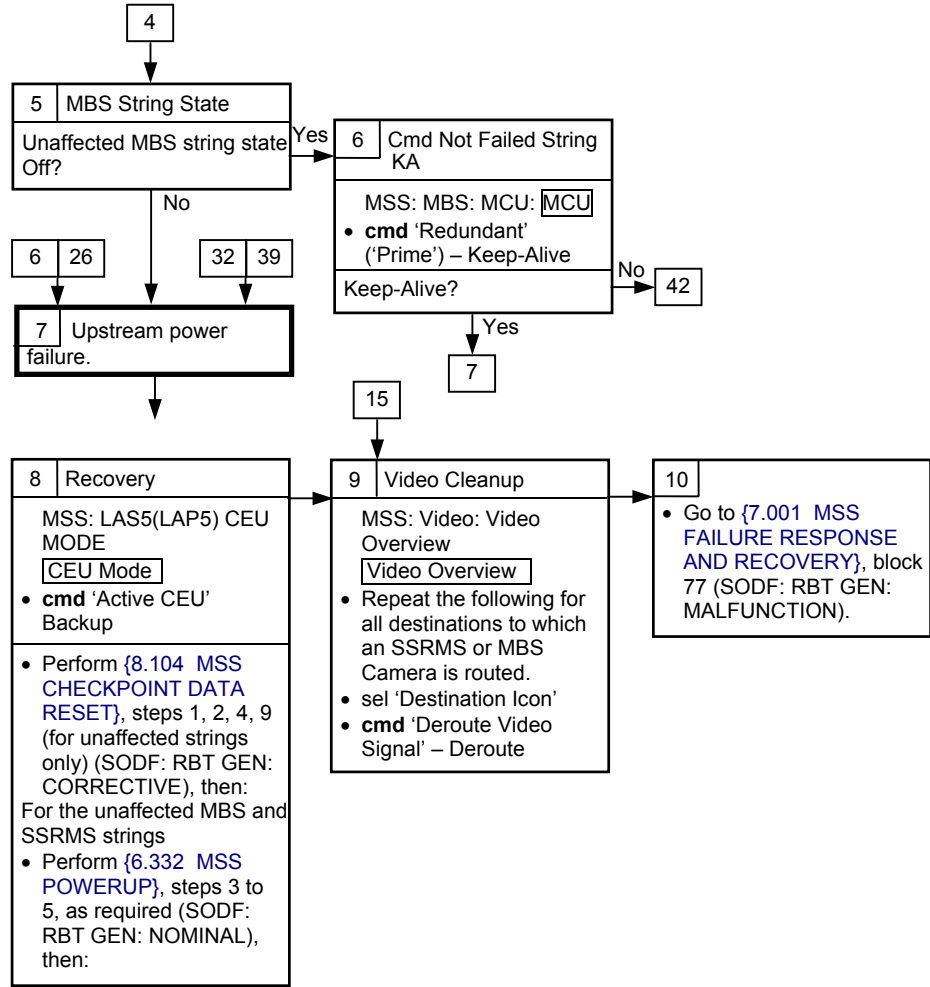

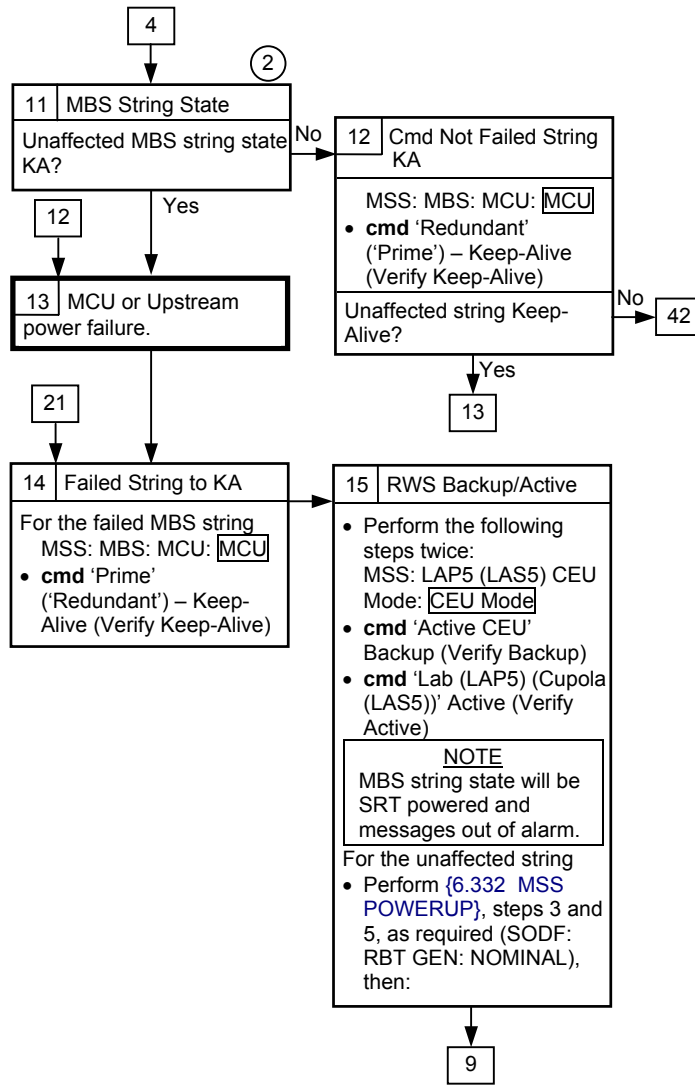

② SSRMS safing can be cancelled and SSRMS recovery operations can resume in the presence of an MBS CAT-1 error.

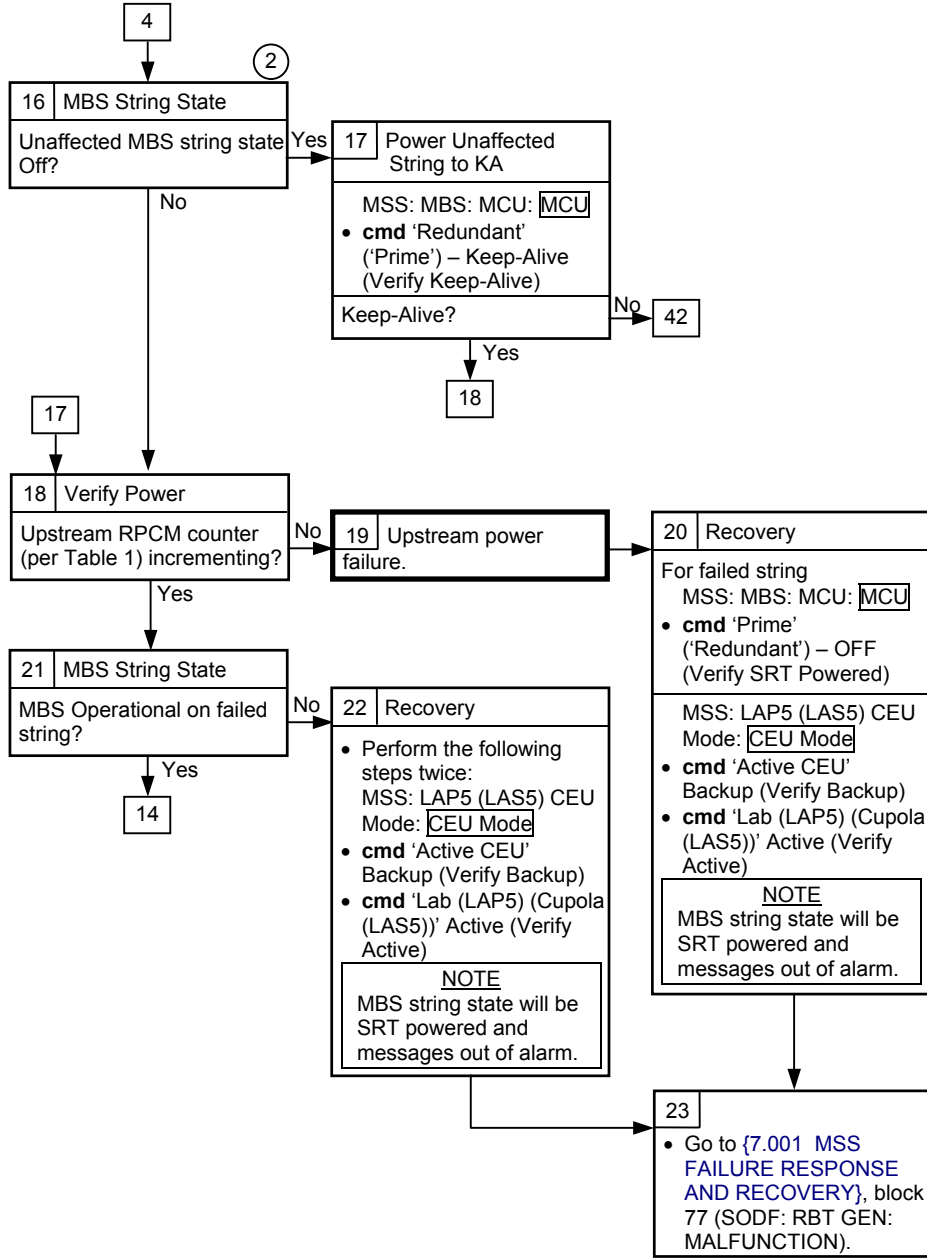

② SSRMS safing can be cancelled and SSRMS recovery operations can resume in the presence of an MBS CAT-1 error.

Table 1. Upstream RPCM Checks

MT Worksite	Prime	Redundant
1	RPCM S34B F	RPCM S33A F
2	RPCM S14B E	RPCM S13A E
3	RPCM S14B F	RPCM S13A F
4	RPCM S04B A	RPCM S03A A
5	RPCMS04B B	RPCM S03A B
6	RPCM P14B F	RPCM P13A F
7	RPCM P14B E	RPCM P13A E
8	RPCM P34B F	RPCM P33A F
9	RPCM S43A B	RPCM S41A B
10	RPCM P44A B	RPCM P42A B

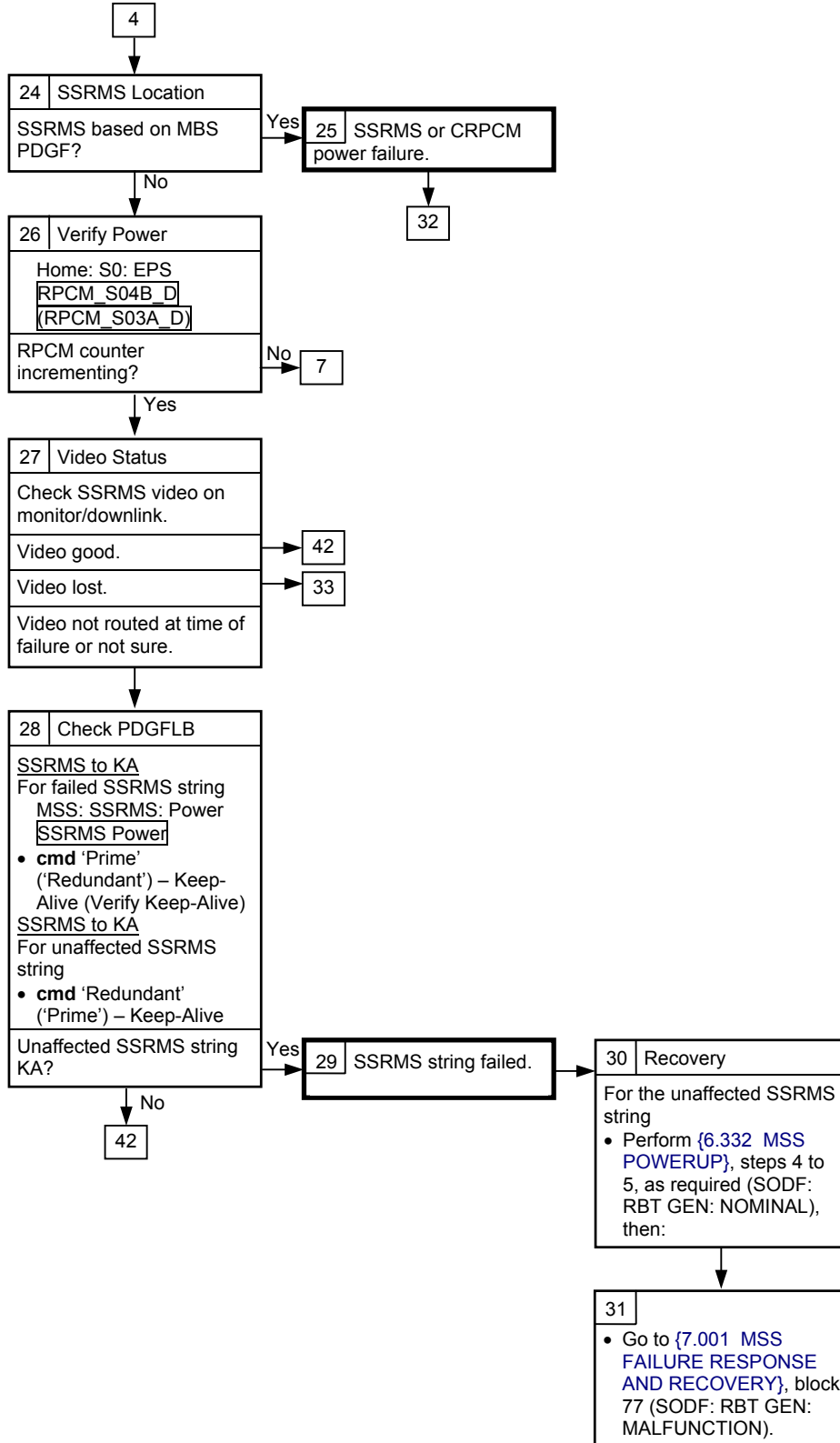

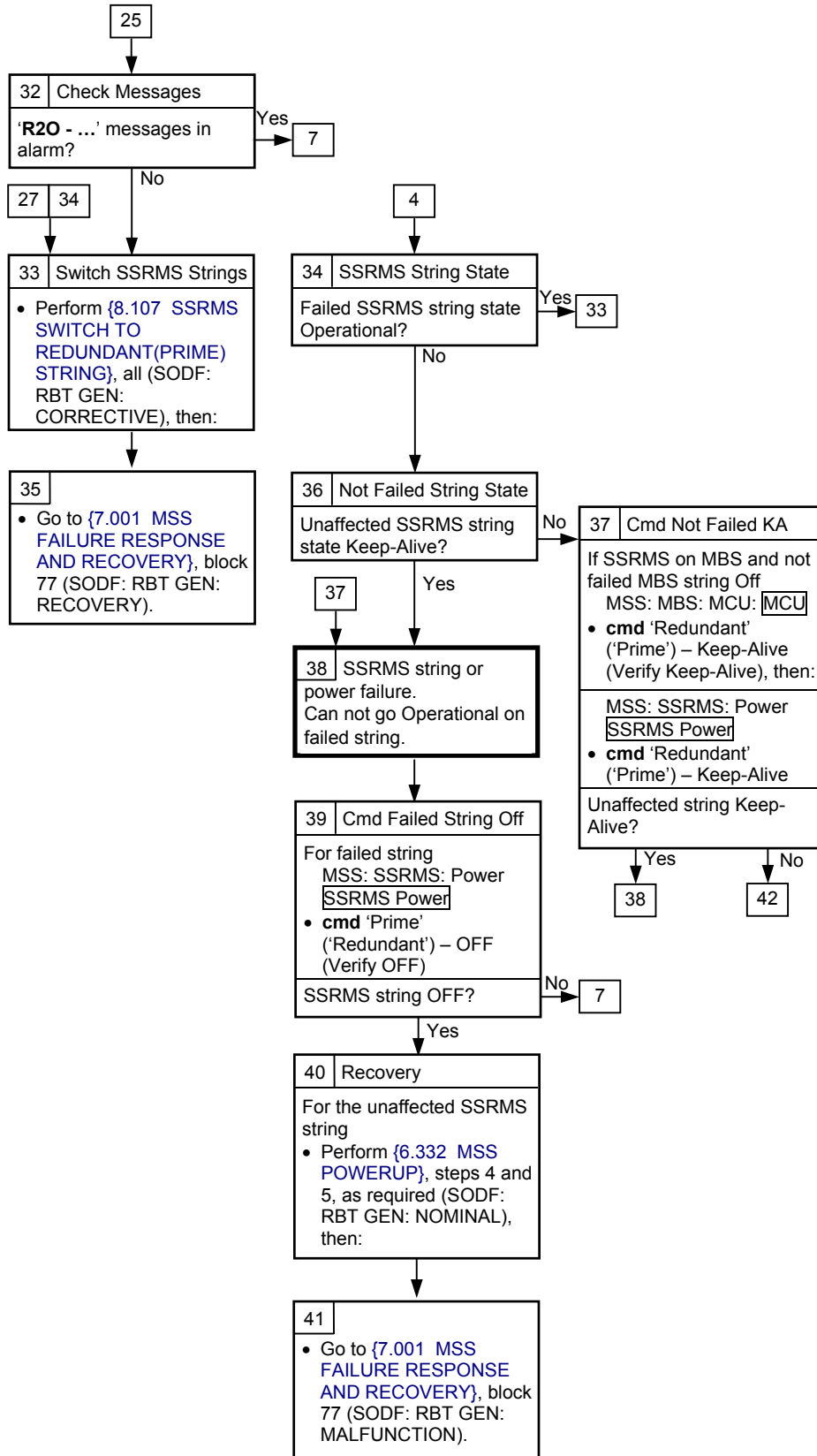

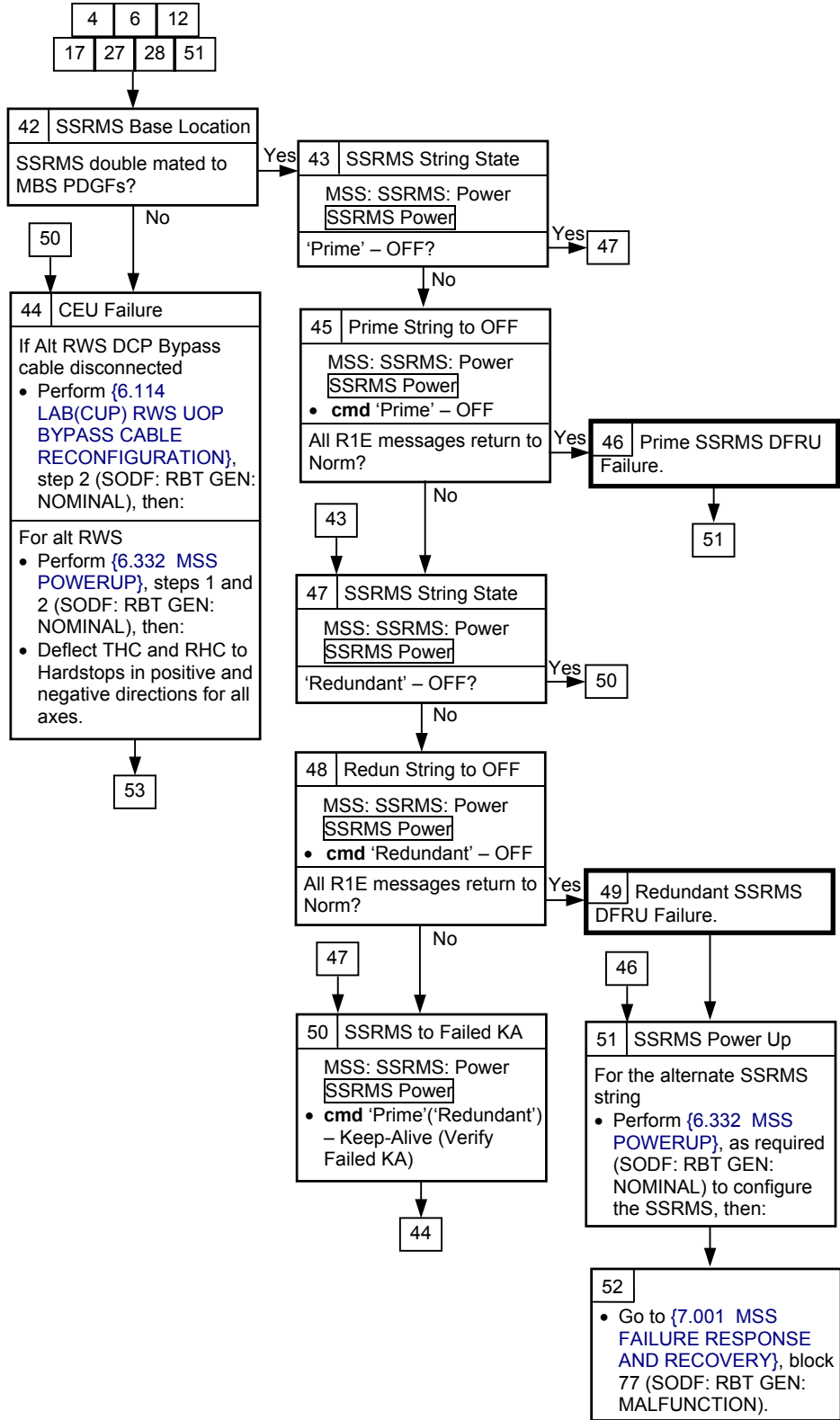



53	MSS State Cleanup
MSS: MBS: MCU: MCU If 'Prime' – SRT Powered <ul style="list-style-type: none"> • cmd 'Prime' – Keep-Alive (Verify Keep-Alive) If 'Redundant' – SRT Powered <ul style="list-style-type: none"> • cmd 'Redundant' – Keep-Alive (Verify Keep-Alive) 	
If SSRMS based on MBS MSS: MBS: MCU: MCU <ul style="list-style-type: none"> • cmd 'Prime' ('Redundant') – Operational (Verify – Systems State – Operational) 	
MSS: SSRMS: Power SSRMS Power If 'Prime' – Failed KA <ul style="list-style-type: none"> • cmd 'SSRMS' Prime – Off (Verify – Off) • cmd 'SSRMS' Prime – Keep-Alive (Verify Keep-Alive) 	
If 'Redundant' – Failed KA <ul style="list-style-type: none"> • cmd 'SSRMS' Redundant – Off (Verify – Off) • cmd 'SSRMS' Redundant – Keep-Alive (Verify Keep-Alive) 	
If required to power up MBS and SSRMS to Operational <ul style="list-style-type: none"> • Perform {6.332 MSS POWERUP}, steps 3 to 5, as required (SODF: RBT GEN: NOMINAL), then: 	

54	<ul style="list-style-type: none"> • Go to {7.001 MSS FAILURE RESPONSE AND RECOVERY}, block 77 (SODF: RBT GEN: MALFUNCTION).
----	---

MSS

C&W
ROBOTICS

7.300 ACTIVE RWS FAILURE
(RBT GEN/X2R4 - ALL/FIN 1/SPN) Page 1 of 11 pages

{7.001 MSS FAILURE RESPONSE AND RECOVERY},
block 74 (SODF: RBT GEN: MALFUNCTION)
{7.101 RWS TRANSITION TO ACTIVE FAILURE},
block 5, (SODF: RBT: GEN: MALFUNCTION

①
Unless otherwise indicated, all displays in this procedure are on the PCS.

C&W Messages With 'R1...' in the Text in Alarm

RWS Drops to Backup or Unconfigured from Active or DCP Lost Power or OCS Frame Counter Stops Incrementing.

Nominal Config:
CB-EXT FDIR enabled for affected RWS.

DCP Lighting switch not in OFF position.

Monitor brightness not fully dimmed.

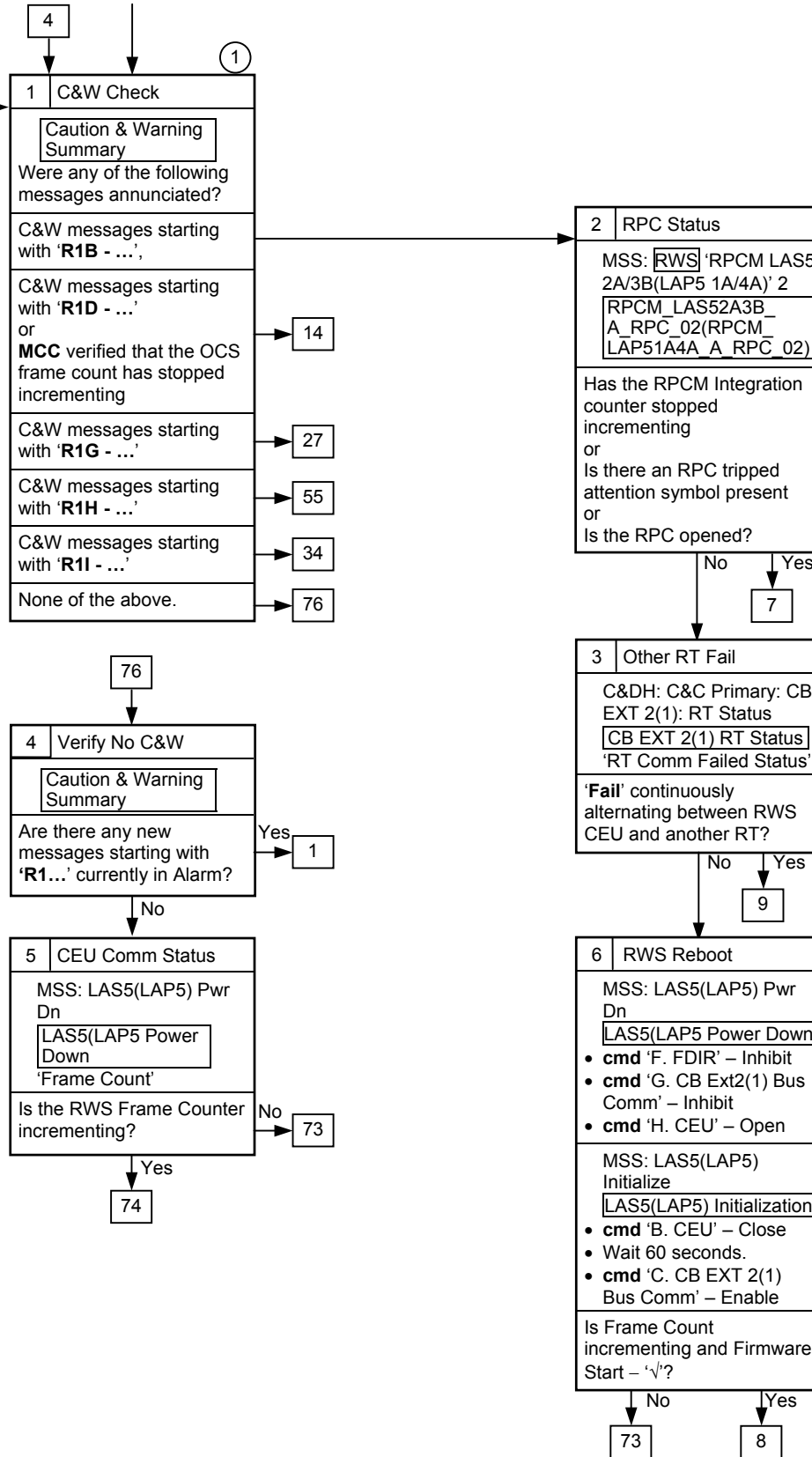

7.300 ACTIVE RWS FAILURE
(RBT GEN/X2R4 - ALL/FIN 1/SPN) Page 2 of 11 pages

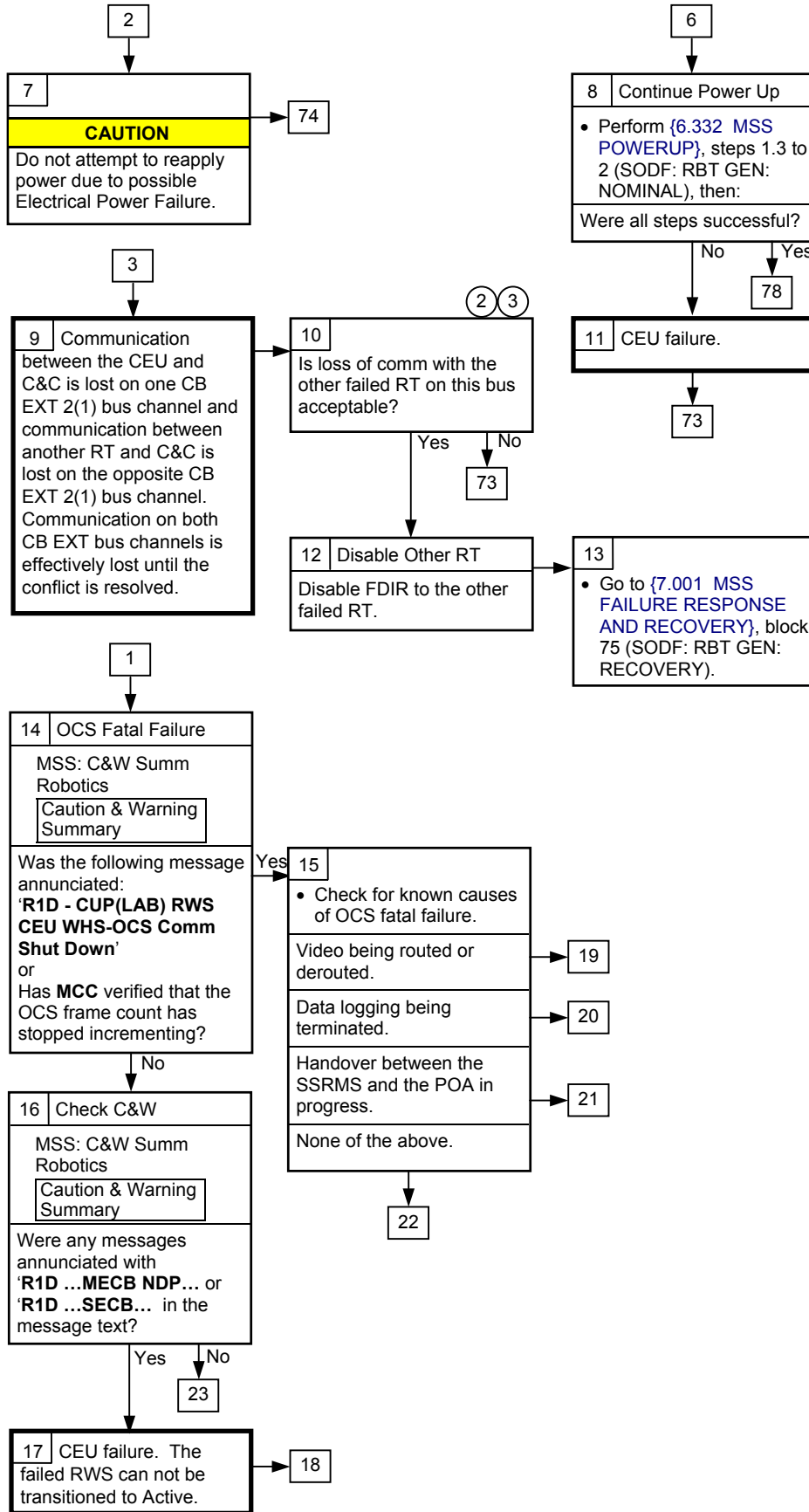

②
List of remote terminals on CB EXT 1:
13 LCA IMCA-1
22 RWS CEU-1
24 MDM EXT1
25 RPCM S0-1A-C
26 MDM PMCU1

List of remote terminals on CB EXT 2:
13 LCA IMCA-2
22 RWS CEU-2
24 MDM EXT2
25 RPCM S0-2B-C
26 MDM PMCU2

③
This step is ground only and requires coordination within the flight control team.

7.300 ACTIVE RWS FAILURE
(RBT GEN/X2R4 - ALL/FIN 1/SPN) Page 3 of 11 pages

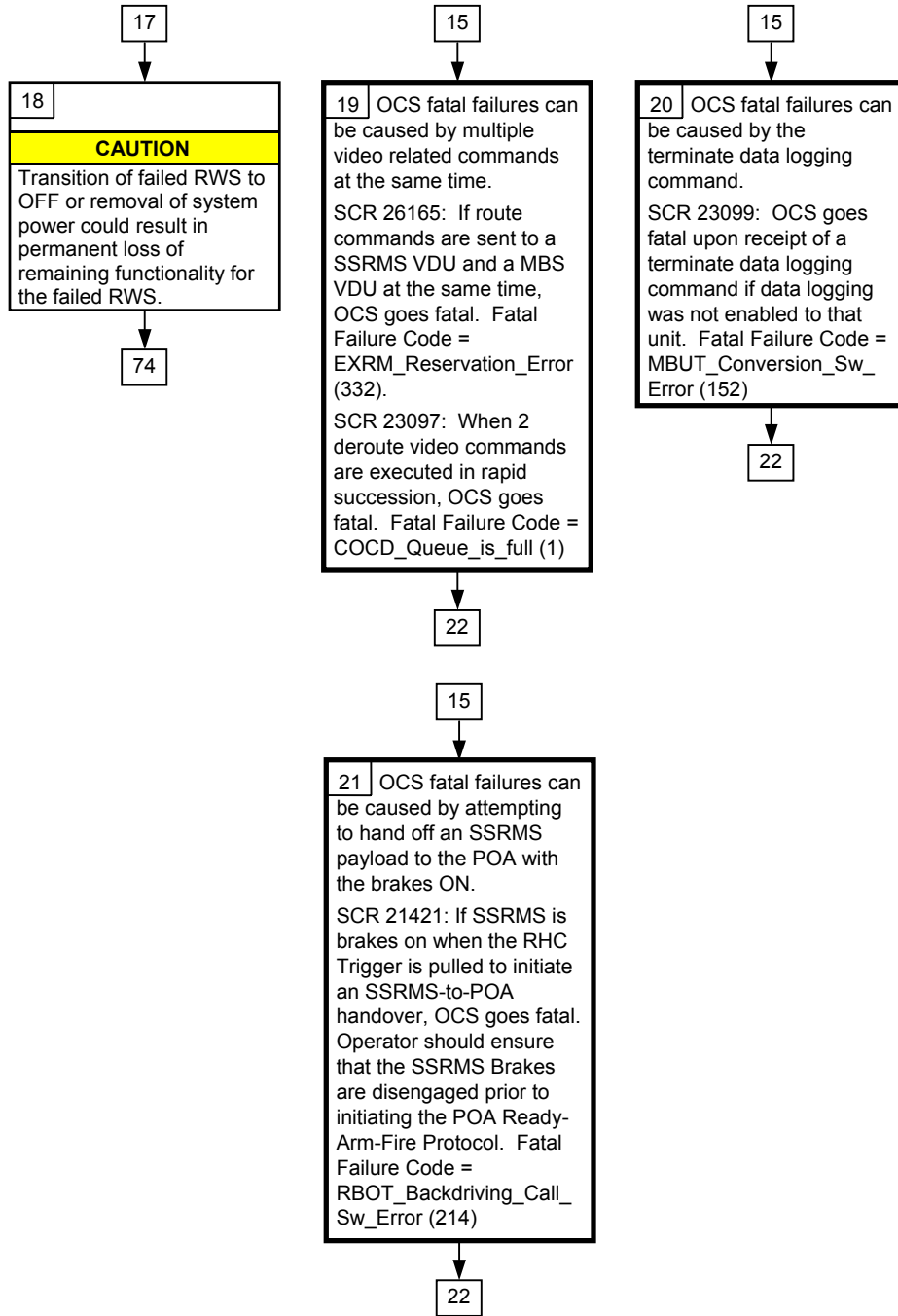

7.300 ACTIVE RWS FAILURE
 (RBT GEN/X2R4 - ALL/FIN 1/SPN) Page 4 of 11 pages

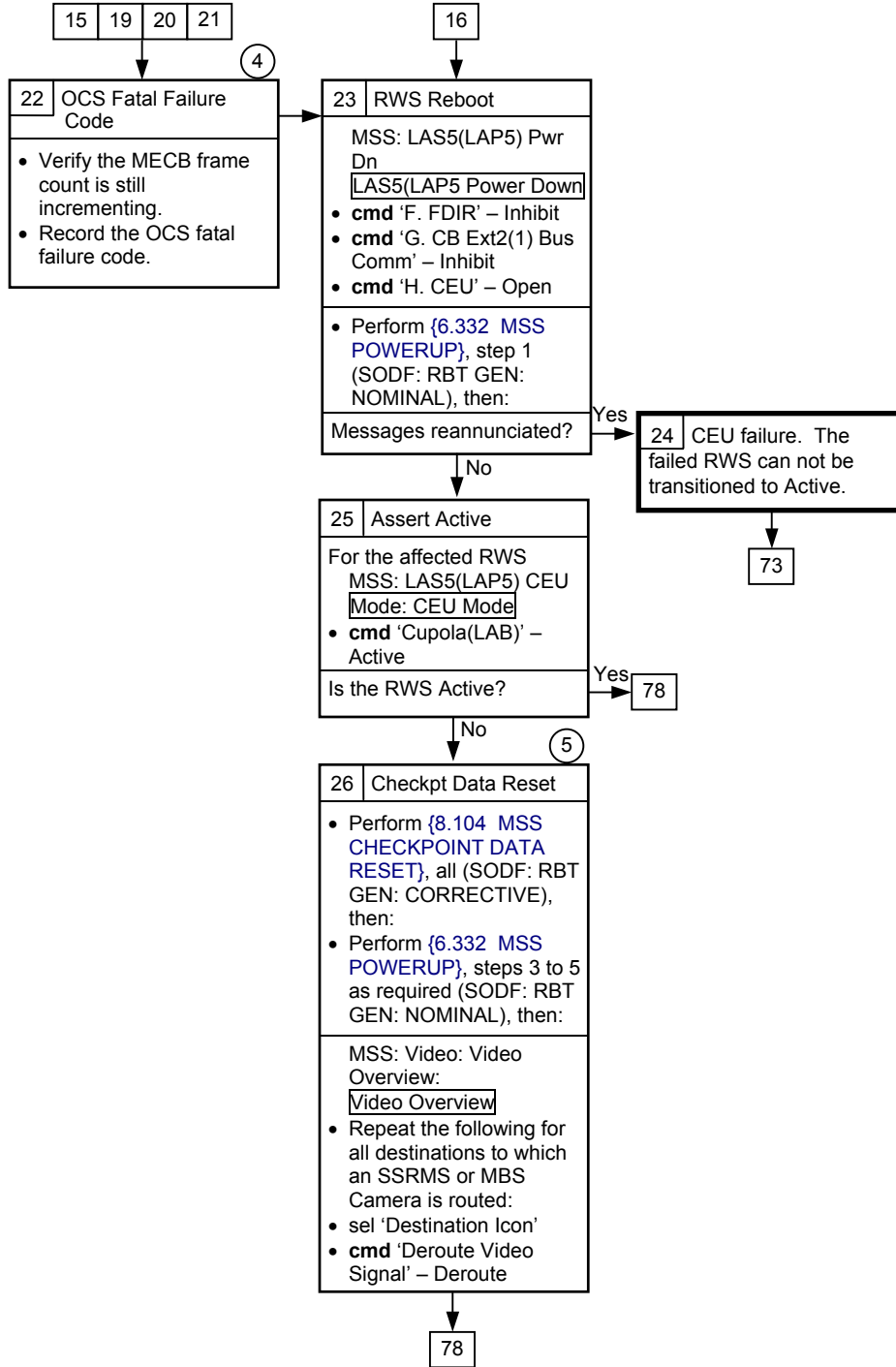

④ The fatal failure code is only available in telemetry to the ground. Refer to SSP 50496 - OCS to RWS ICD PIRN 11 for the list of fatal failure codes.
 SCR 26165: If a Sync_Route command is issued to OCS with both SSRMS and MBS VDUs selected and VDUs ON both systems are powered on, the OCS will halt processing with fatal error EXRM Reservation Error (code 332 decimal).

⑤ SCR 24574, 28414

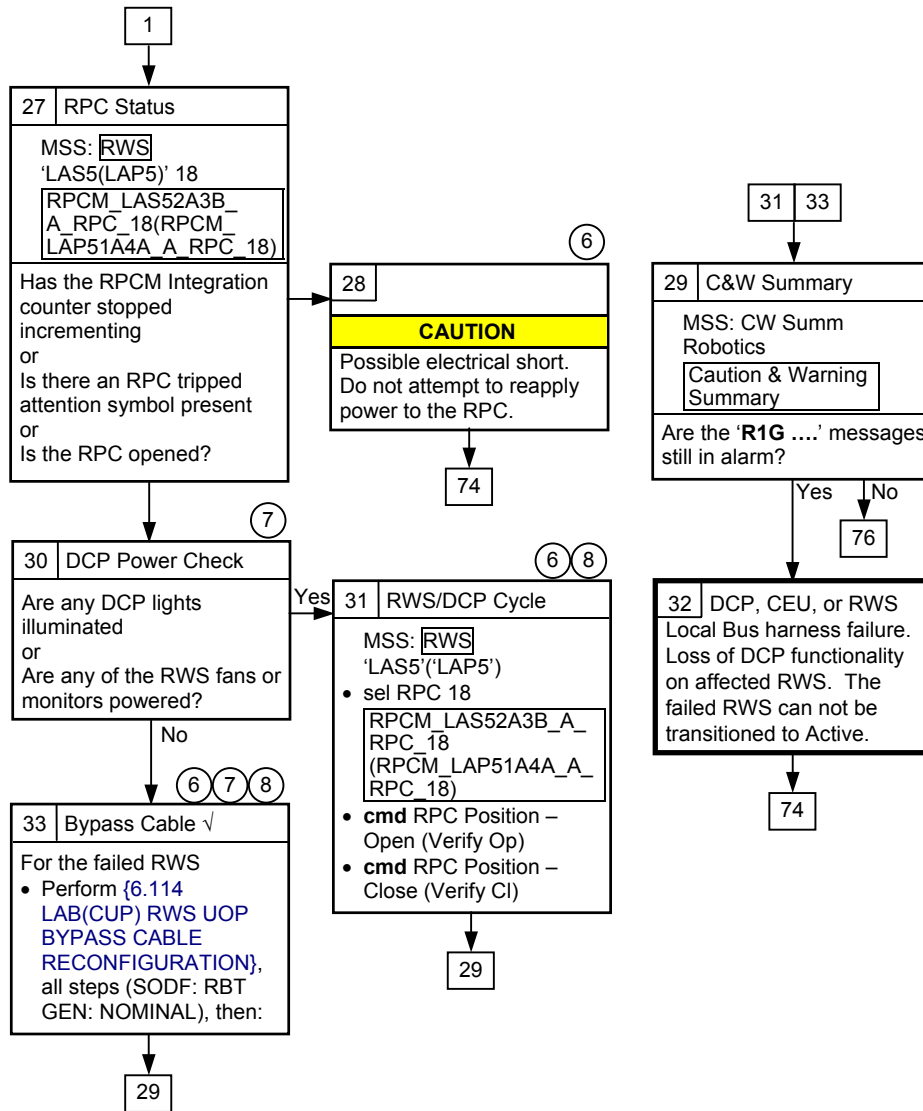

⑥ PCS at the failed RWS will be on battery power while the RPC is opened.

⑦ This step must be performed by the crew.

⑧ Expect 'R1G - ...', 'R1H' and 'R1J' messages to be announced when this block is executed. If the power cycle is successful, all messages should return to NORM when DCP power is reapplied. Monitors may display anomalous video when power is reapplied to the DCP. Valid video can be recovered by routing a test pattern or another video view to each.

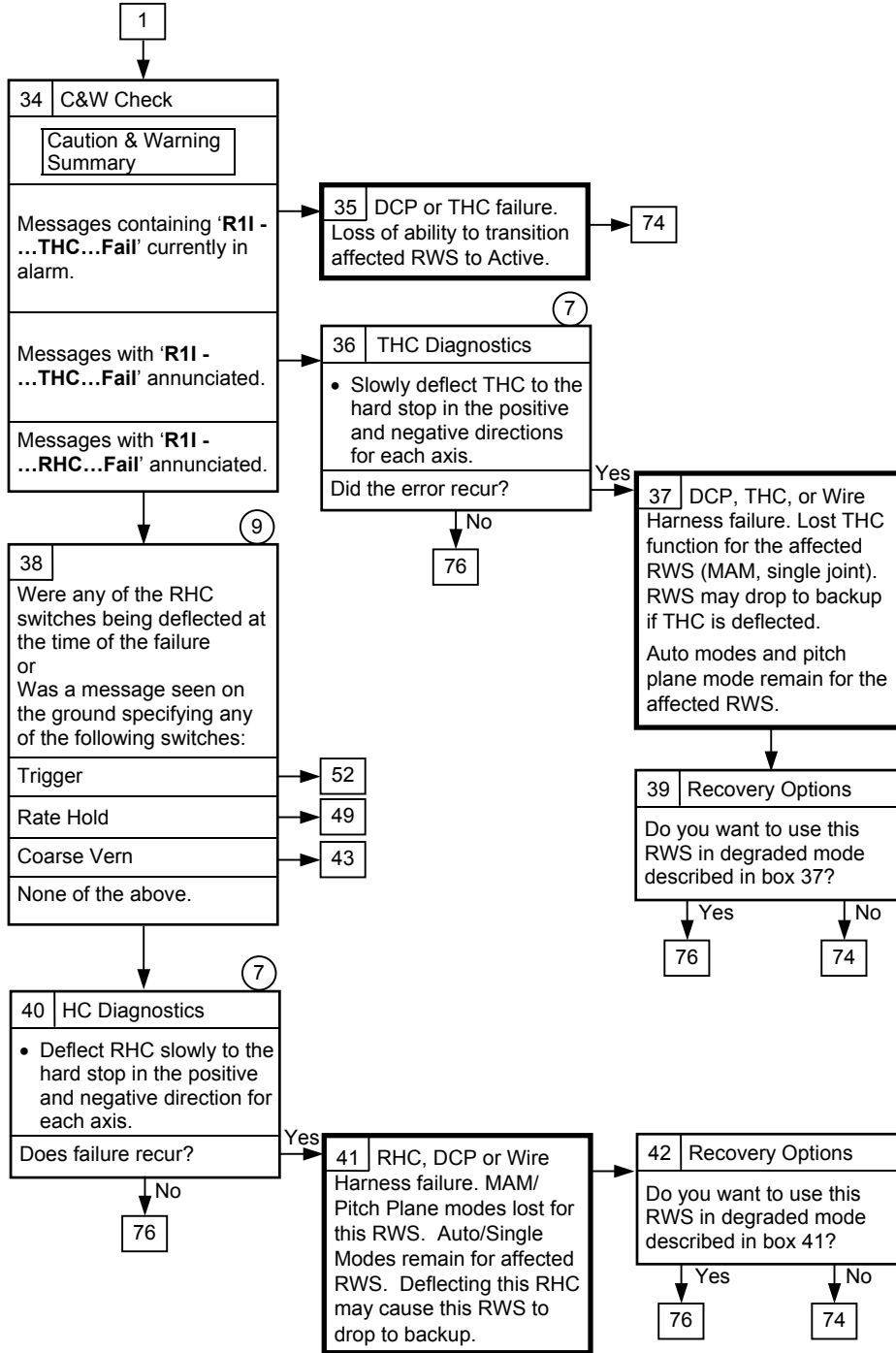

⑦ This step must be performed by the crew.

⑨ Cross check messages can be seen on the ground in the REM; however, due to timing considerations, these messages are not always seen. Persistent cross checks can also be identified on the PCS DCP display.

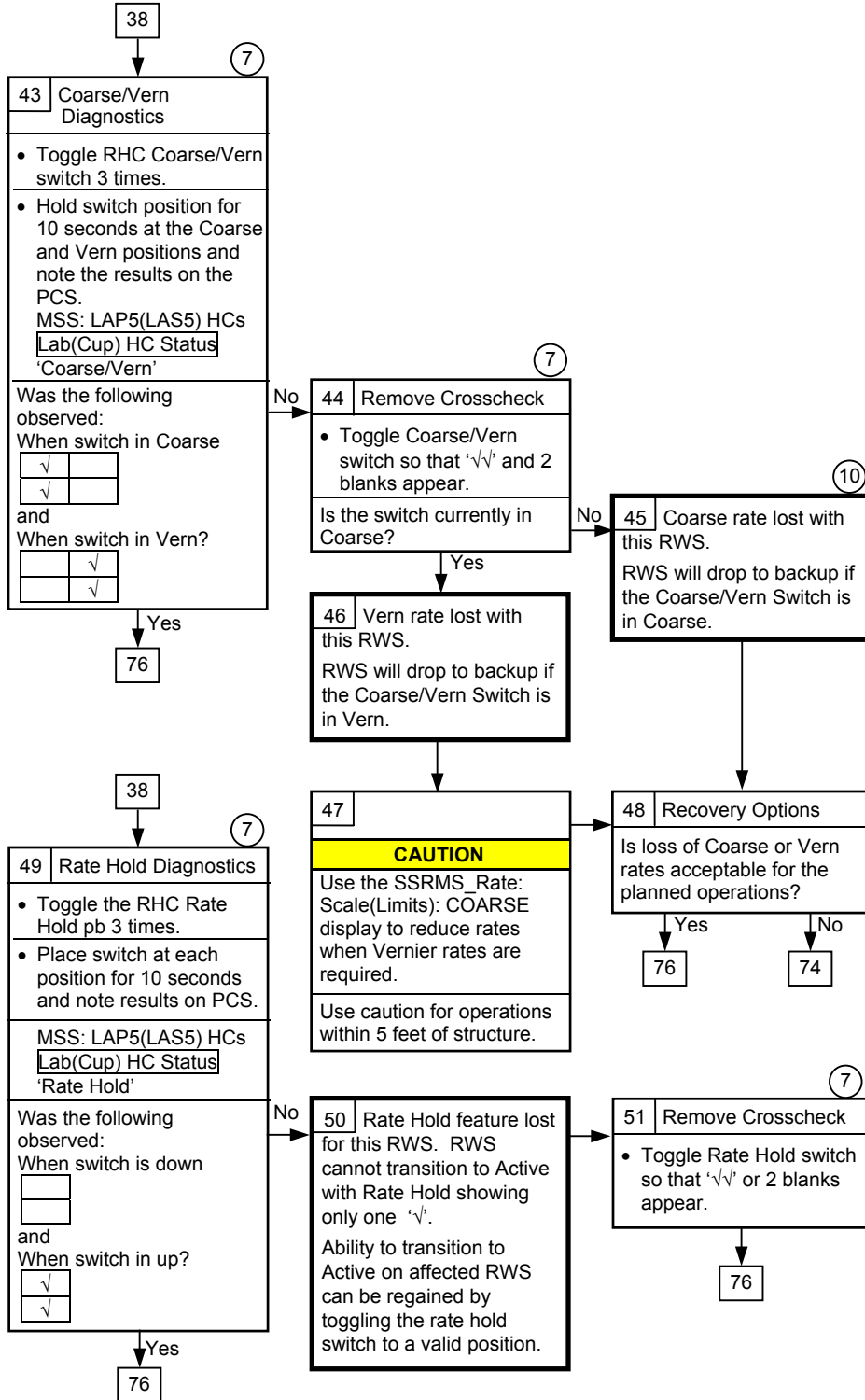

(7) This step must be performed by the crew.

(10) The SSRMS joint diagnostics may provide false fail without Coarse Rates include: Buck Regulator, Switch Motor Drive Switches, and Motor Windings tests.

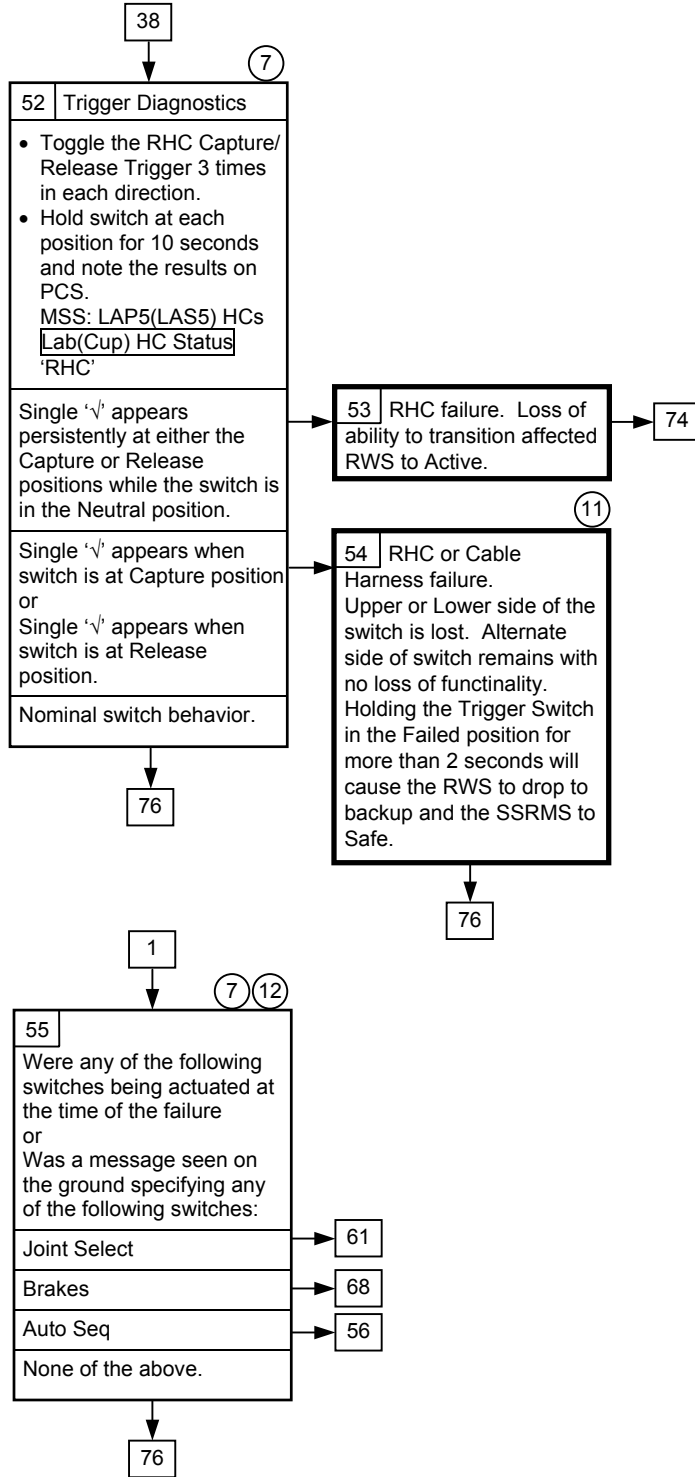

⑦ This step must be performed by the crew.

⑪ MSS software does not distinguish between the Lower and Upper side of the Capture/Release Trigger Switch. The operator-defined action from the LEE page is executed whenever the Trigger is moved from the neutral position regardless of direction.

⑫ Both on orbit and in simulations, the RWS has dropped to backup when assertive DCP Switch throws were not used.

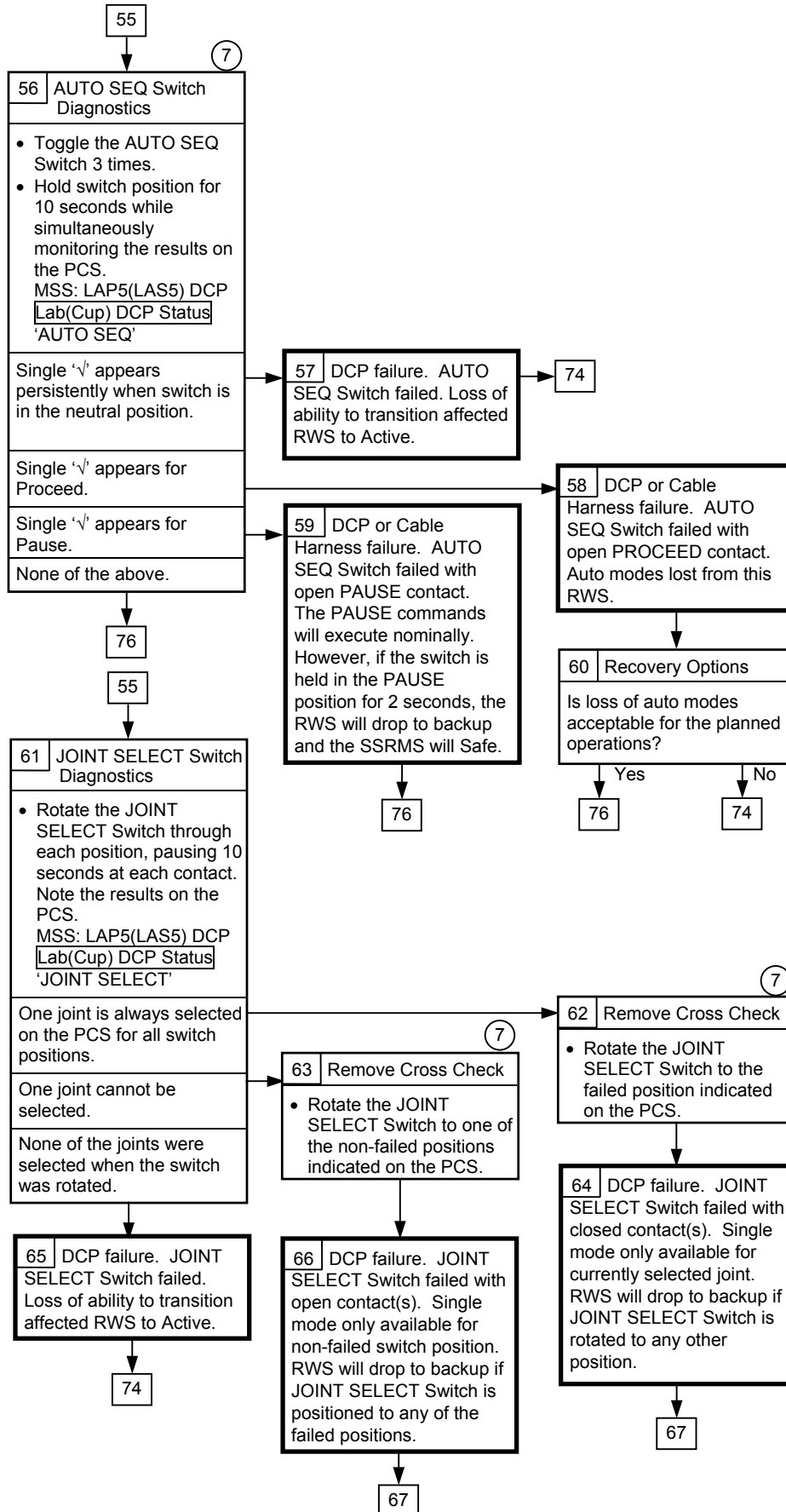

7 This step must be performed by the crew.

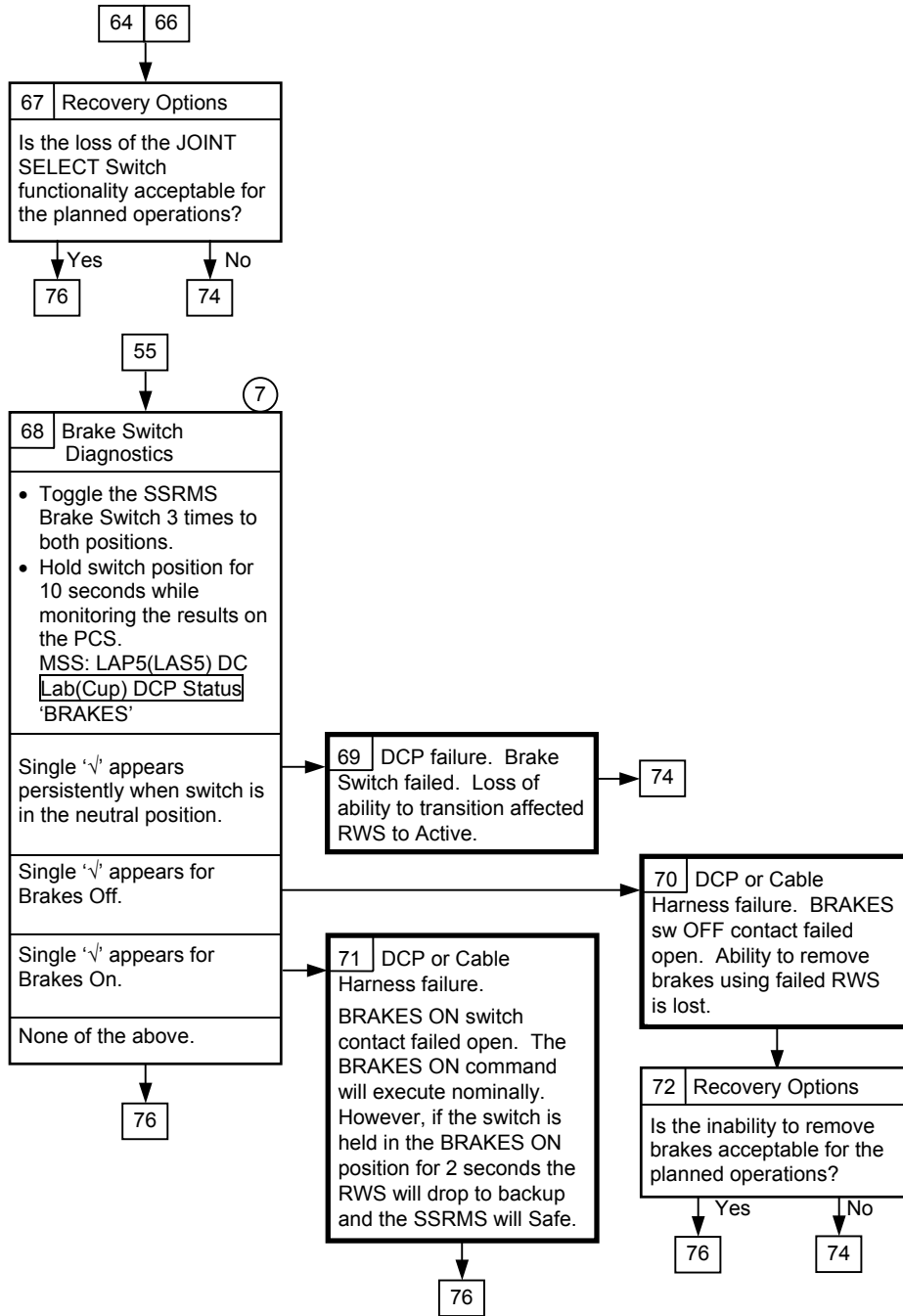

7
 This step must be performed by the crew.

7.300 ACTIVE RWS FAILURE
(RBT GEN/X2R4 - ALL/FIN 1/SPN) Page 11 of 11 pages

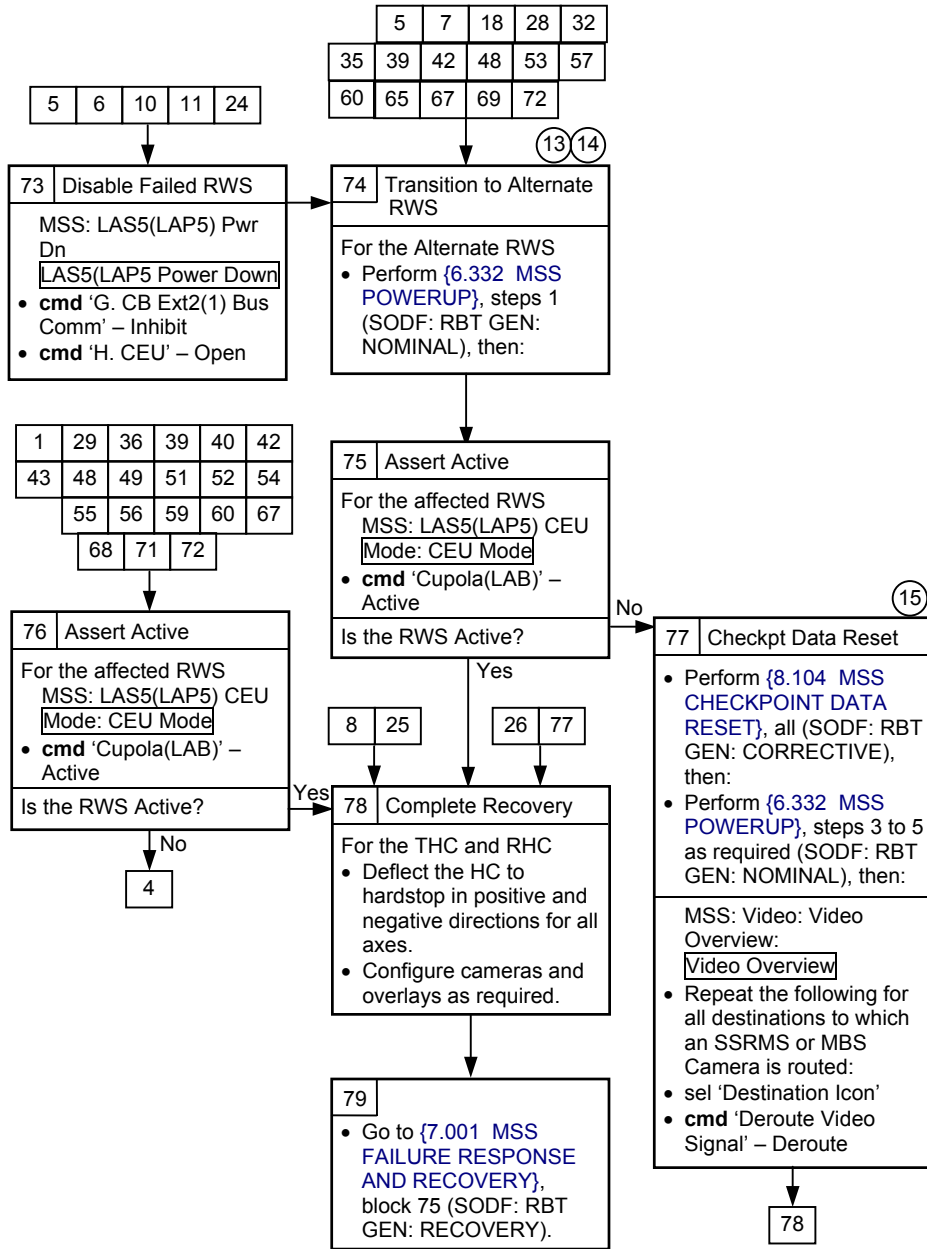

13 If failed workstation status remains in Backup in the CCS after power is removed, expect 'R1E - MSS Active OCS Other RWS Comm Fail' when powering up the alternate RWS.

14 Ground will perform required cleanup of the failed RWS.

15 SCR 24574, 28414

This Page Intentionally Blank

MSS

7.510 SSRMS LEE CAPTURE FAILURE

(RBT GEN/X2R4 - ALL/FIN/SPN)

Page 1 of 18 pages

C&W
ROBOTICS

C&W Messages
with 'Rxx-...' in
the Text

LEE Capture
Does Not
Complete.

Nominal Config:
Active RWS.

SSRMS Operational
with brakes Off.

If SSRMS is based
on MBS, MBS
powered on both
strings and
Operational on one
string.

If SSRMS is based
on ISS PDGF, S0
and EXT MDMs
configured for
SEPS control.

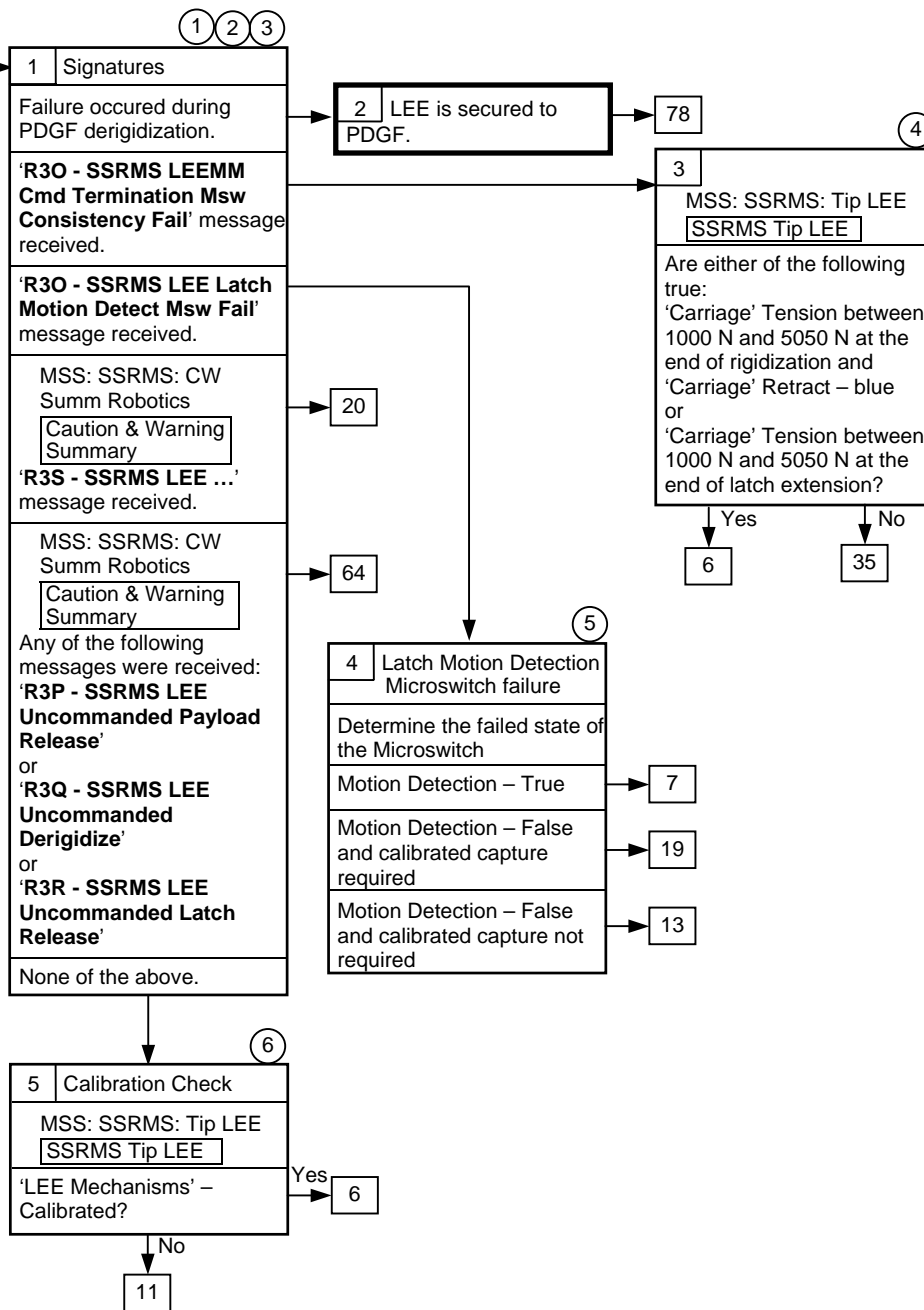

①
{7.001 MSS
FAILURE
RESPONSE AND
RECOVERY}, block
125 (SODF: RBT
GEN:
MALFUNCTION)

②
Unless otherwise
indicated, all
displays in the
procedures are on
the PCS.

③
Throughout this
procedure, MSS
commands should
not be issued while
the trigger is hot.
To change the
configuration of the
system, safe to exit
LEE operations
(SCR 14662).

④
SCR 25421

⑤
Latch Motion
Detection
Microswitch status is
only available on the
ground.

⑥
If calibration is lost,
completing the
capture to hardstops
will result in loss of
uncommanded
derigidization
monitoring. Also, if
mating is required,
checkpoint data
must be reset. This
procedure gives
steps to do so.

7.510 SSRMS LEE CAPTURE FAILURE

(RBT GEN/X2R4 - ALL/FIN/SPN)

3 5 8 79

4 9

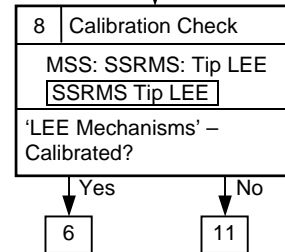
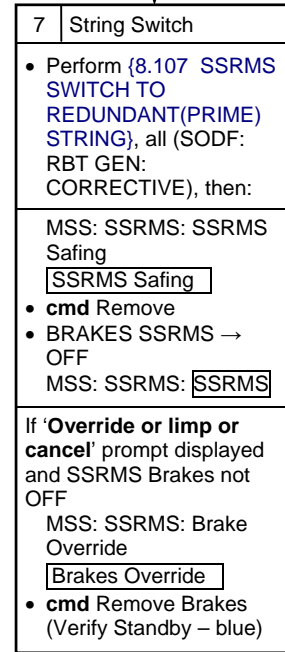
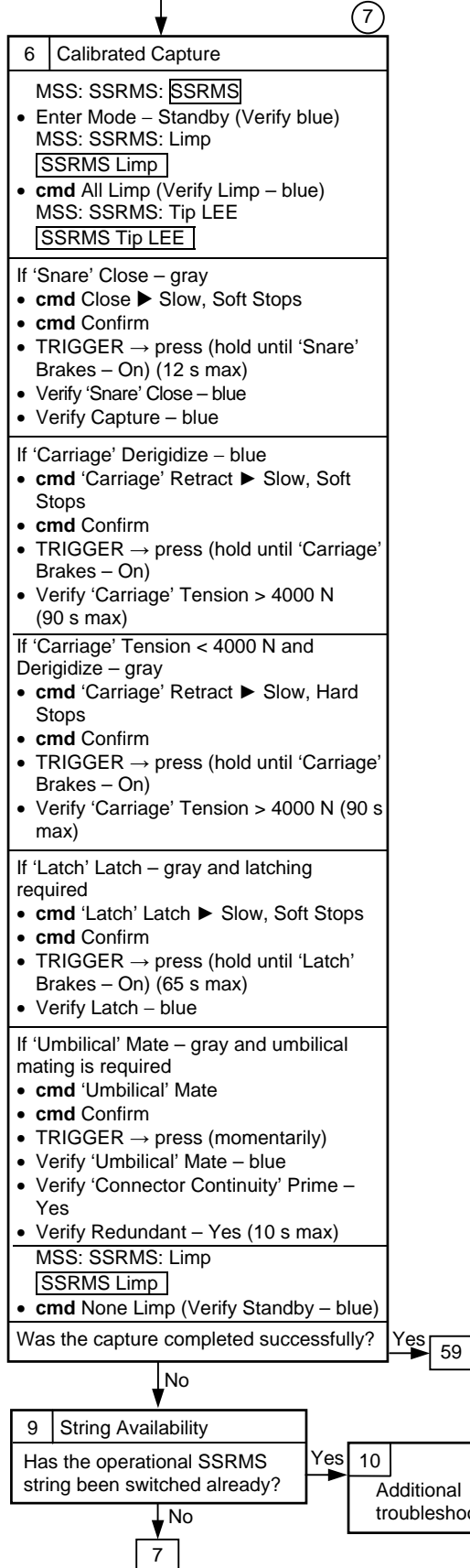

⑦ A locked joint will not be limped if SSRMS is in Manual mode when "All Limp" command is issued (SCR 29341).

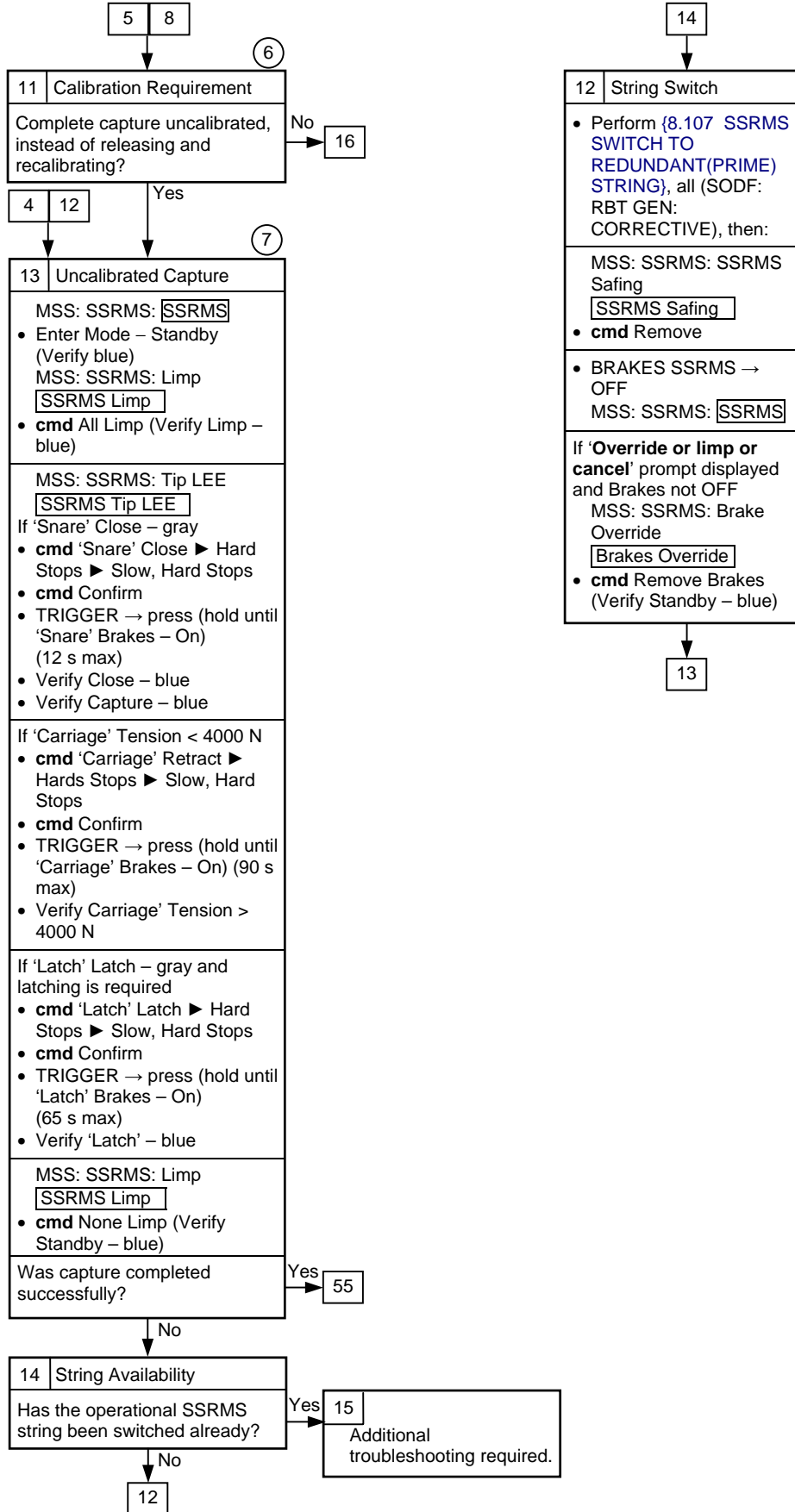

6 If calibration is lost, completing the capture to hardstops will result in loss of uncommanded derigidization monitoring. Also, if mating is required, checkpoint data must be reset. This procedure gives steps to do so.

7 A locked joint will not be limped if SSRMS is in Manual mode when All Limp command is issued (SCR 29341).

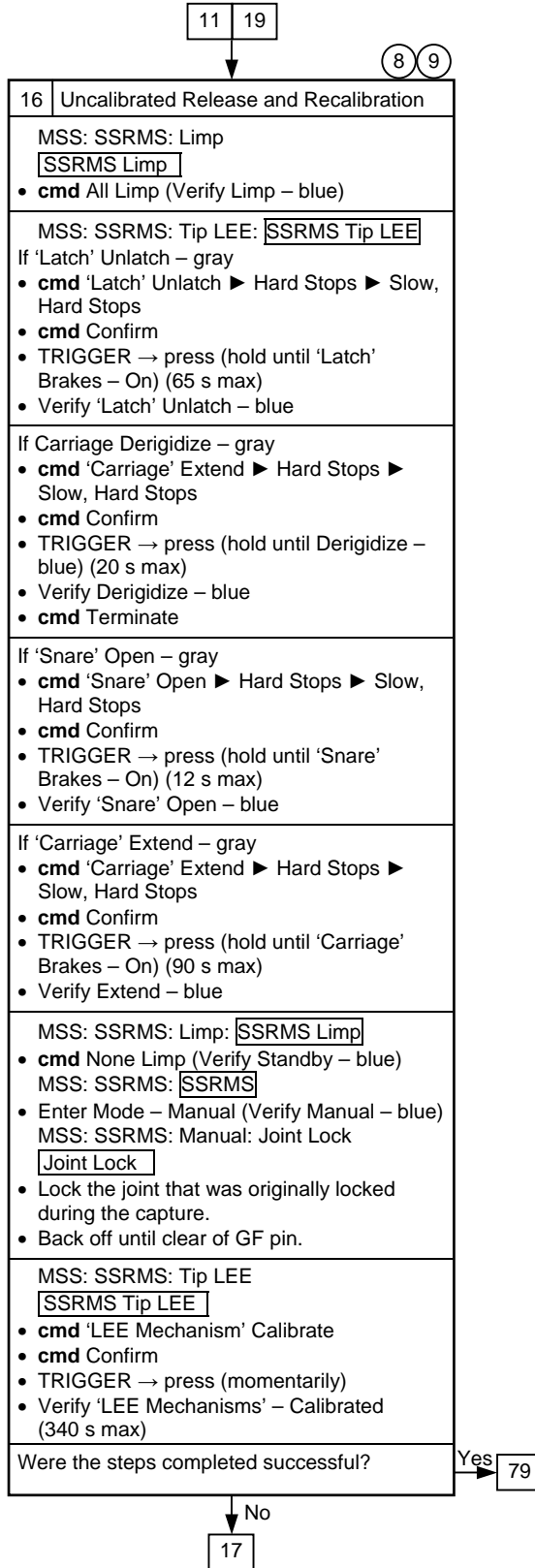

8
 A Calibrate command may be aborted by a 'SSRMS LEE LEU Mtr Velocity Runaway' Robotics Advisory message and the MSS safed if one of the three LEE mechanisms was initially located at the hardstop position. If safing occurs, cancel safing and command Calibrate again (SCR 20379).

9
 When extending until derigidize – blue, the trigger must be released once the derigidize indication turns blue.

7.510 SSRMS LEE CAPTURE FAILURE

(RBT GEN/X2R4 - ALL/FIN/SPN)

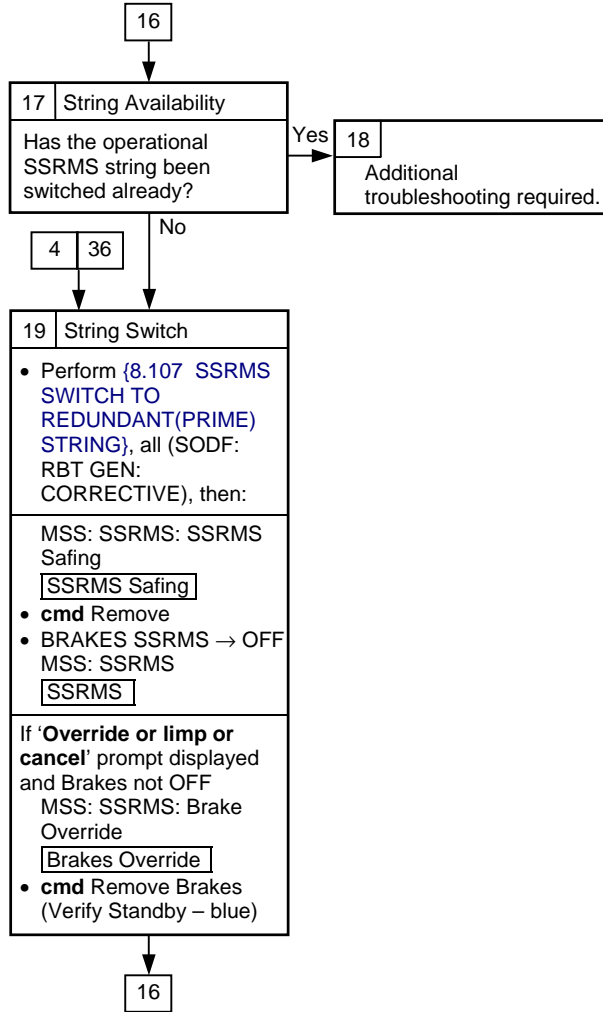

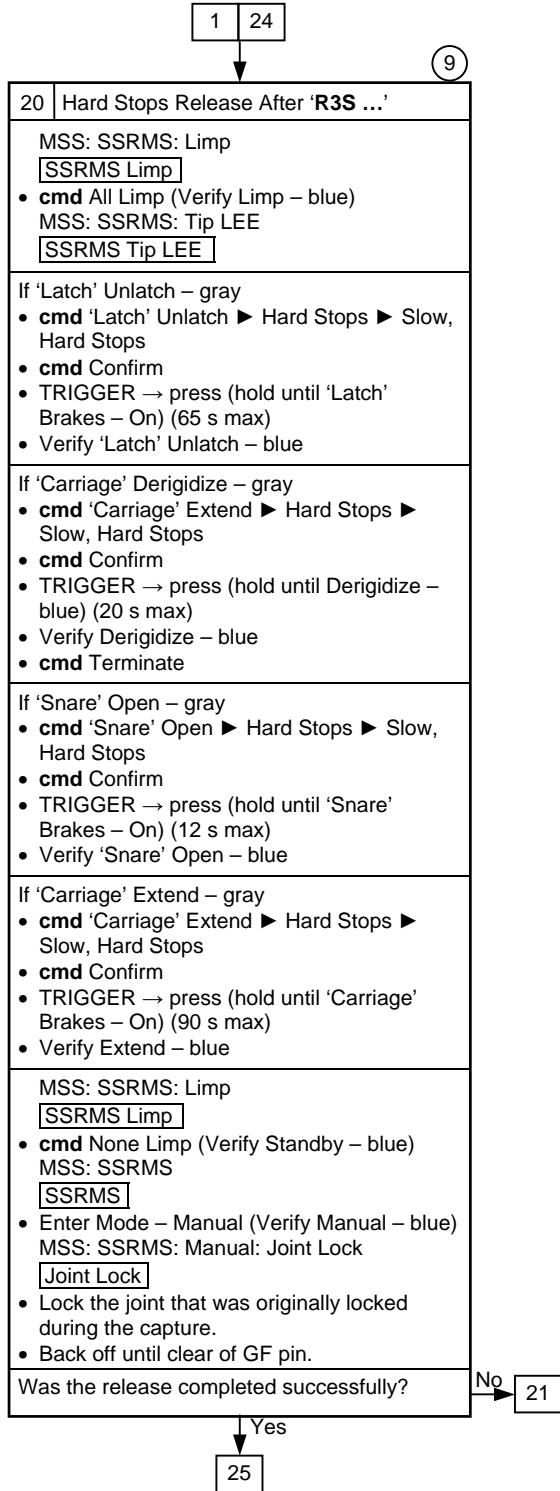

9
When extending until derigidize – blue, the trigger must be released once the derigidize indication turns blue.

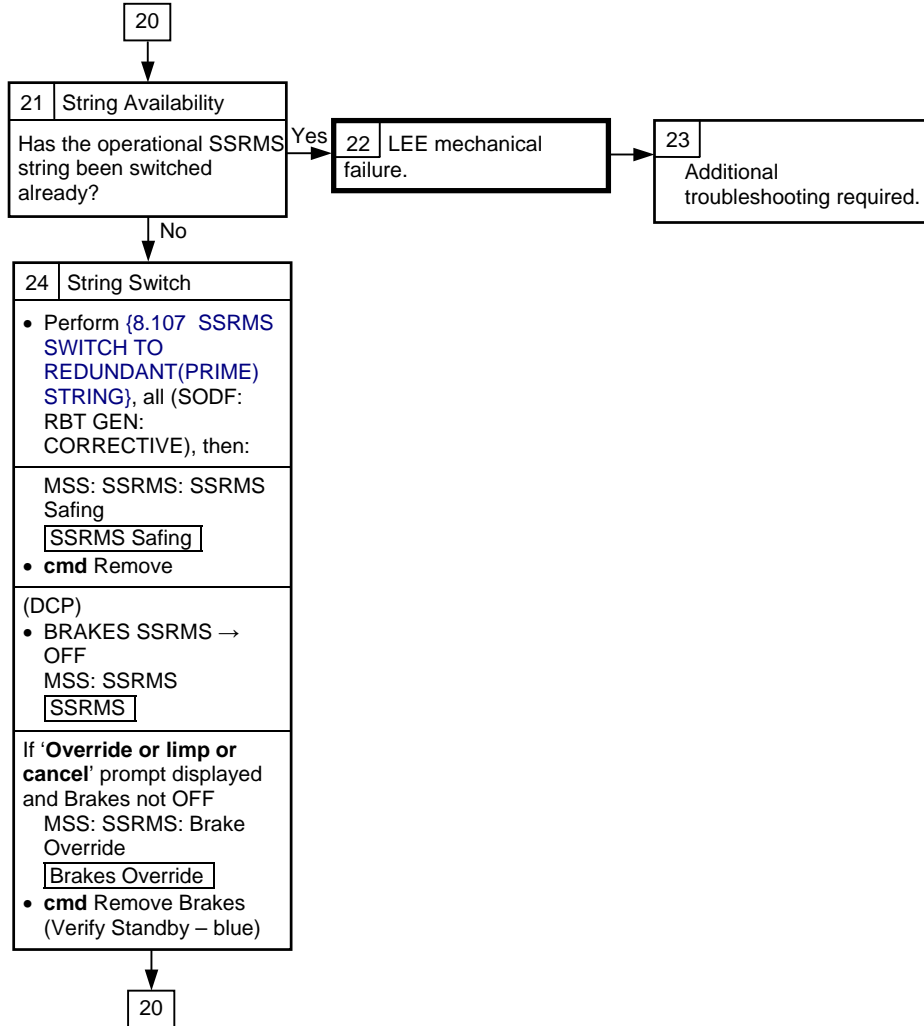

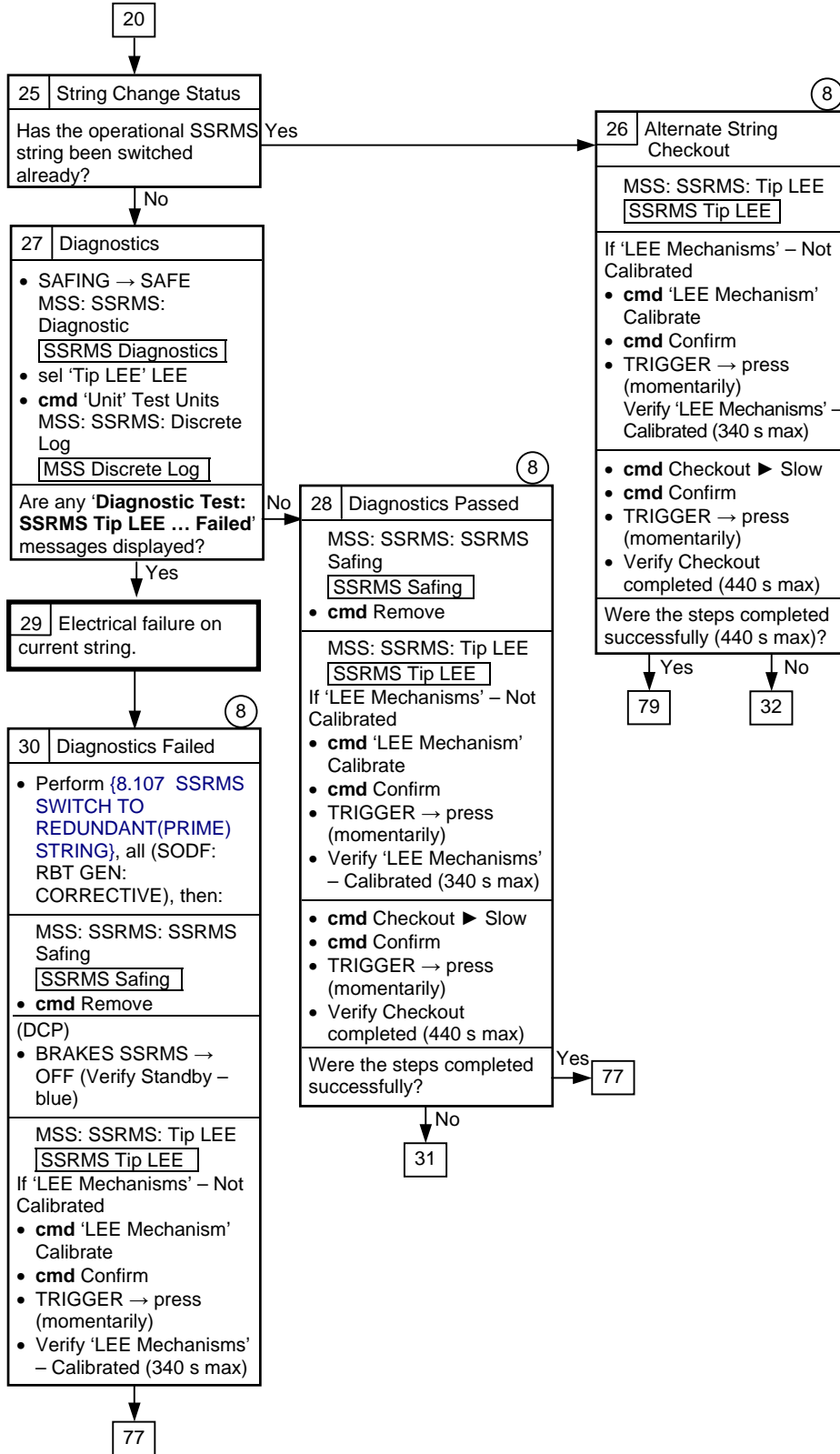

8 A Calibrate command may be aborted by a 'SSRMS LEE LEU Mtr Velocity Runaway' Robotics Advisory message and the MSS safed if one of the three LEE mechanisms was initially located at the hardstop position. If safing occurs, cancel safing and command Calibrate again (SCR 20379).

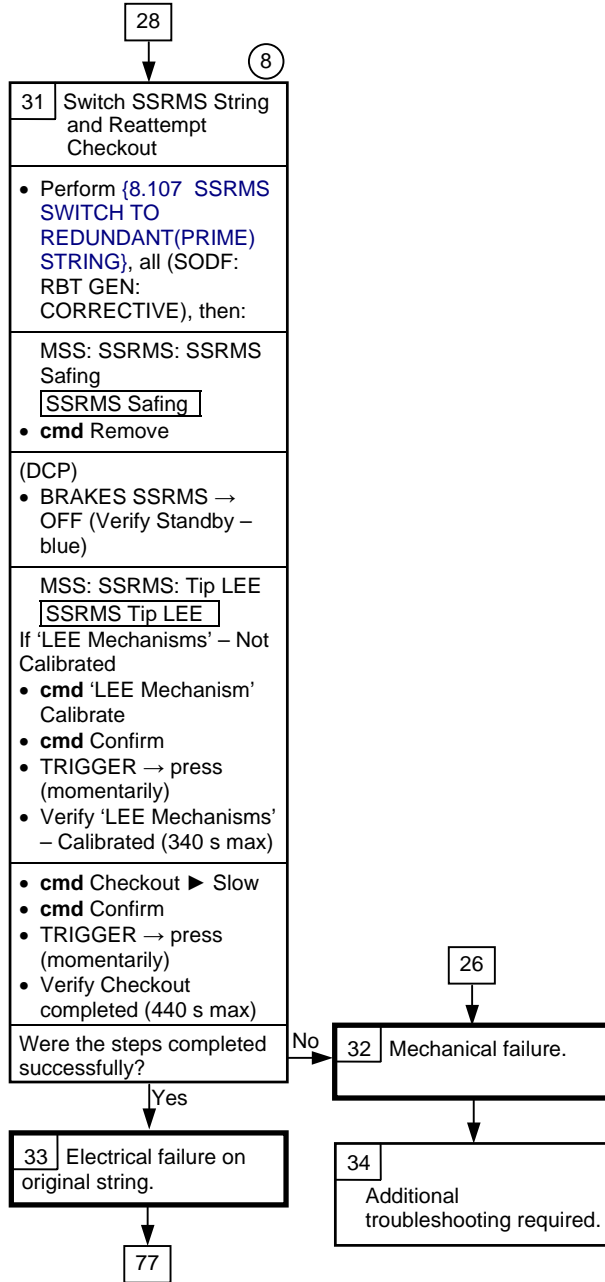

8
A Calibrate command may be aborted by a 'SSRMS LEE LEU Mtr Velocity Runaway' Robotics Advisory message and the MSS safed if one of the three LEE mechanisms was initially located at the hardstop position. If safing occurs, cancel safing and command Calibrate again (SCR 20379).

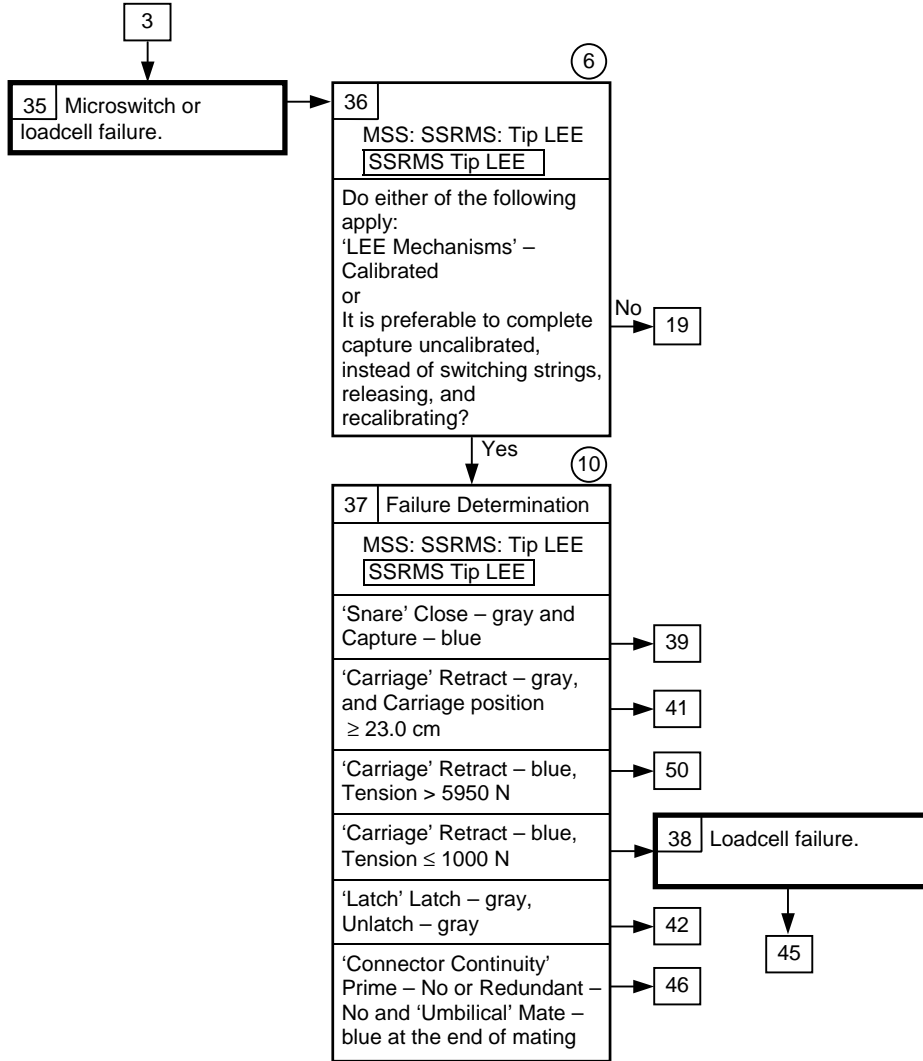

⑥ If calibration is lost, completing the capture to hardstops will result in loss of uncommanded derigidization monitoring. Also, if mating is required, checkpoint data must be reset.

⑩ The carriage position is only available on the ground.

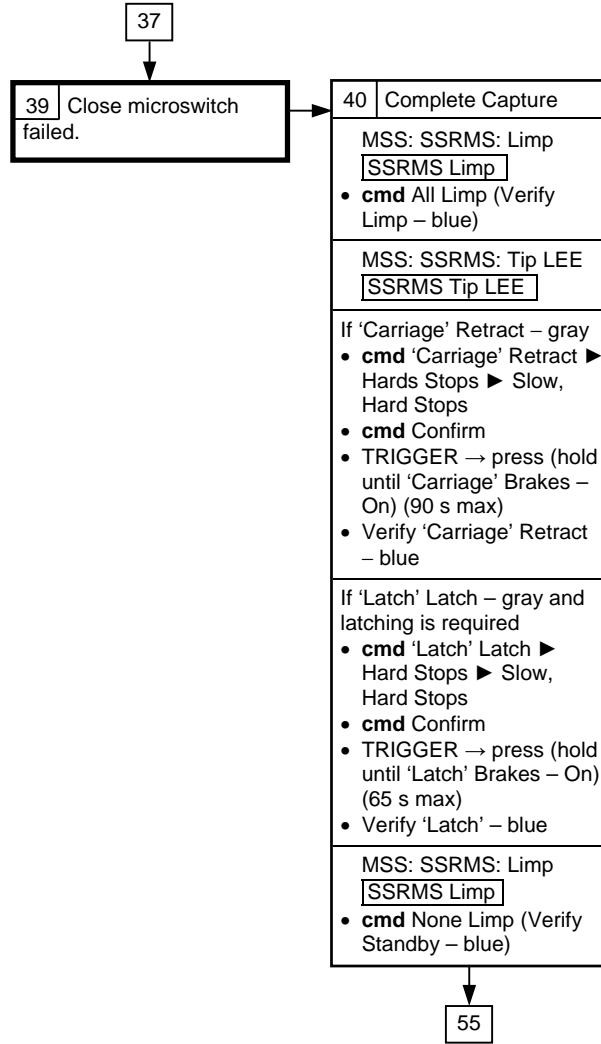

7.510 SSRMS LEE CAPTURE FAILURE

(RBT GEN/X2R4 - ALL/FIN/SPN)

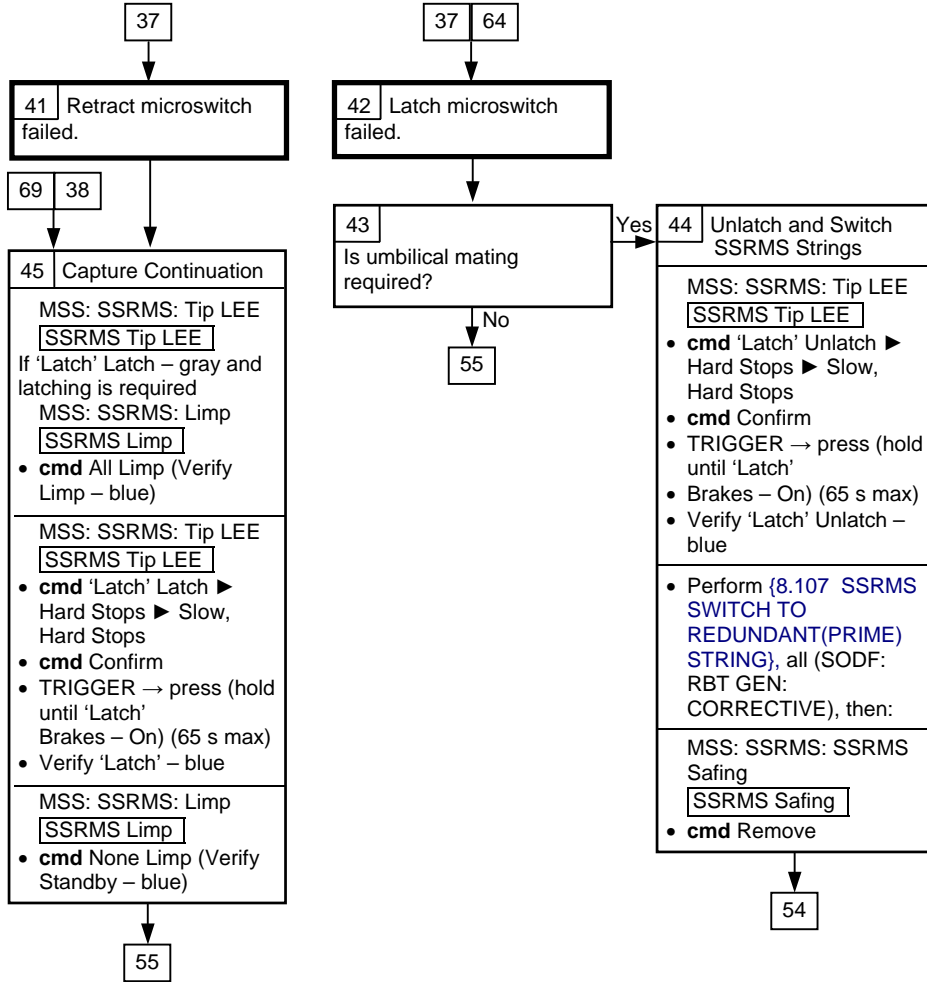

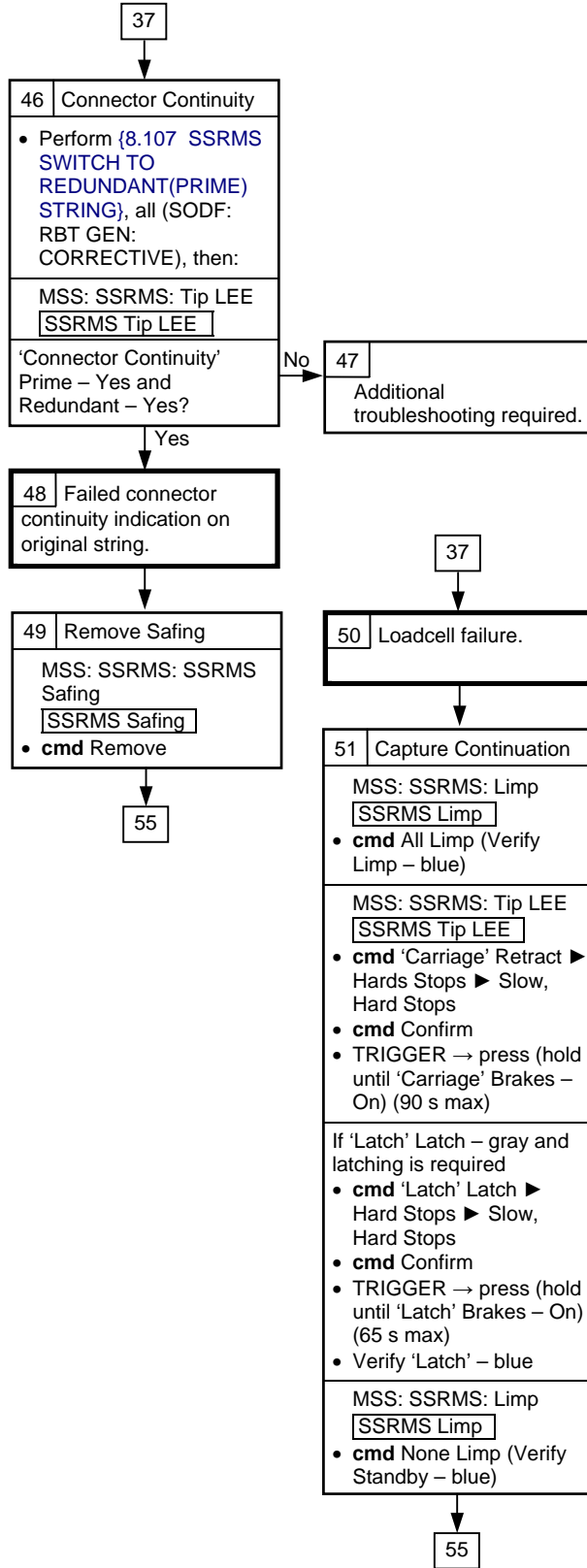

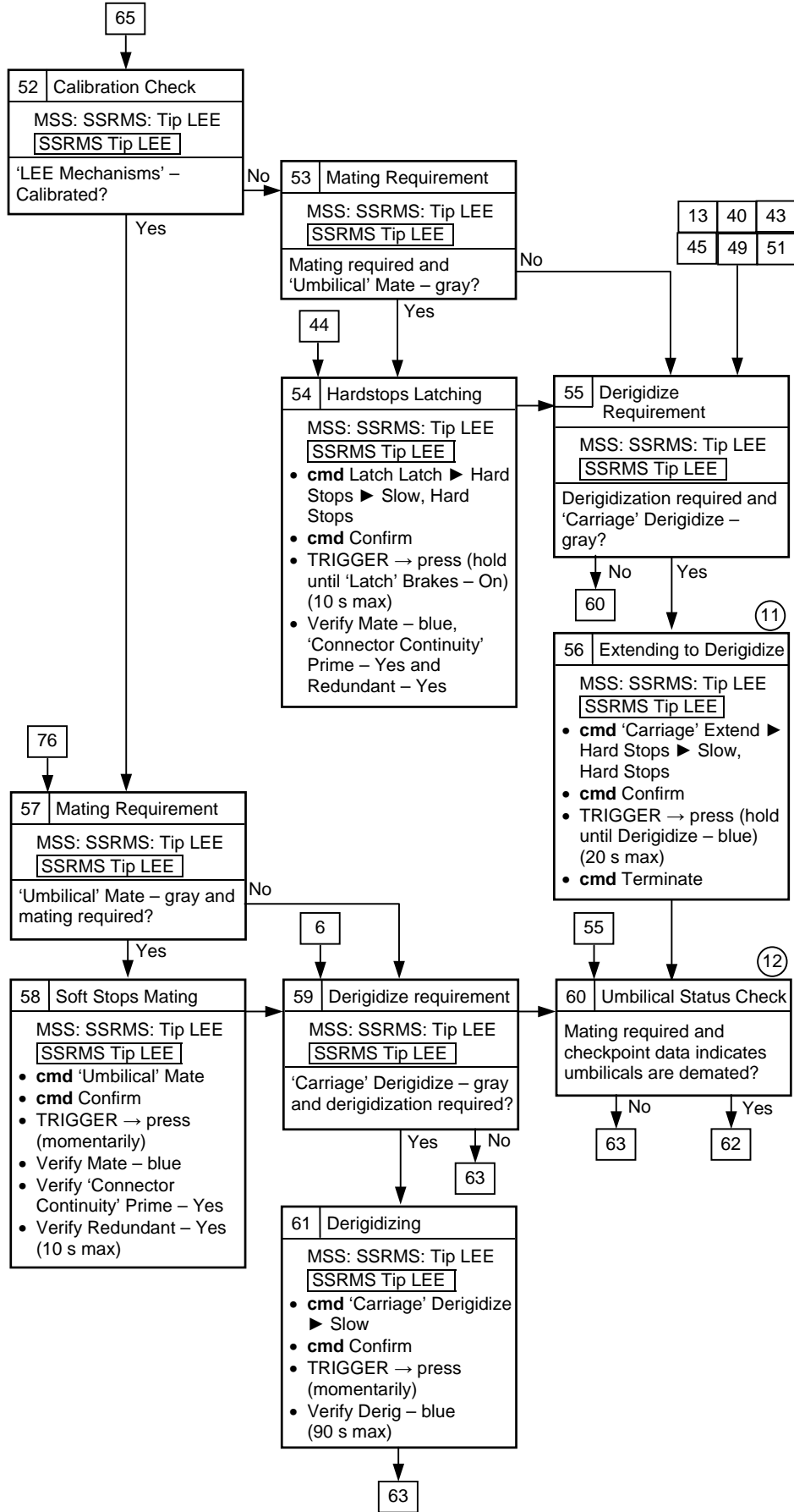

(11) When extending until Derigidize - blue, the trigger must be released once the derigidize indication turns blue. Fully extending the carriage while the SSRMS is braked may cause hardware damage.

(12) The UMB Status is only available on the ground.

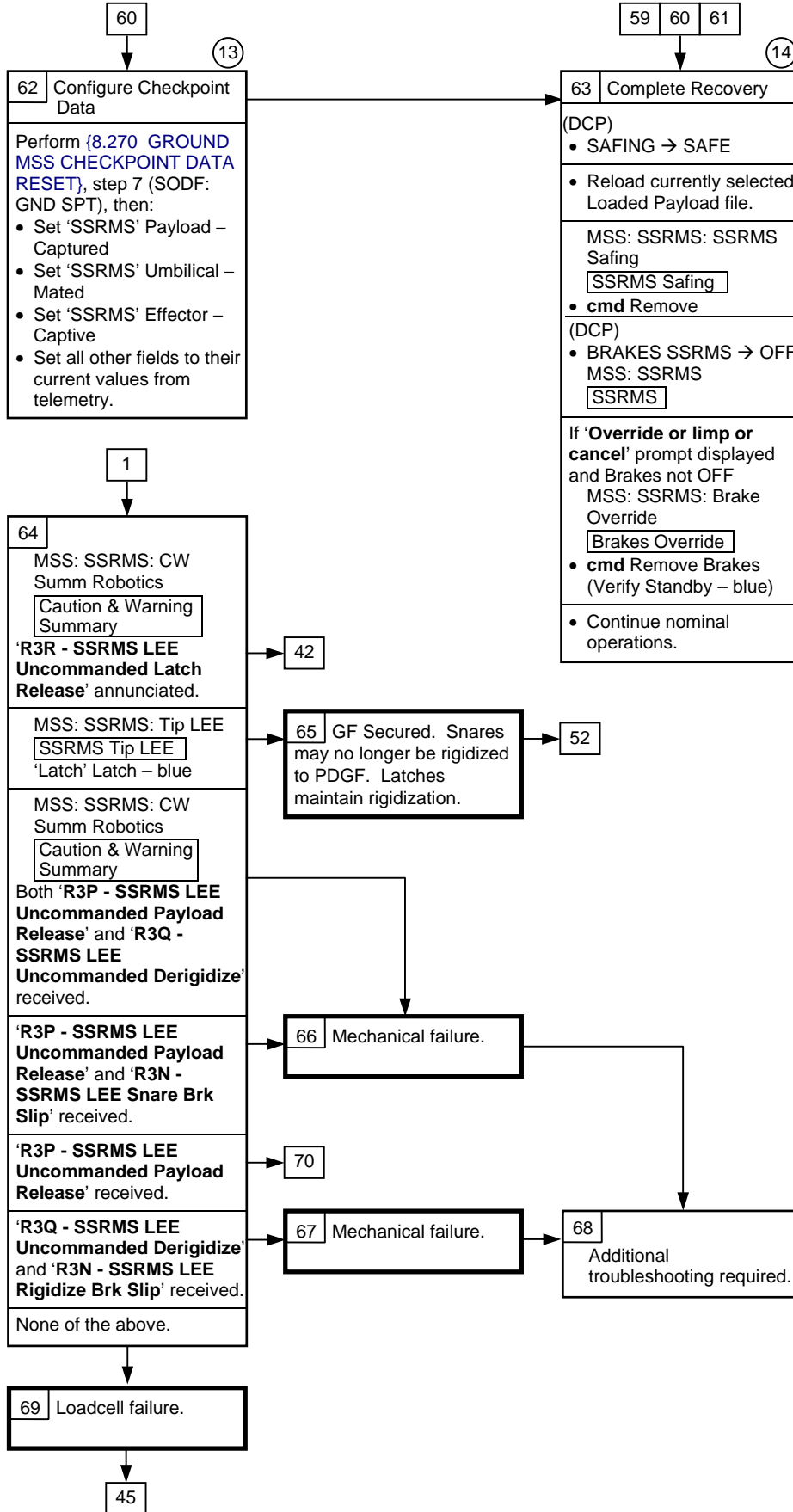

13 This step is performed by the ground.

14 Cycling safing is required to enable Uncommanded derigidization detection in the software. Reloading the loaded payload file is required to set the correct FOR in SACS for failed retract Microswitch scenarios. If the brake override was issued in this block, it will be required for all subsequent brake release operations until the payload is released.

64

70	Switch SSRMS Strings
<ul style="list-style-type: none"> Perform {8.107 SSRMS SWITCH TO REDUNDANT(PRIME) STRING}, all (SODF: RBT GEN: CORRECTIVE), then: 	
MSS: SSRMS: SSRMS Safing SSRMS Safing	
<ul style="list-style-type: none"> cmd Remove 	
(DCP)	
<ul style="list-style-type: none"> BRAKES SSRMS → OFF MSS: SSRMS SSRMS	
If 'Override or limp or cancel' prompt displayed and Brakes not OFF MSS: SSRMS: Brake Override Brakes Override	
<ul style="list-style-type: none"> cmd Remove Brakes (Verify Standby – blue) 	

9

71	Uncalibrated Release
MSS: SSRMS: Limp SSRMS Limp	
<ul style="list-style-type: none"> cmd All Limp (Verify Limp – blue) 	
MSS: SSRMS: Tip LEE: SSRMS Tip LEE	
If 'Latch' Unlatch – gray	
<ul style="list-style-type: none"> cmd 'Latch' Unlatch ▶ Hard Stops ▶ Slow, Hard Stops cmd Confirm TRIGGER → press (hold until 'Latch' Brakes – On) (65 s max) Verify 'Latch' Unlatch – blue 	
If Carriage Derigidize – gray	
<ul style="list-style-type: none"> cmd 'Carriage' Extend ▶ Hard Stops ▶ Slow, Hard Stops cmd Confirm TRIGGER → press (hold until Derigidize – blue) (20 s max) Verify Derigidize – blue cmd Terminate 	
If 'Snare' Open – gray	
<ul style="list-style-type: none"> cmd 'Snare' Open ▶ Hard Stops ▶ Slow, Hard Stops cmd Confirm TRIGGER → press (hold until 'Snare' Brakes – On) (12 s max) Verify 'Snare' Open – blue 	
If 'Carriage' Extend – gray	
<ul style="list-style-type: none"> cmd 'Carriage' Extend ▶ Hard Stops ▶ Slow, Hard Stops cmd Confirm TRIGGER → press (hold until 'Carriage' Brakes – On) (90 s max) Verify Extend – blue 	
MSS: SSRMS: Limp: SSRMS Limp	
<ul style="list-style-type: none"> cmd None Limp (Verify Standby – blue) MSS: SSRMS: SSRMS	
<ul style="list-style-type: none"> Enter Mode – Manual (Verify Manual – blue) MSS: SSRMS: Manual: Joint Lock Joint Lock	
<ul style="list-style-type: none"> Lock the joint that was originally locked during the capture. Back off until clear of GF pin. 	

9

When extending until derigidize – blue, the trigger must be released once the derigidize indication turns blue.

72

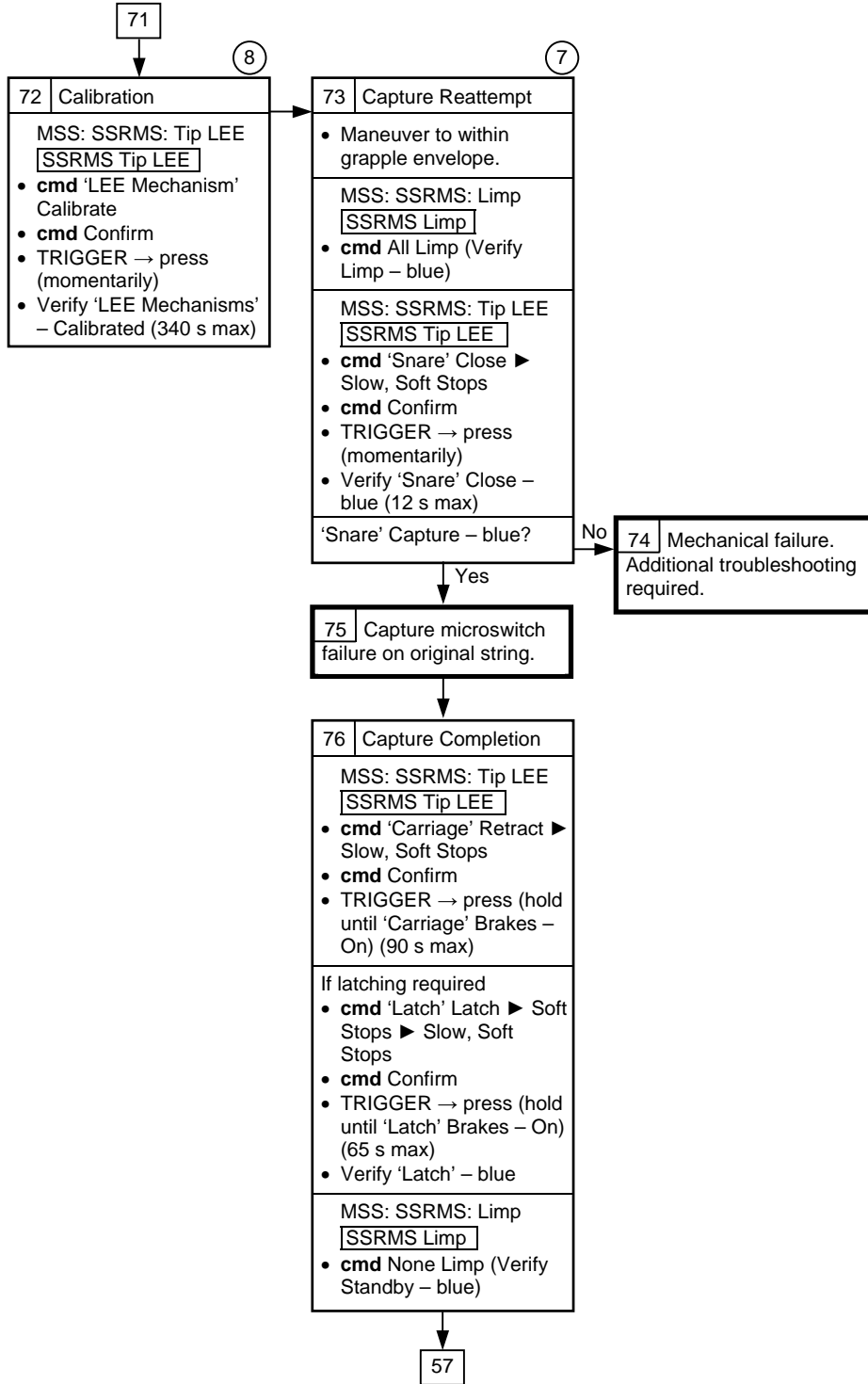

7 A locked joint will not be limped if SSRMS is in Manual mode when "All Limp" command is issued (SCR 29314).

8 A Calibrate command may be aborted by a 'SSRMS LEE LEU Mtr Velocity Runaway' Robotics Advisory message and the MSS safed if one of the three LEE mechanisms was initially located at the hardstop position. If safing occurs, cancel safing and command Calibrate again (SCR 20379).

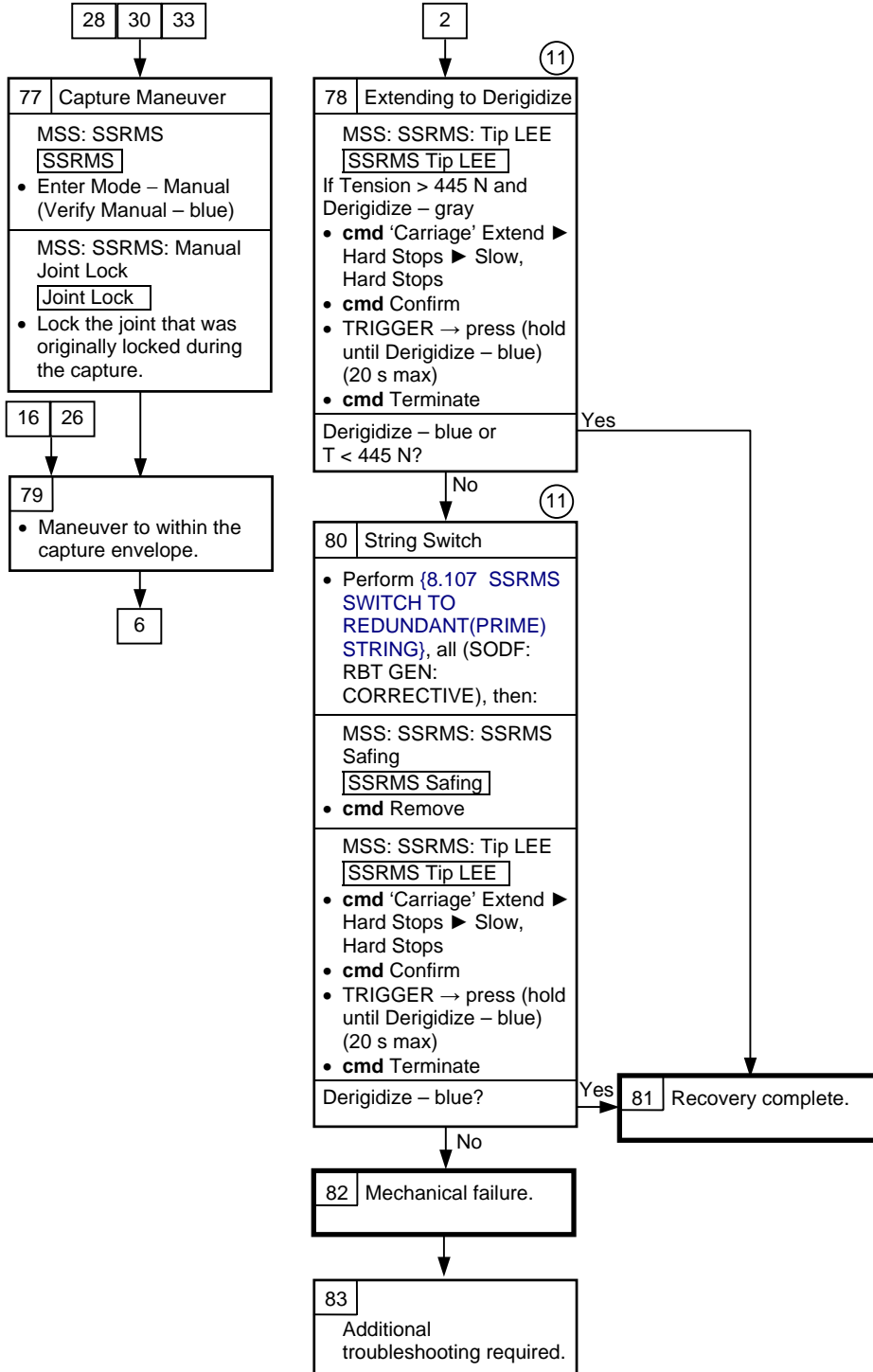

(11) When extending until Derigidize – blue, the trigger must be released once the derigidize indication turns blue. Fully extending the carriage while braking the SSRMS may cause hardware damage.

MSS

C&W
Robotics

7.701 MSS VIDEO FAILURE

(RBT GEN/X2R4 - ALL/FIN/SPN)

{7.001 MSS FAILURE RESPONSE AND RECOVERY},
block 135 (SODF: RBT GEN: MALFUNCTION)

①
Unless otherwise
indicated all displays
in this procedure are
on the PCS.

C&W messages
starting with
'R6...'

MSS Video
Route/Deroute
Failure, Loss of
Video, or
Degraded Video

①

1 Video Failure Signature

MSS: SSRMS: CW
Summ Robotics:
Caution & Warning
Summary

Any messages starting with
'R6...' currently in alarm.

Image degradation or loss
of video.

Route or deroute problem
to/from an RWS monitor.

46

2 Loss or degradation of
video image.

Lighting issues affecting the
image.

Image degradation not
related to lighting.

No video or frozen video.

12

18

36

Nominal Config:
DCP powered in
correct sequence.

Monitor brightness
and monitor viewing
angle appropriate.

CVIUs powered.

AVU is not powered.

Sync is enabled on
both channels to
the MSS VDUs.

3 Routing Status
Message

C&T:Video:
Video Overview
'Last Attempted Route'
'Status'

No path available

Invalid command

No MSS response

Video sw failure

SCU not active or no CSR
available

No status message

28

8

6

5 Video system issue.
No SCU currently active or
all EVSU 1 and 2 CSRs
currently in use.

40

4 DCP Camera Select
Button Checkout

(DCP)
While monitoring DCP
Status page on the PCS

- Depress and hold each
camera select button for
10 seconds.

MSS: LAS5(LAP5) DCP:
Lab (Cup) DCP Status
'Camera Select'

- Verify checkmark
appears for all buttons
when selected.

Checkmark appears for all
camera select buttons?

No

Yes

44

9

3

6 IVSU or EVSU Switch
failure. The ISVU/EVSU
sw configuration does not
match commanded.

7

- Coordinate with CATO
for troubleshooting the
USOS video system.

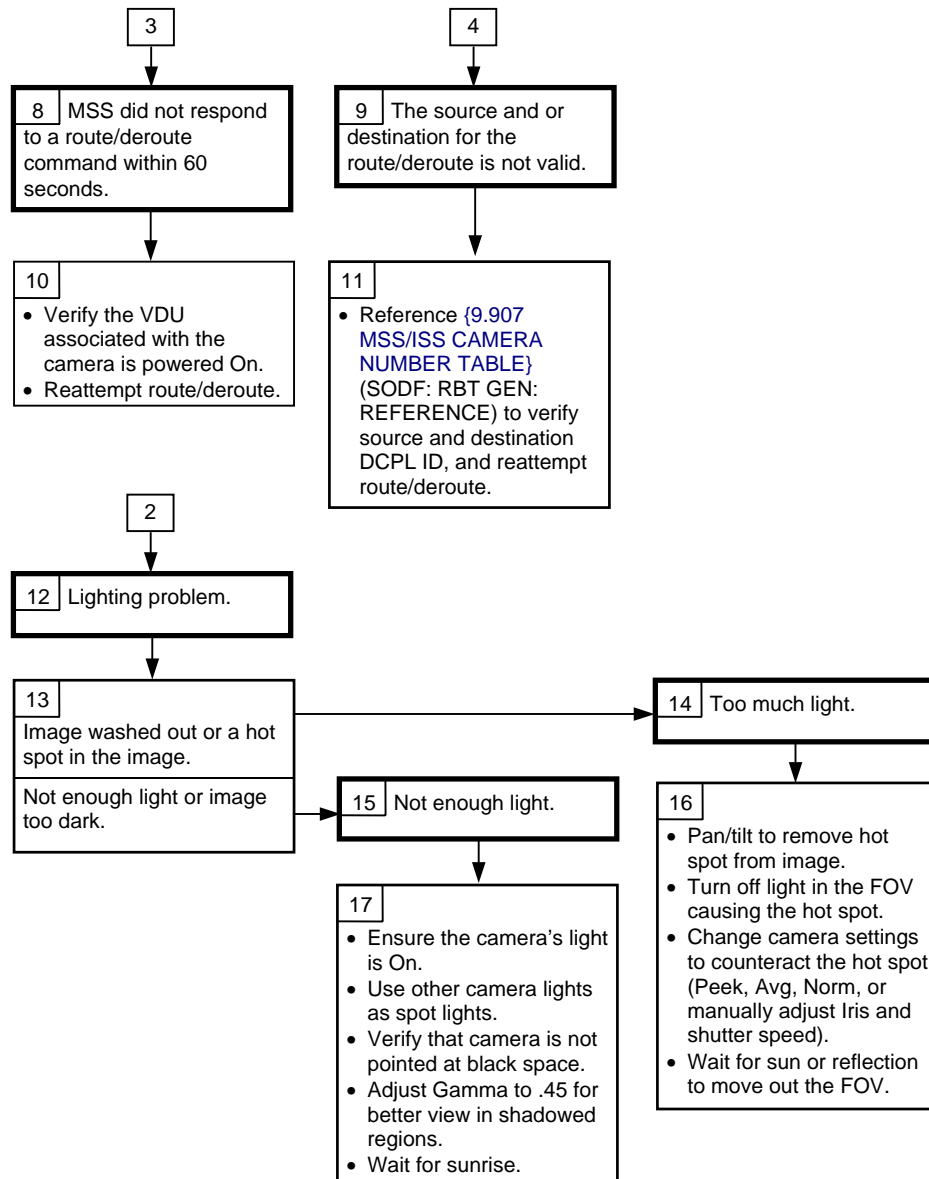

②
Power cycling the monitor or RWS may recover the monitor or VGC failure.

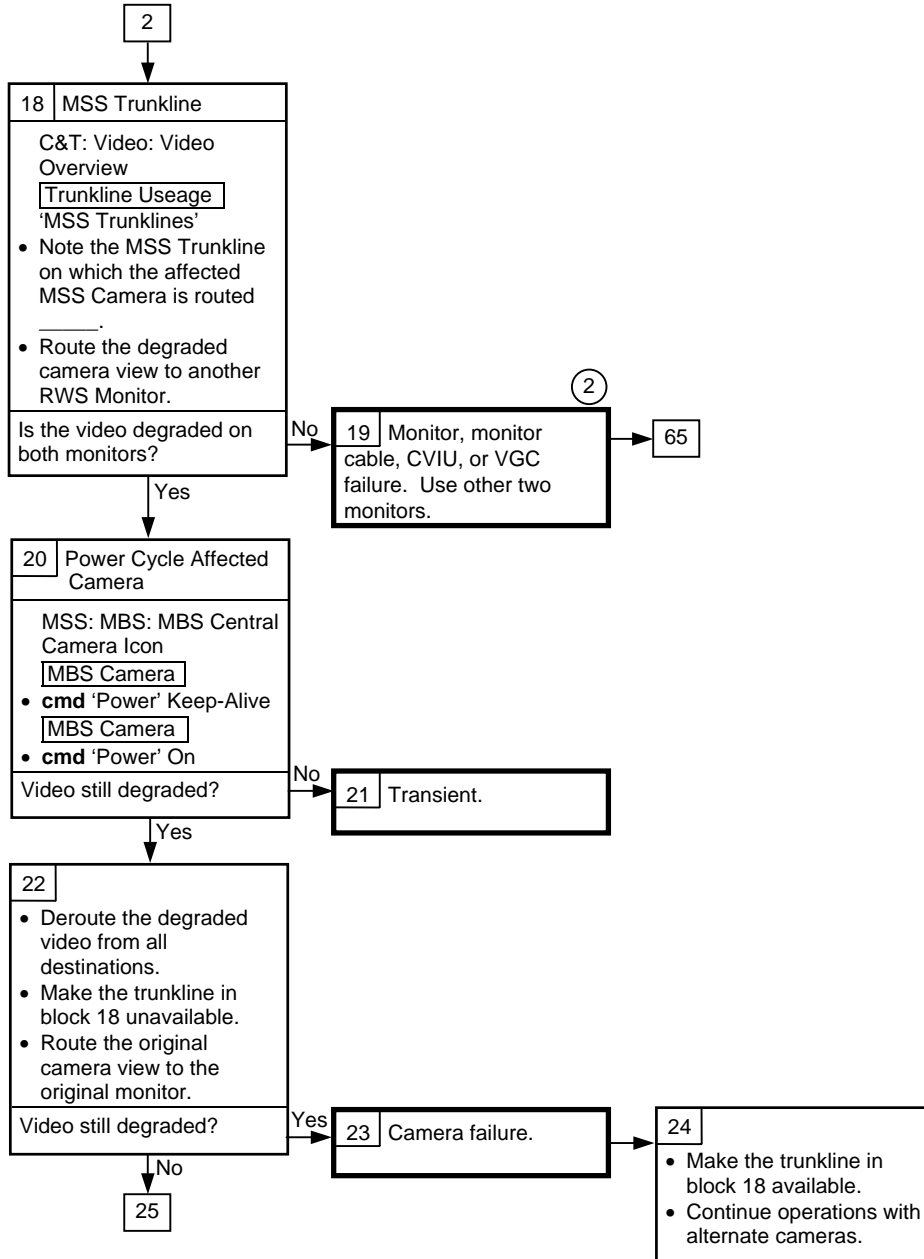

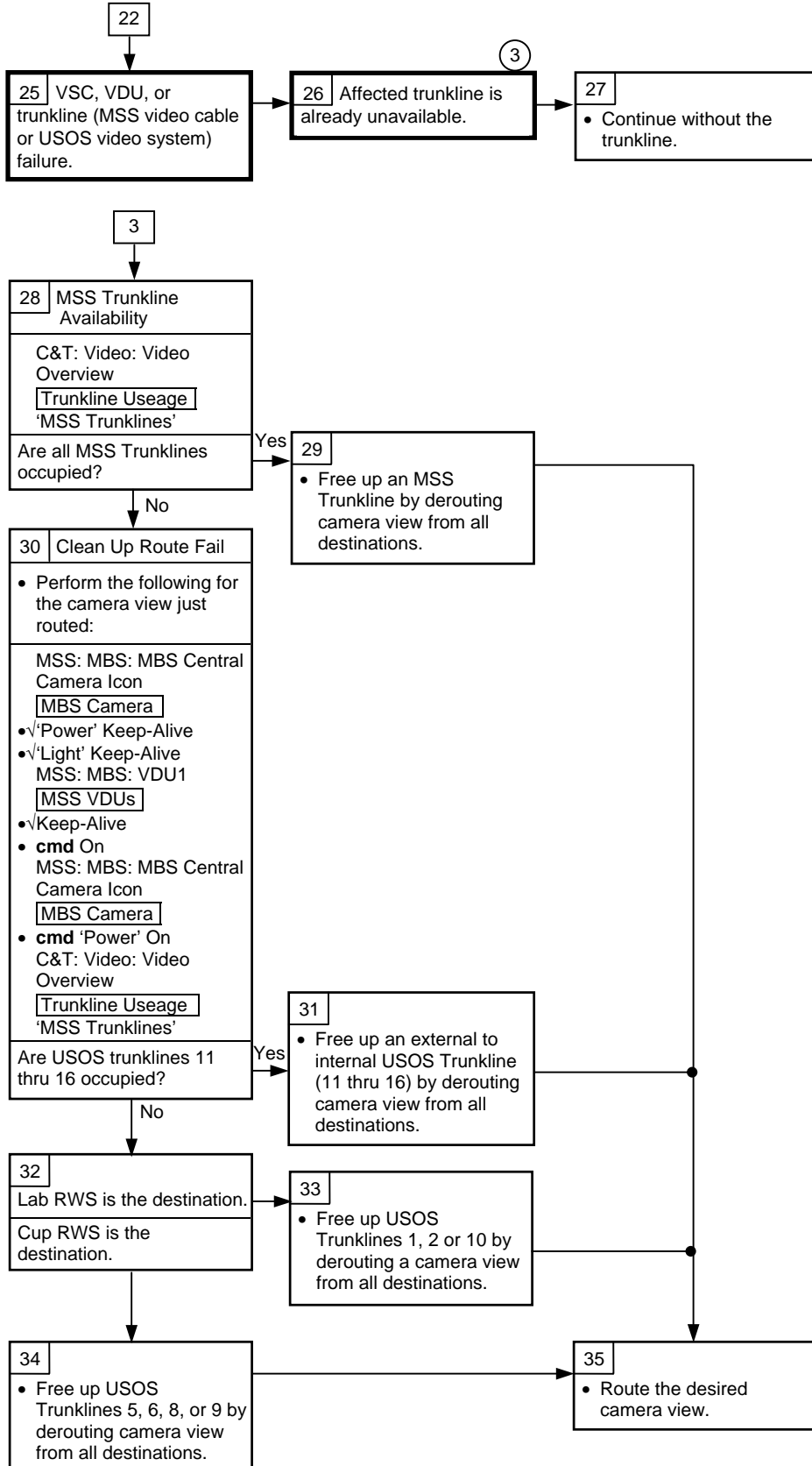

3 Power the affected VDU to Keep-Alive may recover the trunkline for upstream cameras.

Table 1.

Base = Lab DGF			Base = MBS PDGF 1 or 2			Base = MBS PDGF 3 or 4		
Camera	MS S T/L	→ EVSU	Camera	MSS T/L	→ EVSU	Camera	MSS T/L	→ EVSU
SSRMS Cameras	1 2 3	→ → →	SSRMS Cameras	4 6 9	→ → →	SSRMS Cameras	5 7 8	→ → →
		EVSU 3 EVSU 2 EVSU 1			EVSU 1 EVSU 2 EVSU 3			EVSU 1 EVSU 2 EVSU 3
MBS Camera	5	→ 1	MBS Camera	5	→ 1	MBS Camera	9	→ 3

④ VSC failure may affect multiple MSS Trunklines.

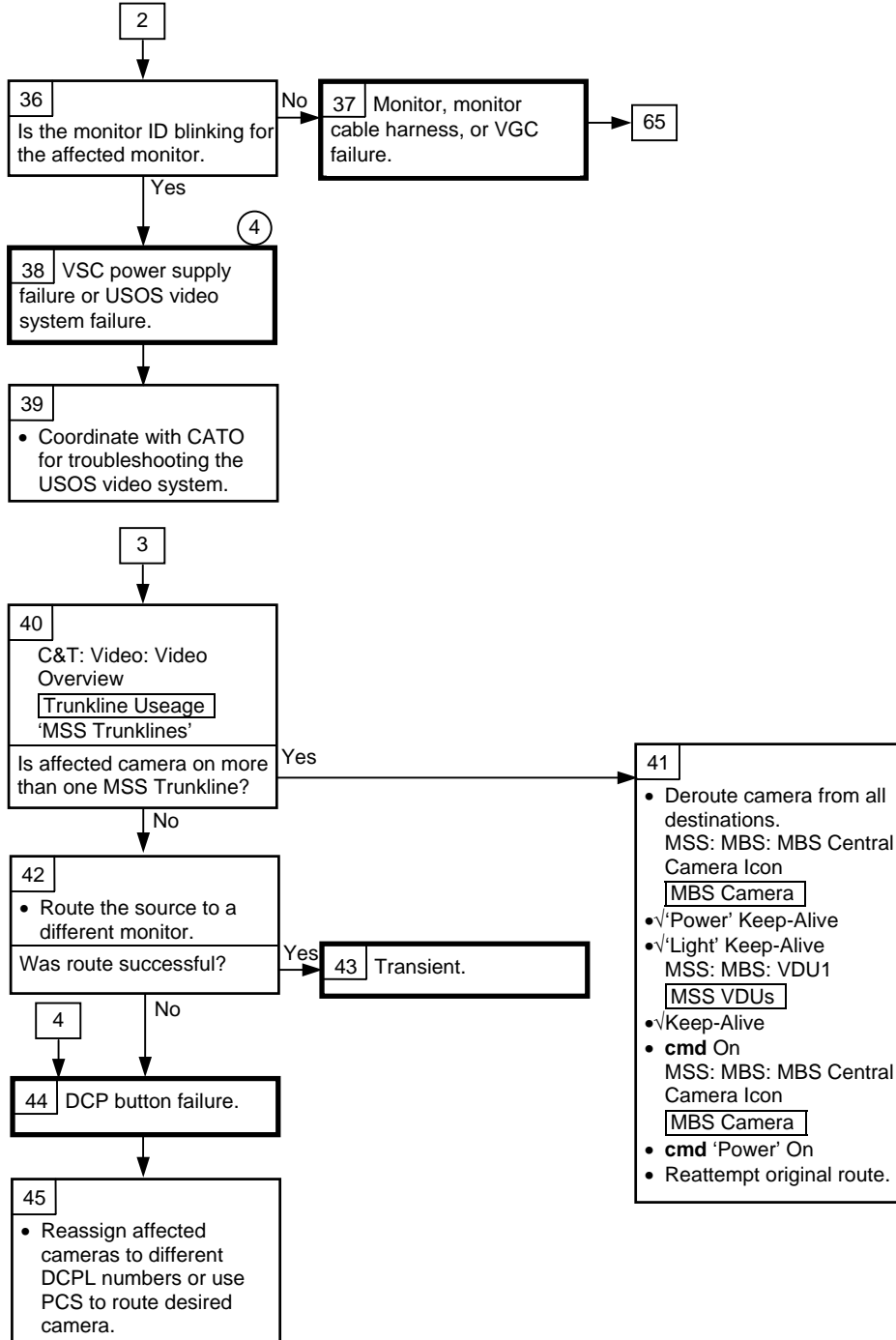

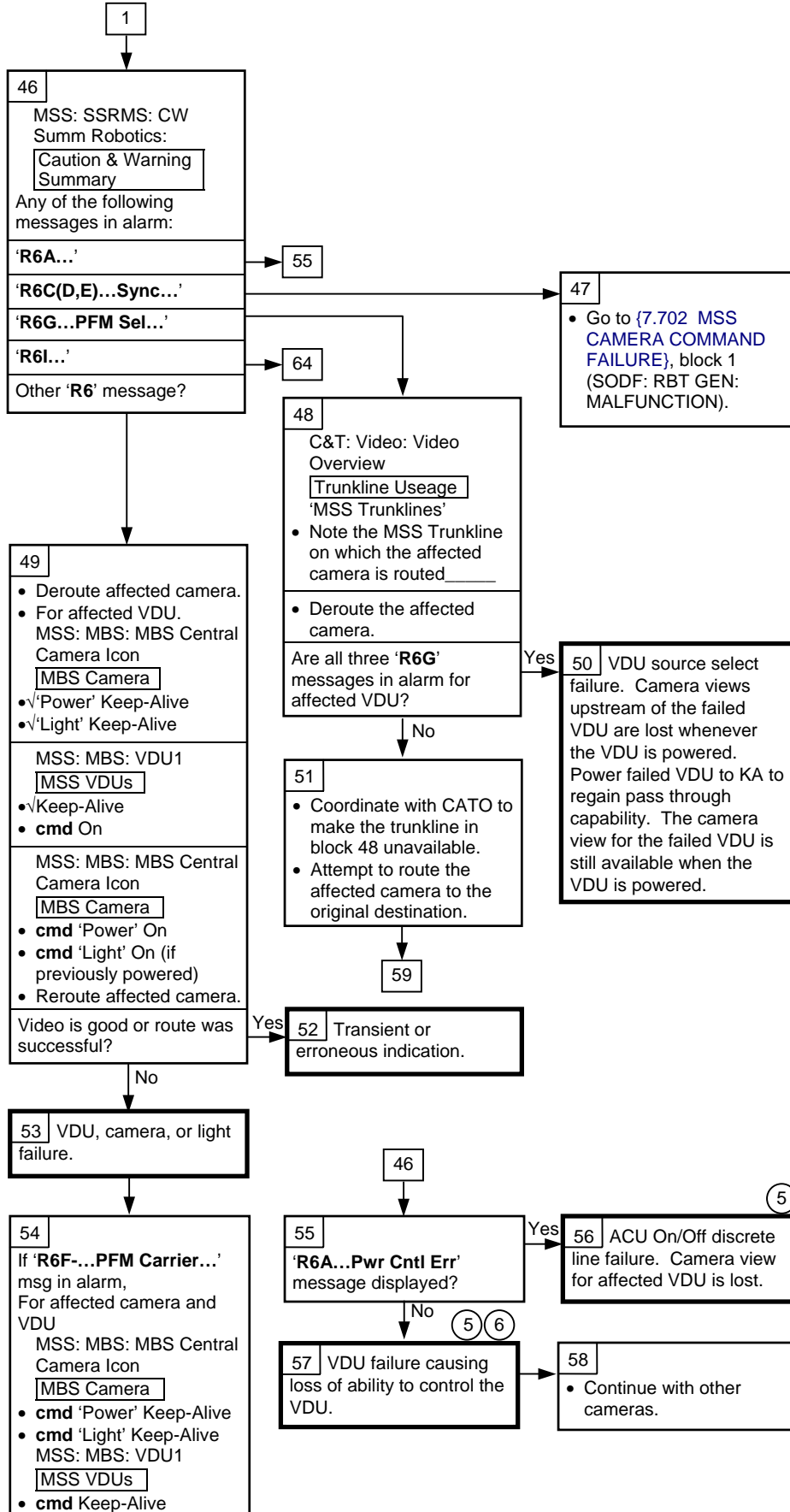

5 Switching SSRMS/MBS/POA strings or forcing the VDU to the alternate power source may recover the VDU.

6 The Camera view may remain and will still be controllable but will permanently occupy the current MSS trunkline until power is removed from the VDU.

7.701 MSS VIDEO FAILURE

(RBT GEN/X2R4 - ALL/FIN/SPN)

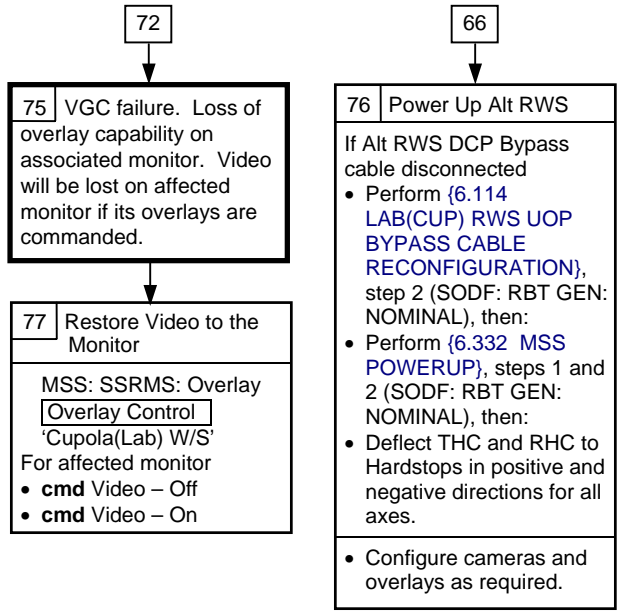

PCS 1. SETUP
MSS: SSRMS: Tip LEE:

√LEE Mechanisms – Calibrated

* If LEE Mechanisms not calibrated
* | Perform {6.421 LEE CALIBRATION}, all
* | (SODF: RBT GEN: NOMINAL), then:

√Setup – Yes

* If Setup – No
* | Perform {6.428 LEE SETUP FOR CAPTURE},
* | all (SODF: RBT GEN: NOMINAL), then:

Prior to beginning payload capture, review {SSRMS LEE CUE CARD}, all (SODF: RBT GEN: REFERENCE), then:

NOTE
The LEE Camera must be fully zoomed out to correspond to the target overlay.

Configure cameras and overlays for grapple.

MSS: SSRMS:

√Manual – blue

√Vernier

RHC/ 2. GRAPPLE MANEUVER
THC Maneuver to within grapple envelope.

PCS 3. LIMP SSRMS
MSS: SSRMS:

Enter Mode – Standby (Verify blue)

MSS: SSRMS: Limp:

cmd All Limp (Verify Limp – blue)

PCS MSS: SSRMS:

Verify all joints – Limped

PCS 4. CLOSE SNARES
MSS: SSRMS: Tip LEE:

cmd ‘Snare’ Close ► Slow, Soft Stops

8.101 MANUAL CAPTURE WITH CALIBRATED LEE

(RBT GEN/X2R4 - ALL/FIN 4/SPN) Page 2 of 4 pages

Verify Speed – Slow
Verify Stops – Soft
Verify '**Confirm or Terminate**' prompt.

CAUTION

Due to end-to-end system latency, the RHC Trigger is hot up to 3 seconds prior to receiving a Trigger Hot icon status on the PCS.

NOTE

Once the trigger is hot, only Safing or Trigger commands should be sent to the Robotics equipment. If a configuration change is required, including routing MSS cameras, safe the system to exit LEE operations (SCR 23262, 14662).

cmd Confirm (Verify RHC Trigger Hot icon)

Verify LEE Mode – Close Snares

RHC TRIGGER → press (hold until 'Snare' Brakes – On) (12 s(3 s) max)

PCS Verify 'Snare' Close, Capture (two) – blue

5. RETRACT CARRIAGE

PCS MSS: SSRMS: Tip LEE:

cmd 'Carriage' Retract ► Slow, Soft Stops

Verify Speed – Slow
Verify Stops – Soft
Verify '**Confirm or Terminate**' prompt.

cmd Confirm (Verify RHC Trigger Hot icon)

Verify LEE Mode – Retract Carriage

RHC TRIGGER → press (hold until 'Carriage' Brakes – On) (90 s(24 s) max)

PCS Verify 'Carriage' Retract – blue
Verify 'Carriage' Tension > 4003 N

6. LATCH

If grapple fixture is an FRGF or latching is not required, go to step 8.

MSS: SSRMS: Tip LEE:

cmd 'Latch' Latch ► Slow, Soft Stops

Verify Speed – Slow
Verify Stops – Soft
Verify '**Confirm or Terminate**' prompt.

8.101 MANUAL CAPTURE WITH CALIBRATED LEE

(RBT GEN/X2R4 - ALL/FIN 4/SPN) Page 3 of 4 pages

cmd Confirm (Verify RHC Trigger Hot icon)

Verify LEE Mode – Latch

RHC TRIGGER → press (hold until 'Latch' Brakes – On) (65 s(13 s) max)

Verify 'Latch' Latch – blue

7. MATE UMBILICALS

If mating of the umbilicals is required

PCS

MSS: SSRMS: Tip LEE:

cmd 'Umbilical' Mate (Verify '**Confirm or Terminate**' prompt)

NOTE

Expect '**R3L - SSRMS Pwr Flags Fail**' Robotics Advisory message when mating is complete (SCR 19019).

cmd Confirm (Verify RHC Trigger Hot icon)

Verify LEE Mode – Mate

RHC

TRIGGER → press (momentarily)

PCS

Verify 'Umbilical' Mate – blue (10 s max)

Verify 'Connector Continuity' Prime, Redundant (two) – Yes

8. DELIMP SSRMS

PCS

MSS: SSRMS: Limp:

cmd None Limp (Verify Standby – blue)

9. SSRMS DEADSTART CALIBRATION

NOTE

1. This step should only be performed if uncommanded Derig detection is required for the planned operations.
2. Expect the following message when safing is commanded:
**'R3Z - MSS OCS SSRMS Prime(Redun) ACU SRT
Cat-1 Brk Stat Fail'** (SCR 17495)
All messages should return to Norm.

DCP

SAFING → SAFE (Verify Safed)

PCS

MSS: SSRMS: SSRMS Safing:

cmd Remove (Verify – Not Safed)

DCP

SSRMS BRAKES → OFF (Verify OFF)

8.101 MANUAL CAPTURE WITH CALIBRATED LEE

(RBT GEN/X2R4 - ALL/FIN 4/SPN) Page 4 of 4 pages

10. DERIGIDIZE CARRIAGE

If derigidization of the carriage is not required >>

PCS

MSS: SSRMS: Tip LEE: SSRMS Tip LEE

cmd 'Carriage' Derigidize ► Slow (Verify Speed – Slow)

Verify '**Confirm or Terminate**' prompt.

cmd Confirm (Verify RHC Trigger Hot icon)

Verify LEE Mode – Derigidize

RHC

TRIGGER → press (momentarily) (SCR 19064)

PCS

Verify 'Carriage' Derigidize – blue (90 s max)

1. RETRACT CARRIAGE

PCS

MSS: SSRMS: Tip LEE:

If 'Latch' Latch – blue and 'Carriage' Retract – gray
cmd 'Carriage' Retract ► Hard Stops ► Slow, Hard Stops

Verify Speed – Slow
Verify Stops – Hard
Verify '**Confirm or Terminate**' prompt.

CAUTION

Due to end-to-end system latency, the RHC Trigger is hot up to 3 seconds prior to receiving a Trigger Hot icon status on the PCS.

NOTE

Once the trigger is hot, only safing or trigger commands should be sent to the Robotics equipment. If a configuration change is required, including routing MSS cameras, safe the system to exit LEE operations (SCR 23262, 14662).

cmd Confirm (Verify RHC Trigger Hot icon)

Verify LEE Mode – Retract Carriage

RHC

TRIGGER → press (hold until 'Carriage' Brakes – On) (90 s max)

Verify 'Carriage' Retract – blue

2. LIMP SSRMS AND ENTER MODE

PCS

MSS: SSRMS: Limp:

cmd All Limp (Verify Limp – blue)

MSS: SSRMS:

Verify All Joints – Limped

Wait 30 seconds.

MSS: SSRMS: Limp:

cmd None Limp (Verify Standby – blue)

Enter Mode – Manual (Verify blue)

√Vernier

8.103 MANUAL RELEASE WITH UNCALIBRATED LEE

(RBT GEN/E9 - ALL/FIN 5/SPN) Page 2 of 3 pages

3. DEMATE AND UNLATCH

If 'Latch' Latch – blue

cmd 'Latch' Unlatch ► Hard Stops ► Slow, Hard Stops

Verify Speed – Slow

Verify Stops – Hard

Verify '**Confirm or Terminate**' prompt.

CAUTION

Due to end-to-end system latency, the RHC Trigger is hot up to 3 seconds prior to receiving a Trigger Hot icon status on the PCS.

NOTE

Once the trigger is hot, only safing or trigger commands should be sent to the Robotics equipment. If a configuration change is required, including routing MSS cameras, safe the system to exit LEE operations (SCR 23262, 14662).

cmd Confirm (Verify RHC Trigger Hot icon)

Verify LEE Mode – Unlatch

RHC

TRIGGER → press (hold until 'Latch' Brakes – On) (65 s max)

Verify 'Latch' Unlatch – blue

4. DERIGIDIZE CARRIAGE

MSS: SSRMS: Tip LEE:

cmd 'Carriage' Extend ► Hard Stops ► Slow, Hard Stops

Verify Speed – Slow

Verify Stops – Hard

Verify '**Confirm or Terminate**' prompt.

CAUTION

Due to end-to-end system latency, the RHC Trigger is hot up to 3 seconds prior to receiving a Trigger Hot icon status on the PCS.

NOTE

Once the trigger is hot, only safing or trigger commands should be sent to the Robotics equipment. If a configuration change is required, including routing MSS cameras, safe the system to exit LEE operations (SCR 23262, 14662).

cmd Confirm (Verify RHC Trigger Hot icon)

Verify LEE Mode – Extend Carriage

8.103 MANUAL RELEASE WITH UNCALIBRATED LEE

(RBT GEN/E9 - ALL/FIN 5/SPN) Page 3 of 3 pages

CAUTION

The trigger must be released once the Derigidize indication turns blue. Failure to do so will cause the carriage to hit the grapple fixture cams, possibly causing hardware damage.

RHC TRIGGER → press (hold until 'Carriage' Derigidize – blue) (90 s max)

PCS **cmd** Terminate

5. OPEN SNARES

PCS MSS: SSRMS: Tip LEE:

cmd 'Snare' Open ► Hard Stops ► Slow, Hard Stops

Verify Speed – Slow

Verify Stops – Hard

Verify '**Confirm or Terminate**' prompt.

cmd Confirm (Verify RHC Trigger Hot icon)

Verify LEE Mode – Open Snares

RHC TRIGGER → press (hold until 'Snare' Brakes – On) (12 s max)

PCS Verify 'Snare' Open – blue

THC Back off from grapple fixture until clear of pin.

6. EXTEND CARRIAGE

PCS MSS: SSRMS: Tip LEE:

cmd 'Carriage' Extend ► Hard Stops ► Slow, Hard Stops

Verify Speed – Slow

Verify Stops – Hard

Verify '**Confirm or Terminate**' prompt.

cmd Confirm (Verify RHC Trigger Hot icon)

Verify LEE Mode – Extend Carriage

RHC TRIGGER → press (hold until 'Carriage' Brakes – On) (90 s max)

Verify 'Carriage' Extend – blue

This Page Intentionally Blank

1. SETUP

Prior to beginning payload capture, review {SSRMS LEE CUE CARD}, all (SODF: RBT GEN: REFERENCE), then:

NOTE
The LEE Camera must be fully zoomed out to correspond to the target overlay.

Configure cameras and overlays for grapple.

PCS

MSS: SSRMS:

- √Manual – blue
- √Vernier

2. GRAPPLE MANEUVER

RHC/
THC

Maneuver to within grapple envelope.

3. LIMP SSRMS

PCS

MSS: SSRMS:

Enter Mode – Standby (Verify blue)

MSS: SSRMS: Limp:

cmd All Limp (Verify Limp – blue)

PCS

MSS: SSRMS:

Verify all joints – Limped

4. CLOSE SNARES

MSS: SSRMS: Tip LEE:

cmd ‘Snare’ Close ► Hard Stops ► Slow, Hard Stops

- Verify Speed – Slow
- Verify Stops – Hard
- Verify ‘**Confirm or Terminate**’ prompt.

CAUTION
Due to end-to-end system latency, the RHC Trigger is hot up to 3 seconds prior to receiving a Trigger Hot icon status on the PCS.

NOTE
Once the trigger is hot, only safing or trigger commands should be sent to the Robotics equipment. If a configuration change is required, including routing MSS cameras, safe the system to exit LEE operations (SCR 23262, 14662).

cmd Confirm (Verify RHC Trigger Hot icon)

8.110 MANUAL CAPTURE WITH UNCALIBRATED LEE

(RBT GEN/E9 - ALL/FIN 4/SPN) Page 2 of 3 pages

Verify LEE Mode – Close Snares

RHC TRIGGER → press (hold until 'Snare' Brakes – On) (12 s max)

PCS Verify 'Snare' Close, Capture (two) – blue

5. RETRACT CARRIAGE

MSS: SSRMS: Tip LEE: SSRMS Tip LEE

cmd 'Carriage' Retract ► Hard Stops ► Slow, Hard Stops

Verify Speed – Slow

Verify Stops – Hard

Verify '**Confirm or Terminate**' prompt.

cmd Confirm (Verify RHC Trigger Hot icon)

Verify LEE Mode – Retract Carriage

RHC TRIGGER → press (hold until 'Carriage' Brakes – On) (90 s max)

PCS Verify 'Carriage' Retract – blue

6. LATCH

If grapple fixture is an FRGF or latching is not required, go to step 8.

MSS: SSRMS: Tip LEE: SSRMS Tip LEE

cmd 'Latch' Latch ► Hard Stops ► Slow, Hard Stops

Verify Speed – Slow

Verify Stops – Hard

Verify '**Confirm or Terminate**' prompt.

cmd Confirm (Verify RHC Trigger Hot icon)

Verify LEE Mode – Latch

RHC TRIGGER → press (hold until 'Latch' Latch – blue) (65 s max)

cmd Terminate

7. MATE UMBILICALS

If mating of the umbilicals is required

MSS: SSRMS: Tip LEE: SSRMS Tip LEE

cmd 'Latch' Latch ► Hard Stops ► Slow, Hard Stops

Verify Speed – Slow

Verify Stops – Hard

Verify '**Confirm or Terminate**' prompt.

8.110 MANUAL CAPTURE WITH UNCALIBRATED LEE

(RBT GEN/E9 - ALL/FIN 4/SPN) Page 3 of 3 pages

RHC

NOTE

Expect '**R3L - SSRMS Pwr Flags Fail**' Robotics Advisory message when mating is complete (SCR 19019).

cmd Confirm (Verify RHC Trigger Hot icon)

Verify LEE Mode – Latch

TRIGGER → press (hold until 'Latch' Brakes – On) (65 s max)

Verify 'Umbilical' Mate – blue

Verify 'Connector Continuity' Prime, Redundant (two) – Yes

8. DELIMP SSRMS

MSS: SSRMS: Limp: SSRMS Limp

cmd None Limp (Verify Standby – blue)

9. DERIGIDIZE CARRIAGE

If derigidization of the carriage is not required >>

MSS: SSRMS: Tip LEE: SSRMS Tip LEE

cmd 'Carriage' Extend ► Hard Stops ► Slow, Hard Stops

Verify Speed – Slow

Verify Stops – Hard

Verify '**Confirm or Terminate**' prompt.

cmd Confirm (Verify RHC Trigger Hot icon)

Verify LEE Mode – Extend Carriage

CAUTION

The trigger must be released once the derigidize indication turns blue. Failure to do so will cause the carriage to hit the grapple fixture cams, possibly causing hardware damage.

RHC TRIGGER → press (hold until 'Carriage' Derigidize – blue) (90 s max)

cmd Terminate

This Page Intentionally Blank

8.209 MT TUS CABLE CUT

(RBT GEN/ULF1 - ALL/FIN 1)

Page 1 of 3 pages

NOTE

The RPC position PUIs on the MT TUS1 Cut and MT TUS2 Cut displays are incorrect. **MCC-H** can provide a path to appropriate EPS displays in order to determine the correct RPC position status (SCR 31577).

1. VERIFICATION

PCS

MSS: MT: MT Mode:

Verify SEPS Process State – Initiated

MSS: MT: Power:

If failed cable – TUS1

√'TUS2' RPCM S0-3A-E RPC 18 – Cl

√'TUS1' RPCM S0-4B-F RPC 17 – Op

sel RPCM S0-4B-F RPC 17

cmd Close Cmd inhibit (Verify – Inh)

Go to step 2.

If failed cable – TUS2

√'TUS1' RPCM S0-4B-F RPC 17 – Cl

√'TUS2' RPCM S0-3A-E RPC 18 – Op

sel RPCM S0-3A-E RPC 18

cmd Close Cmd inhibit (Verify – Inh)

Go to step 3.

2. TUS1 CUT

2.1 TUS1 Cable Cutter Relay A Power

MSS: MT: TUS1 Cut: RPCM MT3A RPC 03:

cmd 'RPC Position' – Close (Verify – Cl)

2.2 TUS1 Cable Cutter Relay B Power

MSS: MT: TUS1 Cut: RPCM MT3A RPC 06:

cmd 'RPC Position' – Close (Verify – Cl)

2.3 TUS1 Cable Cut

CAUTION

The following step will sever the TUS1 Cable.

8.209 MT TUS CABLE CUT

(RBT GEN/ULF1 - ALL/FIN 1) Page 2 of 3 pages

MSS: MT: TUS1 Cut: RPCM MT3A RPC 17:

RPCM MT3A A RPC 17

cmd 'RPC Position' – Close (Verify – Cl)

2.4 TUS1 Cable Cutter Unpower

cmd 'RPC Position' – Open (Verify – Op)

2.5 TUS1 Cable Cutter Relay B Unpower

MSS: MT: TUS1 Cut: RPCM MT3A RPC 06:

RPCM MT3A A RPC 06

cmd 'RPC Position' – Open (Verify – Op)

2.6 TUS1 Cable Cutter Relay A Unpower

MSS: MT: TUS1 Cut: RPCM MT3A RPC 03:

RPCM MT3A RPC 03

cmd 'RPC Position' – Open (Verify – Op) >>

3. TUS2 CUT

3.1 TUS2 Cable Cutter Relay A Power

MSS: MT: TUS2 Cut: RPCM MT4B RPC 03:

RPCM MT4B A RPC 03

cmd 'RPC Position' – Close (Verify – Cl)

3.2 TUS2 Cable Cutter Relay B Power

MSS: MT: TUS2 Cut: RPCM MT4B RPC 06:

RPCM MT4B A RPC 06

cmd 'RPC Position' – Close (Verify – Cl)

3.3 TUS2 Cable Cut

CAUTION

The following step will sever the TUS2 Cable.

MSS: MT: TUS2 Cut: RPCM MT4B RPC 17:

RPCM MT4B A RPC 17

cmd 'RPC Position' – Close (Verify – Cl)

3.4 TUS2 Cable Cutter Unpower

cmd 'RPC Position' – Open (Verify – Op)

3.5 TUS2 Cable Cutter Relay B Unpower

MSS: MT: TUS2 Cut: RPCM MT4B RPC 06:

RPCM MT4B A RPC 06

8.209 MT TUS CABLE CUT

(RBT GEN/ULF1 - ALL/FIN 1) Page 3 of 3 pages

cmd 'RPC Position' – Open (Verify – Op)

3.6 TUS2 Cable Cutter Relay A Unpower

MSS: MT: TUS2 Cut: RPCM MT4B RPC 03:

RPCM MT4B A RPC 03

cmd 'RPC Position' – Open (Verify – Op)

This Page Intentionally Blank

8.306 MBS REBOOT PRIME(REDUNDANT) STRING

(RBT GEN/X2R4 - ALL/FIN 1) Page 1 of 2 pages

I

NOTE
POA must not be Operational.

PCS 1. [SETUP](#)
MSS: MBS:

√'MBS Safing' – Safed

2. [TRANSITION MBS PRIME\(REDUNDANT\) STRING TO OFF](#)

NOTE

1. If SSRMS is based on MBS, it must be Off on commanded string.
2. Expect the following Caution and Warning messages while performing the next command:
'R1E - MSS Active OCS MBS Prime(Redun) MCU SRT Comm Fail' (SCR 17730)

PCS MSS: MBS: MCU:

cmd 'Prime(Redundant)' Off (Verify – Off) (30 s max)

3. [TRANSITION MBS PRIME\(REDUNDANT\) STRING FROM OFF TO KEEP-ALIVE](#)

cmd '(Prime)Redundant' Keep-Alive (Verify – Keep-Alive) (30 s max)

4. [TRANSITION MBS PRIME\(REDUNDANT\) STRING FROM KEEP-ALIVE TO OPERATIONAL](#)

NOTE

1. The transition from Keep-Alive to Operational can be stopped at any time by issuing a Safing command.
2. The MBS transition from Keep-Alive to Operational will require approximately 3 minutes. The time is contingent on file transfer activity from the C&C MDM.
3. If the alternate string is Off while the MBS is Operational, expect the following Robotics Advisory messages:
'R20 - MSS MBS CRPCM 1R(1P) Cat-2 Transmit Msg Err'
'R20 - MSS MBS CRPCM 2R(2P) Cat-2 Transmit Msg Err'
'R20 - MSS MBS CRPCM 3R(3P) Cat-2 Transmit Msg Err'
'R20 - MSS MBS CRPCM 1R(1P) Cat-2 Receive Msg Err'
'R20 - MSS MBS CRPCM 2R(2P) Cat-2 Receive Msg Err'
'R20 - MSS MBS CRPCM 3R(3P) Cat-2 Receive Msg Err'
(SCR 21744)

cmd 'Prime(Redundant)' Operational (Verify Systems State – Operational)

8.306 MBS REBOOT PRIME(REDUNDANT) STRING

(RBT GEN/X2R4 - ALL/FIN 1) Page 2 of 2 pages

5. MBS VIDEO COMPONENTS POWERUP

PCS

MSS: MBS: VDU1:

sel '[X]' where [X] =
√'Primary','Redundant' Keep-Alive
Repeat

NOTE

Expect '**R6F - MBS... PFM Carrier On Video 1 Err**' Robotics Advisory message as each VDU is powered on. Message may toggle in and out of alarm until video is routed to the defined VDU (SCR 24376).

sel '[X]' as required where [X] =
cmd On (Verify – On)
Repeat

MSS: MBS: MBS Central Camera icon:

sel [X] as required where [X] =
cmd 'Power' On (Verify – On)
Repeat

6. MBS VIDEO DEROUTING

MSS: Video:

Repeat the following for all destinations to which an MBS Camera is routed:

sel 'Destination Icon'

cmd 'Deroute Video Signal' – Deroute