

NASA/CR-2007-213697

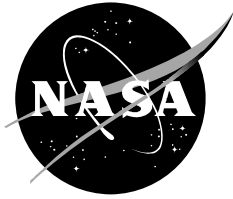

Lessons Learned From Seven Space Shuttle Missions

John Goodman
United Space Alliance
Houston, Texas 77058

January 2007

THE NASA STI PROGRAM OFFICE . . . IN PROFILE

Since its founding, NASA has been dedicated to the advancement of aeronautics and space science. The NASA Scientific and Technical Information (STI) Program Office plays a key part in helping NASA maintain this important role.

The NASA STI Program Office is operated by Langley Research Center, the lead center for NASA's scientific and technical information. The NASA STI Program Office provides access to the NASA STI Database, the largest collection of aeronautical and space science STI in the world. The Program Office is also NASA's institutional mechanism for disseminating the results of its research and development activities. These results are published by NASA in the NASA STI Report Series, which includes the following report types:

- **TECHNICAL PUBLICATION.** Reports of completed research or a major significant phase of research that present the results of NASA programs and include extensive data or theoretical analysis. Includes compilations of significant scientific and technical data and information deemed to be of continuing reference value. NASA's counterpart of peer-reviewed formal professional papers but has less stringent limitations on manuscript length and extent of graphic presentations.
- **TECHNICAL MEMORANDUM.** Scientific and technical findings that are preliminary or of specialized interest, e.g., quick release reports, working papers, and bibliographies that contain minimal annotation. Does not contain extensive analysis.
- **CONTRACTOR REPORT.** Scientific and technical findings by NASA-sponsored contractors and grantees.

- **CONFERENCE PUBLICATION.** Collected papers from scientific and technical conferences, symposia, seminars, or other meetings sponsored or cosponsored by NASA.
- **SPECIAL PUBLICATION.** Scientific, technical, or historical information from NASA programs, projects, and mission, often concerned with subjects having substantial public interest.
- **TECHNICAL TRANSLATION.** English-language translations of foreign scientific and technical material pertinent to NASA's mission.

Specialized services that complement the STI Program Office's diverse offerings include creating custom thesauri, building customized databases, organizing and publishing research results . . . even providing videos.

For more information about the NASA STI Program Office, see the following:

- Access the NASA STI Program Home Page at <http://www.sti.nasa.gov>
- E-mail your question via the Internet to help@sti.nasa.gov
- Fax your question to the NASA Access Help Desk at (301) 621-0134
- Telephone the NASA Access Help Desk at (301) 621-0390
- Write to:
NASA Access Help Desk
NASA Center for AeroSpace Information
7121 Standard
Hanover, MD 21076-1320

NASA/CR-2007-213697

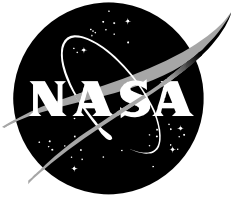

Lessons Learned From Seven Space Shuttle Missions

John Goodman
United Space Alliance
Houston, Texas 77058

Available from:

NASA Center for AeroSpace Information
7121 Standard Drive
Hanover, MD 21076-1320

National Technical Information Service
5285 Port Royal Road
Springfield, VA 22161

This report is also available in electronic form at <http://ston.jsc.nasa.gov/collections/TRS>

Table of Contents

Introduction	7
Rendezvous Target Failure On STS-41B	9
Integrated Rendezvous Target	9
Planned Rendezvous Demonstration	10
Mission Results	11
Cause of the IRT Failure	11
Lessons Learned From STS-41B	11
Rendezvous Trajectory Dispersion On STS-32	13
Planning For LDEF Retrieval	13
STS-32 Rendezvous and LDEF Retrieval	15
Investigation of the Radar Anomaly	16
Lesson Learned From STS-32	17
Rendezvous Lambert Targeting Anomaly On STS-49	19
Deployment Failure Strands the INTELSAT VI (F-3) Satellite	19
The Plan to Rescue INTELSAT With the Space Shuttle	20
New Proximity Operations Tools Flown On STS-49	21
Rendezvous and Capture Attempts On Flight Day 4	22
Rendezvous and Capture Attempts On Flight Day 5	22
New Capture Procedure Development on Flight Day 6	23
Rendezvous and the Targeting Anomaly On Flight Day 7	24
Recovery from the Anomaly and Completion of the Flight Day 7 Rendezvous	25
Successful Capture and Repair of INTELSAT On Flight Day 7	26
Investigation of The Lambert Targeting Anomaly	27
Keys to the Success of STS-49 and Lessons Learned	28
Rendezvous Lambert Targeting Anomaly Before STS-51	29
Investigation of the Targeting Failure and Development of a Procedural Work-Around	30
Correction of the New Targeting Failure	30
Lessons Learned From the STS-51 Pre-Flight Anomaly	30
Zero Doppler Steering Maneuver Anomaly Before STS-59	33
Maneuver Fails to Meet Mission Requirements	33
Investigation of the Maneuver Failure	33
Correction of the Software Anomaly	33
Lesson Learned From The STS-59 Anomaly	34

Table of Contents continued on the next page.

Excessive Propellant Consumption During Rendezvous On STS-69	33
Propellant Consumption During the SPARTAN-201 Rendezvous	35
Post Flight Investigation	35
Lesson Learned From STS-69	36
Global Positioning System Receiver And Associated Shuttle Flight Software Anomalies On STS-91	37
Shuttle Test Flights of the GPS Receiver	37
GPS Receiver and Shuttle Software Anomalies During STS-91	37
Shuttle Avionics System Recovery	39
Investigation of the GPS Receiver and Shuttle Software Anomalies	39
Project Changes Resulting From the Investigation	40
Subsequent GPS Test Flights	42
Ionospheric Scintillation	42
TACAN Replacement By GPS	42
Lessons Learned From STS-91 and the Shuttle GPS Project	42
Overall Lessons Learned	45
Conclusion	47
References	49

Introduction

Incidents resulting in loss of life or loss of spacecraft drive thorough investigation by independent boards and publication of accident reports. Much can be learned from well-written descriptions of the technical and organizational factors that lead to an accident (*Challenger, Columbia*).^{1,2} Subsequent analysis by third parties of investigation reports and associated evidence collected during the investigations can lead to additional insight.³⁻⁷ Much can also be learned from documented close calls that do not result in loss of life or a spacecraft, such as the Mars Exploration Rover Spirit software anomaly, the SOHO mission interruption, and the NEAR burn anomaly.⁸⁻¹⁰

Seven space shuttle incidents discussed in this paper fall into the latter category:

- Rendezvous Target Failure On STS-41B
- Rendezvous Radar Anomaly and Trajectory Dispersion On STS-32
- Rendezvous Lambert Targeting Anomaly on STS-49
- Rendezvous Lambert Targeting Anomaly Before STS-51
- Zero Doppler Steering Maneuver Anomaly Before STS-59
- Excessive Propellant Consumption During Rendezvous On STS-69
- Global Positioning System Receiver and Associated Shuttle Flight Software Anomalies on STS-91

None were a threat to safety of flight. Procedural work-arounds or software changes prevented them from threatening mission success. Extensive investigations, which included the independent recreation of the anomalies by multiple Shuttle Program organizations, were the key to determining the cause, accurately assessing risk, and identifying software and software process improvements. Lessons learned from these incidents not only validated long-standing operational best practices, but serve to promote discussion and mentoring among Shuttle Program personnel and are applicable to future space flight programs.



STS-41B



STS-32



STS-49



STS-51



STS-59



STS-69



STS-91

Table 1 Space Shuttle Missions Discussed In This Report

Shuttle Mission	Orbiter	Launch	Landing	Orbital Inclination	Crew	Mission Objectives
41B	<i>Challenger</i>	2/3/84 Pad 39A	2/11/84 First KSC Landing	28.5°	CDR Vance D. Brand PLT Robert L. Gibson MS Bruce McCandless II MS Ronald E. McNair MS Robert L. Stewart	<ul style="list-style-type: none"> • Deploy WESTAR-VI & PALAPA-B2 • First test of Manned Maneuvering Unit • First Rendezvous Demonstration
32	<i>Columbia</i>	1/9/90 Pad 39A	1/20/90 Edwards	28.5°	CDR Daniel C. Brandenstein PLT James D. Wetherbee MS Bonnie J. Dunbar MS G. David Low MS Marsha S. Ivins	<ul style="list-style-type: none"> • Deploy SYNCOM IV-F5 • Retrieve LDEF
49	<i>Endeavour</i> (First Flight)	5/7/92 Pad 39B	5/16/92 Edwards	28.35°	CDR Daniel C. Brandenstein PLT Kevin P. Chilton MS Pierre J. Thuot MS Kathryn C. Thornton MS Richard J. Hieb MS Thomas D. Akers MS Bruce E. Melnick	<ul style="list-style-type: none"> • Intelsat VI Repair
51	<i>Discovery</i>	9/12/93 Pad 39B	9/22/93 KSC	28.45°	CDR Frank L. Culbertson PLT William F. Readdy MS James H. Newman MS Daniel W. Bursch MS Carl E. Walz	<ul style="list-style-type: none"> • Deploy ACTS/TOS • Deploy/Retrieve ORFEUS-SPAS
59	<i>Endeavour</i>	4/9/94 Pad 39A	4/20/94 Edwards	57°	CDR Sidney M. Gutierrez PLT Kevin P. Chilton PLC Linda M. Godwin MS Jay Apt MS Michael R. Clifford MS Thomas D. Jones	<ul style="list-style-type: none"> • Space Radar Lab (SRL-1)
69	<i>Endeavour</i>	9/7/95 Pad 39A	9/18/95 KSC	28.4°	CDR David M. Walker PLT Kenneth D. Cockrell PLC James S. Voss MS James H. Newman MS Michael L. Gernhardt	<ul style="list-style-type: none"> • Deploy & Retrieve SPARTAN 201-03 & Wake Shield Facility 2
91	<i>Discovery</i>	6/2/98 Pad 39A	6/12/98 KSC	51.6°	CDR Charles J. Precourt, PLT Dominic L. Pudwill Gorie MS Wendy B. Lawrence MS Franklin R. Chang-Diaz MS Janet L. Kavandi MS Valery V. Ryumin	<ul style="list-style-type: none"> • 9th & Final Mission to Mir

CDR – Commander, KSC – Kennedy Space Center, MS – Mission Specialist, PLC – Payload Commander, PLT – Pilot

Rendezvous Target Failure On STS-41B

The goal of the mission of *Challenger* on STS-41B (February 1984) was to perform the first demonstration of the space shuttle's integrated rendezvous navigation and maneuver targeting capability.¹¹ This demonstration was important to reduce risk to the Solar Maximum Mission rendezvous and satellite repair scheduled for the following April on STS-41C. The Integrated Rendezvous Target (IRT) would serve as the target spacecraft (Figure 1). After the rendezvous, ground radars would track the IRT for an atmospheric drag study.

Other mission objectives included deployment of the WESTAR-VI and PALAPA-B2 communications satellites with their Payload Assist Module-D (PAM-D) propulsion units, and the first demonstration of Manned Maneuvering Unit (MMU). The MMU permitted untethered Extra-Vehicular Activities (EVA) and would be used as the primary means to capture Solar Max on STS-41C.

Integrated Rendezvous Target

The IRT was a 200 lb. satellite to be deployed from the forward shuttle payload bay Get-Away Special canister beam. It consisted of a 6 meter diameter, one-mil thick aluminized Mylar balloon, an inflation system, and ballast (Figure 2). The balloon, to be inflated after deployment, was white in color, except for one panel painted infrared black (Figures 3 and 4). The IRT provided known radar signal reflection and atmospheric drag characteristics for the rendezvous demonstration and orbital decay study.



Figure 1 IRT project patch showing stave separation and balloon inflation.

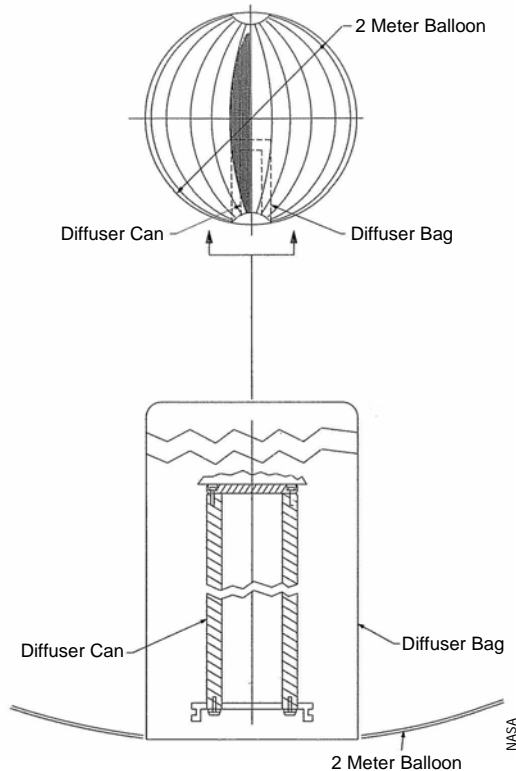

Figure 2 Engineering drawing of the IRT balloon and inflation system.



Figure 3 Test inflation of the back-up IRT balloon in a thermal vacuum test chamber.



Figure 4 Deflated IRT balloon.

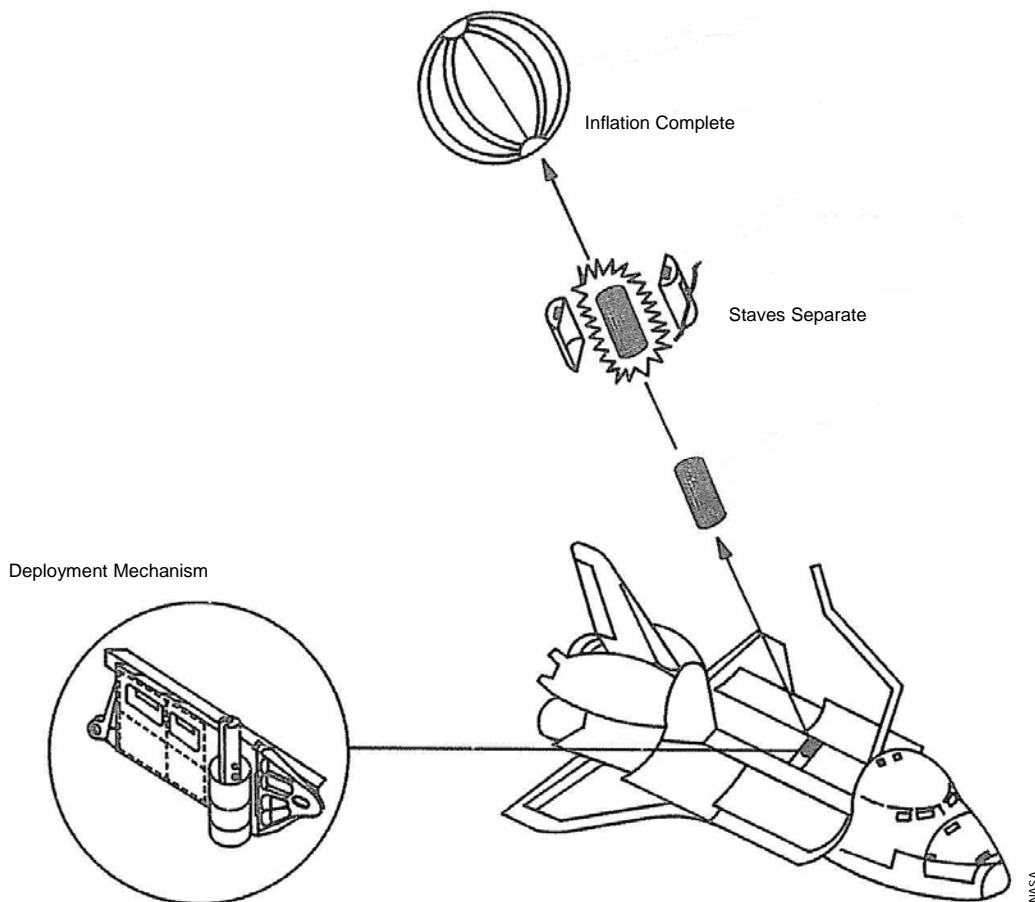

Figure 5 IRT deployment sequence.

Planned Rendezvous Demonstration

The IRT was to be deployed from *Challenger* at 1.5 feet/second in a retrograde direction by a spring mechanism (Figure 5). At deployment three lanyards were to be pulled to activate two delayed pyrotechnic charges and to close a balloon bleed valve. Approximately one minute after deployment, at a range of approximately 75 feet, the first delayed pyrotechnic charge was to fire and separate the staves from the un-inflated balloon and inflation hardware. The second delayed pyrotechnic charge was to fire at approximately 80 seconds after deployment to initiate inflation of the balloon with gaseous nitrogen.

During deployment the IRT was to be tracked using laser rangefinders that were a part of the payload bay Closed Circuit Tele-Vision (CCTV) system to evaluate the usefulness of the CCTV lasers as a source of range and range rate data during proximity operations. Soon after deployment rendezvous radar acquisition of the IRT was to occur and the radar data would be processed by the shuttle's rendezvous navigation software. A separation burn was to take *Challenger* to a position approximately 8 nautical miles behind the IRT. During a period of 3.5 hours after deployment rendezvous radar, star tracker, and Crew Optical Alignment Sight (COAS) data was to be processed by the shuttle rendezvous navigation system, and several maneuvers were to be targeted using the on-board software.

One or two days of relative navigation, maneuver targeting, and maneuver execution activities could be conducted based on other mission planning constraints. *Challenger* could rendezvous with the IRT on the same day as the deploy, or phase out overnight to a range of approximately 140 nautical miles and rendezvous the next day. In either case, *Challenger* was to use a rendezvous profile similar to that planned for the STS-41C Solar Max rendezvous and repair to further exercise the on-board rendezvous navigation and maneuver targeting capabilities.

Mission Results

The WESTAR-VI satellite was deployed but failed to achieve the desired geosynchronous orbit due to a failure of the PAM-D unit. Deployment of the PALAPA-B was delayed for two days as it used the same PAM-D stage. However, the PALAPA-B PAM-D stage malfunctioned as it did after the WESTAR-VI deploy. Both satellites were later recovered on STS-51A (November 1984).¹¹

The IRT was deployed on February 5th. The crew reported that the IRT staves did not separate after deployment, and that the balloon inflated inside the staves and burst. Due to the potential for re-contact with IRT debris the crew performed a breakout maneuver. The rendezvous demonstration was canceled.

Some rendezvous navigation sensor data was collected. The rendezvous radar maintained track of the IRT debris to a range well over 100,000 feet. Three data collection periods for COAS data and four for star tracker data were performed. The last star tracker data was obtained at a range of ~60 nautical miles. The crew was able to visually track the IRT debris at ~62 nautical miles. The IRT re-entered the atmosphere on February 11. No CCTV laser data was collected after the IRT deployment, but some data was collected during MMU flight testing in close proximity to *Challenger*. Laser range rate data was too noisy to be used as a piloting aid.

Rendezvous navigation and maneuver targeting performance on the next mission, STS-41C (April 1984) was successful. Two rendezvous profiles were successfully executed before Solar Max was captured and placed in the payload bay of *Challenger* for repair.

Cause of the IRT Failure

A post-flight investigation revealed that a lanyard connection failed open which prevented activation of a delayed action pyrotechnic charge that would have triggered the stave cable cutter sequence. An improper crimping tool was used when the lanyard assembly was manufactured. A different type of lanyard connection that was less susceptible to failure should have been used.

Lessons Learned From STS-41B

- **Quality control during manufacture should be rigorous enough to ensure that proper tools, procedures, and materials are used.** Malfunctions can result in degraded system performance or system failure that could negatively impact mission success or safety of flight.
- **Choose component designs and system architectures that lower the risk of failure and enable the system to function within requirements in the presence of failures.** Some proposed component designs and system architectures may be more robust than others.

This page intentionally left blank.

Rendezvous Radar Anomaly and Trajectory Dispersion On STS-32

The original concept for The Long Duration Exposure Facility (LDEF, Figure 6) was proposed as the first shuttle payload, called the Meteoroid and Exposure Module (MEM). MEM was renamed LDEF in 1974. The mission of LDEF was to provide data on long-term exposure effects of the space environment on various materials. The requirement to retrieve the gravity gradient stabilized LDEF with the shuttle (along with Solar Max) drove extensive development of shuttle proximity operations procedures due to plume impingement concerns in the mid and late 1970s.¹¹ LDEF was designed and constructed at NASA Langley between January 1976 and August 1978. LDEF was deployed from the Shuttle *Challenger* during mission STS-41C on April 7, 1984, at an altitude of approximately 275 nautical miles.

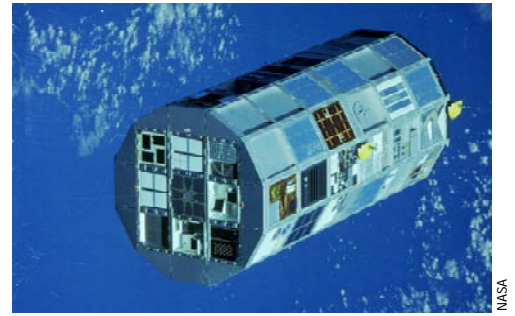

Figure 6 LDEF after deployment from *Challenger*.

Planning For LDEF Retrieval

LDEF was supposed to have been retrieved in March of 1985 on STS-51D, then in September of 1986 by STS-61I. However, this mission was canceled due to the loss of the Shuttle *Challenger*. Once shuttle missions resumed *Columbia* was scheduled to retrieve LDEF on STS-32. Higher priority missions prevented the LDEF from being retrieved sooner after the September 1988 return to flight. Accelerated LDEF orbital decay due to the solar maximum (Figures 7 and 8), *Columbia* launch delays, and the SYNCOM IV-5 deploy two days before the LDEF rendezvous complicated mission planning. Orbital lifetime prediction of LDEF had a high degree of uncertainty, and experience with Skylab in 1978 and 1979 heightened concerns that LDEF could reenter the atmosphere before retrieval (Figures 9 and 10). It was desired to retrieve LDEF before it decayed to 160 nautical miles, as the aerodynamic torque could exceed the gravity gradient torque and cause the satellite to tumble.



Figure 7 A button worn by many Shuttle Program personnel before and during the flight of STS-32.

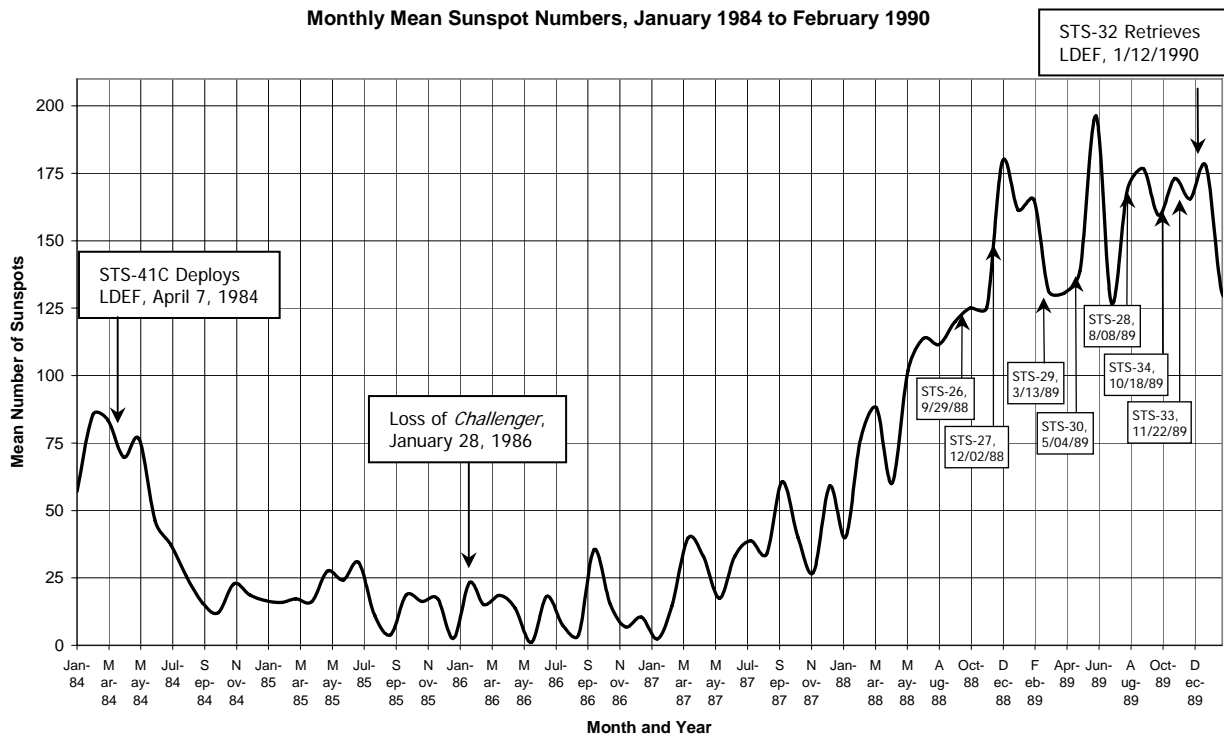
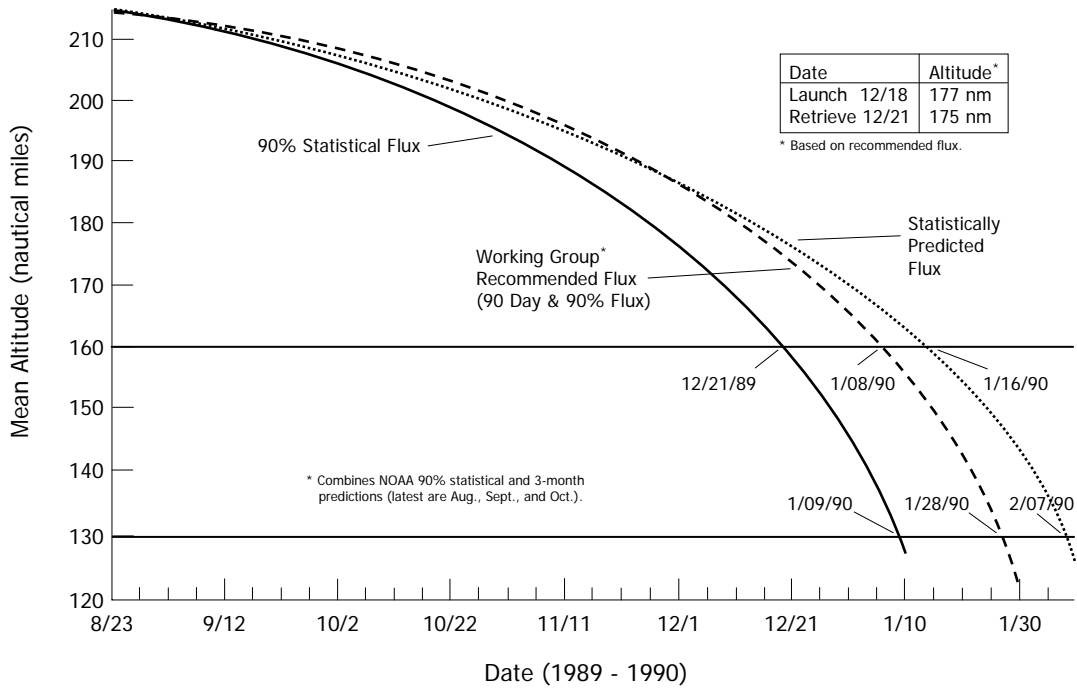

Figure 8 Plot of monthly mean sunspot numbers from January 1984 to February 1990. Date Source - ftp://ftp.ngdc.noaa.gov/STP/SOLAR_DATA/SUNSPOT_NUMBERS/, accessed March 14, 2006.



Based on current predictions LDEF will most likely arrive at 160 nm between 12/21/89 and 1/16/90. However, uncertainties will change these dates over the next 4 months.

Figure 9 September 1989 predicted orbital decay of LDEF. Plot courtesy of NASA/Cheryl Andrews.

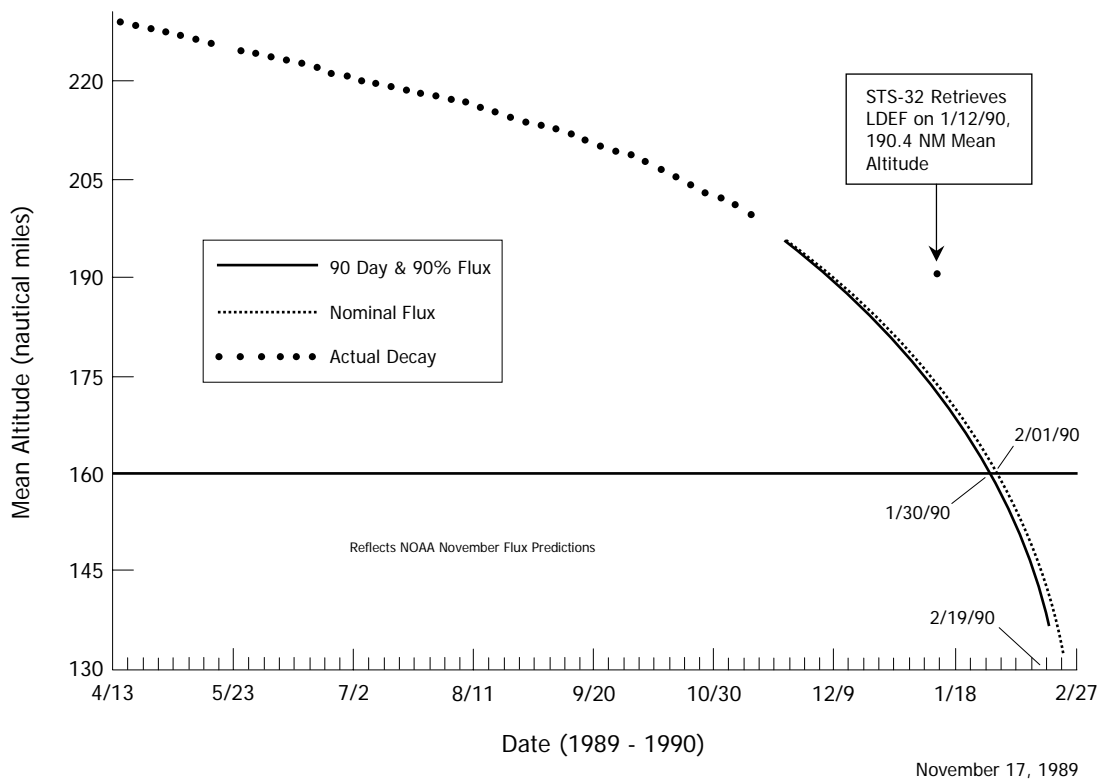
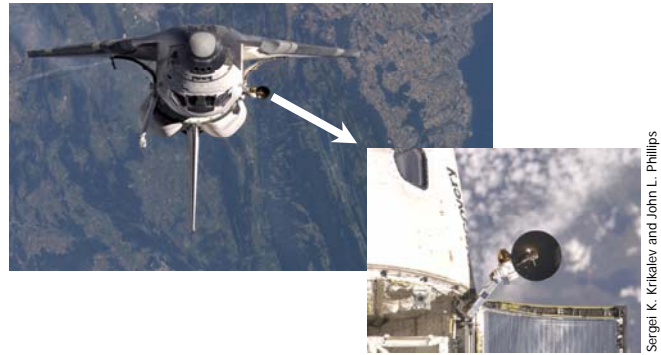

Figure 10 Actual and predicted orbital decay of LDEF. Plot courtesy of NASA/Cheryl Andrews.

STS-32 Rendezvous and LDEF Retrieval

Columbia was finally launched on January 9, 1990. Due to the size of large LDEF the crew was able to visually acquire it the day before the rendezvous at a range of about 100 nautical miles. Radar lock (Figure 11) on the LDEF began per published crew procedures at a range of 148,500 ft, just before the second star tracker pass (Figure 12, Item 2). Rendezvous procedures had been written based on the pre-flight planned trajectory. This trajectory showed that radar would not be acquired until after the NCC burn, and that radar data would not be incorporated until after the NCC maneuver was complete (Figure 12). Even though the radar locked on early, the data looked good, and Mission Control requested that the radar data be incorporated into navigation.



Sergei K. Krikalev and John L. Phillips

Figure 11 Location of the shuttle rendezvous radar. The photos were taken during the STS-114 R Bar Pitch Maneuver (RPM) as *Discovery* approached the International Space Station on July 28, 2005.

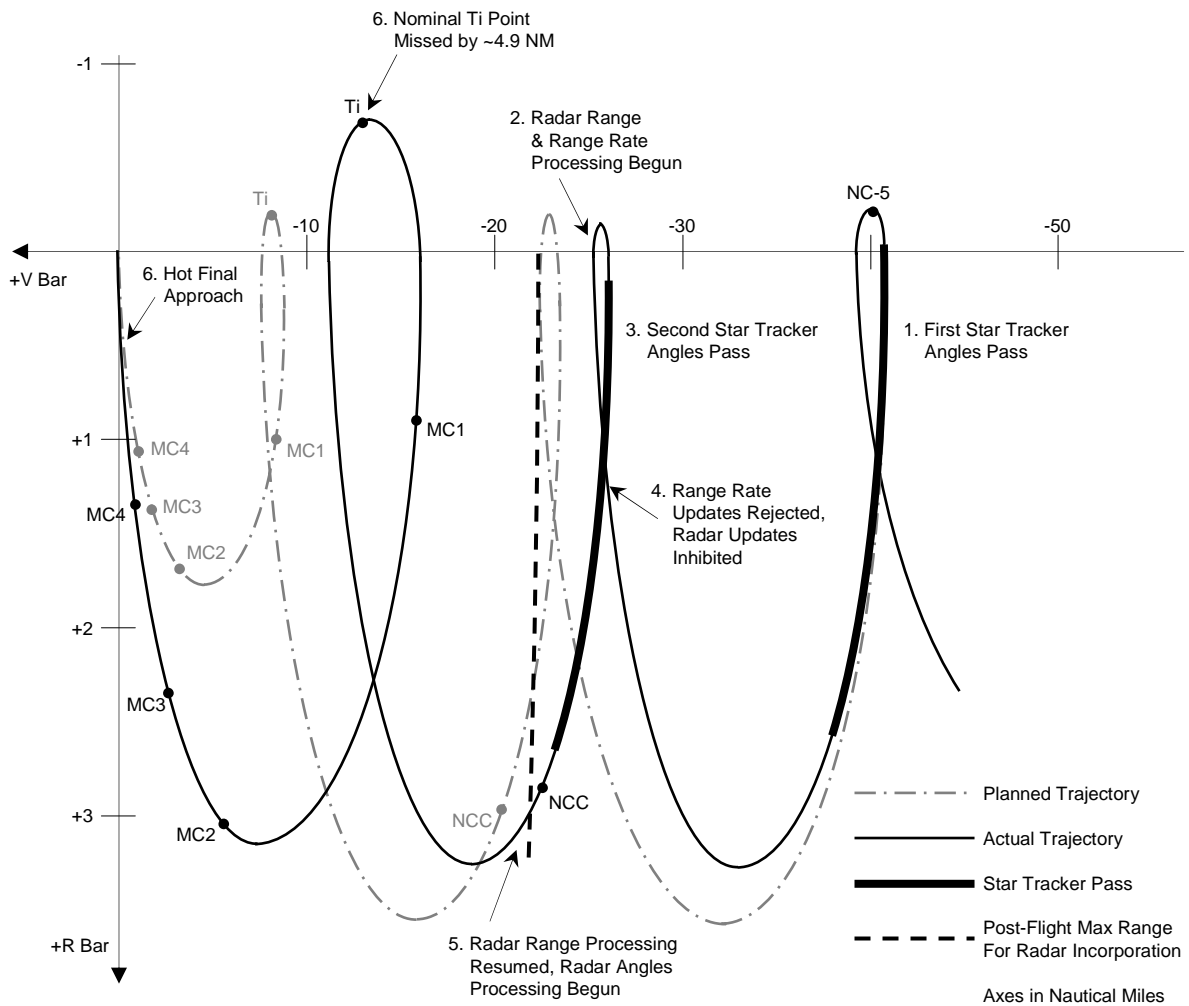

Figure 12 Relative motion plot illustrating the planned and actual trajectories during the STS-32 rendezvous with LDEF.

During the star tracker pass star tracker angle measurements and radar range and radar range rate measurements were processed. The quality of the radar range and range rate data began to degrade during the pass, and the onboard navigation filter rejected two range rate measurements (Figure 13 and Figure 12, item 4). The radar measurements were noisier than expected, and the quality of the onboard navigation state was degraded. Radar range and range rate data was inhibited at Mission Control request, while star tracker data processing continued. The star tracker pass was completed without incident.

	A	D	S	RESID	RATIO	MARK-ACPT	HIST-REJ
ARMS	A	*	P	1.049	0.38	218	0
ARRT	A	*	X	52.07	7.00	215	2
S EL	A	*	P	-0.00	0.01	302	0
S AZ	A	*	P	-0.01	0.02	302	0

Figure 13 Portion of a screen print of a Mission Control display showing two rejected radar range rate measurements during the star tracker pass.

The onboard solution for the NCC maneuver (Figure 12) was 4 feet/second higher than expected, but was burned. After the NCC burn, radar range, range rate, and angles were processed (Figure 12, Item 5). However, several range rate spikes led to Mission Control to ask the crew to inhibit range rate processing. Radar range and angles continued to be processed for the rest of the rendezvous. Onboard rendezvous navigation filter performance during the rest of the rendezvous was as expected. The larger NCC burn resulted in a miss of the desired point of the next burn, Transition Initiation (Ti) by about 4.9 nautical miles (Figure 12, Item 6).

The final closing trajectory on LDEF was at a higher relative velocity than expected, but the crew performed additional braking and began the proximity operations phase. *Columbia* arrived on the -R Bar (above LDEF) within one minute of the pre-flight predicted time (Figure 14). The gravity gradient stabilized LDEF was in the expected attitude. The LDEF grapple (Figure 15) with the Remote Manipulator System (RMS) and berthing in the payload bay was successfully accomplished without incident, with only a few weeks of LDEF orbital lifetime left (Figure 10).

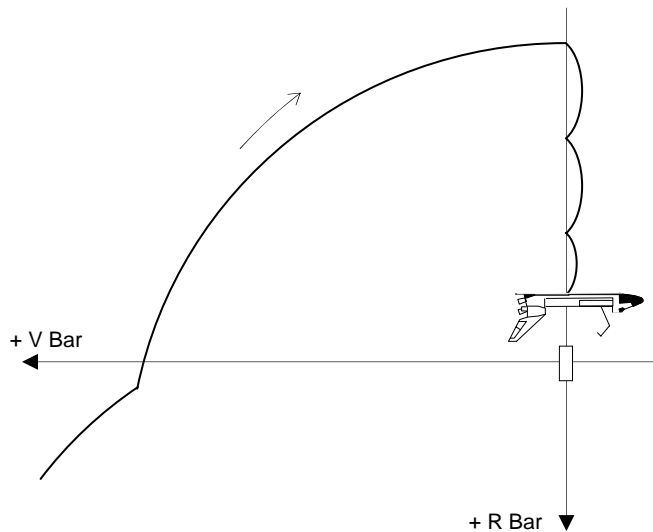

Figure 14 *Columbia* Approach to LDEF



Figure 15 LDEF after grappling by the RMS of *Columbia* on STS-32 on January 12, 1990.

Investigation of the Radar Anomaly

Post-flight analysis indicated that the star tracker data alone would have provided accurate data for a satisfactory NCC burn solution. It was discovered that at extreme range (but still shorter than the maximum tracking range based on signal strength) a variable range measurement bias was introduced by the radar hardware. The bias, which increases with increasing range, corrupts both range and range rate measurements while the signal strength remained acceptable. This maximum effective range of the radar was a design limitation concerning transmission pulse timing rather than a performance limitation on signal strength. This maximum effective range defined by the introduction of the bias fell between the certified maximum range and the maximum tracking range (Figure 16). While radar data was good when lock-on was achieved (Figure 12, Item 2), the maximum effective range was exceeded during the second star tracker pass (Figure 12, item 3), which led to the biased

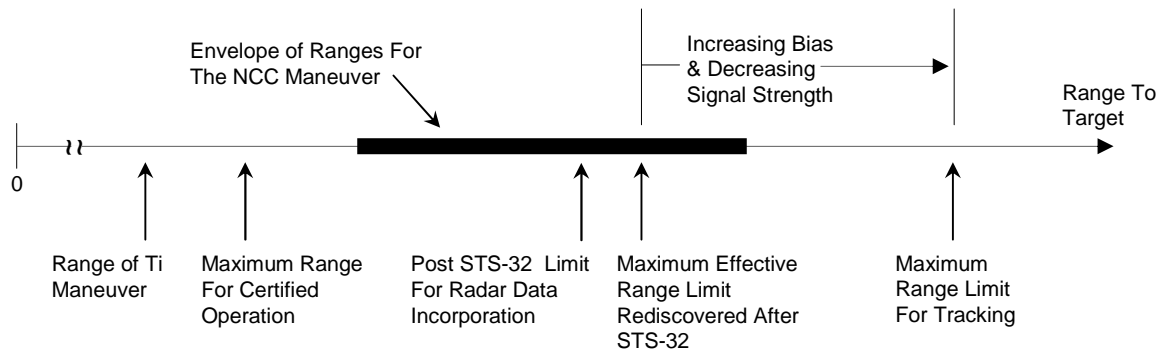

Figure 16 Certified, effective, and maximum tracking ranges of the rendezvous radar. Range at the NCC maneuver is trajectory dependent.

range and range rate measurements, and the rejection of two range rate measurements by the navigation filter (Figure 12, Item 4, and Figure 13).

The bias phenomenon and the range over which it can occur is a characteristic of the radar’s design and was known to shuttle personnel very early in the program (late 1970s & early 1980s), but the knowledge had not been preserved and incorporated into procedures documents. At the time of STS-32 Shuttle Program personnel were only aware of the certified maximum tracking range and the longer maximum tracking range limit of the radar. Knowledge of the design limitation surfaced only after investigation team members contacted one of the original radar design engineers who had retired several years before.

In addition, signal strength at the long ranges during STS-32 was found to be lower (but still acceptable) and signals noisier than at closer ranges (after NCC) at which radar data was normally processed. STS-51I was the only other mission during which radar data was acquired before the effective range limit. However, the range from *Discovery* to the SYNCOM decreased to below the maximum effective radar range before data was incorporated into navigation, thus avoiding the radar measurement bias (Table 2).

Table 2 Radar Acquisition and Processing History

Shuttle Mission	Date	Orbiter	Target	Radar Data Acquired Before Effective Limit	Radar Data Processed Before Effective Limit
41C	April 1984	<i>Challenger</i>	Solar Max	No	No
51A	November 1984	<i>Discovery</i>	Palapa-B2	No	No
51A	November 1984	<i>Discovery</i>	Westar-VI	No	No
51D	April 1985	<i>Discovery</i>	SYNCOM IV-3	No	No
51G	June 1985	<i>Discovery</i>	SPARTAN-101	No	No
51I	Aug./Sept. 1985	<i>Discovery</i>	SYNCOM IV-3	Yes	No
32	January 1990	<i>Columbia</i>	LDEF	Yes	Yes

After STS-32, procedures and training were modified so that radar data would only be processed at ranges where the bias could not occur (Figure 16 and the dashed line in Figure 12). An investigation was conducted to determine if any additional information about the rendezvous radar had been lost that could result in performance problems.

Lesson Learned From STS-32

- **Fully document the design and performance characteristics of sensors both inside and outside of the certified performance envelope.** Sensors may be capable of both nominal and off-nominal performance outside of the certified performance envelope. Any design or performance limitations in this region should be documented and incorporated into procedures or software to prevent use of anomalous data, or enable use of the sensor outside the certified envelope when needed.

This page intentionally left blank

Rendezvous Lambert Targeting Anomaly On STS-49

The mission of STS-49 was to rendezvous with, capture, and attach a new Perigee Kick Motor to the stranded INTELSAT VI (F-3) communications satellite.¹¹ The satellite would then be deployed so it could resume its mission and reach an operational geosynchronous orbit. While the mission was successful, three rendezvous profiles and three Extra-Vehicular Activities (EVAs) were performed before INTELSAT was finally captured and berthed in the payload bay of *Endeavour*, due to problems with the original satellite capture technique. During the third rendezvous, a Lambert targeting failure forced the crew and Mission Control to execute alternate procedures that had been practiced for years in simulations, but had never before been done in flight. STS-49 was one of the most challenging space shuttle missions ever flown. Firsts for this mission include:

- A record three rendezvous profiles were successfully flown.
- The longest space walk in U.S. history up to that time.
- Four space walks performed in one mission.
- The first and so far only time three astronauts performed an EVA at once.
- Attachment of a new rocket motor to a satellite.
- Development of a new satellite capture technique during a mission.
- First execution of a rendezvous delay maneuver.
- First use of a proximity operations situational awareness program with data from laser sensors.

The cause of the Lambert targeting failure was corrected after the mission. However, a software feature added after STS-49 to improve Lambert targeting performance caused another targeting failure five days before the launch of STS-51. This anomaly was later corrected as well.

Deployment Failure Strands the INTELSAT VI (F-3) Satellite

On March, 14, 1990, the INTELSAT VI (F-3) communications satellite (Figure 17) was launched by a commercial Titan-3. The Titan second stage failed to separate from the satellite and its Perigee Kick Motor (PKM). This prevented the satellite from continuing its mission and reaching the intended orbit. An omni antenna was deployed to receive ground commands (Figure 18), but all other antennas remained stowed. Satellite controllers on the ground commanded the INTELSAT to separate from the PKM, leaving the PKM attached to the Titan-3 second stage.

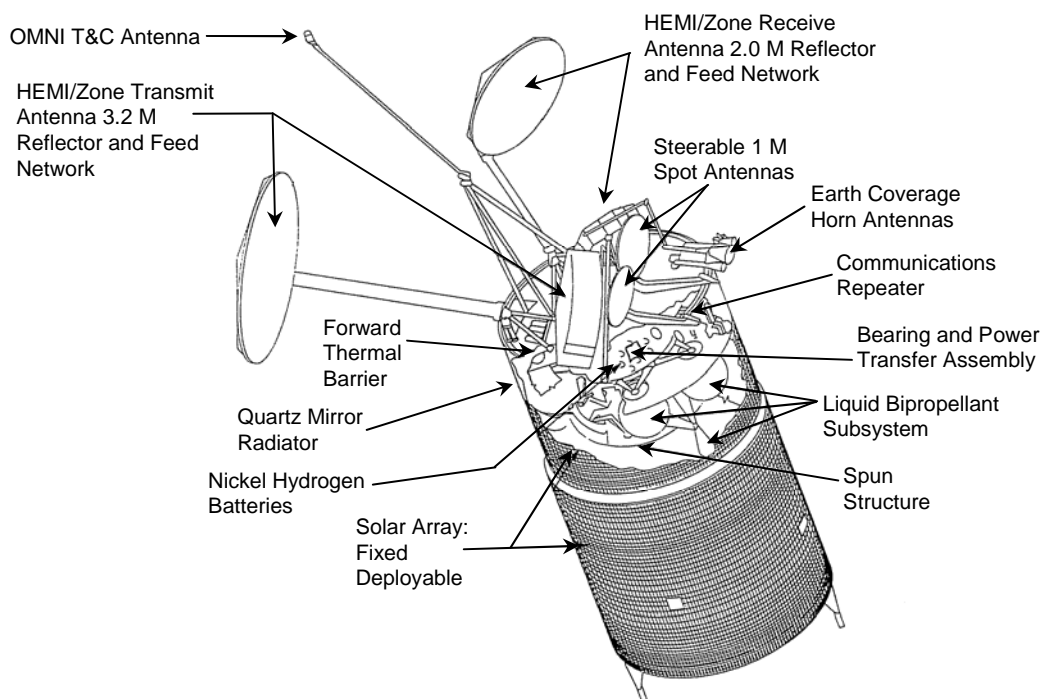

Figure 17 Operational configuration of an INTELSAT VI communications satellite.

Ground commands spin-stabilized the spacecraft, at 25 Revolutions Per Minute (RPM), and it was placed in a stable power and thermal configuration. Maneuvers were performed to place the satellite in a high enough orbit to prevent reentry and to minimize atomic oxygen impacts to the solar cells. The maneuvers were conducted with the two liquid apogee motors. The INTELSAT orbit was adjusted over several days from an approximately 93 by 193 nautical mile orbit to an approximately 299 by 309 nautical mile orbit.

The Plan to Rescue INTELSAT With the Space Shuttle

In an attempt to salvage the satellite, a rescue and repair plan involving the space shuttle was developed, so a new PKM could be attached to the INTELSAT and enable it to reach an operational orbit.^{12,13} Capture of INTELSAT was to be performed by an EVA astronaut using a capture bar (Figures 19 and 20) while positioned on a Portable Foot Restraint mounted on the Remote Manipulator System (RMS, shuttle robotic arm).

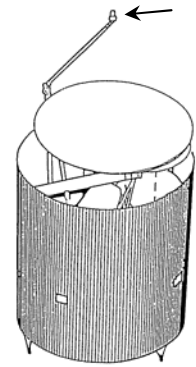

Figure 18
On-orbit configuration with deployed OMNI antenna.

A crew member inside the orbiter would maneuver the EVA crewman into the INTELSAT capture position. A second EVA crew member was in the shuttle payload bay. Once the INTELSAT was captured (a soft dock), any rotation and nutation would be halted using a steering wheel on the capture bar. After the EVA crew hard docked the capture bar to the INTELSAT, the RMS would grapple the capture bar (see Figure 20) and position the satellite in the payload bay so the EVA crew could berth it. The new PKM would then be attached to the INTELSAT by the EVA crew.

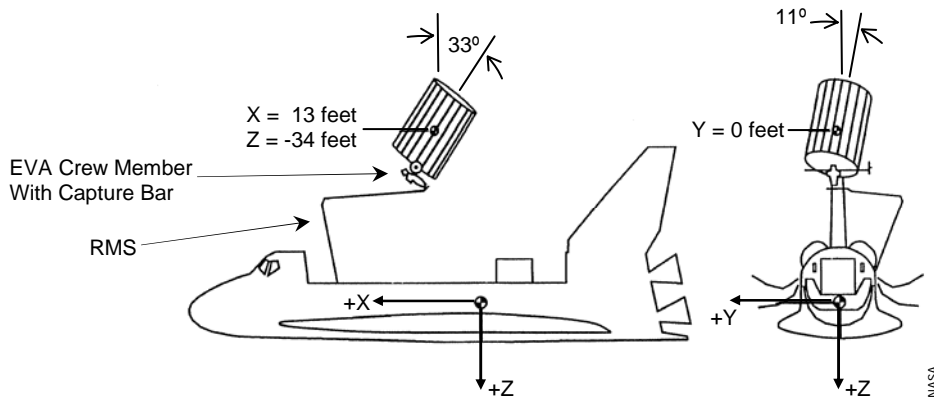

Figure 19 Position of INTELSAT for capture bar technique.

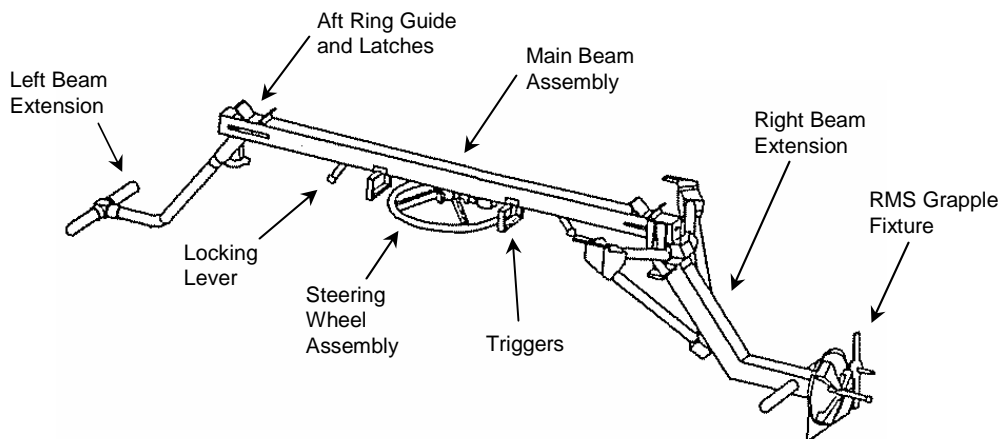

Figure 20 Capture bar used in capture attempts on flight days 4 and 5.

New Proximity Operations Tools Flown On STS-49

The use of a new proximity operations situational awareness program and new laser sensors were to play an important role in the success of STS-49. During shuttle systems development in the 1970s three proximity operations sensors were identified and developed.¹¹ These included rendezvous radar (range, range rate, and angles), range data derived from Crew Optical Alignment Sight (COAS) subtended angles, and Closed Circuit Television (CCTV) camera ranging rulers. While these data sources were flight proven, they were not optimal for proximity operations in terms of the operating envelope and procedural complexity. An early generation laser sensor had been flown on STS-41B (February 1984) and STS-41C (April 1984), but the range rate data was too noisy to use for piloting. This laser was a part of an auto focusing system for the CCTV cameras in the orbiter payload bay.

Two later generation laser sensors (short and long range) were first flown on STS-49 for comparison with data from the rendezvous radar. If laser performance was acceptable for piloting cues, the crew could obtain range and range rate through the aft flight deck windows as a supplement to radar data. However, STS-49 proximity operations were designed so that mission objectives could be met without the laser data.

The Payload Bay program (Figure 21), hosted on a laptop computer, enhanced crew situational awareness of relative motion during proximity operations. Payload Bay was written by Richard J. Hieb, a former Mission Control rendezvous officer who became an astronaut and was on the STS-39 and STS-49 crews (Figure 22). Payload Bay was tested by the STS-39 crew during simulations in the Systems Engineering Simulator (SES). Improvements identified in the SES were incorporated into the program in time to support its first flight on STS-49. Data from both the short and long range lasers could be provided to the Payload Bay program, along with radar data and CCTV camera angles. Later it evolved into the Rendezvous and Proximity Operations Program (RPOP). RPOP along with the Hand-Held Laser and Trajectory Control Sensor laser (mounted in the payload bay) were to see extensive use during missions to Mir and the International Space Station.¹⁴



Figure 22 Rick Hieb in the airlock before an STS-49 EVA.

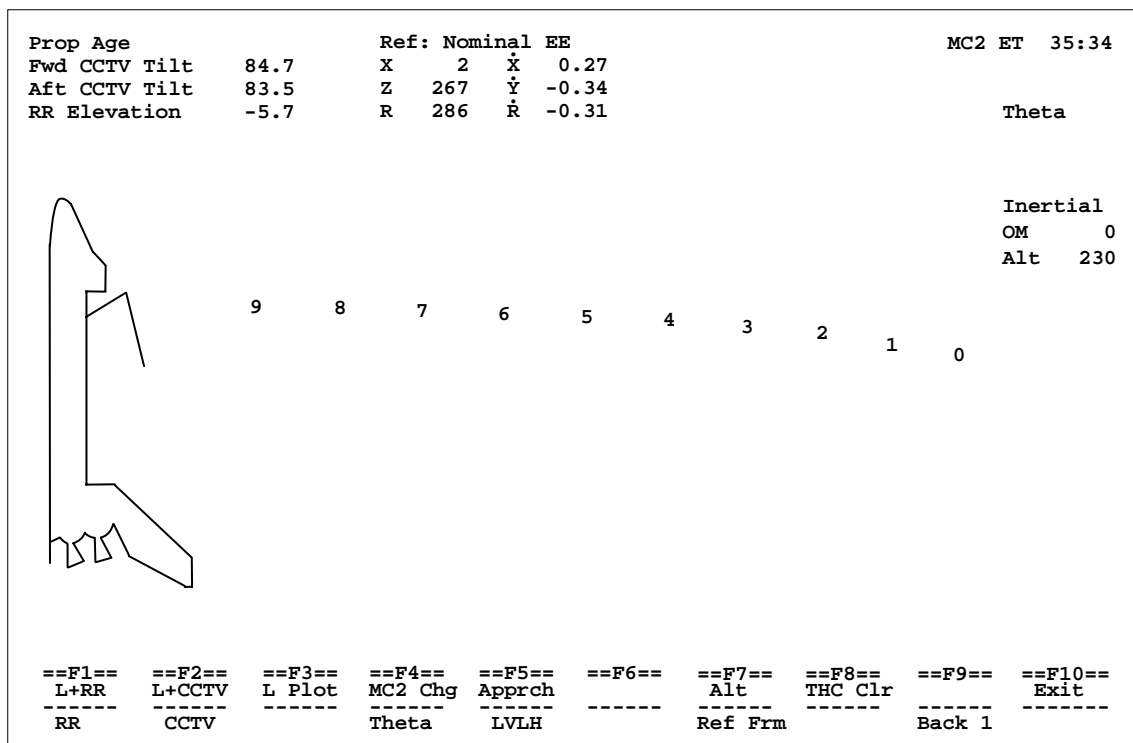

Figure 21 Example of a payload bay display, Circa 1992.

Rendezvous and Capture Attempts On Flight Day 4

The launch of *Endeavour* occurred on May 7, 1992, with the capture of the INTELSAT planned for Flight Day 4.* The INTELSAT then maneuvered so that it would be placed in a “control box” five hours after liftoff of the *Endeavour*.¹³ INTELSAT ground controllers reduced the satellite’s rotation rate to a value that would facilitate capture. Two hours before rendezvous, ground commanding of the INTELSAT was stopped. The rendezvous and proximity operations phases were successfully executed by *Endeavour*. Two initial attempts to capture the INTELSAT during orbital night (with the *Endeavour* payload bay lights providing illumination) failed (Figures 23 and 24). The capture failures modified the INTELSAT rotational dynamics such that a third attempt could not be safely conducted. The crew performed a small maneuver to back *Endeavour* away from the INTELSAT, and later performed a break-out maneuver designed to safely separate the two spacecraft and maintain safe separation overnight so that Mission Control could reassess the situation. The laser sensors and Payload Bay program improved crew situational awareness, prompting them to rely more on these tools during proximity operations on subsequent days.

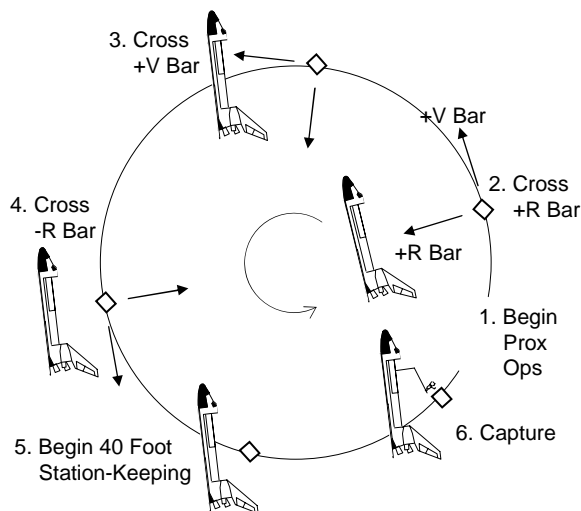

Figure 23 Planned proximity operations for flight day 4.

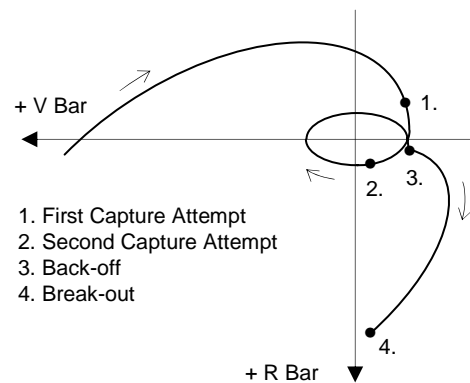

Figure 24 Sketch of actual proximity operations on flight day 4.

Rendezvous and Capture Attempts On Flight Day 5

Two more maneuvers were performed to position the orbiter for another rendezvous on the next day, Flight Day 5. The second rendezvous was planned so enough propellant would be available for a third rendezvous later in the mission, if required. Procedural changes were made to the proximity operations phase to improve the chances of capture. All capture attempts were to be performed in orbital daylight (as the INTELSAT was dark in color), based on the Flight Day 4 experience. Navigation, maneuver targeting, and piloting activities during the Flight Day 5 rendezvous were successful. The mission commander performed several fly-arounds of the INTELSAT to achieve optimal relative geometry for capture attempts (Figures 25 and 26). However, multiple attempts to capture the INTELSAT during orbital daylight again failed (Figure 27). After the final attempt the INTELSAT was in a flat spin and the crew executed a break-out maneuver to safely separate the two vehicles.



Figure 25 INTELSAT above the Kennedy Space Center before a capture attempt.

* The day of launch is Flight Day 1, and each subsequent Flight Day begins when the crew awakens from a sleep period.

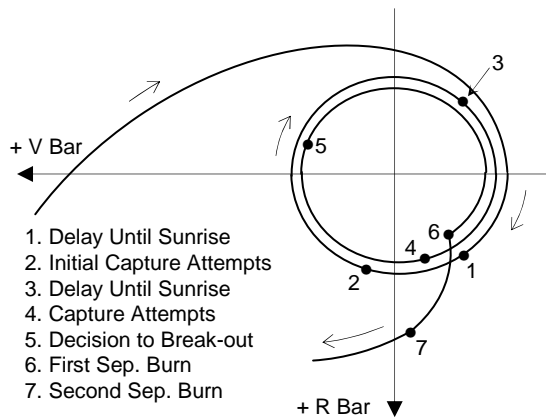

Figure 26 Sketch of proximity operations after the second rendezvous on flight day 5.

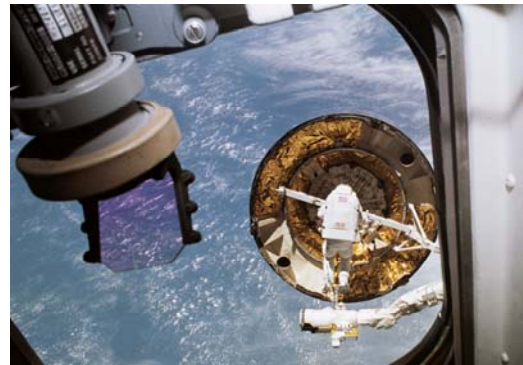

Figure 27 EVA crewman on the RMS attempts to capture INTELSAT with the capture bar (right).

New Capture Procedure Development on Flight Day 6

A third rendezvous and capture attempt was planned for Flight Day 7. Since the EVA crew member could not keep the capture bar in contact with the INTELSAT long enough for the capture latches to fire, numerous alternate capture methods were discussed. Most were discarded due to operational difficulties. The crew and ground personnel concurred on using three EVA crew in the payload bay to capture the satellite using their gloved hands, rather than using the now suspect capture bar technique.

On Flight Day 6, with *Endeavour* at a long range behind INTELSAT, Mission Control EVA personnel and astronauts conducted simulations of the proposed three person EVA technique in the Weightless Environment Training Facility (WETF)[†] to evaluate the difficulties of a three person EVA and communications procedure (Figure 28). Astronauts and Mission Control rendezvous personnel conducted proximity operations simulations in the Systems Engineering Simulator to evaluate piloting procedures and visual cues. INTELSAT and shuttle engineering personnel examined the INTELSAT for “grab” areas and safety concerns.

Proximity operations specialists conducted additional analysis of Shuttle Reaction Control System (RCS) jet plume impacts on INTELSAT rotational dynamics. Since EVA crew would be mounted on a truss structure in the payload bay using foot restraints, analysis was performed to ensure that imparted loads during RCS jet firings would not exceed truss structural tolerances. Digital camera photos of crew sketches of proposed techniques were transmitted from *Endeavour* to Mission Control, and the teams on the ground used the photos in technique definition and refinement. By the end of Flight Day 6, a workable plan to use three EVA crew for the capture was in place.

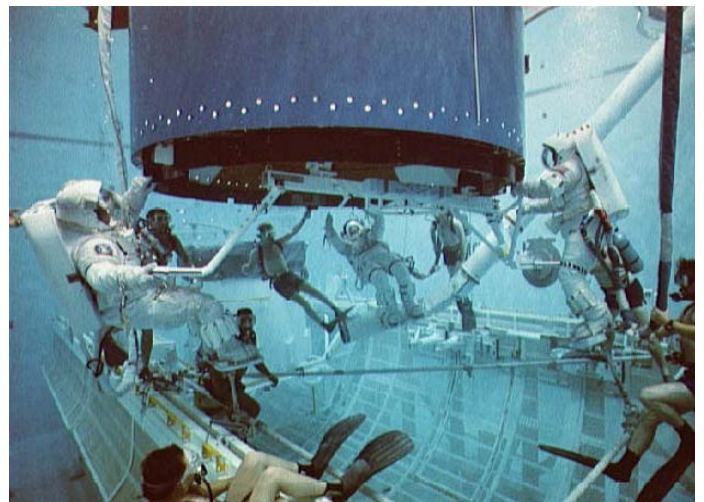

Figure 28 Astronauts developing the alternate capture procedure in the WETF.

[†] The WETF was a large pool in which astronauts and engineering personnel could develop and practice EVA techniques while wearing neutrally buoyant EVA suits. The Neutral Buoyancy Lab (NBL), whose larger size was needed for the International Space Station Program, later replaced the WETF. All underwater EVA simulations are conducted in the presence of professional safety divers.

Rendezvous and the Targeting Anomaly On Flight Day 7

After *Endeavour* began its return to INTELSAT, two star tracker passes and a midcourse correction (NCC) maneuver were successfully performed (Figure 29). However, a targeting attempt soon after NCC for the next maneuver, Transition Initiation (Ti[‡]), failed to converge on a solution (item 1 in Figure 29, Figure 30).

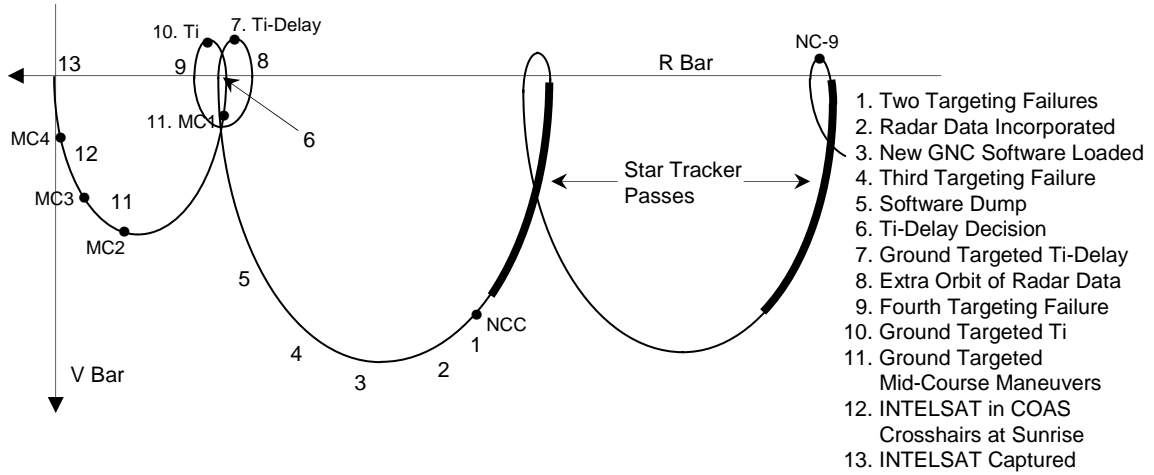

Figure 29 Sequence of events during the third rendezvous of STS-49.

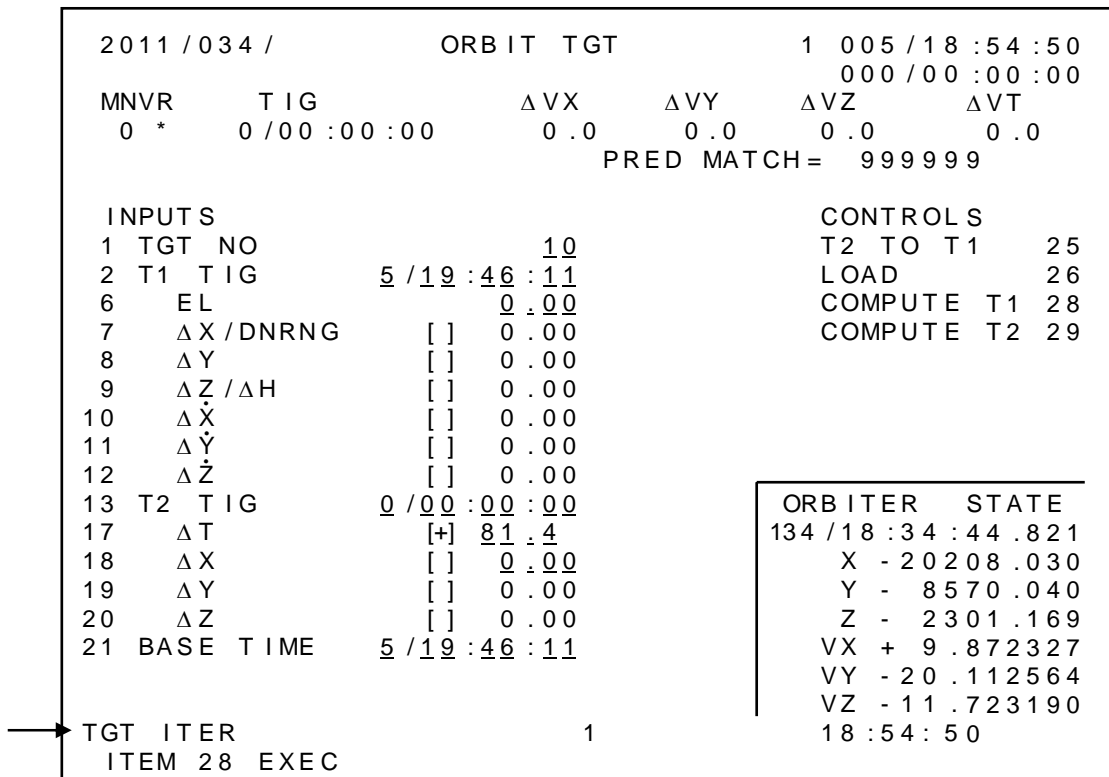

Figure 30 Failed Ti targeting attempt recreated by the author during the investigation using the Software Production Facility.¹⁵ Arrow indicates alarm message seen by the crew on *Endeavour*.

[‡] The Transition Initiation (Ti) maneuver placed *Endeavour* on an intercept trajectory with INTELSAT. The “i” in the acronym “Ti” is lowercase to avoid confusion with another Shuttle Program acronym.

Mission Control rendezvous and shuttle software specialists quickly identified the source of the targeting failure to a specific area of the Lambert targeting code. Radar data was obtained and incorporated into the shuttle navigation solution. In case the Guidance, Navigation, and Control (GNC) software had become corrupted, the crew reloaded new GNC software from the Mass Memory Units into the GNC computers. However, the targeting failure occurred again after the software reload (Figure 31). The GNC software was then transmitted to Mission Control for further offline analysis. The anomaly was particularly puzzling as the Lambert targeting task had been successfully executed 35 times previously during this mission.

F/V 49/105		FAULT 1		RR13850CH064		
OGMT	135:03:35:25	OMET	6:03:55:25	SITE TDR	DI 161	GN 011
RGMT	135:03:35:25	D/L GNC	GPC ID 1	SM	026	BF
CRT ID	FAULT	GPC	TIME			
1	PDRS SING WY	4	135:01:52:44.44			
2	PDRS SING WY	4	135:01:52:36.74			
3	PDRS SING WY	4	135:01:44:23.34			
4	PDRS SING WY	4	135:01:42:02.11			
5	G33 RNDZ RADAR	12	134:23:05:54.57			
6	NAV EDIT	12	134:23:01:12.31			
7	S96 PDRS RCH EP	4	134:21:04:55.88			
8	S96 PDRS RCH SP	4	134:21:04:55.88			
9	PDRS SING EP	4	134:21:04:55.88			
→ 10	TGT ITER	12	134:20:39:42.07			
→ 11	TGT ITER	12	134:19:14:04.14			
→ 12	TGT ITER	12	134:18:47:13.13			
→ 13	TGT ITER	12	134:18:30:42.50			
14	G33 RNDZ RADAR	12	134:17:53:29.50			
15	G23 OMS/RCS QTY	12	134:16:26:17.55			
16	S68 CRYO 02	4	134:14:27:13.11			
17	S68 CRYO 02 --	4	134:14:26:54.44			
18	S68 CRYO 02	4	134:14:26:47.30			
19	S68 CRYO 02	4	134:14:26:38.05			
20	S66 CABIN FAN	4	134:14:17:51.03			

Figure 31 Screen print of Mission Control Fault Display listing targeting failures.

Recovery from the Anomaly and Completion of the Flight Day 7 Rendezvous

Mission Control and other shuttle systems specialists continued to discuss the problem as the time for the Ti maneuver approached (Figure 29). Three EVA crew were in the airlock and there was not enough propellant on-board to support both a Ti-Delay (a maneuver to buy time by delaying initiation of an intercept trajectory) and a fourth rendezvous later in the mission. Mission Control personnel had lost confidence in the Lambert targeting software and decided that the rendezvous could be continued if the Ti and subsequent maneuvers were computed by Mission Control and transmitted to the crew. Orbiter and target state vectors from the shuttle GNC computers, which had been improved with radar data, would be used. However, the re-programming of the shuttle GNC computers had erased the statistical information concerning star tracker passes and the previous incorporation of radar data. Mission Control opted for the Ti-Delay maneuver and to fly an additional orbit to provide more time (about 90 minutes) for improving the on-board navigation data using the radar, before an intercept trajectory was initiated.

After the Mission Control computed Ti-Delay was performed (item 7 in Figure 29), two on-board troubleshooting Ti targeting attempts succeeded while another failed. The Ti and subsequent maneuvers were performed using burn solutions voiced to the crew from Mission Control. At orbital sunrise, just before the start of the proximity operations phase, the *Endeavour* commander reported that INTELSAT was in the cross hairs of the Crew Optical Alignment Sight (device on the left side of Figure 27), indicating a nominal approach trajectory for initiating proximity operations (item 12 in Figure 29, Figure 32).

Successful Capture and Repair of INTELSAT On Flight Day 7

Previous shuttle RCS jet plume torques had driven the INTELSAT spin axis nearly 90 degrees out of the orbital plane. The commander rotated *Endeavour* nearly 90 degrees about the roll axis and performed a fly-around to place the spin axis into the payload bay. *Endeavour* was then maneuvered so that the INTELSAT was within reach of the EVA crew (Figure 32). INTELSAT was grabbed (Figure 33), the capture bar was put in place, and the RMS then grappled the INTELSAT and berthed it in the payload bay.

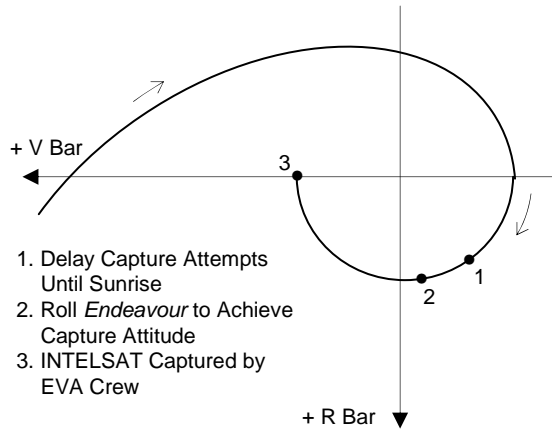

Figure 32 Sketch of proximity operations after the third rendezvous on flight day 7.



Figure 33 Three EVA crew captured INTELSAT on flight day 7.

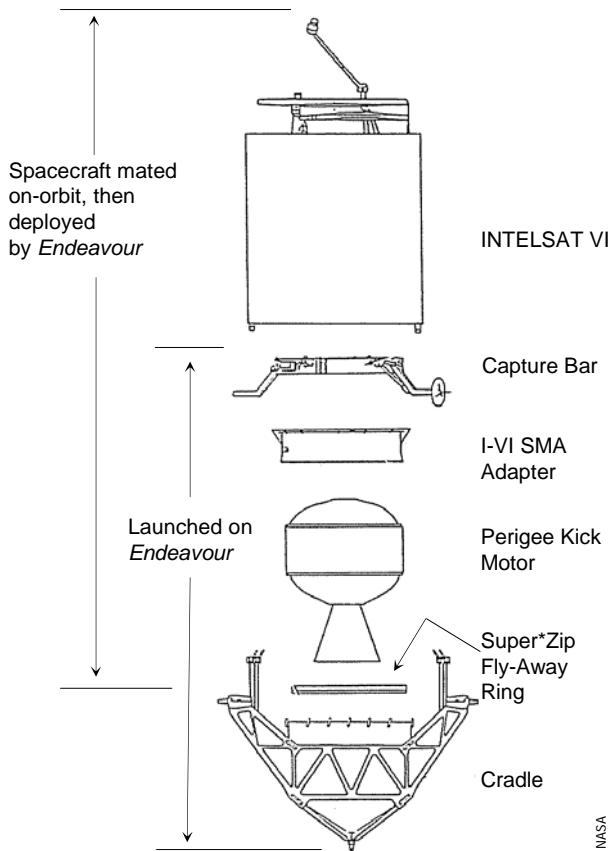
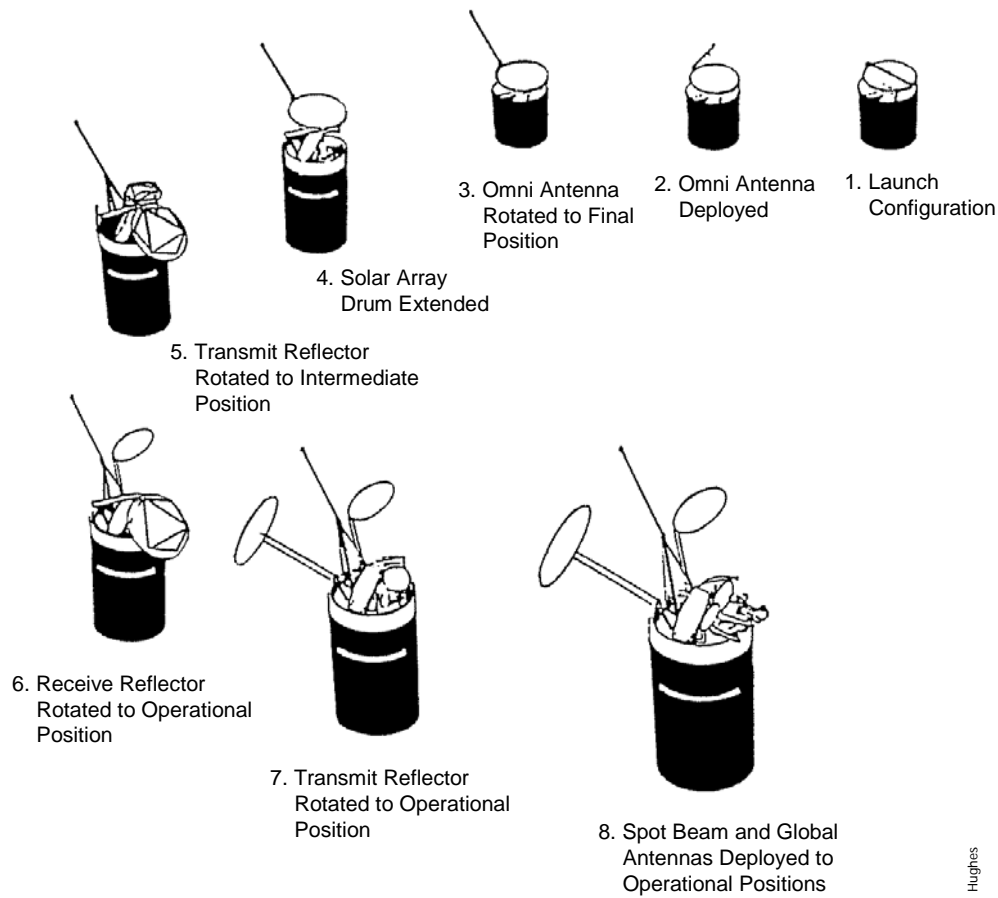

Figure 34 INTELSAT and hardware used for berthing and PKM attachment.

The EVA crew attached a new PKM to the satellite (Figure 34). The INTELSAT was deployed from *Endeavour* (Figure 35). After *Endeavour* had separated to a safe distance, the PKM was successfully fired. The satellite eventually reached geosynchronous orbit and commenced operations (Figure 36, steps 3 through 8).



Figure 35 INTELSAT deployed with a new perigee kick motor.



Hughes

Figure 36 INTELSAT antenna deployment sequence.

Investigation of The Lambert Targeting Anomaly

While the Flight Day 7 rendezvous was still in progress, a software investigation involving several NASA and contractor organizations was initiated.^{16,17} The failure of the targeting algorithm to converge was isolated to the use of one double precision and two single precision parameters in a double precision mid-value selection library function.¹⁸ To ensure the successful completion of the remaining mission activities and the safe return of *Endeavour* to Earth, the orbit and entry GNC software was examined to determine if there were any other cases of mixed precision use that could cause problems. Ascent GNC software was also examined. No other instances of mixed precision use were found.

In 1989, three years before STS-49 flew, it was discovered that a double precision mid-value selection library function actually operated on the three input parameters as if they were single precision. An analysis of all uses of the function in the flight software was performed and the function was corrected so that all inputs were treated as double precision. STS-49 was the first mission to fly a rendezvous after the correction had been made. It should be noted that the targeting failure did not occur before the flight in the extensive software and integrated avionics testing processes (conducted in multiple facilities using shuttle flight computers). The failure did not occur during integrated simulations with Mission Control and the crew in a simulator, nor did it occur in the 35 previous executions of Lambert targeting during STS-49. The investigation also found that the Ti maneuver was the only one susceptible to the anomaly. The mid-course maneuvers could have been targeted on-board rather than by Mission Control.

The next rendezvous mission, STS-56 (April 1993), used the same software version as STS-49. A set of convergence criteria was set to more liberal values to prevent the anomaly from occurring. No targeting failures occurred during the mission. STS-57 (June-July 1993) was the first flight of a new software version that included a source code fix for the STS-49 anomaly and a code change to improve convergence on a burn solution. Lambert targeting software used during the STS-57 retrieval of the European Space Agency EURECA satellite performed with no difficulties.

Keys to the Success of STS-49 and Lessons Learned

The INTELSAT capture and repair, coupled with multiple technical problems that had to be resolved in flight, made STS-49 one of the most challenging space shuttle missions ever flown. One key to successful development and execution of procedural work-arounds to salvage the mission was the existence of a multi-disciplinary flight control team trained in real-time problem analysis and resolution (Figures 37 and 38).¹⁹ The use of the new Payload Bay program and the new laser sensors lowered propellant consumption during proximity operations. This contributed to the successful execution of three rendezvous and three proximity operations phases in the presence of tight propellant budget constraints. A number of important lessons concerning software were learned.

- **Examine And Test Any Changes Made To Code Used Within Iteration Loops.** Changes to library functions or other code used within an iteration loop can alter software functionality or prevent convergence. Convergence characteristics of an iteration algorithm should be tested, documented, and understood over the entire range of iteration parameter values, including values that are not representative of the mission. Use of mixed precision parameters should be avoided.
- **Conduct Thorough, Independent Reviews Of Analysis And Technical Reports.** Limited review by technical and management personnel may not catch subtle technical issues that can later negatively impact flight performance. The increasing complexity of aerospace vehicles requires more specialists to assess questionable performance, impacts of technical issues, and performance impacts of proposed modifications. Independent examination and critique of data and analysis by personnel in multiple organizations is useful for ensuring the quality of performance analysis, risk assessments, requirements, mission planning, test procedures, and mission execution procedures. Results of simulations, flight tests, and anomaly documentation should be made available to all project personnel.
- **Create Legible Software Requirements Documentation For Those Who Are Not Software Developers.** This documentation is used by engineering and operations personnel throughout a flight program for insight into software design and functionality. Well-designed and well-written documentation makes it easier for technical and management personnel to research and understand requirements. This improves the quality performance analysis, issue resolution, testing requirements definition, and procedure development. Document organization, page layout, and type setting should permit the reader to easily read and comprehend the requirements at various levels (line of code, task, module, integrated sets of software). Headings should be easily located visually, as well as through a table of contents. Characteristics of data transferred from module to module should be clearly defined. Flow charts and written descriptions should enable the reader to easily understand where a specific module fits in the overall software architecture, what data it requires, and other tasks dependencies. Declaration of variable types in software requirements should be next to the task in which the variables are used, not in another section of the requirements document.



Figure 37 The STS-49 Mission Control Rendezvous Execute Team (Orbit 1).



Figure 38 The STS-49 Mission Control Planning Team (Orbit 3).

Rendezvous Lambert Targeting Anomaly Before STS-51

The STS-51 mission of *Discovery* concerned the deployment and retrieval of the Orbiting and Retrievable Far and Extreme Ultraviolet Spectrometer Shuttle Pallet Satellite (ORFEUS-SPAS) scientific satellite (Figures 39 and 40), and the deployment of the Advanced Communications Technology Satellite (Figure 40).

This incident concerns a Lambert targeting failure due to a software improvement introduced in response to the STS-49 anomaly. On the evening of Wednesday, September 8, 1993, a Lambert targeting failure (from a different part of the targeting software than the STS-49 anomaly) occurred during Ti targeting in an integrated simulation involving Mission Control and astronauts in the Shuttle Mission Simulator. The simulation used the new software that contained the verified and flight proven code fix for the STS-49 anomaly. Since the launch of STS-51 was scheduled for Sunday, September 12, an extensive investigation effort by multiple organizations was initiated.

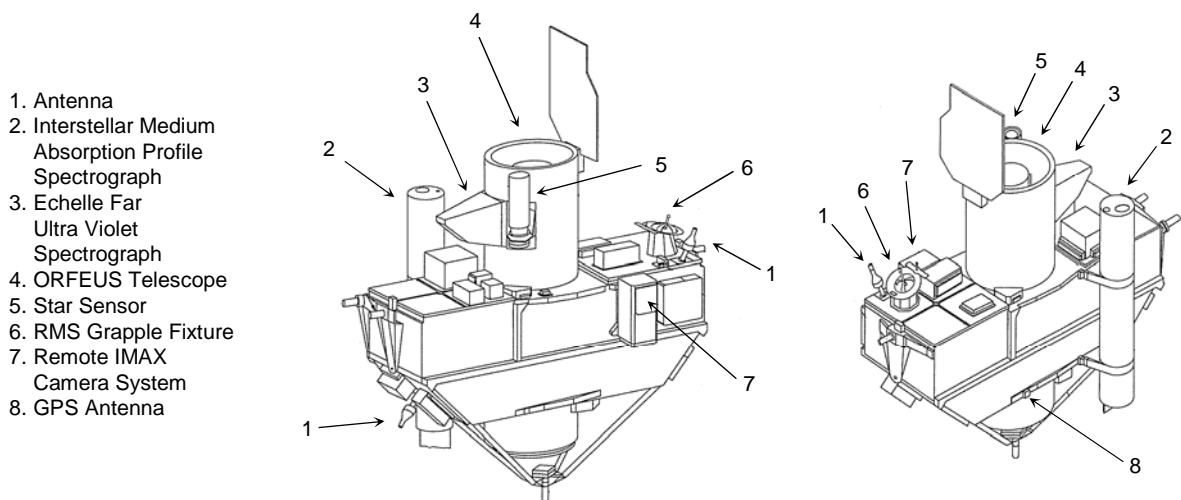

Figure 39 STS-51 ORFEUS-SPAS.

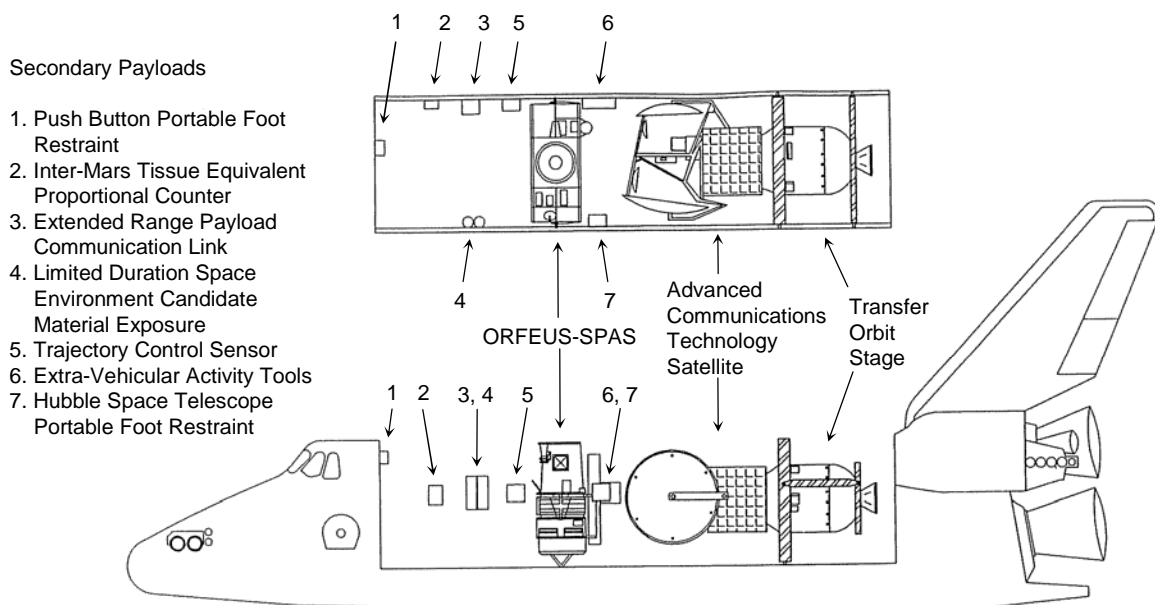

Figure 40 STS-51 Primary and secondary payloads in the payload bay.

Investigation of the Targeting Failure and Development of a Procedural Work-Around

By Friday morning, the failure had been duplicated by the author in the Shuttle Software Production Facility using shuttle software and a shuttle flight computer (Figure 41).¹⁵ Data was distributed to all parties involved in the investigation that morning. By 5 pm on Saturday the 11th, the source of the failure had been identified as a rare numerical condition associated with the convergence improvement code introduced after STS-49. It was limited to rendezvous targeting, would not impact any other software functions or flight phases, and was not a constraint to the upcoming mission. Should the failure occur during the STS-51 rendezvous, a procedural work-around was developed and the STS-51 crew was briefed on the procedure the day before the launch.

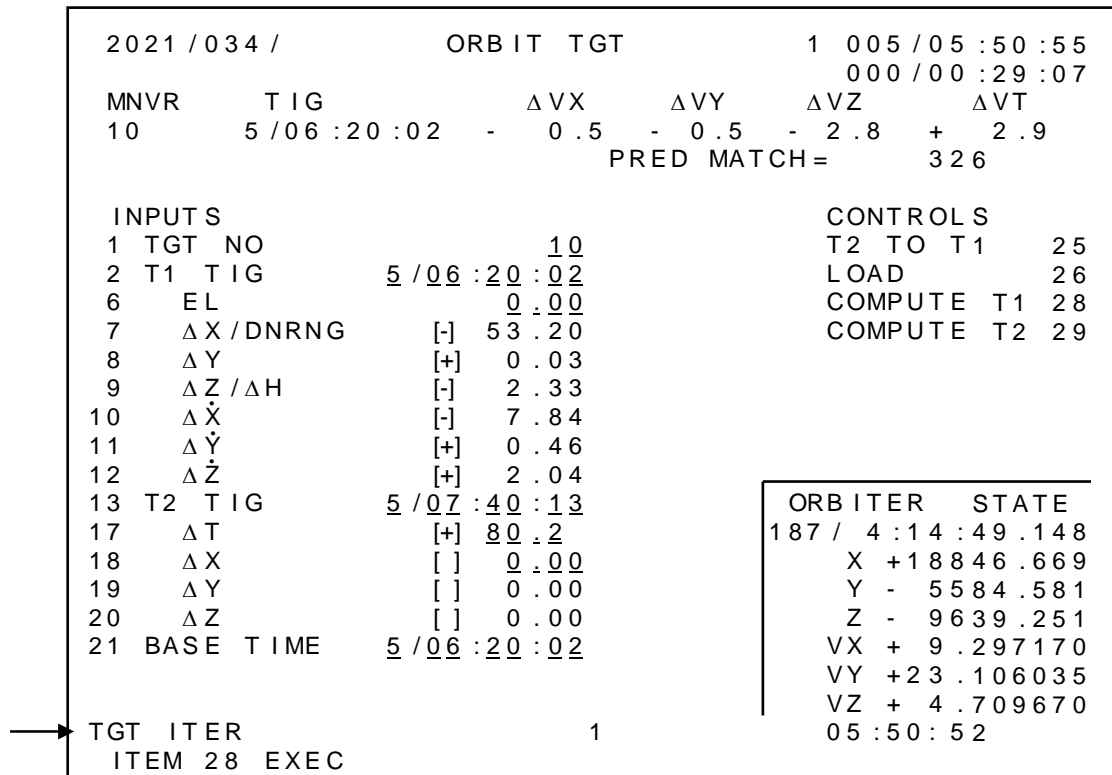

Figure 41 Failed Ti targeting attempt recreated before the 1993 launch of *Discovery* on STS-51.

Correction of the New Targeting Failure

The STS-51 rendezvous with ORFEUS-SPAS was successfully conducted with no targeting failures occurring during the mission (Figures 42 and 43). Post flight, another investigation resulted in a software change to prevent the new anomaly from reoccurring. Analysis showed that the occurrence of this anomaly was less frequent than the STS-49 anomaly. Starting with the first rendezvous mission after STS-49 (STS-56, April 1993) through STS-114 (July-August of 2005), 45 shuttle missions have exercised the Lambert targeting software with no software anomalies occurring in flight. In addition, none have occurred in software testing and pre-mission training simulations since the fall of 1993.

Lessons Learned From the STS-51 Pre-Flight Anomaly

- **Quantify The Benefit Of Proposed Improvements To Software.** Unneeded changes to software to improve performance can introduce technical problems that will later have to be investigated and resolved. Time and effort spent on a “nice-to-have” improvement can reduce resources needed to address higher priority issues. Changes to flight critical software should not be made unless the changes have been verified in off-line simulations and there is an identifiable benefit in terms of performance and risk reduction.

• **Educate Later Generations of Engineers on Theoretical Principals and Requirements Rationale Possessed By Those That Developed The Computer Algorithms.** Many engineers and Mission Control flight controllers worked on the STS-49 and STS-51 investigations that were not involved in the original development of the shuttle rendezvous software in the late 1970s. Much of the theoretical and functional insight that they gained during the investigations has been preserved in improved training materials and Mission Control handbooks. Documentation from the Lambert targeting investigations has been collected and archived to ensure future access.²⁰

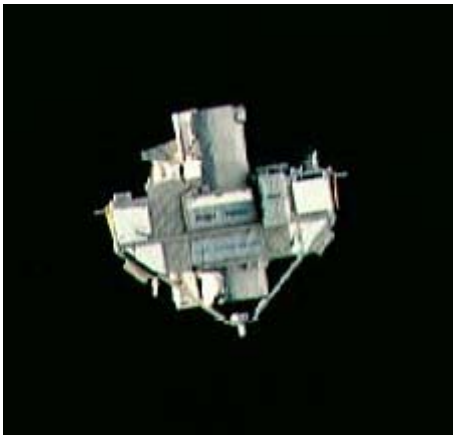

Figure 42 ORFEUS-SPAS after deployment from *Discovery* on flight day 2.

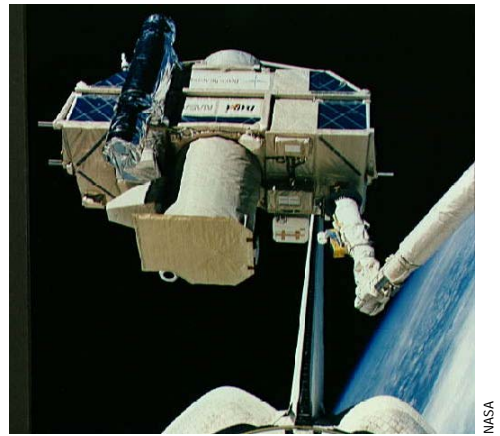

Figure 43 ORFEUS-SPAS after capture by the RMS on flight day 8.

This page intentionally left blank

Zero Doppler Steering Maneuver Anomaly Before STS-59

This anomaly is associated with shuttle flight control system performance in support of the Jet Propulsion Laboratory's Space Radar Laboratory (SRL). The SRL flew in the payload bay of *Endeavour* on STS-59 (April 1994) and STS-68 (September/October 1994). *Endeavour* flew in a 57-degree inclination orbit to map a significant portion of the Earth's surface (Figure 44). To remove the effects of Earth rotation from the radar data, Zero Doppler Steering maneuvers were performed throughout the SRL data collection periods. The 8-degree yaw maneuvers were of long duration (typically around 45 minutes) and were executed at a rate of 0.003 degrees/second.



Figure 44 The Space Radar Lab in the payload bay of *Endeavour*.

Maneuver Fails to Meet Mission Requirements

Before each shuttle mission, integrated mission simulations with flight controllers in Mission Control and astronauts in the Shuttle Mission Simulator are conducted. Several weeks before the launch of STS-59, the Mission Control Guidance and Control officer noted that the length of the Zero Doppler Steering maneuvers were either shorter or longer than expected. For example, one maneuver expected to last 31 minutes took 62 minutes to complete, and another maneuver expected to last 44 minutes was completed in 34 minutes. Were this to occur during flight, much of the radar data would have been corrupted.

Investigation of the Maneuver Failure

Flight controllers contacted shuttle software and flight control system specialists and a discrepancy report was written. An investigation by multiple Shuttle Program organizations quickly identified the problem as a precision loss in a single precision attitude accumulator in the flight control software. Truncation in the accumulator resulted if the accumulated attitude change was above 256 degrees in any component. The anomaly was duplicated in several ground facilities that used shuttle software on shuttle computers or functional equivalents of the shuttle software. The shuttle flight control software was modified to reset all components if the absolute value of any component of the accumulated attitude exceeded 180 degrees.

This flight control system behavior had not been previously observed, as long duration low rate attitude maneuvers of this type had never before been a requirement for a shuttle mission. Previous shuttle attitude maneuvers were shorter in duration and higher in rotational rate. The truncation of digits when above 256 degrees was insignificant compared to the magnitude of maneuvers previously performed by the shuttle during 13 years of missions. However, for Zero Doppler Steering the accuracy loss due to truncation was significant.

Correction of the Software Anomaly

A software fix was implemented and verified before the launch of STS-59. Flight control system performance on both STS-59 and STS-68 was as expected. Zero Doppler Steering successfully removed Earth rotation effects from the radar data. It was also successfully performed in support of the Infrared Spectral Imaging Radiometer flown on STS-85 and the Shuttle Radar Topography Mission flown on STS-99.

Lesson Learned From The STS-59 Anomaly

- **Operation to Meet New Mission Requirements May Involve Performance Under Conditions That the System Was Not Designed to Support.** This can result in performance that does not meet requirements and threatens mission success. New and evolving mission requirements and procedures should be examined and compared to the verified performance envelope of the flight system to determine if additional testing is required.

Excessive Propellant Consumption During Rendezvous On STS-69

STS-69 was the third flight of the Shuttle Pointed Autonomous Tool For Astronomy 201 (SPARTAN-201) and the second of the Wake Shield Facility (WSF) (although WSF was carried on STS-60 but not deployed due to an anomaly). This was the first mission on which two different payloads would be deployed and retrieved.

SPARTAN-201 observations of the solar atmosphere and solar wind were scheduled to occur at the same time as the flight of the Ulysses spacecraft over the north polar region of the sun. SPARTAN was deployed from *Endeavor* on Flight Day 2 and retrieved on Flight Day 4 (Figure 45). Wake Shield was designed to provide a vacuum space environment for growing thin films for future electronic circuits. WSF was deployed on Flight Day 5 (Figure 46) and retrieved on Flight Day 8.



Figure 45 SPARTAN-201 (left) just before it was grappled with the Remote Manipulator System (right) on September 10, 1995.

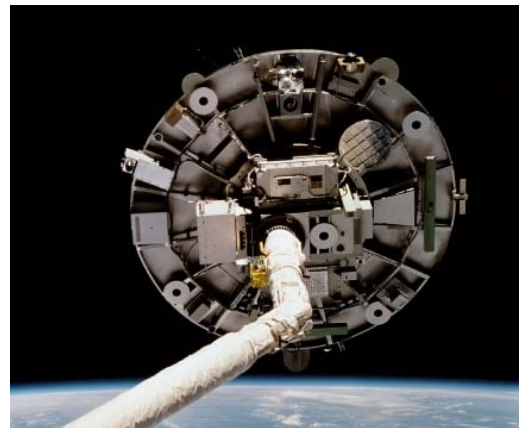

Figure 46 The Wake Shield Facility before deployment using the Remote Manipulator System on September 11, 1995.

Propellant Consumption During the SPARTAN-201 Rendezvous

During execution of the NCC maneuver on the SPARTAN-201 rendezvous 4.3 times as much propellant was used as was predicted before the flight. The desired position for the next burn, Transition Initiation, was missed by 0.96 nautical miles. However, execution of all burns after NCC was as expected, and SPARTAN-201 was successfully retrieved. New procedures to prevent a repeat of the performance problem were created by Mission Control personnel and applied to the rendezvous later in the mission with Wake Shield. All maneuvers during the Wake Shield rendezvous were executed without incident.

Post Flight Investigation

Post flight analysis revealed a performance limitation in a rendezvous software algorithm. The algorithm had been developed in the 1960s for the Apollo vehicles and had been adopted for use in the shuttle software in 1977. The performance limitation was known to Apollo era personnel and shuttle personnel early in the Shuttle Program. However, knowledge of the limitation had not been documented and passed on to newer personnel. The performance limitation had not been encountered on any of the 18 previous shuttle missions that exercised the software.

After the mission an extensive analysis effort was conducted to explore and define the performance envelope of the algorithm. New Mission Control and crew procedures were developed. Algorithm functionality and the performance limitation was documented and incorporated into flight rules, training, and procedures handbooks to ensure that the problem would not be encountered in the future.

Lesson Learned From STS-69

- **Document the theoretical rationale, assumptions made, and performance limitations inherent in software.** Performance limitations of software can exist that users in the original or subsequent application may not be aware of. Such limitations could threaten mission success or safety of flight. Particular care should be used when software from legacy flight programs is applied to a new vehicle. New users of algorithms should be able to track down the historical information concerning algorithm design and performance.

Global Positioning System Receiver And Associated Shuttle Flight Software Anomalies On STS-91

STS-91 (June 1998) was the final flight of a Space shuttle to the Mir space station (Figure 47). *Discovery* returned astronaut Andrew Thomas to Earth after a long duration stay on Mir. This incident concerns GPS receiver and shuttle software anomalies that occurred during the mission. A problem in one system component can result in inappropriate interaction with an interfacing component and trigger undesirable and unanticipated effects that cascade throughout an avionics system. The root causes, manifestations, and vehicle-wide impacts of dysfunctional individual system components are difficult and often impossible to predict.



Figure 47 Mir as seen from *Discovery* on STS-91.

Shuttle Test Flights of the GPS Receiver

In the early 1990s, the Shuttle Program began to study the replacement of the space shuttle's three TACAN entry navigation units with three Global Positioning System (GPS) receivers.²¹ GPS would also be used on-orbit for purposes that did not require precision orbit determination. NASA hoped to reduce development time and costs using an off-the-shelf and in production receiver. After a trade study, a GPS receiver entering production for military aviation applications was selected for the Shuttle Program. The receiver met the requirements of the original customers and has been successfully used in a wide variety of atmospheric flight applications since then.

From 1993 to 1996, a pre-production version of the receiver was flown on seven shuttle missions for data gathering and identification of software modifications to improve receiver performance. Starting with STS-79 in September of 1996, a production receiver modified for the shuttle application was flown on many shuttle missions (Figure 48 and Table 3). The integration architecture enabled the receiver and associated shuttle flight computer software to be flown in a data gathering mode without modification to the existing, proven shuttle navigation system. Flight test results were used to determine what further receiver and shuttle flight computer modifications were necessary so the receiver and associated shuttle computer software could eventually be certified for operational use. From 1993 through 1998, the receiver was interfaced with the Backup Flight System flight computer during ascent and entry and a laptop computer while on-orbit. STS-91 represented the first flight on which the GPS receiver interfaced with the Shuttle's Primary Avionics Software Subsystem (PASS) GNC flight computer during all flight phases. This gave Mission Control personnel access to GPS receiver data in real-time during the orbital phase of the mission.

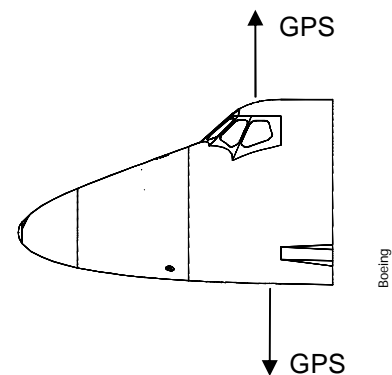

Figure 48 GPS antenna boresights for flights with one GPS receiver.

GPS Receiver and Shuttle Software Anomalies During STS-91

The shuttle GNC flight computer propagates and supplies an aiding state vector to the GPS receiver. The receiver filters it using GPS measurements and returns it as an updated state vector (the GPS state vector) to the shuttle GNC computer (Figure 49). The GPS state vector, if it passes a number of shuttle flight computer quality assurance checks, is then designated as a "selected" GPS state and can be used to replace the current shuttle navigation state vector when required. When the anomalies occurred on STS-91, GPS updates to the shuttle navigation state were inhibited.

If the GPS receiver deems the GPS state vector to be healthy, the shuttle GNC computer uses it to periodically update the current aiding state vector sent to the GPS receiver to limit error growth during state propagation. When an aiding state vector update is performed, a signal is sent to the GPS receiver to indicate that an update has occurred. Upon receipt of this information, the GPS receiver sends an acknowledgement back to the shuttle GNC flight computer.

Table 3 Space Shuttle GPS Test Flights For TACAN Replacement

Shuttle Mission	Year	Orbiter	Shuttle Software Version	GPS Receiver	Receiver Software Version
61	1993	<i>Endeavour</i>	OI-22	3M	002
59	1994	<i>Endeavour</i>	OI-22	3M	002
68	1994	<i>Endeavour</i>	OI-22	3M	003
67	1995	<i>Endeavour</i>	OI-23	3M	003
69	1995	<i>Endeavour</i>	OI-24	3M	003
72	1996	<i>Endeavour</i>	OI-24	3M	003
77	1996	<i>Endeavour</i>	OI-24	3M	003
79	1996	<i>Atlantis</i>	OI-25	MAGR/S	002 *
81	1997	<i>Atlantis</i>	OI-25	MAGR/S	003 *
82	1997	<i>Discovery</i>	OI-25	MAGR/S	003 *
84	1997	<i>Atlantis</i>	OI-25	MAGR/S	004 *
85	1997	<i>Discovery</i>	OI-26A	MAGR/S	004 *
89	1998	<i>Endeavour</i>	OI-26A	MAGR/S	006 *
91	1998	<i>Discovery</i>	OI-26B	MAGR/S-3S	002 †
95	1998	<i>Discovery</i>	OI-26B	MAGR/S-3S	003 †
88	1998	<i>Endeavour</i>	OI-26B	MAGR/S-3S	003 †
96	1999	<i>Discovery</i>	OI-27	MAGR/S-3S	004 †
103	1999	<i>Discovery</i>	OI-26B	MAGR/S-3S	004 †
99	2000	<i>Endeavour</i>	OI-27	MAGR/S-3S	004 †
101	2000	<i>Atlantis</i>	OI-27	MAGR/S-3S	004 †
106	2000	<i>Atlantis</i>	OI-27	MAGR/S-3S	004 †
92	2000	<i>Discovery</i>	OI-27	MAGR/S-3S	004 †
97	2000	<i>Endeavour</i>	OI-27	MAGR/S-3S	004 †
98	2001	<i>Atlantis</i>	OI-28	MAGR/S-3S	004 †
102	2001	<i>Discovery</i>	OI-28	MAGR/S-3S	004 †
100	2001	<i>Endeavour</i>	OI-28	MAGR/S-3S	004 †
104	2001	<i>Atlantis</i>	OI-28	MAGR/S-3S	004 †
105	2001	<i>Discovery</i>	OI-28	MAGR/S-3S	004 †
108	2001	<i>Endeavour</i>	OI-28	MAGR/S-3S	NFP-2 †
109	2002	<i>Columbia</i>	OI-28	MAGR/S-3S	NFP-2 †
110	2002	<i>Atlantis</i>	OI-29	MAGR/S-3S	NFP-2 †
111	2002	<i>Endeavour</i>	OI-29	MAGR/S-3S	NFP-2 †
112	2002	<i>Atlantis</i>	OI-29	MAGR/S-3S	005 †
113	2002	<i>Endeavour</i>	OI-29	MAGR/S-3S	005 †
107	2003	<i>Columbia</i>	OI-29	MAGR/S-3S	005 †
114	2005	<i>Discovery</i>	OI-30	MAGR/S-3S	006 †
121	2006	<i>Discovery</i>	OI-30	MAGR/S-3S	006 †
115	2006	<i>Atlantis</i>	OI-30	MAGR/S-3S	007 †
116	2006	<i>Discovery</i>	OI-30	MAGR/S-3S	007 †

* Single String GPS Receiver Software

† Three String GPS Receiver Software

Near the end of Flight Day 6 (the day after *Discovery* had left the Mir space station), a GPS receiver software anomaly occurred, that triggered a receiver automatic software reset (similar to a “ctrl-alt-delete” on a personal computer). At the same time, the shuttle GNC computer sent an aiding state update indication to the receiver. The GPS receiver did not detect the change in the update command flag, due to the GPS receiver reset in progress, and never sent the GNC computer an acknowledgement that it had performed processing related to the update (Figure 49). The shuttle computer continued to send the update indication. It was not detected by the GPS receiver as the GPS receiver was looking for a change in the update command indication (which had already occurred), rather than testing the value of the command. As a result, future aiding state updates in the shuttle GNC computer did not occur. The old aiding state continued to be propagated in the GNC computer with increasing error and provided to the GPS receiver.

Consequently, after about 8 hours of propagation, the inaccuracy in the aiding vector exceeded computation limits. The GNC computer issued a large number of mathematical conversion errors at a high rate over the avionics system communications bus. The large number of error messages prevented the transmission of shuttle state vectors from the

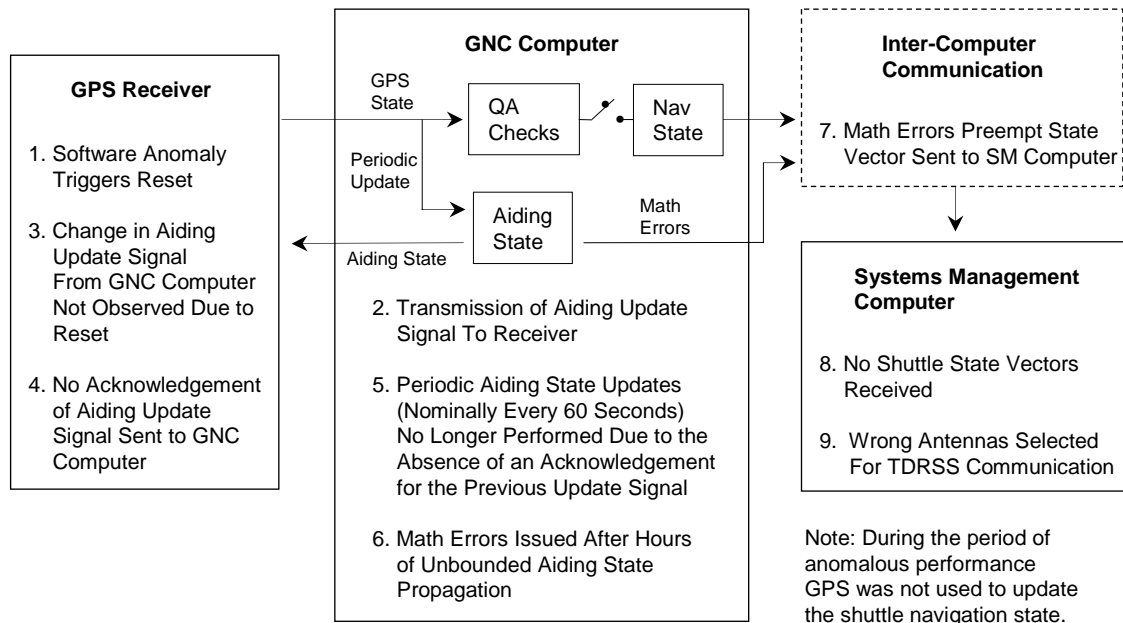

Figure 49 STS-91 GPS and shuttle software anomalies.

GNC flight computer to a Systems Management (SM) computer. These state vectors are used for automatic antenna selection for communication via the Tracking and Data Relay Satellite System (TDRSS) and ground stations. This caused a failure of the SM computer to automatically transition from the TDRSS-West to the TDRSS-East satellite. The SM computer kept selecting an antenna for TDRSS-West, even though it was obscured by the Earth. Antenna selection for ground stations was also corrupted. Mission Control lost communications with *Discovery* during a scheduled crew sleep period.[§] Erratic communication through a ground station began 30 minutes after the initial loss of communication, and communications through TDRSS-West was restored 39 minutes after the outage began.

Shuttle Avionics System Recovery

Manual antenna selection for both TDRSS and ground stations was performed by Mission Control to protect against another communications outage. Mission Control awoke the crew at the normally scheduled wake-up time, about an hour after TDRSS communication was reestablished. The GPS receiver was powered off after a power cycle failed to restore the GPS receiver to proper operation. Software from the GNC and SM computers was transmitted to Mission Control for analysis. The crew activated another shuttle computer loaded with PASS GNC software to replace the one emitting the error messages and powered off the suspect computer. The state vector provided to the SM computer assumed the correct value and proper TDRSS antenna selection occurred. The GPS receiver was powered up for a short time later for a series of tests, but was turned off for the remainder of the flight (including entry) due to the on-orbit anomalies. In the hours after the anomaly, an investigation was conducted that focused on ensuring the anomalies did not result from any generic problems that could impact mission success or safe return of the orbiter and crew. None were found.

Investigation of the GPS Receiver and Shuttle Software Anomalies

The investigation effort involving teams of technical and management personnel from several NASA and contractor organizations continued for the remainder of the mission and also for two months after *Discovery* returned to Earth. Shuttle Program management assigned action items to the teams to conduct a rigorous search for the causes of the GPS receiver, shuttle GNC computer, and SM computer anomalies, as well as any software process inadequacies.

[§] The incident occurred early in the morning Houston time on June 9, 1998. The author was awakened at 1:34 am by a phone call from the Mission Control Flight Dynamics Officer. Many NASA and contractor personnel were called to Mission Control at that time to begin working the problem.

Investigation findings and the corresponding corrective actions were:

- **Finding** - A GPS receiver software anomaly, that had not been observed before, triggered the automatic reset. This caused the receiver software to miss the change in the aiding state update indication.
- **Corrective Action** - A GPS receiver software correction was made and verified through laboratory and later shuttle flight-testing.

- **Finding** - Parallel development of interface software for the GPS receiver and shuttle flight computer resulted in inadequate software requirements. This caused the GPS receiver to miss the aiding state update indication. It also caused the GNC computer to continue transmission of the update flag to the GPS receiver and the GNC computer never updated the aiding state.
- **Corrective Action** - The shuttle GNC computer/GPS receiver interface was “bullet-proofed” from all known or postulated forms of input. Shuttle GNC software interfaces with other shuttle navigation aids were also examined for any similar problems with commanding and data handling. None were found.

- **Finding** - Shuttle flight computer aiding state processing did not protect against aiding state error growth over periods of longer than desirable propagation or aiding state vector updates with state vectors of questionable quality.
- **Corrective Action** - Changes were made to shuttle flight computer aiding state processing to ensure that aiding state updates would occur independent of interaction between the shuttle flight computer with the GPS receiver. In addition, state vectors used for aiding state updates would have to pass additional quality assurance checks.

- **Finding** - Examination of computer communication bus software revealed a requirements deficiency that permitted state vector data sent from the GNC computer to the SM computer to be overwritten by high rate error messages, resulting in a communications loss with *Discovery*.
- **Corrective Action** - The computer communication bus software was modified to ensure error messages would not overwrite data needed for antenna selection.

- **Finding** - An issue identified during testing of shuttle flight computer software supporting GPS was not appropriately processed before flight.
- **Corrective Action** - Improvements were incorporated into the shuttle software testing process.

Following STS-91, extensive ground and flight-testing validated the effectiveness of the GPS receiver and shuttle flight computer software improvements (Table 3 and Figure 50).

Project Changes Resulting From the Investigation

In the fall of 1997, the Shuttle Program had approved the removal of three TACAN units from *Atlantis* and the installation of three GPS receivers. By the time of STS-91 (June of 1998), the TACAN removal and GPS installation had been performed, and *Atlantis* was scheduled to make the first no TACAN, all GPS flight in 1999. As a result of the STS-91 incident the Shuttle Program decided to perform more GPS receiver test flights and additional ground testing before TACAN replacement. Two of the three GPS receivers were removed from *Atlantis* and three TACAN units were reinstalled.

Significant changes were made to the shuttle/GPS integration and certification process. The contract with the GPS vendor was changed so the vendor could participate in the project at a higher level. Expanded vendor involvement after STS-91 brought much needed design insight to the project, that greatly aided issue identification and resolution for STS-91 and subsequent shuttle missions and laboratory testing. Weekly teleconferences involving all project participants were conducted. Face-to-face meetings were held at the Johnson Space Center two to four times a year. Issue tracking and visibility was enhanced. Since the GPS receiver software had originally been developed at government expense, the Shuttle Program was able to get access to the source code. The NASA Independent Verification and Validation contractor began a review of GPS receiver source code which included reviewing changes made in support of the shuttle integration. Shuttle Program personnel gained access to receiver software requirements documents. Additional interim receiver software versions were planned and additional flight and ground testing was conducted to resolve issues and verify software performance. In addition to GPS receiver telemetry sent to Mission Control, a laptop computer was carried on many shuttle flights after STS-91 to record receiver instrumentation port data. This data was instrumental in allowing the GPS receiver vendor to quickly diagnose GPS software problems with complex root causes.

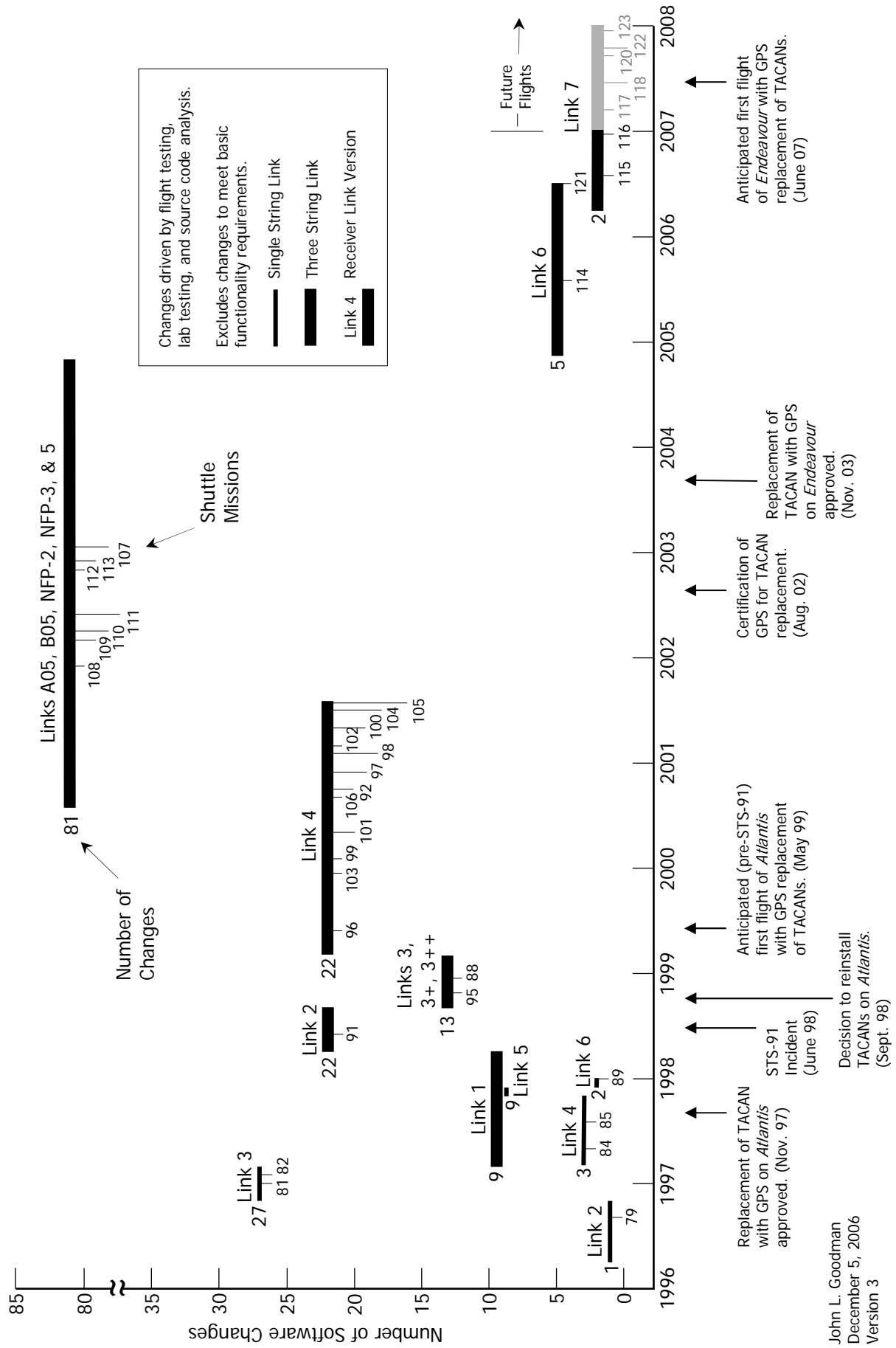

Figure 50 – Number of shuttle GPS receiver software (Link) changes for each software version, 1996 to 2006.

Figure 50 illustrates the number of changes made to the shuttle GPS receiver software (or “link” as it is called within the Shuttle Program) over a 10 year period. The shuttle missions that flew with each software version are indicated. In early 1998, before the flight of STS-91, it was expected that three-string Link 3 would be certified as the GPS receiver software version that would be used on the first no TACAN, all GPS flight. In reality, 4 additional software versions were produced. Before the receiver software could be certified a total of 93 changes (Links 4 and 5) had to be made, tested, and verified. The first all GPS, no TACAN flight will fly with Link 7.

Subsequent GPS Test Flights

Between 1996 and 2005, over 7,000 hours of nominal GPS receiver operating time has been accumulated on shuttle missions flown by *Columbia*, *Discovery*, *Atlantis* and *Endeavour*, each equipped with a single GPS receiver (Table 3 and Figure 50). Receiver and shuttle GNC computer performance in flight and in extensive laboratory tests indicate that software modifications and software process improvements have been effective.

Ionospheric Scintillation

Two articles on threats to the integrity of GPS navigation that appeared in *Aviation Week & Space Technology* in December of 1997 motivated shuttle GPS project members to study ionospheric scintillation.^{22,23} Most personnel were not familiar with this phenomenon and collected and studied published material on scintillation from a variety of industry and academic sources. In addition, contacts were made with members of the navigation and academic communities that were researching scintillation. Although scintillation effects during shuttle GPS test flights had not been noted, personnel became familiar with the phenomenon and how it could impact GPS receiver performance. In April of 1998 Mission Control and other GPS project personnel were briefed on the issue.

On the evening of November 3, 1998, during the flight of STS-95, a Mission Control Ascent/Entry Guidance and Procedures Officer noted velocity noise in GPS data off the coast of South America, during the early evening hours. Additional noise periods were noted during the mission where geographic and temporal characteristics were consistent with ionospheric scintillation. The Shuttle Program was able to quickly conduct an investigation into the velocity noise due to previous research conducted along with the existing contacts in the navigation and scientific communities. The investigation concluded that the noise was due to ionospheric scintillation, but it was not a constraint to the use of GPS data by the shuttle. Mission Control and GPS personnel are trained on the phenomenon and it is tracked in post flight analysis, with two published papers on the topic.^{24,25}

TACAN Replacement By GPS

The GPS receiver and associated shuttle computer software was finally certified for TACAN replacement in August of 2002, over three years after the original target date. On October 23, 2003, the Shuttle Program approved the removal of the three TACAN units from *Endeavour* and the installation of two additional GPS receivers. The orbiters *Atlantis* and *Discovery* most likely will continue to fly with three TACAN units and one GPS receiver due to the accelerated end of the Shuttle Program. Starting with STS-121, an operational ramp-up of increasing GPS use in flight will lead to parallel processing of TACAN and GPS during entry by *Atlantis* and *Discovery*. The first all GPS, no TACAN flight of *Endeavour* will occur after the operational ramp-up and is currently scheduled for STS-116.

Lessons Learned From STS-91 and the Shuttle GPS Project

Since 1998, lessons and experiences from the shuttle GPS project have been disseminated internally within the Shuttle Program and have also been the subject of several publications available outside the Shuttle Program (Table 4). A set of GPS lessons learned was submitted to the NASA Public Lessons Learned System in June of 2002. A compilation of lessons learned and experiences was also published as a NASA contractor report.^{¶26} A summary of some of those lessons follows.

[¶] Another NASA report, *Three Years of Global Positioning System Experience on International Space Station*, was also published covering lessons learned from the International Space Station GPS Project.²⁷

Table 4 Publications Concerning the Space Shuttle GPS Project

Date	Title	Conference or Publication
Oct. 1999	Shuttle GPS Upgrade COTS/MOTS Issues & Lessons Learned*	NASA Avionics Technology Working Group
Oct. 2000	Scintillation Effects On Space Shuttle GPS Data*	26 th Joint Services Data Exchange and GPS Users Conference
Jan. 2001	Scintillation Effects On Space Shuttle GPS Data [†]	ION National Technical Meeting
Jan. 2001	Space Shuttle Navigation in the GPS Era	ION National Technical Meeting
Aug. 2001	Global Scale Observations Of Ionospheric Instabilities From GPS In Low Earth Orbit	AIAA Space 2001 Conference
Sept. 2001	Quantifying GDOP Degradations Caused by Removing Satellites from a GPS Constellation	ION GPS 2001 Conference
May 2002	Lessons Learned From Flights of "Off the Shelf" Aviation Navigation Units on the Space Shuttle*	Joint Navigation Conference
Oct. 2002	Parallel Processing: GPS Augments TACAN in the Space Shuttle	GPS World Magazine
Nov. 2002	GPS In Earth Orbit – Experiences From The Space Shuttle, International Space Station And Crew Return Vehicle Programs	Core Technologies for Space Systems Conference
Feb. 2003	The Space Shuttle and GPS – A Safety-Critical Navigation Upgrade	2nd International Conference on COTS-Based Software Systems
May 2003	A Software Perspective On GNSS Receiver Integration and Operation	International Space University Conference on Satellite Navigation Systems
Oct. 2003	Lessons Learned From Flights of "Off the Shelf" Aviation Navigation Units on the Space Shuttle [‡]	NASA Public Lessons Learned System, Entry 1370
July 2004	A GPS Receiver Upgrade For The Space Shuttle – Rationale And Considerations	40th AIAA/ASME/SAE/ASEE Joint Propulsion Conference
Jan.-Feb. 2005	Ionospheric Instability Observed in Low Earth Orbit Using Global Positioning System	AIAA Journal of Spacecraft and Rockets
March 2005	Application of GPS Navigation to Space Flight	IEEE Aerospace Conference
Nov. 2005	GPS Lessons Learned From The ISS, Space Shuttle, and X-38	NASA Contractor Report CR-2005-213693

* Limited distribution

[†] Derivative work

[‡] Submitted on June 11, 2002. Approved for inclusion on October 20, 2003.
<http://www.nasa.gov/offices/ocel/llis/home/index.html>

• **Judging The Maturity Of Off-The-Shelf Technology Can Be Difficult.** False and simplistic perceptions of the maturity or flexibility of off-the-shelf technology can result in higher risk of budget problems, schedule slips, and late discovery of technical issues. A close relationship with the vendor, other users of the technology, and consultants early in a project can help a systems integrator identify potential challenges. The implications of software reuse should be identified and understood when formulating requirements for resources and schedule and during risk identification.²⁸ Schedule and resources should include interim software versions to allow issues to be discovered and resolved before a mission is flown.

• **Investigate The Original Requirements And Operating Environment For Any Off-The-Shelf Hardware And Software.** Introduction of off-the-shelf hardware and software into a new operating environment can lead to manifestation of issues that impact unit and integrated system performance. Performance problems that are of concern in a new application may not have been an issue for the original integrator and previous users of the unit. The vendor can provide insight into original unit requirements, functionality, and operating environment that can reduce risk during the requirements definition, testing, and mission execution phases of a program.

• **Document Assumptions Made About Operation And Performance of Off-the-Shelf Hardware and Software.** Lack of visibility into software requirements and functionality can force requirements developers for other parts of the avionics system to make assumptions. If incorrect, these assumptions can result in software anomalies and overall poor performance during testing and mission execution. Any assumptions made should be documented and remain visible to project participants until the issue is resolved either through testing (both stand-alone and integrated) or acquisition of detailed information about hardware and software functionality. Ramifications of faulty assumptions should be understood.

• **Understand The Limitations Of The Simulation Environment.** Test equipment features may limit the duration and fidelity of testing. This restricts the ability of the project to subject avionics to conditions representative of the flight environment, increasing the possibility of technical issues arising during flight. Limitations in simulator modeling should be documented and understood so risks can be identified and appropriate changes made to test plans and facilities.

• **Compare Test Results To Interface Requirements Documentation.** An inaccurate Interface Control Document (ICD) can result in requirements deficiencies in other parts of the integrated system. Faulty analysis of test data and development of incorrect operational procedures can also occur. All interfaces should be thoroughly tested. Particular attention should be paid to software conditions that could prevent the receipt or acknowledgement of commands and data. Changes to the ICD or ICD issues arising from testing and inspections of code and requirements should be visible to all personnel. Accurate and up-to-date interface documentation should be available to software requirements developers.

Overall Lessons Learned

A number of lessons learned apply to most of the incidents discussed in this report. These are:

- **Collect, Study, And Apply Lessons Learned And Experiences From Other Projects And Flight Programs.** Risks to technology integration, resources and schedule may not be effectively mitigated if lessons from other programs are not studied and heeded. Technical and organizational causes of problems encountered tend to be common across a wide range of disciplines in industry. Acquisition and dissemination of well-written lessons learned and formal accident investigation reports can help technical and management personnel identify opportunities for improvement at both the technical and management levels.
- **Conduct Comprehensive Integrated Testing Before Flying.** Software intensive components in an integrated system can possess requirements deficiencies that cause poor performance, leading to a failure to meet mission objectives. These issues may not be detectable during stand-alone testing of individual units. Mission requirements and procedures should be examined to determine if additional testing is required to cover flight system operations under non-verified conditions.
- **Plan For Adequate Time And Number of Personnel To Analyze Flight And Ground Test Data.** Subtle performance issues may be detectable in test data that has not been examined, or only examined in a cursory manner. Prompt and thorough analysis can catch software, hardware, and requirements problems early enough to permit resolution without risking project success.
- **Create And Maintain Rigorous Documentation Of Issues Identified In Testing And During Flight.** A failure to appropriately document and call attention to potential system performance issues can threaten mission success. All test and flight data should be examined and any unexplained issues should be documented and visible to project participants. Anomaly documentation, closure rationale, and supporting data should be archived in a manner that facilitates preservation and easy retrieval. Development and certification processes for hardware and software should be closed loop in nature, enabling those concerned with anomalies to track issue status and closure rationale. Disposition of past issues that did not result in proven software fixes should be reexamined for continued validity as in software regression testing. Effective knowledge capture and management increases the skill level within a project and results in more effective and timely prevention, identification, and resolution of anomalies.²⁰
- **Permit Lateral Communication Between Technical Personnel Across Organizational Boundaries.** Restrictions on communication stemming from budget concerns, schedule concerns, and real or perceived organizational barriers can lead to inadequate project, hardware, and software requirements. Regular contacts between project personnel from various organizations enables participants to better work together to identify and resolve technical issues in a timely manner.
- **Communicate Frequently and Openly On Project Status.** Project content increase (additional requirements, anomaly resolution efforts, etc.) and late identification of technical issues can create compressed schedules late in a project and negatively impact resources and schedule performance, software quality, as well as project success. Project and program management should have access to status, requirements, job content, ground rules, and assumptions of all organizations when assessing project status and assessing technical, resource and schedule risk.
- **Understand and Clearly Define The Responsibilities, Ground Rules, And Authority Of Boards, Teams, And Panels.** Poorly defined processes can prevent technical, cost and schedule concerns from receiving adequate attention in a timely manner. Participants should have a thorough working knowledge of configuration control and processes for hardware and software in the flight system and supporting ground test facilities. Communications paths and organizational interfaces should be formally documented. The actual practice and documentation of software and hardware processes should be periodically reviewed for consistency. Any deviation from formally documented practices should be examined to determine if formal procedures should be improved, or if deviation from the documented process increases technical risk.[#]

[#] In his study of the 1994 friendly fire shoot down of U.S. Army Black Hawk helicopters over the northern Iraqi no-fly zone, Dr. Scott A. Snook defined *practical drift* - "the slow, steady uncoupling of local practice from written procedure" to be a factor in the organizational, communications, and procedural failures that led to the tragedy.³

• **Train Project Personnel to Develop Operational Work-Arounds in Response to Anomalies.** Undiscovered software anomalies can still exist after intensive ground testing and flight experience. Successful ground and flight tests can lead to a false sense of security about software maturity. Some software anomalies will manifest only under specific and rare numerical conditions. Personnel trained to perform creative problem solving and communication in an integrated team environment can respond rapidly to unexpected events that threaten mission success. For mission critical situations where a software application failure can result in mission failure, operational workarounds should be developed and validated before flight.

Conclusion

With the potential of new mission objectives and capabilities comes the challenge of integrating, certifying, and successfully flying missions using both off-the-shelf products and new technologies that are software intensive. Rigorous processes for requirements development, documentation of performance limitations, software and hardware development, testing, and incorporation of lessons learned are required to permit early detection of performance issues and identification of risk to resources and schedule.

Space missions are often accompanied by anomalies, even if appropriate steps are taken to mitigate risk. Flexibility in operations concepts, vehicle design, mission design, and resource planning permits effective recovery from anomalous performance. Members of integrated interdisciplinary teams who are skilled at communication, problem analysis, and resolution enable mission objectives to be met. A flight program that possesses these characteristics will be poised to achieve mission success.

This page intentionally left blank.

References

1. *Report of the Presidential Commission on the Space Shuttle Challenger Accident*, U.S. Government Printing Office, Washington, DC, June 6, 1986.
2. *Columbia Accident Investigation Board Report*, Volume I, U.S. Government Printing Office, Washington, DC, August 2003.
3. S. A. Snook, *Friendly Fire – The Accidental Shootdown of U.S. Black Hawks Over Northern Iraq*, Princeton University Press, Princeton, NJ, 2000.
4. W. H. Starbuck and M. Farjoun (editors), *Organization At The Limit – Lessons From The Columbia Disaster*, Blackwell Publishing, Malden, MA, 2005.
5. N. G. Leveson, “The Role of Software in Spacecraft Accidents,” *ALAA Journal of Spacecraft and Rockets*, Vol. 41, No. 4, July-August 2004, pp. 564-575.
6. D. Vaughan, *The Challenger Launch Decision*, The University of Chicago Press, Chicago, IL, 1996.
7. D. Vaughan, “The Trickle-Down Effect: Policy Decisions, Risky Work, and the Challenger Accident,” *California Management Review*, Vol. 39, No. 2, Winter 1997, pp. 80-102.
8. G. Reeves and T. Neilson, “The Mars Rover Spirit FLASH Anomaly,” *2005 IEEE Aerospace Conference*, IEEE, New York, NY, 2005.
9. *SOHO Mission Interruption Joint NASA/ESA Investigation Board Final Report*, August 31, 1998.
10. *The NEAR Rendezvous Burn Anomaly of December 1998*, Final Report, Johns Hopkins University Applied Physics Laboratory, November 1999.
11. J. L. Goodman, “History of Space Shuttle Rendezvous and Proximity Operations,” *ALAA Journal of Spacecraft and Rockets*, Vol. 43, No. 5, Sept.-Oct. 2006, pp. 944-959.
12. P. A. Donatelli, et al., “Intelsat VI Reboost Mission Perigee Kick Motor,” *ALAA/SAE/ASME/ASEE 29th Joint Propulsion Conference and Exhibit*, AIAA, Reston, VA, 1993.
13. L. Virdee, et al., “Intelsat VI (F-3) Reboost Mission,” *14th International Communications Satellite Systems Conference and Exhibit*, 1992.
14. F. Clark, P. Spehar, H. Hinkel, and J. Brazzel, “Laser-Based Relative Navigation and Guidance for Space Shuttle Proximity Operations,” *Guidance and Control 2003, Advances in the Astronautical Sciences*, Vol. 113, Univelt, San Diego, CA, 2003.
15. William “Bo” Davidson and William “Bill” Ferry, “The Legacy of the Software Production Facility Simulator for Shuttle Flight Software,” *ALAA Modeling and Simulation Technologies Conference and Exhibit*, AIAA, Reston, VA, 2006.
16. “NASA Will Modify Rendezvous Software To Avoid Repeat of Endeavour Problem,” *Aviation Week and Space Technology*, June 8, 1992, p. 69.
17. C. Covault, “Mission Control Saved Intelsat Rescue From Software, Checklist Problems,” *Aviation Week and Space Technology*, May 25, 1992, pp. 78-79.
18. *An Assessment Of Space Shuttle Flight Software Development Processes*, National Research Council, National Academy Press, January 1993.
19. M. F. Machula and G. S. Sandhoo, “Rendezvous and Docking for Space Exploration,” *1st Space Exploration Conference: Continuing the Voyage of Discovery*, AIAA, Reston, VA, 2005.
20. J. L. Goodman, *Knowledge Capture and Management for Space Flight Systems*, NASA Contractor Report NASA/CR-2005-213692, NASA Johnson Space Center, October 2005. See the NASA Technical Reports server at <http://ntrs.nasa.gov/>, or the Johnson Technical Reports server at <http://ston.jsc.nasa.gov/collections/TRS/>.
21. J. L. Goodman, “Space Shuttle Navigation in the GPS Era,” *Proceedings of the Institute of Navigation National Technical Meeting*, Institute of Navigation, Fairfax, VA, 2001.
22. B. D. Nordwall, “GPS Success Sparks New Concerns For Users,” *Aviation Week & Space Technology*, December 1, 1997, pp 58-60.
23. B. D. Nordwall, “Solar Storms Threaten GPS Reception,” *Aviation Week & Space Technology*, December 1, 1997, pp 61-62.
24. J. L. Goodman and L. Kramer, “Scintillation Effects On Space Shuttle GPS Data,” *Proceedings of the ION 2001 National Technical Meeting*, Institute of Navigation, Fairfax, VA, 2001.
25. L. Kramer and J. L. Goodman, “Ionospheric Instability Observed in Low Earth Orbit Using Global Positioning System,” *ALAA Journal of Spacecraft and Rockets*, Vol. 42, No. 1, January-February 2005, pp. 124-131.
26. J. L. Goodman, *GPS Lessons Learned From The ISS, Space Shuttle and X-38*, NASA Contractor Report NASA/CR-2005-213693, NASA Johnson Space Center, November 2005. See the NASA Technical Reports server at <http://ntrs.nasa.gov/>, or the Johnson Technical Reports server at <http://ston.jsc.nasa.gov/collections/TRS/>.
27. S. Gomez, *Three Years of Global Positioning System Experience on International Space Station*, NASA Technical Publication NASA/TP-2006-213168, NASA Johnson Space Center, August 2006. See the NASA Technical Reports server at <http://ntrs.nasa.gov/>, or the Johnson Technical Reports server at <http://ston.jsc.nasa.gov/collections/TRS/>.
28. N. G. Leveson and K. A. Weiss, “Making Embedded Software Reuse Practical and Safe,” *ACM SIGSOFT Software Engineering Notes*, Vol. 29, Issue 6, November 2004, pp. 171 – 178.

REPORT DOCUMENTATION PAGE			Form Approved OMB No. 0704-0188		
Public reporting burden for this collection of information is estimated to average 1 hour per response, including the time for reviewing instructions, searching existing data sources, gathering and maintaining the data needed, and completing and reviewing the collection of information. Send comments regarding this burden estimate or any other aspect of this collection of information, including suggestions for reducing this burden, to Washington Headquarters Services, Directorate for Information Operations and Reports, 1215 Jefferson Davis Highway, Suite 1204, Arlington, VA 22202-4302, and to the Office of Management and Budget, Paperwork Reduction Project (0704-0188), Washington, DC 20503.					
1. AGENCY USE ONLY (Leave Blank)	2. REPORT DATE January 2007	3. REPORT TYPE AND DATES COVERED NASA Contractor Report			
4. TITLE AND SUBTITLE Lessons Learned From Seven Space Shuttle Missions			5. FUNDING NUMBERS		
6. AUTHOR(S) John Goodman, United Space Alliance					
7. PERFORMING ORGANIZATION NAME(S) AND ADDRESS(ES) Lyndon B. Johnson Space Center Houston, Texas 77058			8. PERFORMING ORGANIZATION REPORT NUMBERS S-994		
9. SPONSORING/MONITORING AGENCY NAME(S) AND ADDRESS(ES) National Aeronautics and Space Administration Washington, DC 20546-0001			10. SPONSORING/MONITORING AGENCY REPORT NUMBER CR-2007-213697		
11. SUPPLEMENTARY NOTES					
12a. DISTRIBUTION/AVAILABILITY STATEMENT Available from the NASA Center for AeroSpace Information (CASI) 7121 Standard Hanover, MD 21076-1320 Category: 18			12b. DISTRIBUTION CODE		
13. ABSTRACT (Maximum 200 words) Much can be learned from well-written descriptions of the technical and organizational factors that lead to an accident. Subsequent analysis by third parties of investigation reports and associated evidence collected during the investigations can lead to additional insight. Much can also be learned from documented close calls that do not result in loss of life or a spacecraft, such as the Mars Exploration Rover Spirit software anomaly, the SOHO mission interruption, and the NEAR burn anomaly. Seven space shuttle incidents fall into the latter category: Rendezvous Target Failure On STS-41B; Rendezvous Radar Anomaly and Trajectory Dispersion-STS-32 ;Rendezvous Lambert Targeting Anomaly-STS-49; Rendezvous Lambert Targeting Anomaly-STS-51; Zero Doppler Steering Maneuver Anomaly-STS-59; Excessive Propellant Consumption During Rendezvous-STS-69; Global Positioning System Receiver and Associated Shuttle Flight Software Anomalies-STS-91 Procedural work-arounds or software changes prevented them from threatening mission success. Extensive investigations, which included the independent recreation of the anomalies by multiple Shuttle Program organizations, were the key to determining the cause, accurately assessing risk, and identifying software and software process improvements. Lessons learned from these incidents not only validated long-standing operational best practices, but serve to promote discussion and mentoring among Program personnel and are applicable to future space flight programs.					
14. SUBJECT TERMS Spacecraft Performance, spacecraft rendezvous, spacecraft guidance			15. NUMBER OF PAGES 52	16. PRICE CODE	
17. SECURITY CLASSIFICATION OF REPORT Unclassified	18. SECURITY CLASSIFICATION OF THIS PAGE Unclassified	19. SECURITY CLASSIFICATION OF ABSTRACT Unclassified	20. LIMITATION OF ABSTRACT Unlimited		
