

PART VII

SPACE VEHICLE CONTROL SYSTEMS

by

Dr. Wallace E. Vander Velde

DR. WALLACE E. VANDER VELDE

Professor, Dept. of Aeronautics and Astronautics  
Massachusetts Institute of Technology

Dr. Wallace E. Vander Velde is an Associate Professor of Aeronautics and Astronautics and Consultant to the Instrumentation Laboratory at Massachusetts Institute of Technology. In his academic position he is an authority on automatic control systems for fixed wing aircraft, helicopters, missiles, satellites, and space vehicles. At the Instrumentation Laboratory he is working with the Apollo Spacecraft Guidance and Navigation Group.

Dr. Vander Velde was born June 4, 1929, at Jamestown, Michigan. He received the Bachelor of Science degree in Aeronautical Engineering from Purdue University in 1951. Following military service, in 1953, he entered M. I. T. as a graduate student and received the degree of Doctor of Science in Instrumentation in 1956.

From 1956 to 1957, Dr. Vander Velde was director of applications engineering for the GPS Instrument Co., Inc., Newton, Massachusetts. He returned to M. I. T. in 1957 as Assistant Professor of Aeronautical Engineering and was appointed Associate Professor of Aeronautics and Astronautics in 1961 and Professor of Aeronautics and Astronautics in June, 1965.

## Part VII

### SPACE VEHICLE FLIGHT CONTROL

#### INTRODUCTION

The development of the theory and practice of automatic control has to a large extent gone hand in hand with the development of aerospace flight control systems. Although the earliest application of feedback control as a deliberately conceived and consciously-applied technique preceded the invention of the airplane by about 50 years, it was the exacting requirements of aircraft flight control which for years made the greatest demands on the developing theory of feedback control and which stimulated much of its growth. In recent years, the advance of "modern" control theory has been led in large part by workers responding to the need for more sophisticated control theories and techniques for application to aerospace flight control problems. The requirements for control efficiency, accomodation of changing controlled-member characteristics, and reliable control in complicated and demanding situations have resulted in a far broader application of optimal controls, adaptive controls, and digital-computer control systems to the problems of aerospace vehicle flight control than to any other area of application.

Aerospace flight control problems are not only demanding, but quite diverse. Among the many different phases of a space vehicle mission beginning with lift-off from a launching pad and ending perhaps with a return to a designated landing point on Earth, one can identify three major classes of flight control problems:

Powered flight control - control of the attitude and flight path of the vehicle while thrusting.

Coasting flight control - control of the attitude of the vehicle while coasting in free space.

Atmospheric flight control - control of the attitude and flight path of the vehicle while gliding in an atmosphere.

The nature of the control problems in these different situations is very different. The environment in which the vehicle operates, the requirements on the control systems, the sources of reference information and of control torques are all quite

different. But a single space vehicle operates under all of these conditions during the course of a mission and it is to be hoped that the different control problems will not have to be solved one at a time in isolation. The design of an over-all control system which performs well in each phase of the mission, using common equipment wherever possible, and which is in addition integrated efficiently with the guidance and navigation system constitutes a most challenging engineering problem.

In the following chapters, the major characteristics of the control problems in each of these classes is discussed in turn.

## CHAPTER VII - 1

### POWERED FLIGHT CONTROL

#### INTRODUCTION

The function of the powered flight control system is to orient the vehicle thrust acceleration vector in response to commands generated by the guidance system. This function is required during each of the powered flight phases of a mission. These phases might include:

- Boost from the launching pad into a parking orbit
- Acceleration into the destination transfer trajectory
- Midcourse velocity corrections
- Deceleration into an orbit around the destination planet or moon
- Powered descent to the planet or moon
- Comparable phases in the return flight

The thrust acceleration vector is, on the average, oriented in the vicinity of the vehicle longitudinal axis. Thus powered flight control is primarily a problem in attitude control. This problem will be discussed first as it relates to two means of generating the required control moments. Then in the following section, some additional considerations involved in acceleration vector control will be discussed.

#### ATTITUDE CONTROL WITH A GIMBALED ENGINE

With a rocket engine providing a large force which acts on the vehicle, the most evident source of large control moments is the deflection of the direction of this force so it has some moment arm with respect to the vehicle center of mass. This can be conveniently accomplished in the case of a liquid-fueled rocket by mounting the engine on gimbals and rotating it. A solid-fuel rocket requires rotation of the thrust direction with respect to the engine itself. This has been accomplished by different means; among them are jet vanes, jetavators, rotating canted nozzles, and secondary fluid injection. The present discussion supposes a liquid-fueled rocket with a gimbal-mounted engine.

The very first flight control problem encountered in a space mission is probably the most difficult - the control of the unstable, elastic vehicle in its ascent through the gusty atmosphere. In this phase the configuration of the vehicle is largest, the frequencies of body bending and fuel sloshing oscillations are lowest, and the need for control system gain and bandwidth is most critical due to the requirements of stabilizing the aerodynamically unstable vehicle and reducing structural loads due to wind disturbances. In most of the powered flight phases following this, there is no atmosphere to contend with and the vehicle configuration is smaller due to the separation from one or more stages. This would not be true if in-orbit assembly of separately-boosted payloads were employed.

The most important requirements of the attitude control system during atmospheric exit may be summarized as:

- Maintain vehicle stability
- Provide adequate performance for execution of commands
- Provide adequate alleviation of gust loads
- Make reasonably efficient use of control action
- Maintain simplicity and reliability

The first requirement dominates the design of this system. For early analysis one might very well model the vehicle and its control system as quasi-stationary and linear. If so, one has only the classical problem of the stability of a linear, invariant feedback system - and the problem would be simple were it not for the very complicated nature of the vehicle being controlled. The basic rigid vehicle is unstable in the atmosphere because of the required distribution of area and mass. It could be stabilized aerodynamically by the addition of fins at the rear of the vehicle, but the additional weight and drag would incur too dear a performance penalty. So the alternative of active stabilization through control system feedback is almost universally preferred. This places a lower bound on control system gain for static stability: the restoring control moment due to a rotation of the vehicle must be greater than the diverging aerodynamic moment due to that rotation.

But this requirement of high gain for static stability is in conflict with the requirement of low gain for dynamic stability. The dynamic stability problem is complicated by the fact that the large vehicle is by no means rigid. The launch configuration consists of a number of vehicle stages coupled with light-weight interstage structure. Significant bending occurs at these coupling points.

Further, each stage is designed as light-weight as possible with the major requirement being to carry axial compressive loads. The resulting structure has appreciable bending elasticity. Still further non-rigid-body behavior is due to fuel and oxydizer sloshing in their tanks and localized bending of the structure between the points of engine gimbal mounting and gimbal actuator attachment.

The primary body bending deflections are decomposed for analytic purposes into a series of normal modes of oscillation. Each mode has a characteristic frequency and mode shape. These resonant modes are very lightly damped. An idealized picture of a fundamental or first order bending mode is shown in Fig. VII-1. The body centerline, deflected according to the first order mode shape, is shown with an undeflected body reference line. The two points which do not translate in this mode of oscillation are called nodes; the point of greatest translation, which is also the point of zero rotation, is called the antinode. The engine gimbal deflection,  $\delta$ , is measured and controlled with respect to the deflected body. Also, the body attitude is indicated by an instrument located at a particular body station such as that shown on the figure. It will indicate the local body angle with respect to the inertial reference line; in Fig. VII-1, this angle is  $\theta + \phi$ . Additional higher ordered bending modes may be excited simultaneously. The body translational or rotational deflection at any station is the sum of the deflections in the different modes.

It is clear that if the control system bandwidth extends to the frequency of a particular bending mode, the effect of the control feedback can either tend to stabilize or destabilize the mode. Consider as an example just the effect of attitude rate feedback on the mode shown in Fig. VII-1. We see that for gross vehicle stability the sense of the rate feedback to gimbal angle must be positive. That is, a positive  $\dot{\theta}$  should cause a positive engine deflection,  $\delta$ , which will result in a control moment tending to reduce the angular velocity. But now a positive bending rate  $\dot{\phi}$  which is also sensed by the indicator also causes a positive increment in engine deflection,  $\delta$ , and this produces a normal force component on the body which tends to further bend the body in the same sense. For the configuration shown then, with the engine behind the rear node and the rate indicator forward of the antinode, in-phase rate feedback at the first bending frequency tends to destabilize the mode. If either the engine were forward of the rear node, or the rate indicator were behind the antinode, but not both, such feedback would tend to stabilize the mode. Alternatively, for the configuration shown, rate feedback would stabilize the bending mode if a filter between the rate indicator and engine deflection provided 180 degrees of phase shift at the bending frequency so the engine deflection would be opposite in sign to the indicated bending

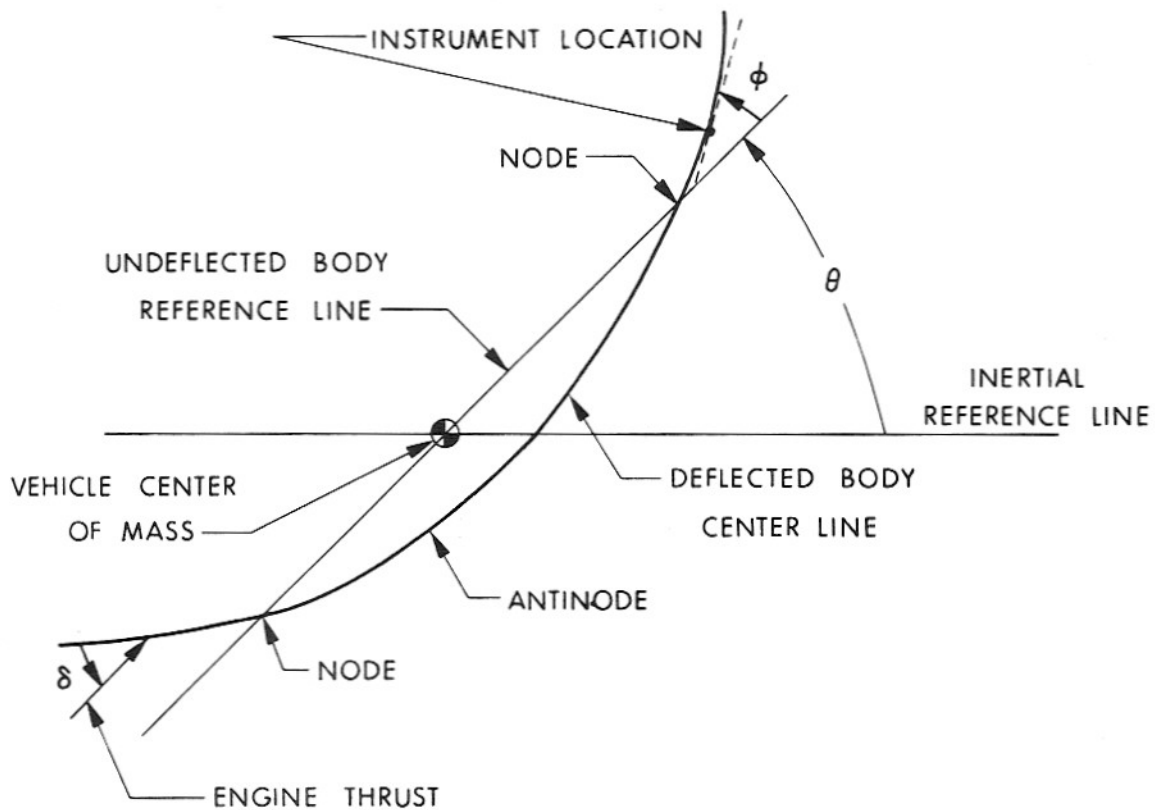

Fig. VII-1 Idealized Body Bending Mode Shape



rate. Notice that for the present purpose, it is immaterial whether the 180 degrees of phase shift at the bending frequency is phase lead or lag.

This qualitative view of the effect of the control system on body bending modes may be given quantitative significance using any of the standard methods of studying linear system stability. Consider the system configuration of Fig. VII-2 in which the vehicle is characterized by its rigid body dynamics and first bending mode. The indicated angle is compared with the commanded angle, and the compensated error signal commands the gimballed engine servo. The lead compensation which is necessary to stabilize even the rigid body dynamics may be thought of as realized either by rate gyro feedback or by an idealized lead network. For a bending mode shape such as that pictured in Fig. VII-1, a simplified root locus plot for this system has the general appearance of that shown in Fig. VII-3. A number of high frequency effects have been omitted from this figure to emphasize the basic problem of stabilizing the aerodynamically unstable vehicle which also suffers elastic deformations. The unstable character of the vehicle is indicated by the rigid body pole in the right half plane. A single pole corresponding to a first order lag approximation to the servo dynamics is shown, as is the zero due to the lead compensation. Were it not for the bending mode, this lead would clearly be adequate to stabilize the rigid body.

The lightly damped bending oscillation is indicated by the pole near the imaginary axis at the bending frequency. The parallel transfer of the rigid body angle plus the bending deformation angle to the attitude indicator gives rise to a zero near this pole. The indicated relation of the zero to the pole corresponds to the situation shown in Fig. VII-1. If it were possible to move the instrument location back along the vehicle, the zero would move toward the pole - lying on top of the pole and cancelling the effect of the mode in the control system when the attitude indicator is located at the antinode. In that location, the attitude indicator does not sense any angle due to the bending oscillation. If the attitude indicator were moved behind the antinode, the zero would appear below the pole in the upper half of the root locus plot and the small locus of closed loop root locations would lie to the left of the pole and zero. The first bending mode would be a stable oscillation for all control system loop gains in that case. However, higher frequency effects not shown in Fig. VII-3 would still be troublesome, so careful placement of the sensors is not generally adequate to solve the problem.

For the configuration shown in Fig. VII-3, which is commonly the case, the design problem results from the fact that for a loop gain high enough to stabilize the rigid body dynamics, which is indicated by the unstable closed loop pole crossing into the left half plane at A, the bending mode pole has already

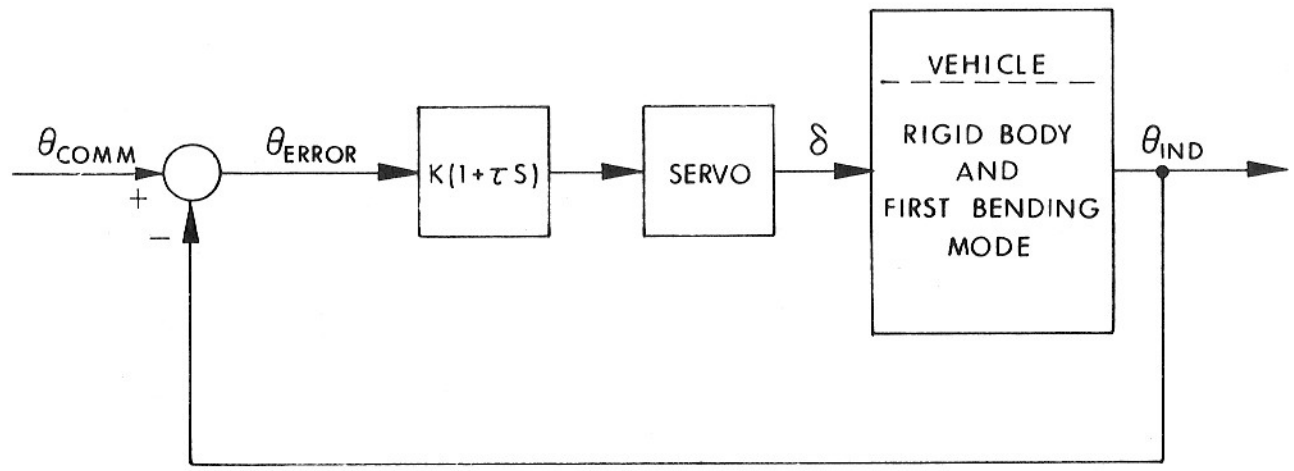

Fig. VII-2 Simplified Attitude Control System Configuration

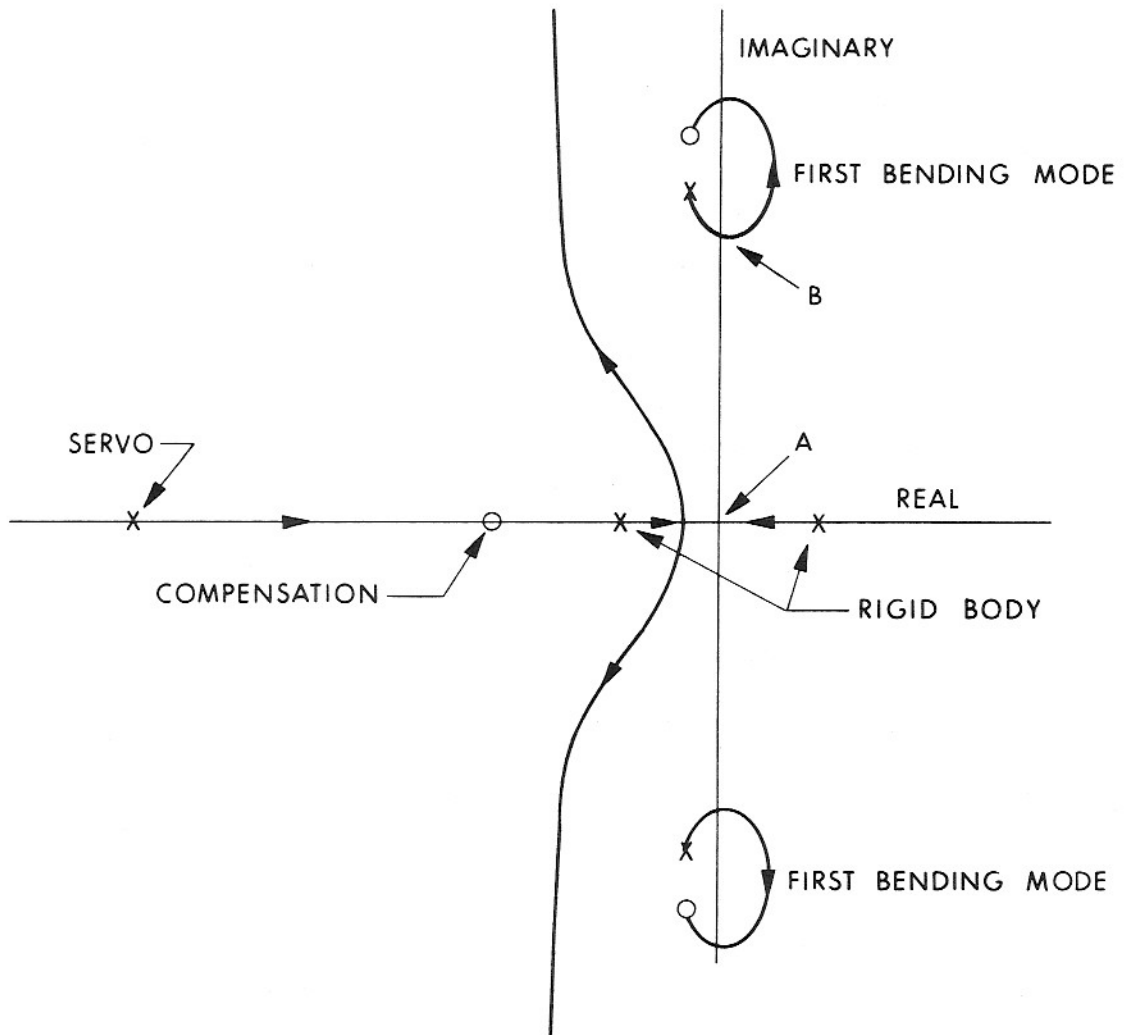

Fig. VII-3 Simplified Root Locus Plot for System with Rigid Body Compensation Only

crossed into the right half plane at B. Static stability demands a certain minimum loop gain as noted before, so it is essential to stabilize the bending mode at the required higher gain. This can be thought of as a requirement to turn the bending mode locus from the right to the left of the pole and zero. This can be accomplished by rotating the breakaway angle for the locus from the pole either clockwise or counterclockwise, which corresponds to either lag or lead compensation.

With lag compensation for the bending mode, the root locus has the appearance of that shown in Fig. VII-4. The additional lag has turned the bending mode locus to the left as desired, but it has adversely affected the dominant rigid body mode. There is, however, a range of loop gains for which the system is stable. It has a bandwidth well below the frequency of the bending mode. The neglect of any higher frequency effects may well be justified in this case.

With lead compensation for the bending mode, the root locus has the appearance of that shown in Fig. VII-5. The strong lead compensation required to turn the bending mode locus far enough has significantly influenced the locus of the rigid body mode. Considering only the dynamic effects shown in the figure, wide bandwidth operation would be possible. However, the additional lead maintains the open loop gain at higher frequencies and makes more high frequency effects important in the system. Higher ordered bending modes must then be included in the analysis. The lead at higher frequencies will not be as great, and there may well be instability indicated in a higher frequency mode.

In addition to all this, there is another source of dynamic modes to complicate the picture still further. For the liquid-fueled rockets under consideration here, the propellants are free to slosh back and forth in their tanks. This oscillatory change of momentum of the fluid particles reacts through the tank walls to affect the dynamic behavior of the vehicle - giving rise to additional lightly-damped modes. The analysis of these effects is facilitated by reference to a mechanical analogy to the sloshing fluid. The analogy can be taken in the form of a spring and mass with a degree of freedom normal to the body longitudinal axis, or a pendulum as shown in Fig. VII-6. The parameters of the mechanical analogies have been derived by a number of authors; among them is Lorell<sup>(1)</sup>. One such pendulum is required to simulate each mode of sloshing to be considered in each tank. For a multi-stage vehicle having two tanks in each stage, the complexity compounds rapidly. Fortunately it is often true that only the first sloshing modes in the largest tanks have frequencies in the pass band of the control system.

The coupling of the pendulum oscillation into indicated vehicle attitude is dynamic in this case as opposed to geometric in the case of body bending, so the effect is more difficult to visualize. However, the coupled equations of

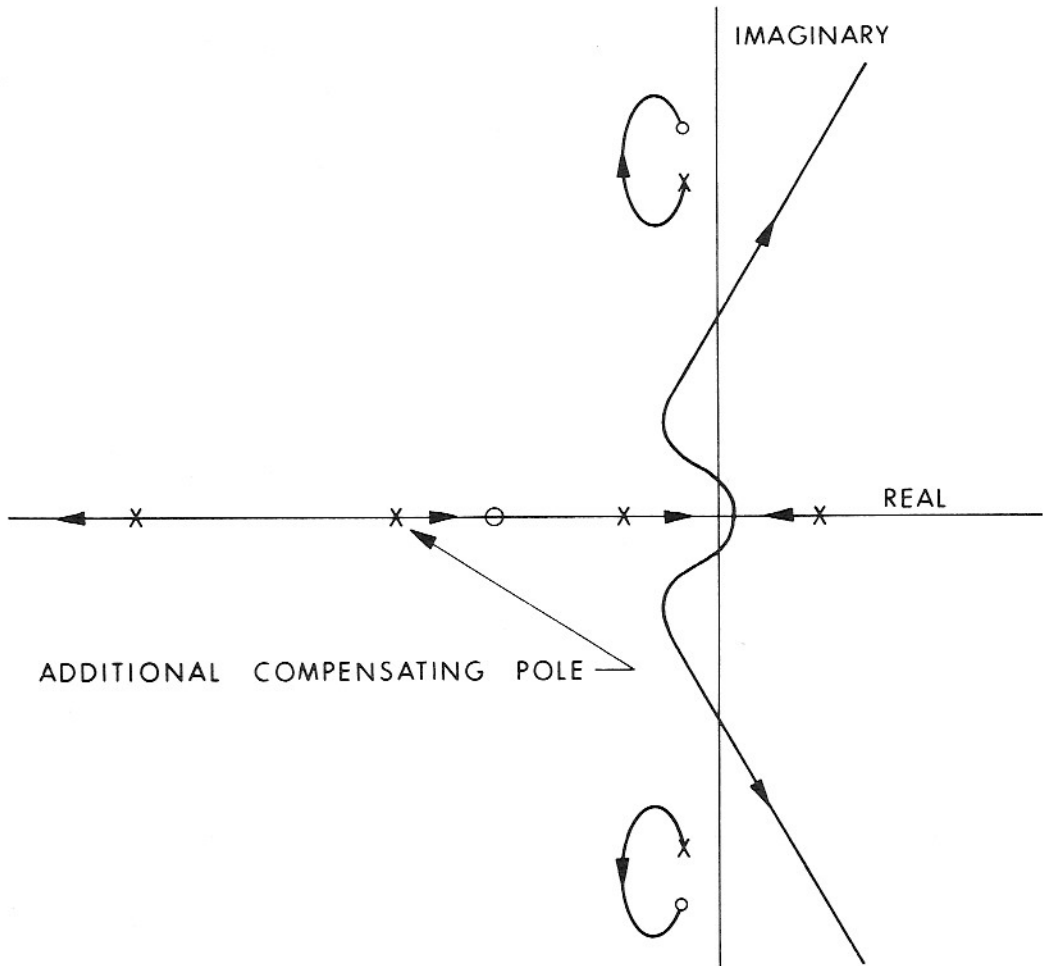

Fig. VII-4 Simplified Root Locus Plot for System with Lag Compensation for Bending Mode

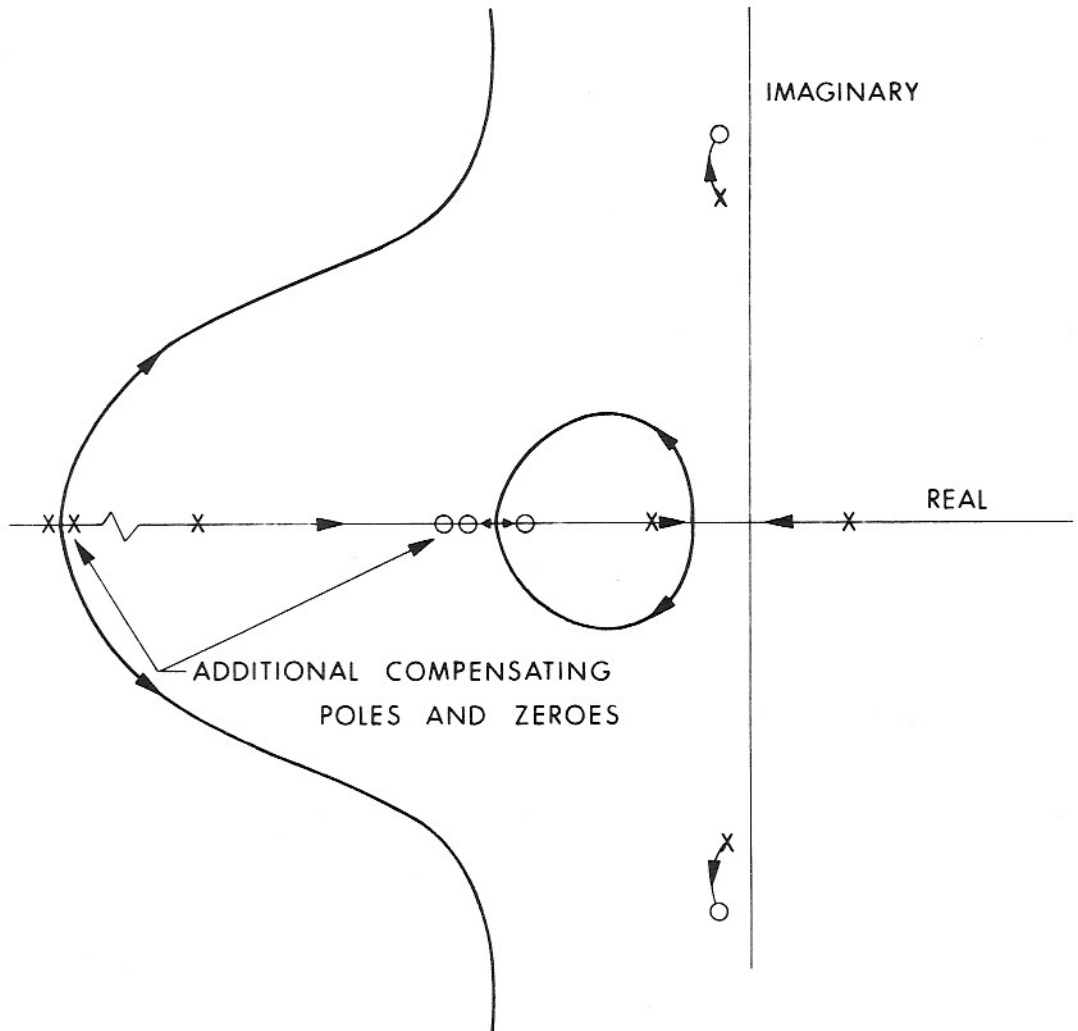

Fig. VII-5 Simplified Root Locus Plot for System with Lead Compensation for Bending Mode

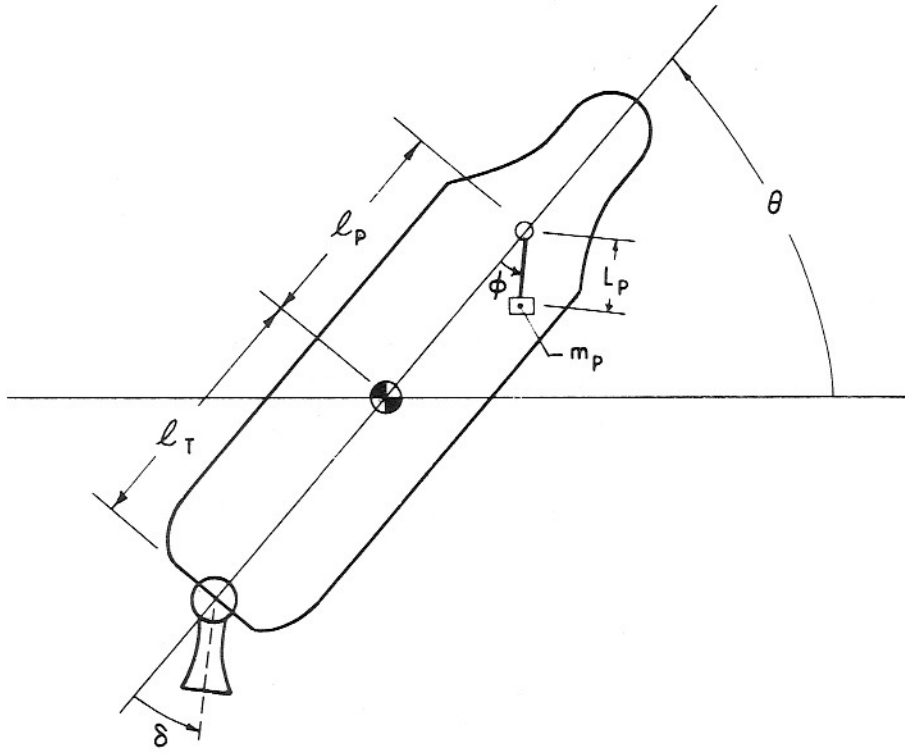

Fig. VII-6 Pendulum Analogy to Sloshing Propellant

motion for the vehicle and pendulum produce lightly-damped pole-zero pairs in the system open-loop transfer function just like those due to bending. A single tank located well forward of the vehicle center of mass or to the rear of the center of mass has its upper half plane zero located below the pole - the configuration which tends to give stable closed loop roots. There is an intermediate range of tank locations which puts the upper half plane zero above the pole and which would tend to give unstable closed loop roots unless compensated. These locations are characterized by the hinge point of the analogous pendulum lying in front of the rigid vehicle center of mass and the pendulum mass lying to the rear of the instantaneous center of vehicle rotation in response to control moments. This rotation center is forward of the rigid vehicle center of mass by the amount  $k^2 / l_T$ , where  $k$  is the rigid vehicle radius of gyration and  $l_T$  is shown in Fig. VII-6. There are two cases in which the zero lies on the pole and the slosh mode has no participation in vehicle dynamics: if the pendulum hinge is at the vehicle center of mass, in which case the pendulum reaction causes no moment about the vehicle center of mass, or if the pendulum mass is at the vehicle rotation center, in which case control moments do not excite pendulum motion. Having coupling between slosh modes and vehicle dynamics, the problem of compensation design is the same as for bending modes.

The controlled member is thus characterized by the unstable rigid body dynamics and an assortment of lightly damped oscillatory modes due to body bending and propellant sloshing. The design of compensation which at any one flight condition will either stabilize these modes or leave them essentially uncoupled is somewhat like juggling a large number of balls. Allowing any one mode to be badly behaved is like dropping just one ball - the act is a flop. And to make matters worse, the characteristics of these modes change continuously as the dynamic pressure varies and propellants are consumed. Compensation which works well at one flight condition may result in unstable operation at the flight condition which exists a half minute later. The least sensitive design is usually one which employs lag compensation and simply cuts off the control system bandwidth below the frequencies of the oscillatory modes. This leaves the bending and slosh modes essentially uncoupled from the control system. They are free to display their characteristic oscillations in response to whatever excitation they receive. For the lowest frequency bending and slosh modes particularly this may allow the existence of continuing oscillations which cause substantial structural loads. If so, the total system design is improved by using the control system to actively damp the lowest frequency modes. This requires a wider bandwidth control system. In fact, from just the point of view of structural loads there may well exist for any vehicle an optimum control system bandwidth: for lower bandwidths the loads due to poorly



damped oscillations tend to dominate and for higher bandwidths the loads due to control action tend to dominate. In the case of the propellant sloshing oscillation, a source of damping other than the active effect of the attitude control system is available and often used. At the cost of some weight, structural baffles may be built into the propellant tanks to break up the large-scale oscillations of the fluid near the free surface.

Fortunately, the requirements on the attitude control system, other than stability, are not very demanding in most instances. Very little bandwidth is required to follow the command inputs since the required attitude for efficient powered flights is usually very slowly changing. The requirement for speed of response to alleviate gust loads may be more demanding. In the selection of a system bandwidth to minimize structural loads, as discussed above, the effects of gust and wind shear inputs should be included. The requirement for efficient use of control action is not usually of crucial importance though there is some weight penalty associated with excessive demand for control moments. System simplicity and reliability is always an object of first importance. In the present context this requires the design of simple compensation using parameter values which can readily be realized, and finding simple ways to vary this compensation as needed during the flight.

Another basic choice which bears on the question of reliability is the choice of analog vs digital data processing to close the control loop. Wide band systems are usually more efficiently implemented with analog equipment, but the range of achievable bandwidths in this problem is not very large. On the other hand there is the need for variable compensation and loop gains and the desirability of complex zeros and poles in compensation functions, each of which can more readily be implemented by digital computation. Moreover, there is the fact, usually obscure at the outset, that after a system has been designed to serve its primary function it tends to grow to accommodate the additional requirements of the operational situation. One major cause of this growth is the need for a variety of modes of operation: check-out mode, primary mode, back-up mode, pilot control mode, etc. Mode switching requires changing connections in an analog system, and this increases the component count and decreases the reliability estimate. In a digital system, mode switching is accomplished by branching to another program stored in memory. Since fixed memory is highly reliable, this entails little penalty in the reliability estimate.

The design of a digital attitude control system is quite like the design of a continuous system with the additional requirement to choose the sampling period and quantization of computer input and output variables. The sampling

period is chosen primarily on the basis of the desired system bandwidth. If, for example, it is decided that the first bending mode is to be stabilized and higher frequency modes isolated as much as possible, the sampling frequency would be chosen perhaps five times greater than the first bending frequency. If the form of the attitude indicator and A/D convertor permits it, insertion of a low-pass filter before the sampler would be wise in most cases to attenuate the higher frequency noise which might be modulated down into the control system pass band by the sampling process. The signal quantization levels are chosen to cause no more than some tolerable degree of graininess in the operation of the system.

An example of a digital attitude control system for a large vehicle may be cited from the Apollo program. The configuration of the vehicle as it decelerates from the translunar trajectory into the lunar circular orbit is shown in Fig. VII-7. The Lunar Excursion Module is shown attached to the Command Module in the position that allows the astronauts to move from one vehicle to the other. This configuration is rather flexible, most of the bending occurring in the coupling structure between the vehicles. The frequency of the first bending mode is about 2 cps. Fuel sloshing has little effect on the dynamics of this vehicle, the mass of fuel which participates in the sloshing oscillation being only a very small fraction of the mass of the vehicle. The analytic manifestation of this small mass ratio is the very close proximity of the zero to the pole in the sloshing pole-zero pair. Thus the zero nearly cancels the pole and both can be ignored in the analysis of this system. The attitude control system uses a sampling frequency of 25 cps and employs angle information only; no rate gyros are required. The attitude information which is the input to the digital Apollo Guidance Computer (AGC) is quantized at 40 arc sec. The output of the AGC is the command to the engine gimbal servo which is held between the sampling points; this command is quantized at 160 arc sec.

A Z plane locus of roots for the sampled system without compensation is shown in Fig. VII-8. The rigid body dynamics in the absence of atmosphere are just due to the vehicle inertia; this gives rise to the two poles at +1. Pole-zero pairs due to the first two bending modes are included. Without compensation, the first bending mode goes unstable immediately for very low system gain. The locus with lag compensation is shown in Fig. VII-9. In this case a single compensating zero has been used which corresponds to the rigid body compensation mentioned earlier, plus four poles to attenuate higher frequencies sharply. The closed-loop root locus originating at the first bending pole is seen to be pulled well into the stable region. The corresponding locus with lead compensation is

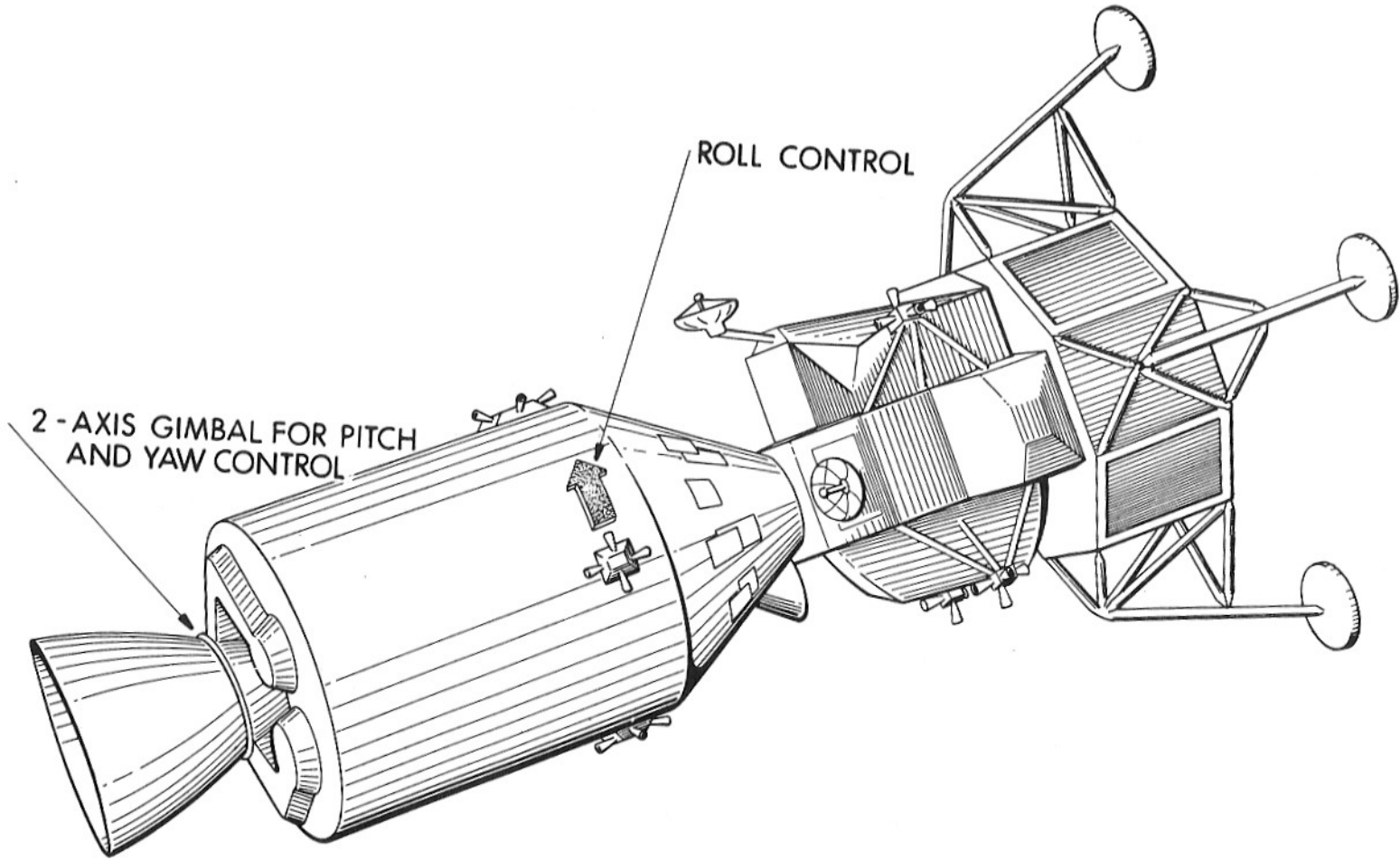

Fig. VII-7 Apollo Lunar Approach Configuration

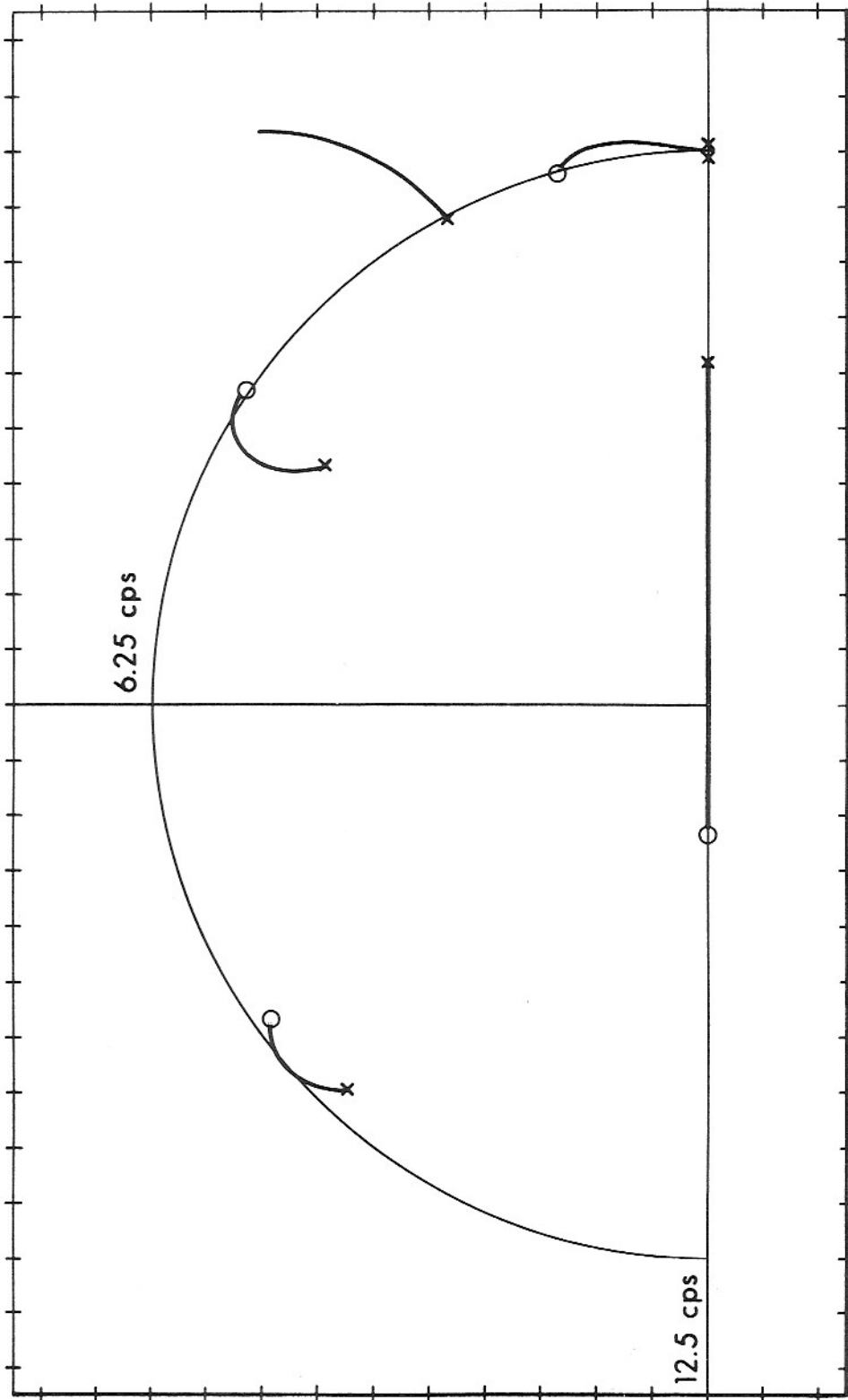

Fig. VII-8 Z Plane Locus of Roots: without Compensation

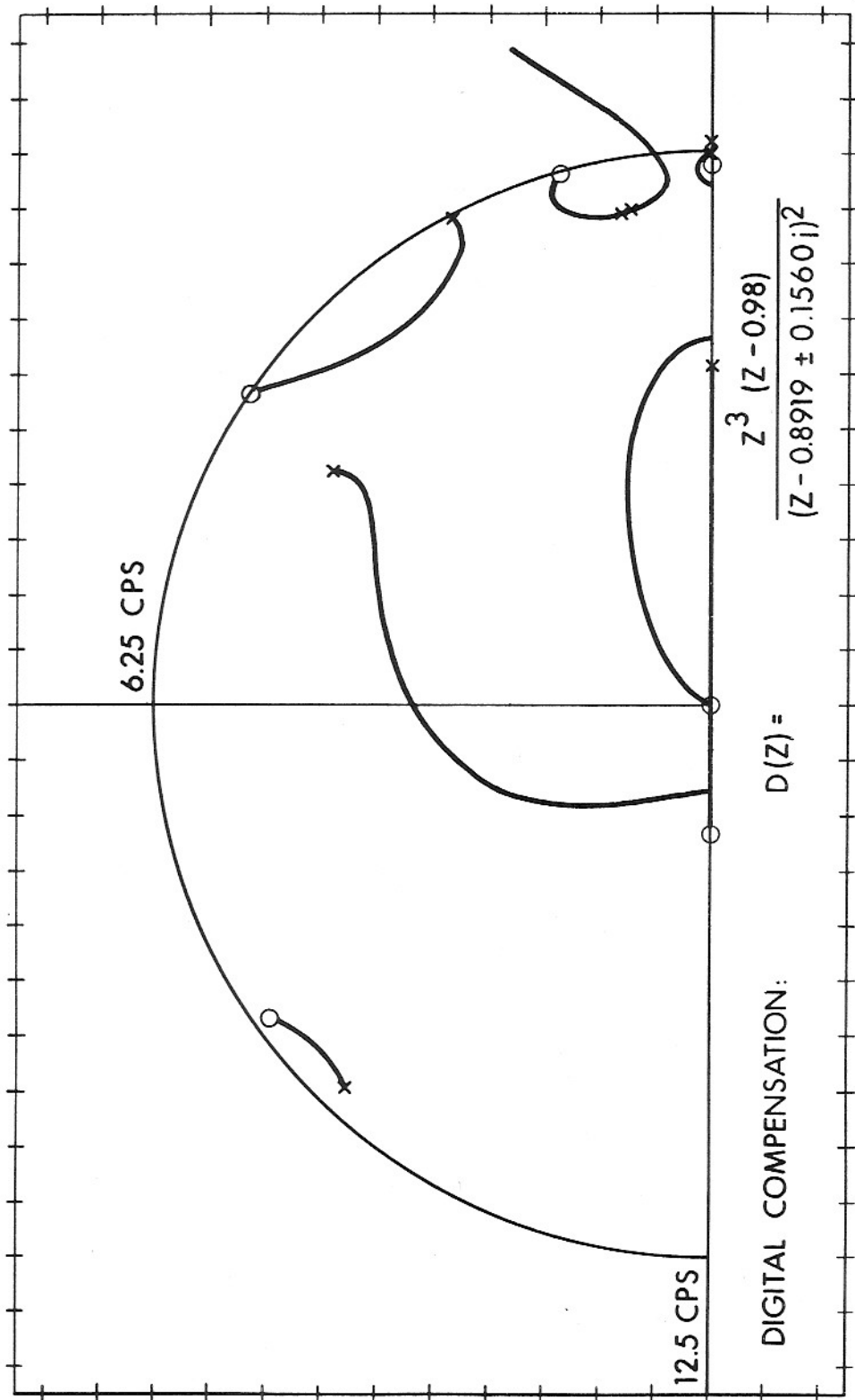

Fig. VII-9 Z Plane Locus of Roots: with Lag Compensation

shown in Fig. VII-10. In order to provide active damping of the first bending mode, considerable lead was required. As can be seen in the figure, compensation involving five zeros and five poles is employed for this purpose. The result shows the first bending mode to be not only stabilized but rather well damped. With each of these forms of compensation, the dominant system closed-loop poles have a natural frequency of about 1 rad/sec, roughly one-tenth the fundamental bending frequency. With lead compensation, however, there are closed-loop zeros in the vicinity of these poles resulting in a significantly shorter response time to transient inputs. The bandwidth of each system as measured by the frequency at which the magnitude of the open-loop transfer function is unity is nearly the same - about 1 rad/sec - but the lag compensated system has more phase lag at this frequency and cuts off much more sharply for higher frequencies.

The step response of this system with lead compensation is shown in Fig. VII-11. This response was recorded by a simulator which used an analog computer to simulate the vehicle dynamics but used an actual AGC as the controller. The basic system response is seen to follow quite well the transient response characteristics corresponding to the dominant poles in the Z plane. Moreover, the bending oscillation is seen to be reasonably well damped. An interesting problem is pointed up by the occasional bursts of activity after the major response transient is over. These are occasioned by the attitude error drifting far enough to cause an indicated 1 quantum of error. This is a small error and the actual error rate is very small, so very little control is required to return the error to the zero quantum zone. However, the computer has seen an indicated zero error for many sampling periods, so when one quantum of error is indicated the lead compensator interprets this change as a significant rate of change of error, with a similar interpretation of higher derivatives. This touches off an unnecessarily long period of control activity during which the bending modes are again excited.

So the problem of the attitude control of large, flexible space vehicles is indeed challenging - and it will become even more so in the future. As the vehicles get larger the bending and slosh frequencies become lower, but the performance required of the system does not necessarily decrease. Thus the requirement will be to push the system performance in terms of bandwidth closer to and beyond the bending and slosh frequencies. This can be done, but it makes the stability of the system critically dependent upon the detailed characteristics of these modes - and these characteristics are not altogether predictable in advance of the flight. Thus the interest in self-adaptive control

systems for this application. It may also be that modern estimation theory will find some application to this problem. In the meantime, classical linear system analysis techniques remain very useful tools for the system designer, but the complicated character of the controlled member makes hand application of these techniques impractical. A powerful attack on the problem can be launched by preparing a series of digital computer programs to do the tasks that one would otherwise do by hand: tasks such as plotting the frequency response function for an open or closed loop system given the cascade of elements which comprise the open loop system, calculation of the sampled transfer function given the continuous transfer function, plotting the locus of closed loop roots for a sampled or continuous system given the open loop transfer function, etc. Programs\* such as these have been used to carry out the design of the Apollo systems at the MIT Instrumentation Laboratory. It is difficult to see how the job could have been done on a reasonable schedule without automation of these analytic operations.

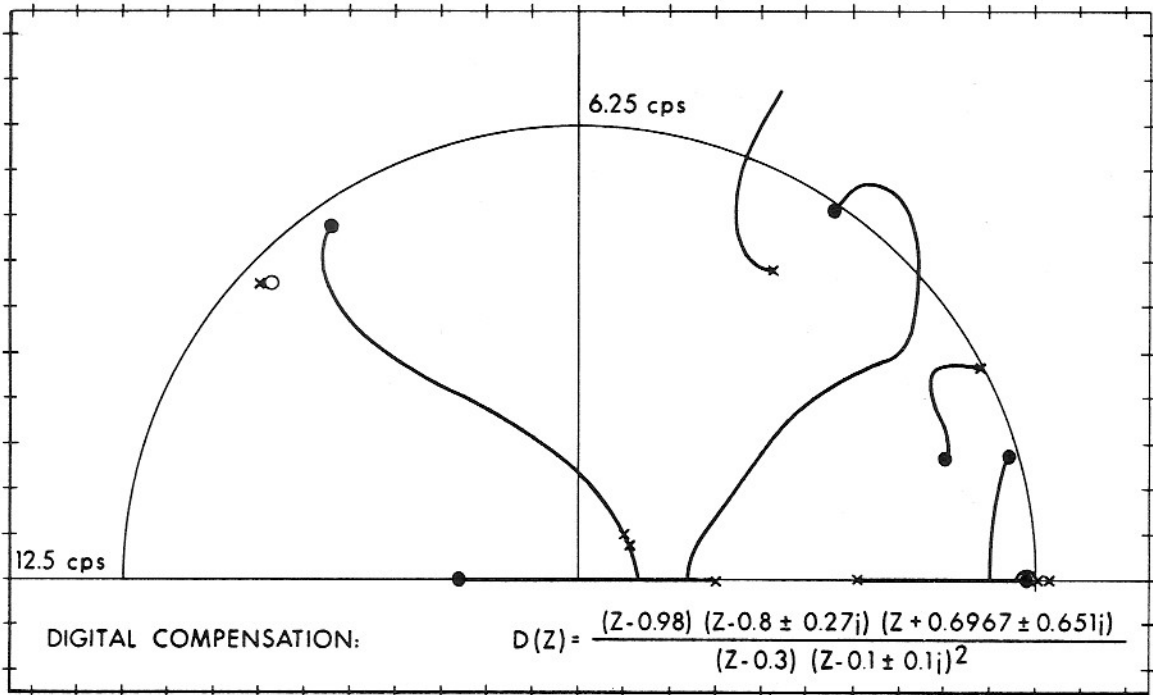

Fig. VII-10 Z Plane Locus of Roots: With Lead Compensation

\* Prepared primarily by Donald C. Fraser.

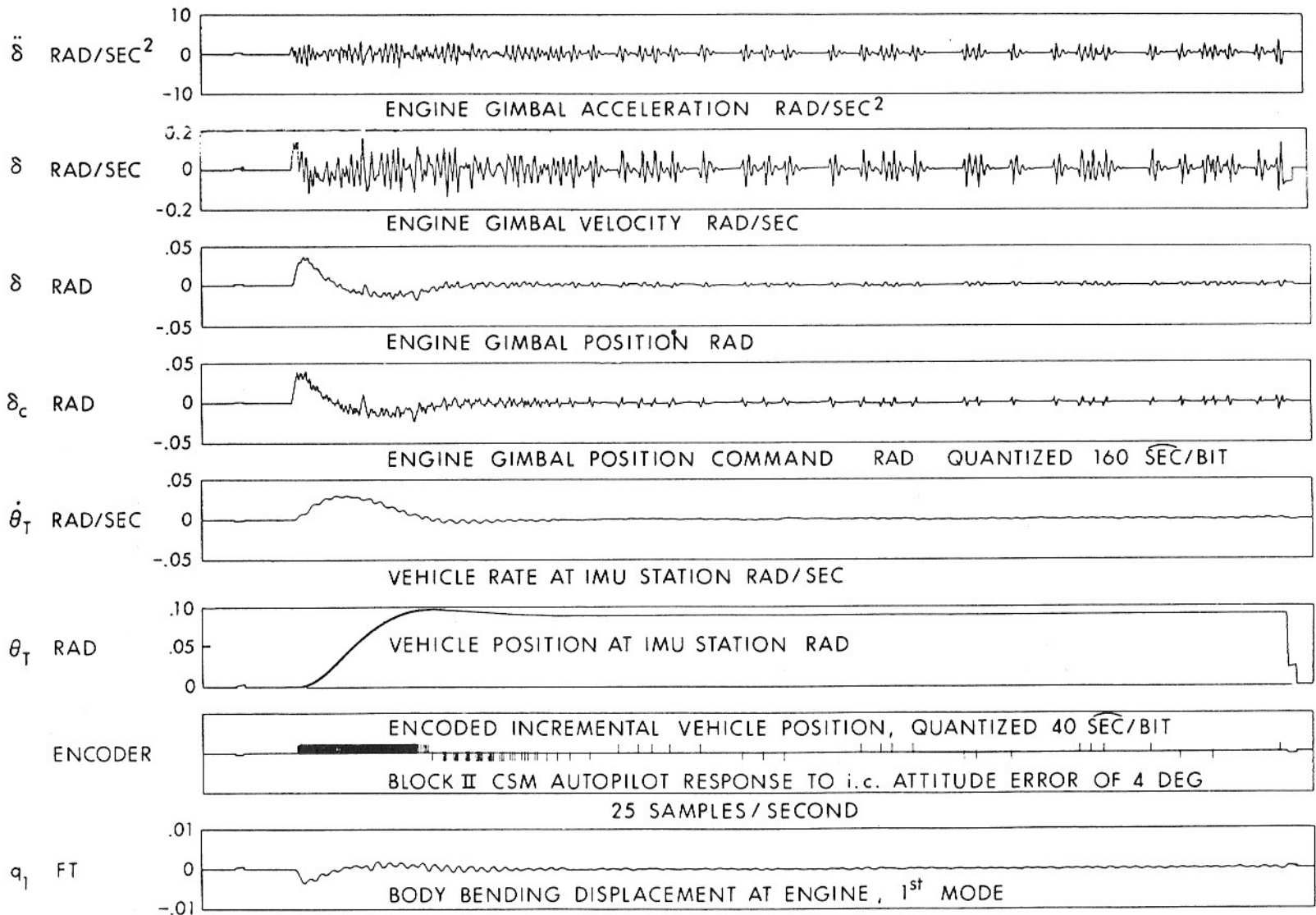

Fig. VII-11 Step Response of Attitude Control System



## ATTITUDE CONTROL WITH A FIXED ENGINE

The possible elimination of the massive engine gimbal structure and associated high-power actuators and servo systems is a very appealing step in the direction of system simplicity. The alternative is a control system based on on-off switching of attitude control reaction jets. The control thrusters must in this case be capable of delivering substantial control torque to balance the possible range of thrust axis offsets for the main engine. This offset is due to a number of causes. There is some tolerance in the mounting and aligning of the engine. The thrust axis does not lie along the engine centerline due to unsymmetrical flow and unsymmetrical nozzle ablation. But the major cause is the uncertain location of the vehicle center of mass. During any one mission phase the center of mass may move appreciably as propellants are consumed from off-axis tanks. An interesting compromise design is one which has the main engine gimballed but provided only with a low-power actuator and very simple servo, such as a constant rate drive, which is switched in sign so the thrust axis tracks the vehicle center of mass. This will permit the use of smaller thrusters for attitude control.

For the present, consider the design of an attitude control system for a vehicle with a fixed engine. This configuration would not be attractive for the control of a very large, high-thrust booster in atmosphere. For a smaller vehicle out of atmosphere the vehicle dynamics are essentially just the inertia effects, body bending and propellant sloshing being very high frequency modes. The parameters which dictate the design in the absence of thrust axis offset are the vehicle acceleration due to control moment, the minimum on time for the control thrusters, and the maximum allowable attitude error. In this situation, with the control moment designed to accommodate the maximum possible thrust axis offset, the acceleration due to control moment is likely to be very large. Also, for any thrusting system, there is a minimum on time which can reliably be commanded. The product of this control acceleration and minimum on time then gives the minimum change of vehicle angular velocity which can be commanded; call it  $\Delta \dot{\theta}_{\min}$ . The most favorable symmetric limit cycle which can be achieved in the absence of thrust offset consists of a coast at the rate of  $1/2 \Delta \dot{\theta}_{\min}$  to the specified error boundary,  $\theta_{\max}$ , a minimum control impulse at that point which changes the vehicle rate to  $-1/2 \Delta \dot{\theta}_{\min}$ , and a coast to the negative  $\theta_{\max}$  boundary. This limit cycle is shown in the phase plane in Fig. VII-12. The angle at which the control moment is switched on and off is

$$\text{Switching angle} = \pm (\theta_{\max} - 1/8 \alpha_c t_{\min}^2) \quad (\text{VII-1})$$

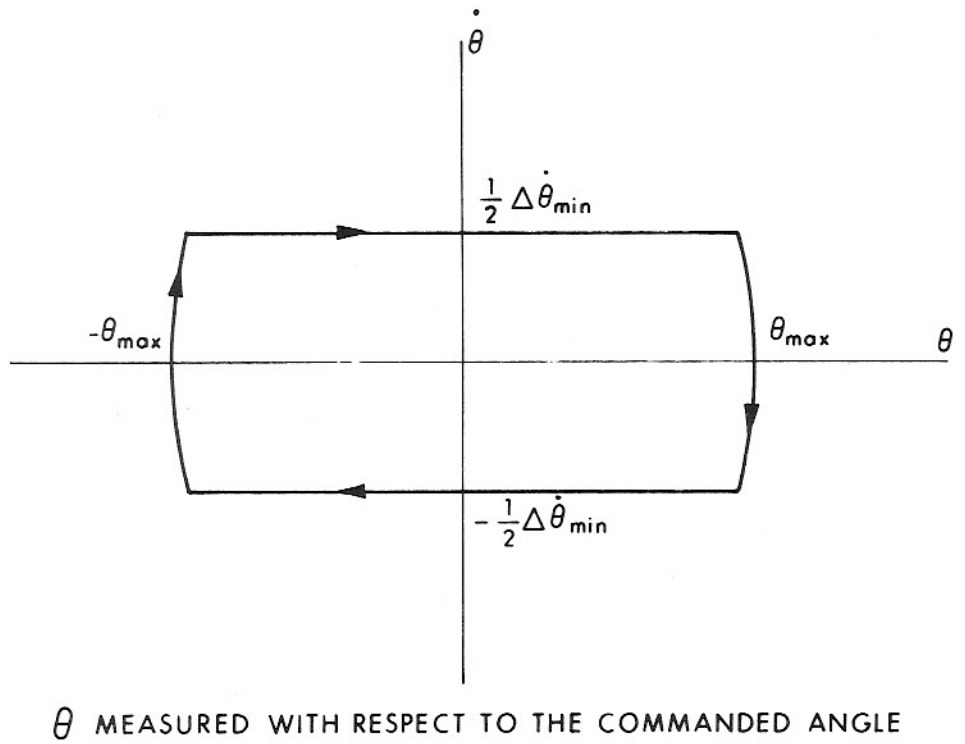

Fig. VII-12 Minimum Symmetric Limit Cycle with no Thrust Offset

where  $\alpha_c$  is the angular acceleration due to the control moment. The thruster duty cycle is

$$\text{Duty cycle} = \frac{2}{\frac{8 \theta_{\max}}{\alpha_c t_{\min}^2} - 1} \quad (\text{VII-2})$$

If, for example, the maximum allowable error is 1 deg, the angular acceleration due to control is 10 deg/sec<sup>2</sup>, and the minimum control on time is 10 milliseconds, the switching angle is 0.9999 deg and the duty cycle is  $2.5 \cdot 10^{-4}$ . With this large a control acceleration, the limit cycle looks rectangular on the phase plane. The thruster duty cycle is quite favorable -- the thrusters being on only 0.025 percent of the time. The vehicle coasts for 40 sec, thrusts for 10 millisecc, and coasts for 40 sec again. This is of course an idealization which assumes constant input, perfect information, and no disturbances. The same performance would result with a constant rate input.

This limit cycle can be achieved in the absence of thrust offset using standard switching logic. Figure VII-13 shows a common system configuration in which a linear combination of error and error rate controls the thrusters through a trigger circuit or switching logic which includes a dead band and hysteresis. The indicated derivative can be thought of either as an idealization of a lead network or the effect of rate gyro feedback. Given the magnitude of the control torque, this system is designed by choosing values for the free parameters  $k$ ,  $\delta_1$ , and  $\delta_2$ . The switching logic is assumed symmetrical. Realization of the limit cycle shown in Fig. VII-12 places two constraints on these free parameters; the two switching lines on each side of the origin must pass through the corners of the desired phase trajectory. There remains a degree of freedom yet to be specified. This freedom can be used to achieve fast recovery from step changes in command of probable magnitude. If  $k$  is very small, and  $\delta_1$  and  $\delta_2$  are chosen to yield the desired steady-state limit cycle, the response to a change in command is poorly damped. Such a phase trajectory is shown in Fig. VII-14. If  $k$  is very large, and again  $\delta_1$  and  $\delta_2$  are chosen to yield the desired steady state limit cycle, the response to a change in command is slow and sluggish as indicated in Fig. VII-15. For any given initial error there is a choice of  $k$  (and  $\delta_1$ ,  $\delta_2$ ) which will carry the response into the limit cycle immediately as indicated in Fig. VII-16. The magnitudes of command changes are not predictable, of course, but some are more likely than others -- and  $k$  (and  $\delta_1$ ,  $\delta_2$ ) can be chosen to yield good response in the most probable cases.

Having such a system designed to yield good step response for inputs of likely magnitude, and an efficient limit cycle, it remains to be seen how the performance changes with thrust offset. The performance can be quite adversely

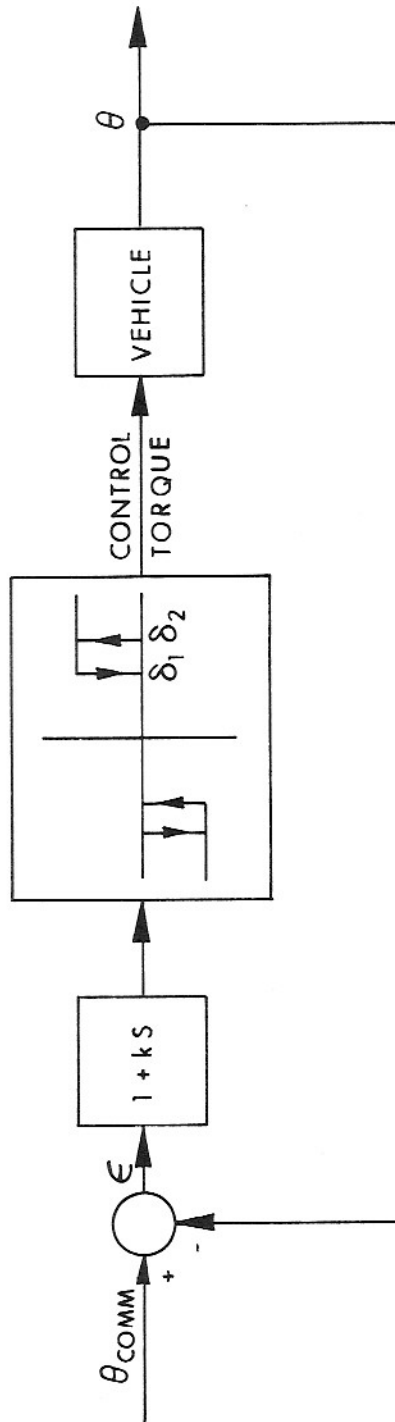

Fig. VII-13 Standard On-Off Control System

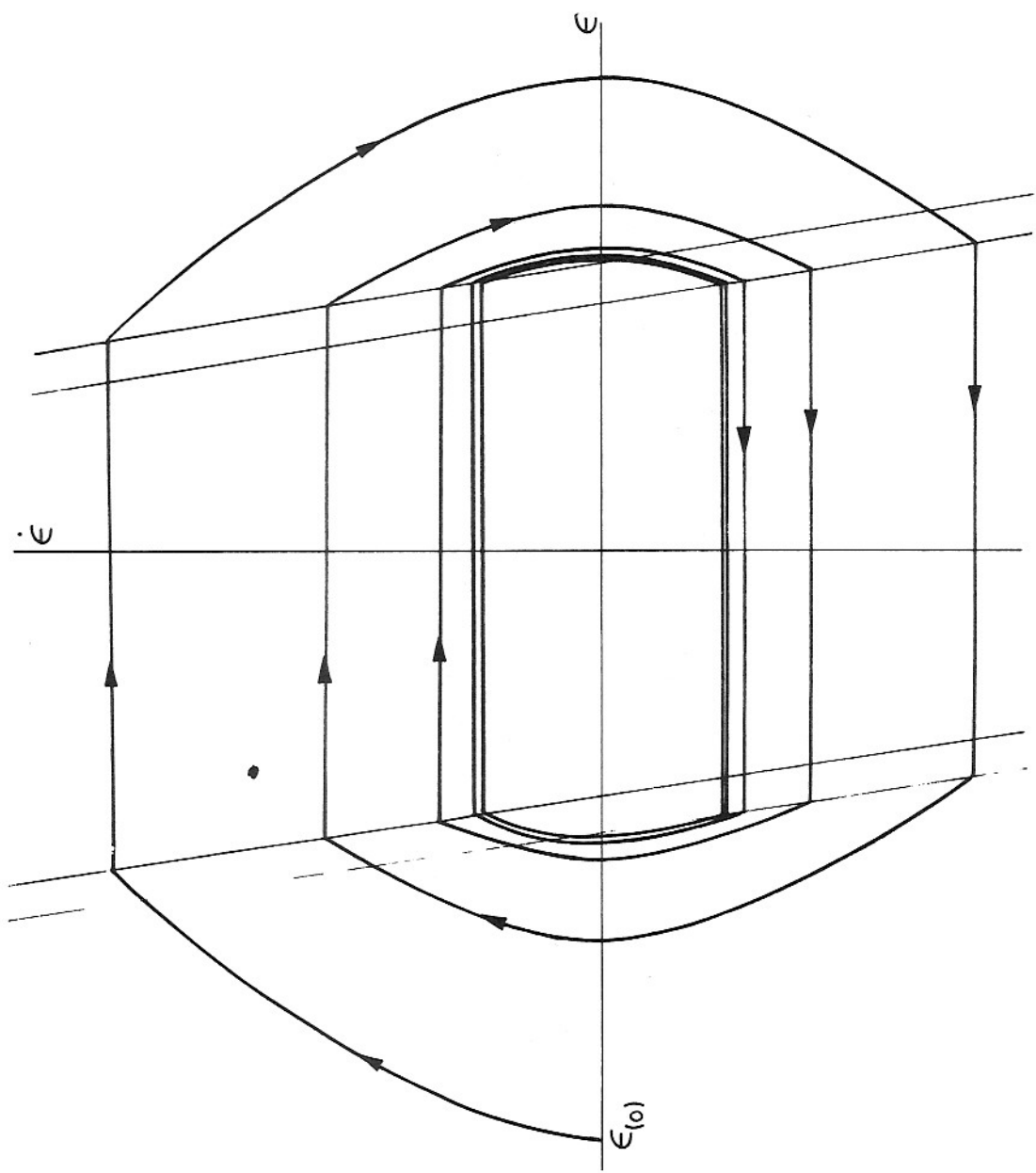

Fig. VII-14 Step Response with Small Rate Gain

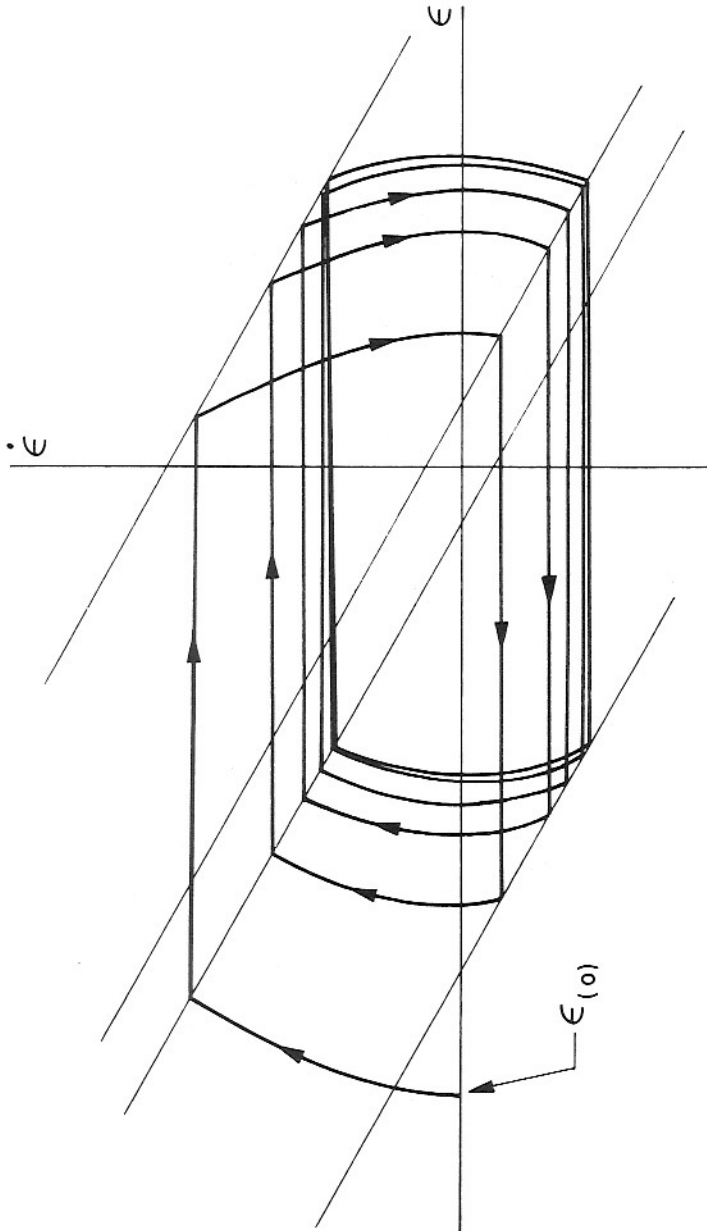

Fig. VII-15 Step Response with Large Rate Gain

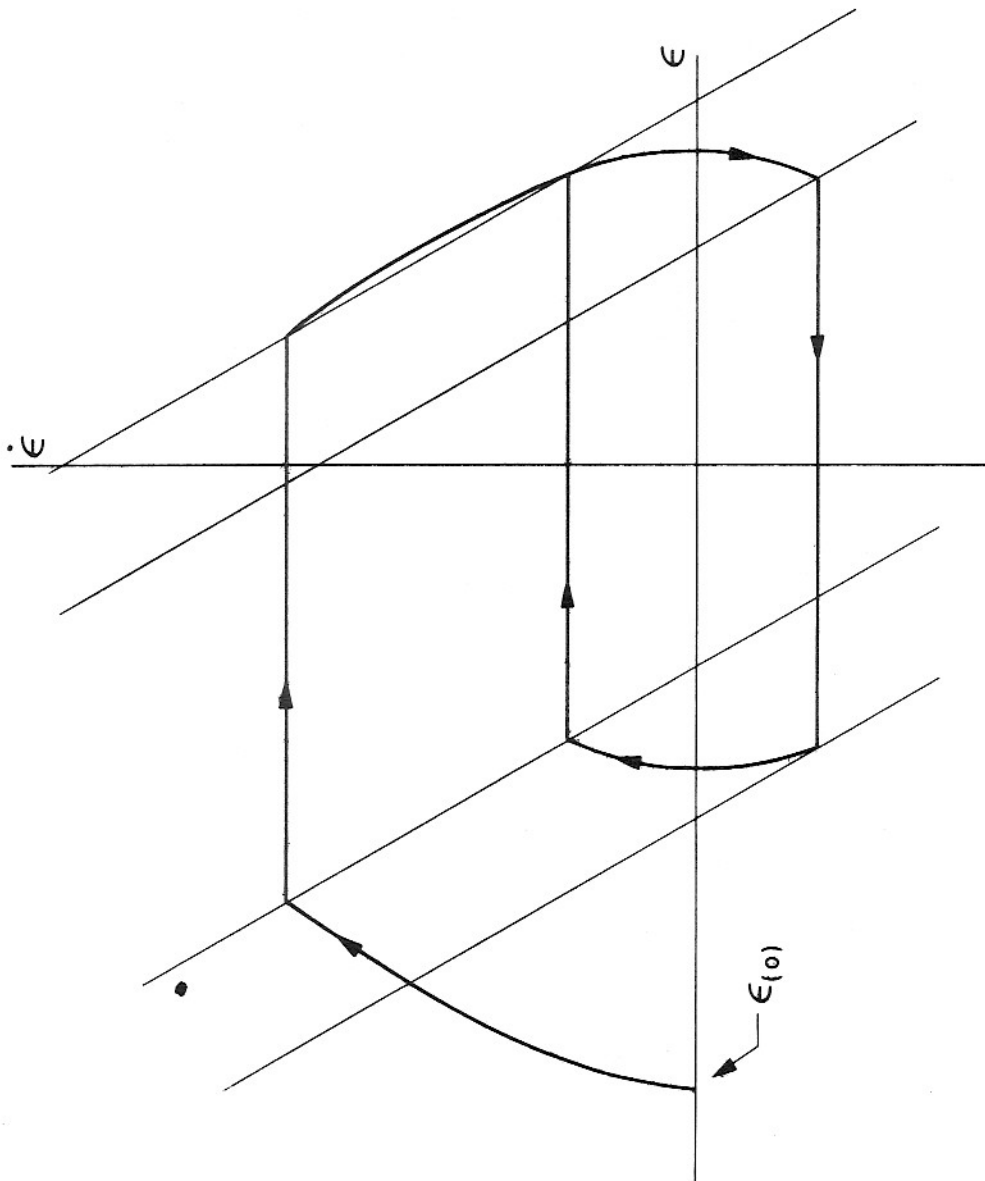

Fig. VII-16 Step Response with Proper Rate Gain

affected as suggested by Fig. VII-17. This figure shows one form of limit cycle which may result from a positive offset moment -- which tends to drive the error rate negative. The trajectory is shown starting from the switching line in the first quadrant. A minimum positive control impulse is commanded at that point, which acting with the offset torque drives the vehicle to a large negative rate. The negative acceleration then continues due to the offset torque alone until the trajectory hits the lower switching line. From that point the phase trajectory "chatters" between the switching lines moving to the left and approaching a limiting closed cycle. This steady-state operation is undesirable both because of the negative error bias and because of the rapid on-off cycling of the thrusters which is wasteful of fuel.

If the amount of the thrust offset were known, it would be easy to command a much more desirable limit cycle. The thrusters would never be used to add to the offset torque unless the offset were below some threshold. Rather, one portion of the cycle as seen in the phase plane would be the parabola due to the offset moment alone which just stays within the specified error bound. The other portion would be the parabola due to the control moment acting against the offset moment and which also stays just within the specified error bound. Such a trajectory is shown in Fig. VII-18. With the vehicle dynamics modeled as just an inertia, the required conditions for switching the control moment on and off are easily and simply expressed. The remaining requirement is an indication of the offset moment in addition to the error and error rate. It is clear that information about the offset moment is contained in the time history of attitude which results from the known history of control moment. If, for example, one took an estimate of the offset moment and applied it together with the known control moment to a model of the vehicle dynamics, and later found that the attitude indicated by the model tended to grow more positive than the attitude of the actual vehicle, this would be evidence that the estimated offset moment was in error in the positive sense. This information could then be fed back to adjust the estimated offset moment.

This is the physical concept which underlies optimal linear estimation theory as formalized primarily by Kalman<sup>(2)</sup>. The form of the Kalman estimating filter is shown in Fig. VII-19 where only one quantity is shown as being measured and several parameters may be estimated. It is also possible to process more than one measurement at a time. A model of the system is used to generate a prediction of the quantity being measured based on the current estimates of all parameters being estimated. The difference between the predicted measurement and the actual measurement feeds back through gains to alter the parameter estimates. A gain computer varies the estimate adjustment gains in an optimal manner depending on the nature of the measurement and the statistics of the measurement errors and of the uncertainties in the prior knowledge of the estimated quantities. In the present application, the



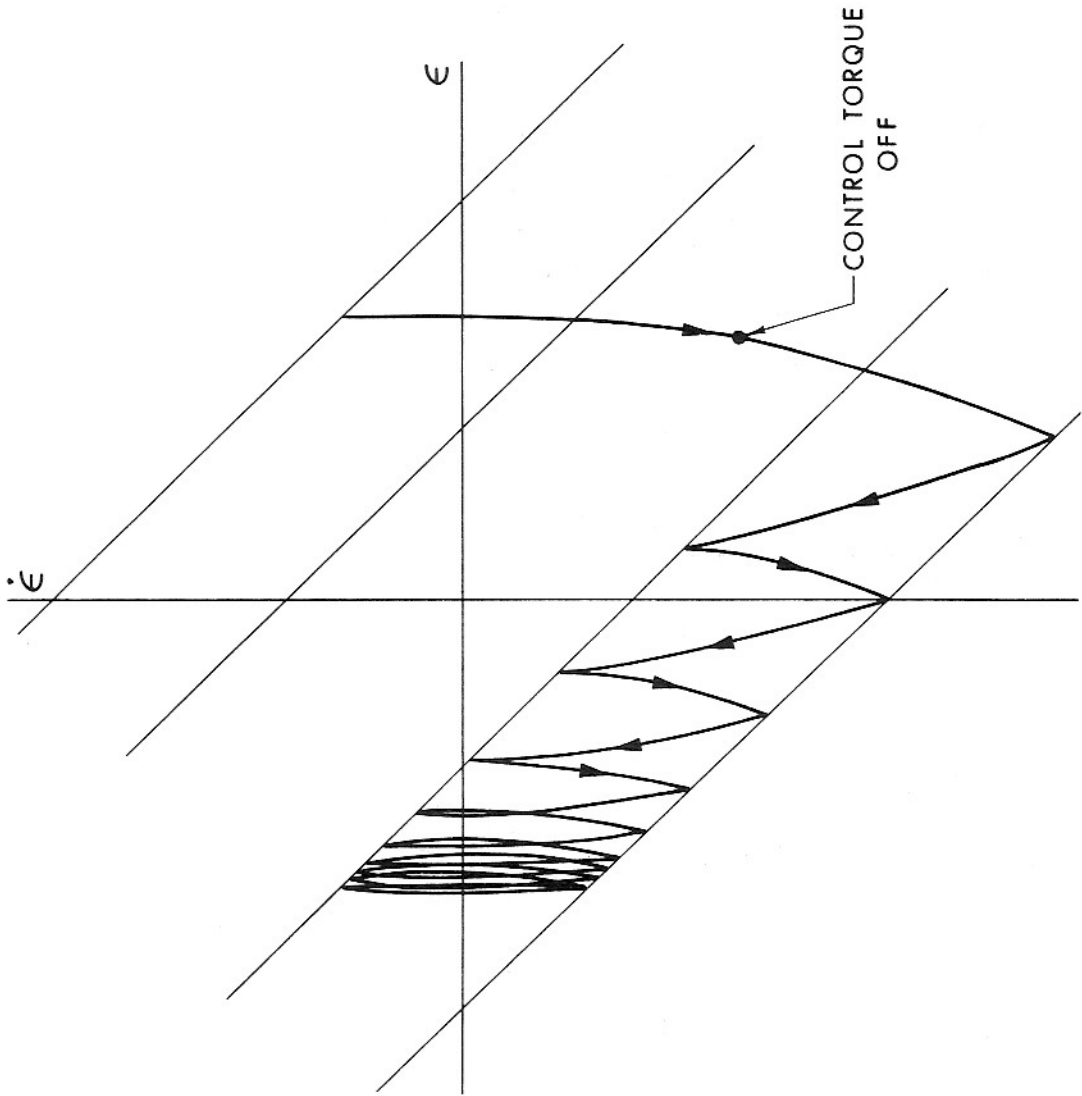

Fig. VII-17 Limit Cycle with Thrust Offset

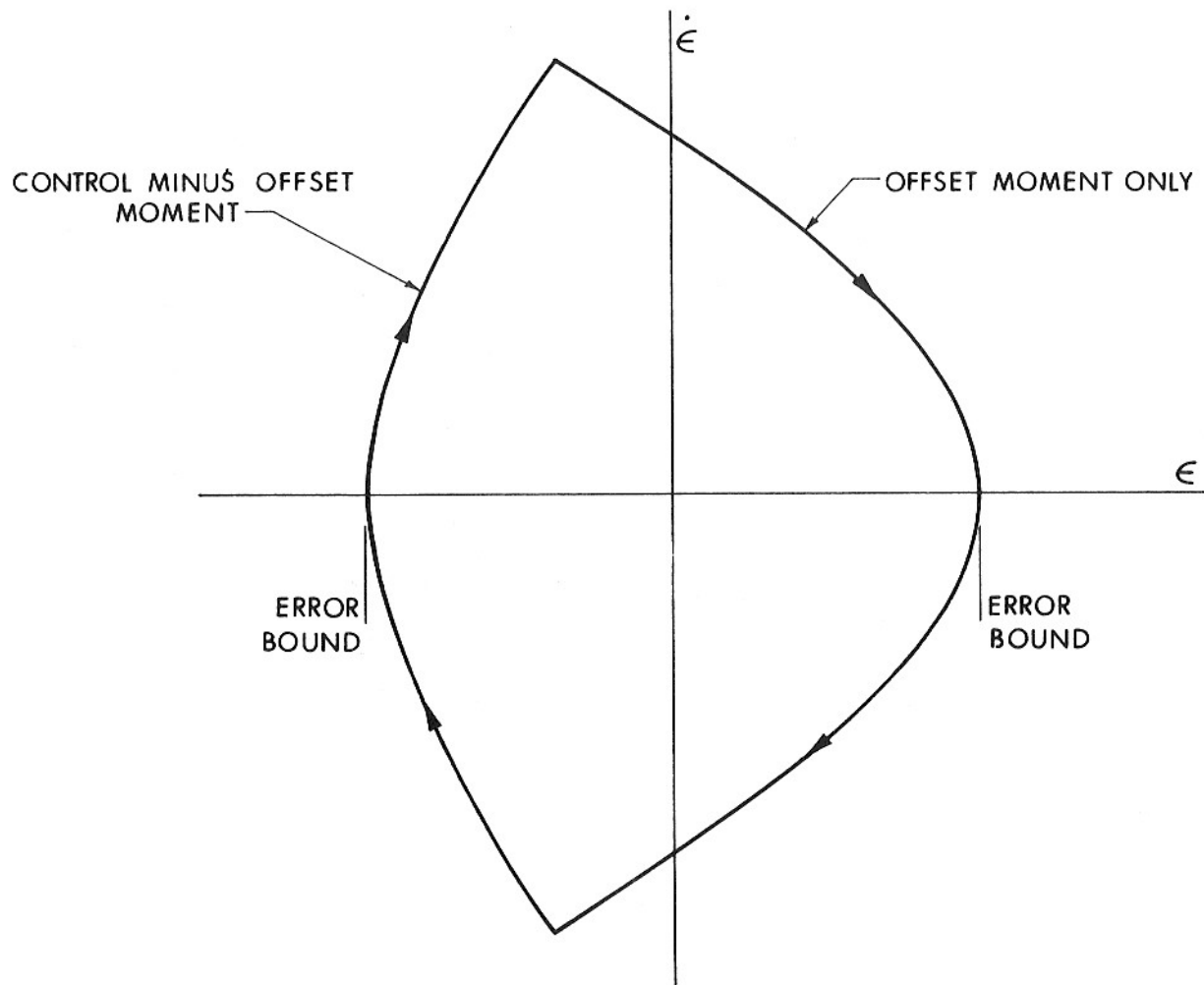

Fig. VII-18 Desirable Limit Cycle with Thrust Offset

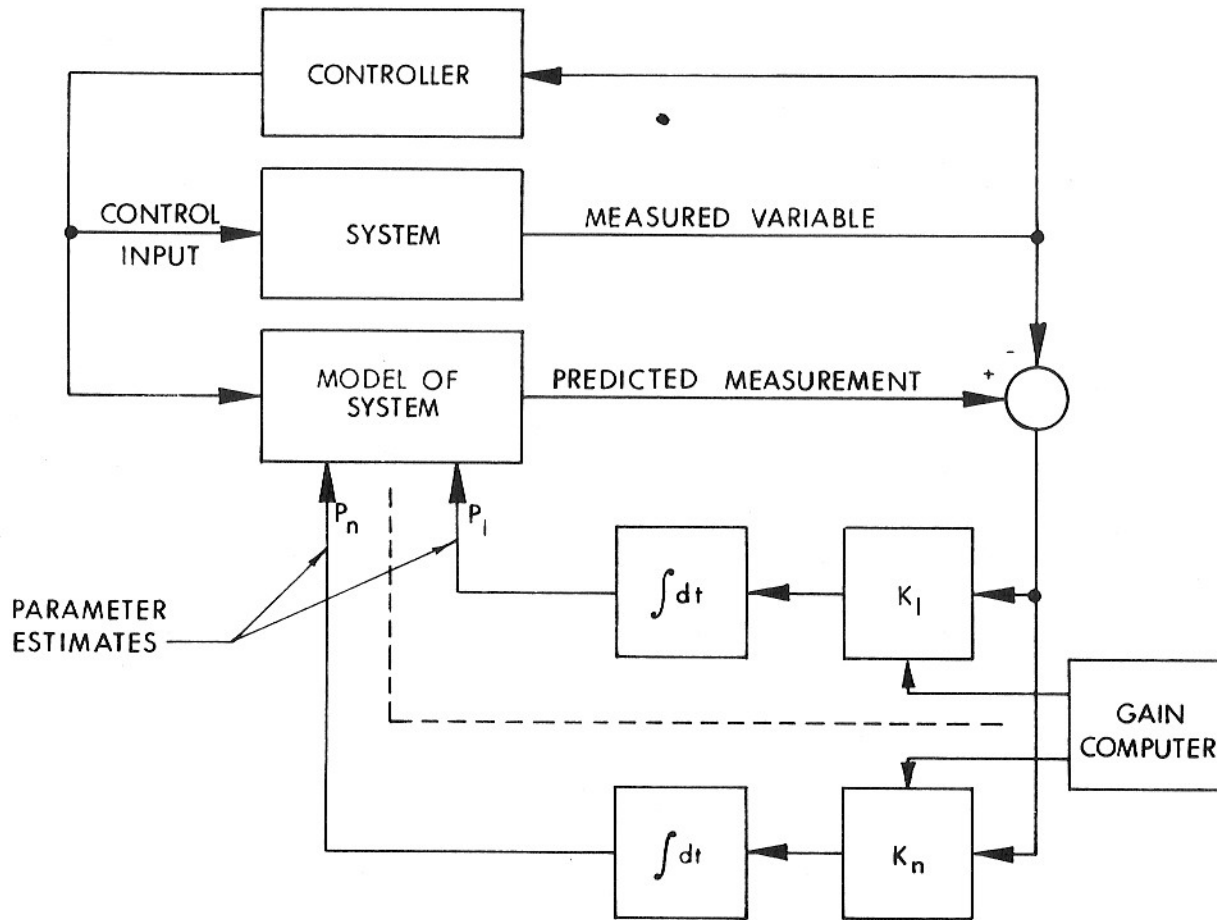

Fig. VII-19 Form of the Kalman Estimator

measured quantity is vehicle attitude and the estimated parameters would include vehicle attitude, attitude rate, offset moment, and possibly vehicle inertia. Vehicle attitude is included as an estimated parameter even though it is the measured variable since the measurement is subject to noise or uncertainties. With an appropriate model of the system being of such simple form in this case, the major computational load is the gain computation. But the optimally varying gains converge quickly to steady-state values, and in many mission situations, little would be lost by using constant gains. If that is the case, then estimates of all the quantities needed to permit efficient control with arbitrary thrust offsets can be generated with very little required computation.

The resulting system can of course be instrumented with either analog or digital computation. Because of the rapid response of the vehicle to control and offset moments, rather high sampling frequencies would be required if a digital computer were used in the standard way in which control action can be taken only when the computer samples the attitude and processes the control equations. For example, in a limit cycle of the form of that shown in Fig. VII-18 corresponding to a control acceleration of  $50 \text{ deg/sec}^2$ , an offset acceleration of  $10 \text{ deg/sec}^2$ , and an error tolerance of 0.5 deg, the control torque is on for a period of 0.2 sec each cycle. If this time is to be resolved with no more than 10% error by the basic computer samples, a sampling frequency of 50 samples/sec would be required. This could impose an appreciable load on the computer. However, if the computer is organized (as is the Apollo Guidance Computer) to count input pulses while processing other calculations, and also can be interrupted briefly when a certain count has been reached to issue a discrete output, then control action can be taken at times other than the basic computer sampling times. With this capability, a slower sampling frequency can be used. Each time the attitude is sampled and the estimates of parameters updated, the computation can predict whether control action (either on or off) should be taken before the next sampling point. If so, the time till that event or the change in attitude till that event can be read into a counter and counted down. Each time a thruster is turned on, the time it should be on is calculated and read into a counter so it can be turned off again between sampling times.

A fixed-position rocket engine is used in the ascent stage of the LEM. For the purpose of standardization, the same hypergolic thrusting system used on the Command and Service Module is also used on the Lunar Excursion Module. Toward the end of the ascent boost the response of the LEM to this control moment is quite lively -- about  $50 \text{ deg/sec}^2$ . The moment due to thrust axis offset from the vehicle center of mass may be as much as half the control moment. Vehicle attitude is derived from the IMU gimbal angles and is indicated by the Coupling and Display Unit with a quantization of 40 arc sec. No rate gyros are required by the primary attitude control

system. Simulation of this system using digital control of standard switching logic has indicated that a sampling frequency of about 40 samples/sec would be required. Even at that sampling rate the effects of timing errors are clearly evident. A system using a Kalman filter to estimate attitude, attitude rate, and thrust axis offset has also been simulated.\* The model of vehicle dynamics used in the filter is just an inertia for each axis. This is an incomplete model of three-axis vehicle dynamics, but it is quite adequate. Different modes of control are programmed depending on the magnitude of the estimated error and the estimated offset. For steady-state operation with the offset above a threshold value, limit cycles of the desired form shown in Fig. VII-18 are commanded. In each case, when a control moment is commanded, the time interval during which it should be on is calculated and read into a counter to be counted down by clock pulses. With this form of control, a sampling rate of 10 per sec yields excellent performance.

#### ACCELERATION VECTOR CONTROL

The purpose of the control system during powered flight is not just to control the vehicle attitude but rather to control the thrust acceleration vector,  $\underline{a}_T$ , in response to commands from the guidance system. In fact, it is possible to effect the  $\underline{a}_T$  control directly without even feeding back attitude information, but a system which uses velocity information only requires complicated compensation which must be varied rather carefully with the changing flight condition and vehicle characteristics. It seems clearly preferable in most cases to use attitude feedback to stabilize the vehicle. Having a well-behaved attitude control system to work through, the design of the  $\underline{a}_T$  controller is not difficult.

One approach is open-loop in nature. Having the desired direction of  $\underline{a}_T$  as an input from the guidance system, one can interpret this simply as an attitude command and orient the longitudinal axis of the vehicle in the desired direction for  $\underline{a}_T$ . The discrepancy in so doing is that the thrust acceleration vector is not necessarily aligned with the longitudinal vehicle axis. In addition, if the vehicle center of mass moves off the longitudinal axis, the attitude control system develops a forced error large enough to point the average  $\underline{a}_T$  direction through the offset center of mass location. For a vehicle with a gimbaled engine, the resulting angular error about one axis is

$$\begin{aligned} \text{Angle between actual } \underline{a}_T \text{ direction} \\ \text{and desired } \underline{a}_T \text{ direction} \end{aligned} = \left(1 + \frac{1}{K}\right) \delta_{ss} \quad (\text{VII-3})$$

where  $K$  is the attitude control system forward gain - the gimbal angle per unit attitude error - and  $\delta_{ss}$  is the steady-state engine deflection required to point  $\underline{a}_T$

\* This work done by George W. Cherry.

through the vehicle center of mass. The use of integral control in the attitude control system makes  $K$  in effect infinite, but the angular deviation between the direction of  $\underline{a}_T$  and the vehicle longitudinal axis cannot be accounted for directly by an  $\underline{a}_T$  control system which commands attitude in an open-loop manner. The resulting offset  $\underline{a}_T$  direction feeds back through the guidance system to influence subsequent  $\underline{a}_T$  commands, but there does result from this a forced guidance error at cutoff proportional to the  $\underline{a}_T$  directional error indicated above. In some mission situations this forced error may be tolerable. If the powered flight phase under consideration is followed by another guided phase, such as a translunar or trans-planetary midcourse phase, the cost of the forced error will very likely be measured in terms of the fuel required to accommodate the error in the subsequent phase. In other situations the inaccuracy resulting from the forced guidance error is of more direct consequence.

Such a forced error can be eliminated, if desired, by commanding the attitude control system through a closed-loop scheme in which the actual  $\underline{a}_T$  direction as indicated by the IMU accelerometers is compared with the desired  $\underline{a}_T$  direction and the vehicle commanded to rotate at a rate proportional to the angular deviation. This can be instrumented conveniently by noting that the cross product of the indicated unit ( $\underline{a}_T$ ) with the desired unit ( $\underline{a}_T$ ) is a vector which gives in magnitude and direction the rotation required to carry the indicated  $\underline{a}_T$  into the direction of the desired  $\underline{a}_T$ . If the command is taken to be an angular rate proportional to this angular error, the resulting control law is

$$\underline{W}_c = S(\underline{a}_{ind} \times \underline{a}_{com}) \quad (\text{VII-4})$$

where  $\underline{W}_c$  is the commanded angular rate,  $S$  a sensitivity or gain to be designed,  $\underline{a}_{ind}$  a unit vector in the direction of the indicated  $\underline{a}_T$ , and  $\underline{a}_{com}$  a unit vector in the commanded or desired direction for  $\underline{a}_T$ . If a rate-responding autopilot is used, this rate command can be transformed into body coordinates and applied as the command input. Only pitch and yaw components of the commanded rate in body axes would be computed and used. If an attitude autopilot or attitude control system is used, this commanded angular rate is transformed into the corresponding rate of change of direction for the vehicle longitudinal axis using

$$\dot{\underline{l}} = \underline{W}_c \times \underline{l} \quad (\text{VII-5})$$

which is then integrated to the desired direction for the longitudinal axis.

$\underline{l}$  is a unit vector along the longitudinal axis of the vehicle. It is compared with actual vehicle attitude to provide pitch and yaw attitude errors for the attitude control systems to null. In many mission situations

the computing axis system can be chosen favorably with respect to the general direction of desired  $\underline{a}_T$  so some of the indicated computation can be abbreviated. Toward the end of the powered flight phase when the cut-off condition is approached, the computed direction for the desired  $\underline{a}_T$  tends to change rapidly. However,  $\underline{W}_c$  can be limited in magnitude or even clamped to zero for a brief period of time prior to cut-off with little loss in guidance accuracy.

This closed-loop  $\underline{a}_T$  control renders the system insensitive to any static thrust axis offset or offset center of mass location. The vehicle is simply commanded to rotate until the desired condition is achieved, regardless of what vehicle attitude is required to achieve it. The forced guidance error is in this case proportional to the rate of change of the offset angle rather than the angle itself. It is then primarily the rate of change of vehicle center of mass which designs the system sensitivity,  $S$ . This sensitivity can often be quite low; for example, in the Apollo lunar approach configuration, a gain of 0.06 rad/sec/rad is adequate.

## CHAPTER VII-2

### COASTING FLIGHT CONTROL

During periods of coasting flight when there are no significant forces acting on the spacecraft, control over the vehicle implies attitude control only. In mid-course flight through free space the most common requirements for attitude control result from the requirements for:

Sun pointing - Very often a space vehicle is designed to operate most of the time with one face pointed to the sun. This allows efficient operation of solar cell panels and heat radiators and provides a predictable heat load on the vehicle which eases the thermal control problem. In addition, the sun line constitutes the most easily acquired and identified reference direction in solar space.

Antenna pointing - A communication or telemetry antenna oriented toward Earth is an almost universal requirement. This requirement can be accommodated by vehicle roll control around the sun line plus one degree of freedom of the antenna with respect to the vehicle.

Orienting for navigation sights - Depending upon the design of the on-board optical equipment, vehicle reorientation may be required in taking navigation sightings. Measurement of the angle between a star line and the line of sight to a landmark on a near body, for example, requires orienting the sextant precision drive axis normal to the plane of the measurement. This is a two-degree-of-freedom specification. If for reasons of mechanical simplicity and instrument accuracy only one degree of freedom of the precision drive axis with respect to the vehicle is provided, the additional degree of freedom must be provided by vehicle reorientation about one axis.

Orienting for thrusts - Prior to starting the spacecraft propulsive engine for a thrusting period, the vehicle is oriented with its longitudinal axis in the direction along which velocity is to be gained. This requires a two-axis vehicle reorientation.

The attitude references usually used during midcourse coasting flight are Sun and star lines during quiescent periods and an inertial reference during reorientations. A two-axis Sun sensor serves as the reference for control of one axis of the vehicle along the Sun line. The degree of freedom in roll about the



Sun line is controlled against a reference provided by a star tracker. The star Canopus is a popular choice for the reference star because of its location well out of the ecliptic plane. The Canopus line thus makes a large angle with respect to the Sun line as seen from a vehicle travelling near the ecliptic, and it is not confused by neighboring stars of comparable magnitude. Orienting for a navigation sight or a thrust requires giving up one or both of these optical references. An inertial reference must then be provided. The accuracy required of such a re-orientation is not so demanding as to require the use of the navigation system IMU. A set of body-mounted single-degree-of-freedom integrating gyros is a convenient and simple alternative. If these gyros are used as pulse-rebalanced instruments, communication with the central digital computer is particularly easy. A two-axis reorientation is accomplished by rotating from the reference orientation through a prescribed angle about one axis followed by a prescribed rotation about a second axis. The vehicle control system holds the third gyro at null during this process. The reference orientation can then be recovered by executing negative rotations in the reverse order.

The sources of control moments during midcourse space flight are reaction jets or momentum exchange systems. Reaction jets can employ either cold or hot gas - hypergolic thrusters being preferable for the larger vehicles. Cold gas systems, most commonly employing pressurized nitrogen, have been used in many missions, but they have a restricted specific impulse capability - about 60 to 80 sec - and require even more weight in tankage than the weight of control gas stored. On-off control systems for vehicles using reaction jets are of the same type as those discussed in the preceding chapter under "Attitude Control with a Fixed Engine". As described there, the thruster duty cycle in steady-state limit cycling with no external moments acting on the vehicle depends on the minimum impulse which can reliably be commanded and the maximum attitude error which can be tolerated. The presence of an external moment, such as a moment due to unbalanced solar pressure forces, can actually be used to advantage to further reduce the rate of control fuel consumption. But this saving can only be achieved if the control system is capable of recognizing the presence of the moment and only thrusting against it - waiting for the external moment to return the attitude error to the limit.

Momentum exchange systems derive moments either by accelerating wheels about their spin axes or by precessing wheels which are maintained continuously spinning as gyros. In either case it is possible to design a linear control system around such a torque generator. Steady-state operation of such a system does not necessarily include a limit cycle, and very accurate attitude control - essentially

as accurate as the basic attitude reference - can be maintained if needed. On the other hand, there is an upper limit to the amount of angular momentum such a system can exchange. The saturated condition is represented by an inertia wheel spinning at its maximum speed in the case of the accelerating wheel system, and by the gyros having turned through 90 degrees in the case of the precessing gyro system. Control saturation must be prevented either by adjusting the attitude or configuration of the vehicle to prevent an external moment from acting in the same sense over a long period of time, or by applying a moment to the vehicle with a reaction jet system in such a sense as to move the momentum exchange controllers away from the saturated condition.

A number of forms of control logic have been devised for use with reaction jet controllers in an effort to achieve some approximation to linear, or proportional, control. The simplest of these are pulse rate modulation and pulse width modulation. In the former case, control torque pulses of constant width are commanded to recur at a rate proportional to a control signal which may be attitude error or vehicle-rate-damped attitude error. The major disadvantage of this logic is the high pulse repetition rate at large errors when it would be less wearing on valves and more efficient in fuel use to simply leave the control jets on. In the latter case, control torque pulses are commanded to recur at a fixed rate - the width of these pulses being proportional to the control signal. The disadvantage of this scheme is the repeated operation of the thrusters even at small errors when it would be preferable to leave them off.

More sophisticated schemes attempt to relieve these disadvantages through additional data processing. One such scheme due to R. A. Schaefer<sup>(3)</sup> is known as the Schaefer modulator or pulse ratio modulator. The control logic is pictured in Fig. VII-20. The variable  $x(t)$  shown in that figure is a function of the rate-damped attitude error signal; it must range between 0 and + 1, and is often taken in the form shown in Fig. VII-21. In operation, the control logic moves repeatedly around the flow graph of Fig. VII-20, turning the appropriate jets on long enough for the integral of  $1 - x(t)$  to accumulate to  $T_{min}$ , then turning the jets off long enough for the integral of  $x(t)$  to accumulate to  $T_{min}$ . Clearly, if the control signal remains within the dead zone of Fig. VII-21, the jets would remain continuously off, and if the control signal remains in the saturated regions of that figure, the jets would remain continuously on. For intermediate values of the control signal, the control jets are pulsed on and off, the pulse width, pulse rate, and pulse duty ratio all varying with the control signal. If  $x(t)$  is treated as quasi-stationary, the operating characteristics are:

$$\begin{aligned} \text{Pulse width} &= t_{on} \\ &= \frac{T_{min}}{1 - x} \end{aligned} \tag{VII-6}$$

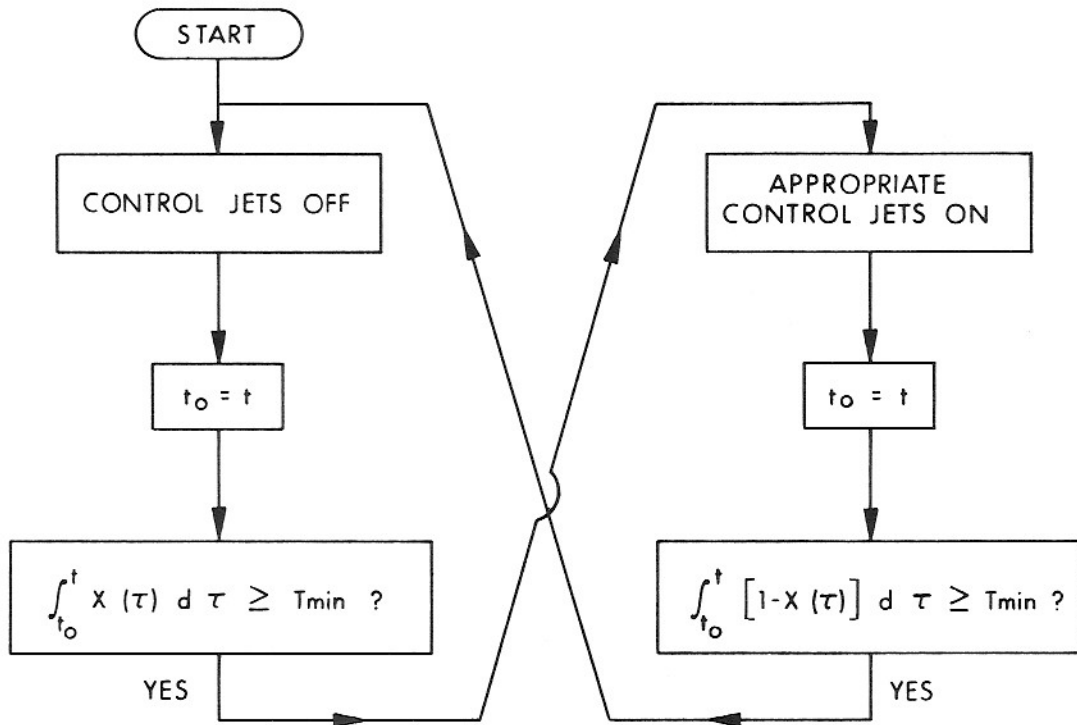
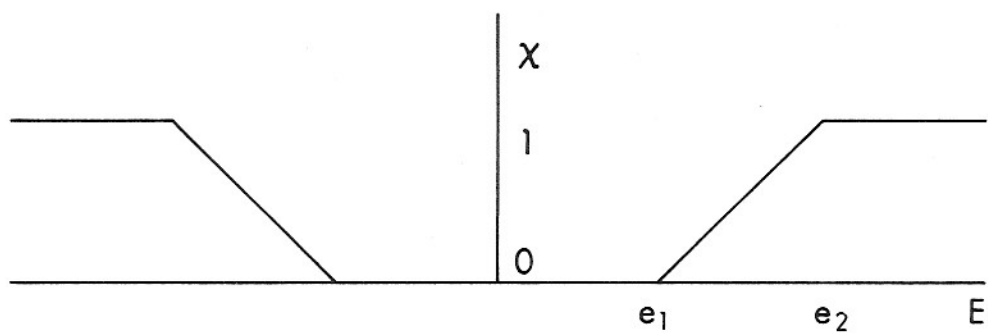

Fig. VII-20 Control Logic for Schaefer or Pulse Ratio Modulator



$$E(t) = \theta_{\text{comm}} - \theta(t) - k \dot{\theta}(t)$$

Fig. VII-21 Typical Definition of  $x(t)$

$$\begin{aligned} \text{Pulse rate} &= \frac{1}{t_{\text{on}} + t_{\text{off}}} \\ &= \frac{1}{T_{\text{min}}} x(1 - x) \end{aligned} \tag{VII-7}$$

$$\begin{aligned} \text{Duty ratio} &= \frac{t_{\text{on}}}{t_{\text{on}} + t_{\text{off}}} \\ &= x \end{aligned} \tag{VII-8}$$

The variable  $x$  thus measures directly the duty ratio of the control history. The pulse width and pulse rate are plotted in Fig. VII-22 for  $T_{\text{min}} = 10$  millisec. It may be seen from these curves that for small values of  $x$  (control signals near the dead zone) the pulse ratio modulator acts essentially as a pulse rate modulator using minimum width pulses. For larger errors, the pulse width increases as desired to prevent very large pulse rates. The maximum pulse rate for quasi-static  $x$  is  $\frac{1}{4T_{\text{min}}}$ .

Even the performance of such a control logic leaves something to be desired. A typical response to a command input using the pulse ratio modulator is shown in Fig. VII-23. The control jets are turned on and off unnecessarily often before reaching the final limit cycle. If the performance of the system (its acceleration level and time lags) is known well enough, only two control pulses are needed to enter the limit cycle. A set of switching curves which achieve this is shown in Fig. VII-24. The slope of the straight-line torque-off switching lines may be varied as desired to compromise between fuel used and response time. If a digital controller is employed, switching logic such as this is easy to implement.

Choice of a momentum exchange or reaction jet system, or both, should be based on an analysis of system weight, performance, and reliability. If high accuracy attitude control is required, such as in the case of a vehicle carrying a large telescope fixed to the body, a momentum exchange system would seem to be a clear choice. Most space missions do not require exceptional attitude accuracy, however, and a reaction jet system may be selected on the grounds of reliability. The reliability advantage would be especially significant if one interpreted successful operation of a momentum exchange system to require the operation of a reaction jet system used for desaturation as well. If it is understood at the outset of a system design that accurate attitude control is costly, the vehicle and its subsystems can often be designed with a view to avoiding the need for accurate control. For example, it is easy to imagine designs for an optical measurement unit which would require

precise vehicle control to track some reference line. But it may also be possible to design that unit, as in the Apollo system, to tolerate a slow drift in vehicle attitude. Rather than controlling the vehicle precisely to a reference condition, the vehicle is allowed to drift through the reference condition - and the event of passage through the reference is noted.

An additional factor bearing on the choice of a momentum exchange or reaction jet system, especially for space missions of extended lifetime, is difficult to assess quantitatively. This is the possibility of consuming all available fuel for a reaction jet system. A momentum exchange system has the advantage of consuming a quantity which can be replenished in space - electrical energy. There is no obvious threat of running out. But a reaction jet system consumes mass, which cannot yet be replenished in space. So although the analysis may show a very low probability of exhausting all control fuel, the threat of this possibility hangs over the mission during its entire lifetime.

During its midcourse flight, the Apollo spacecraft<sup>(4)</sup> effects attitude control with a system of hypergolic rocket engines which are also used for vernier translational control when needed. They employ hydrazine and nitrogen tetroxide, or variations of them, as fuel and oxidizer. They are capable of reliable operation in pulses as short as 10 milliseconds. Sixteen of these engines are mounted on the sides of the service module in quadruple sets at 4 locations. They are normally fired in pairs to produce control couples. A variety of operational modes can be selected by the crew. These are suggested by the simplified block diagram shown in Fig. VII-25. In the primary mode, the Apollo Guidance Computer operates the jet solenoid valve drivers directly based on attitude reference information only. The analog Stabilization and Control System is used as a back-up mode. It employs both attitude reference and rate gyro information. Crew-operated modes include attitude-hold and rate-command modes in addition to direct actuation of the reaction jets by the pilot through a three-axis hand controller.

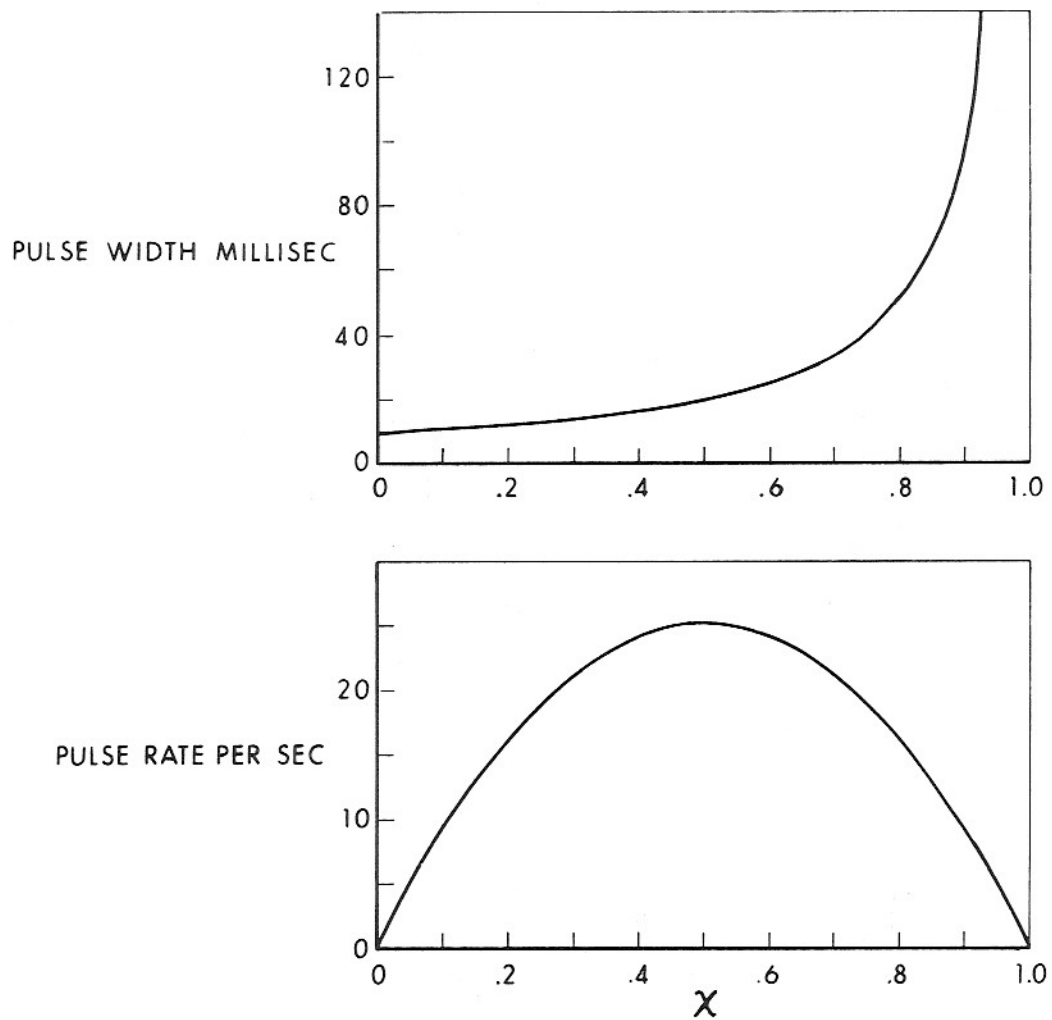

Fig. VII-22 Performance of the Pulse Ratio Modulator

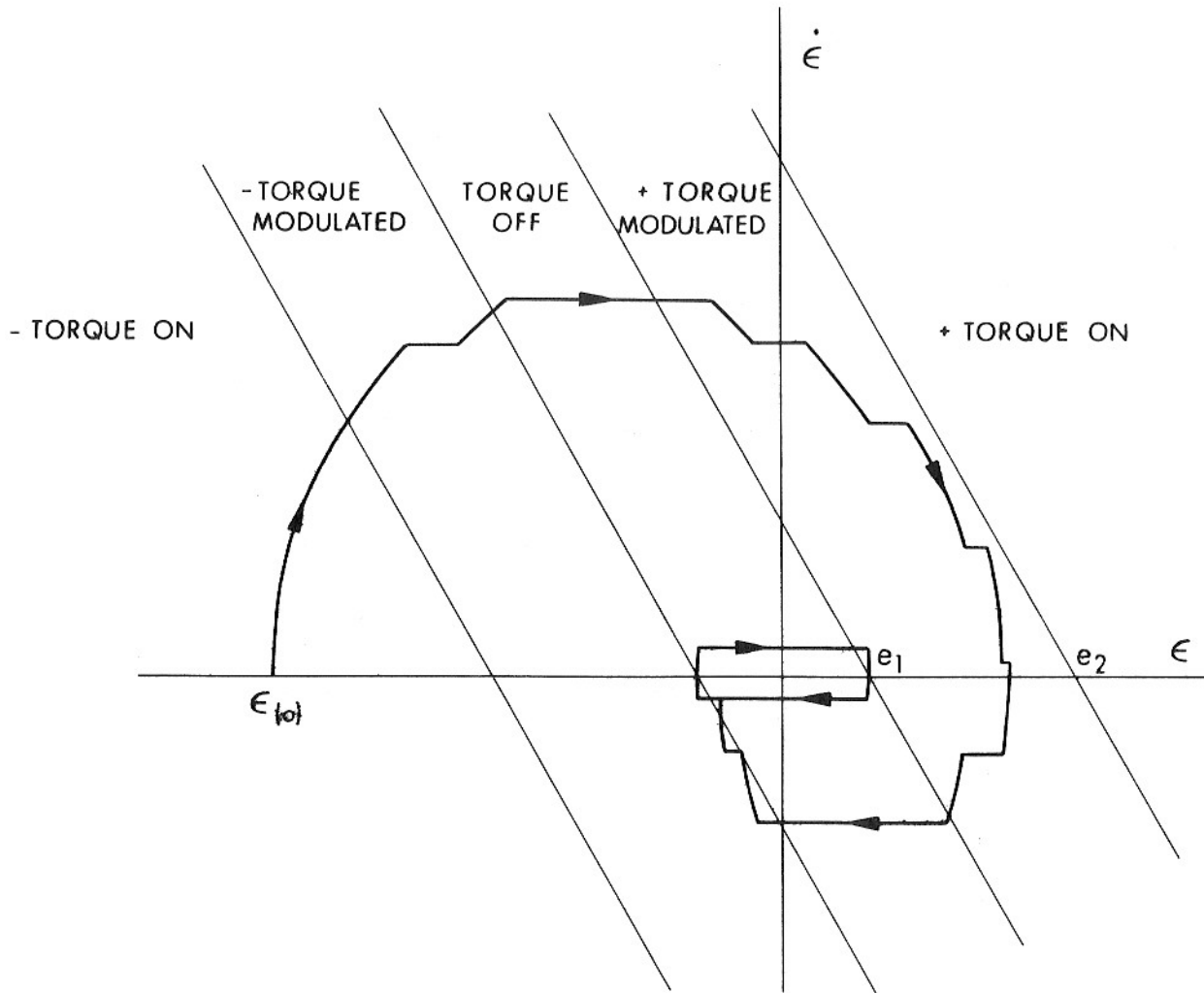

Fig. VII-23 Typical Step Response of Pulse Ratio Modulated System



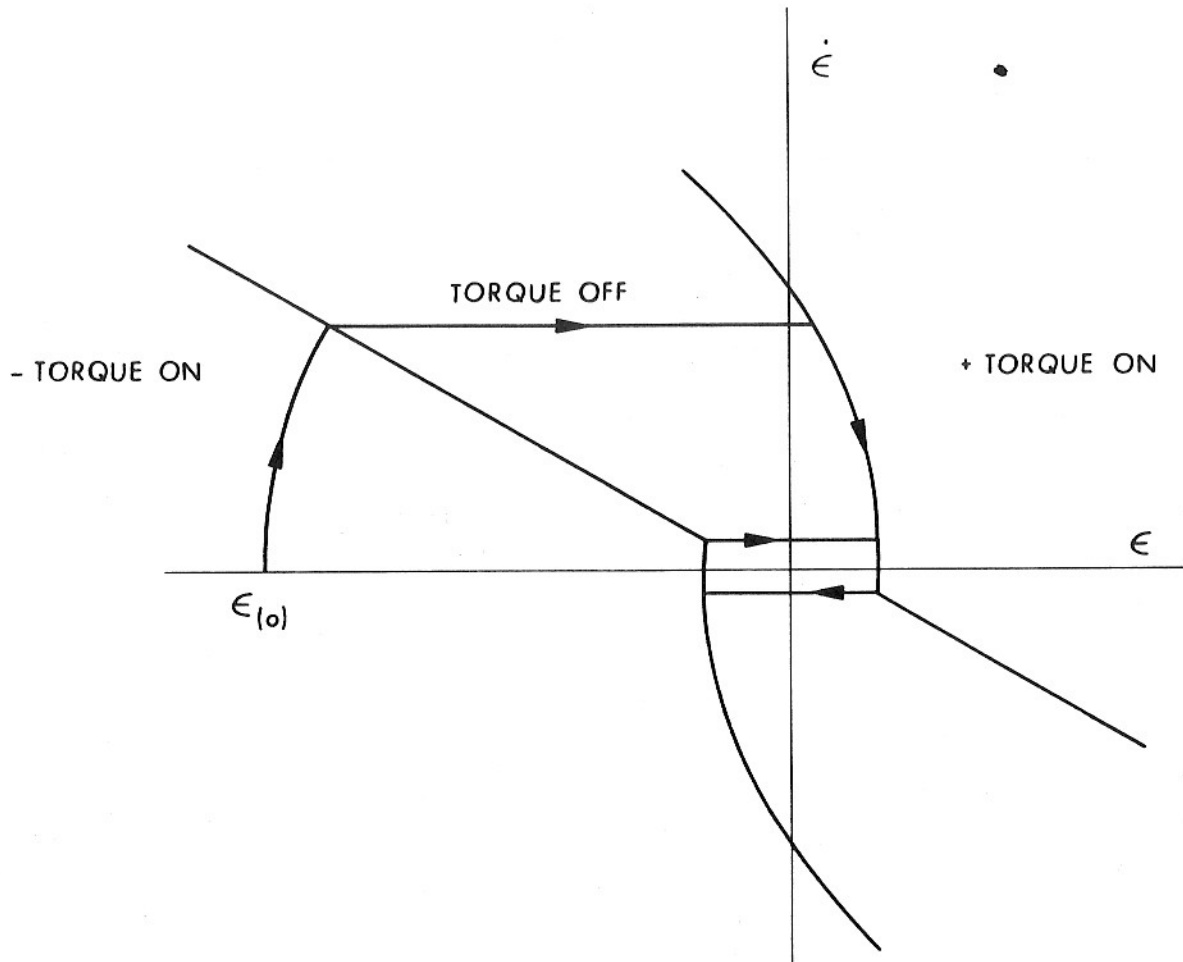

Fig. VII-24 Step Response with Straight-Line and Parabolic Switching Curves

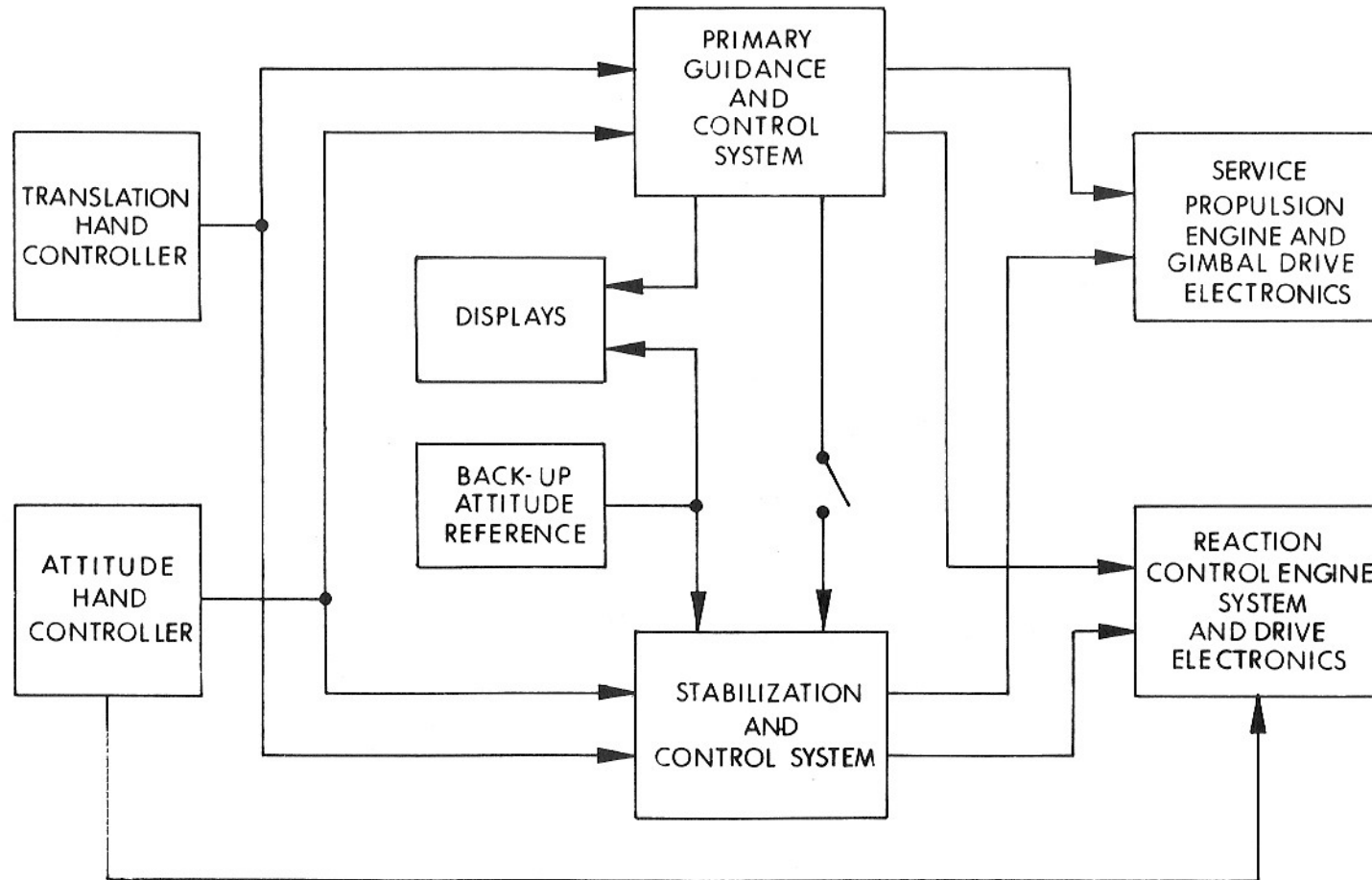

Fig. VII-25 CSM Guidance and Control System Block Diagram, Block II Configuration

## CHAPTER VII-3

### ATMOSPHERIC FLIGHT CONTROL

#### INTRODUCTION

A significantly different control problem is encountered in the high-speed atmospheric flight phase or phases of a space mission. Attention is here centered on flight following entry into a planetary atmosphere in which the path of the vehicle is controlled entirely or primarily by control of the aerodynamic force acting on the vehicle. This would include the final phase of an Earth-return mission - re-entry into Earth's atmosphere and control of the vehicle to a desired landing point. It would include a pass through the atmosphere of a planet for the purpose of reducing the energy of the vehicle's orbit relative to that planet prior to a propulsive transfer into a planetary orbit. We do not consider in this chapter the brief period of atmospheric flight which occurs at the beginning of a mission - the boost from the pad out of Earth's atmosphere. The control problem during boost is dominated primarily by the propulsive force rather than the atmospheric force and was considered earlier in Chapter VII-1.

Control over the flight path of the vehicle as well as attitude control of the vehicle itself is discussed here. Flight path control is also called guidance, and as such could well have been treated in Part III. However, the distinction between guidance and control is arbitrary, and it was thought better to consolidate in one section the discussion of the unique problems of guidance and control in the high-speed atmospheric flight situation.

#### FLIGHT PATH CONTROL

The discussion of this section will center on the re-entry and landing control problem. An atmospheric braking pass which involves entry into and subsequent exit from a planetary atmosphere is in fact a truncated version of a landing trajectory, which often requires a controlled skip out of the atmosphere to achieve the required range. The geometry of entry trajectories leading to a landing point is indicated in Fig. VII-26. The direction of approach relative to Earth is constrained by the nature and timing of the mission. However, when the spacecraft is a substantial distance from Earth its velocity vector is oriented nearly along the direction to Earth's center, so it is possible with little expenditure of fuel to rotate the plane of the approach trajectory arbitrarily about the local vertical line. Thus it is possible

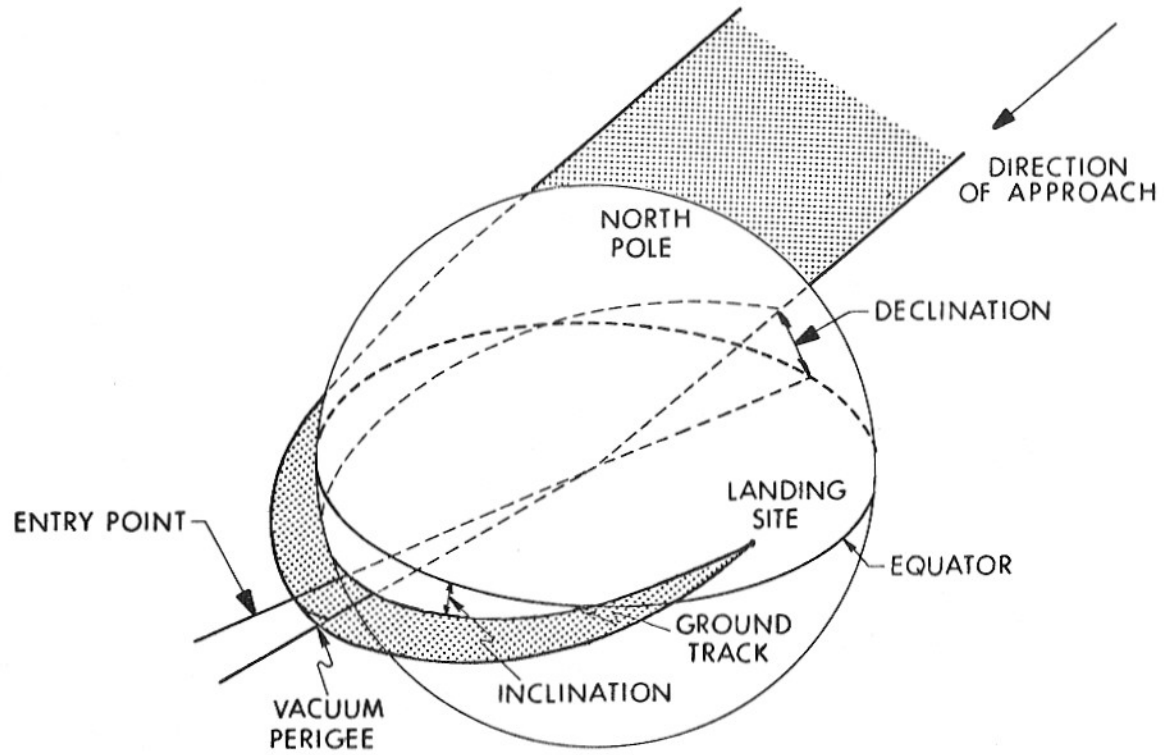

Fig. VII-26 Geometry of Entry Trajectories

to orient the trajectory plane so the vehicle will fly to any selected landing point with no lateral control under nominal conditions. The trajectory plane required to achieve this is not immediately obvious because the landing point is moving due to the rotation of the Earth and the vehicle without lateral control does not fly in an inertial plane. Prior to entering significant atmosphere, the vehicle's trajectory does lie essentially in a single inertial plane. But except for winds, the atmosphere rotates with the Earth and the vehicle is gradually captured by the rotating air mass, and eventually flies essentially in a plane which rotates with the Earth. None-the-less, it is possible to determine by iteration a plane for the approach trajectory such that no lateral control would nominally be required to fly to the landing point. The required range after entry is then given by the distance from the entry point to the landing site. The entry point is defined as that point at which the approach trajectory passes through an arbitrary altitude - often taken to be 400,000 ft. The entry point thus occurs slightly before the perigee point for the approach trajectory computed as if there were no atmosphere.

This problem is further constrained by the desire to hold the azimuth of the approach to the landing site within certain bounds. This requirement is due to the desire to fly over well-instrumented areas and the desire to avoid hostile areas. This hostility may be either natural or political. Especially in a manned mission one would want to avoid over-flying certain countries and would want to avoid the colder regions of the Earth. If it were possible to select and reach a landing site nearly along the line of the approach direction, then by rotation of the approach trajectory plane about the local vertical line while the vehicle is some distance from Earth it would be possible to approach that landing point with any desired azimuth. But in many cases this would represent a severe re-entry range requirement. The other extreme is a landing point near the plane normal to the approach direction. In that case the plane of the approach trajectory must be taken to give a reasonable lateral range requirement after entry, and very little freedom remains to adjust the approach azimuth. These requirements may very well conflict to such an extent that it is impossible to select one or even several landing sites which can be reached by the vehicle with the desired azimuth or orbital inclination under all conditions of timing of the mission. In that case an alternative is to use a water landing and move the landing point continuously with the changing mission situation. In the Apollo mission, for example, the direction of return to Earth depends on the declination of the moon which changes from day to day. A band of possible landing sites is chosen at low latitudes in the Pacific Ocean so the actual landing point toward which the re-entry system guides is moved from day to day if a take-off is delayed.

Another concept associated with atmospheric entry trajectories is that of the entry corridor. This is simply recognition of the fact that a given vehicle cannot fly an acceptable atmospheric flight for arbitrary initial conditions at the entry point. If the flight path angle at that point is too steep, the vehicle will later suffer excessive aerodynamic loading even if its maximum lift is directed upward. Or if the flight path angle at entry is too shallow, the vehicle will exit the atmosphere again with a supercircular velocity even if its maximum lift is directed downward. These boundaries of entry flight path angle are often taken to define the corridor of acceptable entry conditions. The corridor can also be specified in terms of the range of acceptable virtual perigees - the perigee altitude computed as if there were no atmosphere. The corridor depends on the specific definitions of its boundaries, such as 10 g's for the undershoot boundary, and on the entry velocity and vehicle L/D capability. For a lunar return with an entry velocity of about 36,000 ft/sec and  $L/D=1/2$ , the 10 g entry corridor is about 2.5 degrees wide in terms of entry flight path angle. For a planetary return with an entry velocity of perhaps 50,000 ft/sec the same corridor shrinks to about 0.7 degree.

For lunar return conditions, the range control which is available to vehicles of different hypersonic L/D capability is shown in Fig. VII-27. (Data from Ref. 5) For each L/D, the short range limit is determined by the 10 g constraint. The maximum range increases essentially without limit with decreasing entry flight path angle. This is indicative of trajectories which turn upward after entry and exit the atmosphere for a long ballistic skip. Such long range performance is not necessarily usable in practice due to the extreme sensitivity of range to errors in exit conditions. The data of Fig. VII-27 is for constant L/D flight. The minimum range for a given initial flight path angle and L/D capability can be improved somewhat by controlling the lift during the flight. The gain is realized by reducing the lift as the vehicle approaches a 10 g acceleration so as to reduce the total aerodynamic load and prevent a violation of the 10 g limit. The lateral control capability of vehicles of various hypersonic L/D as a function of the downrange distance travelled is shown in Fig. VII-28 (Ref. 5)

Some of the basic requirements which must be placed on an atmospheric flight control system are the following:

- Avoid excessive aerodynamic loads.
- Avoid uncontrolled skip-out in the presence of navigation, vehicle, and atmospheric uncertainties.
- Achieve the necessary range and crossrange.
- Maintain a suitably low heating load, perhaps heating rate.
- Achieve adequate accuracy at landing point.

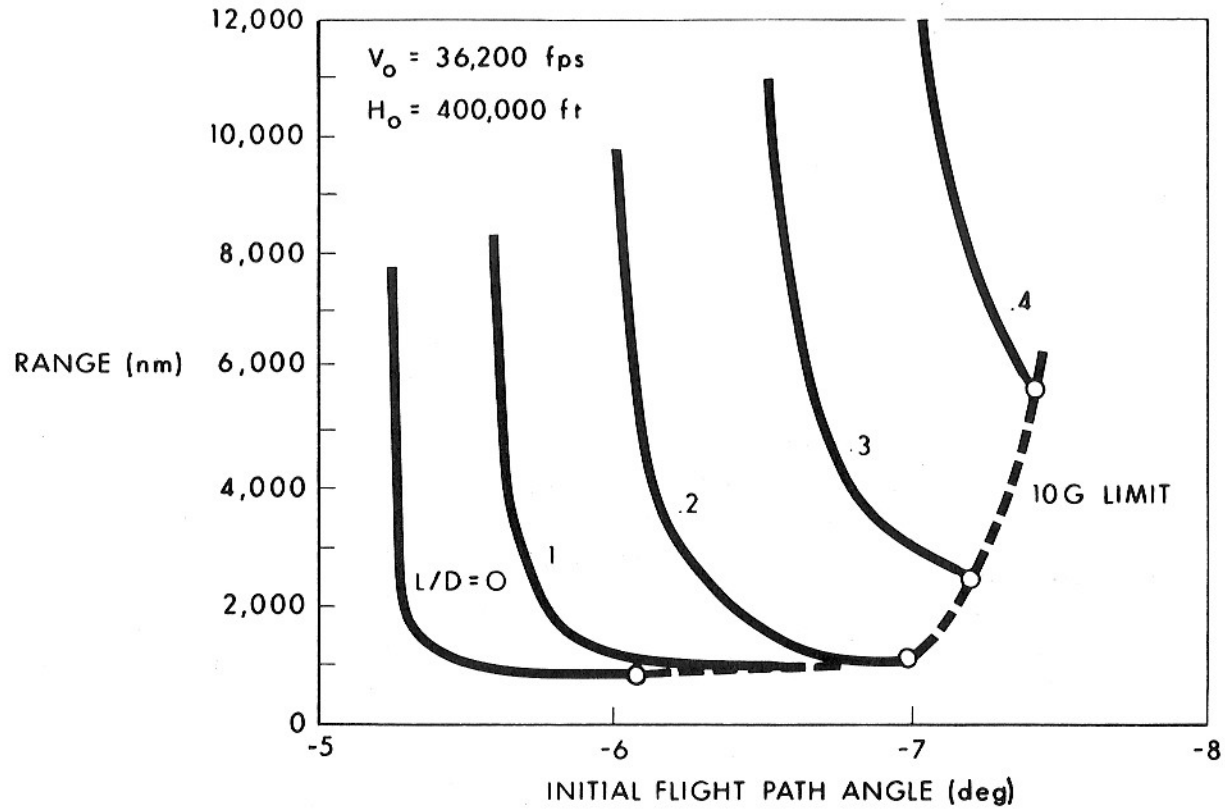

Fig. VII-27 Re-entry Range Capability for Lunar Return Conditions, Constant L/D

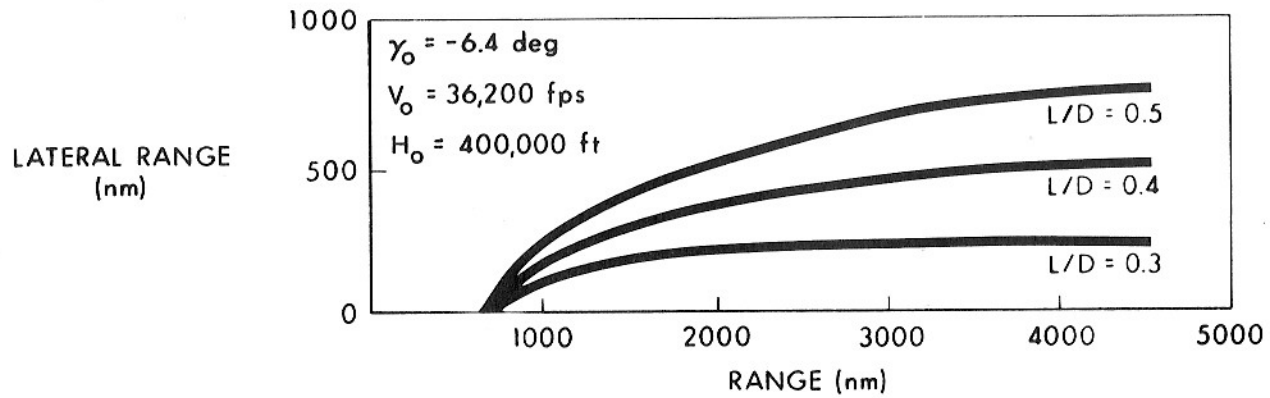

Fig. VII-28 Lateral Range Capability for Lunar Return Conditions, Constant L/D



These requirements will be considered within the context of a standard flight plan as indicated in Fig. VII-29.

Pre-Entry - A large part of the responsibility for meeting the first two requirements above rests with the midcourse guidance system. Throughout the mission each guided phase has been followed by another, so the cost of guidance inaccuracies is measured primarily in terms of the fuel required to accommodate the errors in the next mission phase. A more serious cost, however, is associated with the last midcourse correction prior to entry into an atmosphere. That correction must yield entry conditions within the acceptable corridor or it will be beyond the capability of the atmospheric flight control system to fly a proper trajectory. For reasons of simplicity and reliability, the midcourse corrections prior to the last one may be made under the control of an abbreviated inertial system - such as one based on three body-mounted pulse-rebalanced gyros for attitude control and a single body-mounted longitudinal accelerometer for engine cut-off. But due to the premium on accuracy for the last correction, it will be delayed as long as possible so as to benefit from the best possible navigation information, and be executed under the control of the primary instruments of the guidance and navigation system. The IMU will have been aligned for this purpose, and prior to atmospheric entry the inertial navigator is provided with initial conditions.

Initial Pull-Up - During the initial portion of the entry trajectory, attention may well be centered not on reaching the landing point but on avoiding excessive g's or uncontrolled skip-out. Control during this phase may be considered logical in nature - the decision to direct lift up or down depending on the indicated entry conditions and continuing trajectory. If not all the lift of which the vehicle is capable is required to avoid excessive g's or skip-out, and if substantial lateral range is required to reach the landing point, at least some component of lift may be used in the lateral direction. To achieve near-maximum lateral range, it is essential to begin turning the trajectory as early as possible. The end objective of this phase might be taken to be a horizontal flight path angle at a suitably low g level and a low enough velocity so the vehicle can maintain capture in the atmosphere. This means the velocity and altitude at the end of pull-up must be such that the maximum lift of which the vehicle is capable is nearly enough to balance the excess of centripetal over gravitational acceleration.

Controlled Climb to Atmospheric Exit - In most instances, if the vehicle is to make the required range it must climb and do an out-of-atmosphere skip to a new entry point close enough to the landing point so the remaining range can be covered in a steady glide. This is the most sensitive maneuver of the re-entry flight. The range achieved in the ballistic portion of the flight is shown in Fig. VII-30

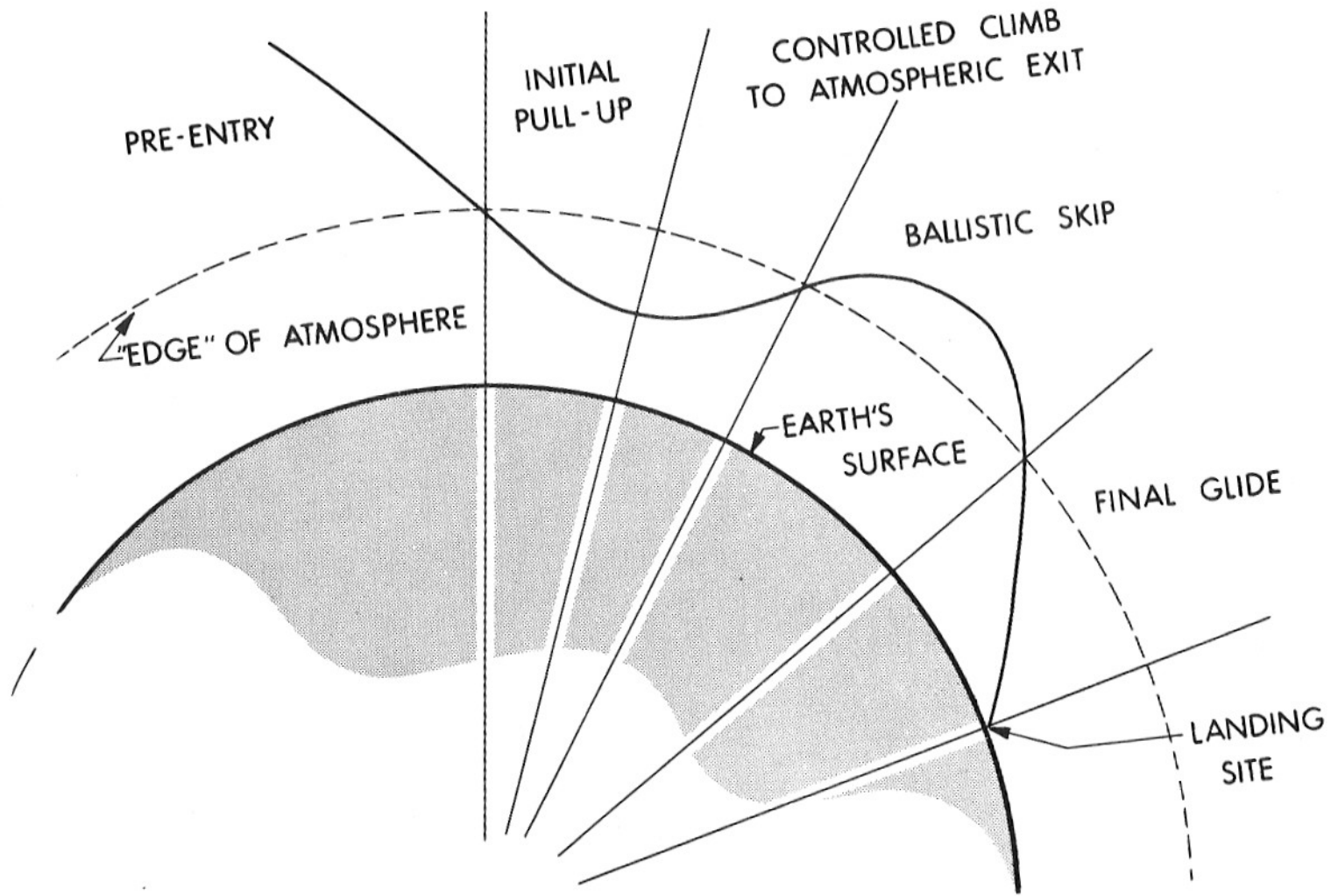

Fig. VII-29 Typical Re-entry Trajectory

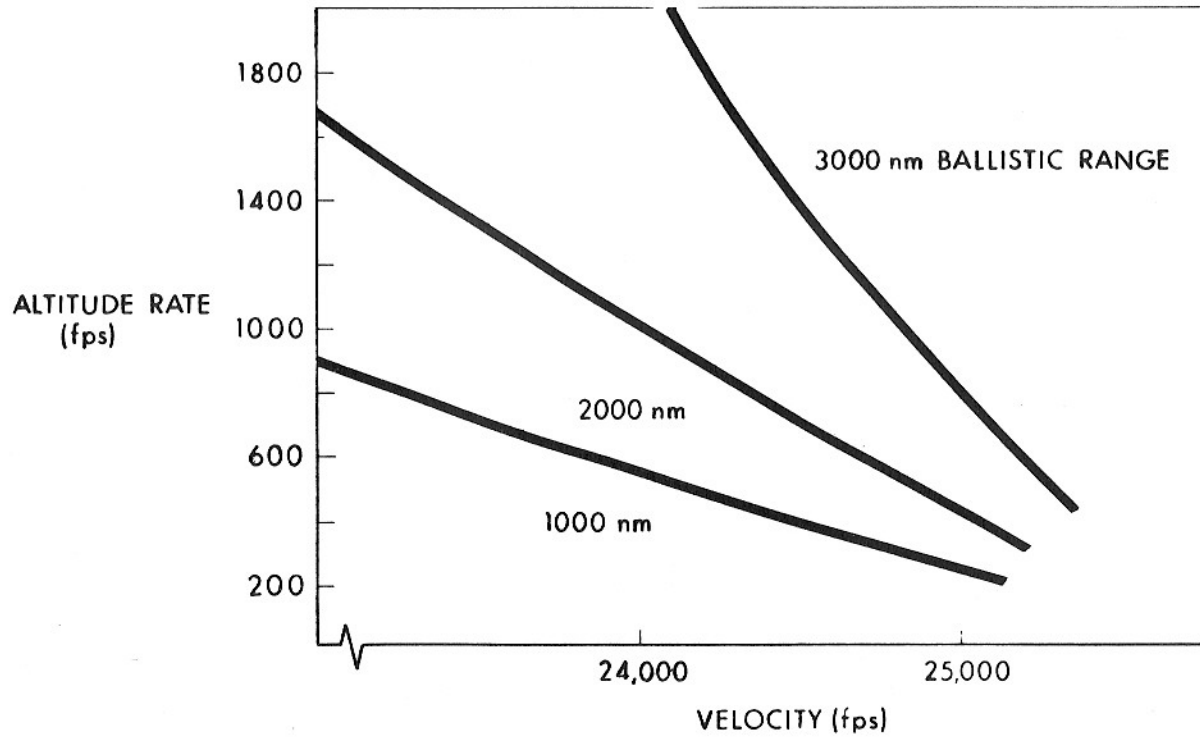

Fig. VII-30 Ballistic Range for Different Exit Conditions

as a function of velocity and altitude rate at exit which is taken as 400,000 ft altitude. It is clear that there is a one parameter infinity of exit conditions which will realize the desired ballistic range. For a given required range, a lower exit velocity can be compensated for by a steeper flight path angle resulting in a larger altitude rate. These different trajectories resulting in the same ballistic range have very different sensitivities to errors in knowledge of or control over exit conditions. This is indicated in Fig. VII-31 which shows the sensitivity of ballistic range to exit velocity and in Fig. VII-32 which shows the sensitivity of ballistic range to exit altitude rate. In each case the sensitivity decreases sharply with velocity, so a slow, steep exit is preferable to a fast, shallow exit from the point of view of error sensitivity. For example, if 2000 nm range is required in the ballistic portion of the flight, it can be achieved with an exit velocity of 24,600 fps and an altitude rate of about 680 fps or an exit velocity of 25,400 fps and an altitude rate of about 230 fps - among other combinations. The range derivatives with respect to both velocity and altitude rate are roughly 3 times larger in the second case than in the first. Since the navigation information used by the guidance system may have appreciable errors, due chiefly to the imperfect initial conditions supplied to the navigator at the end of midcourse flight, control over sensitivity to errors must play a dominant role in the design of the flight control system for this phase of the flight.

Two fundamentally different approaches to this flight control problem are often considered: predicted final value control and nominal-following control. The final value control scheme involves prediction of the effect of an assumed control history on the conditions at the end of flight. This trajectory prediction can be done analytically if possible, or otherwise by high speed computer runs starting from the indicated present state. If the terminal conditions are not as desired, in this case if the terminal range is not the desired range, the assumed form of the control is altered and a new predicted trajectory is computed. This iterative process converges on a suitable control history. This form of control can accommodate large off-nominal perturbations in initial conditions, it does not attempt to fly back to a pre-selected nominal trajectory which may be a costly maneuver, and with proper choice for the form of control history it can direct the vehicle along trajectories which are desirable for other reasons than terminal accuracy - such as low heat load. A nominal-following control scheme would be undesirable if it referred to a nominal trajectory selected prior to the start of the mission. This would be a severe constraint for a flight control system which must be able to bring the vehicle home under the wide variety of circumstances resulting, for example, from aborts at all possible times during the mission. However, for this climb-to-exit phase of re-entry flight it has been demonstrated <sup>(5)</sup> that some simplifying approximations to trajectory equations permit on-board calculation of a reference trajectory which is based on the existing

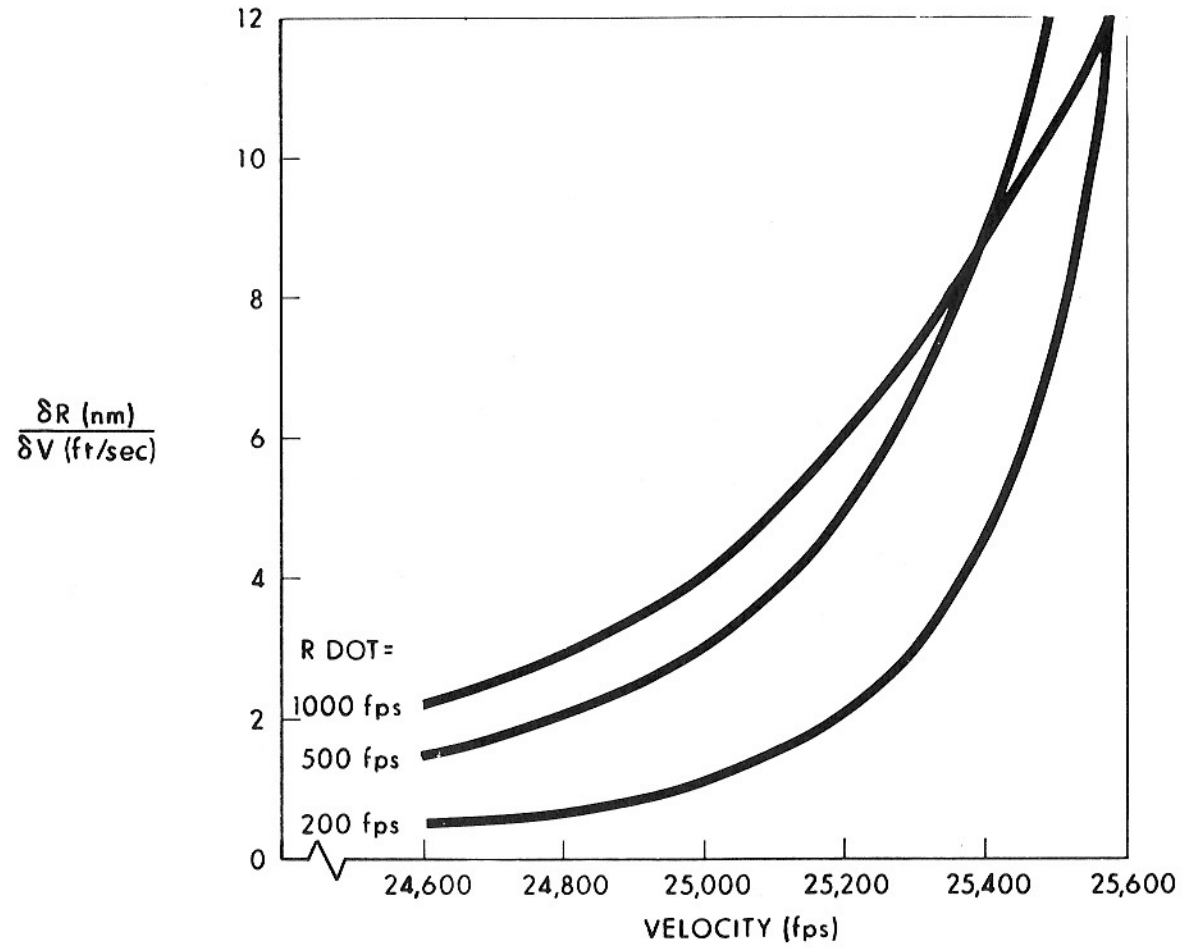

Fig. VII-31 Sensitivity of Ballistic Range to Exit Velocity

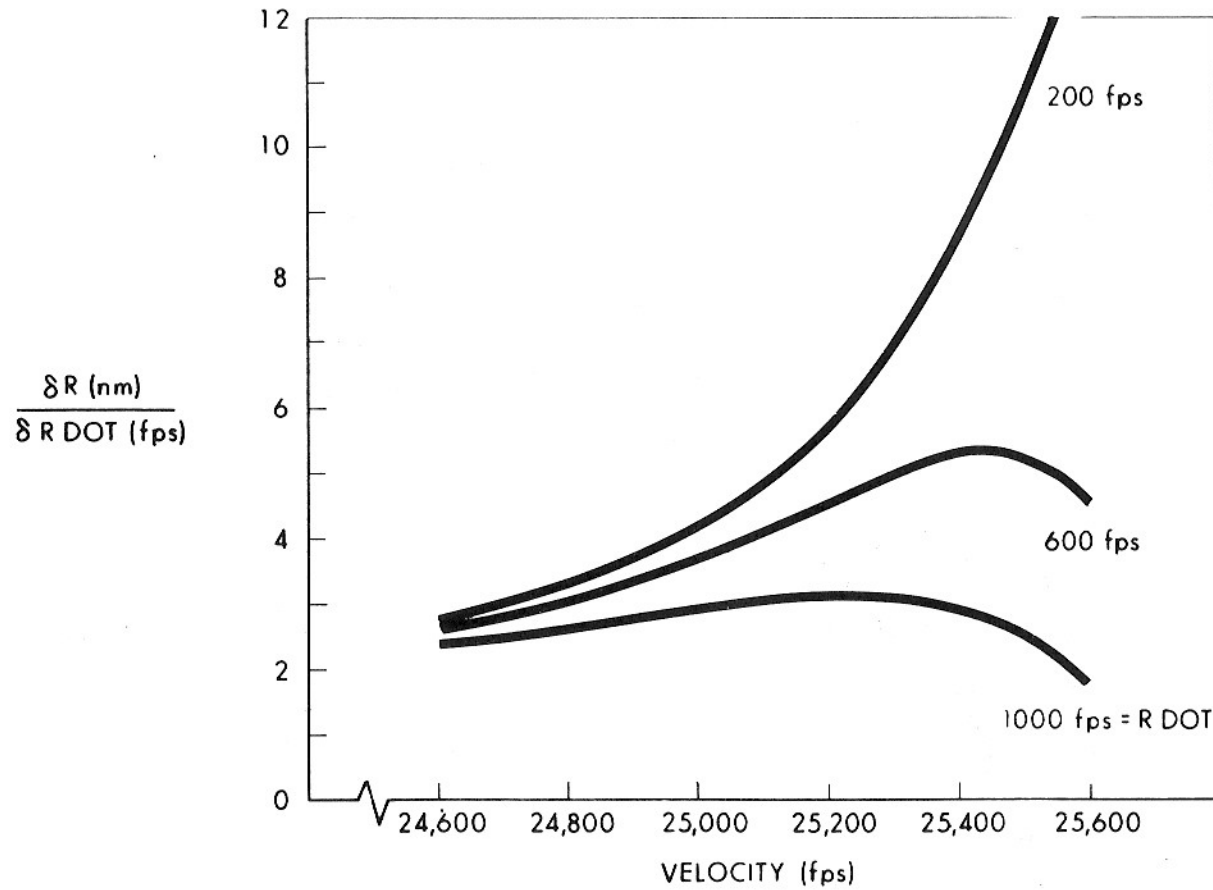

Fig. VII-32 Sensitivity of Ballistic Range to Exit Altitude Rate

conditions at the end of the initial pull-up and which reflects the conditions desired at exit so as to achieve the required ballistic range. With such an analytical reference trajectory available, the nominal-following scheme has complete flexibility. Moreover, with the feedback gains in the nominal-following system time programmed to minimize the mean squared range perturbation at the end of ballistic flight due to the ensemble of expected errors in navigation information, a surprising degree of insensitivity to these errors is achieved.<sup>(6)</sup> In spite of a range sensitivity to altitude rate which is typically about 3 nm/fps, this system yields trivial control errors with errors in knowledge of altitude rate as large as 200 fps. This insensitivity to error is probably the most important criterion by which to judge the merit of a flight control system for this critical phase of the flight.

Ballistic Skip - No effective aerodynamic control can be exercised during this phase of the flight. For a vehicle with no propulsive capability remaining, this skip is then uncontrolled. This just serves to emphasize the importance of achieving accurate exit conditions - or what is closer to the case, achieving a combination of errors at exit such that a desired ballistic trajectory results.

Final Glide - Again during the final glide to the landing point either predicted final value control or nominal-following control can be employed. If the vehicle has a reasonable lifting capability, say L/D of 0.5 or greater, a particularly simple range predictor is available for use in a final value control scheme. If the control history is taken to be just a constant L/D, the range to which the vehicle will glide is given to good accuracy by the simple equilibrium glide relation

$$\text{Range angle} = \frac{1}{2} \frac{L}{D} \ln \left( \frac{1 - \bar{V}_f^2}{1 - \bar{V}_i^2} \right) \quad (\text{VII-9})$$

where  $\bar{V}_i$  and  $\bar{V}_f$  are the initial and final velocities divided by the circular satellite velocity at some mean altitude. In fact, the form of this range expression is so simple as to allow direct calculation of the required L/D given the range to go. This expression for L/D, modified by correction terms to account for the fact that the initial altitude and flight path angle may not be consistent with equilibrium glide at the required L/D<sup>(7)</sup>, results in a direct closed-loop flight control system for the final glide.

The Apollo vehicle has an L/D of only 0.3. With such little lift, the assumptions underlying the equilibrium glide relations are not well satisfied, and the nominal-following philosophy seems preferable. This scheme is especially amenable to this last phase of the flight since the ballistic skip was intended to bring the vehicle into the final glide at a nominal range from the landing point. Thus trajectory data calculated before the start of the mission and stored in the on-board computer is perfectly usable in this phase. The nominal distance flown by the

Apollo vehicle in this final glide phase is about 640 nm and the control capability for accommodating range errors at the end of the ballistic skip is about  $\pm 200$  nm. It is expected that the errors will be no more than about 20 nm.

## VEHICLE CONTROL

The result of the flight control schemes discussed above is a desired or commanded L/D. It still remains for a vehicle control system to execute these commands. For many reasons it would be desirable to have full aerodynamic control available; that is, to be able to roll to any desired bank angle and to trim the vehicle to any desired lift or L/D. But aerodynamic trimming poses a most difficult problem. This requires something like control surfaces or trim tabs which will not burn up when deflected into the hot gas flow, will not jam if heat-protecting material from the vehicle forebody flows back and condenses, which are reasonably small and lightweight, have modest power requirements for actuation, and so on. It seems fair to say that this problem has no satisfactory solution at present.

A perfectly reasonable alternative is the use of a fixed vehicle trim at some L/D and the use of roll only to control the flight. In this case the L/D referred to throughout the discussion of in-plane flight is interpreted as the vertical component of L/D. The vehicle is then rolled to whatever bank angle is required to achieve the commanded vertical component of L/D. The resulting lateral component of lift can be directed either to the right or left. An evident logic for lateral control is to reverse the direction of roll when the predicted lateral error exceeds some limit. This limit can be set large initially and decreased during flight - perhaps in proportion to the vehicle's lateral control capability. Roll control in the Apollo mission is exercised by on-off operation of hypergolic thrusters using attitude information derived from the IMU gimbal angles. The vehicle is aerodynamically stable in pitch and yaw; additional control engines are used for rate damping about these axes.

The re-entry flight control problem for lunar return missions seems well in hand. The problem becomes much more challenging as one looks ahead to planetary return missions. It may be that new techniques will be required to satisfactorily solve that problem. The entry corridor will be considerably narrowed; perhaps large area controllable drag devices may be useful to broaden the corridor or propulsion may be useful to rotate the flight path somewhat at a strategic point during entry. The vehicle energy which must be dissipated in the atmosphere will be much greater, thus complicating considerably the problem of heat protection. Perhaps different flight plans can be used to assist in this problem - very long flights around the Earth at high altitude to dissipate the energy under radiative equilibrium may be useful. Trajectory sensitivity to error will be greater, control responsiveness will have to be faster and more accurate. But one thing is certain: there will always be space



missions ending with atmospheric flight to a landing point. So workable solutions to the re-entry flight control problem will have to be found for all such missions.

## BIBLIOGRAPHY

1. Lorell, J.: Forces Produced by Fuel Oscillations, Report 20-149, Jet Propulsion Laboratory, Pasadena, Calif.; Oct. 1951.
2. Kalman, R.E.: "A New Approach to Linear Filtering and Prediction Problems," Transactions of the ASME, Journal of Basic Engineering; March 1960.
3. Schaefer, R.A.: "A New Pulse Modulator for Accurate D.C. Amplification with Linear or Nonlinear Devices," IRE Transactions on Instrumentation, Vol. I-11, No. 2; Sept. 1962.
4. Chilton, R.G.: Apollo Spacecraft Control Systems, Presented at IFAC Symposium on Automatic Control in the Peaceful Uses of Space, Stavanger, Norway; June 1965.
5. Lickly, D.J., Morth, H.R., and Crawford, B.S.: Apollo Reentry Guidance, Report R-415, MIT Instrumentation Laboratory, Cambridge, Mass.; July 1963.
6. Crawford, B.S.: Optimization of Reentry "Up-Phase" Guidance, Space Guidance Analysis Memo #35-64, MIT Instrumentation Laboratory, Cambridge, Mass.; Sept. 1964.
7. Rosenbaum, R.: Longitudinal Range Control for a Lifting Vehicle Entering a Planetary Atmosphere, ARS Paper 1911-61; August 1961.

R-500

DISTRIBUTION LIST

Internal

|                       |                        |                        |
|-----------------------|------------------------|------------------------|
| M. Adams              | W. Heintz              | J. Rhode               |
| J. Arnow (Lincoln)    | E. Hickey              | K. Samuelian           |
| R. Battin             | D. Hoag                | P. Sarmanian           |
| E. Berk               | F. Houston             | G. Schmidt             |
| P. Bowditch           | L. B. Johnson          | W. Schmidt             |
| A. Boyce              | M. Johnston            | R. Scholten            |
| R. Boyd               | B. Katz                | E. Schwarm             |
| R. Byers (30)         | A. Koso                | J. Sciegienny          |
| G. Cherry             | M. Kramer              | N. Sears               |
| N. Cluett             | W. Kupfer              | J. Shillingford        |
| E. Capps              | A. Laats               | W. Shotwell (MIT/ACSP) |
| R. Crisp              | D. Ladd                | T. Shuck               |
| W. Crocker            | J. Larsen              | J. Sitomer             |
| G. Cushman            | L. Larson              | W. Stameris            |
| J. Dahlen             | J. Lawrence (MIT/GAEC) | J. Stone               |
| E. Duggan             | T. J. Lawton           | J. Suomala             |
| J. Dunbar             | T. M. Lawton (MIT/MSC) | W. Tanner              |
| K. Dunipace (MIT/KSC) | D. Lickly              | R. Therrien            |
| R. Euvrard            | R. Magee               | W. Toth                |
| J. B. Feldman         | G. Mayo                | M. Trageser            |
| P. Felleman           | J. McNeil              | W. Vander Velde        |
| S. Felix (MIT/S&ID)   | R. McKern              | R. Weatherbee          |
| J. Flanders           | R. Mudgett             | R. White               |
| J. Fleming            | James Miller           | L. Wilk                |
| L. Gediman            | John Miller            | M. Wolff               |
| F. Grant              | J. Nevins              | R. Woodbury            |
| D. Grieff             | J. Nugent              | W. Wrigley             |
| Eldon Hall            | E. Olsson              | D. Yankovich           |
| I. Halzel             | W. Patterson           | Apollo Library (30)    |
|                       | M. Peterson            | MIT/IL Library (10)    |

External:

P. Ebersole (NASA/MSC) (2)  
W. Rhine (NASA/RASPO) (2)  
L. Holdridge (NAA/MIT) (1)  
T. Heuermann (GAEC/MIT) (1)  
AC Spark Plug (10)  
Kollsman (10)  
Raytheon (10)  
Major W. Delaney (AFSC/MIT) (1)  
GAEC: (1)

Grumman Aircraft Engineering Corporation  
Bethpage, Long Island, New York  
Attn: Mr. A. Whitaker

NAA: (1R)

North American Aviation, Inc.  
Space and Information Systems Division  
12214 Lakewood Boulevard  
Downey, California  
Attn: Apollo Data Requirements AE99  
Dept. 41-096-704

Mr. H. Peterson (1)  
Bureau of Naval Weapons  
c/o Raytheon Company  
Foundry Avenue  
Waltham, Massachusetts

Queens Material Quality Section (1)  
c/o Kollsman Instrument Corporation  
Building A 80-08 45th Avenue  
Elmhurst, New York 11373  
Attn: Mr. S. Schwartz

Mr. H. Anschuetz (1)  
USAF Contract Management District  
AC Spark Plug Division of General Motors  
Milwaukee 1, Wisconsin 53201