

MODULAR ELECTRONICS LEARNING (MODEL) PROJECT



OVERCURRENT PROTECTION RELAYS

© 2018-2024 BY TONY R. KUPHALDT – UNDER THE TERMS AND CONDITIONS OF THE
CREATIVE COMMONS ATTRIBUTION 4.0 INTERNATIONAL PUBLIC LICENSE

LAST UPDATE = 5 DECEMBER 2024

This is a copyrighted work, but licensed under the Creative Commons Attribution 4.0 International Public License. A copy of this license is found in the last Appendix of this document. Alternatively, you may visit <http://creativecommons.org/licenses/by/4.0/> or send a letter to Creative Commons: 171 Second Street, Suite 300, San Francisco, California, 94105, USA. The terms and conditions of this license allow for free copying, distribution, and/or modification of all licensed works by the general public.

Contents

1	Introduction	3
1.1	Recommendations for students	3
1.2	Challenging concepts related to overcurrent protective relays	5
1.3	Recommendations for instructors	6
2	Tutorial	7
2.1	Instantaneous- versus time-overcurrent protection	8
2.2	Instantaneous relay construction	10
2.3	Induction disk relay construction	12
2.4	Induction disk relay setting	15
2.5	Inverse time curves	16
2.6	Overcurrent relay calibration	18
2.6.1	Instantaneous relay calibration	18
2.6.2	Inverse time relay calibration	19
3	Historical References	21
3.1	Early overcurrent relays	22
4	Questions	27
4.1	Conceptual reasoning	31
4.1.1	Reading outline and reflections	32
4.1.2	Foundational concepts	33
4.1.3	General Electric IAC77 relay	35
4.1.4	Westinghouse CO-11 relay connections	36
4.1.5	Fast bus trip scheme	37
4.2	Quantitative reasoning	39
4.2.1	Miscellaneous physical constants	40
4.2.2	Introduction to spreadsheets	41
4.2.3	Motor protection	44
4.2.4	Three-phase 50/51 protection circuit	45
4.2.5	Time dial setting	46
4.2.6	Relay voltage drop	47
4.2.7	Trip time simulation program	48
4.3	Diagnostic reasoning	49

<i>CONTENTS</i>	1
4.3.1 Faulted 50/51 system	50
4.3.2 Feeder protection system	51
A Problem-Solving Strategies	53
B Instructional philosophy	55
C Tools used	61
D Creative Commons License	65
E References	73
F Version history	75
Index	76

Chapter 1

Introduction

1.1 Recommendations for students

Fuses were the earliest form of overcurrent protection in electric power systems, and they still fulfill this protective function remarkably well. However, very early in the development of electric power systems the shortcomings of fuses were recognized and the first overcurrent protective relays were developed as an answer to the challenges of fuses. This module focuses on the design and function of overcurrent protection relays.

Important concepts related to overcurrent relays include **pick-up**, **current transformers**, **Joule’s Law**, **Lenz’s Law**, **seal-in**, **normally-open** versus **normally-closed** switch contacts, and **calibration**.

Here are some good questions to ask of yourself while studying this subject:

- How might an experiment be designed and conducted to test the tripping time of an overcurrent relay? What hypothesis (i.e. prediction) might you pose for that experiment, and what result(s) would either support or disprove that hypothesis?
- How does an electromechanical 50 relay function?
- How does an electromechanical 51 relay function?
- Why is an induction disk used as the central mechanism of an electromechanical 51 relay?
- What does the “pick-up” current value represent for a 50 relay?
- What does the “pick-up” current value represent for a 51 relay?
- What function does the drag magnet serve in an electromechanical 51 relay?
- Why is there a seal-in contact included in overcurrent relays?
- How is the relay’s seal-in function interrupted after a trip event?

- What do the different types of “inverse” curve represent for the operation of an overcurrent relay?
- How does one calibrate a 50 relay?
- How does one calibrate a 51 relay?

1.2 Challenging concepts related to overcurrent protective relays

The following list cites concepts related to this module's topic that are easily misunderstood, along with suggestions for properly understanding them:

- **Interpreting single-line diagrams** – a common form of technical documentation in the electrical power industry is the *single-line* or *one-line* diagram, which shows interconnected power system components with lines representing flow-paths of electrical power rather than lines representing individual conductors defining the flow-paths of electric current. To anyone familiar with schematic diagrams, single-line diagrams can seem confusing because one tries to look for current return paths where none are documented. Single-line diagrams should be viewed as though they were *pipng* diagrams showing the flow of some fluid from sources to drains, the fluid in question being electrical energy.
- **Inverse-time protection** – instantaneous overcurrent protection is simple to understand: the relay “picks up” if ever current exceeds a pre-set limit. Inverse-time overcurrent protection, however, is based on the principle of heat build-up in an electrical machine which is fundamentally an accumulation of energy over time: literally the time-integral of electrical power ($\int P dt$). What this means in a practical sense is that the time-delay offered by an overcurrent protection relay is inversely proportional to how severe the overcurrent event is, with higher levels of overcurrent demanding a shorter time-to-trip. This expresses itself in the classic shape of a fuse curve, because fuses are thermal devices which require time to accumulate thermal energy to the point where they melt open and break the circuit.

1.3 Recommendations for instructors

This section lists realistic student learning outcomes supported by the content of the module as well as suggested means of assessing (measuring) student learning. The outcomes state what learners should be able to do, and the assessments are specific challenges to prove students have learned.

- **Outcome** – Demonstrate effective technical reading and writing
Assessment – Students present their outlines of this module’s instructional chapters (e.g. Case Tutorial, Tutorial, Historical References, etc.) ideally as an entry to a larger Journal document chronicling their learning. These outlines should exhibit good-faith effort at summarizing major concepts explained in the text.
- **Outcome** – Apply foundational circuit concepts to the analysis of instrument transformer circuits
Assessment – Calculate secondary voltage for a CT circuit given turns ratios, impedances, and three-phase circuit parameters; e.g. pose problems in the form of the “Relay voltage drop” Quantitative Reasoning question.
- **Outcome** – Properly connect instrument transformers to protective relays
Assessment – Sketch wire connections necessary to properly connect current transformers to overcurrent relays; e.g. pose problems in the form of the “General Electric IAC77 relay” and “Westinghouse CO-11 relay connections” Conceptual Reasoning questions.
- **Outcome** – Independent research
Assessment – Locate overcurrent protective relay datasheets and properly interpret some of the information contained in those documents including inverse-time curves, current ratings, ANSI/IEEE protective functions, etc.

Chapter 2

Tutorial

2.1 Instantaneous- versus time-overcurrent protection

Perhaps the most basic and necessary protective relay function is *overcurrent*: commanding a circuit breaker to trip when the line current becomes excessive. The purpose of overcurrent protection is to guard against power distribution equipment damage, due to the fact that excessive current in a power system dissipates excessive heat in the metal conductors comprising that system. Overcurrent protection is also applied to machines such as motors and generators for the exact same reason: electric current dissipates heat in the windings' resistance ($P = I^2R$), and excessive heat will damage those winding conductors.

Instantaneous overcurrent protection is where a protective relay initiates a breaker trip based on current exceeding a pre-programmed “pickup” value for *any* length of time. This is the simplest form of overcurrent protection, both in concept and in implementation (relay design). In small, self-tripping circuit breakers, this type of protection is best modeled by “magnetic” breakers where the tripping mechanism is actuated by the magnetic field strength of the line conductors: any amount of current greater than the tripping threshold will cause the mechanism to unlatch and open the breaker. In protective relay-based systems, the instantaneous overcurrent protection function is designated by the ANSI/IEEE number code 50.

A primitive instantaneous current relay may be seen in this schematic diagram, taken from page 17 of Victor Todd's book *Protective Relays – their theory, design, and practical operation* published in 1922:

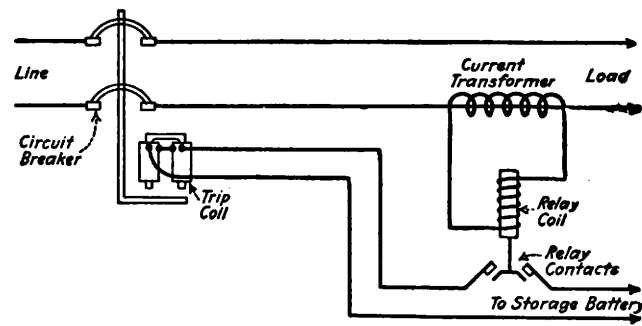

Time overcurrent protection is where a protective relay initiates a breaker trip based on the combination of overcurrent magnitude and duration, the relay tripping sooner with greater current. This is a more sophisticated form of overcurrent protection than instantaneous, expressed as a “time curve” relating overcurrent magnitude to trip time. In small, self-tripping circuit breakers, this type of protection is realized by “thermal” tripping mechanisms actuated by the force of a bimetallic strip heated by line current: excessive current heats the metal strip, which then forces the mechanism to unlatch and open the breaker. In protective relay-based systems, the time overcurrent protection function is designated by the ANSI/IEEE number code *51*. Time overcurrent protection allows for significant overcurrent magnitudes, so long as these overcurrent events are brief enough that the power equipment avoids heat damage.

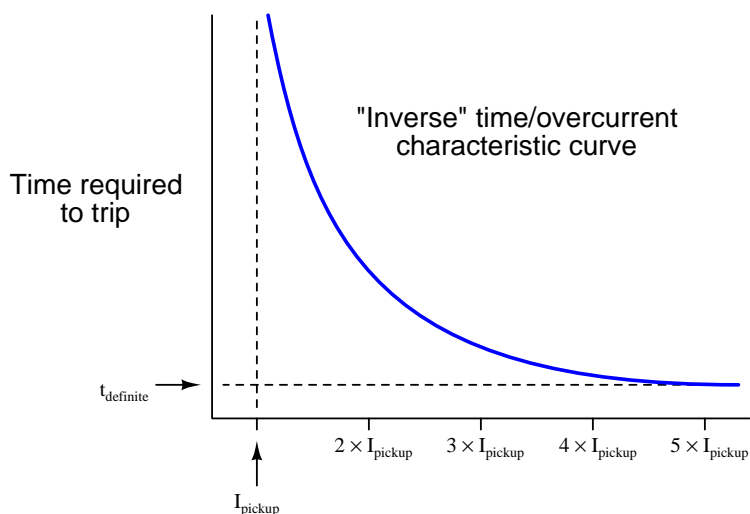

An obvious feature of this graph is that relay tripping time is inversely proportional to fault current magnitude: the greater the fault, the faster the relay will trip. This is why it is called an *inverse time* relay. Not all inverse time relays exhibit the same curve, though, with some being “flatter” and others being “sharper” in order to provide more or less tripping time for a given magnitude of overcurrent.

An important feature of any practical time-overcurrent relay is a certain *minimum* trip time, called the *definite time*¹. This feature becomes important when multiple overcurrent relays are applied along the length of a distribution line, and the tripping times of those relays must be “coordinated” so that the upstream relay closest to the fault will be the first to trip and thereby isolate as little of the system as necessary to clear the fault. One can imagine a scenario where several overcurrent relays along one line trip simultaneously because the large magnitude of the fault current causes all their tripping times to be equally brief. With individually settable minimum (“definite”) time values, proper tripping order can always be ensured regardless of fault magnitude.

¹There is such a thing as a time-overcurrent relay that *only* implements a definite time, akin to an instantaneous overcurrent relay with a moderate pick-up value (rather than a very large pick-up value) combined with a fixed time-delay function. However, it is far more common in modern practice to encounter time-overcurrent relays having an inherent inverse response function combined with a definite (minimum) trip time.

2.2 Instantaneous relay construction

Electromechanical 50 (instantaneous overcurrent) relays are models of simplicity, consisting of nothing more than a coil², armature, and contact assembly (a “relay” in the general electrical/electronic sense of the word). Spring tension holds the trip contacts open, but if the magnetic field developed by the CT secondary current becomes strong enough to overcome the spring’s tension, the contacts close, commanding the circuit breaker to trip:

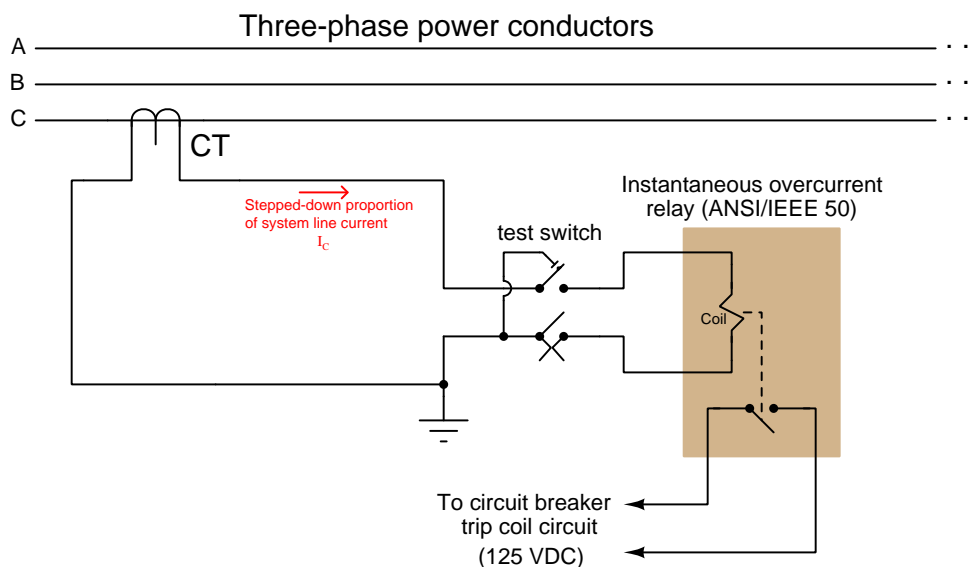

The protective relay circuit in the above diagram is for one phase of the three-phase power system only. In practice, three different protective relay circuits (three CTs, and three 50 relays with their trip contacts wired in parallel) would be connected together to the circuit breaker’s trip coil, so that the breaker will trip if *any* of the 50 relays detect an instantaneous overcurrent condition. The monitoring of all three line currents is necessary because power line faults are usually unbalanced: one line will see a much greater share of the fault current than the other lines. A single 50 relay sensing current on a single line would not provide adequate instantaneous overcurrent protection for all three lines.

The amount of CT secondary current necessary to activate the 50 relay is called the *pickup current*, so named because these legacy instantaneous overcurrent relays used gravity to establish the relay contact’s “open” resting state (down), their armatures literally being *picked up* into the closed position by the application of sufficient current. Its value may be varied by adjusting a movable ferromagnetic core inside the coil’s center: inserting the core deeper inside the coil enhances the

²In protective relay circuit diagrams, it is conventional to show relay coils as “zig-zag” symbols rather than as actual coils of wire as is customary in electronic schematics. Those familiar with “ladder” style electrical wiring diagrams may recognize this as the symbol for a *solenoid* coil. Once again, we see here the context-dependence of symbols and diagram types: a component type may have multiple symbols depending on which type of diagram it’s represented in, while a common symbol may have different meanings in different diagrams.

magnetic field, resulting in a smaller pickup value; retracting the core weakens the magnetic field and raises the pickup value.

In the following photographs we see the instantaneous relay element of a General Electric model IAC overcurrent relay, consisting of a simple gravity-restrained SPST relay. When this element “picks up” from sufficient current passed through its coil, the armature rises up to close the normally-open SPST contact and also actuates an orange-colored “target” flag that latches in place to indicate the occurrence of an instantaneous overcurrent trip event (as shown in the right-hand photo when my finger presses up on the relay’s armature):

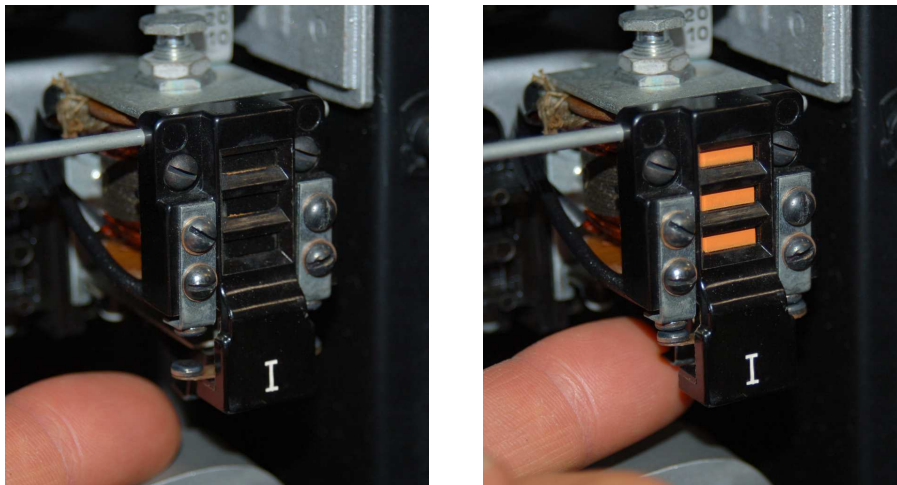

This relay’s movable ferromagnetic core takes the form of a fine-pitched bolt on top of the unit that may be turned to achieve varying pick-up current values. A crude scale showing 10 and 20 Amperes of pick-up is visible behind the bolt’s head, with 10 Amperes representing a bolt position farther-inserted into the relay’s core than the 20 Ampere position.

2.3 Induction disk relay construction

Electromechanical 51 (time overcurrent) relays are more complicated in design, using a rotating metal “induction disk” to physically time the overcurrent event, and trip the circuit breaker only if the overcurrent condition persists long enough. A photograph of a General Electric time-overcurrent induction-disk relay appears here:

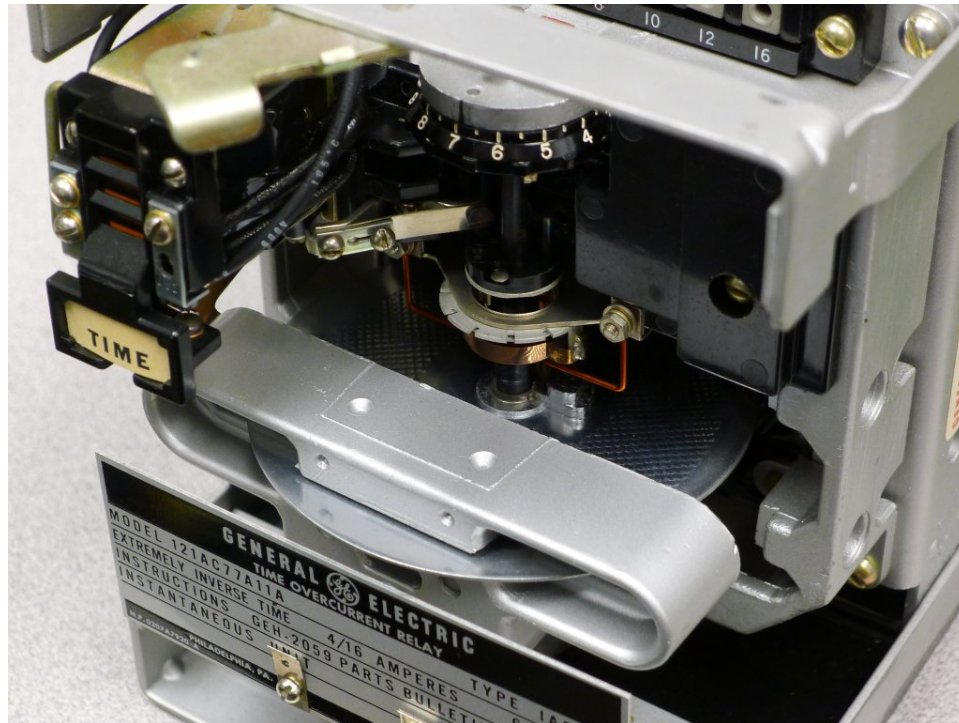

The round disk you see in the photograph receives a torque from an electromagnet coil assembly acting like the stator coils of an induction motor: alternating current passing through these coils cause alternating magnetic fields to develop through the rear section of the disk, inducing currents in the aluminum disk, generating a “motor” torque on the disk to rotate it clockwise (as seen from the vantage point of the camera in the above photo). A spiral spring applies a counter-clockwise restraining torque to the disk’s shaft. The pickup value for the induction disk (i.e. the minimum amount of CT current necessary to overcome the spring’s torque and begin to rotate the disk) is established by the spring tension and the stator coil field strength. If the CT current exceeds the pickup value for a long enough time, the disk rotates until it closes a normally-open contact to send 125 Volt DC power to the circuit breaker’s trip coil.

A silver-colored permanent magnet assembly at the front of the disk provides a consistent “drag” force opposing disk rotation. As the aluminum disk rotates through the permanent magnet’s field, eddy currents induced in the disk set up their own magnetic poles to oppose the disk’s motion (Lenz’s Law). The effect is akin to having the disk rotate through a viscous liquid, and it is this dynamic retarding force that provides a repeatable, inverse time delay.

A set of three photographs show the motion of a peg mounted on the induction disk as it approaches the stationary trip contact. From left to right we see the disk in the resting position, partially rotated, and fully rotated:

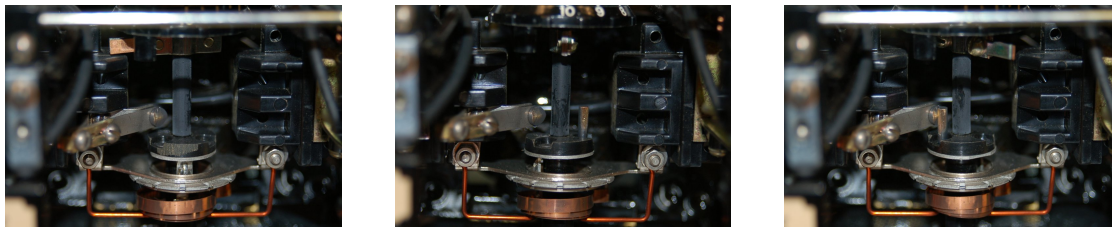

The mechanical force actuating the time-overcurrent contact is not nearly as strong as the force actuating the instantaneous overcurrent contact. The peg may only lightly touch the stationary contact when it reaches its final position, failing to provide a secure and lasting electrical contact when needed. For this reason, a *seal-in relay* actuated by current in the 125 VDC trip circuit is provided to maintain firm electrical contact closure in parallel with the rotating peg contact. This “seal-in” contact ensures a reliable circuit breaker trip even if the peg momentarily brushes or bounces against the stationary contact. The parallel seal-in contact also helps reduce arcing at the peg’s contact by carrying most of the trip coil current.

A simplified diagram of an induction disk time-overcurrent relay is shown in the following diagram, for one phase of the three-phase power system only. In practice, three different protective relay circuits (three CTs, and three 51 relays with their trip contacts wired in parallel) would be connected together to the circuit breaker's trip coil, so that the breaker will trip if *any* of the 51 relays detect a timed overcurrent condition:

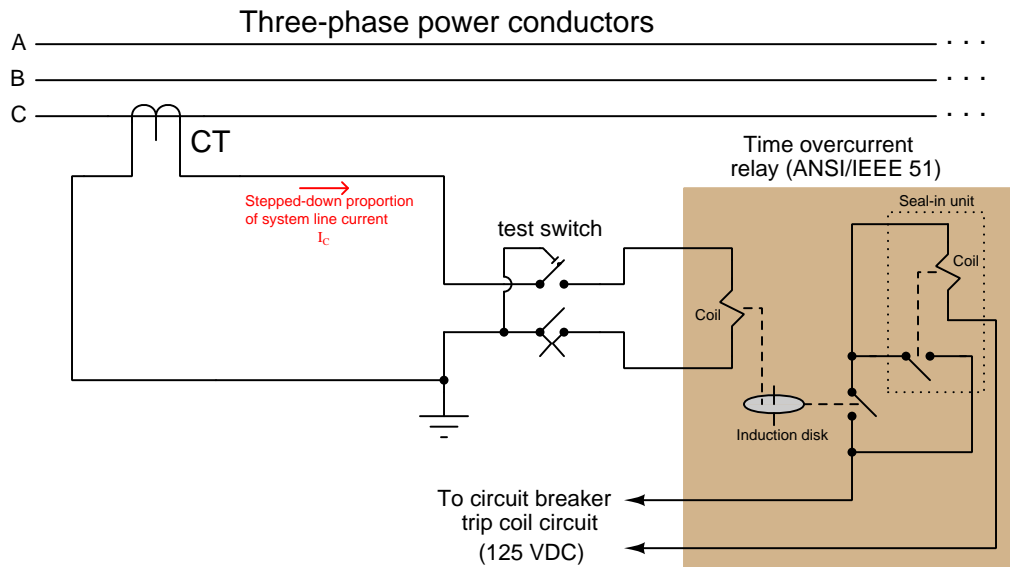

The seal-in unit is shown as an electromechanical relay connected with its contact in parallel with the induction disk contact, but with its actuating coil connected in series to sense the current in the 125 VDC trip circuit. Once the induction disk contact closes to initiate current in the DC trip circuit, even momentarily, the seal-in coil will energize which closes the seal-in contact and ensures the continuance of DC trip current to the circuit breaker's trip coil. The relay's seal-in function will subsequently maintain the trip command until some external contact opens to break the trip circuit, usually an auxiliary contact within the circuit breaker itself (e.g. the 52a contact).

2.4 Induction disk relay setting

Setting a time overcurrent (51) relay consists of establishing the value of current necessary to overcome the restraining spring's torque. Any current value less than this pickup value cannot ever cause the relay to trip. In induction disk relays such as the General Electric model shown here, this pickup setting may be coarsely adjusted by connecting a movable wire to one of several *taps* on a transformer coil inside the relay, varying the ratio of CT current sent to the induction disk stator coils. Each tap is labeled with the number of whole amperes (AC) delivered by the secondary winding of the CT required for relay pick-up³ (e.g. a tap value of “5” means that approximately 5 Amperes of CT secondary current is required for induction disk pickup). A fine adjustment is provided in the form of a variable resistor in series with the stator coils.

A photograph of the tap wire setting (coarse pickup adjustment) and resistor (fine pickup adjustment) are shown here. The tap in this first photograph happens to be set at the 4 Ampere position, which means the CT secondary current must exceed 4 Amperes AC in order to cause the disk to advance toward closing the trip contact:

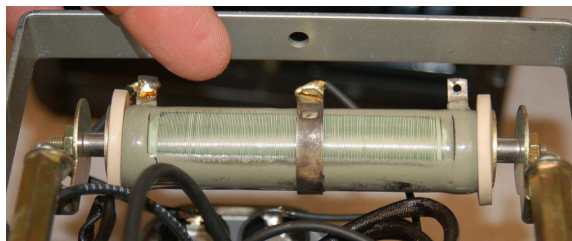
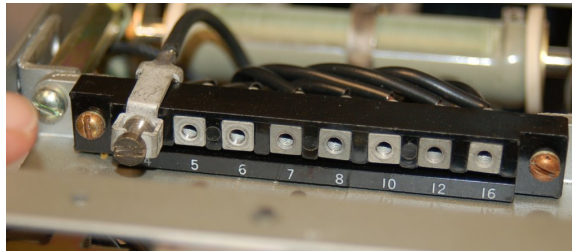

Proper setting of the time-overcurrent pickup value is determined by the maximum continuous current rating of the system being protected and the ratio of the current transformer (CT) used to sense that current. No ordinary amount of line current should result in the relay “picking up” and timing towards a trip – only a true overload condition should cause that to occur.

³Note that this General Electric relay provides pickup tap settings well in excess of 5 Amperes, which is the nominal full-load rating of most current transformers. CTs rated for protective relay applications are fully capable of exceeding their normal full-load capacity for short time periods, which is a necessary feature due to the extreme nature of fault current conditions. It is not uncommon for fault currents in a power system to exceed full-load current conditions by a factor of 20!

After the proper pickup value has been set, the time value is established by rotating a small wheel called the *time dial* located above the induction disk. This wheel functions as an adjustable stop for the induction disk's motion, positioning the disk closer to or farther away from the trip contact in its resting condition:

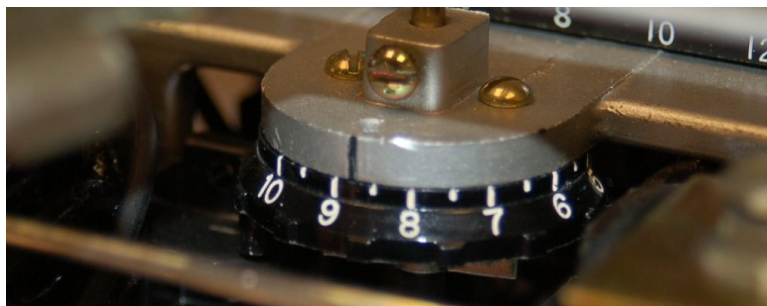

The amount of disk rotation necessary to close the trip contact may be set by adjusting the position of this time dial: a low number on the time dial (e.g. 1) means the disk need only rotate a small amount to close the contact; a high number on the time dial (e.g. 10) sets the resting position farther away from contact, so that the disk must rotate farther to trip. These time dial values are linear multipliers: a time dial setting of 10, for example, exhibits twice the time to trip than a setting of 5, for any given overload condition.

2.5 Inverse time curves

Several different curve shapes are commonly applied in overcurrent protection applications within the United States:

- Moderately inverse
- Inverse
- Very inverse
- Extremely inverse
- Short-time inverse

Time curves standardized by the Swiss standards agency IEC (International Electrotechnical Commission) include:

- Standard inverse
- Very inverse
- Extremely inverse
- Long-time inverse
- Short-time inverse

The purpose for having different curves in time-overcurrent relays is related to a concept called *coordination*, where the 51 relay is just one of multiple overcurrent protection devices in a power system. Other overcurrent protection devices include fuses and additional 51 relays at different locations along the same line. Ideally, only the device closest to the fault will trip, allowing power to be maintained at all “upstream” locations. This means we want overcurrent protection devices at the remote end(s) of a power system to be more sensitive and to trip faster than devices closer to the source, where a trip would mean an interruption of power to a greater number of loads.

Legacy electromechanical time-overcurrent (51) relays implemented these different inverse curve functions by using induction disks with different “cam” shapes⁴. Modern microprocessor-based 51 relays contain multiple curve functions as mathematical formulae stored within read-only memory (ROM), and as such may be programmed to implement any curve desired. It is an amusing anachronism that even in digital 51 relays containing no electromagnets or induction disks, you will find parameters labeled “pickup” and “time dial” in honor of legacy electromechanical relay behavior.

The trip time formulae programmed within a Schweitzer Engineering Laboratories model SEL-551 overcurrent relay for inverse, very inverse, and extremely inverse (US) time functions are given here:

$$t = T \left(0.18 + \frac{5.95}{M^2 - 1} \right) \quad \text{Inverse curve}$$

$$t = T \left(0.0963 + \frac{3.88}{M^2 - 1} \right) \quad \text{Very inverse curve}$$

$$t = T \left(0.0352 + \frac{5.67}{M^2 - 1} \right) \quad \text{Extremely inverse curve}$$

Where,

t = Trip time (seconds)

T = Time Dial setting (typically 0.5 to 15)

M = Multiples of pickup current (e.g. if $I_{pickup} = 4.5$ A, a 9.0 A signal would be $M = 2$)

⁴If you examine the induction disk from a 51 relay, you will note that the disk’s radius is not constant, and that there is actually a “step” along the circumference of the disk where its radius transitions from minimum to maximum. The amount of disk material exposed to the stator coil’s magnetic field to generate operating torque therefore changes with rotation angle, providing a nonlinear function altering the shape of the relay’s timing curve.

2.6 Overcurrent relay calibration

Modern digital overcurrent relays rarely require calibration, because the analog-to-digital converter circuits responsible for converting the CT current signals into digital number values readable by the relay's microprocessor are highly reliable and unlikely to "drift" with age. Electromechanical overcurrent relays, however, with their moving parts, bearings, drag magnets, and other components liable to wear must be periodically calibrated to ensure accurate operation. What follows in this section is a brief description of calibration principles, and should never be used as a substitute for closely reading and abiding by the relay manufacturer's service procedures.

First, you will need to use a *relay test set* to generate AC currents large enough to drive the relay's functions to trip, and to serve as a timer to measure the amount of time between the application of the test current and the trip contact closure. Crude testing may be done with home-made equipment⁵, but a good-quality relay test set will be far more accurate.

2.6.1 Instantaneous relay calibration

Instantaneous overcurrent relays are typically adjusted by threading a ferromagnetic core into or out of the center of the relay's solenoid coil. It is common for relays of this type to provide a scale showing approximate pickup current value as a function of core position, but these scales are approximate only. The only confident way to certify the accuracy of this relay type is to test it with simulated fault current values to verify when it actually picks up.

A word of caution is in order here: since the pickup values for an instantaneous overcurrent relay are typically quite high (e.g. 15 Amperes for a standard 5-Ampere output CT circuit), testing with this amount of current even for just a few seconds' worth of time will cause the relay's wire coil to heat up, which will in turn disturb the accuracy of the relay. For this reason, one should never apply large amounts of test current to the relay for more than fractions of a second unless absolutely necessary! The purpose of an instantaneous overcurrent relay is to trip *immediately* when current exceeds the pickup value, and so a very brief application of current is all that should be required to check its calibration: set the current just below the pickup value and verify the relay *doesn't* trip when energized, then set the current just above the pickup value and verify it *does* trip when energized.

⁵I have used a Variac to send adjustable 120 Volt AC line power to a step-down transformer and then to the relay being tested, and used a hand-held stopwatch to time contact closure, but this yields highly variable results (mostly due to the inaccuracies of human timing). An improvement on this crude scheme is to program a PLC (Programmable Logic Controller) or microcontroller to precisely measure the time between application of current and trip contact closure, but then you still have the Variac's imprecision as a source of error.

2.6.2 Inverse time relay calibration

Induction disk time delay relay calibration requires verification of two distinct parameters: *pickup* value and *time delay*. The pickup value is that amount of current passed through the relay necessary to generate an operating torque equal in magnitude to the restraining torque of the spring. Any current value greater than this pickup value will exceed the restraint spring's torque and cause the disk to advance toward the tripping position. Any current less than or equal to this value can never generate enough torque to close the trip contact. Time delay is a separate parameter, adjusted on the relay by varying the effect of the drag magnet on the induction disk's motion. With time delay properly set, the relay should close its trip contact at a predictable interval following application of overcurrent (i.e. current values in excess of the pickup). At least, this is how an induction disk relay *should* behave, and calibration ensures this behavior.

In the General Electric relay design, pickup value is adjusted coarsely by the tap setting and finely by the variable resistor value⁶. Small movements of the induction disk are difficult to visually perceive, and so we need some means to detect when the disk is holding position (i.e. when operating torque equals restraint spring torque) to verify pickup current. A good way to do this is to gently rotate the disk by hand until the trip contact closes, using a multimeter set for continuity measurement to indicate closure of this contact. If the test current is precisely equal to the pickup value, the multimeter should register intermittent continuity as the contact points barely touch each other. If current rises above the pickup value, a firm indication of continuity will result; if current falls below pickup, continuity will cease.

Only after the relay's pickup value has been accurately set will the relay be ready for testing its time delay. For this, one must apply current in excess of the pickup value (generally, some integer multiple of pickup current, like 2× or 3×) and use an accurate timing instrument to measure how long it takes for the disk to turn from its resting position to the trip position.

The General Electric overcurrent relay makes timing adjustable by positioning the drag magnet at different positions along the disk's radius. Moving the magnet out away from the center of the disk gives it more leverage and exposes it to a faster disk surface velocity, both effects causing the disk to experience more braking torque and thereby lengthening the tripping time. Moving the magnet in toward the disk's axis weakens its effect and causes the disk to rotate more rapidly for any given current, thus shortening the tripping time.

Timing calibration must be performed at multiple values of current exceeding the pickup value, in order to ensure the relay trips within the right amount of time for each of those current values. This is due to the fact that inverse-time functions are *curves*, and more than two points are necessary to define any curve.

⁶The restraint spring may also be adjusted, but this is generally unnecessary.

Chapter 3

Historical References

This chapter is where you will find references to historical texts and technologies related to the module's topic.

Readers may wonder why historical references might be included in any modern lesson on a subject. Why dwell on old ideas and obsolete technologies? One answer to this question is that the initial discoveries and early applications of scientific principles typically present those principles in forms that are unusually easy to grasp. Anyone who first discovers a new principle must necessarily do so from a perspective of ignorance (i.e. if you truly *discover* something yourself, it means you must have come to that discovery with no prior knowledge of it and no hints from others knowledgeable in it), and in so doing the discoverer lacks any hindsight or advantage that might have otherwise come from a more advanced perspective. Thus, discoverers are forced to think and express themselves in less-advanced terms, and this often makes their explanations more readily accessible to others who, like the discoverer, comes to this idea with no prior knowledge. Furthermore, early discoverers often faced the daunting challenge of explaining their new and complex ideas to a naturally skeptical scientific community, and this pressure incentivized clear and compelling communication. As James Clerk Maxwell eloquently stated in the Preface to his book *A Treatise on Electricity and Magnetism* written in 1873,

It is of great advantage to the student of any subject to read the original memoirs on that subject, for science is always most completely assimilated when it is in its nascent state . . . [page xi]

Furthermore, grasping the historical context of technological discoveries is important for understanding how science intersects with culture and civilization, which is ever important because new discoveries and new applications of existing discoveries will always continue to impact our lives. One will often find themselves impressed by the ingenuity of previous generations, and by the high degree of refinement to which now-obsolete technologies were once raised. There is much to learn and much inspiration to be drawn from the technological past, and to the inquisitive mind these historical references are treasures waiting to be (re)-discovered.

3.1 Early overcurrent relays

A fascinating historical reference on protective relay systems is Victor Todd's *Protective Relays – their theory, design, and practical operation* published in 1922. One notable detail in this book is just how closely some of the electromagnetic relay models circa 1922 resemble modern electromechanical protective relays.

In the following image taken from page 67, we see both a simplified diagram and a photograph of a Westinghouse model CO¹ time-overcurrent relay:

INDUCTION-TYPE CURRENT RELAYS 67

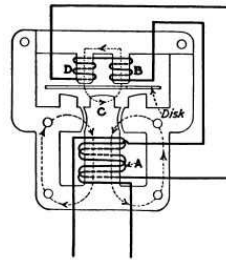

FIG. 78.—Magnetic and electric circuit of Westinghouse inverse-time-limit induction type relay.

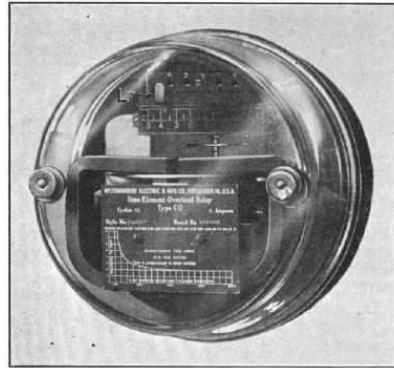
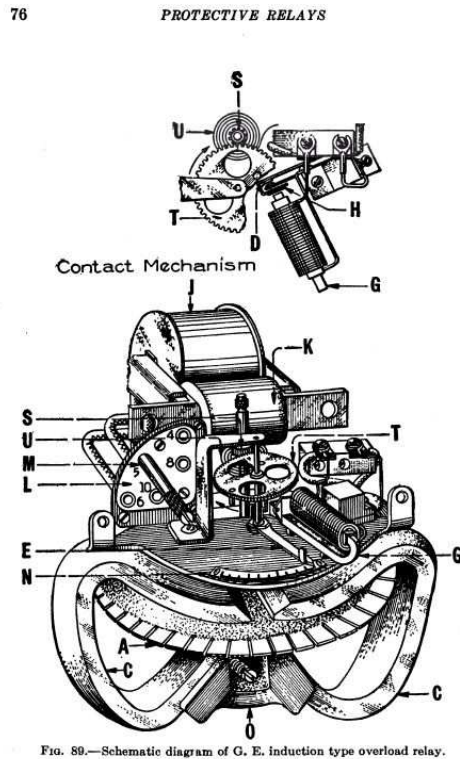

FIG. 79.—Westinghouse induction type overload relay.

Note how the model CO relay of that era provided a helpful trip time curve on its face, in plain site of the user for convenient reference.

¹It is worth noting that you can still purchase Westinghouse model CO relays at the time of this writing (2018), and that a great many are still in use. They look a bit different from the one shown here from 1922, but not *that* different!

Another photograph on page 76 shows an internal sketch of a General Electric induction-disk time-overcurrent relay:



Instead of a *time dial* as found on modern versions of this overcurrent relay, we see here a *time lever* (component “E” in the illustration) fulfilling the same function: providing an adjustable point of rest for the rotating disk.

Page 80 shows a close-up photograph of the same General Electric time-overcurrent relay:

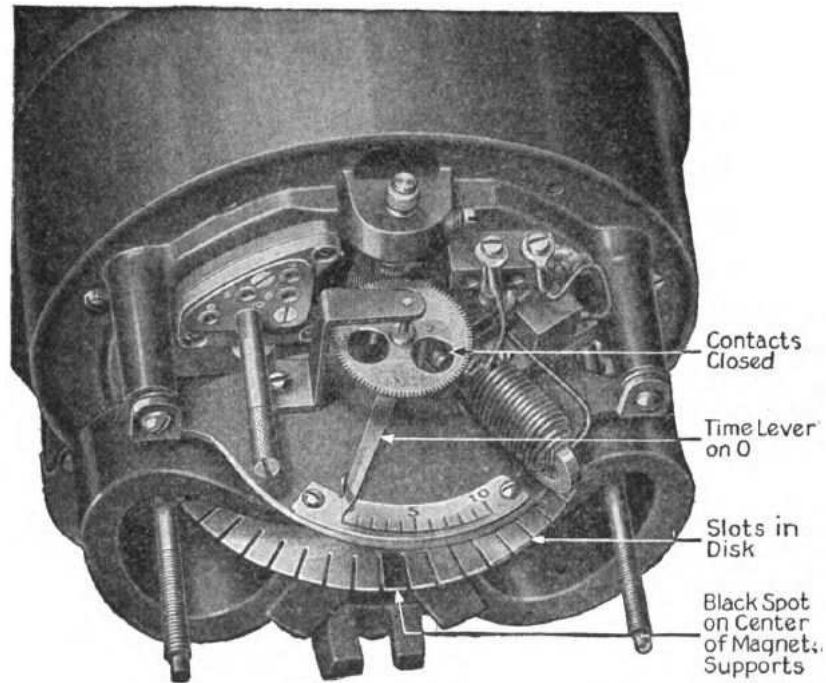

FIG. 93.—Showing the correct relation between contacts, time lever and black disk spot in the G. E. induction overload relay.

Here we also see selectable current “taps” just as on the more modern GE induction disk relays where the user may select the desired pick-up current value.

A few quotes from Todd's book describe time-delayed overcurrent relay technology of the day and their various shortcomings.

On page 23 the author outlines a few methods by which electromechanical overcurrent relays may be delayed in their action:

How Time Delays Are Obtained. – The method of lagging or damping the moving element of a protective relay depends largely on the principle of operation of the relay. In the direct-current type employing a moving coil and permanent or electro-magnet, the time delay is obtained by the use of an aluminum or copper bobbin which also serves as a support for the winding. It takes power to move the bobbin through the intense field and thus the movement, and consequently the time delay, is inversely proportional to the power applied, or in other words, to the overload.

In the solenoid and plunger type, some manufacturers employ a leather bellows with a small adjustable needle valve to allow the air to escape slowly. As the plunger attempts to rise, the air is compressed in the bellows, thus retarding the movement. Other manufacturers use a dashpot with oil to retard the motion.

In the induction type, an aluminum disk rotates between strong permanent magnets which retard the motion. In this type, the definite time is obtained by having a small transformer which saturates on heavy overload, thus limiting the power which is supplied to the relay windings.

Other types use various novel methods which will be fully described under the various types of protective relays.

[page 23]

On page 29 the author describes shortcomings of the leather bellows mechanism, which modern readers will find somewhat amusing:

The greatest objection to the bellows-type relay is that the leather, unless carefully attended to, will dry out and crack, making the permanence of time setting very unreliable. To secure the best operation the bellows should be rubbed with neatsfoot² oil every few months, and load-time curves taken. Otherwise the relays may fail at a critical time. [page 29]

²For those unfamiliar with this substance (as was I before reading Todd's book), *neatsfoot* is an animal oil derived from the shin bones and feet of cattle, and it is typically used to condition and preserve natural leather.

On pages 39 and 40 the author describes a time-delay mechanism for a plunger-style overload relay based on a piston moving through oil. Note how even this time-delay technology was prone to operational problems. Letter symbols refer to a diagram of this relay, not shown here:

Instead of forcing air through a needle valve, oil is forced by a piston on its upward travel through the valve *E* and out of hole *F*, Fig. 46. The piston *C* has a number of holes in the bottom, which are normally covered by the disk *D*. Upon upward travel the disk closes the holes practically oiltight, but on downward travel it rises and allows quick resetting of the plunger. [page 39]

These relays cannot be used where they are subjected to extreme changes in temperature, and no other oil except that supplied by the manufacturers should be used in the dashpot. Their time may be varied from almost instantaneous at heavy loads, to over 5 min. at 150 per cent load. [page 40]

Protective relays of that era were subject to a variety of problems unknown to modern users, some due to technological limitations and others due to immature designs for this relatively new (at the time) technical art. As a helpful guide to engineers of the day selecting overcurrent relays for use at their facility, Todd gives the following recommendations:

Relay Specifications. – In order that unreliable and unsatisfactory overload and underload relays may not be used in installations, it is always well to add the following specifications. If a relay meets these fundamental requirements and is well constructed, it should be satisfactory, but these specifications will bar the undesirable relays.

“Overload-protective relays shall be equipped with a time limit that varies inversely with the current at all moderate overloads and which will not drop below a definite minimum time at extreme overloads. The definite time limit shall be adjustable for all values between 0 and 2 seconds (or 0 and 4 sec.) which adjustment shall be accurate and permanent. The relays shall be calibrated at the factory, and the calibrating data shall be fixed to the front of the relay. It shall be possible [page 83]

to make, without the use of any testing equipment or timing devices, independent adjustment of both the time limit and the overload value at which the relay will operate. Relays shall be so constructed that they will not be damaged or their calibration affected by the maximum current that the generating equipment can deliver to them. Their construction shall be such that in case an overload ceases before the relay contacts have been closed, the relay will instantly commence to reset to its starting position. The energy that the current transformer must furnish to operate a relay shall not be in excess of 20 volt-amp.” [page 84]

Chapter 4

Questions

This learning module, along with all others in the ModEL collection, is designed to be used in an inverted instructional environment where students independently read¹ the tutorials and attempt to answer questions on their own *prior* to the instructor's interaction with them. In place of lecture², the instructor engages with students in Socratic-style dialogue, probing and challenging their understanding of the subject matter through inquiry.

Answers are not provided for questions within this chapter, and this is by design. Solved problems may be found in the Tutorial and Derivation chapters, instead. The goal here is *independence*, and this requires students to be challenged in ways where others cannot think for them. Remember that you always have the tools of *experimentation* and *computer simulation* (e.g. SPICE) to explore concepts!

The following lists contain ideas for Socratic-style questions and challenges. Upon inspection, one will notice a strong theme of *metacognition* within these statements: they are designed to foster a regular habit of examining one's own thoughts as a means toward clearer thinking. As such these sample questions are useful both for instructor-led discussions as well as for self-study.

¹Technical reading is an essential academic skill for any technical practitioner to possess for the simple reason that the most comprehensive, accurate, and useful information to be found for developing technical competence is in textual form. Technical careers in general are characterized by the need for continuous learning to remain current with standards and technology, and therefore any technical practitioner who cannot read well is handicapped in their professional development. An excellent resource for educators on improving students' reading prowess through intentional effort and strategy is the book *Reading For Understanding – How Reading Apprenticeship Improves Disciplinary Learning in Secondary and College Classrooms* by Ruth Schoenbach, Cynthia Greenleaf, and Lynn Murphy.

²Lecture is popular as a teaching method because it is easy to implement: any reasonably articulate subject matter expert can talk to students, even with little preparation. However, it is also quite problematic. A good lecture always makes complicated concepts seem easier than they are, which is bad for students because it instills a false sense of confidence in their own understanding; reading and re-articulation requires more cognitive effort and serves to verify comprehension. A culture of teaching-by-lecture fosters a debilitating dependence upon direct personal instruction, whereas the challenges of modern life demand independent and critical thought made possible only by gathering information and perspectives from afar. Information presented in a lecture is ephemeral, easily lost to failures of memory and dictation; text is forever, and may be referenced at any time.

GENERAL CHALLENGES FOLLOWING TUTORIAL READING

- Summarize as much of the text as you can in one paragraph of your own words. A helpful strategy is to explain ideas as you would for an intelligent child: as simple as you can without compromising too much accuracy.
- Simplify a particular section of the text, for example a paragraph or even a single sentence, so as to capture the same fundamental idea in fewer words.
- Where did the text make the most sense to you? What was it about the text's presentation that made it clear?
- Identify where it might be easy for someone to misunderstand the text, and explain why you think it could be confusing.
- Identify any new concept(s) presented in the text, and explain in your own words.
- Identify any familiar concept(s) such as physical laws or principles applied or referenced in the text.
- Devise a proof of concept experiment demonstrating an important principle, physical law, or technical innovation represented in the text.
- Devise an experiment to disprove a plausible misconception.
- Did the text reveal any misconceptions you might have harbored? If so, describe the misconception(s) and the reason(s) why you now know them to be incorrect.
- Describe any useful problem-solving strategies applied in the text.
- Devise a question of your own to challenge a reader's comprehension of the text.

GENERAL FOLLOW-UP CHALLENGES FOR ASSIGNED PROBLEMS

- Identify where any fundamental laws or principles apply to the solution of this problem, especially before applying any mathematical techniques.
- Devise a thought experiment to explore the characteristics of the problem scenario, applying known laws and principles to mentally model its behavior.
- Describe in detail your own strategy for solving this problem. How did you identify and organized the given information? Did you sketch any diagrams to help frame the problem?
- Is there more than one way to solve this problem? Which method seems best to you?
- Show the work you did in solving this problem, even if the solution is incomplete or incorrect.
- What would you say was the most challenging part of this problem, and why was it so?
- Was any important information missing from the problem which you had to research or recall?
- Was there any extraneous information presented within this problem? If so, what was it and why did it not matter?
- Examine someone else's solution to identify where they applied fundamental laws or principles.
- Simplify the problem from its given form and show how to solve this simpler version of it. Examples include eliminating certain variables or conditions, altering values to simpler (usually whole) numbers, applying a limiting case (i.e. altering a variable to some extreme or ultimate value).
- For quantitative problems, identify the real-world meaning of all intermediate calculations: their units of measurement, where they fit into the scenario at hand. Annotate any diagrams or illustrations with these calculated values.
- For quantitative problems, try approaching it qualitatively instead, thinking in terms of “increase” and “decrease” rather than definite values.
- For qualitative problems, try approaching it quantitatively instead, proposing simple numerical values for the variables.
- Were there any assumptions you made while solving this problem? Would your solution change if one of those assumptions were altered?
- Identify where it would be easy for someone to go astray in attempting to solve this problem.
- Formulate your own problem based on what you learned solving this one.

GENERAL FOLLOW-UP CHALLENGES FOR EXPERIMENTS OR PROJECTS

- In what way(s) was this experiment or project easy to complete?
- Identify some of the challenges you faced in completing this experiment or project.

- Show how thorough documentation assisted in the completion of this experiment or project.
- Which fundamental laws or principles are key to this system's function?
- Identify any way(s) in which one might obtain false or otherwise misleading measurements from test equipment in this system.
- What will happen if (component X) fails (open/shorted/etc.)?
- What would have to occur to make this system unsafe?

4.1 Conceptual reasoning

These questions are designed to stimulate your analytic and synthetic thinking³. In a Socratic discussion with your instructor, the goal is for these questions to prompt an extended dialogue where assumptions are revealed, conclusions are tested, and understanding is sharpened. Your instructor may also pose additional questions based on those assigned, in order to further probe and refine your conceptual understanding.

Questions that follow are presented to challenge and probe your understanding of various concepts presented in the tutorial. These questions are intended to serve as a guide for the Socratic dialogue between yourself and the instructor. Your instructor’s task is to ensure you have a sound grasp of these concepts, and the questions contained in this document are merely a means to this end. Your instructor may, at his or her discretion, alter or substitute questions for the benefit of tailoring the discussion to each student’s needs. The only absolute requirement is that each student is challenged and assessed at a level equal to or greater than that represented by the documented questions.

It is far more important that you convey your *reasoning* than it is to simply convey a correct answer. For this reason, you should refrain from researching other information sources to answer questions. What matters here is that *you* are doing the thinking. If the answer is incorrect, your instructor will work with you to correct it through proper reasoning. A correct answer without an adequate explanation of how you derived that answer is unacceptable, as it does not aid the learning or assessment process.

You will note a conspicuous lack of answers given for these conceptual questions. Unlike standard textbooks where answers to every other question are given somewhere toward the back of the book, here in these learning modules students must rely on other means to check their work. The best way by far is to debate the answers with fellow students and also with the instructor during the Socratic dialogue sessions intended to be used with these learning modules. Reasoning through challenging questions with other people is an excellent tool for developing strong reasoning skills.

Another means of checking your conceptual answers, where applicable, is to use circuit simulation software to explore the effects of changes made to circuits. For example, if one of these conceptual questions challenges you to predict the effects of altering some component parameter in a circuit, you may check the validity of your work by simulating that same parameter change within software and seeing if the results agree.

³*Analytical* thinking involves the “disassembly” of an idea into its constituent parts, analogous to dissection. *Synthetic* thinking involves the “assembly” of a new idea comprised of multiple concepts, analogous to construction. Both activities are high-level cognitive skills, extremely important for effective problem-solving, necessitating frequent challenge and regular practice to fully develop.

4.1.1 Reading outline and reflections

“Reading maketh a full man; conference a ready man; and writing an exact man” – Francis Bacon

Francis Bacon’s advice is a blueprint for effective education: reading provides the learner with knowledge, writing focuses the learner’s thoughts, and critical dialogue equips the learner to confidently communicate and apply their learning. Independent acquisition and application of knowledge is a powerful skill, well worth the effort to cultivate. To this end, students should read these educational resources closely, journal their own reflections on the reading, and discuss in detail their findings with classmates and instructor(s). You should be able to do all of the following after reading any instructional text:

☑ Briefly **SUMMARIZE THE TEXT** in the form of a journal entry documenting your learning as you progress through the course of study. Share this summary in dialogue with your classmates and instructor. Journaling is an excellent self-test of thorough reading because you cannot clearly express what you have not read or did not comprehend.

☑ Demonstrate **ACTIVE READING STRATEGIES**, including verbalizing your impressions as you read, simplifying long passages to convey the same ideas using fewer words, annotating text and illustrations with your own interpretations, working through mathematical examples shown in the text, cross-referencing passages with relevant illustrations and/or other passages, identifying problem-solving strategies applied by the author, etc. Technical reading is a special case of problem-solving, and so these strategies work precisely because they help solve any problem: paying attention to your own thoughts (metacognition), eliminating unnecessary complexities, identifying what makes sense, paying close attention to details, drawing connections between separated facts, and noting the successful strategies of others.

☑ Identify **IMPORTANT THEMES**, especially **GENERAL LAWS** and **PRINCIPLES**, expounded in the text and express them in the simplest of terms as though you were teaching an intelligent child. This emphasizes connections between related topics and develops your ability to communicate complex ideas to anyone.

☑ Form **YOUR OWN QUESTIONS** based on the reading, and then pose them to your instructor and classmates for their consideration. Anticipate both correct and incorrect answers, the incorrect answer(s) assuming one or more plausible misconceptions. This helps you view the subject from different perspectives to grasp it more fully.

☑ Devise **EXPERIMENTS** to test claims presented in the reading, or to disprove misconceptions. Predict possible outcomes of these experiments, and evaluate their meanings: what result(s) would confirm, and what would constitute disproof? Running mental simulations and evaluating results is essential to scientific and diagnostic reasoning.

☑ Specifically identify any points you found **CONFUSING**. The reason for doing this is to help diagnose misconceptions and overcome barriers to learning.

4.1.2 Foundational concepts

Correct analysis and diagnosis of electric circuits begins with a proper understanding of some basic concepts. The following is a list of some important concepts referenced in this module's full tutorial. Define each of them in your own words, and be prepared to illustrate each of these concepts with a description of a practical example and/or a live demonstration.

Energy

Joule's Law

Electrical source

Electrical load

Fuse

Circuit breaker

Schematic diagram

Single-line diagram

Overcurrent protection

Relay pick-up

Polyphase

Normal state of a switch

Form-A contacts

Form-B contacts

Coordination

Induction disk

Seal-in contact

Inverse-time function

Definite-time function

Lenz's Law

Sensitivity

4.1.3 General Electric IAC77 relay

The following is an electrical schematic diagram for a General Electric model IAC77 electromechanical instantaneous/time-overcurrent protective relay:

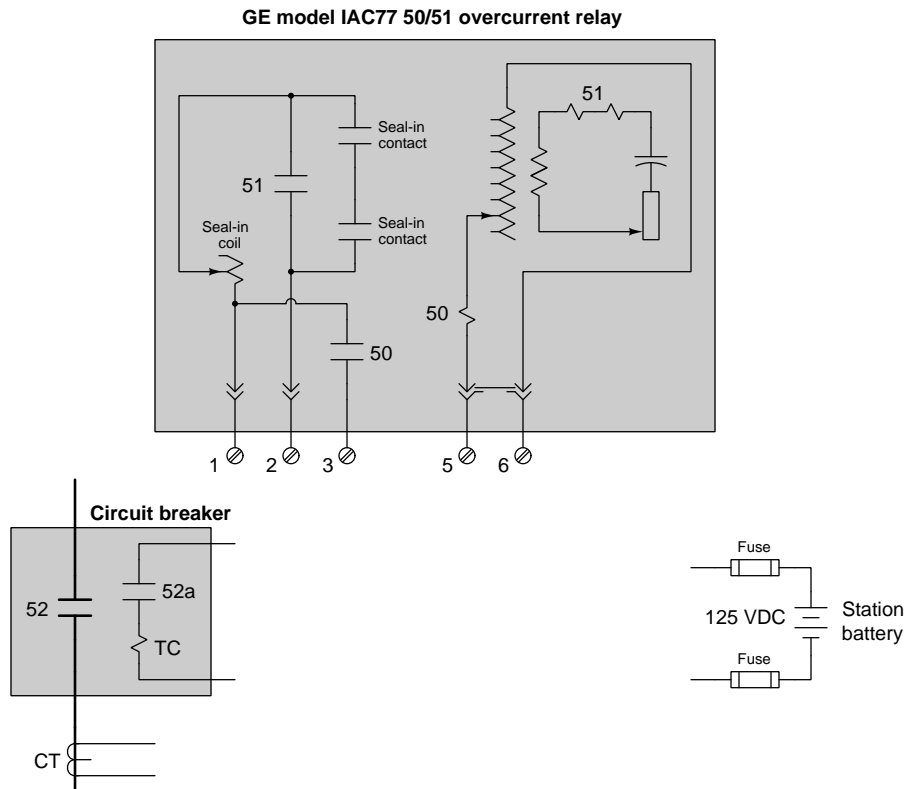

Identify the following:

- What type of symbol represents a coil of wire in this schematic
- What type of symbol represents a relay contact in this schematic
- What type of symbol represents a resistor in this schematic
- What type of symbol represents a capacitor in this schematic
- Where to connect the current transformer to the relay
- How to make coarse adjustments of the pick-up value for the 51 (time-overcurrent) function
- How to make fine adjustments of the pick-up value for the 51 (time-overcurrent) function
- How to make adjustments of the pick-up value for the 50 (instantaneous overcurrent) function
- The purpose of having a seal-in unit

- How to wire the relay so it only functions as a “50” (instantaneous overcurrent) unit
- How to wire the relay so it only functions as a “51” (time overcurrent) unit
- How to wire the relay so it performs both “50” and a “51” protective functions
- Why the circuit breaker has an auxiliary contact (52a) connected in series with the trip coil (note: this contact opens and closes simultaneously with the breaker’s main power contacts, being operated by the same mechanism)

Challenges

- One of the features of this draw-out relay design is that it automatically short-circuits the CT when disconnected from it. Identify where in the schematic diagram this shorting takes place.

4.1.4 Westinghouse CO-11 relay connections

Sketch all the necessary wire connections for this set of three Westinghouse model CO-11 overcurrent relays to fulfill both the 50 and 51 ANSI/IEEE protective functions. Note that Westinghouse refers to the time-overcurrent element as “CO” and the instantaneous overcurrent element as “IIT”:

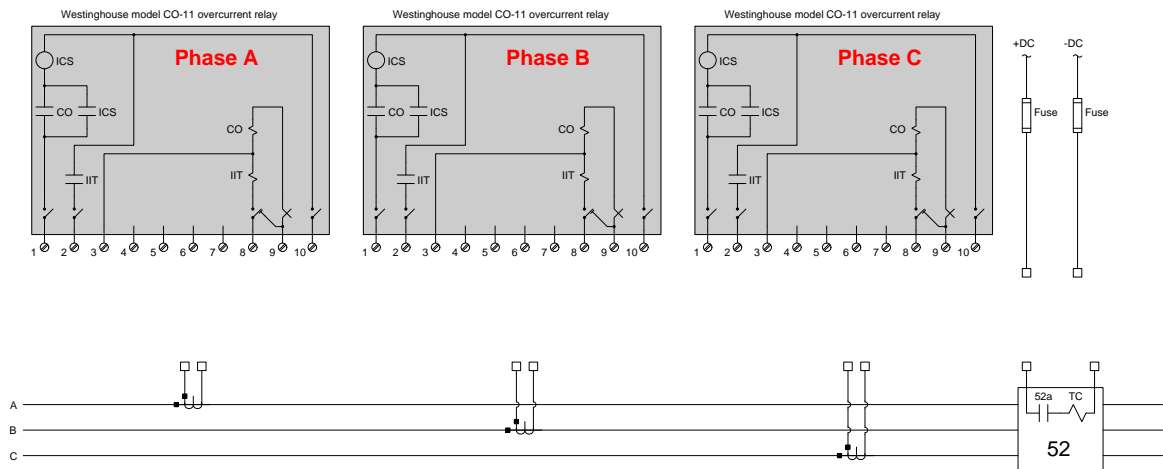

Challenges

- Identify where in each of the three relays’ schematic diagrams the CT shorting takes place to ensure safe disconnection of the relay from a live CT.

4.1.5 Fast bus trip scheme

A very important concept in overcurrent protection is something called *coordination*. This is where overcurrent-protection devices (e.g. fuses, circuit breakers, reclosers, protective relays) closer to the power source have trip thresholds greater than protection devices farther away from the source. The rationale behind coordination is to trip the smallest portion of the power grid necessary to clear the fault.

Examine this single-line diagram of a single-bus substation where incoming power arrives through a transmission line and exits to customer loads through four identical distribution feeder lines:

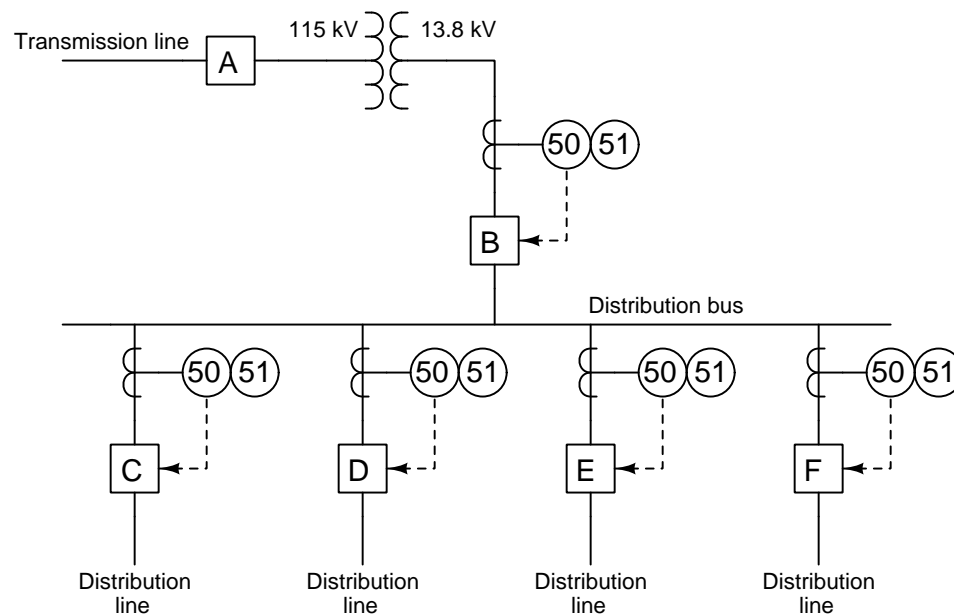

Identify which of the protective relays should have the highest pickup value and/or longest tripping time value, and which of the protective relays should have the lowest pickup/time values. Describe a “thought experiment” whereby these different pickup values help clear a distribution line fault most effectively.

Now, consider the following modification to this substation, incorporating a protection strategy known as *fast bus trip* scheme, also known as a *reverse interlocking* or *zone interlocking* scheme (shown in red):

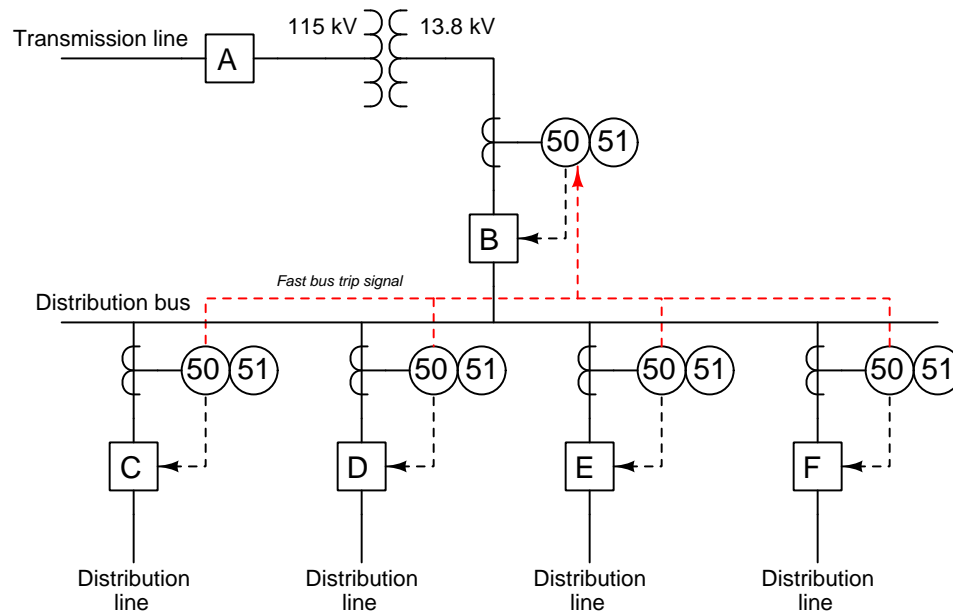

The purpose of a fast bus trip scheme is to detect and clear any faults on the substation bus by means of overcurrent relays faster than they would be cleared by the incoming line relay's regular action. The "fast bus trip signal" informs breaker B's relays whether or not high current is being sensed by any of the distribution breaker relays. Explain how this protection scheme uses information sent to the bus relay from the feeder relays to accomplish faster tripping. Again, describe a "thought experiment" that will illustrate the effectiveness of this protection scheme.

Challenges

- Identify a completely different protection scheme that would serve the same end.

4.2 Quantitative reasoning

These questions are designed to stimulate your computational thinking. In a Socratic discussion with your instructor, the goal is for these questions to reveal your mathematical approach(es) to problem-solving so that good technique and sound reasoning may be reinforced. Your instructor may also pose additional questions based on those assigned, in order to observe your problem-solving firsthand.

Mental arithmetic and estimations are strongly encouraged for all calculations, because without these abilities you will be unable to readily detect errors caused by calculator misuse (e.g. keystroke errors).

You will note a conspicuous lack of answers given for these quantitative questions. Unlike standard textbooks where answers to every other question are given somewhere toward the back of the book, here in these learning modules students must rely on other means to check their work. My advice is to use circuit simulation software such as SPICE to check the correctness of quantitative answers. Refer to those learning modules within this collection focusing on SPICE to see worked examples which you may use directly as practice problems for your own study, and/or as templates you may modify to run your own analyses and generate your own practice problems.

Completely worked example problems found in the Tutorial may also serve as “test cases⁴” for gaining proficiency in the use of circuit simulation software, and then once that proficiency is gained you will never need to rely⁵ on an answer key!

⁴In other words, set up the circuit simulation software to analyze the same circuit examples found in the Tutorial. If the simulated results match the answers shown in the Tutorial, it confirms the simulation has properly run. If the simulated results disagree with the Tutorial’s answers, something has been set up incorrectly in the simulation software. Using every Tutorial as practice in this way will quickly develop proficiency in the use of circuit simulation software.

⁵This approach is perfectly in keeping with the instructional philosophy of these learning modules: *teaching students to be self-sufficient thinkers*. Answer keys can be useful, but it is even more useful to your long-term success to have a set of tools on hand for checking your own work, because once you have left school and are on your own, there will no longer be “answer keys” available for the problems you will have to solve.

4.2.1 Miscellaneous physical constants

Note: constants shown in **bold** type are *exact*, not approximations. Values inside of parentheses show one standard deviation (σ) of uncertainty in the final digits: for example, the magnetic permeability of free space value given as $1.25663706212(19) \times 10^{-6}$ H/m represents a center value (i.e. the location parameter) of $1.25663706212 \times 10^{-6}$ Henrys per meter with one standard deviation of uncertainty equal to $0.0000000000019 \times 10^{-6}$ Henrys per meter.

Avogadro's number (N_A) = **6.02214076** $\times 10^{23}$ **per mole** (mol^{-1})

Boltzmann's constant (k) = **1.380649** $\times 10^{-23}$ **Joules per Kelvin** (J/K)

Electronic charge (e) = **1.602176634** $\times 10^{-19}$ **Coulomb** (C)

Faraday constant (F) = **96,485.33212...** $\times 10^4$ **Coulombs per mole** (C/mol)

Magnetic permeability of free space (μ_0) = $1.25663706212(19) \times 10^{-6}$ Henrys per meter (H/m)

Electric permittivity of free space (ϵ_0) = $8.8541878128(13) \times 10^{-12}$ Farads per meter (F/m)

Characteristic impedance of free space (Z_0) = $376.730313668(57)$ Ohms (Ω)

Gravitational constant (G) = $6.67430(15) \times 10^{-11}$ cubic meters per kilogram-seconds squared ($\text{m}^3/\text{kg}\cdot\text{s}^2$)

Molar gas constant (R) = **8.314462618...** **Joules per mole-Kelvin** (J/mol-K) = $0.08205746(14)$ liters-atmospheres per mole-Kelvin

Planck constant (h) = **6.62607015** $\times 10^{-34}$ **joule-seconds** (J-s)

Stefan-Boltzmann constant (σ) = **5.670374419...** $\times 10^{-8}$ **Watts per square meter-Kelvin⁴** ($\text{W}/\text{m}^2\cdot\text{K}^4$)

Speed of light in a vacuum (c) = **299,792,458 meters per second** (m/s) = 186282.4 miles per second (mi/s)

Note: All constants taken from NIST data "Fundamental Physical Constants – Complete Listing", from <http://physics.nist.gov/constants>, National Institute of Standards and Technology (NIST), 2018 CODATA Adjustment.

4.2.2 Introduction to spreadsheets

A powerful computational tool you are encouraged to use in your work is a *spreadsheet*. Available on most personal computers (e.g. Microsoft Excel), *spreadsheet* software performs numerical calculations based on number values and formulae entered into cells of a grid. This grid is typically arranged as lettered columns and numbered rows, with each cell of the grid identified by its column/row coordinates (e.g. cell B3, cell A8). Each cell may contain a string of text, a number value, or a mathematical formula. The spreadsheet automatically updates the results of all mathematical formulae whenever the entered number values are changed. This means it is possible to set up a spreadsheet to perform a series of calculations on entered data, and those calculations will be re-done by the computer any time the data points are edited in any way.

For example, the following spreadsheet calculates average speed based on entered values of distance traveled and time elapsed:

	A	B	C	D
1	Distance traveled	46.9	Kilometers	
2	Time elapsed	1.18	Hours	
3	Average speed	= B1 / B2	km/h	
4				
5				

Text labels contained in cells A1 through A3 and cells C1 through C3 exist solely for readability and are not involved in any calculations. Cell B1 contains a sample distance value while cell B2 contains a sample time value. The formula for computing speed is contained in cell B3. Note how this formula begins with an “equals” symbol (=), references the values for distance and speed by lettered column and numbered row coordinates (B1 and B2), and uses a forward slash symbol for division (/). The coordinates B1 and B2 function as *variables*⁶ would in an algebraic formula.

When this spreadsheet is executed, the numerical value 39.74576 will appear in cell B3 rather than the formula = B1 / B2, because 39.74576 is the computed speed value given 46.9 kilometers traveled over a period of 1.18 hours. If a different numerical value for distance is entered into cell B1 or a different value for time is entered into cell B2, cell B3’s value will automatically update. All you need to do is set up the given values and any formulae into the spreadsheet, and the computer will do all the calculations for you.

Cell B3 may be referenced by other formulae in the spreadsheet if desired, since it is a variable just like the given values contained in B1 and B2. This means it is possible to set up an entire chain of calculations, one dependent on the result of another, in order to arrive at a final value. The arrangement of the given data and formulae need not follow any pattern on the grid, which means you may place them anywhere.

⁶Spreadsheets may also provide means to attach text labels to cells for use as variable names (Microsoft Excel simply calls these labels “names”), but for simple spreadsheets such as those shown here it’s usually easier just to use the standard coordinate naming for each cell.

Common⁷ arithmetic operations available for your use in a spreadsheet include the following:

- Addition (+)
- Subtraction (-)
- Multiplication (*)
- Division (/)
- Powers (^)
- Square roots (sqrt())
- Logarithms (ln() , log10())

Parentheses may be used to ensure⁸ proper order of operations within a complex formula. Consider this example of a spreadsheet implementing the *quadratic formula*, used to solve for roots of a polynomial expression in the form of $ax^2 + bx + c$:

$$x = \frac{-b \pm \sqrt{b^2 - 4ac}}{2a}$$

	A	B
1	x_1	= (-B4 + sqrt((B4^2) - (4*B3*B5))) / (2*B3)
2	x_2	= (-B4 - sqrt((B4^2) - (4*B3*B5))) / (2*B3)
3	a =	9
4	b =	5
5	c =	-2

This example is configured to compute roots⁹ of the polynomial $9x^2 + 5x - 2$ because the values of 9, 5, and -2 have been inserted into cells B3, B4, and B5, respectively. Once this spreadsheet has been built, though, it may be used to calculate the roots of *any* second-degree polynomial expression simply by entering the new a , b , and c coefficients into cells B3 through B5. The numerical values appearing in cells B1 and B2 will be automatically updated by the computer immediately following any changes made to the coefficients.

⁷Modern spreadsheet software offers a bewildering array of mathematical functions you may use in your computations. I recommend you consult the documentation for your particular spreadsheet for information on operations other than those listed here.

⁸Spreadsheet programs, like text-based programming languages, are designed to follow standard order of operations by default. However, my personal preference is to use parentheses even where strictly unnecessary just to make it clear to any other person viewing the formula what the intended order of operations is.

⁹Reviewing some algebra here, a *root* is a value for x that yields an overall value of zero for the polynomial. For this polynomial ($9x^2 + 5x - 2$) the two roots happen to be $x = 0.269381$ and $x = -0.82494$, with these values displayed in cells B1 and B2, respectively upon execution of the spreadsheet.

Alternatively, one could break up the long quadratic formula into smaller pieces like this:

$$y = \sqrt{b^2 - 4ac} \quad z = 2a$$

$$x = \frac{-b \pm y}{z}$$

	A	B	C
1	x_1	= (-B4 + C1) / C2	= sqrt((B4^2) - (4*B3*B5))
2	x_2	= (-B4 - C1) / C2	= 2*B3
3	a =	9	
4	b =	5	
5	c =	-2	

Note how the square-root term (y) is calculated in cell C1, and the denominator term (z) in cell C2. This makes the two final formulae (in cells B1 and B2) simpler to interpret. The positioning of all these cells on the grid is completely arbitrary¹⁰ – all that matters is that they properly reference each other in the formulae.

Spreadsheets are particularly useful for situations where the same set of calculations representing a circuit or other system must be repeated for different initial conditions. The power of a spreadsheet is that it automates what would otherwise be a tedious set of calculations. One specific application of this is to simulate the effects of various components within a circuit failing with abnormal values (e.g. a shorted resistor simulated by making its value nearly zero; an open resistor simulated by making its value extremely large). Another application is analyzing the behavior of a circuit design given new components that are out of specification, and/or aging components experiencing drift over time.

¹⁰My personal preference is to locate all the “given” data in the upper-left cells of the spreadsheet grid (each data point flanked by a sensible name in the cell to the left and units of measurement in the cell to the right as illustrated in the first distance/time spreadsheet example), sometimes coloring them in order to clearly distinguish which cells contain entered data versus which cells contain computed results from formulae. I like to place all formulae in cells below the given data, and try to arrange them in logical order so that anyone examining my spreadsheet will be able to figure out *how* I constructed a solution. This is a general principle I believe all computer programmers should follow: *document and arrange your code to make it easy for other people to learn from it.*

4.2.3 Motor protection

Suppose a 51 (time-overcurrent) protective relay is used to provide protection for a large (3000 horsepower) electric motor. The motor runs on a line voltage of 4160 Volts, and has a full-load efficiency of 88%. The relay obtains its line current data from a set of three 400:5 current transformers on the motor's T1, T2, and T3 leads.

Based on this information, identify the *pick-up* current value for this protective relay, in secondary CT Amperes:

$$I_{pickup} =$$

Also, explain what other factor(s) will dictate the time dial setting and time-current curve type for this 51 relay to provide sufficient protection for the motor.

Challenges

- Why is a 51 relay the best choice for motor protection and not a 50 relay?

4.2.4 Three-phase 50/51 protection circuit

The following is an electrical schematic diagram for a three-phase 50/51 overcurrent protective relay circuit, where three overcurrent relays (one for each phase of the power circuit) trip a single breaker in the event of an overcurrent fault. The power diagram on the left shows all the high-voltage components, while the control diagram on the right shows the circuitry associated with the breaker's trip coil:

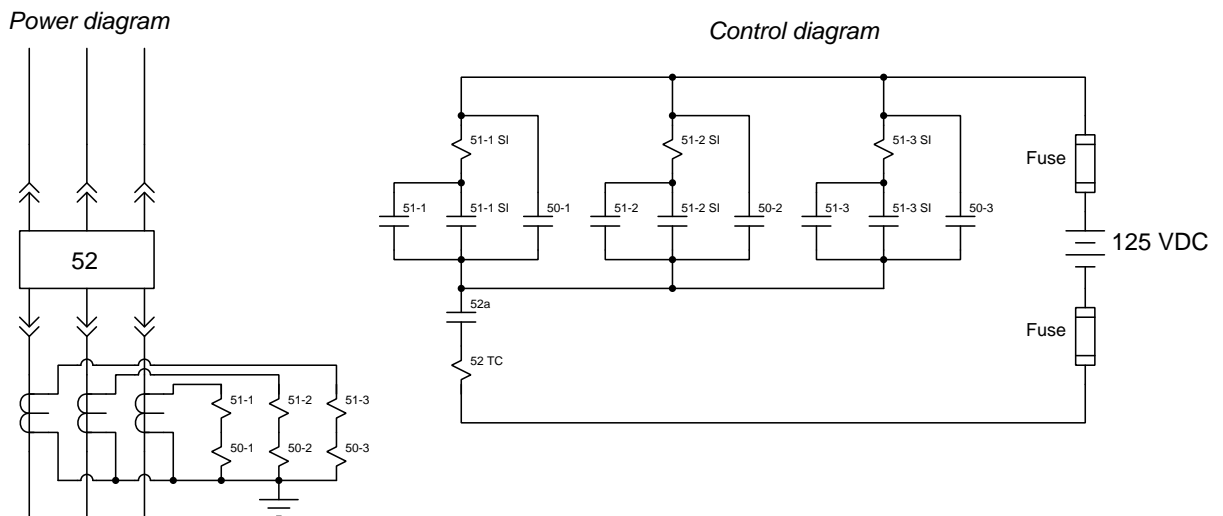

Examine this schematic diagram, and then explain how the circuit breaker may be tripped by *any one* of the three overcurrent relays. Also, identify at least one circuit fault in either the power diagram or the control diagram that could prevent the circuit breaker from tripping when it needs to.

Finally, calculate the amount of voltage dropped by the instantaneous sensing coil of one of the relays (coil 50-1, coil 50-2, or coil 50-3) when line current is 1300 Amperes at 60 Hz, assuming a 2000:5 CT ratio for each line, and given a coil resistance of 31.35 milliOhms and a coil inductance of 27.33 microHenrys:

$$V_{coil} =$$

Challenges

- Explain the purpose of the circuit breaker's *52a* contact shown in the control diagram.

4.2.5 Time dial setting

Calculate the necessary time-dial setting for a 51 protective relay with an “extremely inverse” characteristic assuming a pick-up (tap setting) of 5 Amperes, a CT ratio of 1200:5, and a desired trip time of 10 seconds for a fault current value of 3.6 kA.

Time dial setting =

Challenges

- ???.

4.2.6 Relay voltage drop

Calculate voltage dropped across the terminals of the protective relay during normal operation of this three-phase motor, being sure to express it as a phasor quantity. Assume a perfectly balanced system.

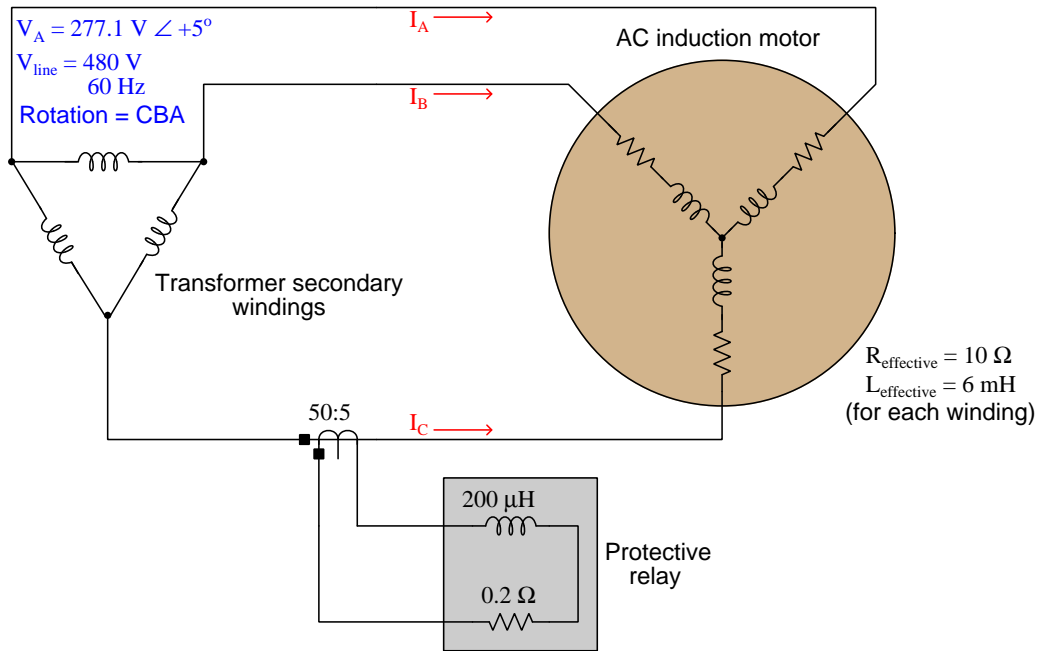

Challenges

- Is each transformer winding's current greater than, less than, or equal to the CT's primary current?.

4.2.7 Trip time simulation program

Write a computer program in a text-based language such as C, C++, or Python calculating the amount of time it will take an IEEE/ANSI-51 relay to trip given the sudden onset of an abnormally high current. Your program should input the line current value, the CT turns ratio, the relay's pick-up current rating (in secondary CT Amperes), the relay's time-dial setting, all assuming a *very inverse* characteristic.

Challenges

- What would need to change in your program to calculate trip time given some other curve such as “extremely inverse”?

4.3 Diagnostic reasoning

These questions are designed to stimulate your deductive and inductive thinking, where you must apply general principles to specific scenarios (deductive) and also derive conclusions about the failed circuit from specific details (inductive). In a Socratic discussion with your instructor, the goal is for these questions to reinforce your recall and use of general circuit principles and also challenge your ability to integrate multiple symptoms into a sensible explanation of what's wrong in a circuit. Your instructor may also pose additional questions based on those assigned, in order to further challenge and sharpen your diagnostic abilities.

As always, your goal is to fully *explain* your analysis of each problem. Simply obtaining a correct answer is not good enough – you must also demonstrate sound reasoning in order to successfully complete the assignment. Your instructor's responsibility is to probe and challenge your understanding of the relevant principles and analytical processes in order to ensure you have a strong foundation upon which to build further understanding.

You will note a conspicuous lack of answers given for these diagnostic questions. Unlike standard textbooks where answers to every other question are given somewhere toward the back of the book, here in these learning modules students must rely on other means to check their work. The best way by far is to debate the answers with fellow students and also with the instructor during the Socratic dialogue sessions intended to be used with these learning modules. Reasoning through challenging questions with other people is an excellent tool for developing strong reasoning skills.

Another means of checking your diagnostic answers, where applicable, is to use circuit simulation software to explore the effects of faults placed in circuits. For example, if one of these diagnostic questions requires that you predict the effect of an open or a short in a circuit, you may check the validity of your work by simulating that same fault (substituting a very high resistance in place of that component for an open, and substituting a very low resistance for a short) within software and seeing if the results agree.

4.3.1 Faulted 50/51 system

The following diagrams document the overcurrent protection system for a feeder supplying three-phase AC power to an industrial load:

Power diagram

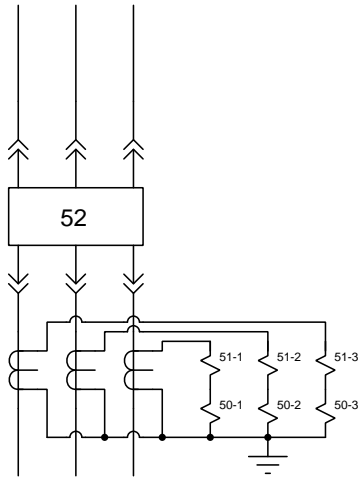

Control diagram

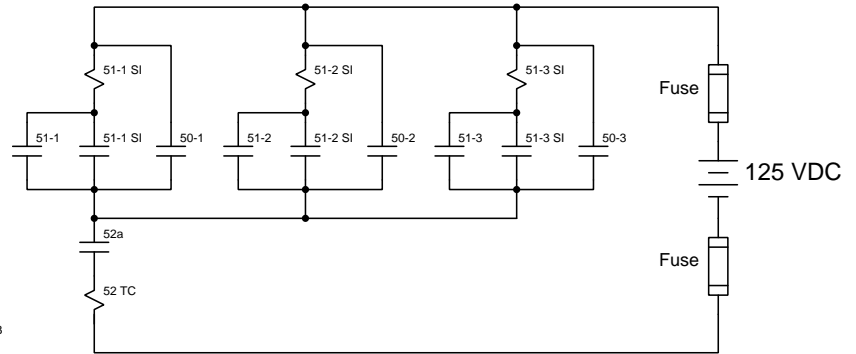

Suppose one day the circuit breaker (52) trips for no apparent reason. None of the brightly-colored “target” flags on the electromechanical protective relay are visible, as one would normally expect following a relay trip event. Identify the likelihood of each specified fault for this system. Consider each fault one at a time (i.e. no coincidental faults), determining whether or not each fault could independently account for *all* measurements and symptoms in this circuit.

- Dead DC station power supply
- 52/TC coil failed shorted
- 51-3/SI coil failed shorted
- 50-1 contact failed open
- 50-1 contact failed shorted
- 50-2 coil failed open
- 50-2 coil failed shorted
- 51-3 contact failed shorted

Also, identify which side of the 52 circuit breaker should be the “line” (supply) and which side should be the “load” in order for the 50/51 relay to provide maximum protection in this system.

Challenges

- Identify any faults not listed which could also account for the trip.

4.3.2 Feeder protection system

Examine this overcurrent protection system for a feeder, supplying three-phase power to a set of industrial loads from a substation bus:

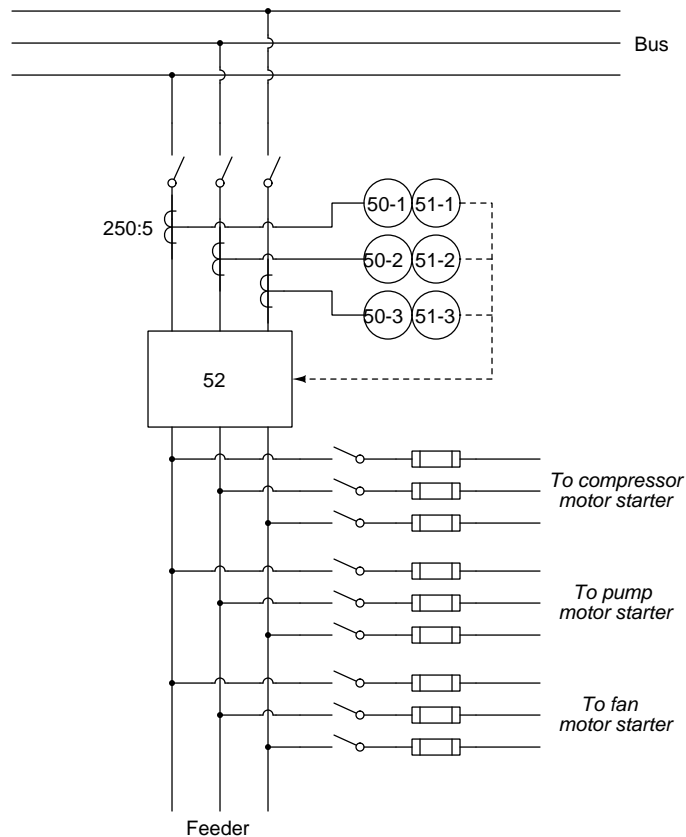

Explain why 50/51 overcurrent protection is necessary at all, since each of the loads has its own set of fuses to protect against overcurrent conditions.

Suppose the cable connecting phase 2 CT to the 50-2/51-2 relay fails shorted, such that the relay no longer senses current through that phase. Will the other two overcurrent relays continue to provide adequate protection? Explain why or why not, in detail.

Challenges

- Identify anywhere else in this system we might wish to install overcurrent protection of some form.

Appendix A

Problem-Solving Strategies

The ability to solve complex problems is arguably one of the most valuable skills one can possess, and this skill is particularly important in any science-based discipline.

- Study principles, not procedures. Don't be satisfied with merely knowing how to compute solutions – learn *why* those solutions work.
- Identify what it is you need to solve, identify all relevant data, identify all units of measurement, identify any general principles or formulae linking the given information to the solution, and then identify any “missing pieces” to a solution. Annotate all diagrams with this data.
- Sketch a diagram to help visualize the problem. When building a real system, always devise a plan for that system and analyze its function *before* constructing it.
- Follow the units of measurement and meaning of every calculation. If you are ever performing mathematical calculations as part of a problem-solving procedure, and you find yourself unable to apply each and every intermediate result to some aspect of the problem, it means you don't understand what you are doing. Properly done, every mathematical result should have practical meaning for the problem, and not just be an abstract number. You should be able to identify the proper units of measurement for each and every calculated result, and show where that result fits into the problem.
- Perform “thought experiments” to explore the effects of different conditions for theoretical problems. When troubleshooting real systems, perform *diagnostic tests* rather than visually inspecting for faults, the best diagnostic test being the one giving you the most information about the nature and/or location of the fault with the fewest steps.
- Simplify the problem until the solution becomes obvious, and then use that obvious case as a model to follow in solving the more complex version of the problem.
- Check for exceptions to see if your solution is incorrect or incomplete. A good solution will work for *all* known conditions and criteria. A good example of this is the process of testing scientific hypotheses: the task of a scientist is not to find support for a new idea, but rather to *challenge* that new idea to see if it holds up under a battery of tests. The philosophical

principle of *reductio ad absurdum* (i.e. disproving a general idea by finding a specific case where it fails) is useful here.

- Work “backward” from a hypothetical solution to a new set of given conditions.
- Add quantities to problems that are qualitative in nature, because sometimes a little math helps illuminate the scenario.
- Sketch graphs illustrating how variables relate to each other. These may be quantitative (i.e. with realistic number values) or qualitative (i.e. simply showing increases and decreases).
- Treat quantitative problems as qualitative in order to discern the relative magnitudes and/or directions of change of the relevant variables. For example, try determining what happens if a certain variable were to increase or decrease before attempting to precisely calculate quantities: how will each of the dependent variables respond, by increasing, decreasing, or remaining the same as before?
- Consider limiting cases. This works especially well for qualitative problems where you need to determine which direction a variable will change. Take the given condition and magnify that condition to an extreme degree as a way of simplifying the direction of the system’s response.
- Check your work. This means regularly testing your conclusions to see if they make sense. This does *not* mean repeating the same steps originally used to obtain the conclusion(s), but rather to use some other means to check validity. Simply repeating procedures often leads to *repeating the same errors* if any were made, which is why alternative paths are better.

Appendix B

Instructional philosophy

“The unexamined circuit is not worth energizing” – Socrates (if he had taught electricity)

These learning modules, although useful for self-study, were designed to be used in a formal learning environment where a subject-matter expert challenges students to digest the content and exercise their critical thinking abilities in the answering of questions and in the construction and testing of working circuits.

The following principles inform the instructional and assessment philosophies embodied in these learning modules:

- The first goal of education is to enhance clear and independent thought, in order that every student reach their fullest potential in a highly complex and inter-dependent world. Robust reasoning is *always* more important than particulars of any subject matter, because its application is universal.
- Literacy is fundamental to independent learning and thought because text continues to be the most efficient way to communicate complex ideas over space and time. Those who cannot read with ease are limited in their ability to acquire knowledge and perspective.
- Articulate communication is fundamental to work that is complex and interdisciplinary.
- Faulty assumptions and poor reasoning are best corrected through challenge, not presentation. The rhetorical technique of *reductio ad absurdum* (disproving an assertion by exposing an absurdity) works well to discipline student’s minds, not only to correct the problem at hand but also to learn how to detect and correct future errors.
- Important principles should be repeatedly explored and widely applied throughout a course of study, not only to reinforce their importance and help ensure their mastery, but also to showcase the interconnectedness and utility of knowledge.

These learning modules were expressly designed to be used in an “inverted” teaching environment¹ where students first read the introductory and tutorial chapters on their own, then individually attempt to answer the questions and construct working circuits according to the experiment and project guidelines. The instructor never lectures, but instead meets regularly with each individual student to review their progress, answer questions, identify misconceptions, and challenge the student to new depths of understanding through further questioning. Regular meetings between instructor and student should resemble a Socratic² dialogue, where questions serve as scalpels to dissect topics and expose assumptions. The student passes each module only after consistently demonstrating their ability to logically analyze and correctly apply all major concepts in each question or project/experiment. The instructor must be vigilant in probing each student’s understanding to ensure they are truly *reasoning* and not just *memorizing*. This is why “Challenge” points appear throughout, as prompts for students to think deeper about topics and as starting points for instructor queries. Sometimes these challenge points require additional knowledge that hasn’t been covered in the series to answer in full. This is okay, as the major purpose of the Challenges is to stimulate analysis and synthesis on the part of each student.

The instructor must possess enough mastery of the subject matter and awareness of students’ reasoning to generate their own follow-up questions to practically any student response. Even completely correct answers given by the student should be challenged by the instructor for the purpose of having students practice articulating their thoughts and defending their reasoning. Conceptual errors committed by the student should be exposed and corrected not by direct instruction, but rather by reducing the errors to an absurdity³ through well-chosen questions and thought experiments posed by the instructor. Becoming proficient at this style of instruction requires time and dedication, but the positive effects on critical thinking for both student and instructor are spectacular.

An inspection of these learning modules reveals certain unique characteristics. One of these is a bias toward thorough explanations in the tutorial chapters. Without a live instructor to explain concepts and applications to students, the text itself must fulfill this role. This philosophy results in lengthier explanations than what you might typically find in a textbook, each step of the reasoning process fully explained, including footnotes addressing common questions and concerns students raise while learning these concepts. Each tutorial seeks to not only explain each major concept in sufficient detail, but also to explain the logic of each concept and how each may be developed

¹In a traditional teaching environment, students first encounter new information via *lecture* from an expert, and then independently apply that information via *homework*. In an “inverted” course of study, students first encounter new information via *homework*, and then independently apply that information under the scrutiny of an expert. The expert’s role in lecture is to simply *explain*, but the expert’s role in an inverted session is to *challenge, critique*, and if necessary *explain* where gaps in understanding still exist.

²Socrates is a figure in ancient Greek philosophy famous for his unflinching style of questioning. Although he authored no texts, he appears as a character in Plato’s many writings. The essence of Socratic philosophy is to leave no question unexamined and no point of view unchallenged. While purists may argue a topic such as electric circuits is too narrow for a true Socratic-style dialogue, I would argue that the essential thought processes involved with scientific reasoning on *any* topic are not far removed from the Socratic ideal, and that students of electricity and electronics would do very well to challenge assumptions, pose thought experiments, identify fallacies, and otherwise employ the arsenal of critical thinking skills modeled by Socrates.

³This rhetorical technique is known by the Latin phrase *reductio ad absurdum*. The concept is to expose errors by counter-example, since only one solid counter-example is necessary to disprove a universal claim. As an example of this, consider the common misconception among beginning students of electricity that voltage cannot exist without current. One way to apply *reductio ad absurdum* to this statement is to ask how much current passes through a fully-charged battery connected to nothing (i.e. a clear example of voltage existing without current).

from “first principles”. Again, this reflects the goal of developing clear and independent thought in students’ minds, by showing how clear and logical thought was used to forge each concept. Students benefit from witnessing a model of clear thinking in action, and these tutorials strive to be just that.

Another characteristic of these learning modules is a lack of step-by-step instructions in the Project and Experiment chapters. Unlike many modern workbooks and laboratory guides where step-by-step instructions are prescribed for each experiment, these modules take the approach that students must learn to closely read the tutorials and apply their own reasoning to identify the appropriate experimental steps. Sometimes these steps are plainly declared in the text, just not as a set of enumerated points. At other times certain steps are implied, an example being assumed competence in test equipment use where the student should not need to be told *again* how to use their multimeter because that was thoroughly explained in previous lessons. In some circumstances no steps are given at all, leaving the entire procedure up to the student.

This lack of prescription is not a flaw, but rather a feature. Close reading and clear thinking are foundational principles of this learning series, and in keeping with this philosophy all activities are designed to *require* those behaviors. Some students may find the lack of prescription frustrating, because it demands more from them than what their previous educational experiences required. This frustration should be interpreted as an unfamiliarity with autonomous thinking, a problem which must be corrected if the student is ever to become a self-directed learner and effective problem-solver. Ultimately, the need for students to read closely and think clearly is more important both in the near-term and far-term than any specific facet of the subject matter at hand. If a student takes longer than expected to complete a module because they are forced to outline, digest, and reason on their own, so be it. The future gains enjoyed by developing this mental discipline will be well worth the additional effort and delay.

Another feature of these learning modules is that they do not treat topics in isolation. Rather, important concepts are introduced early in the series, and appear repeatedly as stepping-stones toward other concepts in subsequent modules. This helps to avoid the “compartmentalization” of knowledge, demonstrating the inter-connectedness of concepts and simultaneously reinforcing them. Each module is fairly complete in itself, reserving the beginning of its tutorial to a review of foundational concepts.

This methodology of assigning text-based modules to students for digestion and then using Socratic dialogue to assess progress and hone students’ thinking was developed over a period of several years by the author with his Electronics and Instrumentation students at the two-year college level. While decidedly unconventional and sometimes even unsettling for students accustomed to a more passive lecture environment, this instructional philosophy has proven its ability to convey conceptual mastery, foster careful analysis, and enhance employability so much better than lecture that the author refuses to ever teach by lecture again.

Problems which often go undiagnosed in a lecture environment are laid bare in this “inverted” format where students must articulate and logically defend their reasoning. This, too, may be unsettling for students accustomed to lecture sessions where the instructor cannot tell for sure who comprehends and who does not, and this vulnerability necessitates sensitivity on the part of the “inverted” session instructor in order that students never feel discouraged by having their errors exposed. *Everyone* makes mistakes from time to time, and learning is a lifelong process! Part of the instructor’s job is to build a culture of learning among the students where errors are not seen as shameful, but rather as opportunities for progress.

To this end, instructors managing courses based on these modules should adhere to the following principles:

- Student questions are always welcome and demand thorough, honest answers. The only type of question an instructor should refuse to answer is one the student should be able to easily answer on their own. Remember, *the fundamental goal of education is for each student to learn to think clearly and independently*. This requires hard work on the part of the student, which no instructor should ever circumvent. Anything done to bypass the student's responsibility to do that hard work ultimately limits that student's potential and thereby does real harm.
- It is not only permissible, but encouraged, to answer a student's question by asking questions in return, these follow-up questions designed to guide the student to reach a correct answer through their own reasoning.
- All student answers demand to be challenged by the instructor and/or by other students. This includes both correct and incorrect answers – the goal is to practice the articulation and defense of one's own reasoning.
- No reading assignment is deemed complete unless and until the student demonstrates their ability to accurately summarize the major points in their own terms. Recitation of the original text is unacceptable. This is why every module contains an "Outline and reflections" question as well as a "Foundational concepts" question in the Conceptual reasoning section, to prompt reflective reading.
- No assigned question is deemed answered unless and until the student demonstrates their ability to consistently and correctly apply the concepts to *variations* of that question. This is why module questions typically contain multiple "Challenges" suggesting different applications of the concept(s) as well as variations on the same theme(s). Instructors are encouraged to devise as many of their own "Challenges" as they are able, in order to have a multitude of ways ready to probe students' understanding.
- No assigned experiment or project is deemed complete unless and until the student demonstrates the task in action. If this cannot be done "live" before the instructor, video-recordings showing the demonstration are acceptable. All relevant safety precautions must be followed, all test equipment must be used correctly, and the student must be able to properly explain all results. The student must also successfully answer all Challenges presented by the instructor for that experiment or project.

Students learning from these modules would do well to abide by the following principles:

- No text should be considered fully and adequately read unless and until you can express every idea *in your own words, using your own examples*.
- You should always articulate your thoughts as you read the text, noting points of agreement, confusion, and epiphanies. Feel free to print the text on paper and then write your notes in the margins. Alternatively, keep a journal for your own reflections as you read. This is truly a helpful tool when digesting complicated concepts.
- Never take the easy path of highlighting or underlining important text. Instead, *summarize* and/or *comment* on the text using your own words. This actively engages your mind, allowing you to more clearly perceive points of confusion or misunderstanding on your own.
- A very helpful strategy when learning new concepts is to place yourself in the role of a teacher, if only as a mental exercise. Either explain what you have recently learned to someone else, or at least *imagine* yourself explaining what you have learned to someone else. The simple act of having to articulate new knowledge and skill forces you to take on a different perspective, and will help reveal weaknesses in your understanding.
- Perform each and every mathematical calculation and thought experiment shown in the text on your own, referring back to the text to see that your results agree. This may seem trivial and unnecessary, but it is critically important to ensuring you actually understand what is presented, especially when the concepts at hand are complicated and easy to misunderstand. Apply this same strategy to become proficient in the use of *circuit simulation software*, checking to see if your simulated results agree with the results shown in the text.
- Above all, recognize that learning is hard work, and that a certain level of frustration is unavoidable. There are times when you will struggle to grasp some of these concepts, and that struggle is a natural thing. Take heart that it will yield with persistent and varied⁴ effort, and never give up!

Students interested in using these modules for self-study will also find them beneficial, although the onus of responsibility for thoroughly reading and answering questions will of course lie with that individual alone. If a qualified instructor is not available to challenge students, a workable alternative is for students to form study groups where they challenge⁵ one another.

To high standards of education,

Tony R. Kuphaldt

⁴As the old saying goes, “Insanity is trying the same thing over and over again, expecting different results.” If you find yourself stumped by something in the text, you should attempt a different approach. Alter the thought experiment, change the mathematical parameters, do whatever you can to see the problem in a slightly different light, and then the solution will often present itself more readily.

⁵Avoid the temptation to simply share answers with study partners, as this is really counter-productive to learning. Always bear in mind that the answer to any question is far less important in the long run than the method(s) used to obtain that answer. The goal of education is to empower one’s life through the improvement of clear and independent thought, literacy, expression, and various practical skills.

Appendix C

Tools used

I am indebted to the developers of many open-source software applications in the creation of these learning modules. The following is a list of these applications with some commentary on each.

You will notice a theme common to many of these applications: a bias toward *code*. Although I am by no means an expert programmer in any computer language, I understand and appreciate the flexibility offered by code-based applications where the user (you) enters commands into a plain ASCII text file, which the software then reads and processes to create the final output. Code-based computer applications are by their very nature *extensible*, while WYSIWYG (What You See Is What You Get) applications are generally limited to whatever user interface the developer makes for you.

The GNU/Linux computer operating system

There is so much to be said about Linus Torvalds' `Linux` and Richard Stallman's `GNU` project. First, to credit just these two individuals is to fail to do justice to the *mob* of passionate volunteers who contributed to make this amazing software a reality. I first learned of `Linux` back in 1996, and have been using this operating system on my personal computers almost exclusively since then. It is *free*, it is completely *configurable*, and it permits the continued use of highly efficient `Unix` applications and scripting languages (e.g. shell scripts, Makefiles, `sed`, `awk`) developed over many decades. `Linux` not only provided me with a powerful computing platform, but its open design served to inspire my life's work of creating open-source educational resources.

Bram Moolenaar's Vim text editor

Writing code for any code-based computer application requires a *text editor*, which may be thought of as a word processor strictly limited to outputting plain-ASCII text files. Many good text editors exist, and one's choice of text editor seems to be a deeply personal matter within the programming world. I prefer `Vim` because it operates very similarly to `vi` which is ubiquitous on `Unix/Linux` operating systems, and because it may be entirely operated via keyboard (i.e. no mouse required) which makes it fast to use.

Donald Knuth's \TeX typesetting system

Developed in the late 1970's and early 1980's by computer scientist extraordinaire Donald Knuth to typeset his multi-volume magnum opus *The Art of Computer Programming*, this software allows the production of formatted text for screen-viewing or paper printing, all by writing plain-text code to describe how the formatted text is supposed to appear. \TeX is not just a markup language for documents, but it is also a Turing-complete programming language in and of itself, allowing useful algorithms to be created to control the production of documents. Simply put, *\TeX is a programmer's approach to word processing*. Since \TeX is controlled by code written in a plain-text file, this means anyone may read that plain-text file to see exactly how the document was created. This openness afforded by the code-based nature of \TeX makes it relatively easy to learn how other people have created their own \TeX documents. By contrast, examining a beautiful document created in a conventional WYSIWYG word processor such as Microsoft **Word** suggests nothing to the reader about *how* that document was created, or what the user might do to create something similar. As Mr. Knuth himself once quipped, conventional word processing applications should be called WYSIAYG (What You See Is *All* You Get).

Leslie Lamport's \LaTeX extensions to \TeX

Like all true programming languages, \TeX is inherently extensible. So, years after the release of \TeX to the public, Leslie Lamport decided to create a massive extension allowing easier compilation of book-length documents. The result was \LaTeX , which is the markup language used to create all ModEL module documents. You could say that \TeX is to \LaTeX as **C** is to **C++**. This means it is permissible to use any and all \TeX commands within \LaTeX source code, and it all still works. Some of the features offered by \LaTeX that would be challenging to implement in \TeX include automatic index and table-of-content creation.

Tim Edwards' **Xcircuit** drafting program

This wonderful program is what I use to create all the schematic diagrams and illustrations (but not photographic images or mathematical plots) throughout the ModEL project. It natively outputs PostScript format which is a true vector graphic format (this is why the images do not pixellate when you zoom in for a closer view), and it is so simple to use that I have never had to read the manual! Object libraries are easy to create for **Xcircuit**, being plain-text files using PostScript programming conventions. Over the years I have collected a large set of object libraries useful for drawing electrical and electronic schematics, pictorial diagrams, and other technical illustrations.

Gimp graphic image manipulation program

Essentially an open-source clone of Adobe's `PhotoShop`, I use `Gimp` to resize, crop, and convert file formats for all of the photographic images appearing in the `MODEL` modules. Although `Gimp` does offer its own scripting language (called `Script-Fu`), I have never had occasion to use it. Thus, my utilization of `Gimp` to merely crop, resize, and convert graphic images is akin to using a sword to slice bread.

SPICE circuit simulation program

`SPICE` is to circuit analysis as `TEX` is to document creation: it is a form of markup language designed to describe a certain object to be processed in plain-ASCII text. When the plain-text "source file" is compiled by the software, it outputs the final result. More modern circuit analysis tools certainly exist, but I prefer `SPICE` for the following reasons: it is *free*, it is *fast*, it is *reliable*, and it is a fantastic tool for *teaching* students of electricity and electronics how to write simple code. I happen to use rather old versions of `SPICE`, version 2g6 being my "go to" application when I only require text-based output. `NGSPICE` (version 26), which is based on Berkeley `SPICE` version 3f5, is used when I require graphical output for such things as time-domain waveforms and Bode plots. In all `SPICE` example netlists I strive to use coding conventions compatible with all `SPICE` versions.

Andrew D. Hwang's ePiX mathematical visualization programming library

This amazing project is a `C++` library you may link to any `C/C++` code for the purpose of generating PostScript graphic images of mathematical functions. As a completely free and open-source project, it does all the plotting I would otherwise use a Computer Algebra System (CAS) such as `Mathematica` or `Maple` to do. It should be said that `ePiX` is *not* a Computer Algebra System like `Mathematica` or `Maple`, but merely a mathematical *visualization* tool. In other words, it won't determine integrals for you (you'll have to implement that in your own `C/C++` code!), but it can graph the results, and it does so beautifully. What I really admire about `ePiX` is that it is a `C++` programming library, which means it builds on the existing power and toolset available with that programming language. Mr. Hwang could have probably developed his own stand-alone application for mathematical plotting, but by creating a `C++` library to do the same thing he accomplished something much greater.

gnuplot mathematical visualization software

Another open-source tool for mathematical visualization is `gnuplot`. Interestingly, this tool is *not* part of Richard Stallman’s GNU project, its name being a coincidence. For this reason the authors prefer “gnu” *not* be capitalized at all to avoid confusion. This is a much “lighter-weight” alternative to a spreadsheet for plotting tabular data, and the fact that it easily outputs directly to an X11 console or a file in a number of different graphical formats (including PostScript) is very helpful. I typically set my `gnuplot` output format to default (X11 on my Linux PC) for quick viewing while I’m developing a visualization, then switch to PostScript file export once the visual is ready to include in the document(s) I’m writing. As with my use of `Gimp` to do rudimentary image editing, my use of `gnuplot` only scratches the surface of its capabilities, but the important points are that it’s *free* and that it *works well*.

Python programming language

Both Python and C++ find extensive use in these modules as instructional aids and exercises, but I’m listing Python here as a *tool* for myself because I use it almost daily as a *calculator*. If you open a Python interpreter console and type `from math import *` you can type mathematical expressions and have it return results just as you would on a hand calculator. Complex-number (i.e. *phasor*) arithmetic is similarly supported if you include the complex-math library (`from cmath import *`). Examples of this are shown in the Programming References chapter (if included) in each module. Of course, being a fully-featured programming language, Python also supports conditionals, loops, and other structures useful for calculation of quantities. Also, running in a console environment where all entries and returned values show as text in a chronologically-ordered list makes it easy to copy-and-paste those calculations to document exactly how they were performed.

Appendix D

Creative Commons License

Creative Commons Attribution 4.0 International Public License

By exercising the Licensed Rights (defined below), You accept and agree to be bound by the terms and conditions of this Creative Commons Attribution 4.0 International Public License (“Public License”). To the extent this Public License may be interpreted as a contract, You are granted the Licensed Rights in consideration of Your acceptance of these terms and conditions, and the Licensor grants You such rights in consideration of benefits the Licensor receives from making the Licensed Material available under these terms and conditions.

Section 1 – Definitions.

a. **Adapted Material** means material subject to Copyright and Similar Rights that is derived from or based upon the Licensed Material and in which the Licensed Material is translated, altered, arranged, transformed, or otherwise modified in a manner requiring permission under the Copyright and Similar Rights held by the Licensor. For purposes of this Public License, where the Licensed Material is a musical work, performance, or sound recording, Adapted Material is always produced where the Licensed Material is synched in timed relation with a moving image.

b. **Adapter’s License** means the license You apply to Your Copyright and Similar Rights in Your contributions to Adapted Material in accordance with the terms and conditions of this Public License.

c. **Copyright and Similar Rights** means copyright and/or similar rights closely related to copyright including, without limitation, performance, broadcast, sound recording, and Sui Generis Database Rights, without regard to how the rights are labeled or categorized. For purposes of this Public License, the rights specified in Section 2(b)(1)-(2) are not Copyright and Similar Rights.

d. **Effective Technological Measures** means those measures that, in the absence of proper authority, may not be circumvented under laws fulfilling obligations under Article 11 of the WIPO Copyright Treaty adopted on December 20, 1996, and/or similar international agreements.

e. **Exceptions and Limitations** means fair use, fair dealing, and/or any other exception or

limitation to Copyright and Similar Rights that applies to Your use of the Licensed Material.

f. **Licensed Material** means the artistic or literary work, database, or other material to which the Licensor applied this Public License.

g. **Licensed Rights** means the rights granted to You subject to the terms and conditions of this Public License, which are limited to all Copyright and Similar Rights that apply to Your use of the Licensed Material and that the Licensor has authority to license.

h. **Licensor** means the individual(s) or entity(ies) granting rights under this Public License.

i. **Share** means to provide material to the public by any means or process that requires permission under the Licensed Rights, such as reproduction, public display, public performance, distribution, dissemination, communication, or importation, and to make material available to the public including in ways that members of the public may access the material from a place and at a time individually chosen by them.

j. **Sui Generis Database Rights** means rights other than copyright resulting from Directive 96/9/EC of the European Parliament and of the Council of 11 March 1996 on the legal protection of databases, as amended and/or succeeded, as well as other essentially equivalent rights anywhere in the world.

k. **You** means the individual or entity exercising the Licensed Rights under this Public License. **Your** has a corresponding meaning.

Section 2 – Scope.

a. License grant.

1. Subject to the terms and conditions of this Public License, the Licensor hereby grants You a worldwide, royalty-free, non-sublicensable, non-exclusive, irrevocable license to exercise the Licensed Rights in the Licensed Material to:

A. reproduce and Share the Licensed Material, in whole or in part; and

B. produce, reproduce, and Share Adapted Material.

2. Exceptions and Limitations. For the avoidance of doubt, where Exceptions and Limitations apply to Your use, this Public License does not apply, and You do not need to comply with its terms and conditions.

3. Term. The term of this Public License is specified in Section 6(a).

4. Media and formats; technical modifications allowed. The Licensor authorizes You to exercise the Licensed Rights in all media and formats whether now known or hereafter created, and to make technical modifications necessary to do so. The Licensor waives and/or agrees not to assert any right or authority to forbid You from making technical modifications necessary to exercise the Licensed Rights, including technical modifications necessary to circumvent Effective Technological Measures.

For purposes of this Public License, simply making modifications authorized by this Section 2(a)(4) never produces Adapted Material.

5. Downstream recipients.

A. Offer from the Licensor – Licensed Material. Every recipient of the Licensed Material automatically receives an offer from the Licensor to exercise the Licensed Rights under the terms and conditions of this Public License.

B. No downstream restrictions. You may not offer or impose any additional or different terms or conditions on, or apply any Effective Technological Measures to, the Licensed Material if doing so restricts exercise of the Licensed Rights by any recipient of the Licensed Material.

6. No endorsement. Nothing in this Public License constitutes or may be construed as permission to assert or imply that You are, or that Your use of the Licensed Material is, connected with, or sponsored, endorsed, or granted official status by, the Licensor or others designated to receive attribution as provided in Section 3(a)(1)(A)(i).

b. Other rights.

1. Moral rights, such as the right of integrity, are not licensed under this Public License, nor are publicity, privacy, and/or other similar personality rights; however, to the extent possible, the Licensor waives and/or agrees not to assert any such rights held by the Licensor to the limited extent necessary to allow You to exercise the Licensed Rights, but not otherwise.

2. Patent and trademark rights are not licensed under this Public License.

3. To the extent possible, the Licensor waives any right to collect royalties from You for the exercise of the Licensed Rights, whether directly or through a collecting society under any voluntary or waivable statutory or compulsory licensing scheme. In all other cases the Licensor expressly reserves any right to collect such royalties.

Section 3 – License Conditions.

Your exercise of the Licensed Rights is expressly made subject to the following conditions.

a. Attribution.

1. If You Share the Licensed Material (including in modified form), You must:

A. retain the following if it is supplied by the Licensor with the Licensed Material:

i. identification of the creator(s) of the Licensed Material and any others designated to receive attribution, in any reasonable manner requested by the Licensor (including by pseudonym if designated);

ii. a copyright notice;

- iii. a notice that refers to this Public License;
- iv. a notice that refers to the disclaimer of warranties;
- v. a URI or hyperlink to the Licensed Material to the extent reasonably practicable;

B. indicate if You modified the Licensed Material and retain an indication of any previous modifications; and

C. indicate the Licensed Material is licensed under this Public License, and include the text of, or the URI or hyperlink to, this Public License.

2. You may satisfy the conditions in Section 3(a)(1) in any reasonable manner based on the medium, means, and context in which You Share the Licensed Material. For example, it may be reasonable to satisfy the conditions by providing a URI or hyperlink to a resource that includes the required information.

3. If requested by the Licensor, You must remove any of the information required by Section 3(a)(1)(A) to the extent reasonably practicable.

4. If You Share Adapted Material You produce, the Adapter's License You apply must not prevent recipients of the Adapted Material from complying with this Public License.

Section 4 – Sui Generis Database Rights.

Where the Licensed Rights include Sui Generis Database Rights that apply to Your use of the Licensed Material:

- a. for the avoidance of doubt, Section 2(a)(1) grants You the right to extract, reuse, reproduce, and Share all or a substantial portion of the contents of the database;
- b. if You include all or a substantial portion of the database contents in a database in which You have Sui Generis Database Rights, then the database in which You have Sui Generis Database Rights (but not its individual contents) is Adapted Material; and
- c. You must comply with the conditions in Section 3(a) if You Share all or a substantial portion of the contents of the database.

For the avoidance of doubt, this Section 4 supplements and does not replace Your obligations under this Public License where the Licensed Rights include other Copyright and Similar Rights.

Section 5 – Disclaimer of Warranties and Limitation of Liability.

a. Unless otherwise separately undertaken by the Licensor, to the extent possible, the Licensor offers the Licensed Material as-is and as-available, and makes no representations or warranties of any kind concerning the Licensed Material, whether express, implied, statutory, or other. This includes, without limitation, warranties of title, merchantability, fitness for a particular purpose, non-infringement, absence of latent or other defects, accuracy, or the presence or absence of errors,

whether or not known or discoverable. Where disclaimers of warranties are not allowed in full or in part, this disclaimer may not apply to You.

b. To the extent possible, in no event will the Licensor be liable to You on any legal theory (including, without limitation, negligence) or otherwise for any direct, special, indirect, incidental, consequential, punitive, exemplary, or other losses, costs, expenses, or damages arising out of this Public License or use of the Licensed Material, even if the Licensor has been advised of the possibility of such losses, costs, expenses, or damages. Where a limitation of liability is not allowed in full or in part, this limitation may not apply to You.

c. The disclaimer of warranties and limitation of liability provided above shall be interpreted in a manner that, to the extent possible, most closely approximates an absolute disclaimer and waiver of all liability.

Section 6 – Term and Termination.

a. This Public License applies for the term of the Copyright and Similar Rights licensed here. However, if You fail to comply with this Public License, then Your rights under this Public License terminate automatically.

b. Where Your right to use the Licensed Material has terminated under Section 6(a), it reinstates:

1. automatically as of the date the violation is cured, provided it is cured within 30 days of Your discovery of the violation; or

2. upon express reinstatement by the Licensor.

For the avoidance of doubt, this Section 6(b) does not affect any right the Licensor may have to seek remedies for Your violations of this Public License.

c. For the avoidance of doubt, the Licensor may also offer the Licensed Material under separate terms or conditions or stop distributing the Licensed Material at any time; however, doing so will not terminate this Public License.

d. Sections 1, 5, 6, 7, and 8 survive termination of this Public License.

Section 7 – Other Terms and Conditions.

a. The Licensor shall not be bound by any additional or different terms or conditions communicated by You unless expressly agreed.

b. Any arrangements, understandings, or agreements regarding the Licensed Material not stated herein are separate from and independent of the terms and conditions of this Public License.

Section 8 – Interpretation.

a. For the avoidance of doubt, this Public License does not, and shall not be interpreted to, reduce, limit, restrict, or impose conditions on any use of the Licensed Material that could lawfully

be made without permission under this Public License.

b. To the extent possible, if any provision of this Public License is deemed unenforceable, it shall be automatically reformed to the minimum extent necessary to make it enforceable. If the provision cannot be reformed, it shall be severed from this Public License without affecting the enforceability of the remaining terms and conditions.

c. No term or condition of this Public License will be waived and no failure to comply consented to unless expressly agreed to by the Licensor.

d. Nothing in this Public License constitutes or may be interpreted as a limitation upon, or waiver of, any privileges and immunities that apply to the Licensor or You, including from the legal processes of any jurisdiction or authority.

Creative Commons is not a party to its public licenses. Notwithstanding, Creative Commons may elect to apply one of its public licenses to material it publishes and in those instances will be considered the “Licensor.” Except for the limited purpose of indicating that material is shared under a Creative Commons public license or as otherwise permitted by the Creative Commons policies published at creativecommons.org/policies, Creative Commons does not authorize the use of the trademark “Creative Commons” or any other trademark or logo of Creative Commons without its prior written consent including, without limitation, in connection with any unauthorized modifications to any of its public licenses or any other arrangements, understandings, or agreements concerning use of licensed material. For the avoidance of doubt, this paragraph does not form part of the public licenses.

Creative Commons may be contacted at creativecommons.org.

Appendix E

References

Blackburn, J. Lewis and Domin, Thomas J., *Protective Relaying Principles and Applications*, Third Edition, CRC Press, Taylor & Francis Group, Boca Raton, FL, 2007.

Choubey, Tribhuvan, “Communication Aided Protection Schemes”, Southern California Edison presentation.

Mason, C. Russell, *The Art and Science of Protective Relaying*, First Edition, John Wiley & Sons, 1956.

Protection and Control Reference Guide, Volume 22, GE Digital Energy, 2009.

“SEL-551 Relay instruction manual”, PM551-01, Schweitzer Engineering Laboratories, Inc., 1998-2011.

Todd, Victor H., *Protective Relays – their theory, design, and practical operation*, First Edition, Fourth Impression, McGraw-Hill Book Company, Inc., New York, 1922.

Appendix F

Version history

This is a list showing all significant additions, corrections, and other edits made to this learning module. Each entry is referenced by calendar date in reverse chronological order (newest version first), which appears on the front cover of every learning module for easy reference. Any contributors to this open-source document are listed here as well.

5 December 2024 – edited some instructor notes.

16 November 2024 – divided the Introduction chapter into sections, one with recommendations for students, one with a listing of challenging concepts, and one with recommendations for instructors.

2 May 2024 – added another fault scenario to consider on the “Faulted 50/51 system” Diagnostic Reasoning question.

7 December 2023 – added an introductory section to the Tutorial chapter, and also added photos showing a General Electric IAC 50 element close-up.

4 December 2023 – fixed a minor typographical error on quotation marks surrounding “IIT”.

25 July 2023 – added a new Quantitative Reasoning question challenging students to write a computer program predicting trip time for a 51 relay.

8 February 2023 – added a new Conceptual Reasoning question based on Westinghouse model CO-11 overcurrent relays.

28 November 2022 – placed questions at the top of the itemized list in the Introduction chapter prompting students to devise experiments related to the tutorial content.

8 May 2021 – commented out or deleted empty chapters.

27-28 April 2021 – significantly edited the Introduction chapter to make it more suitable as a pre-study guide and to provide cues useful to instructors leading “inverted” teaching sessions. Also added some Foundational Concepts and made a minor edit to image.0803.

18 April 2021 – added questions.

5 November 2018 – retitled Historical References section(s) so as to not be redundant to the “Historical References” chapter.

September 2018 – renamed “Derivations and Technical References” chapter to “Historical References”.

July 2018 – document first created.

Index

- 50 relay, instantaneous overcurrent protection, 8
- 51 relay, time overcurrent protection, 9

- Adding quantities to a qualitative problem, 54
- Annotating diagrams, 53

- Checking for exceptions, 54
- Checking your work, 54
- Code, computer, 61
- Coordination, 9, 17

- Definite time, 9
- Dimensional analysis, 53
- Drag magnet, 12

- Edwards, Tim, 62

- Graph values to solve a problem, 54
- Greenleaf, Cynthia, 27

- How to teach with these modules, 56
- Hwang, Andrew D., 63

- Identify given data, 53
- Identify relevant principles, 53
- Induction disk protective relay mechanism, 12
- Instantaneous overcurrent protection, 8
- Instructions for projects and experiments, 57
- Intermediate results, 53
- Inverted instruction, 56

- Knuth, Donald, 62

- Lampert, Leslie, 62
- Lenz's Law, 12
- Limiting cases, 54

- Maxwell, James Clerk, 21
- Metacognition, 32

- Microcontroller, 18
- Moolenaar, Bram, 61
- Murphy, Lynn, 27

- Open-source, 61

- Pickup current, protective relay, 11
- Pickup, protective relay, 8
- PLC, 18
- Problem-solving: annotate diagrams, 53
- Problem-solving: check for exceptions, 54
- Problem-solving: checking work, 54
- Problem-solving: dimensional analysis, 53
- Problem-solving: graph values, 54
- Problem-solving: identify given data, 53
- Problem-solving: identify relevant principles, 53
- Problem-solving: interpret intermediate results, 53
- Problem-solving: limiting cases, 54
- Problem-solving: qualitative to quantitative, 54
- Problem-solving: quantitative to qualitative, 54
- Problem-solving: reductio ad absurdum, 54
- Problem-solving: simplify the system, 53
- Problem-solving: thought experiment, 53
- Problem-solving: track units of measurement, 53
- Problem-solving: visually represent the system, 53
- Problem-solving: work in reverse, 54
- Programmable Logic Controller, 18

- Qualitatively approaching a quantitative problem, 54

- Reading Apprenticeship, 27
- Reductio ad absurdum, 54–56
- Relay test set, 18

- Schoenbach, Ruth, 27

Schweitzer Engineering Laboratories model SEL-
551 overcurrent relay, 17

Scientific method, 32

Seal-in contact, 13

Sensitivity, 17

Simplifying a system, 53

Socrates, 55

Socratic dialogue, 56

Solenoid coil, 10

SPICE, 27

Stallman, Richard, 61

Tap settings, 15, 24

Test set, relay, 18

Thought experiment, 53

Time dial, 16, 17, 23

Time lever, 23

Time overcurrent protection, 9

Torvalds, Linus, 61

Units of measurement, 53

Visualizing a system, 53

Work in reverse to solve a problem, 54

WYSIWYG, 61, 62