

DC circuit calculations

This worksheet and all related files are licensed under the Creative Commons Attribution License, version 1.0. To view a copy of this license, visit <http://creativecommons.org/licenses/by/1.0/>, or send a letter to Creative Commons, 559 Nathan Abbott Way, Stanford, California 94305, USA. The terms and conditions of this license allow for free copying, distribution, and/or modification of all licensed works by the general public.

Questions

Question 1

In a series circuit, certain general principles may be stated with regard to quantities of voltage, current, resistance, and power. Complete these sentences, each one describing a fundamental principle of series circuits:

“In a series circuit, voltage . . .”

“In a series circuit, current . . .”

“In a series circuit, resistance . . .”

“In a series circuit, power . . .”

For each of these rules, explain *why* it is true.

[file i01140](#)

Question 2

Explain, step by step, how to calculate the amount of current (I) that will go through each resistor in this series circuit, and also the current (I) supplied by the DC voltage source:

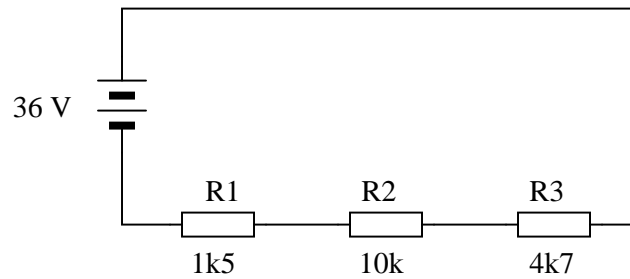

[file i01236](#)

Question 3

Determine the amount of voltage dropped by each resistor in this circuit, if each resistor has a color code of Brn, Blk, Red, Gld (assume perfectly precise resistance values – 0% error):

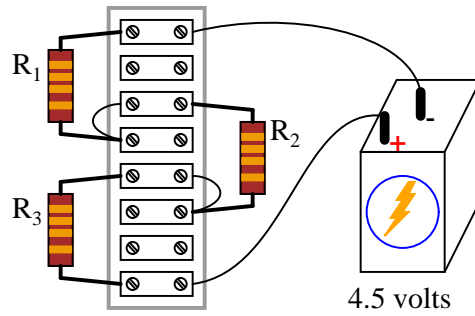

Also, determine the following information about this circuit:

- Current through each resistor
- Power dissipated by each resistor
- Ratio of each resistor's voltage drop to battery voltage ($\frac{E_R}{E_{bat}}$)
- Ratio of each resistor's resistance to the total circuit resistance ($\frac{R}{R_{total}}$)

[file i01181](#)

Question 4

Calculate the output voltages of these two voltage divider circuits (V_A and V_B):

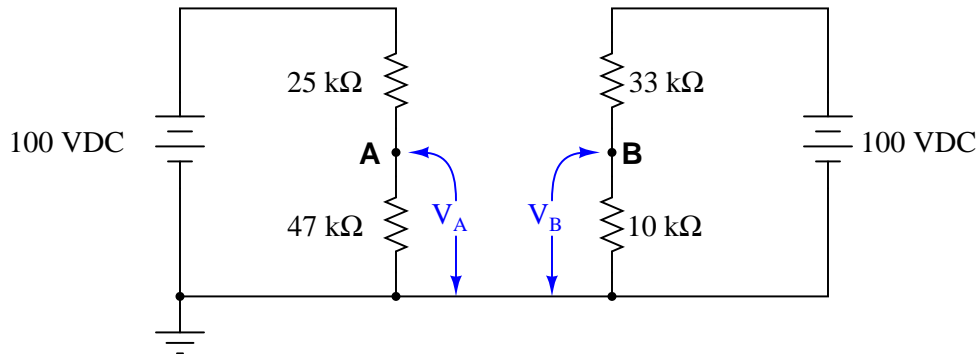

Now, calculate the voltage between points **A** (red lead) and **B** (black lead) (V_{AB}).

[file i01238](#)

Question 5

Calculate both the maximum and the minimum amount of voltage obtainable from this potentiometer circuit (as measured between the wiper and ground):

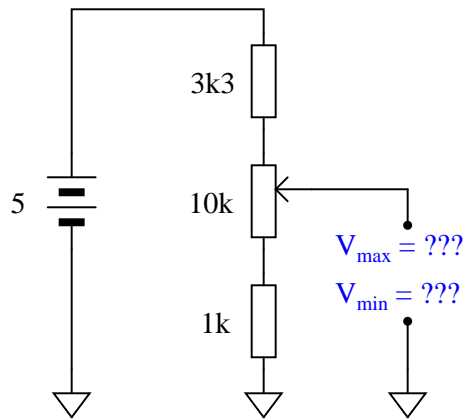

[file i01131](#)

Question 6

Suppose that an electric heater, which is nothing more than a large resistor, dissipates 500 watts of power when directly connected to a 110 volt source:

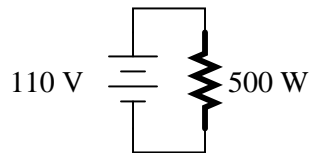

Now suppose that exact same heater is connected to one end of a long two-wire cable, which is then connected to the same 110 volt source. Assuming that each conductor within the cable has an end-to-end resistance of 3 ohms, how much power will the heater dissipate?

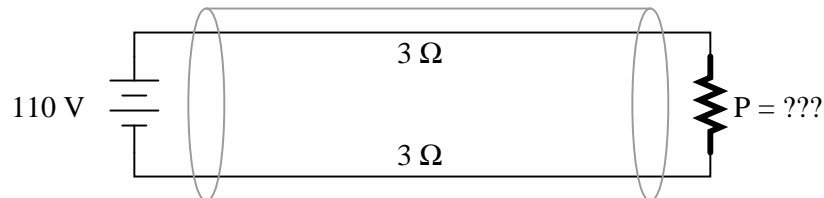

[file i01139](#)

Question 7

Suppose an analog voltmeter has a range of 0 to 10 volts, and an internal resistance of exactly 100 k Ω :

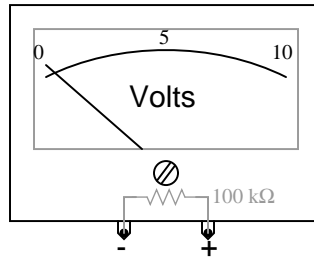

Show how a single resistor could be connected to this voltmeter to extend its range to 0 to 50 volts. Calculate the resistance of this “range” resistor, as well as its necessary power dissipation rating.

[file i01138](#)

Question 8

Determine the voltages registered by a voltmeter between the following points in this circuit. Be sure to note whether the voltmeter’s indication will be a positive value or a negative value in each case:

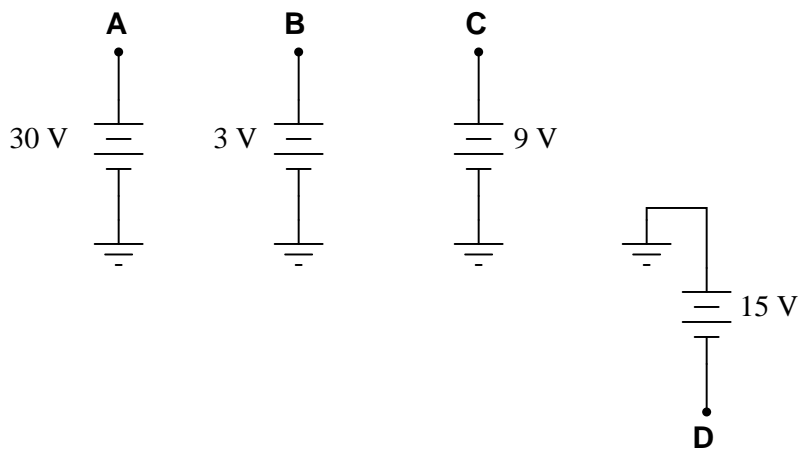

$V_A = \underline{\hspace{2cm}}$ (red lead on **A**, black lead on ground)

$V_B = \underline{\hspace{2cm}}$ (red lead on **B**, black lead on ground)

$V_C = \underline{\hspace{2cm}}$ (red lead on **C**, black lead on ground)

$V_D = \underline{\hspace{2cm}}$ (red lead on **D**, black lead on ground)

$V_{AC} = \underline{\hspace{2cm}}$ (red lead on **A**, black lead on **C**)

$V_{DB} = \underline{\hspace{2cm}}$ (red lead on **D**, black lead on **B**)

$V_{BA} = \underline{\hspace{2cm}}$ (red lead on **B**, black lead on **A**)

$V_{BC} = \underline{\hspace{2cm}}$ (red lead on **B**, black lead on **C**)

$V_{CD} = \underline{\hspace{2cm}}$ (red lead on **C**, black lead on **D**)

[file i02520](#)

Question 9

Calculate the amount of voltage between test points TP1 and TP3, and also the amount of voltage between test points TP2 and TP4:

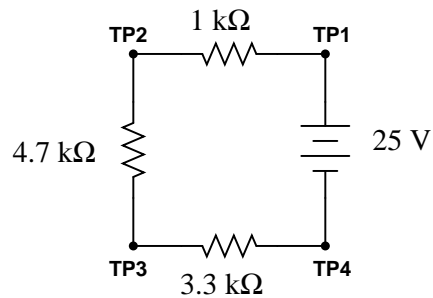

$$V_{TP1-TP3} = \quad V_{TP2-TP4} =$$

[file i01157](#)

Question 10

In a parallel circuit, certain general principles may be stated with regard to quantities of voltage, current, resistance, and power. Complete these sentences, each one describing a fundamental principle of parallel circuits:

“In a parallel circuit, voltage . . .”

“In a parallel circuit, current . . .”

“In a parallel circuit, resistance . . .”

“In a parallel circuit, power . . .”

For each of these rules, explain *why* it is true.

[file i01150](#)

Question 11

Use Kirchhoff's Current Law to calculate the magnitude and direction of the current through resistor R_4 in this resistor network:

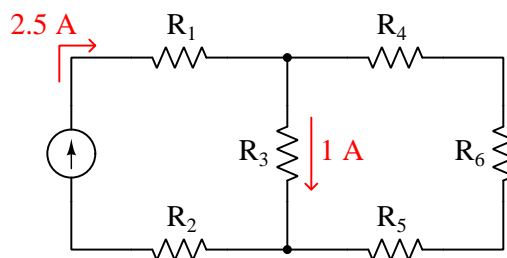

Note: all current arrows point in the direction of conventional flow!

[file i01161](#)

Question 12

Explain, step by step, how to calculate the amount of current (I) that will go through each resistor in this parallel circuit, and also the current (I) supplied by the DC voltage source:

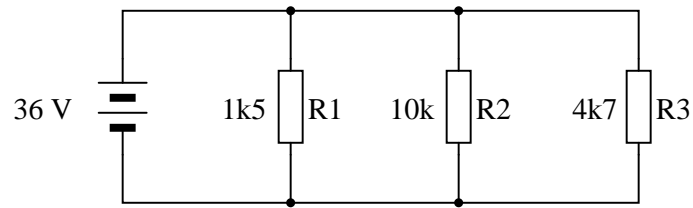

[file i01237](#)

Question 13

Calculate the total amount of current that the battery must supply to this parallel circuit:

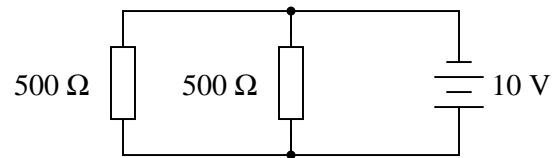

Now, using Ohm's Law, calculate total resistance (R_{total}) from total (source) voltage V_{total} and total (source) current I_{total} .

[file i01149](#)

Question 14

Complete the table of values for this circuit:

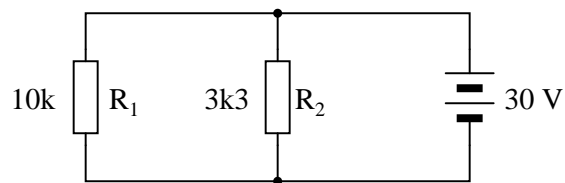

	R_1	R_2	Total
V			
I			
R			
P			

[file i01148](#)

Question 15

Complete the table of values for this circuit:

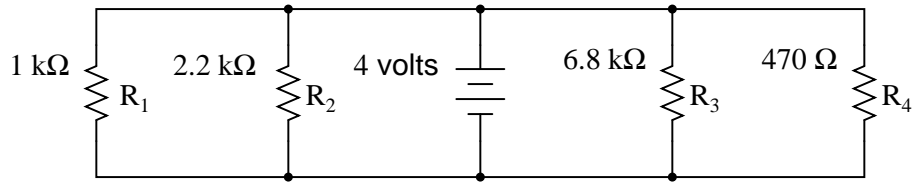

	R_1	R_2	R_3	R_4	Total
V					
I					
R	1 k Ω	2.2 k Ω	6.8 k Ω	470 Ω	
P					

[file i01146](#)

Question 16

The circuit shown here is commonly referred to as a *current divider*. Calculate the voltage dropped across each resistor, the current drawn by each resistor, and the total amount of electrical resistance “seen” by the 9-volt battery:

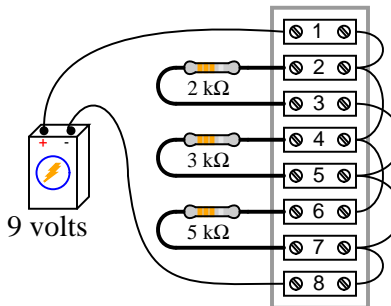

- Current through the 2 k Ω resistor =
- Current through the 3 k Ω resistor =
- Current through the 5 k Ω resistor =
- Voltage across each resistor =
- R_{total} =

[file i01147](#)

Question 17

Examine these two variable-resistance (*rheostat*) networks, each one with a large-range potentiometer and a small-range potentiometer:

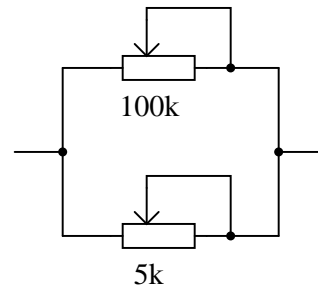
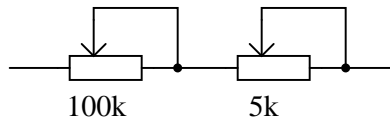

For each network, determine which pot is the *coarse* adjustment and which pot is the *fine* adjustment for total network resistance, and explain your reasoning.

Suggestions for Socratic discussion

- A good problem-solving technique is to perform a “thought experiment” on the given system. Here, determine the effect on total network resistance while each potentiometer (one at a time) is adjusted through its entire range while the other potentiometer is left in its mid-position.

[file i03144](#)

Question 18

Identify which of these components are connected directly in series with each other, and which are connected directly in parallel with each other:

Figure 1

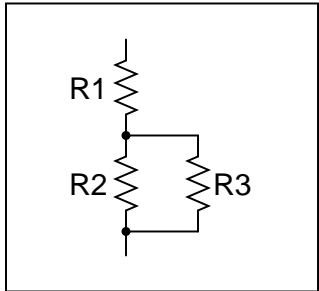

Figure 2

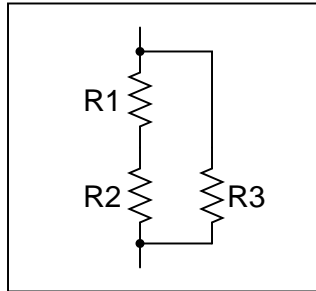

Figure 3

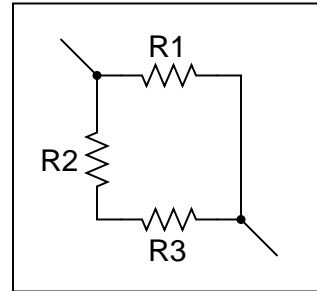

Figure 4

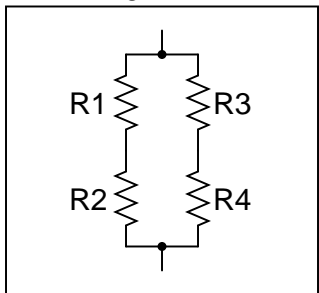

Figure 5

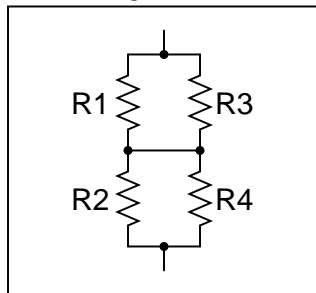
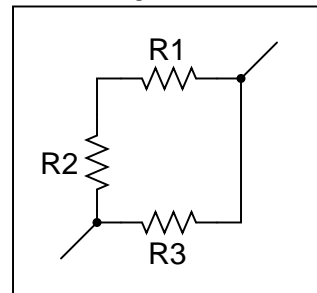

Figure 6



Assume that the open wire ends are connection points to a power source.

[file i01163](#)

Question 19

Identify which of these components are connected directly in series with each other, and which are connected directly in parallel with each other:

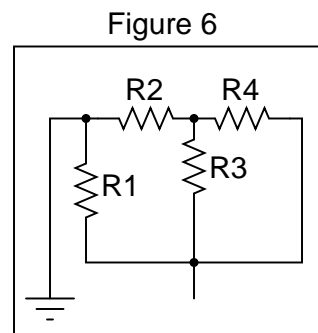
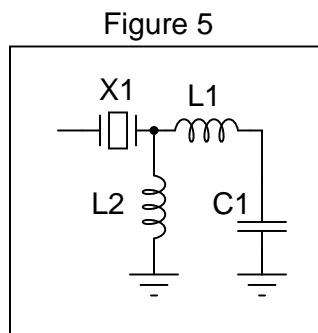
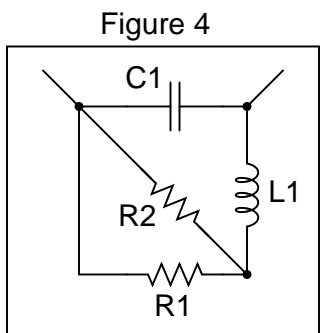
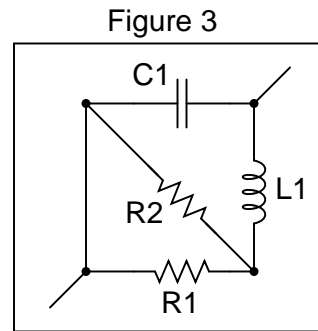
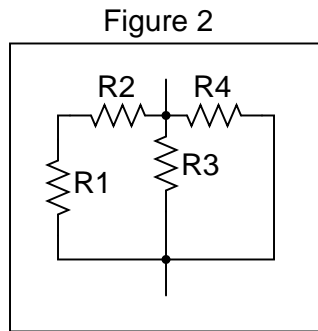
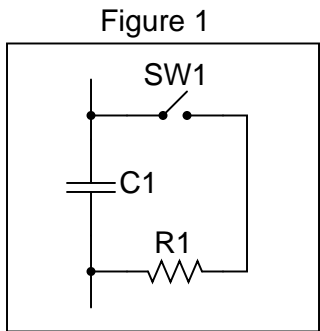

Assume that the open wire ends are connection points to a power source. In circuits where ground symbols appear, consider ground as the other side of the power source.

[file i01164](#)

Question 20

Calculate the resistance between points **A** and **B** (R_{AB}) for the following resistor networks:

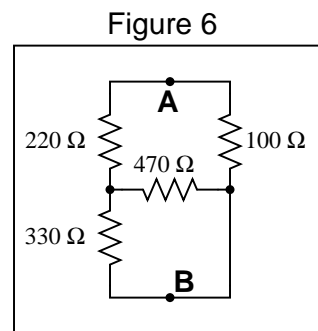
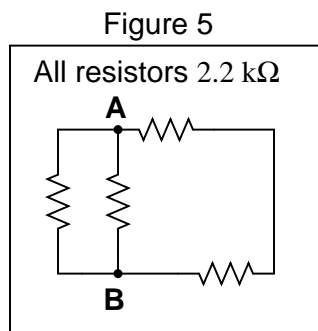
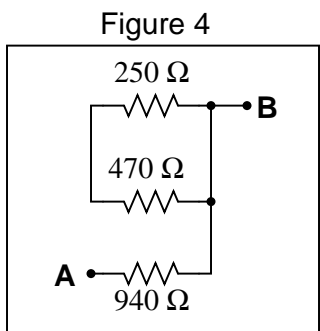
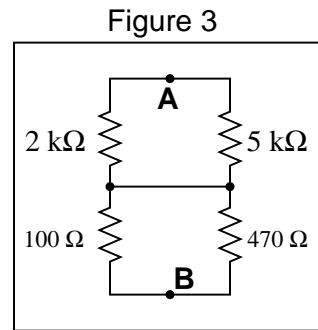
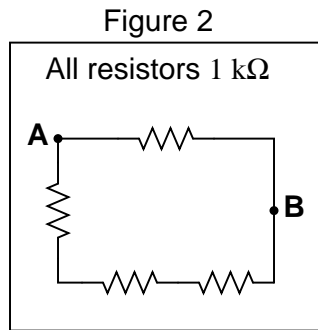
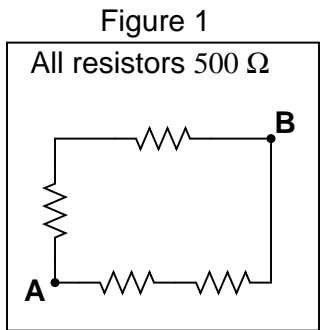

[file i01165](#)

Question 21

Use Kirchhoff's Voltage Law to calculate the magnitude and polarity of the voltage across resistors R_2 and R_4 in this resistor network:

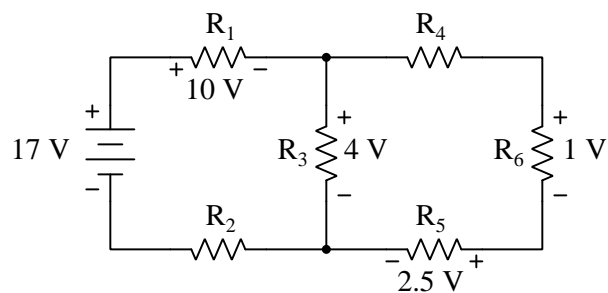

[file i01156](#)

Question 22

Imagine you are using a digital voltmeter to measure voltages between pairs of points in a circuit, following the sequence of steps shown in the following diagrams:

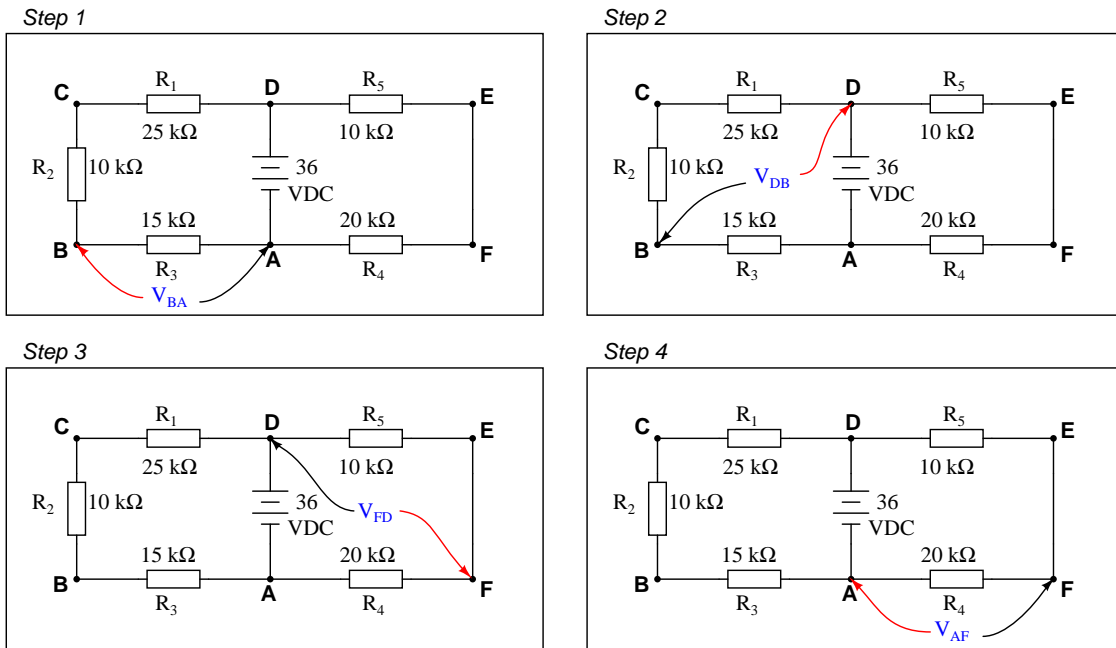

How much voltage would be registered by the voltmeter in each of the steps? Be sure to include the sign of the DC voltage measured (note the coloring of the voltmeter leads, with the red lead always on the first point denoted in the subscript: V_{BA} = red lead on “B” and black lead on “A”):

- V_{BA} =
- V_{DB} =
- V_{FD} =
- V_{AF} =

What is the algebraic sum of these voltages?

[file i01158](#)

Question 23

Calculate the amount of voltage dropped across resistor R_2 :

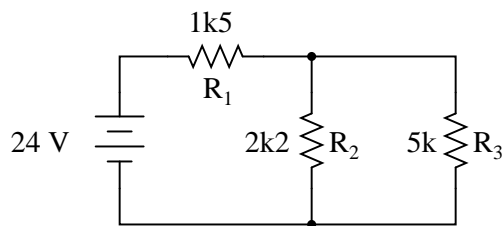

Also, note the direction of current through it and the polarity of the voltage drop across it.

[file i01166](#)

Question 24

Complete the table of values for this circuit:

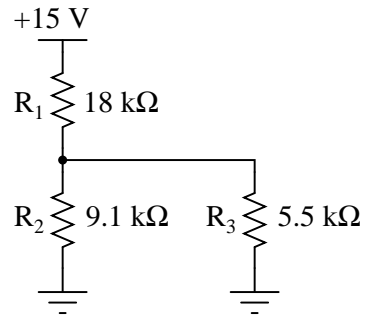

	R_1	R_2	R_3	Total
V				
I				
R	$18\text{ k}\Omega$	$9.1\text{ k}\Omega$	$5.5\text{ k}\Omega$	
P				

file i01169

Question 25

Suppose you were designing a circuit that required two LEDs for “power on” indication. The power supply voltage is 15 volts, and each LED is rated at 1.6 volts and 20 mA. Calculate the dropping resistor sizes and power ratings:

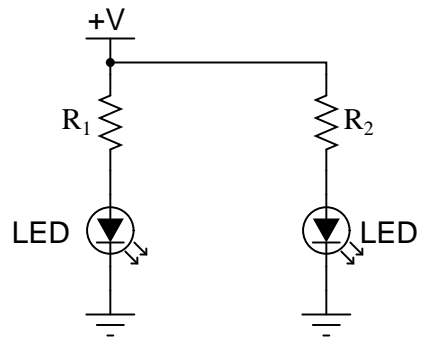

After doing this, a co-worker looks at your circuit and suggests a modification. Why not use a single dropping resistor for both LEDs, economizing the number of components necessary?

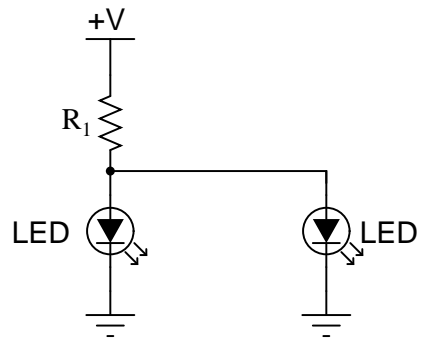

Re-calculate the dropping resistor ratings (resistance *and* power) for the new design.
[file i01170](#)

Question 26

Calculate the current through the zener diode for the given values of input (source) voltage in this circuit:

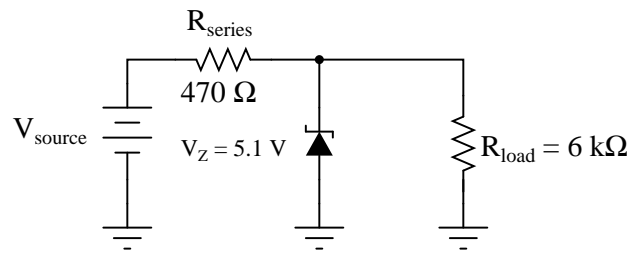

- $V_{source} = 25 \text{ V}$; $I_{zener} =$
- $V_{source} = 20 \text{ V}$; $I_{zener} =$
- $V_{source} = 15 \text{ V}$; $I_{zener} =$
- $V_{source} = 10 \text{ V}$; $I_{zener} =$
- $V_{source} = 5 \text{ V}$; $I_{zener} =$

Do you see any relationship between source voltage and zener diode current? If so, explain what that relationship is.

[file i00757](#)

Question 27

Complete the table of values for this circuit:

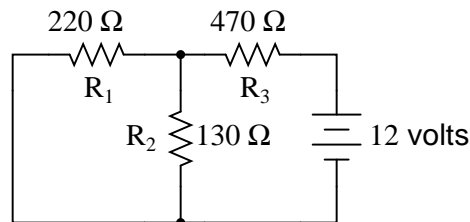

	R_1	R_2	R_3	Total
V				
I				
R	220 Ω	130 Ω	470 Ω	
P				

[file i01167](#)

Question 28

Complete the table of values for this circuit:

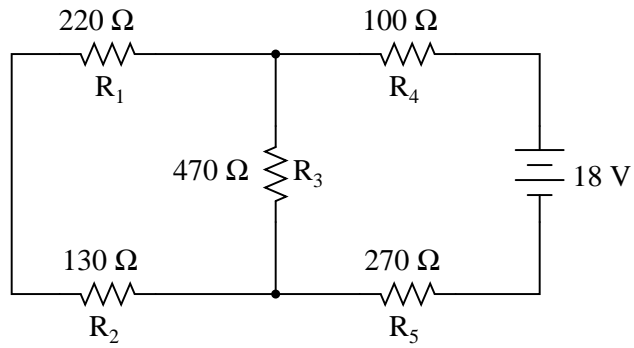

	R ₁	R ₂	R ₃	R ₄	R ₅	Total
V						
I						
R	220 Ω	130 Ω	470 Ω	100 Ω	270 Ω	
P						

[file i01176](#)

Question 29

Complete the table of values for this circuit:

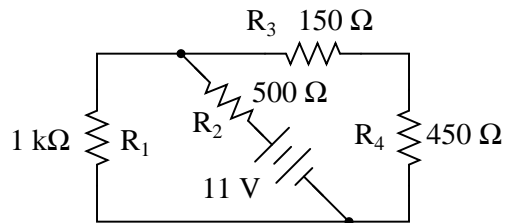

	R ₁	R ₂	R ₃	R ₄	Total
V					11 V
I					
R	1 kΩ	500 Ω	150 Ω	450 Ω	
P					

[file i01177](#)

Question 30

Calculate the amount of voltage between points **A** and **B** in this circuit. You must sketch polarity marks (+ , -) on the schematic diagram to show the polarity of V_{AB} , as well as show all of your mathematical work!

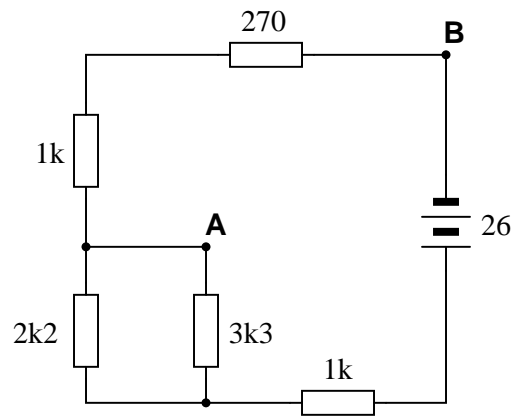

[file i02527](#)

Question 31

Complete the table of values for this circuit:

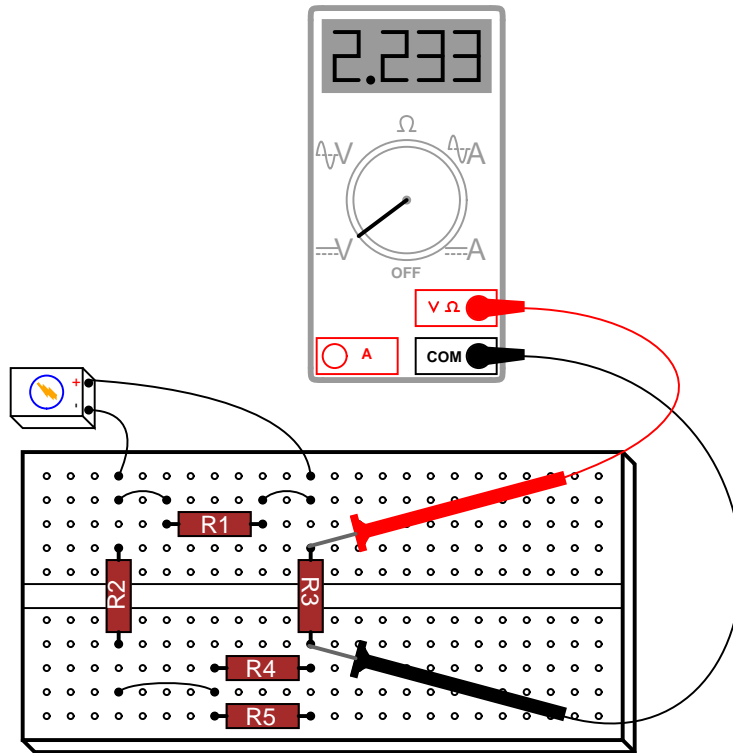

	R ₁	R ₂	R ₃	R ₄	R ₅	Total
V						
I						
R	2 kΩ	1 kΩ	3.3 kΩ	4.7 kΩ	4.7 kΩ	
P						

file i01179

Question 32

When the $5\text{ k}\Omega$ potentiometer in this circuit is set to its 0%, 25%, 50%, 75%, and 100% positions, the following output voltages are obtained (measured with respect to ground, of course):

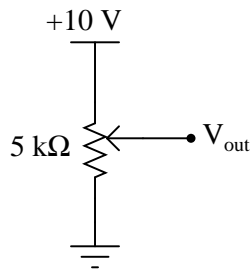

- At 0% setting, $V_{out} = 0\text{ V}$
- At 25% setting, $V_{out} = 2.5\text{ V}$
- At 50% setting, $V_{out} = 5\text{ V}$
- At 75% setting, $V_{out} = 7.5\text{ V}$
- At 100% setting, $V_{out} = 10\text{ V}$

Calculate what the output voltages will be if a $1\text{ k}\Omega$ load resistor is connected between the “ V_{out} ” terminal and ground:

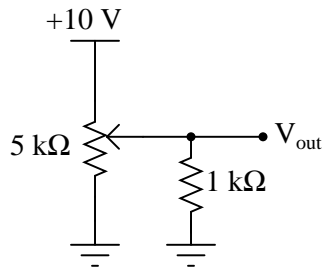

- At 0% setting, $V_{out} =$
- At 25% setting, $V_{out} =$
- At 50% setting, $V_{out} =$
- At 75% setting, $V_{out} =$
- At 100% setting, $V_{out} =$

[file i01132](#)

Question 33

Determine the voltages (with respect to ground) at points **A** and **B** in this circuit under four different conditions: both loads off, load 1 on (only), load 2 on (only), and both loads on:

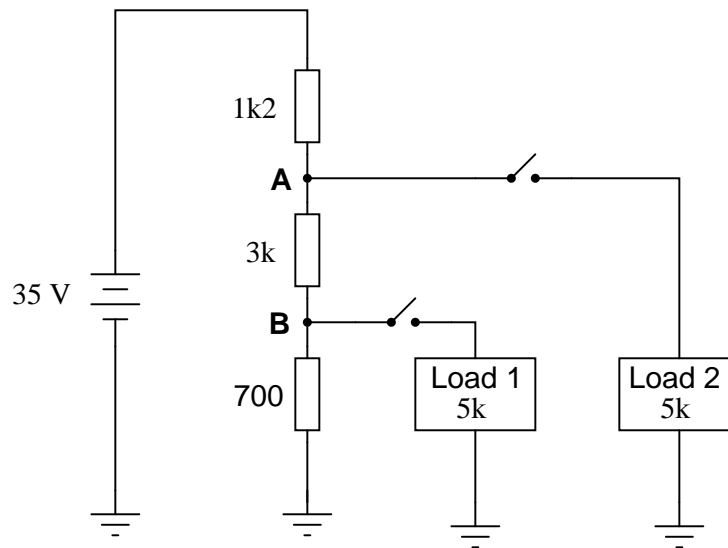

Voltage	Both loads off	Load 1 on (only)	Load 2 on (only)	Both loads on
V_A				
V_B				

file i01133

Question 34

One of the resistors in this voltage divider circuit is failed open. Based on the voltage readings shown at each load, determine which one it is:

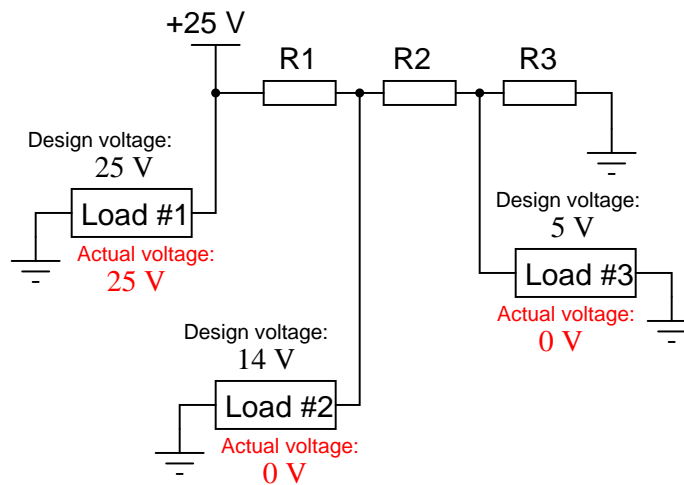

file i01134

Question 35

One of the resistors in this voltage divider circuit is failed open. Based on the voltage readings shown at each load, determine which one it is:

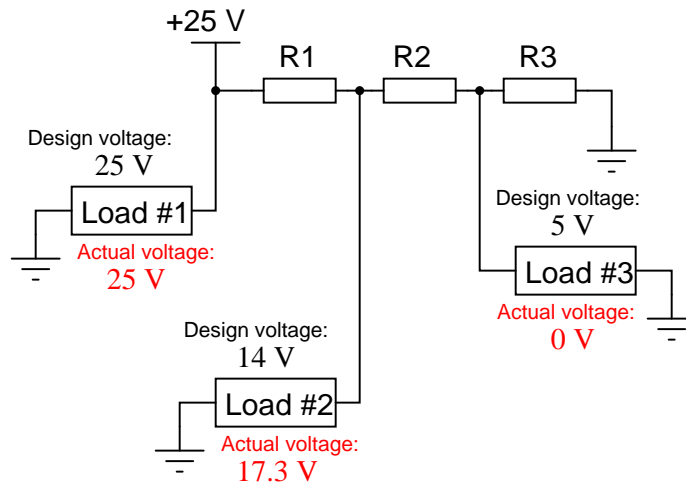

[file i01135](#)

Question 36

One of the resistors in this voltage divider circuit is failed (either open or shorted). Based on the voltage readings shown at each load, determine which one and what type of failure it is:

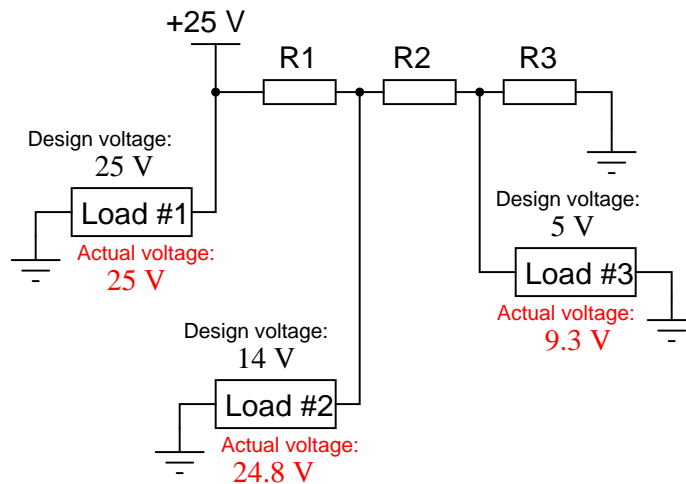

[file i01136](#)

Question 37

Old vacuum-tube based electronic circuits often required several different voltage levels for proper operation. An easy way to obtain these different power supply voltages was to take a single, high-voltage power supply circuit and “divide” the total voltage into smaller divisions.

These voltage divider circuits also made provision for a small amount of “wasted” current through the divider called a *bleeder* current, designed to discharge the high voltage output of the power supply quickly when it was turned off.

Design a high-voltage divider to provide the following loads with their necessary voltages, plus a “bleeder” current of 5 mA (the amount of current going through resistor R4):

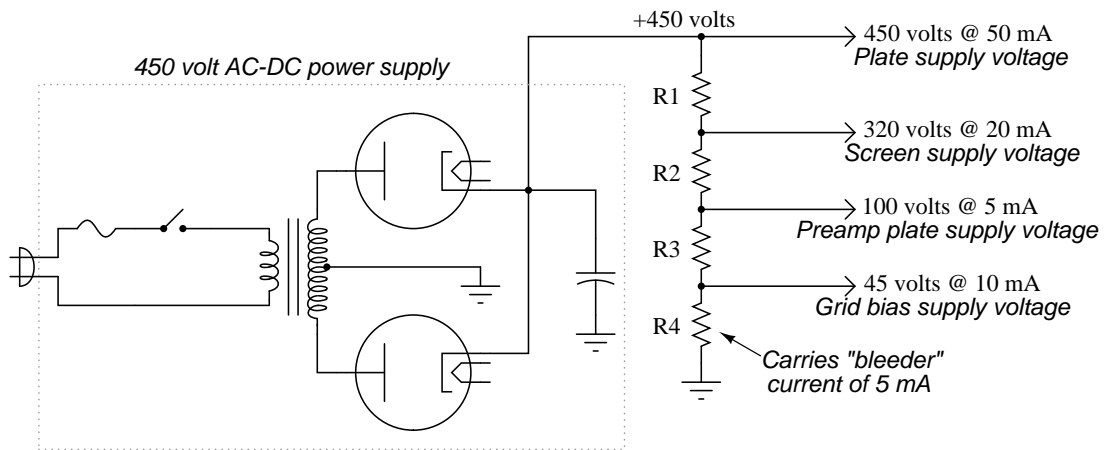

[file i01137](#)

Question 38

Calculate the necessary value of R to create a voltage drop of 4 volts between test points **A** and **B**:

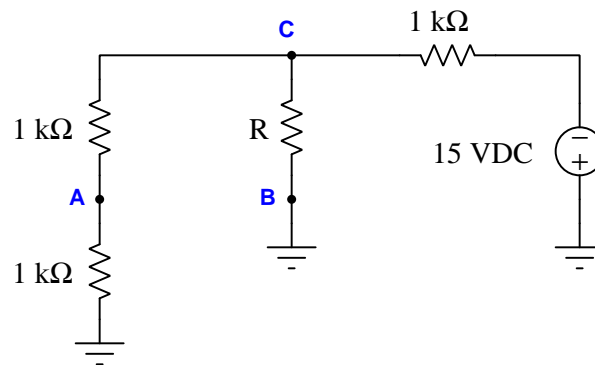

[file i01272](#)

Answer 1

“In a series circuit, voltage *drops add to equal the total.*”

This is an expression of Kirchhoff’s Voltage Law (KVL), whereby the algebraic sum of all voltages in any loop must be equal to zero.

“In a series circuit, current *is equal through all components.*”

This is true because a series circuit by definition has only one path for current to travel. Since charge carriers must move in unison or not at all (a consequence of the Conservation of Charge, whereby electric charges cannot be created or destroyed), the current measured at any one point in a series circuit must be the same as the current measured at any other point in that same circuit, at any given time.

“In a series circuit, resistances *add to equal the total.*”

Each resistance in a series circuit acts to oppose electric current. When resistances are connected in series, their oppositions combine to form a greater total opposition because then same current must travel through every resistance.

“In a series circuit, power *dissipations add to equal the total.*”

This is an expression of the Conservation of Energy, which states energy cannot be created or destroyed. Anywhere power is dissipated in any load of a circuit, that power must be accounted for back at the source, no matter how those loads might be connected to each other.

Answer 2

First we need to identify all the relevant principles for series circuits:

- The algebraic sum of all voltages in the circuit will be equal to zero (Kirchhoff's Voltage Law)
- Current is common throughout a series circuit, because there is only one path for current in the entire circuit
- Resistances add in series

We know the voltage of the source and the resistance of the three loads. However, we cannot simply apply Ohm's Law at this point because the source voltage is not impressed entirely on any one of the loads – rather the source voltage will be split up proportionately amongst the three loads in accordance with KVL. It is important to always apply Ohm's Law *in context*: $V = IR$ is true only if V , I , and R apply to the same component or set of components. Here, the 36 volts of the source applies to all three resistors, not to any one resistor.

However, we may apply the principle of resistances adding in series to arrive at a total resistance value for the circuit, which we may then apply to total voltage to find total current. Adding up the three resistors' values, we get a total resistance of $R_{total} = 1500 + 10000 + 4700 = 16200$ ohms. Total circuit current is then calculated as follows:

$$I = \frac{V}{R} = \frac{36 \text{ V}}{16200 \Omega} = 2.222 \text{ mA}$$

It is helpful to annotate all calculated values on the circuit schematic for easy reference. The reason this is helpful is because it applies a context to the calculated value. Here we will sketch arrows (in the direction of conventional flow) to document the 2.222 mA circuit current, based on the relationship between voltage and current for *sources* (i.e. current exits the positive pole of a source because the source is driving that current):

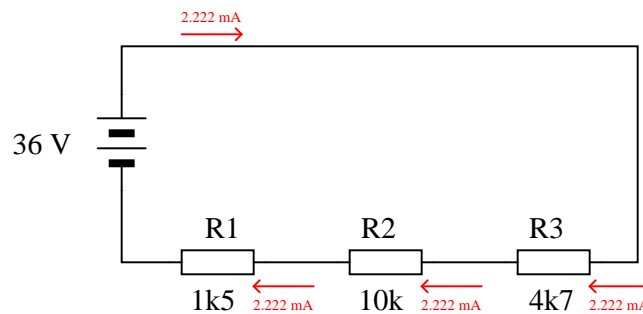

Since this is a series circuit, we know that this value of current (2.222 milliamps) will be common through all components. Now that we know the current through each resistor and the resistance of each resistor, we may apply Ohm's Law to each resistor individually as such:

$$V_{R1} = IR_1 = (2.222 \text{ mA})(1500 \Omega) = 3.333 \text{ V}$$

$$V_{R2} = IR_2 = (2.222 \text{ mA})(10000 \Omega) = 22.222 \text{ V}$$

$$V_{R3} = IR_3 = (2.222 \text{ mA})(4700 \Omega) = 10.444 \text{ V}$$

Once again it is recommended to annotate the circuit schematic with these calculated values, for the sake of keeping all calculations in context. The polarity (+ , -) of each voltage is important to note as well, and we know this by the relationship between voltage and current for *loads* (i.e. the positive pole of a load is the one where conventional flow enters, because the voltage dropped by a load is opposing current):

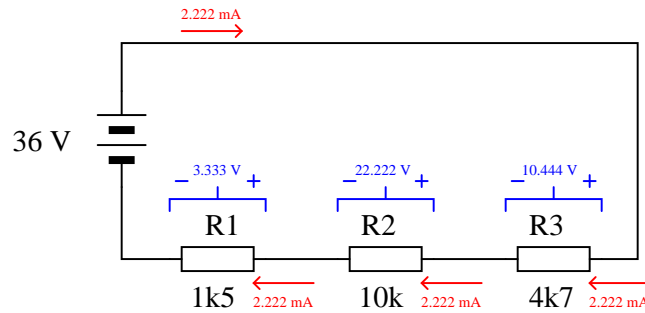

As a final check of our work, we may sum these three resistors' voltage drops to ensure they do indeed add up to equal the source voltage in accordance with KVL:

$$3.333 \text{ V} + 22.222 \text{ V} + 10.444 \text{ V} = 36 \text{ V}$$

Answer 3

Voltage across each resistor = 1.5 V

Current through each resistor = 1.5 mA

Power dissipated by each resistor = 2.25 mW

Voltage ratio = $\frac{1}{3}$

Resistance ratio = $\frac{1}{3}$

Answer 4

$V_A = + 65.28 \text{ V}$

$V_B = + 23.26 \text{ V}$

$V_{AB} = + 42.02 \text{ V}$ (point **A** being positive relative to point **B**)

Answer 5

$V_{max} = 3.85 \text{ volts}$

$V_{min} = 0.35 \text{ volts}$

Answer 6

$P = 321.1 \text{ watts}$

Answer 7

The basic problem here is how to make the voltmeter see 10 volts while it's being connected to a source with a value of 50 volts. This will require a *series* resistor to drop the extra 40 volts:

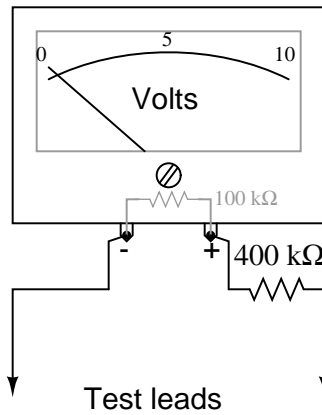

A power dissipation rating of $\frac{1}{8}$ watt would be more than sufficient for this application.

Answer 8

$V_A = \underline{+30 \text{ volts}}$ (red lead on **A**, black lead on ground)

$V_B = \underline{+3 \text{ volts}}$ (red lead on **B**, black lead on ground)

$V_C = \underline{+9 \text{ volts}}$ (red lead on **C**, black lead on ground)

$V_D = \underline{-15 \text{ volts}}$ (red lead on **D**, black lead on ground)

$V_{AC} = \underline{+21 \text{ volts}}$ (red lead on **A**, black lead on **C**)

$V_{DB} = \underline{-18 \text{ volts}}$ (red lead on **D**, black lead on **B**)

$V_{BA} = \underline{-27 \text{ volts}}$ (red lead on **B**, black lead on **A**)

$V_{BC} = \underline{-6 \text{ volts}}$ (red lead on **B**, black lead on **C**)

$V_{CD} = \underline{+24 \text{ volts}}$ (red lead on **C**, black lead on **D**)

Answer 9

$V_{TP1-TP3} = 15.83 \text{ volts}$ $V_{TP2-TP4} = 22.22 \text{ volts}$

Answer 10

“In a parallel circuit, voltage *is equal across all components.*”

This is true because a parallel circuit by definition is one where the constituent components all share the same two equipotential points.

“In a parallel circuit, currents *add to equal the total.*”

This is an expression of Kirchoff’s Current Law (KCL), whereby the algebraic sum of all currents entering and exiting a node must be equal to zero.

“In a parallel circuit, resistances *diminish to equal the total.*”

Each resistance in a parallel circuit provides another path for electric current. When resistances are connected in parallel, their combined total paths provide less opposition than any single path because the current is able to split up and proportionately follow these alternative paths.

“In a parallel circuit, power *dissipations add to equal the total.*”

This is an expression of the Conservation of Energy, which states energy cannot be created or destroyed. Anywhere power is dissipated in any load of a circuit, that power must be accounted for back at the source, no matter how those loads might be connected to each other.

Answer 11

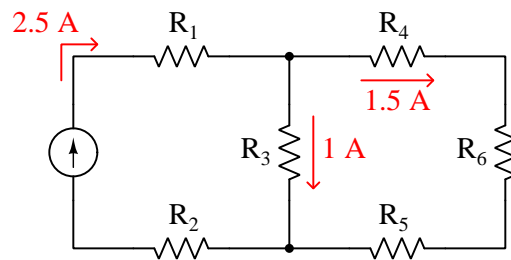

Note: all current arrows point in the direction of conventional flow!

First we need to identify all the relevant principles for series circuits:

- The algebraic sum of all currents at a node will be equal to zero (Kirchhoff's Current Law)
- Voltage is common throughout a parallel circuit, because every component shares the same two equipotential points
- Resistances diminish in parallel

Following from the rule that voltage is common throughout a parallel circuit, we may conclude that each of the three resistors sees 36 volts from the source. Thus, we may immediately apply Ohm's Law to calculate current through each of the resistors, knowing the voltage across each resistor and the resistance of each resistor:

$$I_{R1} = \frac{V}{R_1} = \frac{36 \text{ V}}{1500 \Omega} = 24 \text{ mA}$$

$$I_{R2} = \frac{V}{R_2} = \frac{36 \text{ V}}{10000 \Omega} = 3.6 \text{ mA}$$

$$I_{R3} = \frac{V}{R_3} = \frac{36 \text{ V}}{4700 \Omega} = 7.660 \text{ mA}$$

It is helpful to annotate all calculated values on the circuit schematic for easy reference. The reason this is helpful is because it applies a context to the calculated value. Here we will sketch arrows (in the direction of conventional flow) to document all three resistor currents, based on the relationship between voltage and current for *loads* (i.e. current enters the positive pole of a load because the load is opposing that current):

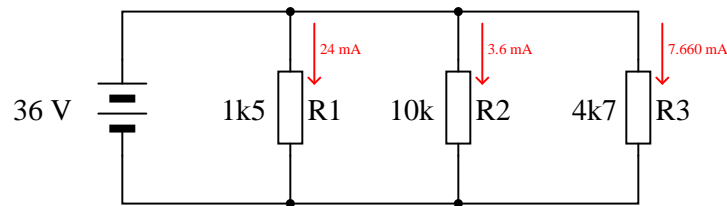

From here we may apply KCL to calculate current values at the each node, knowing that every milliamp leaving a node must be matched by a milliamp of current entering the node. Current entering the upper-right node, therefore, will be the sum of the two currents exiting that node. The same thing happens at the lower-right node, where two currents entering that node merge to form a larger current exiting:

$$I = 3.6 \text{ mA} + 7.660 \text{ mA} = 11.260 \text{ mA}$$

Once again we will document this calculated value on the circuit schematic to maintain its context:

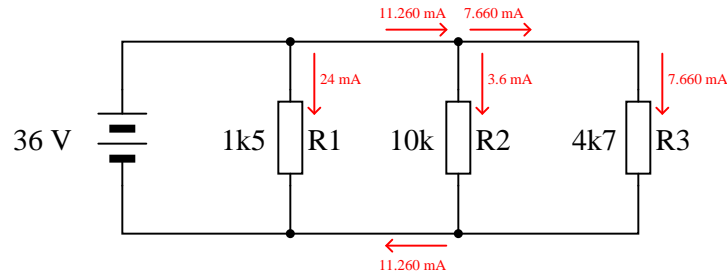

Applying KCL to the upper-left and lower-left nodes, and annotating the schematic once again:

$$I = 24 \text{ mA} + 11.260 \text{ mA} = 35.260 \text{ mA}$$

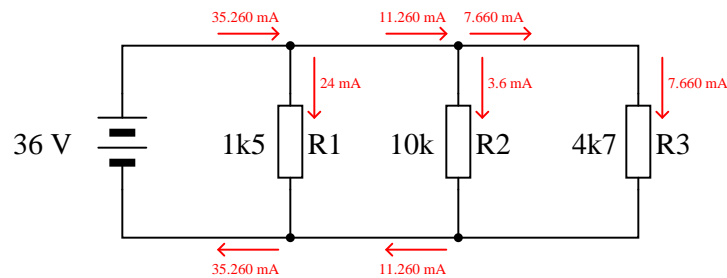

With the arrows showing this 35.260 mA current, we can see it passes straight out of (and back in to) the 36 volt source, which means this is our total current value for the parallel circuit.

Answer 13

$$I_{total} = 40.0 \text{ mA}$$

$$R_{total} = 250 \Omega$$

Answer 14

	R_1	R_2	Total
V	30 V	30 V	30 V
I	3 mA	9.09 mA	12.09 mA
R	10 k Ω	3.3 k Ω	2.481 k Ω
P	90 mW	272.7 mW	362.7 mW

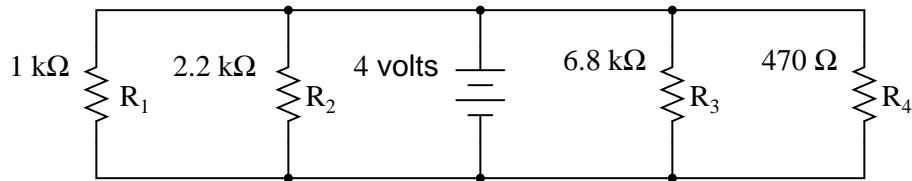

	R ₁	R ₂	R ₃	R ₄	Total
V	4 V	4 V	4 V	4 V	4 V
I	4 mA	1.82 mA	588.2 μA	8.51 mA	14.92 mA
R	1 kΩ	2.2 kΩ	6.8 kΩ	470 Ω	268.1 Ω
P	16 mW	7.27 mW	2.35 mW	34.0 mW	59.67 mW

- Current through the 2 kΩ resistor = 4.5 mA
- Current through the 3 kΩ resistor = 3 mA
- Current through the 5 kΩ resistor = 1.8 mA
- Voltage across each resistor = 9 volts
- $R_{total} = 967.74 \Omega$

Series network

100k = Coarse adjustment ; 5k = Fine adjustment

Parallel network

5k = Coarse adjustment ; 100k = Fine adjustment

General principles to keep in mind here are that series resistances *add* while parallel resistances *diminish*. The total resistance of a series network is always greater than any of its constituent resistances, and so the largest resistance in a series network tends to dominate. The total resistance of a parallel network is always less than any of its constituent resistances, and so the least resistance in a parallel network tends to dominate.

Answer 18

Figure 1:

R2 in parallel with R3.

Figure 2:

R1 in series with R2.

Figure 3:

R2 in series with R3.

Figure 4:

R1 in series with R2; R3 in series with R4.

Figure 5:

R1 in parallel with R3; R2 in parallel with R4.

Figure 6:

R1 in series with R2.

Answer 19

Figure 1:

R1 in series with SW1.

Figure 2:

R1 in series with R2; R3 in parallel with R4.

Figure 3:

R1 parallel with R2.

Figure 4:

R1 parallel with R2.

Figure 5:

L1 in series with C1.

Figure 6:

R3 in parallel with R4.

Answer 20

Figure 1:

$$R_{AB} = 500 \Omega$$

Figure 2:

$$R_{AB} = 750 \Omega$$

Figure 3:

$$R_{AB} = 1.511 \text{ k}\Omega$$

Figure 4:

$$R_{AB} = 940 \Omega$$

Figure 5:

$$R_{AB} = 880 \Omega$$

Figure 6:

$$R_{AB} = 80.54 \Omega$$

Answer 21

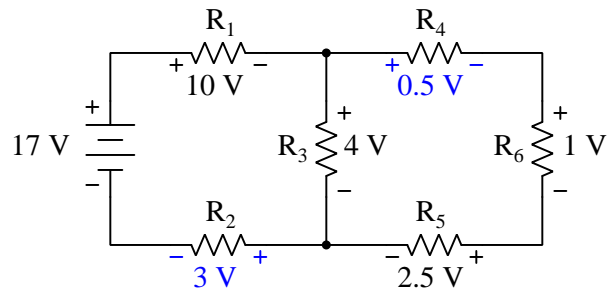

Answer 22

- $V_{BA} = +10.8$ volts
- $V_{DB} = +25.2$ volts
- $V_{FD} = -12.0$ volts
- $V_{AF} = -24.0$ volts

Answer 23

$V_{R2} = 12.11$ volts, positive on top and negative on bottom. If you follow conventional flow notation, this means current goes down through resistor R_2 . The actual flow of electrons through R_2 , however, is up.

Answer 24

	R_1	R_2	R_3	Total
V	12.6 V	2.4 V	2.4 V	15 V
I	700 μ A	263.7 μ A	436.3 μ A	700 μ A
R	18 k Ω	9.1 k Ω	5.5 k Ω	21.43 k Ω
P	8.82 mW	632.8 μ W	1.05 mW	10.5 mW

Answer 25

With two resistors: $R_1 = R_2 = 670 \Omega$, rated for at least 0.268 watts (1/2 watt would be a practical rating).

With one resistor: $R_1 = 335 \Omega$, rated for at least 0.536 watts (1 watt would be a practical rating).

Answer 26

As the source voltage decreases, zener diode current also decreases:

- $V_{source} = 25 \text{ V}$; $I_{zener} = 41.49 \text{ mA}$
- $V_{source} = 20 \text{ V}$; $I_{zener} = 30.85 \text{ mA}$
- $V_{source} = 15 \text{ V}$; $I_{zener} = 20.21 \text{ mA}$
- $V_{source} = 10 \text{ V}$; $I_{zener} = 9.58 \text{ mA}$
- $V_{source} = 5 \text{ V}$; $I_{zener} = 0 \text{ mA}$

It should be noted that the calculated answers shown here will *not* precisely match a real zener diode circuit, due to the fact that zener diodes tend to gradually taper off in current as the applied voltage nears the zener voltage rating rather than current sharply dropping to zero as a simpler model would predict.

Answer 27

	R_1	R_2	R_3	Total
V	1.778 V	1.778 V	10.22 V	12 V
I	8.079 mA	13.67 mA	21.75 mA	21.75 mA
R	220 Ω	130 Ω	470 Ω	551.7 Ω
P	14.36 mW	24.30 mW	222.3 mW	261.0 mW

Answer 28

	R_1	R_2	R_3	R_4	R_5	Total
V	3.978 V	2.351 V	6.328 V	3.155 V	8.517 V	18 V
I	18.08 mA	18.08 mA	13.46 mA	31.55 mA	31.55 mA	31.55 mA
R	220 Ω	130 Ω	470 Ω	100 Ω	270 Ω	570.6 Ω
P	71.92 mW	42.50 mW	85.21 mW	99.51 mW	268.7 mW	567.8 mW

Answer 29

	R_1	R_2	R_3	R_4	Total
V	4.714 V	6.286 V	1.179 V	3.536 V	11 V
I	4.714 mA	12.57 mA	7.857 mA	7.857 mA	12.57 mA
R	1 k Ω	500 Ω	150 Ω	450 Ω	875 Ω
P	22.22 mW	79.02 mW	9.26 mW	27.78 mW	138.3 mW

Answer 30

$V_{AB} = 9.198$ volts, **A** positive and **B** negative.

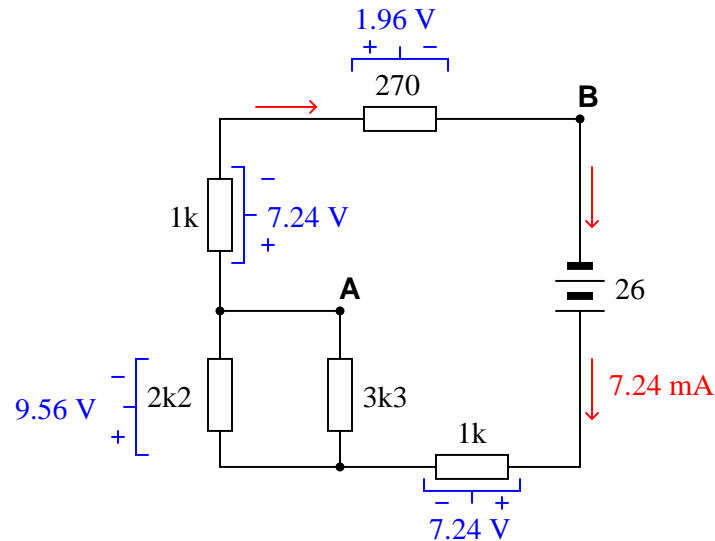

The voltage between points A and B is the supply voltage (26 volts) minus the voltage drops across the 1k and parallel subnetwork resistors. Alternatively, one could calculate V_{AB} by adding the voltage drops of the 1k and 270 ohm resistors.

The latter solution makes it easiest to see the polarity of V_{AB} : noting how the voltage drops across the 1k and 270 ohm resistors are additive, we see point A being the most positive and point B being the most negative.

Answer 31

	R_1	R_2	R_3	R_4	R_5	Total
V	4.500 V	676.6 mV	2.233 V	1.590 V	1.590 V	4.500 V
I	2.250 mA	676.7 μ A	676.7 μ A	338.3 μ A	338.3 μ A	2.927 mA
R	2 k Ω	1 k Ω	3.3 k Ω	4.7 k Ω	4.7 k Ω	1.538 k Ω
P	10.12 mW	457.9 μ W	1.511 mW	538.0 μ W	538.0 μ W	13.17 mW

Answer 32

- At 0% setting, $V_{out} = 0$ V
- At 25% setting, $V_{out} = 1.29$ V
- At 50% setting, $V_{out} = 2.22$ V
- At 75% setting, $V_{out} = 3.87$ V
- At 100% setting, $V_{out} = 10$ V

Answer 33

Voltage	Both loads off	Load 1 on (only)	Load 2 on (only)	Both loads on
V_A	26.4 volts	26.3 volts	22.4 volts	22.3 volts
V_B	5 volts	4.46 volts	4.23 volts	3.78 volts

Answer 34

Resistor R1 has failed open. This is evident because only load #1 is receiving any power; the other two loads are completely “dead”.

Answer 35

Resistor R2 has failed open. We can tell this because load #3 is receiving no power at all while load #2 is being over-powered.

Answer 36

Resistor R1 has failed (partially) shorted. We can tell this because both loads #2 and #3 are being over-powered.

Answer 37

The key to calculating all resistor values is to determine how much voltage each one must drop and how much current each one must carry. The current question may be answered by applying Kirchhoff's Current Law (KCL) to each of the nodes in the circuit, while the voltage question may be answered by calculating the voltage difference between each pair of supply lines to the tube circuit.

- $R_1 = 3.25$ k Ω
- $R_2 = 11$ k Ω
- $R_3 = 3.67$ k Ω
- $R_4 = 9$ k Ω

Answer 38

$$R = 2.667 \text{ k}\Omega$$