

NAME:

#	Question type	1st attempt	2nd attempt
1	Circuit sketching		
2-3	DC circuits		
4-5	Mathematics		
6	Circuit fault analysis		
7-8	AC and opamp circuits		
9-10	Relay and digital circuits		
--	Fractional score / Percentage score	Score = /	Score = %

No credit will be given for mathematical answers unless your work is shown!

**(1) Circuit sketching**

Sketch wires connecting components together to form one circuit where the red lamp is controlled by pushbutton switch “A” and the green lamp is controlled by pushbutton switch “B”. The control of each lamp should be independent (i.e. the status of one lamp should not affect the status of the other), and both lamps must share a common power source:

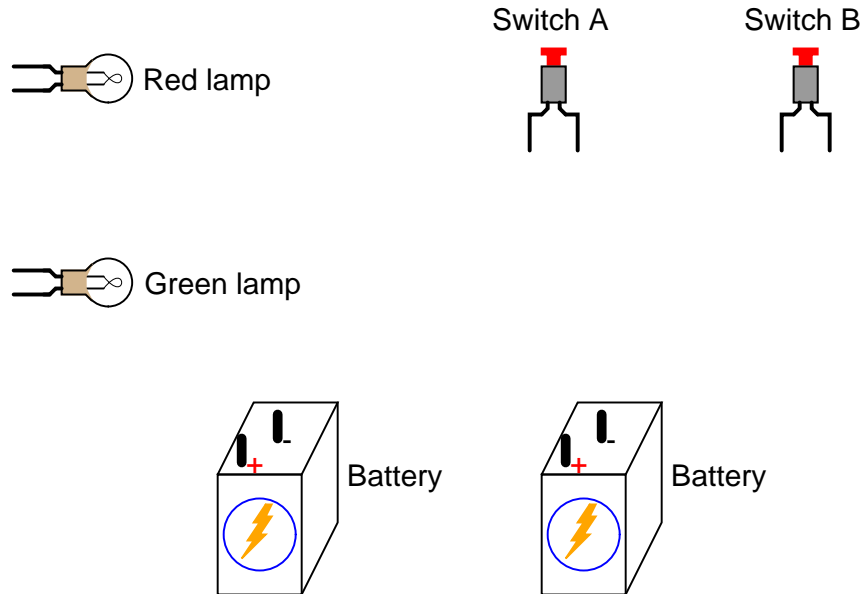

Assume each lamp is rated to operate at 12 volts with a current draw of 2.5 amps, and that each battery outputs 12 volts at a maximum current of 10 amps.

## (2) DC circuit analysis

In this circuit, a generator turned by an automobile engine provides electrical power to various loads in the automobile as well as current to re-charge the automobile's battery. The battery, of course, discharges when needed to provide additional current during "heavy" load conditions. The wires connecting these components together have small amounts of resistance as shown:

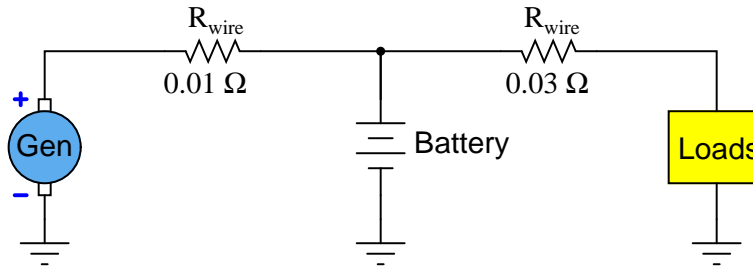

Supposing the generator's terminal voltage is 14.3 VDC, the battery is *charging* (i.e. acting as an electrical energy *load*) with a current of 2.7 amps, and the loads are drawing 12.4 amps of current, calculate the following:

$$V_{battery} =$$

$$V_{loads} =$$

## (3) DC capacitor/inductor circuit analysis

In this "boost" DC-DC converter circuit, a transistor is alternately switched on and off to control the storage and release of energy in an inductor, thus controlling the average voltage delivered to the load (which happens to be greater than the supply voltage):

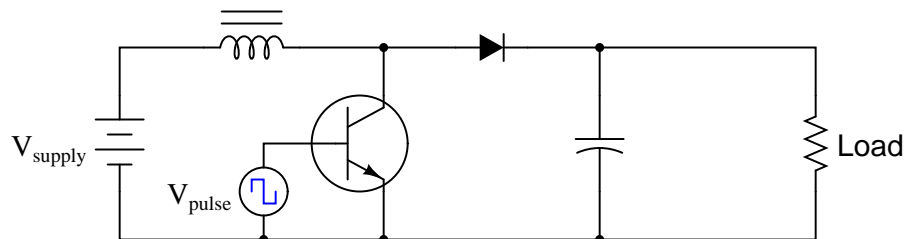

During the transistor's *on* period, sketch the following on the schematic diagram:

- Voltage polarity across the inductor (+ and - symbols)
- Voltage polarity across the diode (+ and - symbols)
- Direction of current through the capacitor (arrow pointing in the direction of conventional flow)

#### (4) Algebraic manipulation

The area of a *trapezoid* may be calculated using the following formula:

$$A = \frac{h}{2}(b + B)$$

Algebraically manipulate this formula to solve for  $b$ :

$$b =$$

#### (5) Trigonometry

Use the “current triangle” to calculate the phase shift angle ( $\theta$ ) between total current ( $I_{total}$ ) and resistor current ( $I_R$ ) in this parallel resistor-capacitor circuit, as well as the magnitude of  $I_{total}$ :

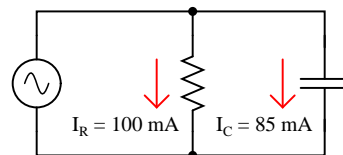
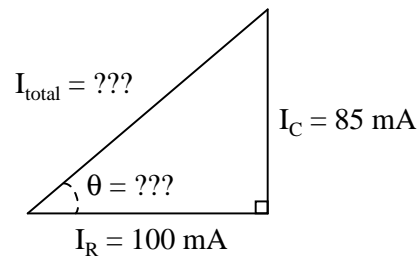

$$\theta =$$

$$I_{total} =$$

**(6) Circuit fault analysis**

Suppose the lamp refuses to light up regardless if the pushbutton switch is pressed or not. A voltmeter registers 0 volts between test points **F** and **B** in the circuit while the pushbutton is pressed:

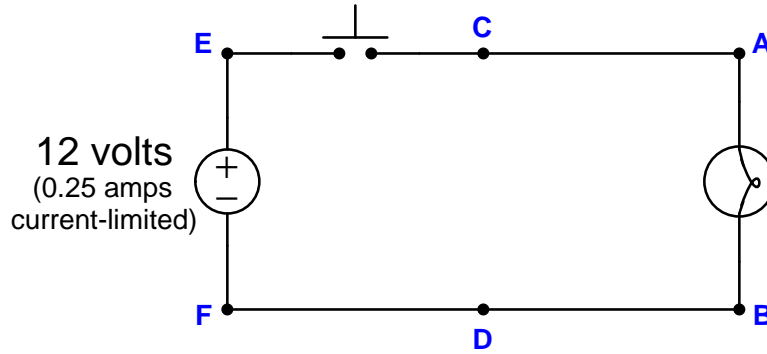

Identify the likelihood of each specified fault for this circuit. Consider each fault one at a time (i.e. no coincidental faults), determining whether or not each fault could independently account for *all* measurements and symptoms in this circuit.

Fault	Possible	Impossible
Open wire between A and C		
Open wire between B and D		
Open wire between D and F		
Lamp failed open		
Switch failed open		
Lamp failed shorted		
Switch failed shorted		
Voltage source dead		

**(7) AC circuit analysis**

Calculate the resistor current, and source current, and load power dissipation in this transformer circuit:

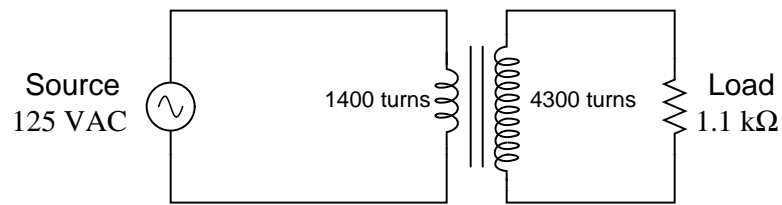

$I_R =$

$I_{source} =$

$P_{load} =$

**(8) Opamp circuit analysis**

Calculate the output voltage ( $V_{out}$ ) from this opamp circuit, given the voltage source values shown in the diagram. Assume the opamp is capable of "rail-to-rail" output voltage swings. Be sure to denote whether the output voltage is a positive or a negative value (with reference to ground):

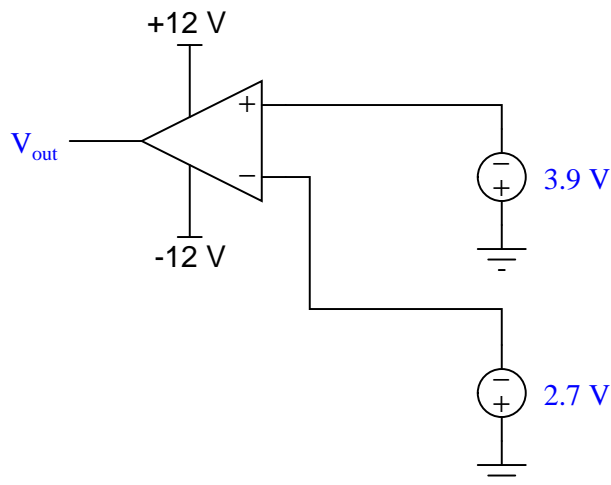

$V_{out} =$

**(9) Relay ladder logic circuit analysis**

Assess the status of this relay circuit, given the following (simultaneous) switch actuation statuses:

- Switch A = *pressed*
- Switch B = *pressed*
- Switch C = *unpressed*

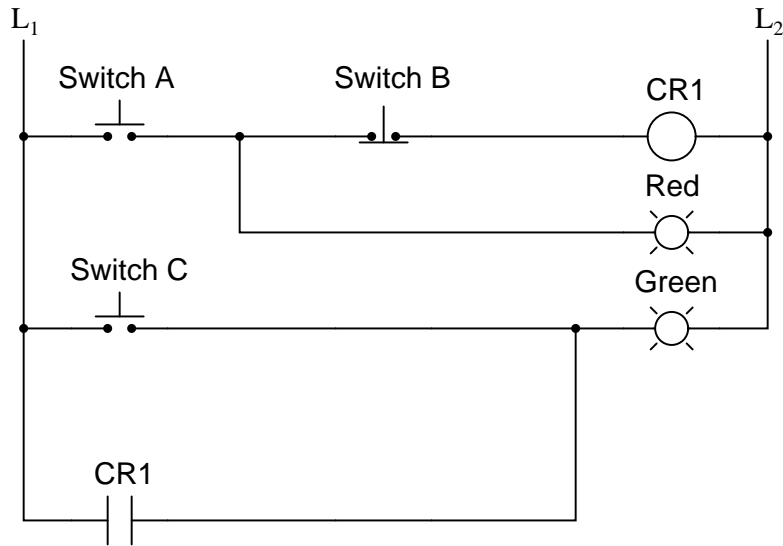

Now, check the appropriate cells in this table indicating whether each of the specified components is *energized* (powered) or *de-energized* (unpowered):

Component	Energized	De-energized
Red lamp		
Green lamp		
CR1 coil		

**(10) Semiconductor digital circuit analysis**

Determine the on/off state of the transistors within this TTL "NAND" logic gate, given the input switch states shown in the diagram:

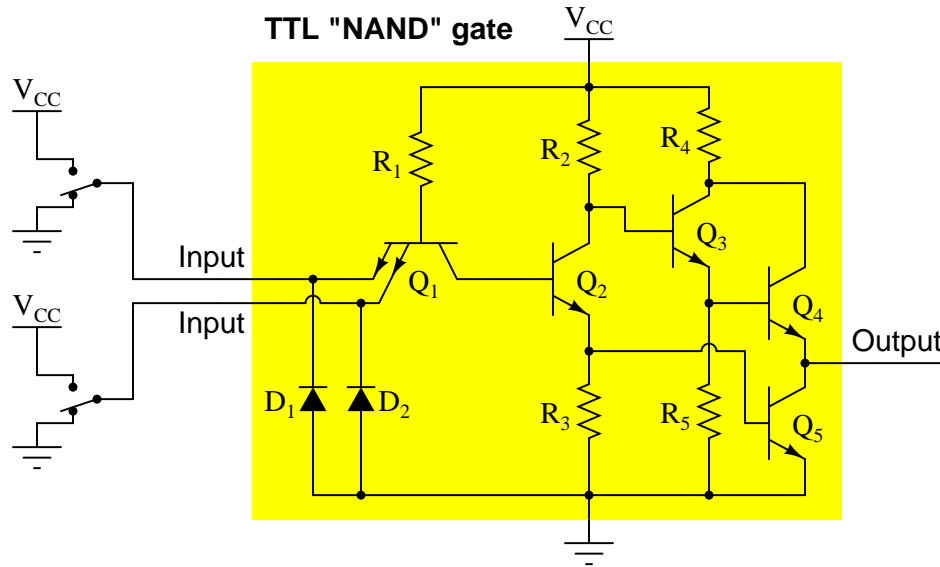

Place one check-mark in each row of the table, identifying the state of each transistor listed:

Transistor	On (conducting)	Off (non-conducting)
$Q_2$		
$Q_3$		
$Q_4$		
$Q_5$		

This page intentionally left blank



## Answers

### Answer 1

This is just one possible solution (note that it is not necessary to connect both batteries, since just one has enough current capacity to handle both loads):

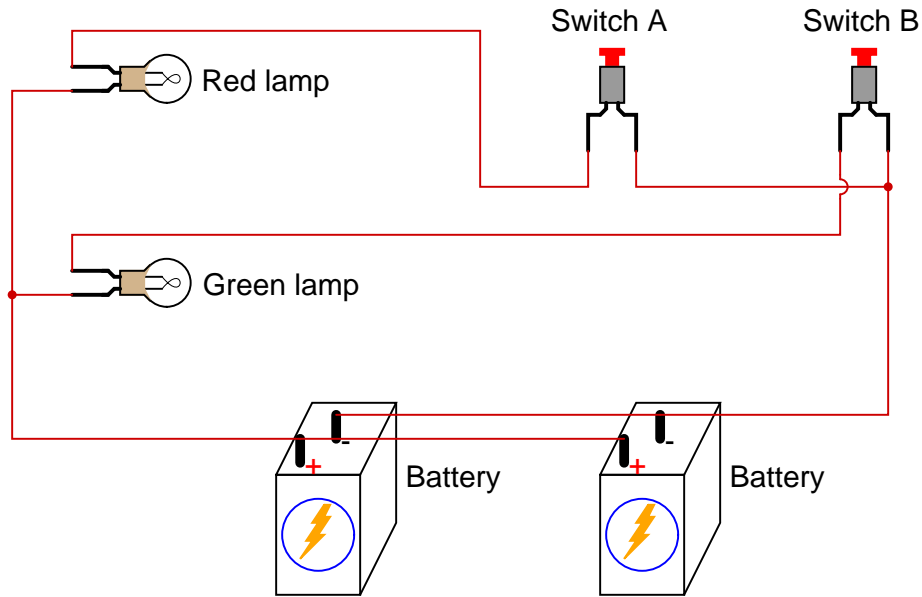

### Answer 2

$$V_{battery} = 14.149 \text{ volts}$$

$$V_{loads} = 13.777 \text{ volts}$$

### Answer 3

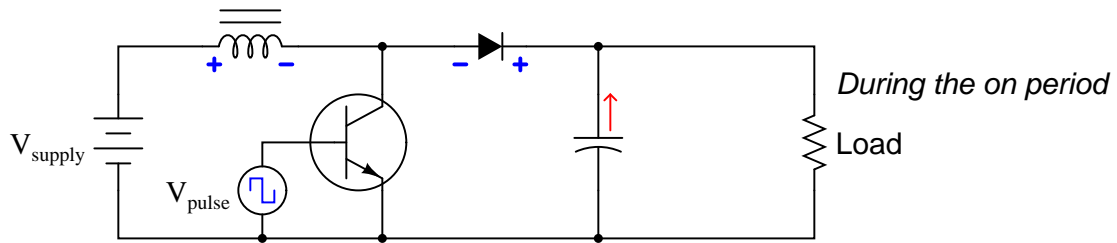

### Answer 4

$$b = \frac{2A}{h} - B$$

---

Answer 5

$$\theta = 40.36^\circ$$

$$I_{total} = 131.24 \text{ mA}$$

---

Answer 6

<b>Fault</b>	<b>Possible</b>	<b>Impossible</b>
Open wire between A and C	✓	
Open wire between B and D		✓
Open wire between D and F		✓
Lamp failed open	✓	
Switch failed open	✓	
Lamp failed shorted	✓	
Switch failed shorted		✓
Voltage source dead	✓	

---

Answer 7

$$I_R = 0.3490 \text{ amps}$$

$$I_{source} = 1.072 \text{ amps}$$

$$P_{load} = 134.0 \text{ watts}$$

---

Answer 8

$$V_{out} = -12 \text{ V}$$

---

Answer 9

<b>Component</b>	<b>Energized</b>	<b>De-energized</b>
Red lamp	✓	
Green lamp		✓
CR1 coil		✓

---

Answer 10

<b>Transistor</b>	<b>On (conducting)</b>	<b>Off (non-conducting)</b>
$Q_2$		✓
$Q_3$	✓	
$Q_4$	✓	
$Q_5$		✓

---