

BTC Instrumentation and Control Technology

Certification prep exam

This is a multiple-choice exam. Books and hand-written notes are allowed, as well as a scientific calculator. However, you may not reference old exams, course assignments, or other printed materials.

You are to choose the *best* answer for each question. This means there may be more than one answer which could be considered correct, but there will definitely be *one* answer that is better than all others.

It is strongly recommended that you do not change an answer unless you are absolutely sure it needs to be changed. If you feel unsure, leave your initial answer, because it is probably right.

A wrong answer counts the same as an unanswered question, so it pays to guess if you do not know the answer to a question.

This exam is an overview of concepts spanning the entire two-year stretch of the Instrumentation and Control Technology program. Unless you are just finishing the final quarter of this program, you will no doubt find some sections of the exam unfamiliar. Do not be concerned about this – simply do your best to answer all the questions.

The second page of this exam is a bubble-type answer sheet. When the exam time begins, you are to detach this sheet from the rest of the exam, write your name on this sheet, and also mark the quarters you have studied (**F**, **W**, **S** ; Fall, Winter, and Spring) in the Instrumentation and Control Technology program.

Question 1 – Industrial safety

The purpose of a lock-out/tag-out procedure is to:

- (A) Reduce time spent doing the job
- (B) Eliminate expenses related to maintenance
- (C) Prevent unauthorized personnel from entering an area
- (D) Secure all energy sources in a system
- (E) Reduce the risk of accidental fire

Question 2 – Industrial safety

A victim of electric shock may likely require what sort of immediate medical attention?

- (A) Bandages over the point of electrical contact
- (B) Ice applied to the burned areas
- (C) Antibiotics to prevent infection
- (D) CPR
- (E) An EEG test to record nervous system function

Question 3 – Industrial safety

The *very first* thing you should do if you are the first to witness or discover an accident on the job site is to:

- (A) Provide first-aid to the victim(s)
- (B) Seek the assistance of the nearest co-worker
- (C) Alert professional emergency responders
- (D) Report the incident to your supervisor
- (E) Cry like a baby

Question 4 – Industrial safety

The purpose of a cartridge-style respirator is to:

- (A) Provide a pure oxygen breathing environment where there is insufficient oxygen in the air
- (B) Enhance your personal appearance for maximum social appeal
- (C) Convert exhaled carbon dioxide back into oxygen for re-breathing
- (D) Reduce the concentration of particulates in the air you breathe
- (E) Reduce noxious odors in the air you breathe

Question 5 – Industrial safety

Shock is defined as an abnormal condition of the body where:

- (A) There is insufficient blood delivered to the body's cells
- (B) The heart stops beating normally, and “quivers” instead
- (C) The lungs are unable to process oxygen properly
- (D) A broken bone has penetrated the skin
- (E) The muscles in the body have “frozen” and will not move

Question 6 – Industrial safety

A *confined space* is deemed ready for employee entry when:

- (A) The unit operations foreman declares it ready
- (B) A company safety inspector has certified it
- (C) Your supervisor assigns you to the job
- (D) An independent inspection agency has completed their survey
- (E) An engineer has completed the necessary calculations

Question 7 – Industrial safety

One of the common signs of a heart attack is:

- (A) A sharp pain in the lower area of the spine
- (B) Loss of bowel control
- (C) A feeling of numbness in the legs
- (D) Discomfort in the chest and/or upper body
- (E) A general feeling of restlessness and anxiety

Question 8 – Industrial safety

Heat stroke is often indicated by the following symptoms:

- (A) Cold and clammy skin, thirst, vomiting, confusion
- (B) Hot and dry skin, inability to drink, vomiting, confusion
- (C) A sudden affinity for country-western music
- (D) Dizziness, vomiting, cold skin, profuse sweating
- (E) Blue-colored skin, extreme hunger, feelings of anxiety, thirst

Question 9 – Industrial safety

Arc blast is caused by:

- (A) Poor contact within electrical wire splices
- (B) Radio frequency emissions from high-power transmitters
- (C) Discharge of high electrical current through open air
- (D) Failure to lock-out and tag-out electrical breakers
- (E) Ionization of gases near high-voltage electrical conductors

Question 10 – Industrial safety

Current measurements are more dangerous to make with a multimeter than voltage measurements because:

- (A) You must use both hands to take the measurement
- (B) Most multimeters are unfused
- (C) The resulting magnetic fields may be very strong
- (D) The circuit must be broken (opened)
- (E) A fuse protects the voltage measurement ranges, but not current

Question 11 – Algebra

Manipulate the following equation to solve for x :

$$y = \frac{x}{ab}$$

- (A) $x = \frac{y}{ab}$
- (B) $x = \frac{ay}{b}$
- (C) $x = aby$
- (D) $x = \frac{a}{by}$
- (E) $x = \frac{ab}{y}$

Question 12 – Algebra

Manipulate the following equation to solve for x :

$$a = \sqrt{bx^2}$$

- (A) $x = \sqrt{ab}$
- (B) $x = \sqrt{\frac{a}{b}}$
- (C) $x = \left(\frac{a}{b}\right)^2$
- (D) $x = \frac{a^2}{b}$
- (E) $x = \frac{a}{\sqrt{b}}$

Question 13 – Algebra

Which of the following equations describes this graph?

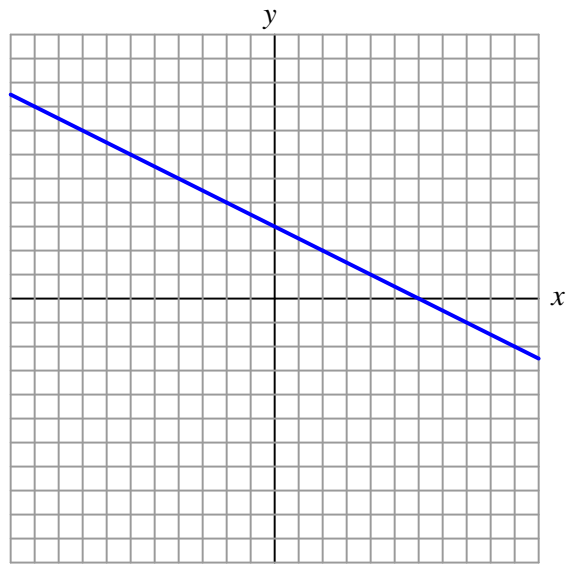

- (A) $y = x - \frac{1}{2}$
- (B) $y = x^2 - 3$
- (C) $y = -\frac{x}{2} + 3$
- (D) $y = \frac{1}{2}x + 3$
- (E) $y = 3 - 2x$

Question 14 – Algebra

Which of the following equations describes this graph?

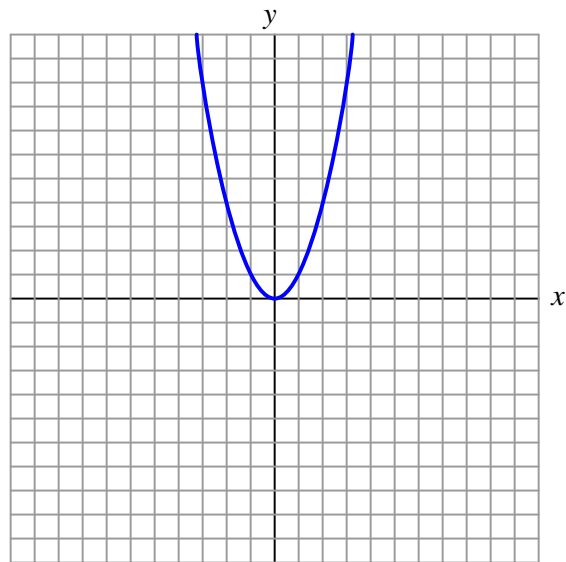

- (A) $y = \sqrt{x}$
- (B) $y = x^2$
- (C) $y = 2x$
- (D) $y = \sqrt[3]{x}$
- (E) $y = x^{-2}$

Question 15 – Algebra

Solve for both x and y in this simultaneous system of equations:

$$x + 3y = -1$$

$$4x - y = 9$$

- (A) $x = -1 ; y = 2$
- (B) $x = 1 ; y = 2$
- (C) $x = -2 ; y = 1$
- (D) $x = 2 ; y = 1$
- (E) $x = 2 ; y = -1$

Question 16 – Algebra

Which of the following ratios is equivalent to the ratio 25:300 ?

- (A) 15:4
- (B) 1:12
- (C) 15:1
- (D) 17:5
- (E) 5:17

Question 17 – Algebra

Simplify the following expression as much as possible:

$$\left(\frac{a^4b^{-2}c}{ab^2}\right)\left(\frac{x^2y^2c^2}{a^2b^3}\right)$$

- (A) $a^{-1}b^7c^2x^2y^2$
- (B) $(ab)^4c^3(xy)^4$
- (C) $a\sqrt{b^5}c^3x^4y^4$
- (D) $ab^{-7}c^3x^2y^2$
- (E) $a^2b^{-3}c^2x^2y^2$

Question 18 – Algebra

Select the equivalent expression:

$$\frac{1}{\sqrt{x^3}}$$

- (A) $2x^{-1/3}$
- (B) $x^{-3/2}$
- (C) $x^{3/2}$
- (D) $x^{2/3}$
- (E) $-\sqrt{x^3}$

Question 19 – Algebra

Calculate 27% of 340.

- (A) 88.8
- (B) 81.0
- (C) 91.8
- (D) 79.4
- (E) 12.6

Question 20 – Algebra

Factor the following polynomial expression:

$$x^2 - x - 12$$

- (A) $(x + 3)(x - 4)$
- (B) $(x + 12)(x - 1)$
- (C) $(x + 1)(x - 12)$
- (D) $(x + 4)(x - 3)$
- (E) $(x + 2)(x - 6)$

Question 21 – Trigonometry

The *sine* function is defined as ratio of side lengths,

- (A) Adjacent divided by hypotenuse
- (B) Opposite divided by adjacent
- (C) Opposite divided by hypotenuse
- (D) Adjacent divided by opposite
- (E) Hypotenuse divided by adjacent

Question 22 – Trigonometry

Calculate the length of side x in this right triangle:

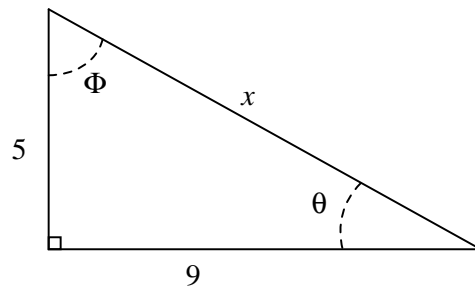

- (A) 10.3
- (B) 10.8
- (C) 9.43
- (D) 3.74
- (E) 4.00

Question 23 – Trigonometry

Calculate the angle Φ in this right triangle:

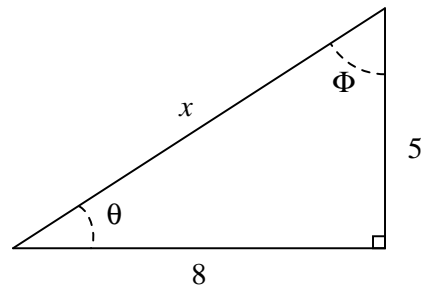

- (A) 57.99°
- (B) 38.68°
- (C) 51.32°
- (D) 1.012°
- (E) 64.44°

Question 24 – Trigonometry

Calculate the angle θ in this right triangle:

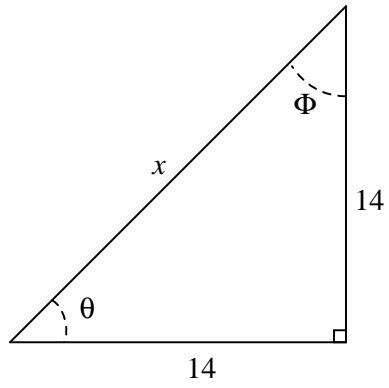

- (A) 19.80°
- (B) 50°
- (C) 45°
- (D) 14°
- (E) $\frac{\pi}{4}^\circ$

Question 25 – Trigonometry

A model rocket enthusiast wants to approximately measure the peak altitude of her rocket by measuring the angle from horizontal (θ) sighting the rocket at its apogee and the distance from the launch pad to the point of observation. Which trigonometric function will she need to use in order to calculate the rocket's height?

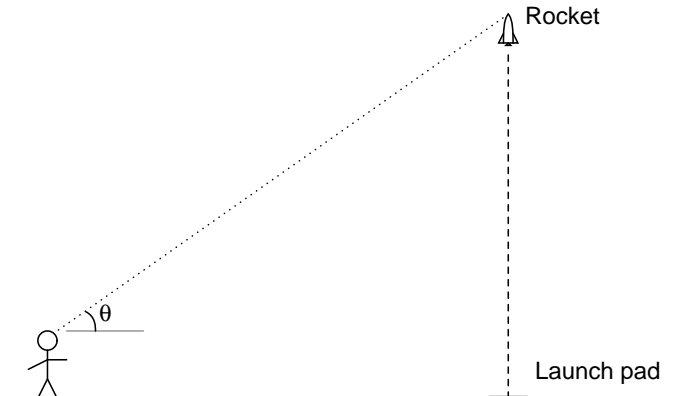

- (A) Cosine
- (B) Cosecant
- (C) Sine
- (D) Secant
- (E) Tangent

Question 26 – Trigonometry

Add these two complex numbers and express the sum in polar notation:

$$(5 - j3) + (-8 - j10)$$

- (A) $14.765 \angle 28.3^\circ$
- (B) $13.342 \angle -103^\circ$
- (C) $14.765 \angle 61.7^\circ$
- (D) $-3 + j13$
- (E) $18.385 \angle -45^\circ$

Question 27 – Trigonometry

Complex numbers are used in AC circuit analysis primarily to represent:

- (A) Frequency
- (B) Power
- (C) Bandwidth and harmonic content
- (D) Gain and attenuation factors
- (E) Amplitude and phase shift

Question 28 – Trigonometry

Calculate the length of side **A** in this non-right triangle:

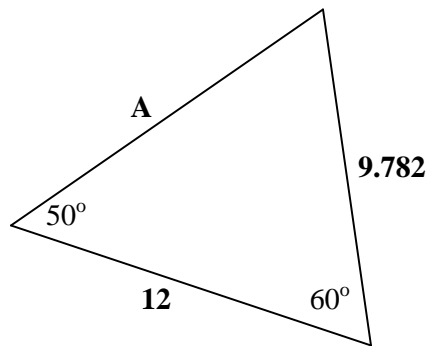

- (A) 11.06
- (B) 12
- (C) 18.67
- (D) 12.77
- (E) 15.48

Question 29 – Trigonometry

Convert an angle of 75 degrees into radians:

- (A) 1.571 radians
- (B) 1.309 radians
- (C) 0.7854 radians
- (D) 1.178 radians
- (E) 3.142 radians

Question 30 – Trigonometry

If the cosine of angle θ is equal to 0.5, and the length of the *opposite* side is 20 meters, calculate the length of the hypotenuse.

- (A) 20.01 meters
- (B) 40 meters
- (C) 17.32 meters
- (D) 44.72 meters
- (E) 23.09 meters

Question 31 – Chemistry and physics

An atom of Lead (Pb) has an atomic number of 82, and an atomic mass of 207. How many neutrons does the nucleus of one Lead atom contain?

- (A) 289
- (B) 82
- (C) 125
- (D) 110
- (E) 207

Question 32 – Chemistry and physics

An *alkaline* solution has a pH value . . .

- (A) at least 11
- (B) greater than 6
- (C) greater than 7
- (D) less than 6
- (E) less than 7

Question 33 – Chemistry and physics

A *catalyst* is a substance that . . .

- (A) moderates the velocities of neutrons in a fission reaction
- (B) buffers an alkaline solution for a more stable pH value
- (C) polarizes light so that the waves are oriented in one plane
- (D) dissolves in water to form an ionic solution
- (E) accelerates a chemical reaction without being consumed

Question 34 – Chemistry and physics

Use the *Ideal Gas Law* to calculate the volume of an ideal gas sample containing 1 mole of gas at 20 degrees C and at a pressure of 2 atmospheres.

- (A) 1.687 liters
- (B) 12.03 liters
- (C) 11.21 liters
- (D) 0.821 liters
- (E) 178.5 liters

Question 35 – Chemistry and physics

A chemical reaction that requires a net input of energy is called:

- (A) Spontaneous
- (B) Catalytic
- (C) Ectomorphic
- (D) Equipotential
- (E) Endothermic

Question 36 – Chemistry and physics

Calculate the kinetic energy of an object moving at a speed of 15 meters per second, having a mass of 40 kilograms.

- (A) 9,000 joules
- (B) 600 joules
- (C) 4,500 joules
- (D) 300 joules
- (E) 12,000 joules

Question 37 – Chemistry and physics

Calculate the gravitational potential energy of a 50 kilogram mass lifted 24 meters vertically above the ground.

- (A) 11,760 joules
- (B) 14,400 joules
- (C) 1,200 joules
- (D) 5,880 joules
- (E) 600 joules

Question 38 – Chemistry and physics

Calculate the angle of the incline necessary so that the cart (on wheels) and the suspended mass precisely balance one another in this cable-and-pulley system. The mass is 450 kg and the cart is 1370 kg:

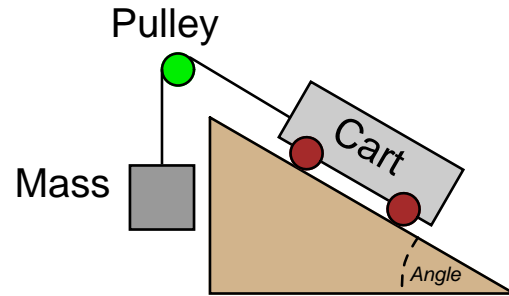

- (A) 23.21°
- (B) 15.08°
- (C) 70.82°
- (D) 18.18°
- (E) 19.18°

Question 39 – Chemistry and physics

The tension in the cable holding up the sign is . . .

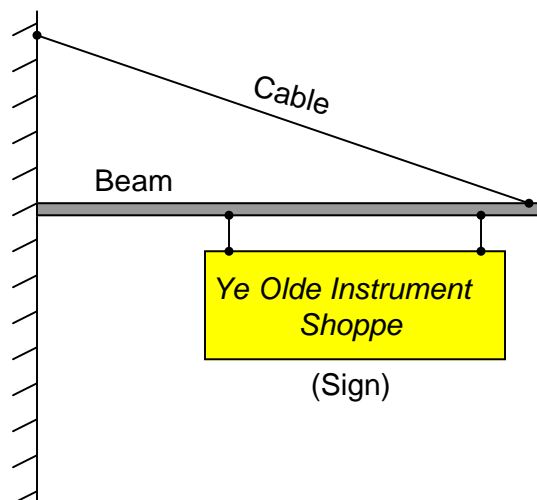

- (A) less than the weight of the sign
- (B) always changing with temperature
- (C) equal to the weight of the sign
- (D) greater than the weight of the sign
- (E) a negative quantity

Question 40 – Chemistry and physics

The *latent heat of vaporization* for water is . . .

- (A) less than the specific heat
- (B) greater than the melting point
- (C) greater than the latent heat of fusion
- (D) less than the latent heat of fusion
- (E) equal to the latent heat of fusion

Question 41 – DC circuit theory

Determine the voltage dropped across resistor R_3 in this circuit:

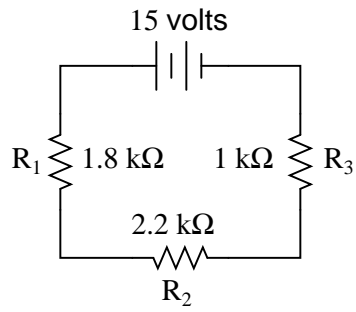

- (A) 7.5 volts
- (B) 3.0 volts
- (C) 6.6 volts
- (D) 15 volts
- (E) 5.4 volts

Question 42 – DC circuit theory

Calculate total current in this circuit:

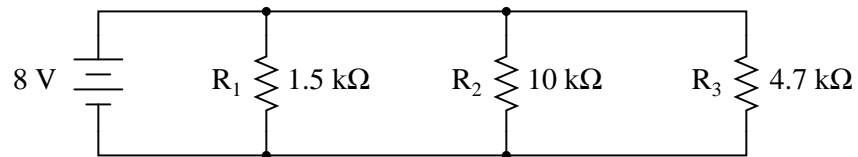

- (A) 493.8 μA
- (B) 5.333 mA
- (C) 8.000 mA
- (D) 7.835 mA
- (E) 8.168 mA

Question 43 – DC circuit theory

Calculate the necessary resistor value (R) to balance this bridge circuit:

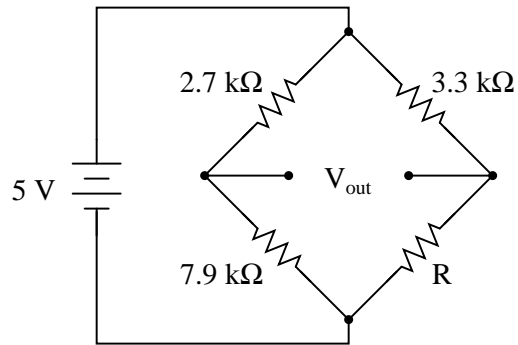

- (A) 9.656 k Ω
- (B) 8.501 k Ω
- (C) 5.830 k Ω
- (D) 7.299 k Ω
- (E) 6.464 k Ω

Question 44 – DC circuit theory

Calculate the necessary resistor size for R_1 to make the total circuit current equal to 30 milliamps:

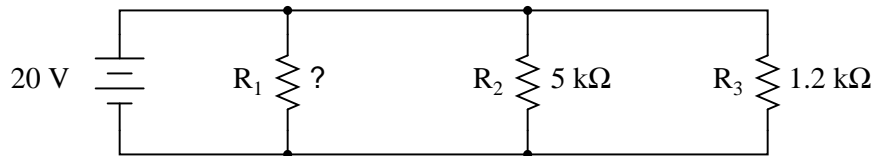

- (A) 2.143 k Ω
- (B) 1.500 k Ω
- (C) 967.7 Ω
- (D) 666.7 Ω
- (E) 310.0 Ω

Question 45 – DC circuit theory

Calculate the current through resistor R_4 in this circuit:

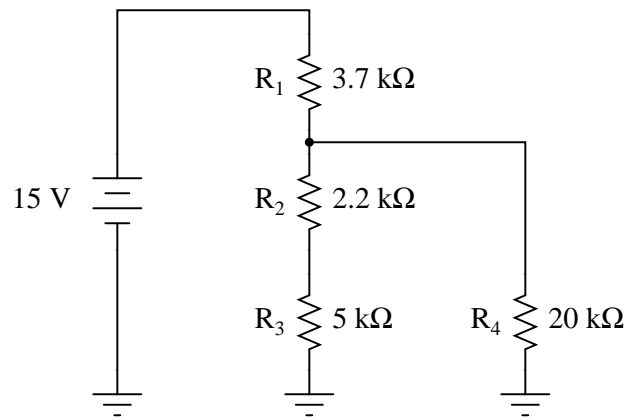

- (A) 4.054 mA
- (B) 8.994 mA
- (C) 1.226 mA
- (D) 441.5 μ A
- (E) 1.668 mA

Question 46 – DC circuit theory

Voltages and currents in an RC or LR time-constant circuit will settle to within 1% of their final value(s) in how many time constants?

- (A) 2
- (B) 4
- (C) 10
- (D) 3
- (E) 5

Question 47 – DC circuit theory

How much voltage will a DMM register if connected with the red test lead on point **B** and the black test lead on point **C**?

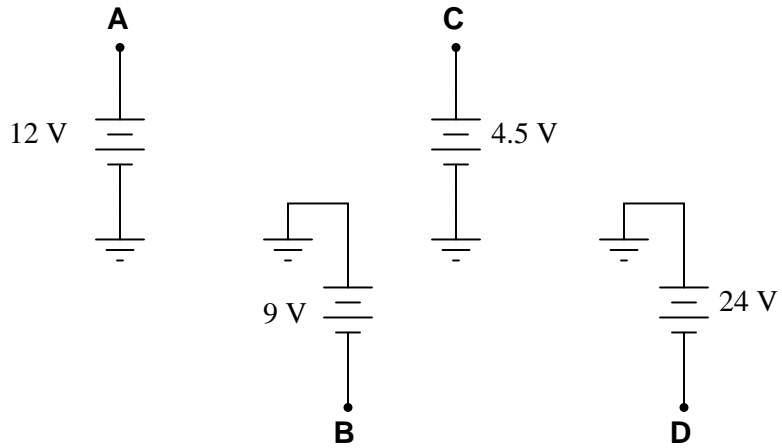

- (A) +4.5 volts
- (B) -4.5 volts
- (C) -13.5 volts
- (D) +13.5 volts
- (E) +2 volts

Question 48 – DC circuit theory

Calculate the voltage between test point **B** and ground in this circuit:

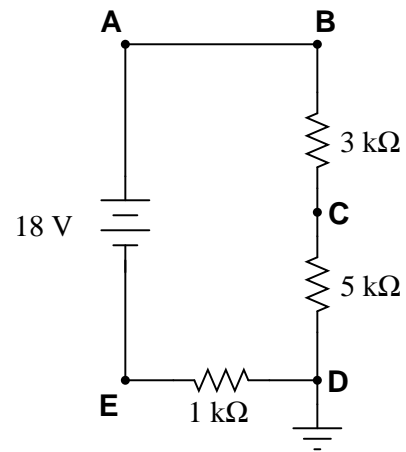

- (A) 20 volts
- (B) 16 volts
- (C) 18 volts
- (D) 2 volts
- (E) 6 volts

Question 49 – DC circuit theory

Determine the magnitude and direction of current through resistor R_4 in this circuit:

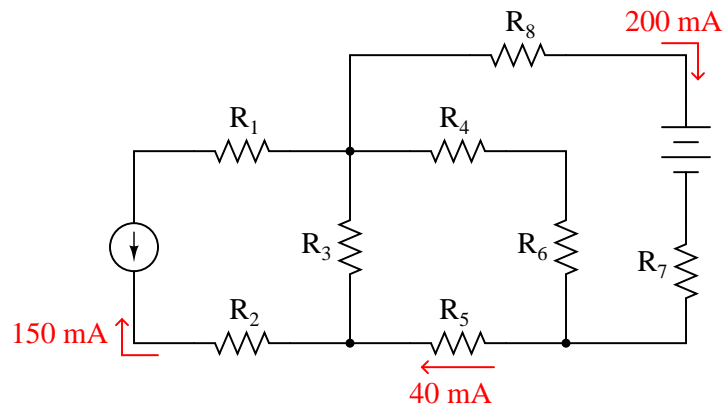

Note: all current arrows point in the direction of electron flow!

- (A) $240\text{ mA} \rightarrow$ (left to right)
- (B) $200\text{ mA} \rightarrow$ (left to right)
- (C) $240\text{ mA} \leftarrow$ (right to left)
- (D) $160\text{ mA} \rightarrow$ (left to right)
- (E) $160\text{ mA} \leftarrow$ (right to left)

Question 50 – DC circuit theory

Determine the magnitude and polarity of the voltage across resistor R_4 in this circuit:

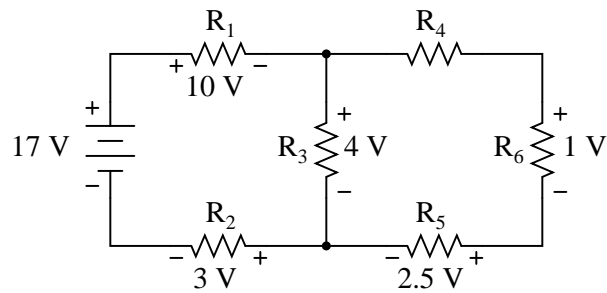

- (A) - 1.0 volt + (negative on left, positive on right)
- (B) + 0.5 volts - (positive on left, negative on right)
- (C) - 7.0 volts + (negative on left, positive on right)
- (D) - 3.5 volts + (negative on left, positive on right)
- (E) + 4.0 volts - (positive on left, negative on right)

Question 51 – AC circuit theory

What will happen to the current in this circuit as frequency *increases*?

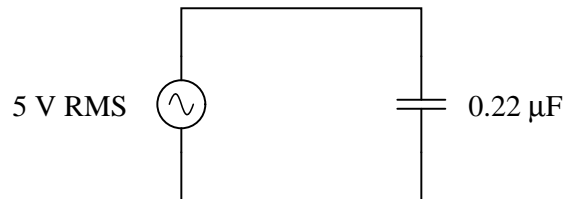

- (A) Current will remain the same
- (B) Cannot tell – not enough information given
- (C) Current will decrease
- (D) Current will decrease to a minimum and then increase
- (E) Current will increase

Question 52 – AC circuit theory

Resonance is defined as a condition in an AC circuit when:

- (A) no more magnetic flux may be forced into an iron core
- (B) opposition to electric current varies with frequency
- (C) complementary reactances are equal and opposite
- (D) voltage and current waveforms are exactly 90° out of phase
- (E) electrons are able to “tunnel” across an energy gap

Question 53 – AC circuit theory

Calculate the source and load currents in this transformer circuit:

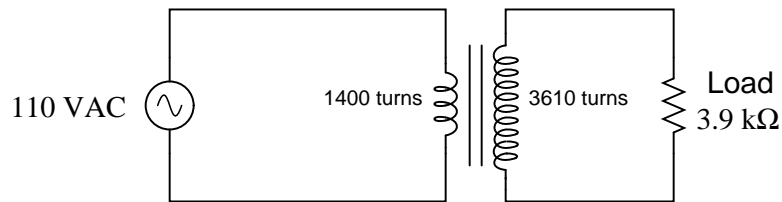

- (A) $I_{source} = 77.22 \text{ mA}$ $I_{load} = 283.6 \text{ mA}$
- (B) $I_{source} = 187.5 \text{ mA}$ $I_{load} = 72.73 \text{ mA}$
- (C) $I_{source} = 186.5 \text{ mA}$ $I_{load} = 72.53 \text{ mA}$
- (D) $I_{source} = 164.2 \text{ mA}$ $I_{load} = 63.66 \text{ mA}$
- (E) $I_{source} = 72.53 \text{ mA}$ $I_{load} = 186.5 \text{ mA}$

Question 54 – AC circuit theory

The function on an oscilloscope that “locks in” waveforms so that they do not scroll horizontally across the screen is called the _____.

- (A) Horizontal sync
- (B) Timebase
- (C) Beam finder
- (D) Trigger
- (E) Cursor

Question 55 – AC circuit theory

A voltage gain of 25 (expressed as a unitless ratio) may also be expressed as _____ decibels (dB).

- (A) 17.78
- (B) 27.96
- (C) 7.959
- (D) 64.38
- (E) 13.98

Question 56 – AC circuit theory

In an AC circuit where current lags voltage by 35° , the power factor is:

- (A) 0.707
- (B) 0.819
- (C) 0.574
- (D) 0.700
- (E) 1.414

Question 57 – AC circuit theory

Determine the frequency of this waveform shown on an oscilloscope screen:

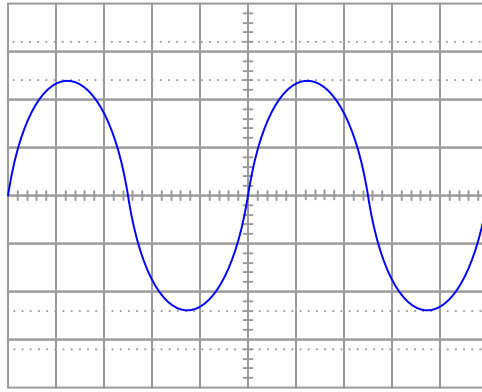

Vertical sensitivity = 2 volts/div
1:1 probe DC coupling
Timebase = 0.5 ms/div

- (A) 400 Hz
- (B) 250 Hz
- (C) 0.4 Hz
- (D) 10 kHz
- (E) 10 Hz

Question 58 – AC circuit theory

Calculate the RMS value of this triangle wave, as shown by the oscilloscope:

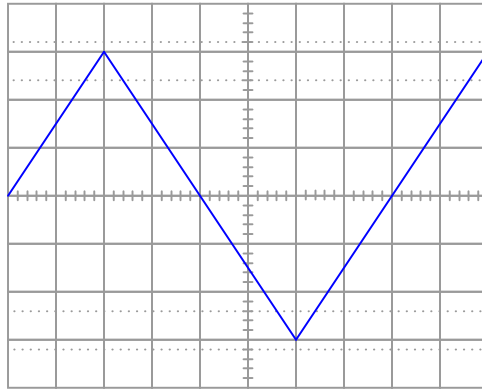

Vertical sensitivity = 10 volts/div
1:1 probe DC coupling
Timebase = 5 μ s/div

- (A) 17.31 volts
- (B) 30 volts
- (C) 3.2 volts
- (D) 21.21 volts
- (E) 32 volts

Question 59 – AC circuit theory

If a communications cable has a *characteristic impedance* of 75 ohms, this means:

- (A) The cable's end-to-end resistance is 75 ohms
- (B) The cable's conductor-to-conductor resistance is 75 ohms
- (C) The cable should be terminated with a resistance equal to 37.5 ohms
- (D) The cable's conductor resistance is 75 ohms per mile of length
- (E) The cable appears to a pulse signal as a 75 ohm load

Question 60 – AC circuit theory

A *low pass filter* is a circuit that performs the following function:

- (A) Modifies the shape of an AC wave
- (B) Blocks low-frequency signals from passing through
- (C) Passes only the negative (low) portions of an AC wave
- (D) Attenuates low-frequency signals
- (E) Blocks high-frequency signals from passing through

Question 61 – Electric power and motor controls

The heating element used in an industrial electric boiler is rated at 15 kW, at 480 volts, 3 phase. Calculate the current drawn by each line of this 3-phase heater.

- (A) 18.48 amps
- (B) 31.25 amps
- (C) 32.00 amps
- (D) 18.04 amps
- (E) 10.42 amps

Question 62 – Electric power and motor controls

3-phase electrical systems are favored over single-phase systems for power distribution because:

- (A) It would be expensive to convert everything to single phase
- (B) 3-phase systems are easier to understand
- (C) Single-phase electric motors are more rugged
- (D) More power may be transmitted using less copper (wire)
- (E) 3-phase power is easier to step voltage up and down

Question 63 – Electric power and motor controls

An AC *induction motor* works on the principle of:

- (A) A rotating magnetic field
- (B) The Lorentz force
- (C) Voltage stepped up through mutual induction
- (D) Magnetic hysteresis
- (E) Magnetostriction converting magnetism to force

Question 64 – Electric power and motor controls

Variable frequency drives, or *VFDs*, are popular in industry for electric motor control because:

- (A) They increase the available horsepower from a motor
- (B) They cost less than an across-the-line starter
- (C) They make the motor run quieter
- (D) They increase the available torque from a motor
- (E) They potentially save energy

Question 65 – Electric power and motor controls

The “M1” contact in the low-voltage control circuit serves the purpose of:

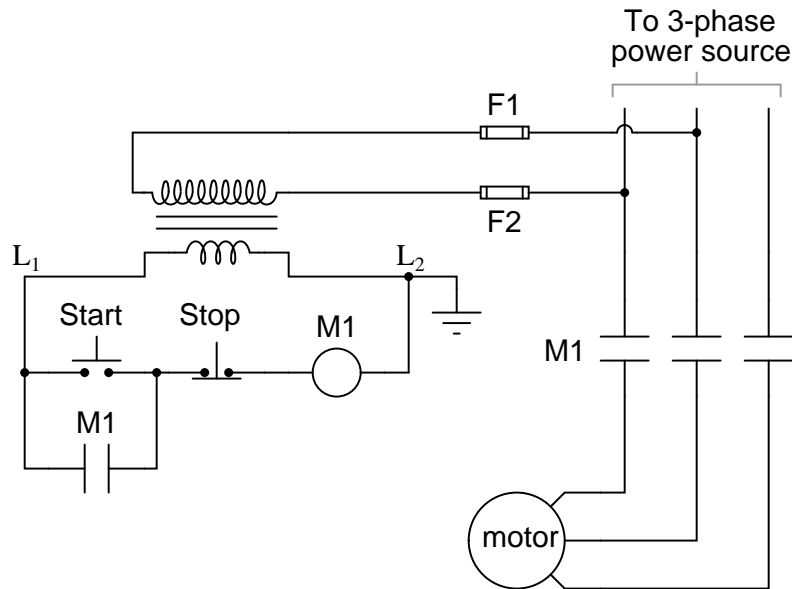

- (A) Latching the motor in the “run” state
- (B) Protecting the motor from overcurrent conditions
- (C) Ensuring the motor will stop even if the “stop” switch fails
- (D) Providing a fail-safe state for the motor
- (E) Indicating when the motor is running

Question 66 – Electric power and motor controls

Overload heaters and overload contacts work together to:

- (A) Protect the motor against mechanical overloading
- (B) Protect the motor against massive overcurrent conditions
- (C) Protect the motor against lubrication failures
- (D) Protect the power lines against overcurrent conditions
- (E) Protect the motor against mild overcurrent conditions

Question 67 – Electric power and motor controls

Calculate the amount of voltage between points **A** and **B** in this balanced three-phase circuit, assuming a generator phase voltage of 4160 volts:

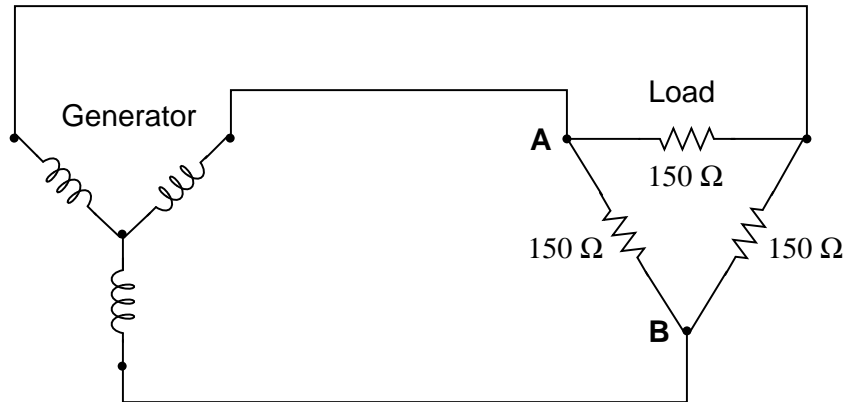

- (A) 27.73 V
- (B) 2.080 kV
- (C) 4.160 kV
- (D) 7.205 kV
- (E) 48.04 V

Question 68 – Electric power and motor controls

A single-phase AC electric motor draws 54.7 amps while being powered by a 240 volt source. Assuming perfect power factor (1.0) and an efficiency of 87%, calculate the mechanical horsepower output by this motor.

- (A) 20.24 hp
- (B) 17.18 hp
- (C) 14.95 hp
- (D) 15.32 hp
- (E) 17.60 hp

Question 69 – Electric power and motor controls

A *synchronous* motor differs from an *induction* motor by the fact that . . .

- (A) its speed is constant
- (B) it operates on DC instead of AC
- (C) it uses fewer poles
- (D) it must be properly “timed”
- (E) it uses brushes

Question 70 – Electric power and motor controls

DC motors are used in industry where . . .

- (A) the motor must tolerate constant vibration
- (B) low maintenance is necessary
- (C) the motor’s speed must remain constant
- (D) explosive gases may be present
- (E) superior low-speed torque is needed

Question 71 – Semiconductor circuit theory

P-type semiconductor materials are made to be that way due to _____ doping.

- (A) trivalent
- (B) intrinsic
- (C) nonvalent
- (D) pentavalent
- (E) extrinsic

Question 72 – Semiconductor circuit theory

Identify the labels used to describe the left- and right-hand leads on this diode (respectively):



- (A) Anion and cation
- (B) Cation and anion
- (C) Cathode and anode
- (D) Anode and cathode
- (E) Pentode and tetrode

Question 73 – Semiconductor circuit theory

Identify the terminals of this transistor:

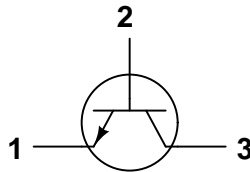

- (A) 1 = Drain ; 2 = Gate ; 3 = Source
- (B) 1 = Emitter ; 2 = Base ; 3 = Collector
- (C) 1 = Source ; 2 = Gate ; 3 = Drain
- (D) 1 = Gate ; 2 = Emitter ; 3 = Drain
- (E) 1 = Collector ; 2 = Base ; 3 = Emitter

Question 74 – Semiconductor circuit theory

A *Hall Effect* device is a component typically used to . . .

- (A) measure magnetic field strength
- (B) measure an electrical resistance
- (C) detect vibration in machinery
- (D) suppress transient voltages
- (E) switch current on and off

Question 75 – Semiconductor circuit theory

Estimate the amount of voltage between point **A** and ground in this transistor amplifier circuit under quiescent conditions. Assume an ideal silicon transistor:

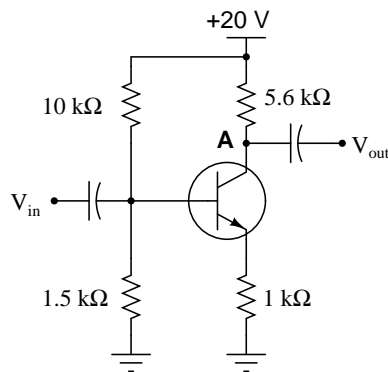

- (A) 9.31 volts
- (B) 14.4 volts
- (C) 2.61 volts
- (D) 1.91 volts
- (E) 19.3 volts

Question 76 – Semiconductor circuit theory

Calculate the voltage between point **A** and ground in this operational amplifier circuit:

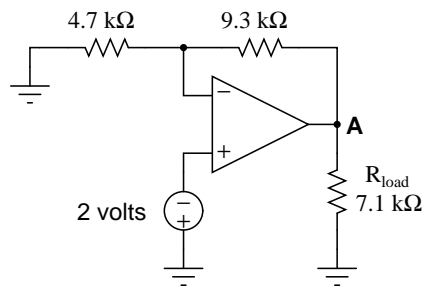

- (A) -2.00 volts
- (B) -2.58 volts
- (C) +2.58 volts
- (D) -5.96 volts
- (E) +3.96 volts

Question 77 – Semiconductor circuit theory

Estimate the DC output voltage of this power supply circuit, when unloaded. Assume the use of silicon rectifying diodes:

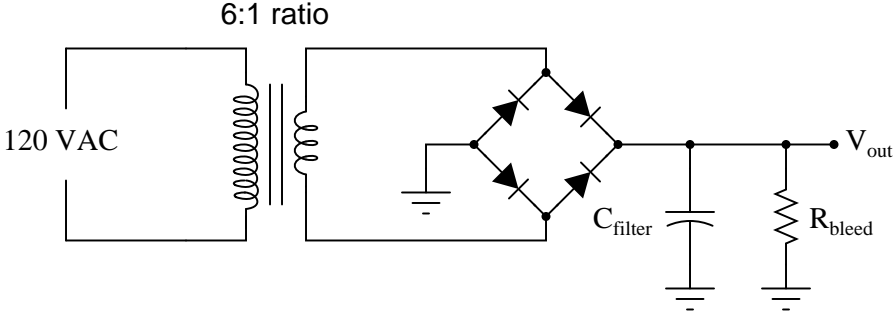

- (A) 26.9 volts
- (B) 42.4 volts
- (C) 18.6 volts
- (D) 19.3 volts
- (E) 20.0 volts

Question 78 – Semiconductor circuit theory

When the pushbutton switch is actuated, the LED will:

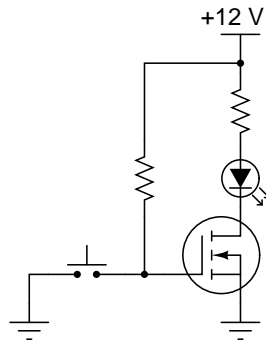

- (A) turn on
- (B) burn up
- (C) blink on and off
- (D) become dim
- (E) turn off

Question 79 – Semiconductor circuit theory

The following circuit is typically used to:

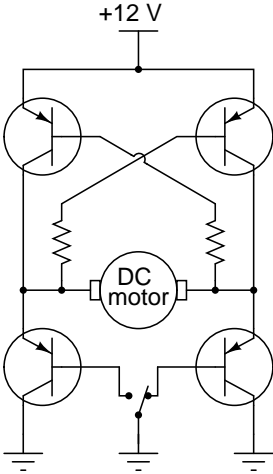

- (A) change motor direction
- (B) control motor speed
- (C) control motor torque
- (D) limit motor current
- (E) control motor frequency

Question 80 – Semiconductor circuit theory

Identify the function of this DC-DC converter circuit:

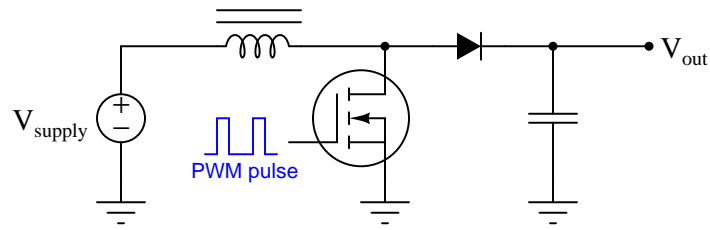

- (A) Boost or Buck voltage ; same output polarity as input
- (B) Buck voltage ; same output polarity as input
- (C) Boost voltage ; inverted output polarity
- (D) Buck voltage ; inverted output polarity
- (E) Boost voltage ; same output polarity as input

Question 81 – Digital circuit theory

Convert the decimal number 45,688 into binary.

- (A) 1000011100101011
- (B) 1011001001111000
- (C) 1010110011000010
- (D) 1110111000011011
- (E) 1001101011001110

Question 82 – Digital circuit theory

The two's complement of the binary number 11001111 is:

- (A) 11010000
- (B) 11110011
- (C) 00110000
- (D) 11110100
- (E) 00110001

Question 83 – Digital circuit theory

The Boolean representation of this digital logic gate circuit is:

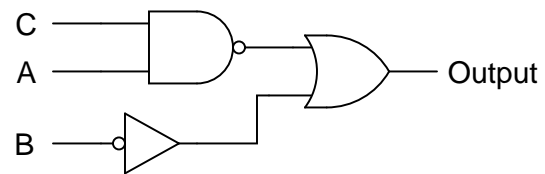

- (A) $\overline{B} \overline{A} + C$
- (B) $\overline{B} + \overline{A} \overline{C}$
- (C) $\overline{B} + \overline{AC}$
- (D) $\overline{B} + \overline{A} \overline{C}$
- (E) $\overline{B} + \overline{AC}$

Question 84 – Digital circuit theory

The Boolean representation of this truth table is:

A	B	C	Output
0	0	0	0
0	0	1	0
0	1	0	1
0	1	1	0
1	0	0	0
1	0	1	0
1	1	0	1
1	1	1	0

- (A) $A\bar{C}$
- (B) B
- (C) $B\bar{C}$
- (D) $\bar{A}\bar{B}C$
- (E) $AB + \bar{C}$

Question 85 – Digital circuit theory

The *reset* state of a flip-flop circuit is defined as:

- (A) $Q = 1$ and $\bar{Q} = 0$
- (B) $Q = 1$ and $\bar{Q} = 1$
- (C) $Q = 0$ and $\bar{Q} = 1$
- (D) Clock = falling edge
- (E) $Q = 0$ and $\bar{Q} = 0$

Question 86 – Digital circuit theory

Switch *debouncing* is a technique used for the purpose of:

- (A) Filtering noise
- (B) Extending the operating life of a switch
- (C) Canceling the effects of vibration
- (D) Eliminating false switching events
- (E) Reducing switch contact arcing

Question 87 – Digital circuit theory

In an electronic circuit schematic, V_{EE} represents:

- (A) The negative power supply rail of a bipolar transistor circuit
- (B) The negative power supply rail of a field-effect transistor circuit
- (C) The positive power supply rail of a field-effect transistor circuit
- (D) The positive power supply rail of a bipolar transistor circuit
- (E) The positive power supply rail of an ECL transistor circuit

Question 88 – Digital circuit theory

ASCII is a digital code used for:

- (A) Representing alphanumeric characters
- (B) Code breaking
- (C) Detecting and correcting data errors
- (D) Organizing data stored on a hard disk
- (E) Describing angular position on a rotary encoder

Question 89 – Digital circuit theory

The following digital circuit is commonly known as a _____

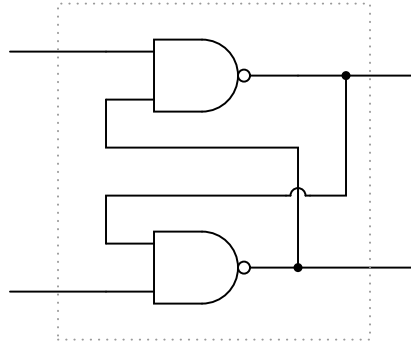

- (A) gate
- (B) latch
- (C) counter
- (D) register
- (E) one-shot

Question 90 – Digital circuit theory

A digital logic gate equipped with a *tri-state* output is able to:

- (A) Share an output line with another gate
- (B) Latch an input state for later use
- (C) Produce an intermediate voltage state
- (D) Switch faster than a regular gate
- (E) Operate with three times less power

Question 91 – Basic control theory

A basic control loop will consist of:

- (A) signal converter, resistor, knob, and control valve
- (B) transmitter, controller, I/P transducer, and control valve
- (C) transducer, valve packing, hex-head wrench, and tubing
- (D) resistor, capacitor, terminal block, and battery
- (E) control valve, microprocessor, terminal block, and cables

Question 92 – Basic control theory

In order for a control loop to work well under a wide range of conditions, it must possess:

- (A) A very expensive transmitter
- (B) Calibration drift
- (C) Negative feedback
- (D) Hysteresis
- (E) Proper documentation

Question 93 – Basic control theory

A “final control element” is typically:

- (A) An indicator
- (B) A pipe or vessel
- (C) A pneumatic instrument
- (D) A sensor
- (E) A valve

Question 94 – Basic control theory

When connecting shield wires on an instrument signal cable, it is best to:

- (A) Ground the shield conductor only at one end of the cable
- (B) Ground the shield conductor at both ends of the cable
- (C) Connect the shield conductor to the “hot” AC power wire
- (D) Connect the shield conductor to the “neutral” AC power wire
- (E) Leave both shield conductors floating (unconnected)

Question 95 – Basic control theory

The most common analog signal standard for industrial process instruments is:

- (A) 10 to 50 milliamps DC
- (B) 0 to 5 amps AC
- (C) 0 to 10 volts
- (D) 0 to 20 milliamps
- (E) 4 to 20 milliamps DC

Question 96 – Basic control theory

In a process controller, “setpoint” refers to:

- (A) The minimum value for the high-alarm point
- (B) The maximum value for the low-alarm point
- (C) The production quota for each work day
- (D) The target value for the measured variable
- (E) The optimum position of the control valve

Question 97 – Basic control theory

Identify which of the following is not an example of a “primary sensing element”:

- (A) Bourdon tube
- (B) Torque tube
- (C) Pitot tube
- (D) pH electrode
- (E) Thermocouple

Question 98 – Basic control theory

Identify the controller's proper action in the event that the thermocouple suddenly detects a *drop* in process temperature:

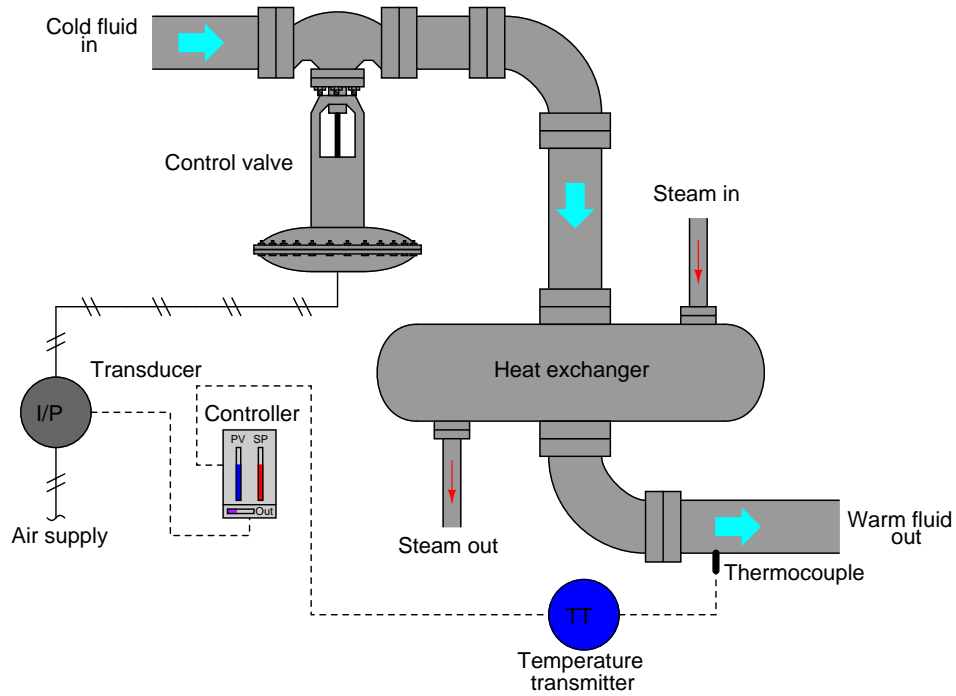

- (A) Move the control valve further closed
- (B) Re-calibrate the temperature transmitter
- (C) Move the control valve further open
- (D) Completely open the control valve
- (E) Hold the control valve's position steady

Question 99 – Basic control theory

In an automobile “cruise control” system, the vehicle’s speed is the:

- (A) Process variable
- (B) Setpoint
- (C) Manipulated variable
- (D) Inferred variable
- (E) Error variable

Question 100 – Basic control theory

The main purpose of having a “manual” mode on a process controller is to:

- (A) Document maintenance work done on the loop
- (B) Allow a human operator to take control of the process
- (C) Provide a way to adjust the alarm points
- (D) Facilitate calibration of the loop instruments
- (E) Limit the maximum travel of the control valve

Question 101 – Calibration principles

Identify the type of instrument calibration error(s) shown in this graph:

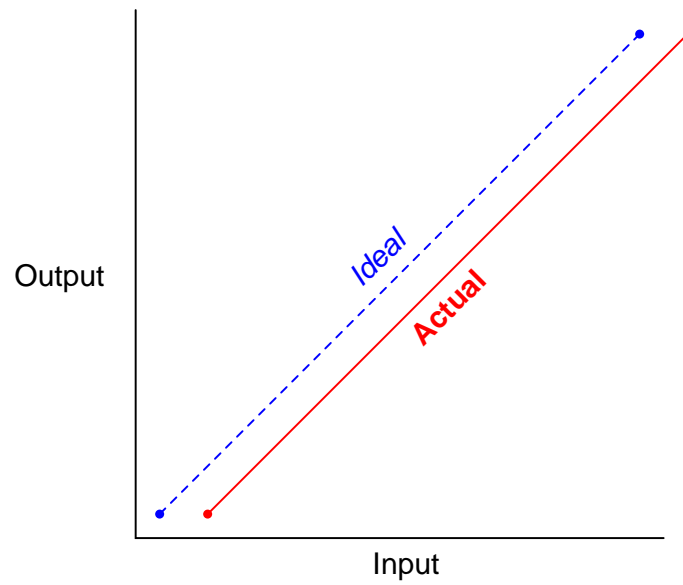

- (A) Linearity error
- (B) Zero error
- (C) Span error
- (D) Hysteresis error
- (E) Both zero and span errors

Question 102 – Calibration principles

Identify the type of instrument calibration error(s) shown in this graph:

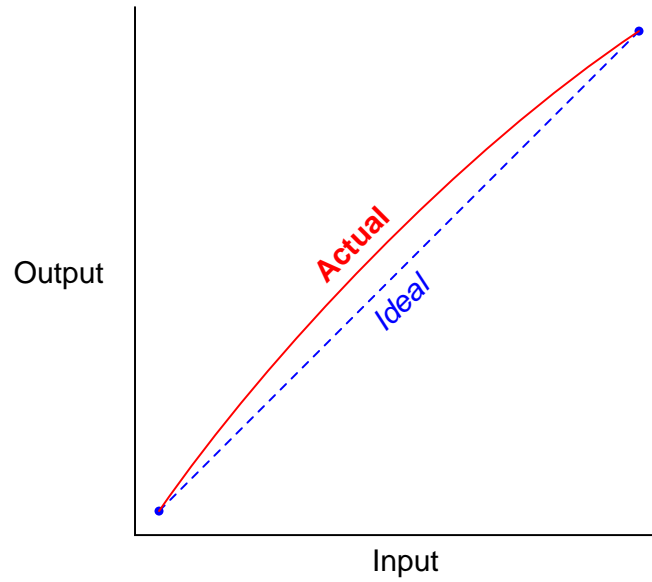

- (A) Span error
- (B) Hysteresis error
- (C) Linearity error
- (D) Zero error
- (E) Both zero and span errors

Question 103 – Calibration principles

The purpose of performing an “As Found” calibration on an instrument is to:

- (A) Eliminate hysteresis and deadband from the instrument
- (B) Spend more time calibrating the instrument
- (C) Establish a baseline for comparison, to detect calibration drift
- (D) “Exercise” the instrument to keep it in better condition over time
- (E) Diagnose control problems in the loop

Question 104 – Calibration principles

A technician is calibrating an adjustable, mechanical pressure switch using an air pressure regulator and a precision pressure gauge. Assuming this pressure switch will be used as a high pressure alarm (tripping when the pressure exceeds 50 PSI), the technician should do the following:

- (A) Set the pressure at 50 PSI and move the switch adjustment up until it actuates
- (B) Set the pressure at 50 PSI and move the switch adjustment down until it actuates
- (C) Adjust the switch so it actuates when the pressure decreases to 51 PSI
- (D) Adjust the switch so it actuates when the pressure increases to 49 PSI
- (E) Purchase a pressure switch factory-set at 50 PSI

Question 105 – Calibration principles

Which of the following adjustments is usually adjusted *first* in an instrument requiring calibration?

- (A) Deadband
- (B) Span
- (C) Hysteresis
- (D) Zero
- (E) Linearity

Question 106 – Calibration principles

An error tolerance of +/- 0.5% is _____ for a 4-20 mA instrument signal.

- (A) +/- 0.04 mA
- (B) +/- 0.5 mA
- (C) +/- 0.1 mA
- (D) +/- 0.08 mA
- (E) +/- 0.02 mA

Question 107 – Calibration principles

A pressure transmitter has a calibrated measurement range of 200 to 300 PSIG, and an output range of 4-20 mA. What is the expected output if the input pressure is 235 PSIG?

- (A) 9.6 mA
- (B) 1.6 mA
- (C) 16.5 mA
- (D) 5.6 mA
- (E) 12.5 mA

Question 108 – Calibration principles

A pH transmitter has a calibrated range of 5 to 9 pH, with a 4-20 mA output. What is the pH measurement if the transmitter's output is equal to 17.3 mA?

- (A) 4.156 pH
- (B) 6.599 pH
- (C) 8.325 pH
- (D) 8.460 pH
- (E) 7.481 pH

Question 109 – Calibration principles

A proper place to record the calibrated range of an instrument is:

- (A) On the packing slip that came with the instrument
- (B) In the text section of a loop diagram sheet
- (C) Next to the cable symbols for that instrument on a wiring diagram
- (D) On a safety lock-out tag
- (E) Inside the nearest electrical junction box

Question 110 – Calibration principles

A “smart” transmitter is one that:

- (A) Communicates using Foundation Fieldbus
- (B) Calibrates itself
- (C) Also plays MP3 music files
- (D) Has multiple process sensors
- (E) Has a microprocessor built inside

Question 111 – Pressure measurement

Convert a pressure measurement of 800 torr into units of PSI (gauge)

- (A) 1.053 PSIG
- (B) 21.42 PSIG
- (C) 0.7737 PSIG
- (D) 54.42 PSIG
- (E) 15.47 PSIG

Question 112 – Pressure measurement

Which of the following is *not* a type of pressure sensing element?

- (A) Orifice plate
- (B) Bourdon tube
- (C) Manometer
- (D) Diaphragm
- (E) Bellows

Question 113 – Pressure measurement

If a force of 3400 pounds is applied to a circular piston 2 inches in diameter, calculate the fluid pressure working against the piston.

- (A) 344.5 PSI
- (B) 1082.3 PSI
- (C) 850 PSI
- (D) 1700 PSI
- (E) 270.6 PSI

Question 114 – Pressure measurement

Another word for “pressure” is:

- (A) Force
- (B) Density
- (C) Head
- (D) pH
- (E) Flow

Question 115 – Pressure measurement

If the pressure applied to the “high” side of a ΔP transmitter decreases while the pressure applied to the “low” side remains steady, the transmitter output should:

- (A) Remain unchanged
- (B) Decrease
- (C) Increase
- (D) Fluctuate back and forth
- (E) Saturate

Question 116 – Pressure measurement

Identify the proper sequence of valve actions for a three-valve manifold and bleed when taking a differential pressure transmitter out of service:

- (A) Open bleed, close one block valve, open equalizing valve, close other block valve
- (B) Open equalizing valve, close both block valves (simultaneously), open bleed
- (C) Open equalizing valve, open bleed, close both block valves (simultaneously)
- (D) Close one block valve, open bleed, close other block valve, open equalizing valve
- (E) Close one block valve, open equalizing valve, close other block valve, open bleed

Question 117 – Pressure measurement

Identify the condition that could cause pressure gauge **A** to register a greater pressure than pressure gauge **B** in this liquid process:

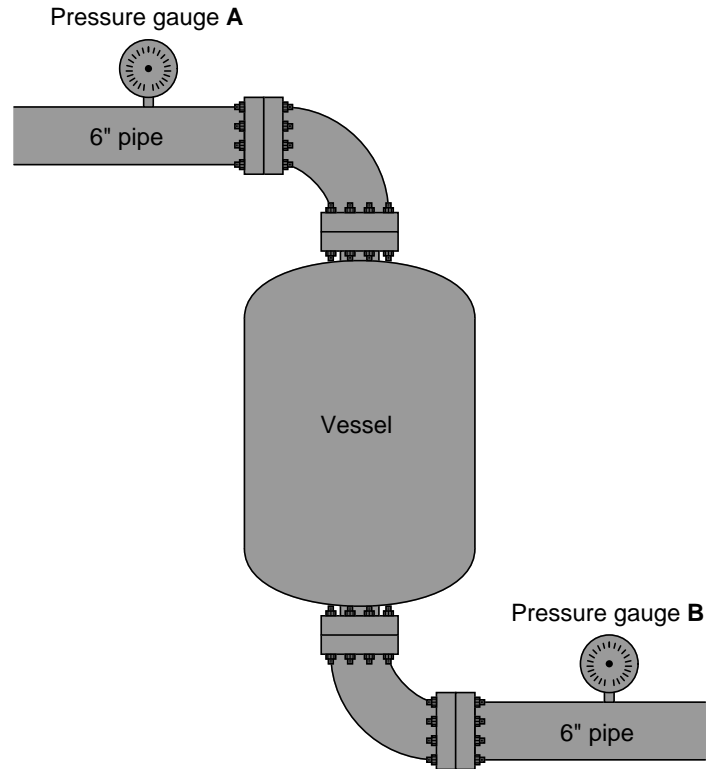

- (A) A high rate of flow from left to right (top to bottom through the vessel)
- (B) An extremely dense liquid
- (C) Liquid boiling inside the vessel
- (D) A high rate of flow from right to left (bottom to top through the vessel)
- (E) Pressure gauge **B** calibrated for absolute pressure units instead of gauge units

Question 118 – Pressure measurement

How much differential pressure does this manometer indicate?

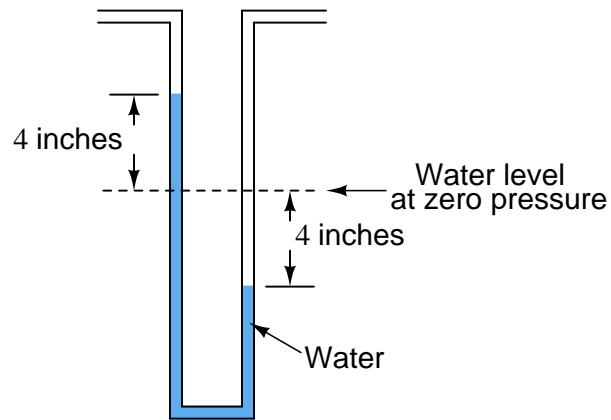

- (A) 0.272 "W.C.
- (B) 745 torr
- (C) 3.929 "W.C.
- (D) 4.00 "W.C.
- (E) 8.00 "W.C.

Question 119 – Pressure measurement

Suppose the following pneumatic ΔP transmitter (same working principle as the Foxboro models 13 and 15) was calibrated to a range of 0 to 250 inches water column:

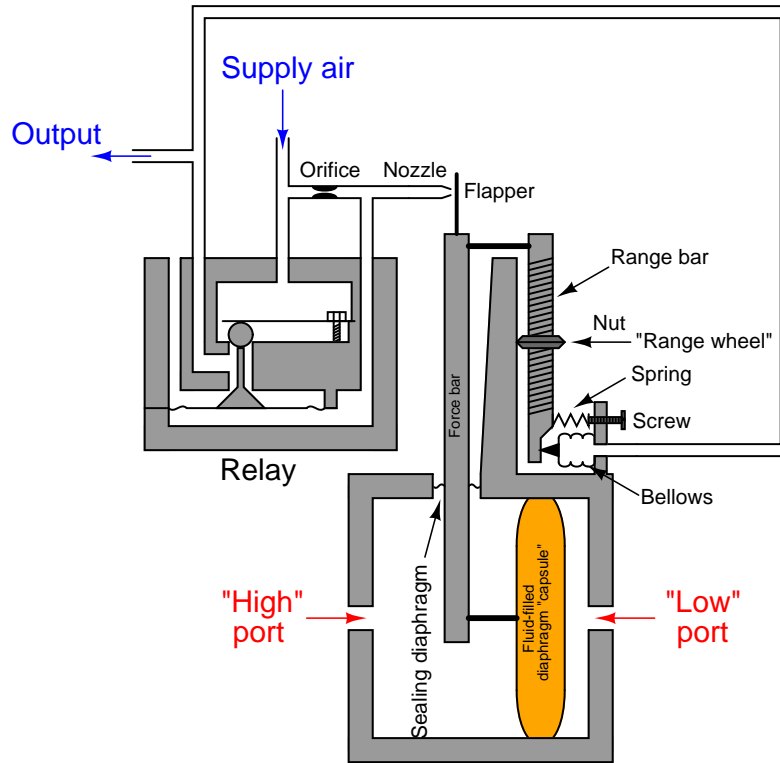

What would have to be done to it to re-calibrate it for a new range of 100 to 350 inches water column?

- (A) Turn the screw (located near the bellows)
- (B) Bend the flapper (next to the nozzle)
- (C) Turn the range wheel nut (located in the middle of the range bar)
- (D) Re-size the orifice (located between air supply and nozzle)
- (E) Replace the diaphragm capsule with one of a different size

Question 120 – Pressure measurement

The following circuit shows three pressure switches that all measure the same process pressure, but activate different electrical loads:

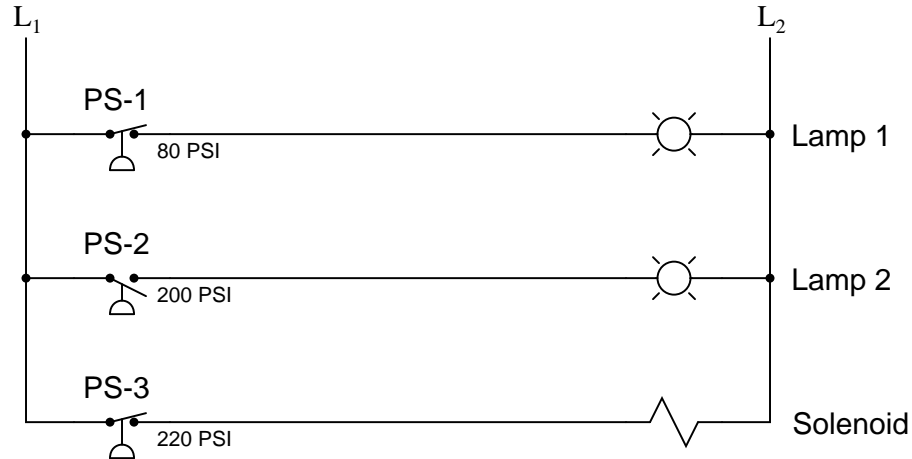

Determine the statuses of these loads at a pressure pressure of 210 PSI.

- (A) Lamp 1 off, Lamp 2 on, Solenoid on
- (B) Lamp 1 on, Lamp 2 on, Solenoid on
- (C) Lamp 1 on, Lamp 2 off, Solenoid on
- (D) Lamp 1 off, Lamp 2 on, Solenoid off
- (E) Lamp 1 on, Lamp 2 off, Solenoid off

Question 121 – Level measurement

Suppose a storage vessel holds a liquid of unpredictable density. Identify which level measurement technology will *not* maintain accurate measurement of liquid height in the vessel as the liquid density changes:

- (A) Sightglass
- (B) Guided-wave radar
- (C) Float and tape
- (D) Differential pressure transmitter
- (E) Ultrasonic

Question 122 – Level measurement

The main advantage of a “dip tube” or “bubbler” system for level measurement is that:

- (A) It can measure both solid and liquid levels
- (B) It compensates for changes in liquid density
- (C) It isolates the pressure transmitter from the process fluid
- (D) It always elevates and never suppresses the calibration range
- (E) It is less expensive to operate than a direct-connected transmitter

Question 123 – Level measurement

If we alter this level measurement system to have a *wet leg* instead of a *dry leg*, what single aspect of the transmitter’s calibration will we need to change?

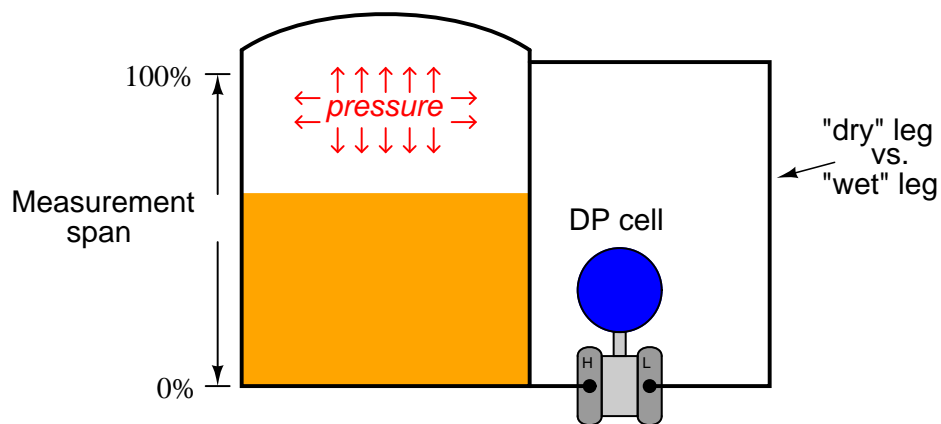

- (A) We will need to change the transmitter’s *URV*
- (B) We will need to change the transmitter’s *span*
- (C) We will need to change the transmitter’s *zero*
- (D) We will need to change the transmitter’s *LRV*
- (E) We will need to change the transmitter’s *linearity*

Question 124 – Level measurement

A displacer-type level transmitter has a cylindrical displacer 30 inches long and 2.5 inches in diameter. When fully submerged in a petroleum fuel ($G_f = 0.82$), how much buoyant force will the displacer generate?

- (A) 5.320 pounds
- (B) 6.488 pounds
- (C) 2.792 pounds
- (D) 17.45 pounds
- (E) 4.363 pounds

Question 125 – Level measurement

Calculate the LRV and URV for this ΔP -based liquid level measurement system:

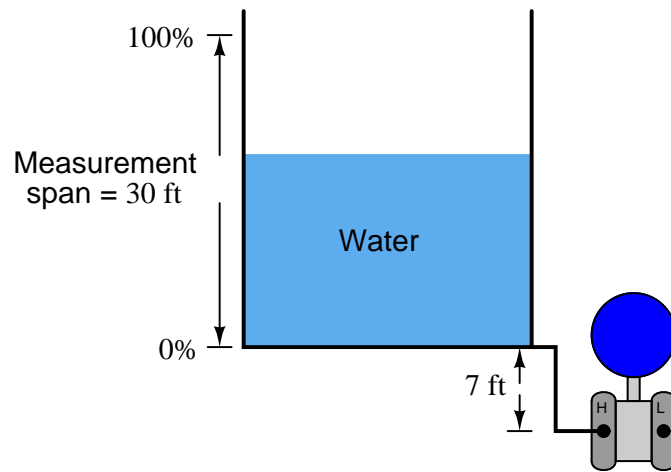

- (A) LRV = 444 "H₂O ; URV = 0 "H₂O
- (B) LRV = 0 "H₂O ; URV = 360 "H₂O
- (C) LRV = 0 "H₂O ; URV = 444 "H₂O
- (D) LRV = 84 "H₂O ; URV = 444 "H₂O
- (E) LRV = 7 "H₂O ; URV = 37 "H₂O

Question 126 – Level measurement

A d/p cell used to measure liquid level has a “suppressed zero.” This means:

- (A) The transmitter is located above the 0% liquid level mark
- (B) The transmitter uses filter circuits to suppress noise to a zero level
- (C) The liquid is less dense than water
- (D) The transmitter is located below the 0% liquid level mark
- (E) The elevation of the vessel is below sea level

Question 127 – Level measurement

Which of the following level-measurement technologies *cannot* be adapted to measure solid (powder) level in a vessel?

- (A) Float and tape
- (B) Ultrasonic
- (C) Load cell
- (D) Displacer
- (E) Radar

Question 128 – Level measurement

A guided-wave radar transmitter is able to measure liquid interface levels based on differences of _____ between the two liquids.

- (A) Ionization potential
- (B) Density
- (C) Speed of light
- (D) Temperature
- (E) Dielectric constant

Question 129 – Level measurement

The following liquid level switch will only function with liquids that are _____.

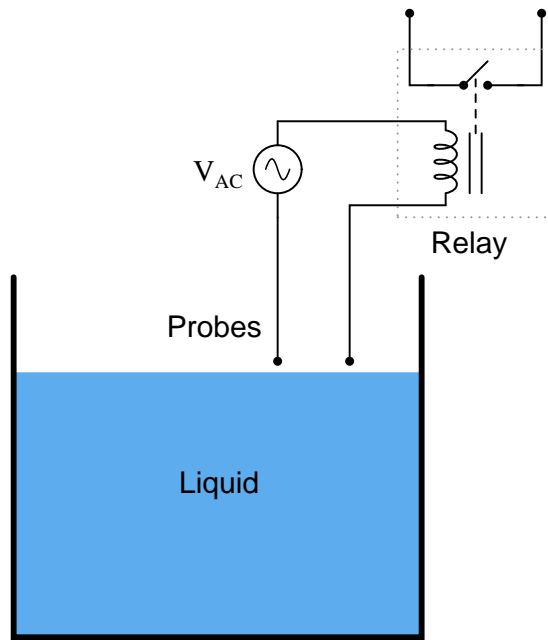

- (A) Absolutely pure (i.e. not a solution)
- (B) In a state of laminar flow
- (C) Optically transparent
- (D) Electrically conductive
- (E) Denser than water

Question 130 – Level measurement

Calculate the hydrostatic pressure at the bottom of a vessel holding 12 vertical feet of liquid with a density of 50 lb/ft³.

- (A) 18.867 PSI
- (B) 14.98 PSI
- (C) 5.202 PSI
- (D) 4.167 PSI
- (E) 6.495 PSI

Question 131 – Temperature measurement

Identify the thermocouple type with the highest temperature limit from those listed here:

- (A) Type S
- (B) Type T
- (C) Type E
- (D) Type J
- (E) Type K

Question 132 – Temperature measurement

The negative lead of a thermocouple is always colored:

- (A) Yellow
- (B) Red
- (C) White
- (D) Black
- (E) Blue

Question 133 – Temperature measurement

The most linear temperature sensing element listed here is a/an:

- (A) RTD
- (B) Thermistor
- (C) Bellows
- (D) Diode
- (E) Thermocouple

Question 134 – Temperature measurement

Convert a temperature measurement of 520° F into Kelvin.

- (A) 793.2 K
- (B) 979.7 K
- (C) 544.3 K
- (D) 530.0 K
- (E) 246.9 K

Question 135 – Temperature measurement

When the reference junction is the same temperature as the measurement junction in a thermocouple circuit, the output voltage (measured by the sensing instrument) is:

- (A) Noisy
- (B) Unreliable
- (C) Reverse polarity
- (D) AC instead of DC
- (E) Zero

Question 136 – Temperature measurement

A “thermowell” is a:

- (A) Protective tube for a temperature sensing element
- (B) Temperature sensing device
- (C) Safety relief device for high pressure
- (D) Heat sink
- (E) Small vessel for holding liquids at high temperature

Question 137 – Temperature measurement

Reference junction compensation is necessary in thermocouple-based temperature instruments because:

- (A) Thermocouples are inherently nonlinear
- (B) The reference junction generates a temperature-dependent voltage
- (C) The junction's electrical resistance varies with temperature
- (D) Electrical noise may interfere with the measurement otherwise
- (E) Copper extension wire has a tendency to corrode

Question 138 – Temperature measurement

Latent heat is:

- (A) The amount of heat energy present in ambient conditions
- (B) The heat required to make a substance change phase
- (C) The potential energy residing in a sample of unburnt fuel
- (D) The heat released when a gas suddenly decreases pressure
- (E) The heat required to raise the temperature of a substance

Question 139 – Temperature measurement

Thermocouple *extension wire* may be readily distinguished from regular thermocouple-grade wire by:

- (A) Different metal types
- (B) Special markings on the wire's insulation
- (C) Thickness
- (D) Flexibility (stranded instead of solid)
- (E) Outer sheath color

Question 140 – Temperature measurement

A *type K* thermocouple is made of the following metals:

- (A) Chromel and Alumel
- (B) Copper and Constantan
- (C) Aluminum and Tungsten
- (D) Platinum and Platinum/Rhodium alloy
- (E) Iron and Constantan

Question 141 – Flow measurement

Which of the following flow-measuring elements is inherently linear and requires no signal characterization (e.g. square-root extraction) anywhere in the loop?

- (A) Target
- (B) Venturi
- (C) Turbine
- (D) Orifice plate
- (E) Pitot tube

Question 142 – Flow measurement

Bernoulli's Equation is a mathematical expression of:

- (A) Fluid density and compressibility in a restriction
- (B) Vertical height and pressure for a static fluid
- (C) The ratio of kinetic to viscous forces in a flow stream
- (D) Friction loss as fluid moves through a rough pipe
- (E) Potential and kinetic energies in a flow stream

Question 143 – Flow measurement

As an incompressible fluid moves through a restriction,

- (A) Velocity decreases and pressure remains the same
- (B) Velocity decreases and pressure increases
- (C) Velocity increases and pressure increases
- (D) Velocity increases and pressure remains the same
- (E) Velocity increases and pressure decreases

Question 144 – Flow measurement

A flag flapping in the breeze illustrates what type of dynamic fluid effect?

- (A) Vortex shedding
- (B) Transitional flow
- (C) Coriolis effect
- (D) Laminar flow
- (E) Cavitation

Question 145 – Flow measurement

For accurate operation, orifice plate flowmeters require:

- (A) Swirls and eddies in the flow stream
- (B) Transitional flow
- (C) Plug flow
- (D) Laminar flow
- (E) Fully-developed turbulent flow

Question 146 – Flow measurement

A magnetic flowmeter will not properly measure the flow rate of:

- (A) Dirty water
- (B) Milk
- (C) Caustic
- (D) Oil
- (E) Acid

Question 147 – Flow measurement

Based on the relative positions of transmitter and orifice plate, this flow-measuring installation is suitable for:

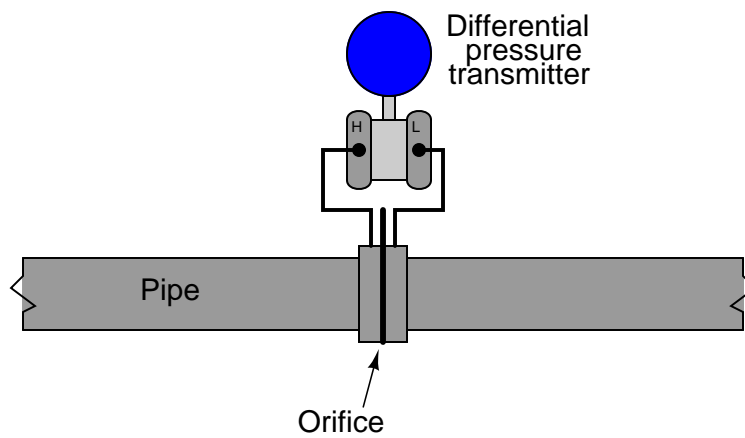

- (A) Water or oil flow
- (B) Gas flow
- (C) Steam flow
- (D) Laminar flow
- (E) Slurry flow

Question 148 – Flow measurement

Flow-straightening vanes are used upstream of orifice plate flow elements when:

- (A) Accuracy is not a concern
- (B) The process fluid is a gas
- (C) The flow profile is laminar
- (D) Insufficient straight-pipe length exists
- (E) The process fluid is a liquid

Question 149 – Flow measurement

A ΔP transmitter calibrated for a range of 0 to 100 "H₂O measures liquid flow through an orifice plate from 0 to 1200 GPH. Calculate the new calibration range for the transmitter if we desire to decrease the flow measurement range to 0 to 700 GPH, using the same orifice plate.

- (A) 0 to 34.03 "H₂O
- (B) 0 to 76.38 "H₂O
- (C) 0 to 171.4 "H₂O
- (D) 0 to 293.9 "H₂O
- (E) 0 to 58.33 "H₂O

Question 150 – Flow measurement

Identify which of the following flowmeters inherently measures *mass* flow rate:

- (A) Magnetic
- (B) Flow nozzle
- (C) Thermal
- (D) Vortex
- (E) Venturi tube

Question 151 – Analytical measurement

The pH of a liquid solution is a measure of:

- (A) Dissolved salt content
- (B) Hydroxyl ion molarity
- (C) Hydrogen ion activity
- (D) Electrical conductivity
- (E) Sodium ion molarity

Question 152 – Analytical measurement

A pH value less than 7.0 means that the solution is:

- (A) Acidic
- (B) Alkaline
- (C) Conductive
- (D) Caustic
- (E) Hot

Question 153 – Analytical measurement

The *Nernst equation* relates:

- (A) O₂ concentration to latent heat
- (B) Relative ion concentration to voltage
- (C) Conductivity to fluid flow rate
- (D) Partial vapor pressure to fluid density
- (E) Reagent dosage to change in pH

Question 154 – Analytical measurement

Buffer solutions are used with pH probes for the purpose of:

- (A) Purging embedded sodium ions
- (B) Electrode inspection
- (C) Calibration
- (D) Cleaning
- (E) Linearization

Question 155 – Analytical measurement

Flue gas *oxygen* measurement (“O₂ trim”) is important in combustion control systems for the purpose of:

- (A) Reducing sulphur emissions
- (B) Safer shut-downs
- (C) Faster start-ups
- (D) Reducing NO_x emissions
- (E) Minimizing burner noise

Question 156 – Analytical measurement

An aqueous solution has a hydrogen ion concentration of 0.0015 *M*. Calculate the pH of this solution.

- (A) 1.824 pH
- (B) 11.18 pH
- (C) 2.292 pH
- (D) 2.824 pH
- (E) 2.897 pH

Question 157 – Analytical measurement

A *chromatograph* separates and distinguishes different molecule types in a fluid stream by:

- (A) Emitted light spectra
- (B) Atomic mass (weighing)
- (C) Electric charge
- (D) Adsorption time-delay
- (E) Reverse osmosis

Question 158 – Analytical measurement

An *electrodeless*, or *toroidal*, conductivity probe enjoys the following advantage over electrode-type conductivity probes:

- (A) Smaller size
- (B) Lower cost
- (C) Immunity to temperature changes
- (D) Resists fouling
- (E) Greater sensitivity

Question 159 – Analytical measurement

ORP measurement is often used in processes where:

- (A) The addition of an oxidant must be controlled
- (B) The octane value of a liquid fuel is important
- (C) Conductivity of the liquid is negligible
- (D) Pigments are added to a solution to control color
- (E) Precise temperature control is critical

Question 160 – Analytical measurement

According to the *Nernst equation*, the voltage developed by the electrodes will _____ when temperature increases, all other factors remaining the same.

- (A) Remain the same
- (B) Decrease
- (C) Fluctuate
- (D) Increase
- (E) Approach zero

Question 161 – Control valves

When a control valve is installed in a process with nearly constant differential pressure (drop) across the valve, the best trim characteristic to choose for the valve would be:

- (A) Equal percentage
- (B) Quick-opening
- (C) Hyperbolic
- (D) Linear
- (E) Anti-cavitation

Question 162 – Control valves

The correct identities of the four control valve types shown below are (in order from left to right):

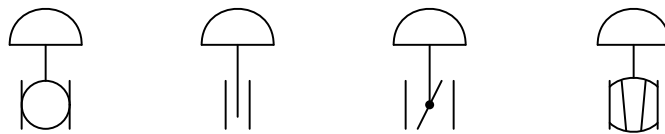

- (A) Globe, Butterfly, Disc, Ball
- (B) Ball, Disc, Butterfly, Globe
- (C) Diaphragm, Gate, Disc, Globe
- (D) Ball, Gate, Butterfly, Plug
- (E) Plug, Slide, Rotary, Ball

Question 163 – Control valves

An air-to-close control valve assembly may be formed with which of these actuator/valve body combinations?

- (A) Direct-acting actuator, reverse-acting valve body
- (B) Direct-acting actuator, direct-acting valve body
- (C) Reverse-acting actuator, reverse-acting valve body
- (D) B or C
- (E) A or B

Question 164 – Control valves

Calculate the necessary C_v rating for a liquid service control valve, given a pressure drop of 19 PSID, a specific gravity of 0.9, and a maximum flow rate of 250 GPM. Assume there will be no flashing or choked flow through the valve.

- (A) 54.41
- (B) 47.66
- (C) 11.84
- (D) 60.46
- (E) 14.62

Question 165 – Control valves

The main purpose of a control valve *positioner* is to:

- (A) Alter the fail-safe status of the valve
- (B) Alter the characterization of the valve
- (C) Improve the precision of the valve
- (D) Increase transmitter accuracy
- (E) Eliminate cavitation in the valve

Question 166 – Control valves

The purpose of valve *packing* is to:

- (A) Help reduce cavitation in the valve trim
- (B) Increase stiction
- (C) Seal process fluid from escaping past the stem
- (D) Cushion the valve against harm during shipment
- (E) Lubricate the valve trim

Question 167 – Control valves

The definition of *split range* control valves implies that they are . . .

- (A) calibrated with complementary ranges.
- (B) designed to be easily disassembled.
- (C) easily re-ranged for different characteristics.
- (D) equipped with quick-acting positioners.
- (E) only used in sets of three.

Question 168 – Control valves

Dual-ported globe valves typically enjoy the following advantage over *single-ported* globe valves:

- (A) Longer service life
- (B) Easier disassembly and maintenance
- (C) Less actuating force required
- (D) Tighter shut-off
- (E) Greater temperature range

Question 169 – Control valves

Cavitation in a control valve is caused by:

- (A) process noise
- (B) vibration in the piping
- (C) the Von Karman effect
- (D) a laminar flow regime
- (E) pressure recovery

Question 170 – Control valves

The proper “fail safe” status of a control valve should always be dictated by:

- (A) economic savings
- (B) the configuration of the positioner
- (C) the nature of the process
- (D) the controller’s tuning
- (E) the controller’s action (direct or reverse)

Question 171 – PID control and tuning

Derivative control action is never used in processes where there is substantial _____.

- (A) Variability
- (B) Gain
- (C) Noise
- (D) Cycling
- (E) Hysteresis

Question 172 – PID control and tuning

_____ processes always require some degree of _____ control action to achieve setpoint.

- (A) Integrating, Derivative
- (B) Integrating, Feedforward
- (C) Self-regulating, Proportional
- (D) Runaway, Linear
- (E) Self-regulating, Integral

Question 173 – PID control and tuning

The reciprocal of *proportional band* is called:

- (A) Reset
- (B) Percent
- (C) Minutes per repeat
- (D) Gain
- (E) Rate

Question 174 – PID control and tuning

“Quarter-wave damping” may be described as:

- (A) a condition of good control where oscillations quickly subside
- (B) a condition of good control where PV approaches SP without overshoot
- (C) a condition of poor control where oscillations continue at constant amplitude
- (D) a condition of poor control where the transmitter is damped by 25%
- (E) a condition of excellent control where there are no oscillations

Question 175 – PID control and tuning

Reset control action is often expressed in units of:

- (A) repeats per minute
- (B) percent
- (C) seconds per rate
- (D) minutes
- (E) time constant ratio (unitless)

Question 176 – PID control and tuning

A proportional band setting of 175% is equivalent to a gain setting of _____.

- (A) 175
- (B) 0.756
- (C) 0.571
- (D) 1.32
- (E) 1.75

Question 177 – PID control and tuning

The open-loop response of a process is shown in the following trend. What sort of process is indicated by this behavior?

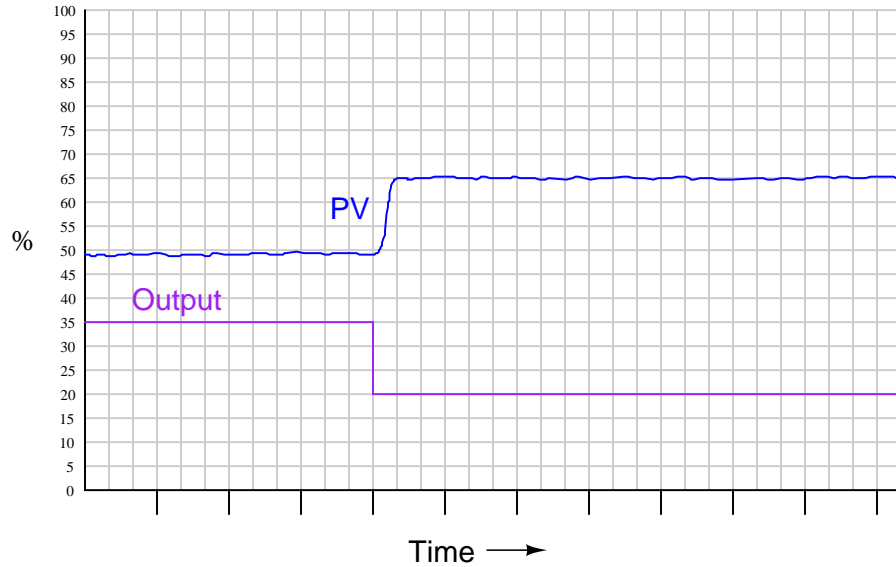

- (A) Proportional
- (B) Integrating
- (C) Self-regulating
- (D) Step-response
- (E) Runaway

Question 178 – PID control and tuning

A condition where integral control action drives the output of a controller into saturation is called:

- (A) self-bias
- (B) repeat
- (C) wind-up
- (D) noise
- (E) offset

Question 179 – PID control and tuning

Purely integrating processes typically respond well to aggressive _____ control action.

- (A) Nonlinear
- (B) Derivative
- (C) Linear
- (D) Proportional
- (E) Integral

Question 180 – PID control and tuning

Process variable *filtering* should be used:

- (A) only on self-regulating processes
- (B) to improve response time
- (C) only on integrating processes
- (D) to dampen noise
- (E) never

Question 181 – Control strategies

Cascade control is characterized by:

- (A) a special relay or function block to compensate for nonlinear process gain
- (B) the presence of a “dead time” relay or function block
- (C) two controllers whose outputs are selected either by high or low value
- (D) one controller providing a setpoint for another controller
- (E) the presence of a “lead/lag” relay or function block

Question 182 – Control strategies

Adaptive gain is used for controlling _____ processes.

- (A) Time-variant
- (B) Dead time
- (C) Fast
- (D) Integrating
- (E) Nonlinear

Question 183 – Control strategies

The three “elements” in a three-element boiler feedwater control system are:

- (A) Steam flow, drum level, and feedwater flow
- (B) Feedwater flow, water conductivity, and steam flow
- (C) Turbidity, feedwater flow, and temperature
- (D) Drum temperature, firing rate, and feedwater flow
- (E) Drum level, water pH, and drum temperature

Question 184 – Control strategies

The purpose of *feedforward* control is to:

- (A) eliminate the need for feedback control in a process
- (B) save energy
- (C) reduce the effect of load variation on the process variable
- (D) reduce the effect of process variable noise on stability
- (E) compensate for dead time and lag time in a process

Question 185 – Control strategies

In a *feedforward* control system, the controller gets its input from the _____.

- (A) Controlled variable
- (B) Load variable
- (C) Manipulated variable
- (D) Inferred variable
- (E) Dynamic variable

Question 186 – Control strategies

Ratio control is where:

- (A) a “wild flow” variable sets the gain of the controller
- (B) fuel must be precisely rationed for economy
- (C) process data is communicated in a digital format
- (D) the rate of one variable must remain fixed over time
- (E) one variable is controlled in proportion to another

Question 187 – Control strategies

The following P&ID shows a/an _____ control strategy:

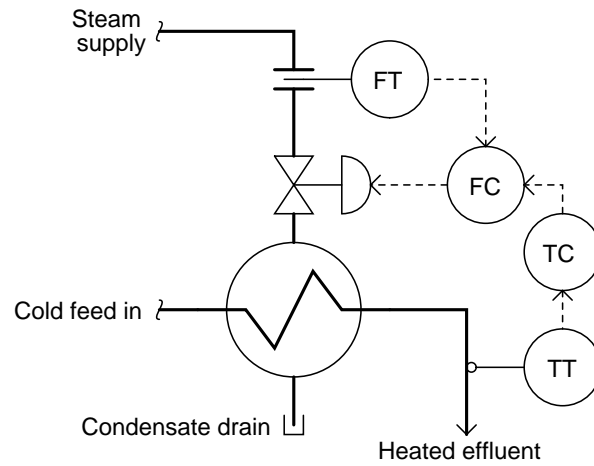

- (A) Adaptive gain
- (B) Ratio
- (C) Model predictive
- (D) Feedforward
- (E) Cascade

Question 188 – Control strategies

The *slave* controller in a cascade control system must always be tuned:

- (A) in manual mode
- (B) slower than the master
- (C) with greater filtering than the master
- (D) after the master
- (E) before the master

Question 189 – Control strategies

The following P&ID shows a/an _____ control strategy:

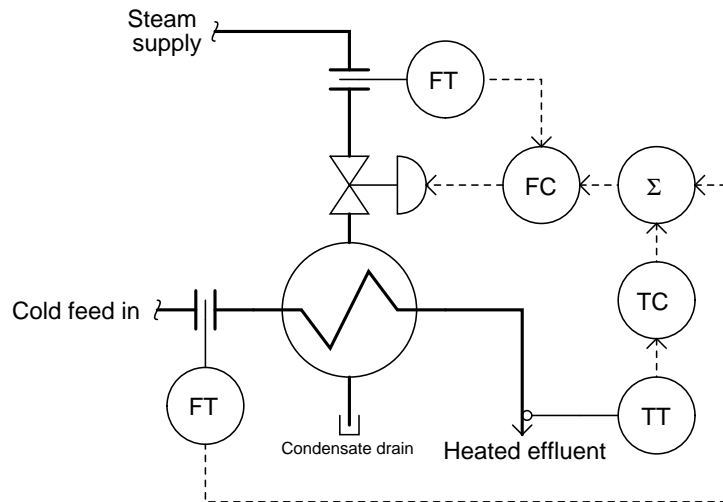

- (A) Ratio
- (B) Feedforward with trim
- (C) Cascade
- (D) Override
- (E) Two-element

Question 190 – Control strategies

Lead/lag compensation, sometimes called “dynamic compensation,” is commonly used to:

- (A) equalize load and manipulated variable lags in a feedforward system
- (B) improve stability by changing controller gain over time
- (C) filter noise from the process variable signal in a feedforward system
- (D) overcome dead time by duplicating the process lags on the setpoint signal
- (E) prevent integral windup by placing limits on the manipulated variable signal

Question 191 – Instrumentation diagrams

Identify what type of diagram this is:

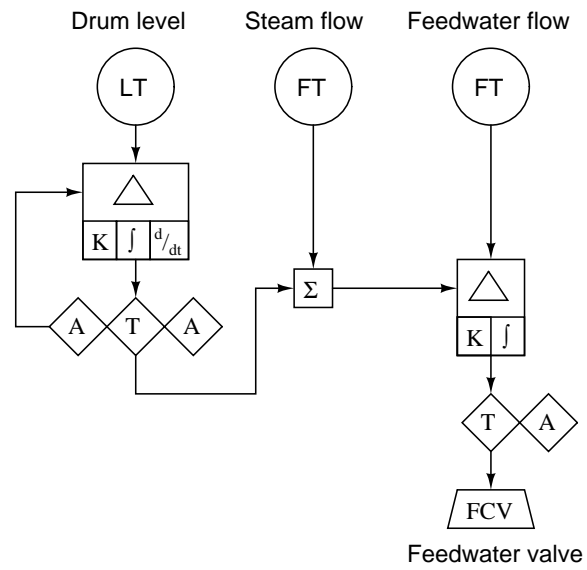

- (A) Wiring diagram
- (B) Isometric drawing
- (C) P&ID
- (D) Loop diagram
- (E) SAMA diagram

Question 192 – Instrumentation diagrams

Identify what type of diagram this is:

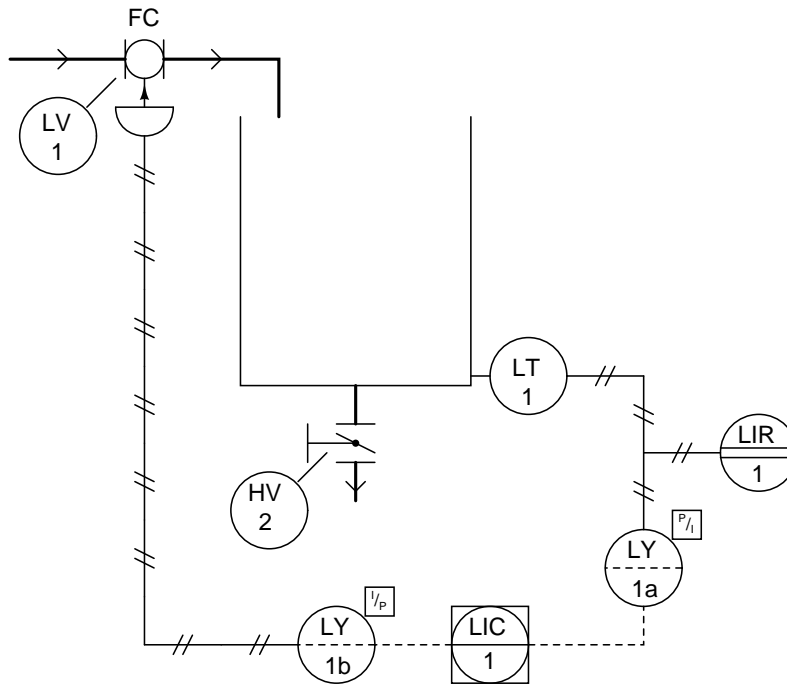

- (A) Wiring diagram
- (B) Isometric drawing
- (C) P&ID
- (D) Loop diagram
- (E) SAMA diagram

Question 193 – Instrumentation diagrams

According to this diagram, the controller is _____, and it is located _____:

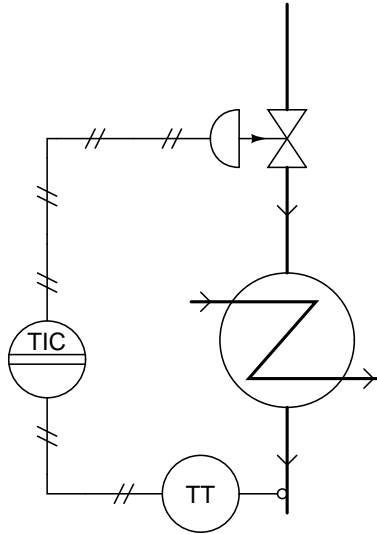

- (A) Electronic, on the front of the main control panel
- (B) Pneumatic, in the field (process) area
- (C) Pneumatic, on the front of the main control panel
- (D) Pneumatic, on the front of a secondary control panel
- (E) Electronic, behind the main control panel

Question 194 – Instrumentation diagrams

Identify the following instrumentation (P&ID and loop diagram) line types, from left to right:



- (A) electric, pneumatic, digital network, filled system
- (B) pneumatic, electric, hydraulic, mechanical link
- (C) electric (on/off), electric (analog), pneumatic, digital network
- (D) pneumatic, mechanical link, hydraulic, capillary
- (E) pneumatic, electric, capillary, hydraulic

Question 195 – Instrumentation diagrams

If the pneumatic tube in this diagram were to suddenly break in two pieces, what would be the effect on the process variable?

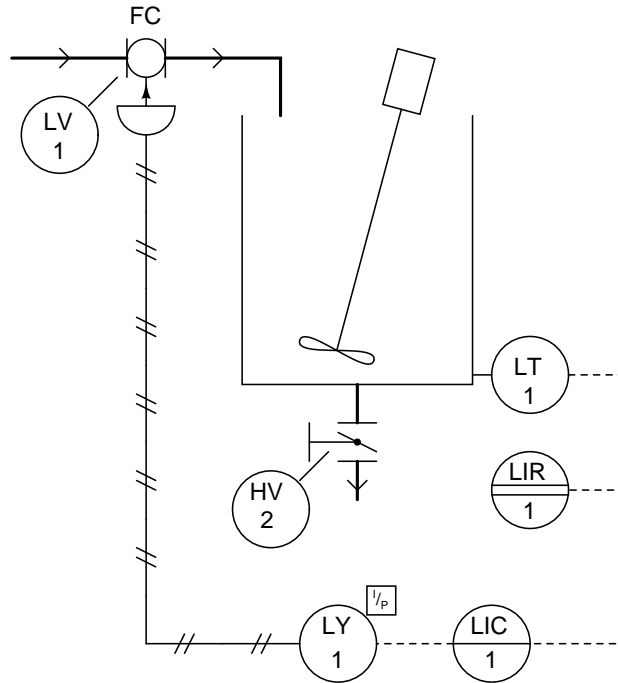

- (A) It would remain the same
- (B) It would decrease
- (C) It would become noisier
- (D) It would become less noisy
- (E) It would increase

Question 196 – Instrumentation diagrams

If the gas flow through FT-42 is 1200 SCFM, how much electric current is going through cable 23 and through cable 27?

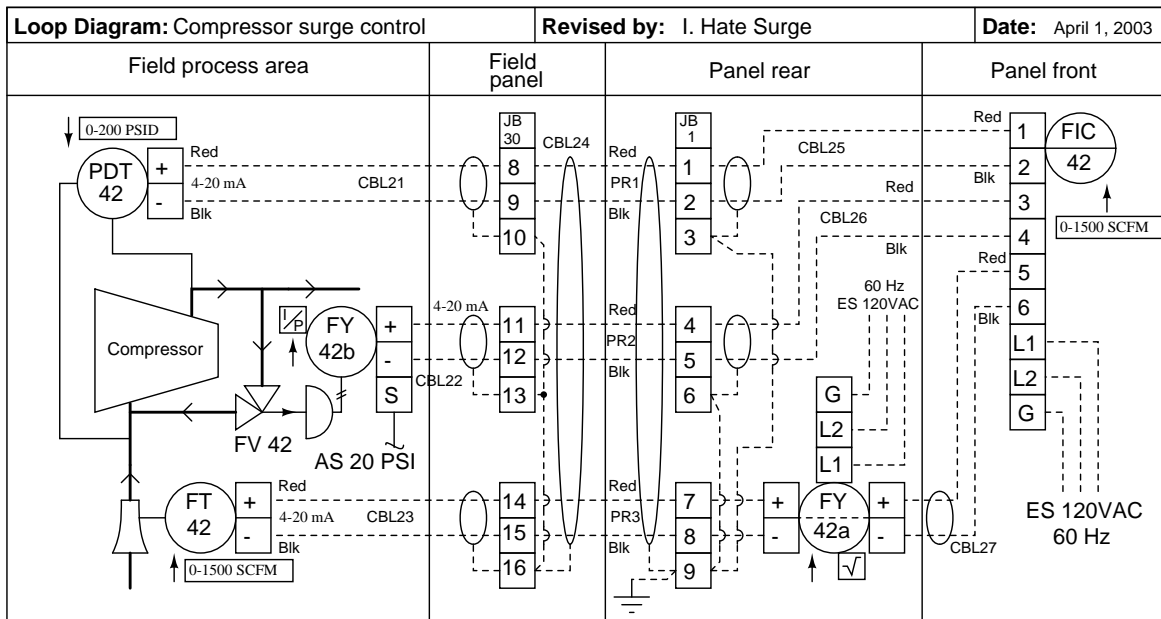

- (A) $I_{CBL23} = 14.2 \text{ mA}$, $I_{CBL27} = 14.2 \text{ mA}$
- (B) $I_{CBL23} = 14.2 \text{ mA}$, $I_{CBL27} = 16.8 \text{ mA}$
- (C) $I_{CBL23} = 16.8 \text{ mA}$, $I_{CBL27} = 16.8 \text{ mA}$
- (D) $I_{CBL23} = 16.8 \text{ mA}$, $I_{CBL27} = 14.2 \text{ mA}$
- (E) $I_{CBL23} = 16.8 \text{ mA}$, $I_{CBL27} = 18.3 \text{ mA}$

Question 197 – Instrumentation diagrams

Calculate the voltage between terminals 15 and 16 of TB27 when the measured flow rate is 106 GPM. Assume a loop power supply voltage of exactly 24.00 volts, and negligible wire resistance:

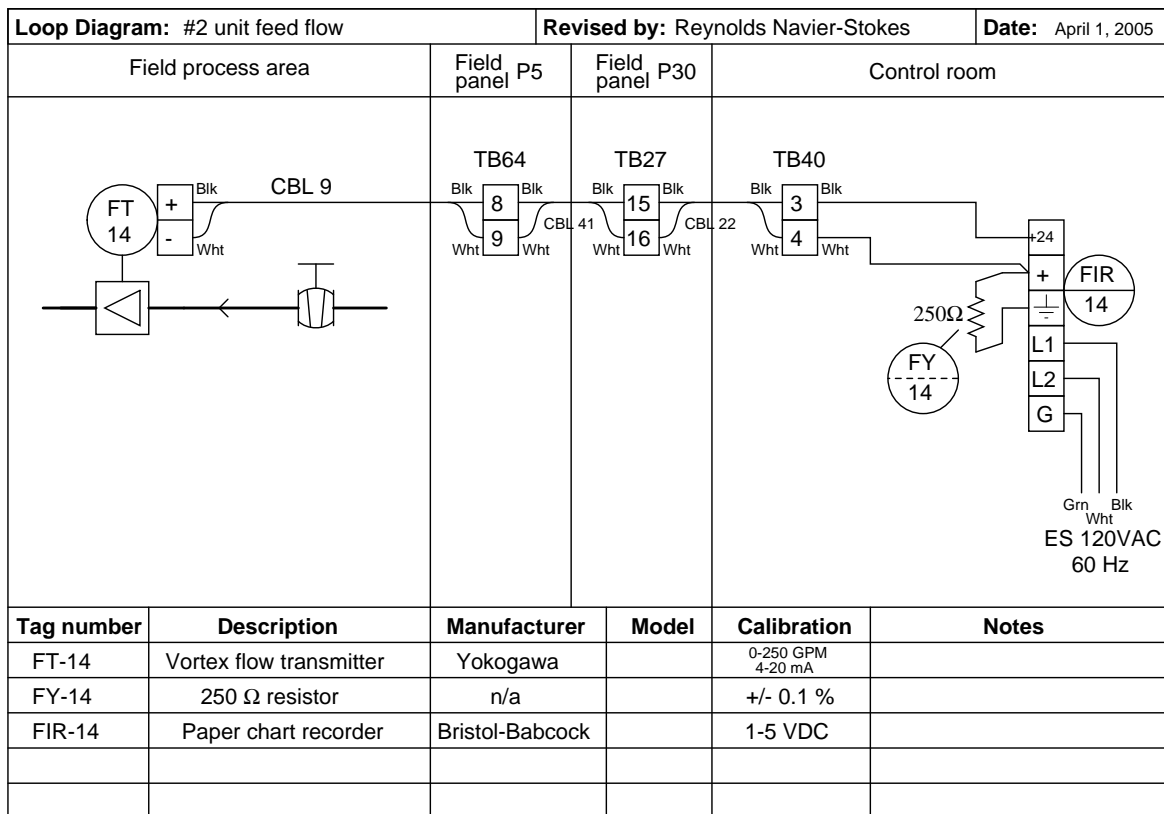

- (A) 26.70 volts
- (B) 22.28 volts
- (C) 21.30 volts
- (D) 24.00 volts
- (E) 2.696 volts

Question 198 – Instrumentation diagrams

If the thermocouple fails open, what will happen?

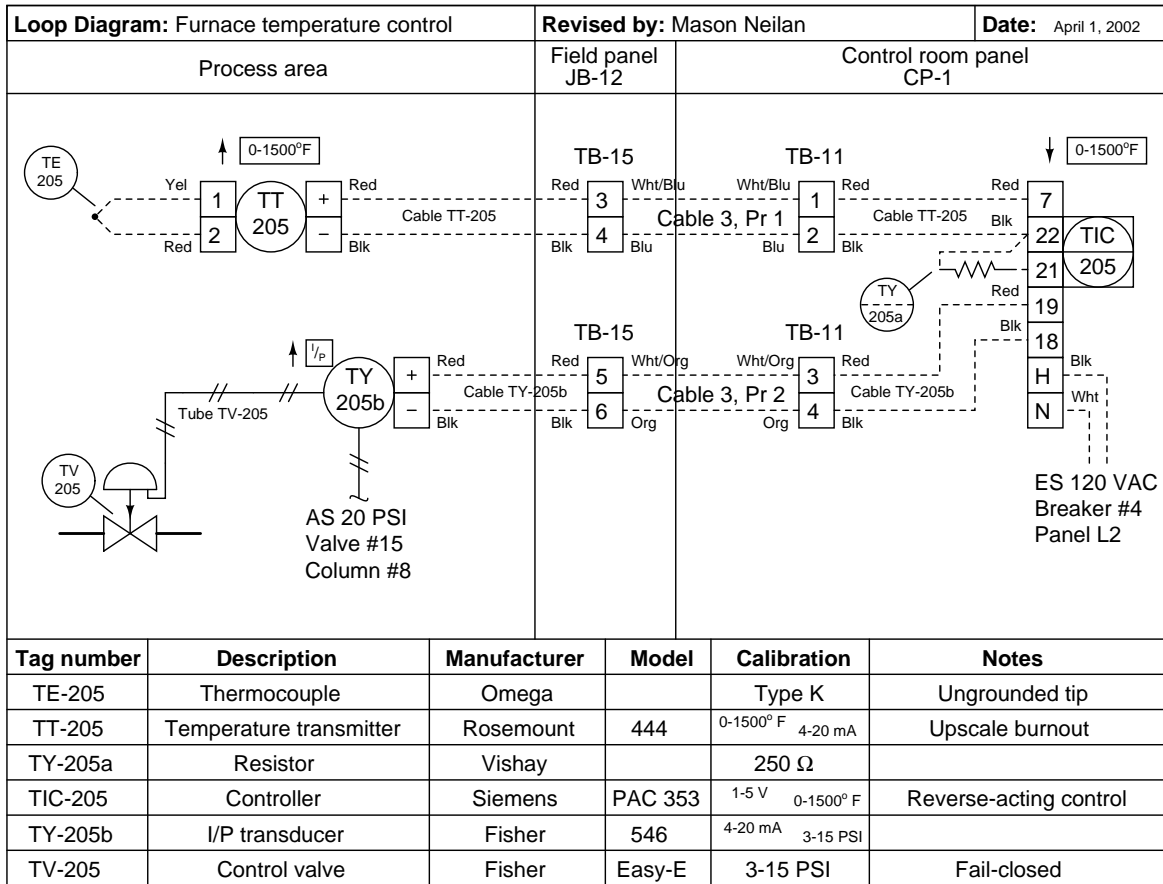

- (A) Valve TV-205 will close shut, making the process warm up
- (B) Valve TV-205 will close shut, making the process cool down
- (C) Valve TV-205 will hold position, stabilizing the process
- (D) Valve TV-205 will open wide, making the process cool down
- (E) Valve TV-205 will open wide, making the process warm up

Question 199 – Instrumentation diagrams

What kind of device provides the setpoint for the analytical indicating controller in this diagram?

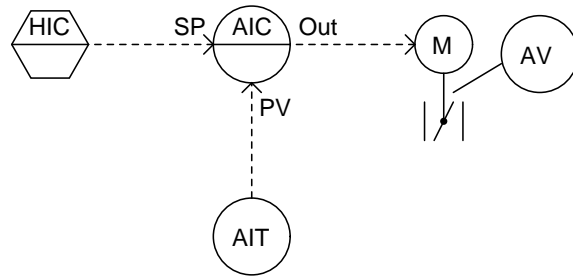

- (A) A mathematical relay
- (B) Another panel-mounted controller
- (C) A computer
- (D) A programmable logic controller (PLC)
- (E) A pneumatic hand station

Question 200 – Instrumentation diagrams

What sort of alarm function is provided by the controller in this diagram?

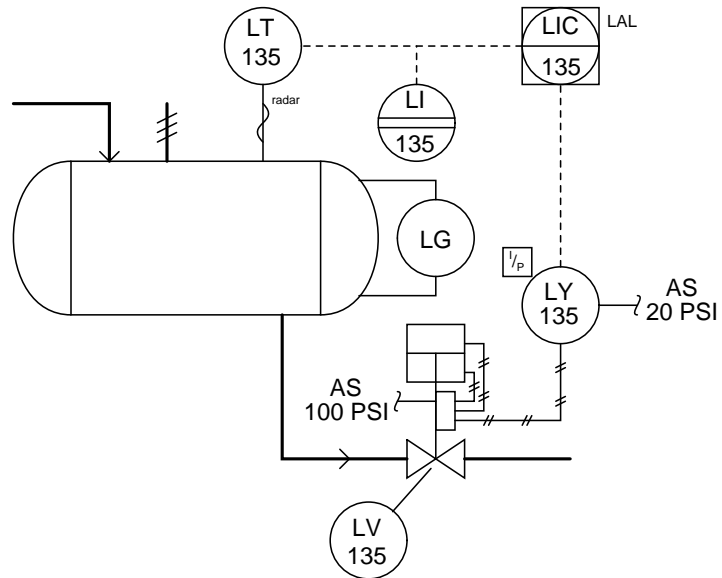

- (A) High-flow alarm
- (B) Low-level alarm
- (C) High-temperature alarm
- (D) Low-flow alarm
- (E) High-level alarm

Question 201 – Programmable logic controllers

The acronym *PLC* stands for:

- (A) Pressure Load Control
- (B) Pneumatic Logic Capstan
- (C) PID Loop Controller
- (D) Pressure Loss Chamber
- (E) Programmable Logic Controller

Question 202 – Programmable logic controllers

Ladder logic programming consists primarily of:

- (A) Logic gate symbols with connecting lines
- (B) Function blocks with connecting lines
- (C) Text-based code
- (D) Hieroglyphics
- (E) Virtual relay contacts and coils

Question 203 – Programmable logic controllers

In a PLC, the *scan time* refers to the amount of time in which . . .

- (A) the technician enters the program
- (B) timers and counters are indexed by
- (C) one “rung” of ladder logic takes to complete
- (D) transmitted data communications must finish
- (E) the entire program takes to execute

Question 204 – Programmable logic controllers

Identify the problem in this motor control PLC program:

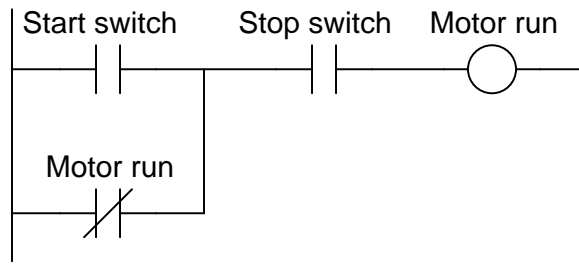

- (A) Coil
- (B) Start contact
- (C) Stop contact
- (D) Seal-in contact
- (E) Power source

Question 205 – Programmable logic controllers

The Boolean representation of this PLC program is:

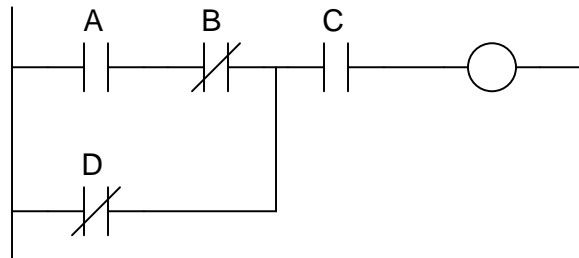

- (A) $A\bar{B}C + \bar{D}$
- (B) $C + (A + \bar{B})\bar{D}$
- (C) $\bar{C} + D(\bar{A} + B)$
- (D) $C(A\bar{B} + \bar{D})$
- (E) $A\bar{B}C + B\bar{D}$

Question 206 – Programmable logic controllers

The difference between *online* and *offline* PLC programming is . . .

- (A) whether the PLC is running or stopped
- (B) whether the programming PC has internet connectivity
- (C) where the edited program resides
- (D) the type of programming cable used
- (E) the type of programmer used

Question 207 – Programmable logic controllers

In PLC programming, a *retentive* function is one that:

- (A) Defaults to the “on” state
- (B) Comes last in the program
- (C) Defaults to the “off” state
- (D) Is not reset after a power cycle
- (E) Cannot be edited or deleted

Question 208 – Programmable logic controllers

What is the largest integer number that a PLC counter function can reach if it uses an 8 bit register?

- (A) 128
- (B) 255
- (C) 256
- (D) -127
- (E) 127

Question 209 – Programmable logic controllers

An *OR* function implemented in ladder logic uses:

- (A) Normally-open contacts in parallel
- (B) Normally-closed contacts in series
- (C) Normally-open contacts in series
- (D) A single normally-closed contact
- (E) Normally-closed contacts in parallel

Question 210 – Programmable logic controllers

A good application for a *timed interrupt* in a PLC program would be:

- (A) A communications function block
- (B) A math function block
- (C) A motor start/stop rung
- (D) A “watchdog” timer
- (E) A PID function block

Question 211 – Digital control systems

The acronym *DCS* stands for:

- (A) DeltaV Console Services
- (B) Direct Cascade Sequencing
- (C) Differential Concentration Switch
- (D) Distributive Control System
- (E) Digital Control System

Question 212 – Digital control systems

Many digital control systems utilize *Ethernet* as a communications network, because . . .

- (A) no terminating resistors are necessary
- (B) it is robust and inexpensive
- (C) speed is not affected by traffic
- (D) it is a wireless network standard
- (E) it is fully deterministic

Question 213 – Digital control systems

Resolution refers to _____ in the analog-to-digital conversion portion of a digital control system.

- (A) the number of active bits
- (B) the analog signal range
- (C) how determined the designer was
- (D) the speed of analog signal sampling
- (E) the probability of hardware failure

Question 214 – Digital control systems

A *checksum* is used for the purpose of _____ in digital systems.

- (A) math calculations
- (B) diagnostic monitoring
- (C) error detection
- (D) time-stamping data
- (E) power monitoring

Question 215 – Digital control systems

A typical use for an *integer* variable in a digital control system is:

- (A) Representing single switch status
- (B) Representing power supply voltage
- (C) Trigonometric math operations
- (D) Exponential math operations
- (E) Counting discrete events

Question 216 – Digital control systems

TIA/EIA-485 (formerly known as RS-485) is a digital communication standard with the following traits:

- (A) Differential voltage signaling, multipoint
- (B) Single-ended voltage signaling, multidrop
- (C) Frequency Shift Key (FSK) signaling, superimposed on analog 4-20 mA
- (D) Manchester encoding, multidrop
- (E) Mark-and-space signaling, point-to-point

Question 217 – Digital control systems

FOUNDATION Fieldbus is unique in that:

- (A) It has always been the leading fieldbus standard
- (B) Data communication is entirely deterministic
- (C) Control algorithms may reside in the field devices
- (D) Power and data share the same wires
- (E) Diagnostic data is communicated as well as process data

Question 218 – Digital control systems

A *watchdog timer* is a device or a programmed routine used for what purpose in a digital control system?

- (A) To interrupt normal program flow and address an immediate need
- (B) To check for errors in data communications
- (C) To monitor the operation of the microprocessor
- (D) To provide time delays for critical functions
- (E) To signal the start of a new program cycle

Question 219 – Digital control systems

Digital control systems are generally superior to analog control systems, but they are always worse with regard to:

- (A) Diagnostics
- (B) User-friendliness
- (C) Flexibility
- (D) Speed
- (E) Noise immunity

Question 220 – Digital control systems

A *triple modular redundant* (TMR) digital control system would be typically used for what purpose?

- (A) To control a potentially dangerous process
- (B) To save energy (compared to other control systems)
- (C) To increase response speed for fast processes
- (D) To save money (compared to other control systems)
- (E) To minimize routine maintenance requirements

Answers

Answer 1

(D) Prevent injury by securing all energy sources in a system

Answer 2

(D) CPR (Cardio-Pulmonary Resuscitation)

Answer 3

(C) Alert professional emergency responders

Answer 4

(D) Reduce the concentration of particulates in the air you breathe

Answer 5

(A) There is insufficient blood delivered to the body's cells

Answer 6

(B) A company safety inspector has certified it

Answer 7

(D) Discomfort in the chest and/or upper body

Answer 8

(B) Hot and dry skin, inability to drink, vomiting, confusion

Answer 9

(C) A discharge of high electrical current through open air

Answer 10

(D) The circuit must be broken (opened)

Answer 11

(C) $x = aby$

Answer 12

(E) $x = \frac{a}{\sqrt{b}}$

Answer 13

(C) $y = \frac{-x}{2} + 3$

Answer 14

(B) $y = x^2$

Answer 15

(E) $x = 2 ; y = -1$

Answer 16

(B) 1:12

Answer 17

(D) $ab^{-7}c^3x^2y^2$

Answer 18

(B) $x^{-3/2}$

Answer 19

(C) 91.8

Answer 20

(A) $(x + 3)(x - 4)$

Answer 21

(C) Opposite divided by hypotenuse

Answer 22

(A) 10.3

Answer 23

(A) 57.99°

Answer 24

(C) 45°

Answer 25

(E) Tangent

Answer 26

(B) $13.342 \angle -103^\circ$

Answer 27

(E) Amplitude and phase shift

Answer 28

(A) 11.06

Answer 29

(B) 1.309 radians

Answer 30

(E) 23.09 meters

Answer 31

(C) 125

Answer 32

(C) greater than 7

Answer 33

(E) accelerates a chemical reaction without being consumed

Answer 34

(B) 12.03 liters

Answer 35

(E) Endothermic

Answer 36

(C) 4,500 joules

Answer 37

(A) 11,760 joules

Answer 38

(E) 19.18°

Answer 39

(D) greater than the weight of the sign

Answer 40

(C) greater than the latent heat of fusion

Answer 41

(B) 3.0 volts

Answer 42

(D) 7.835 mA

Answer 43

(A) 9.656 k Ω

Answer 44

(A) 2.143 k Ω

Answer 45

(D) 441.5 μ A

Answer 46

(E) 5

Answer 47

(C) -13.5 volts

Answer 48

(B) 16 volts

Answer 49

(E) 160 mA ← (right to left)

Answer 50

(B) + 0.5 volts - (positive on left, negative on right)

Answer 51

(E) Current will increase

Answer 52

(C) complementary reactances become equal and opposite

Answer 53

(B) $I_{source} = 187.5 \text{ mA}$ $I_{load} = 72.73 \text{ mA}$

Answer 54

(D) Trigger

Answer 55

(B) 27.96 dB

Answer 56

(B) 0.819

Answer 57

(A) 400 Hz

Answer 58

(A) 17.31 volts

Answer 59

(E) The cable appears to a pulse signal as a 75 ohm load

Answer 60

(E) Blocks high-frequency signals from passing through

Answer 61

(D) 18.04 amps

Answer 62

(D) More power may be transmitted using less copper (wire)

Answer 63

(A) A rotating magnetic field

Answer 64

(E) They potentially save energy

Answer 65

(A) Latching the motor in the “run” state

Answer 66

(E) Protect the motor against mild overcurrent conditions

Answer 67

(D) 7.205 kV

Answer 68

(D) 15.32 hp

Answer 69

(A) its speed is constant

Answer 70

(E) superior low-speed torque is needed

Answer 71

(A) trivalent

Answer 72

(C) Cathode and anode

Answer 73

(B) 1 = Emitter ; 2 = Base ; 3 = Collector

Answer 74

(A) measure magnetic field strength

Answer 75

(A) 9.31 volts

Answer 76

(D) -5.96 volts

Answer 77

(A) 26.9 volts

Answer 78

(E) turn off

Answer 79

(A) change motor direction

Answer 80

(E) Boost voltage ; same output polarity as input

Answer 81

(B) 1011001001111000

Answer 82

(E) 00110001

Answer 83

(E) $\overline{B} + \overline{AC}$

Answer 84

(C) $B\overline{C}$

Answer 85

(C) $Q = 0$ and $\overline{Q} = 1$

Answer 86

(D) Eliminating false switching events

Answer 87

(A) The negative power supply rail of a bipolar transistor circuit

Answer 88

(A) Representing alphanumeric characters

Answer 89

(B) latch

Answer 90

(A) Share an output line with another gate

Answer 91

(B) transmitter, controller, I/P transducer, and control valve

Answer 92

(C) Negative feedback

Answer 93

(E) A valve

Answer 94

(A) Ground the shield conductor only at one end of the cable

Answer 95

(E) 4 to 20 milliamps DC

Answer 96

(D) The target value for the measured variable

Answer 97

(B) Torque tube

Answer 98

(A) Move the control valve further closed

Answer 99

(A) Process variable

Answer 100

(B) Allow a human operator to take control of the process

Answer 101

(B) Zero error

Answer 102

(C) Linearity error

Answer 103

(C) Establish a baseline for comparison, to detect calibration drift

Answer 104

(B) Set the pressure at 50 PSI and move the switch adjustment down until it actuates

Answer 105

(D) Zero

Answer 106

(D) +/- 0.08 mA

Answer 107

(A) 9.6 mA

Answer 108

(C) 8.325 pH

Answer 109

(B) In the text section of a loop diagram sheet

Answer 110

(E) Has a microprocessor built inside

Answer 111

(C) 0.7737 PSIG

Answer 112

(A) Orifice plate

Answer 113

(B) 1082.3 PSI

Answer 114

(C) Head

Answer 115

(B) Decrease

Answer 116

(E) Close one block valve, open equalizing valve, close other block valve, open bleed

Answer 117

(A) A high rate of flow from left to right (top to bottom through the vessel)

Answer 118

(E) 8.00 "W.C.

Answer 119

(A) Turn the screw (located near the bellows)

Answer 120

(A) Lamp 1 off, Lamp 2 on, Solenoid on

Answer 121

(D) Differential pressure transmitter

Answer 122

(E) It isolates the pressure transmitter from the process fluid

Answer 123

(C) We will need to change the transmitter's *zero*

Answer 124

(E) 4.363 pounds

Answer 125

(D) LRV = 84 "H₂O ; URV = 444 "H₂O

Answer 126

(D) The transmitter is located below the 0% liquid level mark

Answer 127

(D) Displacer

Answer 128

(E) Dielectric constant

Answer 129

(D) Electrically conductive

Answer 130

(D) 4.167 PSI

Answer 131

(A) Type S

Answer 132

(B) Red

Answer 133

(A) RTD

Answer 134

(C) 544.3 K

Answer 135

(E) Zero

Answer 136

(A) Protective tube for a temperature sensing element

Answer 137

(B) The reference junction generates a temperature-dependent voltage

Answer 138

(B) The heat required to make a substance change phase

Answer 139

(E) Outer sheath color

Answer 140

(A) Chromel and Alumel

Answer 141

(C) Turbine

Answer 142

(E) Potential and kinetic energies in a flow stream

Answer 143

(E) Velocity increases and pressure decreases

Answer 144

(A) Vortex shedding

Answer 145

(E) Fully-developed turbulent flow

Answer 146

(D) Oil

Answer 147

(B) Gas flow

Answer 148

(D) Insufficient straight-pipe length exists

Answer 149

(A) 0 to 34.03 " H₂O

Answer 150

(C) Thermal

Answer 151

(C) Hydrogen ion activity

Answer 152

(A) Acidic

Answer 153

(B) Relative ion concentration to voltage

Answer 154

(C) Calibration

Answer 155

(D) Reducing NO_x emissions

Answer 156

(D) 2.824 pH

Answer 157

(D) Adsorption time-delay

Answer 158

(D) Resists fouling

Answer 159

(A) The addition of an oxidant must be controlled

Answer 160

(D) Increase

Answer 161

(D) Linear

Answer 162

(D) Ball, Gate, Butterfly, Plug

Answer 163

(D) B or C

Answer 164

(A) 54.41

Answer 165

(C) Improve the precision of the valve

Answer 166

(C) Seal process fluid from escaping past the stem

Answer 167

(A) calibrated with complementary ranges.

Answer 168

(C) Less actuating force required

Answer 169

(E) pressure recovery

Answer 170

(C) the nature of the process

Answer 171

(C) Noise

Answer 172

(E) Self-regulating, Integral

Answer 173

(D) Gain

Answer 174

(A) a condition of good control where oscillations quickly subside

Answer 175

(A) repeats per minute

Answer 176

(C) 0.571

Answer 177

(C) Self-regulating

Answer 178

(C) wind-up

Answer 179

(D) Proportional

Answer 180

(D) to dampen noise

Answer 181

(D) one controller providing a setpoint for another controller

Answer 182

(E) Nonlinear

Answer 183

(A) Steam flow, drum level, and feedwater flow

Answer 184

(C) reduce the effect of load variation on the process variable

Answer 185

(B) Load variable

Answer 186

(E) one variable is controlled in proportion to another

Answer 187

(E) Cascade

Answer 188

(E) before the master

Answer 189

(B) Feedforward with trim

Answer 190

(A) equalize load and manipulated variable lags in a feedforward system

Answer 191

(E) SAMA diagram

Answer 192

(C) P&ID

Answer 193

(D) Pneumatic, on the front of a secondary control panel

Answer 194

(E) pneumatic, electric, capillary, hydraulic

Answer 195

(B) It would decrease

Answer 196

(B) $I_{CBL23} = 14.2 \text{ mA}$, $I_{CBL27} = 16.8 \text{ mA}$

Answer 197

(C) 21.30 volts

Answer 198

(B) Valve TV-205 will close shut, making the process cool down

Answer 199

(C) A computer

Answer 200

(B) Low-level alarm

Answer 201

(E) Programmable Logic Controller

Answer 202

(E) Virtual relay contacts and coils

Answer 203

(E) the entire program takes to execute

Answer 204

(D) Seal-in contact

Answer 205

(D) $C(\overline{AB} + \overline{D})$

Answer 206

(C) where the edited program resides

Answer 207

(D) Is not reset after a power cycle

Answer 208

(B) 255

Answer 209

(A) Normally-open contacts in parallel

Answer 210

(E) A PID function block

Answer 211

(D) Distributive Control System

Answer 212

(B) it is robust and inexpensive

Answer 213

(A) the number of active bits

Answer 214

(C) error detection

Answer 215

(E) Counting discrete events

Answer 216

(A) Differential voltage signaling, multipoint

Answer 217

(C) Control algorithms may reside in the field devices

Answer 218

(C) To monitor the operation of the microprocessor

Answer 219

(D) Speed

Answer 220

(A) To control a potentially dangerous process
