

Instrument calibration tables

This worksheet and all related files are licensed under the Creative Commons Attribution License, version 1.0. To view a copy of this license, visit <http://creativecommons.org/licenses/by/1.0/>, or send a letter to Creative Commons, 559 Nathan Abbott Way, Stanford, California 94305, USA. The terms and conditions of this license allow for free copying, distribution, and/or modification of all licensed works by the general public.

Questions

Question 1

Suppose you had a current-to-pressure (“I/P”) transducer with an output range of 3 to 15 PSI and an input range of 4 to 20 mA. The following calibration table shows several input signal levels and their corresponding percentages of span and output pressures:

Input signal applied (mA)	Percent of span (%)	Output pressure (PSI)
6.88	18	5.16
5.1	6.88	3.83
12.8	55	9.6
17.44	84	13.08
6.53	15.83	4.9

While the calculations for obtaining percent and output pressure (PSI) from input current (mA) values are not very complex, they can be tedious. A powerful computer-based tool for relieving this tedium is a type of application called a *spreadsheet*. A very common example of spreadsheet software is Microsoft *Excel* (although other spreadsheet programs exist, some of them free!).

A spreadsheet program presents a screen full of rectangular *cells* into which text, numerical values, and mathematical formulae may be entered. Each cell is “addressed” by a system of row and column designators, traditionally numbers for rows and letters for columns (like the classic game of “Battleship” where coordinates on a grid-map are called out by letter and number combination) but a more modern convention designates both rows and columns by number.

We may set up a spreadsheet to calculate percentage values for this I/P based on input currents as follows. The yellow and blue cell shading (color fill) shown in this example is entirely optional, but helps to distinguish number-entry fields from calculated-value fields (the number in the yellow cell R2C1 is the milliamp value you type in to the spreadsheet, while the number in the blue cell R2C3 is the PSI value calculated by the spreadsheet):

	1	2	3	4	5
1	Input (mA)		Percent		
2	6.88		18.0		
3					
4					
5					

What follows is a list of cell entries needed to create the spreadsheet display you see above:

- Cell R1C1: Input (mA)
- Cell R2C1: 6.88
- Cell R1C3: Percent
- Cell R2C3: = (R2C1 - 4) / 16 (select “%” display formatting)

The text inside cells R1C1 and R1C3 is not essential for the spreadsheet to function – like the color shading, they merely serve as labels to help describe what the number values mean. The formula entered into cell R2C3 begins with an equals sign (=), which tells the spreadsheet to regard it as a formula rather than as text to be displayed verbatim as in R1C1 and R1C3. Note how the formula references the numerical value located in the “row 2 column 1” cell by calling it “R2C1”. This allows the user to enter different values into cell R2C1, and the spreadsheet will automatically re-calculate the percentage for each entered mA value. Thus, if you were to edit the contents of cell R2C1 to hold 12.8 instead of 6.88, the value shown in cell R2C3 would update to display 55.0 instead of 18.0 as it does now.

Your first task here is to start up a spreadsheet program and enter what is shown above, then validate the accuracy of your work by entering several different current (milliamp) values and checking that the percentages for each are calculated correctly by the spreadsheet.

Now that you have successfully created this spreadsheet, add the appropriate entries into cells R1C5 and R2C5 so that it also calculates the appropriate output pressure for the I/P, for any arbitrary input current entered into cell R2C1. When complete, your modified spreadsheet should look something like this:

	1	2	3	4	5
1	Input (mA)		Percent		Output (PSI)
2	6.88		18.0		5.16
3					
4					
5					

Show what entries you had to place into cells R1C5 and R2C5 to make this spreadsheet work.

Suggestions for Socratic discussion

- Identify the text character used to represent *division* in the formula shown in cell R2C3. What is the appropriate character to represent *multiplication*?
- Explain why parentheses are used in the formula in cell R2C3. *Hint: a good problem-solving approach for answering this question is to analyze what would happen if the parentheses were not there!*
- Explain what would happen if cell R2C3 were not configured to display in *percent*.
- There is more than one correct formula to enter into cell R2C5 to properly calculate the output pressure in PSI. One formula references the percentage value (located at R2C3), while the other formula references the milliamp value (located at R2C1). Compare these two formulae, and explain which one makes more sense to you.
- Explain how a spreadsheet is such a powerful mathematical tool for performing “tedious” calculations such as instrument input/output responses. Can you think of any other practical uses for a spreadsheet?

file i01626

Question 2

A tachogenerator is used to measure the rotary speed of a machine. Its calibrated range is 0 to 1500 RPM (revolutions per minute) and its corresponding signal output is 0 to 10 volts DC. Given these range values, calculate the output voltages for the following input shaft speeds, and then describe how you were able to correlate the different speeds to output voltage values:

Shaft speed (RPM)	Output voltage (volts DC)
100	
350	
500	
750	
890	
975	
1230	
1410	
1500	

[file i00085](#)

Question 3

Suppose you wish to calibrate an electronic pressure transmitter to an input range of 0 to 50 PSI, with an output range of 4 to 20 mA. Complete the following calibration table showing the proper test pressures and the ideal output signal levels at those pressures:

Input pressure applied (PSI)	Percent of span (%)	Output signal (mA)
	0	
	25	
	50	
	75	
	100	

[file i01763](#)

Question 4

Suppose you wish to calibrate an electronic pressure transmitter to an input range of 0 to 200 PSI, with an output range of 4 to 20 mA. Complete the following calibration table showing the proper test pressures and the ideal output signal levels at those pressures:

Input pressure applied (PSI)	Percent of span (%)	Output signal (mA)
	0	
	25	
	50	
	75	
	100	

[file i01764](#)

Question 5

In instrumentation parlance, a *transducer* is a calibrated device used to convert one standardized signal into another standardized signal. One very common form of transducer is an *I/P transducer*, which converts an electric current signal into a pneumatic pressure signal:

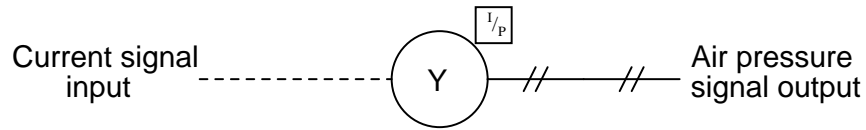

The symbols shown above are standard for process and instrumentation diagrams (P&ID's), where an electric cable is shown as a dashed line, a pneumatic pipe or tube shown as a line with double hash-marks periodically drawn through it, and the instrument is a circle with letters (in this case, "Y", representing a signal relay, computing element, transducer, or converter).

The most popular range for electric current signals is 4 to 20 mA DC. The most common range for pneumatic (air pressure) signals is 3 to 15 PSI. Therefore, the most common type of I/P transducer has an input range of 4-20 mA and an output range of 3-15 PSI. Both of these ranges are there to represent some measured or manipulated quantity in an instrument system. That is, 0% of range will be represented by a 4 mA input signal to the I/P, and a 3 PSI output signal; 100% of range will be represented by a 20 mA input signal and a 15 PSI output signal; 50% range will be represented by a 12 mA input and a 9 PSI output.

Complete all the missing data in the following calibration table for this I/P transducer, and then describe how you were able to correlate the different percentages of range with specific current and pressure signal values:

Input current (mA)	Percent of range (%)	Output pressure (PSI)
4	0	3
	10	
	20	
	25	
	30	
	40	
12	50	9
	60	
	70	
	75	
	80	
	90	
20	100	15

Challenge: build a computer spreadsheet that calculates all current and pressure values from given percentages.

[file i00084](#)

Question 6

Suppose you wish to calibrate a current-to-pressure (“I/P”) transducer to an output range of 3 to 15 PSI, with an input range of 4 to 20 mA. Complete the following calibration table showing the proper test pressures and the ideal input signal levels at those pressures:

Input signal applied (mA)	Percent of span (%)	Output pressure (PSI)
	35	
	80	
	95	

file i01625

Question 7

An electronic level transmitter has a calibrated range of 0 to 2 feet, and its output signal range is 4 to 20 mA. Complete the following table of values for this transmitter, assuming perfect calibration (no error). Be sure to show your work!

Measured level (feet)	Percent of span (%)	Output signal (mA)
1.6		
		7.1
	40	

file i00032

Question 8

A pneumatic level transmitter has a calibrated range of 0 to 5 feet, and its output signal range is 3 to 15 PSI. Complete the following table of values for this transmitter, assuming perfect calibration (no error). Be sure to show your work!

Measured level (feet)	Percent of span (%)	Output signal (PSI)
3.2		
		4
	50	
2.4		
		11.3
	18	

file i00097

Question 9

Suppose you wish to calibrate an electronic pressure transmitter to an input range of 0 to 50 inches of water, with an output range of 4 to 20 mA. Complete the following calibration table showing the proper test pressures and the ideal output signal levels at those pressures:

Input pressure applied (" W.C.)	Percent of span (%)	Output signal (mA)
	5	
	33	
	61	

[file i00462](#)

Question 10

An electronic pressure transmitter has a calibrated range of 0 to 200 inches of mercury, and its output signal range is 4 to 20 mA. Complete the following table of values for this transmitter, assuming perfect calibration (no error):

Input pressure applied (" Hg)	Percent of span (%)	Output signal (mA)
24		
	19	
		11.7

[file i00473](#)

Question 11

Suppose you wish to calibrate a pneumatic pressure transmitter to an input range of -10 to +50 inches of mercury, with an output range of 3 to 15 PSI. Complete the following calibration table showing the test pressures to use and the allowable low/high output signals for a calibrated tolerance of +/- 0.5% (of span). Assume you can only use positive test pressures (no vacuum), and be sure to designate which side the test pressure should be applied to (H = high ; L = low):

Input pressure applied (" Hg)	Percent of span (%)	Output signal <i>ideal</i> (PSI)	Output signal <i>low</i> (PSI)	Output signal <i>high</i> (PSI)
	0			
	25			
	50			
	75			
	100			

Each correct numerical value is worth 0.8 points (16 total points divided by 20 total answers)

[file i00467](#)

Question 12

A pneumatic differential pressure transmitter has a calibrated range of -100 to $+100$ inches of water column (" W.C.), and its output signal range is 3 to 15 PSI. Complete the following table of values for this transmitter, assuming perfect calibration (no error). Be sure to show your work!

Input pressure applied (" W.C.)	Percent of span (%)	Output signal (PSI)
0		
-30		
		8
		13
	65	
	10	

Suggestions for Socratic discussion

- Develop a linear equation in the form of $y = mx + b$ that directly relates input pressure (x) to output pressure (y).
- Demonstrate how to *estimate* numerical answers for this problem without using a calculator.

[file i00096](#)

Question 13

A turbine flowmeter measuring cooling water for a large power generator uses an electronic circuit to convert its pickup coil pulses into a 4-20 mA analog current signal. The “K factor” for the turbine element is 99 pulses per gallon, and the 4-20 mA analog output is ranged from 0 to 500 GPM flow. Complete the following table of values for this transmitter, assuming perfect calibration (no error). Be sure to show your work!

Measured flow (GPM)	Pickup signal frequency (Hz)	Percent of output span (%)	Output signal (mA)
250			
412			
	305		
	780		
		63	
		49	
			10
			16

Suggestions for Socratic discussion

- Demonstrate how to *estimate* numerical answers for this problem without using a calculator.
- Suppose you were asked to check the accuracy of the frequency-to-current converter circuit for this flowmeter. What sort of test equipment would you use, and how could you perform the test with the flowmeter still installed in the cooling water pipe?
- Could the pulse output of the pickup coil be used directly as a flow signal, or is the converter circuit absolutely necessary?
- Explain how a PLC could be used to *totalize* the water flow through this flowmeter, to provide total usage values at the end of each day.

[file i00101](#)

Question 14

Suppose you wish to calibrate a turbine flowmeter to an input range of 0 to 600 gallons per minute. The *k* factor for this turbine is 20 pulses per gallon, making the input frequency range 0 to 200 Hz for this flow range. The output signal range is 4 to 20 mA. Complete the following calibration table showing the proper test frequencies and the ideal output signals at those levels:

Simulated flow rate (GPM)	Input frequency applied (Hz)	Percent of span (%)	Output signal (mA)
97			
		25	
		60	
400			

[file i02996](#)

Question 15

Suppose you wish to calibrate a turbine flowmeter to an input range of 0 to 300 gallons per minute. The k factor for this turbine is 80 pulses per gallon, making the input frequency range 0 to 400 Hz for this flow range. The output signal range is 4 to 20 mA. Complete the following calibration table showing the proper test frequencies and the ideal output signals at those levels:

Simulated flow rate (GPM)	Input frequency applied (Hz)	Percent of span (%)	Output signal (mA)
		17	
130			
		45	
300			

[file i00694](#)

Question 16

Suppose you wish to calibrate a turbine flowmeter to an input range of 0 to 800 gallons per minute. The k factor for this turbine is 30 pulses per gallon, making the input frequency range 0 to 400 Hz for this flow range. The output signal range is 4 to 20 mA. Complete the following calibration table showing the proper test frequencies and the ideal output signals at those levels:

Simulated flow rate (GPM)	Input frequency applied (Hz)	Percent of span (%)	Output signal (mA)
55			
		25	
		63	
700			

[file i00695](#)

Question 17

An electronic pressure transmitter has a calibrated range of -10 to 60 PSI, and its output signal range is 4 to 20 mA. Complete the following table of values for this transmitter, assuming perfect calibration (no error). Be sure to show your work!

Input pressure applied (PSI)	Percent of span (%)	Output signal (mA)
0		
-5		
		12
		13.6
	40	
	22	

[file i00095](#)

Question 18

A pneumatic level transmitter has a calibrated range of 150 inches to 300 inches of liquid level, with an output range of 3 to 15 PSI. Complete the following table of values for this transmitter, assuming perfect calibration (no error):

Input level applied (inches)	Percent of span (%)	Output signal (PSI)
	4	
		7.2
189		

[file i00506](#)

Question 19

Suppose you wish to calibrate a pneumatic level transmitter to an input range of 0 to 400 inches, with an output range of 3 to 15 PSI. Complete the following calibration table showing the proper test levels and the ideal output signals at those levels:

Input level applied (inches)	Percent of span (%)	Output signal (PSI)
	0	
	25	
	50	
	75	
	100	

[file i00507](#)

Question 20

An ultrasonic level transmitter has a calibrated range of 40 to 75 inches and its output signal range is 4 to 20 mA. Complete the following table of values for this transmitter, assuming perfect calibration (no error). Be sure to show your work!

Measured level (inches)	Percent of span (%)	Output signal (mA)
47		
		6
	75	
60		
		15.1
	34	

Suggestions for Socratic discussion

- Demonstrate how to *estimate* numerical answers for this problem without using a calculator.

[file i00098](#)

Question 21

Suppose you wish to calibrate an RTD temperature transmitter to an input range of 50 to 200 degrees F, with an output range of 4 to 20 mA. Complete the following calibration table showing the proper test temperatures and the ideal output signals at those levels:

Input temp applied (deg F)	Percent of span (%)	Output signal (mA)
	0	
	25	
	50	
	75	
	100	

file i00644

Question 22

Suppose you wish to calibrate a thermocouple temperature transmitter to an input range of 0 to 1500 degrees F, with an output range of 4 to 20 mA. Complete the following calibration table showing the proper test temperatures and the ideal output signals at those levels:

Input temp applied (deg F)	Percent of span (%)	Output signal (mA)
	0	
	25	
	50	
	75	
	100	

file i00645

Question 23

A temperature transmitter has a calibrated range of -80 to 150 degrees F and its output signal range is 4 to 20 mA. Complete the following table of values for this transmitter, assuming perfect calibration (no error). Be sure to show your work!

Measured temp (°F)	Percent of span (%)	Output signal (mA)
120		
-45		
	42	
	25	
		7.5
		12.9

file i00099

Question 24

A Foxboro pneumatic square root extractor has a calibrated range of 3 to 15 PSI for both input and output. Complete the following table of values for this relay, assuming perfect calibration (no error). Be sure to show your work!

Input signal (PSI)	Percent of input span (%)	Percent of output span (%)	Output signal (PSI)
5			
13			
	50		
	30		
		80	
		15	
			7
			12

Suggestions for Socratic discussion

- Why are pneumatic square-root extractors all but obsolete in modern industry? What has replaced their functionality?
- Share problem-solving techniques for obtaining answers to this problem.

file i00100

Question 25

Every instrument has at least one input and at least one output. For instruments responding linearly, the correspondence between input and output is proportional:

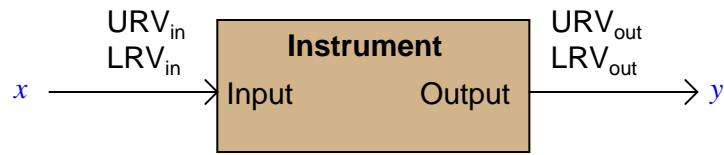

$$\frac{x - LRV_{in}}{URV_{in} - LRV_{in}} = \frac{y - LRV_{out}}{URV_{out} - LRV_{out}}$$

A practical example of this is a pressure transmitter, in this case one with an input range of 0 to 1023 PSI and an output of 4-20 mA:

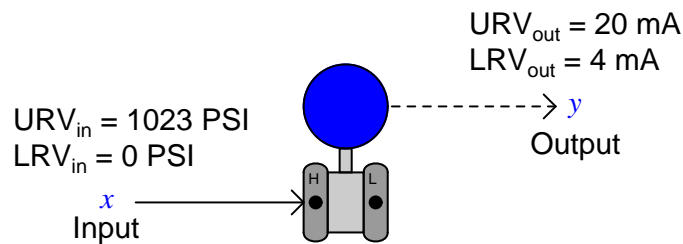

$$\frac{x - 0 \text{ PSI}}{1023 \text{ PSI}} = \frac{y - 4 \text{ mA}}{16 \text{ mA}}$$

If you happened to measure an output current of 14.7 mA from this pressure transmitter, it would be a simple matter for you to calculate the corresponding input pressure to be 684.13 PSI.

However, students are often taken by surprise when they encounter an analog-to-digital converter (ADC) or digital-to-analog converter (DAC) and are asked to correlate input and output for such devices. What might seem a daunting task at first, though, soon reveals itself to be the same input-to-output correspondence calculations they've seen all along in the guise of analog sensors and other instruments.

Take for example this analog-to-digital converter, with a 10-bit output (a "count" range of 0 to 1023) and a 4-20 mA input:

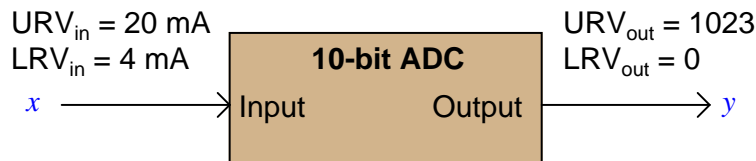

Calculate the corresponding "count" output of this ADC circuit given a 6.82 mA input signal.

Suggestions for Socratic discussion

- Explain why the “count” value generated by an analog-to-digital converter must be an integer number. For example, explain why a count value of 3275 might be valid, but a count value of 3274.83 is not.

[file i04545](#)

Question 26

The ADC0804 is an example of an integrated circuit analog-to-digital converter (ADC), converting an analog input voltage signal into an 8-bit binary output:

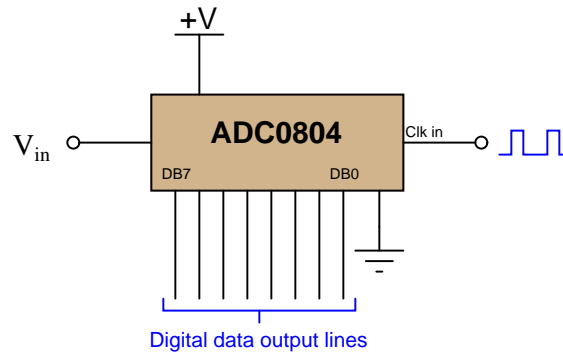

When operated from a 5.0 volt DC power supply in its simplest mode, the ADC0804 converts any DC input voltage between 0.0 volts and 5.0 volts into an 8-bit number at the command of a clock pulse. A 0.0 volt input yields a binary output (or “count”) of 00000000, of course, while a 5.0 volt input yields a count of 11111111.

Complete this table of numbers, relating various DC input voltages with count values (expressed in binary, hex, and decimal) for an ADC0804 having an input range of 0.0 to 5.0 volts DC:

DC input voltage	Binary count	Hex count	Decimal count
0.0 volts	00000000		
	00110011		51
2.2 volts		70	
		B3	179
	11001100	CC	
5.0 volts	11111111		

Suggestions for Socratic discussion

- Explain why the “count” value generated by an analog-to-digital converter must be an integer number. For example, explain why a count value of 3275 might be valid, but a count value of 3274.83 is not.

[file i03270](#)

Question 27

An analog-to-digital converter has a 12-bit binary output and an analog input voltage range of 0.0 to + 5.0 volts. Calculate:

- The digital output (in hexadecimal) at 0.0 volts analog input = _____
- The digital output (in hexadecimal) at 5.0 volts analog input = _____
- The digital output (in hexadecimal) at 2.1 volts analog input = _____
- The analog input corresponding to a digital output of 2D0 = _____ volts
- The analog input corresponding to a digital output of F14 = _____ volts

[file i03587](#)

Question 28

An analog-to-digital converter has a 16-bit binary output and an analog input voltage range of 0.0 to + 10.0 volts. Calculate:

- The digital output (in hexadecimal) at 0.0 volts analog input = _____
- The digital output (in hexadecimal) at 10.0 volts analog input = _____
- The digital output (in hexadecimal) at 3.4 volts analog input = _____
- The analog input corresponding to a digital output of 3D6A = _____ volts
- The analog input corresponding to a digital output of C005 = _____ volts

[file i02661](#)

Question 29

An analog-to-digital converter (ADC) has a calibrated input range of 0 to 10 volts, and a 12-bit output (0 to 4095 “count” range). Complete the following table of values for this converter, assuming perfect calibration (no error):

Input voltage (volts)	Percent of span (%)	Counts (decimal)	Counts (hexadecimal)
	0		
	25		
	50		
	75		
	100		

[file i03823](#)

Question 30

An essential component of any digital control system is an *analog-to-digital converter*, or *ADC*. This is necessary to convert the analog process variable measurement into a digital number for the control algorithm to process. Another essential component is a *digital-to-analog converter*, or *DAC*, which does the exact opposite.

In a system using 4-20 mA analog currents to relay instrument signals, there is an ADC located at the process variable input of the controller, and a DAC located at the output of the controller:

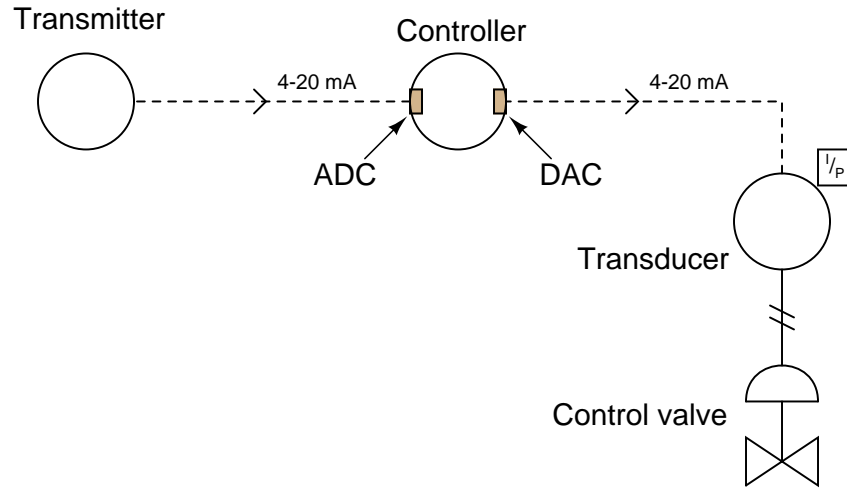

In digital "Fieldbus" systems, the communication is all digital, which places the ADC at the transmitter and the DAC at the transducer:

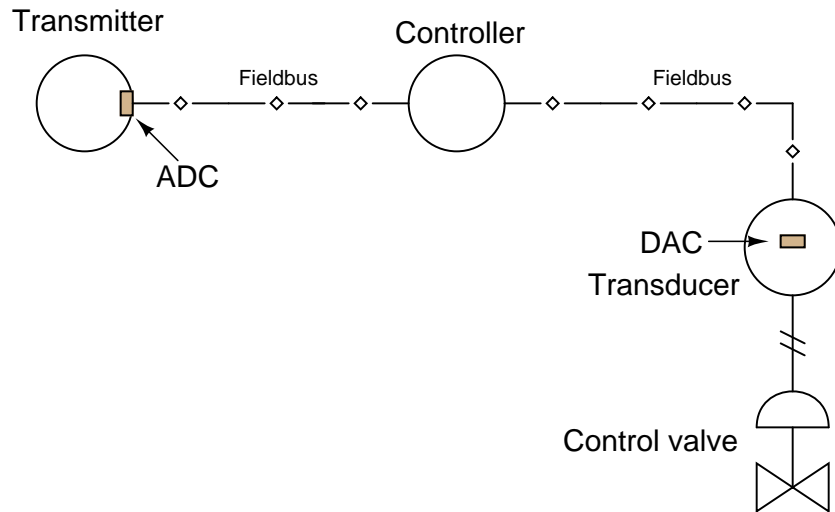

In either case, we need to “scale” the binary count of the ADC and DAC to their respective analog variable values. Consider a flow control system, with a flow transmitter ranged from 0 to 200 GPM and a pneumatic control valve operating on a pressure range of 3 to 15 PSI (instrument air). Assuming the ADC has a resolution of 16 bits (a digital conversion range of \$0000 to \$FFFF) and the DAC has a resolution of 14 bits (a digital conversion range of \$0000 to \$3FFF), determine the digital values corresponding to a 50% PV signal (100 GPM flow rate) and a 50% valve position (9 PSI pneumatic signal). Write these hexadecimal number values in the following tables:

Calibration table for process variable signal (ADC)

Measurement	Digital output
0 GPM	\$0000
100 GPM	
200 GPM	\$FFFF

Calibration table for output signal (DAC)

Measurement	Digital output
\$0000	0 PSI
	9 PSI
\$3FFF	15 PSI

Note that the DAC output does *not* correspond to a live zero scale. In other words, a digital input value of \$0000 will output no pressure to the valve (0 PSI), rather than a standard pneumatic “zero” signal of 3 PSI.

[file i01498](#)

Question 31

An analog-to-digital converter (ADC) has a calibrated input range of 0 to 10 volts, and a 16-bit output (0 to 65535 “count” range). Complete the following table of values for this converter, assuming perfect calibration (no error):

Input voltage (volts)	Percent of span (%)	Counts (decimal)	Counts (hexadecimal)
	0		
	25		
	50		
	75		
	100		

[file i03824](#)

Question 32

A digital pressure transmitter has a calibrated input range of 0 to 75 PSI, and a 14-bit output (0 to 16383 “count” range). Complete the following table of values for this transmitter, assuming perfect calibration (no error):

Input pressure (PSI)	Percent of span (%)	Counts (decimal)	Counts (hexadecimal)
	0		
	36		
	62		
	89		
	95		

file i03825

Question 33

A digital pressure transmitter has a calibrated input range of 50 to 200 PSI, and a 10-bit output (0 to 1023 “count” range). Complete the following table of values for this transmitter, assuming perfect calibration (no error):

Input pressure (PSI)	Percent of span (%)	Counts (decimal)	Counts (hexadecimal)
	7		
	22		
	39		
	56		
	78		

file i03826

Question 34

A digital level transmitter has a calibrated input range of 20 to 170 inches of liquid level, and a 10-bit output (0 to 1023 “count” range). Complete the following table of values for this transmitter, assuming perfect calibration (no error):

Input level (inches)	Percent of span (%)	Counts (decimal)	Counts (hexadecimal)
	11		
	28		
	55		
	73		
	92		

[file i03827](#)

Question 35

An analog-to-digital converter (ADC) has a calibrated input range of 0 to 5 volts, and a 12-bit output. Complete the following table of values for this converter, assuming perfect calibration (no error):

Input voltage (volts)	Percent of span (%)	Counts (decimal)	Counts (hexadecimal)
1.6			
		3022	
	40		
			A2F

Suggestions for Socratic discussion

- Calculate the resolution of this ADC in *percent* of full-scale range. In other words, what is the smallest percentage of input signal change it is able to resolve?

[file i03822](#)

Question 36

Suppose a FOUNDATION Fieldbus pressure transmitter is connected to measure the pressure of natural gas inside a pipeline. The expected range of pressure inside this vessel is 0 to 600 PSI.

Determine the proper configuration parameters for this Fieldbus instrument’s Analog Input (AI) block:

L_Type	
XD_Scale	
OUT_Scale	

[file i01218](#)

Question 37

Suppose a FOUNDATION Fieldbus differential pressure transmitter is connected to measure the pressure drop created by an orifice plate, proportional to the square of fluid flow rate through the orifice. At a flow rate of 400 GPM, the orifice produces a pressure differential of 135 inches water column.

Determine the proper configuration parameters for this Fieldbus instrument's Analog Input (AI) block:

L_Type	
XD_Scale	
OUT_Scale	

[file i01216](#)

Question 38

Suppose a FOUNDATION Fieldbus pressure transmitter is connected to the hydraulic line supplying fluid pressure to a ram, for the purpose of measuring the ram's exerted force based on sensed pressure. Recall that the relationship between force and fluid pressure for a piston is $F = PA$, where F is force in pounds, A is surface area of the piston in square inches, and P is fluid pressure in PSI. Recall as well that the area for a circular object is given by the formula $A = \pi r^2$.

Supposing the ram's piston has a diameter of exactly 2 inches, determine the proper configuration parameters for this Fieldbus instrument's Analog Input (AI) block, assuming we wish this transmitter to report ram force over a range of 0 to 4700 pounds.

L_Type	
XD_Scale	
OUT_Scale	

[file i01222](#)

Question 39

Suppose a FOUNDATION Fieldbus pressure transmitter is connected to the bottom of a vessel containing a liquid half as dense as water, for the purpose of measuring liquid height inside the vessel based on hydrostatic pressure. For every foot of liquid height, 6 inches water column pressure is sensed by the transmitter.

Determine the proper configuration parameters for this Fieldbus instrument's Analog Input (AI) block, assuming we wish this transmitter to report liquid height over a range of 0 to 18 feet:

L_Type	
XD_Scale	
OUT_Scale	

[file i01217](#)

Question 40

Suppose a FOUNDATION Fieldbus pressure transmitter is connected to the bottom of a water storage tank, for the purpose of measuring water volume stored inside the tank based on hydrostatic pressure. The tank is shaped like a vertical cylinder, 10 feet in diameter and 20 feet high.

Determine the proper configuration parameters for this Fieldbus instrument's Analog Input (AI) block, assuming we wish this transmitter to report liquid height over a range of 0 to 15 feet, expressed in units of cubic feet:

L_Type	
XD_Scale	
OUT_Scale	

[file i01220](#)

Question 41

Suppose a FOUNDATION Fieldbus pressure transmitter is connected to the bottom of a liquid storage vessel for the purpose of measuring liquid height based on hydrostatic pressure. This transmitter happens to be configured with the following Analog Input (AI) block parameters:

L_Type	Indirect
XD_Scale	38 to 183.488 inches WC
OUT_Scale	0 to 14 feet

Calculate the height reported by this transmitter when it senses a hydrostatic pressure of 71.8 inches WC.

Calculate the hydrostatic pressure sensed by this transmitter when it reports a liquid height of 9.3 feet.

[file i01221](#)

Answers

Answer 1

Here are two possible formulae for entry into cell R2C5:

$$= ((R2C1 - 4) / 16) * 12 + 3$$

$$= R2C3 * 12 + 3$$

One very practical use for this type of spreadsheet program is to create practice problems for yourself, so that you may practice instrument input/output range calculations.

Answer 2

Shaft speed (RPM)	Output voltage (volts DC)
100	0.67
350	2.3
500	3.3
750	5.0
890	5.9
975	6.5
1230	8.2
1410	9.4
1500	10.00

Answer 3

Input pressure applied (PSI)	Percent of span (%)	Output signal (mA)
0	0	4
12.5	25	8
25	50	12
37.5	75	16
50	100	20

Answer 4

Input pressure applied (PSI)	Percent of span (%)	Output signal (mA)
0	0	4
50	25	8
100	50	12
150	75	16
200	100	20

Answer 5

Input current (mA)	Percent of range (%)	Output pressure (PSI)
4	0	3
5.6	10	4.2
7.2	20	5.4
8	25	6
8.8	30	6.6
10.4	40	7.8
12	50	9
13.6	60	10.2
15.2	70	11.4
16	75	12
16.8	80	12.6
18.4	90	13.8
20	100	15

Follow-up question: explain the procedure for starting with a current value in milliamps and calculating the equivalent percentage.

Answer 6

Input signal applied (mA)	Percent of span (%)	Output pressure (PSI)
9.6	35	7.2
16.8	80	12.6
19.2	95	14.4

Answer 7

Measured level (feet)	Percent of span (%)	Output signal (mA)
1.6	80	16.8
0.3875	19.375	7.1
0.8	40	10.4

Answer 8

Measured level (feet)	Percent of span (%)	Output signal (PSI)
3.2	64	10.68
0.4167	8.333	4
2.5	50	9
2.4	48	8.76
3.458	69.17	11.3
0.9	18	5.16

Answer 9

Input pressure applied (" W.C.)	Percent of span (%)	Output signal (mA)
2.5	5	4.8
16.5	33	9.28
30.5	61	13.76

Answer 10

Input pressure applied (" Hg)	Percent of span (%)	Output signal (mA)
24	12	5.92
38	19	7.04
96.25	48.13	11.7

Answer 11

Input pressure applied (" Hg)	Percent of span (%)	Output signal <i>ideal</i> (mA)	Output signal <i>low</i> (mA)	Output signal <i>high</i> (mA)
10 L	0	3	2.94	3.06
5 H	25	6	5.94	6.06
20 H	50	9	8.94	9.06
35 H	75	12	11.94	12.06
50 H	100	15	14.94	15.06

Answer 12

Input pressure applied (" W.C.)	Percent of span (%)	Output signal (PSI)
0	50	9
-30	35	7.2
-16.67	41.67	8
66.67	83.33	13
30	65	10.8
-80	10	4.2

Answer 13

Measured flow (GPM)	Pickup signal frequency (Hz)	Percent of output span (%)	Output signal (mA)
250	412.5	50	12
412	679.8	82.4	17.18
184.8	305	36.97	9.915
472.7	780	94.55	19.13
315	519.8	63	14.08
245	404.3	49	11.84
187.5	309.4	37.5	10
375	618.8	75	16

$$f = kQ$$

Where,

f = Frequency in Hertz (pulses per second)

k = Calibration factor in pulses per gallon

Q = Volumetric flow rate in gallons per second

$$f = \frac{kQ}{60}$$

Where,

f = Frequency in Hertz (pulses per second)

k = Calibration factor in pulses per gallon

Q = Volumetric flow rate in gallons per minute

Answer 14

Simulated flow rate (GPM)	Input frequency applied (Hz)	Percent of span (%)	Output signal (mA)
97	32.33	16.17	6.587
150	50	25	8
360	120	60	13.6
400	133.3	66.6	14.67

Answer 15

Simulated flow rate (GPM)	Input frequency applied (Hz)	Percent of span (%)	Output signal (mA)
51	68	17	6.72
130	173.33	43.33	10.933
135	180	45	11.2
300	400	100	20

Answer 16

Simulated flow rate (GPM)	Input frequency applied (Hz)	Percent of span (%)	Output signal (mA)
55	27.5	6.875	5.1
200	100	25	8
504	252	63	14.08
700	350	87.5	18

Answer 17

Partial answer:

Input pressure applied (PSI)	Percent of span (%)	Output signal (mA)
0	14.29	6.286
-5		
		12
32	60	13.6
	40	
	22	

Answer 18

Input level applied (inches)	Percent of span (%)	Output signal (PSI)
156	4	3.48
202.5	35	7.2
189	26	6.12

Answer 19

Input level applied (inches)	Percent of span (%)	Output signal (PSI)
0	0	3
100	25	6
200	50	9
300	75	12
400	100	15

Answer 20

Measured level (inches)	Percent of span (%)	Output signal (mA)
47	20	7.2
44.38	12.5	6
66.25	75	16
60	57.14	13.14
64.28	69.38	15.1
51.9	34	9.44

Answer 21

Input temp applied (deg F)	Percent of span (%)	Output signal (mA)
50	0	4
87.5	25	8
125	50	12
162.5	75	16
200	100	20

Answer 22

Input temp applied (deg F)	Percent of span (%)	Output signal (mA)
0	0	4
375	25	8
750	50	12
1125	75	16
1500	100	20

Answer 23

Measured temp (°F)	Percent of span (%)	Output signal (mA)
120	86.96	17.91
-45	15.22	6.435
16.6	42	10.72
-22.5	25	8
-29.69	21.88	7.5
47.94	55.63	12.9

Answer 24

Partial answer:

Input signal (PSI)	Percent of input span (%)	Percent of output span (%)	Output signal (PSI)
5			
13	83.33	91.29	13.95
	50		
	30		
		80	
3.27	2.25	15	4.8
			7
			12

Answer 25

Count = 180 (rounding low) or 181 (rounding high)

Answer 26

Partial answer:

DC input voltage	Binary count	Hex count	Decimal count
0.0 volts	00000000		
1.0 volts	00110011		51
2.2 volts	01110000	70	112
3.51 volts	10110011	B3	179
4.0 volts	11001100	CC	204
5.0 volts	11111111	FF	

Answer 27

- The digital output (in hexadecimal) at 0.0 volts analog input = **000**
- The digital output (in hexadecimal) at 5.0 volts analog input = **FFF**
- The digital output (in hexadecimal) at 2.1 volts analog input = **6B7** or **6B8**
- The analog input corresponding to a digital output of 2D0 = **0.8791** volts
- The analog input corresponding to a digital output of F14 = **4.713** volts

Answer 28

- The digital output (in hexadecimal) at 0.0 volts analog input = **0000**
- The digital output (in hexadecimal) at 10.0 volts analog input = **FFFF**
- The digital output (in hexadecimal) at 3.4 volts analog input = **5709** or **570A**
- The analog input corresponding to a digital output of 3D6A = **2.399** volts
- The analog input corresponding to a digital output of C005 = **7.501** volts

Answer 29

Input voltage (volts)	Percent of span (%)	Counts (decimal)	Counts (hexadecimal)
0	0	0	000
2.5	25	1023 or 1024	3FF or 400
5.0	50	2047 or 2048	7FF or 800
7.5	75	3071 or 3072	BFF or C00
10	100	4095	FFF

Answer 30

Calibration table for process variable signal (ADC)

Measurement	Digital output
0 GPM	\$0000
100 GPM	\$8000
200 GPM	\$FFFF

Calibration table for output signal (DAC)

Measurement	Digital output
\$0000	0 PSI
\$2666	9 PSI
\$3FFF	15 PSI

Answer 31

Input voltage (volts)	Percent of span (%)	Counts (decimal)	Counts (hexadecimal)
0	0	0	0000
2.5	25	16383 or 16384	3FFF or 4000
5.0	50	32767 or 32768	7FFF or 8000
7.5	75	49151 or 49152	BFFF or C000
10	100	65535	FFFF

Answer 32

Input pressure (PSI)	Percent of span (%)	Counts (decimal)	Counts (hexadecimal)
0	0	0	000
27	36	5897 or 5898	1709 or 170A
46.5	62	10157 or 10158	27AD or 27AE
66.75	89	14580 or 14581	38F4 or 38F5
71.25	95	15563 or 15564	3CCB or 3CCC

Answer 33

This is a graded question – no answers or hints given!

Answer 34

Input level (inches)	Percent of span (%)	Counts (decimal)	Counts (hexadecimal)
36.5	11	112 or 113	070 or 071
62.0	28	286 or 287	11E or 11F
102.5	55	562 or 563	232 or 233
129.5	73	746 or 747	2EA or 2EB
158.0	92	941 or 942	3AD or 3AE

Answer 35

Partial answer:

Input voltage (volts)	Percent of span (%)	Counts (decimal)	Counts (hexadecimal)
1.6	32	1310 or 1311	
	73.8	3022	
	40		666
3.18			A2F

Answer 36

L_Type	Direct
XD_Scale	0 to 600 PSI
OUT_Scale	0 to 600 PSI

Note that the **OUT_Scale** parameter is redundant in this application. So long as **L_Type** is set to “Direct” the transmitter will report whatever its transducer senses, regardless of the **OUT_Scale** parameters.

Answer 37

L_Type	Indirect Square Root
XD_Scale	0 to 135 inches WC
OUT_Scale	0 to 400 GPM

Answer 38

L_Type	Indirect
XD_Scale	0 to 1496.1 PSI
OUT_Scale	0 to 4700 pounds

Answer 39

L_Type	Indirect
XD_Scale	0 to 108 inches WC
OUT_Scale	0 to 18 feet

Answer 40

L.Type	Indirect
XD_Scale	0 to 180 inches WC
OUT_Scale	0 to 1178.1 cubic feet

Answer 41

Calculate the height reported by this transmitter when it senses a hydrostatic pressure of 71.8 inches WC. **Height = 3.2525 feet**

Calculate the hydrostatic pressure sensed by this transmitter when it reports a liquid height of 9.3 feet. **Pressure = 134.65 inches WC**