

## Static fluids

This worksheet and all related files are licensed under the Creative Commons Attribution License, version 1.0. To view a copy of this license, visit <http://creativecommons.org/licenses/by/1.0/>, or send a letter to Creative Commons, 559 Nathan Abbott Way, Stanford, California 94305, USA. The terms and conditions of this license allow for free copying, distribution, and/or modification of all licensed works by the general public.

This worksheet introduces the basic concepts of gases and liquids.

## Questions

### Question 1

Suppose we were to steadily pour a liquid into the leftmost vertical tube until it reaches a mark four inches from the bottom. Given the diameters of the other tubes, how high will the liquid level settle in each when all columns are in a condition of equilibrium (no liquid *flowing* through any part of the system)?

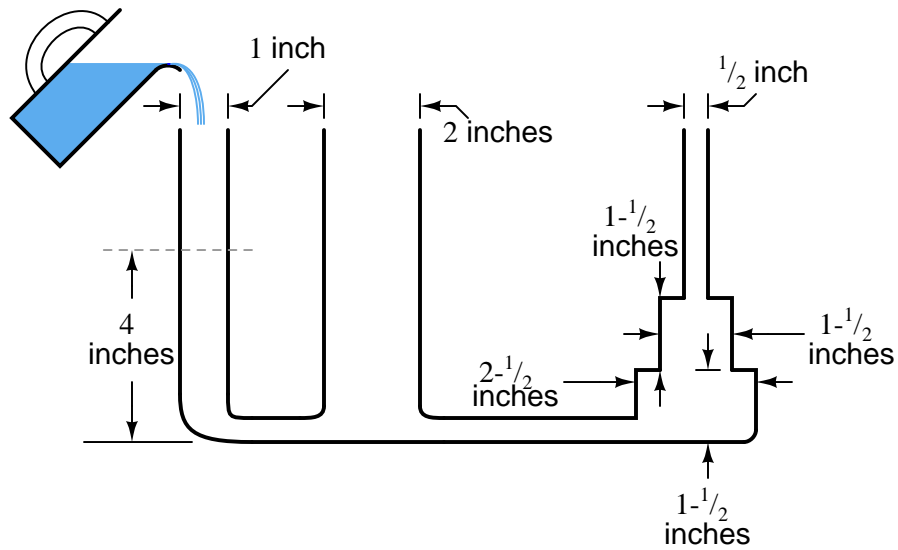

Now consider the same set of vertical tubes (same diameters, same step heights) connected at the bottom by an *inclined* pipe. If we were to pour a liquid into the leftmost vertical tube until it reaches a mark two inches from its bottom, how high will the liquid level settle in each column when all columns are in a condition of equilibrium?

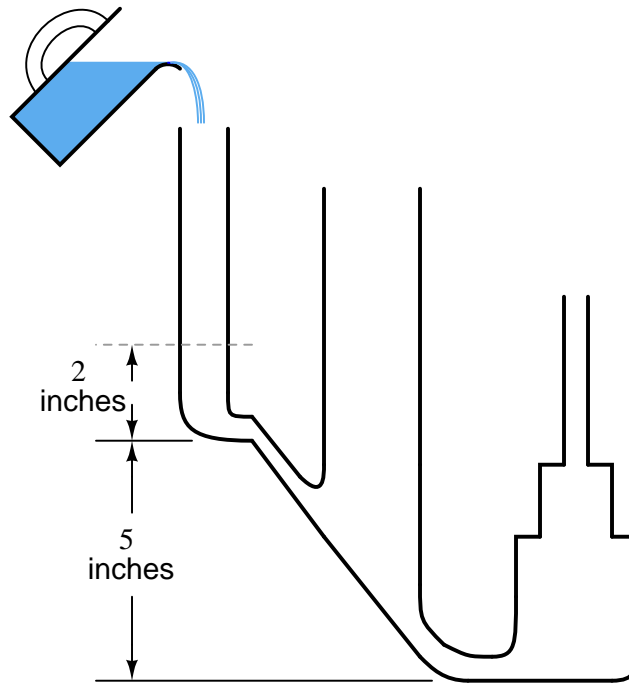

file i00236

---

Question 2

Which of these tubes will generate the most hydrostatic pressure, assuming they all contain the same type of liquid at precisely the same (vertical) height?

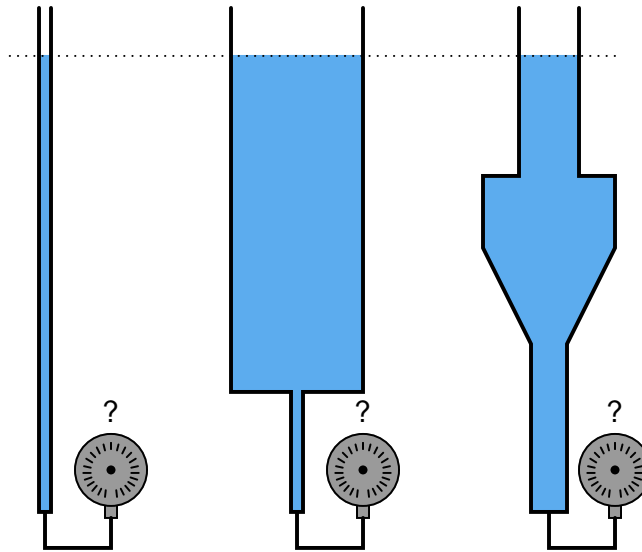

[file i02953](#)

---

Question 3

Toluene has a density of  $0.8669 \text{ g/cm}^3$  at  $20^\circ \text{ C}$ . Calculate its density in units of pounds per cubic feet and its specific gravity (unitless).

[file i00233](#)

---

Question 4

A liquid has a density of 865 kilograms per cubic meter. Calculate its specific gravity.

A liquid has a density of 59 pounds per cubic foot. Calculate its specific gravity.

[file i00237](#)

---

Question 5

If force is exerted on the piston of this hydraulic cylinder, in what direction(s) will this force be transmitted to the cylinder walls? In other words, how does a fluid under pressure push against its surrounding container?

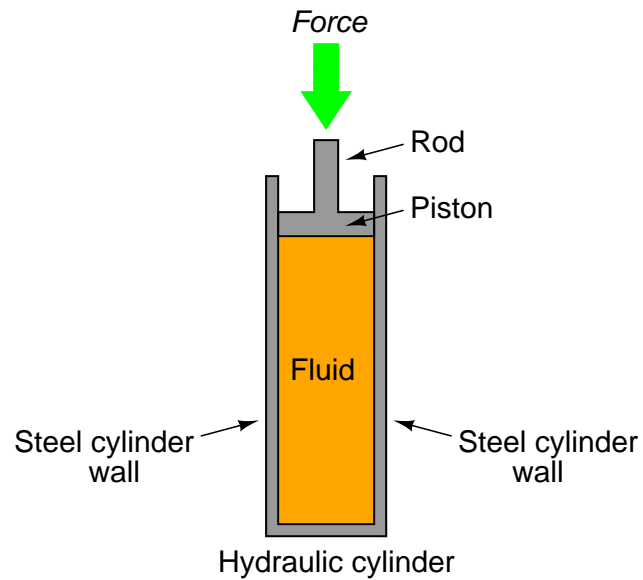

[file i00142](#)

---

Question 6

Suppose a small rubber ball is floating inside the fluid of a hydraulic cylinder as shown below. What will happen to the ball when a pushing force is exerted on the cylinder's rod? What will happen to the ball when a pulling force is exerted on the rod?

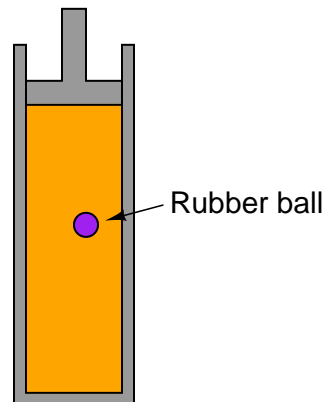

[file i00143](#)

### Question 7

A surface-mounted water pump pulls water out of a well by creating a vacuum, though it might be more technically accurate to say that the pump works by reducing pressure in the inlet pipe to a level less than atmospheric pressure, allowing atmospheric pressure to then push water from the well up the pump's inlet pipe:

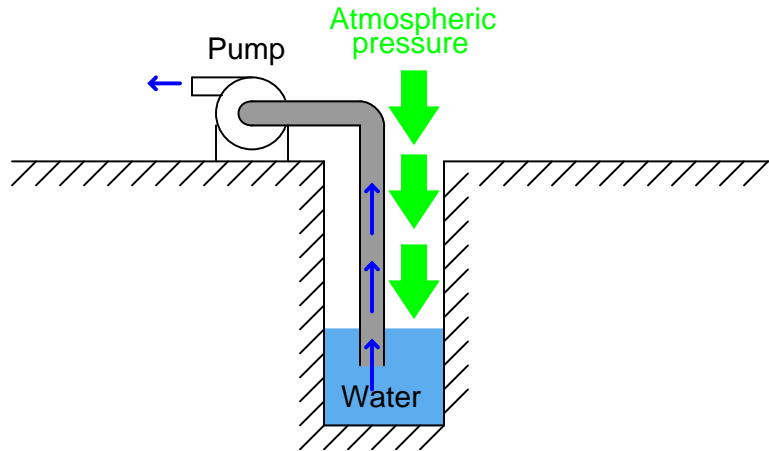

Based on this description of pump operation, what is the theoretical maximum height that any pump can lift water out of a well, assuming the well is located at sea level?

Water wells located at altitudes other than sea level will have different theoretical maximum lifting heights (i.e. the farthest distance a surface-mounted pump may suck water out of the well). Research the average barometric pressure in Denver, Colorado (the “mile-high” city) and determine how far up a surface pump may draw water from a well in Denver.

Domestic water wells may be hundreds of feet deep. How can water be pumped out of wells this deep, given the height limitation of vacuum pumping?

#### Suggestions for Socratic discussion

- If the liquid in question was something other than water, would the maximum “lift” depth be different? Why or why not?

[file i00147](#)

Question 8

Water pressure available at a fire hydrant is 80 PSI. If a fire hose is connected to the hydrant and the hydrant valve opened, how high can the end of the hose be raised and still have water flow out the end?

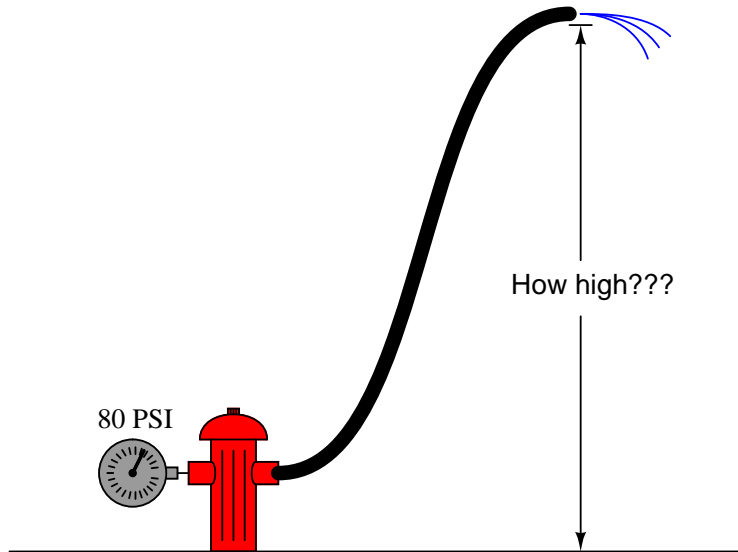

Now, suppose that a spray nozzle attached to the end of the hose requires at least 30 PSI of pressure at the coupling in order to create a proper spray of water. How high can the hose be raised then, and still have enough water pressure at the nozzle to allow for the fighting of a fire?

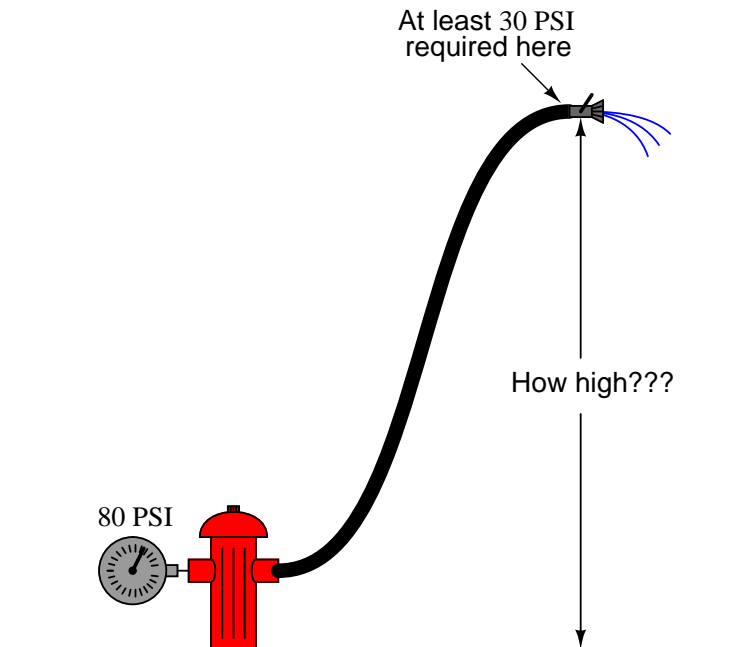

**Suggestions for Socratic discussion**

- How may firefighters ensure they are able to spray water high enough to put out tall building fires, if the hydrant pressure is insufficient?

- Describe a scenario with this fire hose that would illustrate *Pascal's Principle*.

[file i00148](#)

Question 9

Explain how a vertical height of liquid is able to create pressure, such as in this example:

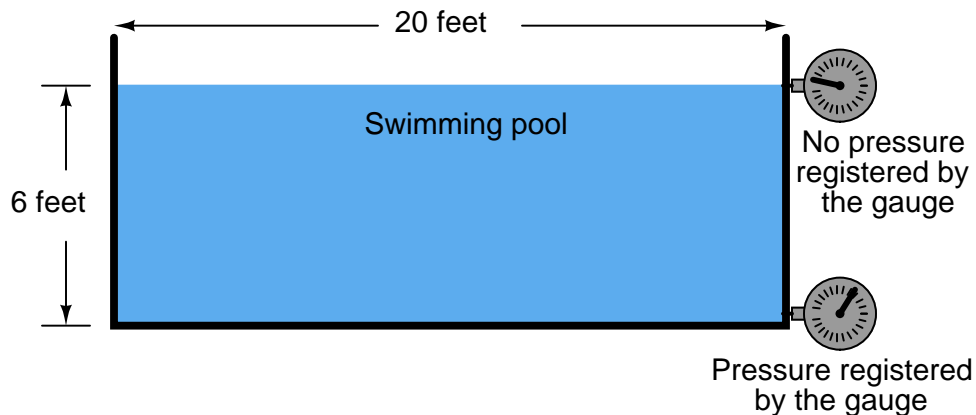

The deeper you descend into the water, the more pressure there is.

Recall that pressure is defined as force divided by area:

$$P = \frac{F}{A}$$

Calculate the total weight of the water contained in this swimming pool (assuming the pool is circular in shape, the 20-foot dimension being its *diameter*), and use this figure to calculate pressure at the bottom of the pool, knowing that pressure is defined as force exerted over an area. Remember that the density of water is 62.428 lb/ft<sup>3</sup>.

Weight of water = \_\_\_\_\_ lbs

Pressure at bottom of pool = \_\_\_\_\_ PSI

[file i00749](#)

---

Question 10

*Specific gravity* is defined as the ratio of densities between a particular fluid and a reference fluid. For liquids, the reference fluid is water; for gases, the reference fluid is air.

For example, the density of olive oil is  $57.3 \text{ lb/ft}^3$  and the density of water is  $62.4 \text{ lb/ft}^3$ . Calculating the ratio of these two densities yields the specific gravity of olive oil: 0.918. That is to say, the density of olive oil is 91.8% that of water.

A useful definition of specific gravity when performing hydrostatic pressure calculations for various liquids is the ratio of equivalent water column height to the height of a particular liquid. Using the specific gravity of olive oil (0.918) as an example, we could say that 0.918 units of water column height will generate the same hydrostatic pressure as 1 unit of olive oil height. The unit could be “inches,” “centimeters,” “millimeters,” “cubits,” or anything else:

$$0.918 \text{ unit W.C. pressure} = 1 \text{ unit olive oil pressure}$$

We may make a “unity fraction” from this equality, since we are dealing with two physically equal quantities: the amount of hydrostatic pressure generated by two vertical columns of different liquids.

$$\frac{0.918 \text{ unit W.C.}}{1 \text{ unit olive oil}} = \text{unity}$$

Apply this “unity fraction” to the calculation of hydrostatic pressure at the bottom of a 20 foot tall storage tank filled to the top with olive oil, expressing that pressure in units of kPa. Show how the units cancel in your calculation(s), beginning with feet of olive oil and ending in kilo-Pascals (kPa):

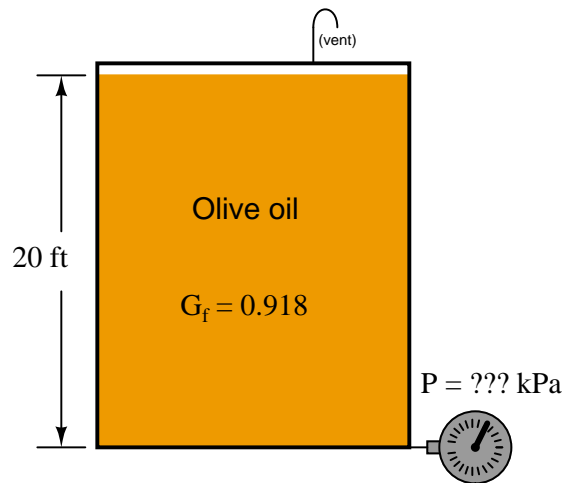

file i02956



---

Question 11

A vessel contains three different liquids of different specific gravities: glycerine, water, and olive oil. These three liquids settle at different levels in the vessel, so that there is a 3 foot deep layer of glycerine, a 2 foot deep layer of water, and a 4.5 foot deep layer of olive oil:

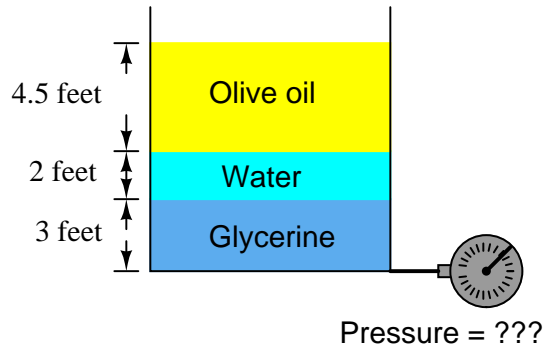

Calculate the total hydrostatic pressure at the bottom of the vessel, in units of PSI and kPa.  
[file i00235](#)

---

Question 12

A device called a *manometer* is a very simple and yet very precise pressure measuring instrument. It works on the principle of a differential pressure displacing a vertical liquid column. The distance between the tops of the two liquid columns is proportional to the difference in pressure applied to tops of the two vertical tubes. This is where we get pressure units of “inches/centimeters of water column” and “inches/centimeters/millimeters of mercury” – from the operation of a manometer:

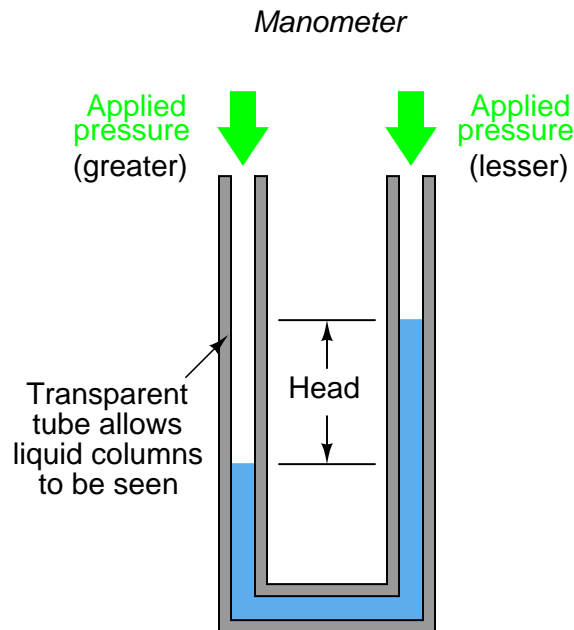

Explain how this instrument may serve as a standard for pressure measurement, just as a deadweight tester may serve as a standard for pressure generation. To phrase this question in the negative, what would have to change in order to affect the pressure measurement accuracy of a manometer?

[file i00160](#)

---

Question 13

How much pressure is being applied to this U-tube water manometer, in units of “inches of water column” and “pounds per square inch”?

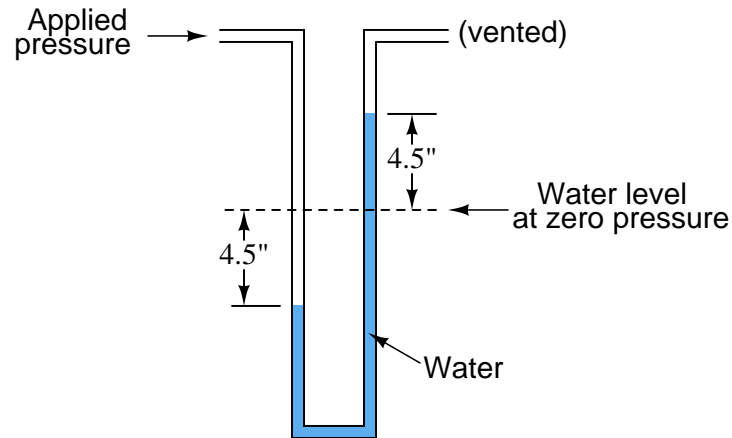

What would happen to the liquid levels if the water were replaced by an oil with a lesser *density*? Given the same applied pressure, would the distance between the two liquid columns be greater, less, or the same as shown in the above illustration?

[file i00161](#)

---

Question 14

How much pressure, in units of “inches of water column,” is being applied to the right-hand tube of this U-tube water manometer?

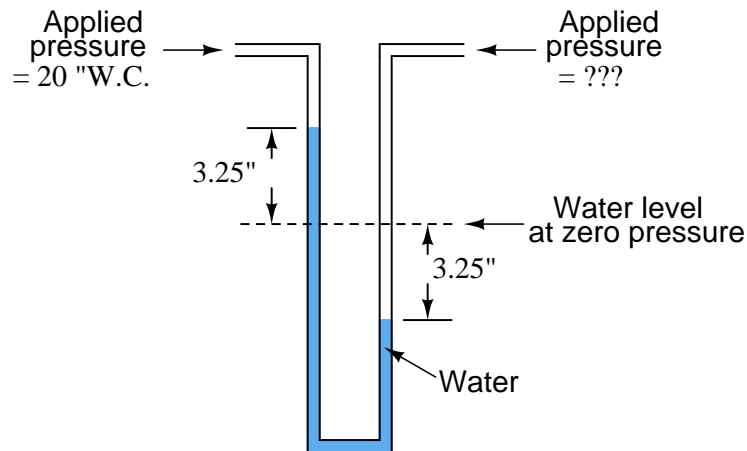

Also, convert this pressure into units of Pascals.

**Suggestions for Socratic discussion**

- How much *differential pressure* is registered by this manometer?

[file i00163](#)

Question 15

How much pressure is being applied to this U-tube water manometer, in units of “inches of water column” and “pounds per square inch”?

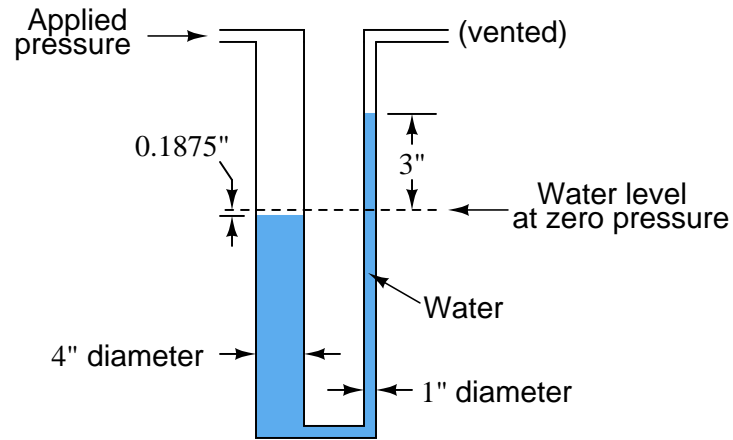

file i00162

Question 16

Calculate the height of glycerine ( $\gamma = 78.6 \text{ lb/ft}^3$ ) in a vertical tube if there is 21 PSI of hydrostatic pressure at the bottom of the tube:

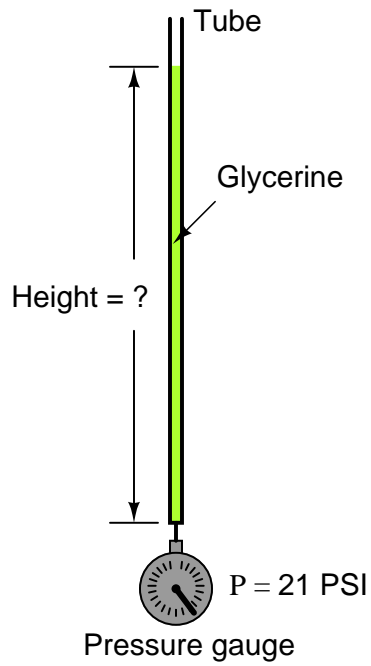

Glycerine height = \_\_\_\_\_ ft

Also, calculate the height of castor oil ( $\gamma = 60.5 \text{ lb/ft}^3$ ) necessary to generate the exact same amount of pressure:

Castor oil height = \_\_\_\_\_ ft

[file i02951](#)

---

Question 17

The following illustration shows a rather strange manometer, one with two different liquids inside, coupled by a hand valve:

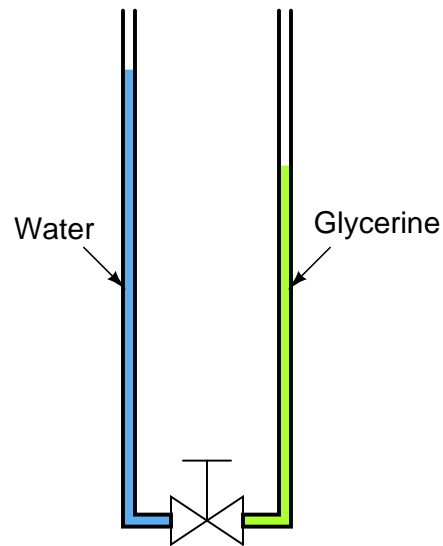

If the two columns of liquid are just right, they will remain at their respective (different) heights when the valve is opened. Unlike a normal manometer where the two liquid columns always equalize to the same height when vented, this manometer is “content” to rest at different heights. Explain why.

Also, calculate two possible heights that will balance each other, given the liquids of water and glycerine.  
[file i02952](#)

---

Question 18

How much pressure, in inches of water column, is being applied to this *inclined* water manometer to displace water 5 inches along the length of the tube, inclined at an angle of  $30^\circ$  from horizontal? Assume a negligible change in liquid level inside the “well” throughout the measurement range of the instrument:

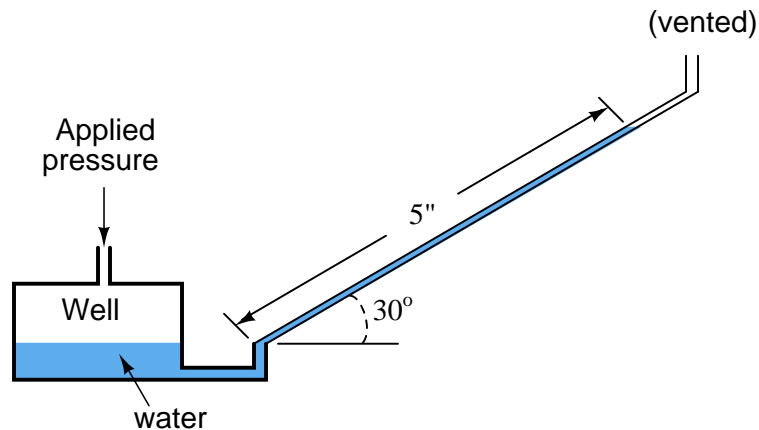

[file i00167](#)

---

Question 19

A tube containing a 10 foot long column of water is angled  $40^\circ$  from horizontal. Calculate the hydrostatic pressure at the bottom of this tube in units of inches water column ("W.C.) and also in units of atmospheres.

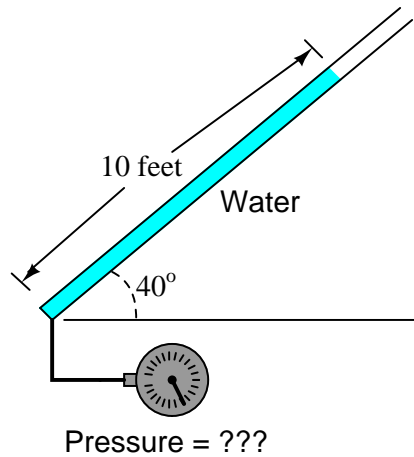

[file i00234](#)

---

Question 20

A simple way to make a *micromanometer* (an extremely sensitive manometer) is to connect two large-diameter vertical tubes by a small-diameter, transparent tube with an air bubble in it. The air bubble becomes the marker for reading pressure along a scale:

*A simple micromanometer*

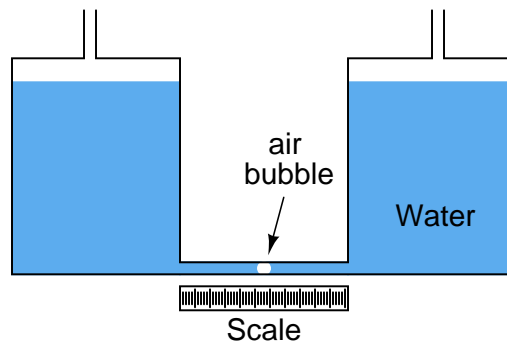

If both of the large vertical tubes are 2.5 inches in diameter, and the transparent, horizontal tube is 0.25 inches in diameter, how much differential pressure will be indicated by 1 inch of horizontal bubble displacement? Assume the use of water for the manometer liquid.

[file i00169](#)

Question 21

Determine what will happen at the following steps in the sequence (when prompted for a response) in this pressure transmitter calibration setup:

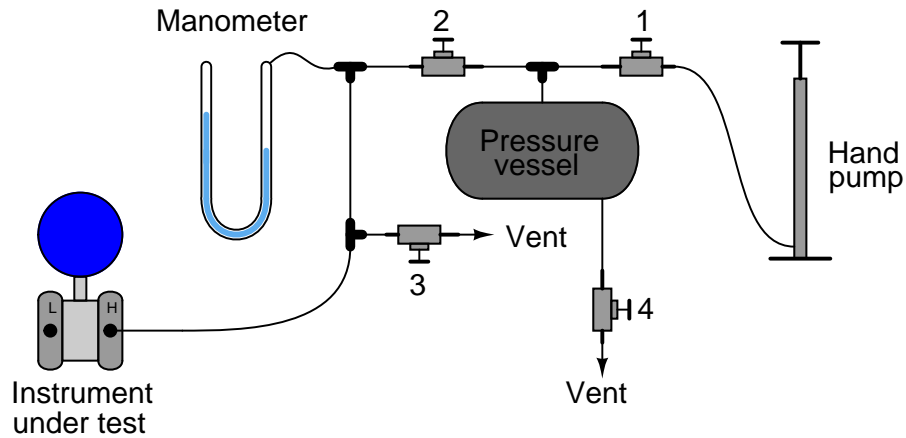

- **Step 1:** Open valves 1 and 2
- **Step 2:** Close valves 3 and 4
- **Step 3:** Operate hand pump until manometer registers maximum pressure
- **Step 4: (4 points)** Quickly open and close valve 4 – *does the manometer indication drop greatly, slightly, or not at all?*
- **Step 5:** Close valve 2
- **Step 6: (4 points)** Quickly open and close valve 4 – *does the manometer indication drop greatly, slightly, or not at all?*
- **Step 7:** Close valve 1
- **Step 8: (4 points)** Quickly open and close valve 3 – *does the manometer indication drop greatly, slightly, or not at all?*

file i00463

---

Question 22

Complete the following table of equivalent pressures:

PSIG	PSIA	inches Hg (G)	inches W.C. (G)
18			
	400		
		33	
			60
		452	
			12
	1		
-5			

There is a technique for converting between different units of measurement called “unity fractions” which is imperative for students of Instrumentation to master. For more information on the “unity fraction” method of unit conversion, refer to the “Unity Fractions” subsection of the “Unit Conversions and Physical Constants” section of the “Physics” chapter in your *Lessons In Industrial Instrumentation* textbook.

[file i02938](#)

---

Question 23

Complete the following table of equivalent pressures:

Atm	PSIG	inches W.C. (G)	PSIA
3.5			
	81		
		8834	
			0
		7.12	
			368
	2		
100			

There is a technique for converting between different units of measurement called “unity fractions” which is imperative for students of Instrumentation to master. For more information on the “unity fraction” method of unit conversion, refer to the “Unity Fractions” subsection of the “Unit Conversions and Physical Constants” section of the “Physics” chapter in your *Lessons In Industrial Instrumentation* textbook.

[file i02939](#)



---

Question 24

Explain what is wrong with this attempt to convert a gauge pressure of 65 PSI into units of atmospheres (atm):

$$\left(\frac{65 \text{ PSI}}{1}\right) \left(\frac{1 \text{ atm}}{14.7 \text{ PSI}}\right) = 4.422 \text{ atm}$$

**Suggestions for Socratic discussion**

- The mistake made here is common for new students to make as they learn to do pressure unit conversions. Identify a “sure-fire” way to identify and avoid this mistake.

[file i02940](#)

---

Question 25

2.036 inches of mercury (”Hg) is an equivalent pressure to 27.68 inches of water (”W.C. or ”H<sub>2</sub>O). This fact allows us to create a “unity fraction” from these two quantities for use in converting pressure units from inches mercury to inches water or vice-versa. Two examples are shown here:

$$\left(\frac{310 \text{ ”Hg}}{1}\right) \left(\frac{27.68 \text{ ”W.C.}}{2.036 \text{ ”Hg}}\right) = 4215 \text{ ”W.C.}$$

$$\left(\frac{45 \text{ ”W.C.}}{1}\right) \left(\frac{2.036 \text{ ”Hg}}{27.68 \text{ ”W.C.}}\right) = 3.31 \text{ ”Hg}$$

But what if we are performing a unit conversion where the initial pressure is given in inches of mercury or inches of water *absolute*? Can we properly make a unity fraction with the quantities 2.036 ”HgA and 27.68 ”W.C.A as in the following examples?

$$\left(\frac{310 \text{ ”HgA}}{1}\right) \left(\frac{27.68 \text{ ”W.C.A}}{2.036 \text{ ”HgA}}\right) = 4215 \text{ ”W.C.A}$$

$$\left(\frac{45 \text{ ”W.C.A}}{1}\right) \left(\frac{2.036 \text{ ”HgA}}{27.68 \text{ ”W.C.A}}\right) = 3.31 \text{ ”HgA}$$

Explain why or why not.

[file i02942](#)

Question 26

A pressure transmitter with a remote seal measures the pressure of a gas inside a process vessel. A pressure gauge directly attached to the vessel registers 19.3 PSI. The transmitter is located 22 feet 5 inches below this point, with a capillary tube filled with fluid having a specific gravity of 0.94:

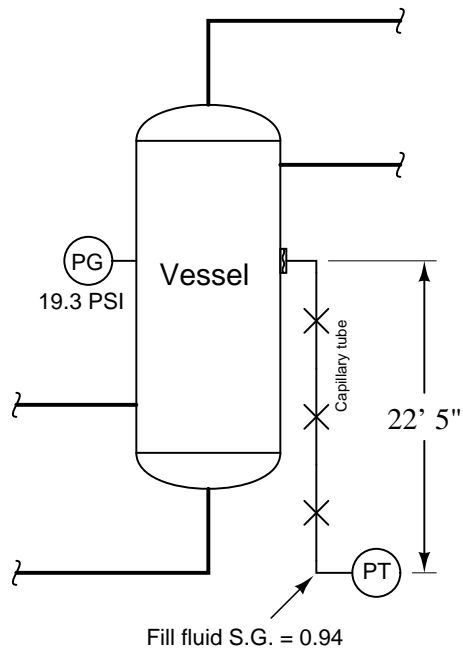

How much pressure will the transmitter register?  
file i00240

Question 27

A business owns a large storage tank which was used to hold water for fire protection. This tank is equipped with a pressure gauge at the bottom to infer water level. The face of the gauge reads out in feet of water rather than PSI or some other common pressure unit:

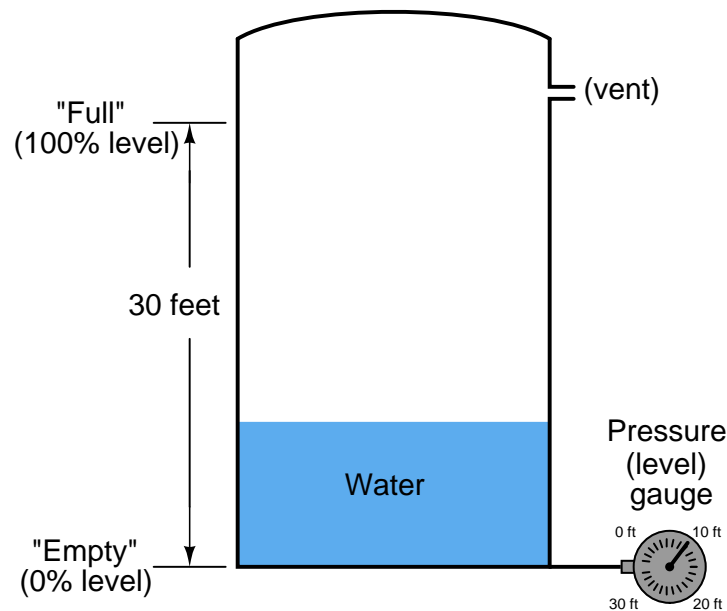

The operation of this level-indicating pressure gauge is quite simple: as the water level changes in the tank, the amount of hydrostatic pressure generated at the bottom changes proportionally.

When the local municipality upgrades the size of the water supply line to the company property, there is no longer a need for the fire-water storage tank. Not wanting to abandon the tank, a manager at the company decides to use it for gasoline fuel storage instead.

After emptying the water and re-filling the tank with gasoline, however, they notice a problem with the level-indicating gauge: it no longer reads correctly. With gasoline in the tank instead of water, the gauge's reading no longer correlates with tape-measure readings of liquid level like it used to. Instead, the gauge consistently registers low: there is always more gasoline in the tank than the gauge indicates.

Someone at this company asks you to explain what the problem is, because you have studied instrumentation technology. Describe the nature of the problem in your own words, and propose a solution to this problem that does not involve purchasing any new equipment.

**Suggestions for Socratic discussion**

- If there is actually 10 feet of gasoline in the tank, how many feet with the water-calibrated gauge read?

[file i02949](#)

Question 28

Calculate the amount of pressure applied to each side of the differential pressure transmitter (in units of PSI) when there is 9 feet of liquid level in the process vessel. Note the pressure gauge at the top of the vessel registering the amount of vapor pressure inside:

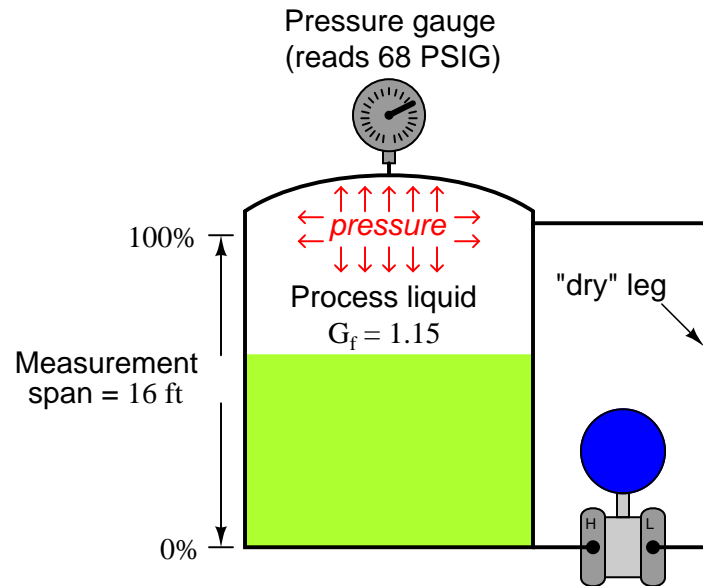

$$P_{high} = \text{_____ PSIG}$$

$$P_{low} = \text{_____ PSIG}$$

Also, calculate the *differential* pressure seen by the transmitter (in units of PSI):

$$\Delta P = \text{_____ PSID}$$

file i02950

Question 29

A tank expert system gives the following pressure indications from its three transmitters:

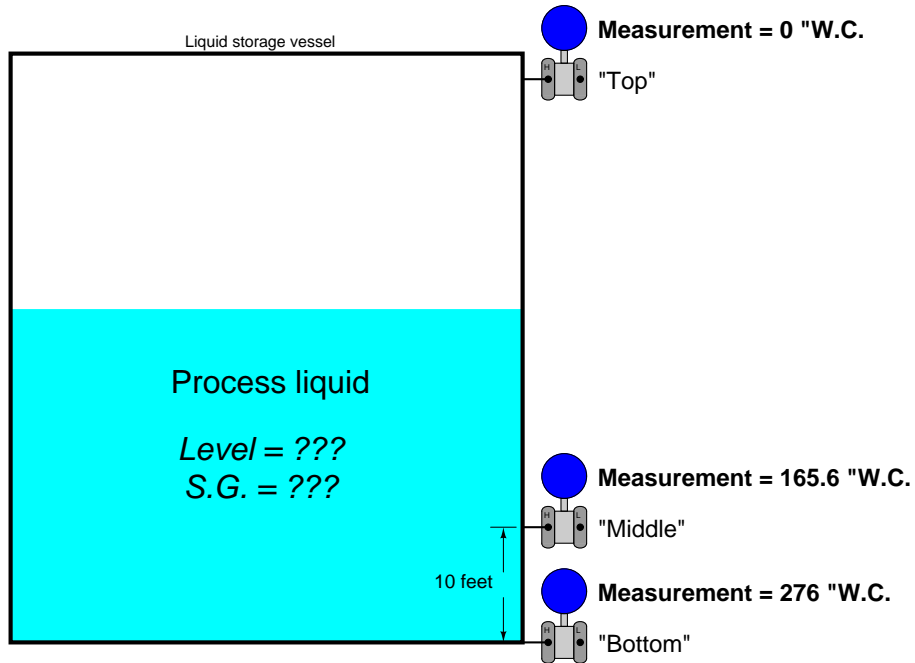

From these pressure measurements, determine the level of liquid in the vessel and its specific gravity. Be sure to explain how you obtained your answers!

file i00255

### Question 30

Two pressure-actuated “lifts” are used to raise a heavy weight off the ground. One lift uses oil under pressure (from a hydraulic pump) while the other lift uses air under pressure (from an air compressor). Each lift is equipped with a shut-off valve on the line feeding fluid to the cylinder, so that the piston’s motion may be halted:

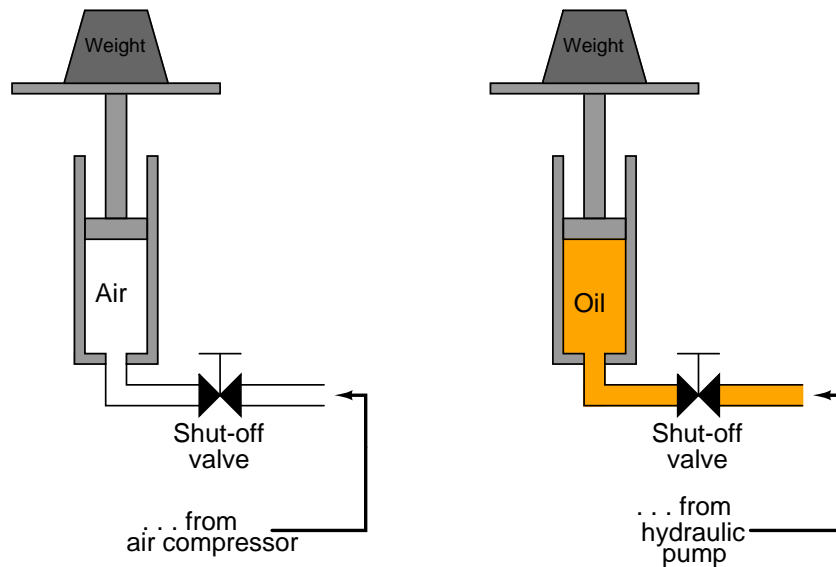

What will happen if the weight were to fall off the lift platform after it had been raised up from ground level, in each case? Assume that the shut-off valve is closed (no fluid flow from pump or compressor into the cylinder) when this happens.

#### Suggestions for Socratic discussion

- What general lessons may we draw from this example regarding pressurized fluid safety?
- Does the calculation of piston force based on pressure ( $F = PA$ ) change at all if the fluid in question is a *gas* rather than a *liquid*?

[file i00750](#)

Question 31

Calculate the necessary piston diameter for this air-over-oil car lift to enable it to lift a 6,000 pound vehicle with a maximum applied air pressure of 100 PSI:

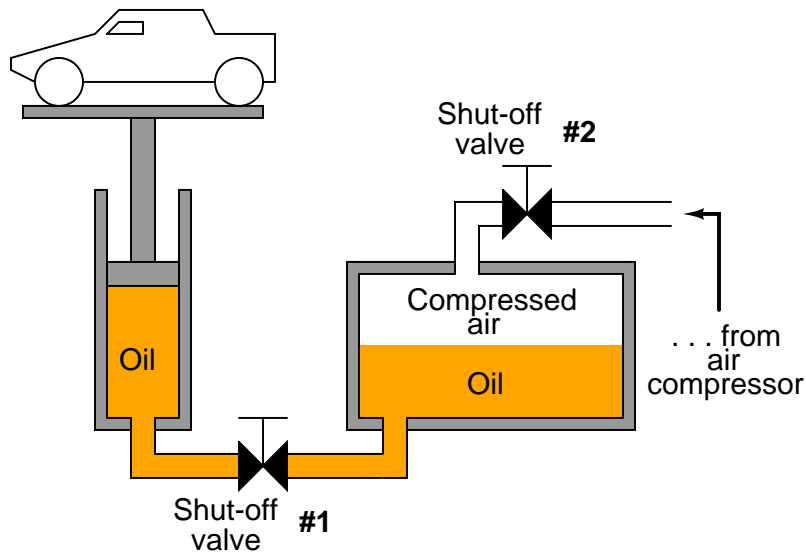

Suggestions for Socratic discussion

- Does the size of the oil reservoir matter in this calculation? Why or why not?

[file i03779](#)

Question 32

A free-floating piston inside a hydraulic cylinder has a 1000 PSI of fluid pressure applied to one side of the piston, and 850 PSI of pressure applied to the other side of the piston. The piston itself is 2.75 inches in diameter. How much force will act on the piston, with these pressures applied to it?

Force on piston ???

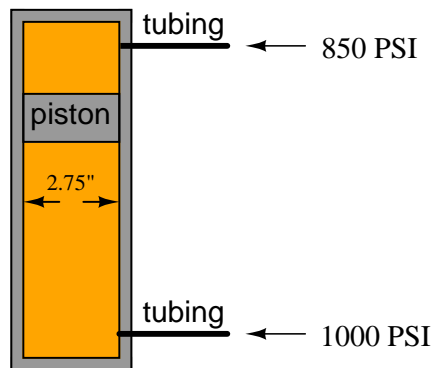

[file i00155](#)

### Question 33

A double-acting hydraulic cylinder has 500 PSI of pressure applied to the side without the rod and 750 PSI of pressure applied to the rod-side. Calculate the resultant force generated at the piston and transmitted through to the rod, and also determine this force's direction. The piston is 5 inches in diameter, and the rod is 1 inch in diameter.

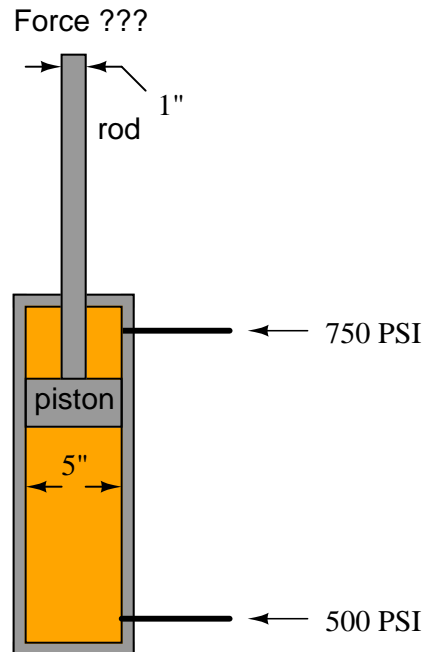

#### Suggestions for Socratic discussion

- Identify which fundamental principles of science, technology, and/or math apply to each step of your solution to this problem. In other words, be prepared to explain the reason(s) “why” for every step of your solution, rather than merely describing those steps.
- What would happen if fluid pressure were applied to the bottom port and a fluid *vacuum* were applied to the top port? Would this generate more force, less force, or the same amount of force as if the same fluid pressure were applied to bottom port and the top port left vented?
- Would the piston experience a resultant force if both ports were connected together with a length of tubing (made “common” to each other) and then pressurized with the exact same amount of fluid pressure? Why or why not?
- Suppose both ports of this cylinder were connected together with a length of tubing (made “common” to each other) and to a pressure gauge. What would that gauge register if the piston were then pushed in the downward direction? Would the gauge’s reading increase, decrease, or remain the same? Explain your answer in detail.

[file i00156](#)



---

Question 34

The following hydraulic system is made up of three cylinders connected together by the same tube:

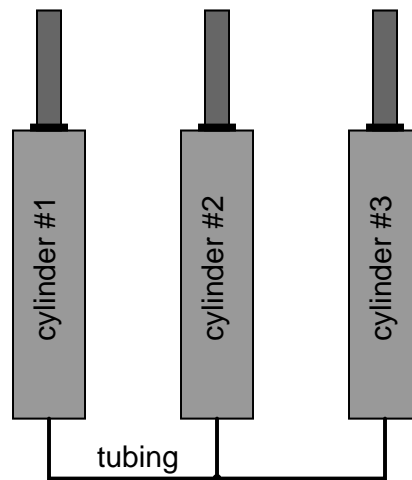

Assuming that all three pistons are the same size, calculate the force generated by the pistons of cylinders #2 and #3 if the piston of cylinder #1 is pushed with 500 pounds of force.

[file i00152](#)

Question 35

Calculate the force generated at the large piston (area =  $40 \text{ in}^2$ ), given a 25 pound force applied to the small piston (area =  $10 \text{ in}^2$ ). Also, calculate the pressures where the two pressure gauges are located, and explain how the hydrostatic pressure of the water column's 20 foot vertical height factors in to this force calculation.

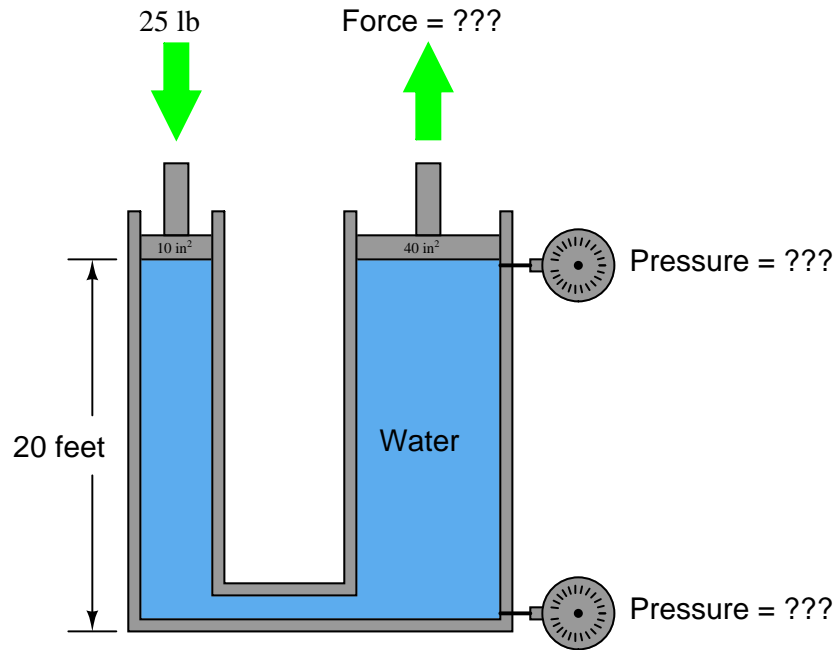

Does the disparity in pressure between the two gauge locations represent a violation of Pascal's Principle? Why or why not?

file i00159

Question 36

How much air pressure will be required to compress this valve actuator spring three-quarters of an inch, assuming it begins in a relaxed state with no air pressure applied? Assume a  $k$  value for the spring of 1340 lb/in, and a diaphragm diameter of 14 inches.

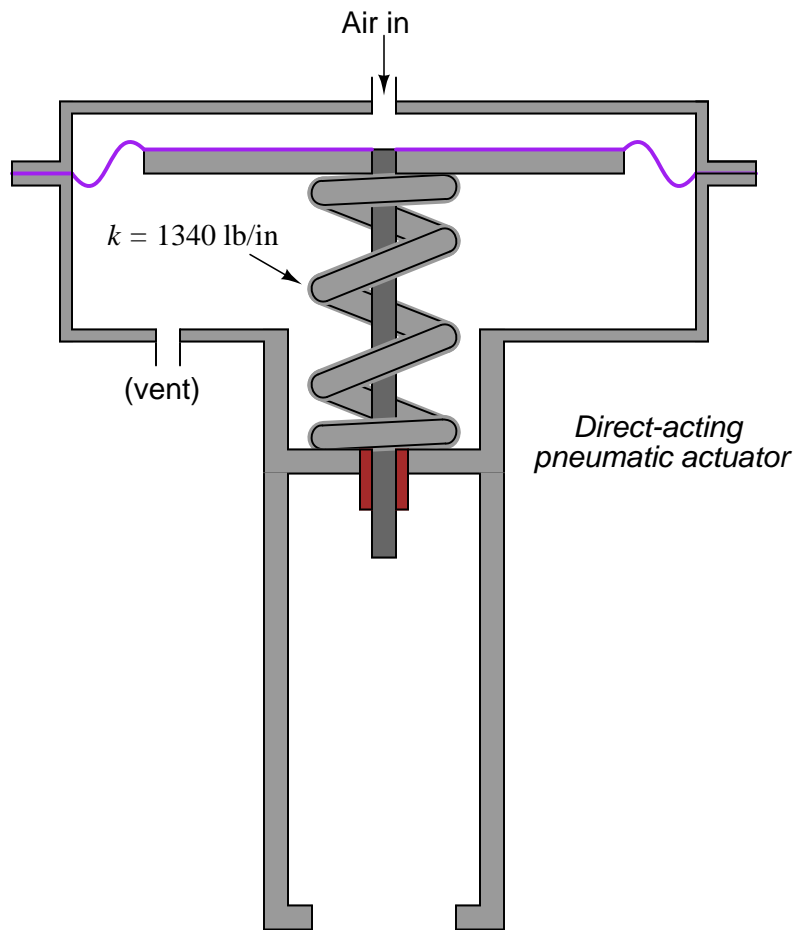

[file i03780](#)

Question 37

A process called *delayed coking* is used in the oil refining industry to convert heavy oils and tars into higher-valued petroleum products. A process vessel called a *coke drum* has a removable lid held down by a series of bolts, and alternatively by a hydraulic ram. When it comes time to open up the coke drum, the hydraulic ram is pressurized to maintain adequate force on the coke drum lid, the bolts are removed, and then the ram's fluid pressure is reduced until the lid springs open from the force of the gas pressure inside the coke drum:

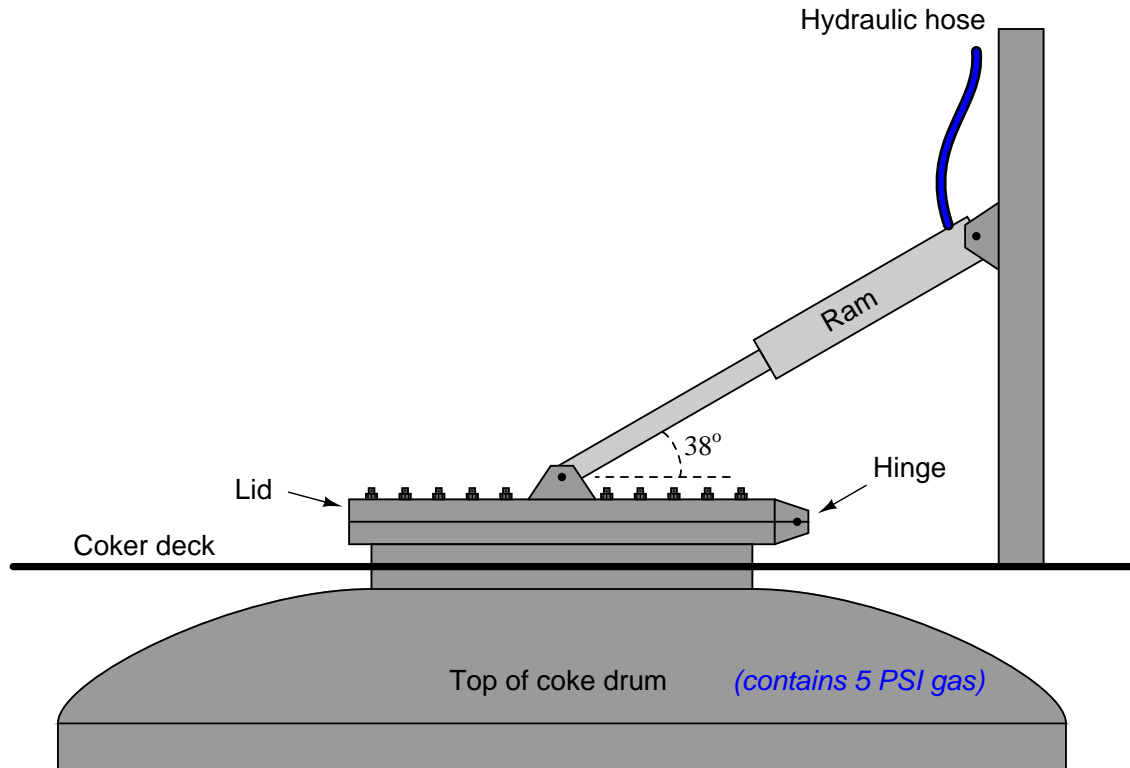

Calculate the hydraulic pressure necessary to hold down the lid on the coke drum when the gas pressure inside the drum is 5 PSI and all hold-down bolts have been removed from the lid. Assume a lid diameter of 30 inches, and a ram piston diameter of 4 inches. Hint: sketch a right triangle, representing forces as side lengths on the triangle – the ram's diagonal force will translate into both a horizontal force on the lid (which you may ignore) and a vertical force on the lid (which is what we're interested in here).

Hydraulic  $P =$  \_\_\_\_\_ PSI

**Suggestions for Socratic discussion**

- Which direction will the horizontal force component be exerted on the lid?
- Identify the potential hazards of a hydraulic oil leak in this system. Compare the effects of a slow leak (e.g. a leaky fitting connecting the hose to the ram) versus a catastrophic leak (e.g. the hose bursting from excess pressure).

[file i04683](#)

Question 38

A solid metal cube measuring exactly 1 inch on a side is submerged in an open container filled with water. The bottom of the cube is 24 inches down from the water's surface:

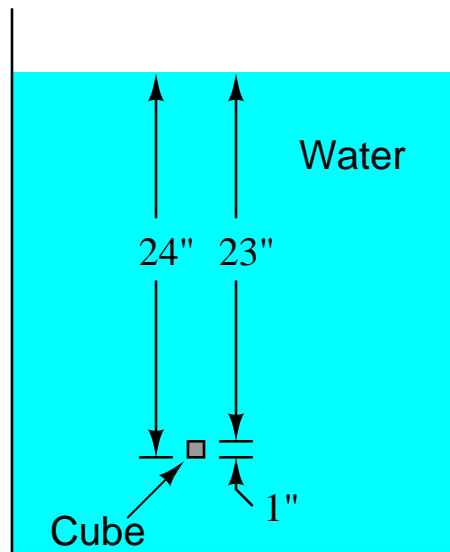

Based on your calculations of hydrostatic pressure (in PSI), determine the force applied to each side of the cube (in units of pounds), and the net, or *resultant* of these six forces (one force for each side of the cube).

Based on the figure for water density of  $62.428 \text{ lb/ft}^3$ , how much does one cubic inch of water happen to weigh?

file i00265

---

Question 39

A solid metal cube measuring exactly 4 inches on a side is submerged in an open container filled with methanol. The bottom of the cube is 10 inches down from the methanol's surface:

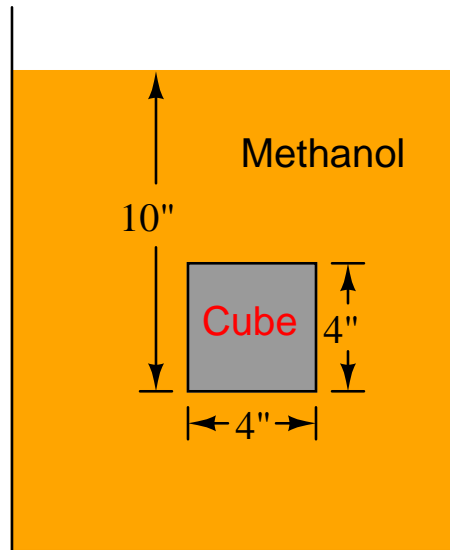

Based on your calculations of hydrostatic pressure (in PSI), determine the force applied to each side of the cube (in units of pounds), and the net, or *resultant* of these six forces (one force for each side of the cube).

Based on the figure for methanol density of  $49.41 \text{ lb/ft}^3$ , how much does 64 cubic inches of methanol (a  $4'' \times 4'' \times 4''$  cube) happen to weigh?

[file i00266](#)

---

Question 40

A king is given a shiny crown as a gift. The person giving the crown claims that it is made of pure, solid gold. It looks like gold, but the king – being wise to the ways of the world – knows that it might just be gold-plated tin or some other cheaper metal.

He hands his new crown over to a famous scientist to have it analyzed, with the command that the crown is not to be damaged in any way by the testing. The scientist ponders the task of determining the crown's composition nondestructively, and decides that a density measurement performed by weighing the crown both dry and submerged in water would suffice, since gold is substantially heavier than any cheap metal.

The crown weighs 5 pounds dry. When completely submerged in water, it weighs 4.444 pounds. Is it really made of solid gold?

[file i00273](#)

Answer 1

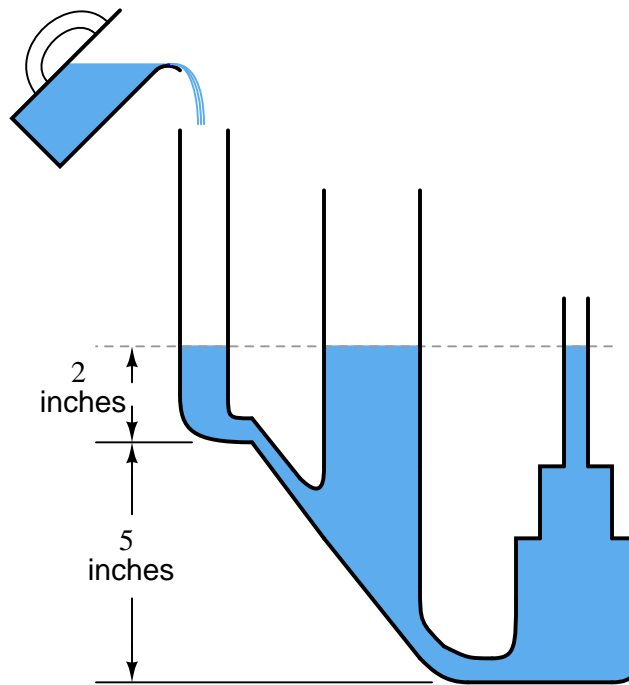
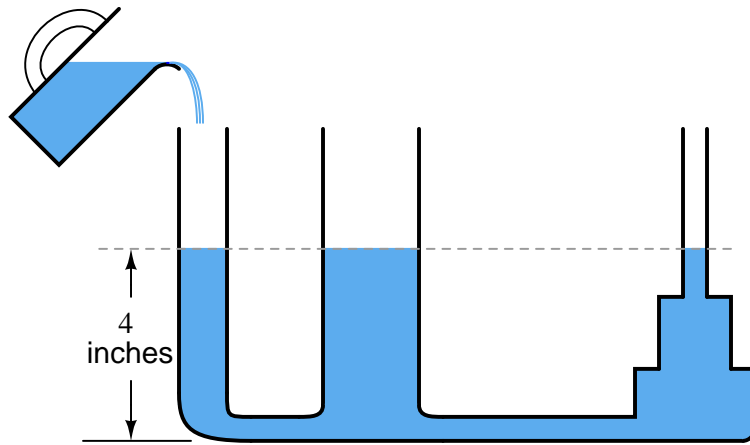

Answer 2

This is a “trick” question: they all generate the exact same amount of hydrostatic pressure.

The principle at work here is the relationship between *vertical* height and hydrostatic pressure. Cross-sectional area of the liquid column is irrelevant! Only column height, liquid density, and the gravitational pull of the Earth matter when calculating hydrostatic pressure. Since all three of these variables are precisely the same in this scenario, the hydrostatic pressures must likewise be precisely the same.

---

Answer 3

Specific gravity = 0.8669 (same as density in units of  $\text{g}/\text{cm}^3$ )

The units of grams and cubic centimeters are *defined* in such a way that their density quotient in relation to pure water is 1. This is similar to the Celsius temperature scale, similarly *defined* at the  $0^\circ$  and  $100^\circ$  points by the freezing and boiling points of pure water, respectively.

To calculate the density of toluene in units of pounds per cubic feet, simply multiply the density of water ( $62.428 \text{ lb}/\text{ft}^3$ ) by the specific gravity of toluene (0.8669):

$$(62.428 \text{ lb}/\text{ft}^3)(0.8669) = 54.12 \text{ lb}/\text{ft}^3$$

---

Answer 4

First liquid's specific gravity = 0.865

Second liquid's specific gravity = 0.9451

---

Answer 5

The fluid pressure will exert an outward force on the cylinder walls, like this:

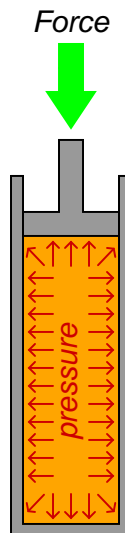



---

Answer 6

A pushing force on the rod will compress the rubber ball to a smaller diameter. A pulling force will expand it to a larger diameter.

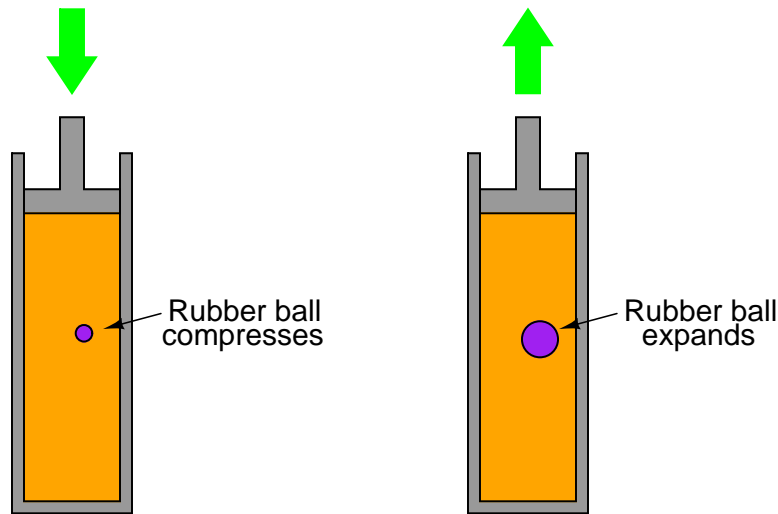

---

Answer 7

406.9 inches, which is a little bit less than 34 feet. For this amount of “lift height,” the pump would have to create a near-perfect vacuum in the inlet pipe. To calculate this figure, convert 14.7 PSIA into inches of water column absolute (14.7 PSIA)(2.768 ”W.C. / PSI).

Since this kind of water pump works by creating a vacuum (reducing the inlet pressure to something less than 14.7 PSIA), it is inherently limited in lift height. Since atmospheric pressure is always 14.7 PSIA (on Earth, anyway), this kind of pump simply cannot suck water any higher than this amount of pressure expressed in inches or feet of water.

The average barometric pressure in Denver is 24.63 inches of mercury absolute (12.097 PSIA). This equates to a water-lifting height of 334.9 inches, or 27.9 feet.

Submersible pumps overcome this limit by creating a *positive pressure* rather than a *vacuum*. The pumping action is therefore not limited by the relatively low pressure of Earth’s atmosphere, but only by the capacity and design of the pump itself:

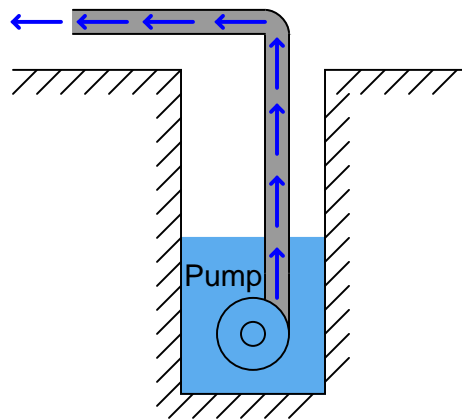

---

Answer 8

With no nozzle on the end of the hose, the end may be raised a maximum of 184.54 feet. With a nozzle in place, the hose end may be raised only 115.33 feet.

Essentially, this is just another pressure unit conversion problem: in this case, PSI-to-feet of water column. 80 PSI is equivalent to 184.54 feet, so that is how high 80 PSI can force a column of water.

With a nozzle attached to the end of the hose, though, we are only allowed to “drop” 50 feet of hydrostatic pressure, in order to leave 30 PSI remaining at the nozzle coupling for proper operation. 50 PSI is equivalent to 115.33 feet, so this is how high we may raise the hose end with a nozzle on it.

It must be understood that the first calculation is not a very practical one. 80 PSI of pressure at the hydrant will *just* push water 184.54 feet high. If the hose were 190 feet and poised vertically, there would be a column of water inside 184.54 feet tall, with no water at all coming out the end. If the hose end were brought exactly to a height of 184.54 feet, water would be right at the lip of the hose, not even trickling out. Obviously, some pressure is needed at the hose end in order to push water out onto a fire, so the *practical*, no-hose height for 80 PSI will be somewhat lower than 184.54 feet.

The hose-with-nozzle scenario is more realistic, because an actual figure for minimum hose-end pressure is given for us to incorporate into our calculations.

---

Answer 9

Weight of water = 117,674 lbs

Area of circular pool bottom = 45,239 in<sup>2</sup>

Pressure at bottom of pool =  $P = 2.601 \text{ lb/in}^2 \text{ (PSI)} = 72 \text{ inches of water column ("} \text{ W.C.)}$

---

Answer 10

$$\left( \frac{20 \text{ ft olive oil}}{1} \right) \left( \frac{0.918 \text{ ft W.C.}}{1 \text{ ft olive oil}} \right) \left( \frac{12 \text{ inches}}{1 \text{ ft}} \right) \left( \frac{6.895 \text{ kPa}}{27.6807 \text{ inches W.C.}} \right) = 54.88 \text{ kPa}$$

---

Answer 11

Hydrostatic pressure due to 3 feet of glycerine (SG = 1.26)

$$(1.26)(3 \text{ feet})(12 \text{ in} / 1 \text{ ft})(1 \text{ PSI} / 27.6807 \text{ "W.C.}) = 1.639 \text{ PSI}$$

Hydrostatic pressure due to 2 feet of water (SG = 1.00)

$$(1.00)(2 \text{ feet})(12 \text{ in} / 1 \text{ ft})(1 \text{ PSI} / 27.6807 \text{ "W.C.}) = 0.867 \text{ PSI}$$

Hydrostatic pressure due to 4.5 feet of olive oil (SG = 0.918)

$$(0.918)(4.5 \text{ feet})(12 \text{ in} / 1 \text{ ft})(1 \text{ PSI} / 27.6807 \text{ "W.C.}) = 1.791 \text{ PSI}$$

$$\text{Total hydrostatic pressure} = 1.639 \text{ PSI} + 0.867 \text{ PSI} + 1.791 \text{ PSI} = 4.297 \text{ PSI} = 29.6 \text{ kPa}$$

---

Answer 12

The accuracy of a manometer is fixed by two fundamental variables, both of which are quite constant:

- The density (mass per unit volume) of the manometer liquid
- The gravity of Earth

So long as these two variables do not change, neither will the accuracy of the manometer.

---

Answer 13

Applied pressure = 9 "W.C., which is equal to 0.32514 PSI.

For the same applied pressure, the distance between the two liquid columns will be *greater* than with water. In other words, for a pressure of 9" W.C., there will be *more* than 9 inches of vertical distance separating the two liquid columns.

Essentially, manometers work on the principle of balanced pressures: the applied gas pressure forces the liquid columns to shift height. When they do so, they generate a hydrostatic pressure proportional to their differential height. When this hydrostatic pressure equals the applied pressure, the liquid columns stop moving and a condition of equilibrium is reached.

If a lighter fluid such as oil is used instead of water, a greater height will have to be developed to generate the same amount of hydrostatic pressure to oppose the applied gas pressure and reach equilibrium. Conversely, if a heavier (denser) liquid such as mercury were to be used, a much smaller vertical height would develop between the two columns for the same pressure.

---

Answer 14

Pressure applied to right-hand tube = 26.5 "W.C = 6600.8 Pa.

Follow-up question: demonstrate how we could have arrived at an approximate answer by using rounded figures for our unit-conversion constants, and "mental math" instead of a calculator.

---

Answer 15

Applied pressure = 3.1875 "W.C., which is equal to 0.1152 PSI.

Follow-up question: demonstrate how we could have arrived at an approximate answer by using rounded figures for our unit-conversion constants, and "mental math" instead of a calculator.

---

Answer 16

Glycerine height = **38.46** ft

Castor oil height = **49.96** ft

---

Answer 17

19 inches of water and 15 inches of glycerine will balance one another in this manometer. These are not the only column heights that will self-balance. In fact, any ratio of 19:15 will work because the ratio of water's density to glycerine's density is 15:19.

---

Answer 18

Applied pressure = 2.5 "W.C.

What matters in manometer calculations is the *vertical* height difference between the two liquid columns. Inclining one or more of the tubes only causes the liquid to displace further along the tube(s); it does not change the vertical height necessary to balance the applied pressure.

Thus, with a 30° inclined tube, a liquid displacement of 5 inches along the length of the tube equates to one-half that ( $\sin 30^\circ = 0.5$ ). Therefore, the applied pressure is 2.5 inches of water column.

Note that the inclined manometer makes very sensitive pressure measurements possible using standard-density liquids such as water! Great care, though, must be taken in ensuring the instrument is level (that the inclined tube is at precisely the angle it should be).

---

Answer 19

**Partial answer:**

What matters here is the *vertical* height of the water column, not the angled length. Essentially, this is nothing more than a problem in trigonometry: to find the length of the side opposite the 40° angle, given a hypotenuse of 10 feet (120 inches).

---

Answer 20

1 inch of bubble motion represents 0.02 inches of water column pressure (differential), or 2/100 "W.C., applied across this micromanometer.

To solve for this pressure, first determine the amount of liquid volume that would have to be displaced to move the bubble 1 inch. Since the bubble resides in a tube 0.25 inches in diameter, the volume for 1 inch of bubble motion is:

$$(1 \text{ inch})[\pi(0.25 \text{ inch} / 2)^2] = 0.04909 \text{ in}^3$$

This is a very small amount of liquid volume! The water levels in the larger (2.5 inch diameter) tubes will not have to change much to accommodate this tiny amount of displacement. Dividing the displaced fluid volume by the area of the vertical tubes will tell us how far the water levels must change in each of the vertical tubes:

$$(0.04909 \text{ in}^3) / [\pi(2.5 \text{ inch} / 2)^2] = 0.01 \text{ inch}$$

So, a vertical liquid column height change of only 0.01 inch will cause a horizontal bubble displacement of 1 inch. Since there will be 0.01 inch of movement in *each* vertical tube, the combined total vertical displacement is twice this figure, or 0.02 inches of water column.

A much simpler way to solve this problem is to recognize that the vertical tube areas are 100 times as great as the horizontal tube (2.5 inches is ten times as large as 0.25 inches, and area is proportional to diameter *squared*), so 1 inch of horizontal fluid displacement is proportional to 1/100 inch of vertical fluid displacement. Once again, since *each* vertical tube experiences 0.01 inch of vertical water level displacement, the total water column shift is 0.02 inches.

---

Answer 21

- **Step 4:** Quickly open and close valve 4 – manometer indication drops **slightly**
- **Step 6:** Quickly open and close valve 4 – manometer indication **does not drop** at all
- **Step 8:** Quickly open and close valve 3 – manometer indication drops **greatly**

---

Answer 22

PSIG	PSIA	inches Hg (G)	inches W.C. (G)
18	32.7	36.65	498.25
385.3	400	784.5	10665
16.21	30.91	33	448.6
2.168	16.87	4.413	60
222.0	236.7	452	6145.1
0.4335	15.13	0.8826	12
-13.7	1	-27.89	-379.2
-5	9.7	-10.18	-138.4

---

Answer 23

Atm	PSIG	inches W.C. (G)	PSIA
3.5	36.75	1017.3	51.45
6.51	81	2242	95.7
22.71	319.1	8834	333.8
0	-14.7	-406.9	0
1.017	0.2572	7.12	14.96
25.03	353.3	9779.6	368
1.136	2	55.36	16.7
100	1455.3	40284	1470

---

Answer 24

The given pressure is in units of PSI *gauge* (PSIG), while the final unit (atmospheres) is an *absolute* pressure unit. In order for this conversion to be correct, there must somewhere be an offset (addition) in the calculation to account for the 14.7 PSI shift between gauge pressure and absolute pressure.

Here is the proper conversion technique:

$$\text{Step 1: } 65 \text{ PSIG} + 14.7 \text{ PSI} = 79.7 \text{ PSIA}$$

$$\text{Step 2: } \left( \frac{79.7 \text{ PSIA}}{1} \right) \left( \frac{1 \text{ atm}}{14.7 \text{ PSIA}} \right) = 5.422 \text{ atm}$$

---

Answer 25

This is perfectly legitimate, because in either case all the pressure units involved in each conversion are of the same type: either all gauge or all absolute. Where we encounter difficulties is if we try to mix different units in the same “unity fraction” conversion that do not share a common zero point.

A classic example of this mistake is trying to do a temperature conversion from degrees F to degrees C using unity fractions (e.g.  $100^\circ \text{C} = 212^\circ \text{F}$ ):

$$\left(\frac{60^\circ \text{F}}{1}\right) \left(\frac{100^\circ \text{C}}{212^\circ \text{F}}\right) \neq 28.3^\circ \text{C}$$

This cannot work because the technique of unity fractions is based on proportion, and there is no simple proportional relationship between degrees F and degrees C; rather, there is an *offset* of 32 degrees between the two temperature scales. The only way to properly manage this offset in the calculation is to include an appropriate addition or subtraction (as needed).

However, if there is no offset between the units involved in a conversion problem, there is no need to add or subtract anything, and we may perform the entire conversion using nothing but multiplication and division (unity fractions). Such is the case if we convert pressure units that are all gauge, or if we convert pressure units that are all absolute.

To summarize, it is perfectly acceptable to construct a unity fraction of  $\frac{27.68 \text{ "W.C.}}{2.036 \text{ "Hg}}$  because 0 "W.C. is the same as 0 "Hg (i.e. they share the same zero point; there is no offset between units "W.C. and "Hg). Likewise, it is perfectly acceptable to construct a unity fraction of  $\frac{27.68 \text{ "W.C.A}}{2.036 \text{ "HgA}}$  because 0 "W.C.A is the same as 0 "HgA (i.e. they share the same zero point; there is no offset between units "W.C.A and "HgA).

---

Answer 26

The transmitter will measure 28.4 PSI, due to the added pressure of the fluid inside the capillary tube.

---

Answer 27

The problem is that gasoline is less dense than water: for the same liquid height in the tank, gasoline generates less hydrostatic pressure than water. The solution is to re-calibrate the gauge!

Answer to Socratic question: the gauge will register about 6.7 feet of liquid. The density of gasoline varies between 41 and 43 pounds per cubic foot, so the range of possibilities here for gauge reading is 6.57 feet to 6.89 feet.

---

Answer 28

$$P_{high} = \mathbf{72.487 \text{ PSIG}}$$

$$P_{low} = \mathbf{68 \text{ PSIG}}$$

$$\Delta P = \mathbf{4.487 \text{ PSID}}$$

The “Top” transmitter’s indication of 0 inches water column tells us that the vessel is vented, or at least there is no vapor pressure buildup in it. This makes the task of determining level and density from the other two pressure measurements that much easier.

Determining specific gravity would be the best step to do first, before trying to determine liquid level. Once the liquid’s density is known, its level may be easily calculated from the “Bottom” transmitter’s pressure measurement.

With 10 feet of vertical distance separating the “Bottom” and “Middle” transmitters, there should be 120 inches (10 feet × 12 inches/foot) of water column pressure *difference* between the two transmitters’ measurements if the liquid in question had a specific gravity equal to 1, like water. In this case, though, there is a pressure difference of only 110.4 inches between the two measurements:

$$(276 \text{ "W.C.}) - (165.6 \text{ "W.C.}) = 110.4 \text{ "W.C.}$$

The discrepancy between 120 inches water column and 110.4 inches water column is due to one factor and one factor only: the liquid’s density. We may find the density by dividing the actual pressure difference by the expected pressure difference assuming a density equal to water:

$$\text{Specific gravity} = (110.4 \text{ "W.C.} / 120 \text{ "W.C.}) = 0.92$$

Therefore, the liquid held in this vessel has a specific gravity of 0.92, meaning that its density is 92% that of water. Knowing the liquid density, we calculate the liquid level by re-working the liquid column pressure equation to solve for height:

$$P = hG$$

$$\frac{P}{G} = h$$

Where,

$P$  = hydrostatic pressure in inches water column

$h$  = liquid column height in inches

$G$  = specific gravity of liquid

$$(276 \text{ "W.C.}) / (0.92 \text{ "W.C.} / \text{in}) = 300 \text{ inches}$$

So, the answer for liquid level is 300 inches, or 25 feet.

Answer 30

If the weight falls off the oil-actuated lift, the piston will hold its original position. If the weight falls off the air-actuated lift, the piston will rise substantially (perhaps even ejecting from the cylinder!) due to expansion of the air:

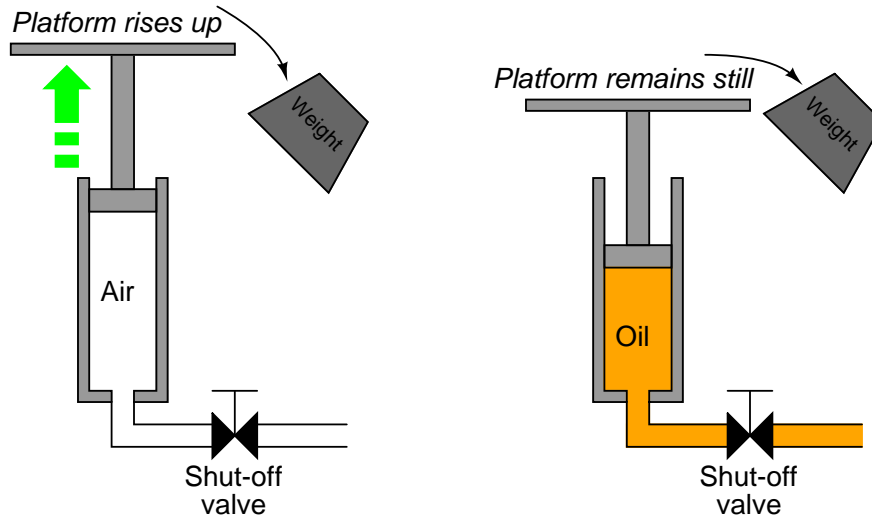

Answer 31

$$P = \frac{F}{A}$$

$$A = \frac{F}{P}$$

$$A = \frac{6000 \text{ lb}}{100 \text{ PSI}}$$

$$A = 60 \text{ in}^2$$

$$A = \pi r^2$$

$$r = \sqrt{\frac{A}{\pi}}$$

$$r = \sqrt{\frac{60 \text{ in}^2}{\pi}}$$

$$r = 4.37 \text{ inches}$$

So, the minimum piston diameter must be 8.74 inches.



---

Answer 32

Net piston force = 890.936 pounds.

In this scenario, there are two pressures fighting against each other: the 850 PSI pressure is pressing downward on the piston while the 1000 PSI pressure is pressing upward. The resultant (differential) pressure is 150 PSI (1000 PSI - 850 PSI). This is the pressure figure to be used in the final force calculation.

---

Answer 33

Net force = **4,319.69 pounds**, in the downward direction.

If your calculated force turned out to be 4,908.7 pounds, you made a very common error. Once you have figured out what this error is, go back and try to see how the scenario would have to be altered in order to actually generate 4,908.7 pounds of force with the two pressures being 750 PSI and 500 PSI, respectively.

---

Answer 34

The force generated at each of the other two pistons will be the same: 500 pounds. If you were thinking that the 500 applied pound force to cylinder #1's piston would somehow be divided between the other two pistons, you need to carefully re-consider the pressure/force/area equation.

---

Answer 35

Force at large piston = 100 pounds.

The upper pressure gauge will register 2.5 PSI, and the lower pressure gauge will register 11.17 PSI.

Pascal's Principle may be accurately stated as follows:

"Pressure applied to a confined fluid increases the pressure throughout that fluid volume by the same amount"

Mathematically, we can express Pascal's Principle as follows:

$$\Delta P_1 = \Delta P_2$$

It would be wrong to assume pressure throughout a confined fluid volume is the same (i.e.  $\Delta P_1 = \Delta P_2$ ), because that would preclude hydrostatic pressure which is dependent on height. It is more accurate to state Pascal's Principle in terms of pressure *increase*.

---

Answer 36

The necessary compression force is 1005 pounds (1340 lb/in  $\times$  0.75 in). With a diaphragm area of 153.9 square inches, this yields a pressure of 6.53 pounds per square inch.

---

Answer 37

With a piston diameter of 4 inches, a hydraulic pressure of 456.83 PSI is necessary to generate 5740.6 pounds. This is a *minimum* pressure, for safety reasons. More than 456.83 PSI won't do any harm, but less than this amount will fail to hold down the lid!

---

Answer 38

Force pushing up on cube's bottom face: 0.867 lb

Force pushing down on cube's top face: 0.831 lb

Average force pushing horizontally on each of the cube's four other faces: 0.849 lb

Resultant force = 0.0361 lb (upward) = weight of 1 in<sup>3</sup> of water @ 62.428 lb/ft<sup>3</sup>.

---

Answer 39

Force pushing up on cube's bottom face: 4.575 lb

Force pushing down on cube's top face: 2.745 lb

Average force pushing horizontally on each of the cube's four other faces: 3.660 lb

Resultant force: 1.830 lb (upward) = weight of 64 in<sup>3</sup> of methanol @ 49.41 lb/ft<sup>3</sup>.

---

Answer 40

First, determine the specific gravity of the crown. If it weighs 5 pounds dry and 4.444 pounds submerged, then the weight of the displaced water must be 0.556 pounds. A crown weighing 5 pounds, and having a volume equivalent to 0.556 pounds of water, must have a density approximately 9 times that of water ( $5 / 0.556 \approx 9$ ). We can say it has a specific gravity of 9, or say that it has a density of 9 g/cm<sup>3</sup>.

Pure gold has a specific gravity of almost 19, so this crown cannot be made of pure, solid gold. It is most likely made of copper ( $D = 8.96 \text{ g/cm}^3$ ) or tin ( $D = 7.31 \text{ g/cm}^3$ ), plated with gold.

According to legend, this is how Archimedes came up with his principle relating displacement to buoyant force.