

## Reading analog scales

This worksheet and all related files are licensed under the Creative Commons Attribution License, version 1.0. To view a copy of this license, visit <http://creativecommons.org/licenses/by/1.0/>, or send a letter to Creative Commons, 559 Nathan Abbott Way, Stanford, California 94305, USA. The terms and conditions of this license allow for free copying, distribution, and/or modification of all licensed works by the general public.

As a general rule of thumb, you should not attempt to interpolate analog indications lying between minor divisions to any resolution less than  $\frac{1}{2}$  of a division. If the pointer of the analog instrument falls between two division marks, “round” its position as either being on the low mark, on the high mark, or exactly between the two marks, whichever is closest.

## Questions

### Question 1

Interpret the pressure measurement displayed by this gauge mechanism, assuming a gauge accuracy of  $\pm 1\%$  full scale:



How low and how high could this pressure actually be, given the stated accuracy of this gauge?  
[file i01130](#)

Question 2

Interpret the pressure measurement displayed by this gauge mechanism, assuming a gauge accuracy of  $\pm 2\%$  full scale:

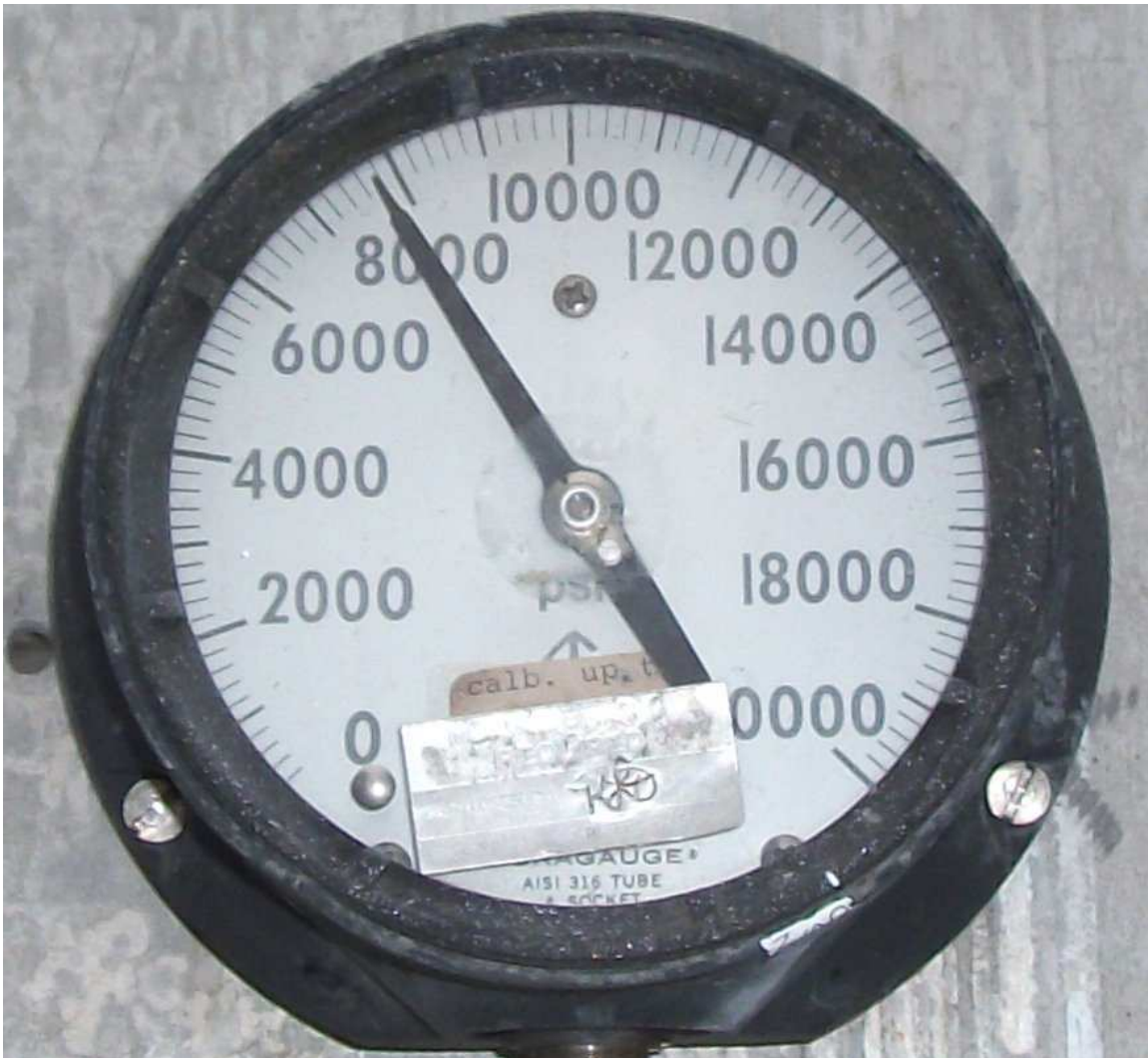

How low and how high could this pressure actually be, given the stated accuracy of this gauge?  
[file i01153](#)

---

Question 3

Interpret the pressure measurement displayed by this gauge mechanism, assuming a gauge accuracy of  $\pm 0.5\%$  full scale:



How low and how high could this pressure actually be, given the stated accuracy of this gauge?  
[file i01154](#)

Question 4

Interpret the pressure measurement displayed by this gauge mechanism, assuming a gauge accuracy of  $\pm 2\%$  full scale:



How low and how high could this pressure actually be, given the stated accuracy of this gauge?  
[file i01155](#)

Question 5

Interpret the pressure measurement displayed by this gauge mechanism, assuming a gauge accuracy of  $\pm 2\%$  full scale:

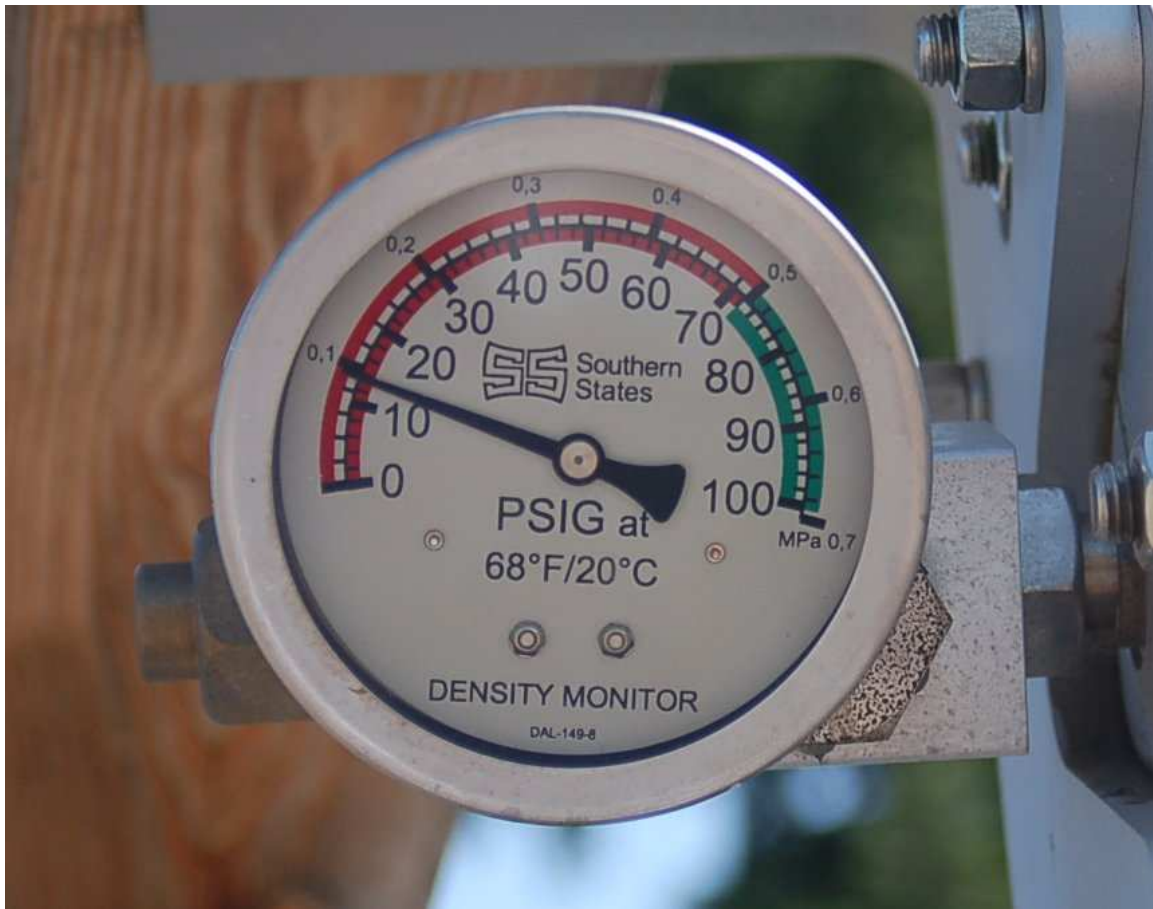

How low and how high could this pressure actually be, given the stated accuracy of this gauge?  
[file i02062](#)

Question 6

Interpret the pressure measurement displayed by this U-tube manometer, recalling that the pressure will be equal to the *difference* in heights between the two liquid columns:

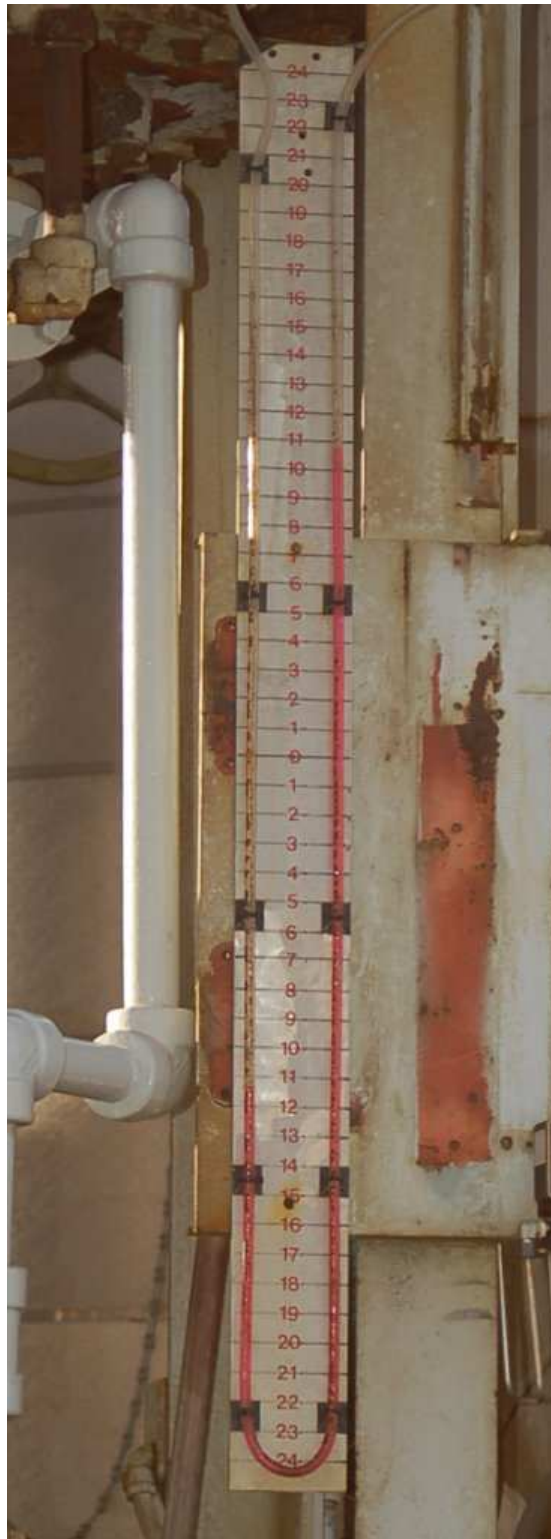

Question 7

Interpret the temperature measurement displayed by this gauge mechanism, and also identify the meaning of the *other* pointer:





Question 8

Interpret the measurement displayed by this pneumatic controller:



[file i02064](#)

Question 9

Interpret the air flow measurement displayed by this rotameter:



file i02065

Question 10

Machinists use a tool called *calipers* to measure short distances such as the outside diameter of a shaft. One particular type of caliper has a special scale that slides along with the movable jaw called a *vernier* scale. The spacing between divisions on the vernier scale is slightly less than the spacing between divisions on the main scale, which means only one division on the vernier scale will ever line up with a division on the main scale at any given time:

In order to obtain a coarse measurement of the caliper's jaw position, read the main scale using the "0" mark on the vernier scale as a pointer:

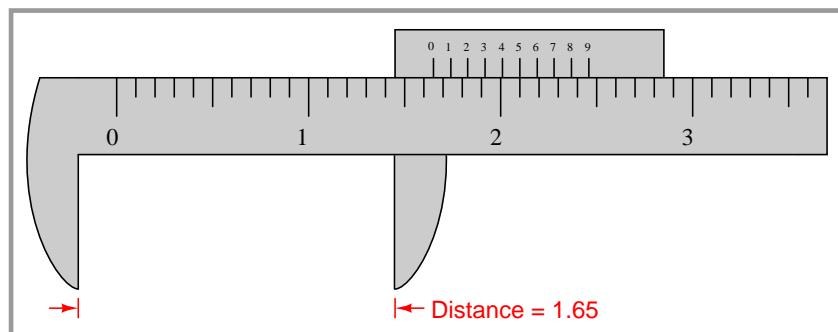
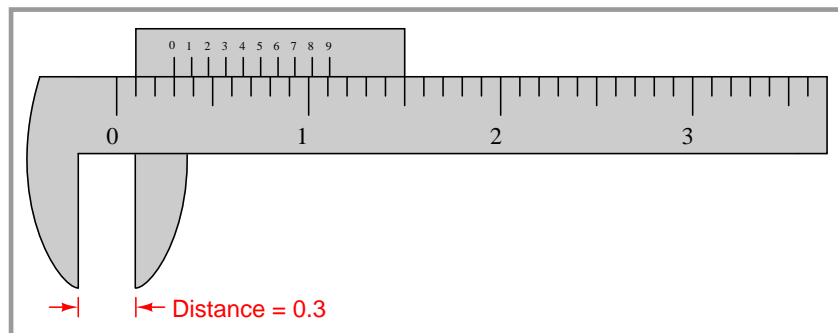
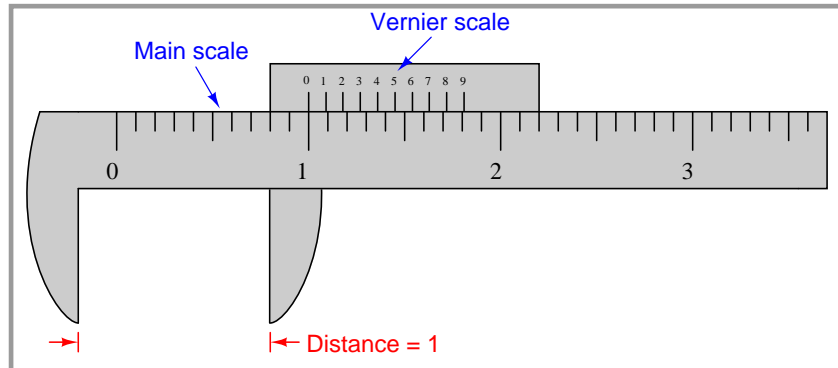

Now, use the vernier scale to read the distance between the caliper's jaws, when the "0" division on the vernier scale does *not* line up perfectly with one of the divisions on the main scale:

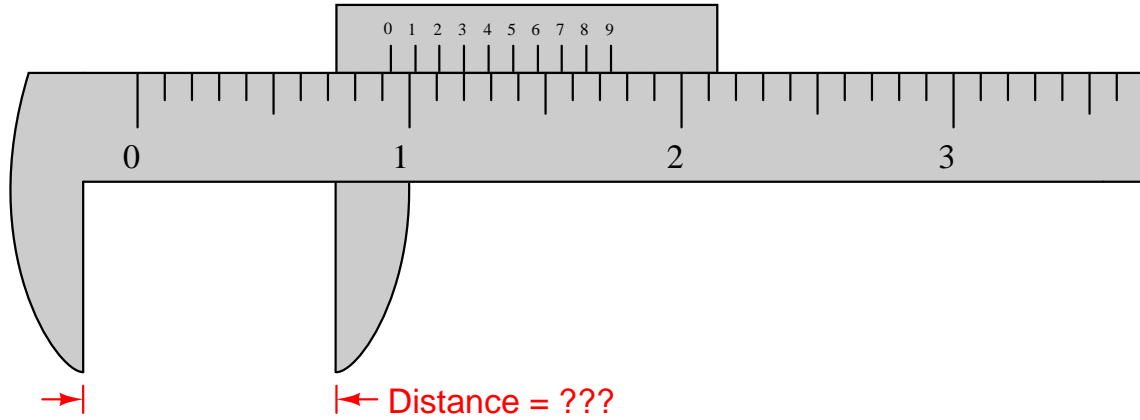

[file i01128](#)

---

Question 11

Interpret the distance between the jaws of this *vernier* caliper:

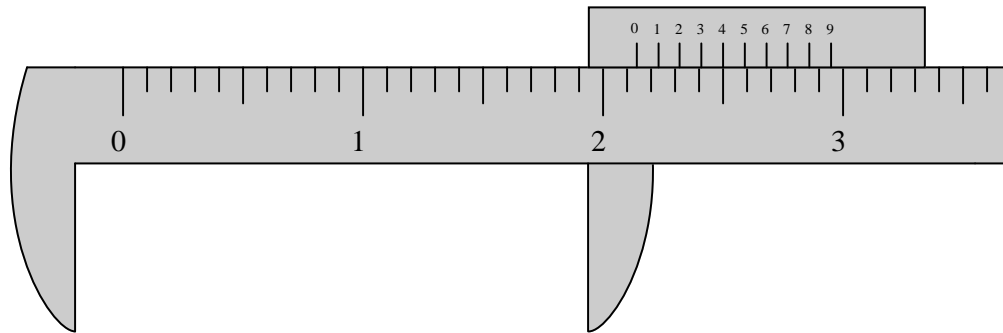

[file i01127](#)

---

Question 12

Some precision manometers are equipped with a *vernier* scale in order to make very precise measurements of liquid column height.

Interpret the reading shown on this mercury manometer. Note: the “hairline” on the moving vernier scale is adjusted to the meniscus height by a screw prior to taking the reading:

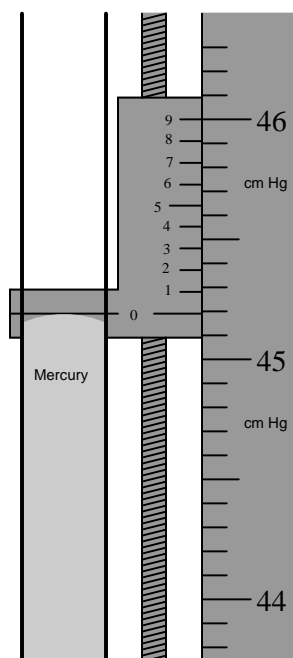

[file i01129](#)

## Answers

---

Answer 1

$$\text{Pressure} = 3750 \text{ PSI} \pm 60 \text{ PSI}$$

This means the actual pressure could be as low as 3690 PSI or as high as 3810 PSI.

---

Answer 2

$$\text{Pressure} = 7800 \text{ PSI} \pm 400 \text{ PSI}$$

This means the actual pressure could be as low as 7400 PSI or as high as 8200 PSI.

---

Answer 3

$$\text{Pressure} = 560 \text{ PSI} \pm 5 \text{ PSI}$$

This means the actual pressure could be as low as 555 PSI or as high as 565 PSI.

---

Answer 4

Pressure =  $2.5 \text{ "H}_2\text{O} \pm 0.6 \text{ "H}_2\text{O}$ . This means the actual pressure could be as low as  $1.9 \text{ "H}_2\text{O}$  or as high as  $3.1 \text{ "H}_2\text{O}$ .

If you look closely at the photograph, you can see that the camera's angle to the gauge face is not straight-on, and therefore there will be some *parallax error* in reading this gauge's face. If we were to lower the camera's view to get a more direct look at the gauge, we might see the needle pointing between the 2.5 and 3 divisions, which would mean a pressure of  $2.75 \text{ "H}_2\text{O} \pm 0.6 \text{ "H}_2\text{O}$ .

---

Answer 5

$$\text{Pressure} = 14 \text{ PSI} \pm 2 \text{ PSI}$$

This means the actual pressure could be as low as 12 PSI or as high as 16 PSI.

---

Answer 6

The pressure difference is approximately 22 inches of liquid column.

---

Answer 7

The current temperature is 40 degrees Celsius (red pointer), and the other pointer is a low-temperature capture. In this case, the "capture" pointer shows that the temperature went down as low as 20 degrees Celsius (or perhaps a bit lower, since parallax error is making that pointer appear to read higher than it actually is).

---

Answer 8

The red pointer shows 61% process level. The setpoint is a few percent less than that.

---

Answer 9

Rounding to the nearest half-division, we see the center of the ball-plummet nearest the "1" mark. No units of measurement are specified on the scale (from this viewing angle, anyway), and so we cannot say if this is 1 SCFH, 1 SCFM, or anything else.

---

Answer 10

$$\text{Distance} = 0.93$$

---

Answer 11

2.14 units

---

---

Answer 12

A pressure of **45.19 cm** of mercury is shown on this manometer.