

## Pictorial circuit diagrams

This worksheet and all related files are licensed under the Creative Commons Attribution License, version 1.0. To view a copy of this license, visit <http://creativecommons.org/licenses/by/1.0/>, or send a letter to Creative Commons, 559 Nathan Abbott Way, Stanford, California 94305, USA. The terms and conditions of this license allow for free copying, distribution, and/or modification of all licensed works by the general public.

## Questions

---

### Question 1

Draw connecting wires that will create a *series* circuit with all the components shown:

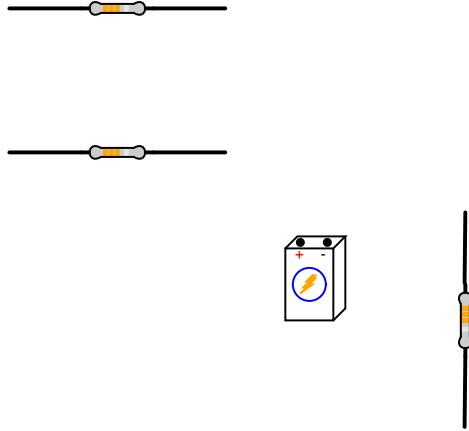

### Suggestions for Socratic discussion

- Supposing the battery has a voltage of 9 volts, and all resistors are  $1\text{ k}\Omega$  in resistance value, calculate the voltage dropped by each resistor.
- Supposing the battery has a voltage of 9 volts, and all resistors are  $1\text{ k}\Omega$  in resistance value, calculate the current passing through each resistor as well as the current passing through the battery.

[file i03800](#)

---

Question 2

Draw connecting wires that will create a *parallel* circuit with all the components shown:

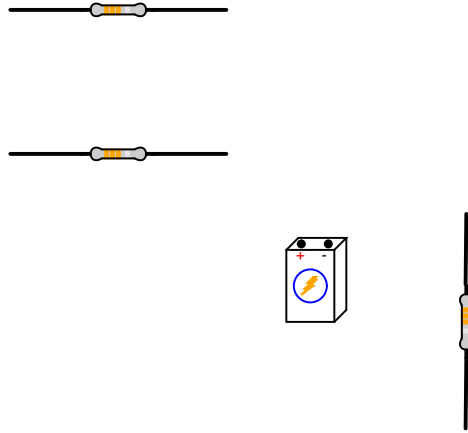

**Suggestions for Socratic discussion**

- Supposing the battery has a voltage of 6 volts, and all resistors are  $1\text{ k}\Omega$  in resistance value, calculate the voltage dropped by each resistor.
- Supposing the battery has a voltage of 6 volts, and all resistors are  $1\text{ k}\Omega$  in resistance value, calculate the current passing through each resistor as well as the current passing through the battery.

[file i03813](#)

---

Question 3

Draw connecting wires that will create a *series* circuit, such that current (conventional flow notation) will follow the directions shown by the arrows near each resistor:

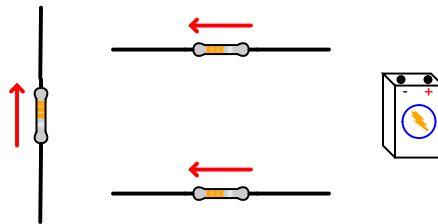

**Suggestions for Socratic discussion**

- Supposing the battery has a voltage of 12 volts, and all resistors are  $1\text{ k}\Omega$  in resistance value, calculate the voltage dropped by each resistor.
- Supposing the battery has a voltage of 12 volts, and all resistors are  $1\text{ k}\Omega$  in resistance value, calculate the current passing through each resistor as well as the current passing through the battery.

[file i03801](#)

---

Question 4

Draw connecting wires that will create a *parallel* circuit, such that current (conventional flow notation) will follow the directions shown by the arrows near each resistor:

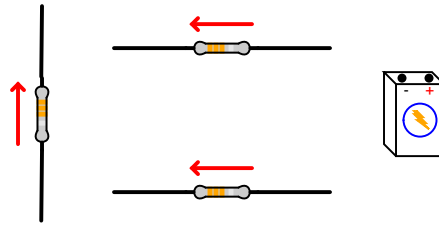

**Suggestions for Socratic discussion**

- Supposing the battery has a voltage of 3 volts, and all resistors are  $1\text{ k}\Omega$  in resistance value, calculate the voltage dropped by each resistor.
- Supposing the battery has a voltage of 3 volts, and all resistors are  $1\text{ k}\Omega$  in resistance value, calculate the current passing through each resistor as well as the current passing through the battery.

[file i03814](#)

---

Question 5

Draw connecting wires that will create a *series* circuit, such that current (conventional flow notation) will follow the directions shown by the arrows near each resistor:

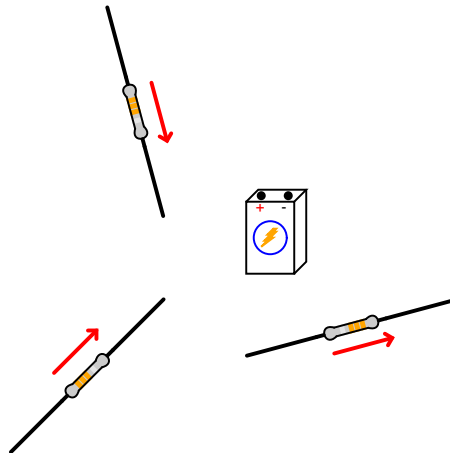

**Suggestions for Socratic discussion**

- Supposing the battery has a voltage of 4 volts, and all resistors are  $1\text{ k}\Omega$  in resistance value, calculate the voltage dropped by each resistor.
- Supposing the battery has a voltage of 4 volts, and all resistors are  $1\text{ k}\Omega$  in resistance value, calculate the current passing through each resistor as well as the current passing through the battery.

[file i03802](#)

---

Question 6

Draw connecting wires that will create a *parallel* circuit, such that current (conventional flow notation) will follow the directions shown by the arrows near each resistor:

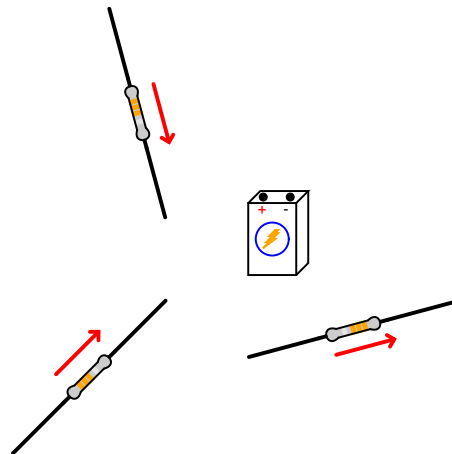

**Suggestions for Socratic discussion**

- Supposing the battery has a voltage of 8 volts, and all resistors are  $1\text{ k}\Omega$  in resistance value, calculate the voltage dropped by each resistor.
- Supposing the battery has a voltage of 8 volts, and all resistors are  $1\text{ k}\Omega$  in resistance value, calculate the current passing through each resistor as well as the current passing through the battery.

[file i03815](#)

---

Question 7

Draw connecting wires that will create a *series* circuit with the three resistors and battery:

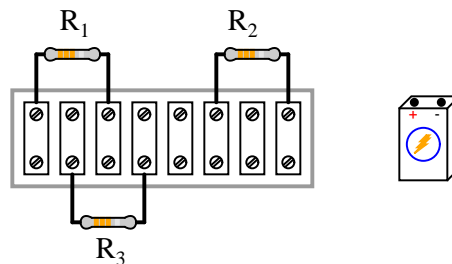

**Suggestions for Socratic discussion**

- Supposing the battery has a voltage of 15 volts, and all resistors are  $1\text{ k}\Omega$  in resistance value, calculate the voltage dropped by each resistor.
- Supposing the battery has a voltage of 15 volts, and all resistors are  $1\text{ k}\Omega$  in resistance value, calculate the current passing through each resistor as well as the current passing through the battery.

[file i03803](#)

---

Question 8

Draw connecting wires that will create a *parallel* circuit with the three resistors and battery:

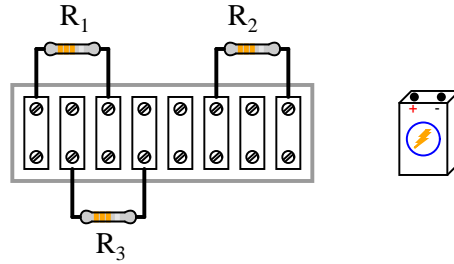

**Suggestions for Socratic discussion**

- Supposing the battery has a voltage of 12 volts, and all resistors are 1 k $\Omega$  in resistance value, calculate the voltage dropped by each resistor.
- Supposing the battery has a voltage of 12 volts, and all resistors are 1 k $\Omega$  in resistance value, calculate the current passing through each resistor as well as the current passing through the battery.

[file i03816](#)

---

Question 9

Draw connecting wires that will create a *series* circuit, such that current (conventional flow notation) will follow the directions shown by the arrows near each resistor:

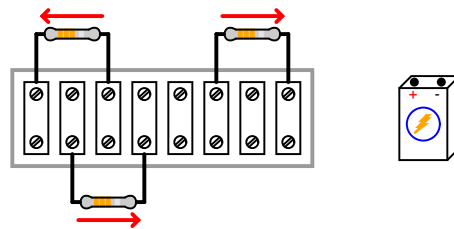

**Suggestions for Socratic discussion**

- Supposing the battery has a voltage of 10 volts, and all resistors are 1 k $\Omega$  in resistance value, calculate the voltage dropped by each resistor.
- Supposing the battery has a voltage of 10 volts, and all resistors are 1 k $\Omega$  in resistance value, calculate the current passing through each resistor as well as the current passing through the battery.

[file i03804](#)

---

Question 10

Draw connecting wires that will create a *parallel* circuit, such that current (conventional flow notation) will follow the directions shown by the arrows near each resistor:

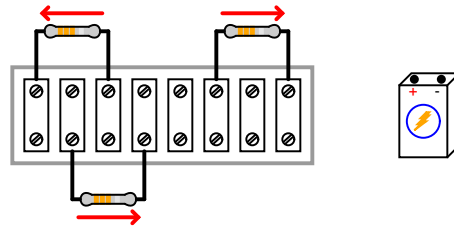

**Suggestions for Socratic discussion**

- Supposing the battery has a voltage of 7 volts, and all resistors are  $1\text{ k}\Omega$  in resistance value, calculate the voltage dropped by each resistor.
- Supposing the battery has a voltage of 7 volts, and all resistors are  $1\text{ k}\Omega$  in resistance value, calculate the current passing through each resistor as well as the current passing through the battery.

[file i03817](#)

---

Question 11

Draw connecting wires that will create a *series* circuit, such that voltage will drop across each resistor in the polarity shown by the (+) and (-) symbols:

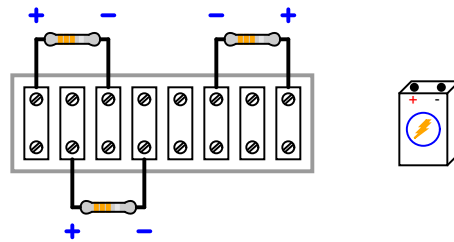

**Suggestions for Socratic discussion**

- Supposing the battery has a voltage of 1.5 volts, and all resistors are  $1\text{ k}\Omega$  in resistance value, calculate the voltage dropped by each resistor.
- Supposing the battery has a voltage of 1.5 volts, and all resistors are  $1\text{ k}\Omega$  in resistance value, calculate the current passing through each resistor as well as the current passing through the battery.

[file i03805](#)

---

Question 12

Draw connecting wires that will create a *parallel* circuit, such that voltage will drop across each resistor in the polarity shown by the (+) and (-) symbols:

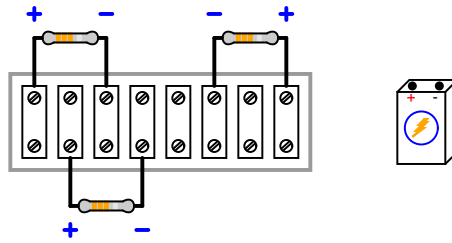

**Suggestions for Socratic discussion**

- Supposing the battery has a voltage of 1.5 volts, and all resistors are  $1\text{ k}\Omega$  in resistance value, calculate the voltage dropped by each resistor.
- Supposing the battery has a voltage of 1.5 volts, and all resistors are  $1\text{ k}\Omega$  in resistance value, calculate the current passing through each resistor as well as the current passing through the battery.

[file i03818](#)

---

Question 13

Resistors  $R_1$  and  $R_2$  are connected in parallel by virtue of being attached to the same two terminals on the terminal strip. Draw connecting wires that will create a *series* circuit between the parallel  $R_1/R_2$  pair and the lone resistor  $R_3$ , such that voltage will drop across each resistor in the polarity shown by the (+) and (-) symbols:

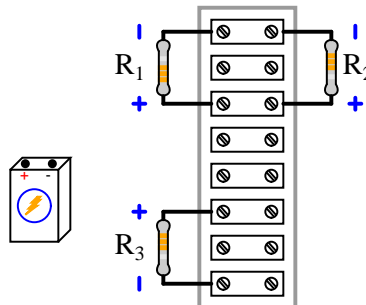

**Suggestions for Socratic discussion**

- Supposing the battery has a voltage of 11 volts, and all resistors are  $1\text{ k}\Omega$  in resistance value, calculate the voltage dropped by each resistor.
- Supposing the battery has a voltage of 11 volts, and all resistors are  $1\text{ k}\Omega$  in resistance value, calculate the current passing through each resistor as well as the current passing through the battery.

[file i03806](#)



---

Question 14

Draw connecting wires that will create a *parallel* circuit between all three resistors, such that current (conventional flow notation) will go through each resistor as shown by the arrows:

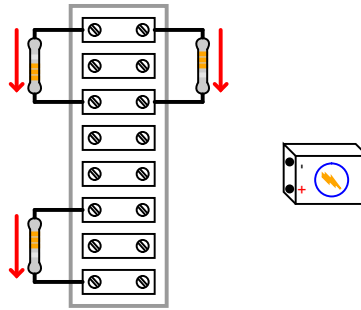

**Suggestions for Socratic discussion**

- Supposing the battery has a voltage of 14 volts, and all resistors are  $1\text{ k}\Omega$  in resistance value, calculate the voltage dropped by each resistor.
- Supposing the battery has a voltage of 14 volts, and all resistors are  $1\text{ k}\Omega$  in resistance value, calculate the current passing through each resistor as well as the current passing through the battery.

[file i03807](#)

---

Question 15

Draw connecting wires that will create a *series* circuit between all three resistors, such that current (conventional flow notation) will go through each resistor as shown by the arrows:

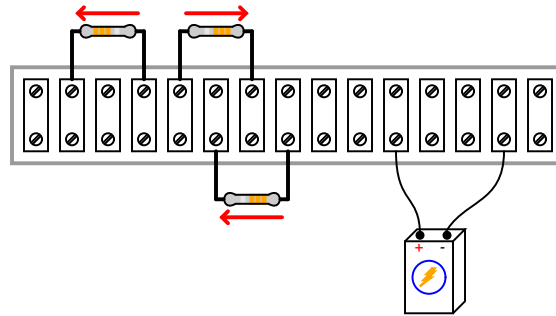

**Suggestions for Socratic discussion**

- Supposing the battery has a voltage of 18 volts, and all resistors are  $1\text{ k}\Omega$  in resistance value, calculate the voltage dropped by each resistor.
- Supposing the battery has a voltage of 18 volts, and all resistors are  $1\text{ k}\Omega$  in resistance value, calculate the current passing through each resistor as well as the current passing through the battery.

[file i03819](#)

---

Question 16

Draw connecting wires that will create a *parallel* circuit, such that voltage will drop across each resistor in the polarity shown by the (+) and (-) symbols:

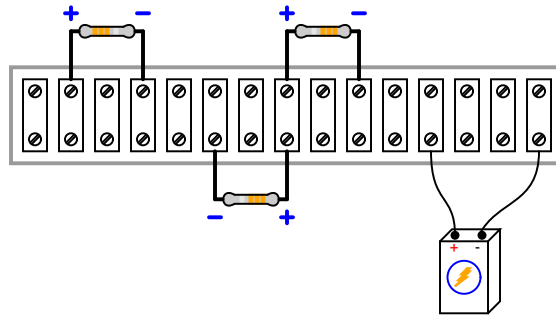

**Suggestions for Socratic discussion**

- Supposing the battery has a voltage of 2 volts, and all resistors are  $1\text{ k}\Omega$  in resistance value, calculate the voltage dropped by each resistor.
- Supposing the battery has a voltage of 2 volts, and all resistors are  $1\text{ k}\Omega$  in resistance value, calculate the current passing through each resistor as well as the current passing through the battery.

[file i03820](#)

---

Question 17

Draw connecting wires that will create a *series-parallel* circuit, such that the voltage dropped across  $R_1$  will be twice as much as the voltage dropped across  $R_2$  or  $R_3$ . Make sure each resistor drops voltage in the polarity shown by the (+) and (-) symbols:

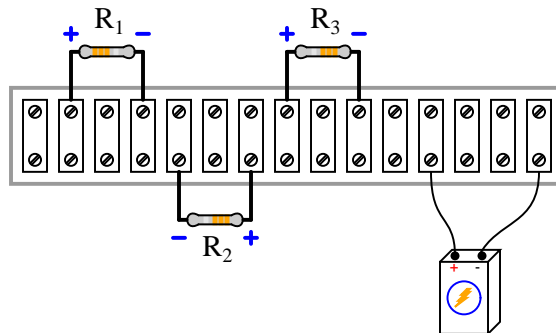

- Supposing the battery has a voltage of 12 volts, and all resistors are  $1\text{ k}\Omega$  in resistance value, calculate the voltage dropped by each resistor.
- Supposing the battery has a voltage of 12 volts, and all resistors are  $1\text{ k}\Omega$  in resistance value, calculate the current passing through each resistor as well as the current passing through the battery.

[file i03561](#)

---

Question 18

Draw connecting wires that will create a *series-parallel* circuit, such that the voltage dropped across  $R_1$  will be twice as much as the voltage dropped across  $R_2$  or  $R_3$ . Make sure each resistor passes current (conventional flow notation) in the directions as shown by the arrows:

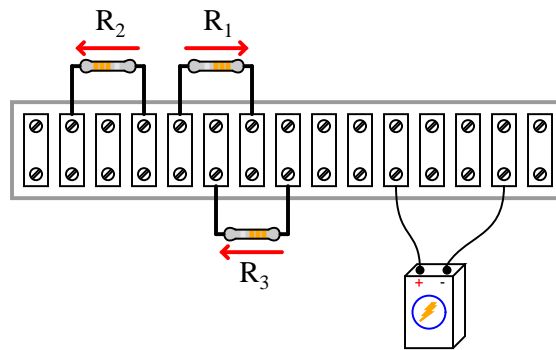

- Supposing the battery has a voltage of 18 volts, and all resistors are  $1\text{ k}\Omega$  in resistance value, calculate the voltage dropped by each resistor.
- Supposing the battery has a voltage of 18 volts, and all resistors are  $1\text{ k}\Omega$  in resistance value, calculate the current passing through each resistor as well as the current passing through the battery.

[file i03562](#)

---

Question 19

Suppose we needed to connect a resistor in series with a sensitive analog meter movement to range that meter for a certain maximum voltage, and we were going to make all connections using a terminal strip. Draw connecting wires that will create a *series* circuit between the meter and the resistor, such that polarity of the applied voltage will be correct for the meter with the red test lead being positive and the black test lead being negative:

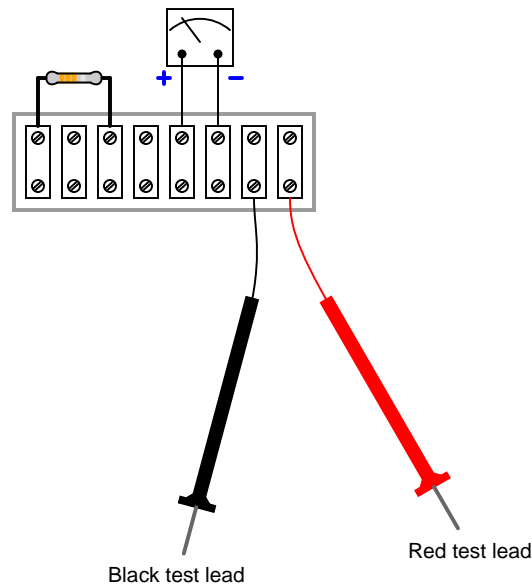

[file i03808](#)

Question 20

Suppose we needed to connect a variable resistor in series with a sensitive analog meter movement to range that meter for a certain maximum voltage, and we were going to make all connections using a terminal strip. Draw connecting wires that will create a *series* circuit between the meter and two terminals of the potentiometer, such that polarity of the applied voltage will be correct for the meter with the red test lead being positive and the black test lead being negative:

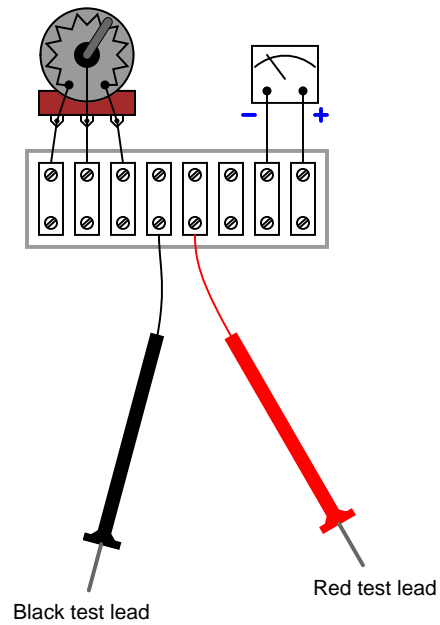

file i03809

Question 21

Determine whether moving the potentiometer knob *clockwise* will increase or decrease the sensitivity of this analog voltmeter:

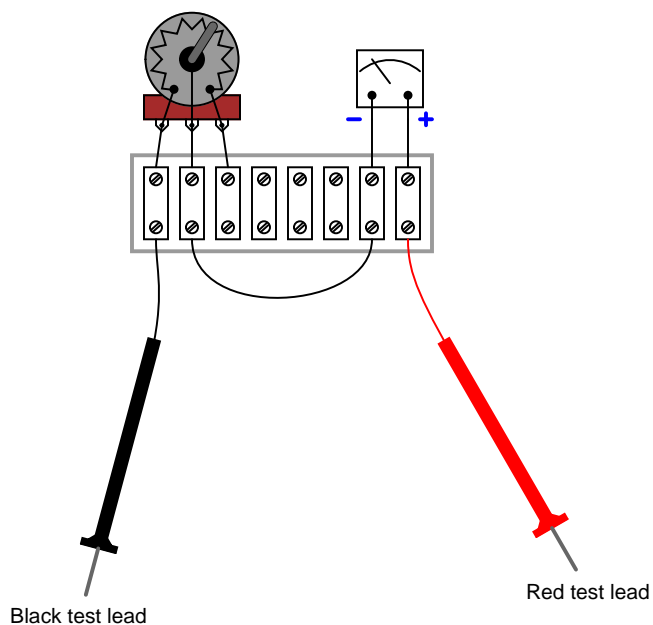

**Suggestions for Socratic discussion**

- Which way would we need to turn the potentiometer in order to make the voltmeter have a higher range (i.e. full-scale deflection represents a greater measured voltage value than before)

[file i03810](#)

---

Question 22

Sketch connecting wires such that the relay will energize when the normally-open (NO) pushbutton switch is pressed. Be sure to wire the relay in such a way that current (conventional flow) follows the directions indicated by the arrows:

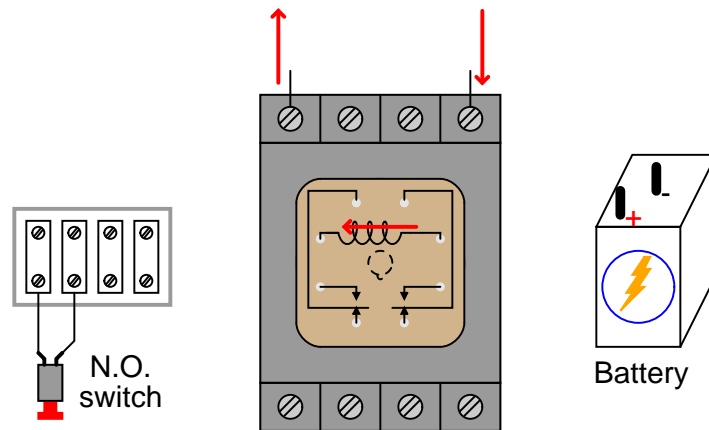

file i03830

---

Question 23

Sketch connecting wires such that the relay will energize when the normally-open (NO) pushbutton switch is pressed. Be sure to wire the relay in such a way that voltage will appear in the polarities shown by the (+) and (-) marks:

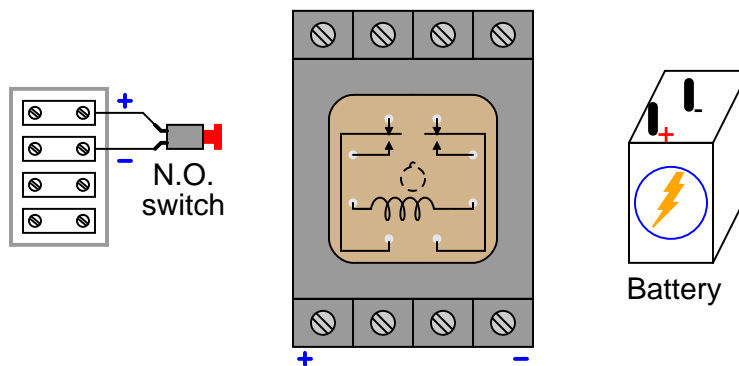

file i03831

Question 24

Sketch connecting wires such that the relay will energize and turn on the lamp when the normally-open (NO) pushbutton switch is pressed. Use the following schematic diagram as a guide:

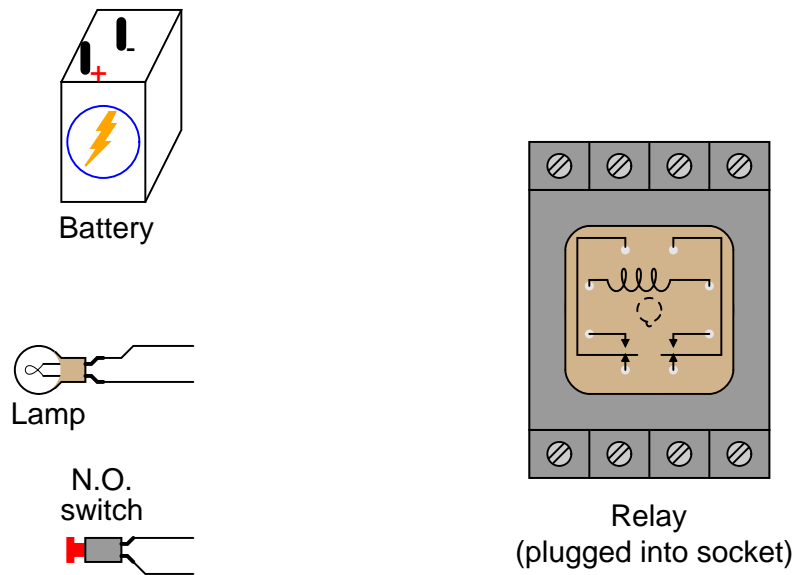

Schematic diagram

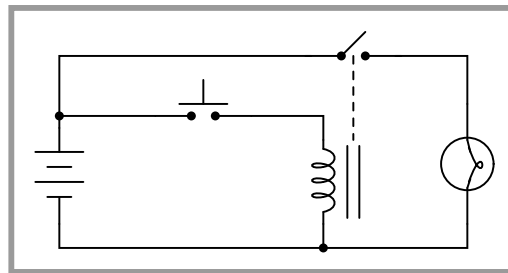

Note how the relay coil and lamp are separate (parallel) branches in this circuit. The pushbutton switch *only* carries coil current, while the relay's switch contact *only* carries lamp current.

**Suggestions for Socratic discussion**

- Suppose the battery is rated at 12 volts, the lamp has a “hot” filament resistance of 3.2 ohms, and the relay coil has a wire resistance of 240 ohms. Calculate the amount of current carried by the switch when it is pressed.

[file i03835](#)

Question 25

Sketch connecting wires such that the relay will energize and turn on the lamp when the normally-open (NO) pushbutton switch is pressed. Be sure to wire the relay in such a way that current (conventional flow) follows the directions indicated by the arrows, and that the switch only carries relay coil current (no lamp current in addition to coil current):

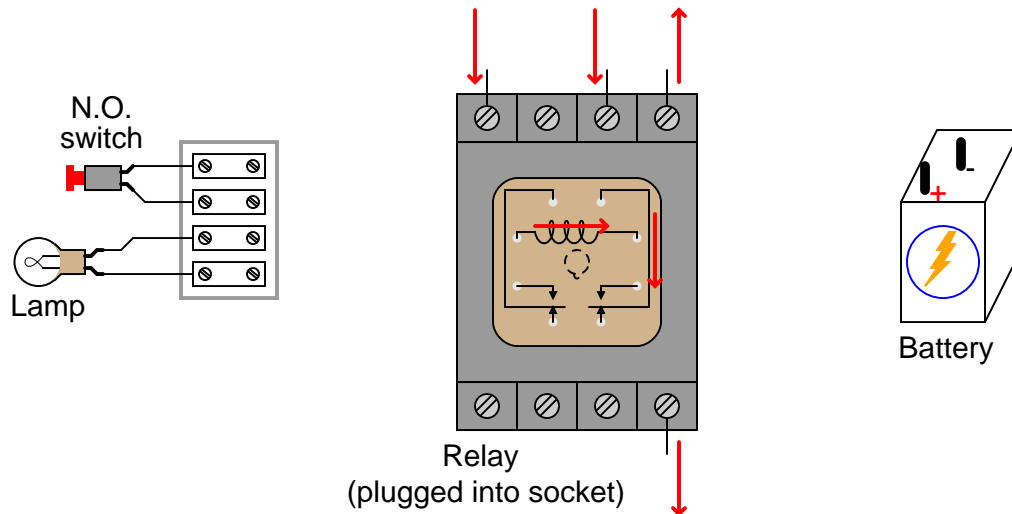

[file i03829](#)

Question 26

Sketch connecting wires such that the relay will energize and turn the lamp *off* when the normally-open (NO) pushbutton switch is pressed (i.e. the lamp should be *on* when the pushbutton switch is not being pressed). Be sure to wire the relay in such a way that current (conventional flow) follows the directions indicated by the arrows, and that the switch only carries relay coil current (no lamp current in addition to coil current):

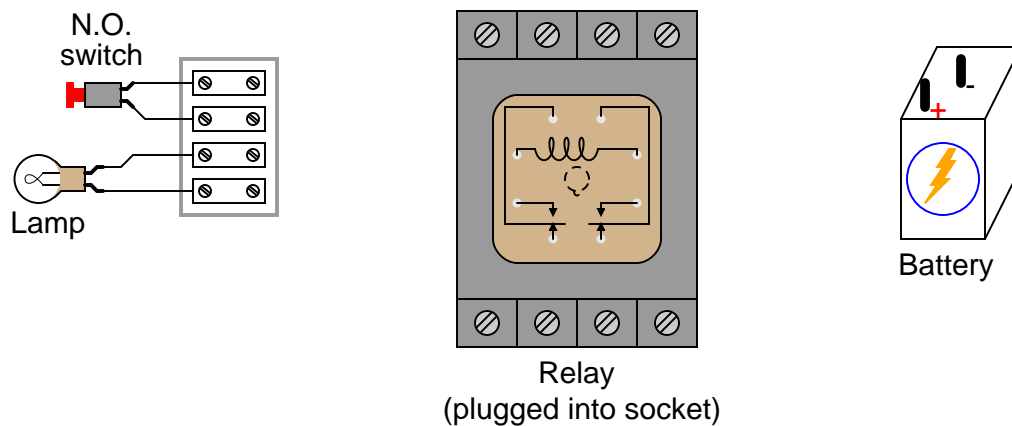

[file i03832](#)



Question 27

Sketch connecting wires such that the relay will select one of two different thermocouples to send millivoltage signals to a temperature indicator. Use the following schematic diagram as a guide:

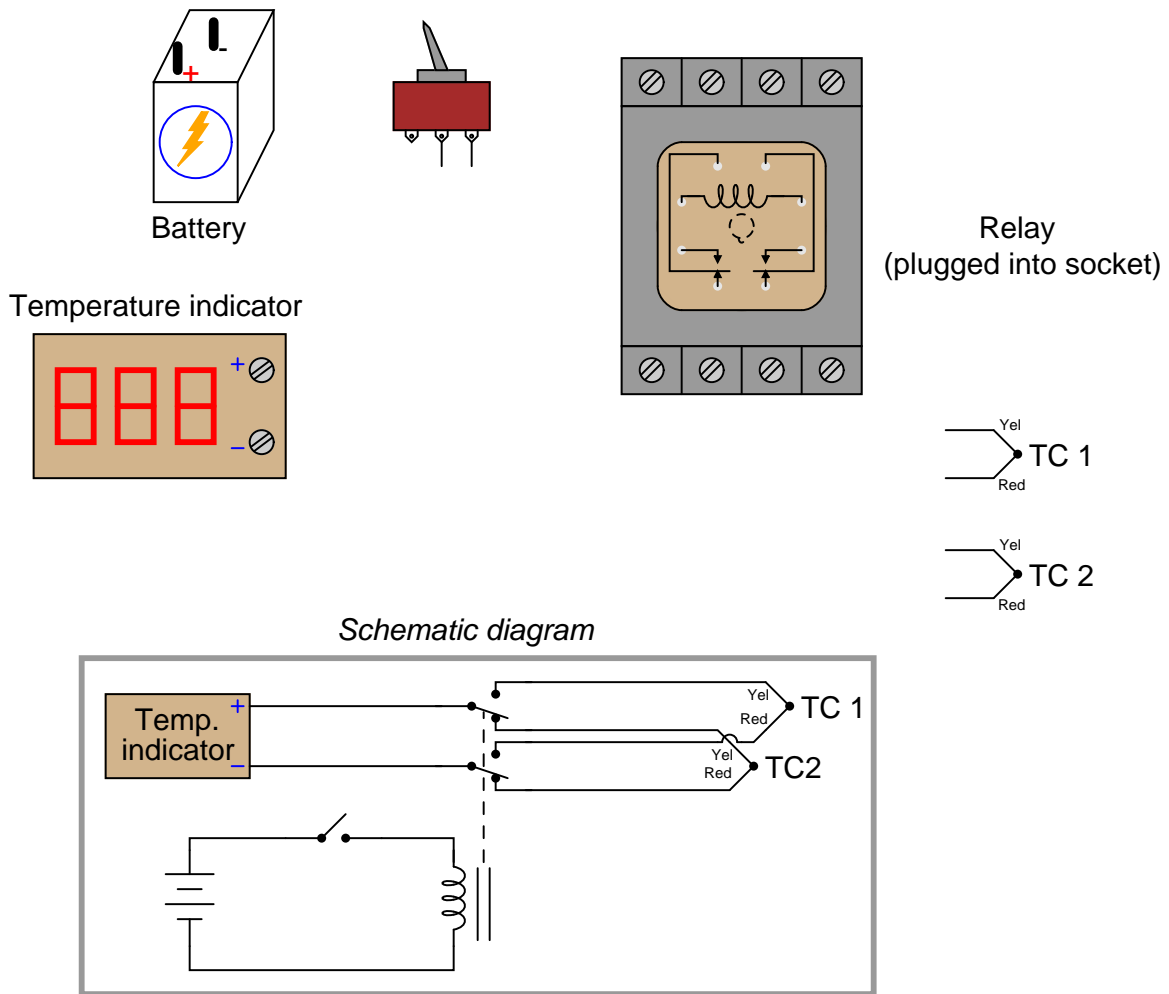

[file i04588](#)

Question 28

Draw connecting wires that will create a *series* circuit, such that the loop-powered pressure transmitter will drive the ammeter to indicate pressure:

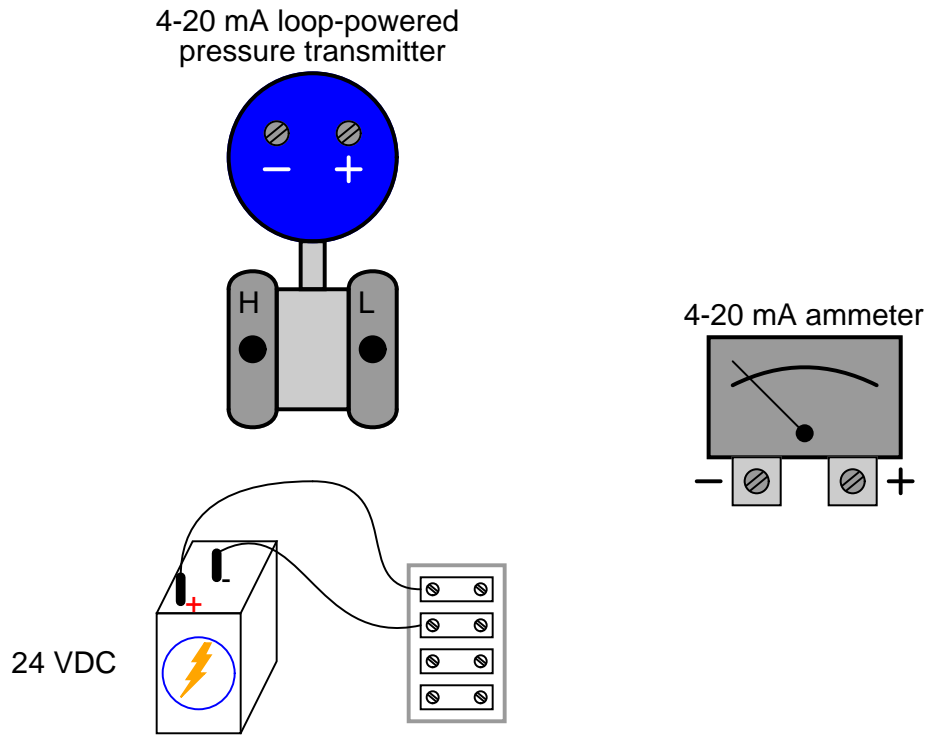

file i03812

Question 29

Draw connecting wires that will create a *series* circuit, such that the loop-powered pressure transmitter will drive both ammeters to indicate pressure:

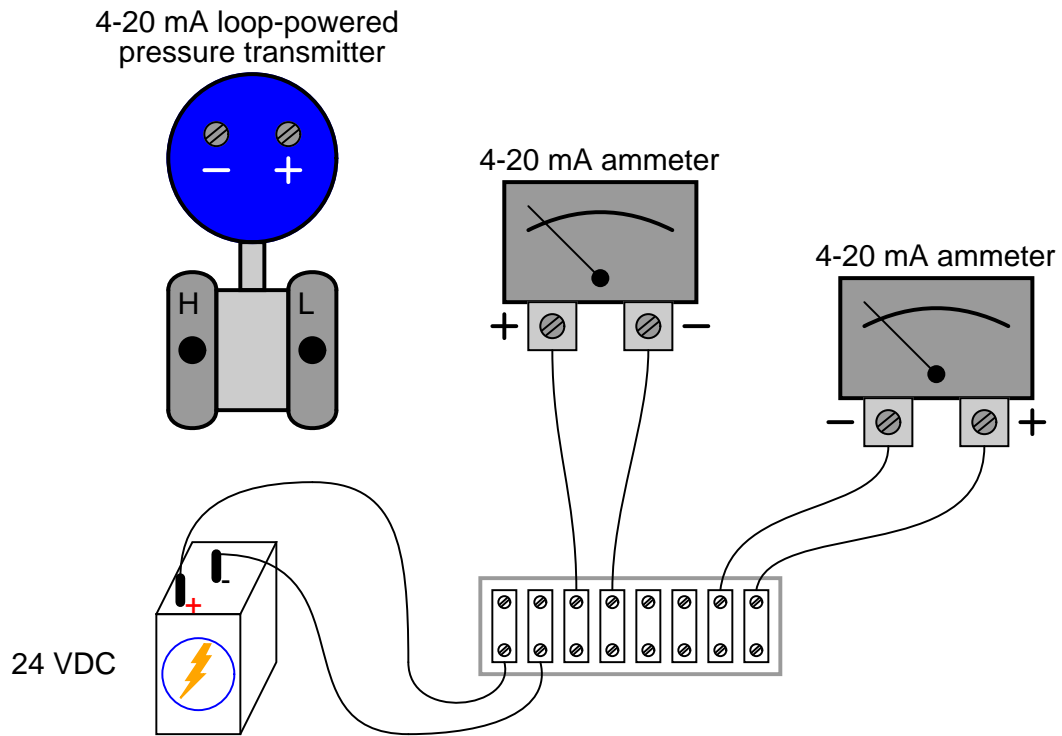

file i03821

Question 30

Some models of the “MicroLogix” series of programmable logic controller (PLC) manufactured by Allen-Bradley come equipped with analog inputs, designed to receive either voltage or current signals from analog sensors. Examine the internal resistances of the analog inputs (IA/0, IA/1, IA/2, and IA/3) to determine which are designed to input voltage signals and which are designed to input current signals.

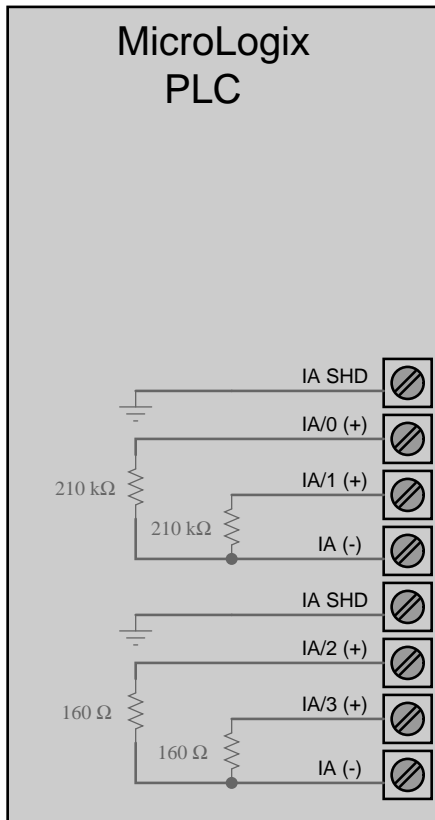

Sensor with current output

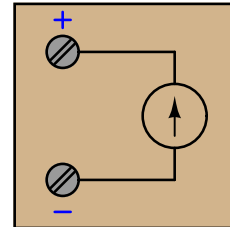

Sensor with voltage output

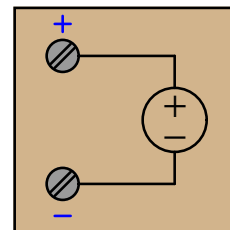

Sensor with current output

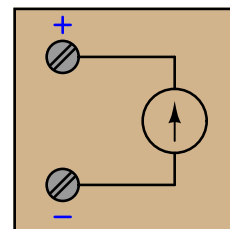

Hint: think in terms of the input resistances of *voltmeters* and *ammeters*. Which of these test instrument types are known for having very large input resistance values? Which of these test instrument types are known for having very small input resistance values?

Assuming the three sensors shown all have internal power sources (no need for an external DC power supply to make them output their respective signals), draw connecting wires between these sensors and the appropriate inputs on the PLC.

[file i03811](#)

Question 31

Draw connecting wires between the 4-20 mA loop-powered pressure transmitter, the 24 VDC power supply, and the “PV input” of the Honeywell controller so that the controller registers the measured pressure as its process variable (PV):

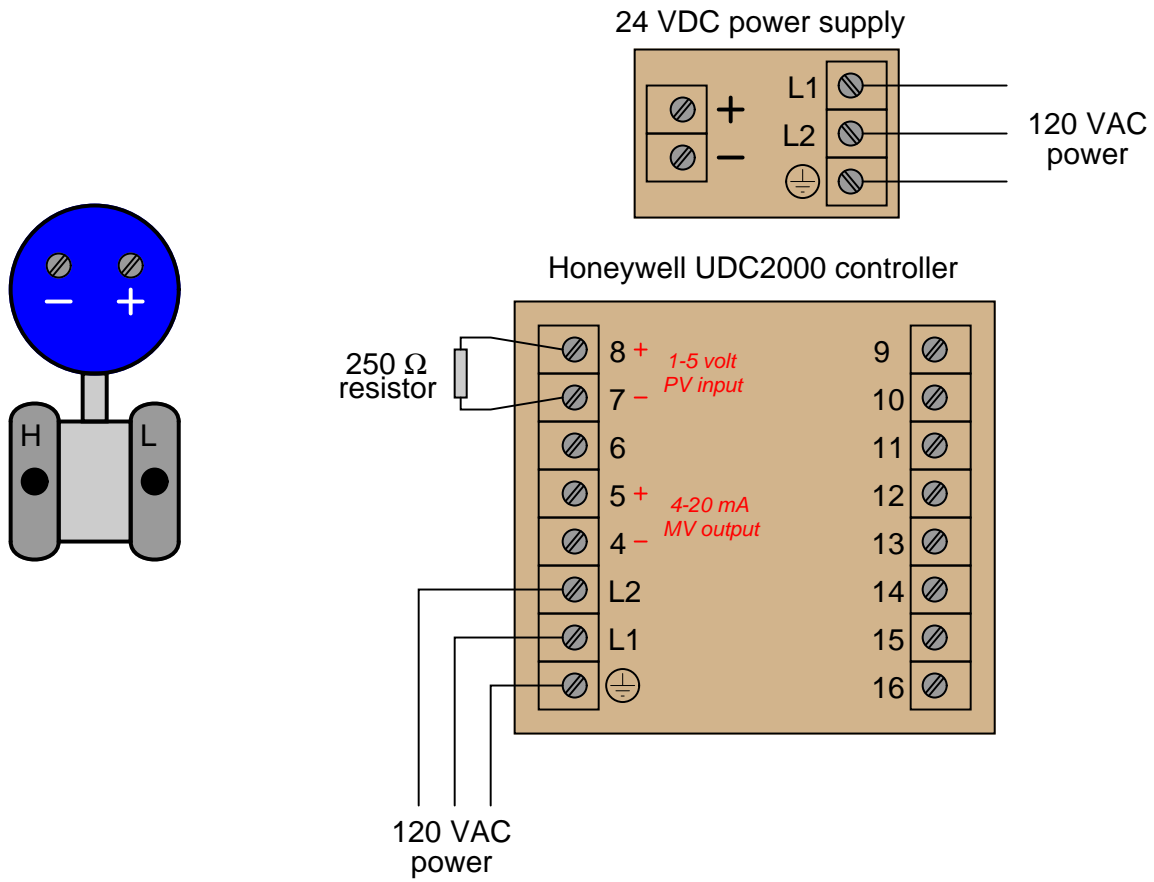

[file i03833](#)

Question 32

Draw connecting wires between the 4-20 mA loop-powered pressure transmitter, the 24 VDC power supply, and “Analog input #1” of the Honeywell UDC2500 controller so that the controller registers the measured pressure as its process variable (PV):

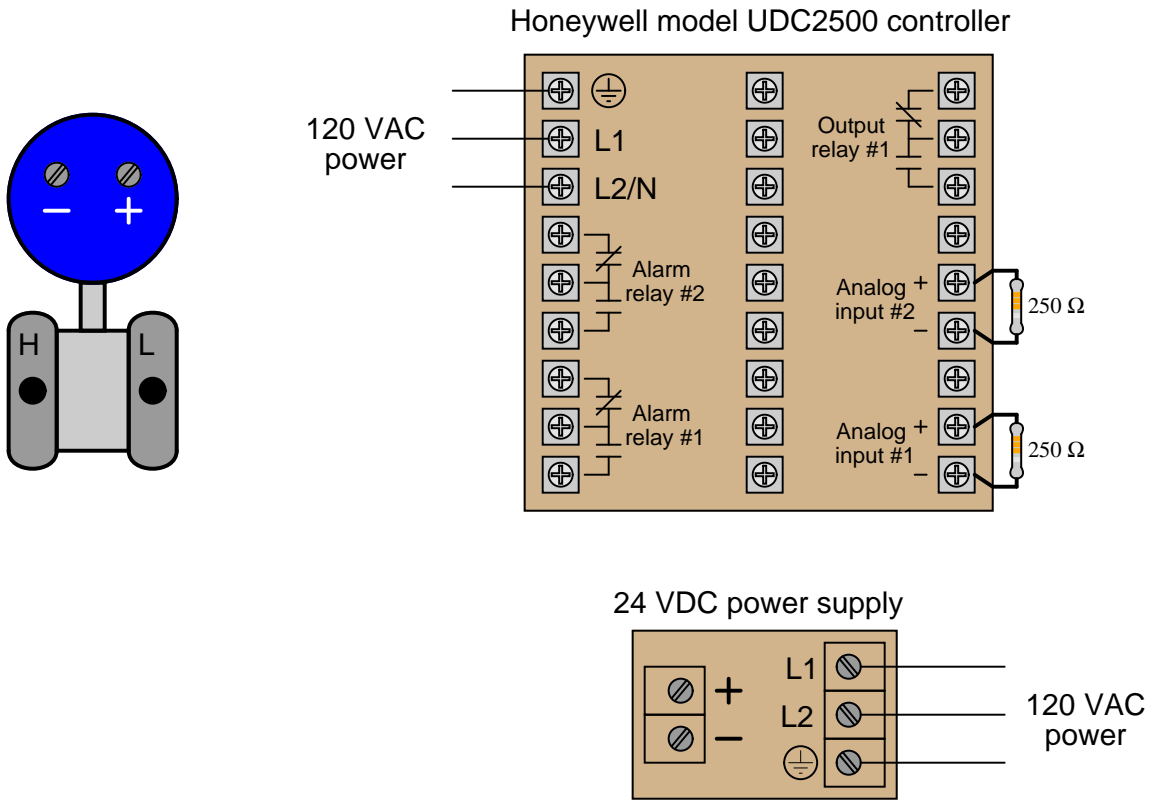

[file i01118](#)

Question 33

Draw connecting wires between the 4-20 mA *self-powered* (4-wire) level transmitter, the 24 VDC power supply, and “Analog input #1” of the Honeywell UDC2500 controller so that the controller registers the measured level as its process variable (PV). Assume the 4-wire transmitter’s analog output is the *sourcing* type:

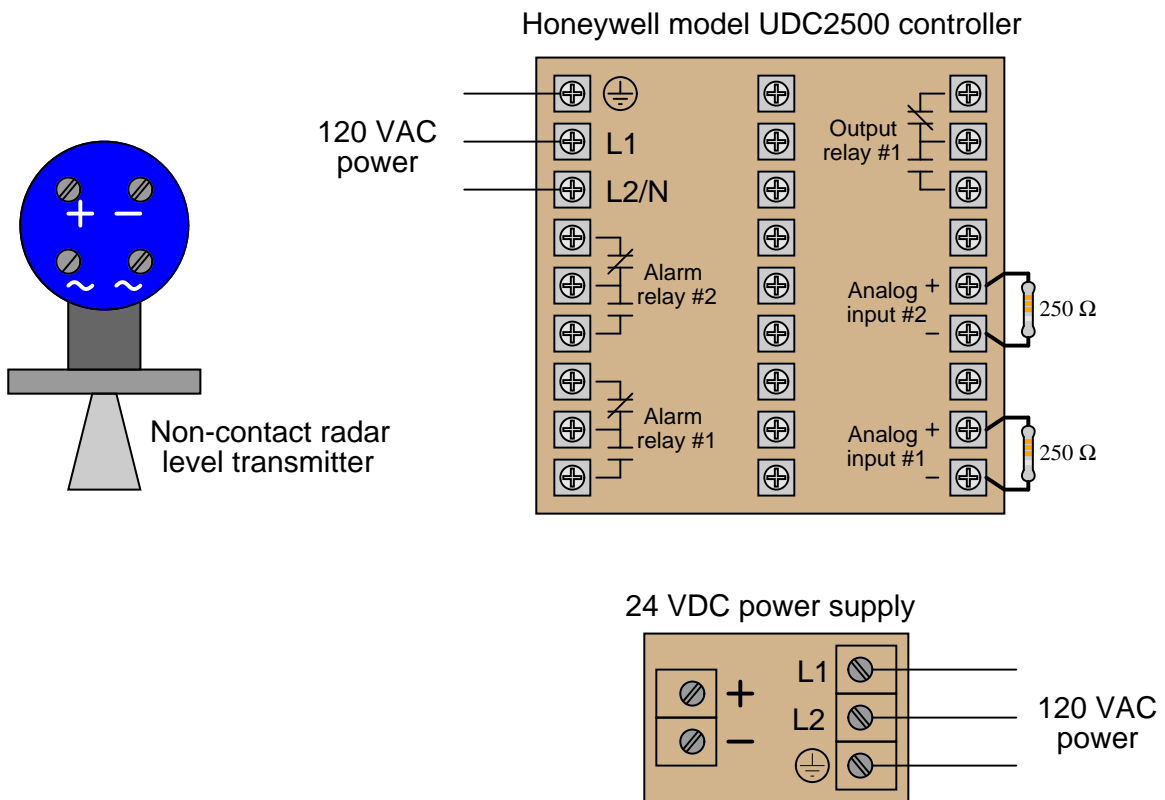

[file i01119](#)

---

Question 34

Sketch connecting wires to allow this data acquisition unit (DAQ) to sense the voltage produced by the solar cell, on input channel #2:

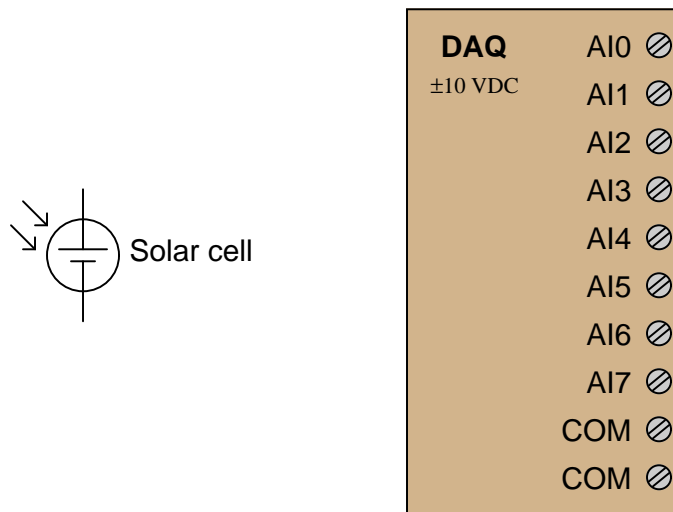

Your circuit should be wired in such a way that greater light intensity falling on the cell produces a more *positive* signal measured by the DAQ.

[file i04581](#)

---

Question 35

Sketch connecting wires so that this DAQ unit will register an increasing positive voltage on channel 2 as the potentiometer shaft is turned *clockwise*:

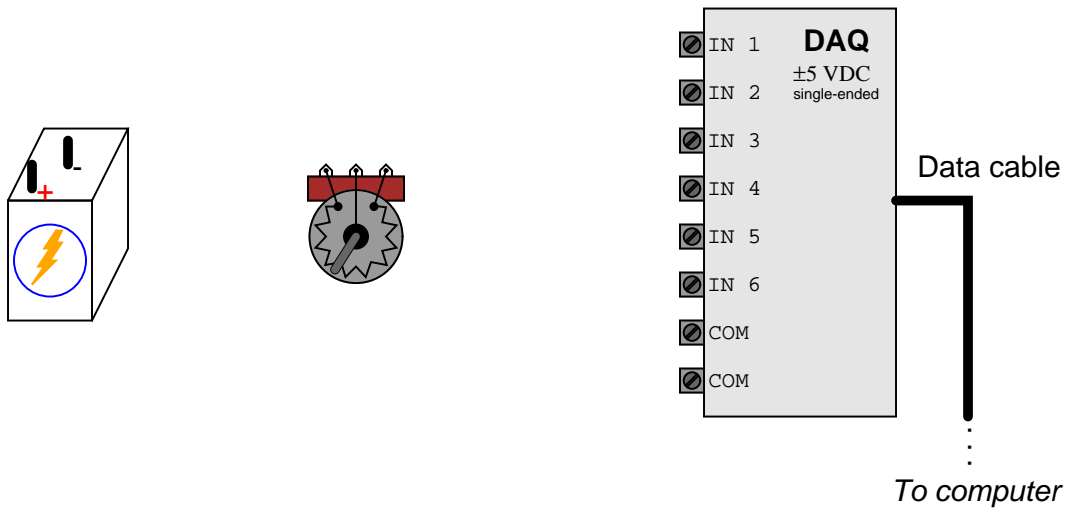

[file i02124](#)



Question 36

Sketch connecting wires so that this DAQ unit will register an increasing positive voltage on channel 5 as the potentiometer wiper moves to the *left*:

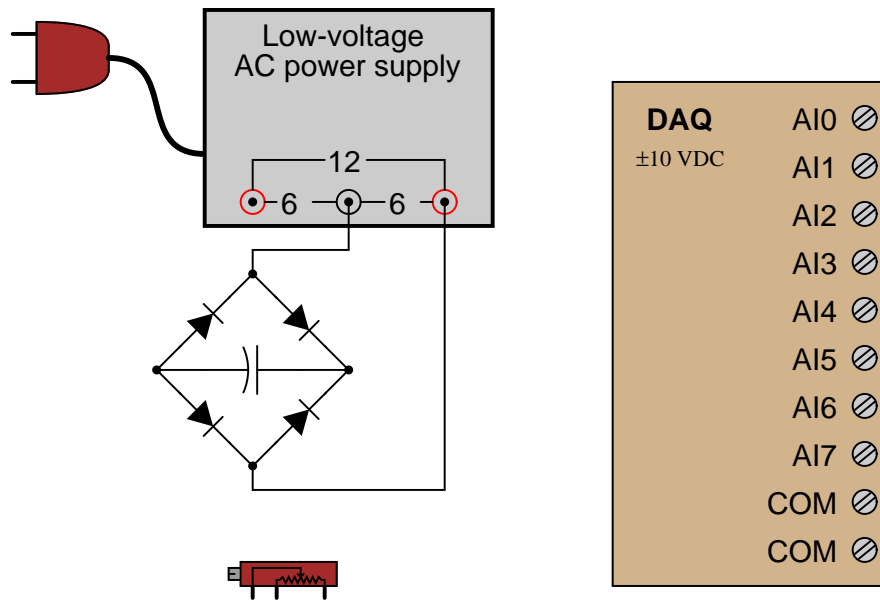

[file i02126](#)

Question 37

Sketch connecting wires so that this DAQ unit will register an increasing negative voltage on channel 1 as the potentiometer shaft is turned *clockwise*:

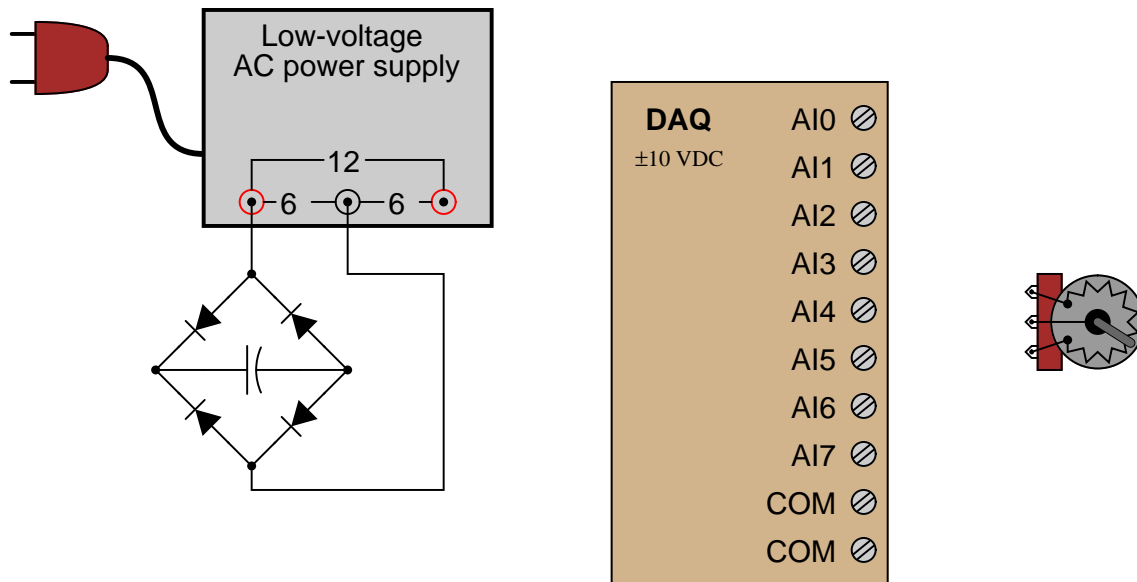

[file i02127](#)

Question 38

Determine how to connect this DAQ unit to measure the output voltage of the Wheatstone bridge in such a way that an increasing compression on the strain gauge causes a *positive* indication at channel 3 of the DAQ, and that the same DAQ channel will register zero when the strain gauge is at rest:

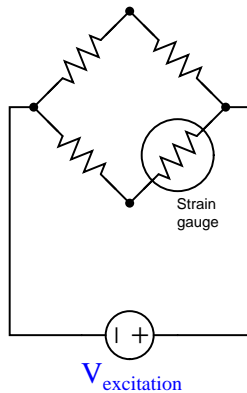

<input type="checkbox"/>	AI0+	<b>DAQ</b> ±10 VDC differential
<input type="checkbox"/>	AI0-	
<input type="checkbox"/>	AI1+	
<input type="checkbox"/>	AI1-	
<input type="checkbox"/>	AI2+	
<input type="checkbox"/>	AI2-	
<input type="checkbox"/>	AI3+	
<input type="checkbox"/>	AI3-	
<input type="checkbox"/>	AI Gnd	
<input type="checkbox"/>	Shield	

[file i02121](#)

Question 39

Sketch connecting wires to allow this data acquisition unit (DAQ) to sense strain using quarter-bridge strain gauge circuits on input channels #0 and #3, such that increasing tension on the strain gauge (increasing gauge resistance) generates a more *positive* signal voltage on each channel:

<b>DAQ</b> ±10 VDC differential	<input type="checkbox"/>	AI0+
	<input type="checkbox"/>	AI0-
	<input type="checkbox"/>	AI1+
	<input type="checkbox"/>	AI1-
	<input type="checkbox"/>	AI2+
	<input type="checkbox"/>	AI2-
	<input type="checkbox"/>	AI3+
	<input type="checkbox"/>	AI3-
	<input type="checkbox"/>	Shield
	<input type="checkbox"/>	AI Gnd

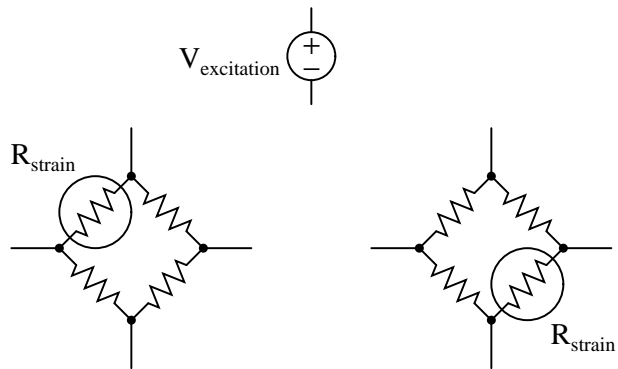

[file i04585](#)

Question 40

Suppose we wished to use this DAQ unit to measure the *peak inverse voltage* across diode  $D_3$  during operation of the power supply circuit. Identify how we should connect channel 1 of the DAQ to do this, assuming we want the DAQ to register a *positive* value at the moment in time of the diode's peak inverse voltage:

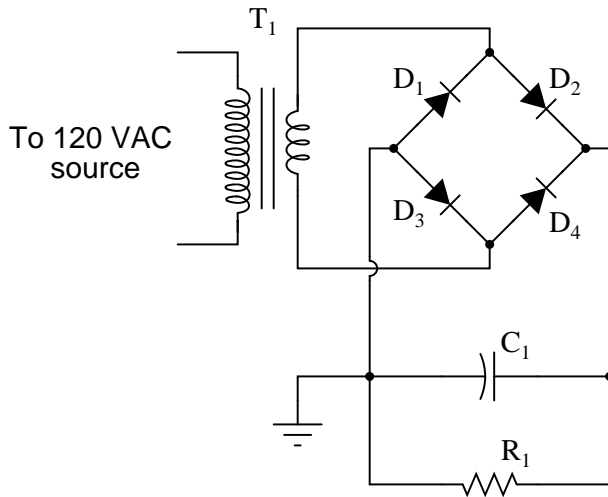

	DAQ
<input type="radio"/> AI0+	±10 VDC differential
<input type="radio"/> AI0-	
<input type="radio"/> AI1+	
<input type="radio"/> AI1-	
<input type="radio"/> AI2+	
<input type="radio"/> AI2-	
<input type="radio"/> AI3+	
<input type="radio"/> AI3-	
<input type="radio"/> AI Gnd	
<input type="radio"/> Shield	

[file i02120](#)

Question 41

Identify suitable input terminals, proper modes, and necessary connecting wires to allow this National Instruments E-series data acquisition unit (DAQ) to sense the two voltage sources shown:

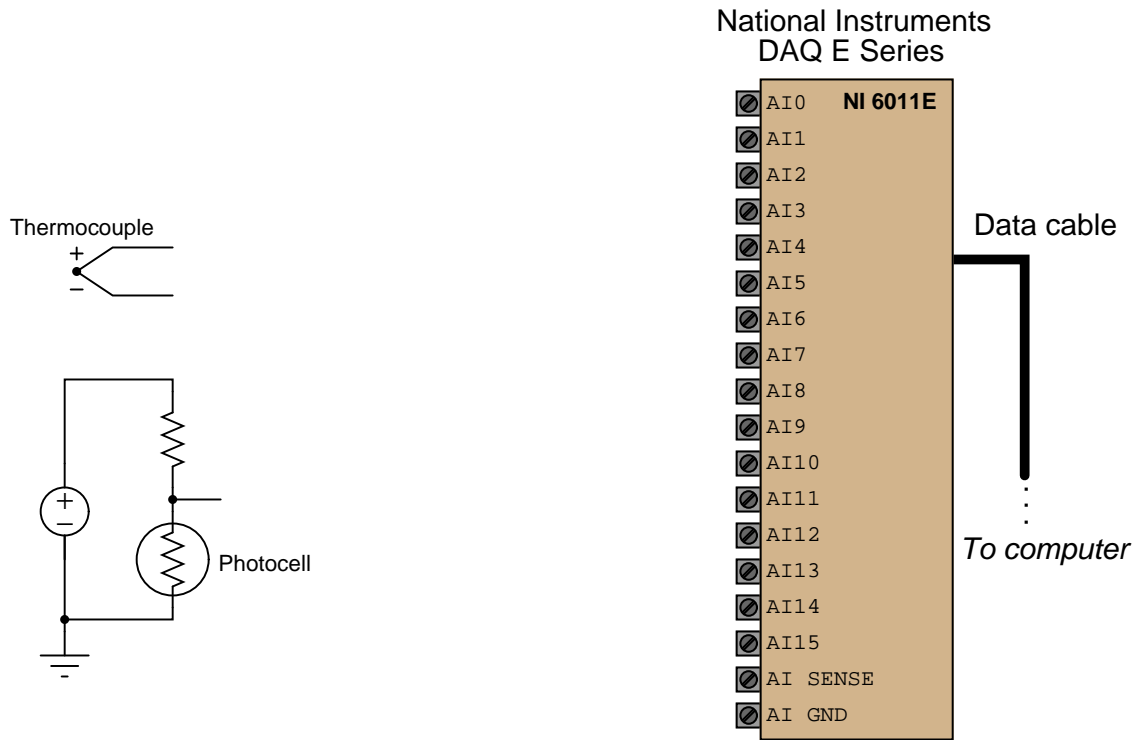

The available modes for the input channels are RSE, NRSE, and DIFF:

Channel	Mode	First terminal	Second terminal
0			
1			

---

Question 42

Here, a temperature sensor called an *RTD* is used to translate ambient temperature into a proportional resistance. This in turn is converted into a proportional voltage signal by a constant current fed through the RTD by the current source:

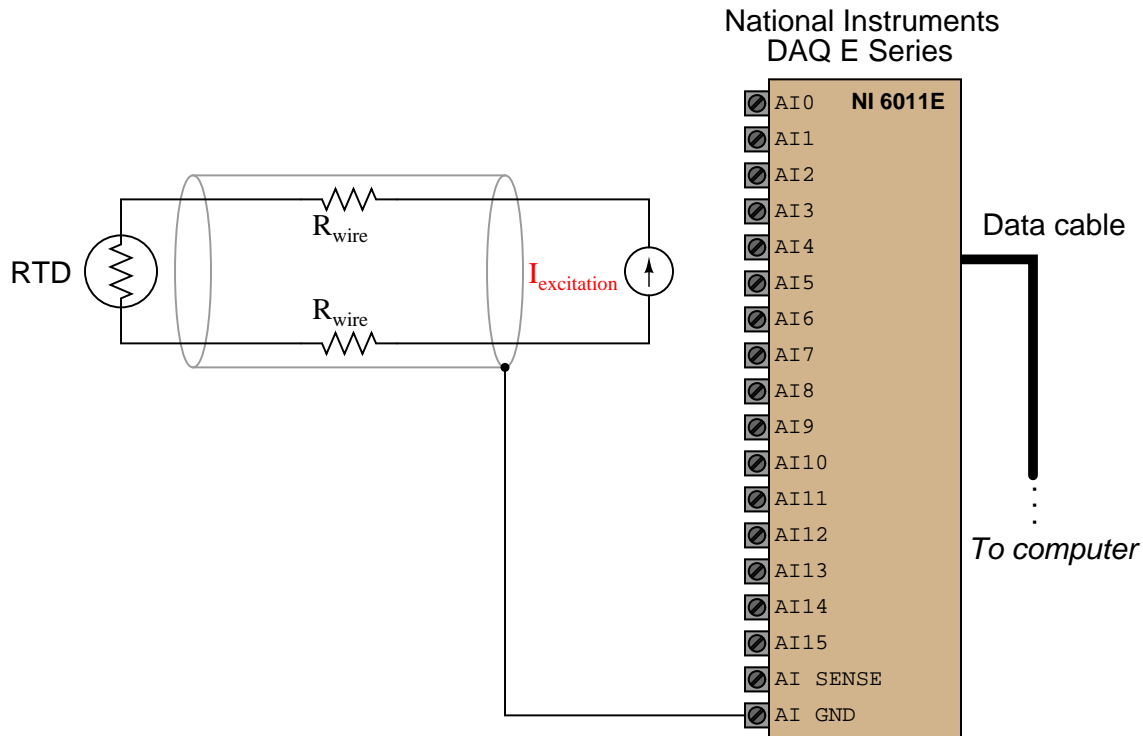

Determine how to connect the first analog input channel this DAQ to measure the RTD's voltage drop, but in such a way that voltage dropped along the cable's length will not affect the measurement. Also, determine whether this DAQ should be configured for *single-ended* or *differential* input  
[file i02122](#)

---

Question 43

Sketch a diagram showing all wire and tube connections between a primary sensing element, transmitter, controller, and/or final control element for an hypothetical control system. The instrument models will be randomly selected by your instructor, so that no two students will have the same combination of instruments. Your task is to locate the appropriate datasheets or manuals in the Instrumentation Reference (or online) to identify the proper wire terminals to connect, then sketch a simple loop diagram showing how the appropriate terminals on each device connect to terminals on the other devices to make a functional instrument loop. For instruments with multiple data channels, the instructor will also select which channel(s) to use for your loop (e.g. a PLC analog input card with 16 channels, the instructor may select channel #5).

The instructor will assess the accuracy of your diagram when you present it along with documentation from the manufacturer showing how you identified each device's terminals and connections. Fidelity to the manufacturer's documentation is the only criterion for passing this mastery assessment.

The following lists recommend component types and models for the instructor to choose (randomly selecting one instrument from each list as applicable):

### Primary Sensing Element / Switch options

- Discrete
  - Mechanical limit switch with form-C contacts
  - Mechanical process switch with form-C contacts
  - Inductive proximity switch, sourcing
  - Inductive proximity switch, sinking
- Pressure
  - Gauge pressure with single-block and bleed valves
  - Gauge pressure with double-block and bleed valves
  - Differential pressure with 3-valve manifold
  - Differential pressure with 5-valve manifold
- Level
  - Rosemount 2120 vibrating fork level switch with relay output
  - Rosemount 2120 vibrating fork level switch with PNP output
- Temperature
  - Thermocouple
  - 2-wire RTD
  - 3-wire RTD
  - 4-wire RTD
- Flow
  - Orifice plate with isolation valves
  - Turbine with pick-off coil
- Analytical
  - Glass pH probe
  - Conductivity probe

### Analog output transmitter options

- Pressure
  - Rosemount 1151 Alphaline (analog)
  - Rosemount 1151 HART (digital)
  - Rosemount 3051 HART (digital)
  - Yokogawa DPharp EJX110A
  - Yokogawa DPharp EJX910
  - Honeywell ST3000
- Level
  - Rosemount APEX non-contact radar
  - Rosemount 3300 guided-wave radar
  - Rosemount 5300 guided-wave radar
- Temperature
  - Rosemount 444
  - Rosemount 644
  - Rosemount 3044
  - Rosemount 3144
  - Foxboro RTT15
  - Foxboro RTT30
  - Moore Industries SPT with sourcing (4-wire) 4-20 mA output
  - Moore Industries SPT with sinking (2-wire) 4-20 mA output
  - Moore Industries TRX
  - Moore Industries TDY
- Flow
  - Foxboro CFT50 coriolis
- Analytical
  - Rosemount 5081-P (pH)
  - Daniel 700 gas chromatograph (4 analog output channels)
  - Foxboro 876PH (pH/ORP/ISE)

### Controller options – single-loop and DCS

- Siemens 352P single-loop
- Siemens 353 four-loop
- Siemens 353R multi-loop
  - Input module: IO-4TC (4-channel analog thermocouple)
  - Input module: IO-4RT (4-channel analog RTD)
  - Input module: IO-8AI-2 (8-channel analog current)
  - Input module: IO-8AI-V (8-channel analog voltage)
  - Input module: IO-8DI24DMN (8-channel discrete DC)
  - Input module: IO-8DI24DSI (8-channel discrete DC)
  - Input module: IO-8DI115AMN (8-channel discrete AC)
  - Input module: IO-8DI115ASI (8-channel discrete AC)
  - Output module: IO-8AO (8-channel analog current)
  - Output module: IO-8DO60DMN (8-channel discrete DC)
  - Output module: IO-8DO60DEI (8-channel discrete DC)
- Foxboro 762CNA dual-loop
- Foxboro 716C single-loop
- Foxboro 718TC single-loop
- Moore Industries 535 single-loop
- Honeywell UDC2300 single-loop
- Honeywell UDC3500 single-loop
- Emerson ROC800 SCADA/RTU
  - AI-12 analog input module
  - RTD input module
  - AO analog output module
- Emerson DeltaV DCS with M-series I/O cards
  - Input module: M Series 2, DI 8-channel 24 VDC dry contact
  - Input module: M Series 2, DI 8-channel 24 VDC isolated
  - Input module: M Series 2, DI 8-channel 120 VAC dry contact
  - Input module: M Series 2, DI 8-channel 120 VAC isolated
  - Input module: M Series 2, AI 8-channel 4-20 mA
  - Input module: M Series 2, AI 8-channel 1-5 VDC
  - Input module: M Series 2, AI RTD, ohms
  - Input module: M Series 2, AI thermocouple, mV
  - Output module: M Series 2, DO 8-channel 24 VDC, high-side
  - Output module: M Series 2, DO 8-channel 24 VDC, isolated
  - Output module: M Series 2, DO 8-channel 120/230 VAC, high-side
  - Output module: M Series 2, DO 8-channel 120/230 VAC, isolated
  - Output module: M Series 2, AO 8-channel 4-20 mA
- Honeywell Experion DCS with 2MLF-series I/O cards
  - Input module: 2MLF-AC8A, 8-channel 4-20 mA
  - Input module: 2MLF-AV8A, 8-channel 0-10 volt
  - Input module: 2MLF-RD4A, 4-channel RTD
  - Output module: 2MLF-DC4A, 4-channel 4-20 mA



### **Controller options – PLC**

- Automation Direct “CLICK” I/O cards
  - Input module: C0-08ND3 (8-channel DC)
  - Input module: C0-08NE3 (8-channel AC/DC)
  - Input module: C0-08NA (8-channel AC)
  - Output module: C0-08TD1 (8-channel DC sinking)
  - Output module: C0-08TD2 (8-channel DC sourcing)
  - Output module: C0-08TA (8-channel AC)
  - Output module: C0-04TRS (4-channel relay)
- Siemens S7-300 I/O cards
  - Input module: DI 32 x AC 120 V (6ES7321-1EL00-0AA0)
  - Input module: DI 32 x DC 24 V (6ES7321-1BL00-0AA0)
  - Input module: DI 16 x DC 24 V (6ES7321-1BH50-0AA0)
  - Input module: DI 16 x DC 48-125 V (6ES7321-1CH20-0AA0)
  - Input module: AI 8 x 16 bit (6ES7331-7NF00-0AB0)
  - Output module: DO 32 x AC 120/230 V/1A (6ES7322-1FL00-0AA0)
  - Output module: DO 16 x DC 24 V/0.5A (6ES7322-1BH01-0AA0)
  - Output module: DO 16 x Rel (6ES7322-1HH01-0AA0)
  - Output module: AO 8 x 12 bit (6ES7332-5HF00-0AB0)
- Rockwell (Allen-Bradley) ControlLogix 5000 I/O cards
  - Input module: 1756-IA16 (16-channel discrete 120 VAC)
  - Input module: 1756-IB16 (16-channel discrete 24 VDC)
  - Input module: 1756-IF6CIS (6-channel analog current)
  - Input module: 1756-IF6I (6-channel analog isolated voltage/current)
  - Input module: 1756-IF8 (8-channel analog differential voltage/current)
  - Input module: 1756-IR6I (6-channel analog RTD)
  - Input module: 1756-IT6I (6-channel analog thermocouple)
  - Output module: 1756-OA8 (8-channel discrete 120 VAC)
  - Output module: 1756-OB8 (8-channel discrete 24 VDC)
  - Output module: 1756-OW16I (16-channel discrete relay)
  - Output module: 1756-OF8 (8-channel analog voltage/current)
  - Output module: 1756-OF6CI (8-channel analog current)

### **Final Control Element options**

- Pneumatic control valve positioners
  - Fisher 3582i positioner (4-20 mA input)
  - Fisher DVC6000 positioner (4-20 mA input)
- Electrically actuated valves (MOV)
  - Limitorque actuator with Modutronic-20 II controller (4-20 mA input)
  - Rotork AQ with Folomatic controller (4-20 mA input)
- Electric solenoid valve (generic 24 VDC coil)
- Electric solenoid valve (generic 120 VAC coil)
- AC motor drives (VFD)
  - Rockwell PowerFlex 4 (4-20 mA input)
  - Rockwell PowerFlex 4 (discrete “run” input in SNK mode)
  - Rockwell PowerFlex 4 (discrete “run” input in SRC mode)
  - Automation Direct GS1 (4-20 mA input)
  - Automation Direct GS1 (discrete “forward” input)

[file i02599](#)

## Answers

---

Answer 1

Bear in mind that this is not the *only* possible circuit solution!

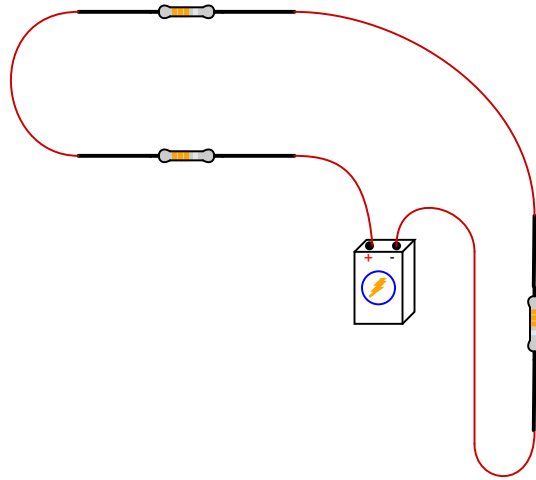

Challenge yourself by designing a different circuit to meet the same criteria!

---

Answer 2

Bear in mind that this is not the *only* possible circuit solution!

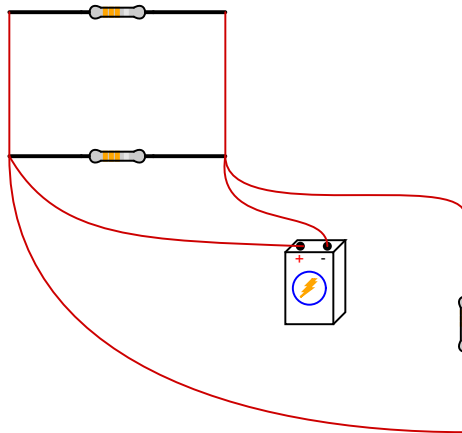

Challenge yourself by designing a different circuit to meet the same criteria!

---

Answer 3

Bear in mind that this is not the *only* possible circuit solution:

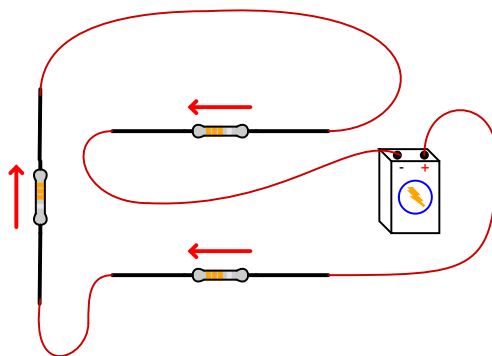

Challenge yourself by designing a different circuit to meet the same criteria!

---

Answer 4

Bear in mind that this is not the *only* possible circuit solution:

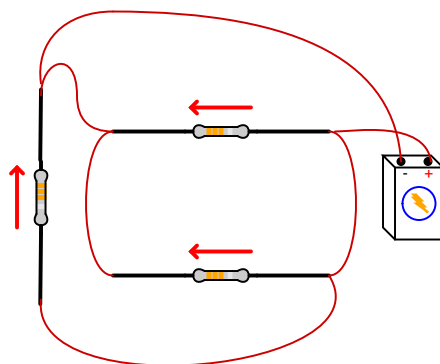

Challenge yourself by designing a different circuit to meet the same criteria!

---

Answer 5

Bear in mind that this is not the *only* possible circuit solution:

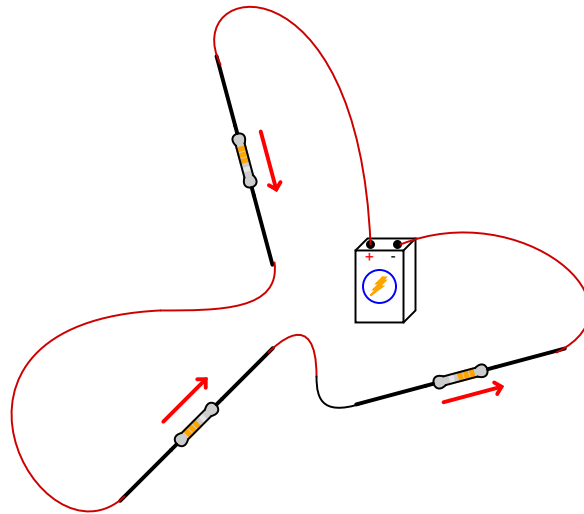

Challenge yourself by designing a different circuit to meet the same criteria!

---

Answer 6

Bear in mind that this is not the *only* possible circuit solution:

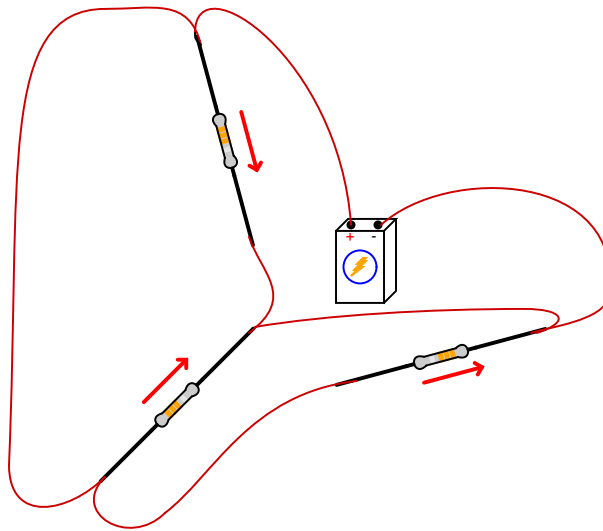

Challenge yourself by designing a different circuit to meet the same criteria!

---

Answer 7

Bear in mind that this is not the *only* possible circuit solution:

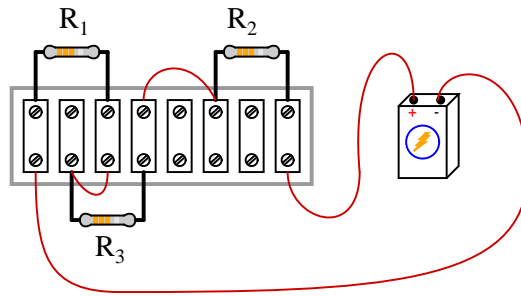

Challenge yourself by designing a different circuit to meet the same criteria!

---

Answer 8

Bear in mind that this is not the *only* possible circuit solution:

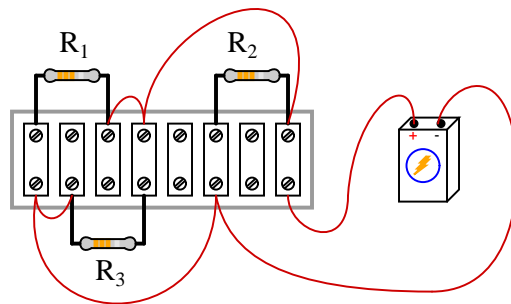

Challenge yourself by designing a different circuit to meet the same criteria!

---

Answer 9

Bear in mind that this is not the *only* possible circuit solution:

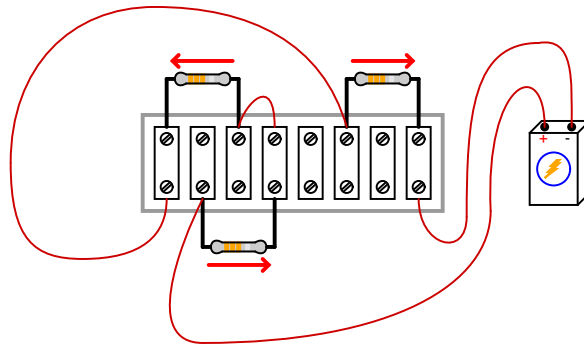

Challenge yourself by designing a different circuit to meet the same criteria!

---

Answer 10

Bear in mind that this is not the *only* possible circuit solution:

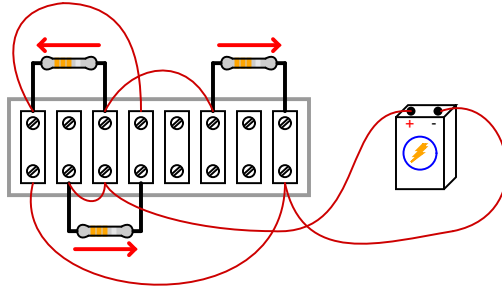

Challenge yourself by designing a different circuit to meet the same criteria!

---

Answer 11

Bear in mind that this is not the *only* possible circuit solution:

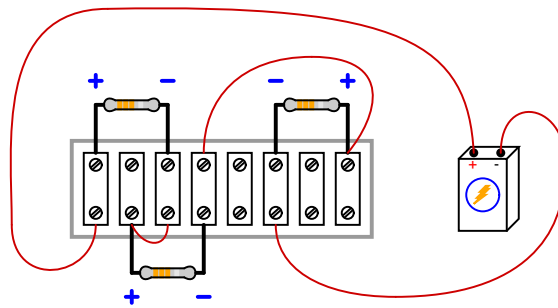

Challenge yourself by designing a different circuit to meet the same criteria!

---

Answer 12

Bear in mind that this is not the *only* possible circuit solution:

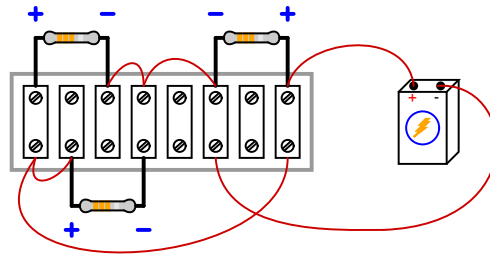

Challenge yourself by designing a different circuit to meet the same criteria!

---

Answer 13

Bear in mind that this is not the *only* possible circuit solution:

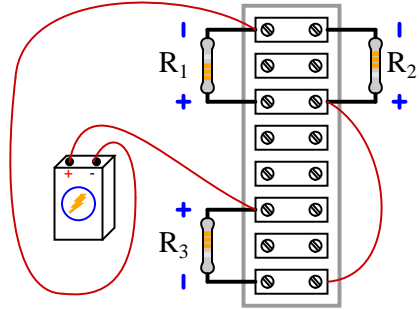

Challenge yourself by designing a different circuit to meet the same criteria!

---

Answer 14

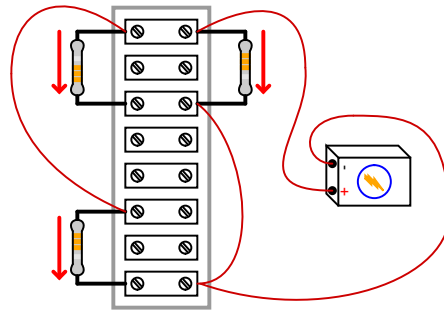

---

Answer 15

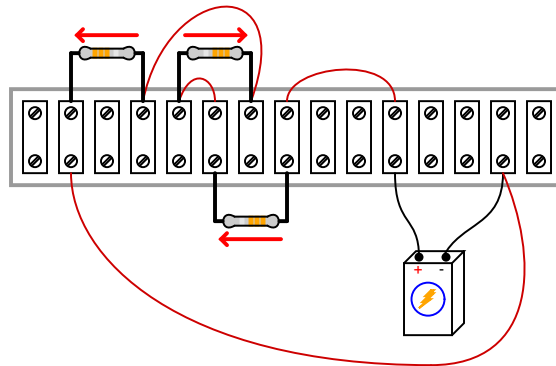

---

Answer 16

Bear in mind that this is not the *only* possible circuit solution:

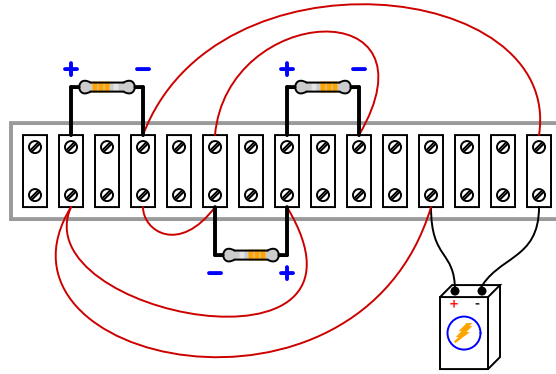

Challenge yourself by designing a different circuit to meet the same criteria!

---

Answer 17

Bear in mind that this is not the *only* possible circuit solution:

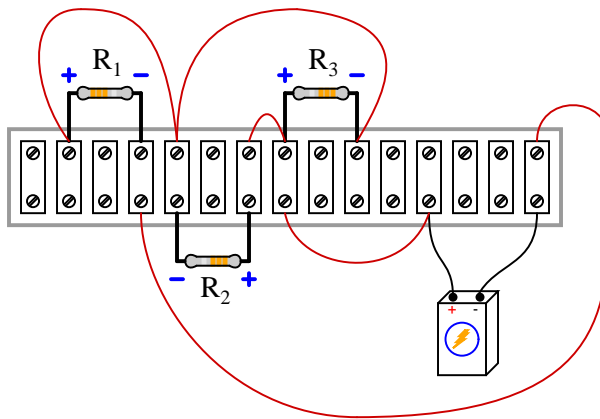

Challenge yourself by designing a different circuit to meet the same criteria!



---

Answer 18

Bear in mind that this is not the *only* possible circuit solution:

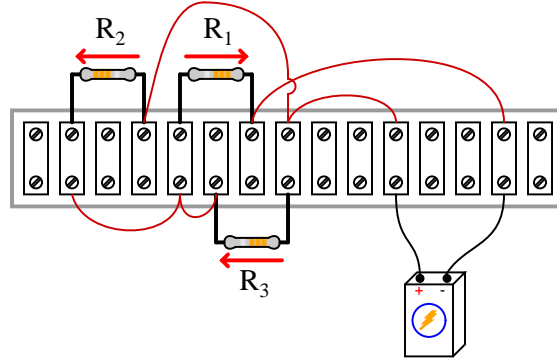

Challenge yourself by designing a different circuit to meet the same criteria!

---

Answer 19

Bear in mind that this is not the *only* possible circuit solution:

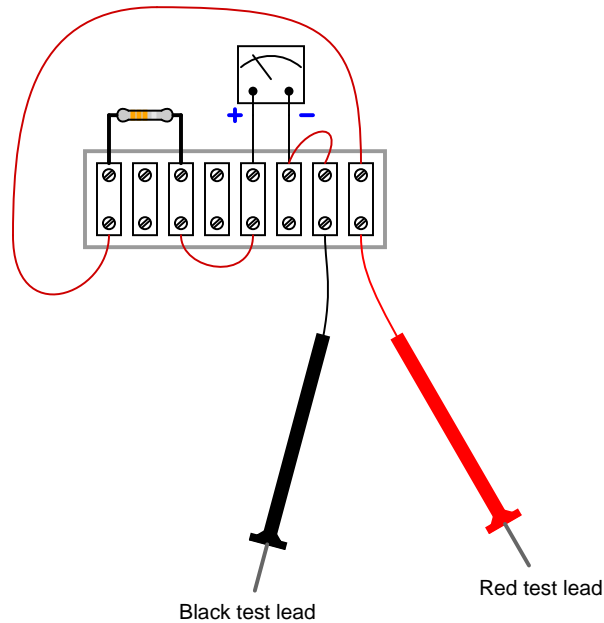

Challenge yourself by designing a different circuit to meet the same criteria!

---

Answer 20

Bear in mind that this is not the *only* possible circuit solution:

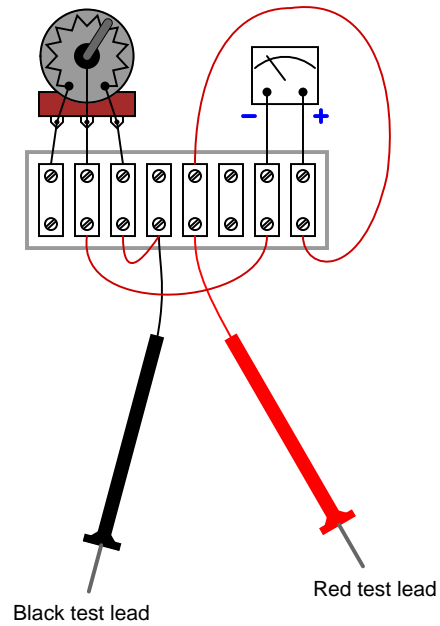

Challenge yourself by designing a different circuit to meet the same criteria!

---

Answer 21

Turning the knob clockwise will *decrease* the meter's sensitivity (i.e. make the needle move *less* with the same amount of applied voltage at the test lead tips). This is due to the potentiometer's resistance increasing between the left and center terminals as the wiper sweeps clockwise on the resistive strip.

---

Answer 22

Bear in mind that this is not the *only* possible circuit solution:

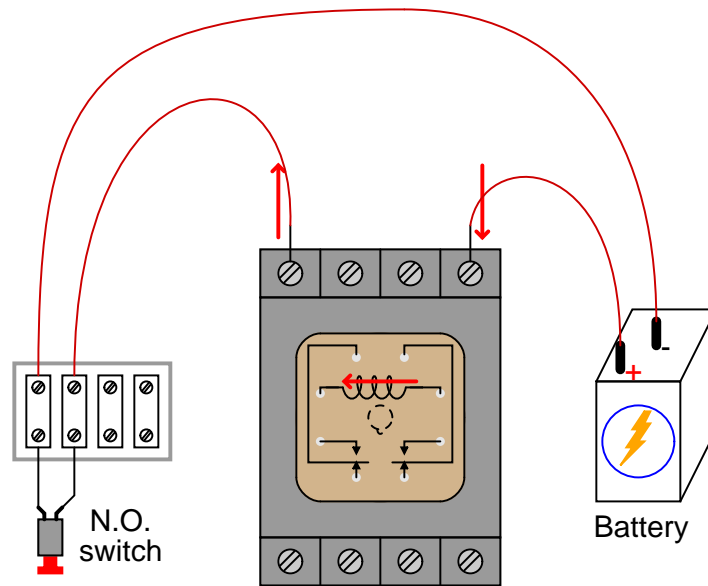

Challenge yourself by designing a different circuit to meet the same criteria!

---

Answer 23

Bear in mind that this is not the *only* possible circuit solution:

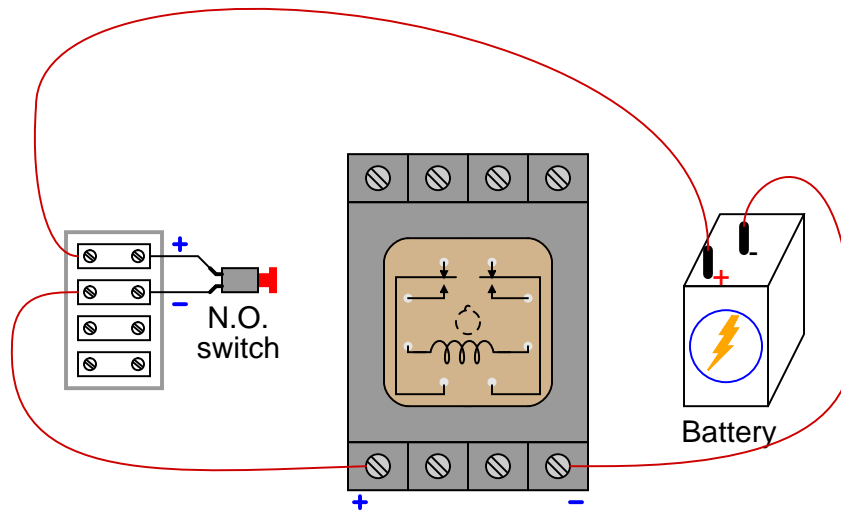

Challenge yourself by designing a different circuit to meet the same criteria!

Bear in mind that this is not the *only* possible circuit solution:

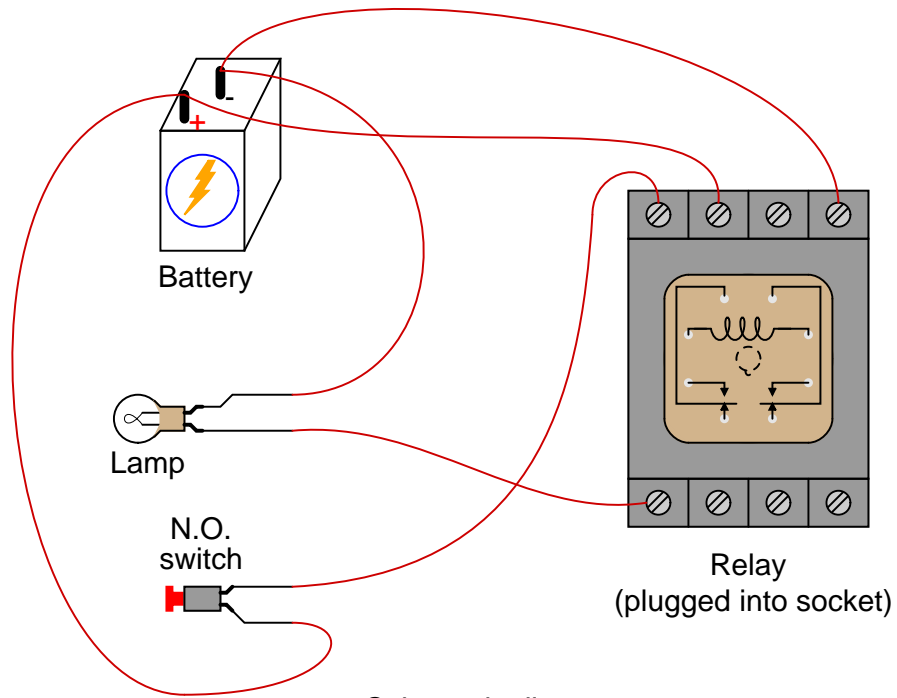

*Schematic diagram*

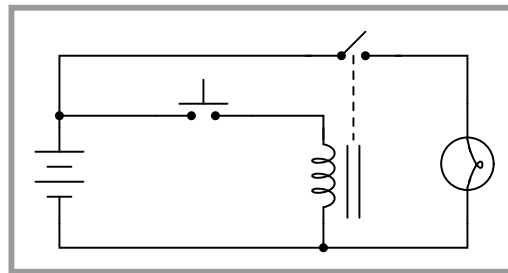

Challenge yourself by designing a different circuit to meet the same criteria!

Bear in mind that this is not the *only* possible circuit solution:

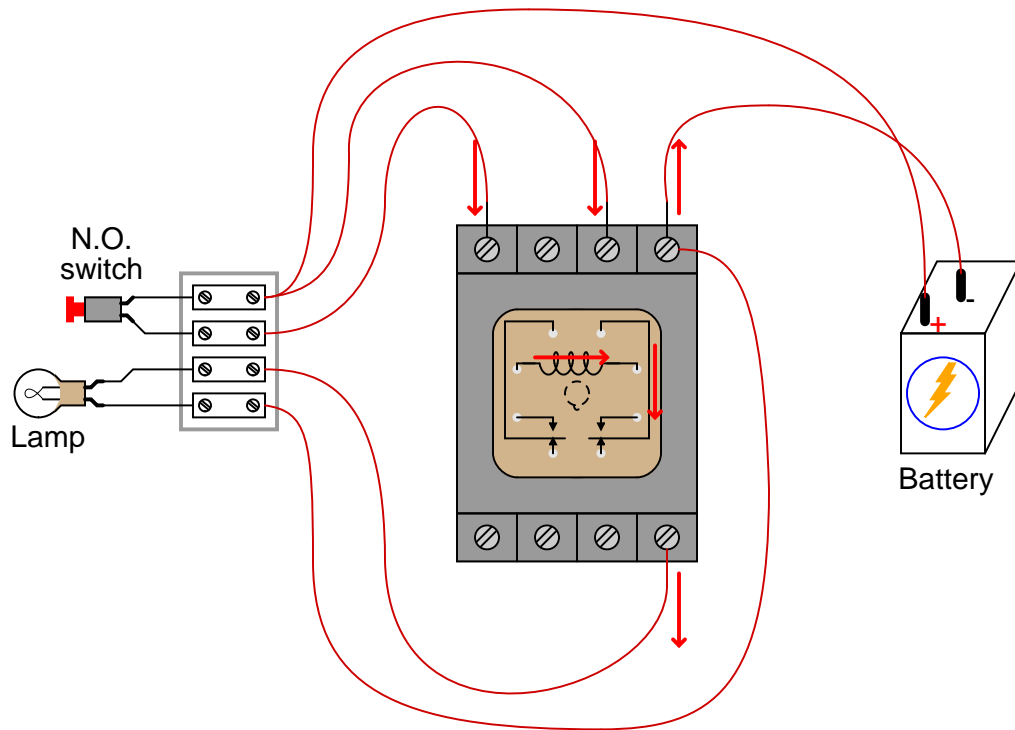

Challenge yourself by designing a different circuit to meet the same criteria!

Bear in mind that this is not the *only* possible circuit solution:

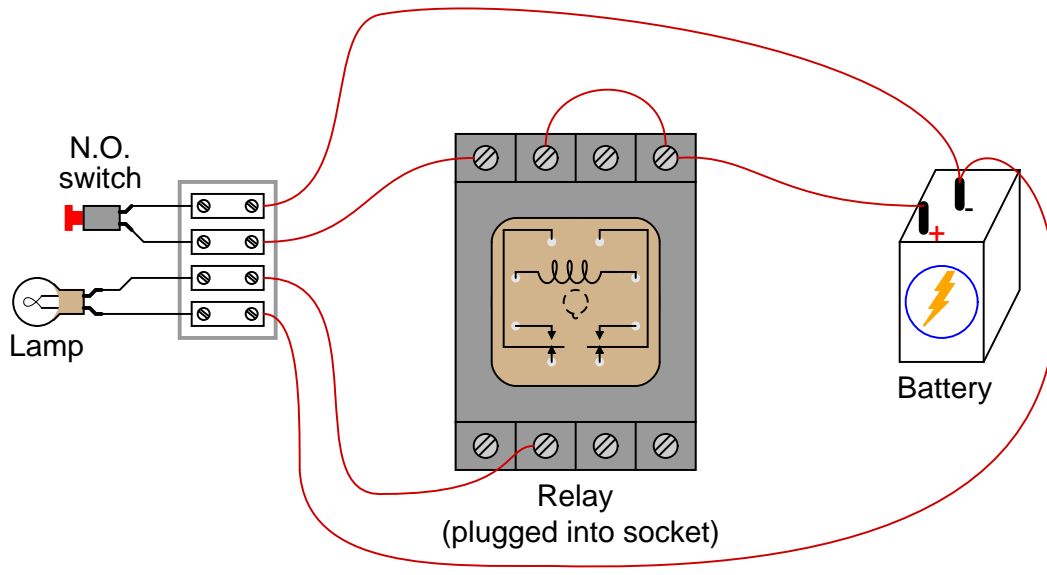

Challenge yourself by designing a different circuit to meet the same criteria!

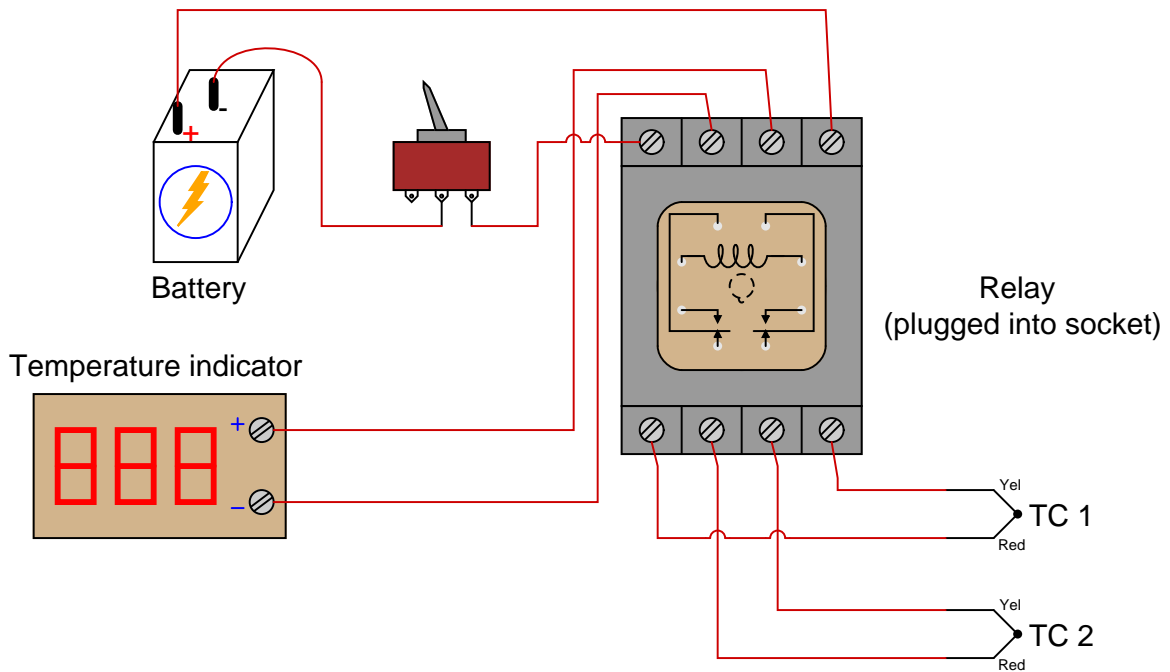

*Schematic diagram*

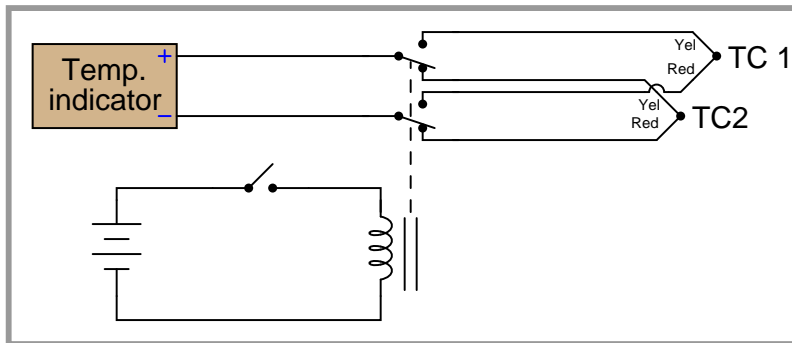

Bear in mind that this is not the *only* possible circuit solution:

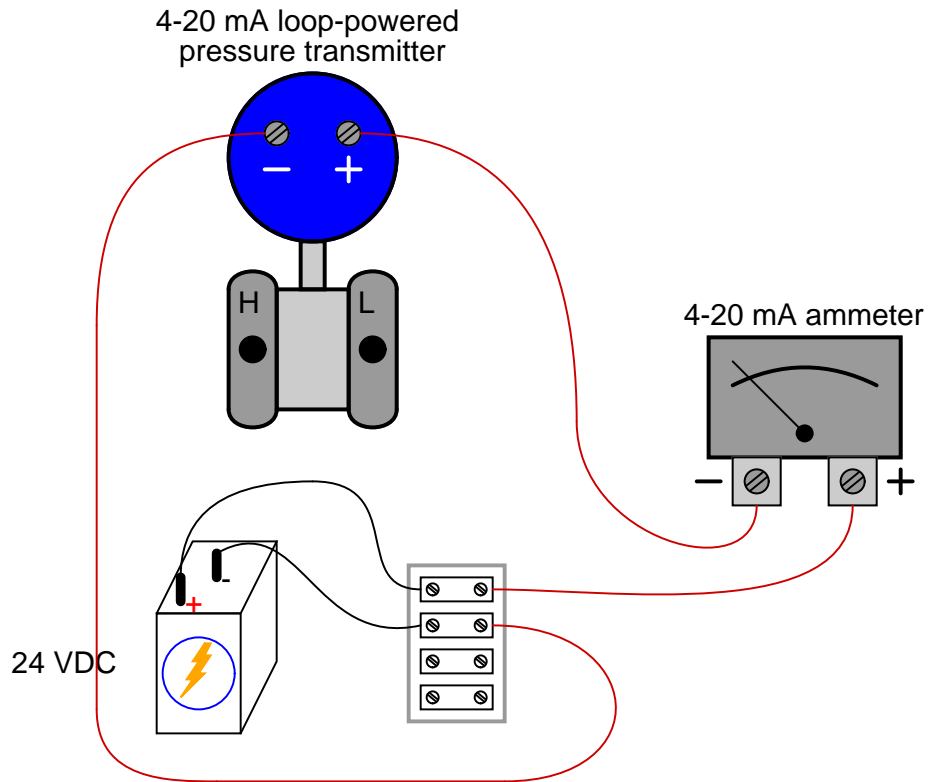

Challenge yourself by designing a different circuit that will also work!



Bear in mind that this is not the *only* possible circuit solution:

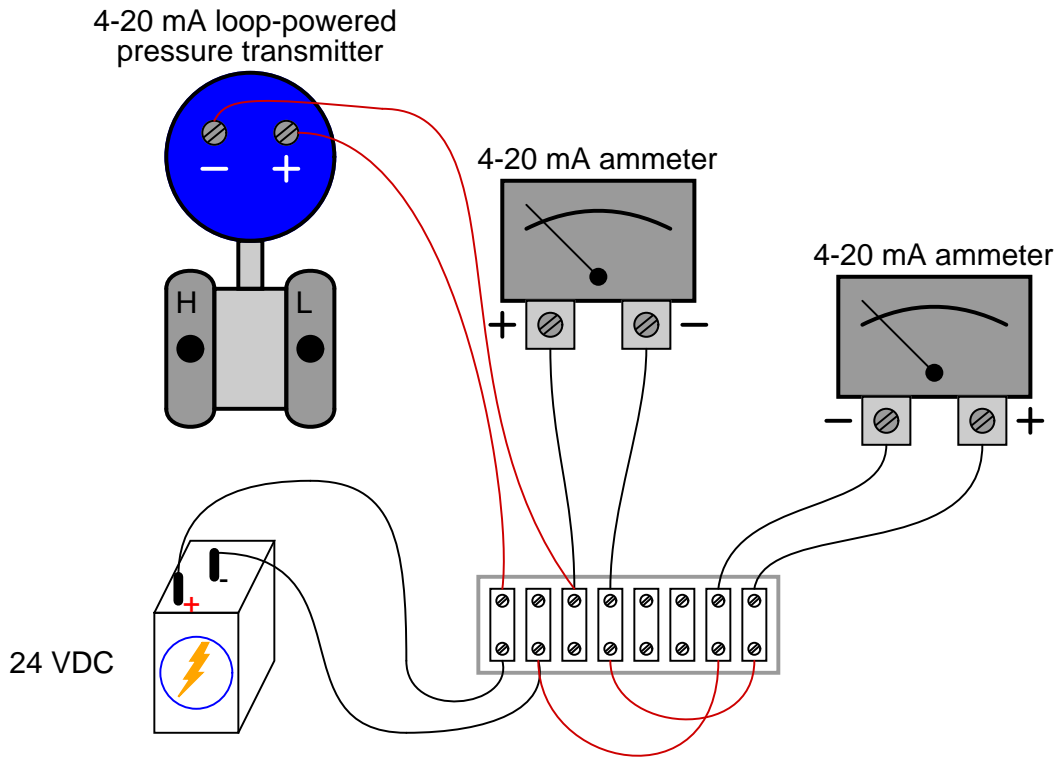

Challenge yourself by designing a different circuit that will also work!

Answer 30

IA/0 and IA/1 are both analog *voltage* inputs. We know this because of their large input resistances (210 k $\Omega$ ).

IA/2 and IA/3 are both analog *current* inputs. We know this because of their small input resistances (160  $\Omega$ ).

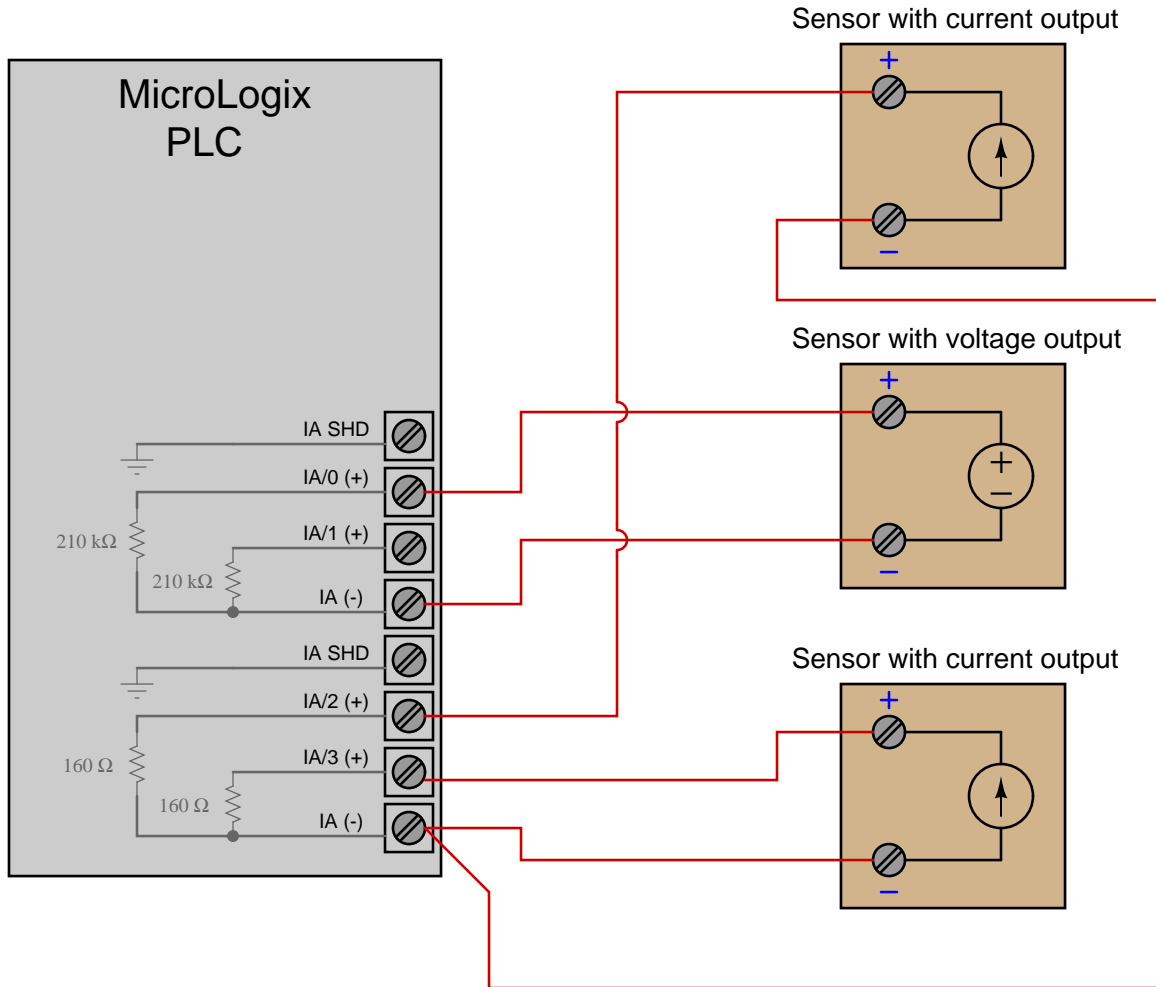

Bear in mind that this is not the *only* possible circuit solution:

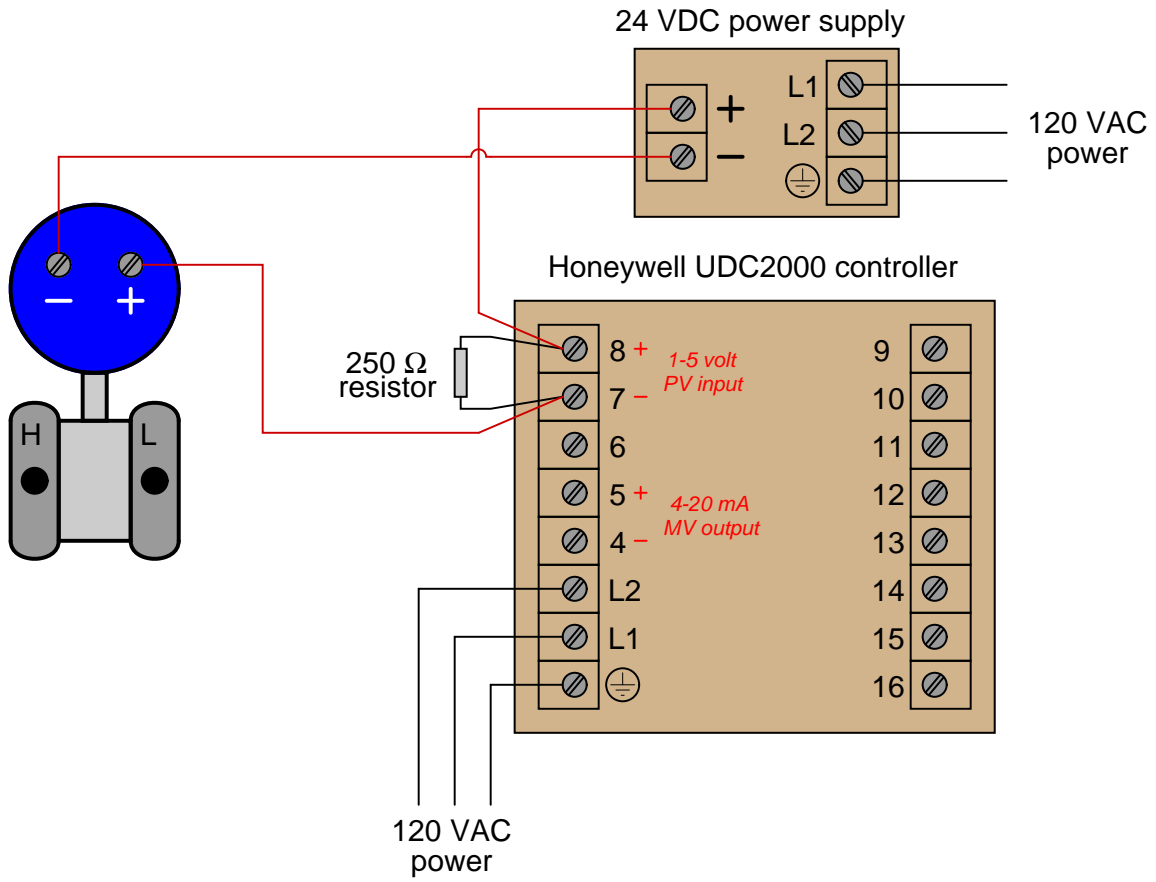

Challenge yourself by designing a different circuit to meet the same criteria!

Bear in mind that this is not the *only* possible circuit solution:

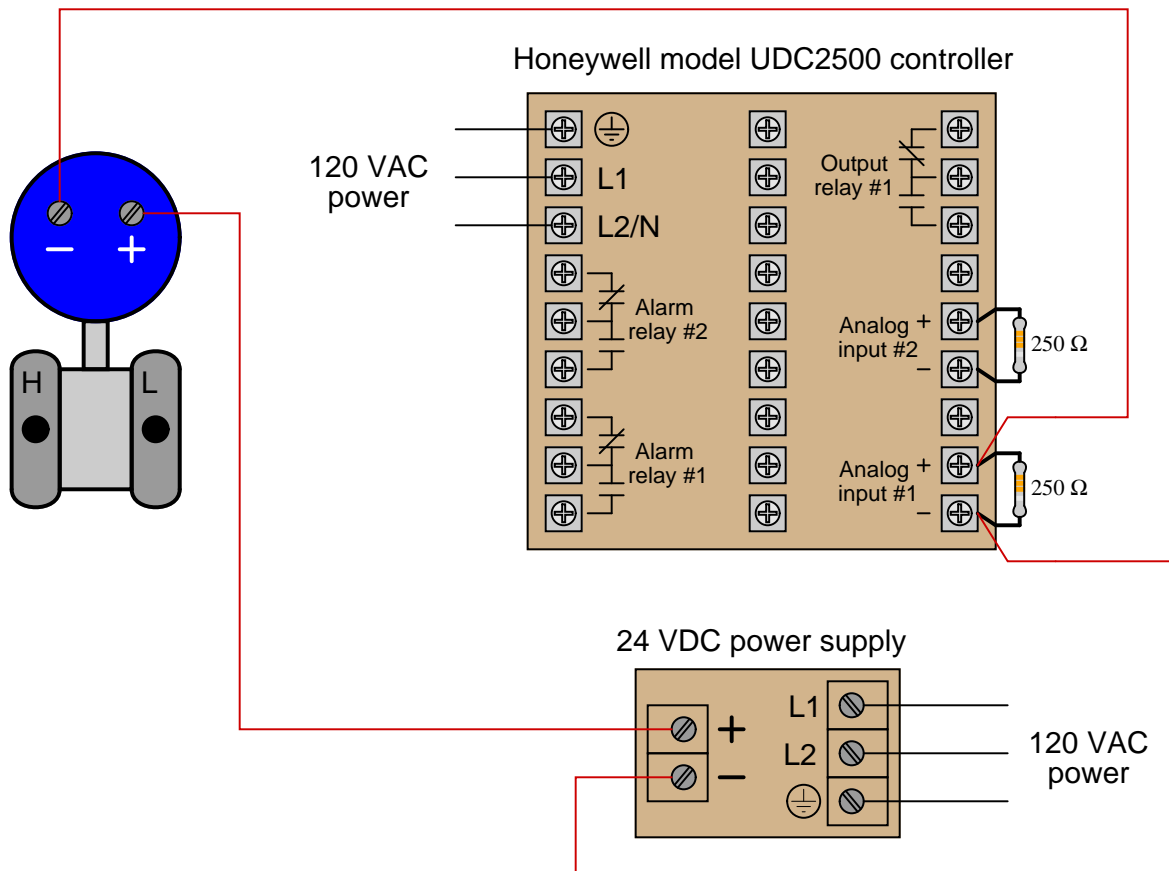

Challenge yourself by designing a different circuit to meet the same criteria!

Answer 33

This is a bit of a “trick” question, because there is no need for the 24 VDC power supply. The self-powered (4-wire) level transmitter functions as a current *source* rather than a current *regulator* as would be the case if it were loop-powered (2-wire)L

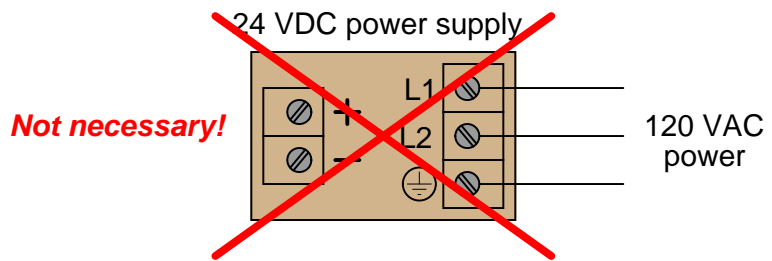
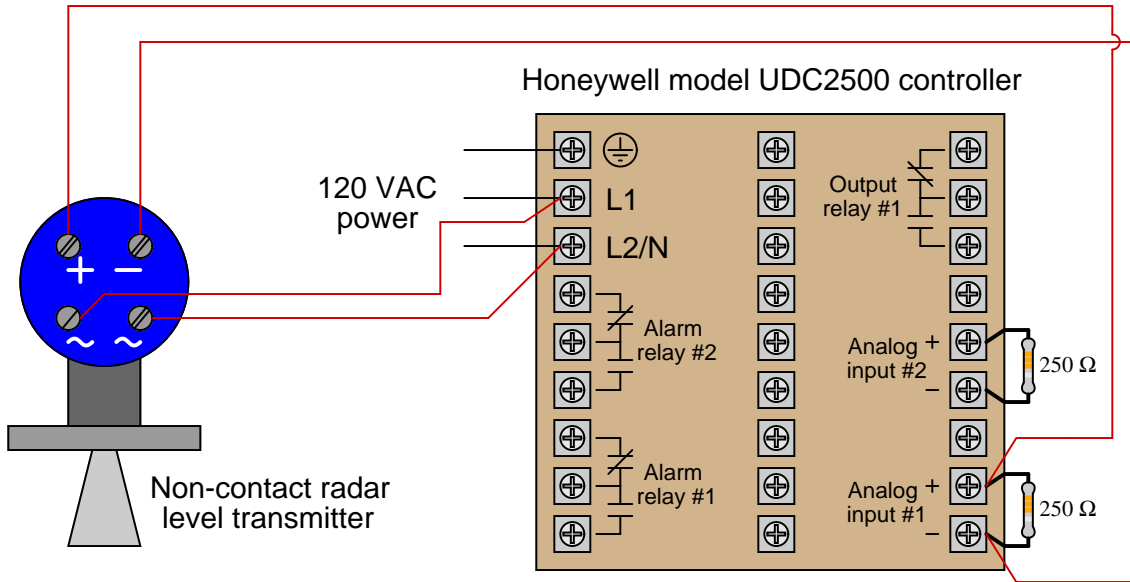

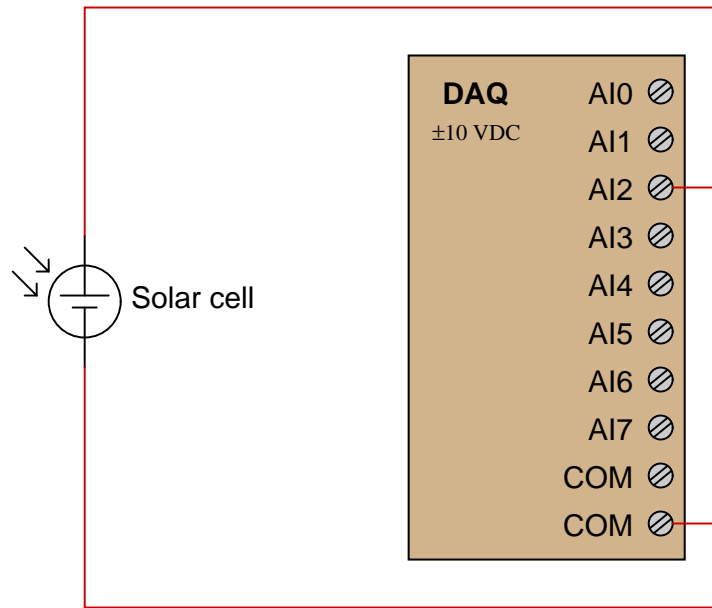

Challenge yourself by designing a different circuit to meet the same criteria!

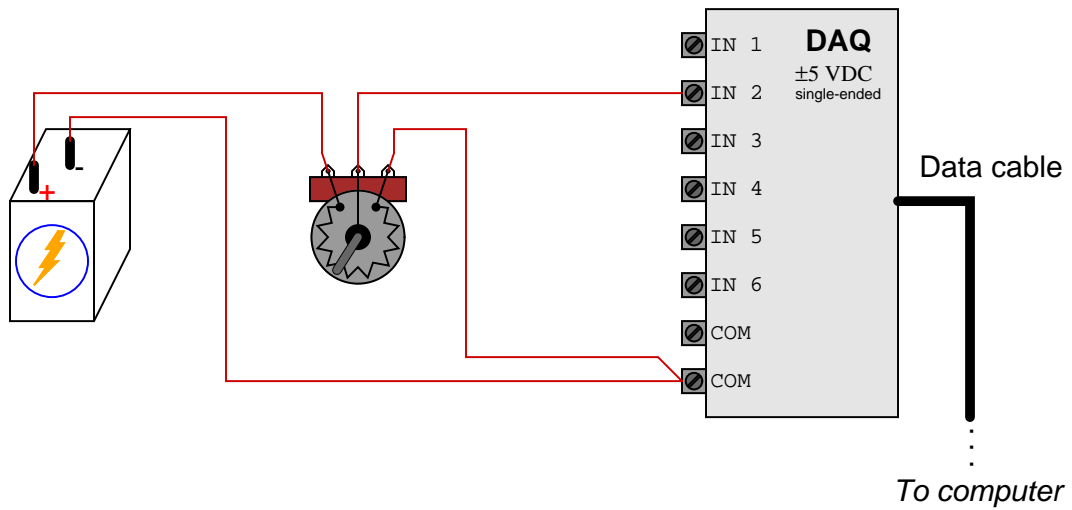

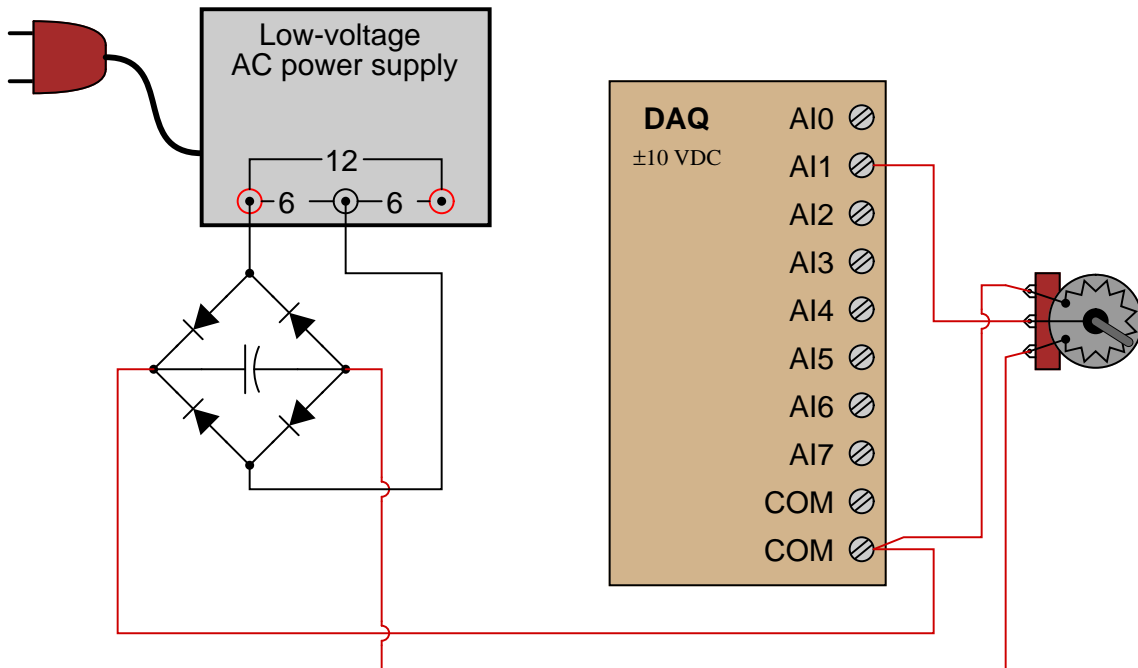
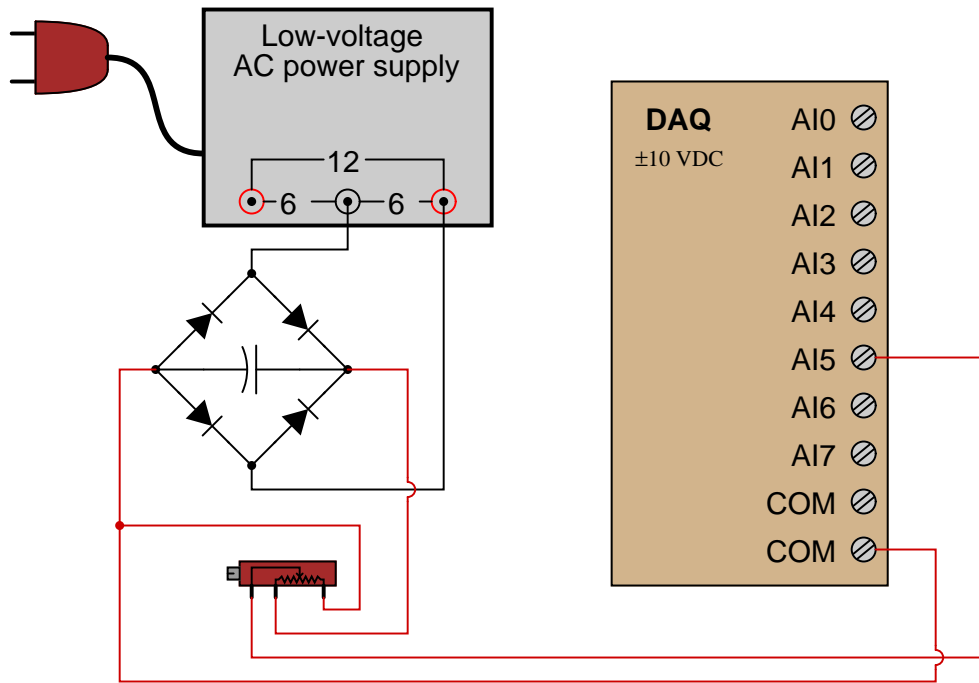

Remember that *stretching* a strain gauge causes its resistance to increase, while *compressing* a strain gauge causes its resistance to decrease:

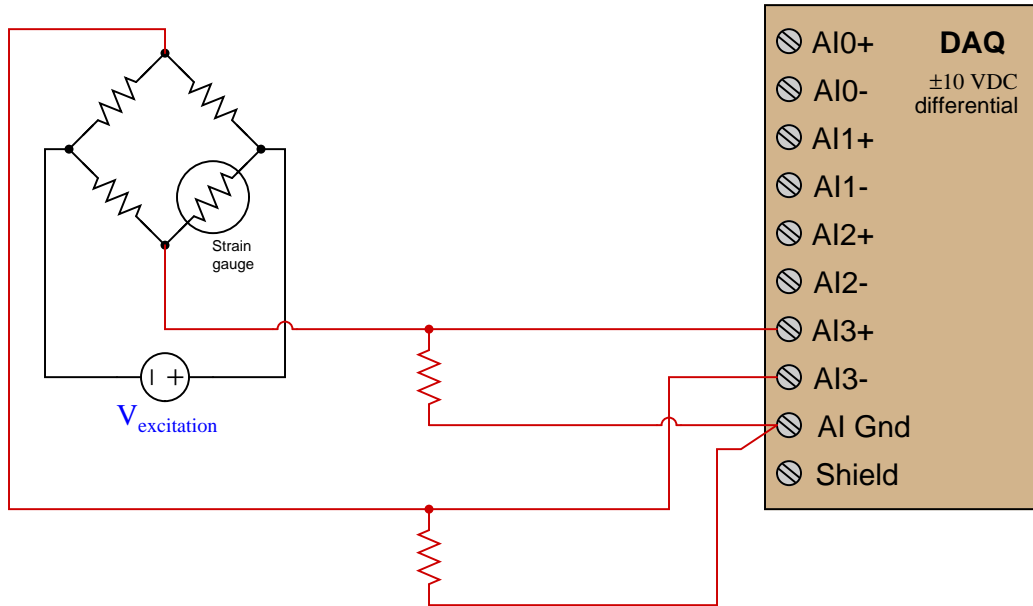

The two resistors (typically high-value, in the hundreds of kilo-ohms or even mega-ohms) provide a path for the DAQ's input bias currents, which is essential for a differential-input amplifier such as the instrumentation amplifier circuits inside the DAQ.



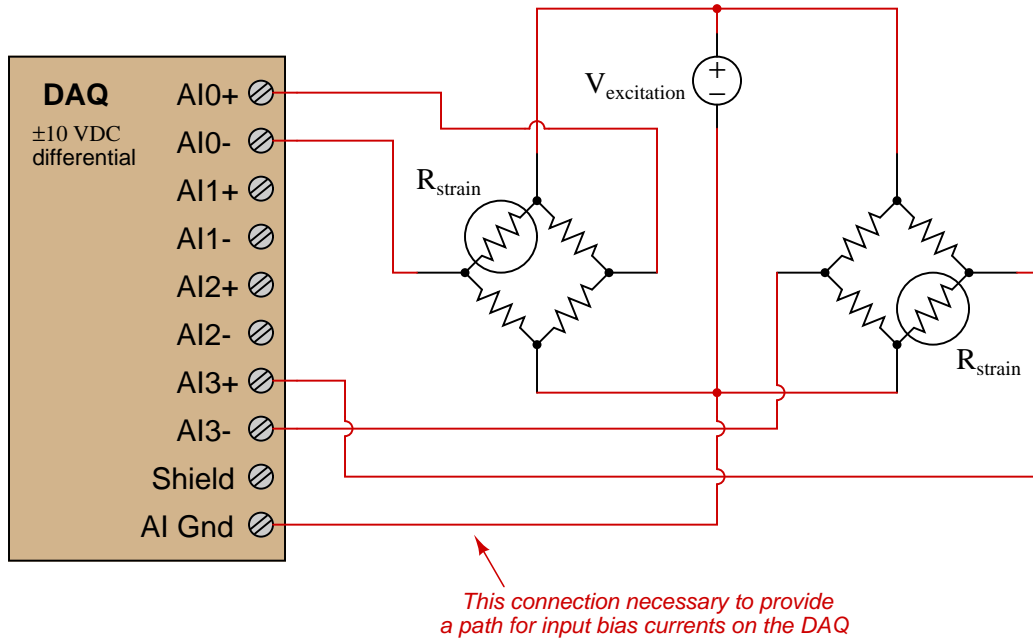

Challenge yourself by designing a different circuit to meet the same criteria!

Answer 40

The phrase “peak inverse voltage” refers to the maximum instantaneous voltage impressed across a diode in the diode’s reverse-bias (blocking) direction. Thus, the peak we wish to capture will be positive on the cathode and negative on the anode:

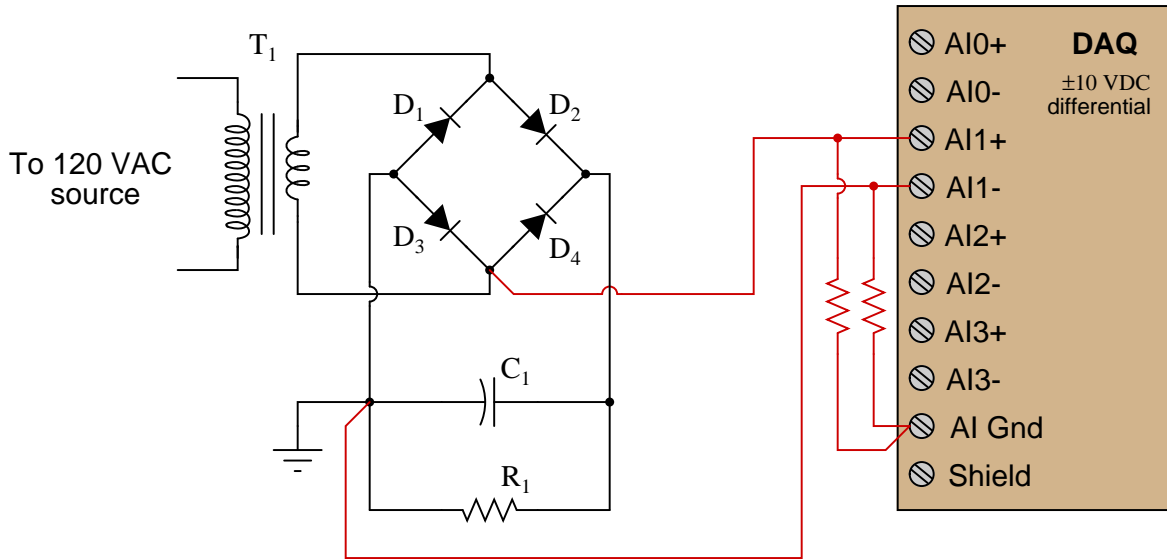

A simpler way to manage input bias currents on the DAQ is to simply connect one of the input terminals to the DAQ ground terminal like this (although doing so may yield results a bit less precise give the unequal bias current paths to ground):

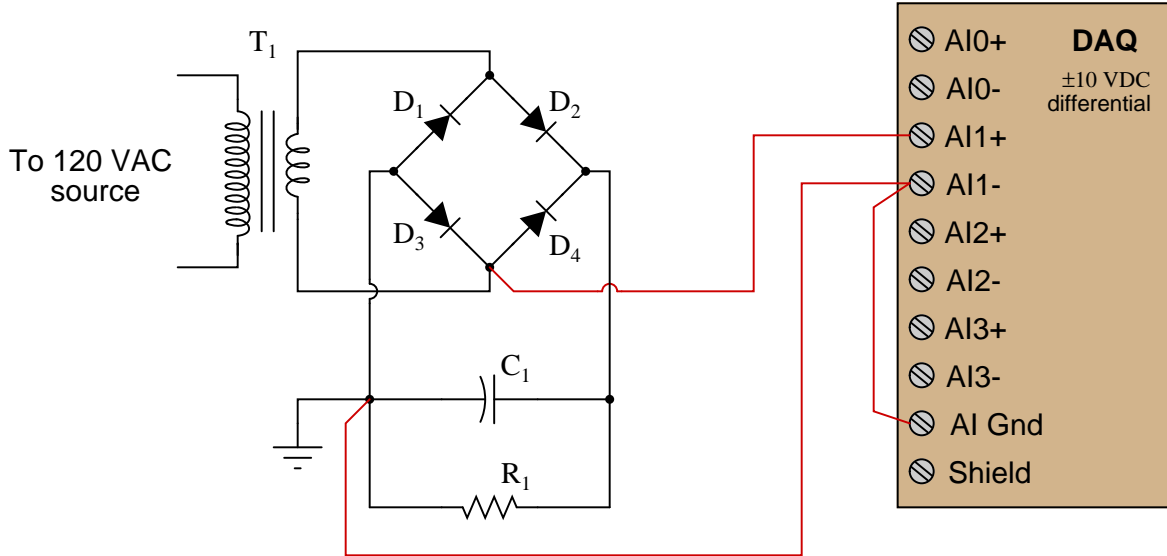

This is one possible solution:

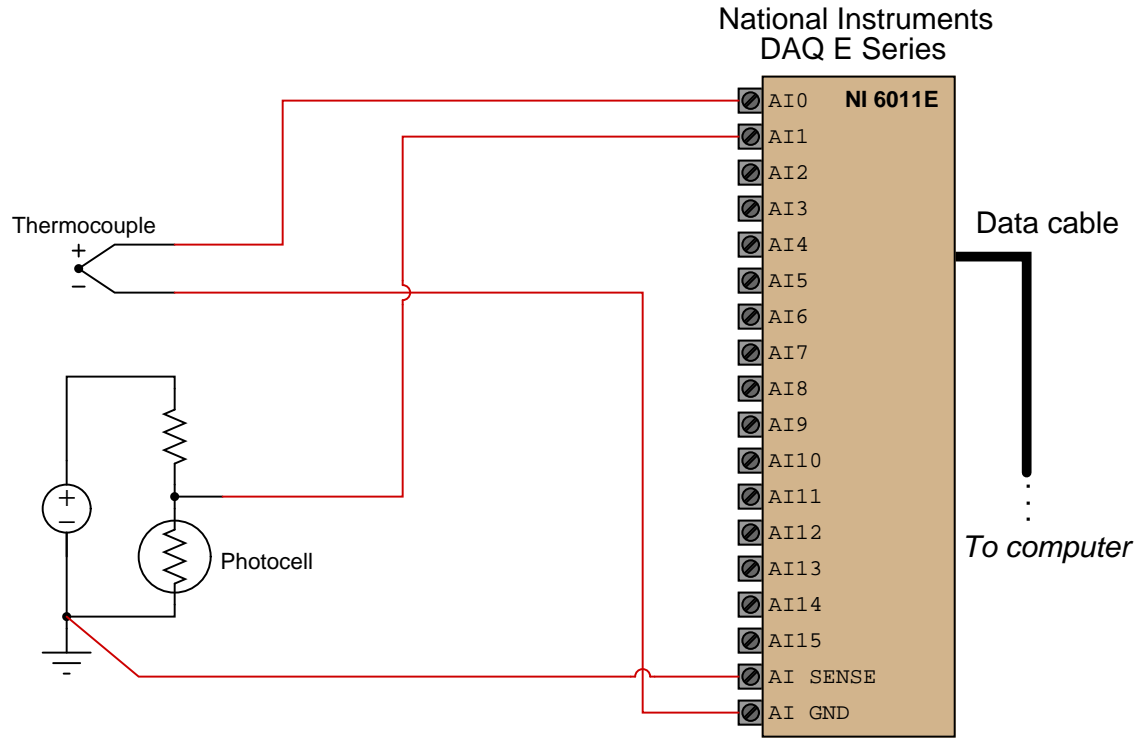

Channel	Mode	First terminal	Second terminal
0	RSE	AI0	AI Gnd
1	NRSE	AI1	AI Sense

