

Process switches and PLC circuits

This worksheet and all related files are licensed under the Creative Commons Attribution License, version 1.0. To view a copy of this license, visit <http://creativecommons.org/licenses/by/1.0/>, or send a letter to Creative Commons, 559 Nathan Abbott Way, Stanford, California 94305, USA. The terms and conditions of this license allow for free copying, distribution, and/or modification of all licensed works by the general public.

Questions

Question 1

Suppose we have a Koyo “CLICK” PLC connected to three pushbutton switches as shown in this illustration:

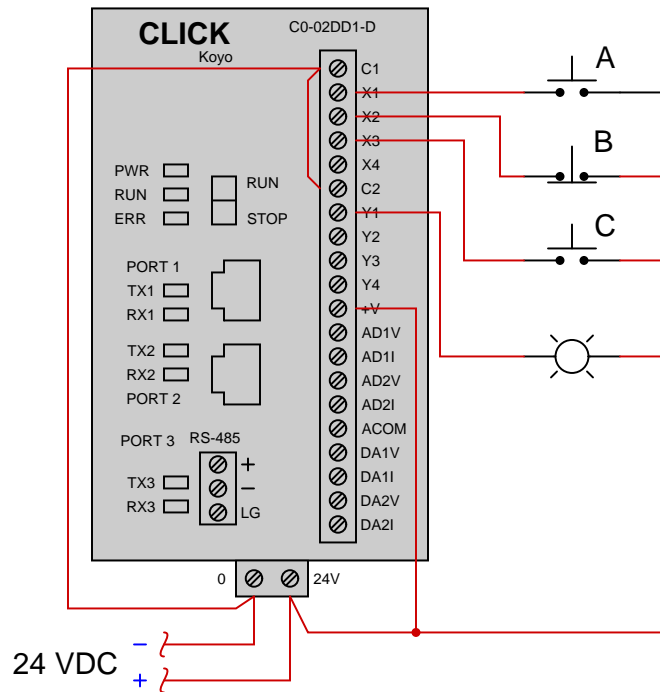

Determine the switch actuation statuses (i.e. pressed versus released) given the “live” display of the ladder logic program shown here:

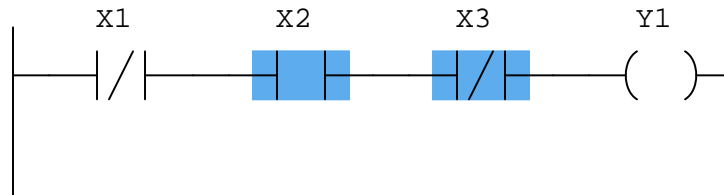

Also, determine the status of the lamp connected to the PLC's Y1 output.
[file i04666](#)

Question 2

Suppose we have a Koyo “CLICK” PLC connected to three process switches as shown in this illustration:

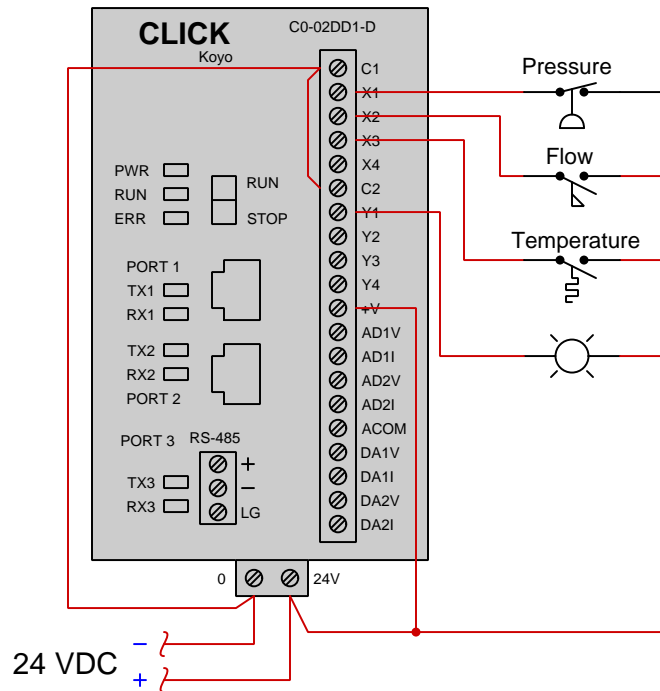

Determine the switch actuation statuses (i.e. low versus high process stimulus) given the “live” display of the ladder logic program shown here:

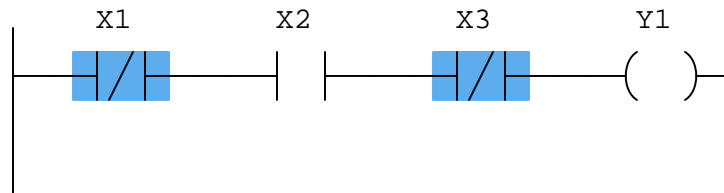

Also, determine the status of the lamp connected to the PLC’s Y1 output.

[file i02602](#)

Question 3

Suppose we have a Koyo “CLICK” PLC connected to three process switches as shown in this illustration:

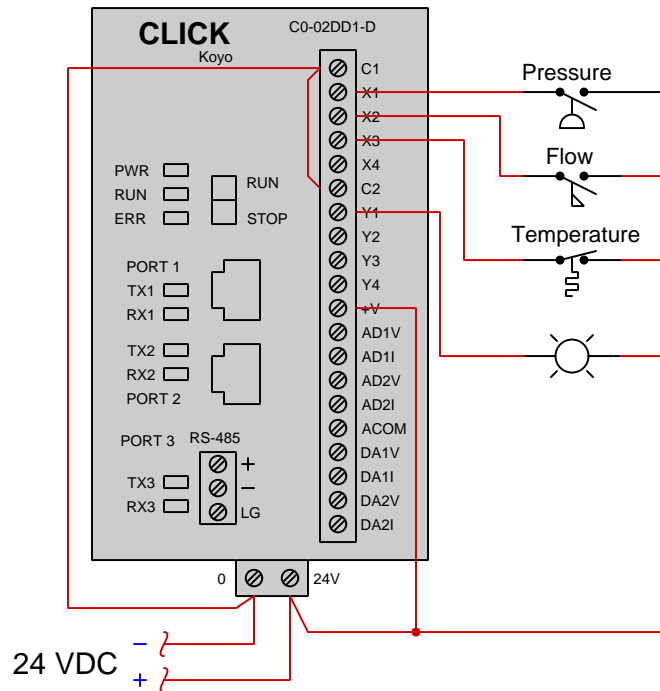

Determine the switch actuation statuses (i.e. low versus high process stimulus) given the “live” display of the ladder logic program shown here:

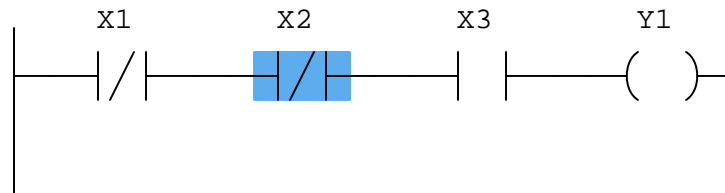

Also, determine the status of the lamp connected to the PLC’s Y1 output.

[file i02603](#)

Question 4

Suppose we have a Koyo “CLICK” PLC connected to three process switches as shown in this illustration:

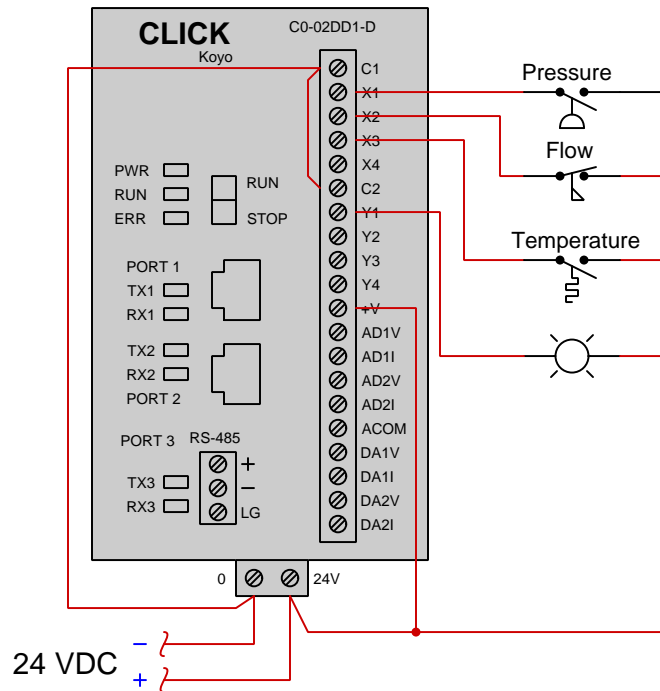

Determine the switch actuation statuses (i.e. low versus high process stimulus) given the “live” display of the ladder logic program shown here:

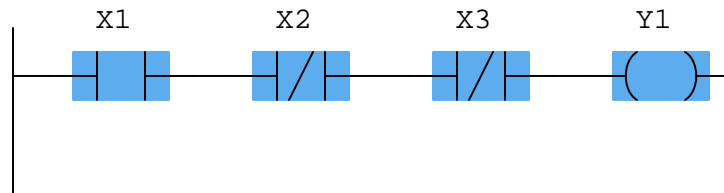

Also, determine the status of the lamp connected to the PLC’s Y1 output.

[file i02604](#)

Question 5

Suppose we have a Koyo “CLICK” PLC connected to three process switches as shown in this illustration:

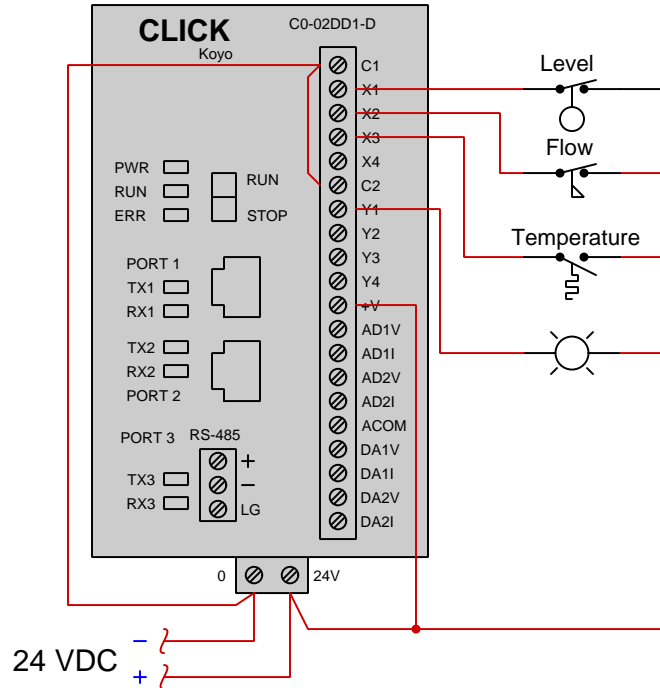

Determine the switch actuation statuses (i.e. low versus high process stimulus) given the “live” display of the ladder logic program shown here:

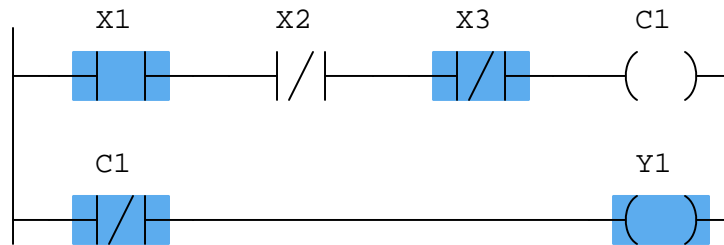

Also, determine the status of the lamp connected to the PLC’s Y1 output.

[file i02688](#)

Question 6

Suppose we have a Koyo "CLICK" PLC connected to three process switches as shown in this illustration:

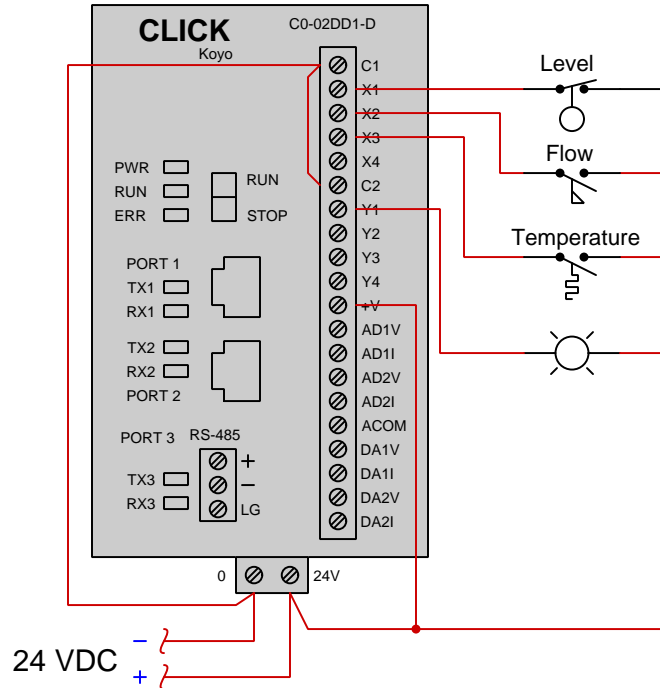

Determine the switch actuation statuses (i.e. low versus high process stimulus) given the "live" display of the ladder logic program shown here:

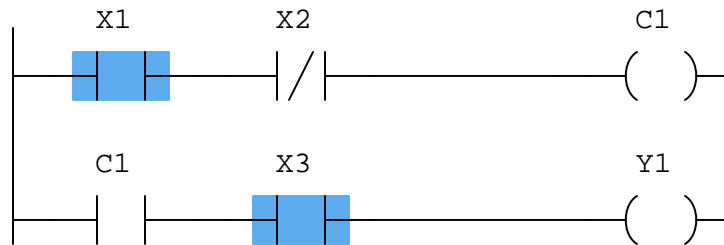

Also, determine the status of the lamp connected to the PLC's Y1 output.

[file i02689](#)

Question 7

Suppose we have a Koyo "CLICK" PLC connected to three pushbutton switches as shown in this illustration:

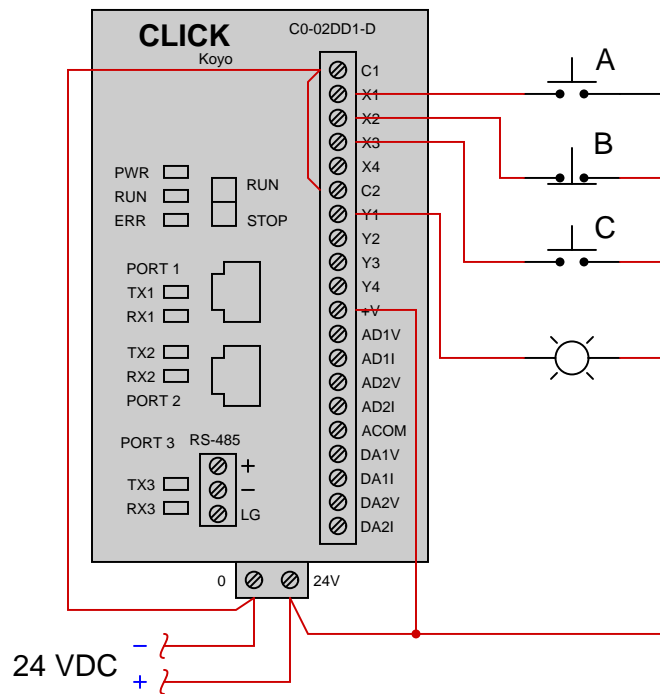

Determine the necessary switch actuation statuses (i.e. pressed versus unpressed) to turn the lamp on given the following program running in the PLC:

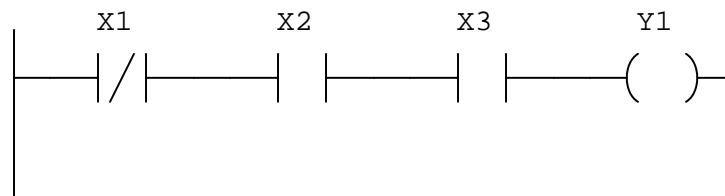

file i04637

Question 8

Suppose we have an Allen-Bradley MicroLogix 1000 controller connected to three pushbutton switches as shown in this illustration:

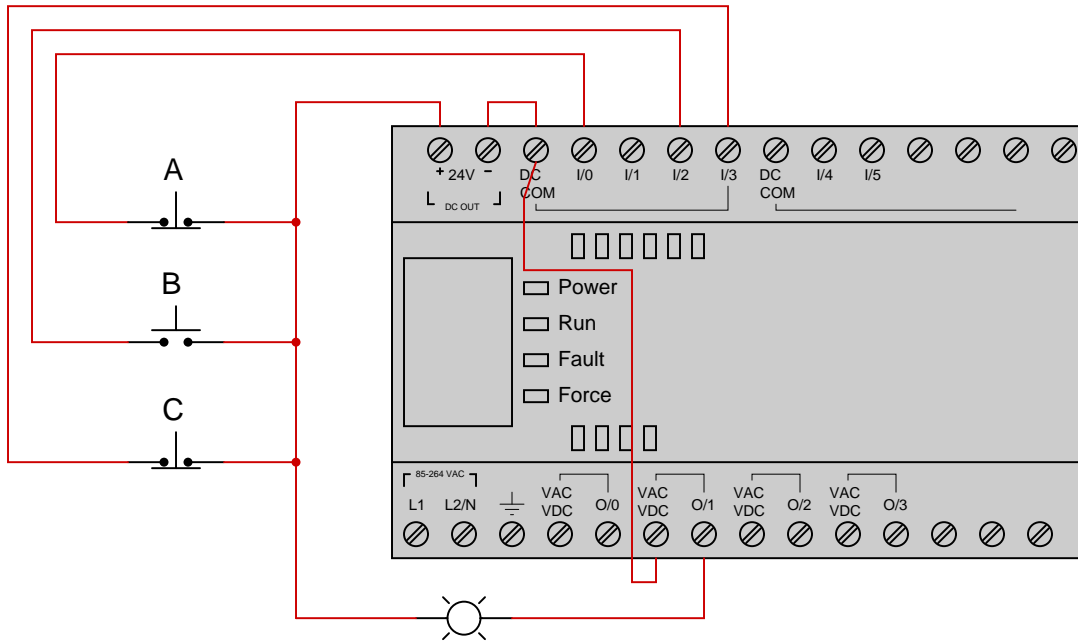

Determine the necessary switch actuation statuses (i.e. pressed versus unpressed) to turn the lamp on given the following program running in the PLC:

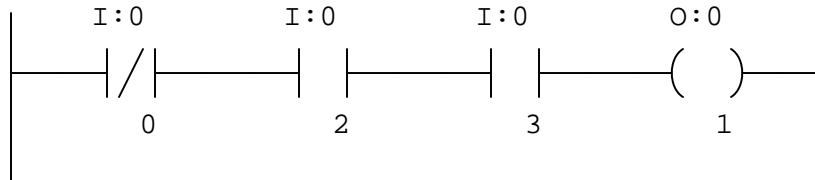

[file i04636](#)

Question 9

Suppose we have an Allen-Bradley model “SLC 500” PLC connected to a pair of pushbutton switches and light bulbs as shown in this illustration:

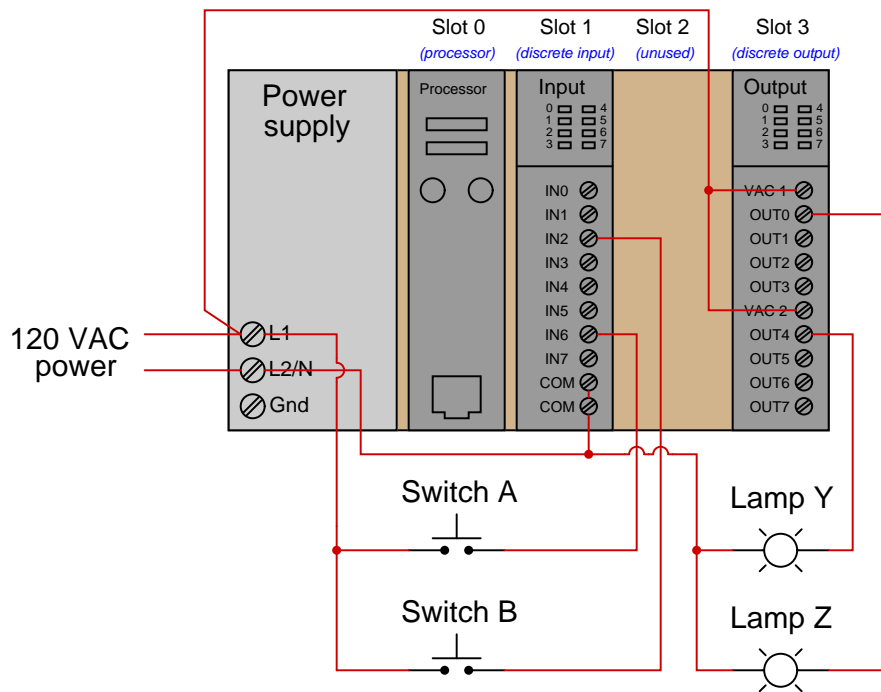

Examine the following relay ladder logic (RLL) program for this Allen-Bradley PLC, determining the necessary switch statuses to energize lamp Y, and the necessary switch statuses to energize switch Z:

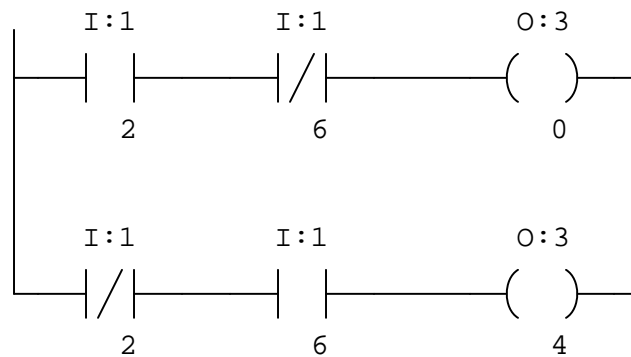

[file i04629](#)

Question 10

Suppose we have a Siemens S7-200 PLC connected to a pair of pushbutton switches and light bulbs as shown in this illustration:

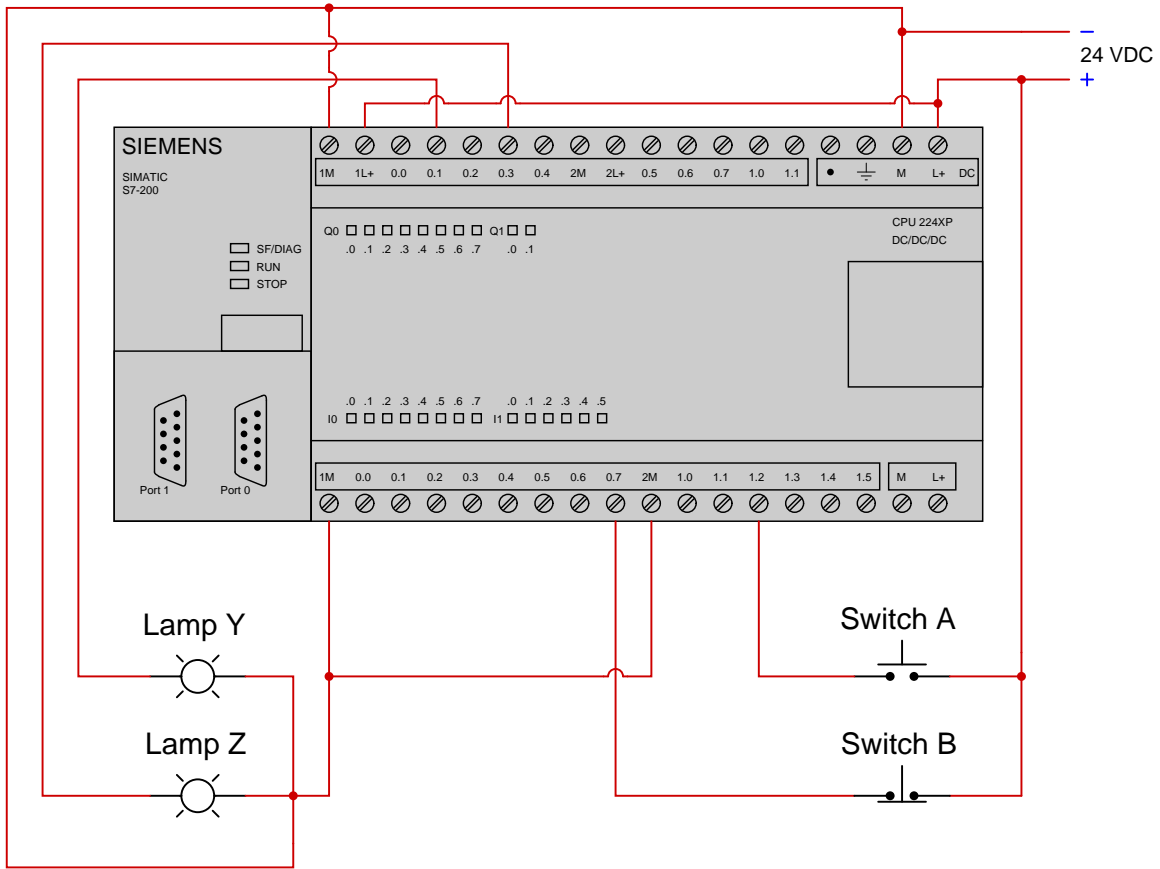

Examine the following relay ladder logic (RLL) program for this Siemens PLC, determining the statuses of the two lamps provided neither switch is pressed by a human operator:

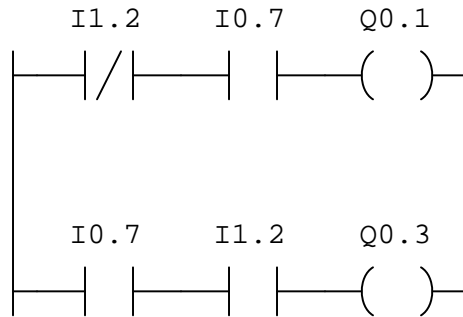

file i04630

Question 11

Suppose we have a Siemens S7-200 PLC connected to a pair of pushbutton switches and light bulbs as shown in this illustration:

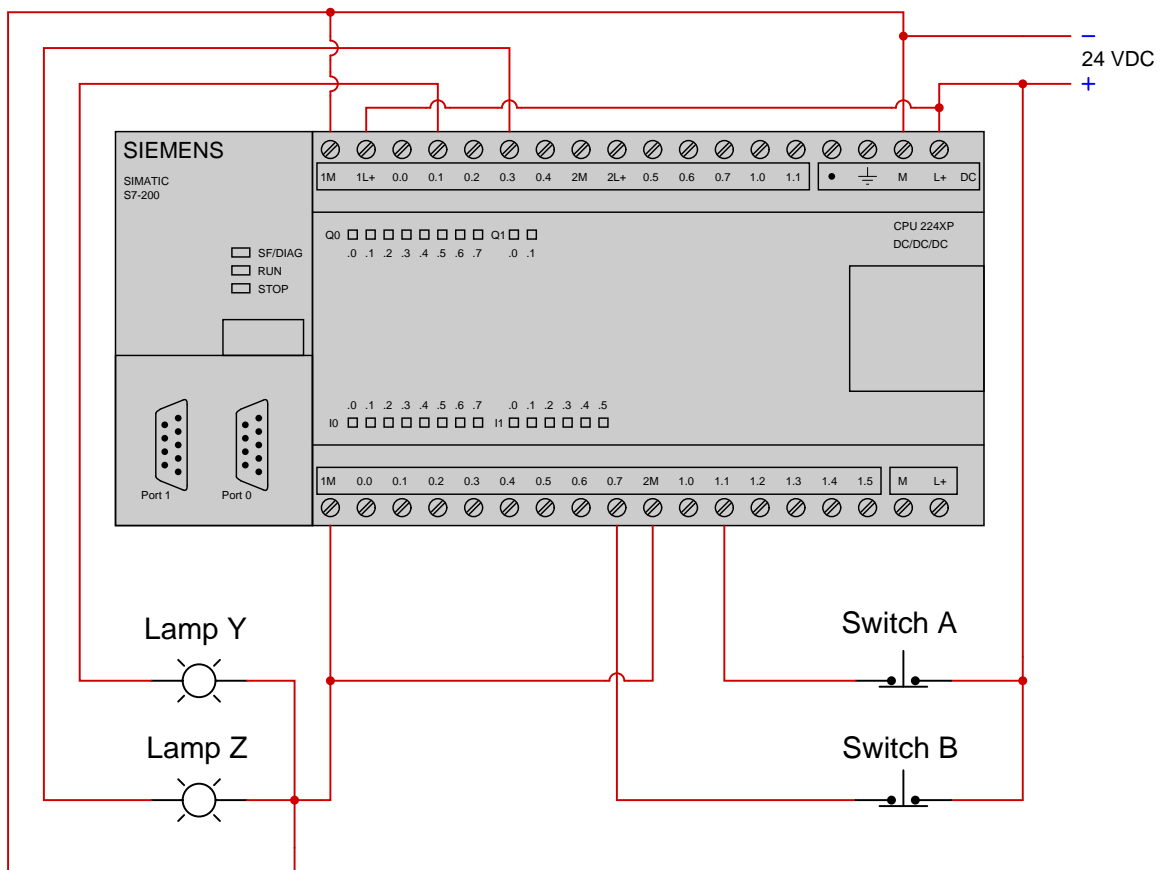

Examine the following relay ladder logic (RLL) program for this Siemens PLC, determining the statuses of the two lamps provided both switches are simultaneously pressed by a human operator:

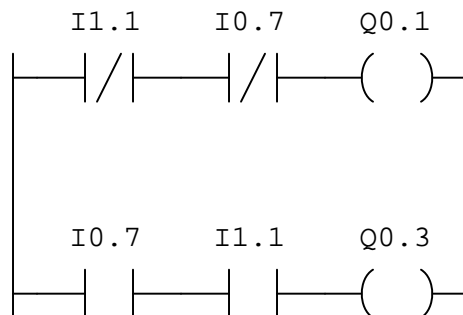

Furthermore, determine the necessary switch actuation statuses (i.e. pressed versus unpressed) to turn lamp Z on.

[file i04665](#)

Question 12

Suppose we have an Allen-Bradley MicroLogix 1000 controller connected to a pair of pushbutton switches and a contactor controlling power to an electric motor as shown in this illustration:

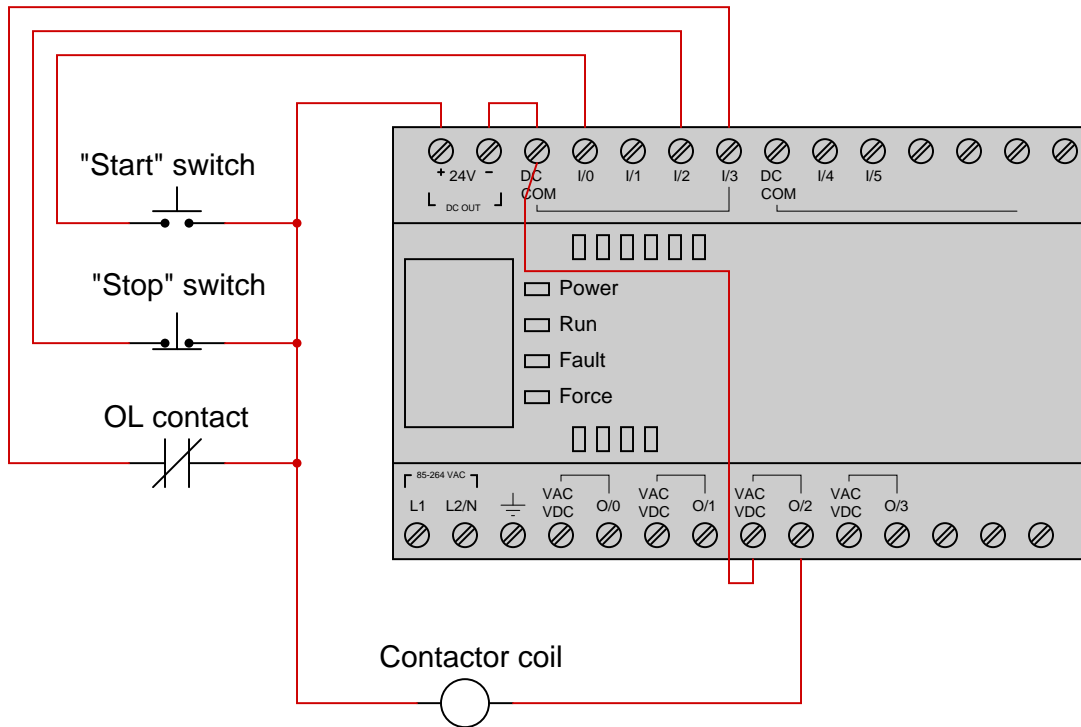

This motor control system has a problem, though: the motor refuses to start when the "Start" pushbutton is pressed. Examine the "live" display of the ladder logic program inside this Allen-Bradley PLC to determine what the problem is:

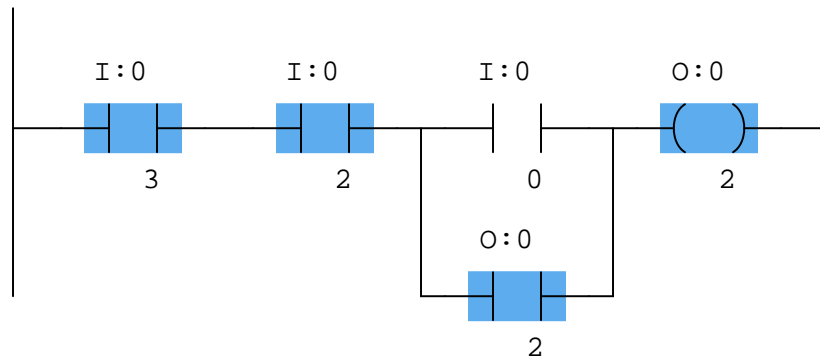

Identify at least two causes that could account for all you see here.
[file i04663](#)

Question 14

Suppose we have a Siemens S7-200 PLC connected to a pair of process switches and light bulbs as shown in this illustration:

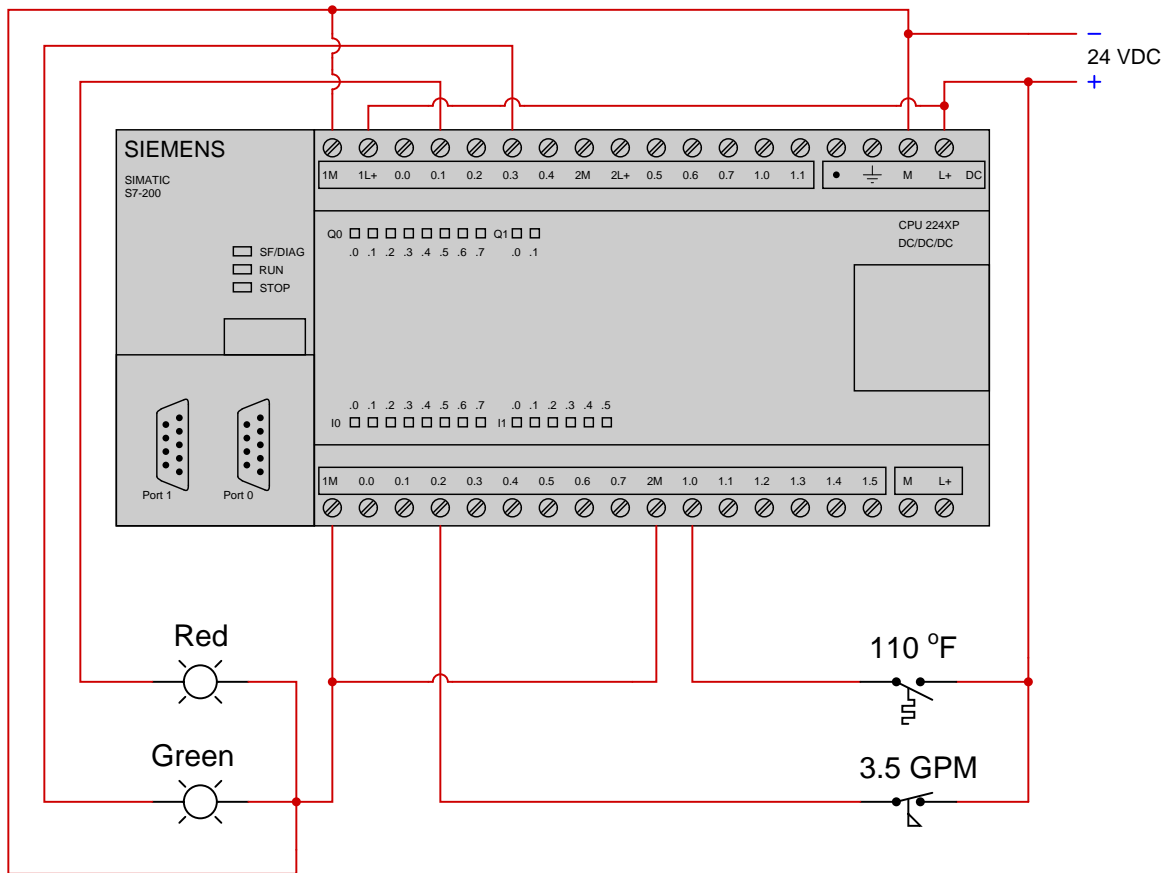

Examine the following relay ladder logic (RLL) program for this Siemens PLC, determining the statuses of the two lamps provided the temperature switch senses 102 °F and the flow switch senses 4.7 GPM:

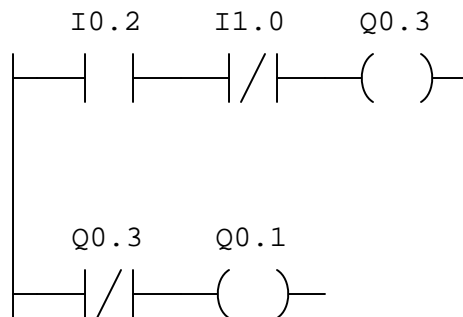

Also, determine whether the inputs on this PLC are *sourcing* or *sinking*, based on how they are connected to the process switches.

[file i02267](#)

Question 15

Suppose we have an Allen-Bradley MicroLogix 1000 controller connected to three pushbutton switches as shown in this illustration:

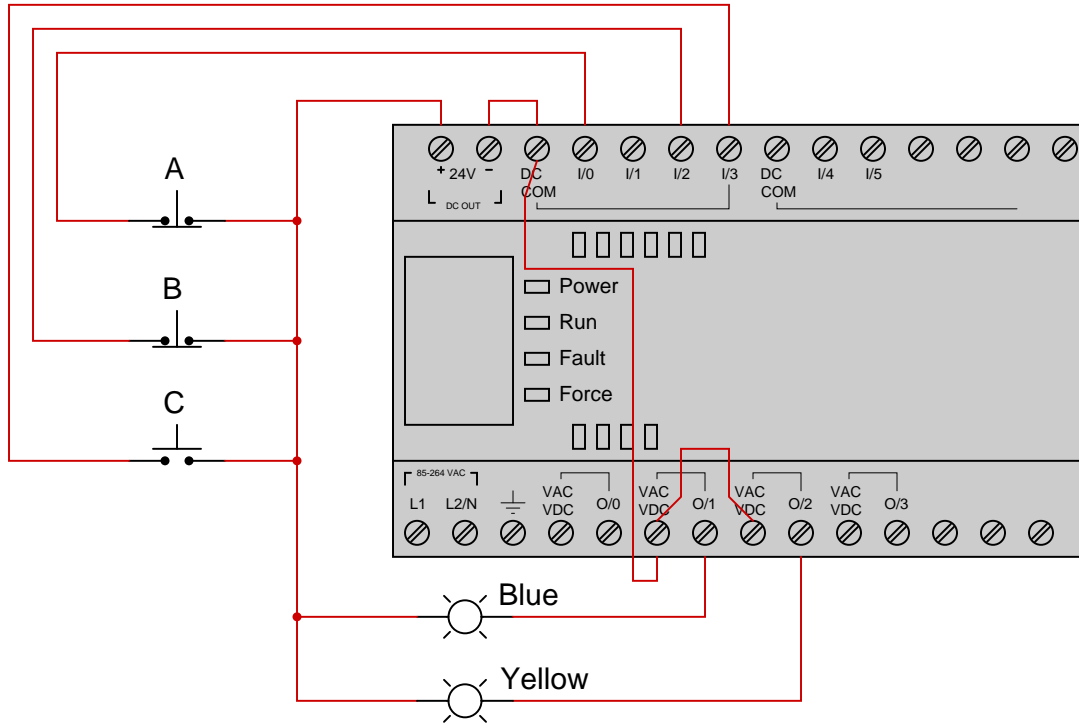

Determine the status of each lamp given the following program running in the PLC, assuming switch A is unpressed, switch B is pressed, and switch C is unpressed:

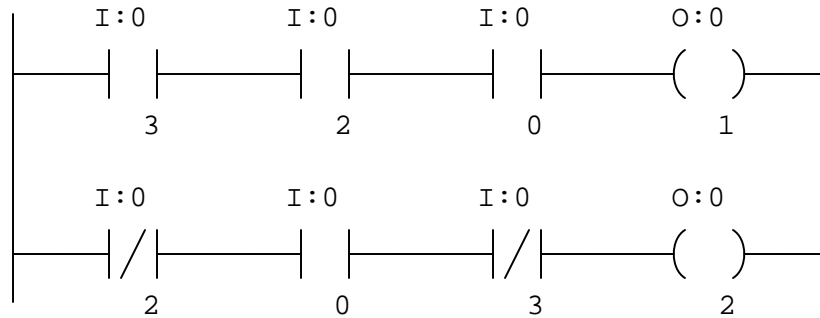

[file i04632](#)

Question 16

Suppose we have an Allen-Bradley MicroLogix 1000 controller connected to three pushbutton switches as shown in this illustration:

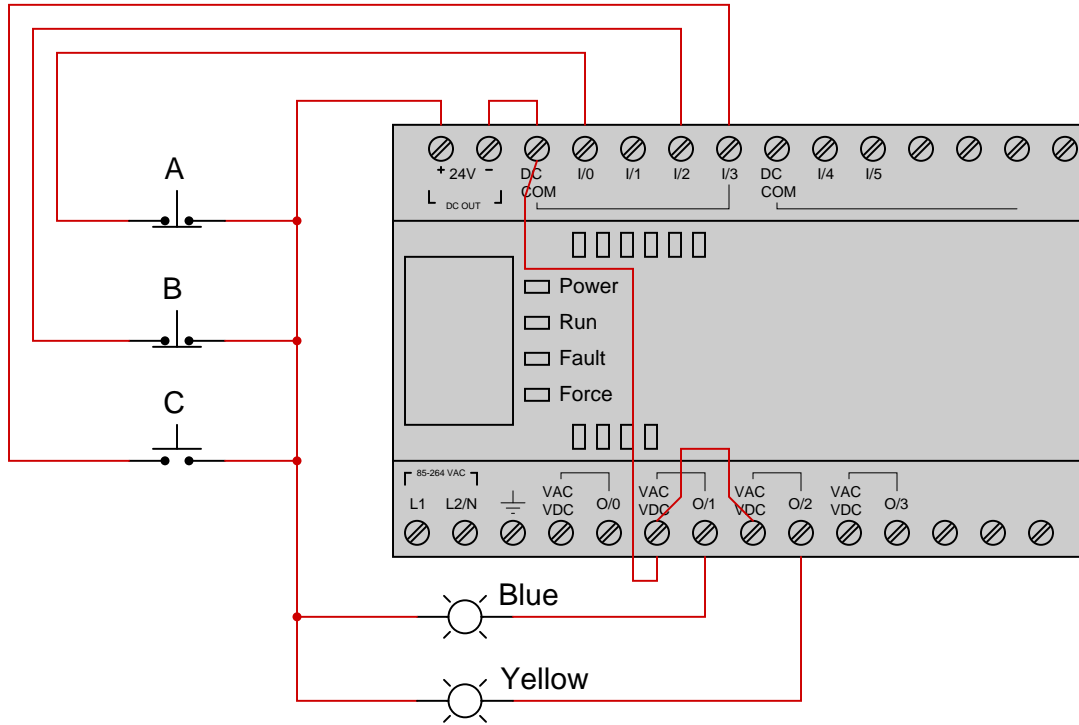

Determine the necessary switch actuation statuses (i.e. pressed versus unpressed) to turn the blue lamp on, given the following program running in the PLC:

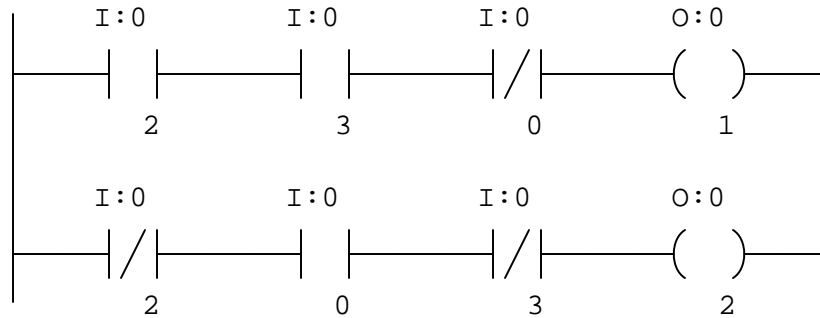

file i04633

Question 17

Suppose we have an Allen-Bradley MicroLogix 1000 controller connected to three process switches as shown in this illustration:

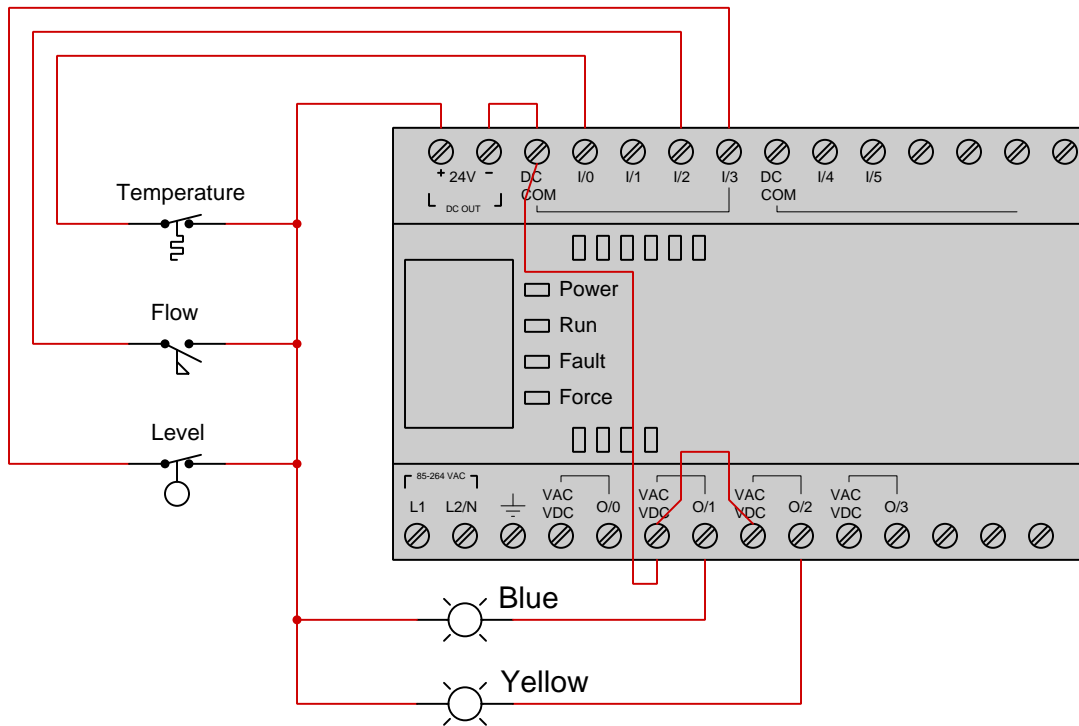

Determine the necessary switch actuation statuses (i.e. low versus high process stimulus) to turn the yellow lamp on, given the following program running in the PLC:

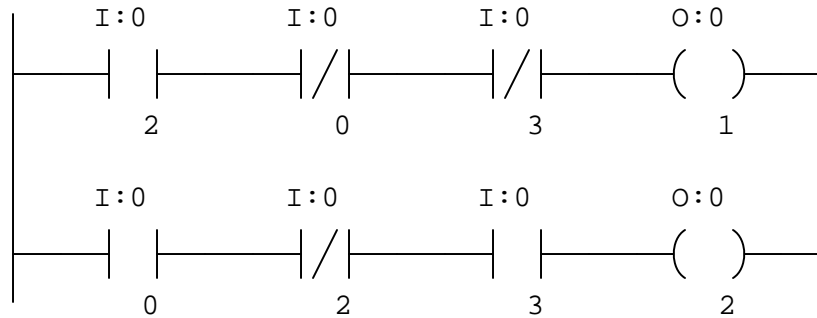

Next, determine the necessary switch actuation statuses (i.e. low versus high process stimulus) to turn the blue lamp on, given the same PLC program.

[file i02600](#)

Question 18

Suppose we have an Allen-Bradley MicroLogix 1000 controller connected to three process switches as shown in this illustration:

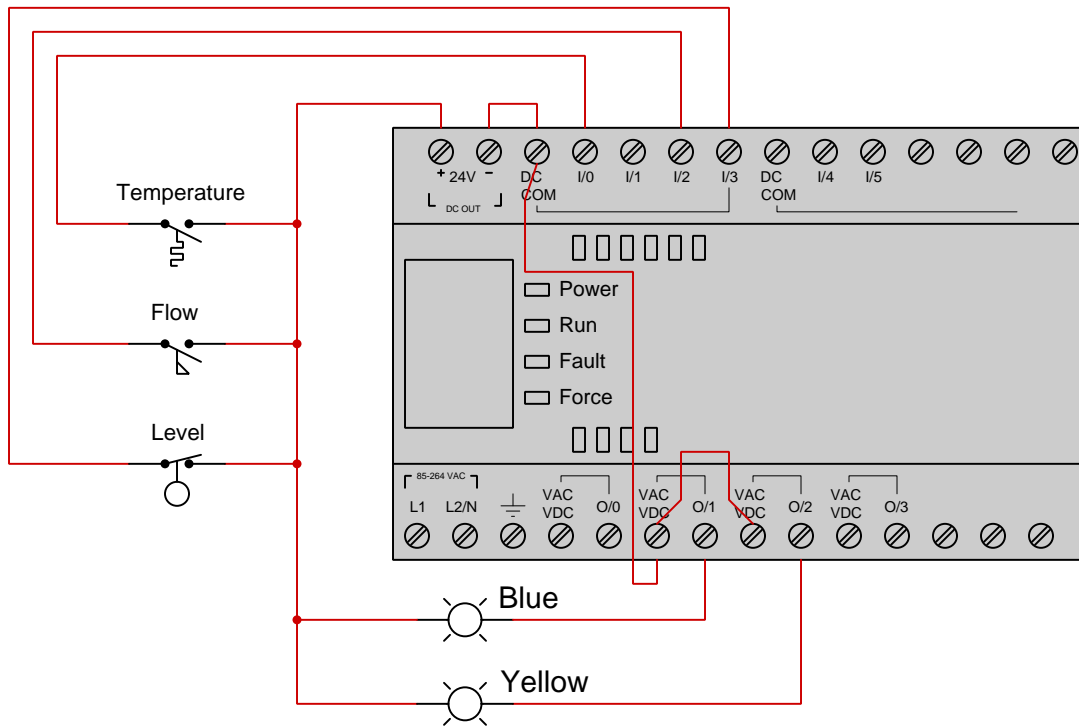

Determine the necessary switch actuation statuses (i.e. low versus high process stimulus) to turn the blue lamp on, given the following program running in the PLC:

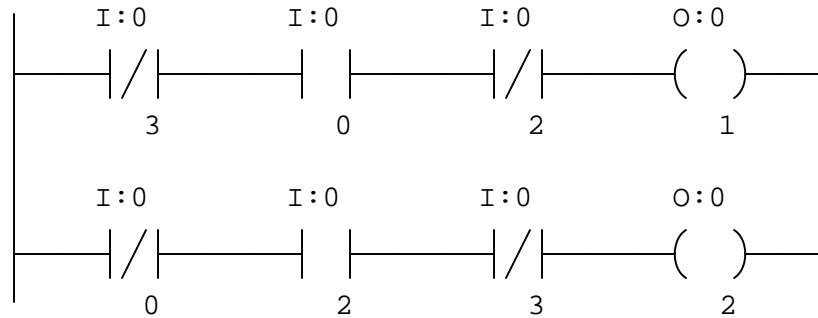

Next, determine the necessary switch actuation statuses (i.e. low versus high process stimulus) to turn the yellow lamp on, given the same PLC program.

file i02601

Question 19

Suppose we have a Koyo “CLICK” PLC connected to three pushbutton switches as shown in this illustration:

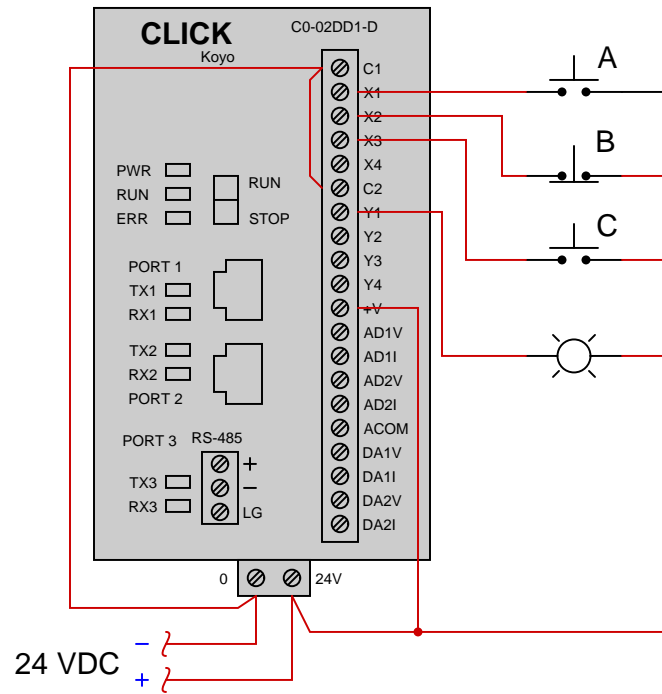

Sketch a Ladder Diagram program for this PLC to energize the lamp if the following input conditions are met:

- Switch A pressed
- Switch B pressed
- Switch C unpressed



file i02037

Question 20

Suppose we have a Koyo "CLICK" PLC connected to three pushbutton switches as shown in this illustration:

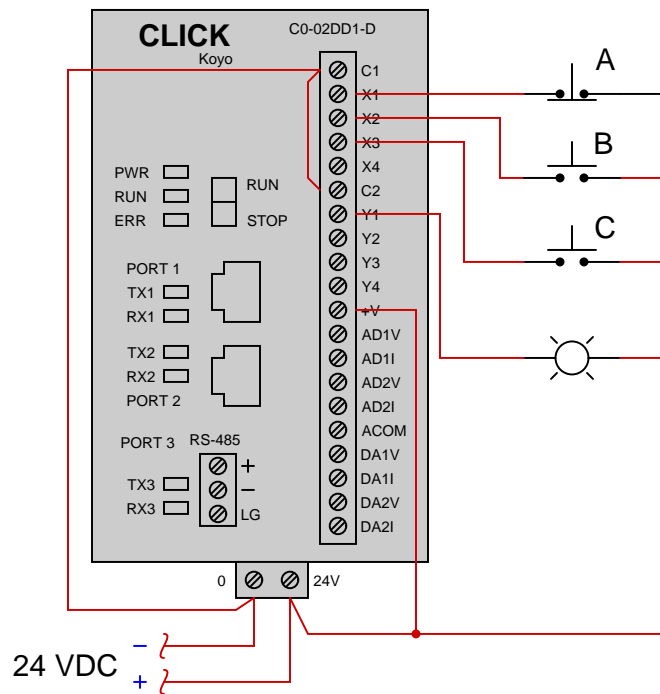

Sketch a Ladder Diagram program for this PLC to energize the lamp if the following input conditions are met:

- Either switch A or switch B pressed
- Switch C unpressed



file i02038

Question 21

Suppose we have an Allen-Bradley MicroLogix 1000 PLC and two pressure switches we need to connect to it:

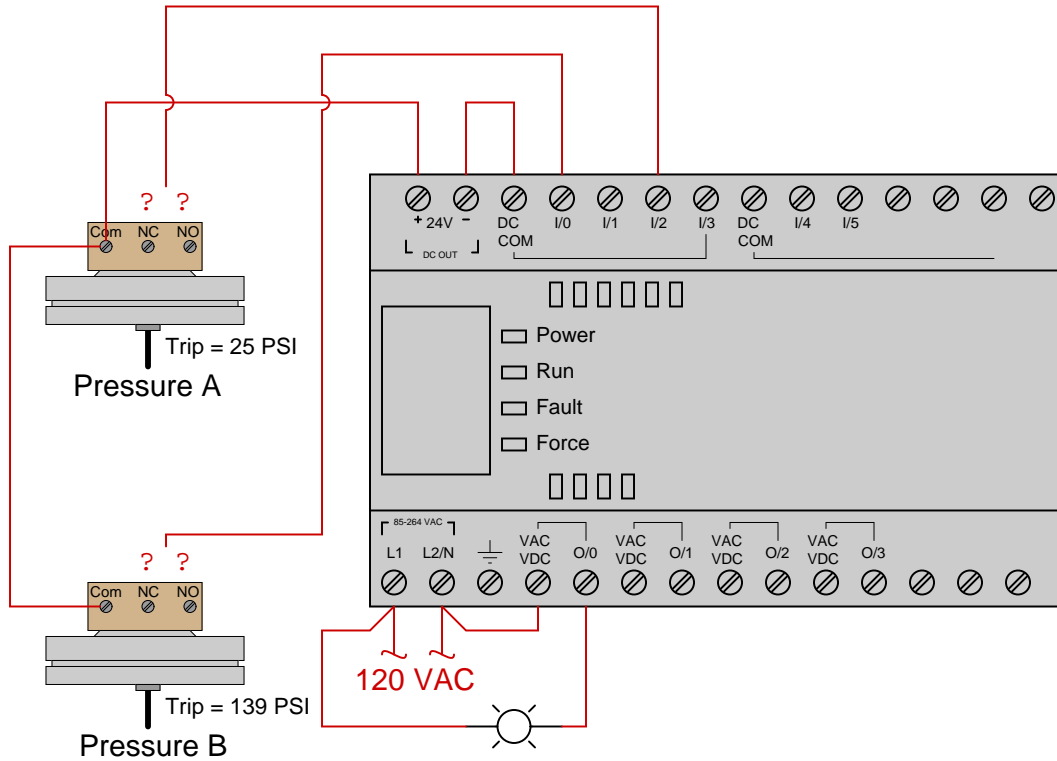

Determine the necessary contacts on each pressure switch (NO versus NC) we need to connect to the PLC inputs in order to make the lamp turn on when pressure A exceeds 25 PSI and pressure B drops below 139 PSI, given the following program running in the PLC:

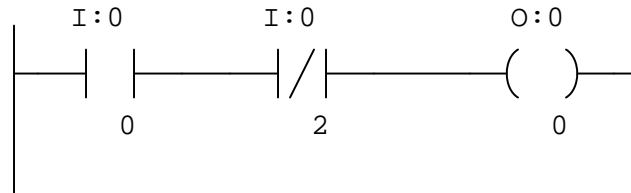

[file i04639](#)

Question 22

This PLC is being used to start and stop an electric motor, and also to shut it down automatically if any of three “shutdown” conditions occur:

- Excessive vibration
- Overcurrent (overload heater contact)
- High winding temperature

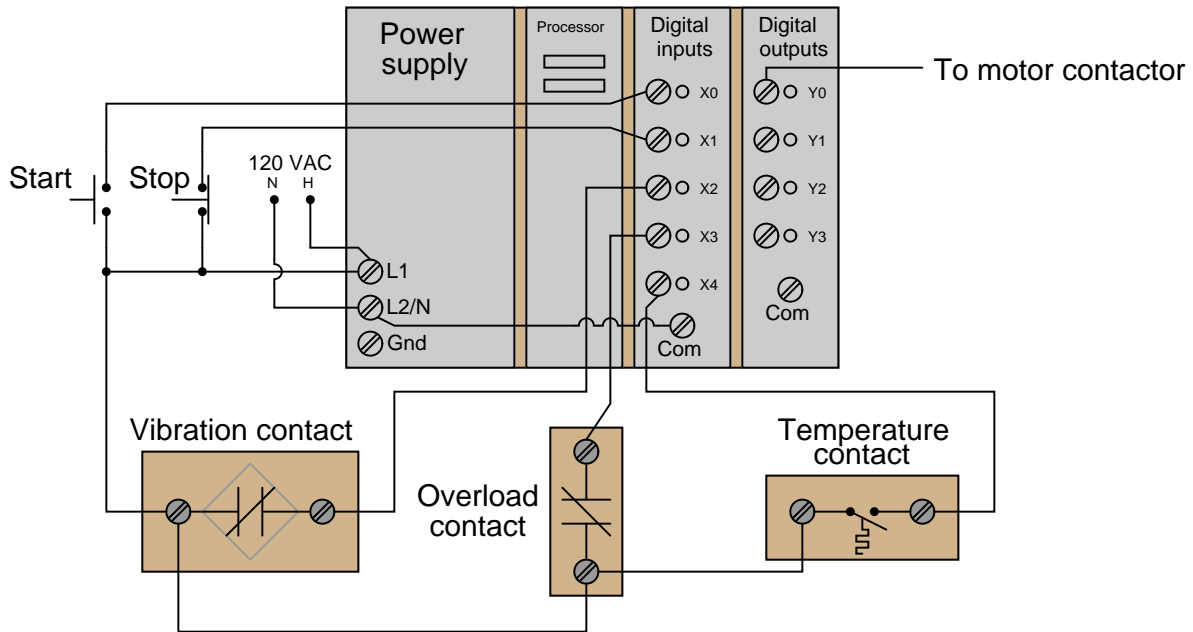

The status of each shutdown contact is as follows:

- Vibration contact: *closed* when okay, *opens* when vibration becomes excessive
- Overload contact: *closed* when okay, *opens* when overloaded
- Temperature contact: *open* when okay, *closes* when hot

Draw a PLC ladder-logic program to start and stop this motor. Be sure to make the program latching so that the operator does not have to hold the Start button to keep the motor running.

PLC program

Question 23

The following PLC program was written to control the operation of a large electric motor-driven pump. A variety of “permissive” inputs protect the pump from damage under abnormal conditions:

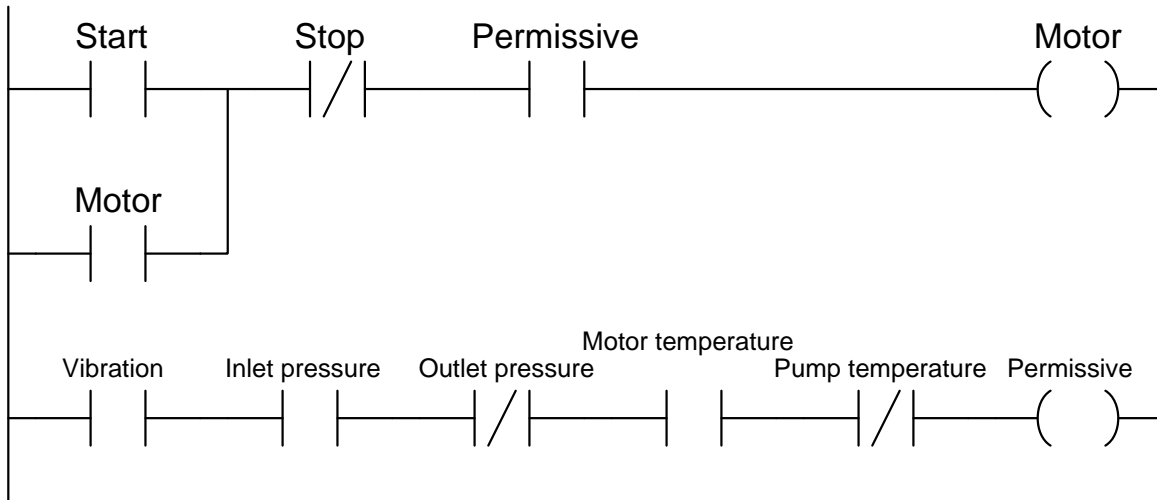

Identify the type of contact (either NO or NC) necessary for each of these electrical switch contacts, based on the trip condition (either *high* or *low*) and how each input is applied in the PLC program:

- Start pushbutton = *NO* or *NC*?
- Stop pushbutton = *NO* or *NC*?
- High vibration = *NO* or *NC*?
- Low inlet pressure = *NO* or *NC*?
- High outlet pressure = *NO* or *NC*?
- High motor temperature = *NO* or *NC*?
- High pump temperature = *NO* or *NC*?

Question 24

The following PLC program was written to control the operation of a large electric motor-driven pump. A variety of “permissive” inputs protect the pump from damage under abnormal conditions, and one permissive in particular (“valve open”) will only allow the pump to start up if one of the valves in the piping system is in the full-open position:

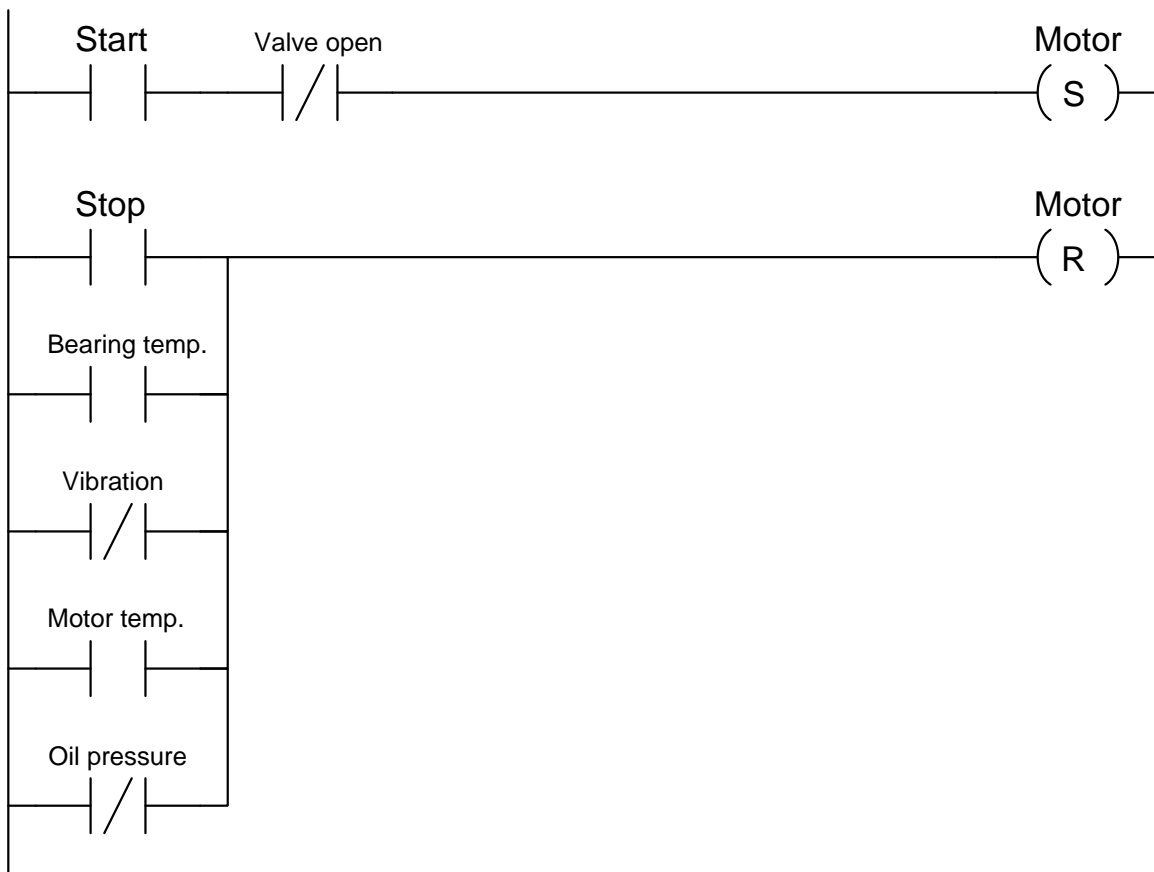

Identify the type of contact (either NO or NC) necessary for each of these electrical switch contacts, based on the trip condition (either *high* or *low*) and how each input is applied in the PLC program:

- Start pushbutton = *NO* or *NC*?
- Throttling valve open limit = *NO* or *NC*?
- Stop pushbutton = *NO* or *NC*?
- High bearing temperature = *NO* or *NC*?
- High vibration = *NO* or *NC*?
- High motor temperature = *NO* or *NC*?
- Low oil pressure = *NO* or *NC*?

[file i02561](#)

Question 25

A Koyo CLICK PLC controls the start-up of a gas-fuel furnace, using an *event drum* instruction. The purpose of this sequence is to safely “purge” the furnace of any residual fuel gas vapors using fresh air before attempting to ignite it:

Inputs

- X001 – “Purge start” pushbutton (momentary NO)
- X002 – “Ignition start” pushbutton (momentary NO)
- X003 – “Shutdown” pushbutton (momentary NO)
- X004 – Flame sensor – *PLC input energizes when flame detected*

Outputs

- Y001 – Combustion air valve – *energizing this PLC output opens the air valve to the furnace*
- Y002 – Fuel gas valve – *energizing this PLC output opens the fuel gas valve to the furnace*
- Y003 – “Purge complete” lamp
- Y004 – Spark ignition coil

Step description

- Step 1 – Waiting to purge
- Step 2 – Purging combustion chamber
- Step 3 – Chamber purged, waiting to start
- Step 4 – Furnace running

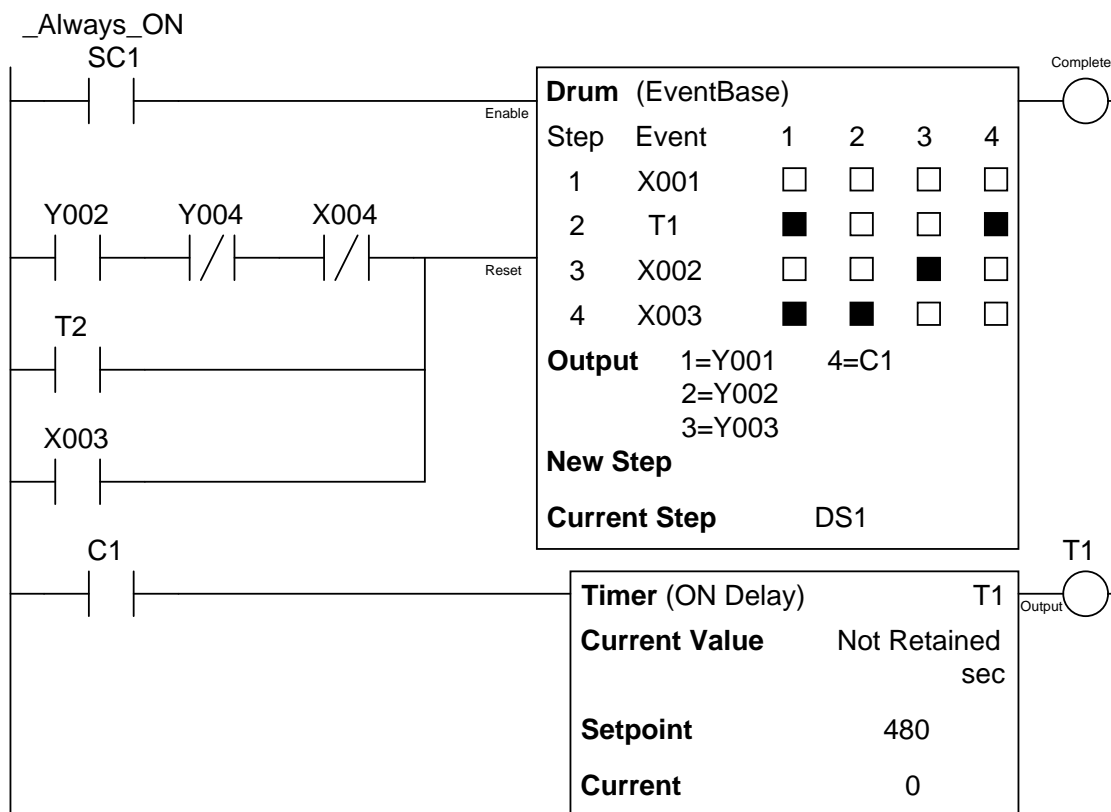

(continued on next page)

(continued from previous page)

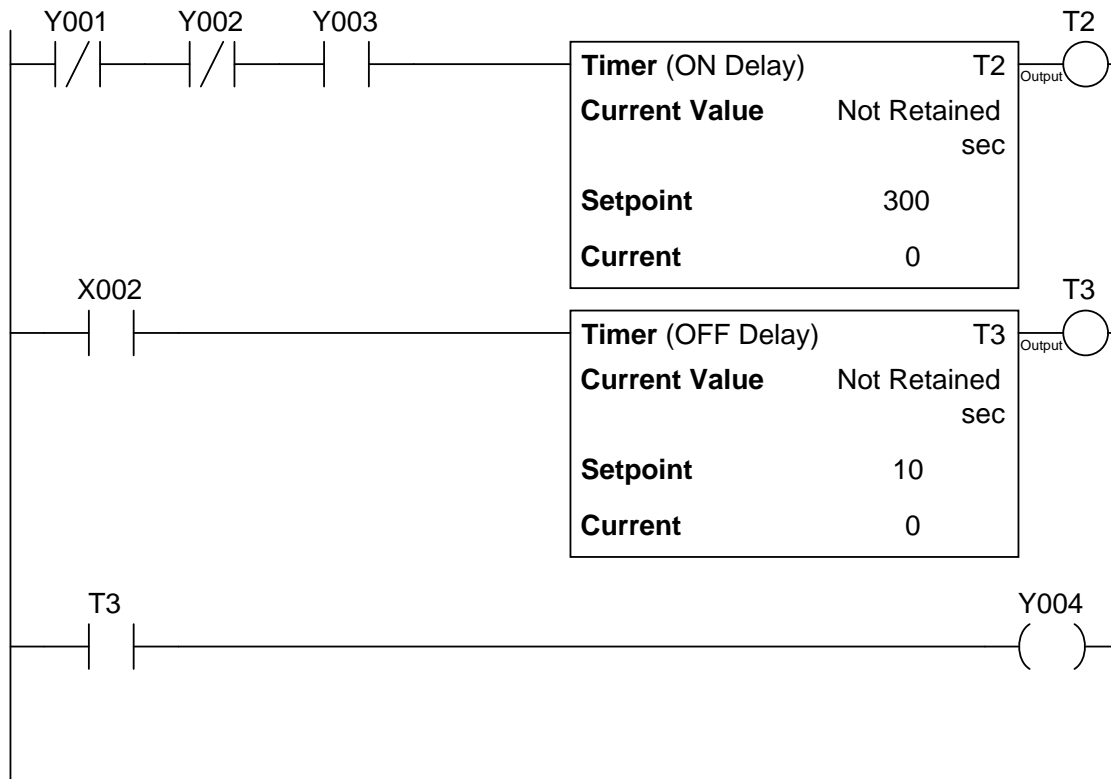

Analyze this furnace control program, and then explain what each instruction does (including the practical function of each timer instruction). Also, identify all conditions that will shut down this system (returning the drum to step 1).

Suggestions for Socratic discussion

- Why is a *purge time* so important to the safe operation of a gas fuel furnace?
- Explain the purpose of the NO contact instruction addressed to the bit `_Always_ON` (SC1).
- Suppose you were helping another technician troubleshoot a burner problem in this furnace, and in the process of doing so had to start up and shut down the furnace several times. The technician you are working with gets impatient and tells you to edit the PLC program so that he won't have to wait so long for the furnace to re-purge itself every start-up cycle. Which portion of the program controls the purge time? Would you do what the other technician tells you to do? Why or why not?
- Suppose the programmer writing this program forgot to include the normally-open Y002 contact in the rung leading to the drum instruction's *reset* input. How would this omission affect the program's operation?
- Suppose the programmer writing this program forgot to include the normally-closed Y004 contact in the rung leading to the drum instruction's *reset* input. How would this omission affect the program's operation?

[file i00458](#)

Answers

Answer 1

Switch statuses:

- Switch A = **pressed**
- Switch B = **released**
- Switch C = **released**

The lamp will be de-energized.

Answer 2

High pressure *and* **low** flow *and* **low** temperature.

The lamp will be de-energized.

Answer 3

High pressure *and* **low** flow *and* **high** temperature.

The lamp will be de-energized.

Answer 4

High pressure *and* **high** flow *and* **low** temperature.

The lamp will be energized.

Answer 5

Low level *and* **low** flow *and* **low** temperature.

The lamp will be energized.

Answer 6

Low level *and* **high** flow *and* **high** temperature.

The lamp will be de-energized.

Answer 7

Necessary switch statuses:

- Switch A = **released**
 - Switch B = **released**
 - Switch C = **pressed**
-

Answer 8

Necessary switch statuses:

- Switch A = **pressed**
 - Switch B = **pressed**
 - Switch C = **released**
-

Answer 9

To energize lamp Z: **press** switch B, **release** switch A.

To energize lamp Y: **press** switch A, **release** switch B.

Answer 10

Output Q0.1 will activate to energize lamp Y, but the other output (and lamp) will remain off.

Answer 11

Output Q0.1 will activate to energize lamp Y, but the other output (and lamp) will remain off.

To energize lamp Z, you must release (unpress) both switches.

Answer 12

- Contactor coil failed open
 - Wire connecting contactor coil to 0:0/2 failed open
 - Wire connecting VAC-VDC terminal to DC COM terminal failed open
 - Wire connecting input switch “commons” to contactor coil failed open
 - Output channel 0:0/2 defective on the PLC
 - 24 VDC power supply in the PLC is insufficient to power the contactor’s coil
-

Answer 13

Green lamp is on, red lamp is off.

Answer 14

Green lamp is off, red lamp is on. The PLC inputs are configured here to *sink* current.

Answer 15

The blue lamp will be **off** and the yellow lamp will be **on**.

Answer 16

Switch A = **pressed**

Switch B = **released**

Switch C = **pressed**

Answer 17

Low temperature *and* **low** flow *and* **low** level are required to energize the yellow lamp.

High temperature *and* **high** flow *and* **high** level are required to energize the blue lamp.

Answer 18

High temperature *and* **low** flow *and* **high** level are required to energize the blue lamp.

Low temperature *and* **high** flow *and* **high** level are required to energize the yellow lamp.

Answer 19

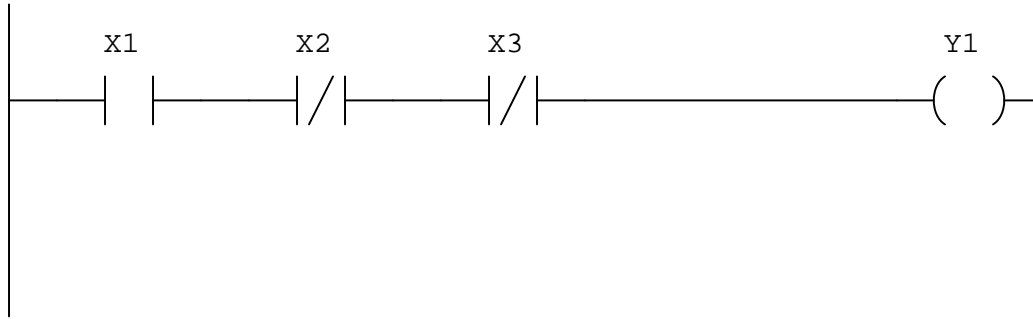

Answer 20

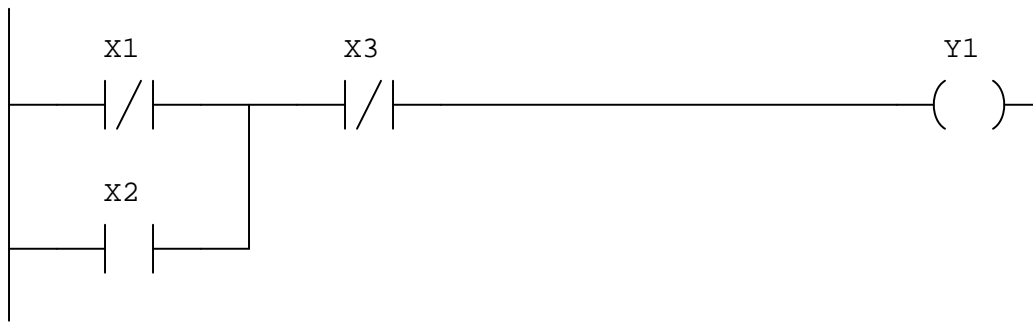

Answer 21

Both pressure switches need their *normally-closed* (NC) contact terminals connected to the respective PLC input terminals.

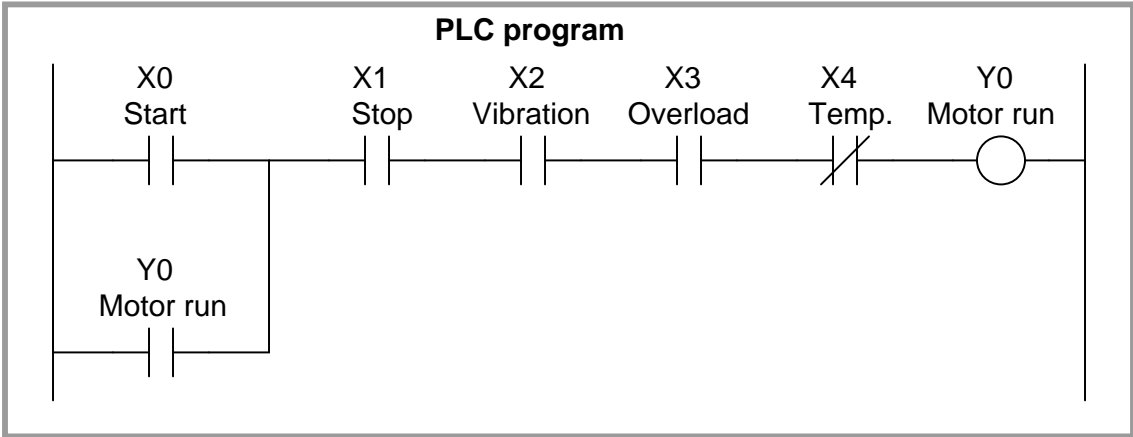

- Start pushbutton = **NO**
- Stop pushbutton = **NO**
- High vibration = **NC**
- Low inlet pressure = **NO**
- High outlet pressure = **NO**
- High motor temperature = **NC**
- High pump temperature = **NO**

A helpful problem-solving technique is to first identify the necessary *coloring* which will allow the motor to run (i.e. the condition of all permissives during correct operating conditions):

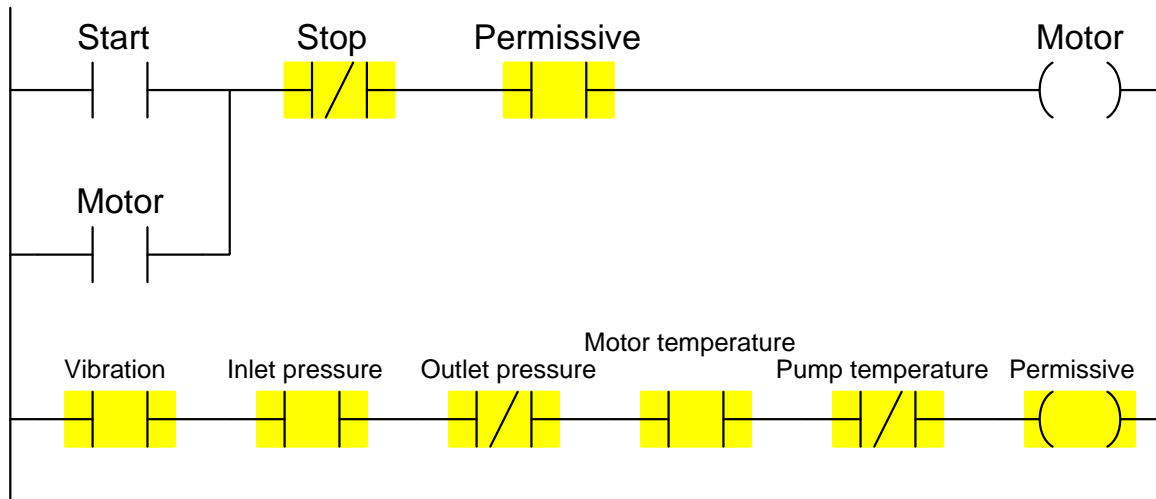

We know the NO contact instruction labeled “Permissive” in the upper rung needs to be colored if ever the “Motor” coil instruction is to receive color. This means the entire series string of contact instructions in the second rung needs to be colored under proper operating conditions.

Once we know this, we may determine the necessary “normal” statuses of all permissive switches in order to make their corresponding PLC program contact instructions colored. A few examples will be given here:

High vibration: The PLC contact instruction for this permissive is normally-open, which means that PLC input must be energized with electricity in order to color that contact instruction. This means the high vibration switch must be in the closed condition while everything is running as it should (i.e. low vibration), and open if vibration becomes excessive. A vibration switch that is closed when vibration is below the trip threshold is a **normally-closed (NC)** vibration switch.

Low inlet pressure: The PLC contact instruction for this permissive is normally-open, which means that PLC input must be energized with electricity in order to color that contact instruction. This means the low inlet pressure switch must be in the closed condition while everything is running as it should (i.e. adequate inlet pressure), and open if inlet pressure becomes too low. A pressure switch that is open when pressure is below the trip threshold is a **normally-open (NO)** pressure switch.

High outlet pressure: The PLC contact instruction for this permissive is normally-closed, which means that PLC input must be de-energized in order to color that contact instruction. This means the high outlet pressure switch must be in the open condition while everything is running as it should (i.e. moderate outlet

pressure), and close if outlet pressure becomes excessive. A pressure switch that is open when pressure is below the trip threshold is a **normally-open (NO)** pressure switch.

- Start pushbutton = **NO**
- Throttling valve open limit = **NC**
- Stop pushbutton = **NO**
- High bearing temperature = **NO**
- High vibration = **NC**
- High motor temperature = **NO**
- Low oil pressure = **NO**

A helpful problem-solving technique is to first identify the necessary *coloring* which will allow the motor to start up and keep running (i.e. the condition of all permissives during correct operating conditions):

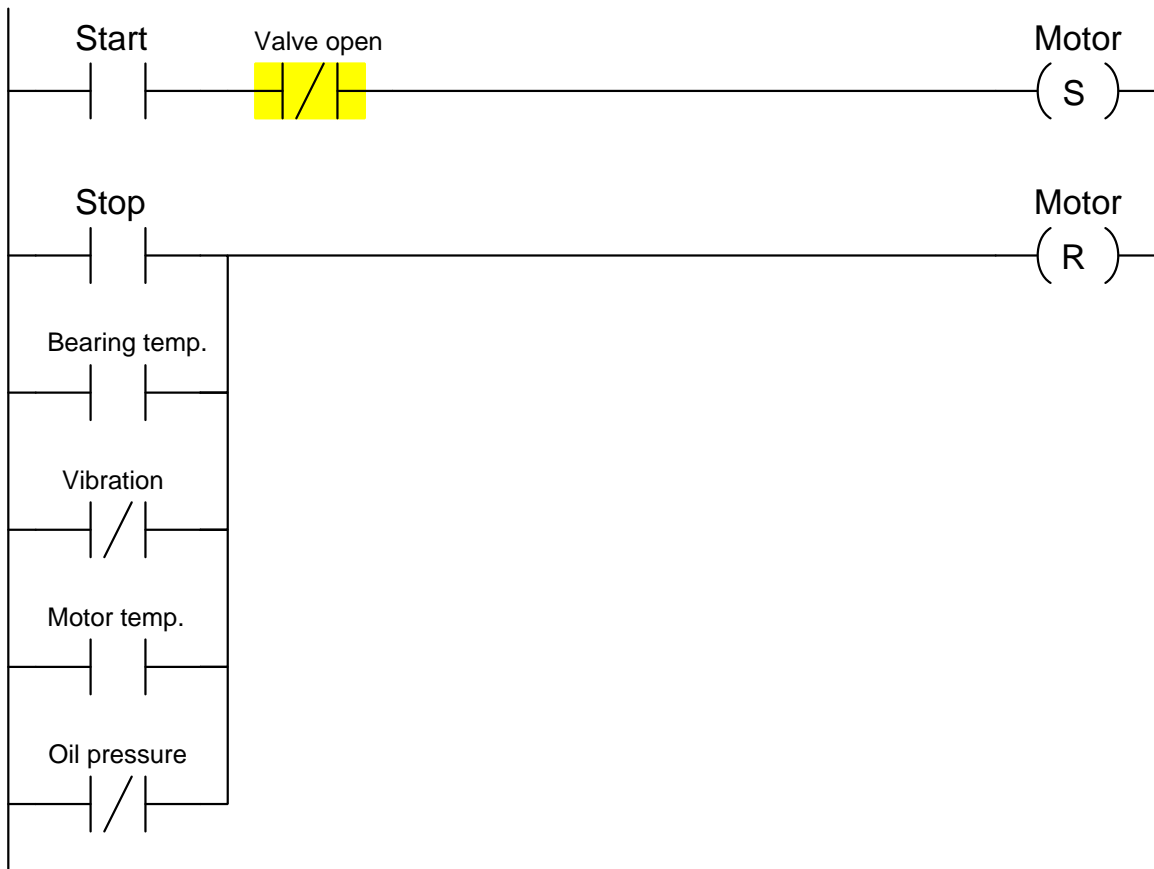

Since the motor is controlled by retentive coil instructions (“Set” and “Reset”), we know all the permissive contacts on the Reset rung must be uncolored in order for the motor to run. The normally-closed “Valve open” instruction must be colored in order to allow the Start input to latch the Set coil and start the motor.

Once we know this, we may determine the necessary “normal” statuses of all permissive switches in order to make their corresponding PLC program contact instructions colored. A few examples will be given here:

“Valve open” limit switch: The PLC contact instruction for this permissive is normally-closed, which means that PLC input must be de-energized in order to color that contact instruction. This means the limit

switch must be in the open condition when the valve mechanism moves into the switch's sensing range (in the fully-open position), and close when the valve mechanism moves away from the switch. A limit switch that is closed with nothing near it is a **normally-closed (NC)** limit switch.

Low oil pressure: The PLC contact instruction for this permissive is normally-closed, which means that PLC input must be energized with electricity in order to maintain that contact instruction in an uncolored state. This means the low oil pressure switch must be in the closed condition while everything is running as it should (i.e. adequate oil pressure), and open if oil pressure becomes too low. A pressure switch that is open when pressure is below the trip threshold is a **normally-open (NO)** pressure switch.

High bearing temperature: The PLC contact instruction for this permissive is normally-open, which means that PLC input must be de-energized in order to maintain that contact instruction in an uncolored state. This means the high bearing temperature switch must be in the open condition while everything is running as it should (i.e. low bearing temperature), and close if temperature becomes excessive. A temperature switch that is open when temperature is below the trip threshold is a **normally-open (NO)** temperature switch.

Answer 25