

Three-phase AC circuits

This worksheet and all related files are licensed under the Creative Commons Attribution License, version 1.0. To view a copy of this license, visit <http://creativecommons.org/licenses/by/1.0/>, or send a letter to Creative Commons, 559 Nathan Abbott Way, Stanford, California 94305, USA. The terms and conditions of this license allow for free copying, distribution, and/or modification of all licensed works by the general public.

Questions

Question 1

AC electric generators (sometimes called *alternators*) work on the principle of electromagnetic induction, spinning a magnet between wire coils as such:

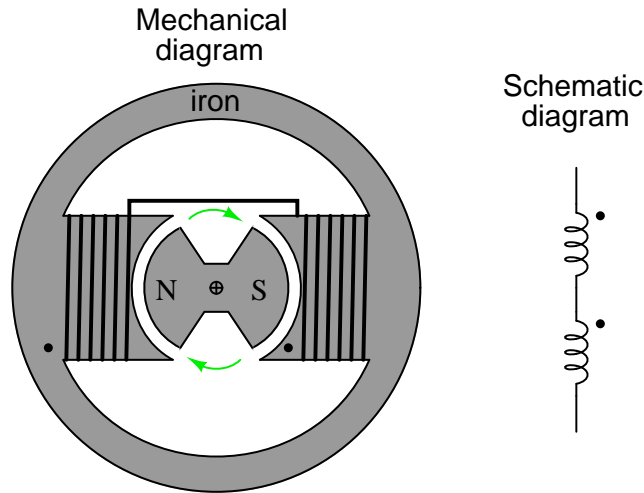

These wire coils typically exist in pairs opposite each other from the centerline of the rotor shaft. The wire coils are called *stator coils* or *stator windings*, because they are stationary. This particular machine is called a *single-phase* alternator because the stator coils act as a single unit, producing one sine-wave AC voltage as the magnetized rotor turns.

A *three-phase* AC generator has three sets of stator coils arranged 120° apart from each other around the centerline of the rotor shaft:

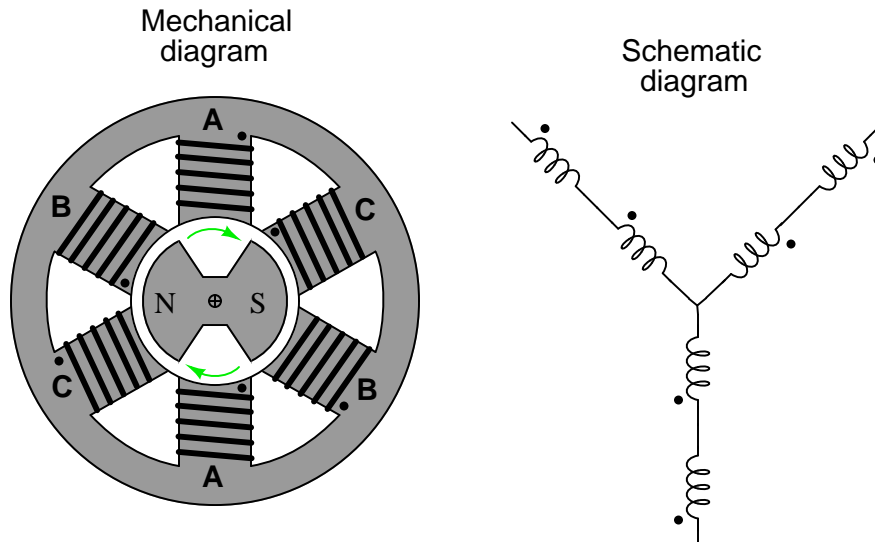

Since the three pairs of stator windings “see” the poles of the magnetized rotor pass by at different times, their respective sine-wave voltages will be out of step (out of phase) with each other.

The following graph shows the pattern of the AC voltage produced by the first alternator (single-phase), with only one stator coil pair, as the rotor makes two complete rotations (from 0° to 360° , twice):

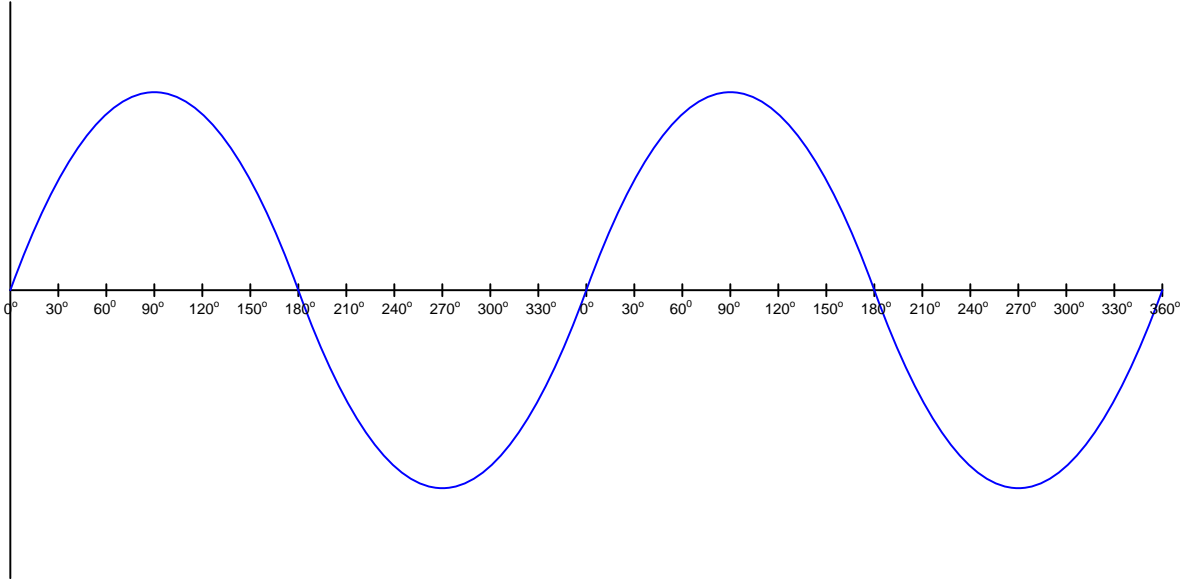

Sketch the patterns of the two additional AC voltages produced by the three-phase alternator on this same graph, and comment on the phase relationship between the three AC voltage waveforms.
[file i03256](#)

Question 2

Suppose a set of three neon light bulbs were connected to a 3-phase alternator with the three stator winding sets labeled **A**, **B**, and **C**:

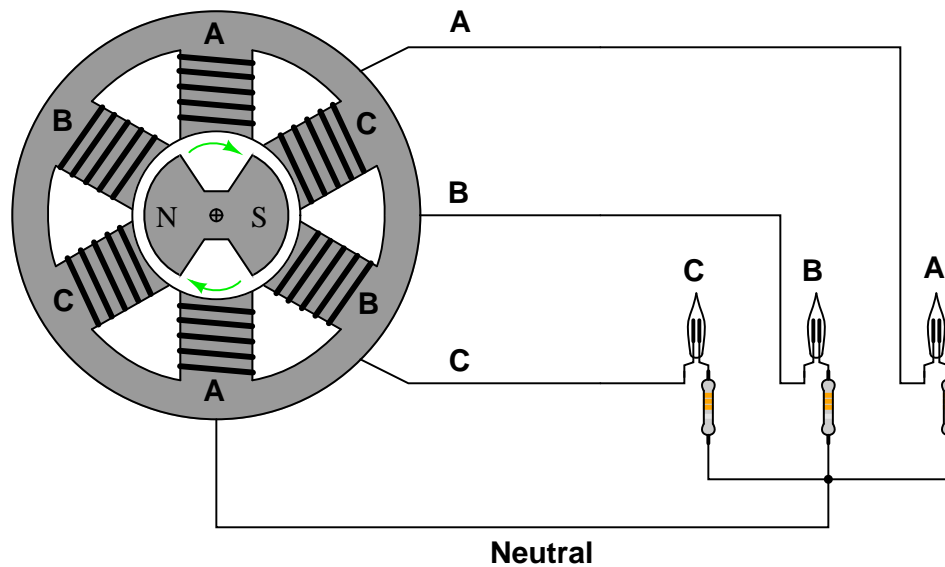

The schematic diagram for this alternator/lamp system is as follows:

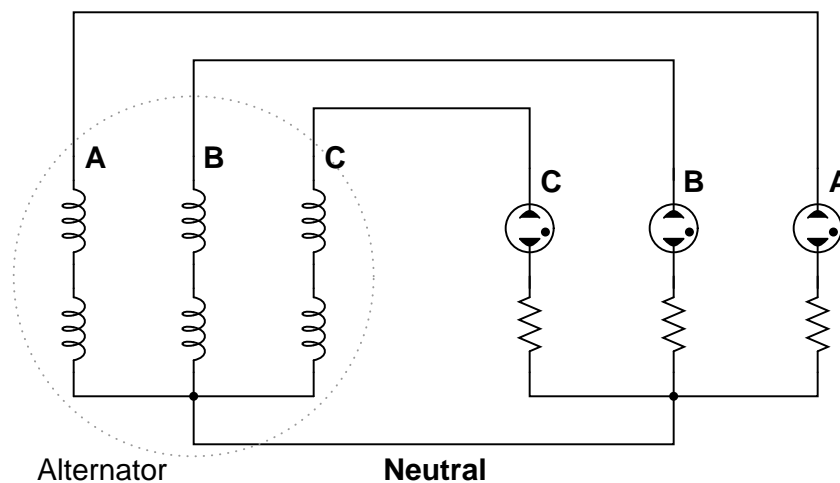

If the alternator spins fast enough (clockwise, as shown), the AC voltage induced in its windings will be enough to cause the neon lamps to “blink” on and off. Most likely this blinking will be too fast to discern with the naked eye.

However, if we were to video-record the blinking and play back the recording at a slow speed, we should be able to see the sequence of light flashes. Determine the apparent “direction” of the lamps’ blinking (from right-to-left or from left-to-right), and relate that sequence to the voltage peaks of each alternator coil pair.

Furthermore, determine how to reverse the blinking sequence just by reconnecting wires between the alternator and the neon lamps.

[file i03257](#)

Question 3

Three-phase motors and generators alike are manufactured in two basic forms: *Wye* (Y) and *Delta* (Δ):

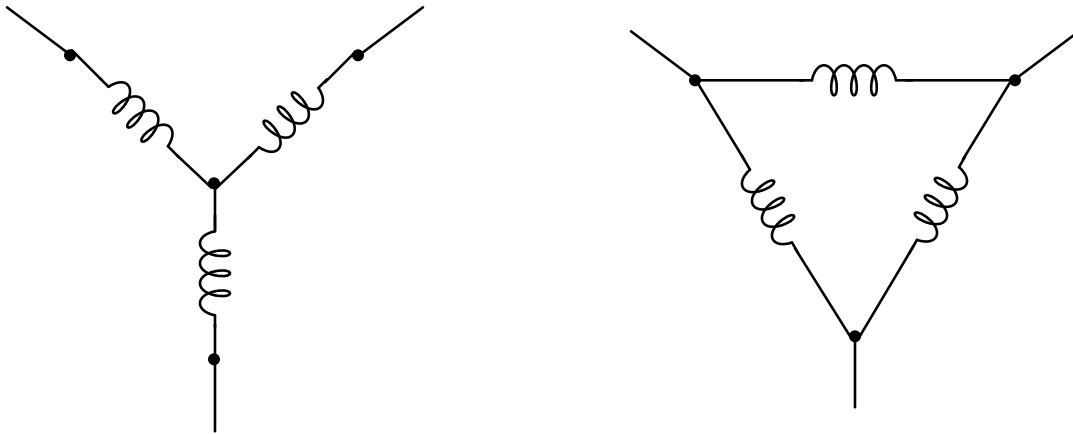

Mark in the above diagrams where the following electrical quantities would be measured (hint: each coil shown in the diagram is called a *phase* winding, and each conductor connecting the motor or generator to something else in the three-phase system is called a *line*):

- Phase voltage
- Line voltage
- Phase current
- Line current

In which circuit (Wye or Delta) are the phase and line currents equal? In which circuit (Wye or Delta) are the phase and line voltages equal? Explain both answers, in terms that anyone with a basic knowledge of electricity could understand (i.e. using the properties of *series* and *parallel* connections). Where phase and line quantities are *unequal*, determine which is larger.

[file i03258](#)

Question 4

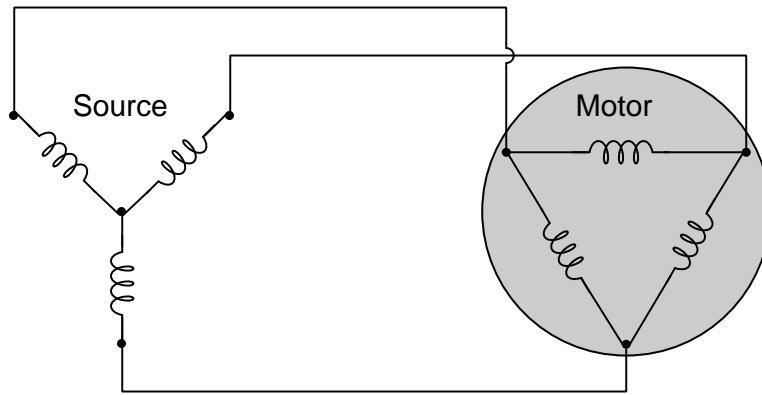

Identify points within this circuit absolutely guaranteed to share the same current, whether or not the source or load happen to be balanced.

Identify point-pairs within this circuit absolutely guaranteed to share the same voltage between them, whether or not the source or load happen to be balanced.

Now suppose one of the windings inside the motor fails open. Answer both of the above questions for this new (faulted) scenario:

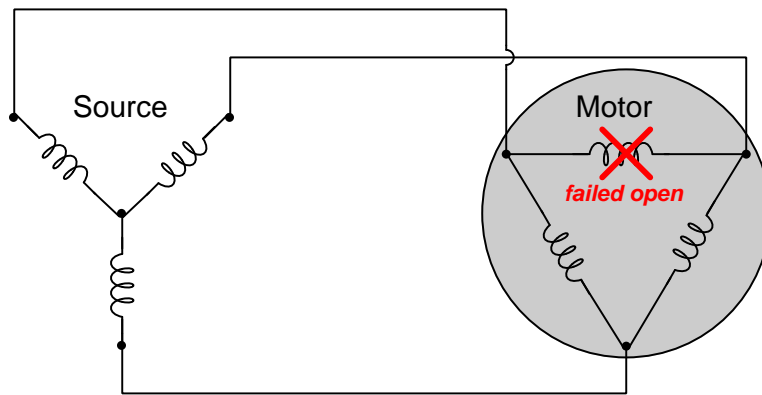

file i04458

Question 5

In this Y-Y system, the source outputs balanced voltages (i.e. all line voltages are 480 VAC, shifted 120° from each other) but the load is imbalanced:

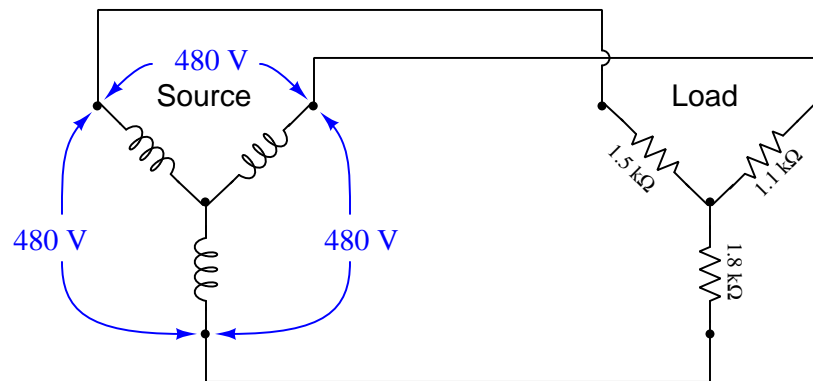

Identify points within this circuit absolutely guaranteed to share the same current, despite the imbalanced load.

Identify pairs of points within this circuit absolutely guaranteed to share the same voltage, despite the imbalanced load.

Now suppose the centers of the wye source and wye load were connected together to form a 4-wire three-phase circuit. Determine the amount of voltage between each terminal of the wye-connected source and earth ground.

[file i04726](#)

Question 6

Calculate the amount of current passing through each of the phase windings of this 100 horsepower electric motor while operating at full load, assuming a line voltage of 460 volts, 100% motor efficiency, and a power factor of 1:

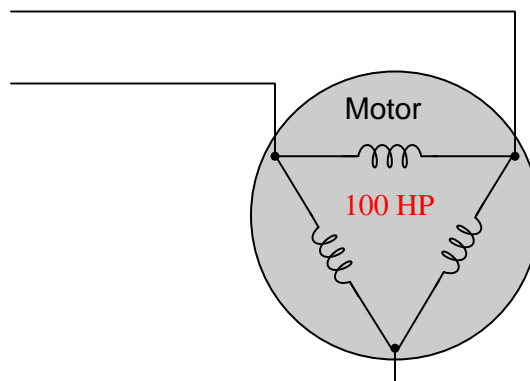

$I_{phase} = \underline{\hspace{2cm}}$

[file i01297](#)

Question 7

Predict the amount of AC voltage between the following test points and earth ground in this wye-connected AC generator given the specified switch states. Assume that this generator is designed to have a (balanced) phase voltage of 120 volts AC:

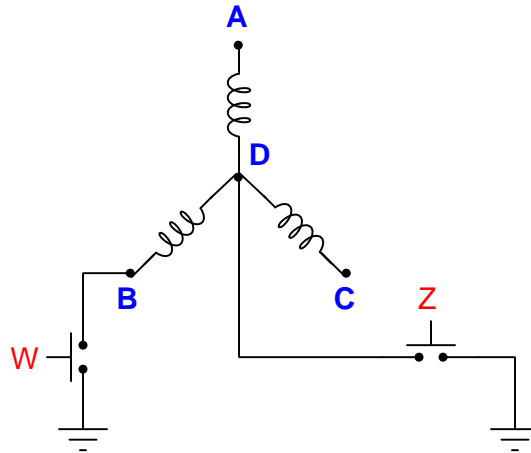

(Switch W pressed ; switch Z unpressed)

- $V_A =$ _____ volts AC
- $V_B =$ _____ volts AC
- $V_C =$ _____ volts AC
- $V_D =$ _____ volts AC

(Switch W unpressed ; switch Z pressed)

- $V_A =$ _____ volts AC
- $V_B =$ _____ volts AC
- $V_C =$ _____ volts AC
- $V_D =$ _____ volts AC

Lastly, explain what would happen if both pushbutton switches were pressed simultaneously.

[file i03799](#)

Question 8

Predict the amount of AC voltage between the following test points and earth ground in this delta-connected AC generator given the specified switch states. Assume that this generator is designed to have a (balanced) phase voltage of 120 volts AC:

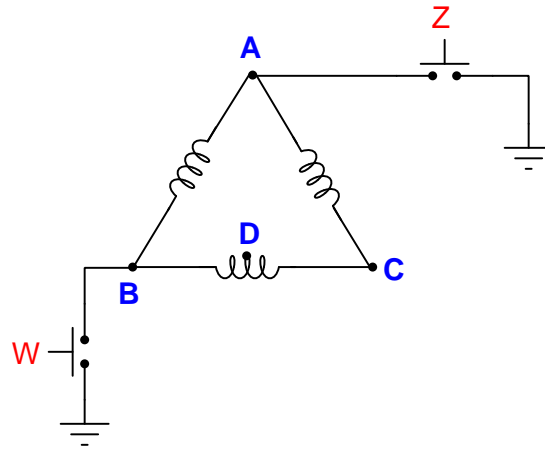

(Switch W pressed ; switch Z unpressed)

- $V_A =$ _____ volts AC
- $V_B =$ _____ volts AC
- $V_C =$ _____ volts AC
- $V_D =$ _____ volts AC

(Switch W unpressed ; switch Z pressed)

- $V_A =$ _____ volts AC
- $V_B =$ _____ volts AC
- $V_C =$ _____ volts AC
- $V_D =$ _____ volts AC

Lastly, explain what would happen if both pushbutton switches were pressed simultaneously.

[file i03534](#)

Question 9

Calculate the following circuit values, assuming a balanced three-phase system:

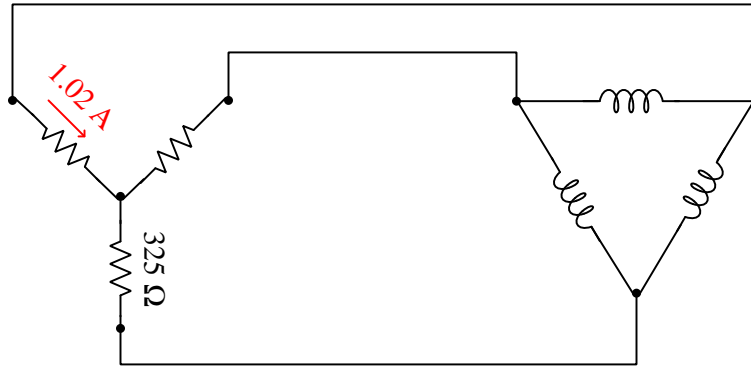

- V_{phase} (source) = _____
- I_{phase} (source) = _____
- V_{phase} (load) = _____
- I_{phase} (load) = _____
- V_{line} = _____
- I_{line} = _____
- P_{total} = _____

file i01193

Question 10

Calculate the following circuit values, assuming a balanced three-phase system:

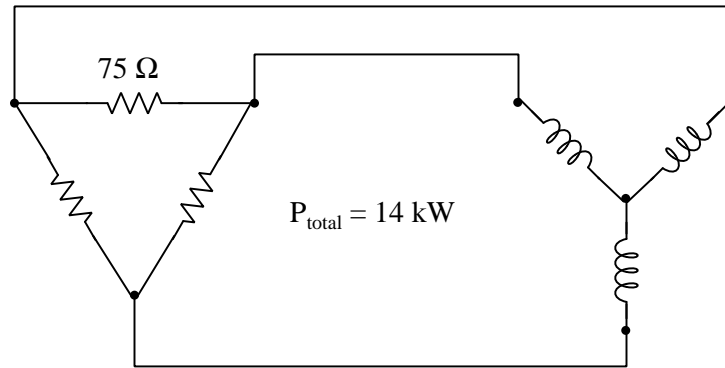

- V_{phase} (source) = _____
- I_{phase} (source) = _____
- V_{phase} (load) = _____
- I_{phase} (load) = _____
- V_{line} = _____
- I_{line} = _____

[file i01623](#)

Question 11

Suppose you need to design a three-phase electric heater to dissipate 15 kW of heat when powered by 480 VAC. Your options are to build a delta-connected heater array or a wye-connected heater array:

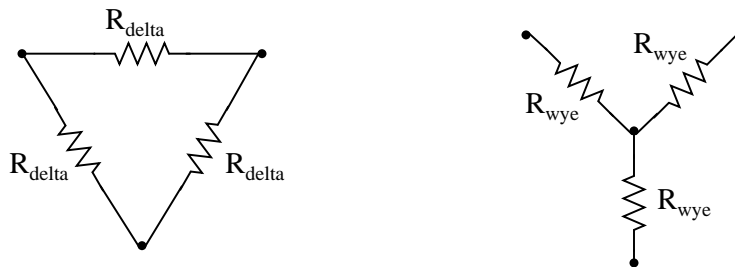

Calculate the proper resistance value for each array, to achieve the desired heat output:

$$R_{\text{delta}} = \text{_____ } \Omega$$

$$R_{\text{wye}} = \text{_____ } \Omega$$

[file i01040](#)

Question 12

A three-phase electric motor operating at a line voltage of 4160 volts AC (RMS) draws 27.5 amps of current (RMS) through each of its lines. Calculate the amount of electrical power consumed by this motor.

Assuming the motor is 92% efficient and operating at a power factor of 1, calculate its mechanical output power in the unit of horsepower.

[file i01206](#)

Question 13

Calculate the full-load line current for a three-phase motor, given a horsepower rating of 150 HP, an efficiency of 93%, and a line voltage of 480 volts. Provide one answer for full-load line current assuming perfect power factor (1), and another answer for full-load line current assuming a power factor of 0.90.

[file i02293](#)

Question 14

Suppose the current through each of the ammeters is 2.81 amps, and the ratio of each current transformer is 100:5. Calculate the horsepower output of this AC motor, assuming a power factor of 1 and an efficiency of 88%:

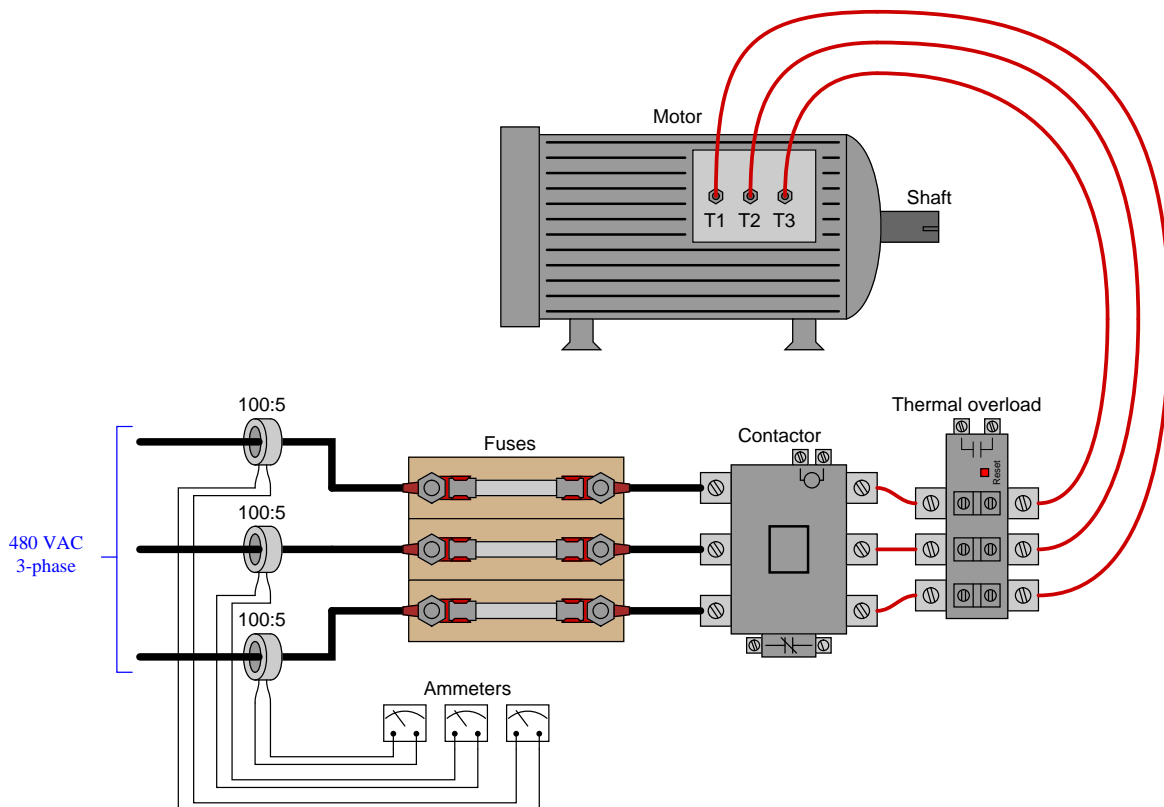

$P =$ _____ horsepower

[file i01045](#)

Question 15

Examine the primary and secondary connections on this three-phase transformer bank, and then determine the line voltage to the customer, assuming 12.5 kV line voltage on the distribution power lines. The schematic diagram shown in the grey box is typical for each of the three transformers:

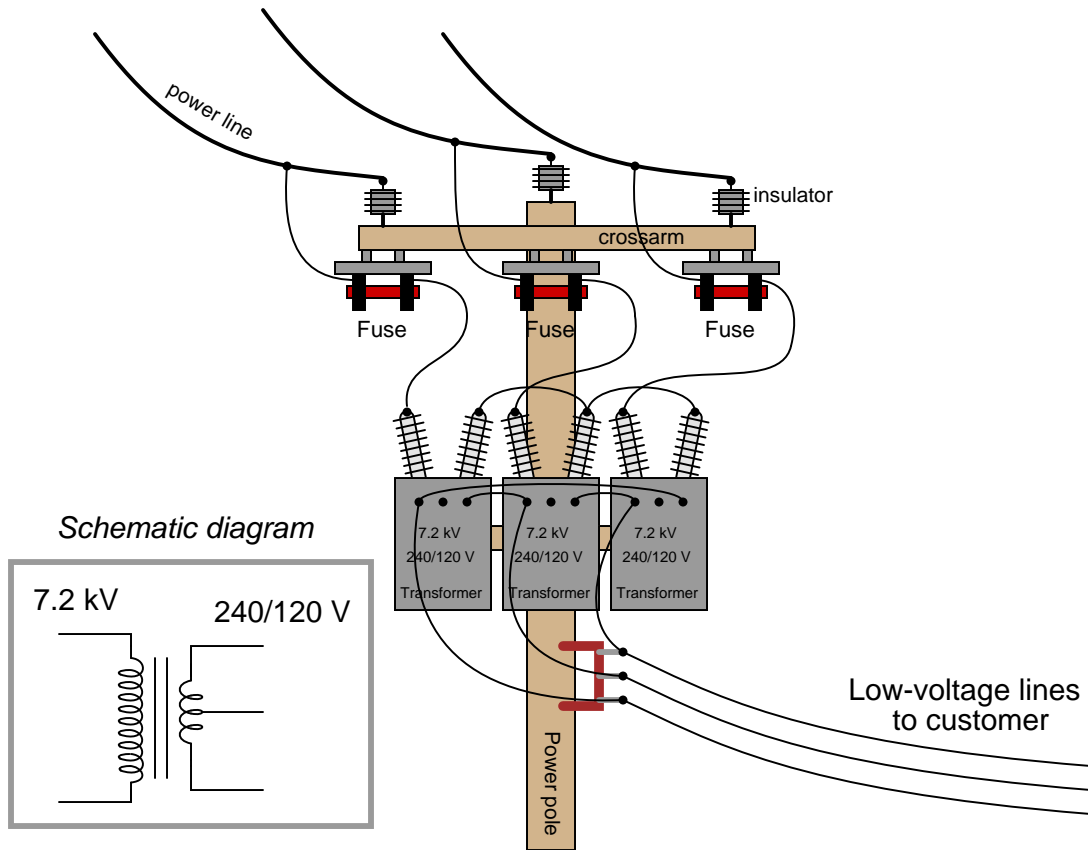

[file i01041](#)

Question 16

Three step-down transformers have their primary (high-voltage) terminals connected together in a “wye” configuration so that the 12.5 kV line voltage energizes each primary winding with 7.2 kV. The secondary terminals on each transformer have been left disconnected:

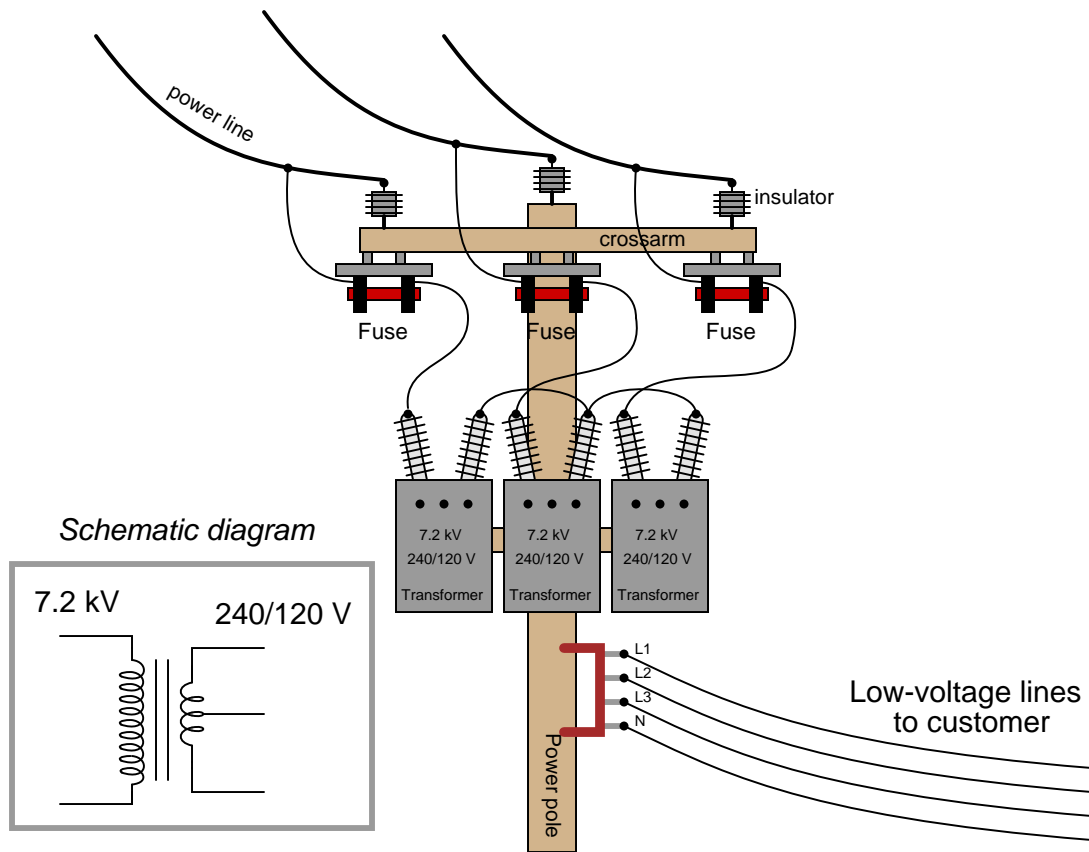

Sketch proper wire connections to provide 120/208 VAC to the customer.

[file i01042](#)

Question 17

Calculate the operating current through each of the load resistances shown in this circuit (assuming each three-phase load is balanced):

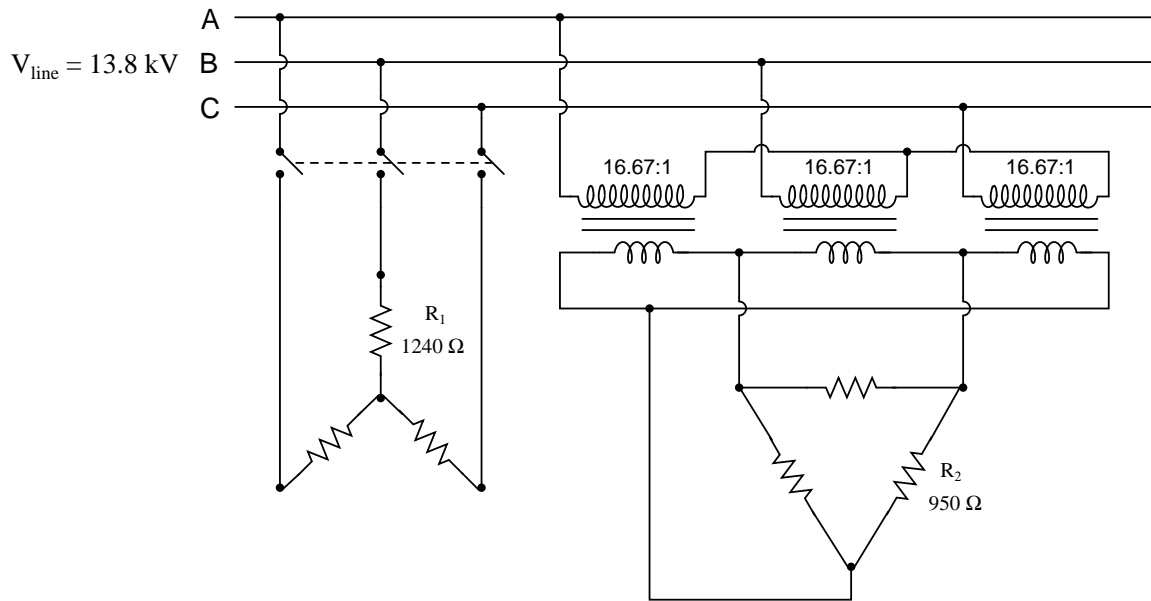

Also, calculate the power dissipated by each load.
[file i02119](#)

Question 18

An *unbalanced* wye-connected load receives power from a balanced 120/208 VAC source:

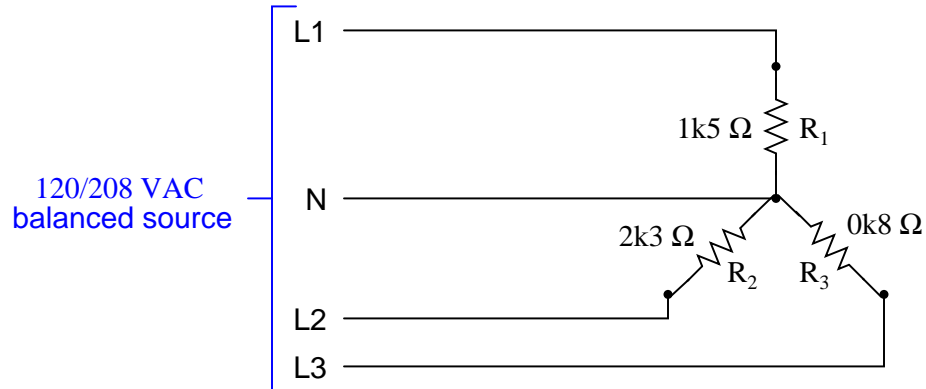

Calculate the current through each of the three lines (L1, L2, and L3), as well as the current through the neutral conductor:

- $I_{L1} =$ _____ amps
- $I_{L2} =$ _____ amps
- $I_{L3} =$ _____ amps
- $I_N =$ _____ amps

[file i01044](#)

Question 19

Three-phase AC induction motors respond differently to the loss of one phase winding, depending on whether they are internally wye- or delta-connected:

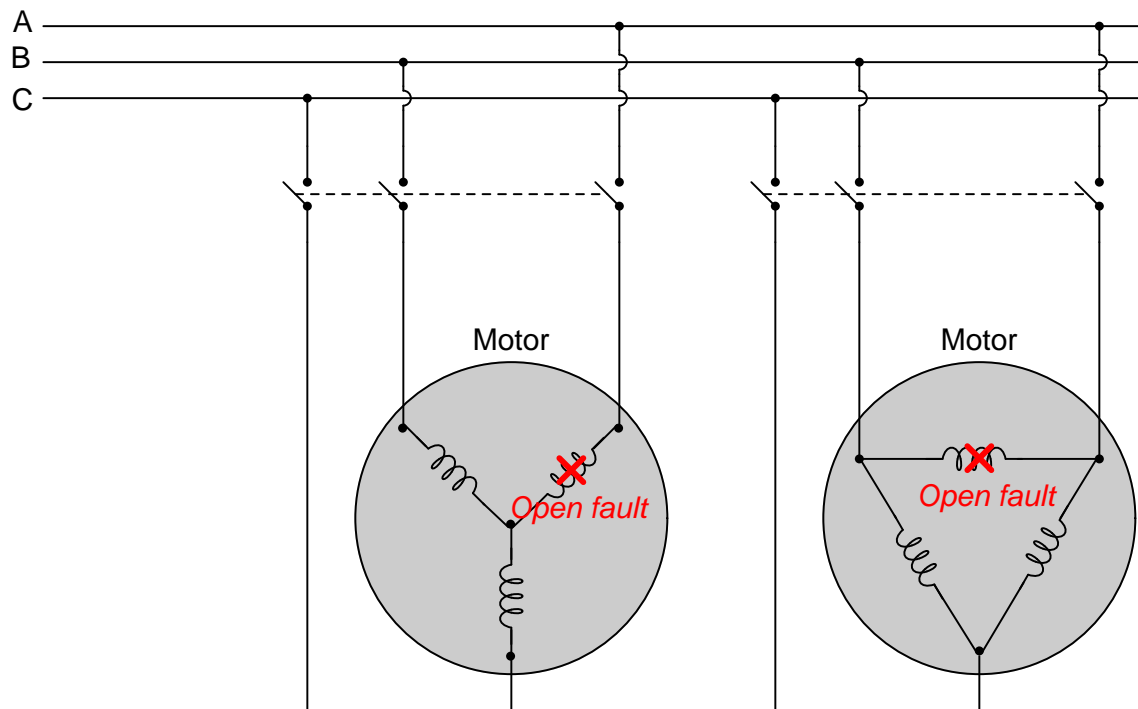

Which of these two motor designs will fare better in the event of an open fault in one phase winding, and why?

[file i00967](#)

Question 20

Calculate the mechanical power output by an electric motor (in units of horsepower) as it delivers 1250 lb-ft of torque at 850 RPM. Then, calculate the line current for this motor if it is a 3-phase unit operating at a line voltage of 480 volts. Assume 92% efficiency for the motor.

Suggestions for Socratic discussion

- How might the results differ if the motor were 100% efficient instead of 92% efficient?
- Explain how you may double-check your quantitative answer(s) with a high degree of confidence (i.e. something more rigorous than simply re-working the problem again in the same way).
- Suppose we were to alter this problem to describe a diesel engine turning a three-phase *generator* with an efficiency of 92%, at 1250 lb-ft of torque and a shaft speed of 850 RPM. At a line voltage of 480 volts, how much line current could we expect the generator to output? Is the answer the same as in the case of the motor? Explain why or why not.

[file i01434](#)

Answers

Answer 1

The three waves are phase-shifted 120° apart from each other, just as the three stator windings are arranged 120° apart from each other around the circle:

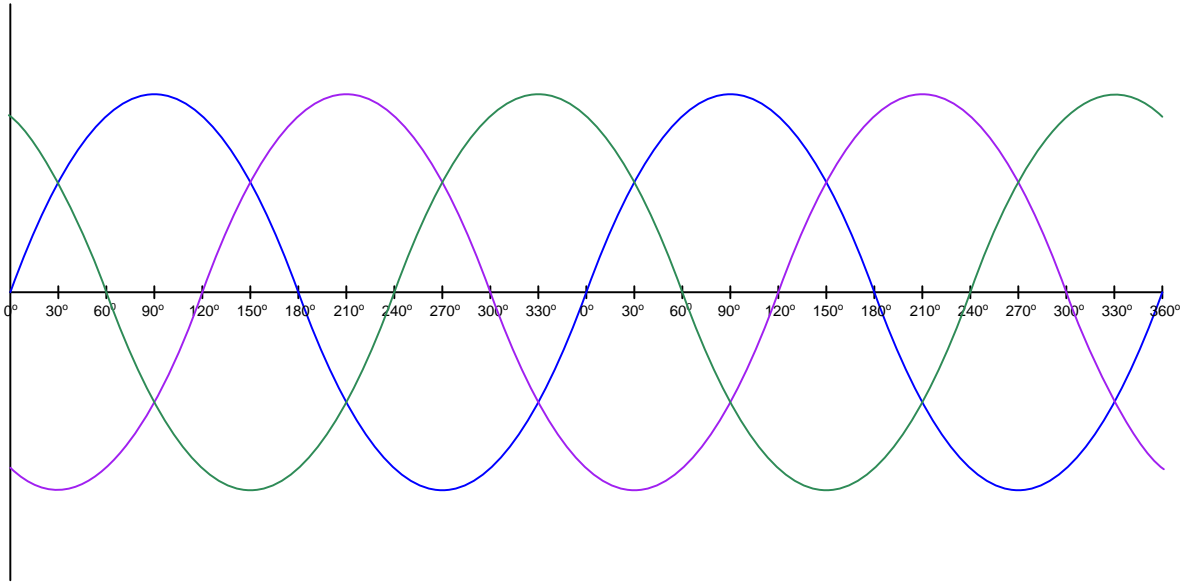

Answer 2

As the rotor spins clockwise, the lamps will blink from left to right (**C-B-A-C-B-A**). To reverse the sequence, simply swap any two wires ($A \leftrightarrow B$, $B \leftrightarrow C$, or $A \leftrightarrow C$). Swapping any two phases will change a C-B-A sequence into an A-B-C sequence.

Answer 3

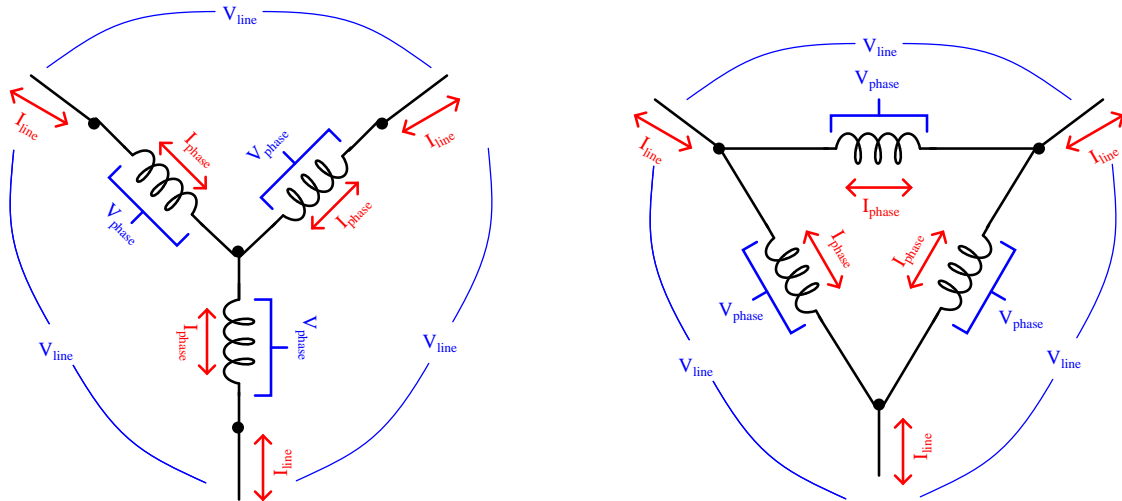

Wye configuration

- $I_{phase} = I_{line}$
- $V_{phase} < V_{line}$

Delta configuration

- $V_{phase} = V_{line}$
- $I_{phase} < I_{line}$

Answer 4

The current carried by each line will be absolutely equal to the current carried by its respective phase coil within the wye-connected source, for the simple reason that each line is in *series* with each phase element of a wye network, and series components share the same current (there being only one path between those components for current to flow). If either source or load are imbalanced, we would not expect any one line's current to equal any other line's current, but each line's current will be the same as the wye-coil it's connected to.

Similarly, we may conclude that voltage measured between any pair of parallel-connected points must be equal. In this circuit, an example of that would be the voltage measured between any two lines and the voltage of the phase coil between those same lines within the delta-connected motor.

When the upper phase coil within the motor fails open, it forces the remaining two phase coils to be in series with the upper two lines (one line per coil). This means each of the functional coils within the motor will share current equally with its respective line and respective phase coil within the wye-connected source. Voltage will be unaffected, still equal between sets of parallel-connected point-pairs.

Incidentally, the motor's new winding configuration is called *open-delta*, and it is a legitimate way to configure certain three-phase loads!

Answer 5

Any points lying in *series* with each other absolutely must share the same current, for the simple reason that the definition of series is having only one path for current to flow. Here is one example of multiple points (shown in red) sharing the exact same current:

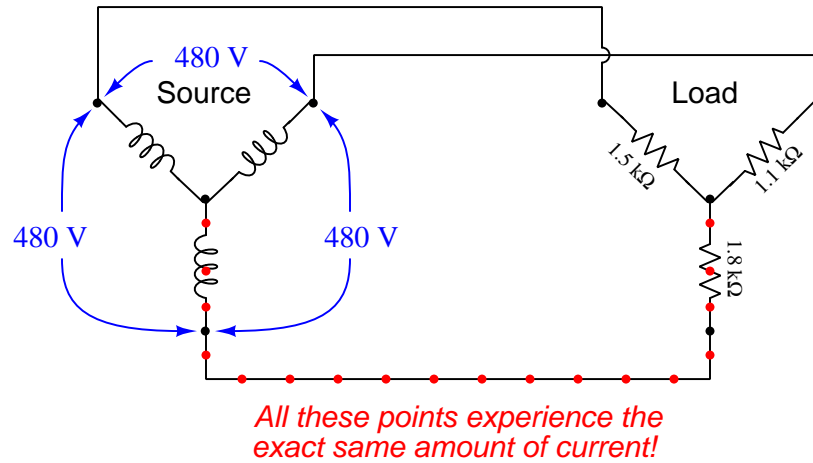

Any point-pairs in *parallel* with each other absolutely must share the same voltage between them, for the simple reason that the definition of parallel is sharing a pair of equipotential point sets. Here is one example of multiple point-pairs (shown in blue/red) sharing the exact same voltage:

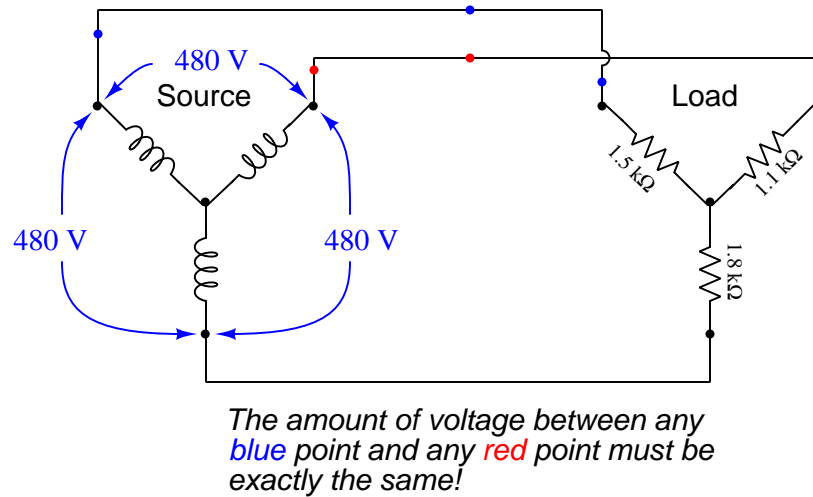

If we add a fourth “neutral” wire to this three-phase circuit, we force each of the load resistances to see the same amount of voltage: 277 volts from phase to neutral. Each line current will then be equal to 277 volts divided by that phase resistance. Phase voltages at the load will now be balanced, but line currents will still be imbalanced:

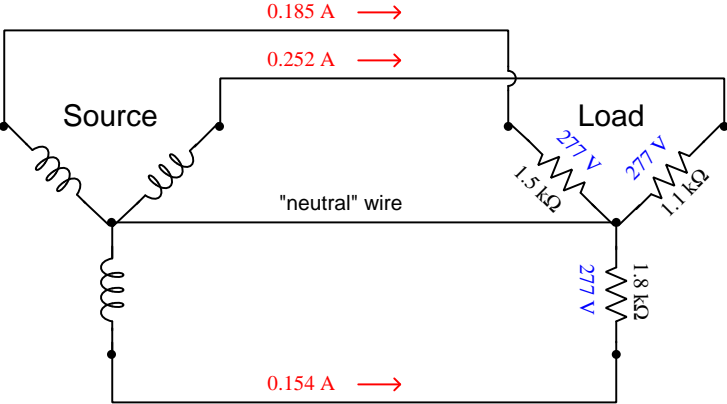

In case you are interested to know, the neutral wire’s current will be the *phasor sum* of these three line currents as they add together at the center node of the wye load where the neutral wire connects:

$$I_{neutral} = I_{phaseA} + I_{phaseB} + I_{phaseC}$$

$$I_{neutral} = 0.0867 \text{ A } \angle 137.9^\circ$$

Line current is easy to calculate, after converting 100 HP into 74600 watts:

$$P = \sqrt{3}I_{line}V_{line}$$

$$I_{line} = \frac{P}{\sqrt{3}V_{line}}$$

$$I_{line} = \frac{74600 \text{ W}}{\sqrt{3}(460 \text{ V})}$$

$$I_{line} = 93.63 \text{ A}$$

However, we need to know the amount of *phase* current in each of the motor's windings, and since the motor is wound in a delta fashion we know that line current is not equal to phase current (i.e. each line current "splits" into smaller phase currents at each of the nodes where lines join the delta network, in accordance with Kirchhoff's Current Law).

Being a balanced three-phase load, this "splitting" of current will follow the ratio of $\frac{1}{\sqrt{3}}$:

$$I_{phase} = \frac{I_{line}}{\sqrt{3}}$$

$$I_{phase} = \frac{93.63 \text{ A}}{\sqrt{3}}$$

$$I_{phase} = 54.06 \text{ A}$$

An alternative approach to solving for phase current would be to realize that in a balanced three-phase load, each of the three phases handles exactly one-third of the total power. There is no $\sqrt{3}$ factor in dividing power amongst the phase windings because energy is a scalar quantity and always adds directly, unlike voltage or current which are phasor quantities and must relate trigonometrically.

Since the total power in this case is 74600 watts, each of the three phase windings within the motor will convert one-third of that total electrical power (i.e. 24866.7 watts) into mechanical power. Since we can tell phase elements in a delta-connected network will experience line voltage (because each phase element is in parallel with a pair of power lines, and parallel-connected components always share the same voltage), we may treat each of the phase windings as a single-phase load. Calculating current for a single-phase load given power and voltage:

$$P = IV$$

$$I = \frac{P}{V}$$

$$I = \frac{24866.7 \text{ W}}{460 \text{ V}}$$

$$I = 54.06 \text{ A}$$

Answer 7

With switch W pressed, test point B will be equipotential with (i.e. “electrically common” to) earth ground. This ensures test point B will register 0 volts with respect to ground, because test point B *is* grounded. Test point D will now register one phase voltage (120 volts), while test points A and C will register line voltage (208 volts).

With switch Z pressed, test point D will now be grounded and register 0 volts. Test points A, B, and C will each register 120 volts to ground: their respective phase voltages.

Pressing both pushbuttons simultaneously is a *bad idea*, because it will directly short the phase B winding of the generator. This will cause excessive current to flow through that winding, most likely damaging it.

Answer 8

With switch W pressed, test point B will be equipotential with (i.e. “electrically common” to) earth ground. This ensures test point B will register 0 volts with respect to ground, because test point B *is* grounded. Test point D will now register one-half of the nominal phase voltage (i.e. $V_D = 60$ volts), while test points A and C will register line voltage which is the same as phase voltage for a delta-connected network (120 volts).

With switch Z pressed, test point A will now be grounded and register 0 volts. Test points B and C will each register 120 volts to ground: their respective phase (and line) voltages. Test point D will register 104 volts ($120 \text{ volts} \times \cos 30^\circ = \frac{120\sqrt{3}}{2}$).

Pressing both pushbuttons simultaneously is a *bad idea*, because it will directly short the left-hand phase winding of the generator. This will cause excessive current to flow through that winding, most likely damaging it.

Answer 9

- $V_{phase} \text{ (source)} = \underline{574.2 \text{ V}}$
- $I_{phase} \text{ (source)} = \underline{0.589 \text{ A}}$
- $V_{phase} \text{ (load)} = \underline{331.5 \text{ V}}$
- $I_{phase} \text{ (load)} = \underline{1.02 \text{ A}}$
- $V_{line} = \underline{574.2 \text{ V}}$
- $I_{line} = \underline{1.02 \text{ A}}$
- $P_{total} = \underline{1014.4 \text{ W}}$

Answer 10

- $V_{phase} \text{ (source)} = \underline{341.6 \text{ V}}$
- $I_{phase} \text{ (source)} = \underline{13.663 \text{ A}}$
- $V_{phase} \text{ (load)} = \underline{591.6 \text{ V}}$
- $I_{phase} \text{ (load)} = \underline{7.888 \text{ A}}$
- $V_{line} = \underline{591.6 \text{ V}}$
- $I_{line} = \underline{13.663 \text{ A}}$

Answer 11

Perhaps the simplest approach to this problem is to calculate the power dissipation of each resistor inside of each three-resistor array. Since power is a scalar quantity (i.e. it adds directly, not trigonometrically), the 15 kW total heat output of each array means each resistor inside of each array must dissipate 5 kW of power.

In the delta-connected heater, each resistor sees full line voltage (480 VAC), therefore the resistance may be calculated as such:

$$R = \frac{V^2}{P} = \frac{480^2}{5000} = 46.08 \Omega$$

In the wye-connected heater, each resistor sees $\frac{1}{\sqrt{3}}$ of the full line voltage (480 VAC), which is 277.1 VAC. Therefore the resistance may be calculated as such:

$$R = \frac{V^2}{P} = \frac{277.1^2}{5000} = 15.36 \Omega$$

Answer 12

$$P_{elec} = 198.146 \text{ kVA} = 265.61 \text{ HP}$$

$$P_{mech} = 244.36 \text{ HP}$$

Answer 13

The direct equivalence between horsepower and watts is 746 watts to 1 horsepower. Therefore, a 150 HP motor ideally consumes 111,900 watts (perfect efficiency). With an energy conversion efficiency of 93%, though, this input power figure will be larger than 111,900 watts to account for energy wasted in heat. Thus, our actual input power requirement for this 150 HP motor is 120,322.5 watts.

Applying the standard three-phase power formula, we may solve for line current assuming a perfect power factor:

$$P_{total} = \sqrt{3}(I_{line})(V_{line})$$

$$I_{line} = \frac{P_{total}}{\sqrt{3}(V_{line})}$$

$$I_{line} = \frac{120322.5}{\sqrt{3}(480)} = 144.73 \text{ amps}$$

Now, a power factor of less than 1 means some of the line current will *not* be performing useful work, but instead will be involved with the alternating exchange of energy stored and released by the load's inductance. With a power factor figure of 0.9, only 90% of the line current will be doing real work. We may deal with this percentage figure in much the same way as we dealt with efficiency: dividing the ideal line current by this figure will yield the actual line current for the motor:

$$I_{line} = 160.81 \text{ amps (at a power factor of 0.9)}$$

Answer 14

With 100:5 ratios at each CT, the line current to this motor is twenty times the amount of current through each ammeter:

$$(2.81) \left(\frac{100}{5} \right) = 56.2 \text{ amps}$$

At a line voltage of 480 VAC and a line current of 56.2 amps, the total electrical power in this 3-phase system may be calculated as follows:

$$P_{total} = (\sqrt{3})(I_{line})(V_{line})$$

$$P_{total} = (\sqrt{3})(56.2)(480) = 46.724 \text{ kW}$$

At an efficiency of 88%, only 88% of this power becomes translated into mechanical horsepower. This equates to 41.117 kW of mechanical power output at the motor shaft.

Since we know there are 746 watts to every horsepower, we may convert this kW figure into HP as follows:

$$\left(\frac{41117 \text{ W}}{1} \right) \left(\frac{1 \text{ HP}}{746 \text{ W}} \right) = 55.12 \text{ HP}$$

Answer 15

The transformer primary windings are connected in a Wye configuration, which means each primary winding receives the 7.2 kV phase voltage. The secondary windings are connected in a Delta configuration, making the secondary line voltage equal to 240 volts.

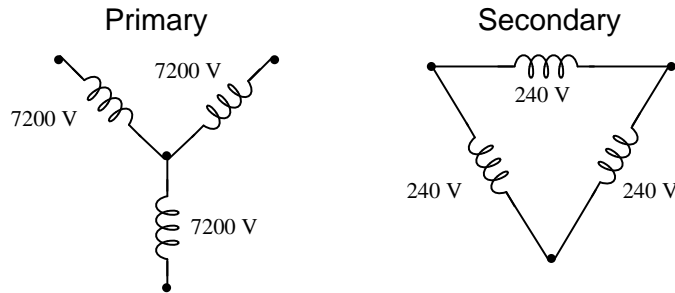

Answer 16

What we need here is a “wye” configuration on the secondary windings of the three transformers, using the center-tap of each to get 120 VAC at each phase. The pictorial diagram shown here is one possible solution, but not the only one:

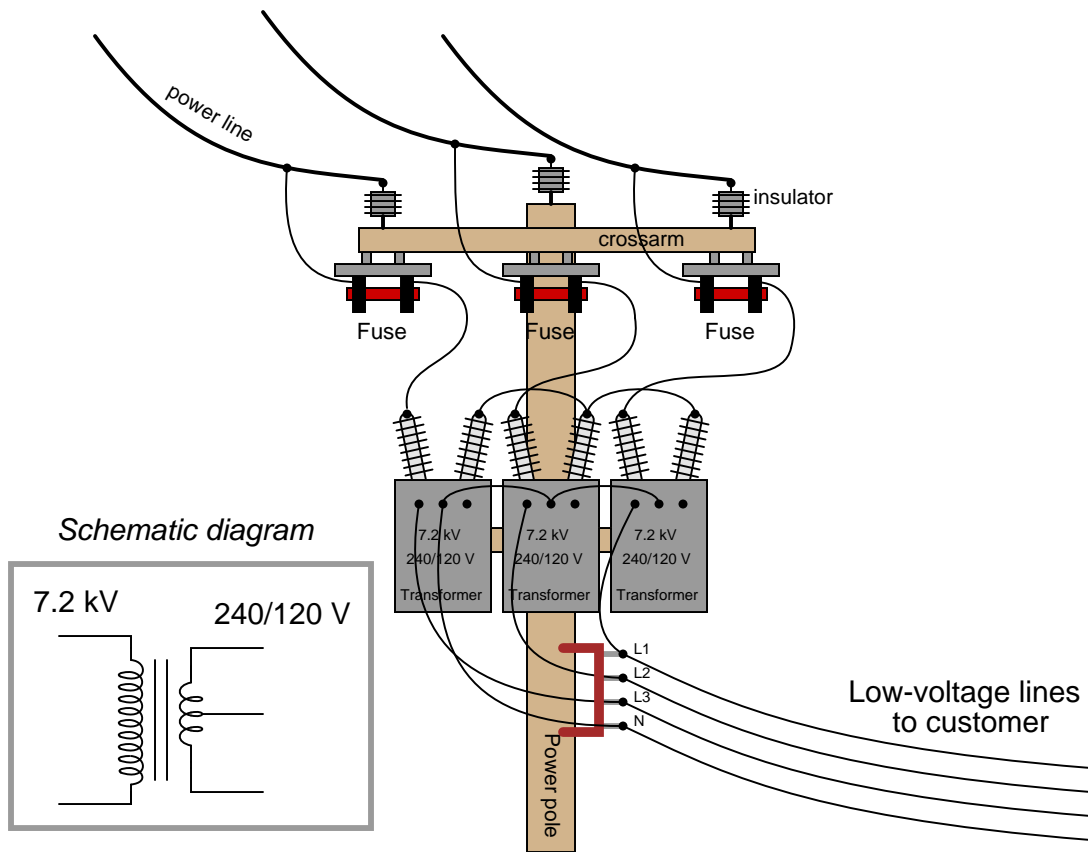

Answer 17

In the direct-connected load, each resistor sees $\frac{1}{\sqrt{3}}$ of the 13.8 kV line voltage (7967.4 volts), therefore, each resistor current is equal to:

$$I = \frac{V}{R} = \frac{7967.4}{1240} = 6.425 \text{ amps}$$

Since each resistor sees 7967.4 volts and carries 6.425 amps, the power for each resistor will be:

$$P = IV = (6.425)(7967.4) = 51.194 \text{ kW}$$

The power for this load is simply the power of all resistors combined:

$$P_{total} = 153.58 \text{ kW}$$

The three transformers have their primary windings connected in a Wye configuration, and their secondary windings in a Delta configuration. Thus, each transformer primary sees 7967.4 volts, stepping it down by a 16.67:1 ratio into 477.95 volts. The secondary windings, being Delta-connected, make this 477.95 volt value the line voltage for the load. The load is Delta-connected as well, and so each resistor in that load sees 477.95 volts, giving a resistor current of:

$$I = \frac{V}{R} = \frac{477.95}{950} = 0.5031 \text{ amps}$$

Since each resistor sees 477.95 volts and carries 0.5031 amp, the power for each resistor will be:

$$P = IV = (0.5031)(477.95) = 240.46 \text{ W}$$

The power for this load is simply the power of all resistors combined:

$$P_{total} = 721.38 \text{ W}$$

Answer 18

In a 4-wire system such as this, each phase of the load is guaranteed to see the proper (balanced) phase voltage of 120 VAC. Thus, calculating each line current is the same as calculating each phase (resistor) current as follows:

$$I_{L1} = \frac{120}{1500} = 0.08 \text{ amps}$$

$$I_{L2} = \frac{120}{2300} = 0.0522 \text{ amps}$$

$$I_{L3} = \frac{120}{800} = 0.15 \text{ amps}$$

Neutral conductor current will be the phasor sum of these three phase currents:

$$I_N = I_{L1} + I_{L2} + I_{L3}$$

Of course, we must remember that each of these three currents is phase-shifted from one another by 120 degrees. Arbitrarily choosing I_{L1} as our zero-degree phase reference, and assuming an L1-L3-L2 rotation:

$$I_N = 0.08 \text{ A } \angle 0^\circ + 0.0522 \text{ A } \angle 120^\circ + 0.15 \text{ A } \angle 240^\circ$$

$$I_N = 0.0873 \text{ A } \angle 256^\circ$$

Answer 19

The delta-connected motor will fare better, because it will still generate a polyphase (truly rotating) magnetic field, whereas the wye-connected motor will only generate an oscillating magnetic field. Also, the voltage across each phase winding of the delta-connected motor will remain the same as the line voltage, while the voltage across each phase winding of the wye-connected motor will decrease from what it was previous to the fault.

If the motors' mechanical loads are sufficiently light, both motors will continue to rotate. However, the delta-connected motor will have a greater torque capacity in this phase-loss condition than the wye-connected motor due to the fact that its rotating magnetic field still maintains a definite direction of rotation and also that each of its phase windings receives the same (full) voltage as previously.

If these consequences are not clear for you to see, you might wish to apply the problem-solving technique of *adding quantitative values* to the problem. Assign a line voltage (e.g. 480 VAC) to the incoming three-phase power conductors A, B, and C. Then, analyze the voltages at each phase winding of each motor before the fault versus after the fault. You may also calculate the *phase angle* for each of these winding voltages to see that the delta-connected motor still has three 120°-shifted voltages powering it, while the wye-connected motor only has one voltage (single phase) powering it.

Answer 20

$$P = 202.3 \text{ hp}$$

If you calculated 181.5 amps for line current, you're close – you have assumed 100% efficiency for the motor! The actual line current is 197.2 amps if you take the motor's 92% efficiency into account.

Here is a formula you can use to convert torque (lb-ft) and speed (RPM) values into horsepower:

$$P = \frac{S\tau}{5252.113}$$

I don't expect anyone to memorize a formula like this, but one may derive it from a "thought experiment." It should be intuitively obvious that power (P) must be directly proportional to both torque (τ) and speed (S), with some constant of proportionality (k) included to account for units:

$$P \propto S\tau$$

$$P = kS\tau$$

If we were to imagine a 1-foot radius drum hoisting a 550 pound rate vertically at 1 foot per second as an example of a machine exerting exactly 1 horsepower, we may solve for τ and S , then calculate the necessary constant to make P equal to 1. The drum's torque would be 550 lb-ft, of course (550 lb of force exerted over a moment arm of 1 foot). With a circumferential speed of 1 foot per second, it would rotate at $\frac{1}{2\pi}$ revolutions per second, or $\frac{30}{\pi}$ RPM. If $\tau = 550$ and $S = \frac{30}{\pi}$ and $P = 1$ horsepower, then:

$$P = \frac{\pi S\tau}{30 \times 550}$$

In answer to the Socratic discussion question, the 92% efficiency works to diminish output current, rather than increase input current as in the case of the motor. Thus, the diesel-powered generator will output a line current of 167 amps.