

Applications of trigonometry

This worksheet and all related files are licensed under the Creative Commons Attribution License, version 1.0. To view a copy of this license, visit <http://creativecommons.org/licenses/by/1.0/>, or send a letter to Creative Commons, 559 Nathan Abbott Way, Stanford, California 94305, USA. The terms and conditions of this license allow for free copying, distribution, and/or modification of all licensed works by the general public.

Table of Sine, Cosine and Tangent functions

ANGLE	Sine	Cosine	Tangent	ANGLE	Sine	Cosine	Tangent
0	0.000	1.000	0.000	45	0.707	0.707	1.000
1	0.017	1.000	0.017	46	0.719	0.695	1.036
2	0.035	0.999	0.035	47	0.731	0.682	1.072
3	0.052	0.999	0.052	48	0.743	0.669	1.111
4	0.070	0.998	0.070	49	0.755	0.656	1.150
5	0.087	0.996	0.087	50	0.766	0.643	1.192
6	0.105	0.995	0.105	51	0.777	0.629	1.235
7	0.122	0.993	0.123	52	0.788	0.616	1.280
8	0.139	0.990	0.141	53	0.799	0.602	1.327
9	0.156	0.988	0.158	54	0.809	0.588	1.376
10	0.174	0.985	0.176	55	0.819	0.574	1.428
11	0.191	0.982	0.194	56	0.829	0.559	1.483
12	0.208	0.978	0.213	57	0.839	0.545	1.540
13	0.225	0.974	0.231	58	0.848	0.530	1.600
14	0.242	0.970	0.249	59	0.857	0.515	1.664
15	0.259	0.966	0.268	60	0.866	0.500	1.732
16	0.276	0.961	0.287	61	0.875	0.485	1.804
17	0.292	0.956	0.306	62	0.883	0.469	1.881
18	0.309	0.951	0.325	63	0.891	0.454	1.963
19	0.326	0.946	0.344	64	0.899	0.438	2.050
20	0.342	0.940	0.364	65	0.906	0.423	2.145
21	0.358	0.934	0.384	66	0.914	0.407	2.246
22	0.375	0.927	0.404	67	0.921	0.391	2.356
23	0.391	0.921	0.424	68	0.927	0.375	2.475
24	0.407	0.914	0.445	69	0.934	0.358	2.605
25	0.423	0.906	0.466	70	0.940	0.342	2.747
26	0.438	0.899	0.488	71	0.946	0.326	2.904
27	0.454	0.891	0.510	72	0.951	0.309	3.078
28	0.469	0.883	0.532	73	0.956	0.292	3.271
29	0.485	0.875	0.554	74	0.961	0.276	3.487
30	0.500	0.866	0.577	75	0.966	0.259	3.732
31	0.515	0.857	0.601	76	0.970	0.242	4.011
32	0.530	0.848	0.625	77	0.974	0.225	4.331
33	0.545	0.839	0.649	78	0.978	0.208	4.705
34	0.559	0.829	0.675	79	0.982	0.191	5.145
35	0.574	0.819	0.700	80	0.985	0.174	5.671
36	0.588	0.809	0.727	81	0.988	0.156	6.314
37	0.602	0.799	0.754	82	0.990	0.139	7.115
38	0.616	0.788	0.781	83	0.993	0.122	8.144
39	0.629	0.777	0.810	84	0.995	0.105	9.514
40	0.643	0.766	0.839	85	0.996	0.087	11.430
41	0.656	0.755	0.869	86	0.998	0.070	14.301
42	0.669	0.743	0.900	87	0.999	0.052	19.081
43	0.682	0.731	0.933	88	0.999	0.035	28.636
44	0.695	0.719	0.966	89	1.000	0.017	57.290
				90	1.000	0.000	∞

Questions

Question 1

The *Pythagorean Theorem* is a mathematical relationship between the lengths of the sides of a right triangle. Sometimes this relationship is represented graphically:

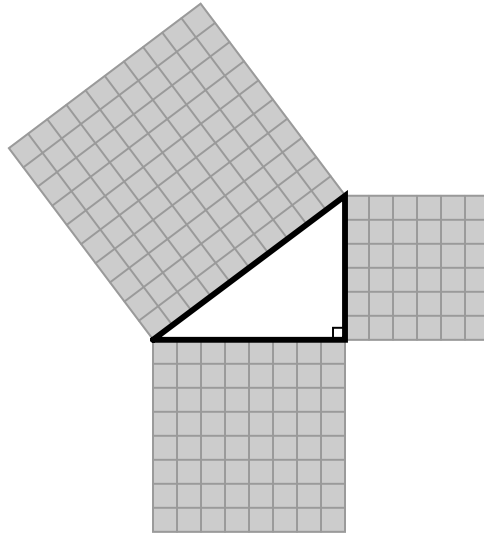

Explain how this geometrical illustration relates to the Pythagorean Theorem ($c^2 = a^2 + b^2$).
[file i02676](#)

Question 2

Geometry may be used to elegantly prove the Pythagorean Theorem. Shown here are two squares of equal area, each with four right triangles embedded within, occupying area of their own:

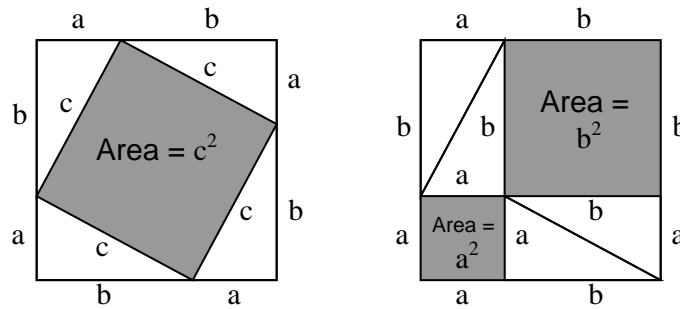

Explain how these two figures prove the Pythagorean Theorem, where $a^2 + b^2 = c^2$.
[file i02677](#)

Question 3

Use the *Pythagorean Theorem* to determine the unknown lengths of the following (right) triangles:

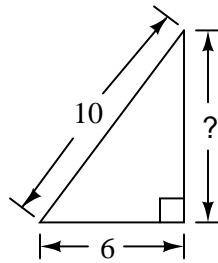
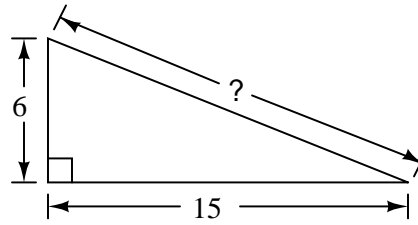
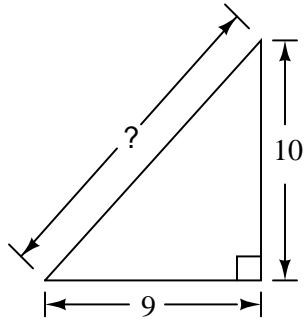

[file i02066](#)

Question 4

Examine this right triangle (a triangle with one 90° angle), and identify which side is the opposite, the adjacent, and the hypotenuse as viewed from two different angles (a and b):

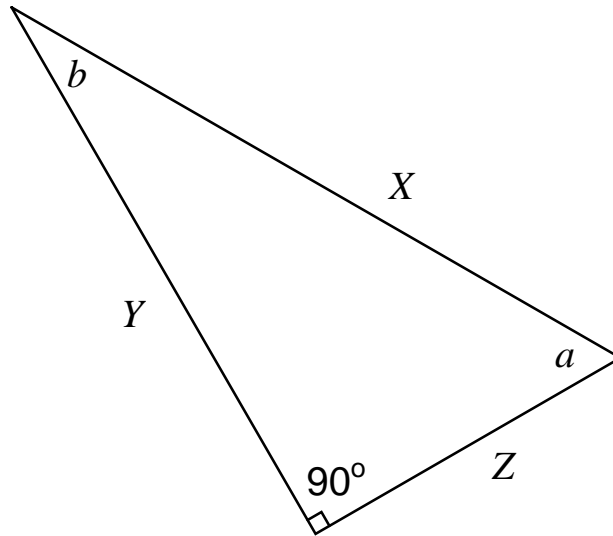

As viewed from angle a :

- Opposite side = _____
- Adjacent side = _____
- Hypotenuse side = _____

As viewed from angle b :

- Opposite side = _____
- Adjacent side = _____
- Hypotenuse side = _____

[file i02648](#)

Question 5

Use trigonometric functions (sine, cosine, tangent) to determine all unknown lengths and angles in these right triangles:

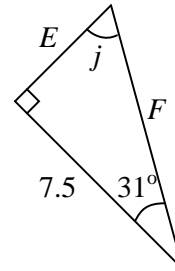
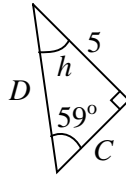
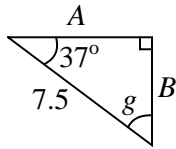
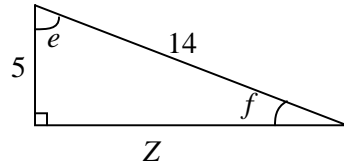
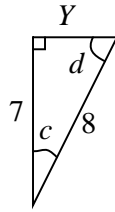
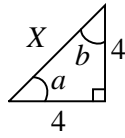

[file i02067](#)

Question 6

Calculate the angles θ and Φ in this right triangle:

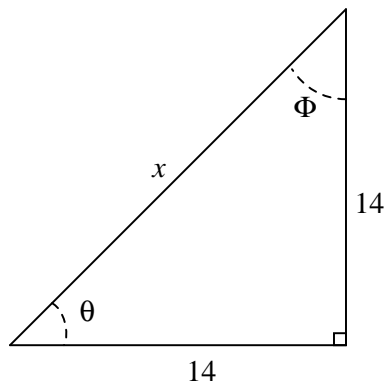

[file i02675](#)

Question 7

Suppose you were laying out the forms for a house foundation, and had to ensure the corners were “square” (exactly 90°):

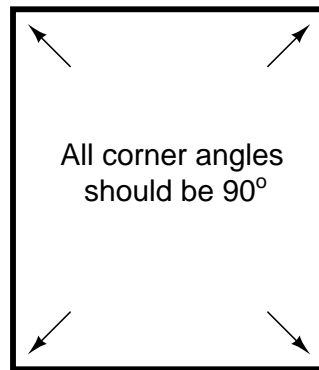

How could you ensure this, using trigonometry? How would you ensure this if you had no calculator with you to calculate trig functions, and no protractor or framing square with you to measure angles?

Hint: remember that the lengths 3-4-5 happen to form a right triangle!

[file i02678](#)

Question 8

A model rocket enthusiast wants to approximately measure the peak altitude of her rocket by measuring the angle from horizontal (θ) sighting the rocket at its apogee and the distance from the launch pad to the point of observation. Which trigonometric function will she need to use in order to calculate the rocket's height?

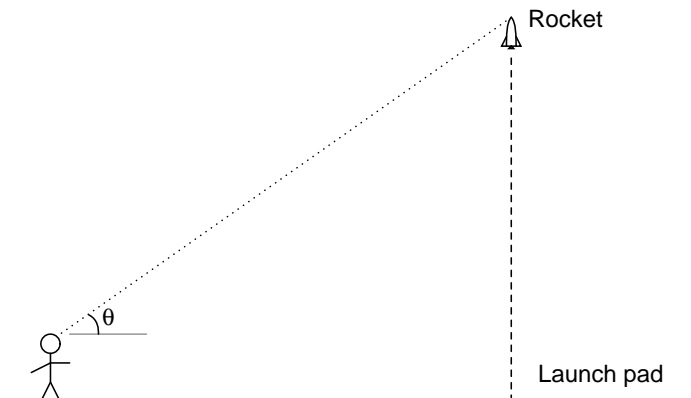

- (A) Tangent
- (B) Cosine
- (C) Cosecant
- (D) Sine
- (E) Secant

[file i02680](#)

Question 9

We may analyze the horizontal and vertical “components” of an angled force by sketching a right triangle and calculating the lengths of that triangle’s sides. The angled force vector length will be the magnitude of the applied force, while the opposite and adjacent side lengths will represent the horizontal and vertical components of that force.

In this example, we see a person pushing a lawnmower. The handle of this lawnmower transmits a force of 20 pounds from the person’s body to the lawnmower frame, at an angle of 32 degrees from horizontal:

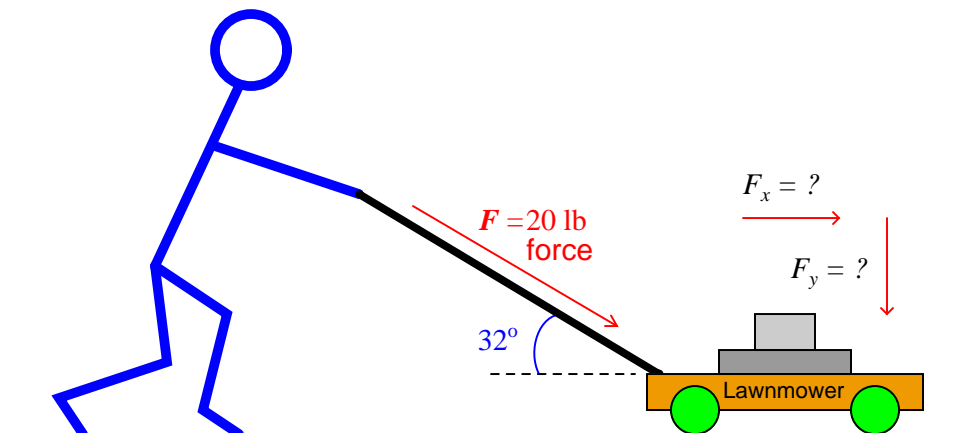

Use trigonometry to calculate how much of this angled force translates into *forward* (horizontal) force to drive the lawnmower forward against the friction of the grass, and how much of the applied force translates to *downward* (vertical) force pressing the lawnmower wheels against the ground.

$$F_{forward} = F_x = \underline{\hspace{2cm}} \text{ lbs}$$

$$F_{down} = F_y = \underline{\hspace{2cm}} \text{ lbs}$$

If the person doing the lawnmowing wishes to apply their force more efficiently to the mower (i.e. more of their force going into the forward component and less pushing downward), should they hold the lawnmower handle at a shallower angle or at a steeper angle?

Suggestions for Socratic discussion

- A technique highly recommended for word-problems is to *sketch a picture* of the problem and label elements of that picture with the given information. Do this, and compare your sketch with those of your classmates. How, specifically, does this aid your problem-solving?

[file i02068](#)

Question 10

A truck with a winch on the front is pulling a car up a steep hill. The tension (pulling force) in the cable is 1000 pounds. How many pounds is the horizontal component of this force that the truck has to resist with its brakes? How many pounds is the vertical component of this force that the truck has to resist with its suspension (springs)? Assume that the angle of the hill is 35° from level:

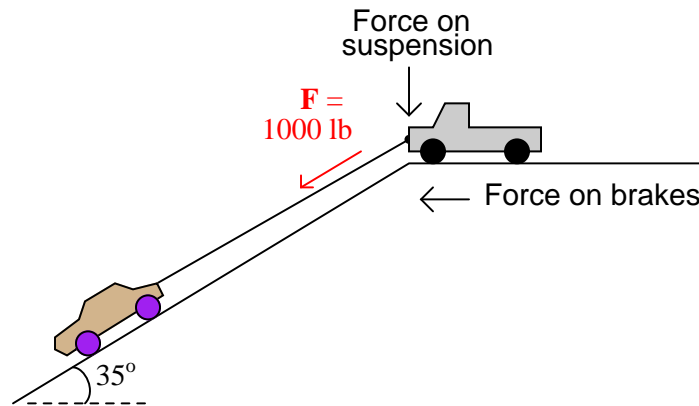

$$F_{brakes} = \text{_____} \text{ lbs}$$

$$F_{suspension} = \text{_____} \text{ lbs}$$

Suggestions for Socratic discussion

- A technique highly recommended for word-problems is to *sketch a picture* of the problem and label elements of that picture with the given information. Do this, and compare your sketch with those of your classmates. How, specifically, does this aid your problem-solving?

[file i02069](#)

Question 11

In the act of turning a wind turbine's rotor, wind also exerts a horizontal force on the supporting tower. To stabilize the wind turbine tower, "guy" wires are attached near the top of the tower to anchor points on the ground:

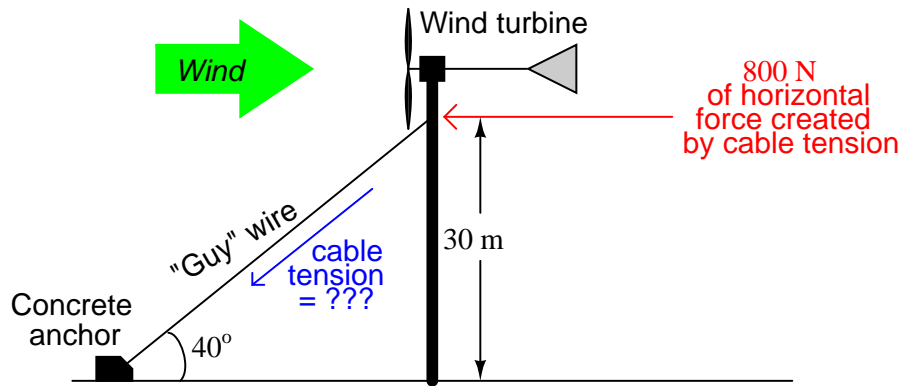

Suppose that a wind is exerting 800 Newtons of horizontal force on the tower, measured at the point of connection between the guy wire and the tower. This connection point is 30 meters from ground level, and the angle of the guy wire to the ground is 40°. Assuming that the single guy wire is bearing the full load of this wind force, how many Newtons of tension will this guy wire experience?

$$F_{tension} = \text{_____} \text{ lbs}$$

Supposing we are interested in minimizing the amount of tension the guy wire must bear, should we re-locate the concrete anchor closer to the base of the wind turbine tower or farther away from the base of the wind turbine tower?

[file i02585](#)

Question 12

A house has a 3:12 roof slope. Supposing that one of the triangular truss structures in the roof bears 500 pounds of snow load (equivalent to 500 pounds of force applied to the peak of the triangle), how much tensile (pulling) force will there be in the horizontal beam?

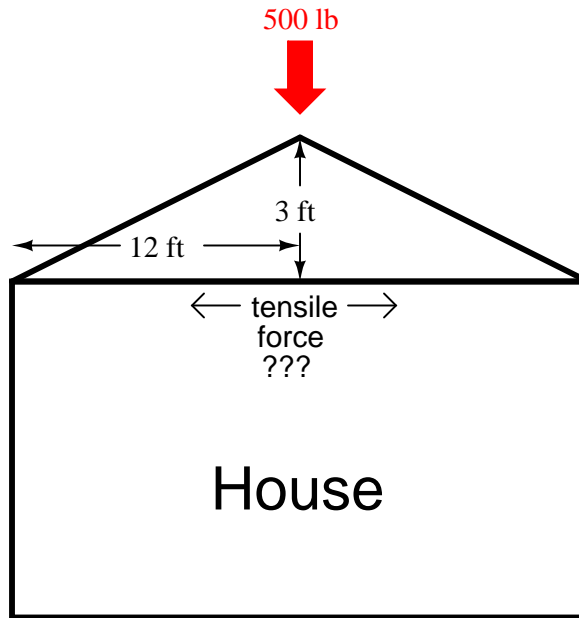

$$F_{beam} = \text{_____} \text{ lbs}$$

[file i02577](#)

Question 13

A 150 pound weight is suspended by a hinged strut, which is kept at an angle of 45° by the tension in a cable. Determine the compressive force within the strut as well as the tension within the cable. Assume that the cable is perfectly horizontal and that the strut is weightless:

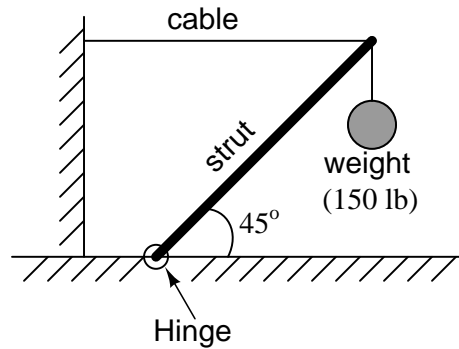

$$F_{strut} = \text{_____} \text{ lbs}$$

$$F_{cable} = \text{_____} \text{ lbs}$$

What will happen to the forces on the strut and on the cable as the strut is angled closer to vertical?

[file i02578](#)

Question 14

A 200 newton weight is suspended by a hinged strut, which is kept at an angle of 30° by the tension in a cable. Determine the compressive force within the strut as well as the tension within the cable. Assume that the cable is perfectly horizontal and that the strut is weightless:

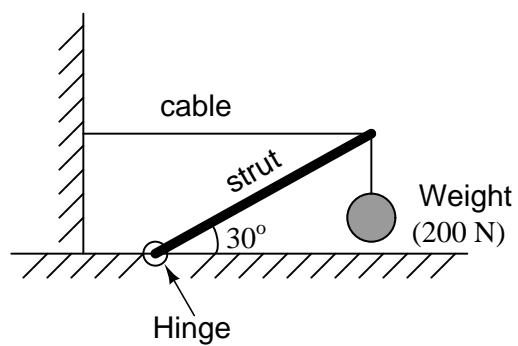

$$F_{strut} = \text{_____} \text{ N}$$

$$F_{cable} = \text{_____} \text{ N}$$

file i02647

Question 15

If the rear wheel of this bicycle supports 70% of the rider's weight, determine the compressive force within the *seat stays* (the struts leading from the seat of the bicycle to the center of the rear wheel, as opposed to the *chain stays* connecting the crank bracket to the wheel center) if the rider weighs 190 pounds. Give your answer in the form of a total amount of compressive force for the two seat stays (there are two of them, one on each side of the rear wheel). Assume that the chain stays are level with the ground:

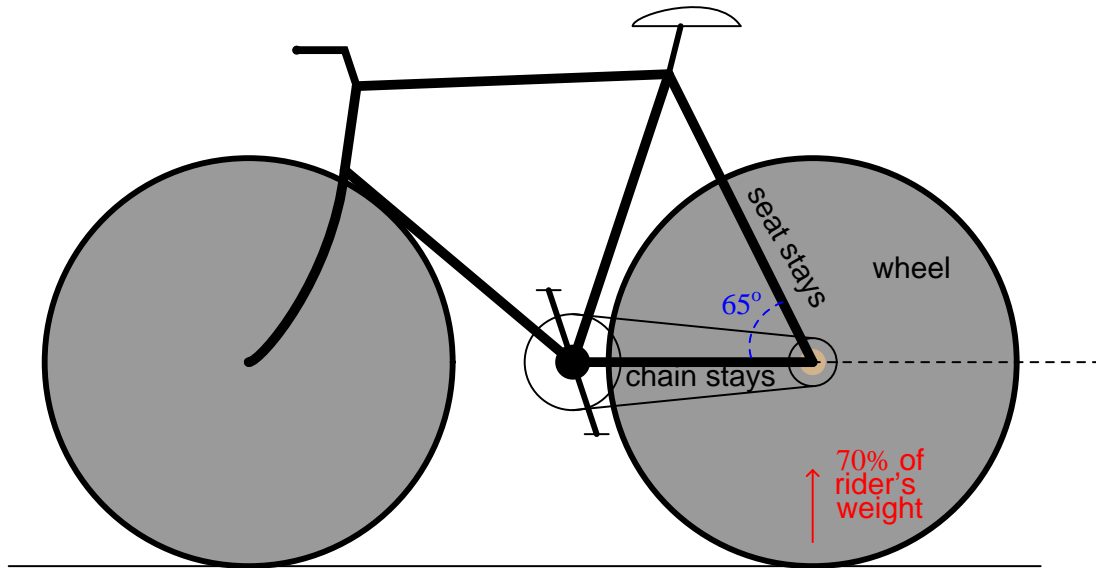

$F_{seatstay} = \underline{\hspace{2cm}}$ lbs

file i02579

Question 16

A 15 pound weight hangs from the ceiling, suspended from two equal-length strings. The angle of each string is 50° from horizontal:

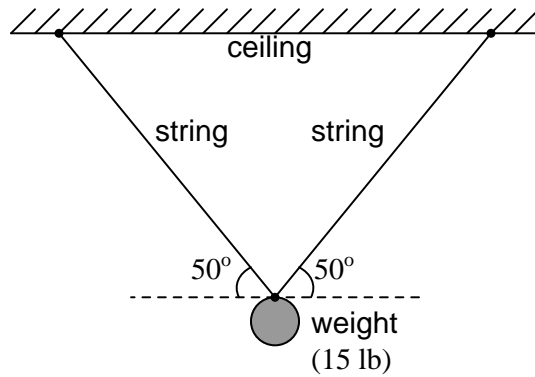

Calculate the amount of tension in each string. Hint: because the strings are equal length and have equal angles with respect to horizontal, the tension in each string will likewise be equal.

$$F_{tension} = \text{_____ lbs}$$

Suggestions for Socratic discussion

- Perform a “thought experiment” where you imagine the angles in this problem approaching 90° (i.e. vertical strings). What happens to the tension within each string as they become more vertical?

[file i02586](#)

Question 17

A 50 pound weight hangs by two strings, string **A** pulling at an angle and string **B** pulling horizontally. The angle of string A is 60° from level (i.e. 30° from vertical). Calculate the tension within each string:

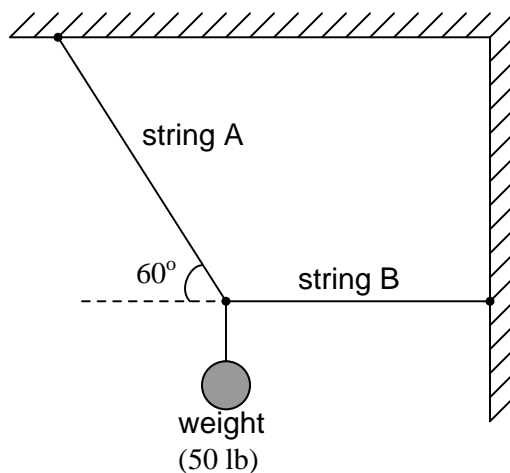

$$F_{tension_A} = \text{_____} \text{ lbs}$$

$$F_{tension_B} = \text{_____} \text{ lbs}$$

file i02587

Question 18

A process called *delayed coking* is used in the oil refining industry to convert heavy oils and tars into higher-valued petroleum products. A process vessel called a *coke drum* has a removable lid held down by a series of bolts, and alternatively by a hydraulic ram. When it comes time to open up the coke drum, the hydraulic ram is pressurized to maintain adequate force on the coke drum lid, the bolts are removed, and then the ram's fluid pressure is reduced until the lid springs open from the force of the gas pressure inside the coke drum:

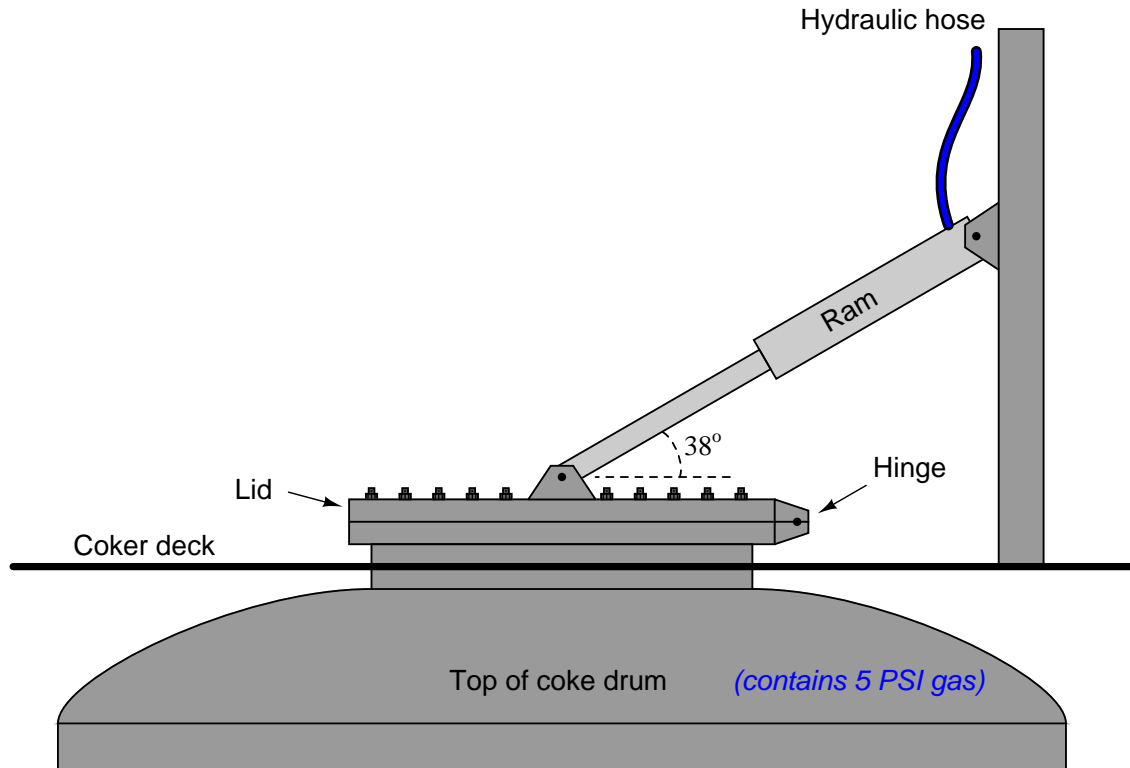

Calculate the hydraulic pressure necessary to hold down the lid on the coke drum when the gas pressure inside the drum is 5 PSI and all hold-down bolts have been removed from the lid. Assume a lid diameter of 30 inches, and a ram piston diameter of 4 inches. Hint: sketch a right triangle, representing forces as side lengths on the triangle – the ram's diagonal force will translate into both a horizontal force on the lid (which you may ignore) and a vertical force on the lid (which is what we're interested in here).

Hydraulic $P =$ _____ PSI

Suggestions for Socratic discussion

- Which direction will the horizontal force component be exerted on the lid?
- Identify the potential hazards of a hydraulic oil leak in this system. Compare the effects of a slow leak (e.g. a leaky fitting connecting the hose to the ram) versus a catastrophic leak (e.g. the hose bursting from excess pressure).

[file i04683](#)

Answers

Answer 1

This illustration represents the Pythagorean Theorem in geometric form: the *squares* of the lengths of the opposite and adjacent sides, when added, equal the *square* of the length of the hypotenuse.

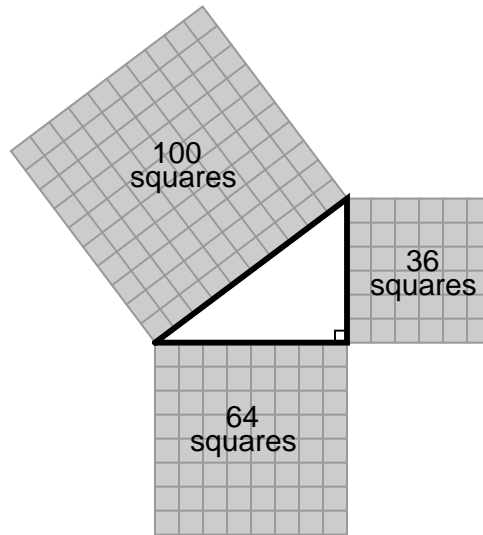

The side lengths of this triangle are 6, 8, and 10. Their corresponding areas are 36, 64, and 100.

Answer 2

In both squares, the total area is equal because the squares have identical dimensions. In both squares, the area occupied by the four triangles is also equal, because the triangles all share the same dimensions. Therefore, the total shaded area in each square must also be equal.

As you can see, the left square's shaded area is equal to c^2 , while the right square's shaded area is equal to the sum of $a^2 + b^2$, thereby proving the Pythagorean Theorem.

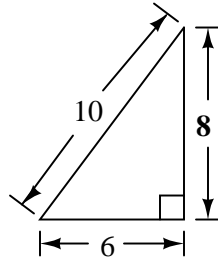
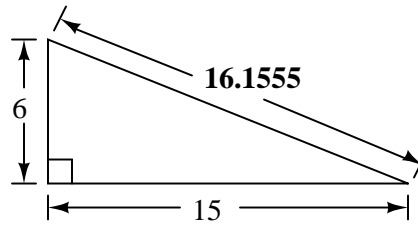
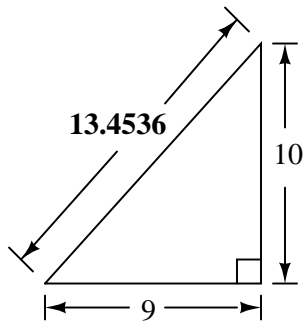

Answer 4

As viewed from angle a :

- Opposite side = \underline{Y}
- Adjacent side = \underline{Z}
- Hypotenuse side = \underline{X}

As viewed from angle b :

- Opposite side = \underline{Z}
- Adjacent side = \underline{Y}
- Hypotenuse side = \underline{X}

Imagine the triangle being a room, viewed from above, with you standing at the location of the angle in question. The hypotenuse is *always* the longest of the three sides in a right triangle, regardless of which angle is being considered. The *adjacent* side is the non-hypotenuse side that you can reach from where you stand (i.e. the side that is “adjacent to” or “next to” the angle). The *opposite* side is the non-hypotenuse side that you can see on the other side of the room from your location (i.e. the side that is “opposite” the angle).

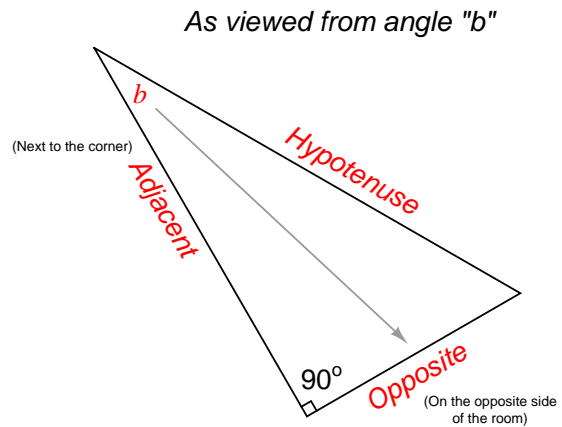
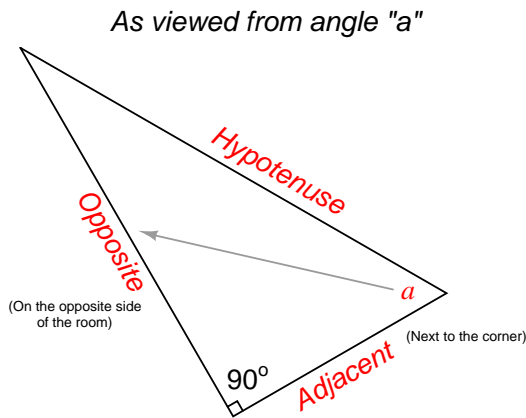

Answer 5

$$\begin{aligned} a &= 45^\circ \\ b &= 45^\circ \\ X &= 5.657 \end{aligned}$$

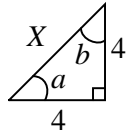

$$\begin{aligned} c &= 28.955^\circ \\ d &= 61.045^\circ \\ Y &= 3.873 \end{aligned}$$

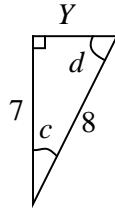

$$\begin{aligned} e &= 69.075^\circ \\ f &= 20.925^\circ \\ Z &= 13.077 \end{aligned}$$

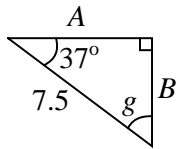
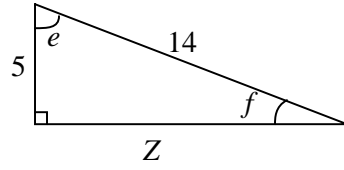

$$\begin{aligned} g &= 53^\circ \\ A &= 5.990 \\ B &= 4.514 \end{aligned}$$

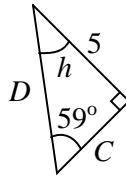

$$\begin{aligned} h &= 31^\circ \\ C &= 3.004 \\ D &= 5.833 \end{aligned}$$

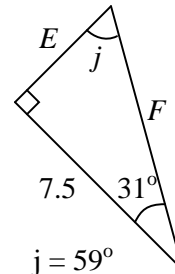

$$\begin{aligned} j &= 59^\circ \\ E &= 4.506 \\ F &= 8.750 \end{aligned}$$

Answer 6

$$\theta = \Phi = 45^\circ$$

Answer 7

Using two adjacent sides of the foundation form, measure the diagonal and calculate whether its length is equal to the length of the hypotenuse for a right triangle.

To do this with no calculator and with no angle-measuring tools, you could mark lengths along the two sides of the form equal to multiples of 3 and 4, then measure a diagonal length between those end points to see if it was equal to the same multiple of 5:

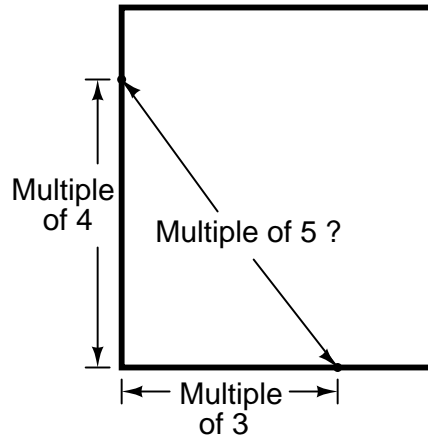

Answer 8

The “tangent” function is the proper one to use, since the rocket’s height is the side *opposite* the angle and the distance between the enthusiast and the launch pad is the side *adjacent* to the angle.

$$\tan \theta = \frac{\text{Opposite side length}}{\text{Adjacent side length}}$$

In this particular example, the rocket’s height (h) may be calculated from the angle (θ), the launch-pad distance (d) and the person’s height (x) as such:

$$h = x + d \tan \theta$$

Answer 9

$$F_{\text{forward}} = F_x = (20 \text{ lb}) (\cos 32^\circ) = \mathbf{16.96 \text{ lbs}}$$

$$F_{\text{down}} = F_y = (20 \text{ lb}) (\sin 32^\circ) = \mathbf{10.60 \text{ lbs}}$$

Maximum pushing efficiency will be realized when the person shrinks to the height of the lawnmower deck and is pushing 100% horizontally (0° angle from the ground).

Answer 10

The truck’s brakes must resist **819.15** pounds of horizontal force, to keep it from rolling in the direction of the slope. The truck’s suspension must bear **573.58** pounds of vertical force (in addition to the truck’s own front-end weight).

Answer 11

$$F_{tension} = 1044.3 \text{ N}$$

The concrete guy wire anchor should be relocated farther away from the tower in order to minimize wire tension. A farther distance will decrease the angle to ground. As this angle approaches zero degrees (level with the ground), the guy wire tension will approach the minimum value of 800 Newtons.

Answer 12

It might be easier to approach this problem if we consider one-half of the truss at a time. The 500 pounds snow load will be evenly borne by each side of the truss, such that the tension in each half of the horizontal beam handles half of the force necessary to create the 500 pounds of upward force resisting the snow.

Our pitch ratio of 3:12 (or 1:4) tells us the horizontal beam tension will be four times the snow load. If each half of the truss bears 250 pounds of snow, then each half of the horizontal beam will experience 1000 pounds of tension. The two beam halves' tensions translate into 250 pounds of vertical force (each), making 500 pounds of vertical force. The 1000 pounds of tension in each half of the beam do *not* add up to 2000 pounds because the tension in each beam half is pointed in opposite directions in order for the horizontal forces to cancel (otherwise, the truss would be accelerating horizontally!):

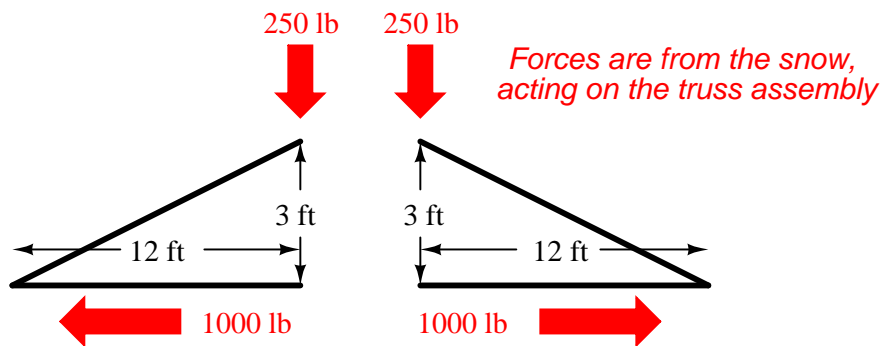

Answer 13

$$F_{strut} = 212.1 \text{ lbs}$$

$$F_{cable} = 150 \text{ lbs}$$

As the strut angle becomes more vertical, the strut experiences **less** compressive force and the cable also experiences **less** tension.

Answer 14

$$F_{strut} = 400 \text{ N}$$

$$F_{cable} = 346.4 \text{ N}$$

Answer 15

Combined seat stay compression = **146.749 lbs**. Ideally, this will equate to **73.37** pounds of compressive force in each of the two seat stays.

Answer 16

$$F_{tension} = 9.791 \text{ lbs (in each string)}$$

In this system of forces, string **A** exerts both a vertical and a horizontal force at the junction point of the three strings, just above the weight. String **B** only exerts a horizontal force at that point:

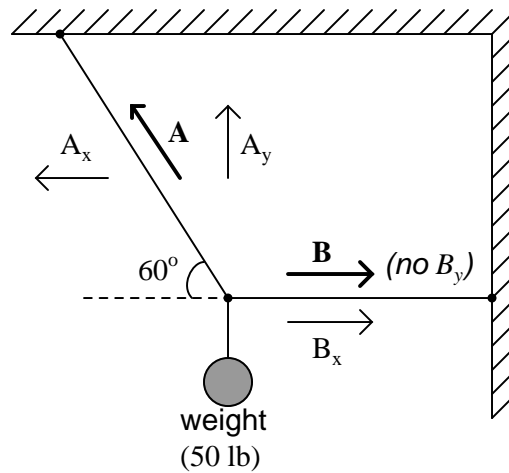

Because string **A** is the only one with a vertical force component, it must be doing all the work in suspending the 50 pound weight. String **B** merely pulls laterally, and does not contribute to the effort of suspending the weight. Therefore, if since we know A_y is the only force component working to oppose the 50 pound vertical force of the weight, we can solve for **A** using trigonometry:

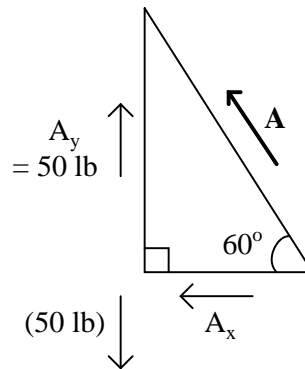

We have a right triangle with an opposite side length of 50 and an angle of 60° . To solve for the length of the hypotenuse:

$$F_{tension_A} = (50 \text{ lb}) / (\sin 60^\circ) = \mathbf{57.735 \text{ lbs}}$$

So, string **A** must have a tension of 57.735 pounds. That this figure is greater than 50 makes sense, because the angle of string **A** with respect to vertical makes it less efficient at opposing the force of the weight. If the string were perfectly vertical, its tension would only have to be 50 pounds to suspend the weight, but since it is not perfectly vertical its tension must be more than that.

Being angled, string **A** also exerts a horizontal force. Since nothing in this system is moving, it must be in a condition of translational equilibrium, so the horizontal component of tension **A** (known as A_x) must be opposed by another force. This other force is the tension of string **B**. We may calculate A_x (and, consequently, **B** as well), by using trigonometry again:

$$F_{tension_B} = A_x = (57.735 \text{ lb})(\cos 60^\circ) = \mathbf{28.868 \text{ lbs}}$$

Answer 18

With a piston diameter of 4 inches, a hydraulic pressure of 456.83 PSI is necessary to generate 5740.6 pounds. This is a *minimum* pressure, for safety reasons. More than 456.83 PSI won't do any harm, but less than this amount will fail to hold down the lid!